

SECTION **IP**

INSTRUMENT PANEL

A
B
C
D
E
F
G
H
IP
J
K
L
M

CONTENTS

<p>PRECAUTIONS 2</p> <p style="padding-left: 20px;">Precautions for Supplemental Restraint System (SRS) “AIR BAG” and “SEAT BELT PRE-TENSIONER” 2</p> <p style="padding-left: 20px;">Precautions for Battery Service 2</p> <p style="padding-left: 20px;">Precautions 2</p> <p>PREPARATION 3</p> <p style="padding-left: 20px;">Special Service Tools 3</p> <p style="padding-left: 20px;">Commercial Service Tools 3</p> <p>SQUEAK AND RATTLE TROUBLE DIAGNOSES..... 4</p> <p style="padding-left: 20px;">Work Flow 4</p> <p style="padding-left: 40px;">CUSTOMER INTERVIEW 4</p> <p style="padding-left: 40px;">DUPLICATE THE NOISE AND TEST DRIVE 5</p> <p style="padding-left: 40px;">CHECK RELATED SERVICE BULLETINS 5</p> <p style="padding-left: 40px;">LOCATE THE NOISE AND IDENTIFY THE ROOT CAUSE 5</p> <p style="padding-left: 40px;">REPAIR THE CAUSE 5</p> <p style="padding-left: 40px;">CONFIRM THE REPAIR 6</p> <p style="padding-left: 20px;">Generic Squeak and Rattle Troubleshooting 6</p> <p style="padding-left: 40px;">INSTRUMENT PANEL 6</p>	<p style="padding-left: 20px;">CENTER CONSOLE 6</p> <p style="padding-left: 20px;">DOORS 6</p> <p style="padding-left: 20px;">TRUNK 7</p> <p style="padding-left: 20px;">SUNROOF/HEADLINING 7</p> <p style="padding-left: 20px;">SEATS 7</p> <p style="padding-left: 20px;">UNDERHOOD 7</p> <p style="padding-left: 20px;">Diagnostic Worksheet 8</p> <p>INSTRUMENT PANEL ASSEMBLY 10</p> <p style="padding-left: 20px;">Component Parts Drawing 10</p> <p style="padding-left: 20px;">Removal and Installation 11</p> <p style="padding-left: 40px;">WORK STEP 11</p> <p style="padding-left: 40px;">REMOVAL 12</p> <p style="padding-left: 40px;">INSTALLATION 15</p> <p style="padding-left: 20px;">Disassembly and Assembly 17</p> <p style="padding-left: 40px;">CLUSTER LID A 17</p> <p style="padding-left: 40px;">CLUSTER LID C 18</p> <p style="padding-left: 40px;">CENTER BOX ASSEMBLY 19</p> <p style="padding-left: 40px;">CENTER CONSOLE (A/T MODELS) 20</p> <p style="padding-left: 40px;">CENTER CONSOLE (M/T MODELS) 21</p>
---	---

PRECAUTIONS

PRECAUTIONS

PFP:00001

Precautions for Supplemental Restraint System (SRS) “AIR BAG” and “SEAT BELT PRE-TENSIONER”

AIS00595

The Supplemental Restraint System such as “AIR BAG” and “SEAT BELT PRE-TENSIONER”, used along with a front seat belt, helps to reduce the risk or severity of injury to the driver and front passenger for certain types of collision. This system includes seat belt switch inputs and dual stage front air bag modules. The SRS system uses the seat belt switches to determine the front air bag deployment, and may only deploy one front air bag, depending on the severity of a collision and whether the front occupants are belted or unbelted. Information necessary to service the system safely is included in the SRS and SB section of this Service Manual.

WARNING:

- To avoid rendering the SRS inoperative, which could increase the risk of personal injury or death in the event of a collision which would result in air bag inflation, all maintenance must be performed by an authorized NISSAN/INFINITI dealer.
- Improper maintenance, including incorrect removal and installation of the SRS, can lead to personal injury caused by unintentional activation of the system. For removal of Spiral Cable and Air Bag Module, see the SRS section.
- Do not use electrical test equipment on any circuit related to the SRS unless instructed to in this Service Manual. SRS wiring harnesses can be identified by yellow and/or orange harnesses or harness connectors.

Precautions for Battery Service

AIS00596

Before disconnecting the battery, lower both the driver and passenger windows. This will prevent any interference between the window edge and the vehicle when the door is opened/closed. During normal operation, the window slightly raises and lowers automatically to prevent any window to vehicle interference. The automatic window function will not work with the battery disconnected.

Precautions

AIS00597

- Disconnect both battery cables in advance.
- Disconnect air bag system line in advance.
- Never tamper with or force air bag lid open, as this may adversely affect air bag performance.
- Be careful not to scratch pad and other parts.
- When removing or disassembling any part, be careful not to damage or deform it. Protect parts, which may get in the way with cloth.
- When removing parts with a screwdriver or other tool, protect parts by wrapping them with vinyl or tape.
- Keep removed parts protected with cloth.
- If a clip is deformed or damaged, replace it.
- If an un reusable part is removed, replace it with a new one.
- Tighten bolts and nuts firmly to the specified torque.
- After re-assembly has been completed, make sure each part functions correctly.
- Remove stains in the following way.

Water-soluble stains:

Dip a soft cloth in warm water, and then squeeze it tightly. After wiping the stain, wipe with a soft dry cloth.

Oil stain:

Dissolve a synthetic detergent in warm water (density of 2 to 3% or less), dip the cloth, then clean off the stain with the cloth. Next, dip the cloth in fresh water and squeeze it tightly. Then clean off the detergent completely. Then wipe the area with a soft dry cloth.

- Do not use any organic solvent, such as thinner or benzene.

PREPARATION

PREPARATION

PFP:00002

Special Service Tools

AIS00598

The actual shapes of Kent-Moore tools may differ from those of special service tools illustrated here.

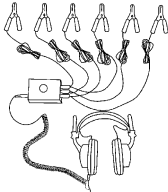
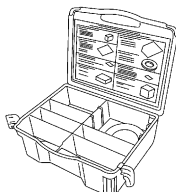
Tool number (Kent-Moore No.) Tool name	Description
(J39570) Chassis ear  SIIA0993E	Locating the noise
(J43980) NISSAN Squeak and Rattle Kit  SIIA0994E	Repairing the cause of noise

Commercial Service Tools

AIS00599

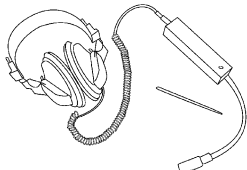
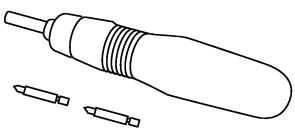
Tool name	Description
Engine ear  SIIA0995E	Locating the noise
Power tool  PBIC0191E	

SQUEAK AND RATTLE TROUBLE DIAGNOSES

SQUEAK AND RATTLE TROUBLE DIAGNOSES

PFP:00000

Work Flow

AI/S0059A

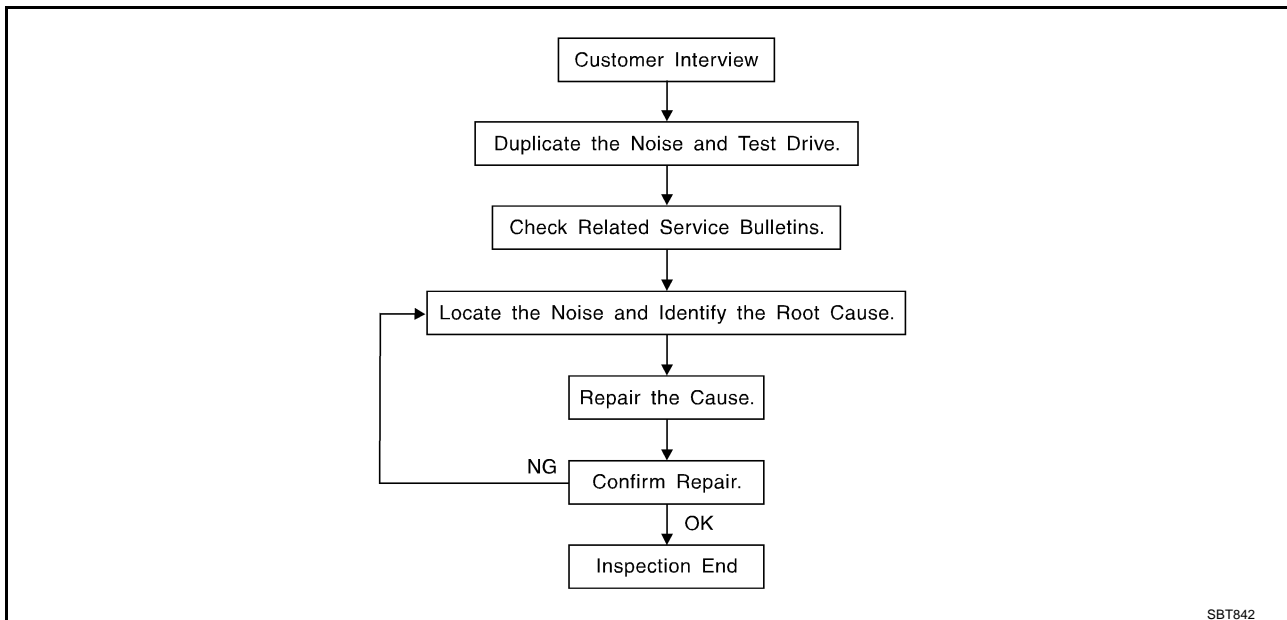

CUSTOMER INTERVIEW

Interview the customer if possible, to determine the conditions that exist when the noise occurs. Use the Diagnostic Worksheet during the interview to document the facts and conditions when the noise occurs and any customer's comments; refer to [IP-8, "Diagnostic Worksheet"](#). This information is necessary to duplicate the conditions that exist when the noise occurs.

- The customer may not be able to provide a detailed description or the location of the noise. Attempt to obtain all the facts and conditions that exist when the noise occurs (or does not occur).
- If there is more than one noise in the vehicle, be sure to diagnose and repair the noise that the customer is concerned about. This can be accomplished by test driving the vehicle with the customer.
- After identifying the type of noise, isolate the noise in terms of its characteristics. The noise characteristics are provided so the customer, service adviser and technician are all speaking the same language when defining the noise.
- Squeak —(Like tennis shoes on a clean floor)
Squeak characteristics include the light contact/fast movement/brought on by road conditions/hard surfaces=higher pitch noise/softer surfaces=lower pitch noises/edge to surface=chirping
- Creak—(Like walking on an old wooden floor)
Creak characteristics include firm contact/slow movement/twisting with a rotational movement/pitch dependent on materials/often brought on by activity.
- Rattle—(Like shaking a baby rattle)
Rattle characteristics include the fast repeated contact/vibration or similar movement/loose parts/missing clip or fastener/incorrect clearance.
- Knock —(Like a knock on a door)
Knock characteristics include hollow sounding/sometimes repeating/often brought on by driver action.
- Tick—(Like a clock second hand)
Tick characteristics include gentle contacting of light materials/loose components/can be caused by driver action or road conditions.
- Thump—(Heavy, muffled knock noise)
Thump characteristics include softer knock/dead sound often brought on by activity.
- Buzz—(Like a bumble bee)
Buzz characteristics include high frequency rattle/firm contact.
- Often the degree of acceptable noise level will vary depending upon the person. A noise that you may judge as acceptable may be very irritating to the customer.
- Weather conditions, especially humidity and temperature, may have a great effect on noise level.

SQUEAK AND RATTLE TROUBLE DIAGNOSES

DUPLICATE THE NOISE AND TEST DRIVE

If possible, drive the vehicle with the customer until the noise is duplicated. Note any additional information on the Diagnostic Worksheet regarding the conditions or location of the noise. This information can be used to duplicate the same conditions when you confirm the repair.

If the noise can be duplicated easily during the test drive, to help identify the source of the noise, try to duplicate the noise with the vehicle stopped by doing one or all of the following:

- 1) Close a door.
 - 2) Tap or push/pull around the area where the noise appears to be coming from.
 - 3) Rev the engine.
 - 4) Use a floor jack to recreate vehicle "twist".
 - 5) At idle, apply engine load (electrical load, half-clutch on M/T model, drive position on A/T model).
 - 6) Raise the vehicle on a hoist and hit a tire with a rubber hammer.
- Drive the vehicle and attempt to duplicate the conditions the customer states exist when the noise occurs.
 - If it is difficult to duplicate the noise, drive the vehicle slowly on an undulating or rough road to stress the vehicle body.

CHECK RELATED SERVICE BULLETINS

After verifying the customer concern or symptom, check ASIST for Technical Service Bulletins (TSBs) related to that concern or symptom.

If a TSB relates to the symptom, follow the procedure to repair the noise.

LOCATE THE NOISE AND IDENTIFY THE ROOT CAUSE

1. Narrow down the noise to a general area. To help pinpoint the source of the noise, use a listening tool (Chassis Ear: J39570, Engine Ear and mechanics stethoscope).
2. Narrow down the noise to a more specific area and identify the cause of the noise by:
 - removing the components in the area that you suspect the noise is coming from.
Do not use too much force when removing clips and fasteners, otherwise clips and fastener can be broken or lost during the repair, resulting in the creation of new noise.
 - tapping or pushing/pulling the component that you suspect is causing the noise.
Do not tap or push/pull the component with excessive force, otherwise the noise will be eliminated only temporarily.
 - feeling for a vibration with your hand by touching the component(s) that you suspect is (are) causing the noise.
 - placing a piece of paper between components that you suspect are causing the noise.
 - looking for loose components and contact marks.
Refer to [IP-6, "Generic Squeak and Rattle Troubleshooting"](#) .

REPAIR THE CAUSE

- If the cause is a loose component, tighten the component securely.
- If the cause is insufficient clearance between components:
 - separate components by repositioning or loosening and retightening the component, if possible.
 - insulate components with a suitable insulator such as urethane pads, foam blocks, felt cloth tape or urethane tape. A NISSAN Squeak and Rattle Kit (J43980) is available through your authorized NISSAN Parts Department.

CAUTION:

Do not use excessive force as many components are constructed of plastic and may be damaged.

Always check with the Parts Department for the latest parts information.

The following materials are contained in the NISSAN Squeak and Rattle Kit (J43980). Each item can be ordered separately as needed.

URETHANE PADS [1.5 mm (0.059 in) thick]

Insulates connectors, harness, etc.

76268-9E005: 100 × 135 mm (3.94 × 5.31 in)/76884-71L01: 60 × 85 mm (2.36 × 3.35 in)/76884-71L02: 15 × 25 mm (0.59 × 0.98 in)

INSULATOR (Foam blocks)

Insulates components from contact. Can be used to fill space behind a panel.

73982-9E000: 45 mm (1.77 in) thick, 50 × 50 mm (1.97 × 1.97 in)/73982-50Y00: 10 mm (0.39 in) thick, 50 × 50 mm (1.97 × 1.97 in)

SQUEAK AND RATTLE TROUBLE DIAGNOSES

INSULATOR (Light foam block)

80845-71L00: 30 mm (1.18 in) thick, 30 × 50 mm (1.18 × 1.97 in)

FELT CLOTH TAPE

Used to insulate where movement does not occur. Ideal for instrument panel applications.

68370-4B000: 15 × 25 mm (0.59 × 0.98 in) pad/68239-13E00: 5 mm (0.20 in) wide tape roll The following materials, not found in the kit, can also be used to repair squeaks and rattles.

UHMW (TEFLON) TAPE

Insulates where slight movement is present. Ideal for instrument panel applications.

SILICONE GREASE

Used in place of UHMW tape that will be visible or not fit.

Note: Will only last a few months.

SILICONE SPRAY

Use when grease cannot be applied.

DUCT TAPE

Use to eliminate movement.

CONFIRM THE REPAIR

Confirm that the cause of a noise is repaired by test driving the vehicle. Operate the vehicle under the same conditions as when the noise originally occurred. Refer to the notes on the Diagnostic Worksheet.

Generic Squeak and Rattle Troubleshooting

AIS0059B

Refer to Table of Contents for specific component removal and installation information.

INSTRUMENT PANEL

Most incidents are caused by contact and movement between:

1. The cluster lid A and instrument panel
2. Acrylic lens and combination meter housing
3. Instrument panel to front pillar garnish
4. Instrument panel to windshield
5. Instrument panel mounting pins
6. Wiring harnesses behind the combination meter
7. A/C defroster duct and duct joint

These incidents can usually be located by tapping or moving the components to duplicate the noise or by pressing on the components while driving to stop the noise. Most of these incidents can be repaired by applying felt cloth tape or silicon spray (in hard to reach areas). Urethane pads can be used to insulate wiring harness.

CAUTION:

Do not use silicone spray to isolate a squeak or rattle. If you saturate the area with silicone, you will not be able to recheck the repair.

CENTER CONSOLE

Components to pay attention to include:

1. Shifter assembly cover to finisher
2. A/C control unit and cluster lid C
3. Wiring harnesses behind audio and A/C control unit

The instrument panel repair and isolation procedures also apply to the center console.

DOORS

Pay attention to the:

1. Finisher and inner panel making a slapping noise
2. Inside handle escutcheon to door finisher
3. Wiring harnesses tapping
4. Door striker out of alignment causing a popping noise on starts and stops

Tapping or moving the components or pressing on them while driving to duplicate the conditions can isolate many of these incidents. You can usually insulate the areas with felt cloth tape or insulator foam blocks from the NISSAN Squeak and Rattle Kit (J43980) to repair the noise.

SQUEAK AND RATTLE TROUBLE DIAGNOSES

TRUNK

Trunk noises are often caused by a loose jack or loose items put into the trunk by the owner. In addition look for:

1. Trunk lid dumpers out of adjustment
2. Trunk lid striker out of adjustment
3. The trunk lid torsion bars knocking together
4. A loose license plate or bracket

Most of these incidents can be repaired by adjusting, securing or insulating the item(s) or component(s) causing the noise.

SUNROOF/HEADLINING

Noises in the sunroof/headlining area can often be traced to one of the following:

1. Sunroof lid, rail, linkage or seals making a rattle or light knocking noise
2. Sunvisor shaft shaking in the holder
3. Front or rear windshield touching headlining and squeaking

Again, pressing on the components to stop the noise while duplicating the conditions can isolate most of these incidents. Repairs usually consist of insulating with felt cloth tape.

SEATS

When isolating seat noise it's important to note the position the seat is in and the load placed on the seat when the noise is present. These conditions should be duplicated when verifying and isolating the cause of the noise.

Cause of seat noise include:

1. Headrest rods and holder
2. A squeak between the seat pad cushion and frame
3. The rear seatback lock and bracket

These noises can be isolated by moving or pressing on the suspected components while duplicating the conditions under which the noise occurs. Most of these incidents can be repaired by repositioning the component or applying urethane tape to the contact area.

UNDERHOOD

Some interior noise may be caused by components under the hood or on the engine wall. The noise is then transmitted into the passenger compartment.

Causes of transmitted underhood noise include:

1. Any component mounted to the engine wall
2. Components that pass through the engine wall
3. Engine wall mounts and connectors
4. Loose radiator mounting pins
5. Hood bumpers out of adjustment
6. Hood striker out of adjustment

These noises can be difficult to isolate since they cannot be reached from the interior of the vehicle. The best method is to secure, move or insulate one component at a time and test drive the vehicle. Also, engine RPM or load can be changed to isolate the noise. Repairs can usually be made by moving, adjusting securing, or insulating the component causing the noise.

A

B

C

D

E

F

G

H

IP

J

K

L

M

SQUEAK AND RATTLE TROUBLE DIAGNOSES

Diagnostic Worksheet

AIS0059C



SQUEAK & RATTLE DIAGNOSTIC WORKSHEET

Dear Infiniti Customer:

We are concerned about your satisfaction with your Infiniti vehicle. Repairing a squeak or rattle sometimes can be very difficult. To help us fix your Infiniti right the first time, please take a moment to note the area of the vehicle where the squeak or rattle occurs and under what conditions. You may be asked to take a test drive with a service advisor or technician to ensure we confirm the noise you are hearing.

I. WHERE DOES THE NOISE COME FROM? (circle the area of the vehicle)

The illustrations are for reference only, and may not reflect the actual configuration of your vehicle.

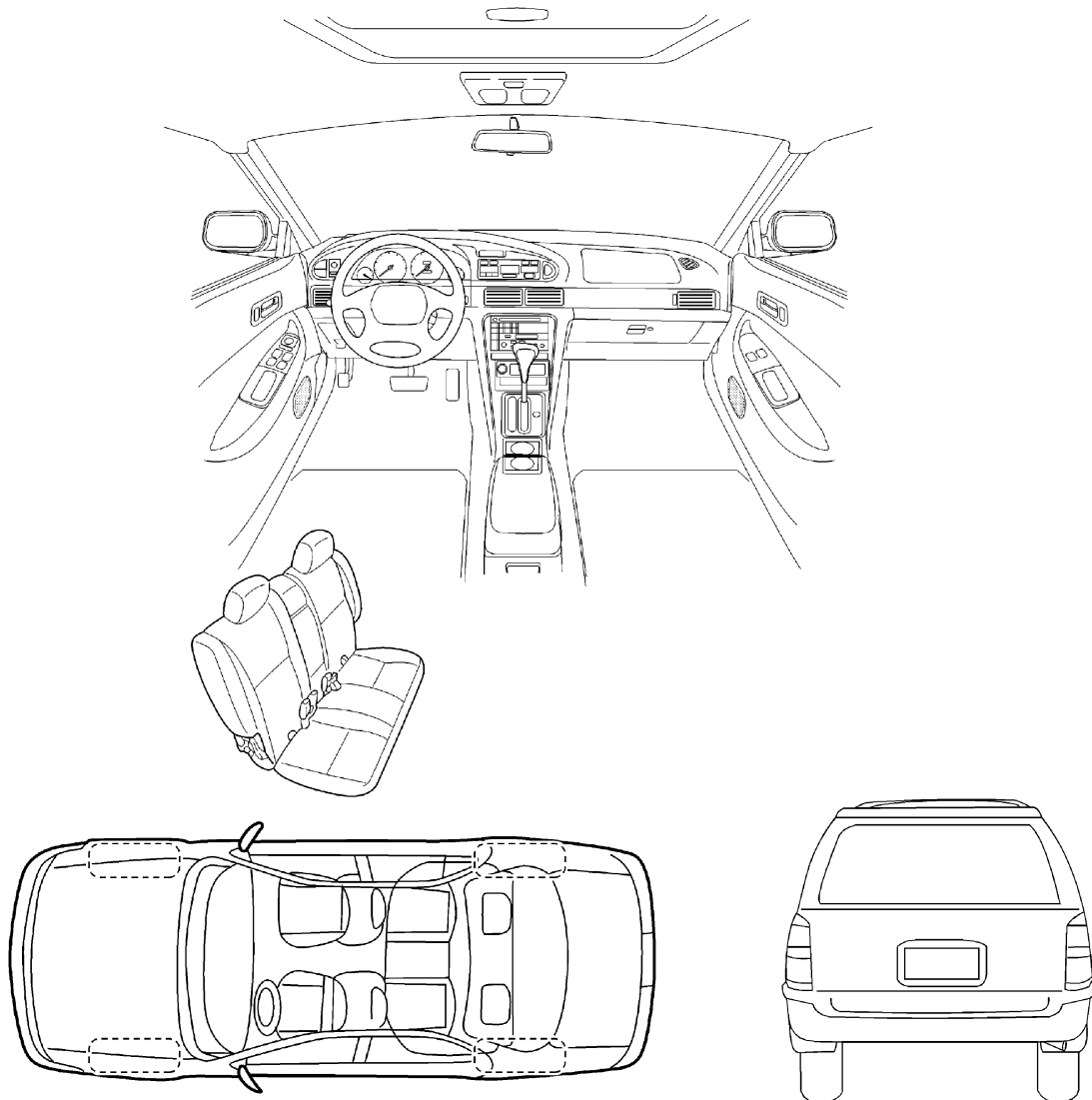

Continue to the back of the worksheet and briefly describe the location of the noise or rattle. In addition, please indicate the conditions which are present when the noise occurs.

SBT860

SQUEAK AND RATTLE TROUBLE DIAGNOSES

SQUEAK & RATTLE DIAGNOSTIC WORKSHEET- page 2

Briefly describe the location where the noise occurs:

II. WHEN DOES IT OCCUR? (check the boxes that apply)

- | | |
|--|---|
| <input type="checkbox"/> anytime | <input type="checkbox"/> after sitting out in the sun |
| <input type="checkbox"/> 1 st time in the morning | <input type="checkbox"/> when it is raining or wet |
| <input type="checkbox"/> only when it is cold outside | <input type="checkbox"/> dry or dusty conditions |
| <input type="checkbox"/> only when it is hot outside | <input type="checkbox"/> other: _____ |

III. WHEN DRIVING:

- through driveways
- over rough roads
- over speed bumps
- only at about ____ mph
- on acceleration
- coming to a stop
- on turns : left, right or either (circle)
- with passengers or cargo
- other: _____
- after driving ____ miles or ____ minutes

IV. WHAT TYPE OF NOISE?

- squeak (like tennis shoes on a clean floor)
- creak (like walking on an old wooden floor)
- rattle (like shaking a baby rattle)
- knock (like a knock on a door)
- tick (like a clock second hand)
- thump (heavy, muffled knock noise)
- buzz (like a bumble bee)

TO BE COMPLETED BY DEALERSHIP PERSONNEL

Test Drive Notes:

	YES	NO	Initials of person performing
Vehicle test driven with customer	<input type="checkbox"/>	<input type="checkbox"/>	_____
- Noise verified on test drive	<input type="checkbox"/>	<input type="checkbox"/>	_____
- Noise source located and repaired	<input type="checkbox"/>	<input type="checkbox"/>	_____
- Follow up test drive performed to confirm repair	<input type="checkbox"/>	<input type="checkbox"/>	_____

VIN: _____ Customer Name: _____

W.O. #: _____ Date: _____

This form must be attached to Work Order

INSTRUMENT PANEL ASSEMBLY

PFP:68200

AIS0059D

INSTRUMENT PANEL ASSEMBLY

Component Parts Drawing

SEC. 248•272•280•480•680•969

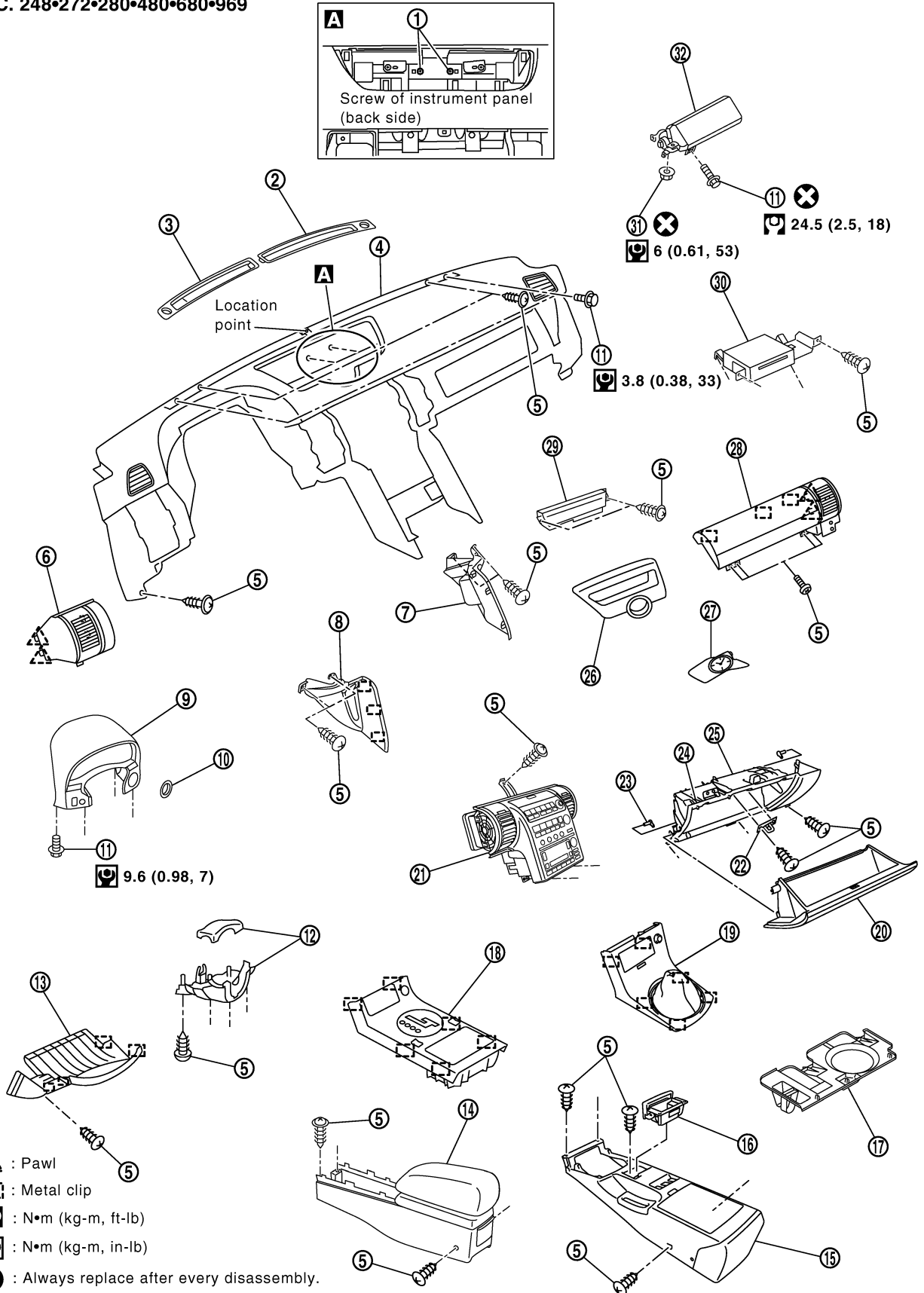

PIIB1058E

INSTRUMENT PANEL ASSEMBLY

- | | | |
|---|---|-----------------------------------|
| 1. Instrument panel and pad mounting screw (View A) | 2. Front defroster grille (RH) | 3. Front defroster grille (LH) |
| 4. Instrument panel and pad | 5. Screw | 6. Side ventilator grille (LH) |
| 7. Instrument side panel (RH) | 8. Instrument side panel (LH) | 9. Cluster lid A |
| 10. Steering lock escutcheon | 11. Bolt | 12. Steering column cover |
| 13. Instrument lower driver panel | 14. Center console (A/T Models) | 15. Center console (M/T Models) |
| 16. Ashtray | 17. Instrument lower cover | 18. Console finisher (A/T Models) |
| 19. Console boot (M/T Models) | 20. Glove box | 21. Cluster lid C |
| 22. Glove box striker | 23. Glove box pin | 24. Resin clip |
| 25. Instrument lower passenger panel | 26. Cluster lid finisher | 27. Clock |
| 28. Center box assembly | 29. Display unit and amplifier assembly | 30. NAVI control unit |
| 31. Nut | 32. Passenger air bag module | |

Removal and Installation WORK STEP

AIS0059E

When removing instrument panel and pad, combination meter, audio and display, NAVI control unit and center console, take steps in the order shown by the numbers below.

	Parts	Reference page	Instrument panel & pad	Combination meter	Audio and display unit	NAVI control unit	Center console
(A)	Steering lock escutcheon	IP-12	[1]	[1]			
(B)	Steering column covers	IP-12	[2]	[2]			
(C)	Instrument lower driver panel	IP-12	[3]	[3]	[1]	[1]	
(D)	Combination switch	IP-12	[4]	[4]			
(E)	Cluster lid A* ¹	IP-12	[5]	[5]			
(F)	Side ventilator grille (LH)	IP-12	[6]				
(G)	Selector knob (A/T Models)	AT-289	[7]		[2]	[2]	[1]
(H)	Shift knob (M/T Models)	MT-13	[7]		[2]	[2]	[1]
(I)	Console finisher (A/T Models)	IP-13	[8]		[3]	[3]	[2]
(J)	Console boot (M/T Models)	IP-13	[8]		[3]	[3]	[2]
(K)	Cluster lid finisher	IP-13	[9]		[4]	[4]	
(L)	Clock	DI-58	[10]		[5]	[5]	
(M)	Instrument lower cover	IP-13	[11]		[6]	[6]	
(N)	Instrument lower passenger panel and glove box	IP-13	[12]		[7]	[7]	
(O)	Instrument side panel (RH/LH)	IP-13	[13]		[8]	[8]	
(P)	Cluster lid C* ²	IP-14	[14]		[9]	[9]	
(Q)	Center box assembly	IP-14	[15]			[10]	
(R)	NAVI control unit	AV-110	[16]			[11]	
(S)	Display and amplifier	AV-111	[17]				
(T)	Passenger air bag module	SRS-41	[18]				
(U)	Center console (A/T Models)	IP-15	[19]				[3]
(V)	Center console (M/T Models)	IP-15	[19]				
(W)	Front defroster grille (RH/LH)	IP-15	[20]				

INSTRUMENT PANEL ASSEMBLY

	Parts	Reference page	Instrument panel & pad	Combination meter	Audio and display unit	NAVI control unit	Center console
(X)	Front pillar garnish (RH/LH)	EI-33	[21]				
(Y)	Instrument panel and pad	IP-15	[22]				

NOTE:

*1: When disassembling and assembling combination meter and mirror control switch, refer to [IP-17, "CLUSTER LID A"](#).

*2: When disassembling and assembling center ventilator grille, audio and display unit assembly and NAVI switch, refer to [IP-18, "CLUSTER LID C"](#).

REMOVAL

(A) Steering Lock Escutcheon

Pull to outside of vehicle, and remove steering lock escutcheon.

(B) Steering Column Covers

1. Remove screws.
2. Disconnect pawls, and remove upper and lower side of steering column covers.

(C) Instrument Lower Driver Panel

1. Remove screws.
2. Pull back to your side, disconnect metal clips and remove instrument lower driver panel.
3. Disconnect in-vehicle sensor and each electrical parts connectors.
4. Remove grommet, and remove hood lock cable.

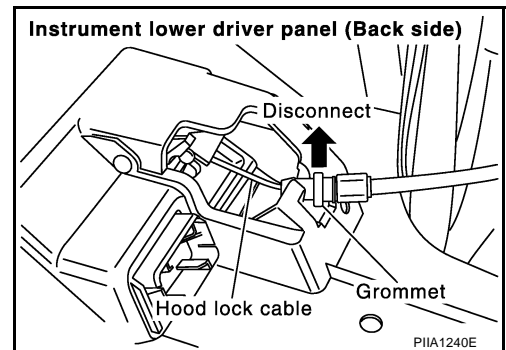

(D) Combination Switch

1. Remove bolts of cluster lid A.

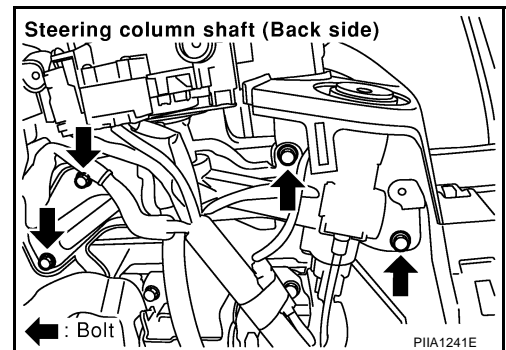

2. Remove pawl on upper and lower of combination switch.
3. Disconnect harness connector of wiper washer switch.
4. Use clothes to protect cluster lid A and combination switch from damage. Remove combination switch through gap between cluster lid A and steering wheel.

(E) Cluster Lid A

1. After removing bolts, disconnect harness connectors of combination meter and mirror control switch, and remove cluster lid A.
2. After removing cluster lid A, remove combination meter and mirror control switch. Refer to [IP-17, "CLUSTER LID A"](#).

(F) Side Ventilator Grille (LH)

Pull back to your side, disconnect metal clips and remove side ventilator grille.

INSTRUMENT PANEL ASSEMBLY

(G) Selector lever Knob (A/T Models)

Remove selector lever knob. Refer to [AT-289, "Control Device Removal and Installation"](#) .

(H) Shift Knob (M/T Models)

Remove shift knob. Refer to [MT-13, "SHIFT CONTROL"](#) .

(I) Console Finisher (A/T Models)

1. Put selector lever in drive position.
2. Remove metal clips from rear of console finisher, then remove metal clips at front. Pull console finisher upward to disengage from console.

CAUTION:

Guide pin inserted into A/T device guide can be easily broken. Be careful when removing it.

3. Disconnect harness connectors, and remove console finisher.
4. After removing, remove each parts from console finisher. Refer to [IP-20, "CENTER CONSOLE \(A/T MODELS\)"](#) .

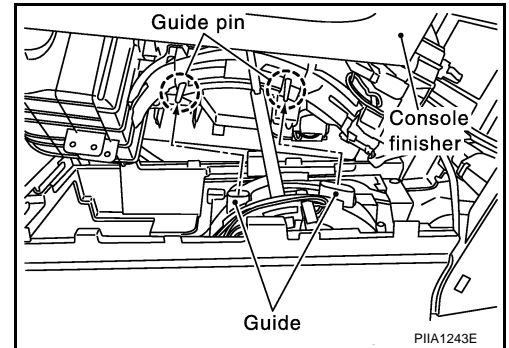

(J) Console Boot (M/T Models)

1. Insert a thin flat-bladed screwdriver wrapped with tape from behind console boot, and remove metal clip on back. Then pull up and back to disengage from front metal clip.
2. Disconnect hazard switch harness connector, and remove console boot.

(K) Cluster Lid Finisher

Disconnect metal clips and remove cluster lid finisher.

NOTE:

For easy removal, hold upper portion of lid, and pull lid upward to disengage metal clip. After that, pull it your side.

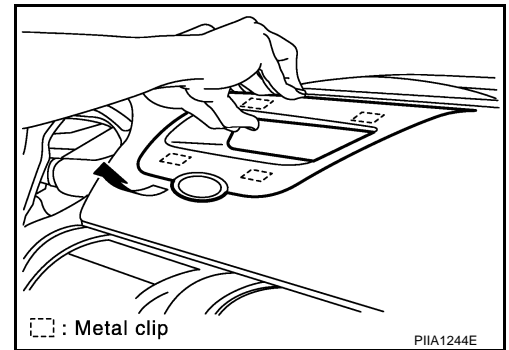

(L) Clock

Remove clock. Refer to [DI-58, "Removal and Installation of Clock"](#) .

(M) Instrument Lower Cover

Pull downward, disconnect metal clips, and remove instrument lower cover.

(N) Instrument Lower Passenger Panel and Glove Box

1. Remove screws with power tool.
2. Pull back to your side, and disconnect clips, and remove instrument lower passenger panel and glove box.
3. Remove screws of damper wire portion.
4. Disconnect glove box pins, and remove glove box.
5. Remove screws on back side of instrument lower passenger panel, and remove damper.

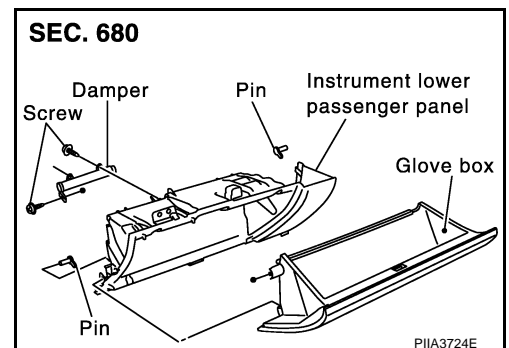

(O) Instrument Side Panel (RH/LH)

1. Remove screws.

INSTRUMENT PANEL ASSEMBLY

2. Pull to the side, disconnect metal clips and harness connector, and remove instrument side panel (RH/LH).

(P) Cluster Lid C

1. Remove screws with power tool.
2. Disconnect harness connector of display unit and audio unit, and remove it.

CAUTION:

- When removing, place clothes onto surrounding parts to protect A/T device and center console from damage.
- Unit is heavy [approximately 7 kg (15 lb)]. Be careful not to pinch your fingers.

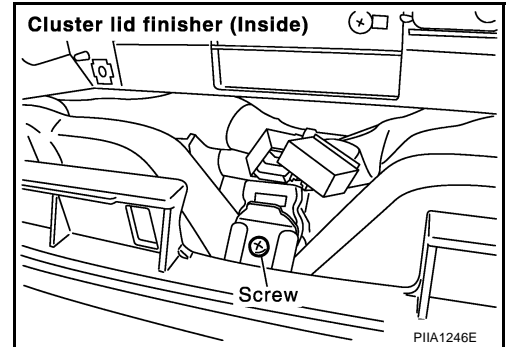

(Q) Center Box Assembly

1. Remove screws.
2. Hold left side of center box assembly, pull to outside of vehicle and disconnect metal clips. Remove center box assembly.

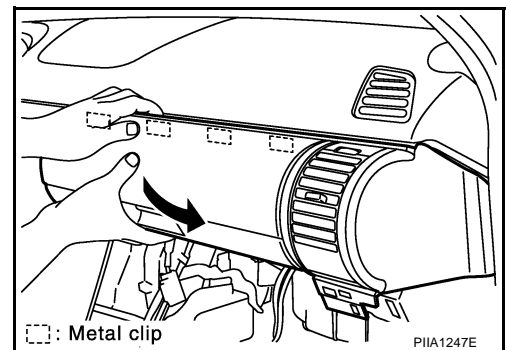

3. After removing, remove side ventilator grille and lid. Refer to [IP-19, "CENTER BOX ASSEMBLY"](#).

(R) NAVI Control Unit

Remove screws, and disconnect harness connector, and remove NAVI control unit. Refer to [AV-110, "Removal and Installation of NAVI Control Unit"](#).

(S) Display unit and Amplifier Assembly

Remove screws, and disconnect harness connector, and remove audio display and amplifier assembly. Refer to [AV-111, "Removal and Installation of Display Unit"](#).

(T) Passenger Air Bag Module

Remove bolts and nuts, and remove passenger air bag module. Refer to [SRS-41, "FRONT PASSENGER AIR BAG MODULE"](#).

INSTRUMENT PANEL ASSEMBLY

(U) Center Console (A/T Models)

1. Remove screws.
2. After removing, disassemble each parts. Refer to [IP-20, "CENTER CONSOLE \(A/T MODELS\)"](#) .

NOTE:

When removing console, be careful not to pull the harness.

(V) Center Console (M/T Models)

1. Remove screws.
2. Remove console sub-harness.
3. After removing, disassemble each parts. Refer to [IP-21, "CENTER CONSOLE \(M/T MODELS\)"](#) .

NOTE:

When removing console, be careful not to pull the harness.

(W) Front Defroster Grille (RH/LH)

Disconnect pawls with screwdriver wrapped in cloth and remove defroster grille.

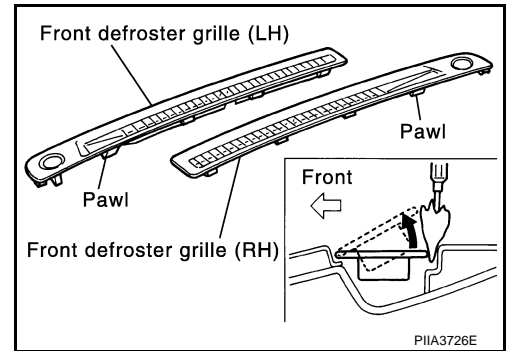

(X) Front Pillar Garnish (RH/LH)

Pull to inside of vehicle, disconnect metal clips and remove front pillar garnish. Refer to [EI-32, "BODY SIDE TRIM"](#) .

(Y) Instrument Panel and Pad

1. Lower steering column. Refer to [PS-10, "STEERING COLUMN"](#) .
2. Remove bolts and screws, and remove instrument panel and pad from passenger door opening portion.

INSTALLATION

To install, reverse the removal procedure sequence.
Assemble the following three parts carefully.

Console Finisher (A/T Models)

1. Put selector lever to driving position.
2. Put indicator panel to front side.
3. Connect each harness connectors.

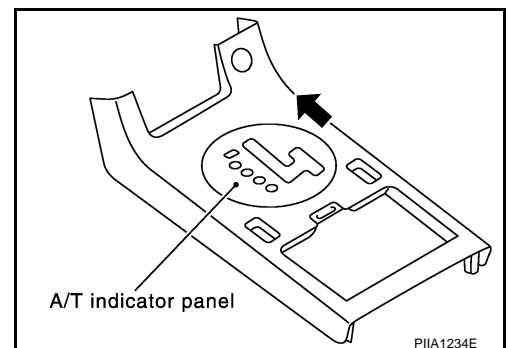

INSTRUMENT PANEL ASSEMBLY

4. While pushing forward and holding A/T indicator panel, engage metal clip at front of console finisher. Then insert guide pin into A/T device guide.

CAUTION:

Guide pin at back of console finisher can be easily broken. Be careful not to break it when working.

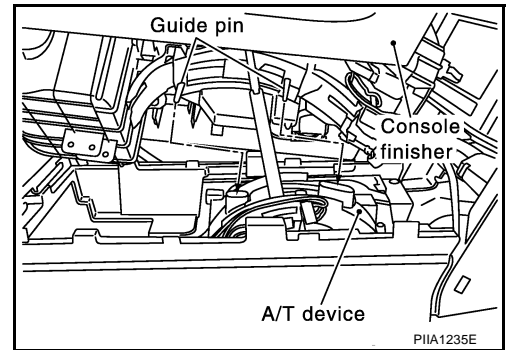

Console Boot (M/T Models)

1. Bring console boot to front side and connect front section metal clip.
2. After confirming secure connection of front section metal clip, connect rear section metal clip.

NOTE:

Insert securely to make sure there is no clearance of seam between lower section of cluster lid C and front section of center console.

Steering Column Shaft

When securing steering column shaft with bolts, position it so that both left and right gaps between instrument panel and steering column shaft become identical.

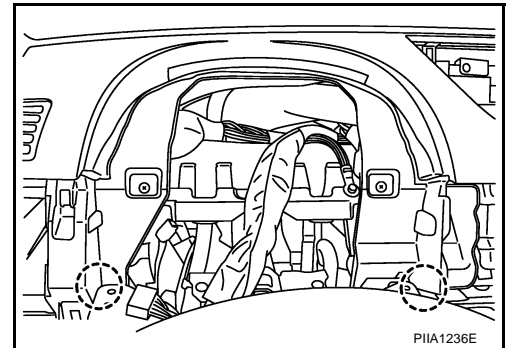

Instrument Lower Driver Panel

Inserting lower left clip is rather difficult. After installation ensure that clip is correctly inserted.

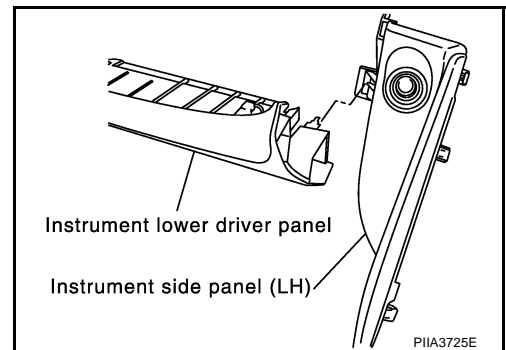

INSTRUMENT PANEL ASSEMBLY

Disassembly and Assembly CLUSTER LID A

AIS0059F

A
B
C
D
E
F
G
H
IP
J
K
L
M

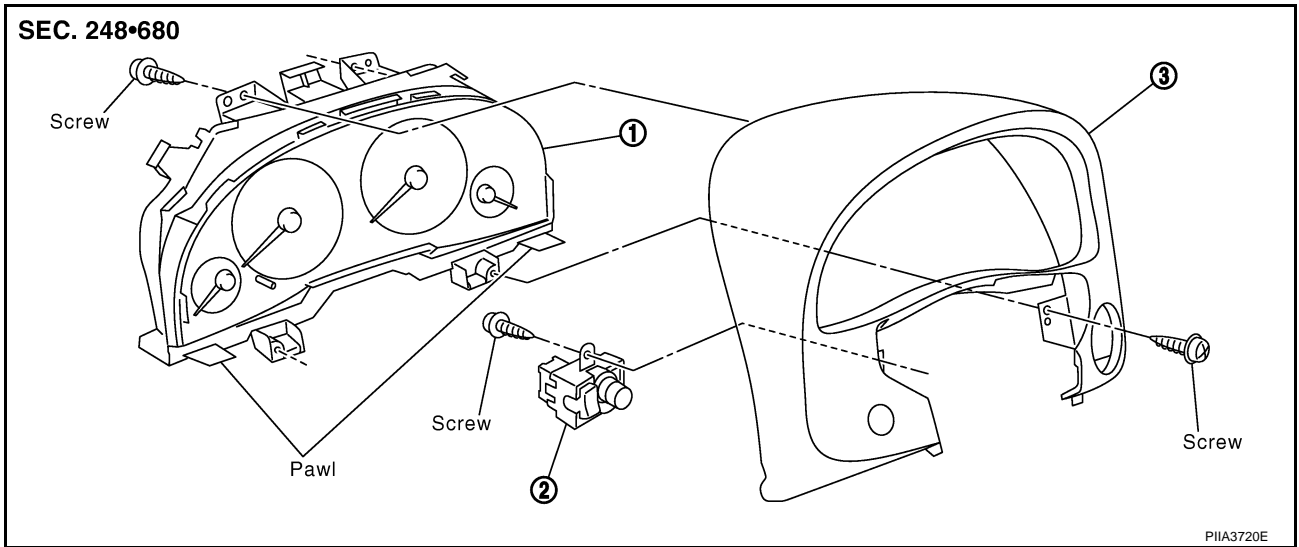

1. Combination meter

2. Mirror control switch

3. Cluster lid A

Disassembly

1. Remove screws, and then remove mirror control switch.
2. Remove screws and disconnect lower side of pawls, and then remove combination meter.

Assembly

Assemble in the reverse order of disassembly.

INSTRUMENT PANEL ASSEMBLY

CLUSTER LID C

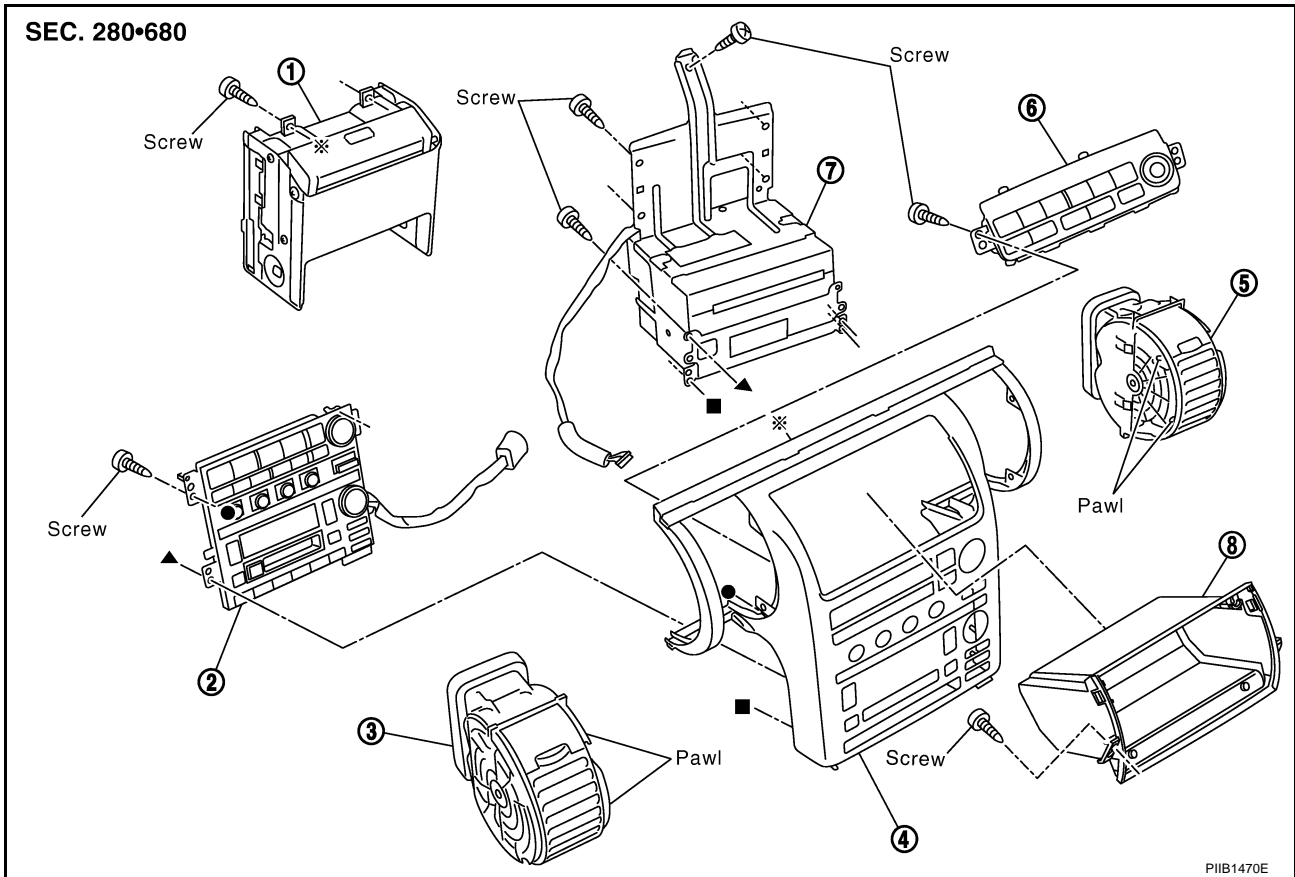

- | | | |
|----------------------|-------------------------------------|----------------------------------|
| 1. Display unit | 2. Control panel assembly | 3. Center ventilator grille (LH) |
| 4. Cluster lid C | 5. Center ventilator grille (RH) | 6. NAVI switch |
| 7. Audio and bracket | 8. Instrument pocket (without NAVI) | |

Disassembly

1. Disconnect pawl and remove center ventilator grille (RH side only).
2. Remove display unit assembly and audio unit, NAVI switch and control panel assembly.
Refer to [AV-35. "Removal and Installation for Audio Unit"](#) and [AV-36. "Removal and Installation for A/C and Audio Controller"](#).
3. Remove screws of instrument pocket, and then pull out instrument pocket. (without NAVI)

Assembly

Assemble in the reverse order of disassembly.

INSTRUMENT PANEL ASSEMBLY

CENTER BOX ASSEMBLY

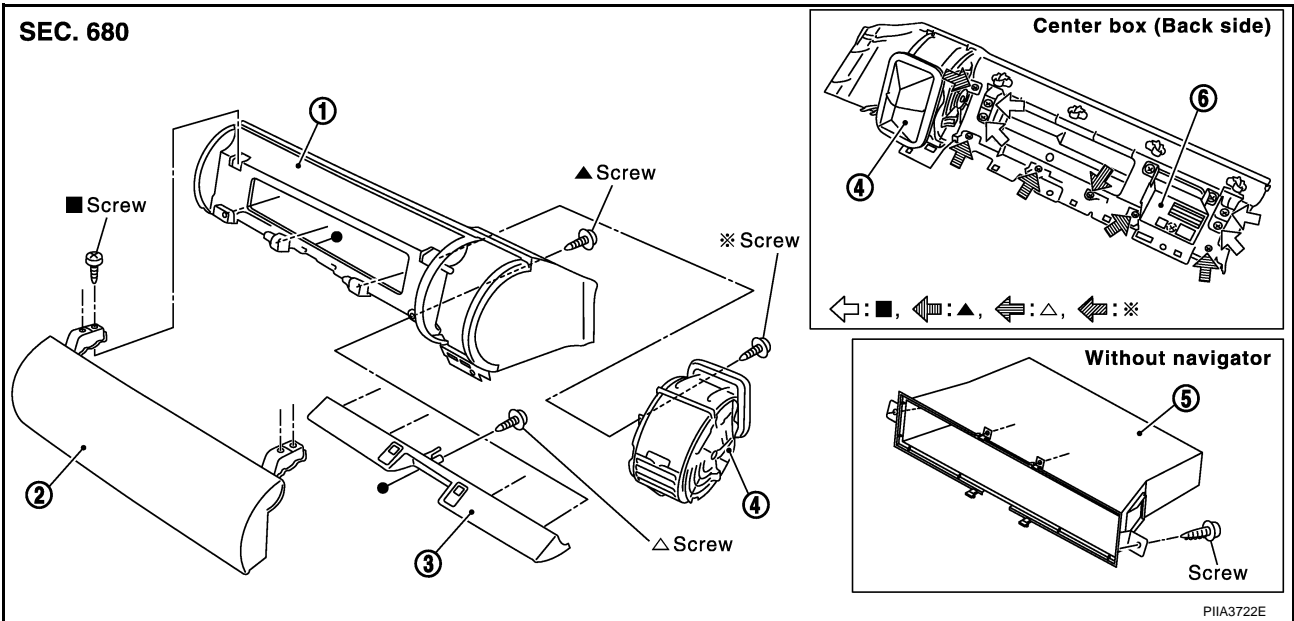

- | | | |
|--------------------------------|-------------------------|-------------------------|
| 1. Center box | 2. Center box upper lid | 3. Center box lower lid |
| 4. Side ventilator grille (RH) | 5. Pocket | 6. NAVI control unit |

Disassembly

1. Remove screws and pawls, and then remove side ventilator grille (RH).
2. Remove screws, and then remove NAVI control unit. Refer to [AV-110, "Removal and Installation of NAVI Control Unit"](#).
3. Remove screws, and then remove pocket (without NAVI models).
4. Remove screws, and then remove center box upper and lower lid.

Assembly

Assemble in the reverse order of disassembly.

A
B
C
D
E
F
G
H
IP
J
K
L
M

INSTRUMENT PANEL ASSEMBLY

CENTER CONSOLE (A/T MODELS)

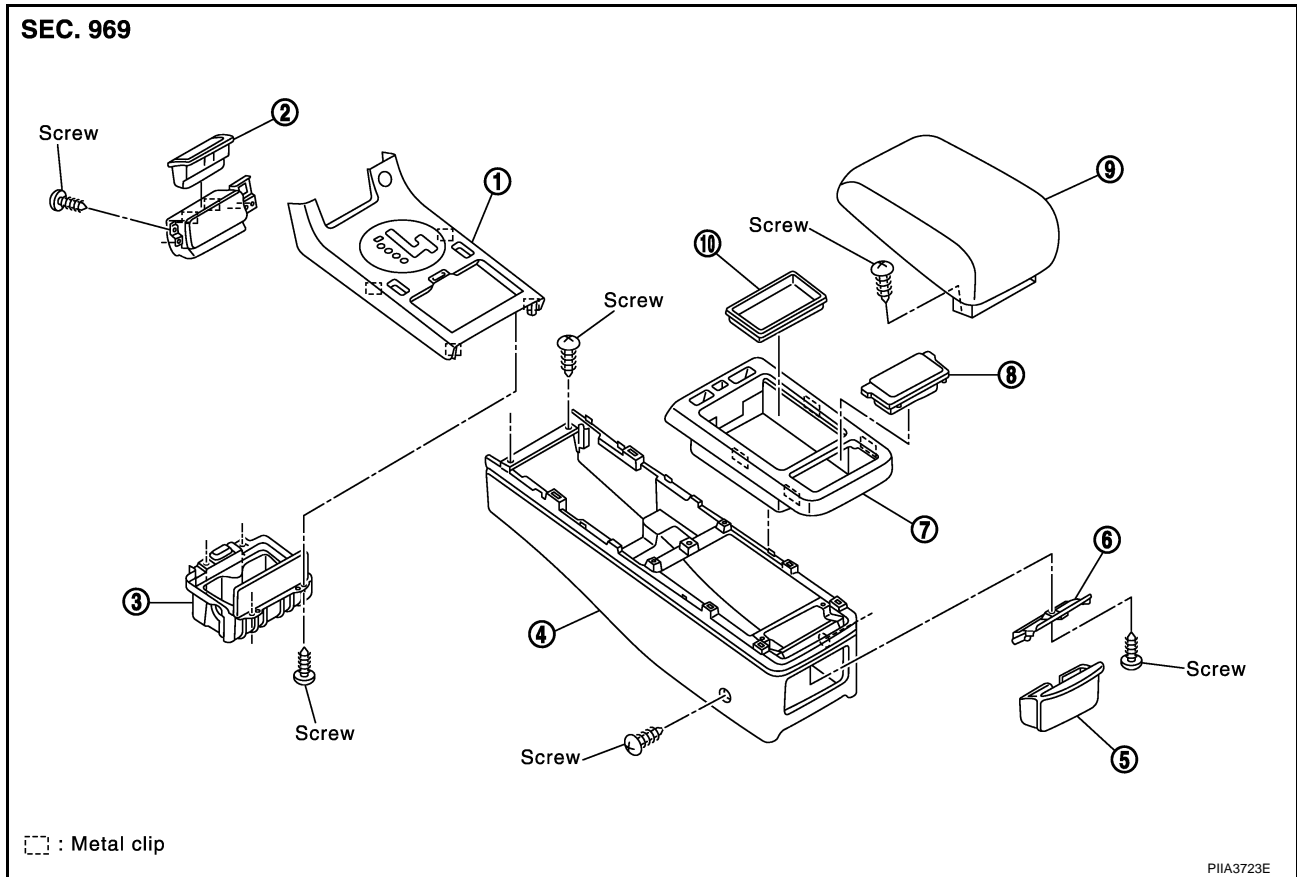

- | | | |
|---------------------------|------------------------------|--------------------|
| 1. Console finisher (A/T) | 2. Ashtray (front seat side) | 3. Cup holder |
| 4. Center console | 5. Ashtray (rear seat side) | 6. Ashtray bracket |
| 7. Console tray | 8. Console mask | 9. Console lid |
| 10. Console pocket | | |

Disassembly

1. Remove screws of back side (front), and remove ashtray (front portion).
2. Remove screws of back side (lower), and remove cup holder.
3. Remove console mask.
4. Remove screws and remove console lid.
5. Disconnect metal clips and remove rear ventilator from console lid.
6. Remove ashtray.
7. Remove screws and remove ashtray bracket.
8. Disconnect metal clips (back side), and remove console tray.

Assembly

Assemble in the reverse order of disassembly.

INSTRUMENT PANEL ASSEMBLY

CENTER CONSOLE (M/T MODELS)

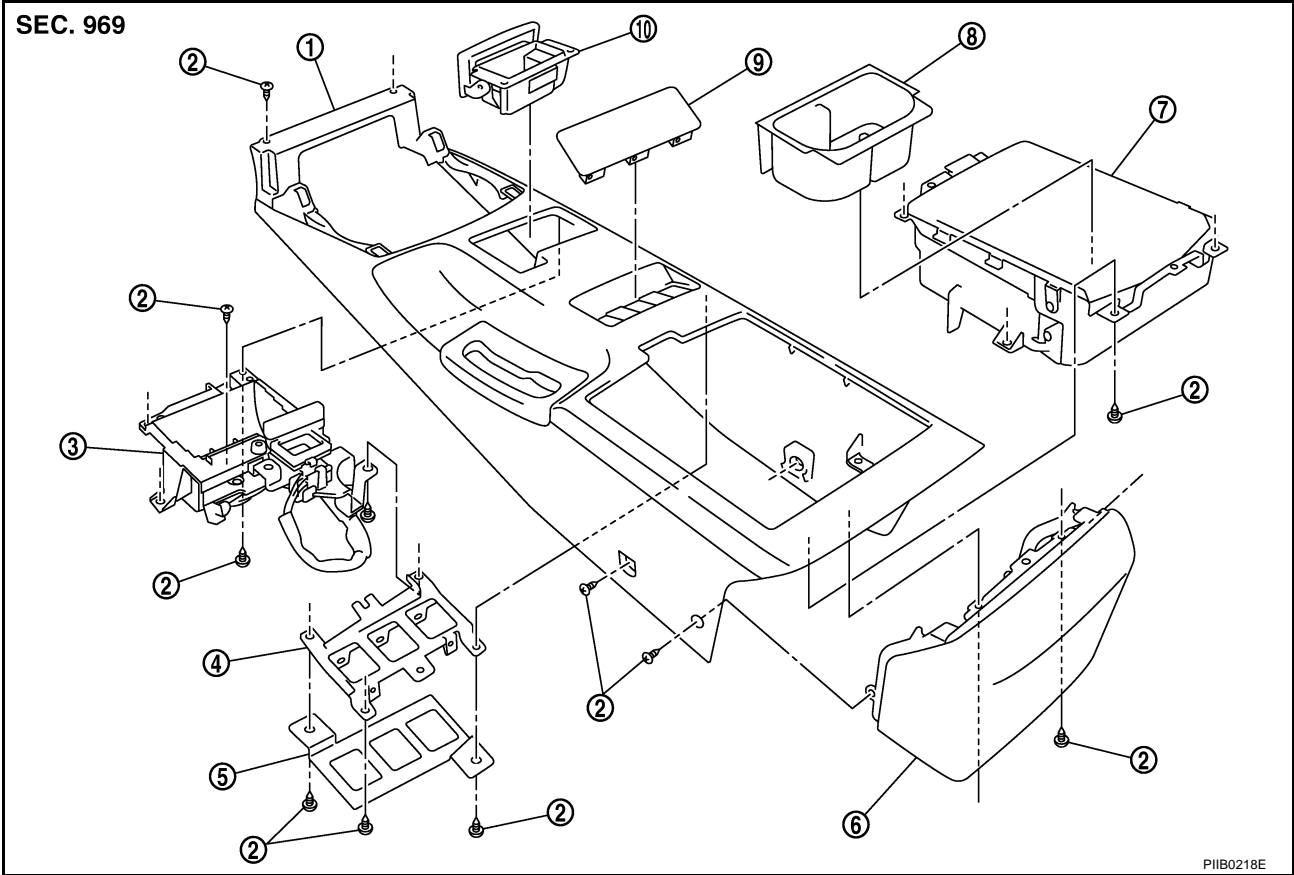

- | | | |
|------------------------|-----------------|--|
| 1. Center console | 2. Screw | 3. Ashtray bracket |
| 4. Switch bracket | 5. Bracket | 6. Rear finisher |
| 7. Console rear pocket | 8. Console tray | 9. Console cover mask/Seat heater switch |
| 10. Ashtray | | |

Disassembly

1. Remove ashtray.
2. Remove screws of back side, and then remove ashtray bracket.
3. Remove screws of back side, and then remove console rear pocket.
4. Remove console cover mask/seat heater switch.

Assembly

Assemble in the reverse order of disassembly.

A
B
C
D
E
F
G
H
IP
J
K
L
M

INSTRUMENT PANEL ASSEMBLY
