

A

CO

CO

SECTION

ENGINE COOLING SYSTEM

C

CONTENTS

D

E

<p>PRECAUTIONS 2</p> <p> Precautions for Supplemental Restraint System (SRS) "AIR BAG" and "SEAT BELT PRE-TENSIONER" 2</p> <p> Precautions for Battery Service 2</p> <p> Precautions for Liquid Gasket 2</p> <p> REMOVAL OF LIQUID GASKET SEALING 2</p> <p> LIQUID GASKET APPLICATION PROCEDURE.... 2</p> <p>PREPARATION 4</p> <p> Special Service Tools 4</p> <p> Commercial Service Tools 5</p> <p>OVERHEATING CAUSE ANALYSIS 6</p> <p> Troubleshooting Chart 6</p> <p>COOLING SYSTEM 8</p> <p> Cooling Circuit 8</p> <p>ENGINE COOLANT 9</p> <p> Inspection 9</p> <p> LEVEL CHECK 9</p> <p> LEAK CHECK 9</p> <p> Changing Engine Coolant 9</p> <p> DRAINING ENGINE COOLANT 9</p> <p> REFILLING ENGINE COOLANT 10</p> <p> FLUSHING COOLING SYSTEM 11</p> <p>RADIATOR 12</p> <p> Removal and Installation 12</p> <p> REMOVAL 12</p>	<p> INSTALLATION 13</p> <p> Disassembly and Assembly of Cooling Fan 14</p> <p> DISASSEMBLY 14</p> <p> ASSEMBLY 14</p> <p> CHECKING RADIATOR CAP 14</p> <p> CHECKING RADIATOR 15</p> <p>RADIATOR (ALUMINUM TYPE) 16</p> <p> Disassembly and Assembly 16</p> <p> PREPARATION 16</p> <p> DISASSEMBLY 16</p> <p> ASSEMBLY 17</p> <p> INSPECTION 19</p> <p>WATER PUMP 20</p> <p> Removal and Installation 20</p> <p> REMOVAL 20</p> <p> INSPECTION AFTER REMOVAL 22</p> <p> INSTALLATION 22</p> <p>THERMOSTAT AND THERMOSTAT HOUSING 24</p> <p> Removal and Installation 24</p> <p> REMOVAL 24</p> <p> INSPECTION AFTER REMOVAL 24</p> <p> INSTALLATION 25</p> <p>WATER OUTLET AND WATER PIPING 26</p> <p> Removal and Installation 26</p> <p> REMOVAL 26</p> <p> INSTALLATION 26</p> <p>SERVICE DATA AND SPECIFICATIONS (SDS) 27</p> <p> Capacity 27</p> <p> Thermostat 27</p> <p> Radiator 27</p> <p> Tightening Torque 27</p>
--	--

F

G

H

I

J

K

L

M

PRECAUTIONS

PRECAUTIONS

PFP:00001

Precautions for Supplemental Restraint System (SRS) “AIR BAG” and “SEAT BELT PRE-TENSIONER”

ABS00B4C

The Supplemental Restraint System such as “AIR BAG” and “SEAT BELT PRE-TENSIONER”, used along with a front seat belt, helps to reduce the risk or severity of injury to the driver and front passenger for certain types of collision. This system includes seat belt switch inputs and dual stage front air bag modules. The SRS system uses the seat belt switches to determine the front air bag deployment, and may only deploy one front air bag, depending on the severity of a collision and whether the front occupants are belted or unbelted. Information necessary to service the system safely is included in the SRS and SB section of this Service Manual.

WARNING:

- To avoid rendering the SRS inoperative, which could increase the risk of personal injury or death in the event of a collision which would result in air bag inflation, all maintenance must be performed by an authorized NISSAN/INFINITI dealer.
- Improper maintenance, including incorrect removal and installation of the SRS, can lead to personal injury caused by unintentional activation of the system. For removal of Spiral Cable and Air Bag Module, see the SRS section.
- Do not use electrical test equipment on any circuit related to the SRS unless instructed to in this Service Manual. SRS wiring harnesses can be identified by yellow and/or orange harnesses or harness connectors.

Precautions for Battery Service

ABS00B4D

Before disconnecting the battery, lower both the driver and passenger windows. This will prevent any interference between the window edge and the vehicle when the door is opened/closed. During normal operation, the window slightly raises and lowers automatically to prevent any window to vehicle interference. The automatic window function will not work with the battery disconnected.

Precautions for Liquid Gasket REMOVAL OF LIQUID GASKET SEALING

ABS004SN

- After removing the mounting bolts and nuts, separate the mating surface using a seal cutter and remove the liquid gasket sealing.

CAUTION:

Be careful not to damage the mating surfaces.

- In areas where the cutter is difficult to use, use a plastic hammer to lightly tap the areas where the liquid gasket is applied.

CAUTION:

If for some unavoidable reason a tool such as a flat-bladed screwdriver is used, be careful not to damage the mating surfaces.

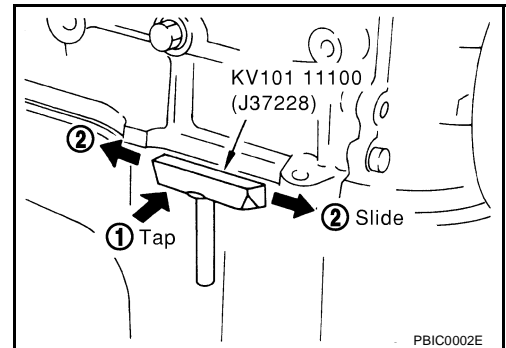

LIQUID GASKET APPLICATION PROCEDURE

1. Using a scraper, remove the old liquid gasket adhering to the liquid gasket application surface and the mating surface.
- Remove the liquid gasket completely from the groove of the liquid gasket application surface, mounting bolts, and bolt holes.
2. Wipe the liquid gasket application surface and the mating surface removing any adhering moisture, grease and foreign material.
3. Attach the liquid gasket tube to the tube presser.
- **Use Genuine RTV Silicone Sealant or equivalent. Refer to [GI-47, "RECOMMENDED CHEMICAL PRODUCTS AND SEALANTS"](#).**

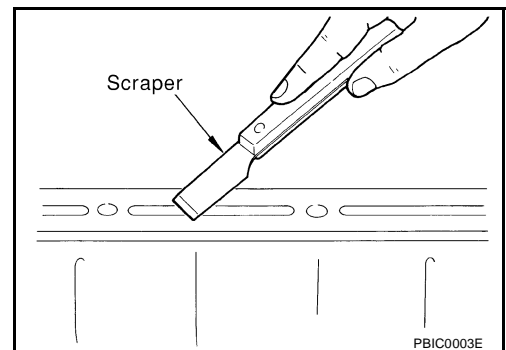

PRECAUTIONS

4. Apply the liquid gasket without breaks to the specified location with the specified dimensions.
 - If there is a groove for the liquid gasket application, apply the liquid gasket to the groove.

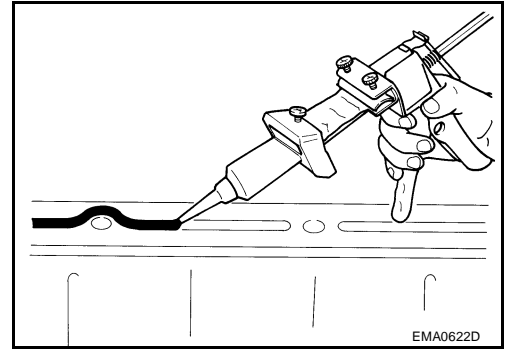

- As for the bolt holes, normally apply the liquid gasket inside the holes. Occasionally, it should be applied outside the holes. Make sure to read the text of this manual.
- Within five minutes of liquid gasket application, install the mating component.
- If the liquid gasket protrudes, wipe it off immediately.
- Do not retighten after the installation.
- After 30 minutes or more have passed from the installation, before fill the engine oil and engine coolant.

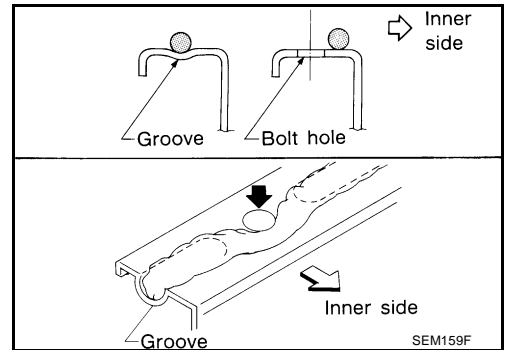

CAUTION:

If there are specific instructions in this manual, observe them.

A
CO
C
D
E
F
G
H
I
J
K
L
M

PREPARATION

PREPARATION

PFP:00002

Special Service Tools

ABS002XO

The actual shapes of Kent-Moore tools may from those of special service tools illustrated here.

Tool number (Kent-Moore No.) Tool name	Description
WS39930000 (-) Tube pressure	Pressing the tube of liquid gasket
EG17650301 (J33984-A) Radiator cap tester adapter	Adapting radiator cap tester to radiator cap and radiator filler neck a: 28 (1.10) dia. b: 31.4 (1.236) dia. c: 41.3 (1.626) dia. Unit: mm (in)
KV99103510 (-) Radiator plate pliers A	Installing radiator upper and lower tanks
KV99103520 (-) Radiator plate pliers B	Removing radiator upper and lower tanks
KV10111100 (J37228) Seal cutter	Removing chain tensioner cover and water pump cover

PREPARATION

Commercial Service Tools

ABS002XP

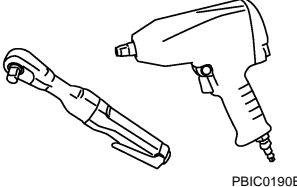
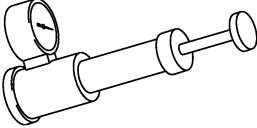
Tool name	Description	A
Power tool  PBIC0190E	Loosening bolts and nuts	CO
Radiator cap tester  PBIC1982E	Checking radiator and radiator cap	C
		D
		E
		F
		G
		H
		I
		J
		K
		L
		M

OVERHEATING CAUSE ANALYSIS

OVERHEATING CAUSE ANALYSIS

PFP:00012

Troubleshooting Chart

ABS002X0

		Symptom		Check items	
Cooling system parts malfunction	Poor heat transfer	Water pump malfunction	Worn or loose drive belt	—	
		Thermostat stuck closed	—		
		Damaged fins	Dust contamination or paper clogging		
			Physical damage		
		Clogged radiator cooling tube	Excess foreign material (rust, dirt, sand, etc.)		
	Reduced air flow	Cooling fan does not operate	Fan assembly	—	
		High resistance to fan rotation			
		Damaged fan blades			
		Damaged radiator shroud	—	—	—
		Improper engine coolant mixture ratio	—	—	—
		Poor engine coolant quality	—	Engine coolant viscosity	—
	Insufficient engine coolant	Engine coolant leaks	Cooling hose	Loose clamp	
				Cracked hose	
			Water pump	Poor sealing	
			Radiator cap	Loose	
Poor sealing					
Radiator		O-ring for damage, deterioration or improper fitting			
		Cracked radiator tank			
		Cracked radiator core			
	Reservoir tank	Cracked reservoir tank			
Overflowing reservoir tank	Exhaust gas leaks into cooling system	Cylinder head deterioration			
		Cylinder head gasket deterioration			

OVERHEATING CAUSE ANALYSIS

	Symptom		Check items				
Except cooling system parts malfunction	—	Overload on engine	Abusive driving	High engine rpm under no load	A		
				Driving in low gear for extended time	CO		
				Driving at extremely high speed	C		
					Powertrain system malfunction	—	D
					Installed improper size wheels and tires		E
					Dragging brakes		F
			Improper ignition timing	G			
	Blocked or restricted air flow	Blocked bumper	—		H		
		Blocked radiator grille	Installed car brassiere		I		
			Mud contamination or paper clogging		J		
		Blocked radiator	—		K		
		Blocked condenser	Blocked air flow		L		
Installed large fog lamp	M						

COOLING SYSTEM

COOLING SYSTEM

PFP:21020

Cooling Circuit

ABS002XR

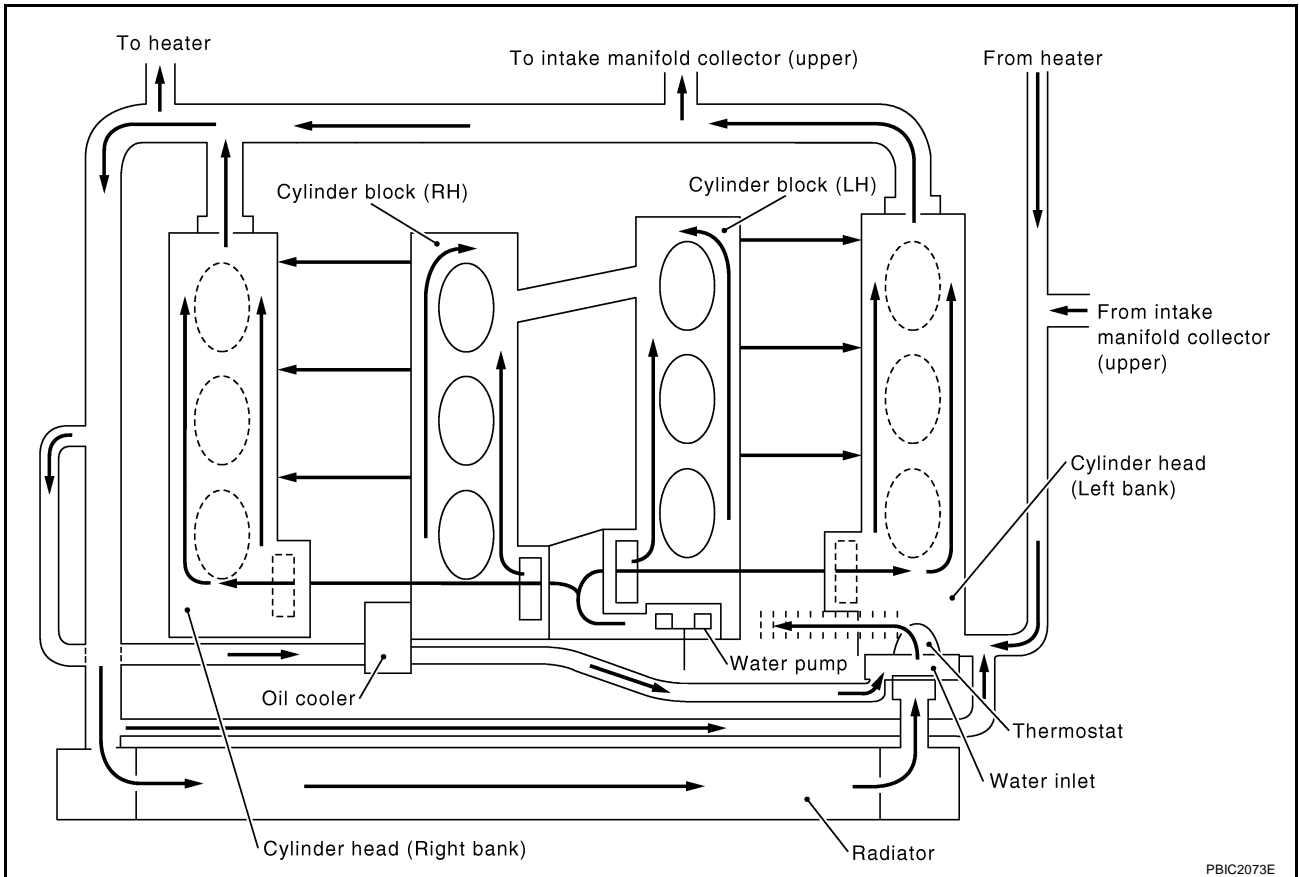

PBIC2073E

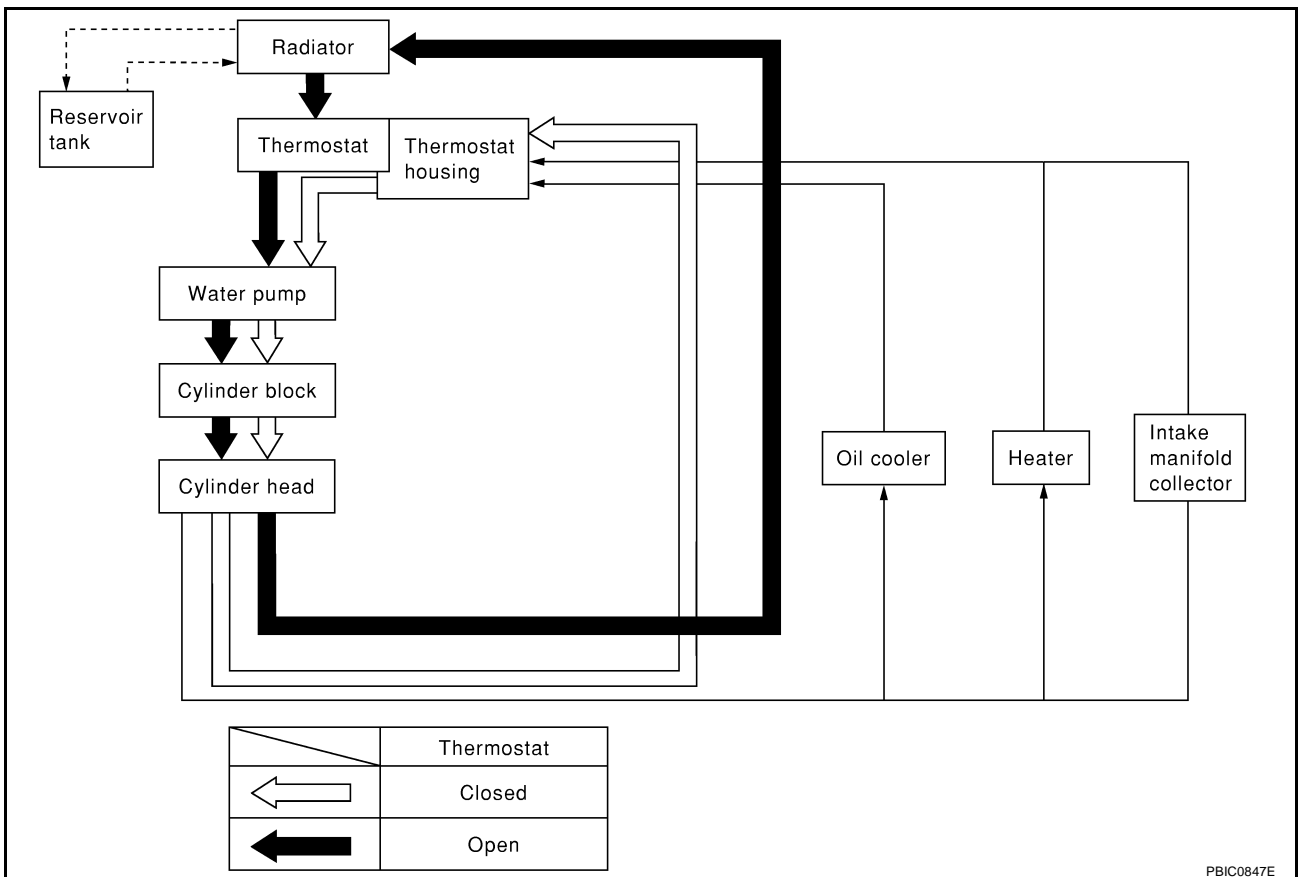

PBIC0847E

ENGINE COOLANT

ENGINE COOLANT

PFP:KQ100

Inspection LEVEL CHECK

ABS002XS

- Check if the reservoir tank engine coolant level is within the MIN. to MAX. when the engine is cool.
- Adjust the engine coolant level as necessary.

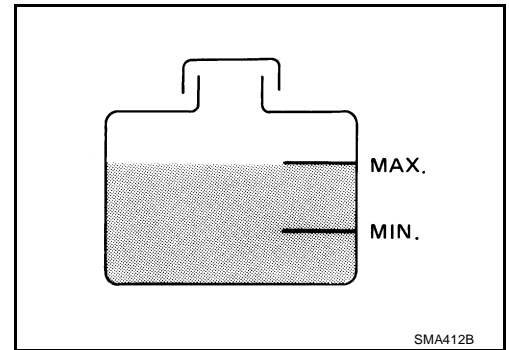

LEAK CHECK

- To check for leaks, apply pressure to the cooling system with radiator cap tester (commercial service tool) and radiator cap tester adapter (special service tool).

Testing pressure

: 157 kPa (1.6 kg/cm² , 23 psi)

WARNING:

Do not remove radiator cap when engine is hot. Serious burns could occur from high-pressure engine coolant escaping from radiator.

CAUTION:

Higher test pressure than specified may cause radiator damage.

NOTE:

In a case engine coolant decreases, replenish radiator with engine coolant.

- If anything is found, repair or replace damaged parts.

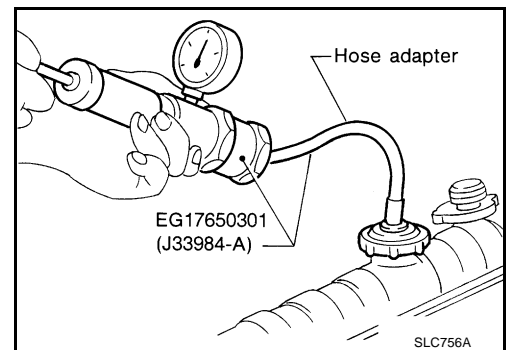

Changing Engine Coolant

ABS002XT

WARNING:

- To avoid being scalded, never change the engine coolant when the engine is hot.
- Wrap a thick cloth around cap and carefully remove the cap. First, turn the cap a quarter of a turn to release built-up pressure. Then turn the cap all the way.
- Be careful not to allow engine coolant to contact drive belts.

DRAINING ENGINE COOLANT

1. Remove engine undercover using power tools.
2. Open radiator drain plug at the bottom of radiator, and then remove radiator cap.

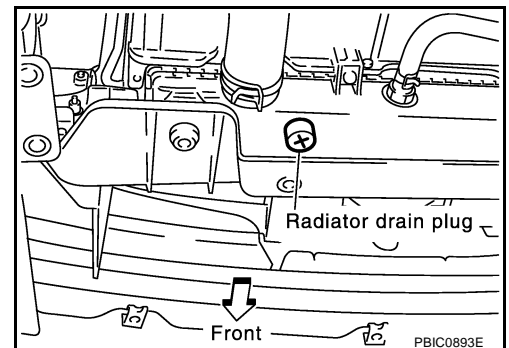

When drain all of engine coolant in the system, open drain plugs on engine cylinder block. Refer to [EM-99, "DISASSEMBLY"](#) .

3. Remove reservoir tank, drain engine coolant and clean tank before installing.

ENGINE COOLANT

4. Check drained engine coolant for contaminants such as rust, corrosion or discoloration.
If contaminated, flush the engine cooling system. Refer to [CO-11, "FLUSHING COOLING SYSTEM"](#).

REFILLING ENGINE COOLANT

1. Install reservoir tank, and radiator drain plug.

CAUTION:

Be sure to clean drain plug and install with new O-ring.

Radiator drain plug:

: 1.2 N·m (0.12 kg·m, 11 in·lb)

If cylinder block drain plugs are removed, close and tighten them. Refer to [EM-103, "ASSEMBLY"](#).

2. Remove air relief plug on heater hose.

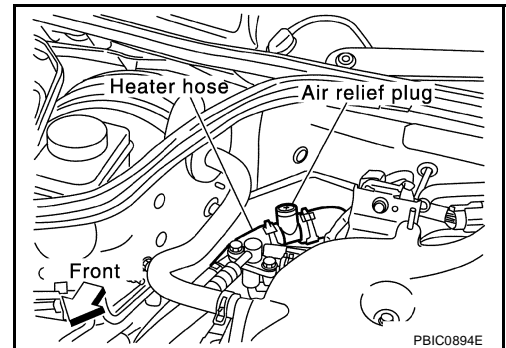

3. Fill radiator and reservoir tank to specified level.

- Pour engine coolant through engine coolant filler neck slowly of less than 2 ℓ (2-1/8 US qt, 1-3/4 Imp qt) a minute to allow air in system to escape.
- Use Genuine Nissan Anti-freeze coolant or equivalent mixed with water (distilled or demineralized). Refer to [MA-9, "RECOMMENDED FLUIDS AND LUBRICANTS"](#).

Engine coolant capacity

(With reservoir tank at "MAX" level)

: Approx. 8.7 ℓ (9-1/4 US qt, 7-5/8 Imp qt)

Reservoir tank capacity (At "MAX" level)

: 0.8 ℓ (7/8 US qt, 3/4 Imp qt)

- When engine coolant overflows air relief hole on heater hose, install air relief plug with new O-ring.

Air relief plug:

: 0.78 - 1.6 N·m (0.08 - 0.16 kg·m, 7 - 14 in·lb)

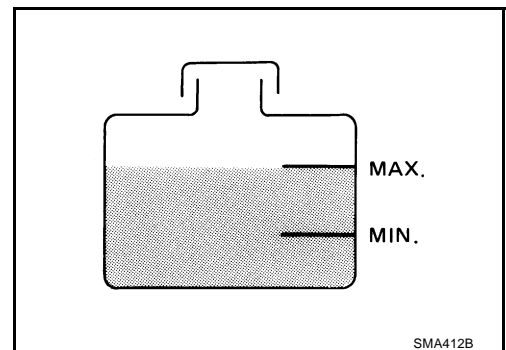
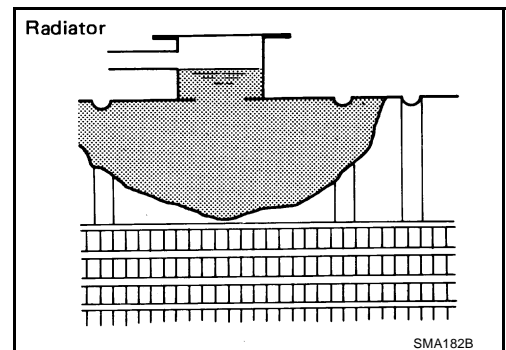

4. Install radiator cap.
5. Warm up until opening thermostat. Standard for warming-up time is approximately 10 minutes at 3,000 rpm.
 - Make sure thermostat opening condition by touching radiator hose (lower) to see a flow of warm water.
6. Stop engine and cool down to less than approximately 50°C (122°F).
 - Cool down using fan to reduce the time.
 - If necessary, refill radiator up to filler neck with engine coolant.
7. Refill reservoir tank to "MAX" level line with engine coolant.

CAUTION:

Watch water temperature gauge so as not to overheat engine.

ENGINE COOLANT

8. Repeat steps 3 through 6 two or more times with radiator cap installed until engine coolant level no longer drops.
9. Check cooling system for leaks with engine running.
10. Warm up engine, and check for sound of engine coolant flow while running engine from idle up to 3,000 rpm with heater temperature controller set at several position between "COOL" and "WARM".
 - Sound may be noticeable at heater unit.
11. Repeat step 10 three times.
12. If sound is heard, bleed air from cooling system by repeating step 3 through 6 until engine coolant level no longer drops.
 - **Clean excess engine coolant from engine.**

FLUSHING COOLING SYSTEM

1. Install reservoir tank if removed, and radiator drain plug.

CAUTION:

Be sure to clean drain plug and install with new O-ring.

Radiator drain plug:

 **1.2 N·m (0.12 kg·m, 11 in-lb)**

If cylinder block water drain plugs are removed, close and tighten them. Refer to [EM-103, "ASSEMBLY"](#).

2. Fill radiator with water until water spills from the air relief hole, then close air relief plug. Fill radiator and reservoir tank with water and reinstall radiator cap.
3. Run engine and warm it up to normal operating temperature.
4. Rev engine two or three times under no-load.
5. Stop engine and wait until it cools down.
6. Drain the water from the system. Refer to [CO-9, "DRAINING ENGINE COOLANT"](#).
7. Repeat steps 1 through 6 until clear water begins to drain from radiator.

A

CO

C

D

E

F

G

H

I

J

K

L

M

RADIATOR

PFP:21400

ABS002XU

RADIATOR

Removal and Installation

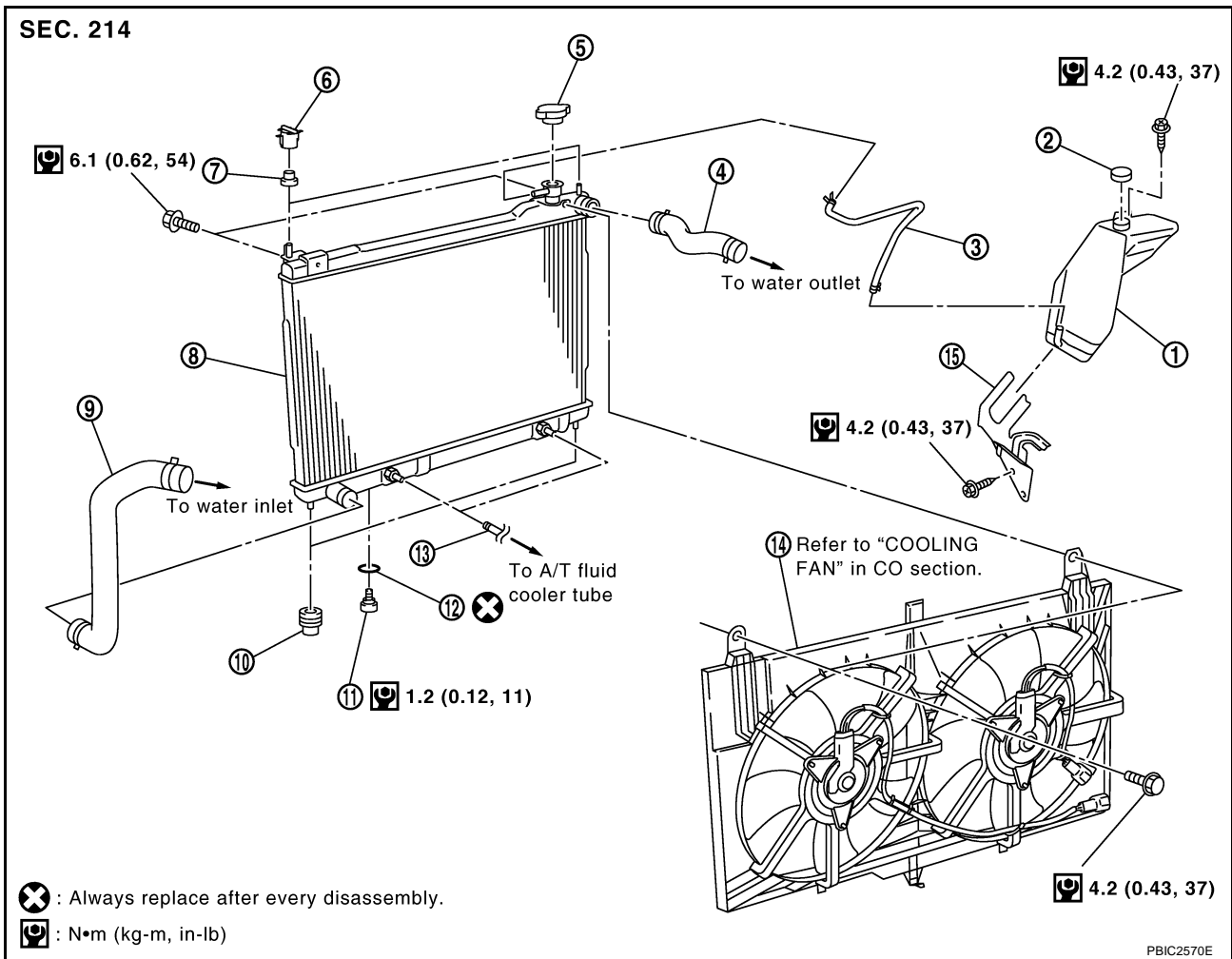

- | | | |
|-----------------------------|-----------------------------------|--------------------------|
| 1. Reservoir tank | 2. Cap | 3. Reservoir tank hose |
| 4. Radiator hose (upper) | 5. Radiator cap | 6. Upper mount bracket |
| 7. Mounting rubber (upper) | 8. Radiator | 9. Radiator hose (lower) |
| 10. Mounting rubber (lower) | 11. Radiator drain plug | 12. O-ring |
| 13. A/T fluid cooler hose | 14. Radiator cooling fan assembly | 15. Bracket |

WARNING:

Never remove the radiator cap when the engine is hot. Serious burns could occur from high pressure engine coolant escaping from the radiator.

REMOVAL

1. Remove undercover using power tool.
2. Drain engine coolant from the radiator. Refer to [CO-9, "Changing Engine Coolant"](#).

CAUTION:

perform when the engine is cold.

3. Remove air duct and air cleaner case. Refer to [EM-14, "Removal and Installation"](#).
4. Remove reservoir tank and bracket.
5. Disconnect A/T fluid cooler hoses.(A/T model only)
 - Install blind plug to avoid leakage of A/T fluid.
6. Disconnect radiator upper and lower hoses.
7. Remove radiator cooling fan assembly.

RADIATOR

8. Rotate two radiator upper mount brackets 90 degrees in the direction shown in the figure, and remove them.
9. Remove bracket mounting bolt for anchoring air conditioner piping from vehicle left side, so that air conditioner piping can be moved.

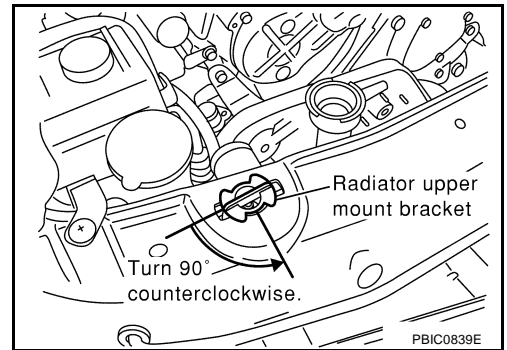

10. Remove two air conditioner condenser mounting bolts located in upper part of radiator.

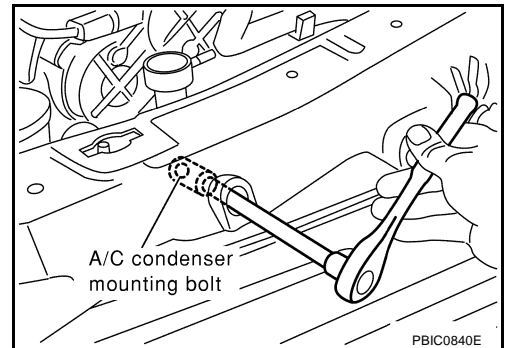

11. Lift the air conditioner condenser up approximately 2cm (0.79in).

CAUTION:

To avoid putting a load on the air conditioner piping, be careful not to lift too much.

12. Lift up and remove the radiator.

CAUTION:

- Do not damage or scratch air conditioner condenser and radiator core when removing.
- After removing the radiator, fix the air conditioner condenser on the vehicle side with a rope or similar means. This is to prevent a load being applied to the air conditioner piping.

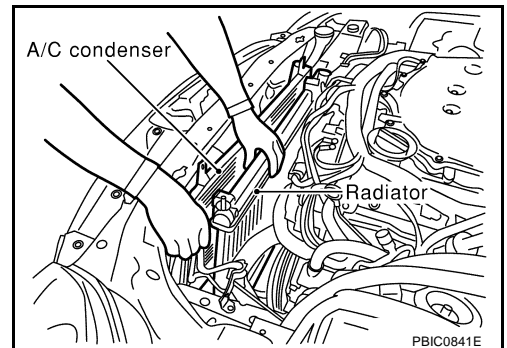

INSTALLATION

- Install in the reverse order of removal.

A
CO
C
D
E
F
G
H
I
J
K
L
M

RADIATOR

Disassembly and Assembly of Cooling Fan

ABS004SK

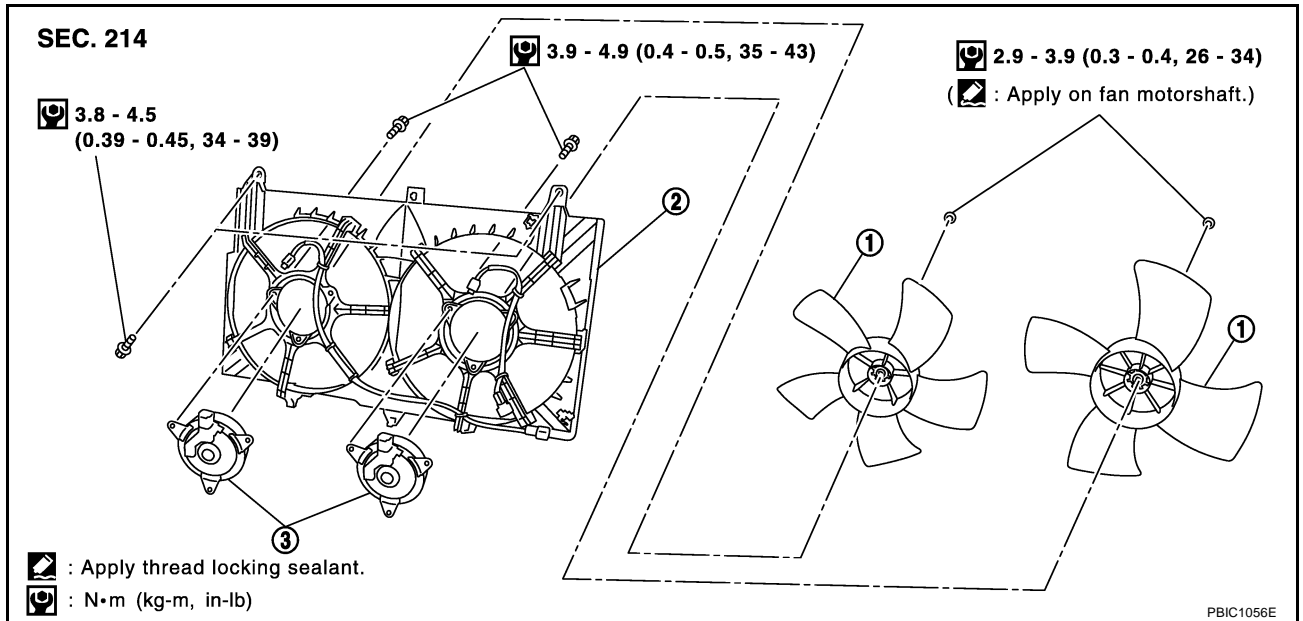

1. Cooling fan

2. Fan shroud

3. Fan motors

DISASSEMBLY

1. Remove cooling fan from fan motor.
2. Remove fan motor from fan shroud.

ASSEMBLY

- Install in the reverse order of removal.

CHECKING RADIATOR CAP

1. Pull the negative-pressure valve to open it and check that it closes completely when released.
 - Check that there is no dirt or damage on the valve seat of the radiator cap negative-pressure valve.
 - Check that there are no unusualness in the opening and closing conditions of the negative-pressure valve.

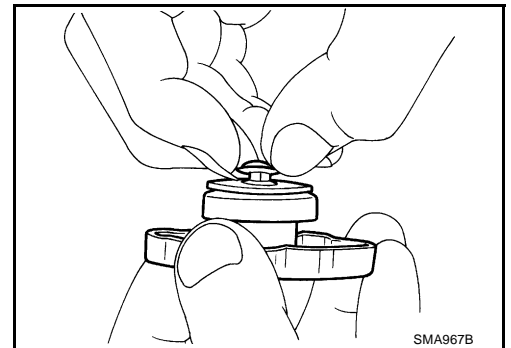

2. Check radiator cap relief pressure.

Standard:

78 - 98 kPa (0.8 - 1.0 kg/cm² , 11 - 14 psi)

Limit:

59 kPa (0.6 kg/cm² , 9 psi)

- When connecting radiator cap to radiator cap tester (commercial service tool) and radiator cap tester adapter (special service tool), apply engine coolant to the cap seal surface.
- Replace radiator cap if there is an unusualness in negative-pressure valve, or if the relief pressure falls below the limit.

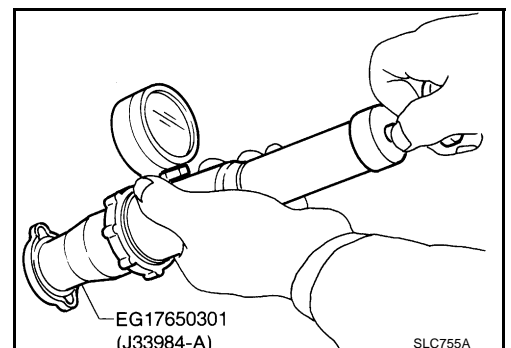

RADIATOR

CHECKING RADIATOR

Check radiator for mud or clogging. If necessary, clean radiator as follows.

- Be careful not to bend or damage the radiator fins.
 - When radiator is cleaned without removal, remove all surrounding parts such as cooling fan, radiator shroud and horns. Then tape the harness and electrical connectors to prevent water from entering.
1. Apply water by hose to the back side of the radiator core vertically downward.
 2. Apply water again to all radiator core surface once per minute.
 3. Stop washing if any stains no longer flow out from the radiator.
 4. Blow air into the back side of radiator core vertically downward.
 - Use compressed air lower than 490 kPa (5 kg/cm² , 71 psi) and keep distance more than 30 cm (11.8 in).
 5. Blow air again into all the radiator core surfaces once per minute until no water sprays out.

A

CO

C

D

E

F

G

H

I

J

K

L

M

RADIATOR (ALUMINUM TYPE)

PFP:21460

RADIATOR (ALUMINUM TYPE)

Disassembly and Assembly

ABS002XV

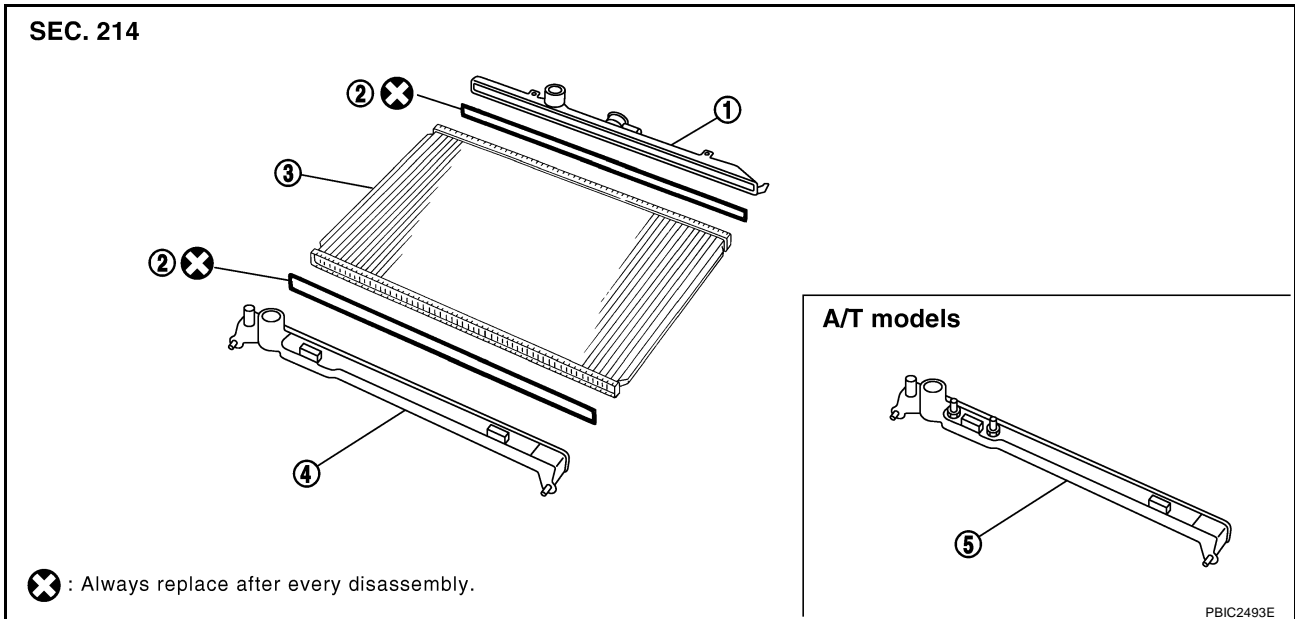

1. Upper tank
2. Sealing rubber
3. Core
4. Lower tank
5. Lower tank (with A/T fluid cooler)

PREPARATION

1. Attach the spacer to the tip of radiator plate pliers A (special service tool).
Spacer specification: 18 mm (0.71 in) wide × 8.5 mm (0.335 in) long × 1.5 mm (0.059 in) thick.

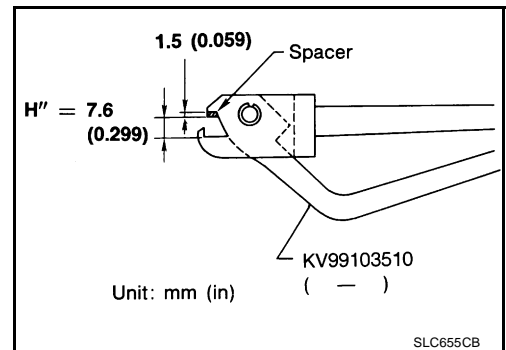

2. Make sure that when radiator plate pliers A [special service tool: KV99103510 (—)] are closed dimension H'' is approx. 7.6 mm (0.299 in).
3. Adjust dimension H'' with the spacer thickness, if necessary.

DISASSEMBLY

1. Remove upper and lower tanks with radiator plate pliers B (special service tool).

CAUTION:

Do not disassemble lower tank and A/T fluid cooler.

NOTE:

Regard lower tank and A/T fluid cooler as an assembly.

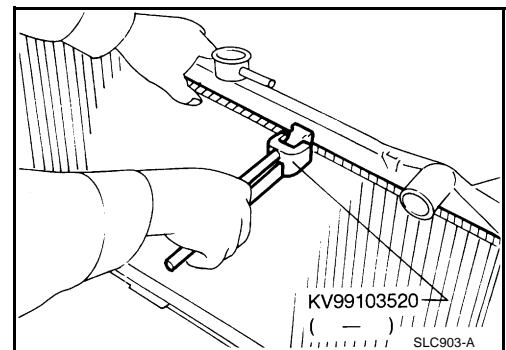

RADIATOR (ALUMINUM TYPE)

- Grip the crimped edge and bend it upwards so that radiator plate pliers B slips off.

CAUTION:

Do not bend excessively.

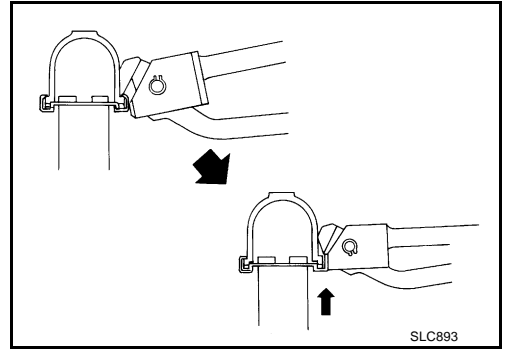

- In areas where radiator plate pliers B cannot be used, use screwdriver to bend the edge up.

CAUTION:

Be careful not to damage tank.

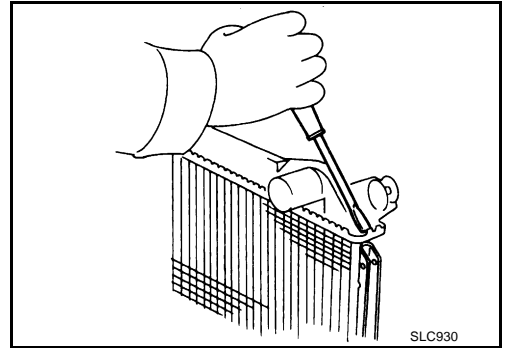

2. Remove sealing rubber.
3. Make sure the edge stands straight up.

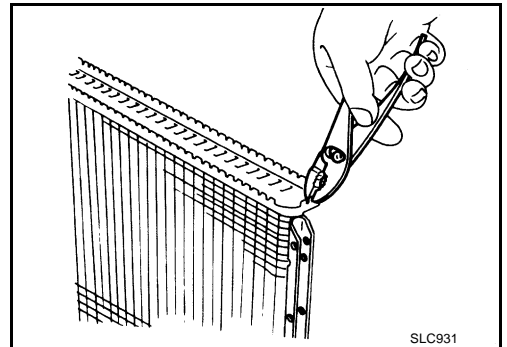

ASSEMBLY

1. Clean contact portion of tank.

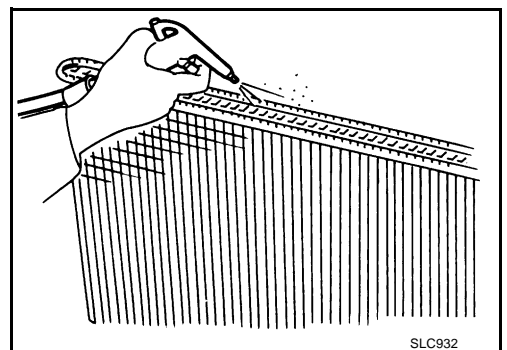

A
CO
C
D
E
F
G
H
I
J
K
L
M

RADIATOR (ALUMINUM TYPE)

2. Install sealing rubber while pushing it in with fingers.

CAUTION:

Be careful not to twist sealing rubber.

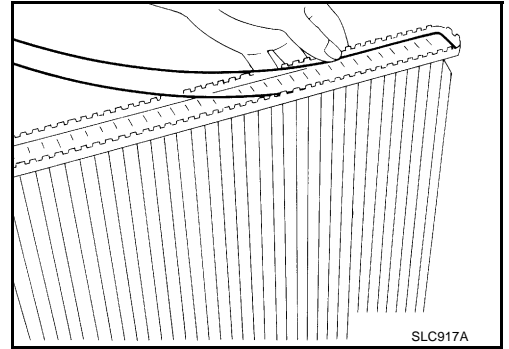

3. Caulk tank in numerical order as shown in the figure with radiator plate pliers A (special service tool).

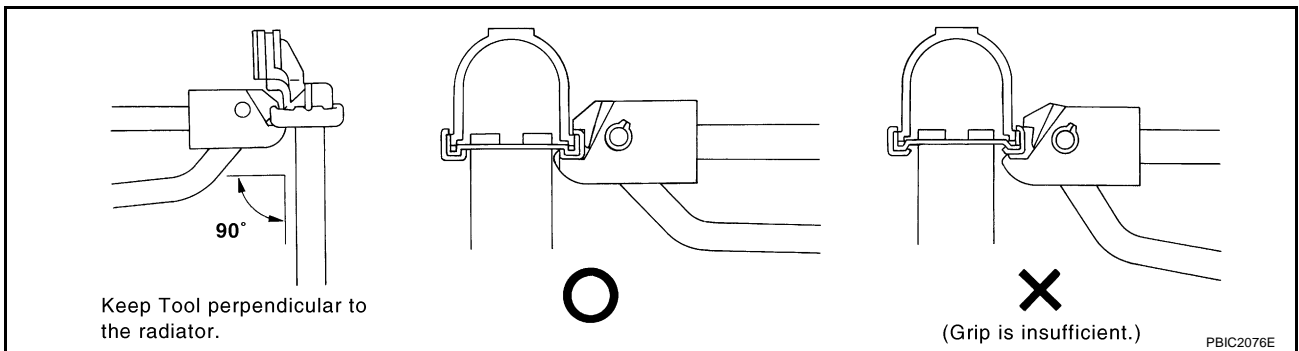
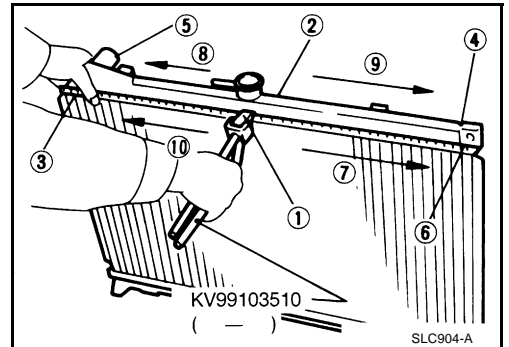

- Use pliers in the locations where radiator plate pliers A cannot be used.

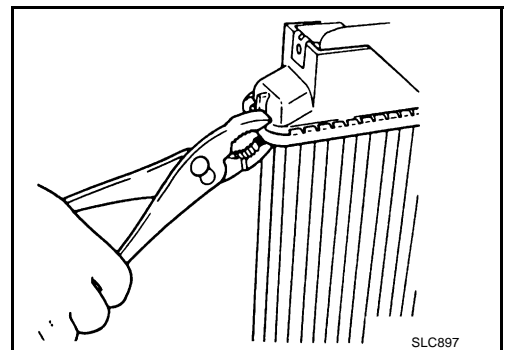

RADIATOR (ALUMINUM TYPE)

4. Make sure that the rim is completely crimped down.

Standard height "H" : 8.0 - 8.4 mm (0.315 - 0.331 in)

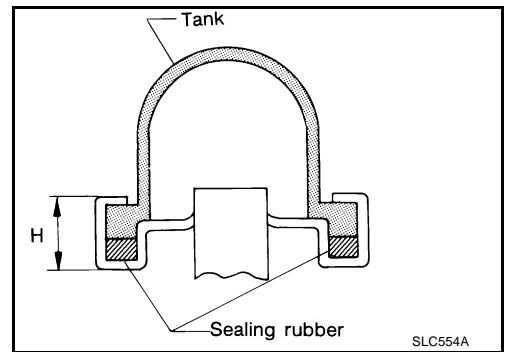

5. Make sure that there is no leakage.
Refer to [CO-19, "INSPECTION"](#).

INSPECTION

1. Apply pressure with radiator cap tester adapter (special service tool) and radiator cap tester (commercial service tool).

Testing pressure

: 157 kPa (1.6 kg/cm² , 23 psi)

WARNING:

To prevent the risk of hose coming undone while under pressure, securely fasten it down with hose clamp.

CAUTION:

Attach hose to A/T fluid cooler to seal its inlet and outlet.
(A/T models)

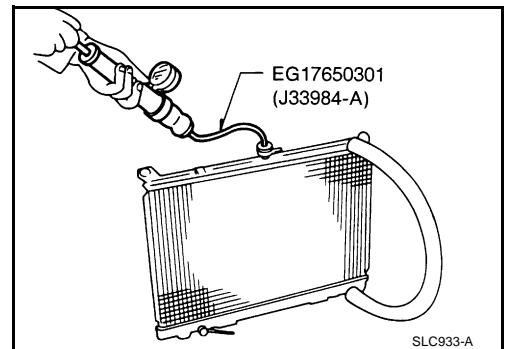

2. Check for leakage by soaking radiator in water container with the testing pressure applied.

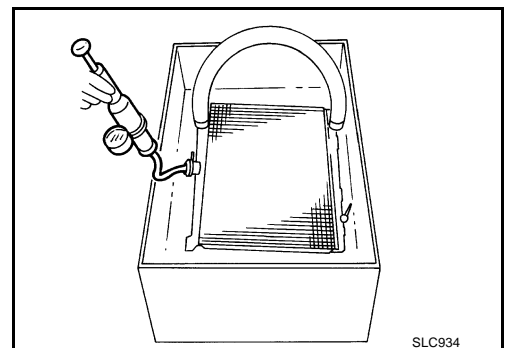

A

CO

C

D

E

F

G

H

I

J

K

L

M

WATER PUMP

PF2:21020

ABS002XY

WATER PUMP

Removal and Installation

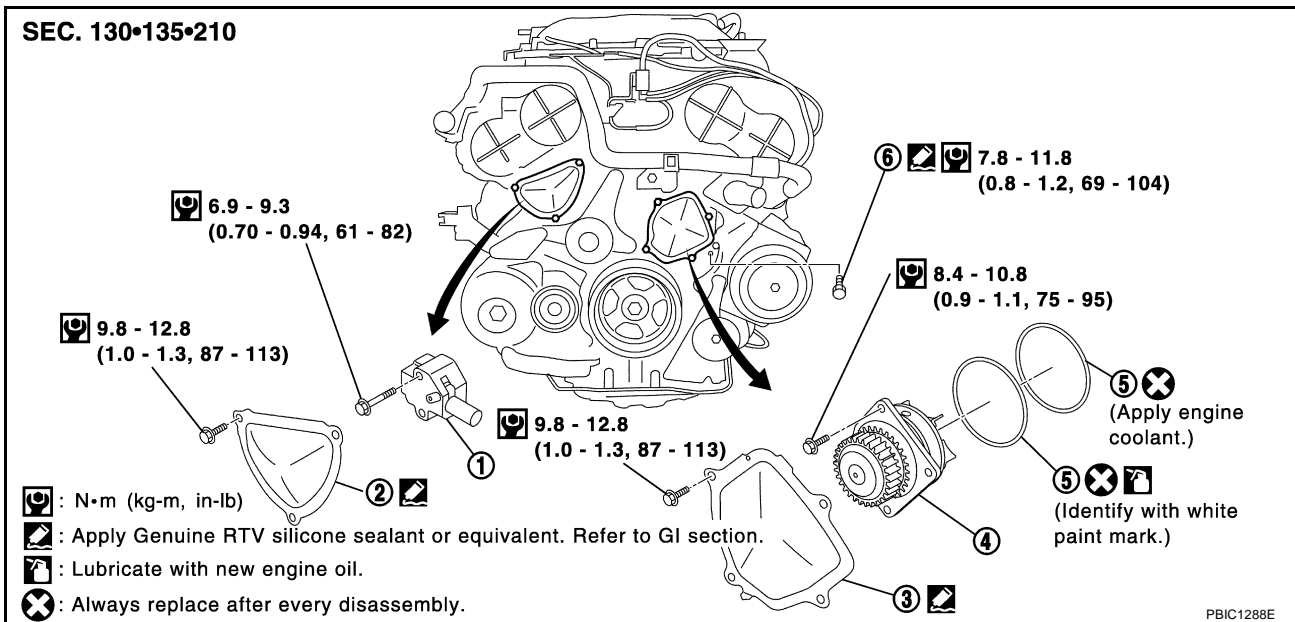

- | | | |
|--------------------|--------------------------|---------------------|
| 1. Chain tensioner | 2. Chain tensioner cover | 3. Water pump cover |
| 4. Water pump | 5. O - rings | 6. Drain plug |

CAUTION:

- When removing water pump assembly, be careful not to get engine coolant on drive belt.
- Water pump cannot be disassembled and should be replaced as a unit.
- After installing water pump, connect hose and clamp securely, then check for leaks using radiator cap tester.

REMOVAL

1. Remove undercover using power tools.
2. Remove drive belts. Refer to [EM-13, "Removal and Installation"](#) .
3. Drain engine coolant from radiator. Refer to [CO-9, "Changing Engine Coolant"](#) .

CAUTION:

Perform when the engine is cold.

4. Remove air duct. Refer to [EM-14, "Removal and Installation"](#) .
5. Remove radiator hoses (upper and lower). Refer to [CO-12, "RADIATOR"](#) .
6. Remove radiator cooling fan assembly. Refer to [CO-12, "RADIATOR"](#) .
7. Remove water drain plug on water pump side of cylinder block.

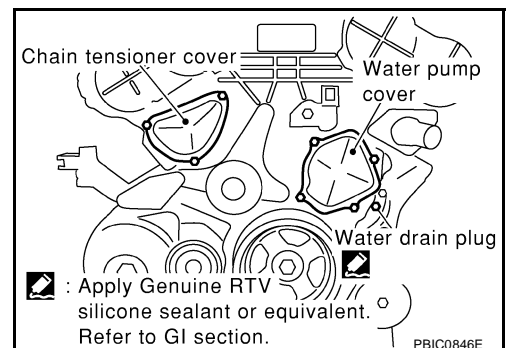

8. Remove chain tensioner cover and water pump cover.
 - Use seal cutter [special service tool: KV10111100 (J37228)] or equivalent tool to cut liquid gasket for remove.
9. Remove the chain tensioner assembly with the following procedure.

WATER PUMP

- a. Pull the lever down and release the plunger stopper tab.
 - Plunger stopper tab can be pushed up to release (coaxial structure with lever).
- b. Insert the stopper pin into the tensioner body hole to hold the lever and keep the stopper tab released.

NOTE:

Allen wrench [2.5 mm (0.098 in)] is used for a stopper pin as an example.

- c. Insert the plunger into the tensioner body by pressing the timing chain slack guide.
- d. Keep the slack guide pressed and hold the plunger in by pushing the stopper pin deeper through the lever and into the tensioner body hole.
- e. Turn crankshaft pulley clockwise so that the timing chain on the chain tensioner side is loose.

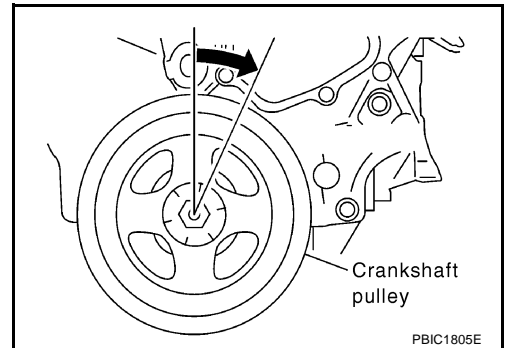
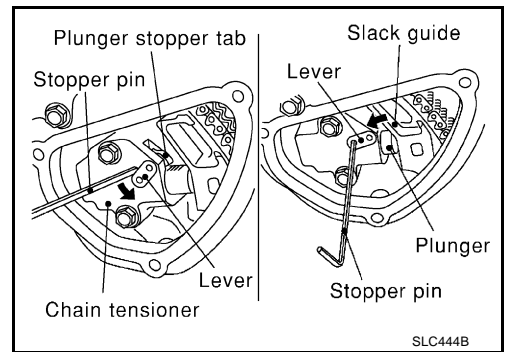

10. Remove chain tensioner.

CAUTION:

Be careful not to drop mounting bolts inside chain case.

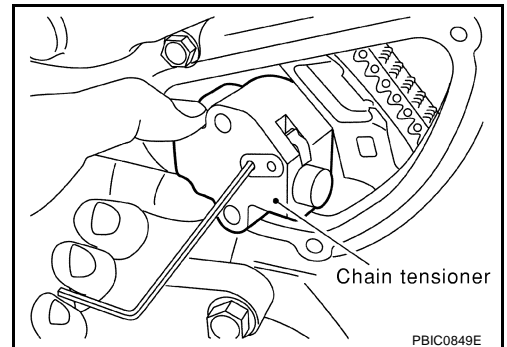

11. Remove three water pump mounting bolts. Secure a gap between water pump gear and timing chain, by turning crankshaft pulley counterclockwise until timing chain looseness on water pump sprocket becomes maximum.

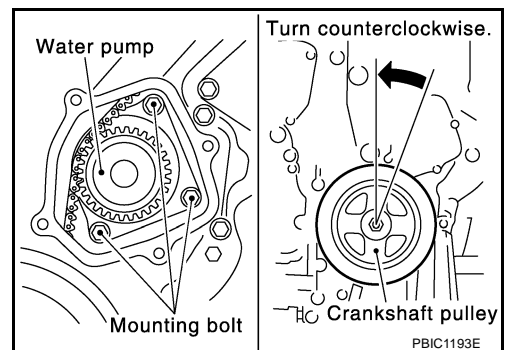

A
CO
C
D
E
F
G
H
I
J
K
L
M

WATER PUMP

12. Screw M8 bolts [pitch: 1.25mm (0.049in) length: Approx. 50 mm (1.97in)] into water pumps upper and lower mounting-bolt holes until they reach timing chain case. Then, alternately tighten each bolt for a half turn, and pull out water pump.
 - Pull straight out while preventing vane from contacting socket in installation area.
 - Remove water pump without causing sprocket to contact timing chain.
13. Remove M8 bolts and O-rings from water pump.

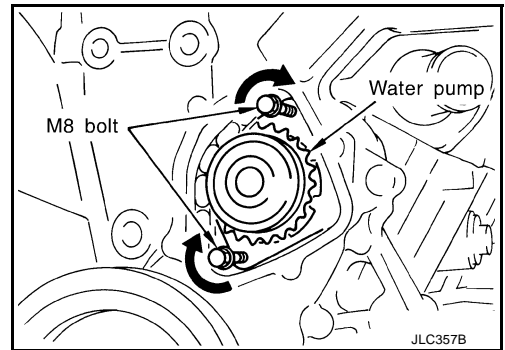

INSPECTION AFTER REMOVAL

1. Check for badly rusted or corroded water pump body assembly.
2. Check for rough operation due to excessive end play.

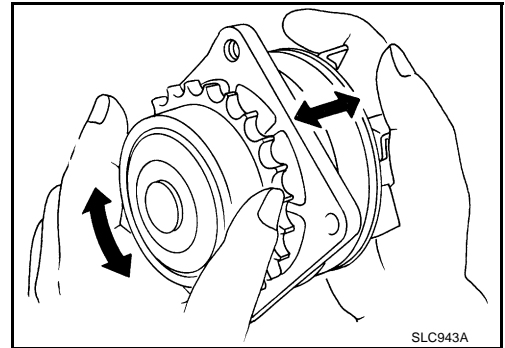

INSTALLATION

1. Install new O-rings to water pump.
2. Apply engine oil and engine coolant to the O-rings as shown.
 - Locate the O-ring with white paint mark to engine front side.

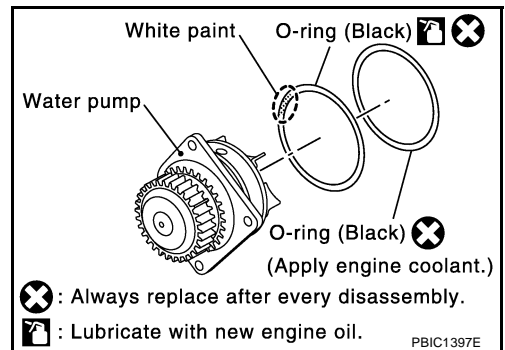

3. Install the water pump.
 - **Do not allow cylinder block to nip the O-rings when installing the water pump.**
 - Check that timing chain and water pump sprocket are engaged.
 - Insert water pump by tightening mounting bolts alternately and evenly.

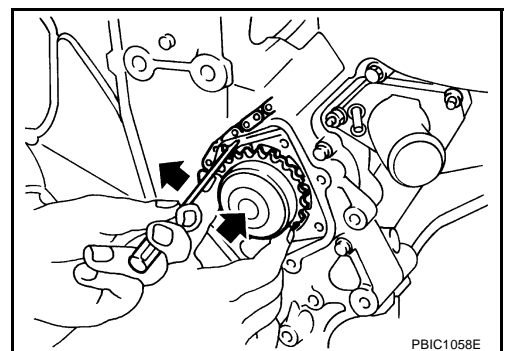

4. Remove dust and foreign material completely from backside of chain tensioner and from installation area of rear timing chain case.
5. Turn the crankshaft pulley clockwise so that the timing chain on the timing chain tensioner side is loose.
 - **When installing the timing chain tensioner, engine oil should be applied to the oil hole and tensioner.**

WATER PUMP

6. Install the timing chain tensioner.
7. Remove the stopper pin.

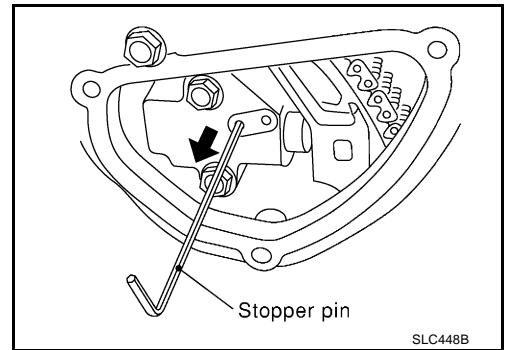

8. Install chain tensioner cover and water pump cover.
 - a. Before installing, remove all traces of liquid gasket from mating surface of water pump cover and chain tensioner cover using a scraper. Also remove traces of liquid gasket from the mating surface of the front cover.

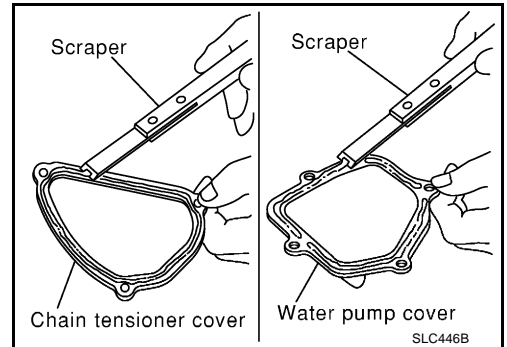

- b. Apply a continuous bead of liquid gasket using tube presser [special service tool: WS39930000 (—)], to mating surface of chain tensioner cover and water pump cover.
Use Genuine RTV Silicone Sealant or equivalent. Refer to [GI-47, "RECOMMENDED CHEMICAL PRODUCTS AND SEALANTS"](#).

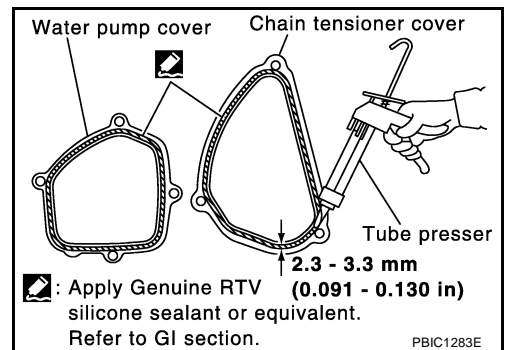

9. Install water drain plug on water pump side of cylinder block.
10. Installation is in the reverse order of removal.
 - **After starting engine, let idle for three minutes, then rev engine up to 3,000 rpm under no load to purge air from the high-pressure chamber of the chain tensioner. The engine may produce a rattling noise. This indicates that air still remains in the chamber and is not a matter of concern.**

THERMOSTAT AND THERMOSTAT HOUSING

THERMOSTAT AND THERMOSTAT HOUSING

PFP:21200

Removal and Installation

ABS002XZ

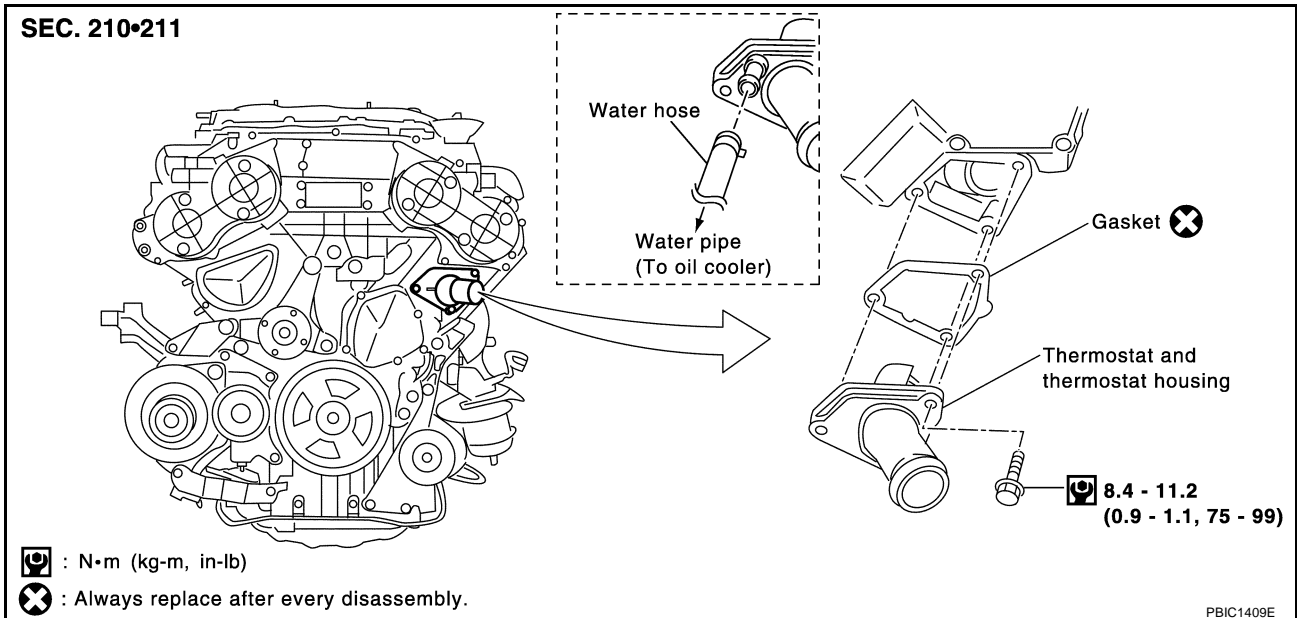

REMOVAL

1. Remove undercover using power tools.
2. Drain engine coolant from the radiator. Refer to [CO-9, "Changing Engine Coolant"](#).

CAUTION:

- Perform this step when engine is cold.
 - Do not spill engine coolant on drive belts.
3. Remove air duct. Refer to [EM-14, "Removal and Installation"](#).
 4. Remove water drain plug on water pump side of the engine.
 5. Remove radiator lower hose from thermostat and thermostat housing.
 6. Remove oil cooler water hose from thermostat and thermostat housing.
 7. Remove thermostat and thermostat housing.
- Do not disassemble thermostat and thermostat housing. Replace them as a unit, if necessary.

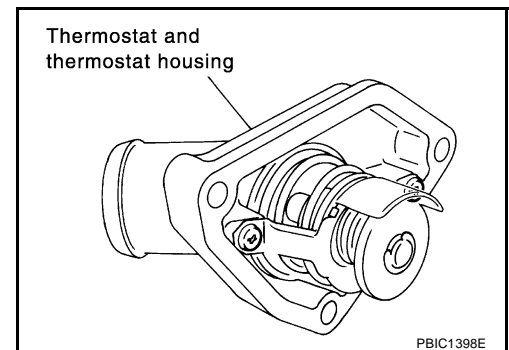

INSPECTION AFTER REMOVAL

1. Check valve seating condition at ordinary room temperatures. It should seat tightly.

THERMOSTAT AND THERMOSTAT HOUSING

2. Check valve opening temperature and maximum valve lift.

Thermostat	Standard
Valve opening temperature	76.5°C (170°F)
Valve lift	8.6 mm / 90°C (0.339 in / 194°F)

3. Then check if valve closes at 5°C (9°F) below valve opening temperature.

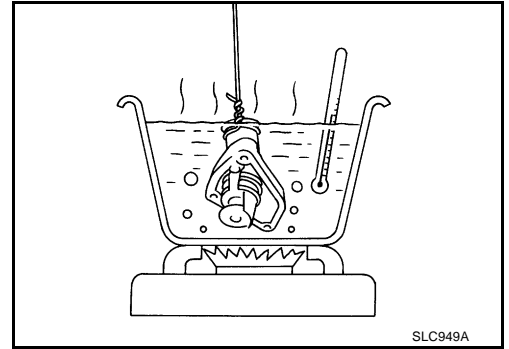

A
CO
C
D
E
F
G
H
I
J
K
L
M

INSTALLATION

Install in the reverse order of removal.

WATER OUTLET AND WATER PIPING

PFP:11060

WATER OUTLET AND WATER PIPING

Removal and Installation

ABS002Y0

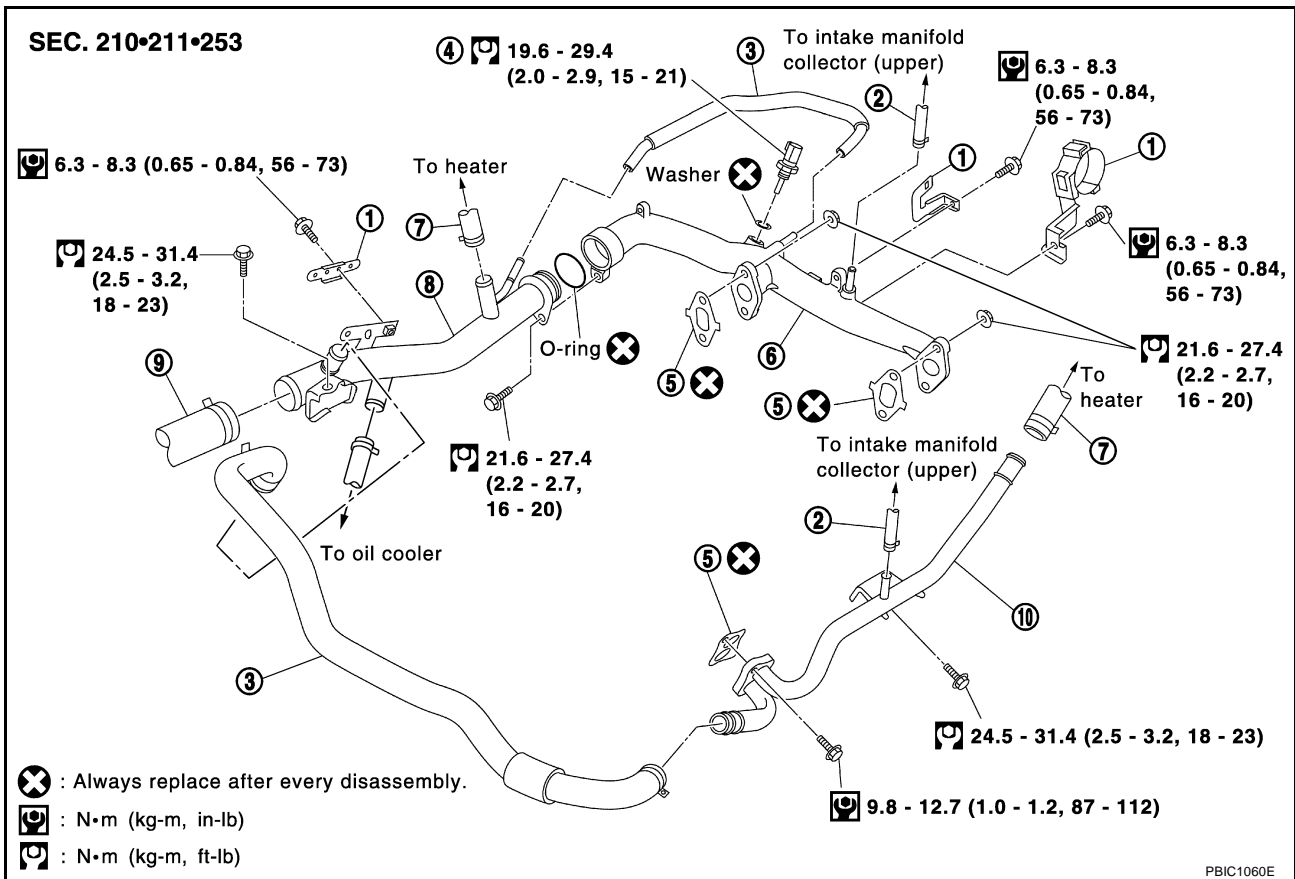

- | | | |
|--------------------------------------|---------------|------------------------|
| 1. Harness bracket | 2. Water hose | 3. Water bypass hose |
| 4. Engine coolant temperature sensor | 5. Gasket | 6. Water outlet |
| 7. Heater hose | 8. Water pipe | 9. Radiator upper hose |
| 10. Heater pipe | | |

REMOVAL

1. Remove undercover using power tools.
2. Drain engine coolant from drain plugs on radiator and both sides of cylinder block. Refer to [CO-9, "Changing Engine Coolant"](#).

CAUTION:

- Perform this step when engine is cold.
- Do not spill engine coolant on drive belts.

3. Remove engine cover. Refer to [EM-16, "REMOVAL"](#).
4. Remove air duct and air cleaner case. Refer to [EM-14, "Removal and Installation"](#).
5. Remove radiator upper hose and heater hose.
6. Remove the following parts, when remove water outlet.
 - A/T fluid charging pipe (A/T models); Refer to [AT-308, "TRANSMISSION ASSEMBLY"](#).
 - Intake manifold collectors (upper and lower). Refer to [EM-16, "INTAKE MANIFOLD COLLECTOR"](#).
 - Rocker cover (right bank). Refer to [EM-39, "ROCKER COVER"](#).

INSTALLATION

1. Install in the reverse order of removal.
2. Securely insert each hose, and install a clamp at a position where it does not interfere with the pipe bulge.
3. When inserting a water pipe into water outlet, apply neutral detergent to O-ring.

SERVICE DATA AND SPECIFICATIONS (SDS)

SERVICE DATA AND SPECIFICATIONS (SDS)

PPF:00100

Capacity

ABS002Y1

Engine coolant capacity (With reservoir tank at MAX level)	8.7 ℓ (9-1/4 US qt, 7- 5/8 Imp qt)
Reservoir tank engine coolant capacity (at MAX level)	0.8 ℓ (7/8 US qt, 3/4 Imp qt)

Thermostat

ABS002Y2

Valve opening temperature	76.5°C (170°F)
Valve lift	8.6 mm / 90°C (0.339 in / 194°F)

Radiator

ABS002Y3

Unit: kPa (kg/cm² , psi)

Cap relief pressure	Standard	78 - 98 (0.8 - 1.0, 11 - 14)
	Limit	59 (0.6, 9)
Leakage test pressure		157 (1.6, 23)

Tightening Torque

ABS002Y4

Unit: N-m (kg-m, ft-lb)
Unit: N-m (kg-m, in-lb)*

Air relief plug	0.78 - 1.6 (0.08 - 0.16, 7 - 14)*
Radiator drain plug	1.2 (0.12, 11)*
Reservoir tank	4.2 (0.43, 37)*
Fan shroud	3.8 - 4.5 (0.39 - 0.45, 34 - 39)*
Cooling fan	2.9 - 3.9 (0.3 - 0.4, 26 - 34)*
Fan motor	3.9 - 4.9 (0.4 - 0.5, 35 - 43)*
Water pump	8.4 - 10.8 (0.9 - 1.1, 75 - 95)*
Water pump cover	9.8 - 12.8 (1.0 - 1.3, 87 - 113)
Chain tensioner cover	9.8 - 12.8 (1.0 - 1.3, 87 - 113)
Chain tensioner	6.9 - 9.3 (0.70 - 0.94, 61 - 82)*
Water outlet	21.6 - 27.4 (2.2 - 2.7, 16 - 20)
Thermostat and thermostat housing	8.4 - 11.2 (0.9 - 1.1, 75 - 99)*
Engine coolant temperature sensor	19.6 - 29.4 (2.0 - 2.9, 15 - 21)

SERVICE DATA AND SPECIFICATIONS (SDS)
