

REAR AXLE & REAR SUSPENSION

SECTION
RA

GI

MA

EM

LC

EC

CONTENTS

PRECAUTIONS AND PREPARATION 2		
Precautions..... 2		
Special Service Tools..... 2		
Commercial Service Tools..... 2		
REAR AXLE AND REAR SUSPENSION 3		
ON-VEHICLE SERVICE 4		
Rear Axle and Rear Suspension Parts..... 4	Wheel Hub..... 6	FE
Rear Wheel Bearing..... 4	REAR SUSPENSION 7	
Rear Wheel Alignment..... 4	Removal and Installation..... 8	CL
REAR AXLE 6	Coil Spring and Strut Assembly..... 8	
	Stabilizer Bar..... 9	MT
	SERVICE DATA AND SPECIFICATIONS (SDS) 10	
	General Specifications..... 10	AT
	Inspection and Adjustment..... 10	

FE

CL

MT

AT

FA

RA

BR

ST

BF

HA

EL

IDX

PRECAUTIONS AND PREPARATION

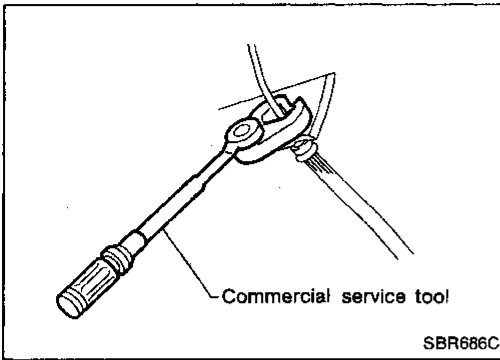

Precautions

- When installing rubber parts, final tightening must be carried out under unladen condition* with tires on ground.
- *: Fuel, radiator coolant and engine oil full. Spare tire, jack, hand tools and mats in designated positions.
- Use flare nut wrench when removing or installing brake tubes.
- After installing removed suspension parts, check wheel alignment and adjust if necessary.
- Do not jack up at the parallel links.
- Always torque brake lines when installing.

Special Service Tools

Tool number (Kent-Moore No.) Tool name	Description	
HT71780000 (—) Spring compressor	 NT144	Removing and installing coil spring
ST35652000 (—) Strut attachment	 NT145	Fixing strut assembly

Commercial Service Tools

Tool name	Description	
① Flare nut crows foot ② Torque wrench	 NT223	Removing and installing each brake piping

REAR AXLE AND REAR SUSPENSION

When installing each rubber part, final tightening must be carried out under unladen condition* with tires on ground.

- * Fuel, radiator coolant and engine oil full.
- Spare tire, jack, hand tools and mats in designated positions.

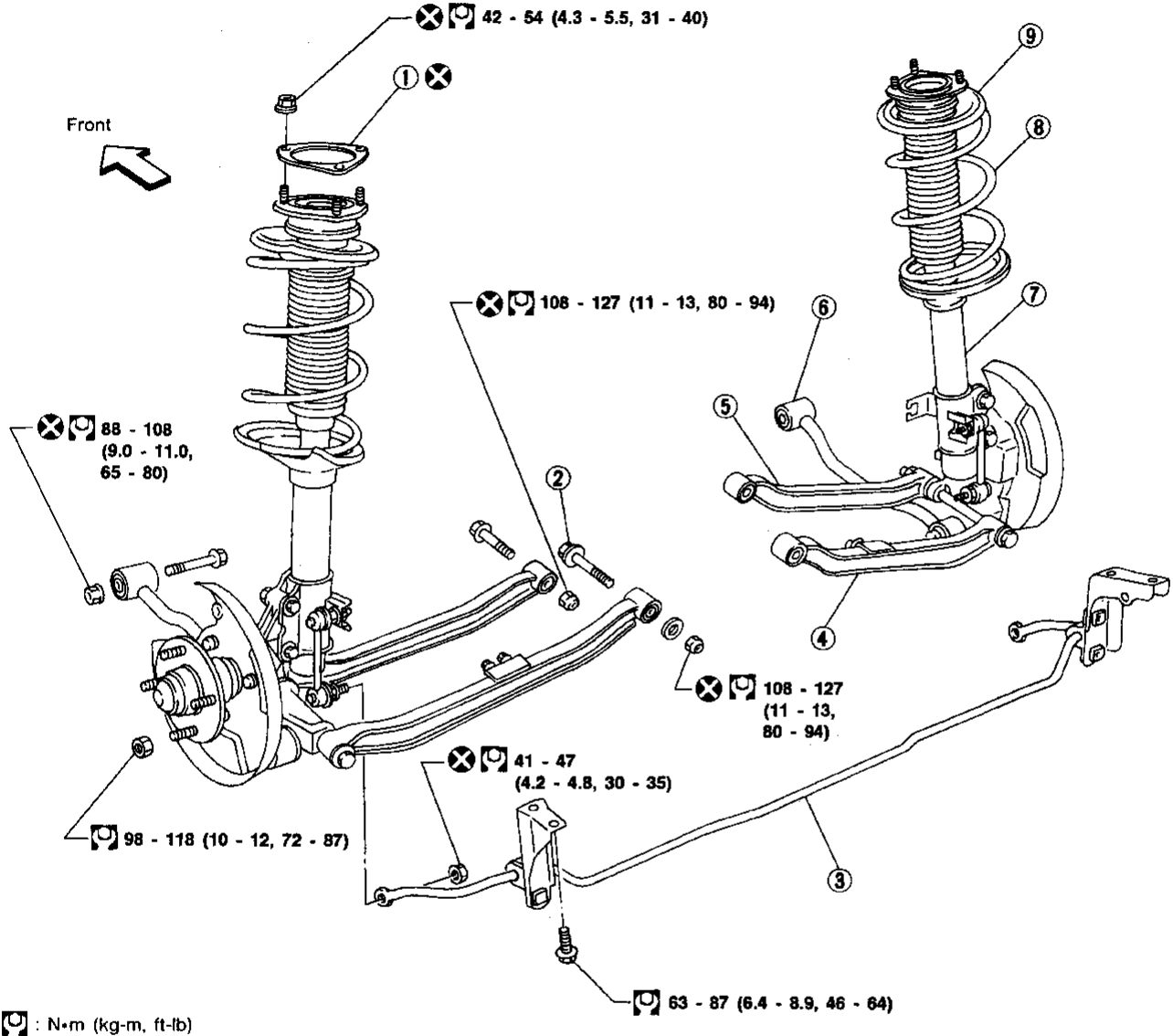

: N·m (kg·m, ft·lb)

- | | | |
|------------------|-----------------------|-------------------------------------|
| ① Gasket | ④ Rear parallel link | ⑦ Strut assembly |
| ② Adjusting bolt | ⑤ Front parallel link | ⑧ Coil spring |
| ③ Stabilizer bar | ⑥ Radius rod | ⑨ Strut mounting insulator assembly |

SRA670A

GI
MA
EM
LC
EC
FE
CL
MT
AT
FA
RA
BR
ST
BF
HA
EL
DX

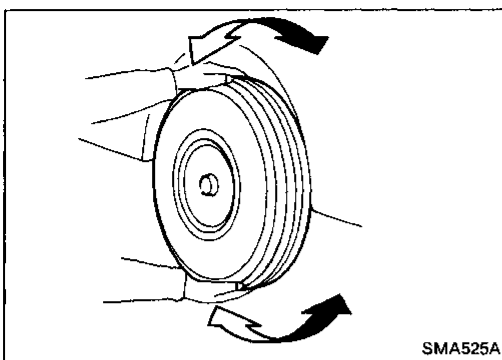

Rear Axle and Rear Suspension Parts

Check axle and suspension parts for looseness, wear or damage.

- Shake each rear wheel to see excessive play.
- Retighten all nuts and bolts to the specified torque.
Tightening torque: Refer to REAR SUSPENSION (RA-7).
- Check strut (shock absorber) for oil leakage or other damage.
- Check wheelarch height. Refer to ON-VEHICLE SERVICE in FA section.

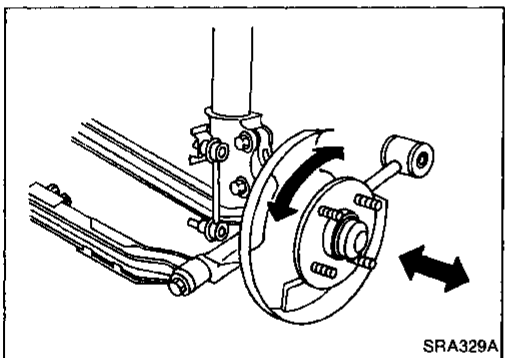
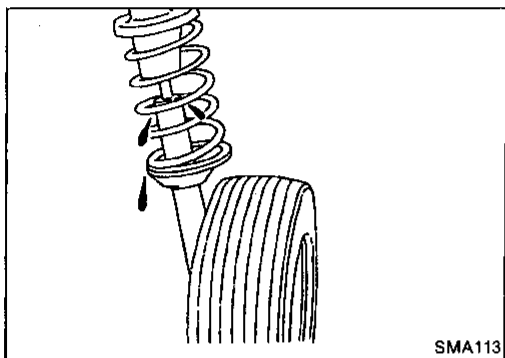

Rear Wheel Bearing

- Check axial end play.
Axial end play:
0.05 mm (0.0020 in) or less
- Check that wheel bearings operate smoothly.
- Check tightening torque of wheel bearing lock nut.
☞: 186 - 255 N·m
(19 - 26 kg·m, 137 - 188 ft·lb)
- Replace wheel bearing assembly if there is axial end play or wheel bearing does not turn smoothly. Refer to REAR AXLE — Wheel Hub (RA-6).

Rear Wheel Alignment

PRELIMINARY INSPECTION

Make following checks. Adjust, repair or replace if necessary.

- Check tires for wear and for improper inflation.
- Check rear wheel bearings for looseness.
- Check wheel runout.
Wheel runout: Refer to SDS in FA section.
- Check that rear strut (shock absorber) works properly.
- Check rear axle and rear suspension parts for looseness.
- Check vehicle posture (Unladen*).

*: Fuel, radiator and engine oil full. Spare tire, jack, hand tools and mats in designated positions.

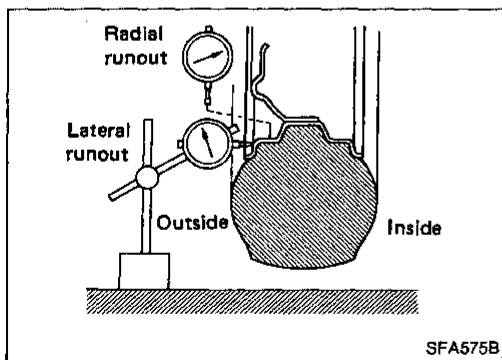

CAMBER

Camber is preset at factory and cannot be adjusted.

Camber:

Refer to SDS (RA-10).

- If the camber is not within specification, inspect and replace any damaged or worn rear suspension parts.

ON-VEHICLE SERVICE

Rear Wheel Alignment (Cont'd)

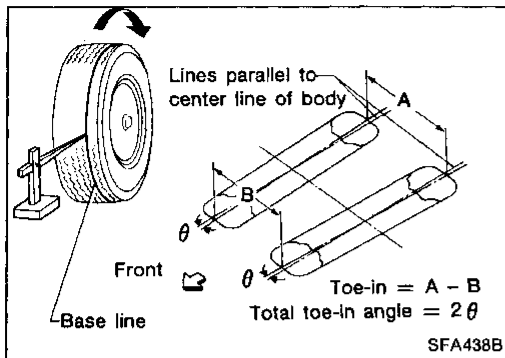

TOE-IN

1. Draw a base line across the tread.
 - After lowering rear of vehicle, move it up and down to eliminate friction.
2. Measure toe-in.
 - Measure distance "A" and "B" at the same height as hub center.

Toe-in:

Refer to SDS (RA-10).

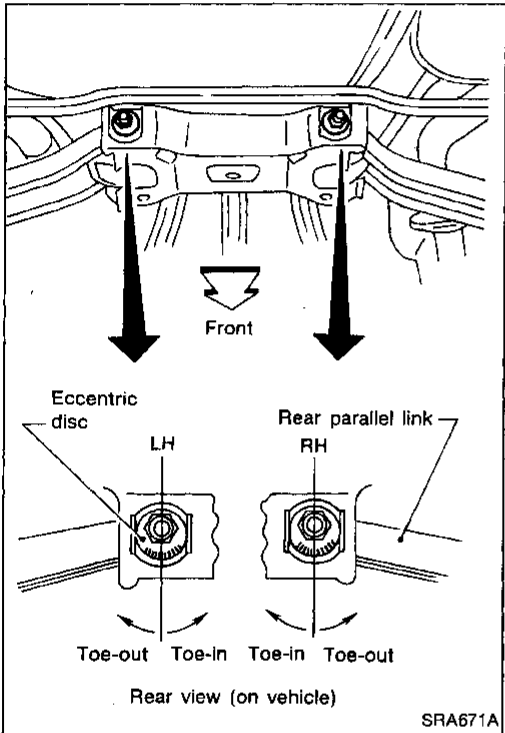

3. Loosen adjusting bolt fixing nuts.
4. Adjust toe-in by turning adjusting bolts.

Toe changes about 2.0 mm (0.079 in) [One side] with each graduation of the adjusting bolt.

5. Tighten adjusting bolt fixing nuts to the specified torque.

**Ⓜ: 108 - 127 N·m
(11 - 13 kg·m, 80 - 94 ft-lb)**

GI

MA

EM

LC

EC

FE

CL

MT

AT

FA

RA

BR

ST

BF

HA

EL

IDX

REAR AXLE

Wheel Hub

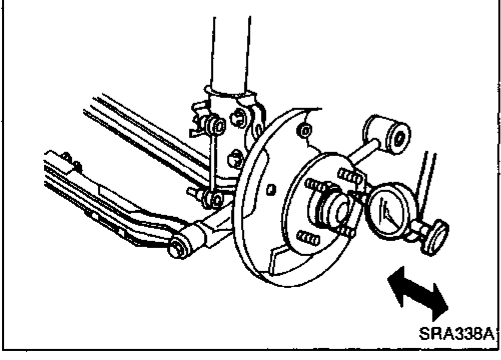
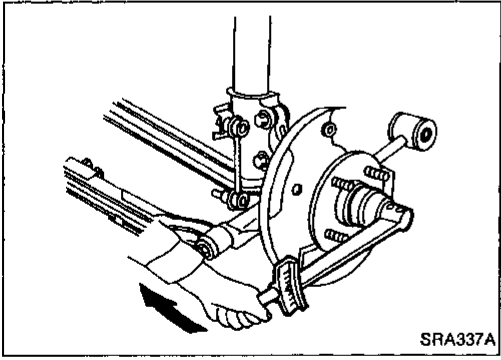
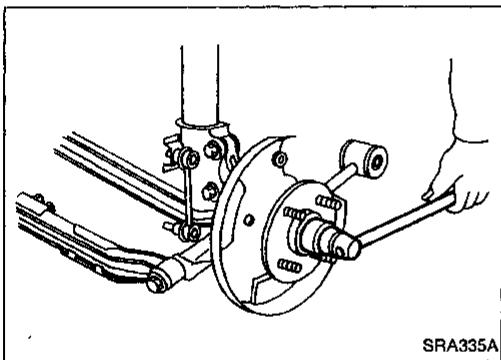
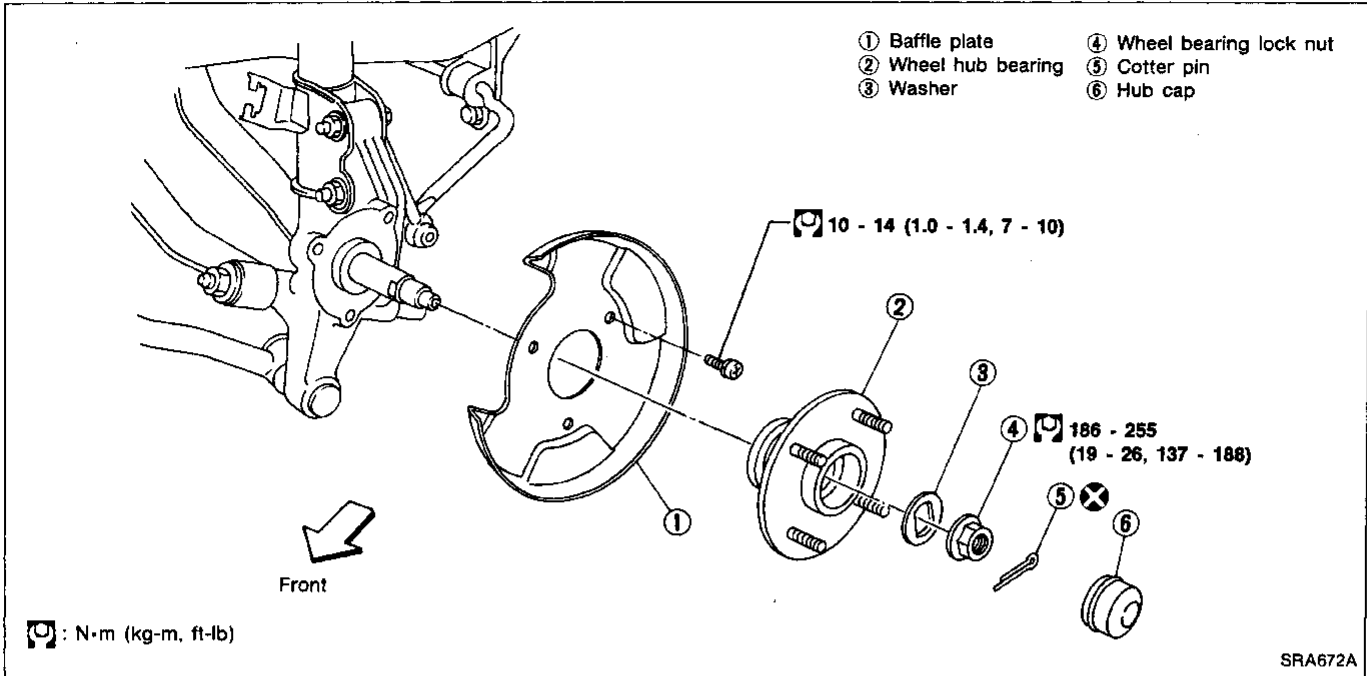

REMOVAL

CAUTION:

- Before removing the rear wheel hub assembly, disconnect the ABS wheel sensor from the assembly. Then move it away from the hub assembly. Failure to do so may result in damage to the sensor wires and the sensor becoming inoperative.
- Wheel hub bearing usually does not require maintenance. If any of the following symptoms are noted, replace wheel hub bearing assembly.
 - Growling noise is emitted from wheel hub bearing during operation.
 - Wheel hub bearing drags or turns roughly. This occurs when turning hub by hand after bearing lock nut is tightened to specified torque.
 - If the wheel hub bearing assembly is removed, it must be renewed. The old assembly must not be re-used.

1. Remove brake caliper assembly and rotor.
 In this case, suspend caliper assembly with wire so as not to stretch brake hose.

Be careful not to depress brake pedal, or piston will pop out. Make sure brake hose is not twisted.

2. Remove wheel bearing lock nut.

INSTALLATION

- Install wheel hub bearing.
- Tighten wheel bearing lock nut.
 Before tightening, apply oil to threaded portion of rear spindle and both sides of plain washer.
- : 186 - 255 N·m (19 - 26 kg-m, 137 - 188 ft-lb)
- Check that wheel bearings operate smoothly.
- Check wheel bearing axial end play.
 Axial end play:
 0.05 mm (0.0020 in) or less

REAR SUSPENSION

When installing rubber parts, final tightening must be carried out under unladen condition* with tires on ground.

* Fuel, radiator coolant and engine oil full.

Spare tire, jack, hand tools and mats in designated positions.

Do not jack up at the parallel links, radius rods.

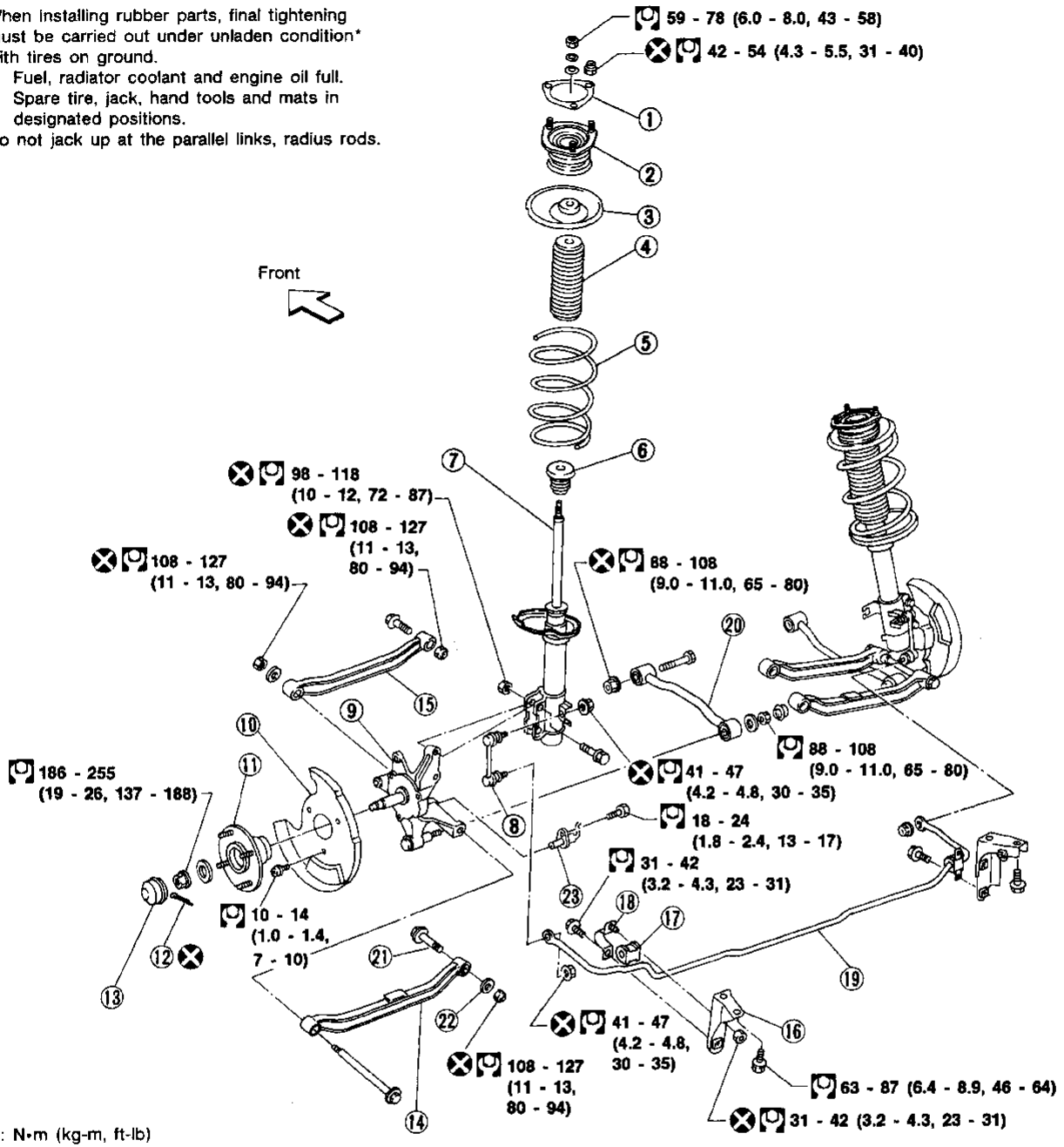

- | | | |
|----------------------------|-----------------------|------------------|
| ① Gasket | ⑨ Knuckle assembly | ⑰ Bushing |
| ② Strut mounting insulator | ⑩ Baffle plate | ⑱ Clamp |
| ③ Upper spring seat | ⑪ Wheel hub bearing | ⑲ Stabilizer bar |
| ④ Dust cover | ⑫ Cotter pin | ⑳ Radius rod |
| ⑤ Coil spring | ⑬ Hub cap | ㉑ Adjusting bolt |
| ⑥ Bound bumper | ⑭ Rear parallel link | ㉒ Eccentric disc |
| ⑦ Strut assembly | ⑮ Front parallel link | ㉓ ABS sensor |
| ⑧ Connecting rod | ⑯ Mounting bracket | |

SRA673A

GI
MA
EM
LC
EC
FE
CL
MT
AT
FA
RA
BR
ST
BF
HA
EL
IDX

Removal and Installation

CAUTION:

Do not jack up at the parallel links or radius rods.

- Remove suspension assembly.
- 1. Remove brake caliper assembly and rotor.
- 2. Remove parallel link fixing bolt, radius rod fixing bolt, stabilizer fixing bolt and stabilizer connecting rod.
- 3. Remove rear seat and finisher. Refer to BF section.
- 4. Remove strut securing nuts (Upper side). Then pull out strut assembly.

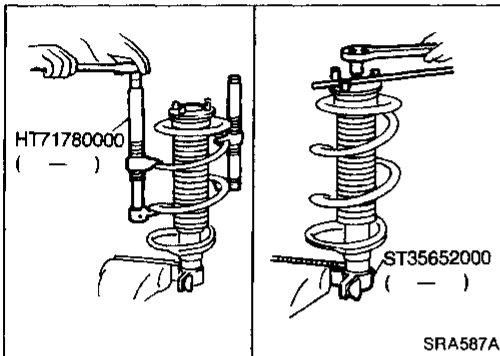

Coil Spring and Strut Assembly

DISASSEMBLY

1. Set strut assembly in vise with attachment, then loosen piston rod lock nut.

Do not remove piston rod lock nut.

2. Compress spring with Tool so that the strut mounting insulator can be turned by hand.

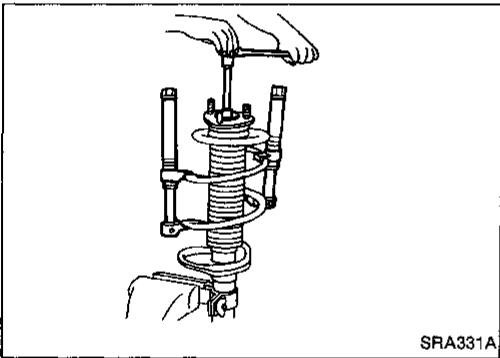

3. Remove piston rod lock nut.
4. Remove spring, complete with Tool.

INSPECTION

Strut assembly

- Check for smooth operation through a full stroke, both compression and extension.
- Check for oil leakage occurring on welded or gland packing portions.
- Check piston rod for cracks, deformation or other damage. Replace if necessary.

Spring rubber seat and dust cover

Check rubber parts for deterioration or cracks. Replace if necessary.

Strut mounting insulator

- Check cemented rubber-to-metal portion for melting or cracks.
- Check rubber parts for deterioration.

Coil spring

Check for cracks, deformation or other damage. Replace if necessary.

REAR SUSPENSION

Coil Spring and Strut Assembly (Cont'd)

ASSEMBLY

1. Locate upper spring seat as shown.

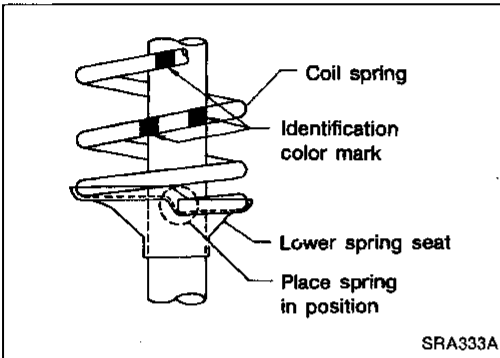
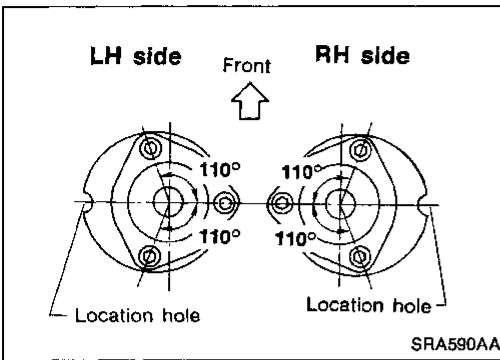

2. When installing coil spring on strut, there must be 2 identification color marks on the lower side.
3. After placing coil spring in position on lower spring seat, tighten lock nut. Then gradually release spring compressor.

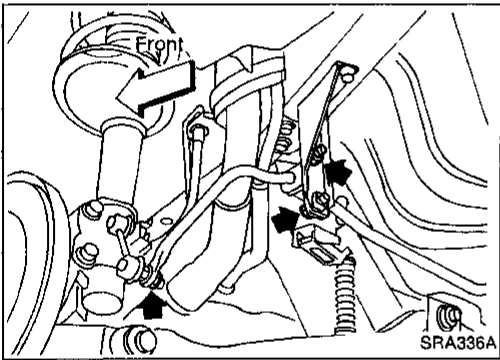

Stabilizer Bar

REMOVAL AND INSTALLATION

- Remove stabilizer bar.

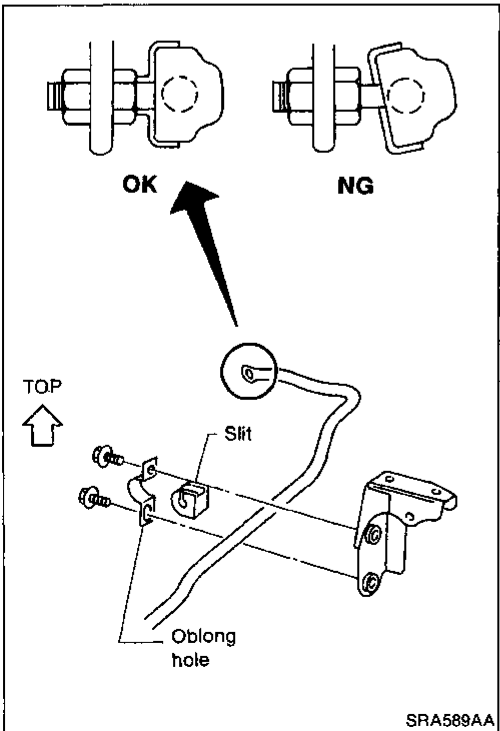

- When installing stabilizer bar, it must be positioned as shown.
- Install stabilizer bar with ball joint socket properly placed.

SERVICE DATA AND SPECIFICATIONS (SDS)

General Specifications

COIL SPRING

Wire diameter	mm (in)	12.3 (0.484)
Coil diameter (average)	mm (in)	150.3 (5.92)
Free length	mm (in)	317.5 (12.50)
Spring constant	N/mm (kg/mm, lb/in)	19.6 (2.0, 112)
Identification color		Yellow x 2, Red x 1

SHOCK ABSORBER

Damping force [at 0.3 m (1.0 ft)/sec.]	N (kg, lb)	
Expansion		667 - 902 (88 - 92, 150 - 203)
Compression		265 - 422 (27 - 43, 60 - 95)
Piston rod diameter	mm (in)	22 (0.87)

REAR STABILIZER BAR

Applied model		All
Stabilizer bar diameter	mm (in)	16.5 (0.650)
Identification color		Yellow

Inspection and Adjustment

WHEEL ALIGNMENT (Unladen*)

Applied model		All
Camber	degree	-1°50' to -0°20'
Toe-in		
A - B	mm (in)	-1 to 3 (-0.04 to 0.12)
Total angle 2θ	degree	-5' to 15'

WHEEL BEARING

Applied model		All
Wheel bearing axial end play	mm (in)	0.05 (0.0020) or less
Wheel bearing lock nut tightening torque	N·m (kg-m, ft-lb)	186 - 255 (19 - 26, 137 - 188)

* Fuel, radiator coolant and engine oil full.
Spare tire, jack, hand tools and mats in designated positions.