

BRAKE SYSTEM

SECTION **BR**

GI
MA
EM
LC
EC
FE
CL
MT
AT
FA
RA
BR
ST
BF
HA
EL
IDX

CONTENTS

PRECAUTIONS AND PREPARATION	2	Assembly	14
Precautions	2	Installation	14
Commercial Service Tools	2	REAR DISC BRAKE	15
BRAKE HYDRAULIC LINE/CONTROL VALVE	3	Pad Replacement	15
Brake Hydraulic Line	3	Removal	17
Dual Proportioning Valve	4	Disassembly	17
CHECK AND ADJUSTMENT	5	Inspection — Caliper	18
Checking Brake Fluid Level	5	Inspection — Rotor	19
Checking Brake Line	5	Assembly	19
Changing Brake Fluid	5	Installation	20
Bleeding Brake System	5	PARKING BRAKE CONTROL	21
BRAKE PEDAL AND BRACKET	6	Removal and Installation	21
Removal and Installation	6	Inspection	22
Inspection	6	Adjustment	22
Adjustment	6	ANTI-LOCK BRAKE SYSTEM	23
MASTER CYLINDER	7	Purpose	23
Removal	7	Operation	23
Disassembly	7	ABS Hydraulic Circuit	23
Inspection	8	System Components	24
Assembly	8	System Description	24
Installation	8	Removal and Installation	25
BRAKE BOOSTER/VACUUM HOSE	9	Wiring Diagram — ABS —	27
Brake Booster	9	TROUBLE DIAGNOSES	31
Vacuum Hose	10	Contents	31
FRONT DISC BRAKE	11	Component Parts and Harness Connector	
Pad Replacement	11	Location	35
Removal	12	SERVICE DATA AND SPECIFICATIONS (SDS)	54
Disassembly	13	General Specifications	54
Inspection — Caliper	13	Inspection and Adjustment	54
Inspection — Rotor	13		

When you read wiring diagrams:

- Read GI section, "HOW TO READ WIRING DIAGRAMS".
- See EL section, "POWER SUPPLY ROUTING" for power distribution circuit.

When you perform trouble diagnoses, read GI section, "HOW TO FOLLOW FLOW CHART IN TROUBLE DIAGNOSES" and "HOW TO PERFORM EFFICIENT DIAGNOSIS FOR AN ELECTRICAL INCIDENT".

PRECAUTIONS AND PREPARATION

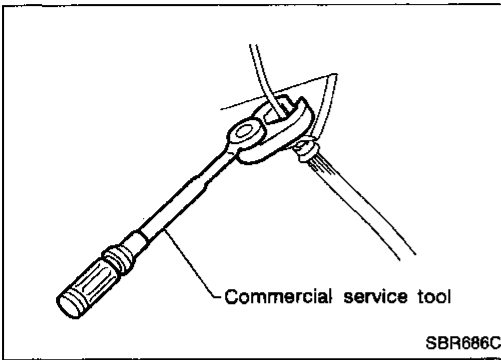

Precautions

- Recommended fluid is brake fluid "DOT 3".
- Never reuse drained brake fluid.
- Be careful not to splash brake fluid on painted areas.
- To clean or wash all parts of master cylinder, disc brake caliper and wheel cylinder, use clean brake fluid.
- Never use mineral oils such as gasoline or kerosene. They will ruin rubber parts of the hydraulic system.
- Use flare nut wrench when removing and installing brake tube.
- Always torque brake lines when installing.

WARNING:

- Clean brake pads and shoes with a waste cloth, then wipe with a dust collector.

Commercial Service Tools

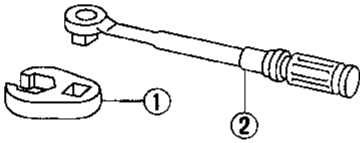
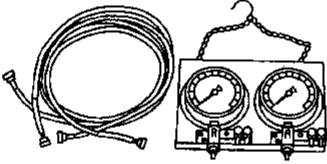
Tool name	Description
<p>① Flare nut crows foot Distance across flats: 10 mm (0.39 in)</p> <p>② Torque wrench</p>	 <p>Removing and installing each brake piping</p> <p>NT223</p>
<p>Brake fluid pressure gauge</p>	 <p>Measuring brake fluid pressure</p> <p>NT151</p>

BRAKE HYDRAULIC LINE/CONTROL VALVE

Brake Hydraulic Line

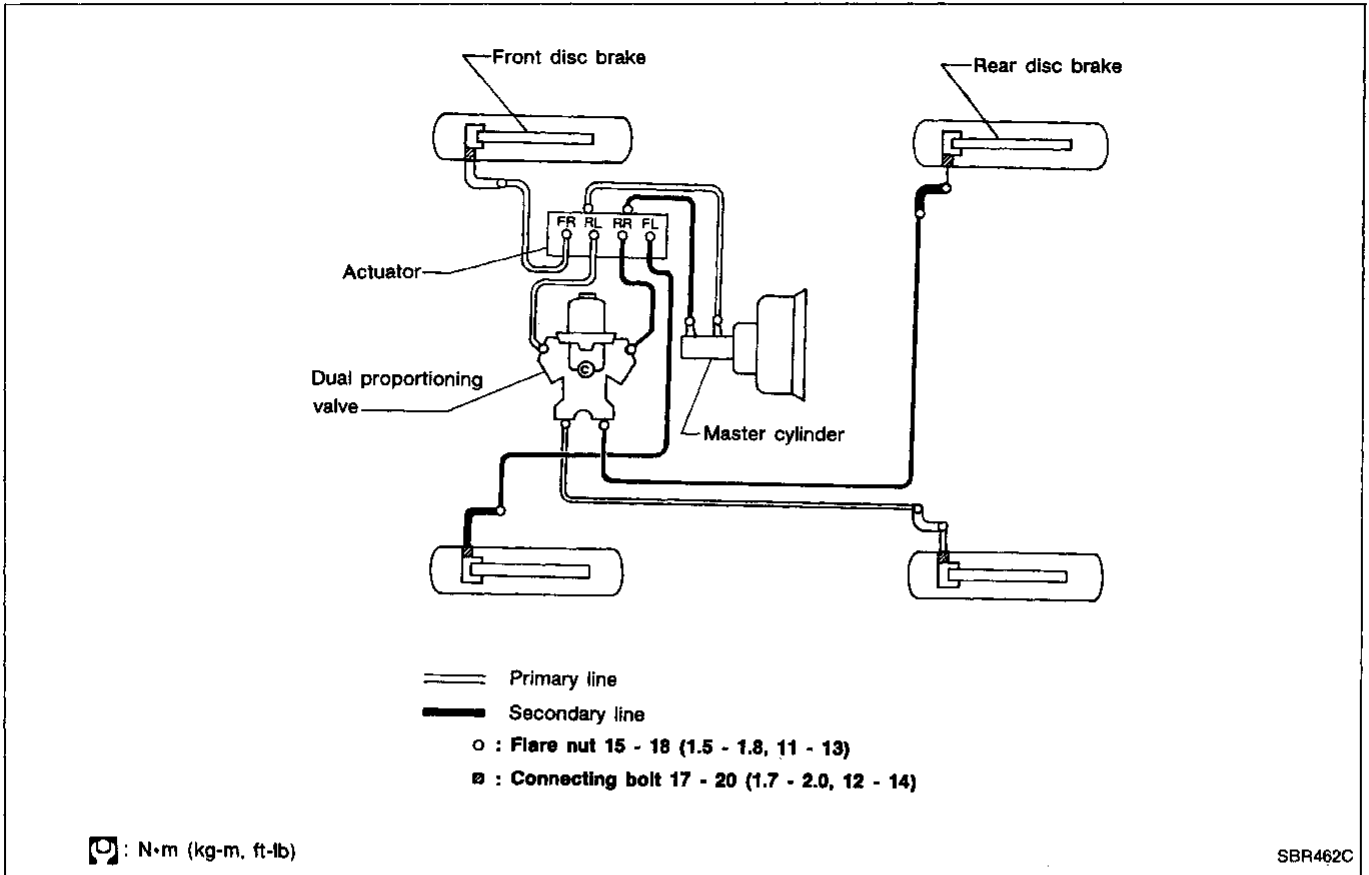

GI
MA
EM
LC
EC
FE
CL
MT
AT
FA
RA

BR

ST

BF

HA

EL

IDX

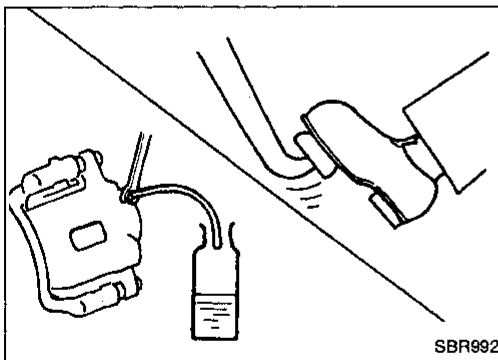

REMOVAL

CAUTION:

- Be careful not to splash brake fluid on painted areas; it may cause paint damage. If brake fluid is splashed on painted areas, wash it away with water immediately.
 - All hoses must be free from excessive bending, twisting and pulling.
1. Connect vinyl tube to air bleeder valve.
 2. Drain brake fluid from each air bleeder valve by depressing brake pedal.
 3. Remove flare nut connecting brake tube and hose, then withdraw lock spring.
 4. Cover openings to prevent entrance of dirt whenever disconnecting brake line.

INSPECTION

Check brake lines (tubes and hoses) for cracks, deterioration or other damage. Replace any damaged parts.

BRAKE HYDRAULIC LINE/CONTROL VALVE

Brake Hydraulic Line (Cont'd)

INSTALLATION

CAUTION:

- Refill with new brake fluid "DOT 3".
 - Never reuse drained brake fluid.
1. Tighten all flare nuts and connecting bolts.

Specification:

Flare nut

15 - 18 N·m (1.5 - 1.8 kg·m, 11 - 13 ft·lb)

Connecting bolt

17 - 20 N·m (1.7 - 2.0 kg·m, 12 - 14 ft·lb)

2. Refill until new brake fluid comes out of each air bleeder valve.
3. Bleed air. Refer to "Bleeding Brake System" (BR-5).

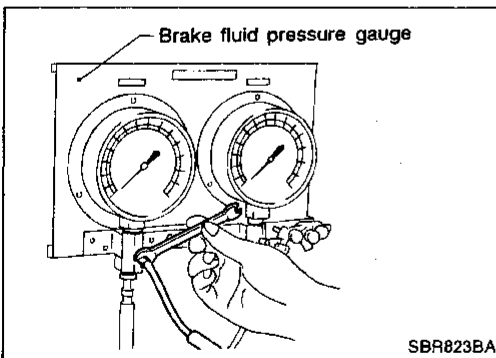
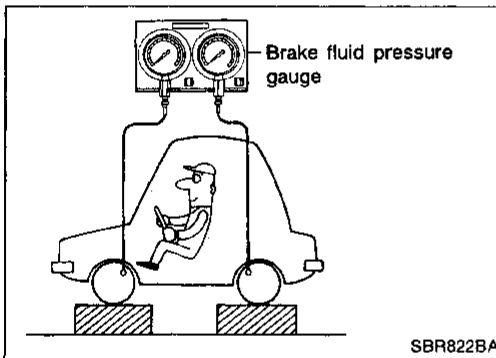
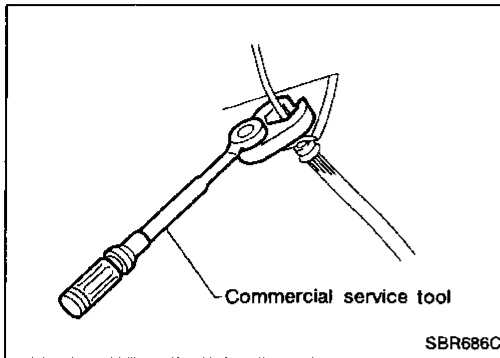

Dual Proportioning Valve

INSPECTION

CAUTION:

- Carefully monitor brake fluid level at master cylinder.
- Use new brake fluid "DOT 3".
- Be careful not to splash brake fluid on painted areas; it may cause paint damage. If brake fluid is splashed on paint areas, wash it away with water immediately.

1. Connect Tool to air bleeders of front and rear brakes on either LH and RH side.
2. Bleed air from the Tool.
3. Check fluid pressure by depressing brake pedal.

Unit: kPa (kg/cm², psi)

Applied pressure (Front brake)	5,884 (60, 853)
Output pressure (Rear brake)	3,629 - 4,021 (37 - 41, 526 - 583)

4. Bleed air after disconnecting the Tool. Refer to "Bleeding Brake System" (BR-5).

CHECK AND ADJUSTMENT

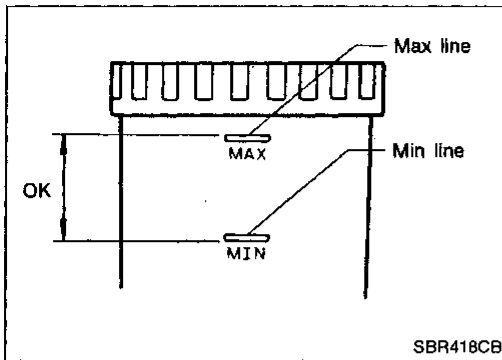

Checking Brake Fluid Level

- Check fluid level in reservoir tank. It should be between Max and Min lines on reservoir tank.
- If fluid level is extremely low, check brake system for leaks.
- Release parking brake lever and see if brake warning lamp goes off. If not, check brake system for leaks.

GI

MA

EM

LC

EC

FE

CL

MT

AT

FA

RA

BR

ST

BF

HA

EL

IDX

Checking Brake Line

CAUTION:

If leakage occurs around joints, retighten or, if necessary, replace damaged parts.

1. Check brake lines (tubes and hoses) for cracks, deterioration or other damage. Replace any damaged parts.
2. Check for oil leakage by fully depressing brake pedal while engine is running.

Changing Brake Fluid

CAUTION:

- Refill with new brake fluid "DOT 3".
- Always keep fluid level higher than minimum line on reservoir tank.
- Never reuse drained brake fluid.
- Be careful not to splash brake fluid on painted areas; it may cause paint damage. If brake fluid is splashed on painted areas, wash it away with water immediately.

1. Clean inside of reservoir tank, and refill with new brake fluid.
2. Connect a vinyl tube to each air bleeder valve.
3. Drain brake fluid from each air bleeder valve by depressing brake pedal.
4. Refill until brake fluid comes out of each air bleeder valve. Use same procedure as in bleeding hydraulic system to refill brake fluid. Refer to "Bleeding Brake System" (BR-5).

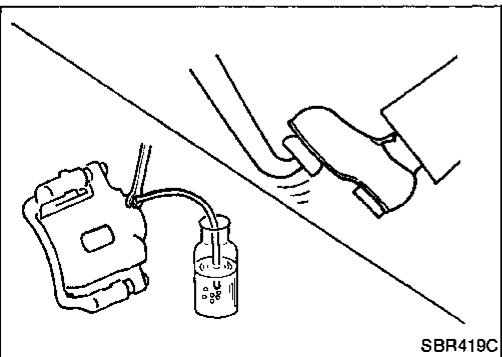
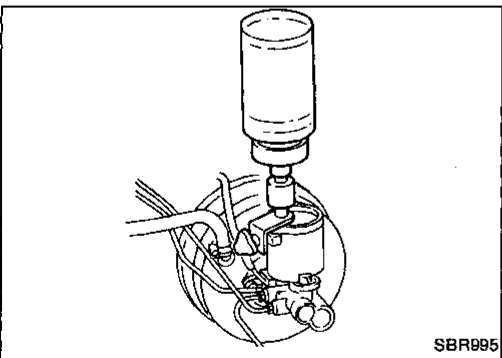
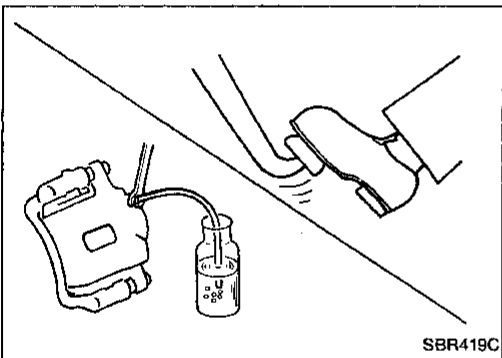
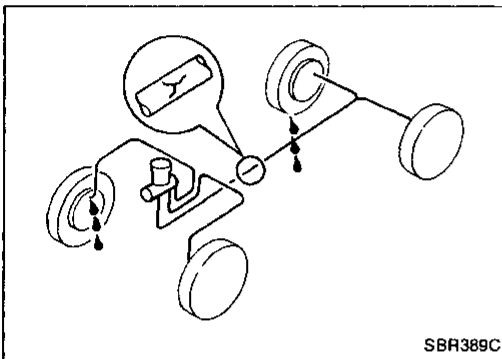

Bleeding Brake System

CAUTION:

- Carefully monitor brake fluid level at master cylinder during bleeding operation.
- Fill reservoir with new brake fluid "DOT 3". Make sure it is full at all times while bleeding air out of system.
- Place a container under master cylinder to avoid spillage of brake fluid.
- For models with ABS, turn ignition switch OFF and disconnect ABS actuator connectors or battery ground cable.

- Bleed air in the following order.
Right rear brake → Left front brake → Left rear brake → Right front brake

1. Connect a transparent vinyl tube to air bleeder valve.
2. Fully depress brake pedal several times.
3. With brake pedal depressed, open air bleeder valve to release air.
4. Close air bleeder valve.
5. Release brake pedal slowly.
6. Repeat steps 2. through 5. until clear brake fluid comes out of air bleeder valve.

BRAKE PEDAL AND BRACKET

Removal and Installation

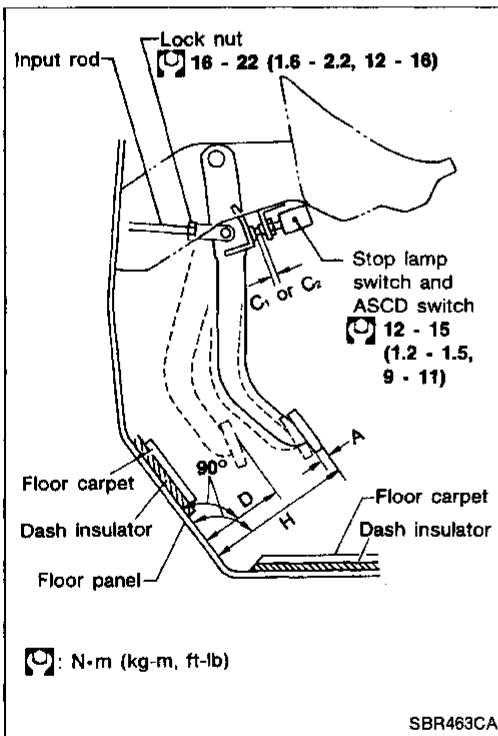
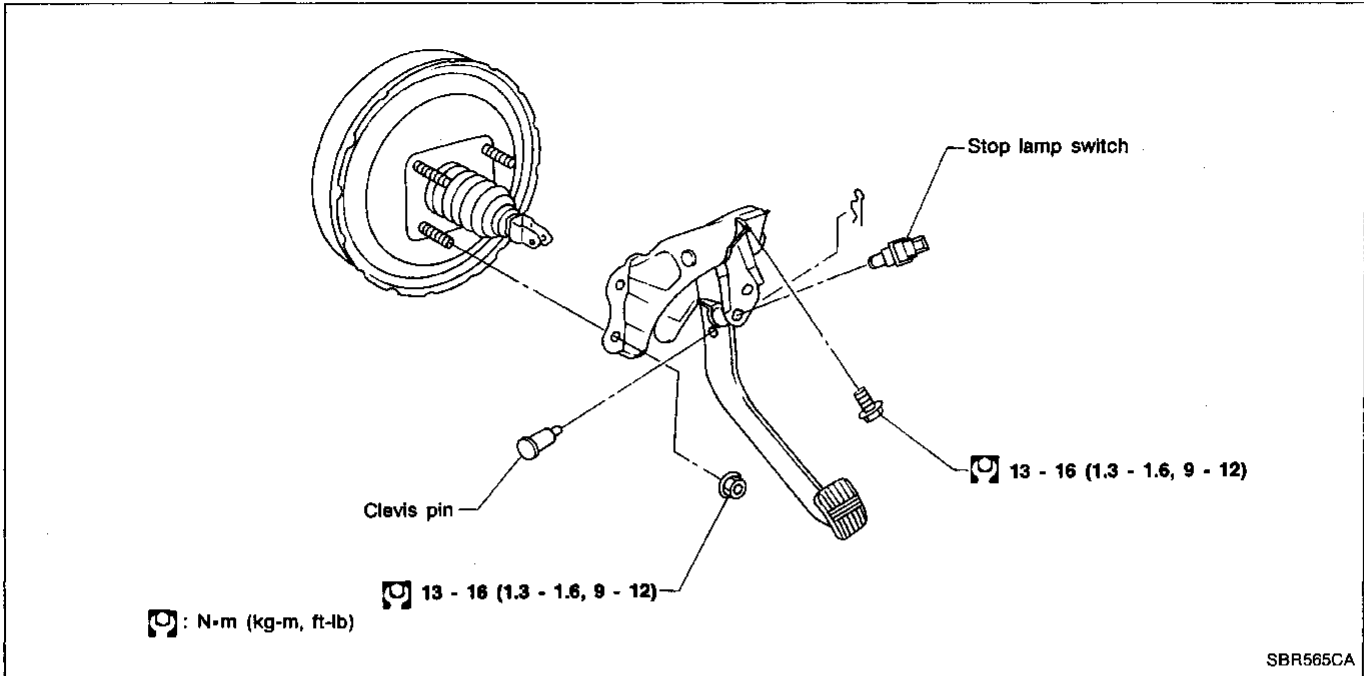

Inspection

Check brake pedal for following items.

- Brake pedal bend
- Clevis pin deformation
- Crack of any welded portion

Adjustment

Check brake pedal free height from dash reinforcement panel. Adjust if necessary.

- H:** Free height
Refer to SDS (BR-54).
- D:** Depressed height
Refer to SDS. (BR-54).
Under force of 490 N (50 kg, 110 lb)
with engine running
- C₁, C₂:** Clearance between pedal stopper and threaded end of stop lamp switch and ASCD switch
0.3 - 1.0 mm (0.012 - 0.039 in)
- A:** Pedal free play
1 - 3 mm (0.04 - 0.12 in)

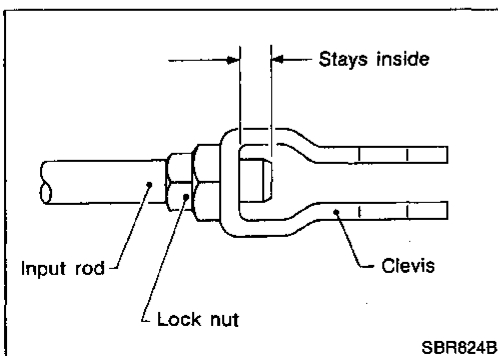

1. Loosen lock nut and adjust pedal free height by turning brake booster input rod. Then tighten lock nut.
2. Check pedal free play.

Make sure that stop lamps go off when pedal is released.

3. Check brake pedal's depressed height while engine is running. If lower than specification, check brake system for leaks, accumulation of air or any damage to components (master cylinder, wheel cylinder, etc.); then make necessary repairs.

MASTER CYLINDER

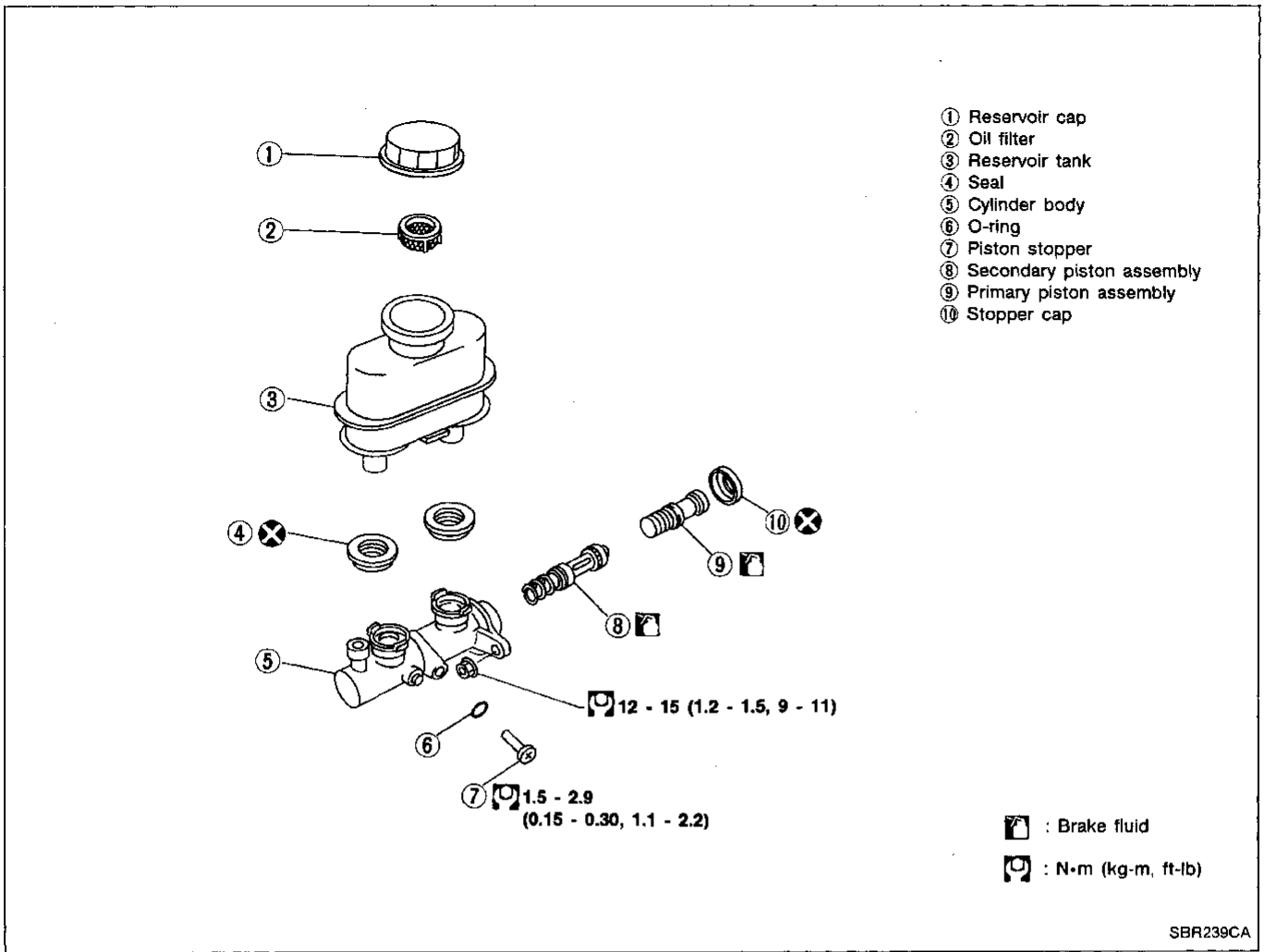

GI
 MA
 EM
 LC
 EC
 FE
 CL
 MT
 AT
 FA
 RA

Removal

CAUTION:

Be careful not to splash brake fluid on painted areas; it may cause paint damage. If brake fluid is splashed on painted areas, wash it away with water immediately.

1. Connect a vinyl tube to air bleeder valve.
2. Drain brake fluid from each air bleeder valve, depressing brake pedal to empty fluid from master cylinder.
3. Remove brake pipe flare nuts.
4. Remove master cylinder mounting nuts.

BR
 ST
 BF
 HA
 EL
 IDX

Disassembly

1. Bend claws of stopper cap outward.

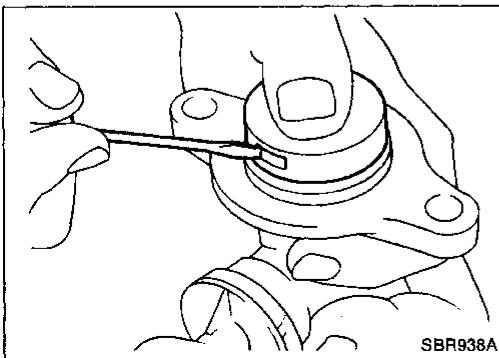

MASTER CYLINDER

Disassembly (Cont'd)

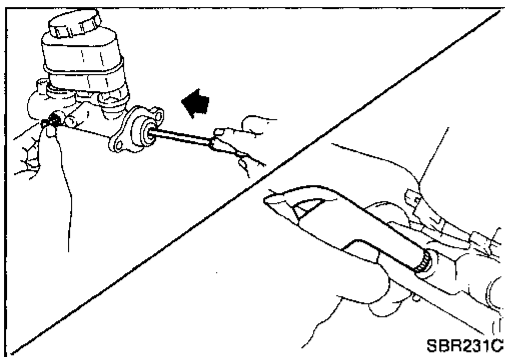

2. Remove valve stopper while piston is pushed into cylinder.
3. Remove piston assemblies.

If it is difficult to remove secondary piston assembly, gradually apply compressed air through fluid outlet.

4. Draw out reservoir tank.

Inspection

Check for the following items.

Replace any part if damaged.

Master cylinder:

- Pin holes or scratches on inner wall.

Piston:

- Deformation of or scratches on piston cups.

Assembly

1. Insert secondary piston assembly. Then insert primary piston assembly.

- Pay attention to alignment of secondary piston slit with valve stopper mounting hole of cylinder body.

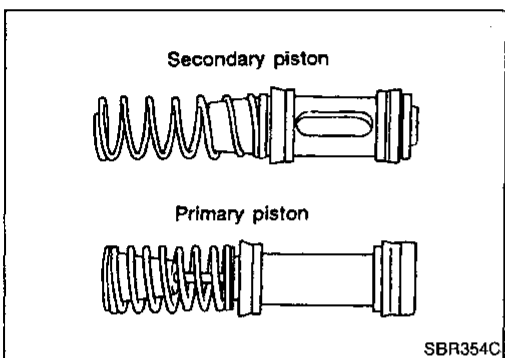

2. Install stopper cap.

Before installing stopper cap, ensure that claws are bent inward.

3. Push reservoir tank seals.
4. Push reservoir tank into master cylinder.

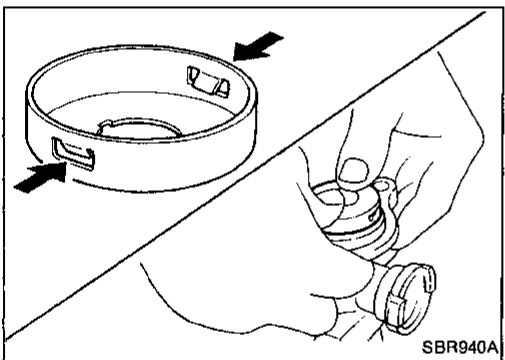

5. Install valve stopper while piston is pushed into cylinder.

Installation

CAUTION:

- Refill with new brake fluid "DOT 3".
- Never reuse drained brake fluid.

1. Place master cylinder onto brake booster and secure mounting nuts lightly.
2. Torque mounting nuts.

12 - 15 N·m (1.2 - 1.5 kg-m, 9 - 11 ft-lb)

3. Fill up reservoir tank with new brake fluid.
4. Plug all ports on master cylinder with fingers to prevent air suction while releasing brake pedal.
5. Have driver depress brake pedal slowly several times until no air comes out of master cylinder.
6. Fit brake lines to master cylinder.
7. Tighten flare nuts.

15 - 18 N·m (1.5 - 1.8 kg-m, 11 - 13 ft-lb)

8. Bleed air from brake system. Refer to "Bleeding Brake System" (BR-5).

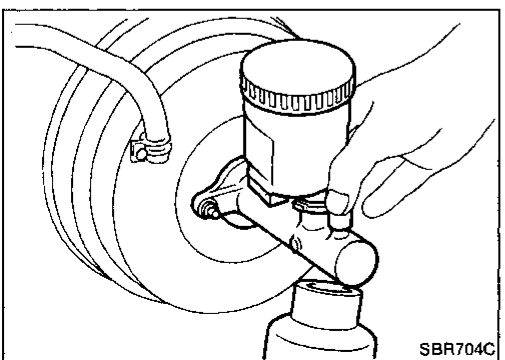
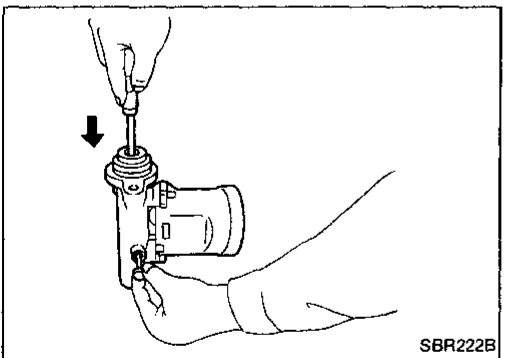

BRAKE BOOSTER/VACUUM HOSE

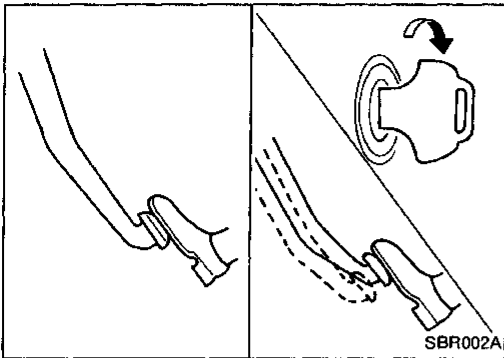

SBR002A

Brake Booster

ON-VEHICLE SERVICE

Operating check

- Stop engine and depress brake pedal several times. Check that pedal stroke does not change.
- Depress brake pedal, then start engine. If pedal goes down slightly, operation is normal.

Airtight check

- Start engine, and stop it after one or two minutes. Depress brake pedal several times slowly. The pedal should go further down the first time, and then it should gradually rise thereafter.
- Depress brake pedal while engine is running, and stop engine with pedal depressed. The pedal stroke should not change after holding pedal down for 30 seconds.

GI

MA

EM

LC

EC

FE

CL

MT

AT

FA

RA

BR

ST

BF

HA

EL

IDX

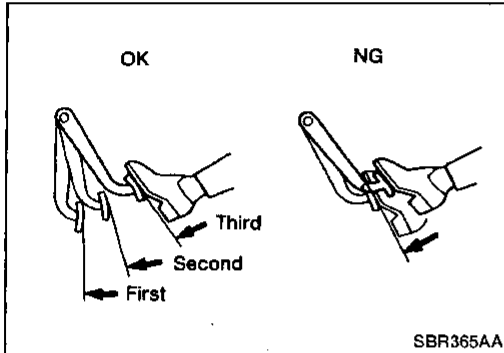

SBR365AA

REMOVAL

CAUTION:

- Be careful not to splash brake fluid on painted areas; it may cause paint damage. If brake fluid is splashed on painted areas, wash it away with water immediately.
- Be careful not to deform or bend brake pipes, during removal of booster.

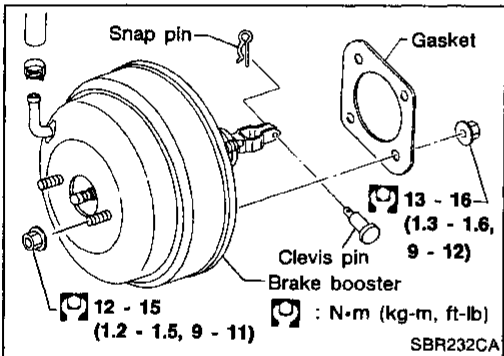

SBR232CA

INSPECTION

Output rod length check

1. Apply vacuum of -66.7 kPa (-500 mmHg, -19.69 inHg) to brake booster with a handy vacuum pump.
2. Check output rod length.

Specified length:

10.275 - 10.525 mm (0.4045 - 0.4144 in)

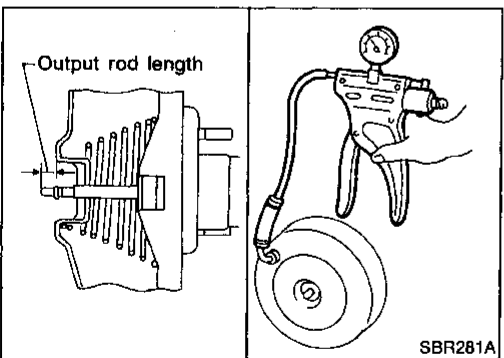

SBR281A

INSTALLATION

CAUTION:

- Be careful not to deform or bend brake pipes, during installation of booster.
- Replace clevis pin if damaged.
- Refill with new brake fluid "DOT 3".
- Never reuse drained brake fluid.
- Take care not to damage brake booster mounting bolt thread when installing. Due to the acute angle of installation, the threads can be damaged with the dash panel.

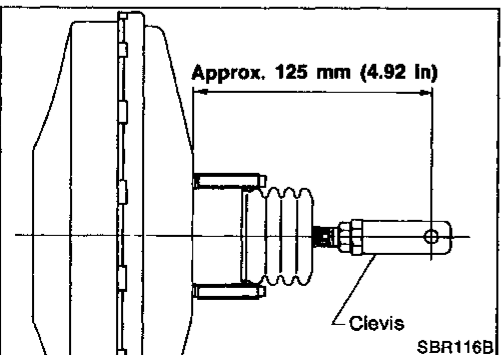

SBR116B

BRAKE BOOSTER/VACUUM HOSE

Brake Booster (Cont'd)

1. Before fitting booster, temporarily adjust clevis to dimension shown.
2. Fit booster, then secure mounting nuts (brake pedal bracket to master cylinder) lightly.
3. Connect brake pedal and booster input rod with clevis pin.
4. Secure mounting nuts.

Specification: 13 - 16 N·m (1.3 - 1.6 kg·m, 9 - 12 ft·lb)

5. Install master cylinder. Refer to "Installation" in "MASTER CYLINDER" (BR-8).
6. Bleed air. Refer to "Bleeding Brake System" (BR-5).

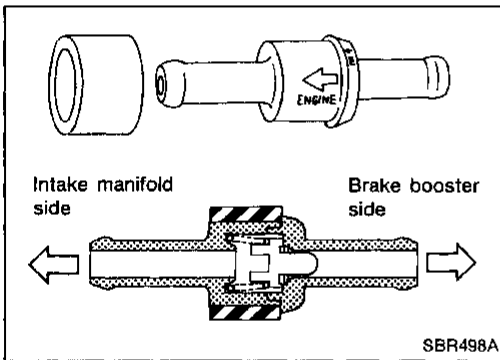
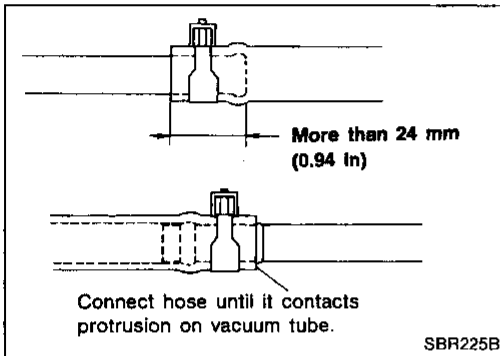

Vacuum Hose

REMOVAL AND INSTALLATION

CAUTION:

When installing vacuum hoses, pay attention to the following points.

- Do not apply any oil or lubricants to vacuum hose and check valve.
- Insert vacuum tube into vacuum hose as shown.
- Install check valve, paying attention to its direction.

INSPECTION

Hoses and connectors

Check vacuum lines, connections and check valve for airtightness, improper attachment chafing and deterioration.

Check valve

Check vacuum with a vacuum pump.

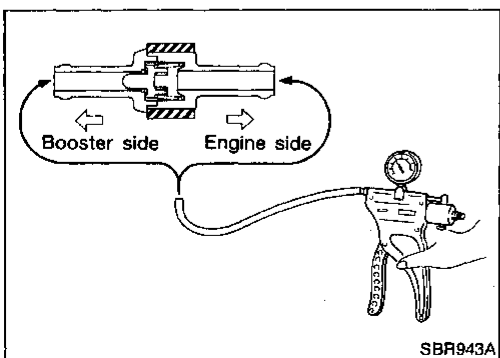

Connect to booster side	Vacuum should exist.
Connect to engine side	Vacuum should not exist.

FRONT DISC BRAKE

Pad Replacement

WARNING:

Clean brake pads with a vacuum dust collector to minimize the hazard of airborne particles or other materials.

CAUTION:

- When cylinder body is open, do not depress brake pedal because piston will pop out.
- Be careful not to damage piston boot or get oil on rotor. Always replace shims when replacing pads.
- If shims are rusted or show peeling of the rubber coat, replace them with new shims.
- It is not necessary to remove connecting bolt except for disassembly or replacement of caliper assembly. In this case, suspend cylinder body with wire so as not to stretch brake hose.

GI

MA

EM

LC

EC

FE

CL

MT

AT

FA

RA

BR

ST

BF

HA

EL

IDX

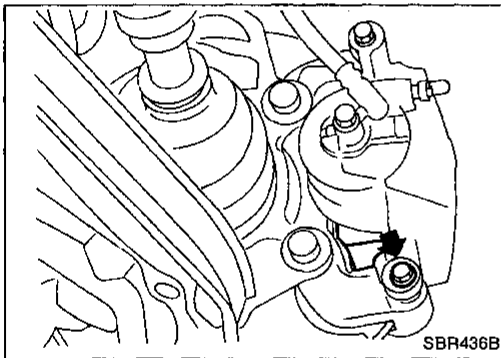

1. Remove master cylinder reservoir cap.
2. Remove pin bolt.
3. Open cylinder body upward. Then remove pad retainers, and inner and outer shims.

Standard pad thickness:

11 mm (0.43 in)

Pad wear limit:

2.0 mm (0.079 in)

Carefully monitor brake fluid level because brake fluid will return to reservoir when pushing back piston.

FRONT DISC BRAKE

CL25VA

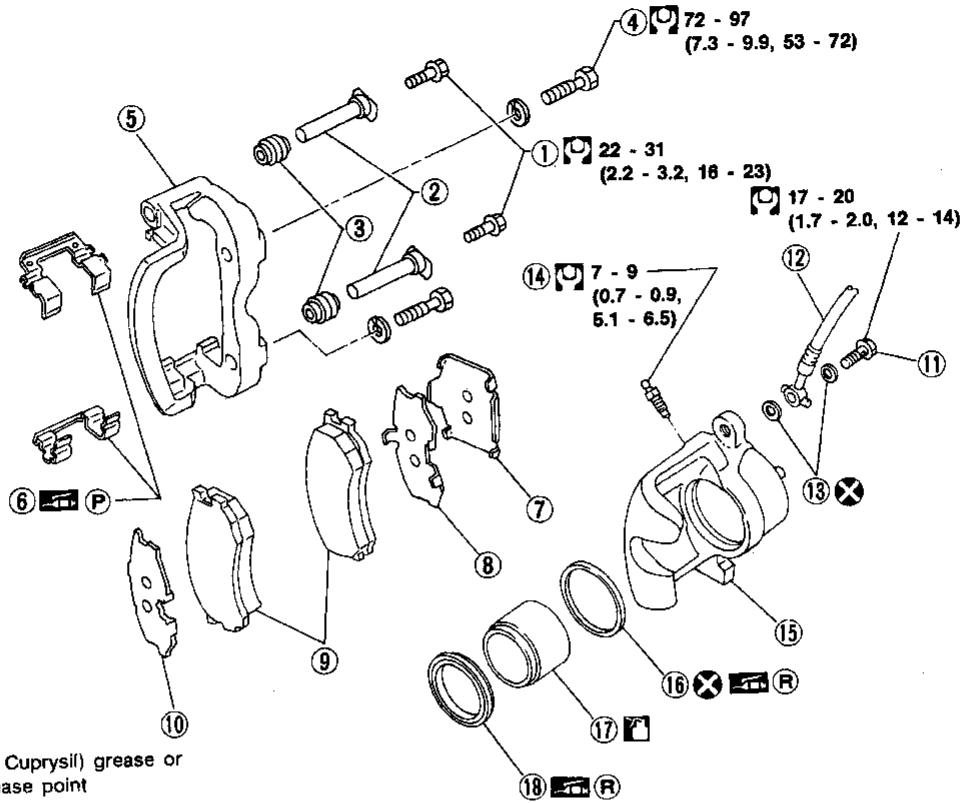

- P : P.B.C. (Poly Butyl Cuprysil) grease or silicone-based grease point
- R : Rubber grease point
- : Brake fluid
- : N·m (kg-m, ft-lb)

SBR353C

- | | | |
|-----------------------------|-------------------|-----------------|
| ① Main pin bolt | ⑦ Shim cover | ⑬ Copper washer |
| ② Pin | ⑧ Inner shim | ⑭ Air bleeder |
| ③ Pin boot | ⑨ Pad | ⑮ Cylinder body |
| ④ Torque member fixing bolt | ⑩ Outer shim | ⑯ Piston seal |
| ⑤ Torque member | ⑪ Connecting bolt | ⑰ Piston |
| ⑥ Pad retainer | ⑫ Brake hose | ⑱ Piston boot |

Removal

WARNING:

Clean brake pads with a vacuum dust collector to minimize the hazard of airborne particles or other materials.

FRONT DISC BRAKE

Removal (Cont'd)

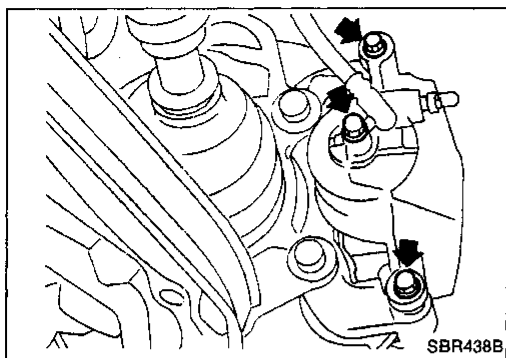

Remove torque member fixing bolts and connecting bolt.

It is not necessary to remove connecting bolt except for disassembly or replacement of caliper assembly. In this case, suspend caliper assembly with wire so as not to stretch brake hose.

GI

MA

EM

LC

EC

FE

CL

MT

AT

FA

RA

BR

ST

BF

HA

EL

IDX

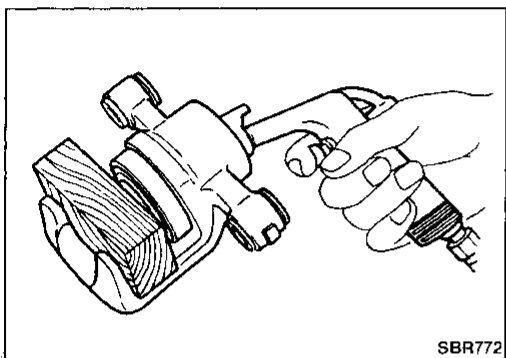

Disassembly

WARNING:

Do not place your fingers in front of piston.

CAUTION:

Do not scratch or score cylinder wall.

1. Push out piston with piston boot with compressed air.
2. Remove piston seal with a suitable tool.

Inspection — Caliper

CYLINDER BODY

- Check inside surface of cylinder for score, rust, wear, damage or presence of foreign materials. If any of the above conditions are observed, replace cylinder body.
- Minor damage from rust or foreign materials may be eliminated by polishing surface with a fine emery paper. Replace cylinder body if necessary.

CAUTION:

Use brake fluid to clean. Never use mineral oil.

PISTON

CAUTION:

Piston sliding surface is plated. Do not polish with emery paper even if rust or foreign materials are stuck to sliding surface.

Check piston for score, rust, wear, damage or presence of foreign materials. Replace if any of the above conditions are observed.

SLIDE PIN, PIN BOLT AND PIN BOOT

Check for wear, cracks or other damage. Replace if any of the above conditions are observed.

Inspection — Rotor

RUBBING SURFACE

Check rotor for roughness, cracks or chips.

FRONT DISC BRAKE

Inspection — Rotor (Cont'd)

RUNOUT

1. Secure rotor to wheel hub with at least two nuts (M12 x 1.25).
2. Check runout using a dial indicator.

Make sure that wheel bearing axial end play is within the specifications before measuring. Refer to "Front Wheel Bearing" in FA section.

**Maximum runout:
0.07 mm (0.0028 in)**

3. If the runout is out of specification, find minimum runout position as follows:
 - a. Remove nuts and rotor from wheel hub.
 - b. Shift the rotor one hole and secure rotor to wheel hub with nuts.
 - c. Measure runout.
 - d. Repeat steps a. to c. so that minimum runout position can be found.
4. If the runout is still out of specification, turn rotor with on-car brake lathe ("MAD, DL-8700", "AMMCO 700 and 705" or equivalent).

THICKNESS

**Thickness variation (At least 8 positions):
Maximum 0.01 mm (0.0004 in)**

If thickness variation exceeds the specification, turn rotor with on-car brake lathe.

**Rotor repair limit:
20.0 mm (0.787 in)**

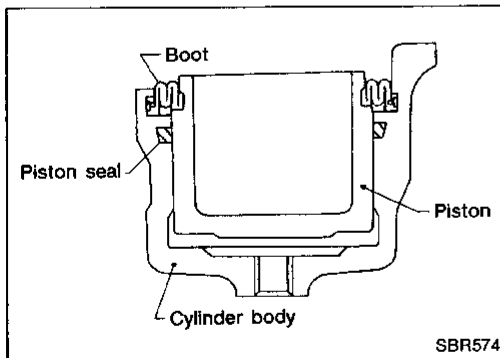
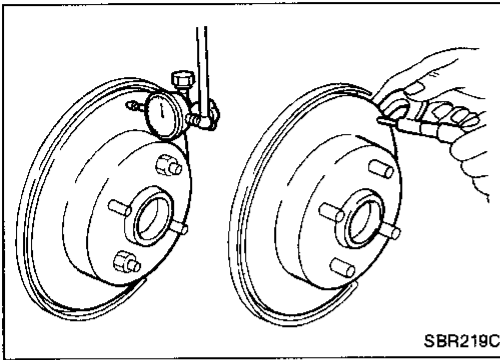

Assembly

1. Insert piston seal into groove on cylinder body.
2. With piston boot fitted to piston, insert piston boot into groove on cylinder body and install piston.
3. Properly secure piston boot.

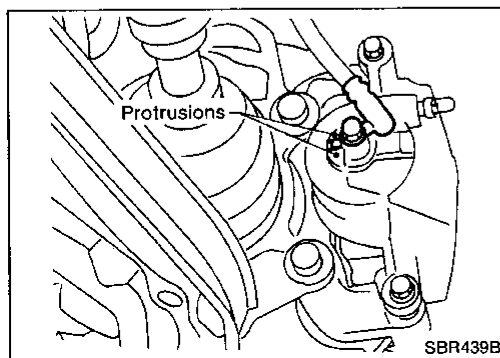

Installation

CAUTION:

- Refill with new brake fluid "DOT 3".
 - Never reuse drained brake fluid.
1. Install brake hose to caliper securely.
 2. Install all parts and secure all bolts.
 3. Bleed air. Refer to "Bleeding Brake System" (BR-5).

REAR DISC BRAKE

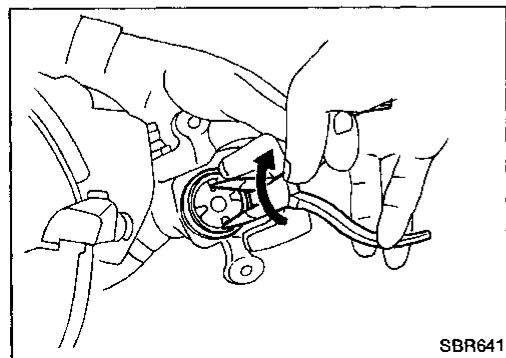
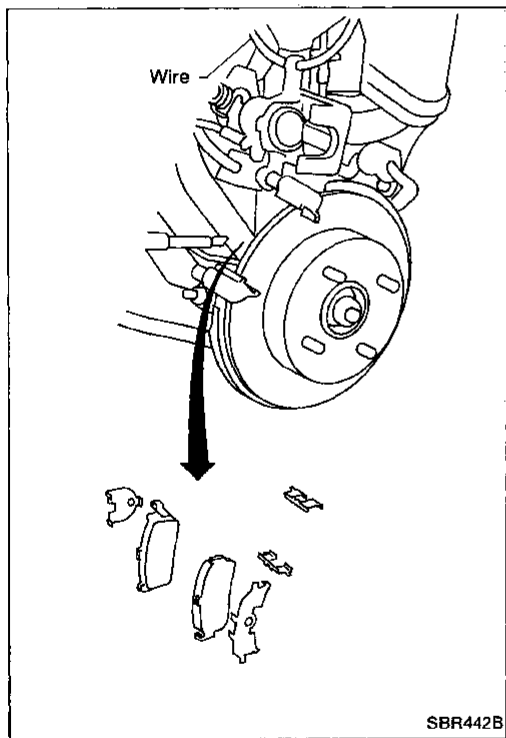
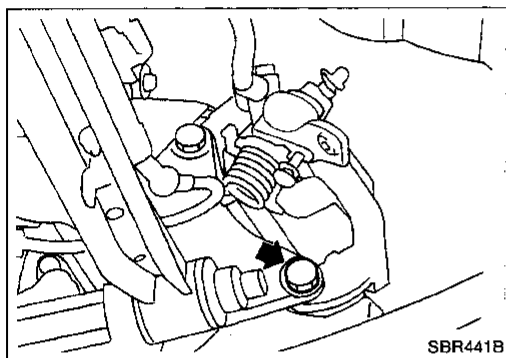
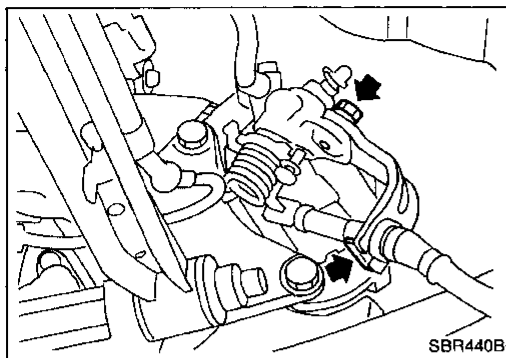

Pad Replacement

WARNING:

Clean brake pads with a vacuum dust collector to minimize the hazard of airborne particles or other materials.

CAUTION:

- When cylinder body is open, do not depress brake pedal because piston will pop out.
- Be careful not to damage piston boot or get oil on rotor. Always replace shims in replacing pads.
- If shims are rusted or show peeling of rubber coat, replace them with new shims.
- It is not necessary to remove connecting bolt except for disassembly or replacement of caliper assembly. In this case, suspend cylinder body with wire so as not to stretch brake hose.

1. Remove master cylinder reservoir cap.
2. Remove brake cable mounting bracket bolt and lock spring.
3. Disconnect cable.
4. Remove pin bolt.

5. Open cylinder body upward. Then remove pad retainers, and inner and outer shims.

Standard pad thickness:

10 mm (0.39 in)

Pad wear limit:

1.5 mm (0.059 in)

6. When installing new pads, push piston into cylinder body by gently turning piston clockwise, as shown.

Carefully monitor brake fluid level because brake fluid will return to reservoir when pushing back piston.

GI

MA

EM

LC

EC

FE

CL

MT

AT

FA

RA

BR

ST

BF

HA

EL

IDX

REAR DISC BRAKE

CL9HA

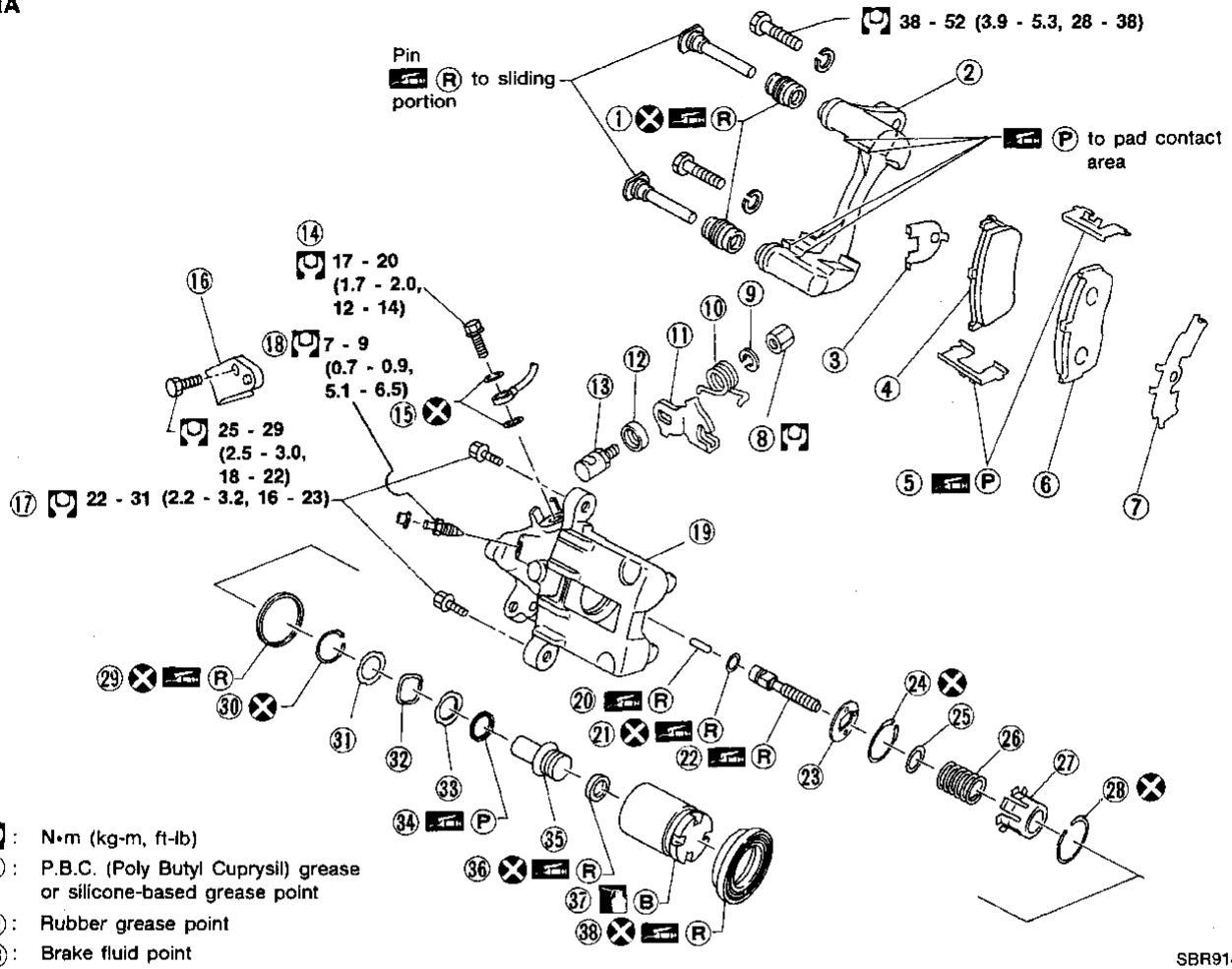

SBR914B

- | | | |
|-----------------|--------------------------|-----------------|
| ① Pin boot | ⑭ Connecting bolt | ⑳ Spring cover |
| ② Torque member | ⑮ Copper washer | ㉑ Ring B |
| ③ Outer shim | ⑯ Cable mounting bracket | ㉒ Piston seal |
| ④ Pad | ⑰ Pin bolt | ㉓ Ring A |
| ⑤ Pad retainer | ⑱ Bleed screw | ㉔ Spacer |
| ⑥ Pad | ⑲ Cylinder | ㉕ Wave washer |
| ⑦ Inner shim | ⑳ Rod | ㉖ Spacer |
| ⑧ Nut | ㉑ O-ring | ㉗ Ball bearing |
| ⑨ Spring washer | ㉒ Push rod | ㉘ Adjusting nut |
| ⑩ Return spring | ㉓ Key plate | ㉙ Cup |
| ⑪ Lever | ㉔ Ring C | ㉚ Piston |
| ⑫ Cam boot | ㉕ Seat | ㉛ Piston boot |
| ⑬ Adjusting cam | ㉖ Spring | |

REAR DISC BRAKE

Removal

WARNING:

Clean brake pads with a vacuum dust collector to minimize the hazard of airborne particles or other materials.

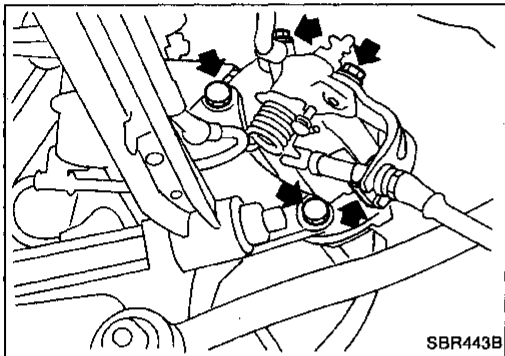

1. Remove brake cable mounting bracket bolt and lock spring.
2. Remove torque member fixing bolts and connecting bolt.

It is not necessary to remove connecting bolt except for disassembly or replacement of callper assembly. In this case, suspend callper assembly with wire so as not to stretch brake hose.

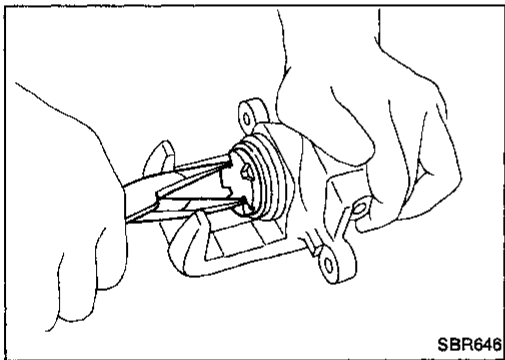

Disassembly

1. Remove piston by turning it counterclockwise with suitable long nose pliers.

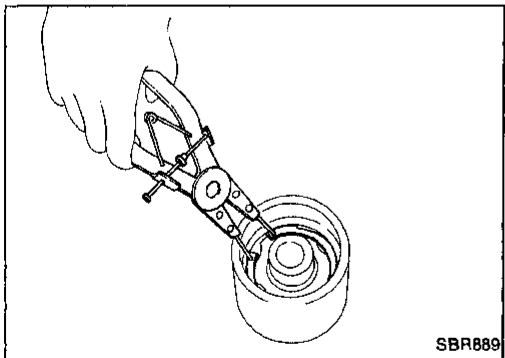

2. Pry off ring A from piston with suitable pliers and remove adjusting nut.

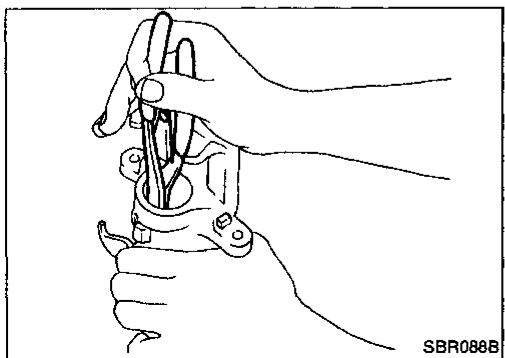

3. Disassemble cylinder body.
 - a. Pry off ring B with suitable pliers, then remove spring cover, spring and seat.
 - b. Pry off ring C, then remove key plate, push rod and rod.

GI

MA

EM

LC

EC

FE

CL

MT

AT

FA

RA

BR

ST

BF

HA

EL

IDX

REAR DISC BRAKE

Disassembly (Cont'd)

c. Remove piston seal.

Be careful not to damage cylinder body.

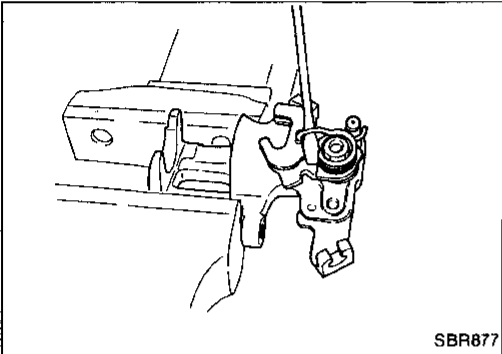
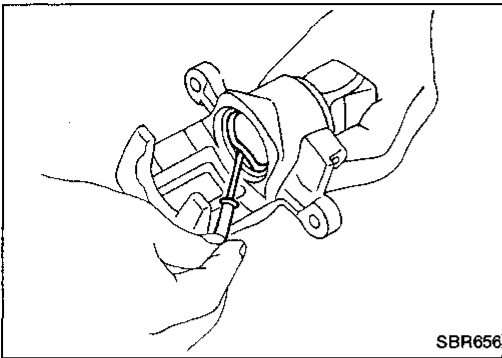

4. Remove return spring, stopper bolt and lever.

Inspection — Caliper

CAUTION:

Use brake fluid to clean cylinder. Never use mineral oil.

CYLINDER BODY

- Check inside surface of cylinder for score, rust, wear, damage or presence of foreign materials. If any of the above conditions are observed, replace cylinder body.
- Minor damage from rust or foreign materials may be eliminated by polishing surface with a fine emery paper. Replace cylinder body if necessary.

TORQUE MEMBER

Check for wear, cracks or other damage. Replace if necessary.

PISTON

CAUTION:

Piston sliding surface is plated. Do not polish with emery paper even if rust or foreign matter is stuck to sliding surface.

Check piston for score, rust, wear, damage or presence of foreign materials.

Replace if any of the above conditions are observed.

PIN AND PIN BOOT

Check for wear, cracks or other damage.

Replace if any of the above conditions are observed.

REAR DISC BRAKE

Inspection — Rotor

RUBBING SURFACE

Check rotor for roughness, cracks or chips.

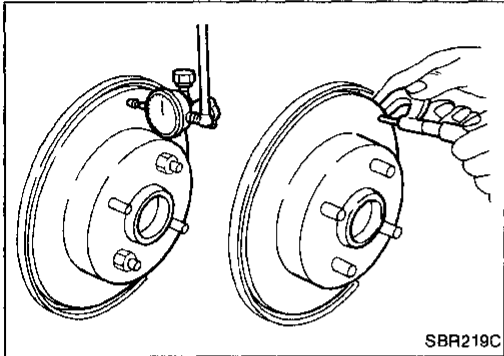

RUNOUT

1. Secure rotor to wheel hub with two nuts (M12 x 1.25).
2. Check runout using a dial indicator.

Make sure that axial end play is within the specifications before measuring. Refer to "Rear Wheel Bearing" in RA section.

3. Change relative positions of rotor and wheel hub so that runout is minimized.

**Maximum runout:
0.07 mm (0.0028 in)**

THICKNESS

Rotor repair limit:

**Standard thickness
9 mm (0.35 in)**

**Minimum thickness
8 mm (0.31 in)**

**Thickness variation (At least 8 portions)
Maximum 0.02 mm (0.0008 in)**

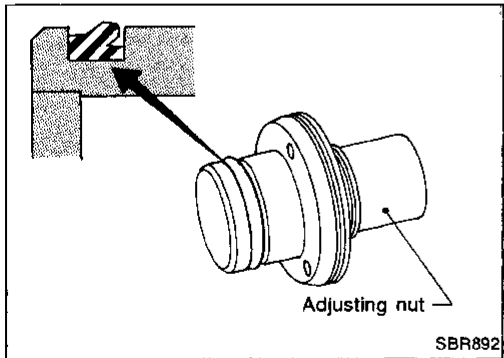

Assembly

1. Install cup in the specified direction.

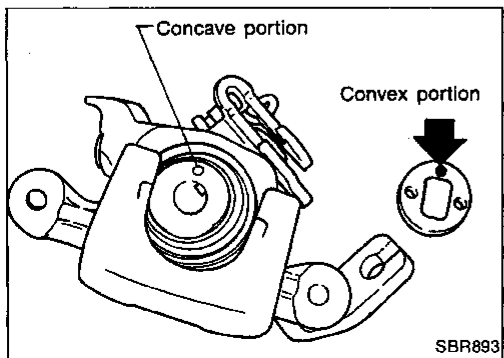

2. Fit push rod into square hole in key plate. Also match convex portion of key plate with concave portion of cylinder.

GI

MA

EM

LC

EC

FE

CL

MT

AT

FA

RA

BR

ST

BF

HA

EL

IDX

REAR DISC BRAKE

Assembly (Cont'd)

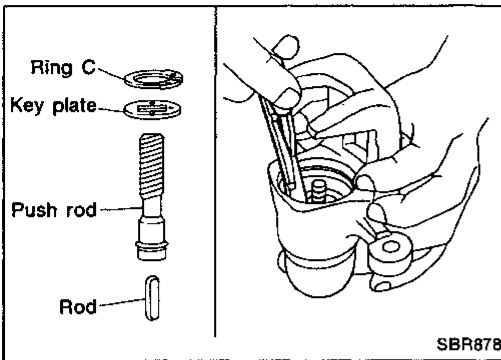

3. Install ring C with a suitable tool.

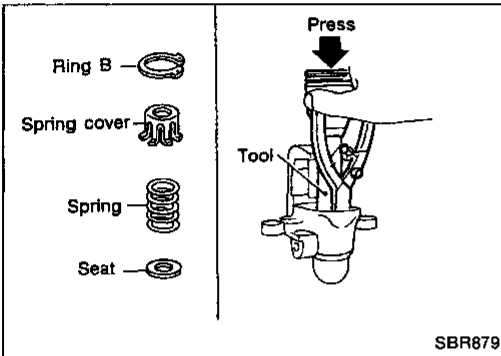

4. Install seat, spring, spring cover and ring B with suitable press and drift.

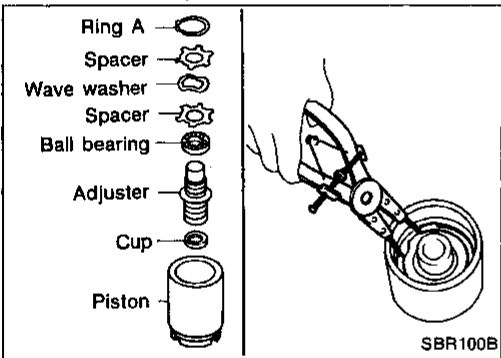

5. Install cup, adjuster, bearing, spacers, washers and ring A with a suitable tool.

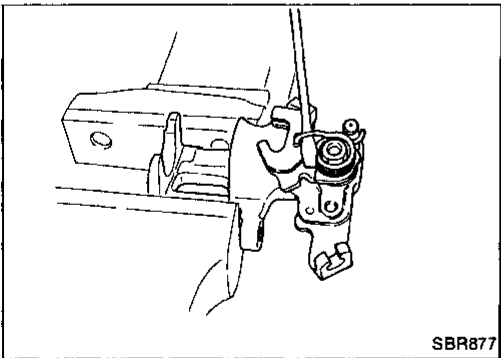

6. Fit lever and tighten stopper bolt.
7. Fit return spring in the order shown.

Installation

CAUTION:

- Refill with new brake fluid "DOT 3".
 - Never reuse drained brake fluid.
1. Install brake hose to caliper securely.
 2. Install all parts and secure all bolts.
 3. Bleed air. Refer to "Bleeding Brake System" (BR-5).

PARKING BRAKE CONTROL

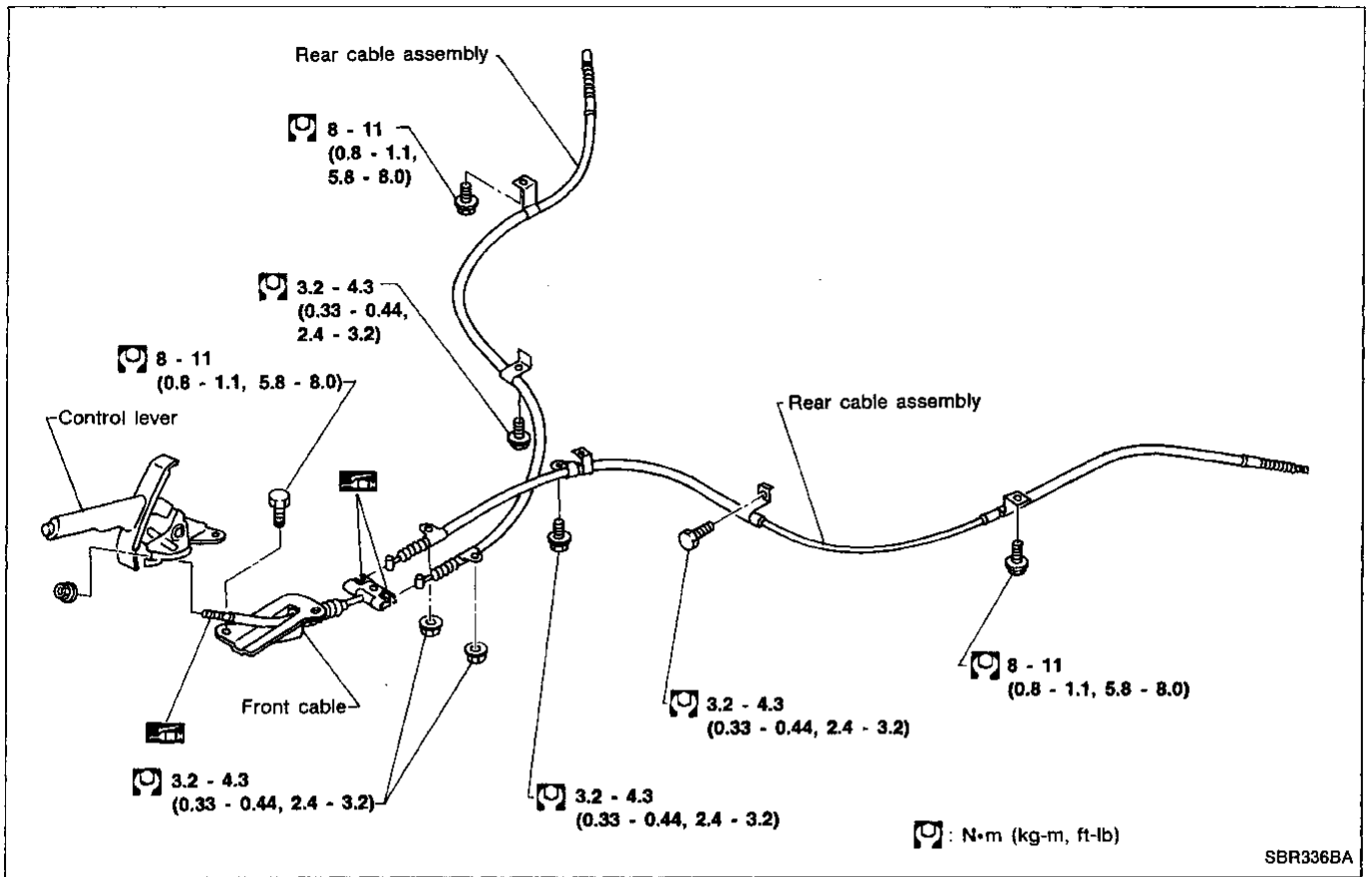

GI
MA
EM
LC
EC
FE
CL
MT
AT

FA
RA

BR

ST

BF

HA

EL

IDX

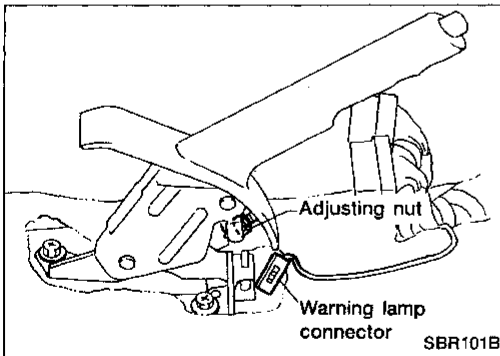

Removal and Installation

1. To remove parking brake cable, first remove center console.
2. Disconnect warning lamp connector.
3. Remove bolts, slacken off and remove adjusting nut.
4. Remove cable mounting bracket and lock plate.

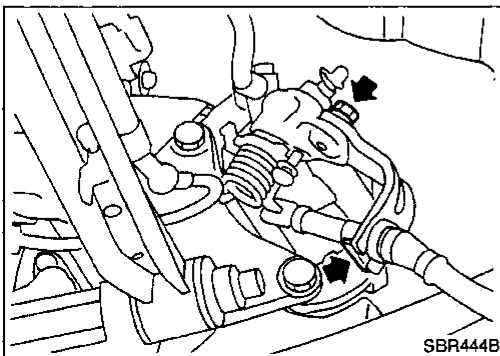

PARKING BRAKE CONTROL

Inspection

1. Check control lever for wear or other damage. Replace if necessary.
2. Check wires for discontinuity or deterioration. Replace if necessary.
3. Check warning lamp and switch. Replace if necessary.
4. Check parts at each connecting portion and, if found deformed or damaged, replace.

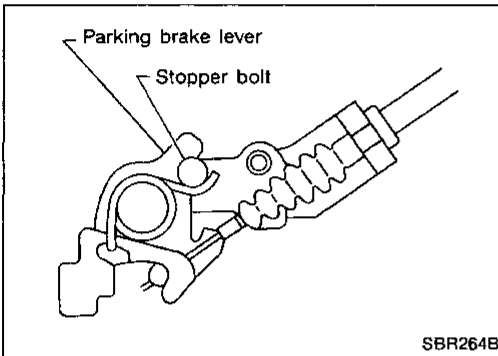

Adjustment

Pay attention to the following points after adjustment.

- a. There is no drag when control lever is being released.
- b. Parking brake lever returns to stopper bolt when control lever for rear disc brake models is released.

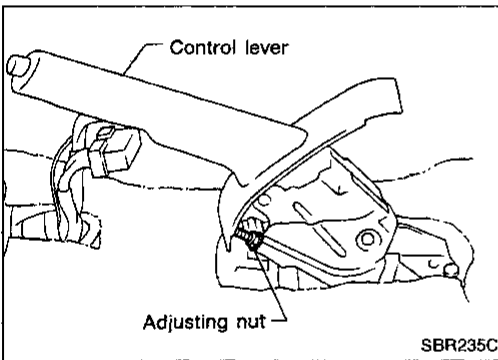

1. Loosen parking brake cable.
2. Depress brake pedal fully more than 5 times.
3. Adjust control lever by turning adjusting nut.
4. Pull control lever with specified amount of force. Check lever stroke and ensure smooth operation.
Number of notches : 6 - 8 [196 N (20 kg, 44 lb)]
5. Bend warning lamp switchplate. Warning lamp should come on when lever is pulled "A" notches. It should go off when the lever is fully released.
Number of "A" notches : 1

ANTI-LOCK BRAKE SYSTEM

Purpose

The ABS consists of electronic and hydraulic components. It allows for control of braking force so that locking of the wheels can be avoided.

The ABS:

- 1) Ensures proper tracking performance through steering wheel operation.
- 2) Enables obstacles to be avoided through steering wheel operation.
- 3) Ensures vehicle stability by preventing flat spins.

Operation

- When the vehicle speed is less than 10 km/h (6 MPH) this system does not work.
- The Anti-Lock Brake System (ABS) has self-test capabilities. The system turns on the anti-lock warning light for 1 second after turning the ignition switch ON. The system performs another test the first time the vehicle reaches 6 km/h (4 MPH). A mechanical noise may be heard as the ABS performs a self-test. This is a normal part of the self-test feature. If a malfunction is found during this check, the anti-lock warning light will come on.
- During ABS operation, a mechanical noise may be heard. This is a normal condition.

ABS Hydraulic Circuit

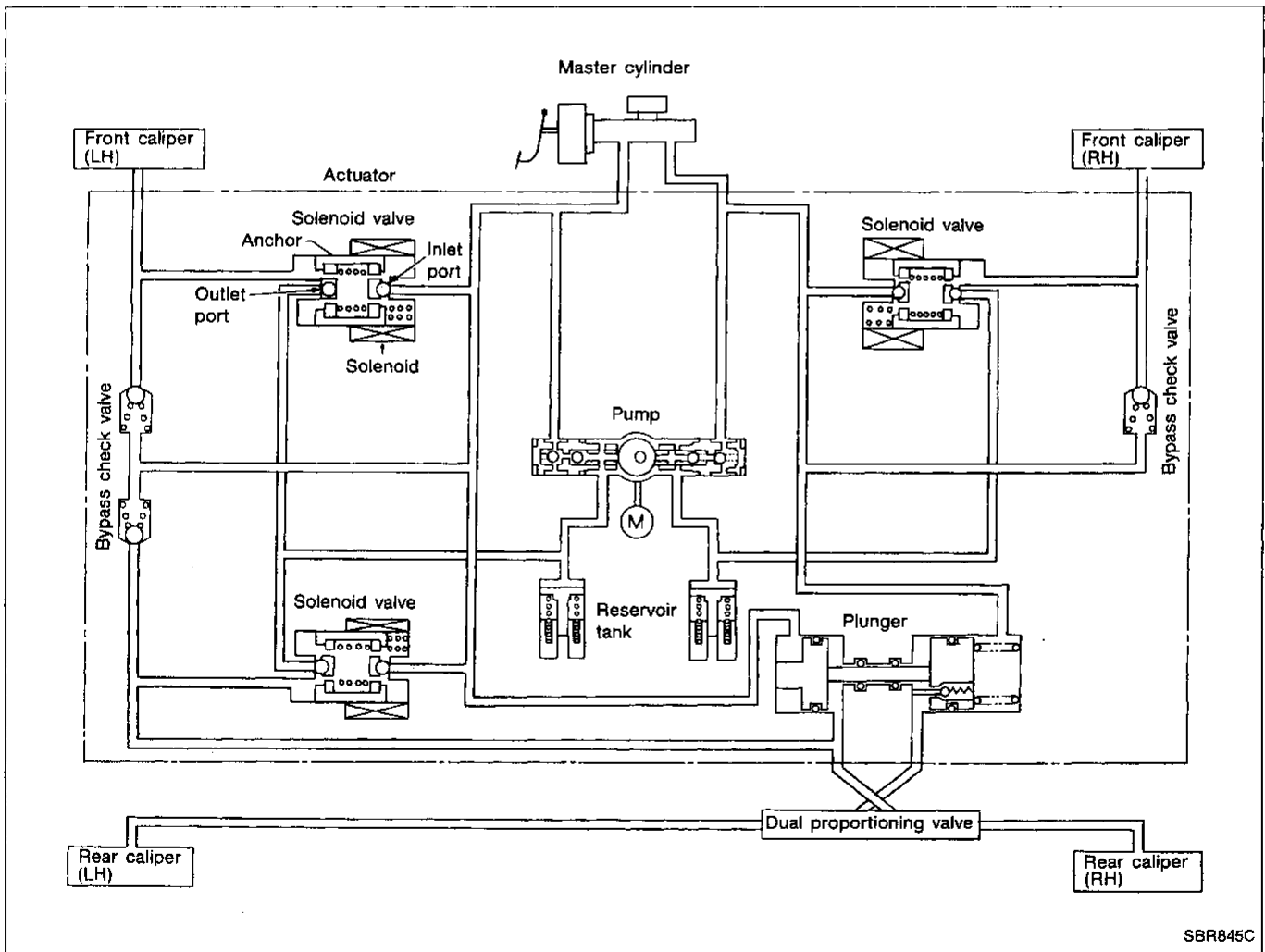

ANTI-LOCK BRAKE SYSTEM

System Components

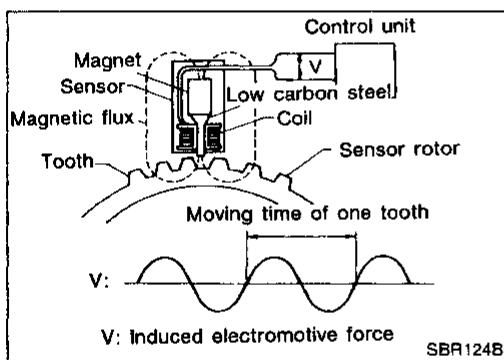
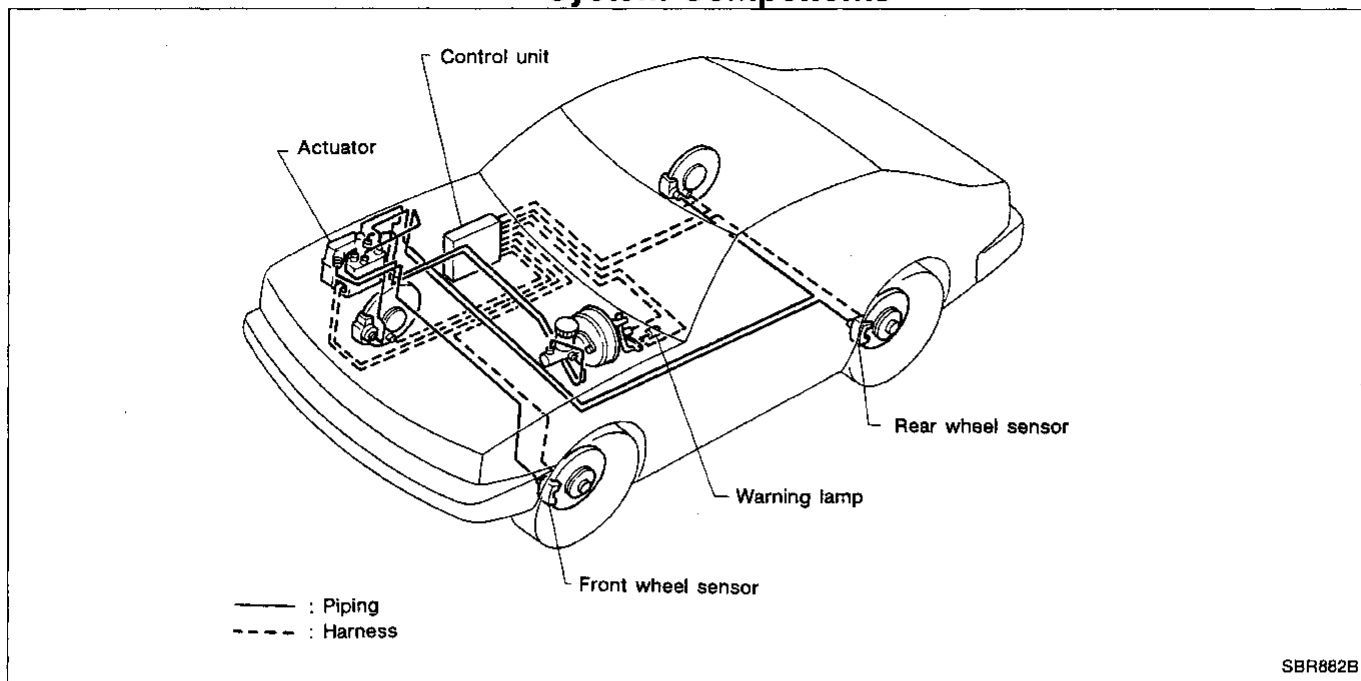

System Description

SENSOR

The sensor unit consists of a gear-shaped sensor rotor and a sensor element. The element contains a bar magnet around which a coil is wound. The sensor is installed on the back side of the brake rotor. Sine-wave current is generated by the sensor as the wheel rotates. The frequency and voltage increase(s) as the rotating speed increases.

CONTROL UNIT

The control unit computes the wheel rotating speed by the signal current sent from the sensor. Then it supplies a DC current (about either 5 or 2 amperes) to the actuator solenoid valve. It also controls ON-OFF operation of the valve relay and pump relay. If any electrical malfunction should be detected in the system, the warning light is turned on. In this condition, the ABS will be deactivated, and the vehicle's brake system reverts to normal operation.

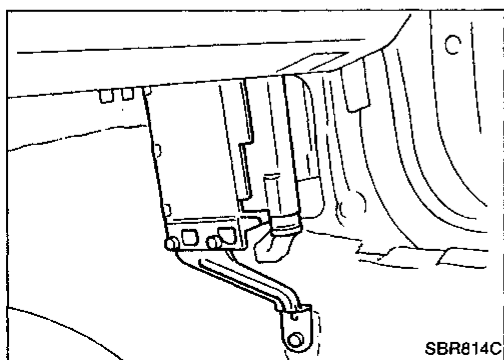
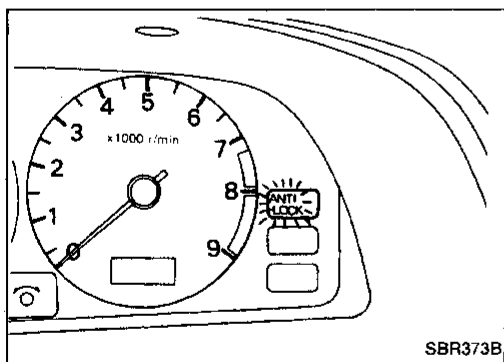

ANTI-LOCK BRAKE SYSTEM

Removal and Installation

CAUTION:

Be careful not to damage sensor edge and sensor rotor teeth. When removing the front or rear wheel hub assembly, disconnect the ABS wheel sensor from the assembly and move it away. Failure to do so may result in damage to the sensor wires making the sensor inoperative.

FRONT WHEEL SENSOR

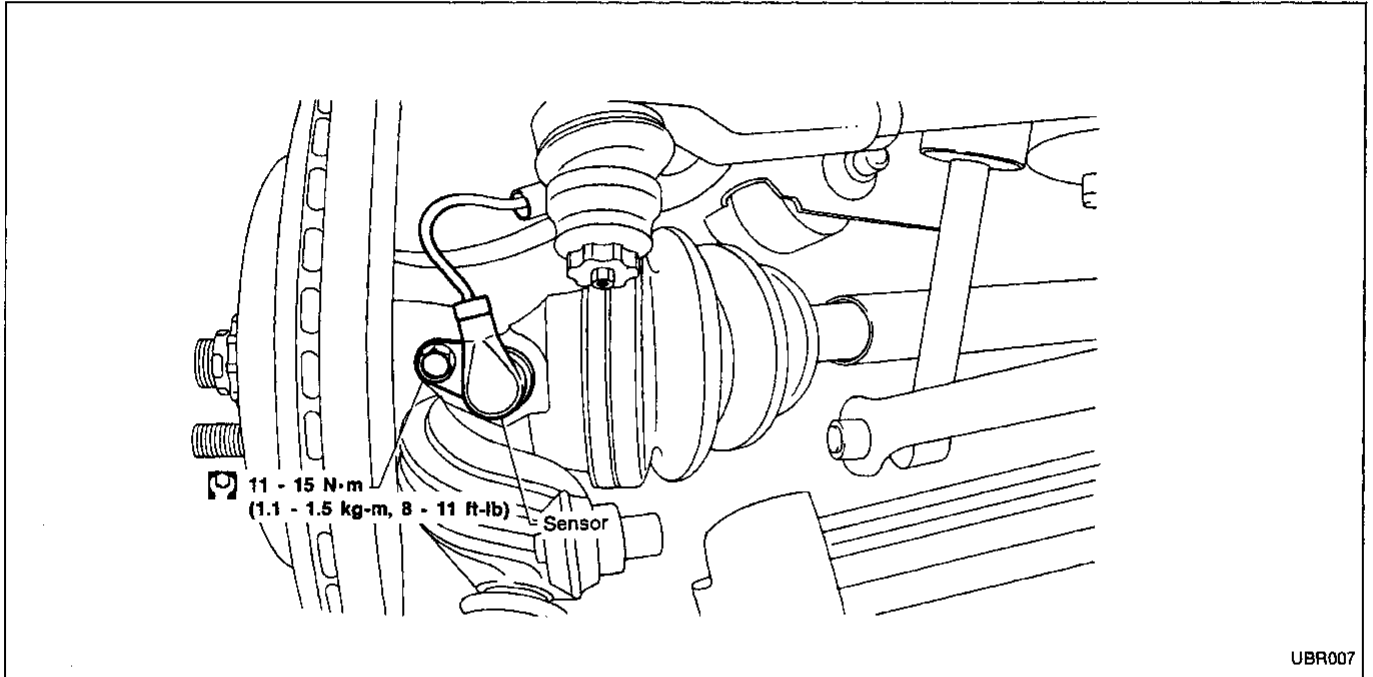

REAR SENSOR

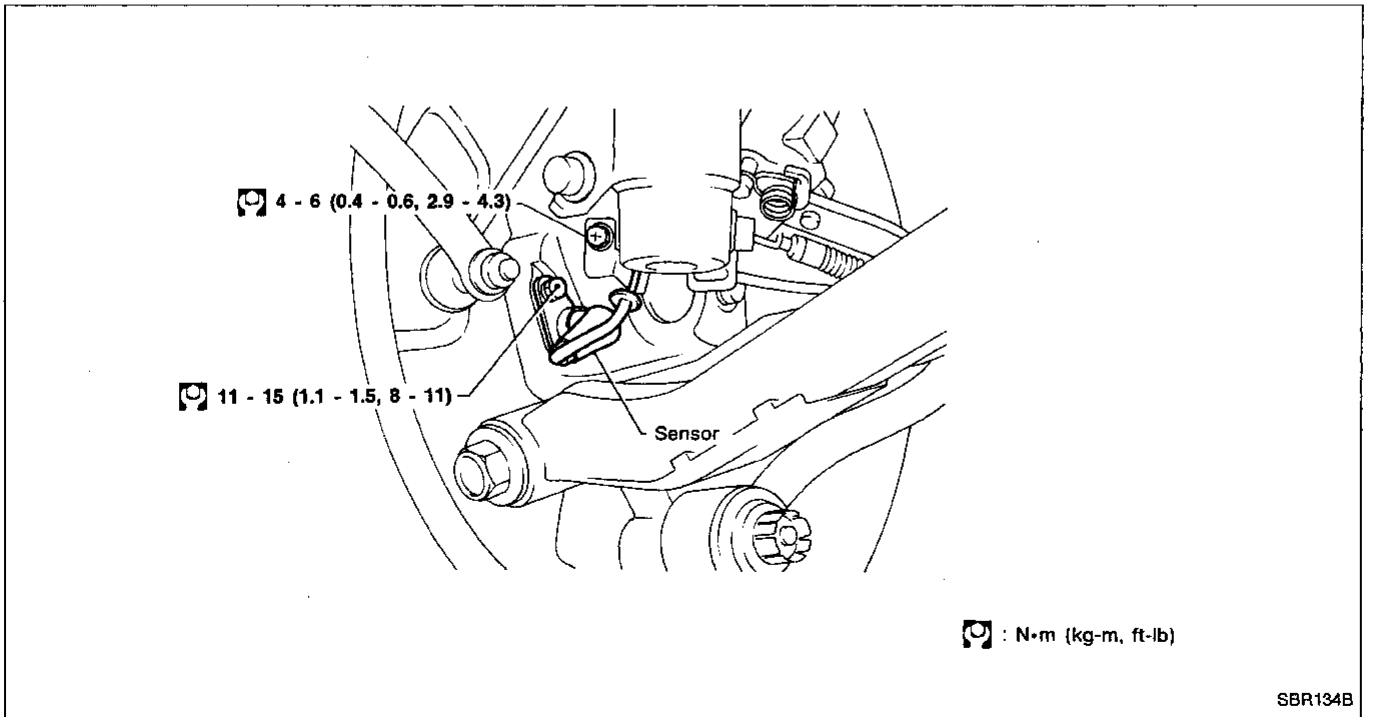

GI

MA

EM

LC

EC

FE

CL

MT

AT

FA

RA

BR

ST

BF

HA

EL

IDX

ANTI-LOCK BRAKE SYSTEM

Removal and Installation (Cont'd)

CONTROL UNIT

Location: Front passenger side dash side lower.

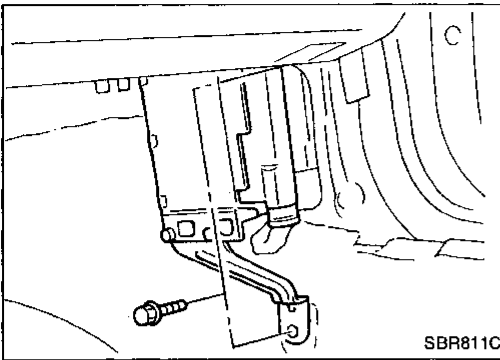

ACTUATOR

Removal

1. Disconnect battery cable.
2. Drain brake fluid. Refer to "Changing Brake Fluid" (BR-5).
3. Apply different colored paint to each pipe connector and actuator to prevent incorrect connection.
4. Disconnect connector, brake pipes and remove fixing nuts and actuator ground cable.

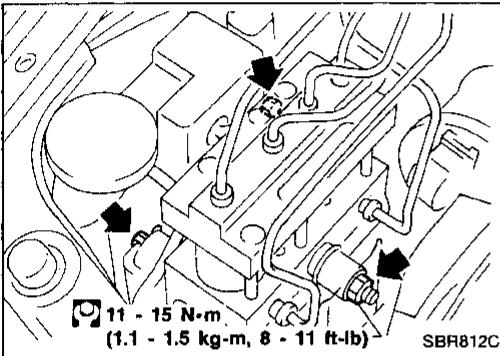

Installation

CAUTION:

After installation, refill brake fluid. Then bleed air. Refer to "Bleeding Brake System" (BR-5).

1. Tighten actuator ground cable.
2. Connect brake pipes temporarily.
3. Tighten fixing nuts.
4. Tighten brake pipes.
5. Connect connector and battery cable.

ACTUATOR RELAYS

LARGE: Motor Relay

SMALL: Solenoid Valve Relay

1. Disconnect battery cable.
2. Remove actuator relay cover.
3. Pull out relays.

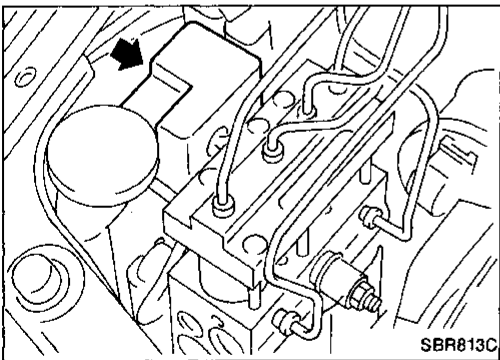

ANTI-LOCK BRAKE SYSTEM

Wiring Diagram — ABS —

BR-ABS-01

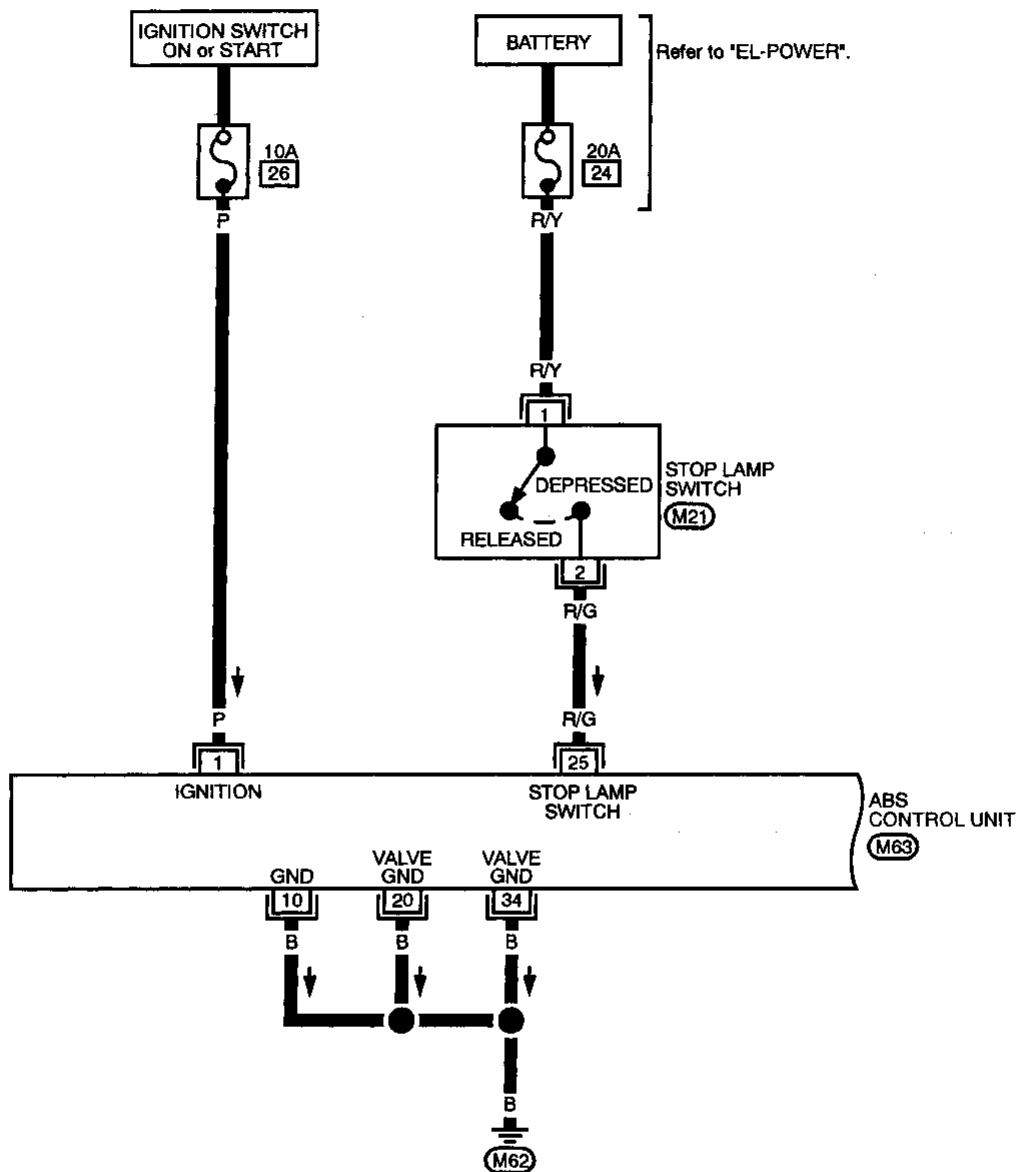

GI
MA
EM
LC
EC
FE
CL
MT
AT
FA
RA
BR
ST
BF
HA
EL
IDX

ANTI-LOCK BRAKE SYSTEM

Wiring Diagram — ABS — (Cont'd)

BR-ABS-02

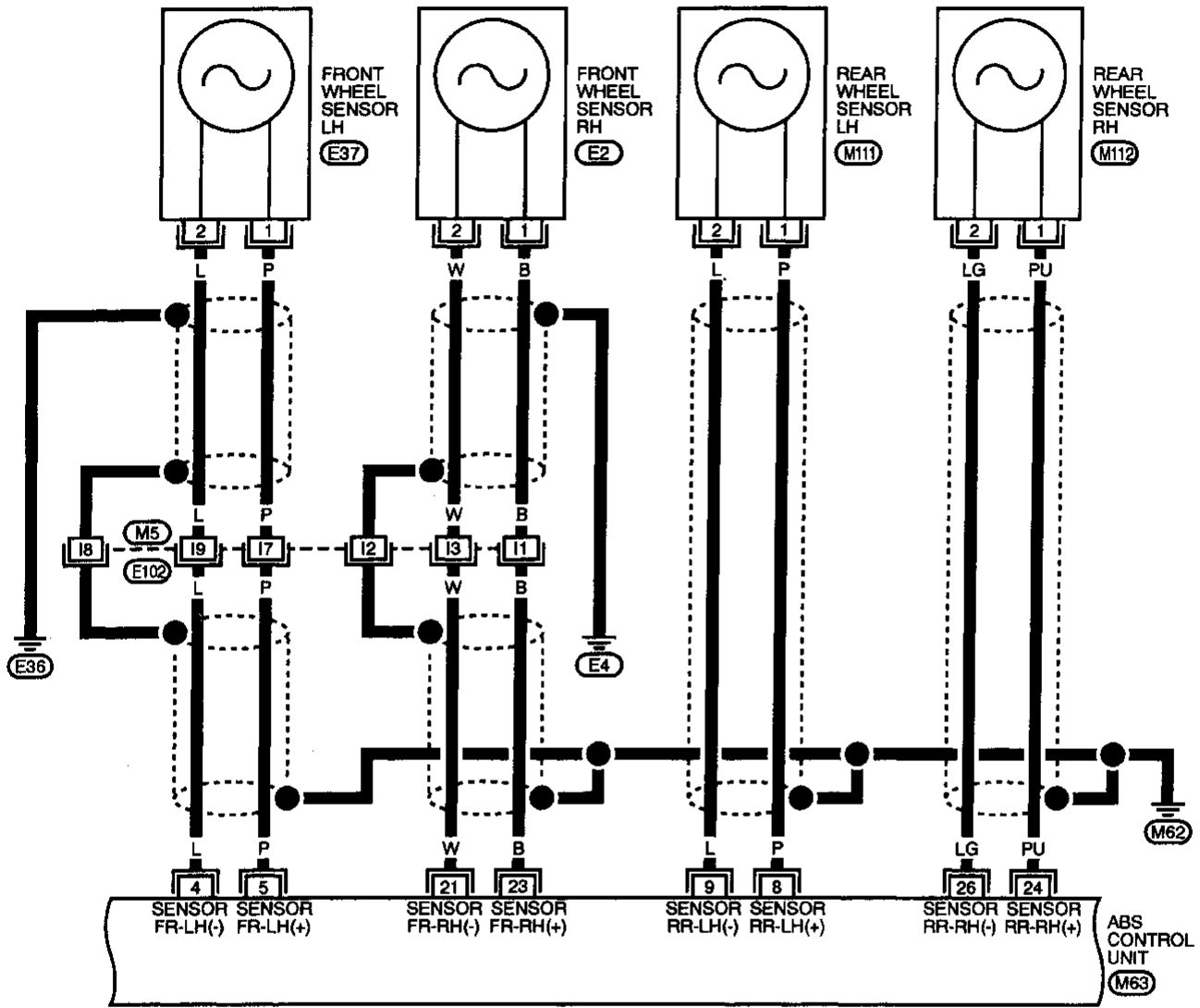

Refer to last page (Foldout page).

M5, E102

1 2 E2 E37 M11 M12
GY GY BR GY

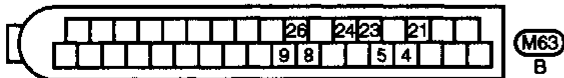

ANTI-LOCK BRAKE SYSTEM

Wiring Diagram — ABS — (Cont'd)

BR-ABS-03

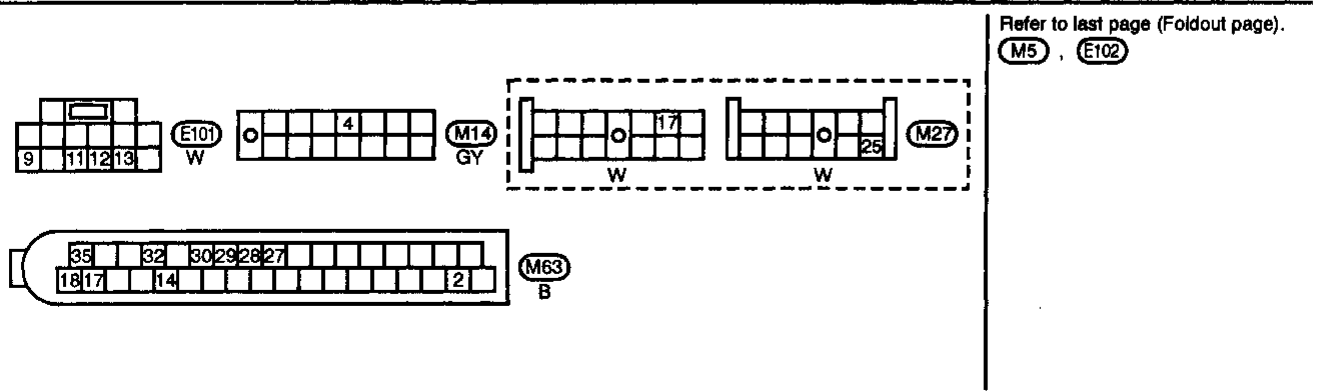
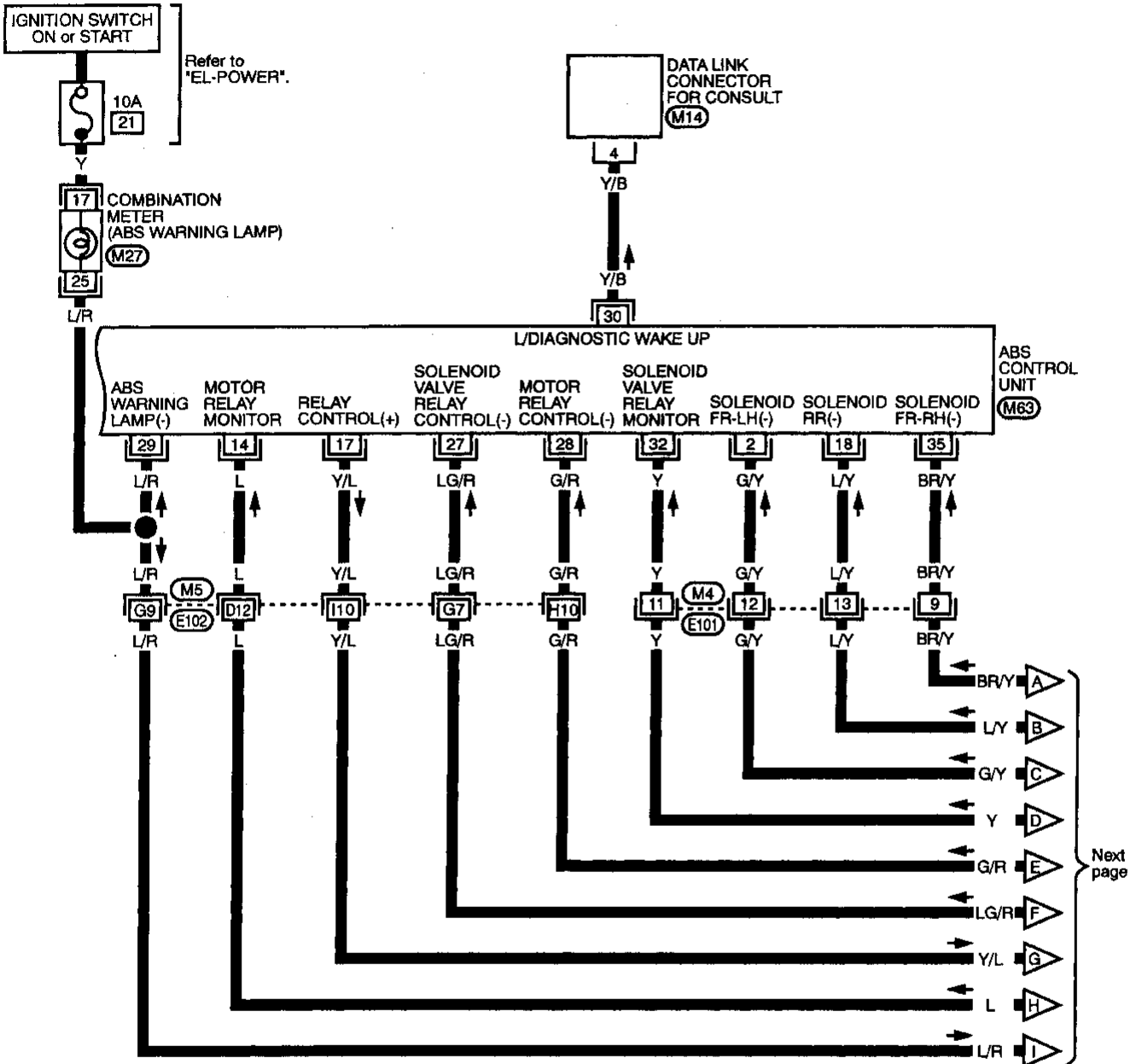

GI
MA
EM
LC
EC
FE
CL
MT
AT
FA
RA
BR
ST
BF
HA
EL
IDX

ANTI-LOCK BRAKE SYSTEM

Wiring Diagram — ABS — (Cont'd)

BR-ABS-04

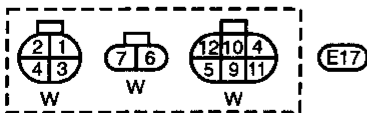
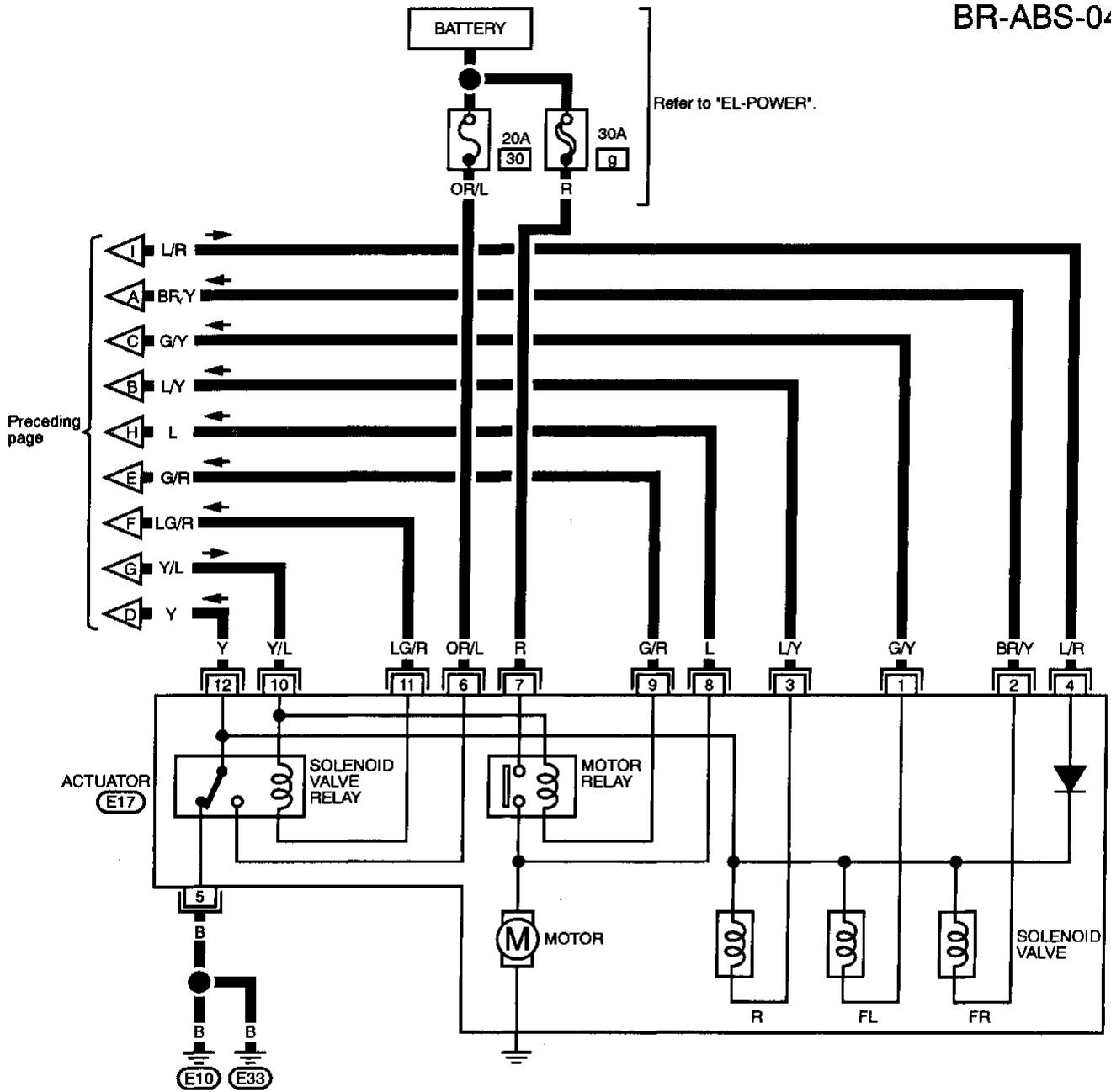

Contents

How to Perform Trouble Diagnoses for Quick and Accurate Repair	BR-31	
Self-diagnosis	BR-32	
Component Parts and Harness Connector Location	BR-35	
Preliminary Check 1	BR-36	GI
Preliminary Check 2	BR-37	
Ground Circuit Check	BR-38	
Circuit Diagram for Quick Pinpoint Check	BR-39	MA
Diagnostic Procedure 1	BR-40	
Diagnostic Procedure 2	BR-41	
Diagnostic Procedure 3	BR-44	EM
Diagnostic Procedure 4	BR-45	
Diagnostic Procedure 5	BR-47	LC
Diagnostic Procedure 6	BR-50	
Diagnostic Procedure 7	BR-52	
Diagnostic Procedure 8	BR-52	EC
Diagnostic Procedure 9	BR-52	
Electrical Component Inspection	BR-53	FE

FE
CL

MT

AT

FA

RA

BR

ST

BF

HA

EL

IDX

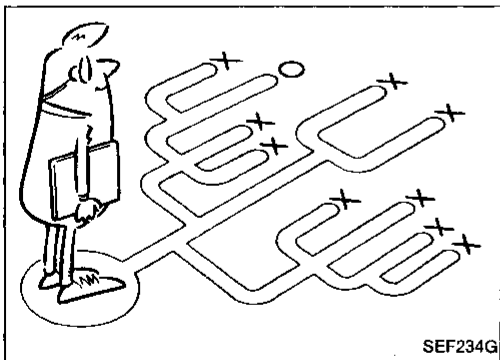
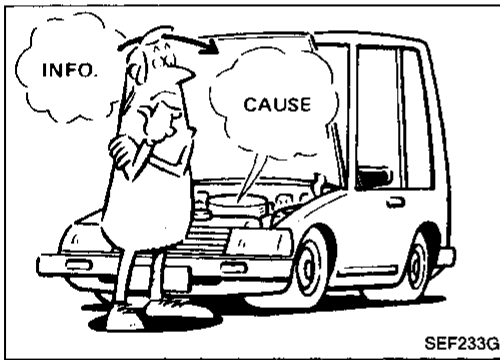

How to Perform Trouble Diagnoses for Quick and Accurate Repair

INTRODUCTION

The ABS system has an electronic control unit to control major functions. The control unit accepts input signals from sensors and instantly drives actuators. It is essential that both kinds of signals are proper and stable. It is also important to check for conventional problems: such as air leaks in the booster or lines, lack of brake fluid, or other problems with the brake system.

It is much more difficult to diagnose a problem that occurs intermittently rather than continuously. Most intermittent problems are caused by poor electric connections or faulty wiring. In this case, careful checking of suspicious circuits may help prevent the replacement of good parts.

A visual check only may not find the cause of the problems, so a road test should be performed.

Before undertaking actual checks, take just a few minutes to talk with a customer who approaches with a ABS complaint. The customer is a very good source of information on such problems; especially intermittent ones. Through the talks with the customer, find out what symptoms are present and under what conditions they occur.

Start your diagnosis by looking for "conventional" problems first. This is one of the best ways to troubleshoot brake problems on an ABS controlled vehicle.

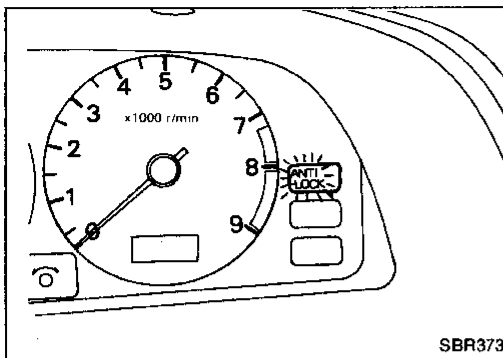

Self-diagnosis

FUNCTION

- When a problem occurs in the ABS, the warning lamp on the instrument panel comes on. To actuate the self-diagnostic results mode, ground the self-diagnostic (check) terminal located on "Data Link Connector for Consult". The location of the malfunction is indicated by the warning lamp flashing.

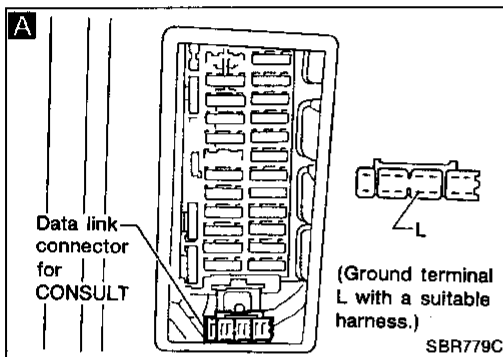

SELF-DIAGNOSIS PROCEDURE

Drive vehicle over 30 km/h (20 MPH) for at least one minute.

Turn ignition switch "OFF".

A Ground terminal "L" of "DATA LINK CONNECTOR for CONSULT" with a suitable harness.

Turn ignition switch "ON" while grounding terminal "L".
Do not depress brake pedal.

B After 3.6 seconds, the warning lamp starts flashing to indicate the malfunction code No. (See NOTE 1.)

Verify the location of the malfunction with the malfunction code chart (BR-34). Then make the necessary repairs following the diagnostic procedures.

After the malfunctions are repaired, erase the malfunction codes stored in the control unit. Refer to "HOW TO ERASE SELF-DIAGNOSTIC RESULTS" (BR-33).

Rerun the self-diagnostic results mode to verify that the malfunction codes have been erased.

C Disconnect the check terminal from the ground. The self-diagnostic results mode is now complete.

NOTE 1: The indication terminates after five minutes. However, when the Ignition switch is turned from "OFF" to "ON", the indication starts flashing again.

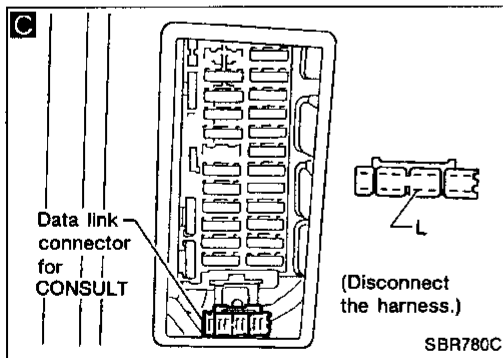
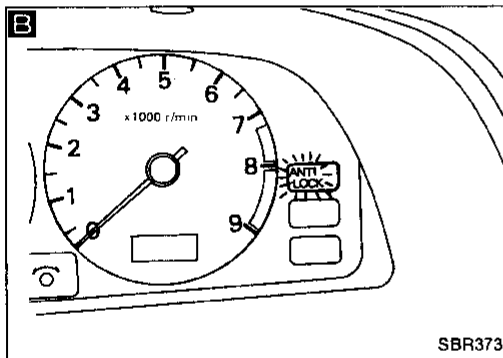

Ⓐ

TROUBLE DIAGNOSES

Self-diagnosis (Cont'd)

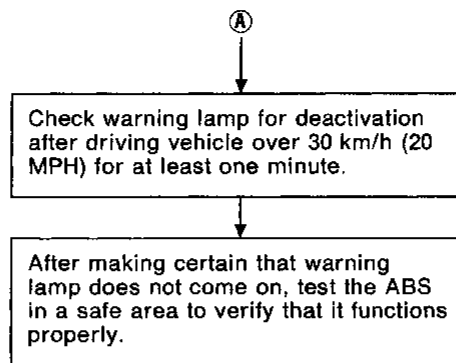

HOW TO READ SELF-DIAGNOSTIC RESULTS (Malfunction codes)

- Determine the code No. by counting the number of times the warning lamp flashes on and off.
- When several malfunctions occur at one time, up to three code numbers can be stored; the latest malfunction will be indicated first.
- The indication begins with the start code 12. After that a maximum of three code numbers appear in the order of the latest one first. The indication then returns to the start code 12 to repeat (the indication will stay on for five minutes at the most).
- The malfunction code chart is given on the next page.

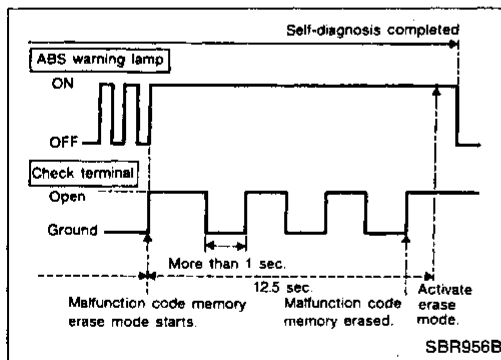
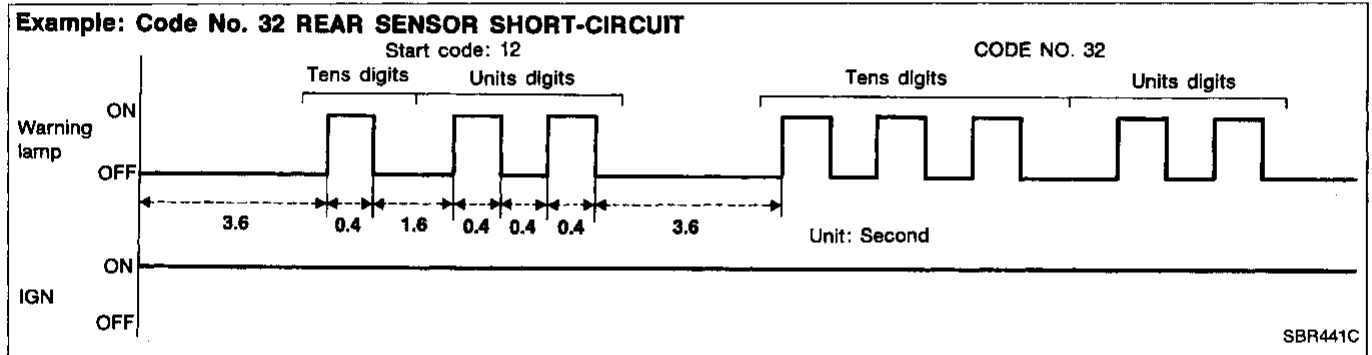

HOW TO ERASE SELF-DIAGNOSTIC RESULTS (Malfunction codes)

- Start the malfunction memory erase mode. To do so, disconnect the check terminal from the ground under the self-diagnostic results mode.
- Erase the self-diagnostic results (malfunction codes). To do so, after erase mode starts, ground check terminal more than three times within 12.5 seconds. (Each grounding must be longer than one second.)
The ABS warning lamp stays on while the erase mode. Then it goes out after the erase operation has been completed.

The self-diagnosis is also completed at the same time.

After the erase operation, rerun the self-diagnostic mode. Verify that malfunction codes no longer appear. When the system is functioning normally, only the start code should be indicated.

TROUBLE DIAGNOSES

Self-diagnosis (Cont'd)

MALFUNCTION CODE CHART

Code No.	Malfunctioning part	Diagnostic procedure
45	Front left actuator solenoid valve	3
41	Front right actuator solenoid valve	3
55	Rear actuator solenoid valve	3
25	Front left sensor (open-circuit)	4
26	Front left sensor (short-circuit)	4
21	Front right sensor (open-circuit)	4
22	Front right sensor (short-circuit)	4
35	Rear left sensor (open-circuit)	4
36	Rear left sensor (short-circuit)	4
31	Rear right sensor (open-circuit)	4
32	Rear right sensor (short-circuit)	4
18	Sensor rotor	4
61	Actuator motor or motor relay	5
63	Solenoid valve relay circuit (except power supply for relay coil)	6
57	Power supply (Low voltage)	7
16	Stop lamp switch circuit	8
71	Control unit	9
Warning lamp stays on when ignition switch is turned on.	Control unit power supply circuit Warning lamp bulb circuit Control unit or control unit connector Solenoid valve relay stuck Power supply for solenoid valve relay coil	2
Warning lamp stays on, during self-diagnosis.	Control unit	—
Warning lamp does not come on when ignition switch is turned on.	Fuse, warning lamp bulb or warning lamp circuit Control unit	1
Warning lamp does not come on during self-diagnosis.	Control unit	—

Component Parts and Harness Connector Location

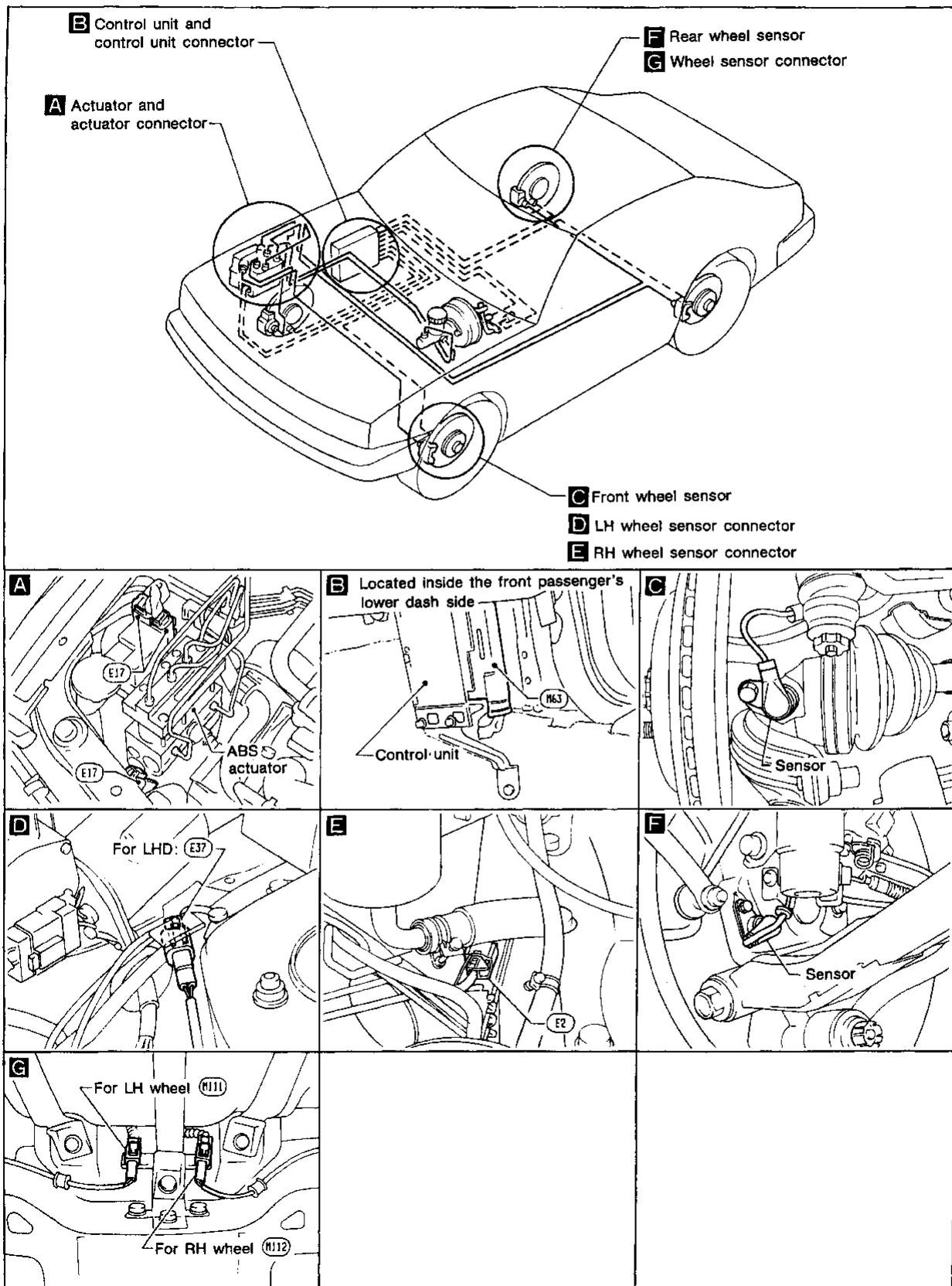

GI
MA
EM
LC
EC
FE
CL
MT
AT
FA
RA
BR
ST
BF
HA
EL
IDX

TROUBLE DIAGNOSES

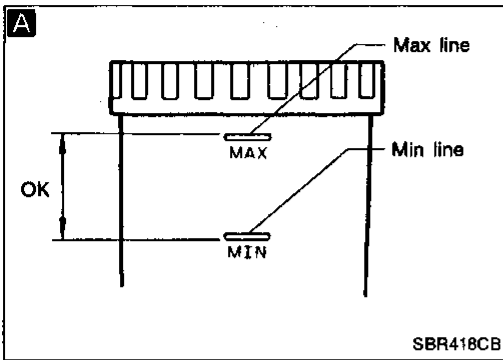

Preliminary Check 1

A
Check brake fluid level in reservoir tank.
Low fluid level may indicate brake pad wear or leakage from brake line.

B
Check brake line for leakage. NG → Repair.

C
Check brake booster for operation and air tightness. Refer to (BR-9). NG → Replace.

D
Check brake pads and rotor. Refer to (BR-11, 15). NG → Replace.

A
Check brake fluid level in reservoir tank. NG → Fill up brake fluid.

OK → END

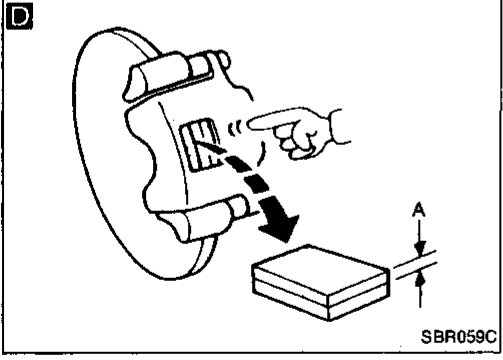
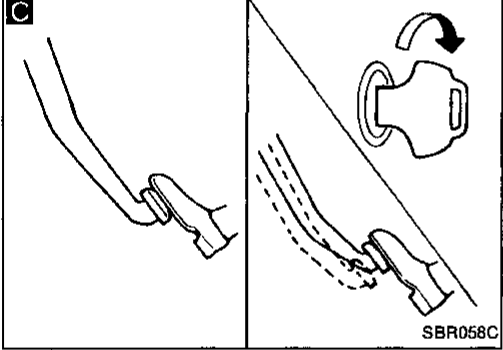
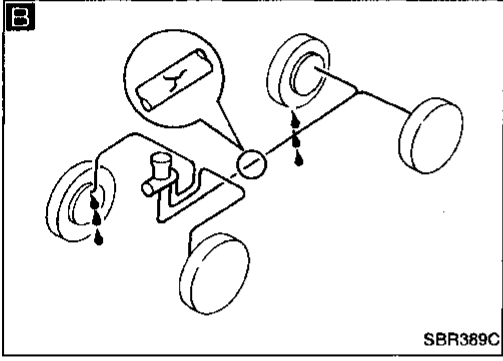

TROUBLE DIAGNOSES

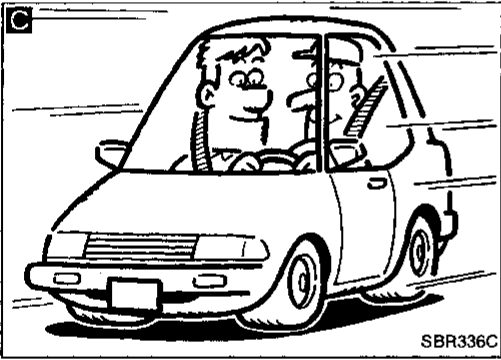
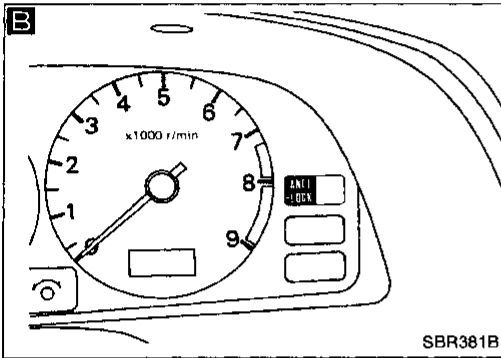
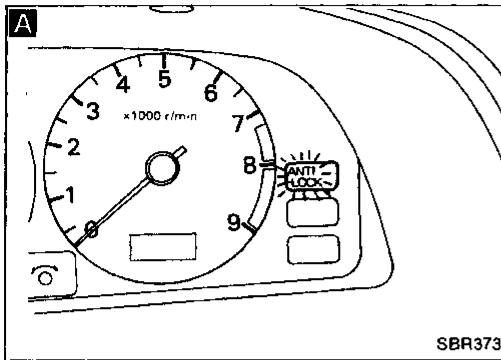

Preliminary Check 2

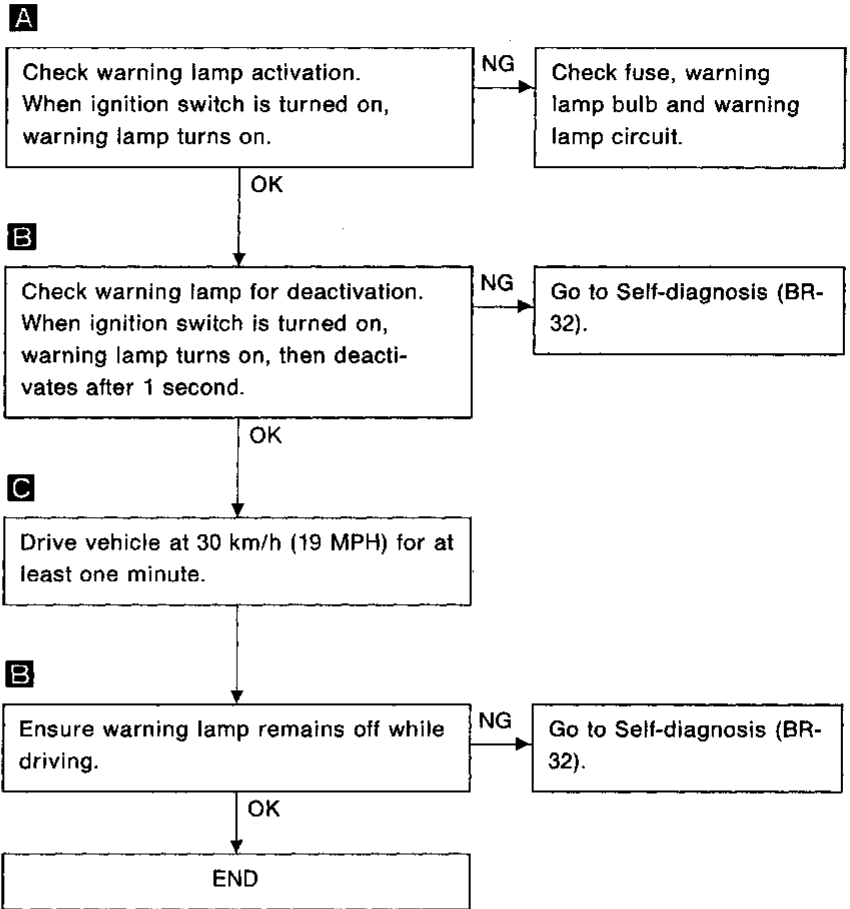

GI
 MA
 EM
 LC
 EC
 FE
 CL
 MT
 AT
 FA
 RA
BR
 ST
 BF
 HA
 EL
 IDX

TROUBLE DIAGNOSES

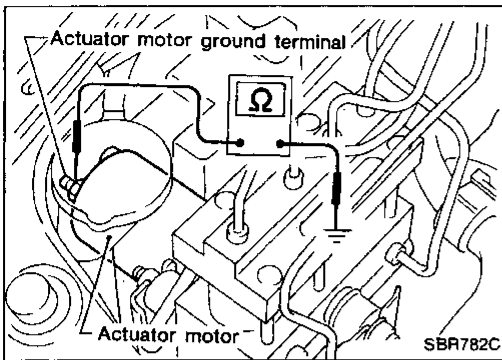

Ground Circuit Check

ACTUATOR MOTOR GROUND

- Check resistance between actuator motor ground terminal and body ground.
Resistance: 0Ω

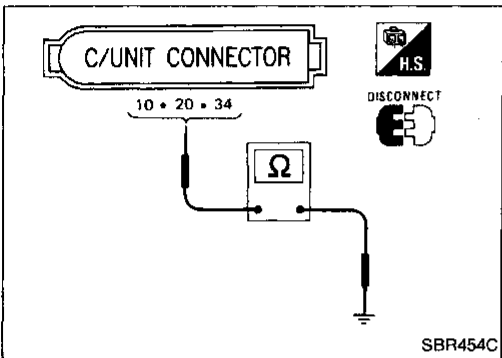

CONTROL UNIT GROUND

- Check resistance between the terminals and ground.
Resistance: 0Ω

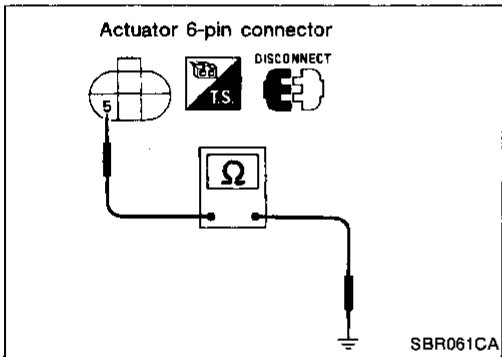

ACTUATOR GROUND

- Check resistance between actuator harness 6-pin connector terminal ⑤ and ground.
Resistance: 0Ω

Circuit Diagram for Quick Pinpoint Check

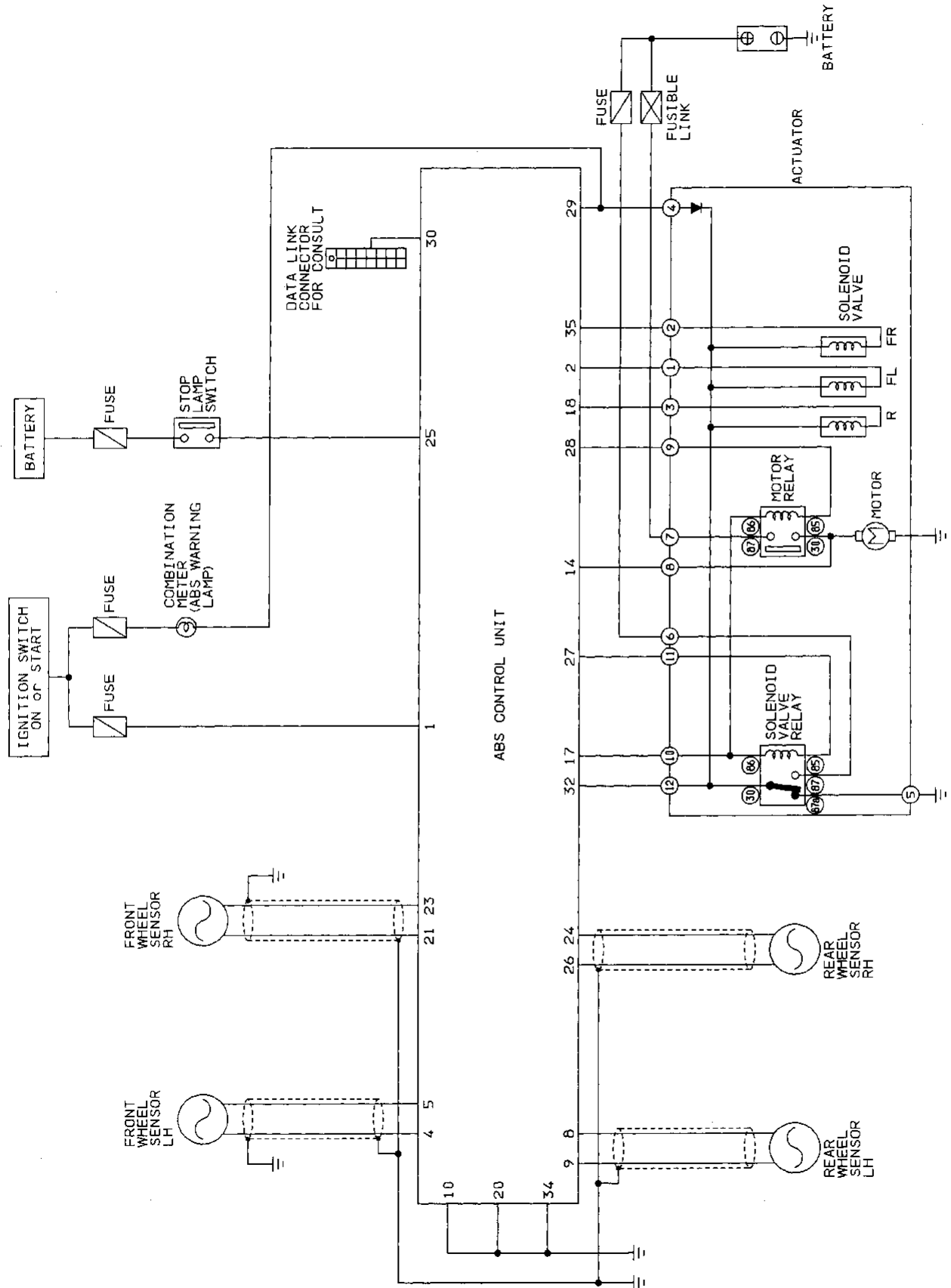

GI
MA
EM
LC
EC
FE
CL
MT
AT
FA
RA
BR
ST
BF
HA
EL
IDX

TROUBLE DIAGNOSES

Diagnostic Procedure 1 (Not self-diagnostic item)

Warning lamp does not work before engine starts.

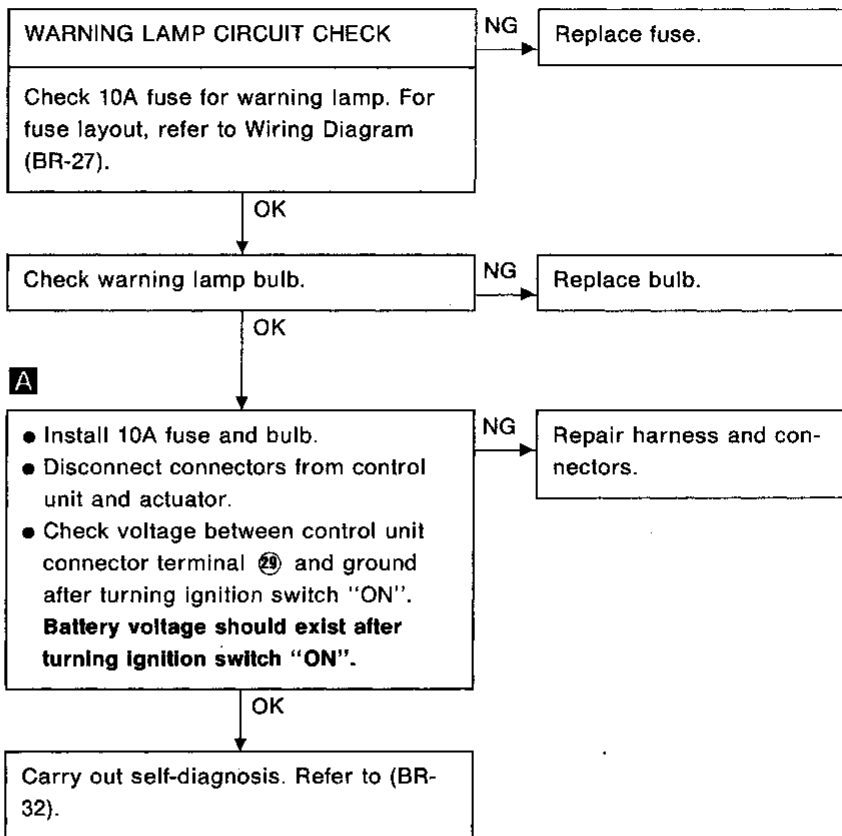
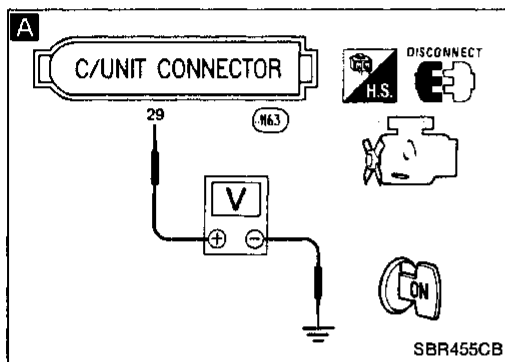

TROUBLE DIAGNOSES

Diagnostic Procedure 2 (Not Self-diagnostic item)

Warning lamp stays on continuously.

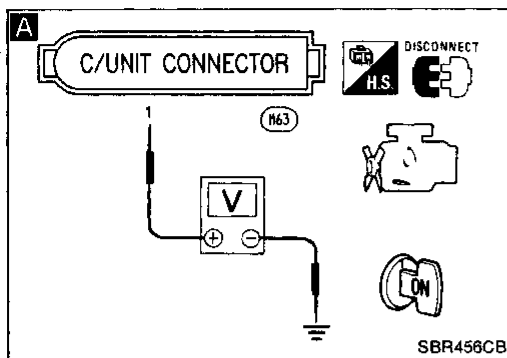

CONTROL UNIT POWER SUPPLY CIRCUIT

Check 10A fuse for control unit. For fuse layout, refer to Wiring Diagram (BR-27).

NG → ⑧

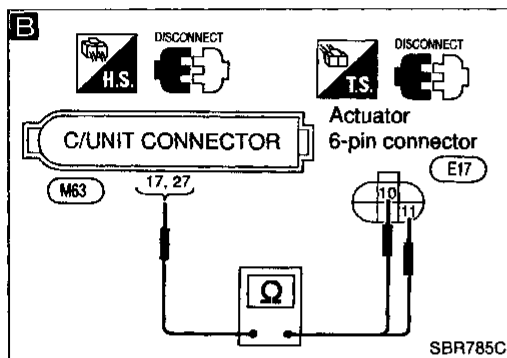

A

- Disconnect connector from control unit.
- Check voltage between control unit connector terminal ① and ground after turning ignition switch "ON". **Battery voltage should exist.**

NG → Repair harness and connector.

B

SOLENOID VALVE RELAY COIL POWER SUPPLY CIRCUIT

- Turn ignition switch "OFF". Disconnect actuator 6-pin connector.
- Check continuity between control unit connector terminals and actuator 6-pin connector (body side) terminals.

Control unit	Actuator
⑰	⑩
⑳	⑪

Continuity should exist.

NG → Repair harness and connector.

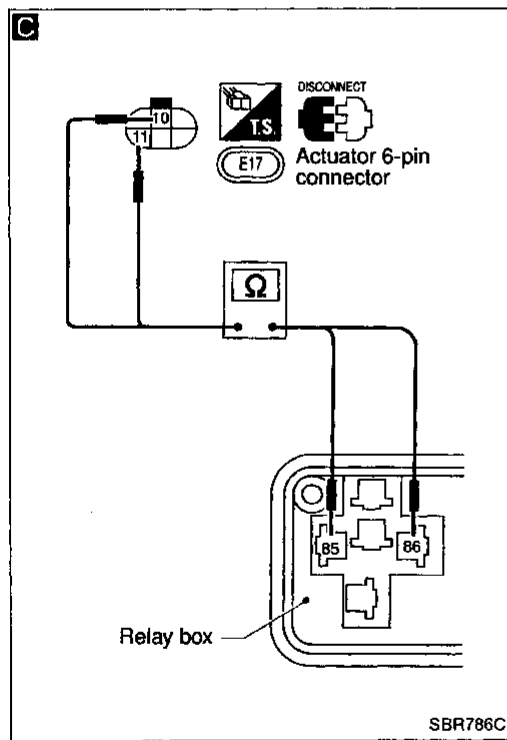

C

CIRCUIT CHECK

- Disconnect solenoid valve relay.
- Check continuity between actuator 6-pin connector (actuator side) terminals and solenoid valve relay box terminals.

Actuator	Relay box
⑩	Ⓑ
⑪	Ⓑ

Continuity should exist.

NG → Replace actuator.

SOLENOID VALVE RELAY CHECK

Refer to SOLENOID VALVE RELAY in Electrical Components Inspection (BR-53).

NG → Replace solenoid valve relay.

OK → ⑨

GI
MA
EM
LC
EC
FE
CL
MT
AT
FA
RA
BR
ST
BF
HA
EL
IDX

TROUBLE DIAGNOSES

Diagnostic Procedure 2 (Not Self-diagnostic item) (Cont'd)

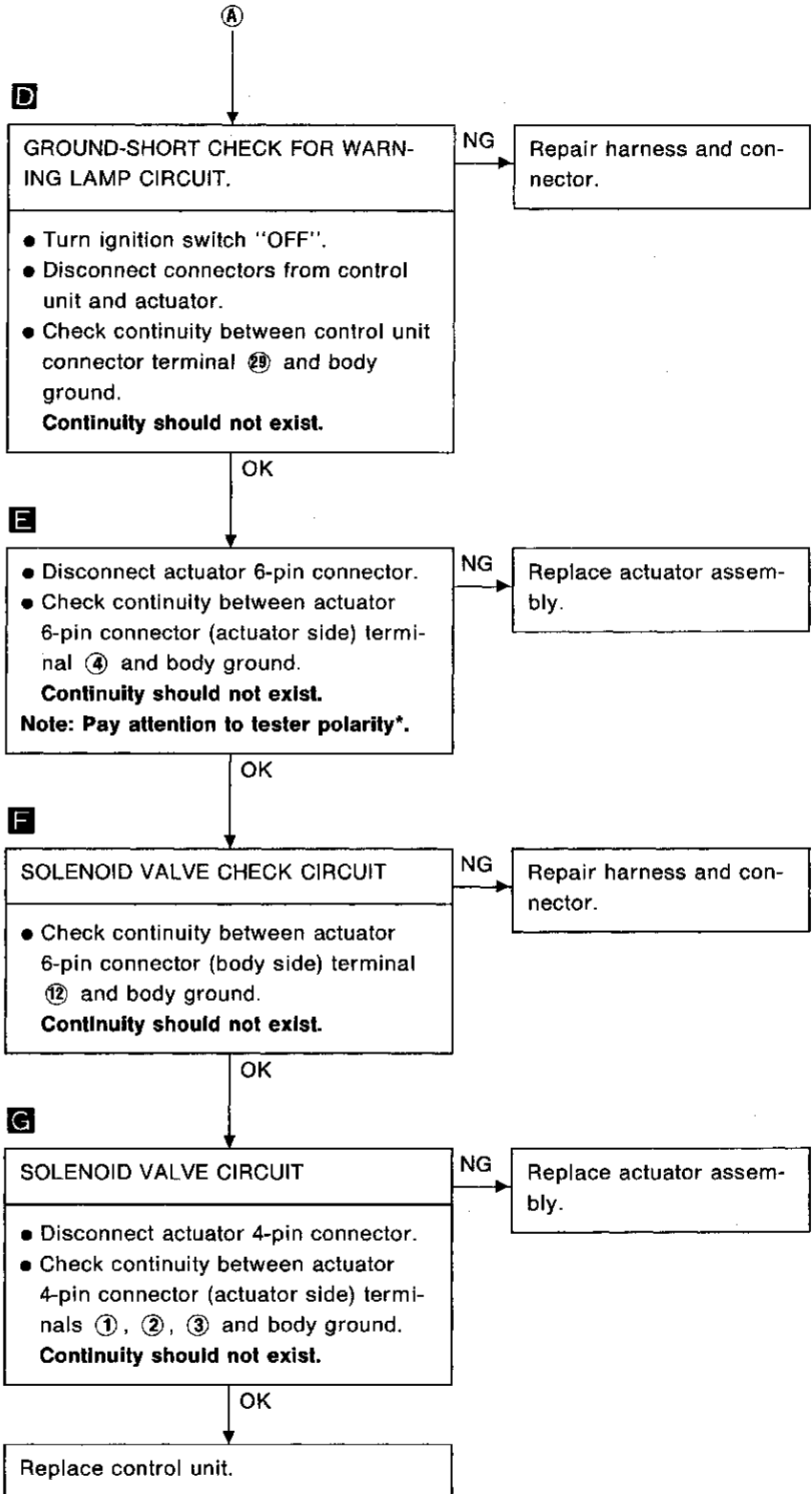
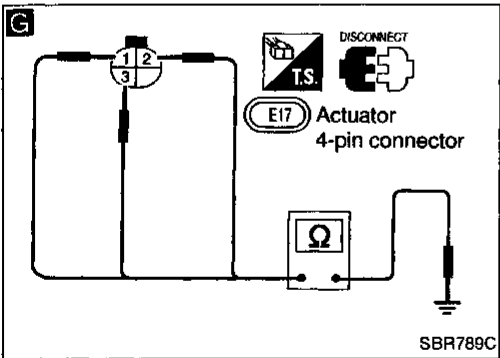
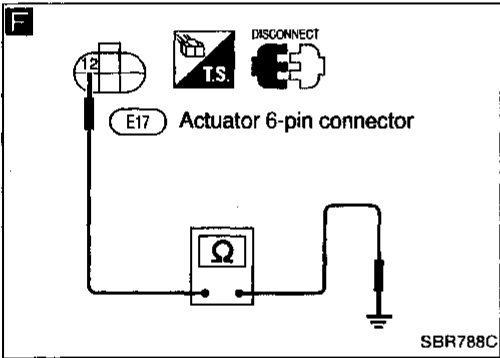
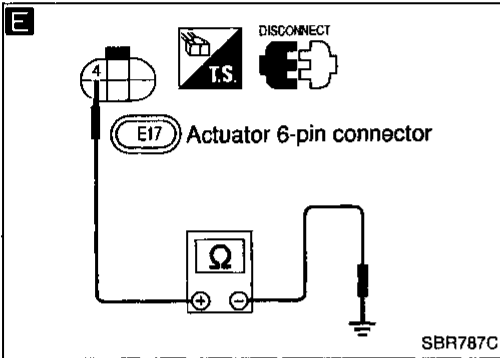
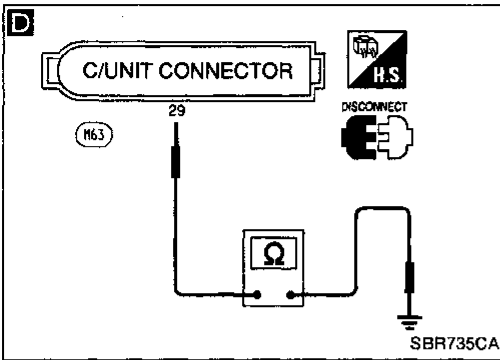

*: Specifications may vary depending on the type of tester.
Before performing this inspection, refer to the instruction manual of the tester.

TROUBLE DIAGNOSES

Diagnostic Procedure 2 (Not Self-diagnostic item) (Cont'd)

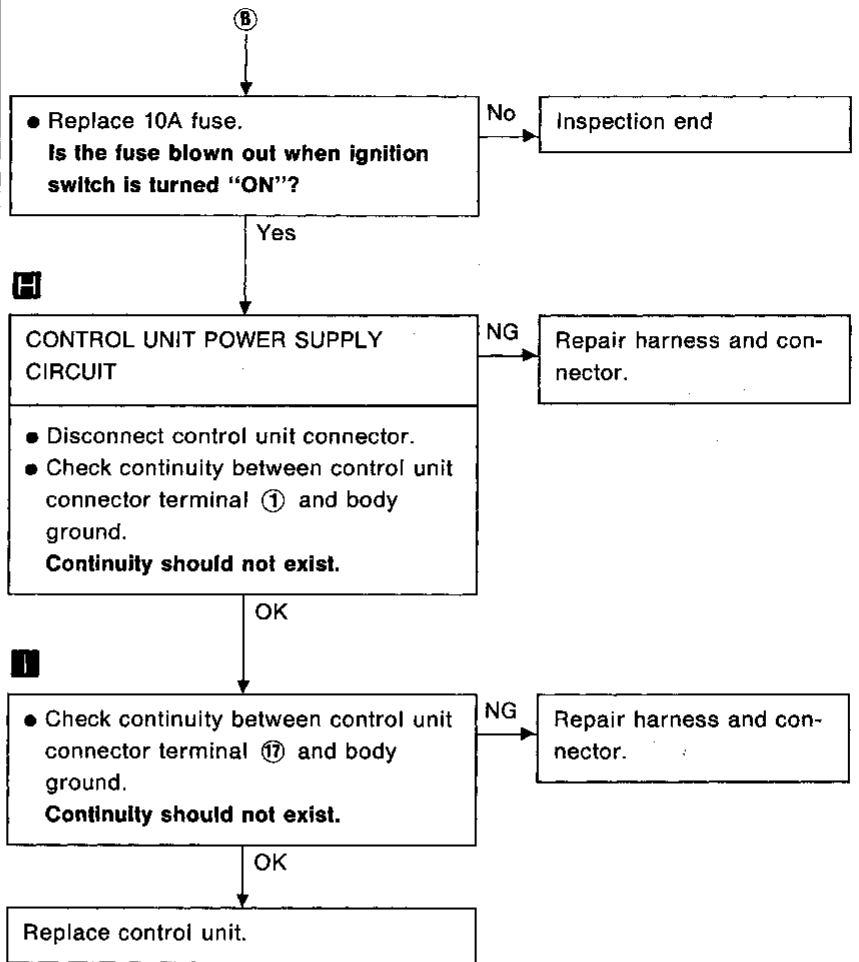
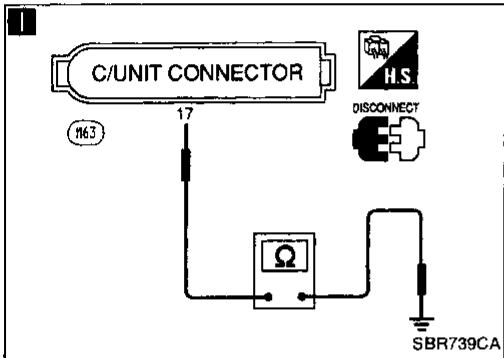
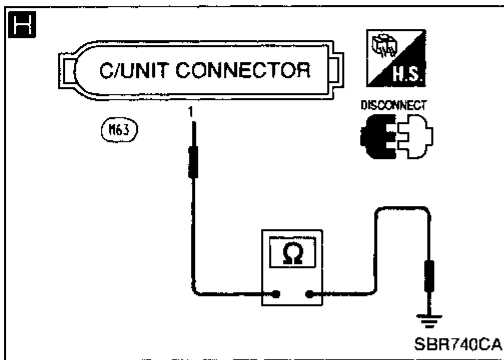

GI
MA
EM
LC
EC
FE
CL
MT
AT
FA
RA
BR
ST
BF
HA
EL
IDX

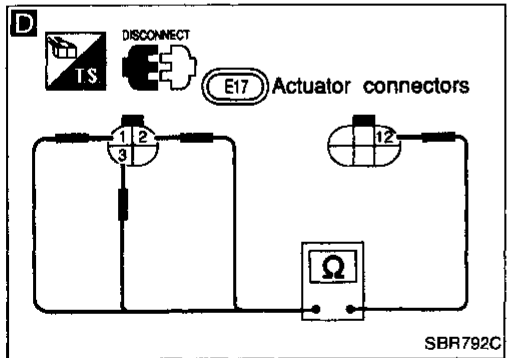
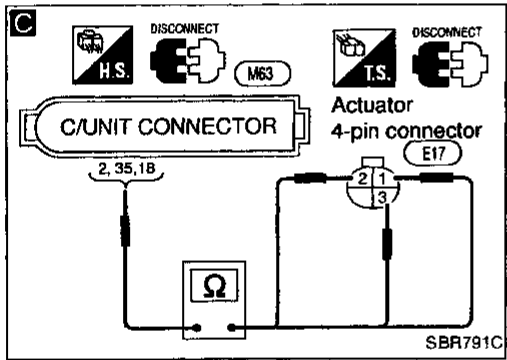
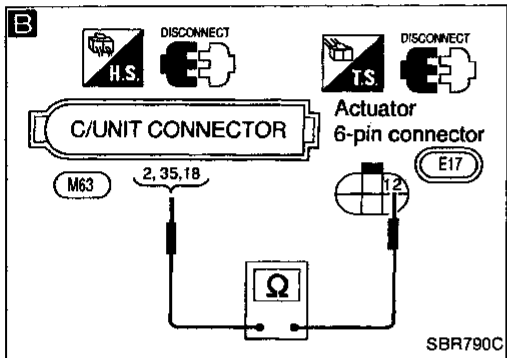
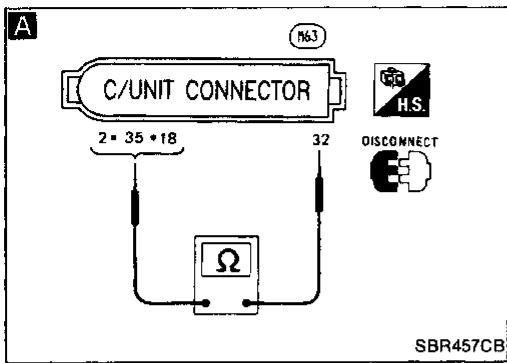

Diagnostic Procedure 3 ACTUATOR SOLENOID VALVE (Malfunction code No. 45, 41 or 55)

A

ACTUATOR SOLENOID VALVE CHECK

OK → Replace control unit.

- Disconnect control unit connector.
- Check resistance between control unit connector terminals.

Code No.	Terminals
45	⑫ - ②
41	⑫ - ③⑤
55	⑫ - ⑩

Resistance: 0.8 - 1.5Ω

NG

B

OK → Repair harness and connector between control unit connector terminal ⑫ and actuator 6-pin connector terminal ⑫.

- Disconnect actuator 6-pin connector.
- Check resistance between control unit connector terminals and actuator 6-pin connector (actuator side) terminal.

Code No.	Control unit	Actuator
45	②	⑫
41	③⑤	⑫
55	⑩	⑫

Resistance: 0.8 - 1.5Ω

NG

C

NG → Repair harness and connector.

- Disconnect actuator 4-pin connector.
- Check continuity between control unit connector terminals and actuator 4-pin connector (body side) terminals.

Code No.	Control unit	Actuator
45	②	①
41	③⑤	②
55	⑩	③

Continuity should exist.

OK

D

OK → Repair harness and connectors between actuator connector and control unit connector.

- Disconnect actuator connectors.
- Check resistance between actuator connector (actuator side) terminals.

Code No.	Terminals
45	⑫ - ①
41	⑫ - ②
55	⑫ - ③

Resistance: 0.8 - 1.5Ω

NG

Replace actuator.

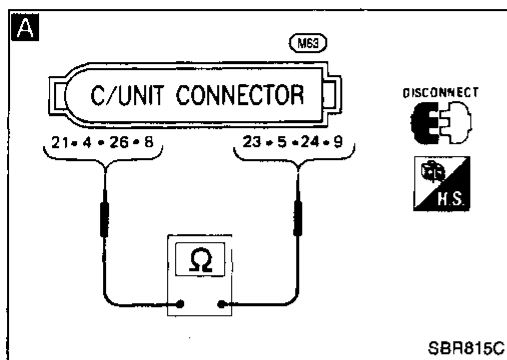

Diagnostic Procedure 4

WHEEL SENSOR OR ROTOR

(Malfunction code No. 21, 22, 25, 26, 31, 32, 35, 36 or 18)

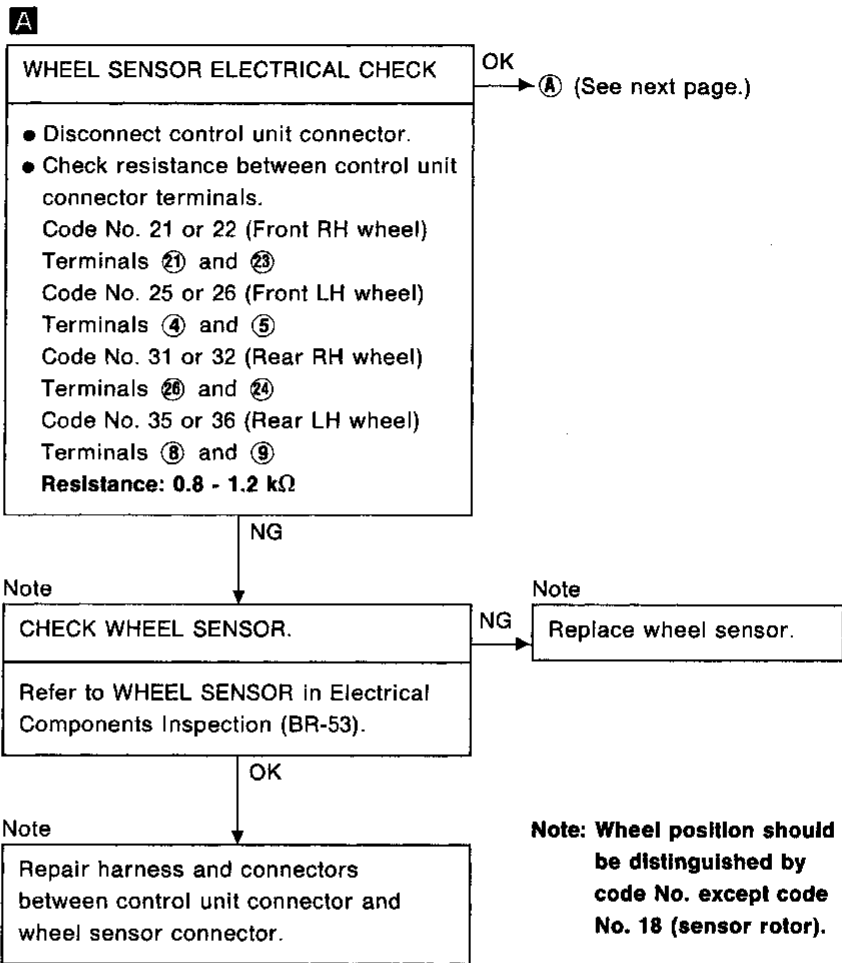

GI
MA
EM
LC
EC
FE
CL
MT
AT
FA
RA
BR
ST
BF
HA
EL
IDX

TROUBLE DIAGNOSES

Diagnostic Procedure 4 (Cont'd)

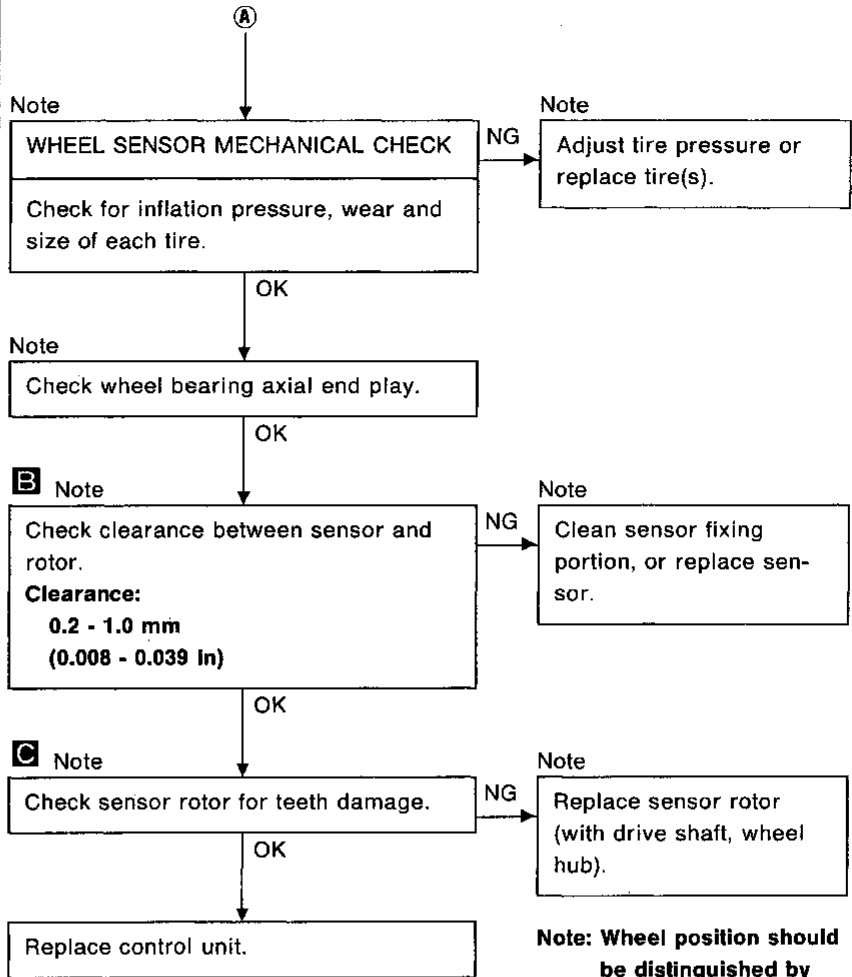
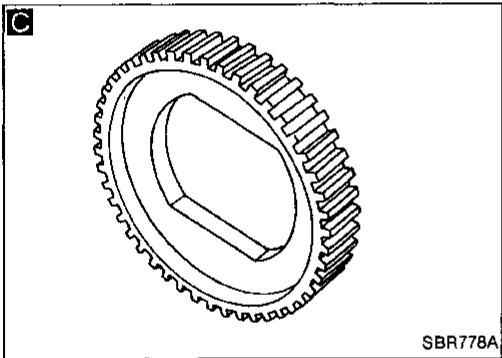
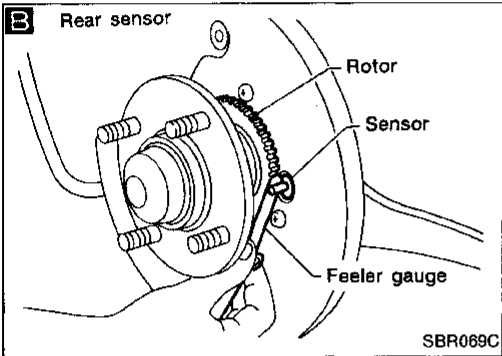
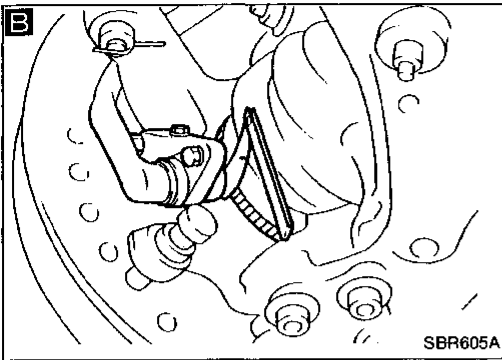

Note: Wheel position should be distinguished by code No. except code No. 18 (sensor rotor).

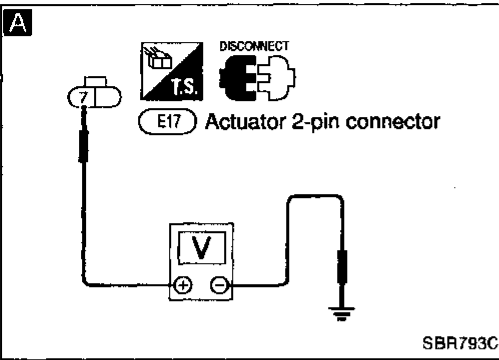

Diagnostic Procedure 5 MOTOR RELAY OR MOTOR (Malfunction code No. 61)

MOTOR POWER SUPPLY CIRCUIT NG → **B**

- Check fusible link for actuator. For fusible link layout, refer to Wiring Diagram (BR-27).

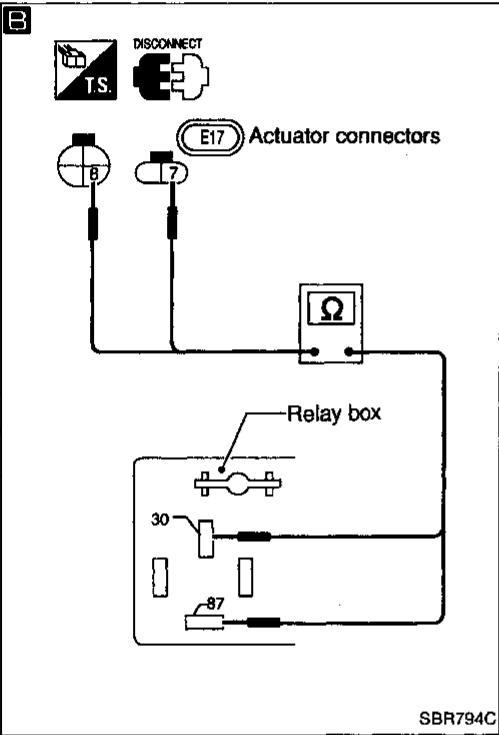

A

- Disconnect actuator 2-pin connector.
- Check voltage between connector (body side) terminal ⑦ and ground. **Battery voltage should exist.**

NG → Repair harness and connectors.

OK

B

MOTOR RELAY CIRCUIT NG → Replace actuator assembly.

- Remove motor relay.
- Disconnect actuator connectors.
- Check continuity between actuator connector (actuator side) terminals and relay connector terminals.

Actuator connector	Relay connector
⑦	⑧⑦
⑧	⑩③

Continuity should exist.

OK

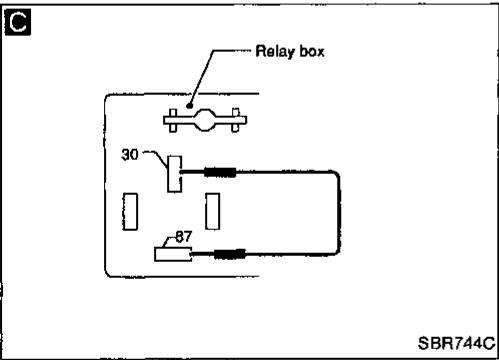

C

MOTOR CHECK NG → Replace actuator assembly.

- Connect actuator connectors.
- Connect suitable wire between relay connector terminals ⑧⑦ and ⑩③. **Motor should operate. Do not connect wire for more than 5 seconds.**

OK

MOTOR RELAY CHECK NG → Replace motor relay.

Refer to MOTOR RELAY in Electrical Components Inspection (BR-53).

OK

Ⓐ

GI
MA
EM
LC
EC
FE
CL
MT
AT
FA
RA
BR
ST
BF
HA
EL
IDX

TROUBLE DIAGNOSES

Diagnostic Procedure 5 (Cont'd)

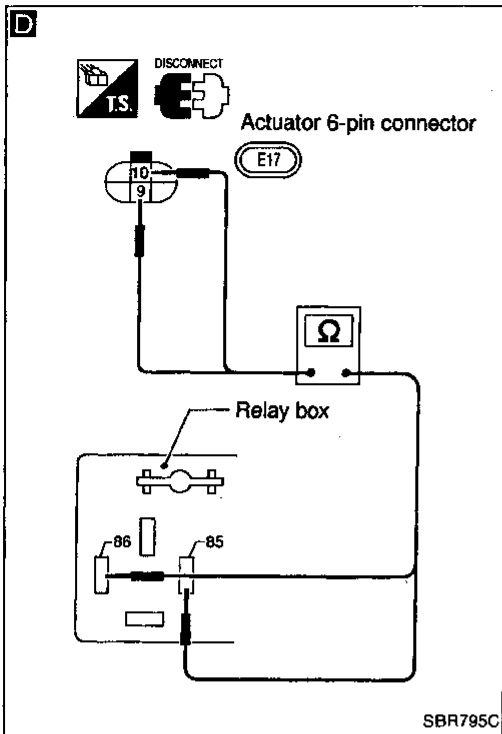

D

MOTOR RELAY CIRCUIT

NG → Replace actuator assembly.

- Disconnect actuator 6-pin connector.
- Check continuity between actuator connector (actuator side) terminals and relay connector terminals.

Actuator connector	Relay connector
⑩	⑧⑥
⑨	⑧⑤

Continuity should exist.

OK

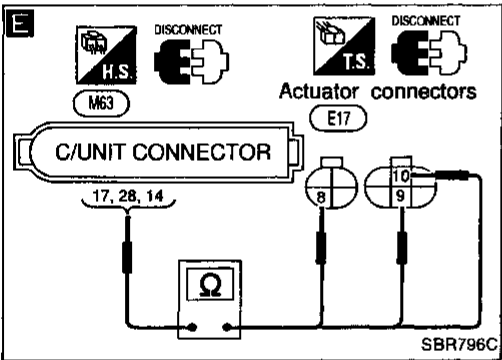

E

CIRCUIT CHECK

NG → Repair harness and connectors.

- Disconnect control unit connector.
- Check continuity between control unit connector terminals and actuator connector (body side) terminals.

Control unit	Actuator relay
⑩⑦	⑩⑩
⑩⑧	⑩⑨
⑩④	⑩⑧

Continuity should exist.

OK

Replace control unit.

NG → Repair harness and connectors.

TROUBLE DIAGNOSES

Diagnostic Procedure 5 (Cont'd)

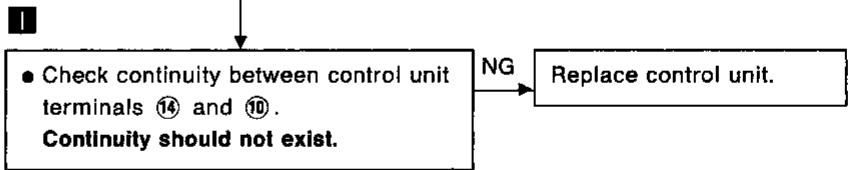
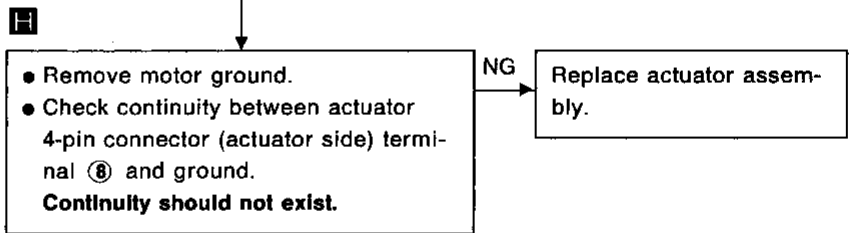
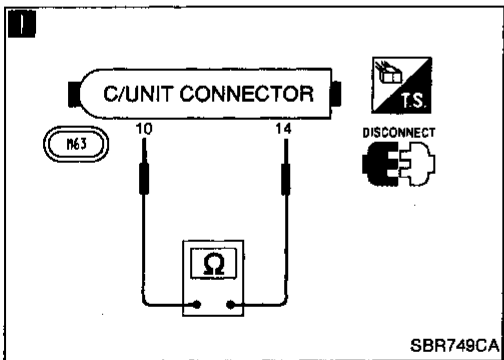
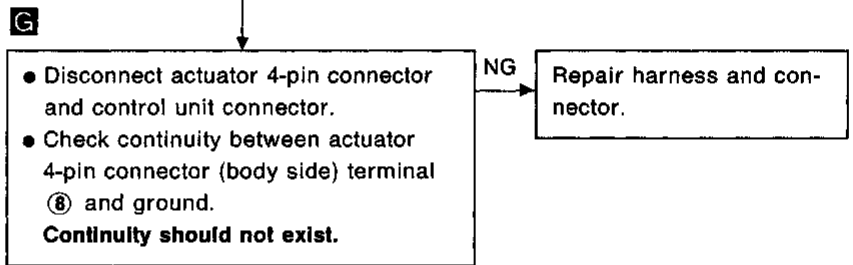
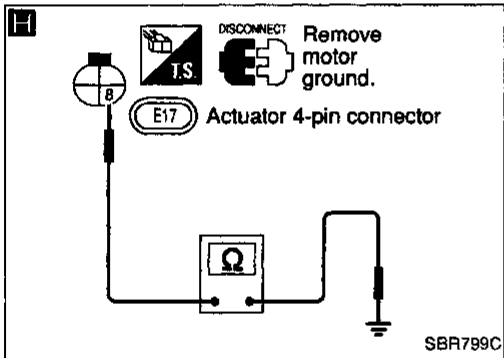
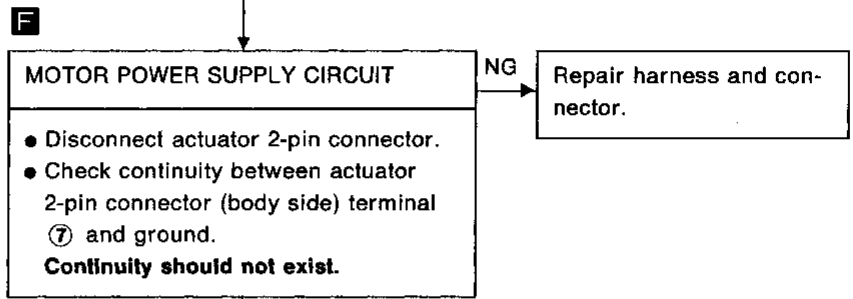
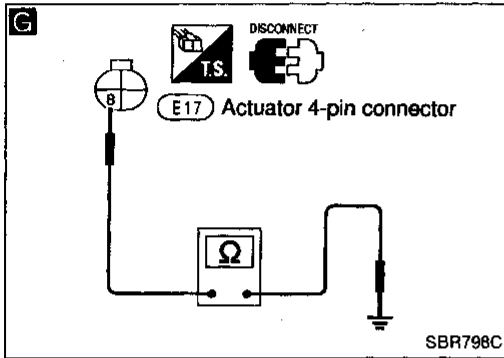
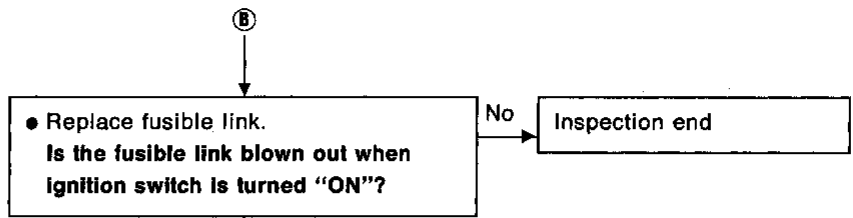
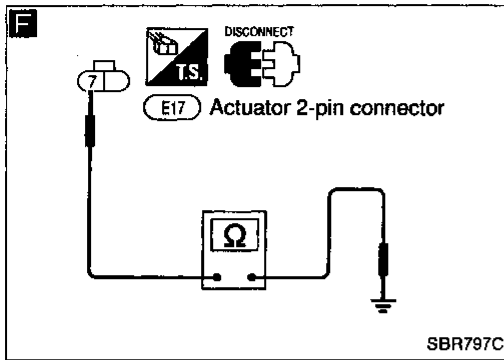

Replace actuator assembly.

GI
 MA
 EM
 LC
 EC
 FE
 CL
 MT
 AT
 FA
 RA
 BR
 ST
 BF
 HA
 EL
 IDX

Diagnostic Procedure 6 SOLENOID VALVE RELAY (Malfunction code No. 63)

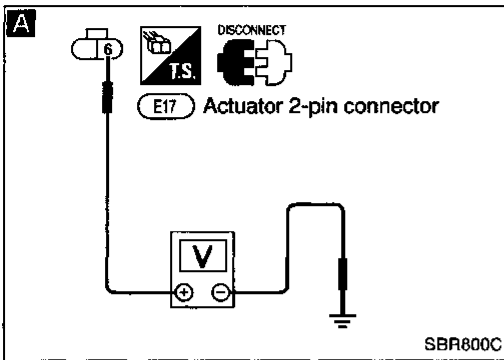

SOLENOID VALVE POWER SUPPLY CHECK

NG → (See next page.)

- Check 20A fuse. For fuse layout, refer to Wiring Diagram (BR-27).

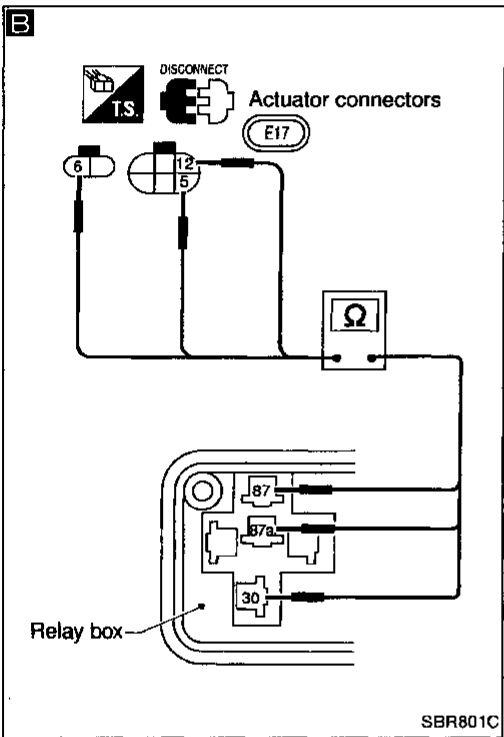

A
SOLENOID VALVE POWER SUPPLY CHECK

NG → Repair harness and connector.

- Disconnect connectors from actuator.
- Check voltage between actuator 2-pin connector (body side) terminal ⑥ and ground.

Battery voltage should exist.

SOLENOID VALVE RELAY CHECK

NG → Replace solenoid valve relay.

Refer to SOLENOID VALVE RELAY in Electrical Components Inspection (BR-53).

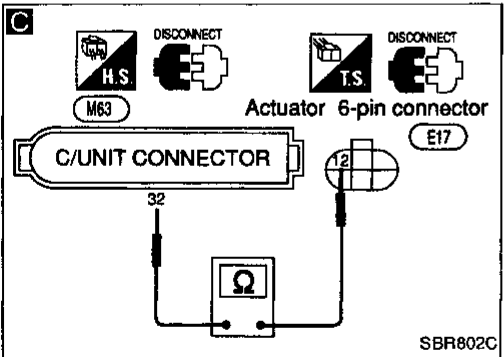

B
SOLENOID VALVE RELAY CIRCUIT CHECK

NG → Replace actuator.

Check continuity between relay terminals and actuator connector (actuator side) terminals.

Relay terminals	Connector terminals
30	12
87	6
87a	5

Continuity should exist.

C
CIRCUIT CHECK

NG → Repair harness and connectors.

- Disconnect control unit connector.
- Check continuity between control unit connector terminal ⑫ and actuator connector (body side) terminal ⑫.

Continuity should exist.

OK → Replace control unit.

TROUBLE DIAGNOSES

Diagnostic Procedure 6 (Cont'd)

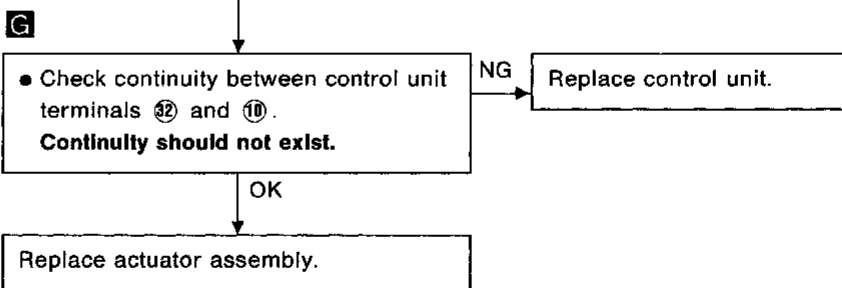
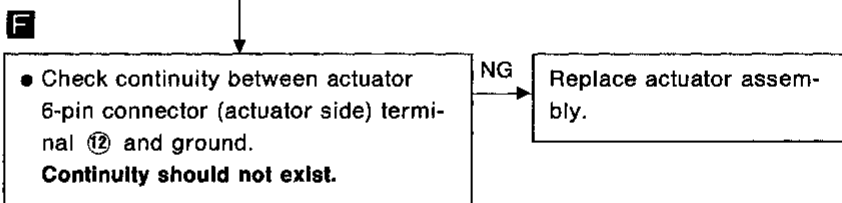
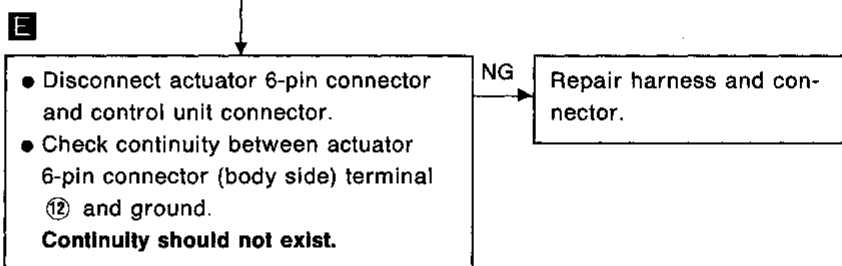
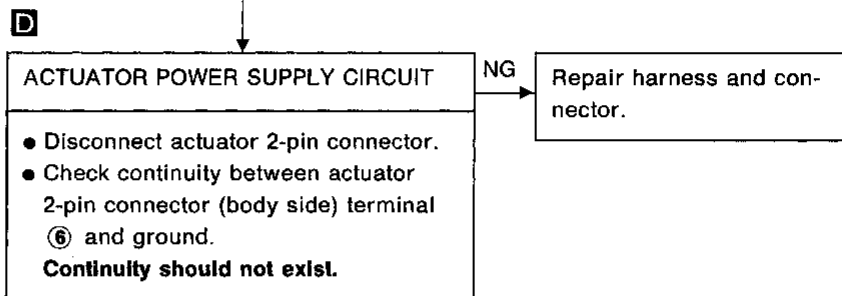
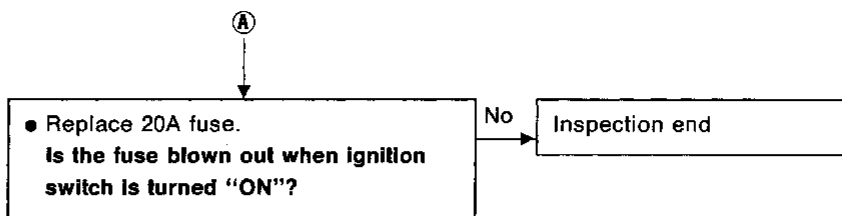
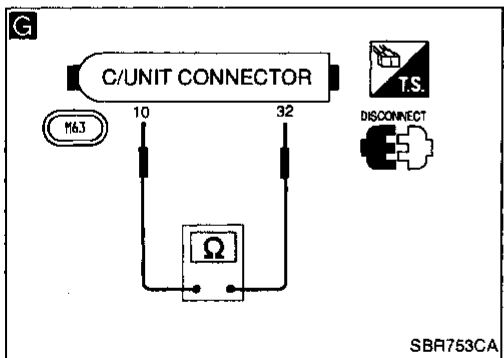
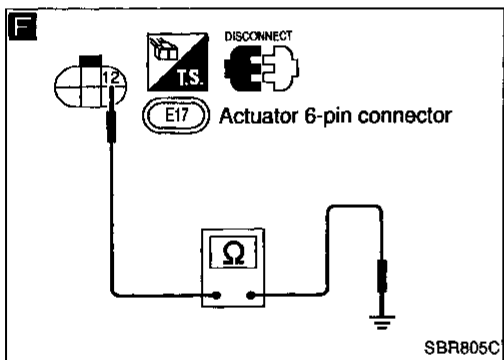
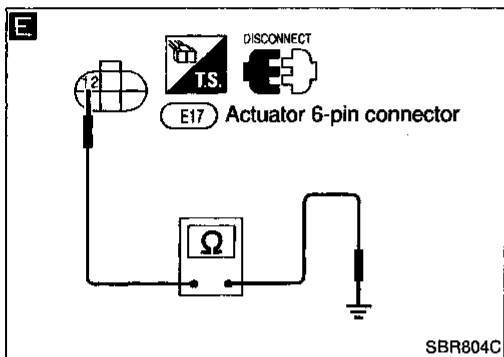
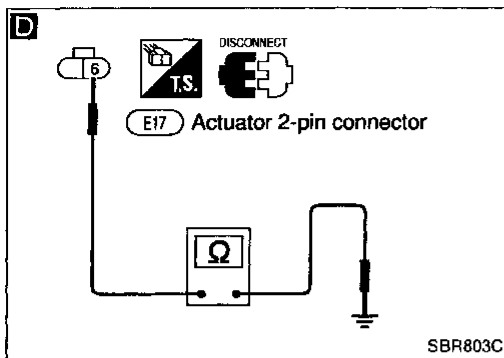

GI

MA

EM

LC

EC

FE

CL

MT

AT

FA

RA

BR

ST

BF

HA

EL

IDX

TROUBLE DIAGNOSES

Diagnostic Procedure 7

POWER SUPPLY (Low voltage) (Malfunction code No. 57)

BATTERY CHECK

Check battery.

Diagnostic Procedure 8

STOP LAMP SWITCH CIRCUIT (Malfunction code No. 16)

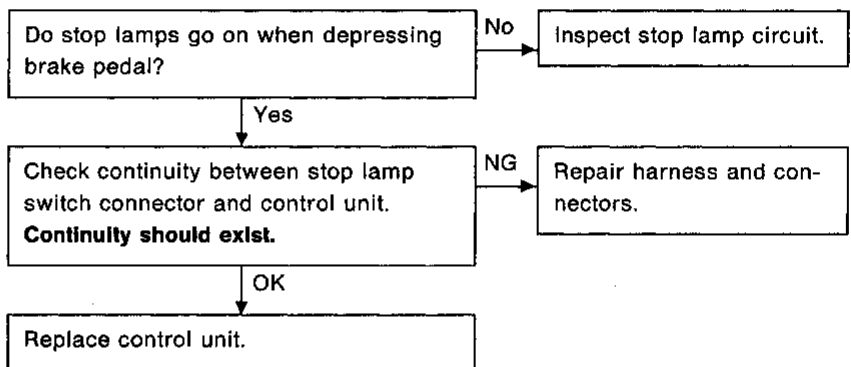

Diagnostic Procedure 9

CONTROL UNIT (Malfunction code No. 71)

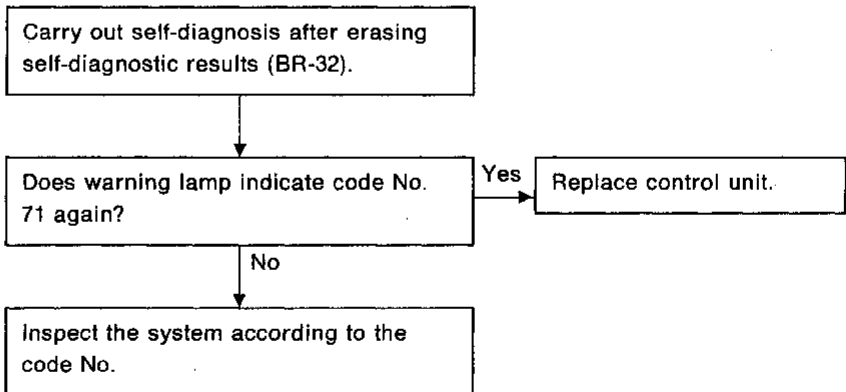

Electrical Components Inspection

WHEEL SENSOR

Check resistance for each sensor.
Resistance: 0.8 - 1.2 kΩ

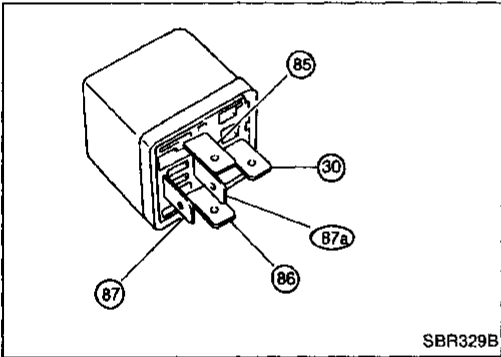
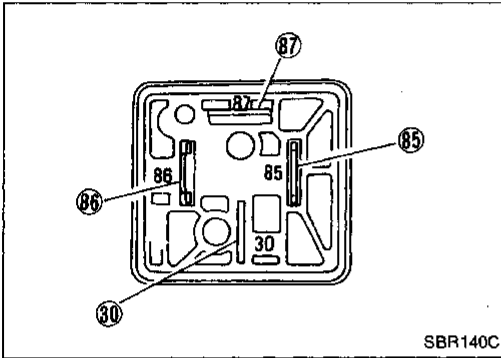
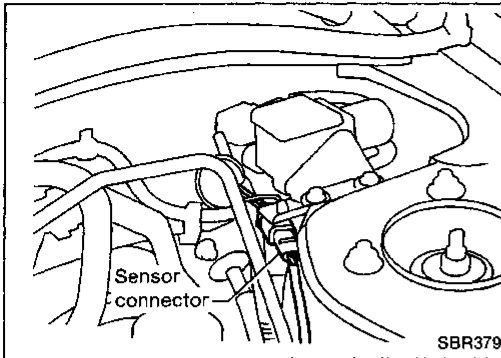

ACTUATOR MOTOR RELAY

Condition	Continuity existence between terminals ⑧⑤ and ⑧⑦
Battery voltage not applied between terminals ⑧⑤ and ⑧⑥.	No
Battery voltage applied between terminals ⑧⑤ and ⑧⑥.	Yes

SOLENOID VALVE RELAY

Condition	Continuity existence between terminals ⑧⑩ and ⑧⑦a	Continuity existence between terminals ⑧⑩ and ⑧⑦
Battery voltage not applied between terminals ⑧⑤ and ⑧⑥.	Yes	No
Battery voltage applied between terminals ⑧⑤ and ⑧⑥.	No	Yes

GI

MA

EM

LC

EC

FE

CL

MT

AT

FA

RA

BR

ST

BF

HA

EL

IDX

SERVICE DATA AND SPECIFICATIONS (SDS)

General Specifications

Front brake	
Brake model	CL25VA disc brake
Cylinder bore diameter mm (in)	57.2 (2.252)
Pad mm (in) Length x width x thickness	125.6 x 46.0 x 11 (4.94 x 1.811 x 0.43)
Rotor outer diameter x thickness mm (in)	257 x 22 (10.12 x 0.87)
Rear brake	
Brake model	CL9HA disc brake
Cylinder bore diameter mm (in)	33.96 (1.3370)
Pad mm (in) Length x width x thickness	89.1 x 39.5 x 10 (3.508 x 1.555 x 0.39)
Rotor outer diameter x thickness mm (in)	258 x 9 (10.16 x 0.35)

Master cylinder	
Cylinder bore diameter mm (in)	23.81 (15/16)
Control valve	
Valve model	Dual proportioning valve
Split point kPa (kg/cm ² , psi) x reducing ratio	2,452 (25, 356) x 0.4
Brake booster	
Booster model	M195T
Diaphragm diameter mm (in)	Primary: 205 (8.07) Secondary: 180 (7.09)
Recommended brake fluid	DOT 3

Inspection and Adjustment

DISC BRAKE

Brake model	CL25VA	CL9HA
Pad wear limit mm (in)		
Minimum thickness	2.0 (0.079)	1.5 (0.059)
Rotor repair limit mm (in)		
Minimum thickness	20.0 (0.787)	8 (0.31)

PARKING BRAKE

Type	Center lever
Number of notches [under force of 196 N (20 kg, 44 lb)]	6 - 8
Number of notches when warning lamp switch comes on	1

BRAKE PEDAL

Free height "H" mm (in)	
M/T	151 - 161 (5.94 - 6.34)
A/T	159 - 169 (6.26 - 6.65)
Depressed height "D" mm (in)	
[under force of 490 N (50 kg, 110 lb) with engine running]	M/T: 80 (3.15) A/T: 85 (3.35)
Pedal free play "A" mm (in)	1 - 3 (0.04 - 0.12)
Clearance "C" between pedal stopper and threaded end of stop lamp switch or ASCD switch mm (in)	0.3 - 1.0 (0.012 - 0.039)