

A  
B  
AT  
D  
E  
F  
G  
H  
I  
J  
K  
L  
M  
N  
O  
P

# SECTION **AT**

## AUTOMATIC TRANSMISSION

### CONTENTS

<p><b>SERVICE INFORMATION ..... 5</b></p> <p><b>INDEX FOR DTC ..... 5</b></p> <p style="padding-left: 20px;">Alphabetical Index .....5</p> <p style="padding-left: 20px;">DTC No. Index .....5</p> <p><b>PRECAUTIONS ..... 7</b></p> <p style="padding-left: 20px;">Precaution for Supplemental Restraint System (SRS) "AIR BAG" and "SEAT BELT PRE-TENSIONER" .....7</p> <p style="padding-left: 20px;">Precaution for On Board Diagnosis (OBD) System of A/T and Engine .....7</p> <p style="padding-left: 20px;">Precaution .....7</p> <p style="padding-left: 20px;">Service Notice or Precaution .....8</p> <p><b>PREPARATION ..... 9</b></p> <p style="padding-left: 20px;">Special Service Tool .....9</p> <p style="padding-left: 20px;">Commercial Service Tool .....9</p> <p><b>A/T FLUID .....11</b></p> <p style="padding-left: 20px;">Changing A/T Fluid ..... 11</p> <p style="padding-left: 20px;">Checking A/T Fluid ..... 11</p> <p style="padding-left: 20px;">A/T Fluid Cooler Cleaning ..... 13</p> <p><b>A/T CONTROL SYSTEM .....16</b></p> <p style="padding-left: 20px;">Cross-Sectional View (2WD Models) ..... 16</p> <p style="padding-left: 20px;">Cross-Sectional View (VQ35DE Models for AWD)... 17</p> <p style="padding-left: 20px;">Cross-Sectional View (VK45DE Models for AWD)... 18</p> <p style="padding-left: 20px;">Shift Mechanism ..... 18</p> <p style="padding-left: 20px;">TCM Function ..... 29</p> <p style="padding-left: 20px;">CAN Communication ..... 30</p> <p style="padding-left: 20px;">Input/Output Signal of TCM ..... 31</p> <p style="padding-left: 20px;">Line Pressure Control ..... 31</p> <p style="padding-left: 20px;">Shift Control ..... 33</p> <p style="padding-left: 20px;">Lock-up Control ..... 34</p> <p style="padding-left: 20px;">Engine Brake Control ..... 35</p> <p style="padding-left: 20px;">Control Valve ..... 36</p> <p><b>ON BOARD DIAGNOSTIC (OBD) SYSTEM .....38</b></p> <p style="padding-left: 20px;">Introduction ..... 38</p> <p style="padding-left: 20px;">OBD-II Function for A/T System ..... 38</p> <p style="padding-left: 20px;">One or Two Trip Detection Logic of OBD-II ..... 38</p>	<p style="padding-left: 20px;">OBD-II Diagnostic Trouble Code (DTC) .....38</p> <p style="padding-left: 20px;">Malfunction Indicator Lamp (MIL) .....40</p> <p><b>TROUBLE DIAGNOSIS .....41</b></p> <p style="padding-left: 20px;">DTC Inspection Priority Chart .....41</p> <p style="padding-left: 20px;">Fail-Safe .....41</p> <p style="padding-left: 20px;">How to Perform Trouble Diagnosis for Quick and Accurate Repair .....42</p> <p style="padding-left: 20px;">A/T Electrical Parts Location .....48</p> <p style="padding-left: 20px;">Circuit Diagram .....49</p> <p style="padding-left: 20px;">Inspections Before Trouble Diagnosis .....49</p> <p style="padding-left: 20px;">Road Test .....53</p> <p style="padding-left: 20px;">Vehicle Speed at Which Gear Shifting Occurs .....58</p> <p style="padding-left: 20px;">Vehicle Speed at Which Lock-up Occurs/Releases .....58</p> <p style="padding-left: 20px;">Symptom Chart .....59</p> <p style="padding-left: 20px;">TCM Input/Output Signal Reference Value .....83</p> <p style="padding-left: 20px;">CONSULT-III Function (TRANSMISSION) .....84</p> <p style="padding-left: 20px;">Diagnosis Procedure without CONSULT-III .....91</p> <p><b>DTC U1000 CAN COMMUNICATION LINE .....94</b></p> <p style="padding-left: 20px;">Description .....94</p> <p style="padding-left: 20px;">On Board Diagnosis Logic .....94</p> <p style="padding-left: 20px;">Possible Cause .....94</p> <p style="padding-left: 20px;">DTC Confirmation Procedure .....94</p> <p style="padding-left: 20px;">Wiring Diagram - AT - CAN .....95</p> <p style="padding-left: 20px;">Diagnosis Procedure .....96</p> <p><b>DTC P0615 START SIGNAL CIRCUIT .....97</b></p> <p style="padding-left: 20px;">Description .....97</p> <p style="padding-left: 20px;">CONSULT-III Reference Value in Data Monitor Mode .....97</p> <p style="padding-left: 20px;">On Board Diagnosis Logic .....97</p> <p style="padding-left: 20px;">Possible Cause .....97</p> <p style="padding-left: 20px;">DTC Confirmation Procedure .....97</p> <p style="padding-left: 20px;">Wiring Diagram - AT - STSIG .....98</p> <p style="padding-left: 20px;">Diagnosis Procedure .....99</p> <p><b>DTC P0700 TCM ..... 101</b></p> <p style="padding-left: 20px;">Description ..... 101</p> <p style="padding-left: 20px;">On Board Diagnosis Logic ..... 101</p>
--	--

Possible Cause .....	101	<b>DTC P0733 A/T 3RD GEAR FUNCTION .....</b>	<b>118</b>
DTC Confirmation Procedure .....	101	Description .....	118
Diagnosis Procedure .....	101	On Board Diagnosis Logic .....	118
<b>DTC P0705 PARK/NEUTRAL POSITION SWITCH .....</b>	<b>102</b>	Possible Cause .....	118
Description .....	102	DTC Confirmation Procedure .....	118
CONSULT-III Reference Value in Data Monitor		Diagnosis Procedure .....	119
Mode .....	102	<b>DTC P0734 A/T 4TH GEAR FUNCTION .....</b>	<b>120</b>
On Board Diagnosis Logic .....	102	Description .....	120
Possible Cause .....	102	On Board Diagnosis Logic .....	120
DTC Confirmation Procedure .....	102	Possible Cause .....	120
Wiring Diagram - AT - PNP/SW .....	103	DTC Confirmation Procedure .....	120
Diagnosis Procedure .....	103	Diagnosis Procedure .....	121
<b>DTC P0717 TURBINE REVOLUTION SENSOR .....</b>	<b>106</b>	<b>DTC P0735 A/T 5TH GEAR FUNCTION .....</b>	<b>122</b>
Description .....	106	Description .....	122
CONSULT-III Reference Value in Data Monitor		On Board Diagnosis Logic .....	122
Mode .....	106	Possible Cause .....	122
On Board Diagnosis Logic .....	106	DTC Confirmation Procedure .....	122
Possible Cause .....	106	Diagnosis Procedure .....	123
DTC Confirmation Procedure .....	106	<b>DTC P0740 TORQUE CONVERTER CLUTCH SOLENOID VALVE .....</b>	<b>124</b>
Diagnosis Procedure .....	106	Description .....	124
<b>DTC P0720 VEHICLE SPEED SENSOR A/T (REVOLUTION SENSOR) .....</b>	<b>108</b>	CONSULT-III Reference Value in Data Monitor	
Description .....	108	Mode .....	124
CONSULT-III Reference Value in Data Monitor		On Board Diagnosis Logic .....	124
Mode .....	108	Possible Cause .....	124
On Board Diagnosis Logic .....	108	DTC Confirmation Procedure .....	124
Possible Cause .....	108	Diagnosis Procedure .....	124
DTC Confirmation Procedure .....	108	<b>DTC P0744 A/T TCC S/V FUNCTION (LOCK-UP) .....</b>	<b>126</b>
Wiring Diagram - AT - VSSA/T .....	109	Description .....	126
Diagnosis Procedure .....	110	CONSULT-III Reference Value in Data Monitor	
<b>DTC P0725 ENGINE SPEED SIGNAL .....</b>	<b>112</b>	Mode .....	126
Description .....	112	On Board Diagnosis Logic .....	126
CONSULT-III Reference Value in Data Monitor		Possible Cause .....	126
Mode .....	112	DTC Confirmation Procedure .....	126
On Board Diagnosis Logic .....	112	Diagnosis Procedure .....	126
Possible Cause .....	112	<b>DTC P0745 LINE PRESSURE SOLENOID VALVE .....</b>	<b>128</b>
DTC Confirmation Procedure .....	112	Description .....	128
Diagnosis Procedure .....	112	CONSULT-III Reference Value in Data Monitor	
<b>DTC P0731 A/T 1ST GEAR FUNCTION .....</b>	<b>114</b>	Mode .....	128
Description .....	114	On Board Diagnosis Logic .....	128
On Board Diagnosis Logic .....	114	Possible Cause .....	128
Possible Cause .....	114	DTC Confirmation Procedure .....	128
DTC Confirmation Procedure .....	114	Diagnosis Procedure .....	128
Diagnosis Procedure .....	115	<b>DTC P1705 THROTTLE POSITION SENSOR .....</b>	<b>130</b>
<b>DTC P0732 A/T 2ND GEAR FUNCTION .....</b>	<b>116</b>	Description .....	130
Description .....	116	CONSULT-III Reference Value in Data Monitor	
On Board Diagnosis Logic .....	116	Mode .....	130
Possible Cause .....	116	On Board Diagnosis Logic .....	130
DTC Confirmation Procedure .....	116	Possible Cause .....	130
Diagnosis Procedure .....	117	DTC Confirmation Procedure .....	130
		Diagnosis Procedure .....	130

<b>DTC P1710 A/T FLUID TEMPERATURE SENSOR CIRCUIT</b> .....	132	Description .....	147	
Description .....	132	CONSULT-III Reference Value in Data Monitor		A
CONSULT-III Reference Value in Data Monitor		Mode .....	147	
Mode .....	132	On Board Diagnosis Logic .....	147	B
On Board Diagnosis Logic .....	132	Possible Cause .....	147	
Possible Cause .....	132	DTC Confirmation Procedure .....	147	
DTC Confirmation Procedure .....	132	Diagnosis Procedure .....	147	
Wiring Diagram - AT - FTS .....	133			
Diagnosis Procedure .....	133	<b>DTC P1767 HIGH AND LOW REVERSE CLUTCH SOLENOID VALVE</b> .....	149	AT
Component Inspection .....	135	Description .....	149	
<b>DTC P1721 VEHICLE SPEED SENSOR MTR.</b> .....	137	CONSULT-III Reference Value in Data Monitor		D
Description .....	137	Mode .....	149	
CONSULT-III Reference Value in Data Monitor		On Board Diagnosis Logic .....	149	
Mode .....	137	Possible Cause .....	149	E
On Board Diagnosis Logic .....	137	DTC Confirmation Procedure .....	149	
Possible Cause .....	137	Diagnosis Procedure .....	149	
DTC Confirmation Procedure .....	137	<b>DTC P1772 LOW COAST BRAKE SOLENOID VALVE</b> .....	151	F
Diagnosis Procedure .....	137	Description .....	151	
<b>DTC P1730 A/T INTERLOCK</b> .....	139	CONSULT-III Reference Value in Data Monitor		G
Description .....	139	Mode .....	151	
On Board Diagnosis Logic .....	139	On Board Diagnosis Logic .....	151	
Possible Cause .....	139	Possible Cause .....	151	H
DTC Confirmation Procedure .....	139	DTC Confirmation Procedure .....	151	
Judgement of A/T Interlock .....	139	Diagnosis Procedure .....	151	
Diagnosis Procedure .....	139	<b>DTC P1774 LOW COAST BRAKE SOLENOID VALVE FUNCTION</b> .....	153	I
<b>DTC P1731 A/T 1ST ENGINE BRAKING</b> .....	141	Description .....	153	
Description .....	141	CONSULT-III Reference Value in Data Monitor		J
CONSULT-III Reference Value in Data Monitor		Mode .....	153	
Mode .....	141	On Board Diagnosis Logic .....	153	
On Board Diagnosis Logic .....	141	Possible Cause .....	153	K
Possible Cause .....	141	DTC Confirmation Procedure .....	153	
DTC Confirmation Procedure .....	141	Diagnosis Procedure .....	153	
Diagnosis Procedure .....	141	<b>DTC P1815 MANUAL MODE SWITCH</b> .....	155	L
<b>DTC P1752 INPUT CLUTCH SOLENOID VALVE</b> .....	143	Description .....	155	
Description .....	143	CONSULT-III Reference Value in Data Monitor		M
CONSULT-III Reference Value in Data Monitor		Mode .....	155	
Mode .....	143	On Board Diagnosis Logic .....	155	
On Board Diagnosis Logic .....	143	Possible Cause .....	155	N
Possible Cause .....	143	DTC Confirmation Procedure .....	155	
DTC Confirmation Procedure .....	143	Wiring Diagram - AT - MMSW .....	156	
Diagnosis Procedure .....	143	Diagnosis Procedure .....	158	
<b>DTC P1757 FRONT BRAKE SOLENOID VALVE</b> .....	145	Component Inspection .....	159	O
Description .....	145	<b>MAIN POWER SUPPLY AND GROUND CIRCUIT</b> .....	160	P
CONSULT-III Reference Value in Data Monitor		Wiring Diagram - AT - MAIN .....	160	
Mode .....	145	Diagnosis Procedure .....	161	
On Board Diagnosis Logic .....	145	<b>CLOSED THROTTLE POSITION AND WIDE OPEN THROTTLE POSITION CIRCUIT</b> .....	164	
Possible Cause .....	145	CONSULT-III Reference Value in Data Monitor		
DTC Confirmation Procedure .....	145	Mode .....	164	
Diagnosis Procedure .....	145	Diagnosis Procedure .....	164	
<b>DTC P1762 DIRECT CLUTCH SOLENOID VALVE</b> .....	147			

<b>BRAKE SIGNAL CIRCUIT</b> .....	<b>165</b>	<b>ON-VEHICLE SERVICE</b> .....	<b>215</b>
CONSULT-III Reference Value in Data Monitor		Control Valve with TCM and A/T Fluid Temperature Sensor 2 .....	215
Mode .....	165	Parking Component (2WD Models Only) .....	226
Diagnosis Procedure .....	165	Rear Oil Seal .....	233
<b>A/T INDICATOR CIRCUIT</b> .....	<b>166</b>	Revolution Sensor Component (2WD Models Only) .....	233
Description .....	166	<b>AIR BREATHING HOSE</b> .....	<b>239</b>
CONSULT-III Reference Value in Data Monitor		Removal and Installation .....	239
Mode .....	166	<b>TRANSMISSION ASSEMBLY</b> .....	<b>241</b>
Diagnosis Procedure .....	166	Removal and Installation (2WD Models) .....	241
<b>TROUBLE DIAGNOSIS FOR SYMPTOMS</b> ....	<b>167</b>	Removal and Installation (AWD Models) .....	243
Wiring Diagram - AT - NONDTC .....	167	<b>OVERHAUL</b> .....	<b>249</b>
A/T Check Indicator Lamp Does Not Come On ....	170	Component .....	249
Engine Cannot Be Started in "P" or "N" Position ..	170	Oil Channel .....	261
In "P" Position, Vehicle Moves When Pushed .....	171	Location of Adjusting Shims, Needle Bearings, Thrust Washers and Snap Rings .....	264
In "N" Position, Vehicle Moves .....	172	<b>DISASSEMBLY</b> .....	<b>267</b>
Large Shock ("N" to "D" Position) .....	173	Disassembly .....	267
Vehicle Does Not Creep Backward in "R" Position ..	175	<b>REPAIR FOR COMPONENT PARTS</b> .....	<b>285</b>
Vehicle Does Not Creep Forward in "D" Position ..	178	Oil Pump .....	285
Vehicle Cannot Be Started from D1 .....	180	Front Sun Gear, 3rd One-Way Clutch .....	287
A/T Does Not Shift: D1→ D2 .....	182	Front Carrier, Input Clutch, Rear Internal Gear ....	289
A/T Does Not Shift: D2→ D3 .....	184	Mid Sun Gear, Rear Sun Gear, High and Low Reverse Clutch Hub .....	295
A/T Does Not Shift: D3→ D4 .....	186	High and Low Reverse Clutch .....	301
A/T Does Not Shift: D4→ D5 .....	188	Direct Clutch .....	303
A/T Does Not Lock-up .....	190	<b>ASSEMBLY</b> .....	<b>306</b>
A/T Does Not Hold Lock-up Condition .....	192	Assembly (1) .....	306
Lock-up Is Not Released .....	194	Adjustment .....	320
Engine Speed Does Not Return to Idle .....	194	Assembly (2) .....	323
Cannot Be Changed to Manual Mode .....	195	<b>SERVICE DATA AND SPECIFICATIONS (SDS)</b> .....	<b>330</b>
A/T Does Not Shift: 5th Gear → 4th Gear .....	196	General Specification .....	330
A/T Does Not Shift: 4th Gear → 3rd Gear .....	197	Vehicle Speed at Which Gear Shifting Occurs ....	330
A/T Does Not Shift: 3rd Gear → 2nd Gear .....	199	Vehicle Speed at Which Lock-up Occurs/Releases .....	331
A/T Does Not Shift: 2nd Gear → 1st Gear .....	201	Stall Speed .....	331
Vehicle Does Not Decelerate by Engine Brake ....	202	Line Pressure .....	331
<b>SHIFT CONTROL SYSTEM</b> .....	<b>205</b>	A/T Fluid Temperature Sensor .....	332
Control Device Removal and Installation .....	205	Turbine Revolution Sensor .....	332
Control Rod Removal and Installation .....	206	Vehicle Speed Sensor A/T (Revolution Sensor) ..	332
Adjustment of A/T Position .....	207	Reverse Brake .....	332
Checking of A/T Position .....	207	Total End Play .....	332
<b>A/T SHIFT LOCK SYSTEM</b> .....	<b>208</b>		
Description .....	208		
Shift Lock System Electrical Parts Location .....	208		
Wiring Diagram - AT - SHIFT .....	209		
Diagnosis Procedure .....	209		
<b>KEY INTERLOCK CABLE</b> .....	<b>212</b>		
Component .....	212		
Removal and Installation .....	212		

# INDEX FOR DTC

< SERVICE INFORMATION >

## SERVICE INFORMATION

### INDEX FOR DTC

#### Alphabetical Index

INFOID:000000001327120

**NOTE:**

If “DTC U1000” is displayed with other DTCs, first perform the trouble diagnosis for “DTC U1000 CAN COMMUNICATION”. Refer to [AT-94](#).

Items (CONSULT-III screen terms)	DTC		Reference page
	OBD-II	Except OBD-II	
	CONSULT-III GST <sup>(*)</sup>	CONSULT-III only “TRANS- MISSION”	
A/T 1ST E/BRAKING	—	P1731	<a href="#">AT-141</a>
ATF 1ST GR FNCTN	P0731	P0731	<a href="#">AT-114</a>
ATF 2ND GR FNCTN	P0732	P0732	<a href="#">AT-116</a>
ATF 3RD GR FNCTN	P0733	P0733	<a href="#">AT-118</a>
ATF 4TH GR FNCTN	P0734	P0734	<a href="#">AT-120</a>
ATF 5TH GR FNCTN	P0735	P0735	<a href="#">AT-122</a>
A/T INTERLOCK	P1730	P1730	<a href="#">AT-139</a>
A/T TCC S/V FNCTN	P0744 <sup>(*)2</sup>	P0744	<a href="#">AT-126</a>
ATF TEMP SEN/CIRC	P0710	P1710	<a href="#">AT-132</a>
CAN COMM CIRCUIT	U1000	U1000	<a href="#">AT-94</a>
D/C SOLENOID/CIRC	P1762	P1762	<a href="#">AT-147</a>
ENGINE SPEED SIG	P0725	P0725	<a href="#">AT-112</a>
FR/B SOLENOID/CIRC	P1757	P1757	<a href="#">AT-145</a>
HLR/C SOL/CIRC	P1767	P1767	<a href="#">AT-149</a>
I/C SOLENOID/CIRC	P1752	P1752	<a href="#">AT-143</a>
L/PRESS SOL/CIRC	P0745	P0745	<a href="#">AT-128</a>
LC/B SOLENOID/CIRC	P1772	P1772	<a href="#">AT-151</a>
LC/B SOLENOID FNCT	P1774 <sup>(*)2</sup>	P1774	<a href="#">AT-153</a>
MANU MODE SW/CIRC	—	P1815	<a href="#">AT-155</a>
PNP SW/CIRC	P0705	P0705	<a href="#">AT-102</a>
STARTER RELAY/CIRC	—	P0615	<a href="#">AT-97</a>
TCC SOLENOID/CIRC	P0740	P0740	<a href="#">AT-124</a>
TCM	P0700	P0700	<a href="#">AT-101</a>
TP SEN/CIRC A/T	P1705	P1705	<a href="#">AT-130</a>
TURBINE REV S/CIRC	P0717	P0717	<a href="#">AT-106</a>
VEH SPD SE/CIR-MTR	—	P1721	<a href="#">AT-137</a>
VEH SPD SEN/CIR AT	P0720	P0720	<a href="#">AT-108</a>

\*1: These numbers are prescribed by SAE J2012.

\*2: These malfunctions cannot be displayed MIL if another malfunction is assigned to MIL.

#### DTC No. Index

INFOID:000000001327121

**NOTE:**

If “DTC U1000” is displayed with other DTCs, first perform the trouble diagnosis for “DTC U1000 CAN COMMUNICATION”. Refer to [AT-94](#).

# INDEX FOR DTC

## < SERVICE INFORMATION >

DTC		Items (CONSULT-III screen terms)	Reference page
OBD-II	Except OBD-II		
CONSULT-III GST <sup>(*1)</sup>	CONSULT-III only "TRANSMIS- SION"		
—	P0615	STARTER RELAY/CIRC	<a href="#">AT-97</a>
P0700	P0700	TCM	<a href="#">AT-101</a>
P0705	P0705	PNP SW/CIRC	<a href="#">AT-102</a>
P0710	P1710	ATF TEMP SEN/CIRC	<a href="#">AT-132</a>
P0717	P0717	TURBINE REV S/CIRC	<a href="#">AT-106</a>
P0720	P0720	VEH SPD SEN/CIR AT	<a href="#">AT-108</a>
P0725	P0725	ENGINE SPEED SIG	<a href="#">AT-112</a>
P0731	P0731	A/T 1ST GR FNCTN	<a href="#">AT-114</a>
P0732	P0732	A/T 2ND GR FNCTN	<a href="#">AT-116</a>
P0733	P0733	A/T 3RD GR FNCTN	<a href="#">AT-118</a>
P0734	P0734	A/T 4TH GR FNCTN	<a href="#">AT-120</a>
P0735	P0735	A/T 5TH GR FNCTN	<a href="#">AT-122</a>
P0740	P0740	TCC SOLENOID/CIRC	<a href="#">AT-124</a>
P0744 <sup>(*2)</sup>	P0744	A/T TCC S/V FNCTN	<a href="#">AT-126</a>
P0745	P0745	L/PRESS SOL/CIRC	<a href="#">AT-128</a>
P1705	P1705	TP SEN/CIRC A/T	<a href="#">AT-130</a>
—	P1721	VEH SPD SE/CIR-MTR	<a href="#">AT-137</a>
P1730	P1730	A/T INTERLOCK	<a href="#">AT-139</a>
—	P1731	A/T 1ST E/BRAKING	<a href="#">AT-141</a>
P1752	P1752	I/C SOLENOID/CIRC	<a href="#">AT-143</a>
P1757	P1757	FR/B SOLENOID/CIRC	<a href="#">AT-145</a>
P1762	P1762	D/C SOLENOID/CIRC	<a href="#">AT-147</a>
P1767	P1767	HLR/C SOL/CIRC	<a href="#">AT-149</a>
P1772	P1772	LC/B SOLENOID/CIRC	<a href="#">AT-151</a>
P1774 <sup>(*2)</sup>	P1774	LC/B SOLENOID FNCT	<a href="#">AT-153</a>
—	P1815	MANU MODE SW/CIRC	<a href="#">AT-155</a>
U1000	U1000	CAN COMM CIRCUIT	<a href="#">AT-94</a>

\*1: These numbers are prescribed by SAE J2012.

\*2: These malfunctions cannot be displayed MIL if another malfunction is assigned to MIL.

# PRECAUTIONS

< SERVICE INFORMATION >

## PRECAUTIONS

### Precaution for Supplemental Restraint System (SRS) "AIR BAG" and "SEAT BELT PRE-TENSIONER"

INFOID:000000001612925

The Supplemental Restraint System such as "AIR BAG" and "SEAT BELT PRE-TENSIONER", used along with a front seat belt, helps to reduce the risk or severity of injury to the driver and front passenger for certain types of collision. This system includes seat belt switch inputs and dual stage front air bag modules. The SRS system uses the seat belt switches to determine the front air bag deployment, and may only deploy one front air bag, depending on the severity of a collision and whether the front occupants are belted or unbelted. Information necessary to service the system safely is included in the "SUPPLEMENTAL RESTRAINT SYSTEM" and "SEAT BELTS" of this Service Manual.

#### **WARNING:**

- To avoid rendering the SRS inoperative, which could increase the risk of personal injury or death in the event of a collision which would result in air bag inflation, all maintenance must be performed by an authorized NISSAN/INFINITI dealer.
- Improper maintenance, including incorrect removal and installation of the SRS, can lead to personal injury caused by unintentional activation of the system. For removal of Spiral Cable and Air Bag Module, see the "SUPPLEMENTAL RESTRAINT SYSTEM".
- Do not use electrical test equipment on any circuit related to the SRS unless instructed to in this Service Manual. SRS wiring harnesses can be identified by yellow and/or orange harnesses or harness connectors.

### Precaution for On Board Diagnosis (OBD) System of A/T and Engine

INFOID:000000001327123

The ECM has an on board diagnostic system. It will light up the malfunction indicator lamp (MIL) to warn the driver of a malfunction causing emission deterioration.

#### **CAUTION:**

- Be sure to turn the ignition switch OFF and disconnect the battery cable from the negative terminal before any repair or inspection work. The open/short circuit of related switches, sensors, solenoid valves, etc. Will cause the MIL to light up.
- Be sure to connect and lock the connectors securely after work. A loose (unlocked) connector will cause the MIL to light up due to an open circuit. (Be sure the connector is free from water, grease, dirt, bent terminals, etc.)
- Be sure to route and secure the harnesses properly after work. Interference of the harness with a bracket, etc. May cause the MIL to light up due to a short circuit.
- Be sure to connect rubber tubes properly after work. A misconnected or disconnected rubber tube may cause the MIL to light up due to a malfunction of the EVAP system or fuel injection system, etc.
- Be sure to erase the unnecessary malfunction information (repairs completed) from the TCM and ECM before returning the vehicle to the customer.

### Precaution

INFOID:000000001327124

- Before connecting or disconnecting the A/T assembly harness connector, turn ignition switch OFF and disconnect the battery cable from the negative terminal. Because battery voltage is applied to TCM even if ignition switch is turned OFF.

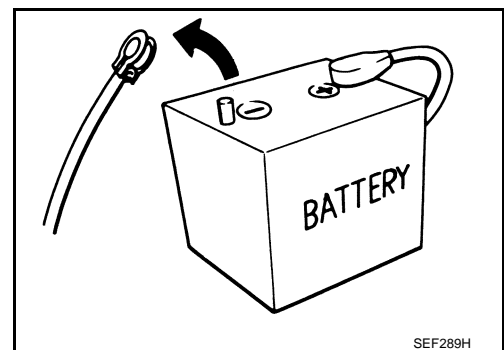

# PRECAUTIONS

## < SERVICE INFORMATION >

- After performing each TROUBLE DIAGNOSIS, perform “DTC (Diagnostic Trouble Code) Confirmation Procedure”. If the repair is completed the DTC should not be displayed in the “DTC Confirmation Procedure”.

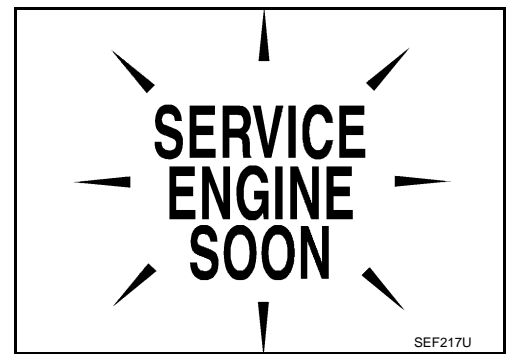

- Always use the specified brand of ATF. Refer to [MA-9, "Fluids and Lubricants"](#).
- Use lint-free paper not cloth rags during work.
- After replacing the ATF, dispose of the waste oil using the methods prescribed by law, ordinance, etc.
- Before proceeding with disassembly, thoroughly clean the outside of the transmission. It is important to prevent the internal parts from becoming contaminated by dirt or other foreign matter.
- Disassembly should be done in a clean work area.
- Use lint-free paper or towels for wiping parts clean. Common shop rags can leave fibers that could interfere with the operation of the transmission.
- Place disassembled parts in order for easier and proper assembly.
- All parts should be carefully cleansed with a general purpose, non-flammable solvent before inspection or reassembly.
- Gaskets, seals and O-rings should be replaced any time the transmission is disassembled.
- It is very important to perform functional tests whenever they are indicated.
- The valve body contains precision parts and requires extreme care when parts are removed and serviced. Place disassembled valve body parts in order for easier and proper assembly. Care will also prevent springs and small parts from becoming scattered or lost.
- Properly installed valves, sleeves, plugs, etc. will slide along bores in valve body under their own weight.
- Before assembly, apply a coat of recommended ATF to all parts. Apply petroleum jelly to protect O-rings and seals, or hold bearings and washers in place during assembly. Do not use grease.
- Extreme care should be taken to avoid damage to O-rings, seals and gaskets when assembling.
- After overhaul, refill the transmission with new ATF.
- When the A/T drain plug is removed, only some of the ATF is drained. Old ATF will remain in torque converter and ATF cooling system.  
Always follow the procedures under “Changing A/T Fluid” in the AT section when changing A/T fluid. Refer to [AT-11, "Changing A/T Fluid"](#), [AT-11, "Checking A/T Fluid"](#).

## Service Notice or Precaution

INFOID:000000001327125

### ATF COOLER SERVICE

If ATF contains frictional material (clutches, bands, etc.), or if an A/T is repaired, overhauled, or replaced, inspect and clean the A/T fluid cooler mounted in the radiator or replace the radiator. Flush cooler lines using cleaning solvent and compressed air after repair. For A/T fluid cooler cleaning procedure, refer to [AT-13, "A/T Fluid Cooler Cleaning"](#). For radiator replacement, refer to [CO-13](#) (for VQ35DE), [CO-40](#) (for VK45DE).

### OBD-II SELF-DIAGNOSIS

- A/T self-diagnosis is performed by the TCM in combination with the ECM. The results can be read through the blinking pattern of the A/T CHECK indicator or the malfunction indicator lamp (MIL). Refer to the table on [AT-84, "CONSULT-III Function \(TRANSMISSION\)"](#) for the indicator used to display each self-diagnostic result.
- The self-diagnostic results indicated by the MIL are automatically stored in both the ECM and TCM memories.

**Always perform the procedure on [AT-38, "OBD-II Diagnostic Trouble Code \(DTC\)"](#) to complete the repair and avoid unnecessary blinking of the MIL.**

For details of OBD-II, refer to [EC-54](#) (for VQ35DE) or [EC-632](#) (for VK45DE).

- **Certain systems and components, especially those related to OBD, may use the new style slide-locking type harness connector. For description and how to disconnect, refer to [PG-68](#).**



# PREPARATION

< SERVICE INFORMATION >

## PREPARATION

### Special Service Tool

INFOID:000000001327126

The actual shapes of Kent-Moore tools may differ from those of special service tools illustrated here.

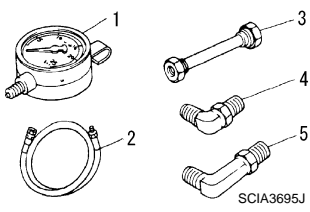
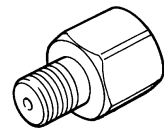
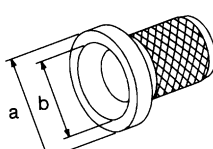
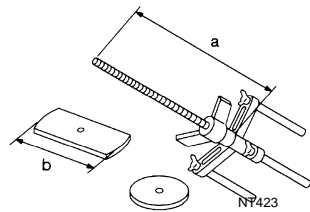
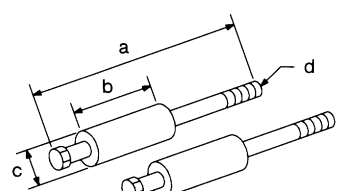
Tool number (Kent-Moore No.) Tool name	Description
<p>ST2505S001 (J-34301-C) Oil pressure gauge set 1. ST25051001 ( — ) Oil pressure gauge 2. ST25052000 ( — ) Hose 3. ST25053000 ( — ) Joint pipe 4. ST25054000 ( — ) Adapter 5. ST25055000 ( — ) Adapter</p> 	<p>Measuring line pressure</p>
<p>KV31103600 (J-45674) Joint pipe adapter (With ST25054000)</p> 	<p>Measuring line pressure</p>
<p>ST33400001 (J-26082) Drift a: 60 mm (2.36 in) dia. b: 47 mm (1.85 in) dia.</p> 	<ul style="list-style-type: none"> <li>• Installing rear oil seal (2WD models)</li> <li>• Installing oil pump housing oil seal</li> </ul>
<p>KV31102400 (J-34285 and J-34285-87) Clutch spring compressor a: 320 mm (12.60 in) b: 174 mm (6.85 in)</p> 	<p>Installing reverse brake return spring retainer</p>
<p>ST25850000 (J-25721-A) Sliding hammer a: 179 mm (7.05 in) b: 70 mm (2.76 in) c: 40 mm (1.57 in) dia. d: M12X1.75P</p> 	<p>Removing oil pump assembly</p>

### Commercial Service Tool

INFOID:000000001327127

# PREPARATION

## < SERVICE INFORMATION >

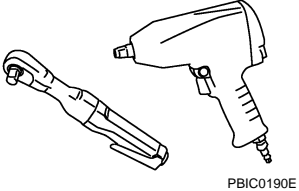
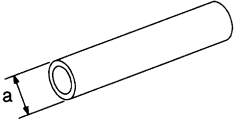
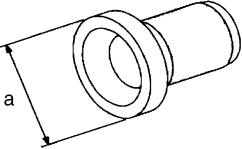
Tool name	Description
<p data-bbox="164 199 272 226">Power tool</p>  <p data-bbox="849 415 922 436">PBIC0190E</p>	<p data-bbox="1010 199 1263 226">Loosening bolts and nuts</p>
<p data-bbox="164 445 391 506">Drift a: 22 mm (0.87 in) dia.</p>  <p data-bbox="849 661 894 682">NT083</p>	<p data-bbox="1010 445 1328 472">Installing manual shaft oil seals</p>
<p data-bbox="164 697 391 758">Drift a: 64 mm (2.52 in) dia.</p>  <p data-bbox="849 913 922 934">SCIA5338E</p>	<p data-bbox="1010 697 1377 724">Installing rear oil seal (AWD models)</p>

# A/T FLUID

< SERVICE INFORMATION >

## A/T FLUID

### Changing A/T Fluid

INFOID:000000001327128

1. Warm up ATF.
2. Stop engine.
3. Loosen the level gauge bolt.
4. Drain ATF from drain plug and refill with new ATF. Always refill same volume with drained ATF.
  - To replace the ATF, pour in new ATF at the A/T fluid charging pipe with the engine idling, at the same time drain the old ATF from the radiator cooler hose return side.
  - When the color of the ATF coming out is almost same as the color of the new ATF, the replacement is complete. The amount of new ATF to use should be 30 to 50% increase of the stipulated amount.

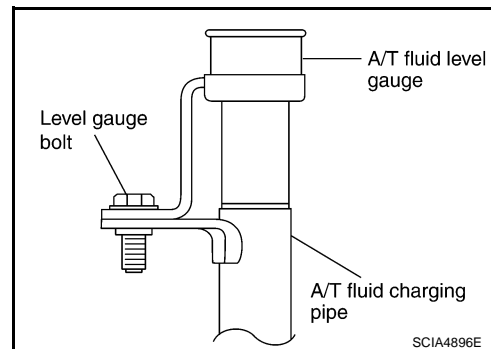

**ATF: Genuine NISSAN Matic J ATF**

**Fluid capacity: 10.3 ℓ (10-7/8 US qt, 9-1/8 Imp qt)**

#### CAUTION:

- Use only Genuine NISSAN Matic J ATF. Do not mix with other ATF.
- Using ATF other than Genuine NISSAN Matic J ATF will cause deterioration in driveability and A/T durability, and may damage the A/T, which is not covered by the warranty.
- When filling ATF, take care not to scatter heat generating parts such as exhaust.
- Do not reuse drain plug gasket.

#### Drain plug:

 : 34 N·m (3.5 kg·m, 25 ft·lb)

5. Run engine at idle speed for 5 minutes.
6. Check A/T fluid level and condition. Refer to [AT-11, "Checking A/T Fluid"](#). If ATF is still dirty, repeat step 2. through 5.
7. Install the removed A/T fluid level gauge into A/T fluid charging pipe.
8. Tighten the level gauge bolt.

#### Level gauge bolt:

 : 5.1 N·m (0.52 kg·m, 45 in·lb)

### Checking A/T Fluid

INFOID:000000001327129

1. Warm up engine.
2. Check for A/T fluid leakage.
3. Loosen the level gauge bolt.
4. Before driving, A/T fluid level can be checked at A/T fluid temperatures of 30 to 50°C (86 to 122°F) using "COLD" range on A/T fluid level gauge as follows.
  - a. Park vehicle on level surface and set parking brake.
  - b. Start engine and move selector lever through each gear position. Leave selector lever in "P" position.
  - c. Check A/T fluid level with engine idling.
  - d. Remove A/T fluid level gauge and wipe clean with lint-free paper.

#### CAUTION:

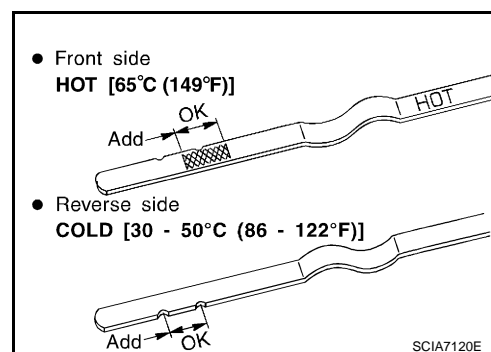

# A/T FLUID

## < SERVICE INFORMATION >

**When wiping away the A/T fluid level gauge, always use lint-free paper, not a cloth one.**

- e. Re-insert A/T fluid level gauge into A/T fluid charging pipe as far as it will go.

**CAUTION:**

**To check A/T fluid level, insert the A/T fluid level gauge until the cap contacts the end of the A/T fluid charging pipe, with the A/T fluid level gauge reversed from the normal attachment conditions.**

- f. Remove A/T fluid level gauge and note reading. If reading is at low side of range, add ATF to the A/T fluid charging pipe.

**CAUTION:**

**Do not overfill.**

5. Drive vehicle for approximately 5 minutes in urban areas.
6. Make the A/T fluid temperature approximately 65°C (149°F).

**NOTE:**

**A/T fluid level will be greatly affected by temperature as shown in figure. Therefore, be certain to perform operation while checking data with CONSULT-III.**

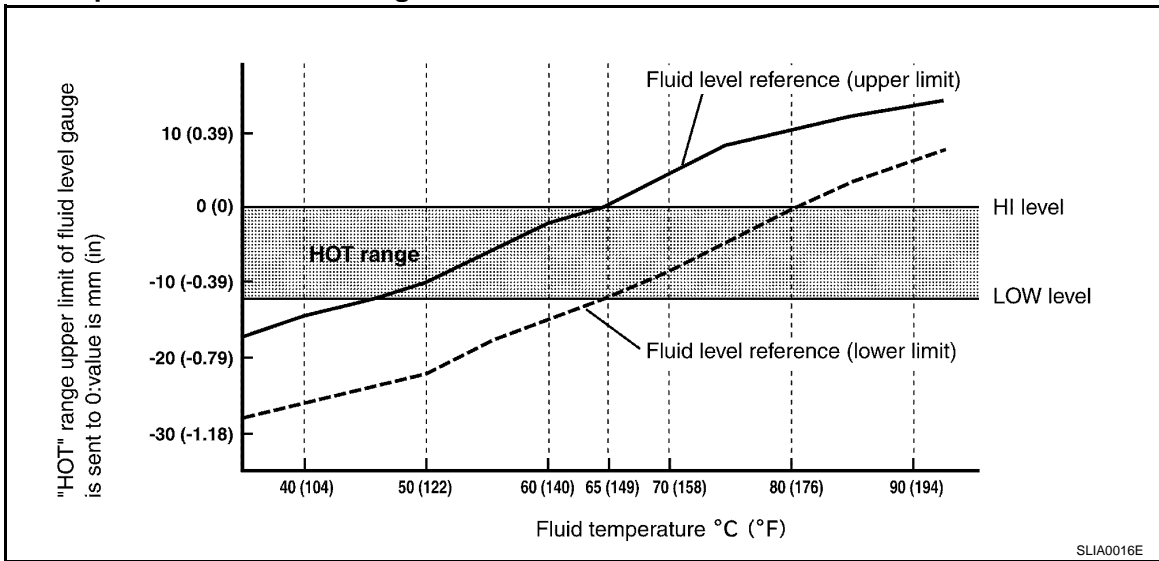

- a. Connect CONSULT-III to data link connector.
- b. Select "MAIN SIGNALS" in "DATA MONITOR" mode for "TRANSMISSION" with CONSULT-III.
- c. Read out the value of "ATF TEMP 1".
7. Recheck A/T fluid level at A/T fluid temperatures of approximately 65°C (149°F) using "HOT" range on A/T fluid level gauge.

**CAUTION:**

- **When wiping away the A/T fluid level gauge, always use lint-free paper, not a cloth one.**
- **To check A/T fluid level, insert the A/T fluid level gauge until the cap contacts the end of the A/T fluid charging pipe, with the A/T fluid level gauge reversed from the normal attachment conditions as shown.**

8. Check A/T fluid condition.
  - If ATF is very dark or smells burned, check operation of A/T. Flush cooling system after repair of A/T.
  - If ATF contains frictional material (clutches, bands, etc.), replace radiator and flush cooler line using cleaning solvent and compressed air after repair of A/T. Refer to [CO-13](#) (for VQ35DE) or [CO-40](#) (for VK45DE) and [AT-13, "A/T Fluid Cooler Cleaning"](#).

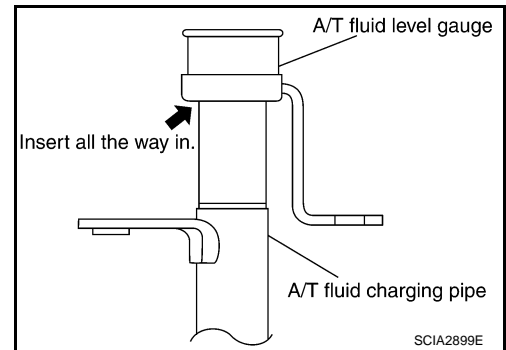

# A/T FLUID

## < SERVICE INFORMATION >

9. Install the removed A/T fluid level gauge in the A/T fluid charging pipe.
10. Tighten level gauge bolt.

### Level gauge bolt:

 : 5.1 N·m (0.52 kg·m, 45 in·lb)

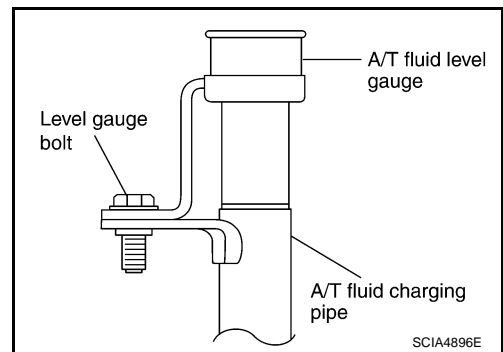

## A/T Fluid Cooler Cleaning

INFOID:000000001327130

Whenever an A/T is replaced, the A/T fluid cooler mounted in the radiator must be inspected and cleaned. Metal debris and friction material, if present, can become trapped in the A/T fluid cooler. This debris can contaminate the newly serviced A/T or, in severe cases, can block or restrict the flow of ATF. In either case, malfunction of the newly serviced A/T may result.

Debris, if present, may build up as ATF enters the cooler inlet. It will be necessary to back flush the cooler through the cooler outlet in order to flush out any built up debris.

### A/T FLUID COOLER CLEANING PROCEDURE

1. Position an oil pan under the A/T's inlet and outlet cooler hoses.
2. Identify the inlet and outlet A/T fluid cooler hoses.
3. Disconnect the A/T fluid cooler inlet and outlet rubber hoses from the steel cooler tubes or bypass valve.

#### NOTE:

Replace the cooler hoses if rubber material from the hose remains on the tube fitting.

4. Allow any ATF that remains in the cooler hoses to drain into the oil pan.

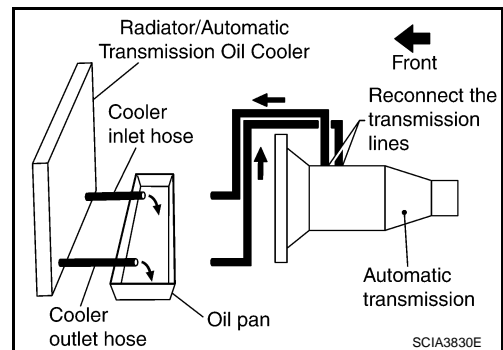

5. Insert the extension adapter hose of a can of Transmission Cooler Cleaner (Nissan P/N 999MP-AM006) into the cooler outlet hose.

#### CAUTION:

- Wear safety glasses and rubber gloves when spraying the Transmission Cooler Cleaner.
- Spray Transmission Cooler Cleaner only with adequate ventilation.
- Avoid contact with eyes and skin.
- Do not breath vapors or spray mist.

6. Hold the hose and can as high as possible and spray Transmission Cooler Cleaner in a continuous stream into the cooler outlet hose until ATF flows out of the cooler inlet hose for 5 seconds.

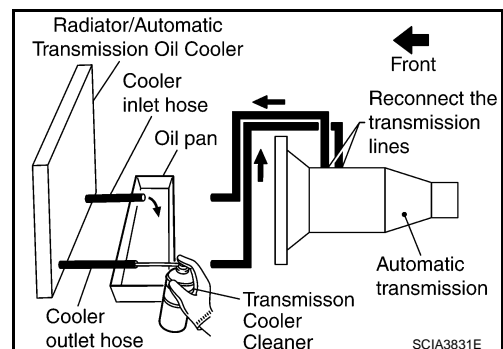

## A/T FLUID

### < SERVICE INFORMATION >

7. Insert the tip of an air gun into the end of the cooler outlet hose.
8. Wrap a shop rag around the air gun tip and of the cooler outlet hose.
9. Blow compressed air regulated to 5 to 9 kg/cm<sup>2</sup> (70 to 130 psi) through the cooler outlet hose for 10 seconds to force out any remaining ATF.
10. Repeat steps 5 through 9 three additional times.
11. Position an oil pan under the banjo bolts that connect the A/T fluid cooler steel lines to the A/T.
12. Remove the banjo bolts.
13. Flush each steel line from the cooler side back toward the A/T by spraying Transmission Cooler Cleaner in a continuous stream for 5 seconds.
14. Blow compressed air regulated to 5 to 9 kg/cm<sup>2</sup> (70 to 130 psi) through each steel line from the cooler side back toward the transmission for 10 seconds to force out any remaining ATF.
15. Ensure all debris is removed from the steel cooler lines.
16. Ensure all debris is removed from the banjo bolts and fittings.
17. Perform "A/T FLUID COOLER DIAGNOSIS PROCEDURE".

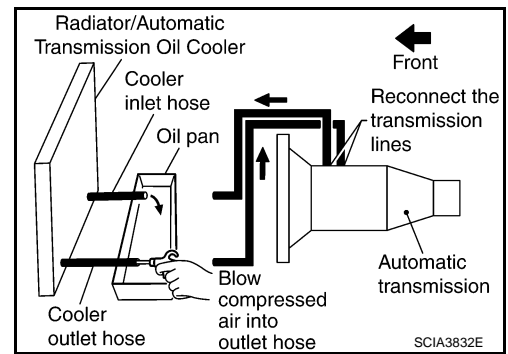

### A/T FLUID COOLER DIAGNOSIS PROCEDURE

#### NOTE:

Insufficient cleaning of the cooler inlet hose exterior may lead to inaccurate debris identification.

1. Position an oil pan under the A/T's inlet and outlet cooler hoses.
2. Clean the exterior and tip of the cooler inlet hose.
3. Insert the extension adapter hose of a can of Transmission Cooler Cleaner (Nissan P/N 999MP-AM006) into the cooler outlet hose.

#### CAUTION:

- Wear safety glasses and rubber gloves when spraying the Transmission Cooler Cleaner.
  - Spray Transmission Cooler Cleaner only with adequate ventilation.
  - Avoid contact with eyes and skin.
  - Do not breath vapors or spray mist.
4. Hold the hose and can as high as possible and spray Transmission Cooler Cleaner in a continuous stream into the cooler outlet hose until ATF flows out of the cooler inlet hose for 5 seconds.
  5. Tie a common white, basket-type coffee filter to the end of the cooler inlet hose.

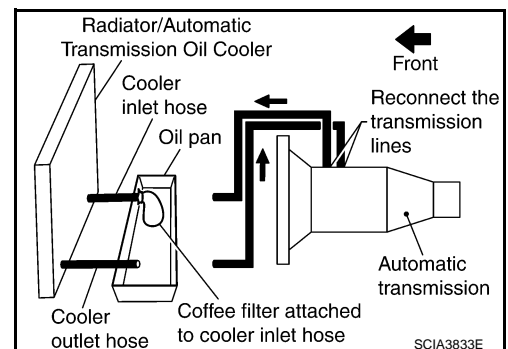
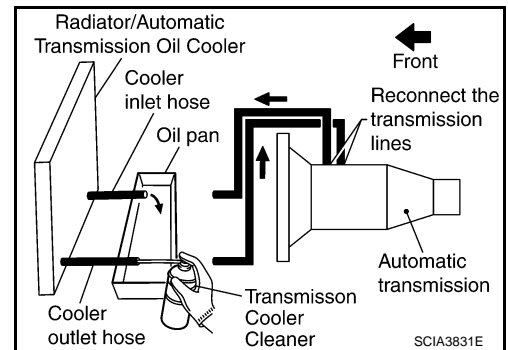

# A/T FLUID

## < SERVICE INFORMATION >

6. Insert the tip of an air gun into the end of the cooler outlet hose.
7. Wrap a shop rag around the air gun tip and end of cooler outlet hose.
8. Blow compressed air regulated to 5 to 9 kg/cm<sup>2</sup> (70 to 130 psi) through the cooler outlet hose to force any remaining ATF into the coffee filter.
9. Remove the coffee filter from the end of the cooler inlet hose.
10. Perform "A/T FLUID COOLER INSPECTION PROCEDURE".

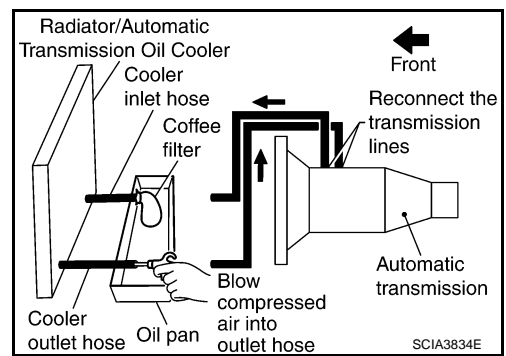

## A/T FLUID COOLER INSPECTION PROCEDURE

1. Inspect the coffee filter for debris.
  - a. If small metal debris less than 1 mm (0.040 in) in size or metal powder is found in the coffee filter, this is normal. If normal debris is found, the A/T fluid cooler/radiator can be re-used and the procedure is ended.
  - b. If one or more pieces of debris are found that are over 1 mm (0.040 in) in size and/or peeled clutch facing material is found in the coffee filter, the fluid cooler is not serviceable. The A/T fluid cooler/radiator must be replaced and the inspection procedure is ended. Refer to [CO-13](#) and [CO-16](#) (for VQ35DE), [CO-40](#) and [CO-44](#) (for VK45DE).

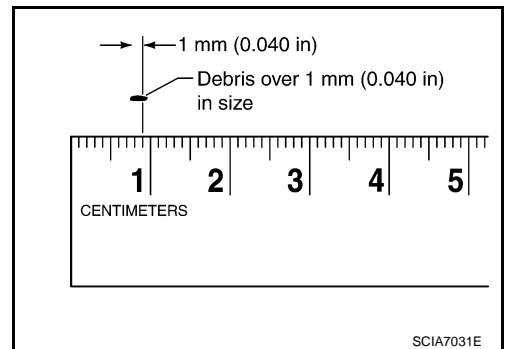
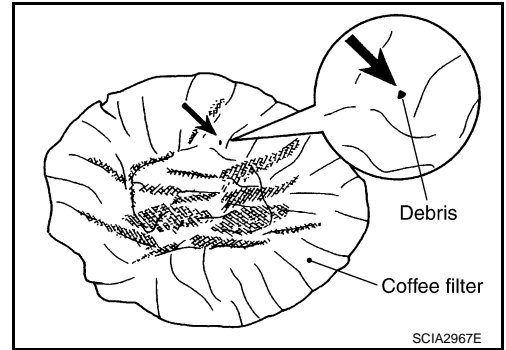

## A/T FLUID COOLER FINAL INSPECTION

After performing all procedures, ensure that all remaining oil is cleaned from all components.

# A/T CONTROL SYSTEM

< SERVICE INFORMATION >

## A/T CONTROL SYSTEM

### Cross-Sectional View (2WD Models)

INFOID:000000001327131

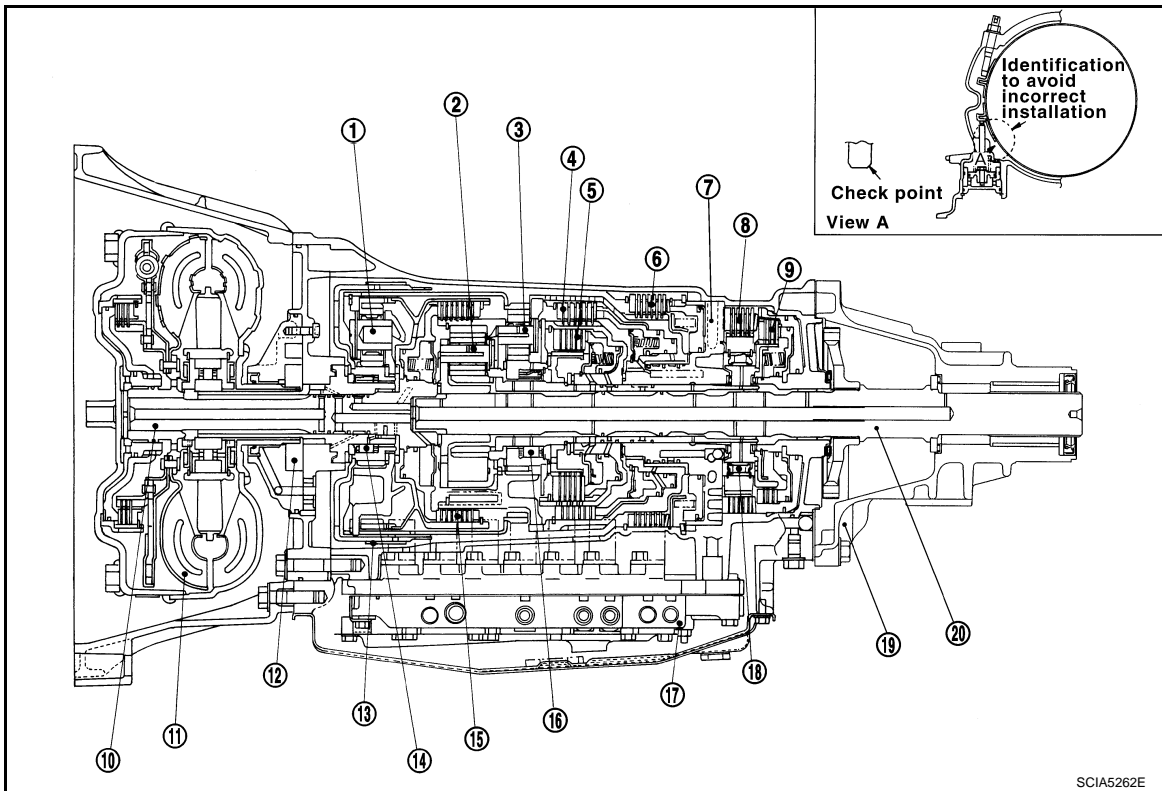

SCIA5262E

- |                         |                                |                            |
|-------------------------|--------------------------------|----------------------------|
| 1. Front planetary gear | 2. Mid planetary gear          | 3. Rear planetary gear     |
| 4. Direct clutch        | 5. High and low reverse clutch | 6. Reverse brake           |
| 7. Drum support         | 8. Forward brake               | 9. Low coast brake         |
| 10. Input shaft         | 11. Torque converter           | 12. Oil pump               |
| 13. Front brake         | 14. 3rd one-way clutch         | 15. Input clutch           |
| 16. 1st one-way clutch  | 17. Control valve with TCM     | 18. Forward one-way clutch |
| 19. Rear extension      | 20. Output shaft               |                            |



# A/T CONTROL SYSTEM

< SERVICE INFORMATION >

## Cross-Sectional View (VQ35DE Models for AWD)

INFOID:000000001327132

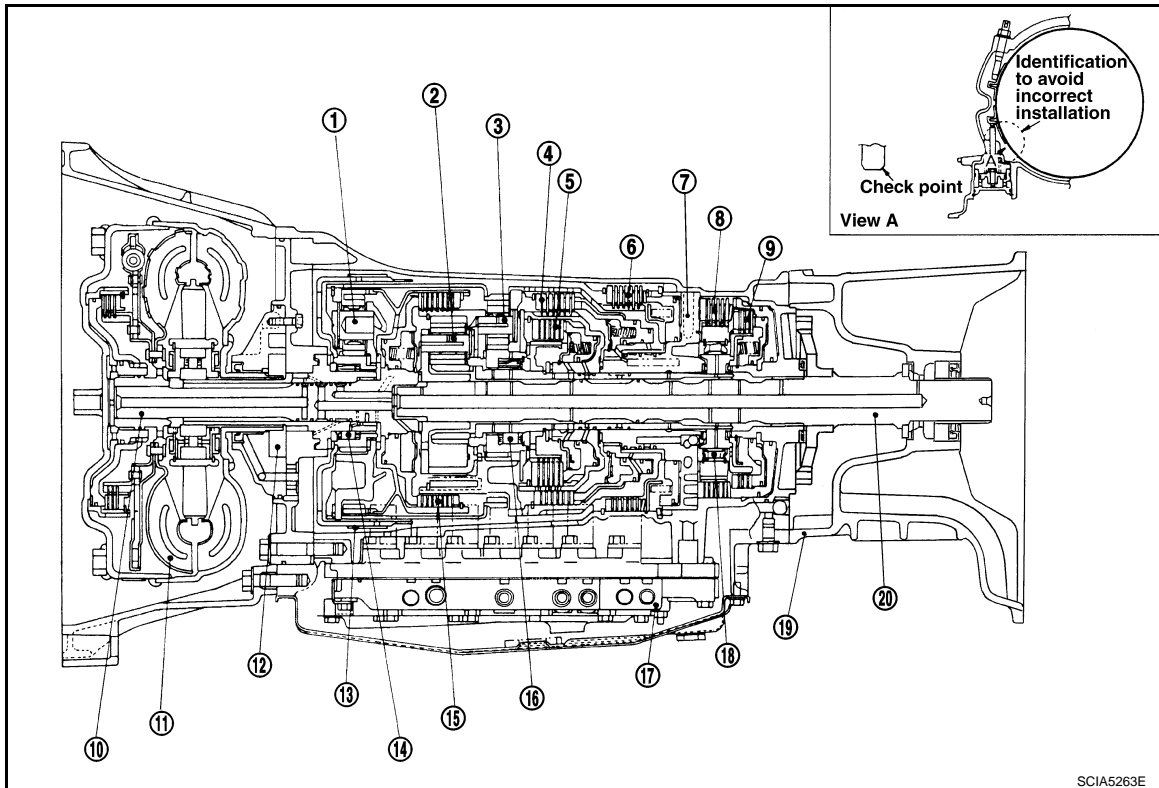

- |                         |                                |                            |
|-------------------------|--------------------------------|----------------------------|
| 1. Front planetary gear | 2. Mid planetary gear          | 3. Rear planetary gear     |
| 4. Direct clutch        | 5. High and low reverse clutch | 6. Reverse brake           |
| 7. Drum support         | 8. Forward brake               | 9. Low coast brake         |
| 10. Input shaft         | 11. Torque converter           | 12. Oil pump               |
| 13. Front brake         | 14. 3rd one-way clutch         | 15. Input clutch           |
| 16. 1st one-way clutch  | 17. Control valve with TCM     | 18. Forward one-way clutch |
| 19. Adapter case        | 20. Output shaft               |                            |

A  
B  
AT  
D  
E  
F  
G  
H  
I  
J  
K  
L  
M  
N  
O  
P

# A/T CONTROL SYSTEM

< SERVICE INFORMATION >

## Cross-Sectional View (VK45DE Models for AWD)

INFOID:000000001327133

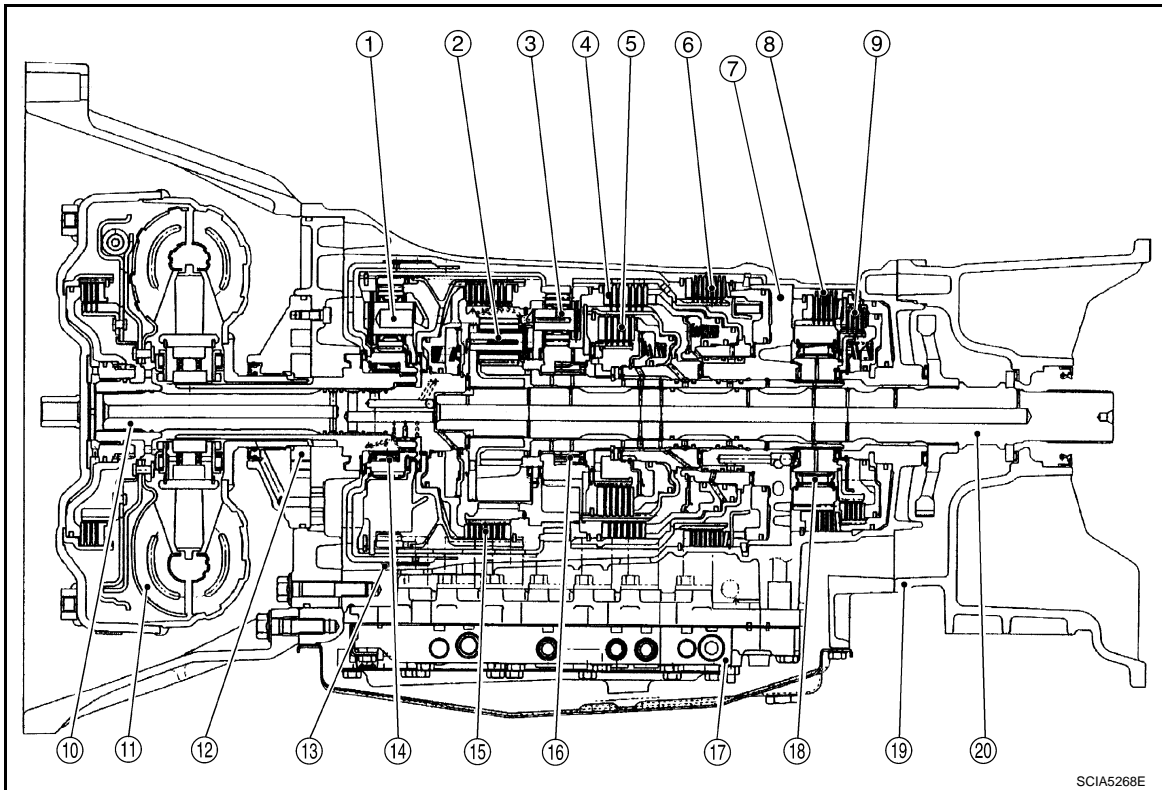

- |                         |                                |                            |
|-------------------------|--------------------------------|----------------------------|
| 1. Front planetary gear | 2. Mid planetary gear          | 3. Rear planetary gear     |
| 4. Direct clutch        | 5. High and low reverse clutch | 6. Reverse brake           |
| 7. Drum support         | 8. Forward brake               | 9. Low coast brake         |
| 10. Input shaft         | 11. Torque converter           | 12. Oil pump               |
| 13. Front brake         | 14. 3rd one-way clutch         | 15. Input clutch           |
| 16. 1st one-way clutch  | 17. Control valve with TCM     | 18. Forward one-way clutch |
| 19. Adapter case        | 20. Output shaft               |                            |

## Shift Mechanism

INFOID:000000001327134

The A/T uses compact triple planetary gear systems to improve power transmission efficiency, simplify construction and reduce weight.

It also employs an optimum shift control and super wide gear ratios. They improve starting performance and acceleration during medium and high-speed operation.

## CONSTRUCTION

# A/T CONTROL SYSTEM

< SERVICE INFORMATION >

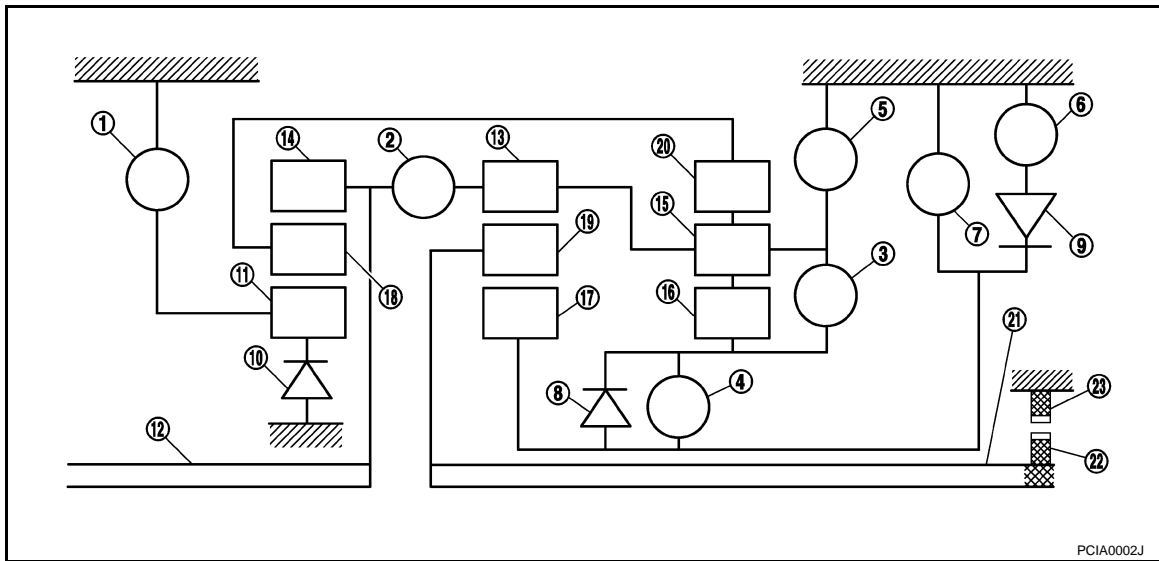

- |                                |                         |                           |
|--------------------------------|-------------------------|---------------------------|
| 1. Front brake                 | 2. Input clutch         | 3. Direct clutch          |
| 4. High and low reverse clutch | 5. Reverse brake        | 6. Forward brake          |
| 7. Low coast brake             | 8. 1st one-way clutch   | 9. Forward one-way clutch |
| 10. 3rd one-way clutch         | 11. Front sun gear      | 12. Input shaft           |
| 13. Mid internal gear          | 14. Front internal gear | 15. Rear carrier          |
| 16. Rear sun gear              | 17. Mid sun gear        | 18. Front carrier         |
| 19. Mid carrier                | 20. Rear internal gear  | 21. Output shaft          |
| 22. Parking gear               | 23. Parking pawl        |                           |

## FUNCTION OF CLUTCH AND BRAKE

Name of the Part	Abbreviation	Function
Front brake (1)	FR/B	Fastens the front sun gear (11).
Input clutch (2)	I/C	Connects the input shaft (12), the front internal gear (14) and the mid internal gear (13).
Direct clutch (3)	D/C	Connects the rear carrier (15) and the rear sun gear (16).
High and low reverse clutch (4)	HLR/C	Connects the mid sun gear (17) and the rear sun gear (16).
Reverse brake (5)	R/B	Fastens the rear carrier (15).
Forward brake (6)	Fwd/B	Fastens the mid sun gear (17).
Low coast brake (7)	LC/B	Fastens the mid sun gear (17).
1st one-way clutch (8)	1st OWC	Allows the rear sun gear (16) to turn freely forward relative to the mid sun gear (17) but fastens it for reverse rotation.
Forward one-way clutch (9)	Fwd OWC	Allows the mid sun gear (17) to turn freely in the forward direction but fastens it for reverse rotation.
3rd one-way clutch (10)	3rd OWC	Allows the front sun gear (11) to turn freely in the forward direction but fastens it for reverse rotation.

# A/T CONTROL SYSTEM

< SERVICE INFORMATION >

## CLUTCH AND BAND CHART

Shift position	I/C	HLR/C	D/C	R/B	FR/B	LC/B	Fwd/B	1st OWC	Fwd OWC	3rd OWC	Remarks
P		△			△						PARK POSITION
R		○		○	○			◎		◎	REVERSE POSITION
N		△			△						NEUTRAL POSITION
D	1st		△ *		△	△ **	○	◎	◎	◎	Automatic shift 1→2→3→4→5
	2nd			○	△		○		◎	◎	
	3rd		○	○		○	△	◇		◎	
	4th	○	○	○			△	◇			
	5th	○	○			○	△	◇		◇	
M5		○	○		○		△	◇		◇	Locks* (held stationary) in 5th gear
M4		○	○	○			△	◇			Locks* (held stationary) in 4th gear
M3			○	○		○	△	◇		◎	Locks* (held stationary) in 3rd gear
M2				○		○	○		◎	◎	Locks* (held stationary) in 2nd gear
M1					○	○	○	◎	◎	◎	Locks* (held stationary) in 1st gear

○ — Operates

◎ — Operates during "progressive" acceleration.

◇ — Operates and affects power transmission while coasting.

△ — Line pressure is applied but does not affect power transmission.

△ \* — Operates under conditions shown in illustration ①.

△ \*\* — Operates under conditions shown in illustration ②. Delay control is applied during D (4,3,2,1) → N shift.

\* : Down shift automatically according to the vehicle speed.

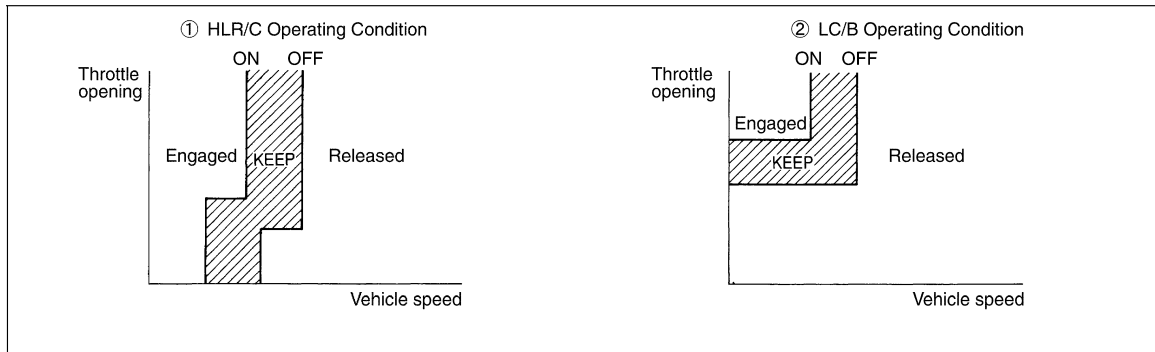

SCIA6962E

## POWER TRANSMISSION

"N" Position

Since both the forward brake and the reverse brake are released, torque from the input shaft drive is not transmitted to the output shaft.

"P" Position

## A/T CONTROL SYSTEM

### < SERVICE INFORMATION >

- The same as for the “N” position, both the forward brake and the reverse brake are released, so torque from the input shaft drive is not transmitted to the output shaft.
- The parking pawl linked with the selector lever meshes with the parking gear and fastens the output shaft mechanically.

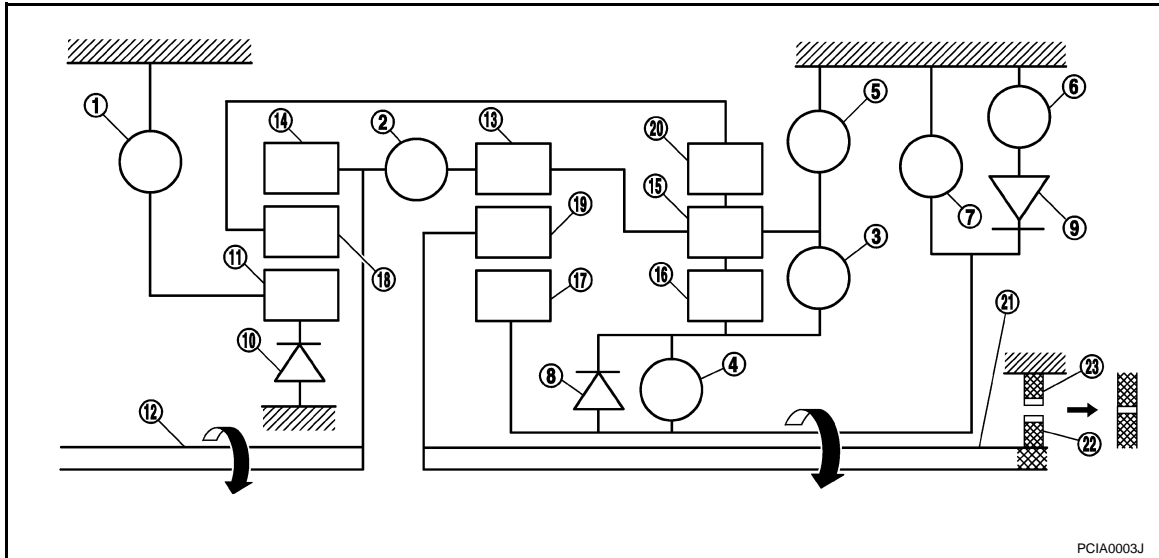

- |                                |                         |                           |
|--------------------------------|-------------------------|---------------------------|
| 1. Front brake                 | 2. Input clutch         | 3. Direct clutch          |
| 4. High and low reverse clutch | 5. Reverse brake        | 6. Forward brake          |
| 7. Low coast brake             | 8. 1st one-way clutch   | 9. Forward one-way clutch |
| 10. 3rd one-way clutch         | 11. Front sun gear      | 12. Input shaft           |
| 13. Mid internal gear          | 14. Front internal gear | 15. Rear carrier          |
| 16. Rear sun gear              | 17. Mid sun gear        | 18. Front carrier         |
| 19. Mid carrier                | 20. Rear internal gear  | 21. Output shaft          |
| 22. Parking gear               | 23. Parking pawl        |                           |

### “D1” Position

- The forward brake and the forward one-way clutch regulate reverse rotation of the mid sun gear.
- The 1st one-way clutch regulates reverse rotation of the rear sun gear.
- The 3rd one-way clutch regulates reverse rotation of the front sun gear.
- During deceleration, the mid sun gear turns forward, so the forward one-way clutch idles and the engine brake is not activated.

# A/T CONTROL SYSTEM

< SERVICE INFORMATION >

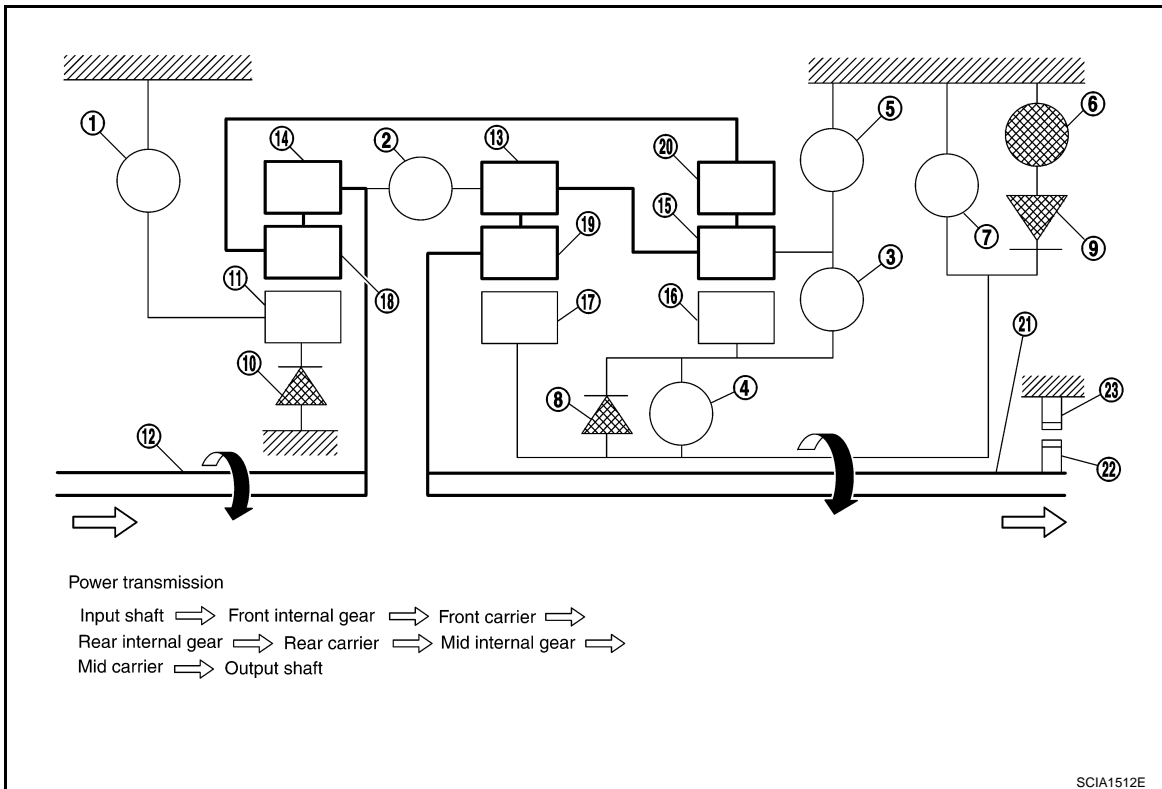

- |                                |                         |                           |
|--------------------------------|-------------------------|---------------------------|
| 1. Front brake                 | 2. Input clutch         | 3. Direct clutch          |
| 4. High and low reverse clutch | 5. Reverse brake        | 6. Forward brake          |
| 7. Low coast brake             | 8. 1st one-way clutch   | 9. Forward one-way clutch |
| 10. 3rd one-way clutch         | 11. Front sun gear      | 12. Input shaft           |
| 13. Mid internal gear          | 14. Front internal gear | 15. Rear carrier          |
| 16. Rear sun gear              | 17. Mid sun gear        | 18. Front carrier         |
| 19. Mid carrier                | 20. Rear internal gear  | 21. Output shaft          |
| 22. Parking gear               | 23. Parking pawl        |                           |

## "M1" Position

- The front brake fastens the front sun gear.
- The forward brake and the forward one-way clutch regulate reverse rotation of the mid sun gear.
- High and low reverse clutch connects the rear sun gear and the mid sun gear.
- The low coast brake fastens the mid sun gear.
- During deceleration, the low coast brake regulates forward rotation of the mid sun gear and the engine brake functions.

# A/T CONTROL SYSTEM

< SERVICE INFORMATION >

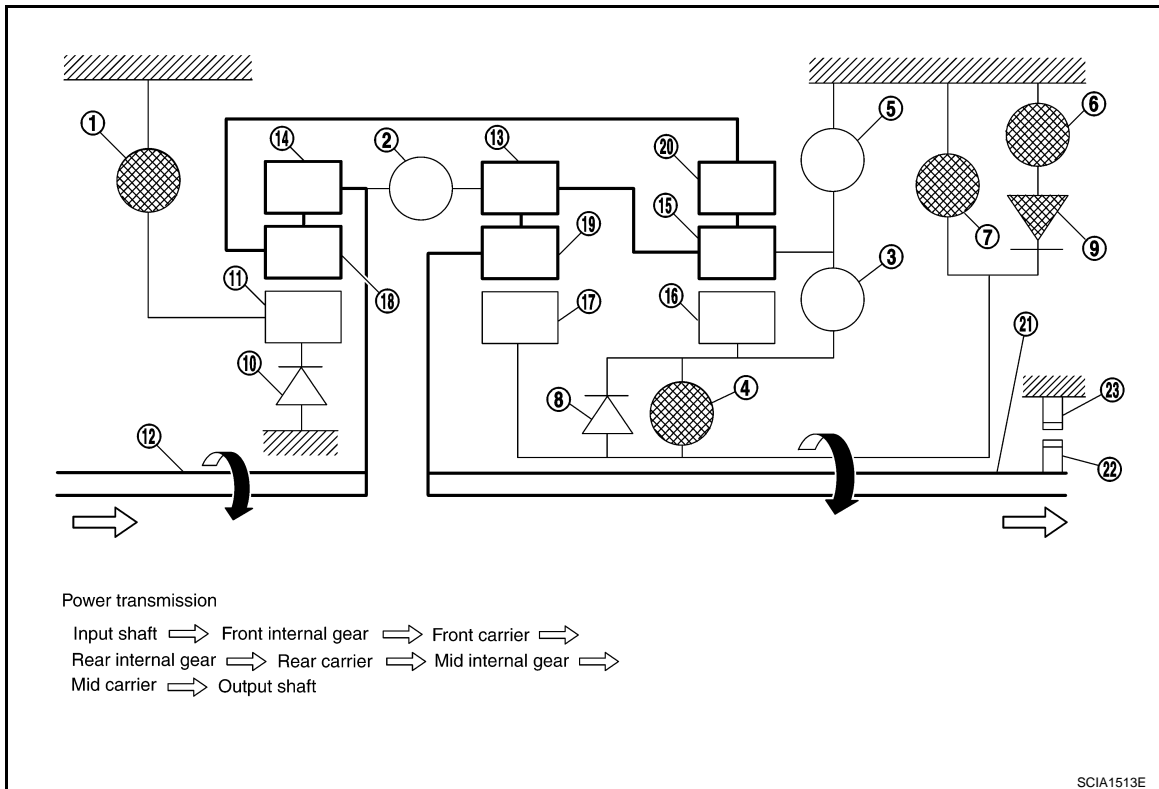

- |                                |                         |                           |
|--------------------------------|-------------------------|---------------------------|
| 1. Front brake                 | 2. Input clutch         | 3. Direct clutch          |
| 4. High and low reverse clutch | 5. Reverse brake        | 6. Forward brake          |
| 7. Low coast brake             | 8. 1st one-way clutch   | 9. Forward one-way clutch |
| 10. 3rd one-way clutch         | 11. Front sun gear      | 12. Input shaft           |
| 13. Mid internal gear          | 14. Front internal gear | 15. Rear carrier          |
| 16. Rear sun gear              | 17. Mid sun gear        | 18. Front carrier         |
| 19. Mid carrier                | 20. Rear internal gear  | 21. Output shaft          |
| 22. Parking gear               | 23. Parking pawl        |                           |

## “D2” Position

- The forward brake and the forward one-way clutch regulate reverse rotation of the mid sun gear.
- The 3rd one-way clutch regulates reverse rotation of the front sun gear.
- The direct clutch is coupled, and the rear carrier and rear sun gear are connected.
- During deceleration, the mid sun gear turns forward, so the forward one-way clutch idles and engine brake is not activated.

A  
B  
AT  
D  
E  
F  
G  
H  
I  
J  
K  
L  
M  
N  
O  
P

# A/T CONTROL SYSTEM

< SERVICE INFORMATION >

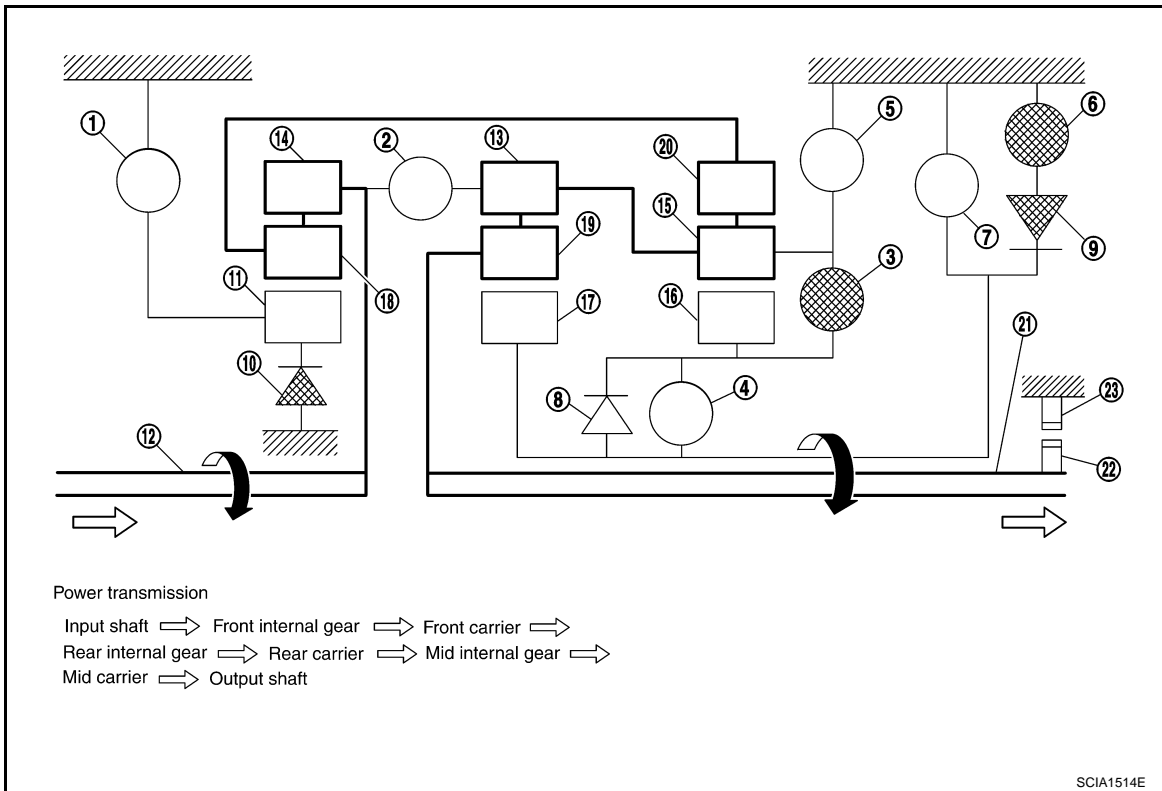

- |                                |                         |                           |
|--------------------------------|-------------------------|---------------------------|
| 1. Front brake                 | 2. Input clutch         | 3. Direct clutch          |
| 4. High and low reverse clutch | 5. Reverse brake        | 6. Forward brake          |
| 7. Low coast brake             | 8. 1st one-way clutch   | 9. Forward one-way clutch |
| 10. 3rd one-way clutch         | 11. Front sun gear      | 12. Input shaft           |
| 13. Mid internal gear          | 14. Front internal gear | 15. Rear carrier          |
| 16. Rear sun gear              | 17. Mid sun gear        | 18. Front carrier         |
| 19. Mid carrier                | 20. Rear internal gear  | 21. Output shaft          |
| 22. Parking gear               | 23. Parking pawl        |                           |

## "M2" Position

- The front brake fastens the front sun gear.
- The forward brake and the forward one-way clutch regulate reverse rotation of the mid sun gear.
- The direct clutch is coupled, and the rear carrier and rear sun gear are connected.
- The low coast brake fastens the mid sun gear.
- During deceleration, the low coast brake regulates forward rotation of the mid sun gear and the engine brake functions.



# A/T CONTROL SYSTEM

< SERVICE INFORMATION >

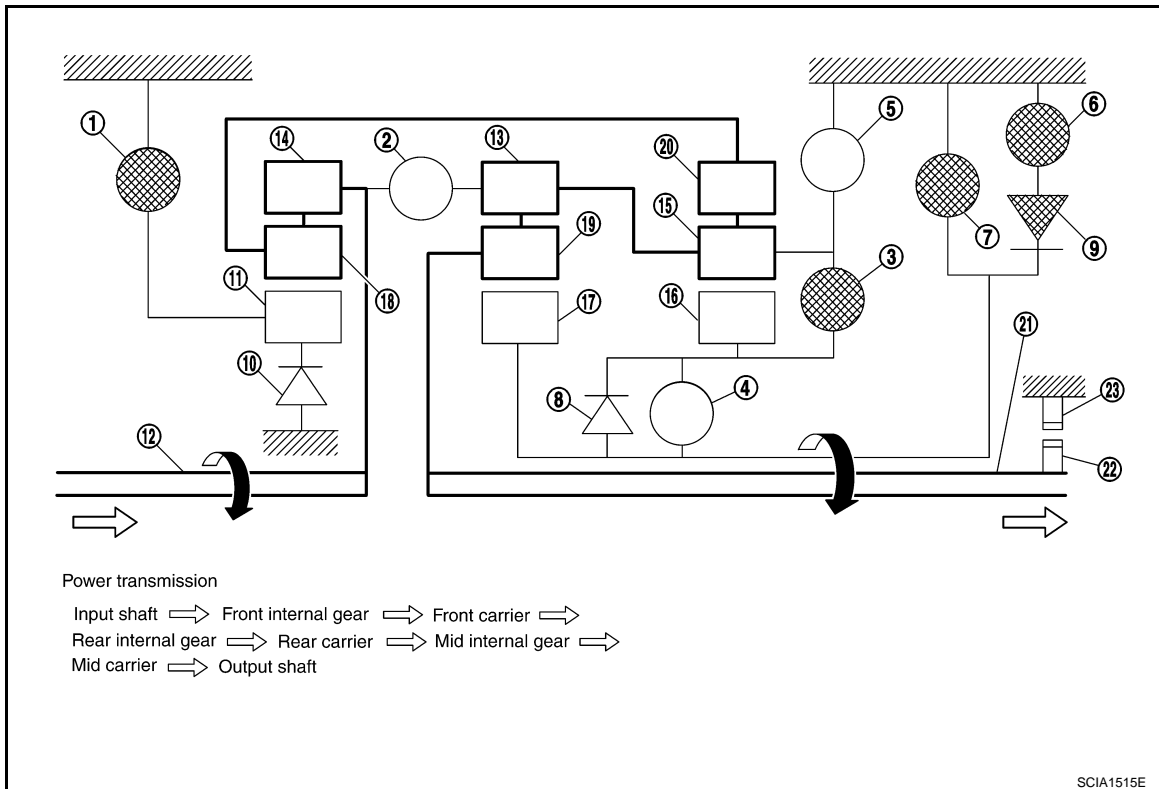

- |                                |                         |                           |
|--------------------------------|-------------------------|---------------------------|
| 1. Front brake                 | 2. Input clutch         | 3. Direct clutch          |
| 4. High and low reverse clutch | 5. Reverse brake        | 6. Forward brake          |
| 7. Low coast brake             | 8. 1st one-way clutch   | 9. Forward one-way clutch |
| 10. 3rd one-way clutch         | 11. Front sun gear      | 12. Input shaft           |
| 13. Mid internal gear          | 14. Front internal gear | 15. Rear carrier          |
| 16. Rear sun gear              | 17. Mid sun gear        | 18. Front carrier         |
| 19. Mid carrier                | 20. Rear internal gear  | 21. Output shaft          |
| 22. Parking gear               | 23. Parking pawl        |                           |

## “D3” and “M3” Positions

- The front brake fastens the front sun gear.
- The direct clutch is coupled, and the rear carrier and rear sun gear are connected.
- The high and low reverse clutch is coupled, and the mid sun gear and rear sun gear are connected.

A  
B  
AT  
D  
E  
F  
G  
H  
I  
J  
K  
L  
M  
N  
O  
P

# A/T CONTROL SYSTEM

< SERVICE INFORMATION >

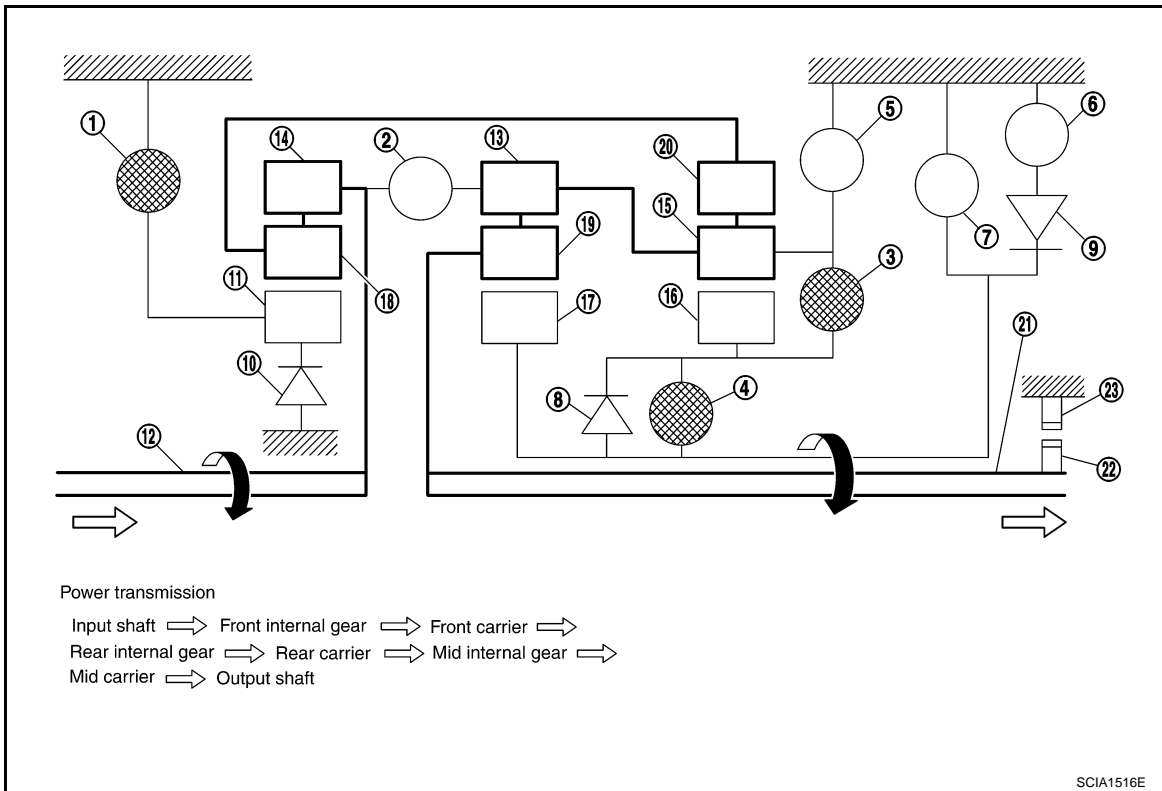

- |                                |                         |                           |
|--------------------------------|-------------------------|---------------------------|
| 1. Front brake                 | 2. Input clutch         | 3. Direct clutch          |
| 4. High and low reverse clutch | 5. Reverse brake        | 6. Forward brake          |
| 7. Low coast brake             | 8. 1st one-way clutch   | 9. Forward one-way clutch |
| 10. 3rd one-way clutch         | 11. Front sun gear      | 12. Input shaft           |
| 13. Mid internal gear          | 14. Front internal gear | 15. Rear carrier          |
| 16. Rear sun gear              | 17. Mid sun gear        | 18. Front carrier         |
| 19. Mid carrier                | 20. Rear internal gear  | 21. Output shaft          |
| 22. Parking gear               | 23. Parking pawl        |                           |

## “D4” and “M4” Positions

- The direct clutch is coupled, and the rear carrier and rear sun gear are connected.
- The high and low reverse clutch is coupled, and the mid sun gear and rear sun gear are connected.
- The input clutch is coupled, and the front internal gear and mid internal gear are connected.
- The drive power is conveyed to the front internal gear, mid internal gear, and rear carrier and the three planetary gears rotate forward as one unit.

# A/T CONTROL SYSTEM

< SERVICE INFORMATION >

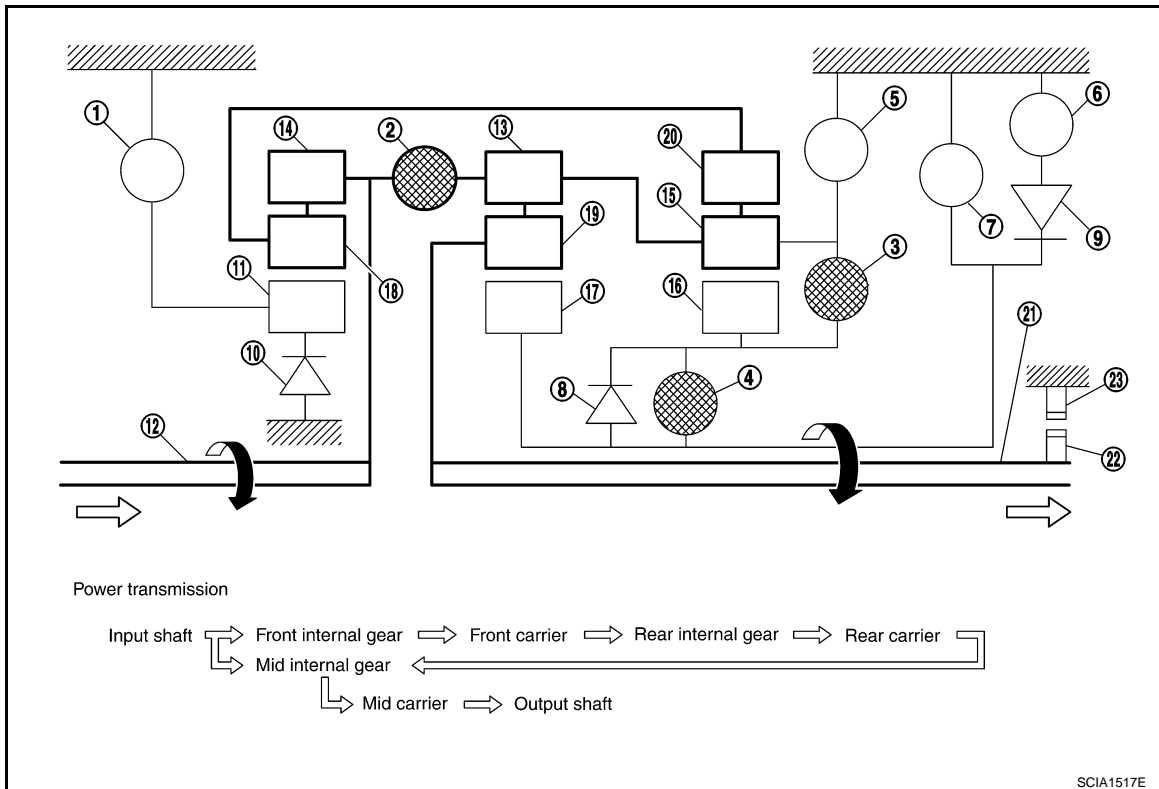

- |                                |                         |                           |
|--------------------------------|-------------------------|---------------------------|
| 1. Front brake                 | 2. Input clutch         | 3. Direct clutch          |
| 4. High and low reverse clutch | 5. Reverse brake        | 6. Forward brake          |
| 7. Low coast brake             | 8. 1st one-way clutch   | 9. Forward one-way clutch |
| 10. 3rd one-way clutch         | 11. Front sun gear      | 12. Input shaft           |
| 13. Mid internal gear          | 14. Front internal gear | 15. Rear carrier          |
| 16. Rear sun gear              | 17. Mid sun gear        | 18. Front carrier         |
| 19. Mid carrier                | 20. Rear internal gear  | 21. Output shaft          |
| 22. Parking gear               | 23. Parking pawl        |                           |

## "D5" and "M5" Positions

- The front brake fastens the front sun gear.
- The input clutch is coupled, and the front internal gear and mid internal gear are connected.
- The high and low reverse clutch is coupled, and the mid sun gear and rear sun gear are connected.

A  
B  
AT  
D  
E  
F  
G  
H  
I  
J  
K  
L  
M  
N  
O  
P

# A/T CONTROL SYSTEM

< SERVICE INFORMATION >

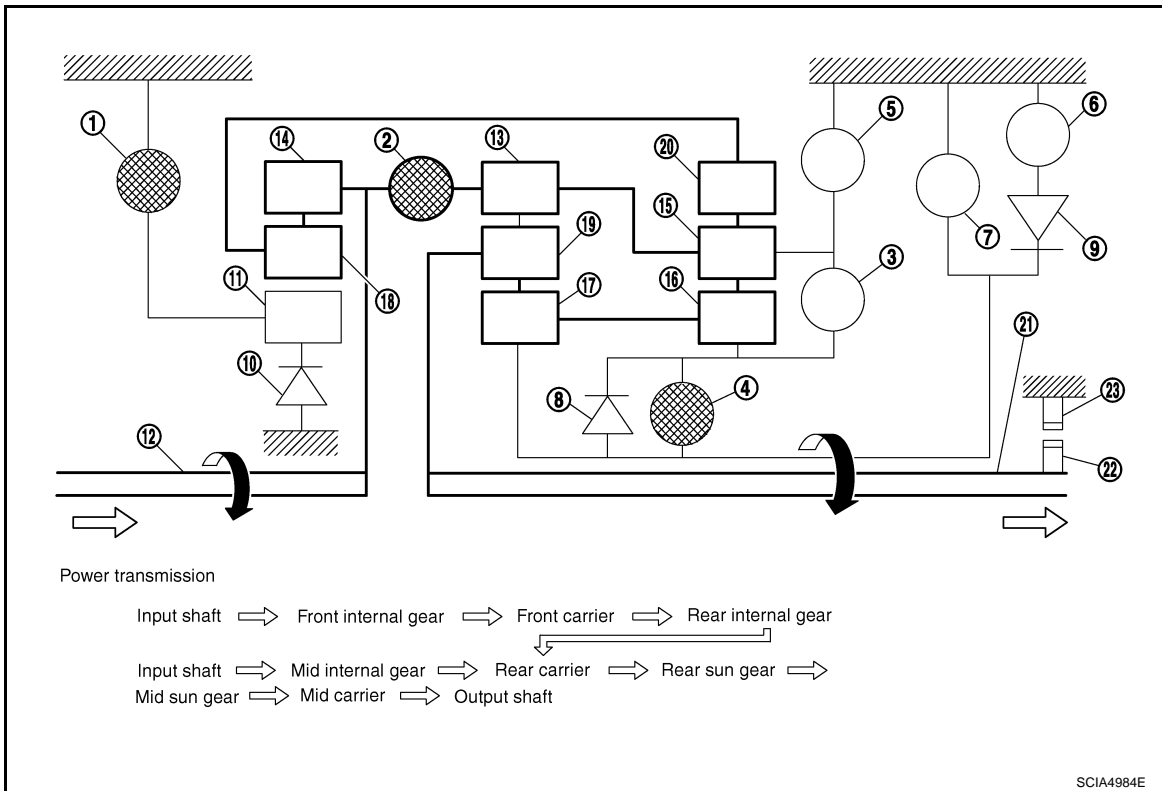

- |                                |                         |                           |
|--------------------------------|-------------------------|---------------------------|
| 1. Front brake                 | 2. Input clutch         | 3. Direct clutch          |
| 4. High and low reverse clutch | 5. Reverse brake        | 6. Forward brake          |
| 7. Low coast brake             | 8. 1st one-way clutch   | 9. Forward one-way clutch |
| 10. 3rd one-way clutch         | 11. Front sun gear      | 12. Input shaft           |
| 13. Mid internal gear          | 14. Front internal gear | 15. Rear carrier          |
| 16. Rear sun gear              | 17. Mid sun gear        | 18. Front carrier         |
| 19. Mid carrier                | 20. Rear internal gear  | 21. Output shaft          |
| 22. Parking gear               | 23. Parking pawl        |                           |

## "R" Position

- The front brake fastens the front sun gear.
- The high and low reverse clutch is coupled, and the mid sun gear and rear sun gear are connected.
- The reverse brake fastens the rear carrier.

# A/T CONTROL SYSTEM

< SERVICE INFORMATION >

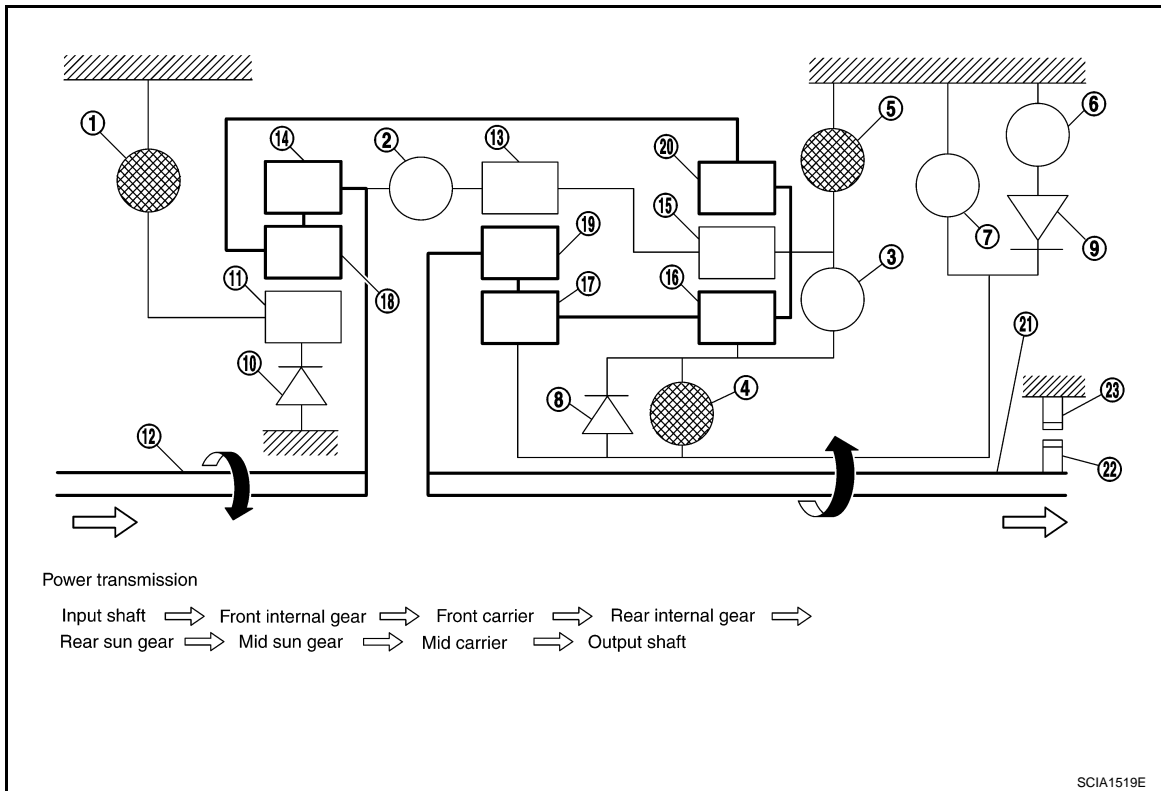

- |                                |                         |                           |
|--------------------------------|-------------------------|---------------------------|
| 1. Front brake                 | 2. Input clutch         | 3. Direct clutch          |
| 4. High and low reverse clutch | 5. Reverse brake        | 6. Forward brake          |
| 7. Low coast brake             | 8. 1st one-way clutch   | 9. Forward one-way clutch |
| 10. 3rd one-way clutch         | 11. Front sun gear      | 12. Input shaft           |
| 13. Mid internal gear          | 14. Front internal gear | 15. Rear carrier          |
| 16. Rear sun gear              | 17. Mid sun gear        | 18. Front carrier         |
| 19. Mid carrier                | 20. Rear internal gear  | 21. Output shaft          |
| 22. Parking gear               | 23. Parking pawl        |                           |

## TCM Function

INFOID:000000001327135

The function of the TCM is to:

- Receive input signals sent from various switches and sensors.
- Determine required line pressure, shifting point, lock-up operation, and engine brake operation.
- Send required output signals to the respective solenoids.

## CONTROL SYSTEM OUTLINE

The automatic transmission senses vehicle operating conditions through various sensors or signals. It always controls the optimum shift position and reduces shifting and lock-up shocks.

SENSORS (or SIGNALS)		TCM		ACTUATORS
PNP switch Accelerator pedal position signal Closed throttle position signal Wide open throttle position signal Engine speed signal A/T fluid temperature sensor Revolution sensor Vehicle speed signal Manual mode switch signal Stop lamp switch signal Turbine revolution sensor ATF pressure switch	⇒	Shift control Line pressure control Lock-up control Engine brake control Timing control Fail-safe control Self-diagnosis CONSULT-III communication line Duet-EA control CAN system	⇒	Input clutch solenoid valve Direct clutch solenoid valve Front brake solenoid valve High and low reverse clutch solenoid valve Low coast brake solenoid valve Torque converter clutch solenoid valve Line pressure solenoid valve A/T CHECK indicator lamp Starter relay Back-up lamp relay

# A/T CONTROL SYSTEM

< SERVICE INFORMATION >

## CONTROL SYSTEM DIAGRAM

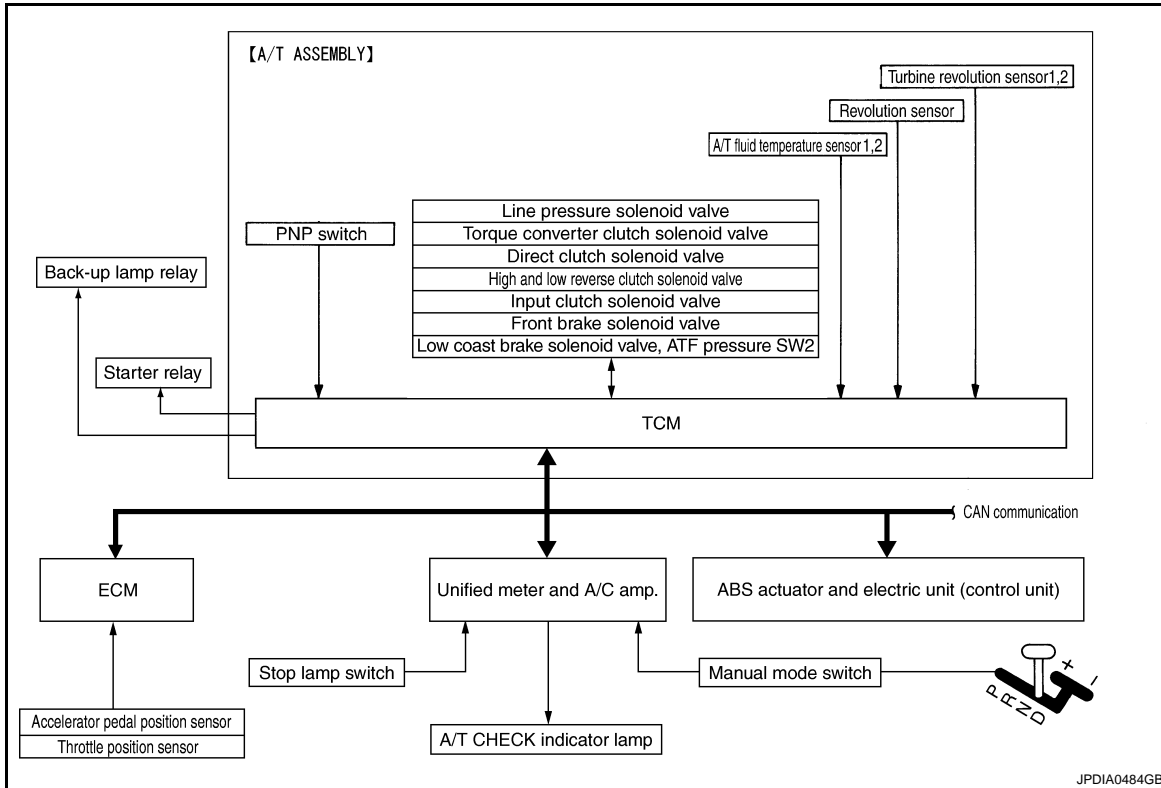

## CAN Communication

INFOID:000000001327136

## SYSTEM DESCRIPTION

CAN (Controller Area Network) is a serial communication line for real time application. It is an on-vehicle multiplex communication line with high data communication speed and excellent error detection ability. Many electronic control units are equipped onto a vehicle, and each control unit shares information and links with other control units during operation (not independent). In CAN communication, control units are connected with 2 communication lines (CAN-H line, CAN-L line) allowing a high rate of information transmission with less wiring. Each control unit transmits/receives data but selectively reads required data only. For details, refer to [LAN-43, "CAN System Specification Chart"](#).

# A/T CONTROL SYSTEM

< SERVICE INFORMATION >

## Input/Output Signal of TCM

INFOID:000000001327137

Control item		Line pressure control	Vehicle speed control	Shift control	Lock-up control	Engine brake control	Fail-safe function (*3)	Self-diagnostics function	
Input	Accelerator pedal position signal <sup>(*5)</sup>	X	X	X	X	X	X	X	
	Vehicle speed sensor A/T (revolution sensor)	X	X	X	X	X	X	X	
	Vehicle speed sensor MTR <sup>(*1)</sup> (*5)						X		
	Closed throttle position signal <sup>(*5)</sup>		X (*2)	X	X		X	X (*4)	
	Wide open throttle position signal <sup>(*5)</sup>						X	X (*4)	
	Turbine revolution sensor 1		X		X	X	X	X	
	Turbine revolution sensor 2 (for 4th speed only)		X		X	X	X	X	
	Engine speed signals <sup>(*5)</sup>	X	X	X	X	X	X	X	
	Stop lamp switch signal <sup>(*5)</sup>		X	X	X			X (*4)	
	A/T fluid temperature sensors 1, 2	X	X	X	X		X	X	
	ASCD or ICC	Operation signal <sup>(*5)</sup>		X	X	X			
		Overdrive cancel signal <sup>(*5)</sup>		X					
Output	Direct clutch solenoid		X	X			X	X	
	Input clutch solenoid		X	X			X	X	
	High and low reverse clutch solenoid		X	X			X	X	
	Front brake solenoid		X	X			X	X	
	Low coast brake solenoid (ATF pressure switch 2)		X	X		X	X	X	
	Line pressure solenoid	X	X	X	X	X	X	X	
	TCC solenoid				X		X	X	
	Self-diagnostics table <sup>(*6)</sup>							X	
	Starter relay						X	X	

\*1: Spare for vehicle speed sensor-A/T (revolution sensor)

\*2: Spare for accelerator pedal position signal

\*3: If these input and output signals are different, the TCM triggers the fail-safe function.

\*4: Used as a condition for starting self-diagnostics; if self-diagnostics are not started, it is judged that there is some kind of error.

\*5: Input by CAN communications

\*6: Output by CAN communications

## Line Pressure Control

INFOID:000000001327138

- When an input torque signal equivalent to the engine drive force is sent from the ECM to the TCM, the TCM controls the line pressure solenoid.

# A/T CONTROL SYSTEM

## < SERVICE INFORMATION >

- This line pressure solenoid controls the pressure regulator valve as the signal pressure and adjusts the pressure of the operating oil discharged from the oil pump to the line pressure most appropriate to the driving state.

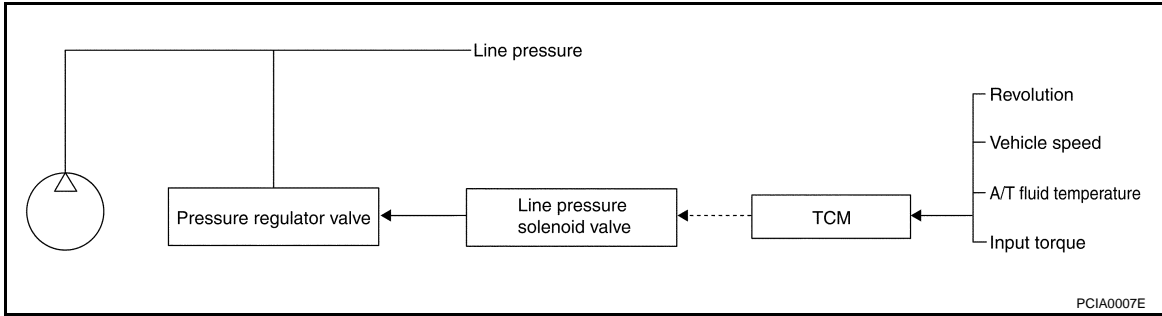

## LINE PRESSURE CONTROL IS BASED ON THE TCM LINE PRESSURE CHARACTERISTIC PATTERN

- The TCM has stored in memory a number of patterns for the optimum line pressure characteristic for the driving state.
- In order to obtain the most appropriate line pressure characteristic to meet the current driving state, the TCM controls the line pressure solenoid current valve and thus controls the line pressure.

### Normal Control

Each clutch is adjusted to the necessary pressure to match the engine drive force.

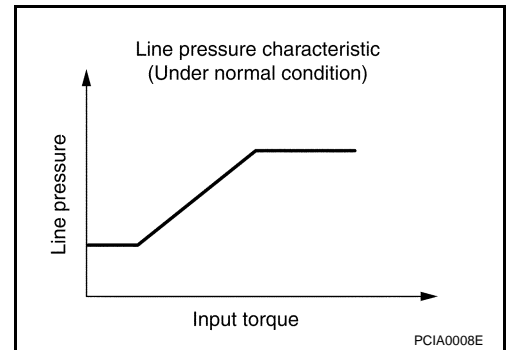

### Back-up Control (Engine Brake)

When the select operation is performed during driving and the transmission is shifted down, the line pressure is set according to the vehicle speed.

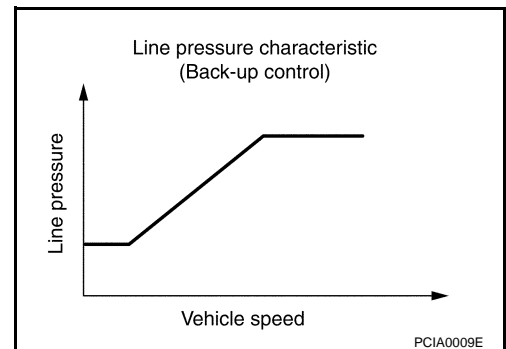

### During Shift Change



# A/T CONTROL SYSTEM

## < SERVICE INFORMATION >

The necessary and adequate line pressure for shift change is set. For this reason, line pressure pattern setting corresponds to input torque and gearshift selection. Also, line pressure characteristic is set according to engine speed, during engine brake operation.

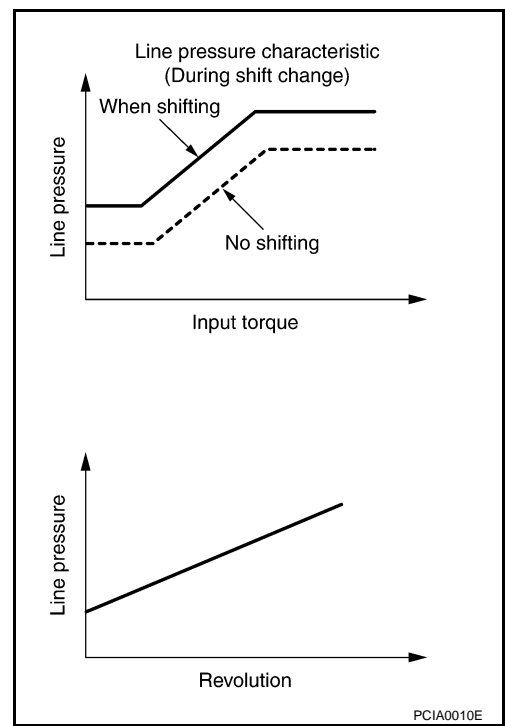

### At Low Fluid Temperature

When the A/T fluid temperature drops below the prescribed temperature, in order to speed up the action of each friction element, the line pressure is set higher than the normal line pressure characteristic.

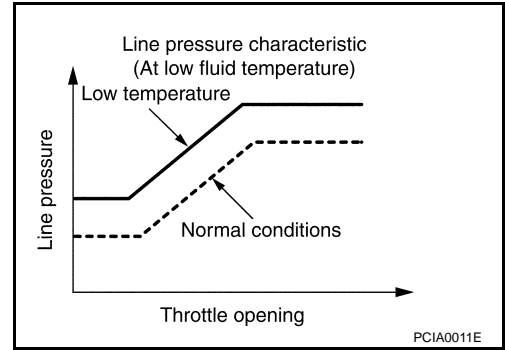

## Shift Control

INFOID:000000001327139

The clutch pressure control solenoid is controlled by the signals from the switches and sensors. Thus, the clutch pressure is adjusted to be appropriate to the engine load state and vehicle driving state. It becomes possible to finely control the clutch hydraulic pressure with high precision and a smoother shift change characteristic is attained.

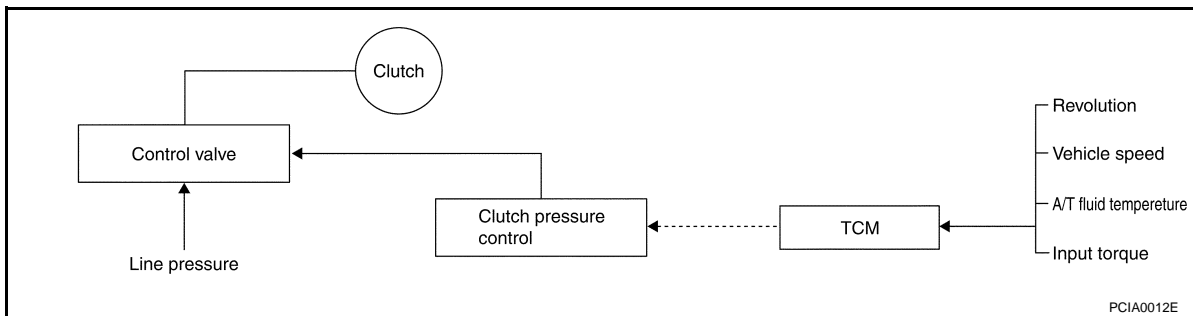

## SHIFT CHANGE

The clutch is controlled with the optimum timing and oil pressure by the engine speed, engine torque information, etc.

### Shift Change System Diagram

# A/T CONTROL SYSTEM

## < SERVICE INFORMATION >

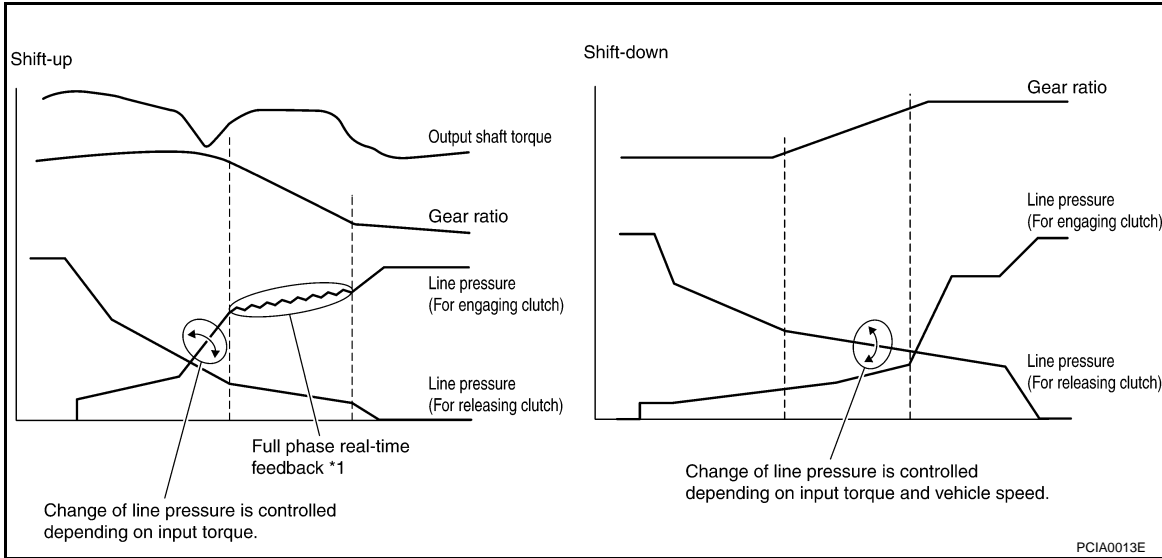

\*1: Full phase real-time feedback control monitors movement of gear ratio at gear change, and controls oil pressure at real-time to achieve the best gear ratio.

### BLIPPING CONTROL

This system makes transmission clutch engage readily by controlling (synchronizing) engine revolution according to the (calculation of) engine revolution after shifting down.

- “BLIPPING CONTROL” functions.
  - When downshifting by accelerator pedal depression at “D” position.
  - When downshifting under the manual mode.
- TCM selects “BLIPPING CONTROL” or “NORMAL SHIFT CONTROL” according to the gear position, the select lever position, the engine torque and the speed when accelerating by accelerator pedal depression.
- Revolution control demand signal is transmitted from TCM to ECM under “BLIPPING CONTROL”.
- TCM synchronizes engine revolution according to the revolution control demand signal.

### Shift Change System Diagram

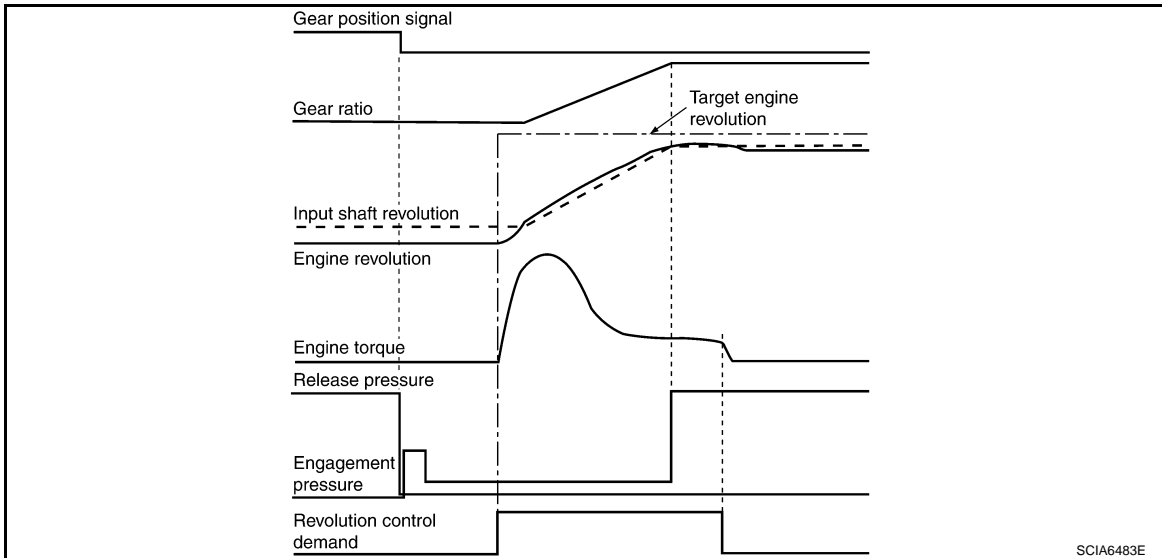

### Lock-up Control

INFOID:000000001327140

The torque converter clutch piston in the torque converter is engaged to eliminate torque converter slip to increase power transmission efficiency.

The torque converter clutch control valve operation is controlled by the torque converter clutch solenoid valve, which is controlled by a signal from TCM, and the torque converter clutch control valve engages or releases the torque converter clutch piston.

# A/T CONTROL SYSTEM

## < SERVICE INFORMATION >

Lock-up Operation Condition Table

selector lever	D position		M5 position	M4 position	M3 position
Gear position	5	4	5	4	3
Lock-up	×	–	×	×	×
Slip lock-up	×	×	–	–	–

## TORQUE CONVERTER CLUTCH CONTROL VALVE CONTROL

Lock-up Control System Diagram

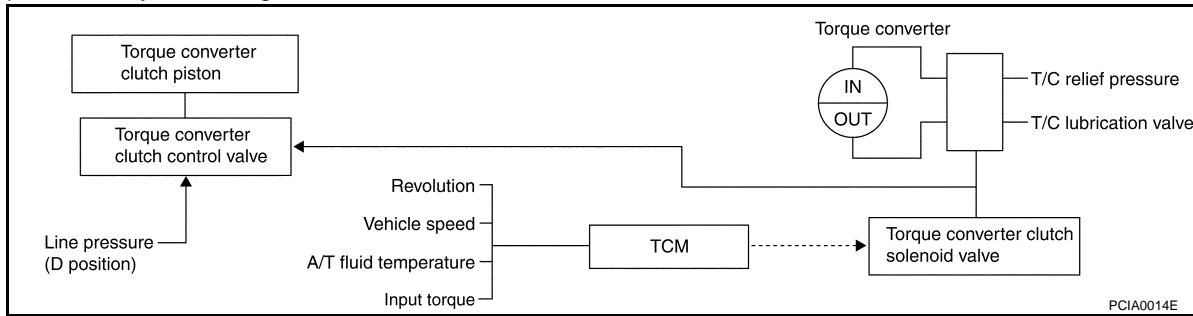

### Lock-up Released

In the lock-up released state, the torque converter clutch control valve is set into the unlocked state by the torque converter clutch solenoid and the lock-up apply pressure is drained. In this way, the torque converter clutch piston is not coupled.

### Lock-up Applied

In the lock-up applied state, the torque converter clutch control valve is set into the locked state by the torque converter clutch solenoid and lock-up apply pressure is generated. In this way, the torque converter clutch piston is pressed and coupled.

## SMOOTH LOCK-UP CONTROL

When shifting from the lock-up released state to the lock-up applied state, the current output to the torque converter clutch solenoid is controlled with the TCM. In this way, when shifting to the lock-up applied state, the torque converter clutch is temporarily set to the half-clutched state to reduce the shock.

### Half-clutched State

The current output from the TCM to the torque converter clutch solenoid is varied to gradually increase the torque converter clutch solenoid pressure. In this way, the lock-up apply pressure gradually rises and while the torque converter clutch piston is put into half-clutched status, the torque converter clutch piston operating pressure is increased and the coupling is completed smoothly.

### Slip Lock-up Control

In the slip region, the torque converter clutch solenoid current is controlled with the TCM to put it into the half-clutched state. This absorbs the engine torque fluctuation and lock-up operates from low speed.

## Engine Brake Control

INFOID:0000000001327141

- The forward one-way clutch transmits the drive force from the engine to the rear wheels. But the reverse drive from the rear wheels is not transmitted to the engine because the one-way clutch is idling.

# A/T CONTROL SYSTEM

## < SERVICE INFORMATION >

Therefore, the low coast brake solenoid is operated to prevent the forward one-way clutch from idling and the engine brake is operated in the same manner as conventionally.

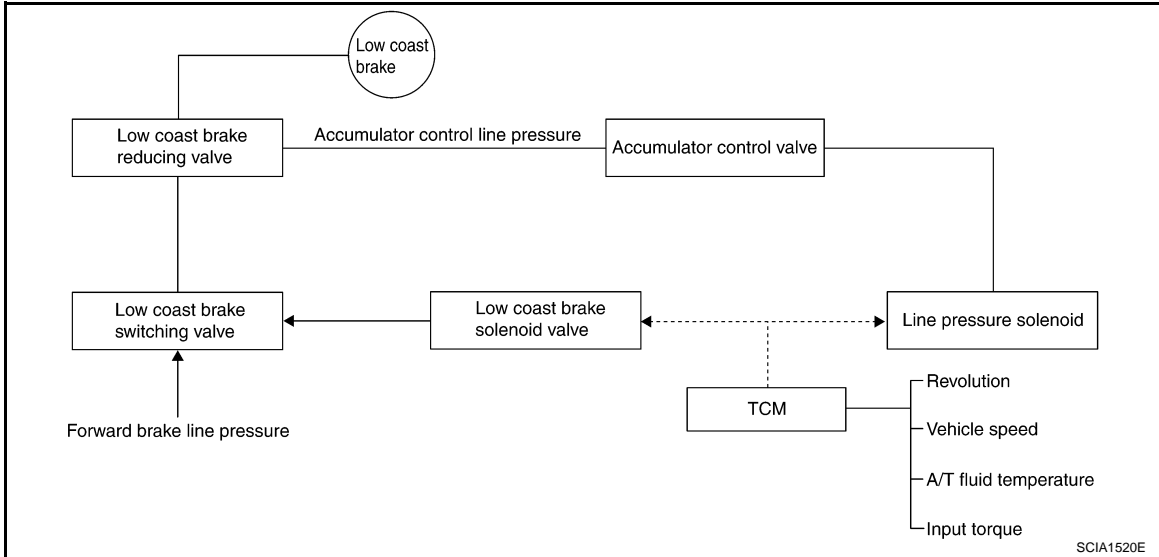

- The operation of the low coast brake solenoid switches the low coast brake switching valve and controls the coupling and releasing of the low coast brake.  
The low coast brake reducing valve controls the low coast brake coupling force.

## Control Valve

INFOID:000000001327142

### FUNCTION OF CONTROL VALVE

Name	Function
Torque converter regulator valve	In order to prevent the pressure supplied to the torque converter from being excessive, the line pressure is adjusted to the optimum pressure (torque converter operating pressure).
Pressure regulator valve Pressure regulator plug Pressure regulator sleeve	Adjusts the oil discharged from the oil pump to the optimum pressure (line pressure) for the driving state.
Front brake control valve	When the front brake is coupled, adjusts the line pressure to the optimum pressure (front brake pressure) and supplies it to the front brake. (In 1st, 2nd, 3rd, and 5th gears, adjusts the clutch pressure.)
Accumulator control valve	Adjusts the pressure (accumulator control pressure) acting on the accumulator piston and low coast reducing valve to the pressure appropriate to the driving state.
Pilot valve A	Adjusts the line pressure and produces the constant pressure (pilot pressure) required for line pressure control, shift change control, and lock-up control.
Pilot valve B	Adjusts the line pressure and produces the constant pressure (pilot pressure) required for shift change control.
Low coast brake switching valve	During engine braking, supplies the line pressure to the low coast brake reducing valve.
Low coast brake reducing valve	When the low coast brake is coupled, adjusts the line pressure to the optimum pressure (low coast brake pressure) and supplies it to the low coast brake.
N-R accumulator	Produces the stabilizing pressure for when N-R is selected.
Direct clutch piston switching valve	Operates in 4th gear and switches the direct clutch coupling capacity.
High and low reverse clutch control valve	When the high and low reverse clutch is coupled, adjusts the line pressure to the optimum pressure (high and low reverse clutch pressure) and supplies it to the high and low reverse clutch. (In 1st, 3rd, 4th and 5th gears, adjusts the clutch pressure.)
Input clutch control valve	When the input clutch is coupled, adjusts the line pressure to the optimum pressure (input clutch pressure) and supplies it to the input clutch. (In 4th and 5th gears, adjusts the clutch pressure.)
Direct clutch control valve	When the direct clutch is coupled, adjusts the line pressure to the optimum pressure (direct clutch pressure) and supplies it to the direct clutch. (In 2nd, 3rd, and 4th gears, adjusts the clutch pressure.)

# A/T CONTROL SYSTEM

## < SERVICE INFORMATION >

Name	Function
TCC control valve TCC control plug TCC control sleeve	Switches the lock-up to operating or released. Also, by performing the lock-up operation transiently, lock-up smoothly.
Torque converter lubrication valve	Operates during lock-up to switch the torque converter, cooling, and lubrication system oil passage.
Cool bypass valve	Allows excess oil to bypass cooler circuit without being fed into it.
Line pressure relief valve	Discharges excess oil from line pressure circuit.
N-D accumulator	Produces the stabilizing pressure for when N-D is selected.
Manual valve	Sends line pressure to each circuit according to the select position. The circuits to which the line pressure is not sent drain.

## FUNCTION OF ATF PRESSURE SWITCH

Name	Function
ATF pressure switch 2 (LC/B)	Detects any malfunction in the low coast brake hydraulic pressure. When it detects any malfunction, it puts the system into fail-safe mode.

A  
B  
AT  
D  
E  
F  
G  
H  
I  
J  
K  
L  
M  
N  
O  
P

# ON BOARD DIAGNOSTIC (OBD) SYSTEM

< SERVICE INFORMATION >

## ON BOARD DIAGNOSTIC (OBD) SYSTEM

### Introduction

INFOID:000000001327143

The A/T system has two self-diagnostic systems.

The first is the emission-related on board diagnostic system (OBD-II) performed by the TCM in combination with the ECM. The malfunction is indicated by the MIL (malfunction indicator lamp) and is stored as a DTC in the ECM memory but not the TCM memory.

The second is the TCM original self-diagnosis indicated by the A/T CHECK indicator lamp. The malfunction is stored in the TCM memory. The detected items are overlapped with OBD-II self-diagnostic items. For detail, refer to [AT-84, "CONSULT-III Function \(TRANSMISSION\)"](#).

### OBD-II Function for A/T System

INFOID:000000001327144

The ECM provides emission-related on board diagnostic (OBD-II) functions for the A/T system. One function is to receive a signal from the TCM used with OBD-related parts of the A/T system. The signal is sent to the ECM when a malfunction occurs in the corresponding OBD-related part. The other function is to indicate a diagnostic result by means of the MIL (malfunction indicator lamp) on the instrument panel. Sensors, switches and solenoid valves are used as sensing elements.

The MIL automatically illuminates in "One or Two Trip Detection Logic" when a malfunction is sensed in relation to A/T system parts.

### One or Two Trip Detection Logic of OBD-II

INFOID:000000001327145

#### ONE TRIP DETECTION LOGIC

If a malfunction is sensed during the first test drive, the MIL will illuminate and the malfunction will be stored in the ECM memory as a DTC. The TCM is not provided with such a memory function.

#### TWO TRIP DETECTION LOGIC

When a malfunction is sensed during the first test drive, it is stored in the ECM memory as a 1st trip DTC (diagnostic trouble code) or 1st trip freeze frame data. At this point, the MIL will not illuminate. — 1st trip

If the same malfunction as that experienced during the first test drive is sensed during the second test drive, the MIL will illuminate. — 2nd trip

The "Trip" in the "One or Two Trip Detection Logic" means a driving mode in which self-diagnosis is performed during vehicle operation.

### OBD-II Diagnostic Trouble Code (DTC)

INFOID:000000001327146

#### HOW TO READ DTC AND 1ST TRIP DTC

DTC and 1st trip DTC can be read by the following methods.

( with **CONSULT-III** or ( **GST**) CONSULT-III or GST (Generic Scan Tool) Examples: P0705, P0720 etc.

These DTC are prescribed by SAE J2012.

(CONSULT-III also displays the malfunctioning component or system.)

- **1st trip DTC No. is the same as DTC No.**
- **Output of the diagnostic trouble code indicates that the indicated circuit has a malfunction. However, in case of the Mode II and GST, they do not indicate whether the malfunction is still occurring or occurred in the past and returned to normal.**  
**CONSULT-III can identify them as shown below, therefore, CONSULT-III (if available) is recommended.**

- DTC or 1st trip DTC of malfunction is displayed in SELF-DIAGNOSTIC RESULTS mode for "ENGINE" with CONSULT-III. Time data indicates how many times the vehicle was driven after the last detection of a DTC.

- If the DTC is being detected currently, the time data will be "0".

- If a 1st trip DTC is stored in the ECM, the time data will be "1".

#### Freeze Frame Data and 1st Trip Freeze Frame Data

The ECM has a memory function, which stores the driving condition such as fuel system status, calculated load value, engine coolant temperature, short term fuel trim, long term fuel trim, engine speed and vehicle speed at the moment the ECM detects a malfunction.

Data which are stored in the ECM memory, along with the 1st trip DTC, are called 1st trip freeze frame data, and the data, stored together with the DTC data, are called freeze frame data and displayed on CONSULT-III or GST. The 1st trip freeze frame data can only be displayed on the CONSULT-III screen, not on the GST. For

# ON BOARD DIAGNOSTIC (OBD) SYSTEM

## < SERVICE INFORMATION >

detail, refer to [EC-117, "CONSULT-III Function \(ENGINE\)"](#) (for VQ35DE) or [EC-695, "CONSULT-III Function \(ENGINE\)"](#) (for VK45DE).

Only one set of freeze frame data (either 1st trip freeze frame data of freeze frame data) can be stored in the ECM. 1st trip freeze frame data is stored in the ECM memory along with the 1st trip DTC. There is no priority for 1st trip freeze frame data and it is updated each time a different 1st trip DTC is detected. However, once freeze frame data (2nd trip detection/MIL on) is stored in the ECM memory, 1st trip freeze frame data is no longer stored. Remember, only one set of freeze frame data can be stored in the ECM. The ECM has the following priorities to update the data.

Priority	Items	
1	Freeze frame data	Misfire — DTC: P0300 - P0306 Fuel Injection System Function — DTC: P0171, P0172, P0174, P0175
2		Except the above items (Includes A/T related items)
3	1st trip freeze frame data	

Both 1st trip freeze frame data and freeze frame data (along with the DTC) are cleared when the ECM memory is erased.

### HOW TO ERASE DTC

The diagnostic trouble code can be erased by CONSULT-III, GST or ECM DIAGNOSTIC TEST MODE as described following.

- **If the battery cable is disconnected, the diagnostic trouble code will be lost within 24 hours.**
- **When you erase the DTC, using CONSULT-III or GST is easier and quicker than switching the mode selector on the ECM.**

The following emission-related diagnostic information is cleared from the ECM memory when erasing DTC related to OBD-II. For details, refer to [EC-55, "Emission-Related Diagnostic Information"](#) (for VQ35DE) or [EC-633, "Emission-related Diagnostic Information"](#) (for VK45DE).

- **Diagnostic trouble codes (DTC)**
- **1st trip diagnostic trouble codes (1st trip DTC)**
- **Freeze frame data**
- **1st trip freeze frame data**
- **System readiness test (SRT) codes**
- **Test values**

#### HOW TO ERASE DTC (WITH CONSULT-III)

1. The emission related diagnostic information in the TCM and ECM can be erased by selecting "ALL Erase" in the "Description" of "FINAL CHECK" mode with CONSULT-III.

#### HOW TO ERASE DTC (WITH GST)

1. If the ignition switch stays ON after repair work, be sure to turn ignition switch OFF once. Wait at least 10 seconds and then turn it ON (engine stopped) again.
2. Perform "TCM SELF-DIAGNOSTIC PROCEDURE (No Tools)". Refer to [AT-91, "Diagnosis Procedure without CONSULT-III"](#). (The engine warm-up step can be skipped when performing the diagnosis only to erase the DTC.)
3. Select Mode 4 with Generic Scan Tool (GST). For details, refer to [EC-125, "Generic Scan Tool \(GST\) Function"](#) (for VQ35DE) or [EC-704, "Generic Scan Tool \(GST\) Function"](#) (for VK45DE).

#### HOW TO ERASE DTC (NO TOOLS)

The A/T CHECK indicator lamp is located on the instrument panel.

1. If the ignition switch stays ON after repair work, be sure to turn ignition switch OFF once. Wait at least 10 seconds and then turn it ON (engine stopped) again.
2. Perform "TCM SELF-DIAGNOSTIC PROCEDURE (No Tools)". Refer to [AT-91, "Diagnosis Procedure without CONSULT-III"](#). (The engine warm-up step can be skipped when performing the diagnosis only to erase the DTC.)
3. Perform "OBD-II SELF-DIAGNOSTIC PROCEDURE (No tools)". Refer to [EC-55, "Emission-Related Diagnostic Information"](#) (for VQ35DE) or [EC-633, "Emission-related Diagnostic Information"](#) (for VK45DE).

# ON BOARD DIAGNOSTIC (OBD) SYSTEM

< SERVICE INFORMATION >

## Malfunction Indicator Lamp (MIL)

INFOID:000000001327147

### DESCRIPTION

The MIL is located on the instrument panel.

1. The MIL will light up when the ignition switch is turned ON without the engine running. This is a bulb check.
  - If the MIL does not light up, refer to [DI-34](#), or see [EC-591](#) (for VQ35DE) or [EC-1194](#) (for VK45DE).
2. When the engine is started, the MIL should go off.  
If the MIL remains on, the on board diagnostic system has detected an engine system malfunction.

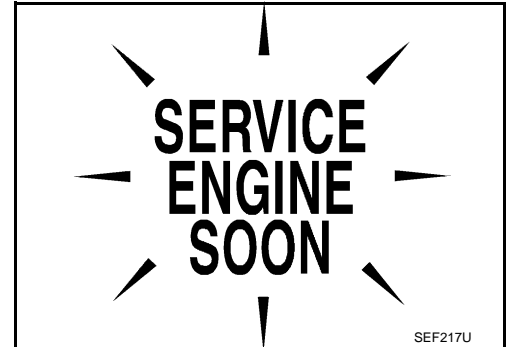



# TROUBLE DIAGNOSIS

< SERVICE INFORMATION >

## TROUBLE DIAGNOSIS

### DTC Inspection Priority Chart

INFOID:000000001327148

If some DTCs are displayed at the same time, perform inspections one by one based on the following priority chart.

**NOTE:**

If “DTC U1000” is displayed with other DTCs, first perform the trouble diagnosis for “DTC U1000 CAN COMMUNICATION”. Refer to [AT-94](#).

Priority	Detected items (DTC)
1	U1000 CAN communication line
2	Except above

### Fail-Safe

INFOID:000000001327149

The TCM has an electrical fail-safe mode. This mode makes it possible to operate even if there is an error in a main electronic control input/output signal circuit.

In fail-safe mode, even if the selector lever is “D” or “M” mode, the transmission is fixed in 2nd, 4th or 5th (depending on the breakdown position), so the customer should feel “slipping” or “poor acceleration”.

Even when the electronic circuits are normal, under special conditions (for example, when slamming on the brake with the wheels spinning drastically and stopping the tire rotation), the transmission can go into fail-safe mode. If this happens, switch OFF the ignition switch for 10 seconds, then switch it ON again to return to the normal shift pattern. Therefore, the customer's vehicle has returned to normal, so handle according to the “WORK FLOW” (Refer to [AT-42](#)).

#### FAIL-SAFE FUNCTION

If any malfunction occurs in a sensor or solenoid, this function controls the A/T to mark driving possible.

##### Vehicle Speed Sensor

Signals are input from two systems - from vehicle speed sensor A/T (revolution sensor) installed on the transmission and from combination meter so normal driving is possible even if there is a malfunction in one of the systems. And if vehicle speed sensor A/T (revolution sensor) has unusual cases, 5th gear and manual mode are prohibited.

##### Accelerator Pedal Position Sensor

If there is a malfunction in one of the systems, the accelerator opening angle is controlled by ECM according to a pre-determined accelerator angle to make driving possible. And if there are malfunctions in tow systems, the engine speed is fixed by ECM to a pre-determined engine speed to make driving possible.

##### Throttle Position Sensor

If there is a malfunction in one of the systems, the accelerator opening angle is controlled by ECM according to a pre-determined accelerator angle to make driving possible. And if there are malfunctions in tow systems, the accelerator opening angle is controlled by the idle signal sent from the ECM which is based on input indicating either idle condition or off-idle condition (pre-determined accelerator opening) in order to make driving possible.

##### PNP Switch

In the unlikely event that a malfunction signal enters the TCM, the position indicator is switched OFF, the starter relay is switched OFF (starter starting is disabled), the back-up lamp relay switched OFF (back-up lamp is OFF) and the position is fixed to the “D” position to make driving possible.

##### Starter Relay

The starter relay is switched OFF. (Starter starting is disabled.)

##### A/T Interlock

- If there is an A/T interlock judgment malfunction, the A/T is fixed in 2nd gear to make driving possible.

**NOTE:**

**When the vehicle is driven fixed in 2nd gear, a turbine revolution sensor malfunction is displayed, but this is not a turbine revolution sensor malfunction.**

- When the coupling pattern below is detected, the fail-safe action corresponding to the pattern is performed.

##### A/T 1st Engine Braking

# TROUBLE DIAGNOSIS

## < SERVICE INFORMATION >

When there is an A/T first gear engine brake judgment malfunction, the low coast brake solenoid is switched OFF to avoid the engine brake operation.

### Line Pressure Solenoid

The solenoid is switched OFF and the line pressure is set to the maximum hydraulic pressure to make driving possible.

### Torque Converter Clutch Solenoid

The solenoid is switched OFF to release the lock-up.

### Low Coast Brake Solenoid

When a malfunction (electrical or functional) occurs, in order to make driving possible, if the solenoid is ON, the transmission is held in 2nd gear; if the solenoid is OFF, the A/T is held in 4th gear. (Engine brake is not applied in 1st and 2nd gear.)

### Input Clutch Solenoid

If a malfunction (electrical or functional) occurs with the solenoid either ON or OFF, the A/T is held in 4th gear to make driving possible.

### Direct Clutch Solenoid

If a malfunction (electrical or functional) occurs with the solenoid either ON or OFF, the A/T is held in 4th gear to make driving possible.

### Front Brake Solenoid

If a malfunction (electrical or functional) occurs with the solenoid ON, in order to make driving possible, the A/T is held in 5th gear; if the solenoid is OFF, 4th gear.

### High and Low Reverse Clutch Solenoid

If a malfunction (electrical or functional) occurs with the solenoid either ON or OFF, the A/T is held in 4th gear to make driving possible.

### Turbine Revolution Sensor 1 or 2

The control is the same as if there were no turbine revolution sensors, 5th gear and manual mode are prohibited.

## How to Perform Trouble Diagnosis for Quick and Accurate Repair

INFOID:000000001327150

### INTRODUCTION

The TCM receives a signal from the vehicle speed sensor, accelerator pedal position sensor (throttle position sensor) or PNP switch and provides shift control or lock-up control via A/T solenoid valves.

The TCM also communicates with the ECM by means of a signal sent from sensing elements used with the OBD-related parts of the A/T system for malfunction-diagnostic purposes. The TCM is capable of diagnosing malfunctioning parts while the ECM can store malfunctions in its memory.

Input and output signals must always be correct and stable in the operation of the A/T system. The A/T system must be in good operating condition and be free of valve seizure, solenoid valve malfunction, etc.

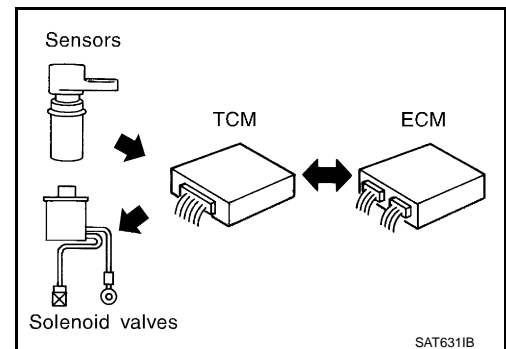

It is much more difficult to diagnose a error that occurs intermittently rather than continuously. Most intermittent errors are caused by poor electric connections or improper wiring. In this case, careful checking of suspected circuits may help prevent the replacement of good parts.

A visual check only may not find the cause of the errors. A road test with CONSULT-III (or GST) or a circuit tester connected should be performed. Follow the "WORK FLOW".

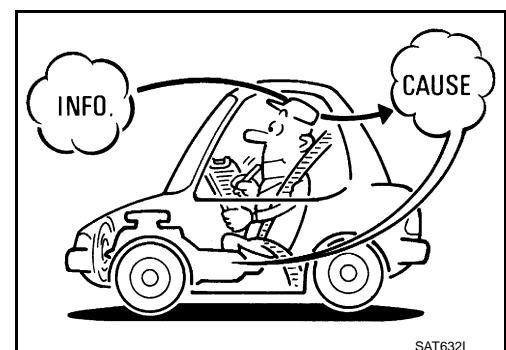

# TROUBLE DIAGNOSIS

## < SERVICE INFORMATION >

Before undertaking actual checks, take a few minutes to talk with a customer who approaches with a driveability complaint. The customer can supply good information about such errors, especially intermittent ones. Find out what symptoms are present and under what conditions they occur. A "DIAGNOSTIC WORKSHEET" as shown on the example (Refer to "Diagnostic Worksheet Chart") should be used.

Start your diagnosis by looking for "conventional" errors first. This will help troubleshoot driveability errors on an electronically controlled engine vehicle.

Also check related Service bulletins.

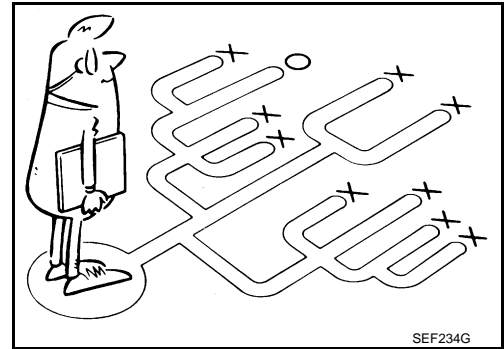

### WORK FLOW

A good understanding of the malfunction conditions can make troubleshooting faster and more accurate.

In general, each customer feels differently about a malfunction. It is important to fully understand the symptoms or conditions for a customer complaint.

Make good use of the two sheets provided, "Information from Customer" and "Diagnostic worksheet chart", to perform the best troubleshooting possible.

Work Flow Chart

A  
B  
AT  
D  
E  
F  
G  
H  
I  
J  
K  
L  
M  
N  
O  
P

# TROUBLE DIAGNOSIS

## < SERVICE INFORMATION >

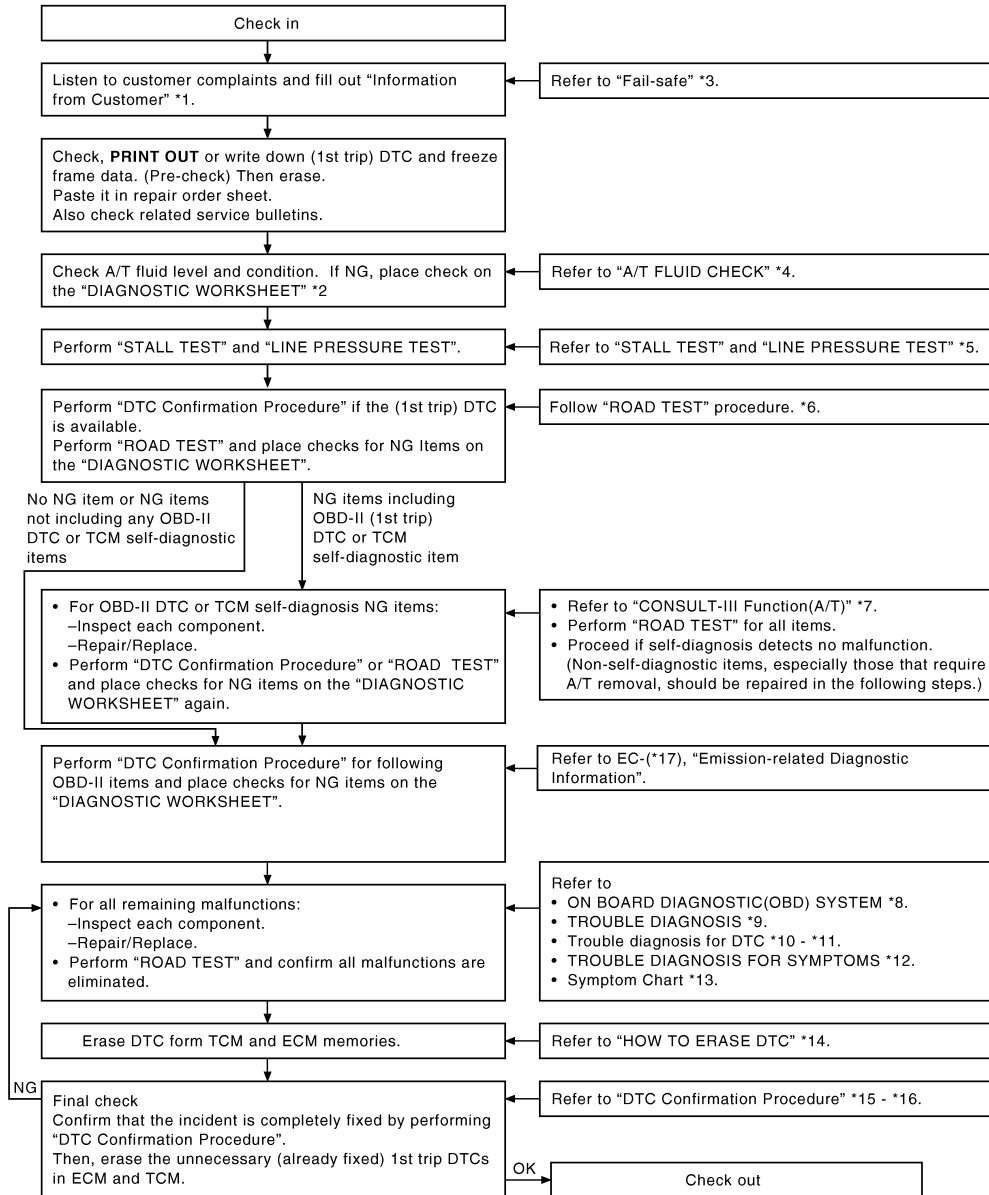

SCIA8466E

- |                                 |  |                             |
|---------------------------------|--|-----------------------------|
| *1. "Information from Customer" | *2. "Diagnostic Worksheet Chart"   | *3. <a href="#">AT-41</a>   |
| *4. <a href="#">AT-49</a>       | *5. <a href="#">AT-49</a> , <a href="#">AT-49</a>                              | *6. <a href="#">AT-49</a>   |
| *7. <a href="#">AT-84</a>       | *8. <a href="#">AT-38</a>  | *9. <a href="#">AT-41</a>   |
| *10. <a href="#">AT-94</a>      | *11. <a href="#">AT-155</a>  | *12. <a href="#">AT-167</a> |
| *13. <a href="#">AT-59</a>      | *14. <a href="#">AT-38</a>   | *15. <a href="#">AT-94</a>  |
| *16. <a href="#">AT-155</a>     | *17. <a href="#">EC-55</a> (for VQ35DE) or <a href="#">EC-633</a> (for VK45DE) |                             |

## DIAGNOSTIC WORKSHEET

### Information from Customer

#### KEY POINTS

- **WHAT**..... Vehicle and A/T model
- **WHEN**..... Date, Frequencies
- **WHERE**..... Road conditions
- **HOW**..... Operating conditions, Symptoms



# TROUBLE DIAGNOSIS

## < SERVICE INFORMATION >

	<input type="checkbox"/> Perform all road tests and enter checks in required inspection items.	<a href="#">AT-49</a>
4	4-1. Check before engine is started	<a href="#">AT-53</a>
	<input type="checkbox"/> The A/T CHECK Indicator Lamp does come on. <a href="#">AT-170</a> . <input type="checkbox"/> Perform self-diagnostics. Enter checks for detected items. <a href="#">AT-84</a> , <a href="#">AT-91</a> .	
	<input type="checkbox"/> DTC U1000 CAN COMMUNICATION LINE <a href="#">AT-94</a> . <input type="checkbox"/> DTC P0615 START SIGNAL CIRCUIT <a href="#">AT-97</a> . <input type="checkbox"/> DTC P0700 TCM <a href="#">AT-101</a> <input type="checkbox"/> DTC P0705 PARK/NEUTRAL POSITION SWITCH <a href="#">AT-102</a> . <input type="checkbox"/> DTC P0717 TURBINE REVOLUTION SENSOR <a href="#">AT-106</a> . <input type="checkbox"/> DTC P0720 VEHICLE SPEED SENSOR A/T (REVOLUTION SENSOR) <a href="#">AT-108</a> . <input type="checkbox"/> DTC P0725 ENGINE SPEED SIGNAL <a href="#">AT-112</a> . <input type="checkbox"/> DTC P0731 A/T 1ST GEAR FUNCTION <a href="#">AT-114</a> . <input type="checkbox"/> DTC P0732 A/T 2ND GEAR FUNCTION <a href="#">AT-116</a> . <input type="checkbox"/> DTC P0733 A/T 3RD GEAR FUNCTION <a href="#">AT-118</a> . <input type="checkbox"/> DTC P0734 A/T 4TH GEAR FUNCTION <a href="#">AT-120</a> . <input type="checkbox"/> DTC P0735 A/T 5TH GEAR FUNCTION <a href="#">AT-122</a> . <input type="checkbox"/> DTC P0740 TORQUE CONVERTER CLUTCH SOLENOID VALVE <a href="#">AT-124</a> . <input type="checkbox"/> DTC P0744 A/T TCC S/V FUNCTION (LOCK-UP) <a href="#">AT-126</a> . <input type="checkbox"/> DTC P0745 LINE PRESSURE SOLENOID VALVE <a href="#">AT-128</a> . <input type="checkbox"/> DTC P1705 THROTTLE POSITION SENSOR <a href="#">AT-130</a> . <input type="checkbox"/> DTC P1710 A/T FLUID TEMPERATURE SENSOR CIRCUIT <a href="#">AT-132</a> . <input type="checkbox"/> DTC P1721 VEHICLE SPEED SENSOR MTR <a href="#">AT-137</a> . <input type="checkbox"/> DTC P1730 A/T INTERLOCK <a href="#">AT-139</a> . <input type="checkbox"/> DTC P1731 A/T 1ST ENGINE BRAKING <a href="#">AT-141</a> . <input type="checkbox"/> DTC P1752 INPUT CLUTCH SOLENOID VALVE <a href="#">AT-143</a> . <input type="checkbox"/> DTC P1757 FRONT BRAKE SOLENOID VALVE <a href="#">AT-145</a> . <input type="checkbox"/> DTC P1762 DIRECT CLUTCH SOLENOID VALVE <a href="#">AT-147</a> . <input type="checkbox"/> DTC P1767 HIGH AND LOW REVERSE CLUTCH SOLENOID VALVE <a href="#">AT-149</a> . <input type="checkbox"/> DTC P1772 LOW COAST BRAKE SOLENOID VALVE <a href="#">AT-151</a> . <input type="checkbox"/> DTC P1774 LOW COAST BRAKE SOLENOID VALVE FUNCTION <a href="#">AT-153</a> . <input type="checkbox"/> DTC P1815 MANUAL MODE SWITCH <a href="#">AT-155</a> .	
4	4-2. Check at Idle	<a href="#">AT-53</a>
	<input type="checkbox"/> <a href="#">AT-170</a> . "Engine Cannot Be Started in "P" or "N" Position". <input type="checkbox"/> <a href="#">AT-171</a> . "In "P" Position, Vehicle Moves When Pushed" <input type="checkbox"/> <a href="#">AT-172</a> . "In "N" Position, Vehicle Moves". <input type="checkbox"/> <a href="#">AT-173</a> . "Large Shock ("N" to "D" Position)". <input type="checkbox"/> <a href="#">AT-175</a> . "Vehicle Does Not Creep Backward in "R" Position". <input type="checkbox"/> <a href="#">AT-178</a> . "Vehicle Does Not Creep Forward in "D" Position".	
4	4-3. Cruise Test	<a href="#">AT-53</a>
	Part 1 <input type="checkbox"/> <a href="#">AT-180</a> . "Vehicle Cannot Be Started from D1". <input type="checkbox"/> <a href="#">AT-182</a> . "A/T Does Not Shift: D1→ D2". <input type="checkbox"/> <a href="#">AT-184</a> . "A/T Does Not Shift: D2→ D3". <input type="checkbox"/> <a href="#">AT-186</a> . "A/T Does Not Shift: D3→ D4". <input type="checkbox"/> <a href="#">AT-188</a> . "A/T Does Not Shift: D4→ D5". <input type="checkbox"/> <a href="#">AT-190</a> . "A/T Does Not Lock-up" <input type="checkbox"/> <a href="#">AT-192</a> . "A/T Does Not Hold Lock-up Condition". <input type="checkbox"/> <a href="#">AT-194</a> . "Lock-up Is Not Released". <input type="checkbox"/> <a href="#">AT-194</a> . "Engine Speed Does Not Return to Idle".	

# TROUBLE DIAGNOSIS

## < SERVICE INFORMATION >

4	4-3.	Part 2	<a href="#">AT-53</a>	A
		<input type="checkbox"/> <a href="#">AT-180, "Vehicle Cannot Be Started from D1".</a> <input type="checkbox"/> <a href="#">AT-182, "A/T Does Not Shift: D1→ D2".</a> <input type="checkbox"/> <a href="#">AT-184, "A/T Does Not Shift: D2→ D3".</a> <input type="checkbox"/> <a href="#">AT-186, "A/T Does Not Shift: D3→ D4".</a>		B
		Part 3	<a href="#">AT-53</a>	AT
		<input type="checkbox"/> <a href="#">AT-195, "Cannot Be Changed to Manual Mode".</a> <input type="checkbox"/> <a href="#">AT-196, "A/T Does Not Shift: 5th Gear → 4th Gear".</a> <input type="checkbox"/> <a href="#">AT-197, "A/T Does Not Shift: 4th Gear → 3rd Gear".</a> <input type="checkbox"/> <a href="#">AT-199, "A/T Does Not Shift: 3rd Gear → 2nd Gear".</a> <input type="checkbox"/> <a href="#">AT-201, "A/T Does Not Shift: 2nd Gear → 1st Gear".</a> <input type="checkbox"/> <a href="#">AT-202, "Vehicle Does Not Decelerate by Engine Brake".</a> <input type="checkbox"/> Perform self-diagnostics. Enter checks for detected items. <a href="#">AT-84</a> , <a href="#">AT-91</a> .		D
		<input type="checkbox"/> DTC U1000 CAN COMMUNICATION LINE <a href="#">AT-94</a> . <input type="checkbox"/> DTC P0615 START SIGNAL CIRCUIT <a href="#">AT-97</a> . <input type="checkbox"/> DTC P0700 TCM <a href="#">AT-101</a> <input type="checkbox"/> DTC P0705 PARK/NEUTRAL POSITION SWITCH <a href="#">AT-102</a> . <input type="checkbox"/> DTC P0717 TURBINE REVOLUTION SENSOR <a href="#">AT-106</a> . <input type="checkbox"/> DTC P0720 VEHICLE SPEED SENSOR A/T (REVOLUTION SENSOR) <a href="#">AT-108</a> . <input type="checkbox"/> DTC P0725 ENGINE SPEED SIGNAL <a href="#">AT-112</a> . <input type="checkbox"/> DTC P0731 A/T 1ST GEAR FUNCTION <a href="#">AT-114</a> . <input type="checkbox"/> DTC P0732 A/T 2ND GEAR FUNCTION <a href="#">AT-116</a> . <input type="checkbox"/> DTC P0733 A/T 3RD GEAR FUNCTION <a href="#">AT-118</a> . <input type="checkbox"/> DTC P0734 A/T 4TH GEAR FUNCTION <a href="#">AT-120</a> . <input type="checkbox"/> DTC P0735 A/T 5TH GEAR FUNCTION <a href="#">AT-122</a> . <input type="checkbox"/> DTC P0740 TORQUE CONVERTER CLUTCH SOLENOID VALVE <a href="#">AT-124</a> . <input type="checkbox"/> DTC P0744 A/T TCC S/V FUNCTION (LOCK-UP) <a href="#">AT-126</a> . <input type="checkbox"/> DTC P0745 LINE PRESSURE SOLENOID VALVE <a href="#">AT-128</a> . <input type="checkbox"/> DTC P1705 THROTTLE POSITION SENSOR <a href="#">AT-130</a> . <input type="checkbox"/> DTC P1710 A/T FLUID TEMPERATURE SENSOR CIRCUIT <a href="#">AT-132</a> . <input type="checkbox"/> DTC P1721 VEHICLE SPEED SENSOR MTR <a href="#">AT-137</a> . <input type="checkbox"/> DTC P1730 A/T INTERLOCK <a href="#">AT-139</a> . <input type="checkbox"/> DTC P1731 A/T 1ST ENGINE BRAKING <a href="#">AT-141</a> . <input type="checkbox"/> DTC P1752 INPUT CLUTCH SOLENOID VALVE <a href="#">AT-143</a> . <input type="checkbox"/> DTC P1757 FRONT BRAKE SOLENOID VALVE <a href="#">AT-145</a> . <input type="checkbox"/> DTC P1762 DIRECT CLUTCH SOLENOID VALVE <a href="#">AT-147</a> . <input type="checkbox"/> DTC P1767 HIGH AND LOW REVERSE CLUTCH SOLENOID VALVE <a href="#">AT-149</a> . <input type="checkbox"/> DTC P1772 LOW COAST BRAKE SOLENOID VALVE <a href="#">AT-151</a> . <input type="checkbox"/> DTC P1774 LOW COAST BRAKE SOLENOID VALVE FUNCTION <a href="#">AT-153</a> . <input type="checkbox"/> DTC P1815 MANUAL MODE SWITCH <a href="#">AT-155</a> .		E
5		<input type="checkbox"/> Inspect each system for items found to be NG in the self-diagnostics and repair or replace the malfunctioning parts.		F
6		<input type="checkbox"/> Perform all road tests and enter the checks again for the required items.	<a href="#">AT-49</a>	G
7		<input type="checkbox"/> For any remaining NG items, perform the "diagnostics procedure" and repair or replace the malfunctioning parts. See the chart for diagnostics by symptoms. (This chart also contains other symptoms and inspection procedures.)	<a href="#">AT-59</a>	H
8		<input type="checkbox"/> Erase the results of the self-diagnostics from the TCM and the ECM.	<a href="#">AT-84</a> , <a href="#">AT-91</a>	I
				J
				K
				L
				M
				N
				O
				P

# TROUBLE DIAGNOSIS

< SERVICE INFORMATION >

## A/T Electrical Parts Location

INFOID:000000001327151

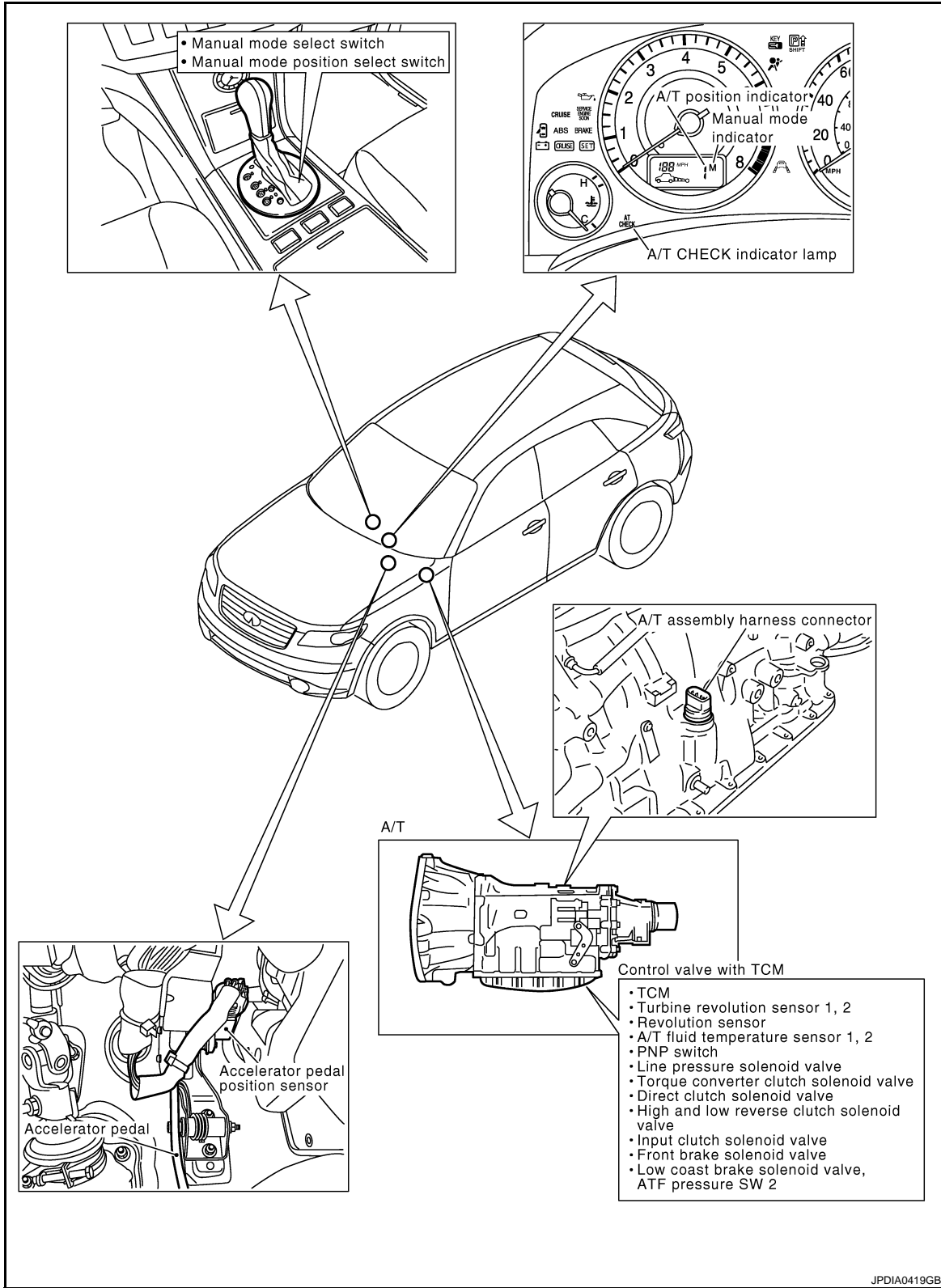



# TROUBLE DIAGNOSIS

< SERVICE INFORMATION >

## Circuit Diagram

INFOID:000000001327152

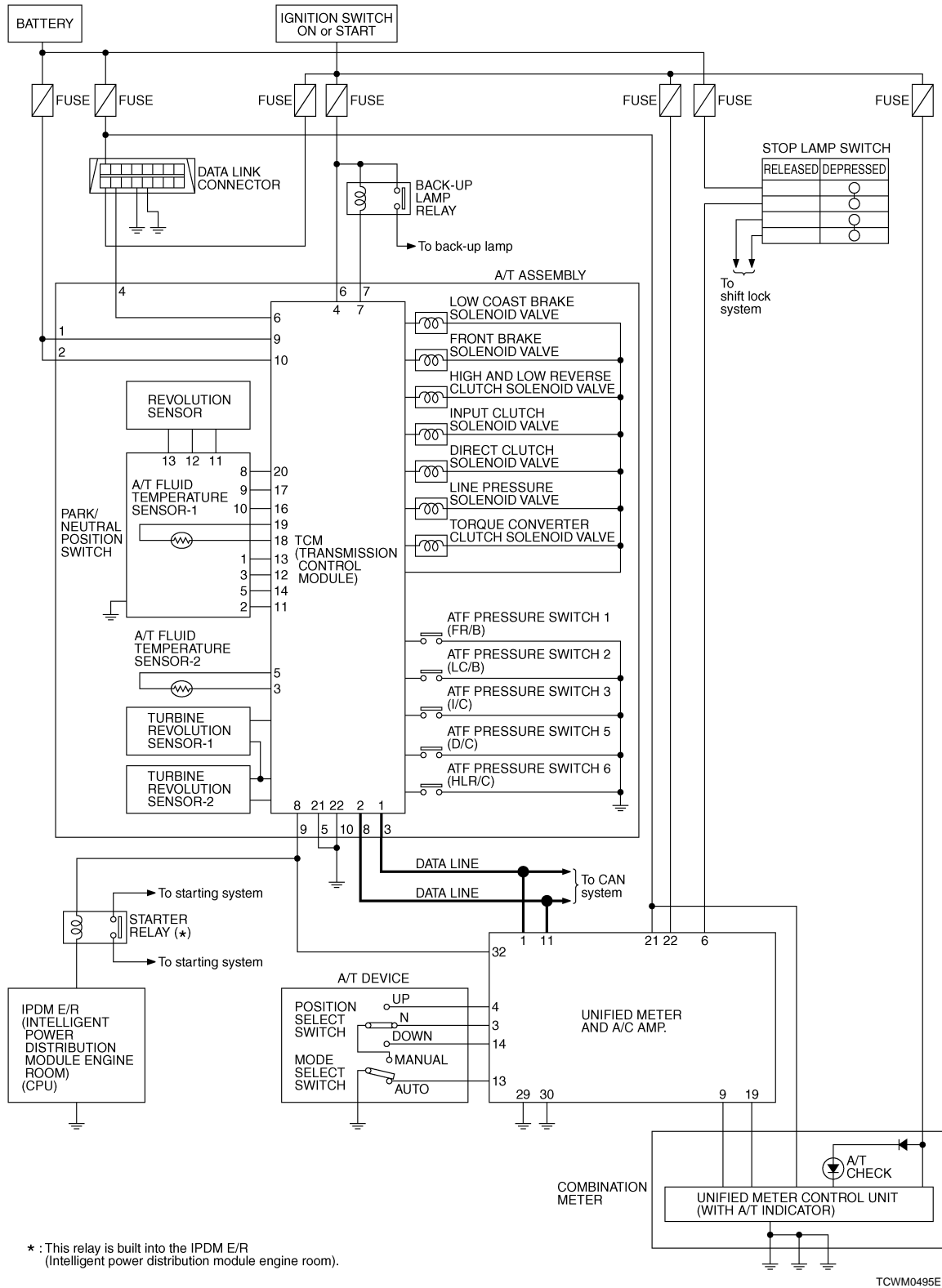

A  
B  
AT  
D  
E  
F  
G  
H  
I  
J  
K  
L  
M  
N  
O  
P

## Inspections Before Trouble Diagnosis

INFOID:000000001327153

### A/T FLUID CHECK

A/T Fluid Leakage and A/T Fluid Level Check

Check for A/T fluid leakage and check the A/T fluid level. Refer to [AT-11. "Checking A/T Fluid"](#).

# TROUBLE DIAGNOSIS

## < SERVICE INFORMATION >

A/T Fluid Condition Check  
Inspect the A/T fluid condition.

Fluid condition	Conceivable Cause	Required Operation
Varnished (viscous varnish state)	Clutch, brake scorched	Replace the ATF and check the A/T main unit and the vehicle for malfunctions (wire harnesses, cooler pipes, etc.)
Milky white or cloudy	Water in the fluid	Replace the ATF and check for places where water is getting in.
Large amount of metal powder mixed in	Unusual wear of sliding parts within A/T	Replace the ATF and check for improper operation of the A/T.

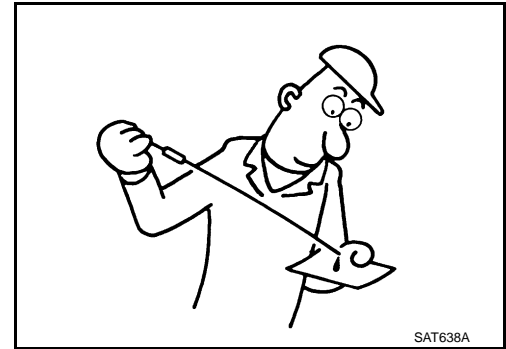

SAT638A

## STALL TEST

### Stall Test Procedure

1. Inspect the amount of engine oil. Replenish the engine oil if necessary.
2. Drive for about 10 minutes to warm up the vehicle so that the A/T fluid temperature is 50 to 80°C (122 to 176°F). Check the amount of ATF. Replenish if necessary.

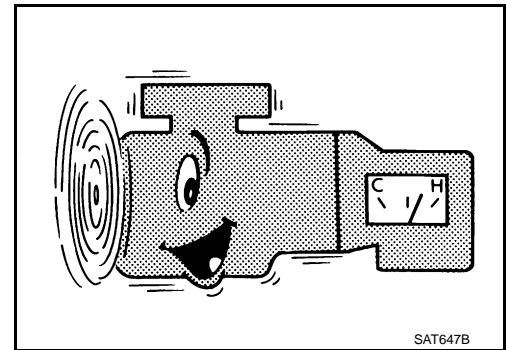

SAT647B

3. Securely engage the parking brake so that the tires do not turn.
4. Start engine, apply foot brake, and place selector lever in "D" position.

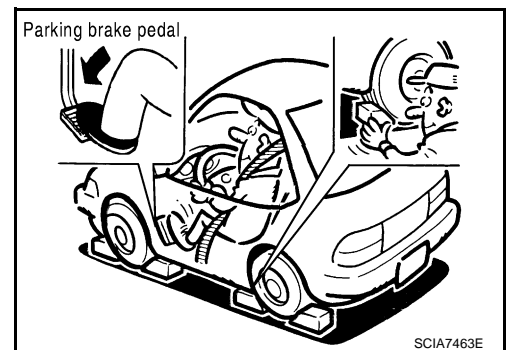

SCIA7463E

5. While holding down the foot brake, gradually press down the accelerator pedal.
6. Quickly read off the stall speed, then quickly remove your foot from the accelerator pedal.

### CAUTION:

**Do not hold down the accelerator pedal for more than 5 seconds during this test.**

### Stall speed

**VQ35DE engine: 2,650 - 2,950 rpm**

**VK45DE engine: 2,260 - 2,560 rpm**

7. Move the selector lever to the "N" position.
8. Cool down the ATF.

### CAUTION:

**Run the engine at idle for at least 1 minute.**

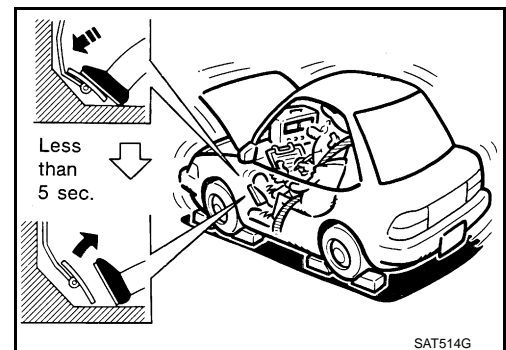

SAT514G

# TROUBLE DIAGNOSIS

## < SERVICE INFORMATION >

9. Repeat steps 5 through 8 with selector lever in "R" position.

### Judgement of Stall Test

	Selector lever position		Expected problem location
	"D", "M"	"R"	
Stall speed	H	O	<ul style="list-style-type: none"> <li>• Forward brake</li> <li>• Forward one-way clutch</li> <li>• 1st one-way clutch</li> <li>• 3rd one-way clutch</li> </ul>
	O	H	<ul style="list-style-type: none"> <li>• Reverse brake</li> </ul>
	L	L	<ul style="list-style-type: none"> <li>• Engine and torque converter one-way clutch</li> </ul>
	H	H	<ul style="list-style-type: none"> <li>• Line pressure low</li> </ul>

O: Stall speed within standard value position

H: Stall speed higher than standard value

L: Stall speed lower than standard value

### Stall test standard value position

Does not shift-up "D" or "M" position 1 → 2	Slipping in 2nd, 3rd or 4th gear	Direct clutch slippage
Does not shift-up "D" or "M" position 2 → 3	Slipping in 3rd, 4th or 5th gear	High and low reverse clutch slippage
Does not shift-up "D" or "M" position 3 → 4	Slipping in 4th or 5th gear	Input clutch slippage
Does not shift-up "D" or "M" position 4 → 5	Slipping in 5th gear	Front brake slippage

## LINE PRESSURE TEST

### Line Pressure Test Port

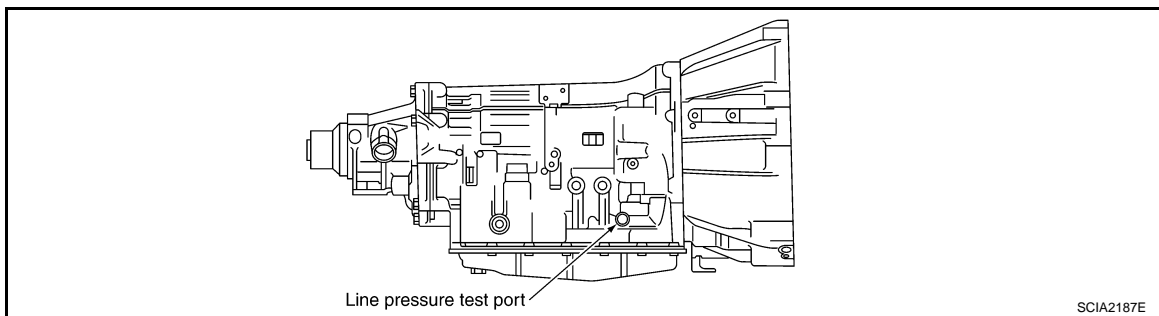

### Line Pressure Test Procedure

1. Inspect the amount of engine oil and replenish if necessary.
2. Drive the car for about 10 minutes to warm it up so that the ATF reaches in range of 50 to 80°C (122 to 176°F), then inspect the amount of ATF and replenish if necessary.

#### NOTE:

**The A/T fluid temperature rises in range of 50 to 80°C (122 to 176°F) during 10 minutes of driving.**

3. Remove the front propeller shaft from vehicle (with AWD models). Refer to [PR-4, "Removal and Installation"](#).

4. After warming up remove the oil pressure detection plug and install the oil pressure gauge [ST2505S001(J-34301-C)].

#### CAUTION:

**When using the oil pressure gauge, be sure to use the O-ring attached to the oil pressure detection plug.**

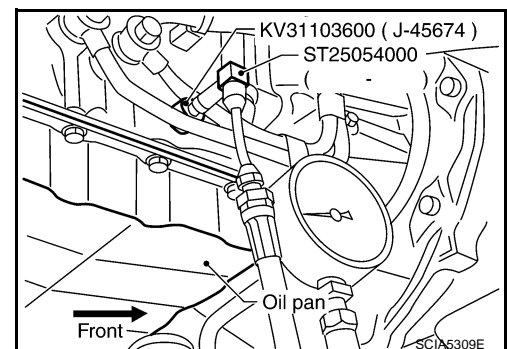

# TROUBLE DIAGNOSIS

## < SERVICE INFORMATION >

5. Securely engage the parking brake so that the tires do not turn.

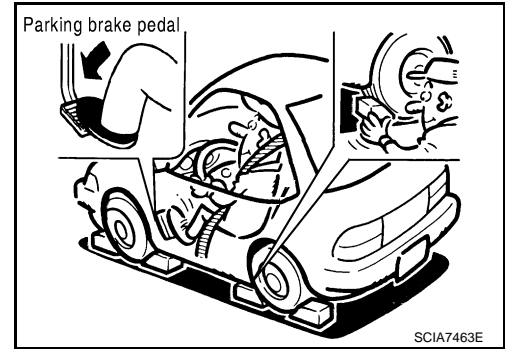

6. Start the engine, then measure the line pressure at both idle and the stall speed.

**CAUTION:**

- Keep the brake pedal pressed all the way down during measurement.
- When measuring the line pressure at the stall speed, refer to "STALL TEST".

7. After the measurements are complete, install the oil pressure detection plug and tighten to the specified torque.

**7.3 N·m (0.74 kg·m, 65 in·lb)**

**CAUTION:**

- Do not reuse the O-ring.
- Apply ATF to the O-ring.

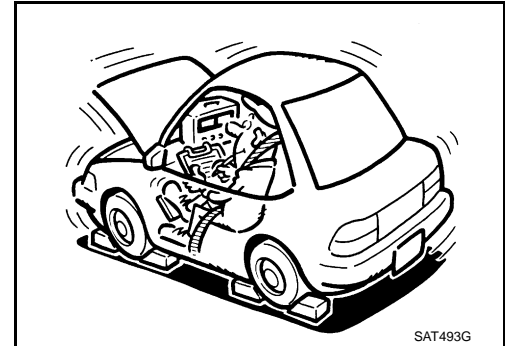

### Line Pressure

Engine speed	Line pressure kPa (kg/cm <sup>2</sup> , psi)	
	"R" position	"D" and "M" positions
At idle speed	425 - 465 (4.3 - 4.7, 62 - 67)	379 - 428 (3.9 - 4.4, 55 - 62)
At stall speed	1,605 - 1,950 (16.4 - 19.9, 233 - 283)	1,310 - 1,500 (13.4 - 15.3, 190 - 218)

### Judgement of Line Pressure Test

Judgement		Possible cause
Idle speed	Low for all positions ("P", "R", "N", "D", "M")	Possible causes include malfunctions in the pressure supply system and low oil pump output. For example <ul style="list-style-type: none"> <li>• Oil pump wear</li> <li>• Pressure regulator valve or plug sticking or spring fatigue</li> <li>• Oil strainer ⇒ oil pump ⇒ pressure regulator valve passage oil leak</li> <li>• Engine idle speed too low</li> </ul>
	Only low for a specific position	Possible causes include an oil pressure leak in a passage or device related to the position after the pressure is distributed by the manual valve.
	High	Possible causes include a sensor malfunction or malfunction in the line pressure adjustment function. For example <ul style="list-style-type: none"> <li>• Accelerator pedal position signal malfunction</li> <li>• ATF temperature sensor malfunction</li> <li>• Line pressure solenoid malfunction (sticking in OFF state, filter clog, cut line)</li> <li>• Pressure regulator valve or plug sticking</li> </ul>

# TROUBLE DIAGNOSIS

## < SERVICE INFORMATION >

Judgement		Possible cause	
Stall speed	Line pressure does not rise higher than the line pressure for idle.	Possible causes include a sensor malfunction or malfunction in the pressure adjustment function. For example <ul style="list-style-type: none"> <li>• Accelerator pedal position signal malfunction</li> <li>• TCM breakdown</li> <li>• Line pressure solenoid malfunction (shorting, sticking in ON state)</li> <li>• Pressure regulator valve or plug sticking</li> <li>• Pilot valve sticking or pilot filter clogged</li> </ul>	A B
	The pressure rises, but does not enter the standard position.	Possible causes include malfunctions in the pressure supply system and malfunction in the pressure adjustment function. For example <ul style="list-style-type: none"> <li>• Accelerator pedal position signal malfunction</li> <li>• Line pressure solenoid malfunction (sticking, filter clog)</li> <li>• Pressure regulator valve or plug sticking</li> <li>• Pilot valve sticking or pilot filter clogged</li> </ul>	AT D
	Only low for a specific position	Possible causes include an oil pressure leak in a passage or device related to the position after the pressure is distributed by the manual valve.	E

## Road Test

INFOID:000000001425855

### DESCRIPTION

- The road test checks overall performance of the A/T and analyzes possible malfunction causes.
- The road test is carried out in the following three stages.
  1. Check before engine is started.
  2. Check at idle.
  3. Cruise test
    - Inspect all the items Part 1 to Part 3.
- Before beginning the road test, check the procedure and inspection items.
- Test all inspection items until the symptom is uncovered. Diagnose NG items when all road tests are complete.

### CHECK BEFORE ENGINE IS STARTED

#### 1. CHECK A/T CHECK INDICATOR LAMP

1. Park vehicle on level surface.
2. Move selector lever to "P" position.
3. Turn ignition switch OFF and wait at least 10 seconds.
4. Turn ignition switch ON.

Does A/T CHECK indicator lamp light up for about 2 seconds?

YES - 1>>  **With CONSULT-III**

1. Perform self-diagnostics and record all NG items on the "Diagnostic Worksheet Chart".
2. Go to "CHECK AT IDLE".

YES - 2>>  **Without CONSULT-III**

1. Perform self-diagnostics and record all NG items on the "Diagnostic Worksheet Chart". Refer to [AT-91, "Diagnosis Procedure without CONSULT-III"](#).
2. Go to "CHECK AT IDLE".

NO >> Stop the road test and go to [AT-170, "A/T Check Indicator Lamp Does Not Come On"](#).

### CHECK AT IDLE

#### 1. CHECK STARTING THE ENGINE

1. Park vehicle on level surface.
2. Move selector lever to "P" or "N" position.
3. Turn ignition switch OFF.
4. Start engine.

Does the engine start?

YES >> GO TO 2.

NO >> Stop the road test and go to [AT-170, "Engine Cannot Be Started in "P" or "N" Position"](#).

# TROUBLE DIAGNOSIS

## < SERVICE INFORMATION >

---

### 2. CHECK STARTING THE ENGINE

---

1. Turn ignition switch ON. (Do not start engine.)
2. Move selector lever to "D", "M" or "R" position.
3. Start engine.

#### Does the engine start in either position?

- YES >> Stop the road test and go to [AT-170, "Engine Cannot Be Started in "P" or "N" Position"](#).
- NO >> GO TO 3.

### 3. CHECK "P" POSITION FUNCTIONS

---

1. Move selector lever to "P" position.
2. Turn ignition switch OFF.
3. Disengage the parking brake.
4. Push the vehicle forward or backward.
5. Engage the parking brake.

#### When you push the vehicle with disengaging the parking brake, does it move?

- YES >> Enter a check mark at [AT-171, "In "P" Position, Vehicle Moves When Pushed"](#) on the "Diagnostic Worksheet Chart", then continue the road test.
- NO >> GO TO 4.

### 4. CHECK "N" POSITION FUNCTIONS

---

1. Start engine.
2. Move selector lever to "N" position.
3. Disengage the parking brake.

#### Does vehicle move forward or backward?

- YES >> Enter a check mark at [AT-172, "In "N" Position, Vehicle Moves"](#) on the "Diagnostic Worksheet Chart", then continue the road test.
- NO >> GO TO 5.

### 5. CHECK SHIFT SHOCK

---

1. Engage the brake.
2. Move selector lever to "D" position.

#### When the transmission is shifted from "N" to "D", is there an excessive shock?

- YES >> Enter a check mark at [AT-173, "Large Shock \("N" to "D" Position\)"](#) on the "Diagnostic Worksheet Chart", then continue the road test.
- NO >> GO TO 6.

### 6. CHECK "R" POSITION FUNCTIONS

---

1. Engage the brake.
2. Move selector lever to "R" position.
3. Disengage the brake for 4 to 5 seconds.

#### Does the vehicle creep backward?

- YES >> GO TO 7.
- NO >> Enter a check mark at [AT-175, "Vehicle Does Not Creep Backward in "R" Position"](#) on the "Diagnostic Worksheet Chart", then continue the road test.

### 7. CHECK "D" POSITION FUNCTIONS

---

Inspect whether the vehicle creep forward when the A/T is put into the "D" position.

#### Does the vehicle creep forward in the "D" position?

- YES >> Go to [AT-53, "Road Test"](#).
- NO >> Enter a check mark at [AT-178, "Vehicle Does Not Creep Forward in "D" Position"](#) on the "Diagnostic Worksheet Chart", then continue the road test.

## CRUISE TEST - PART 1

### 1. CHECK STARTING OUT FROM D<sub>1</sub>

---

1. Drive the vehicle for about 10 minutes to warm up the engine oil and ATF.  
Appropriate temperature for the ATF: 50 to 80°C (122 to 176°F)

# TROUBLE DIAGNOSIS

## < SERVICE INFORMATION >

2. Park the vehicle on a level surface.
3. Move selector lever to "P" position.
4. Start the engine.
5. Move selector lever to "D" position.
6. Press the accelerator pedal about half-way down to accelerate the vehicle.

### With CONSULT-III

Read the gear positions. Refer to [AT-84, "CONSULT-III Function \(TRANSMISSION\)"](#).

#### Starts from D1?

YES >> GO TO 2.

NO >> Enter a check mark at [AT-180, "Vehicle Cannot Be Started from D1"](#) on the "Diagnostic Worksheet Chart", then continue the road test.

## 2. CHECK SHIFT-UP D1 → D2

Press down the accelerator pedal about half-way and inspect if the vehicle shifts up (D1 → D2) at the appropriate speed. Refer to [AT-58, "Vehicle Speed at Which Gear Shifting Occurs"](#).

### With CONSULT-III

Read the gear position, throttle degree of opening, and vehicle speed. Refer to [AT-84, "CONSULT-III Function \(TRANSMISSION\)"](#).

#### Does the A/T shift-up D1 → D2 at the correct speed?

YES >> GO TO 3.

NO >> Enter a check mark at [AT-182, "A/T Does Not Shift: D1→D2"](#) on the "Diagnostic Worksheet Chart", then continue the road test.

## 3. CHECK SHIFT-UP D2 → D3

Press down the accelerator pedal about half-way and inspect if the vehicle shifts up (D2 → D3) at the appropriate speed. Refer to [AT-58, "Vehicle Speed at Which Gear Shifting Occurs"](#).

### With CONSULT-III

Read the gear position, throttle degree of opening, and vehicle speed. Refer to [AT-84, "CONSULT-III Function \(TRANSMISSION\)"](#).

#### Does the A/T shift-up D2 → D3 at the correct speed?

YES >> GO TO 4.

NO >> Enter a check mark at [AT-184, "A/T Does Not Shift: D2→D3"](#) on the "Diagnostic Worksheet Chart", then continue the road test.

## 4. CHECK SHIFT-UP D3 → D4

Press down the accelerator pedal about half-way and inspect if the vehicle shifts up (D3 → D4) at the appropriate speed. Refer to [AT-58, "Vehicle Speed at Which Gear Shifting Occurs"](#).

### With CONSULT-III

Read the gear position, throttle degree of opening, and vehicle speed. Refer to [AT-84, "CONSULT-III Function \(TRANSMISSION\)"](#).

#### Does the A/T shift-up D3 → D4 at the correct speed?

YES >> GO TO 5.

NO >> Enter a check mark at [AT-186, "A/T Does Not Shift: D3→D4"](#) on the "Diagnostic Worksheet Chart", then continue the road test.

## 5. CHECK SHIFT-UP D4 → D5

Press down the accelerator pedal about half-way and inspect if the vehicle shifts up (D4 → D5) at the appropriate speed. Refer to [AT-58, "Vehicle Speed at Which Gear Shifting Occurs"](#).

### With CONSULT-III

Read the gear position, throttle degree of opening, and vehicle speed. Refer to [AT-84, "CONSULT-III Function \(TRANSMISSION\)"](#).

#### Does the A/T shift-up D4 → D5 at the correct speed?

YES >> GO TO 6.

NO >> Enter a check mark at [AT-188, "A/T Does Not Shift: D4→D5"](#) on the "Diagnostic Worksheet Chart", then continue the road test.

## 6. CHECK LOCK-UP



# TROUBLE DIAGNOSIS

## < SERVICE INFORMATION >

When releasing accelerator pedal from D5, check lock-up from D5 to L/U. Refer to [AT-58, "Vehicle Speed at Which Lock-up Occurs/Releases"](#).

### With CONSULT-III

Select "TCC SOLENOID" with the "DATA MONITOR" mode for "TRANSMISSION". Refer to [AT-84, "CONSULT-III Function \(TRANSMISSION\)"](#).

Does it lock-up?

YES >> GO TO 7.

NO >> Enter a check mark at [AT-190, "A/T Does Not Lock-up"](#) on the "Diagnostic Worksheet Chart", then continue the road test.

## 7.CHECK LOCK-UP HOLD

Check hold lock-up.

### With CONSULT-III

Select "TCC SOLENOID" with the "DATA MONITOR" mode for "TRANSMISSION". Refer to [AT-84, "CONSULT-III Function \(TRANSMISSION\)"](#).

Does it maintain lock-up status?

YES >> GO TO 8.

NO >> Enter a check mark at [AT-192, "A/T Does Not Hold Lock-up Condition"](#) on the "Diagnostic Worksheet Chart", then continue the road test.

## 8.CHECK LOCK-UP RELEASE

Check lock-up cancellation by depressing brake pedal lightly to decelerate.

### With CONSULT-III

Select "TCC SOLENOID" with the "DATA MONITOR" mode for "TRANSMISSION". Refer to [AT-84, "CONSULT-III Function \(TRANSMISSION\)"](#).

Does lock-up cancel?

YES >> GO TO 9.

NO >> Enter a check mark at [AT-194, "Lock-up Is Not Released"](#) on the "Diagnostic Worksheet Chart", then continue the road test.

## 9.CHECK SHIFT-DOWN D5 → D4

Decelerate by pressing lightly on the brake pedal.

### With CONSULT-III

Read the gear position and engine speed. Refer to [AT-84, "CONSULT-III Function \(TRANSMISSION\)"](#).

When the A/T shift-down D5 → D4, does the engine speed drop smoothly back to idle?

YES >> 1. Stop the vehicle.  
2. Go to [AT-53, "Road Test"](#).

NO >> Enter a check mark at [AT-194, "Engine Speed Does Not Return to Idle"](#) on the "Diagnostic Worksheet Chart", then continue the road test. Go to [AT-53, "Road Test"](#).

## CRUISE TEST - PART 2

### 1.CHECK STARTING FROM D1

1. Move selector lever into "D" position.
2. Accelerate at half throttle.

### With CONSULT-III

Read the gear position. Refer to [AT-84, "CONSULT-III Function \(TRANSMISSION\)"](#).

Does it start from D1?

YES >> GO TO 2.

NO >> Enter a check mark at [AT-180, "Vehicle Cannot Be Started from D1"](#) on the "Diagnostic Worksheet Chart", then continue the road test.

### 2.CHECK SHIFT-UP D1 → D2

Press the accelerator pedal down all the way and check whether or not the A/T shifts up (D1 → D2) at the correct speed. Refer to [AT-58, "Vehicle Speed at Which Gear Shifting Occurs"](#).

### With CONSULT-III



# TROUBLE DIAGNOSIS

## < SERVICE INFORMATION >

Read the gear position, throttle position and vehicle speed. Refer to [AT-84, "CONSULT-III Function \(TRANSMISSION\)"](#).

Does the A/T shift-up D1 → D2 at the correct speed?

YES >> GO TO 3.

NO >> Enter a check mark at [AT-182, "A/T Does Not Shift: D1→D2"](#) on the "Diagnostic Worksheet Chart", then continue the road test.

### 3.CHECK SHIFT-UP D2 → D3

Press the accelerator pedal down all the way and check whether or not the A/T shifts up (D2 → D3) at the correct speed. Refer to [AT-58, "Vehicle Speed at Which Gear Shifting Occurs"](#).

**With CONSULT-III**

Read the gear position, throttle position and vehicle speed. Refer to [AT-84, "CONSULT-III Function \(TRANSMISSION\)"](#).

Does the A/T shift-up D2 → D3 at the correct speed?

YES >> GO TO 4.

NO >> Enter a check mark at [AT-184, "A/T Does Not Shift: D2→D3"](#) on the "Diagnostic Worksheet Chart", then continue the road test.

### 4.CHECK SHIFT-UP D3 → D4 AND ENGINE BRAKE

When the A/T changes speed D3 → D4, return the accelerator pedal.

**With CONSULT-III**

Read the gear position. Refer to [AT-84, "CONSULT-III Function \(TRANSMISSION\)"](#).

Does the A/T shift-up D3 → D4 and apply the engine brake?

YES >> 1. Stop the vehicle.

2. Go to [AT-53, "Road Test"](#).

NO >> Enter a check mark at [AT-186, "A/T Does Not Shift: D3→D4"](#) on the "Diagnostic Worksheet Chart", then continue the road test. Go to [AT-53, "Road Test"](#).

## CRUISE TEST - PART 3

### 1.MANUAL MODE FUNCTION

Move to manual mode from "D" position.

Does it switch to manual mode?

YES >> GO TO 2.

NO >> Continue road test and add check mark to [AT-195, "Cannot Be Changed to Manual Mode"](#) on the "Diagnostic Worksheet Chart".

### 2.CHECK SHIFT-DOWN

During manual mode driving, is downshift from M5 → M4 → M3 → M2 → M1 performed?

**With CONSULT-III**

Read the gear position. Refer to [AT-84, "CONSULT-III Function \(TRANSMISSION\)"](#).

Is downshifting correctly performed?

YES >> GO TO 3.

NO >> Enter a check mark at "Vehicle Does Not Shift" at the corresponding position (5th → 4th, 4th → 3rd, 3rd → 2nd, 2nd → 1st) on the "Diagnostic Worksheet Chart", then continue the road test.

### 3.CHECK ENGINE BRAKE

Check engine brake.

Does engine braking effectively reduce speed in M1 position?

YES - 1>>  **With CONSULT-III**

1. Stop the vehicle.

2. Perform self-diagnostics.

YES - 2>>  **Without CONSULT-III**

1. Stop the vehicle.

2. Perform self-diagnostics. Refer to [AT-91, "Diagnosis Procedure without CONSULT-III"](#).

NO >> Enter a check mark at [AT-202, "Vehicle Does Not Decelerate by Engine Brake"](#) on the "Diagnostic Worksheet Chart", then continue trouble diagnosis.

# TROUBLE DIAGNOSIS

< SERVICE INFORMATION >

## Vehicle Speed at Which Gear Shifting Occurs

INFOID:000000001327159

### 2WD MODELS

Engine model	VQ35DE							
Throttle position	Vehicle speed km/h (MPH)							
	D1→D2	D2→D3	D3→D4	D4→D5	D5→D4	D4→D3	D3→D2	D2→D1
Full throttle	68 - 72 (42 - 45)	106 - 114 (66 - 71)	164 - 174 (102 - 108)	235 - 245 (146 - 152)	231 - 241 (144 - 150)	144 - 154 (89 - 96)	89 - 97 (55 - 60)	43 - 47 (27 - 29)
Half throttle	54 - 58 (34 - 36)	84 - 90 (52 - 56)	127 - 135 (79 - 84)	159 - 167 (99 - 104)	104 - 112 (65 - 70)	75 - 83 (47 - 52)	35 - 41 (22 - 25)	11 - 15 (7 - 9)

- At half throttle, the accelerator opening is 4/8 of the full opening.

### AWD MODELS

Engine model	VQ35DE							
Throttle position	Vehicle speed km/h (MPH)							
	D1→D2	D2→D3	D3→D4	D4→D5	D5→D4	D4→D3	D3→D2	D2→D1
Full throttle	62 - 66 (39 - 41)	96 - 104 (60 - 65)	149 - 159 (93 - 99)	213 - 223 (132 - 139)	209 - 219 (130 - 136)	131 - 141 (81 - 88)	81 - 89 (50 - 55)	39 - 43 (24 - 27)
Half throttle	49 - 53 (30 - 33)	76 - 82 (47 - 51)	115 - 123 (71 - 76)	144 - 152 (89 - 94)	95 - 103 (59 - 64)	67 - 75 (42 - 47)	32 - 38 (20 - 24)	11 - 15 (7 - 9)

- At half throttle, the accelerator opening is 4/8 of the full opening.

Engine model	VK45DE							
Throttle position	Vehicle speed km/h (MPH)							
	D1→D2	D2→D3	D3→D4	D4→D5	D5→D4	D4→D3	D3→D2	D2→D1
Full throttle	59 - 63 (37 - 39)	95 - 103 (59 - 64)	147 - 157 (92 - 98)	219 - 229 (137 - 143)	215 - 225 (134 - 141)	130 - 140 (81 - 88)	82 - 90 (51 - 56)	35 - 39 (22 - 24)
Half throttle	48 - 52 (30 - 33)	78 - 84 (48 - 52)	122 - 130 (76 - 81)	154 - 162 (96 - 101)	122 - 130 (76 - 81)	68 - 76 (42 - 47)	40 - 46 (25 - 29)	9 - 13 (6 - 8)

- At half throttle, the accelerator opening is 4/8 of the full opening.

## Vehicle Speed at Which Lock-up Occurs/Releases

INFOID:000000001327160

### 2WD MODELS

Engine model	VQ35DE	
Throttle position	Vehicle speed km/h (MPH)	
	Lock-up ON	Lock-up OFF
Closed throttle	65 - 73 (40 - 45)	62 - 70 (39 - 43)
Half throttle	196 - 204 (122 - 127)	153 - 161 (95 - 100)

- At closed throttle, the accelerator opening is less than 1/8 condition. (Closed throttle position signal: OFF)
- At half throttle, the accelerator opening is 4/8 of the full opening.

### AWD MODELS

Engine model	VQ35DE	
Throttle position	Vehicle speed km/h (MPH)	
	Lock-up ON	Lock-up OFF
Closed throttle	59 - 67 (37 - 42)	56 - 64 (35 - 40)
Half throttle	178 - 186 (111 - 116)	139 - 147 (86 - 91)

# TROUBLE DIAGNOSIS

## < SERVICE INFORMATION >

- At closed throttle, the accelerator opening is less than 1/8 condition. (Closed throttle position signal: OFF)
- At half throttle, the accelerator opening is 4/8 of the full opening.

Engine model	VK45DE	
Throttle position	Vehicle speed km/h (MPH)	
	Lock-up ON	Lock-up OFF
Closed throttle	66 - 74 (41 - 46)	53 - 61 (33 - 38)
Half throttle	191 - 199 (119 - 124)	145 - 153 (90 - 95)

- At closed throttle, the accelerator opening is less than 1/8 condition. (Closed throttle position signal: OFF)
- At half throttle, the accelerator opening is 4/8 of the full opening.

## Symptom Chart

INFOID:000000001327161

- The diagnostics item numbers show the sequence for inspection. Check in order from item 1.
- Overhaul and check inside the A/T only if A/T fluid condition is NG. Refer to [AT-49, "Inspections Before Trouble Diagnosis"](#).

No.	Items	Symptom	Condition	Diagnostic Item	Reference page
1	Shift Shock	Large shock. ("N" → "D" position) Refer to <a href="#">AT-173, "Large Shock ("N" to "D" Position)"</a> .	ON vehicle	1. Engine idle speed	<a href="#">EC-84</a> (for VQ35DE) or <a href="#">EC-661</a> (for VK45DE)
				2. Engine speed signal	<a href="#">AT-112</a>
				3. Accelerator pedal position sensor	<a href="#">AT-130</a>
				4. A/T position	<a href="#">AT-207</a>
				5. A/T fluid temperature sensor	<a href="#">AT-132</a>
				6. Front brake solenoid valve	<a href="#">AT-145</a>
				7. CAN communication line	<a href="#">AT-94</a>
				8. A/T fluid level and state	<a href="#">AT-49</a>
				9. Line pressure test	<a href="#">AT-49</a>
				10. Control valve with TCM	<a href="#">AT-215</a>
			OFF vehicle	11. Forward brake (Parts behind drum support is impossible to perform inspection by disassembly. Refer to <a href="#">AT-16, "Cross-Sectional View (2WD Models)"</a> , <a href="#">AT-17, "Cross-Sectional View (VQ35DE Models for AWD)"</a> or <a href="#">AT-18, "Cross-Sectional View (VK45DE Models for AWD)"</a> )	<a href="#">AT-267</a>
2		Shock is too large when changing D1 → D2 or M1 → M2.	ON vehicle	1. Accelerator pedal position sensor	<a href="#">AT-130</a>
				2. A/T position	<a href="#">AT-207</a>
				3. Direct clutch solenoid valve	<a href="#">AT-147</a>
				4. CAN communication line	<a href="#">AT-94</a>
				5. Engine speed signal	<a href="#">AT-112</a>
				6. Turbine revolution sensor	<a href="#">AT-106</a>
				7. Vehicle speed sensor A/T and vehicle speed sensor MTR	<a href="#">AT-108, AT-137</a>
				8. A/T fluid level and state	<a href="#">AT-49</a>
				9. Control valve with TCM	<a href="#">AT-215</a>
			OFF vehicle	10. Direct clutch	<a href="#">AT-303</a>

# TROUBLE DIAGNOSIS

## < SERVICE INFORMATION >

No.	Items	Symptom	Condition	Diagnostic Item	Reference page
3		Shock is too large when changing D2 → D3 or M2 → M3.	ON vehicle	1. Accelerator pedal position sensor	<a href="#">AT-130</a>
				2. A/T position	<a href="#">AT-207</a>
				3. High and low reverse clutch solenoid valve	<a href="#">AT-149</a>
				4. CAN communication line	<a href="#">AT-94</a>
				5. Engine speed signal	<a href="#">AT-112</a>
				6. Turbine revolution sensor	<a href="#">AT-106</a>
				7. Vehicle speed sensor A/T and vehicle speed sensor MTR	<a href="#">AT-108,</a> <a href="#">AT-137</a>
				8. A/T fluid level and state	<a href="#">AT-49</a>
				9. Control valve with TCM	<a href="#">AT-215</a>
			OFF vehicle	10. High and low reverse clutch	<a href="#">AT-301</a>
4	Shift Shock	Shock is too large when changing D3 → D4 or M3 → M4.	ON vehicle	1. Accelerator pedal position sensor	<a href="#">AT-130</a>
				2. A/T position	<a href="#">AT-207</a>
				3. Input clutch solenoid valve	<a href="#">AT-143</a>
				4. CAN communication line	<a href="#">AT-94</a>
				5. Engine speed signal	<a href="#">AT-112</a>
				6. Turbine revolution sensor	<a href="#">AT-106</a>
				7. Vehicle speed sensor A/T and vehicle speed sensor MTR	<a href="#">AT-108,</a> <a href="#">AT-137</a>
				8. A/T fluid level and state	<a href="#">AT-49</a>
				9. Control valve with TCM	<a href="#">AT-215</a>
			OFF vehicle	10. Input clutch	<a href="#">AT-289</a>
5		Shock is too large when changing D4 → D5 or M4 → M5.	ON vehicle	1. Accelerator pedal position sensor	<a href="#">AT-130</a>
				2. A/T position	<a href="#">AT-207</a>
				3. Front brake solenoid valve	<a href="#">AT-145</a>
				4. CAN communication line	<a href="#">AT-94</a>
				5. Engine speed signal	<a href="#">AT-112</a>
				6. Turbine revolution sensor	<a href="#">AT-106</a>
				7. Vehicle speed sensor A/T and vehicle speed sensor MTR	<a href="#">AT-108,</a> <a href="#">AT-137</a>
				8. A/T fluid level and state	<a href="#">AT-49</a>
				9. Control valve with TCM	<a href="#">AT-215</a>
			OFF vehicle	10. Front brake (brake band)	<a href="#">AT-249</a>
				11. Input clutch	<a href="#">AT-289</a>

# TROUBLE DIAGNOSIS

## < SERVICE INFORMATION >

No.	Items	Symptom	Condition	Diagnostic Item	Reference page
6		Shock is too large for downshift when accelerator pedal is pressed.	ON vehicle	1. Accelerator pedal position sensor	<a href="#">AT-130</a>
				2. A/T position	<a href="#">AT-207</a>
				3. CAN communication line	<a href="#">AT-94</a>
				4. Engine speed signal	<a href="#">AT-112</a>
				5. Turbine revolution sensor	<a href="#">AT-106</a>
				6. Vehicle speed sensor A/T and vehicle speed sensor MTR	<a href="#">AT-108,</a> <a href="#">AT-137</a>
				7. A/T fluid level and state	<a href="#">AT-49</a>
				8. Control valve with TCM	<a href="#">AT-215</a>
			OFF vehicle	9. Front brake (brake band)	<a href="#">AT-249</a>
				10. Input clutch	<a href="#">AT-289</a>
				11. High and low reverse clutch	<a href="#">AT-301</a>
				12. Direct clutch	<a href="#">AT-303</a>
7	Shift Shock	Shock is too large for upshift when accelerator pedal is released.	ON vehicle	1. Accelerator pedal position sensor	<a href="#">AT-130</a>
				2. A/T position	<a href="#">AT-207</a>
				3. Engine speed signal	<a href="#">AT-112</a>
				4. CAN communication line	<a href="#">AT-94</a>
				5. Turbine revolution sensor	<a href="#">AT-106</a>
				6. Vehicle speed sensor A/T and vehicle speed sensor MTR	<a href="#">AT-108,</a> <a href="#">AT-137</a>
				7. A/T fluid level and state	<a href="#">AT-49</a>
				8. Control valve with TCM	<a href="#">AT-215</a>
			OFF vehicle	9. Front brake (brake band)	<a href="#">AT-249</a>
				10. Input clutch	<a href="#">AT-289</a>
				11. High and low reverse clutch	<a href="#">AT-301</a>
				12. Direct clutch	<a href="#">AT-303</a>
8		Shock is too large for lock-up.	ON vehicle	1. Accelerator pedal position sensor	<a href="#">AT-130</a>
				2. A/T position	<a href="#">AT-207</a>
				3. Engine speed signal	<a href="#">AT-112</a>
				4. CAN communication line	<a href="#">AT-94</a>
				5. Turbine revolution sensor	<a href="#">AT-106</a>
				6. Vehicle speed sensor A/T and vehicle speed sensor MTR	<a href="#">AT-108,</a> <a href="#">AT-137</a>
				7. Torque converter clutch solenoid valve	<a href="#">AT-124</a>
				8. A/T fluid level and state	<a href="#">AT-49</a>
				9. Control valve with TCM	<a href="#">AT-215</a>
			OFF vehicle	10. Torque converter	<a href="#">AT-267</a>

A  
B  
AT  
D  
E  
F  
G  
H  
I  
J  
K  
L  
M  
N  
O  
P

# TROUBLE DIAGNOSIS

## < SERVICE INFORMATION >

No.	Items	Symptom	Condition	Diagnostic Item	Reference page
9	Shift Shock	Shock is too large during engine brake.	ON vehicle	1. Accelerator pedal position sensor	<a href="#">AT-130</a>
				2. A/T position	<a href="#">AT-207</a>
				3. CAN communication line	<a href="#">AT-94</a>
				4. A/T fluid level and state	<a href="#">AT-49</a>
				5. Control valve with TCM	<a href="#">AT-215</a>
			OFF vehicle	6. Front brake (brake band)	<a href="#">AT-249</a>
				7. Input clutch	<a href="#">AT-289</a>
				8. High and low reverse clutch	<a href="#">AT-301</a>
				9. Direct clutch	<a href="#">AT-303</a>
10		Gear does not change from D1 to D2 or from M1 to M2. Refer to <a href="#">AT-182</a> , " <a href="#">A/T Does Not Shift: D1→D2</a> ".	ON vehicle	1. A/T fluid level and state	<a href="#">AT-49</a>
				2. Vehicle speed sensor A/T and vehicle speed sensor MTR	<a href="#">AT-137</a>
				3. Direct clutch solenoid valve	<a href="#">AT-147</a>
				4. Line pressure test	<a href="#">AT-49</a>
				5. CAN communication line	<a href="#">AT-94</a>
				6. Control valve with TCM	<a href="#">AT-215</a>
			OFF vehicle	7. Direct clutch	<a href="#">AT-303</a>
11	No Up Shift	Gear does not change from D2 to D3 or from M2 to M3. Refer to <a href="#">AT-184</a> , " <a href="#">A/T Does Not Shift: D2→D3</a> ".	ON vehicle	1. A/T fluid level and state	<a href="#">AT-49</a>
				2. Vehicle speed sensor A/T and vehicle speed sensor MTR	<a href="#">AT-108</a> , <a href="#">AT-137</a>
				3. High and low reverse clutch solenoid valve	<a href="#">AT-149</a>
				4. Line pressure test	<a href="#">AT-49</a>
				5. CAN communication line	<a href="#">AT-94</a>
				6. Control valve with TCM	<a href="#">AT-215</a>
			OFF vehicle	7. High and low reverse clutch	<a href="#">AT-301</a>
12		Gear does not change from D3 to D4 or from M3 to M4. Refer to <a href="#">AT-186</a> , " <a href="#">A/T Does Not Shift: D3→D4</a> ".	ON vehicle	1. A/T fluid level and state	<a href="#">AT-49</a>
				2. Vehicle speed sensor A/T and vehicle speed sensor MTR	<a href="#">AT-108</a> , <a href="#">AT-137</a>
				3. Input clutch solenoid valve	<a href="#">AT-143</a>
				4. Front brake solenoid valve	<a href="#">AT-145</a>
				5. Line pressure test	<a href="#">AT-49</a>
				6. CAN communication line	<a href="#">AT-94</a>
				7. Control valve with TCM	<a href="#">AT-215</a>
			OFF vehicle	8. Input clutch	<a href="#">AT-289</a>
13	No Up Shift	Gear does not change from D4 to D5 or from M4 to M5. Refer to <a href="#">AT-188</a> , " <a href="#">A/T Does Not Shift: D4→D5</a> ".	ON vehicle	1. A/T fluid level and state	<a href="#">AT-49</a>
				2. Vehicle speed sensor A/T and vehicle speed sensor MTR	<a href="#">AT-108</a> , <a href="#">AT-137</a>
				3. Front brake solenoid valve	<a href="#">AT-145</a>
				4. Direct clutch solenoid valve	<a href="#">AT-147</a>
				5. Turbine revolution sensor	<a href="#">AT-106</a>
				6. Line pressure test	<a href="#">AT-49</a>
				7. CAN communication line	<a href="#">AT-94</a>
				8. Control valve with TCM	<a href="#">AT-215</a>
			OFF vehicle	9. Front brake (brake band)	<a href="#">AT-267</a>
				10. Input clutch	<a href="#">AT-289</a>

# TROUBLE DIAGNOSIS

## < SERVICE INFORMATION >

No.	Items	Symptom	Condition	Diagnostic Item	Reference page			
14	No Down Shift	In "D" or "M" position, does not downshift to 4th gear.	ON vehicle	1. A/T fluid level and state	<a href="#">AT-49</a>			
				2. Vehicle speed sensor A/T and vehicle speed sensor MTR	<a href="#">AT-108, AT-137</a>			
				3. Front brake solenoid valve	<a href="#">AT-145</a>			
				4. Direct clutch solenoid valve	<a href="#">AT-147</a>			
				5. CAN communication line	<a href="#">AT-94</a>			
				6. Line pressure test	<a href="#">AT-49</a>			
				7. Control valve with TCM	<a href="#">AT-215</a>			
			OFF vehicle	8. Front brake (brake band)	<a href="#">AT-267</a>			
				9. Input clutch	<a href="#">AT-289</a>			
15	No Down Shift	In "D" or "M" position, does not downshift to 3rd gear.	ON vehicle	1. A/T fluid level and state	<a href="#">AT-49</a>			
				2. Vehicle speed sensor A/T and vehicle speed sensor MTR	<a href="#">AT-108, AT-137</a>			
				3. Input clutch solenoid valve	<a href="#">AT-143</a>			
				4. Front brake solenoid valve	<a href="#">AT-145</a>			
				5. CAN communication line	<a href="#">AT-94</a>			
				6. Line pressure test	<a href="#">AT-49</a>			
				7. Control valve with TCM	<a href="#">AT-215</a>			
			OFF vehicle	8. Input clutch	<a href="#">AT-289</a>			
16	No Down Shift	In "D" or "M" position, does not downshift to 2nd gear.	ON vehicle	1. A/T fluid level and state	<a href="#">AT-49</a>			
				2. Vehicle speed sensor A/T and vehicle speed sensor MTR	<a href="#">AT-108, AT-137</a>			
				3. High and low reverse clutch solenoid valve	<a href="#">AT-149</a>			
				4. CAN communication line	<a href="#">AT-94</a>			
				5. Line pressure test	<a href="#">AT-49</a>			
				6. Control valve with TCM	<a href="#">AT-215</a>			
			OFF vehicle	7. High and low reverse clutch	<a href="#">AT-301</a>			
			17	No Down Shift	In "D" or "M" position, does not downshift to 1st gear.	ON vehicle	1. A/T fluid level and state	<a href="#">AT-49</a>
							2. Vehicle speed sensor A/T and vehicle speed sensor MTR	<a href="#">AT-108, AT-137</a>
							3. Direct clutch solenoid valve	<a href="#">AT-147</a>
							4. CAN communication line	<a href="#">AT-94</a>
							5. Line pressure test	<a href="#">AT-49</a>
6. Control valve with TCM	<a href="#">AT-215</a>							
OFF vehicle	7. Direct clutch	<a href="#">AT-303</a>						

A  
B  
AT  
D  
E  
F  
G  
H  
I  
J  
K  
L  
M  
N  
O  
P

## TROUBLE DIAGNOSIS

### < SERVICE INFORMATION >

No.	Items	Symptom	Condition	Diagnostic Item	Reference page
18	Slips/Will Not Engage	When "D" or "M" position, remains in 1st gear.	ON vehicle	1. A/T fluid level and state	<a href="#">AT-49</a>
				2. Vehicle speed sensor A/T and vehicle speed sensor MTR	<a href="#">AT-108</a> , <a href="#">AT-137</a>
				3. Direct clutch solenoid valve	<a href="#">AT-147</a>
				4. Line pressure test	<a href="#">AT-49</a>
				5. CAN communication line	<a href="#">AT-94</a>
				6. Control valve with TCM	<a href="#">AT-215</a>
			OFF vehicle	7. 3rd one-way clutch	<a href="#">AT-287</a>
				8. 1st one-way clutch	<a href="#">AT-295</a>
				9. Gear system	<a href="#">AT-249</a>
				10. Reverse brake	<a href="#">AT-267</a>
				11. Forward one-way clutch (Parts behind drum support is impossible to perform inspection by disassembly. Refer to <a href="#">AT-16</a> . "Cross-Sectional View (2WD Models)", <a href="#">AT-17</a> . "Cross-Sectional View (VQ35DE Models for AWD)" or <a href="#">AT-18</a> . "Cross-Sectional View (VK45DE Models for AWD)")	<a href="#">AT-267</a>
				12. Forward brake (Parts behind drum support is impossible to perform inspection by disassembly. Refer to <a href="#">AT-16</a> . "Cross-Sectional View (2WD Models)", <a href="#">AT-17</a> . "Cross-Sectional View (VQ35DE Models for AWD)" or <a href="#">AT-18</a> . "Cross-Sectional View (VK45DE Models for AWD)")	<a href="#">AT-267</a>



# TROUBLE DIAGNOSIS

## < SERVICE INFORMATION >

No.	Items	Symptom	Condition	Diagnostic Item	Reference page
19		When "D" or "M" position, remains in 2nd gear.	ON vehicle	1. A/T fluid level and state	<a href="#">AT-49</a>
				2. Vehicle speed sensor A/T and vehicle speed sensor MTR	<a href="#">AT-108, AT-137</a>
				3. Low coast brake solenoid valve	<a href="#">AT-151</a>
				4. Line pressure test	<a href="#">AT-49</a>
				5. CAN communication line	<a href="#">AT-94</a>
				6. Control valve with TCM	<a href="#">AT-215</a>
			OFF vehicle	7. 3rd one-way clutch	<a href="#">AT-287</a>
				8. Gear system	<a href="#">AT-249</a>
				9. Direct clutch	<a href="#">AT-303</a>
				10. Forward brake (Parts behind drum support is impossible to perform inspection by disassembly. Refer to <a href="#">AT-16, "Cross-Sectional View (2WD Models)"</a> , <a href="#">AT-17, "Cross-Sectional View (VQ35DE Models for AWD)"</a> or <a href="#">AT-18, "Cross-Sectional View (VK45DE Models for AWD)"</a> )	<a href="#">AT-267</a>
20	Slips/Will Not Engage	When "D" or "M" position, remains in 3rd gear.	ON vehicle	1. A/T fluid level and state	<a href="#">AT-49</a>
				2. Vehicle speed sensor A/T and vehicle speed sensor MTR	<a href="#">AT-108, AT-137</a>
				3. Line pressure test	<a href="#">AT-49</a>
				4. CAN communication line	<a href="#">AT-94</a>
				5. Control valve with TCM	<a href="#">AT-215</a>
			OFF vehicle	6. 3rd one-way clutch	<a href="#">AT-287</a>
				7. Gear system	<a href="#">AT-249</a>
				8. High and low reverse clutch	<a href="#">AT-301</a>
				9. Forward one-way clutch (Parts behind drum support is impossible to perform inspection by disassembly. Refer to <a href="#">AT-16, "Cross-Sectional View (2WD Models)"</a> , <a href="#">AT-17, "Cross-Sectional View (VQ35DE Models for AWD)"</a> or <a href="#">AT-18, "Cross-Sectional View (VK45DE Models for AWD)"</a> )	<a href="#">AT-267</a>
				10. Forward brake (Parts behind drum support is impossible to perform inspection by disassembly. Refer to <a href="#">AT-16, "Cross-Sectional View (2WD Models)"</a> , <a href="#">AT-17, "Cross-Sectional View (VQ35DE Models for AWD)"</a> or <a href="#">AT-18, "Cross-Sectional View (VK45DE Models for AWD)"</a> )	<a href="#">AT-267</a>

A  
B  
AT  
D  
E  
F  
G  
H  
I  
J  
K  
L  
M  
N  
O  
P

# TROUBLE DIAGNOSIS

## < SERVICE INFORMATION >

No.	Items	Symptom	Condition	Diagnostic Item	Reference page
21	Slips/Will Not Engage	When "D" or "M" position, remains in 4th gear.	ON vehicle	1. A/T fluid level and state	<a href="#">AT-49</a>
				2. Vehicle speed sensor A/T and vehicle speed sensor MTR	<a href="#">AT-108</a> , <a href="#">AT-137</a>
				3. Input clutch solenoid valve	<a href="#">AT-143</a>
				4. Direct clutch solenoid valve	<a href="#">AT-147</a>
				5. High and low reverse clutch solenoid valve	<a href="#">AT-149</a>
				6. Low coast brake solenoid valve	<a href="#">AT-151</a>
				7. Front brake solenoid valve	<a href="#">AT-145</a>
				8. Line pressure test	<a href="#">AT-49</a>
				9. CAN communication line	<a href="#">AT-94</a>
				10. Control valve with TCM	<a href="#">AT-215</a>
			OFF vehicle	11. Input clutch	<a href="#">AT-289</a>
				12. Gear system	<a href="#">AT-249</a>
				13. High and low reverse clutch	<a href="#">AT-301</a>
				14. Direct clutch	<a href="#">AT-303</a>
22		When "D" or "M" position, remains in 5th gear.	ON vehicle	1. A/T fluid level and state	<a href="#">AT-49</a>
				2. Vehicle speed sensor A/T and vehicle speed sensor MTR	<a href="#">AT-108</a> , <a href="#">AT-137</a>
				3. Front brake solenoid valve	<a href="#">AT-145</a>
				4. Line pressure test	<a href="#">AT-49</a>
				5. CAN communication line	<a href="#">AT-94</a>
				6. Control valve with TCM	<a href="#">AT-215</a>
			OFF vehicle	7. Front brake (brake band)	<a href="#">AT-267</a>
				8. Input clutch	<a href="#">AT-289</a>
				9. Gear system	<a href="#">AT-249</a>
				10. High and low reverse clutch	<a href="#">AT-301</a>

# TROUBLE DIAGNOSIS

## < SERVICE INFORMATION >

No.	Items	Symptom	Condition	Diagnostic Item	Reference page
23	Slips/Will Not Engage	Vehicle cannot be started from D1. Refer to <a href="#">AT-180, "Vehicle Cannot Be Started from D1"</a> .	ON vehicle	1. A/T fluid level and state	<a href="#">AT-49</a>
				2. Accelerator pedal position sensor	<a href="#">AT-130</a>
				3. Line pressure test	<a href="#">AT-49</a>
				4. CAN communication line	<a href="#">AT-94</a>
				5. Control valve with TCM	<a href="#">AT-215</a>
			OFF vehicle	6. Torque converter	<a href="#">AT-267</a>
				7. Oil pump assembly	<a href="#">AT-285</a>
				8. 3rd one-way clutch	<a href="#">AT-287</a>
				9. 1st one-way clutch	<a href="#">AT-295</a>
				10. Gear system	<a href="#">AT-249</a>
				11. Reverse brake	<a href="#">AT-267</a>
				12. Forward one-way clutch (Parts behind drum support is impossible to perform inspection by disassembly. Refer to <a href="#">AT-16, "Cross-Sectional View (2WD Models)"</a> , <a href="#">AT-17, "Cross-Sectional View (VQ35DE Models for AWD)"</a> or <a href="#">AT-18, "Cross-Sectional View (VK45DE Models for AWD)"</a> )	<a href="#">AT-267</a>
				13. Forward brake (Parts behind drum support is impossible to perform inspection by disassembly. Refer to <a href="#">AT-16, "Cross-Sectional View (2WD Models)"</a> , <a href="#">AT-17, "Cross-Sectional View (VQ35DE Models for AWD)"</a> or <a href="#">AT-18, "Cross-Sectional View (VK45DE Models for AWD)"</a> )	<a href="#">AT-267</a>
24	Does not lock-up. Refer to <a href="#">AT-190, "A/T Does Not Lock-up"</a> .	ON vehicle	1. A/T fluid level and state	<a href="#">AT-49</a>	
			2. Line pressure test	<a href="#">AT-49</a>	
			3. Engine speed signal	<a href="#">AT-112</a>	
			4. Turbine revolution sensor	<a href="#">AT-106</a>	
			5. Torque converter clutch solenoid valve	<a href="#">AT-124</a>	
			6. CAN communication line	<a href="#">AT-94</a>	
			7. Control valve with TCM	<a href="#">AT-215</a>	
OFF vehicle	8. Torque converter	<a href="#">AT-267</a>			
	9. Oil pump assembly	<a href="#">AT-285</a>			
25	Does not hold lock-up condition. Refer to <a href="#">AT-192, "A/T Does Not Hold Lock-up Condition"</a> .	ON vehicle	1. A/T fluid level and state	<a href="#">AT-49</a>	
			2. Line pressure test	<a href="#">AT-49</a>	
			3. Engine speed signal	<a href="#">AT-112</a>	
			4. Turbine revolution sensor	<a href="#">AT-106</a>	
			5. Torque converter clutch solenoid valve	<a href="#">AT-124</a>	
			6. CAN communication line	<a href="#">AT-94</a>	
			7. Control valve with TCM	<a href="#">AT-215</a>	
		OFF vehicle	8. Torque converter	<a href="#">AT-267</a>	
			9. Oil pump assembly	<a href="#">AT-285</a>	

A  
B  
AT  
D  
E  
F  
G  
H  
I  
J  
K  
L  
M  
N  
O  
P

# TROUBLE DIAGNOSIS

## < SERVICE INFORMATION >

No.	Items	Symptom	Condition	Diagnostic Item	Reference page
26		Lock-up is not released. Refer to <a href="#">AT-194</a> , " <a href="#">Lock-up Is Not Released</a> ".	ON vehicle	1. A/T fluid level and state	<a href="#">AT-49</a>
				2. Line pressure test	<a href="#">AT-49</a>
				3. Engine speed signal	<a href="#">AT-112</a>
				4. Turbine revolution sensor	<a href="#">AT-106</a>
				5. Torque converter clutch solenoid valve	<a href="#">AT-124</a>
				6. CAN communication line	<a href="#">AT-94</a>
				7. Control valve with TCM	<a href="#">AT-215</a>
			OFF vehicle	8. Torque converter	<a href="#">AT-267</a>
				9. Oil pump assembly	<a href="#">AT-285</a>
27	Slips/Will Not Engage	No shock at all or the clutch slips when vehicle changes speed D1 → D2 or M1 → M2.	ON vehicle	1. A/T fluid level and state	<a href="#">AT-49</a>
				2. Vehicle speed sensor A/T and vehicle speed sensor MTR	<a href="#">AT-108</a> , <a href="#">AT-137</a>
				3. Direct clutch solenoid valve	<a href="#">AT-147</a>
				4. CAN communication line	<a href="#">AT-94</a>
				5. Line pressure test	<a href="#">AT-49</a>
				6. Control valve with TCM	<a href="#">AT-215</a>
			OFF vehicle	7. Torque converter	<a href="#">AT-267</a>
				8. Oil pump assembly	<a href="#">AT-285</a>
				9. 3rd one-way clutch	<a href="#">AT-287</a>
				10. Gear system	<a href="#">AT-249</a>
				11. Direct clutch	<a href="#">AT-303</a>
				12. Forward brake (Parts behind drum support is impossible to perform inspection by disassembly. Refer to <a href="#">AT-16</a> , " <a href="#">Cross-Sectional View (2WD Models)</a> ", <a href="#">AT-17</a> , " <a href="#">Cross-Sectional View (VQ35DE Models for AWD)</a> " or <a href="#">AT-18</a> , " <a href="#">Cross-Sectional View (VK45DE Models for AWD)</a> ")	<a href="#">AT-267</a>

# TROUBLE DIAGNOSIS

## < SERVICE INFORMATION >

No.	Items	Symptom	Condition	Diagnostic Item	Reference page	
28	Slips/Will Not Engage	No shock at all or the clutch slips when vehicle changes speed D2 → D3 or M2 → M3.	ON vehicle	1. A/T fluid level and state	<a href="#">AT-49</a>	A
				2. Vehicle speed sensor A/T and vehicle speed sensor MTR	<a href="#">AT-108</a> , <a href="#">AT-137</a>	B
				3. High and low reverse clutch solenoid valve	<a href="#">AT-149</a>	AT
				4. CAN communication line	<a href="#">AT-94</a>	
				5. Line pressure test	<a href="#">AT-49</a>	
				6. Control valve with TCM	<a href="#">AT-215</a>	
			OFF vehicle	7. Torque converter	<a href="#">AT-267</a>	D
				8. Oil pump assembly	<a href="#">AT-285</a>	
				9. 3rd one-way clutch	<a href="#">AT-287</a>	E
				10. Gear system	<a href="#">AT-249</a>	
				11. High and low reverse clutch	<a href="#">AT-301</a>	
				12. Forward one-way clutch (Parts behind drum support is impossible to perform inspection by disassembly. Refer to <a href="#">AT-16</a> , " <a href="#">Cross-Sectional View (2WD Models)</a> ", <a href="#">AT-17</a> , " <a href="#">Cross-Sectional View (VQ35DE Models for AWD)</a> " or <a href="#">AT-18</a> , " <a href="#">Cross-Sectional View (VK45DE Models for AWD)</a> ")	<a href="#">AT-267</a>	F
				13. Forward brake (Parts behind drum support is impossible to perform inspection by disassembly. Refer to <a href="#">AT-16</a> , " <a href="#">Cross-Sectional View (2WD Models)</a> ", <a href="#">AT-17</a> , " <a href="#">Cross-Sectional View (VQ35DE Models for AWD)</a> " or <a href="#">AT-18</a> , " <a href="#">Cross-Sectional View (VK45DE Models for AWD)</a> ")	<a href="#">AT-267</a>	H
29	Slips/Will Not Engage	No shock at all or the clutch slips when vehicle changes speed D3 → D4 or M3 → M4.	ON vehicle	1. A/T fluid level and state	<a href="#">AT-49</a>	I
				2. Vehicle speed sensor A/T and vehicle speed sensor MTR	<a href="#">AT-108</a> , <a href="#">AT-137</a>	J
				3. Input clutch solenoid valve	<a href="#">AT-143</a>	
				4. Front brake solenoid valve	<a href="#">AT-145</a>	
				5. CAN communication line	<a href="#">AT-94</a>	K
				6. Line pressure test	<a href="#">AT-49</a>	
				7. Control valve with TCM	<a href="#">AT-215</a>	
			OFF vehicle	8. Torque converter	<a href="#">AT-267</a>	L
				9. Oil pump assembly	<a href="#">AT-285</a>	
				10. Input clutch	<a href="#">AT-289</a>	M
				11. Gear system	<a href="#">AT-249</a>	
				12. High and low reverse clutch	<a href="#">AT-301</a>	
				13. Direct clutch	<a href="#">AT-303</a>	N

# TROUBLE DIAGNOSIS

## < SERVICE INFORMATION >

No.	Items	Symptom	Condition	Diagnostic Item	Reference page
30	Slips/Will Not Engage	No shock at all or the clutch slips when vehicle changes speed D4 → D5 or M4 → M5.	ON vehicle	1. A/T fluid level and state	<a href="#">AT-49</a>
				2. Vehicle speed sensor A/T and vehicle speed sensor MTR	<a href="#">AT-108</a> , <a href="#">AT-137</a>
				3. Front brake solenoid valve	<a href="#">AT-145</a>
				4. Direct clutch solenoid valve	<a href="#">AT-147</a>
				5. CAN communication line	<a href="#">AT-94</a>
				6. Line pressure test	<a href="#">AT-49</a>
				7. Control valve with TCM	<a href="#">AT-215</a>
			OFF vehicle	8. Torque converter	<a href="#">AT-267</a>
				9. Oil pump assembly	<a href="#">AT-285</a>
				10. Front brake (brake band)	<a href="#">AT-267</a>
				11. Input clutch	<a href="#">AT-289</a>
				12. Gear system	<a href="#">AT-249</a>
				13. High and low reverse clutch	<a href="#">AT-301</a>
31	Slips/Will Not Engage	When you press the accelerator pedal and shift speed D5 → D4 or M5 → M4 the engine idles or the A/T slips.	ON vehicle	1. A/T fluid level and state	<a href="#">AT-49</a>
				2. Vehicle speed sensor A/T and vehicle speed sensor MTR	<a href="#">AT-108</a> , <a href="#">AT-137</a>
				3. Front brake solenoid valve	<a href="#">AT-145</a>
				4. Direct clutch solenoid valve	<a href="#">AT-147</a>
				5. CAN communication line	<a href="#">AT-94</a>
				6. Line pressure test	<a href="#">AT-49</a>
				7. Control valve with TCM	<a href="#">AT-215</a>
			OFF vehicle	8. Torque converter	<a href="#">AT-267</a>
				9. Oil pump assembly	<a href="#">AT-285</a>
				10. Input clutch	<a href="#">AT-289</a>
				11. Gear system	<a href="#">AT-249</a>
				12. High and low reverse clutch	<a href="#">AT-301</a>
				13. Direct clutch	<a href="#">AT-303</a>

# TROUBLE DIAGNOSIS

## < SERVICE INFORMATION >

No.	Items	Symptom	Condition	Diagnostic Item	Reference page
32	Slips/Will Not Engage	When pressing the accelerator pedal and shifting speed D4 → D3 or M4 → M3 the engine idles or the A/T slips.	ON vehicle	1. A/T fluid level and state	<a href="#">AT-49</a>
				2. Vehicle speed sensor A/T and vehicle speed sensor MTR	<a href="#">AT-108, AT-137</a>
				3. Input clutch solenoid valve	<a href="#">AT-143</a>
				4. Front brake solenoid valve	<a href="#">AT-145</a>
				5. CAN communication line	<a href="#">AT-94</a>
				6. Line pressure test	<a href="#">AT-49</a>
				7. Control valve with TCM	<a href="#">AT-215</a>
			OFF vehicle	8. Torque converter	<a href="#">AT-267</a>
				9. Oil pump assembly	<a href="#">AT-285</a>
				10. 3rd one-way clutch	<a href="#">AT-287</a>
				11. Gear system	<a href="#">AT-249</a>
				12. High and low reverse clutch	<a href="#">AT-301</a>
				13. Forward one-way clutch (Parts behind drum support is impossible to perform inspection by disassembly. Refer to <a href="#">AT-16, "Cross-Sectional View (2WD Models)"</a> , <a href="#">AT-17, "Cross-Sectional View (VQ35DE Models for AWD)"</a> or <a href="#">AT-18, "Cross-Sectional View (VK45DE Models for AWD)"</a> )	<a href="#">AT-267</a>
				14. Forward brake (Parts behind drum support is impossible to perform inspection by disassembly. Refer to <a href="#">AT-16, "Cross-Sectional View (2WD Models)"</a> , <a href="#">AT-17, "Cross-Sectional View (VQ35DE Models for AWD)"</a> or <a href="#">AT-18, "Cross-Sectional View (VK45DE Models for AWD)"</a> )	<a href="#">AT-267</a>
33	Slips/Will Not Engage	When pressing the accelerator pedal and shifting speed D3 → D2 or M3 → M2 the engine idles or the A/T slips.	ON vehicle	1. A/T fluid level and state	<a href="#">AT-49</a>
				2. Vehicle speed sensor A/T and vehicle speed sensor MTR	<a href="#">AT-108, AT-137</a>
				3. High and low reverse clutch solenoid valve	<a href="#">AT-149</a>
				4. Direct clutch solenoid valve	<a href="#">AT-147</a>
				5. CAN communication line	<a href="#">AT-94</a>
				6. Line pressure test	<a href="#">AT-49</a>
				7. Control valve with TCM	<a href="#">AT-215</a>
			OFF vehicle	8. Torque converter	<a href="#">AT-267</a>
				9. Oil pump assembly	<a href="#">AT-285</a>
				10. 3rd one-way clutch	<a href="#">AT-287</a>
				11. Gear system	<a href="#">AT-249</a>
				12. Direct clutch	<a href="#">AT-303</a>
				13. Forward brake (Parts behind drum support is impossible to perform inspection by disassembly. Refer to <a href="#">AT-16, "Cross-Sectional View (2WD Models)"</a> , <a href="#">AT-17, "Cross-Sectional View (VQ35DE Models for AWD)"</a> or <a href="#">AT-18, "Cross-Sectional View (VK45DE Models for AWD)"</a> )	<a href="#">AT-267</a>

A  
B  
AT  
D  
E  
F  
G  
H  
I  
J  
K  
L  
M  
N  
O  
P

# TROUBLE DIAGNOSIS

## < SERVICE INFORMATION >

No.	Items	Symptom	Condition	Diagnostic Item	Reference page
34	Slips/Will Not Engage	When pressing the accelerator pedal and shifting speed D2 → D1 or M2 → M1 the engine idles or the A/T slips.	ON vehicle	1. A/T fluid level and state	<a href="#">AT-49</a>
				2. Vehicle speed sensor A/T and vehicle speed sensor MTR	<a href="#">AT-108</a> , <a href="#">AT-137</a>
				3. Direct clutch solenoid valve	<a href="#">AT-147</a>
				4. CAN communication line	<a href="#">AT-94</a>
				5. Line pressure test	<a href="#">AT-49</a>
				6. Control valve with TCM	<a href="#">AT-215</a>
			OFF vehicle	7. Torque converter	<a href="#">AT-267</a>
				8. Oil pump assembly	<a href="#">AT-285</a>
				9. 3rd one-way clutch	<a href="#">AT-287</a>
				10. 1st one-way clutch	<a href="#">AT-295</a>
				11. Gear system	<a href="#">AT-249</a>
				12. Reverse brake	<a href="#">AT-267</a>
				13. Forward one-way clutch (Parts behind drum support is impossible to perform inspection by disassembly. Refer to <a href="#">AT-16</a> , " <a href="#">Cross-Sectional View (2WD Models)</a> ", <a href="#">AT-17</a> , " <a href="#">Cross-Sectional View (VQ35DE Models for AWD)</a> " or <a href="#">AT-18</a> , " <a href="#">Cross-Sectional View (VK45DE Models for AWD)</a> ")	<a href="#">AT-267</a>
				14. Forward brake (Parts behind drum support is impossible to perform inspection by disassembly. Refer to <a href="#">AT-16</a> , " <a href="#">Cross-Sectional View (2WD Models)</a> ", <a href="#">AT-17</a> , " <a href="#">Cross-Sectional View (VQ35DE Models for AWD)</a> " or <a href="#">AT-18</a> , " <a href="#">Cross-Sectional View (VK45DE Models for AWD)</a> ")	<a href="#">AT-267</a>
35	With selector lever in "D" position, acceleration is extremely poor.	ON vehicle	1. A/T fluid level and state	<a href="#">AT-49</a>	
			2. Line pressure test	<a href="#">AT-49</a>	
			3. Accelerator pedal position sensor	<a href="#">AT-130</a>	
			4. CAN communication line	<a href="#">AT-94</a>	
			5. PNP switch	<a href="#">AT-102</a>	
			6. A/T position	<a href="#">AT-207</a>	
			7. Control valve with TCM	<a href="#">AT-215</a>	
		OFF vehicle	8. Torque converter	<a href="#">AT-267</a>	
			9. Oil pump assembly	<a href="#">AT-285</a>	
			10. 1st one-way clutch	<a href="#">AT-295</a>	
			11. Gear system	<a href="#">AT-249</a>	
			12. Reverse brake	<a href="#">AT-267</a>	
			13. Forward one-way clutch (Parts behind drum support is impossible to perform inspection by disassembly. Refer to <a href="#">AT-16</a> , " <a href="#">Cross-Sectional View (2WD Models)</a> ", <a href="#">AT-17</a> , " <a href="#">Cross-Sectional View (VQ35DE Models for AWD)</a> " or <a href="#">AT-18</a> , " <a href="#">Cross-Sectional View (VK45DE Models for AWD)</a> ")	<a href="#">AT-267</a>	
			14. Forward brake (Parts behind drum support is impossible to perform inspection by disassembly. Refer to <a href="#">AT-16</a> , " <a href="#">Cross-Sectional View (2WD Models)</a> ", <a href="#">AT-17</a> , " <a href="#">Cross-Sectional View (VQ35DE Models for AWD)</a> " or <a href="#">AT-18</a> , " <a href="#">Cross-Sectional View (VK45DE Models for AWD)</a> ")	<a href="#">AT-267</a>	



# TROUBLE DIAGNOSIS

## < SERVICE INFORMATION >

No.	Items	Symptom	Condition	Diagnostic Item	Reference page
36		With selector lever in "R" position, acceleration is extremely poor.	ON vehicle	1. A/T fluid level and state	<a href="#">AT-49</a>
				2. Line pressure test	<a href="#">AT-49</a>
				3. Accelerator pedal position sensor	<a href="#">AT-130</a>
				4. High and low reverse clutch solenoid valve	<a href="#">AT-149</a>
				5. CAN communication line	<a href="#">AT-94</a>
				6. PNP switch	<a href="#">AT-102</a>
				7. A/T position	<a href="#">AT-207</a>
				8. Control valve with TCM	<a href="#">AT-215</a>
			OFF vehicle	9. Gear system	<a href="#">AT-249</a>
				10. Output shaft	<a href="#">AT-267</a>
				11. Reverse brake	<a href="#">AT-267</a>
37	Slips/Will Not Engage	While starting off by accelerating in 1st, engine races or slippage occurs.	ON vehicle	1. A/T fluid level and state	<a href="#">AT-49</a>
				2. Line pressure test	<a href="#">AT-49</a>
				3. Accelerator pedal position sensor	<a href="#">AT-130</a>
				4. CAN communication line	<a href="#">AT-94</a>
				5. Control valve with TCM	<a href="#">AT-215</a>
			OFF vehicle	6. Torque converter	<a href="#">AT-267</a>
				7. Oil pump assembly	<a href="#">AT-285</a>
				8. 3rd one-way clutch	<a href="#">AT-287</a>
				9. 1st one-way clutch	<a href="#">AT-295</a>
				10. Gear system	<a href="#">AT-249</a>
				11. Reverse brake	<a href="#">AT-267</a>
				12. Forward one-way clutch (Parts behind drum support is impossible to perform inspection by disassembly. Refer to <a href="#">AT-16</a> , " <a href="#">Cross-Sectional View (2WD Models)</a> ", <a href="#">AT-17</a> , " <a href="#">Cross-Sectional View (VQ35DE Models for AWD)</a> " or <a href="#">AT-18</a> , " <a href="#">Cross-Sectional View (VK45DE Models for AWD)</a> ")	<a href="#">AT-267</a>
				13. Forward brake (Parts behind drum support is impossible to perform inspection by disassembly. Refer to <a href="#">AT-16</a> , " <a href="#">Cross-Sectional View (2WD Models)</a> ", <a href="#">AT-17</a> , " <a href="#">Cross-Sectional View (VQ35DE Models for AWD)</a> " or <a href="#">AT-18</a> , " <a href="#">Cross-Sectional View (VK45DE Models for AWD)</a> ")	<a href="#">AT-267</a>

A  
B  
AT  
D  
E  
F  
G  
H  
I  
J  
K  
L  
M  
N  
O  
P

# TROUBLE DIAGNOSIS

## < SERVICE INFORMATION >

No.	Items	Symptom	Condition	Diagnostic Item	Reference page
38		While accelerating in 2nd, engine races or slippage occurs.	ON vehicle	1. A/T fluid level and state	<a href="#">AT-49</a>
				2. Line pressure test	<a href="#">AT-49</a>
				3. Accelerator pedal position sensor	<a href="#">AT-130</a>
				4. CAN communication line	<a href="#">AT-94</a>
				5. Direct clutch solenoid valve	<a href="#">AT-147</a>
				6. Control valve with TCM	<a href="#">AT-215</a>
			OFF vehicle	7. Torque converter	<a href="#">AT-267</a>
				8. Oil pump assembly	<a href="#">AT-285</a>
				9. 3rd one-way clutch	<a href="#">AT-287</a>
				10. Gear system	<a href="#">AT-249</a>
				11. Direct clutch	<a href="#">AT-303</a>
				12. Forward brake (Parts behind drum support is impossible to perform inspection by disassembly. Refer to <a href="#">AT-16</a> , " <a href="#">Cross-Sectional View (2WD Models)</a> ", <a href="#">AT-17</a> , " <a href="#">Cross-Sectional View (VQ35DE Models for AWD)</a> " or <a href="#">AT-18</a> , " <a href="#">Cross-Sectional View (VK45DE Models for AWD)</a> ")	<a href="#">AT-267</a>
39	Slips/Will Not Engage	While accelerating in 3rd, engine races or slippage occurs.	ON vehicle	1. A/T fluid level and state	<a href="#">AT-49</a>
				2. Line pressure test	<a href="#">AT-49</a>
				3. Accelerator pedal position sensor	<a href="#">AT-130</a>
				4. CAN communication line	<a href="#">AT-94</a>
				5. High and low reverse clutch solenoid valve	<a href="#">AT-149</a>
				6. Control valve with TCM	<a href="#">AT-215</a>
			OFF vehicle	7. Torque converter	<a href="#">AT-267</a>
				8. Oil pump assembly	<a href="#">AT-285</a>
				9. 3rd one-way clutch	<a href="#">AT-287</a>
				10. Gear system	<a href="#">AT-249</a>
				11. High and low reverse clutch	<a href="#">AT-301</a>
				12. Forward one-way clutch (Parts behind drum support is impossible to perform inspection by disassembly. Refer to <a href="#">AT-16</a> , " <a href="#">Cross-Sectional View (2WD Models)</a> ", <a href="#">AT-17</a> , " <a href="#">Cross-Sectional View (VQ35DE Models for AWD)</a> " or <a href="#">AT-18</a> , " <a href="#">Cross-Sectional View (VK45DE Models for AWD)</a> ")	<a href="#">AT-267</a>
13. Forward brake (Parts behind drum support is impossible to perform inspection by disassembly. Refer to <a href="#">AT-16</a> , " <a href="#">Cross-Sectional View (2WD Models)</a> ", <a href="#">AT-17</a> , " <a href="#">Cross-Sectional View (VQ35DE Models for AWD)</a> " or <a href="#">AT-18</a> , " <a href="#">Cross-Sectional View (VK45DE Models for AWD)</a> ")	<a href="#">AT-267</a>				

# TROUBLE DIAGNOSIS

## < SERVICE INFORMATION >

No.	Items	Symptom	Condition	Diagnostic Item	Reference page
40		While accelerating in 4th, engine races or slippage occurs.	ON vehicle	1. A/T fluid level and state	<a href="#">AT-49</a>
				2. Line pressure test	<a href="#">AT-49</a>
				3. Accelerator pedal position sensor	<a href="#">AT-130</a>
				4. CAN communication line	<a href="#">AT-94</a>
				5. Input clutch solenoid valve	<a href="#">AT-143</a>
				6. Control valve with TCM	<a href="#">AT-215</a>
			OFF vehicle	7. Torque converter	<a href="#">AT-267</a>
				8. Oil pump assembly	<a href="#">AT-285</a>
				9. Input clutch	<a href="#">AT-289</a>
				10. Gear system	<a href="#">AT-249</a>
				11. High and low reverse clutch	<a href="#">AT-301</a>
				12. Direct clutch	<a href="#">AT-303</a>
41	Slips/Will Not Engage	While accelerating in 5th, engine races or slippage occurs.	ON vehicle	1. A/T fluid level and state	<a href="#">AT-49</a>
				2. Line pressure test	<a href="#">AT-49</a>
				3. Accelerator pedal position sensor	<a href="#">AT-130</a>
				4. CAN communication line	<a href="#">AT-94</a>
				5. Front brake solenoid valve	<a href="#">AT-145</a>
				6. Control valve with TCM	<a href="#">AT-215</a>
			OFF vehicle	7. Torque converter	<a href="#">AT-267</a>
				8. Oil pump assembly	<a href="#">AT-285</a>
				9. Front brake (brake band)	<a href="#">AT-267</a>
				10. Input clutch	<a href="#">AT-289</a>
				11. Gear system	<a href="#">AT-249</a>
				12. High and low reverse clutch	<a href="#">AT-301</a>
42		Slips at lock-up.	ON vehicle	1. A/T fluid level and state	<a href="#">AT-49</a>
				2. Line pressure test	<a href="#">AT-49</a>
				3. Engine speed signal	<a href="#">AT-112</a>
				4. Turbine revolution sensor	<a href="#">AT-106</a>
				5. Torque converter clutch solenoid valve	<a href="#">AT-124</a>
				6. CAN communication line	<a href="#">AT-94</a>
				7. Control valve with TCM	<a href="#">AT-215</a>
			OFF vehicle	8. Torque converter	<a href="#">AT-267</a>
				9. Oil pump assembly	<a href="#">AT-285</a>

A  
B  
AT  
D  
E  
F  
G  
H  
I  
J  
K  
L  
M  
N  
O  
P

# TROUBLE DIAGNOSIS

## < SERVICE INFORMATION >

No.	Items	Symptom	Condition	Diagnostic Item	Reference page
43	Slips/Will Not Engage	No creep at all. Refer to <a href="#">AT-175, "Vehicle Does Not Creep Backward in "R" Position"</a> , <a href="#">AT-178, "Vehicle Does Not Creep Forward in "D" Position"</a>	ON vehicle	1. A/T fluid level and state	<a href="#">AT-49</a>
				2. Line pressure test	<a href="#">AT-49</a>
				3. Accelerator pedal position sensor	<a href="#">AT-130</a>
				4. Direct clutch solenoid valve	<a href="#">AT-147</a>
				5. PNP switch	<a href="#">AT-102</a>
				6. CAN communication line	<a href="#">AT-94</a>
				7. A/T position	<a href="#">AT-207</a>
				8. Control valve with TCM	<a href="#">AT-215</a>
			OFF vehicle	9. Torque converter	<a href="#">AT-267</a>
				10. Oil pump assembly	<a href="#">AT-285</a>
				11. 1st one-way clutch	<a href="#">AT-295</a>
				12. Gear system	<a href="#">AT-249</a>
				13. Reverse brake	<a href="#">AT-267</a>
				14. Direct clutch	<a href="#">AT-303</a>
				15. Forward one-way clutch (Parts behind drum support is impossible to perform inspection by disassembly. Refer to <a href="#">AT-16, "Cross-Sectional View (2WD Models)"</a> , <a href="#">AT-17, "Cross-Sectional View (VQ35DE Models for AWD)"</a> or <a href="#">AT-18, "Cross-Sectional View (VK45DE Models for AWD)"</a> )	<a href="#">AT-267</a>
				16. Forward brake (Parts behind drum support is impossible to perform inspection by disassembly. Refer to <a href="#">AT-16, "Cross-Sectional View (2WD Models)"</a> , <a href="#">AT-17, "Cross-Sectional View (VQ35DE Models for AWD)"</a> or <a href="#">AT-18, "Cross-Sectional View (VK45DE Models for AWD)"</a> )	<a href="#">AT-267</a>
44	Vehicle cannot run in all positions.		ON vehicle	1. A/T fluid level and state	<a href="#">AT-49</a>
				2. Line pressure test	<a href="#">AT-49</a>
				3. PNP switch	<a href="#">AT-102</a>
				4. A/T position	<a href="#">AT-207</a>
				5. Control valve with TCM	<a href="#">AT-215</a>
			OFF vehicle	6. Oil pump assembly	<a href="#">AT-285</a>
				7. Gear system	<a href="#">AT-249</a>
				8. Output shaft	<a href="#">AT-267</a>

# TROUBLE DIAGNOSIS

## < SERVICE INFORMATION >

No.	Items	Symptom	Condition	Diagnostic Item	Reference page
45	Slips/Will Not Engage	With selector lever in "D" position, driving is not possible.	ON vehicle	1. A/T fluid level and state	<a href="#">AT-49</a>
				2. Line pressure test	<a href="#">AT-49</a>
				3. PNP switch	<a href="#">AT-102</a>
				4. A/T position	<a href="#">AT-207</a>
				5. Control valve with TCM	<a href="#">AT-215</a>
			OFF vehicle	6. Torque converter	<a href="#">AT-267</a>
				7. Oil pump assembly	<a href="#">AT-285</a>
				8. 1st one-way clutch	<a href="#">AT-295</a>
				9. Gear system	<a href="#">AT-249</a>
				10. Reverse brake	<a href="#">AT-267</a>
				11. Forward one-way clutch (Parts behind drum support is impossible to perform inspection by disassembly. Refer to <a href="#">AT-16</a> , " <a href="#">Cross-Sectional View (2WD Models)</a> ", <a href="#">AT-17</a> , " <a href="#">Cross-Sectional View (VQ35DE Models for AWD)</a> " or <a href="#">AT-18</a> , " <a href="#">Cross-Sectional View (VK45DE Models for AWD)</a> ")	<a href="#">AT-267</a>
				12. Forward brake (Parts behind drum support is impossible to perform inspection by disassembly. Refer to <a href="#">AT-16</a> , " <a href="#">Cross-Sectional View (2WD Models)</a> ", <a href="#">AT-17</a> , " <a href="#">Cross-Sectional View (VQ35DE Models for AWD)</a> " or <a href="#">AT-18</a> , " <a href="#">Cross-Sectional View (VK45DE Models for AWD)</a> ")	<a href="#">AT-267</a>
46		With selector lever in "R" position, driving is not possible.	ON vehicle	1. A/T fluid level and state	<a href="#">AT-49</a>
				2. Line pressure test	<a href="#">AT-49</a>
				3. PNP switch	<a href="#">AT-102</a>
				4. A/T position	<a href="#">AT-207</a>
				5. Control valve with TCM	<a href="#">AT-215</a>
			OFF vehicle	6. Gear system	<a href="#">AT-249</a>
				7. Output shaft	<a href="#">AT-267</a>
				8. Reverse brake	<a href="#">AT-267</a>
47	Does Not Change	Does not change M5 → M4. Refer to <a href="#">AT-196</a> , " <a href="#">A/T Does Not Shift: 5th Gear → 4th Gear</a> ".	ON vehicle	1. PNP switch	<a href="#">AT-102</a>
				2. A/T fluid level and state	<a href="#">AT-49</a>
				3. A/T position	<a href="#">AT-207</a>
				4. Manual mode switch	<a href="#">AT-155</a>
				5. CAN communication line	<a href="#">AT-94</a>
				6. Control valve with TCM	<a href="#">AT-215</a>
			OFF vehicle	7. Front brake (brake band)	<a href="#">AT-267</a>

A  
B  
AT  
D  
E  
F  
G  
H  
I  
J  
K  
L  
M  
N  
O  
P

# TROUBLE DIAGNOSIS

## < SERVICE INFORMATION >

No.	Items	Symptom	Condition	Diagnostic Item	Reference page			
48	Does Not Change	Does not change M4 → M3. Refer to <a href="#">AT-197, "A/T Does Not Shift: 4th Gear → 3rd Gear"</a> .	ON vehicle	1. PNP switch	<a href="#">AT-102</a>			
				2. A/T fluid level and state	<a href="#">AT-49</a>			
				3. A/T position	<a href="#">AT-207</a>			
				4. Manual mode switch	<a href="#">AT-155</a>			
				5. CAN communication line	<a href="#">AT-94</a>			
				6. Control valve with TCM	<a href="#">AT-215</a>			
49		Does not change M3 → M2. Refer to <a href="#">AT-199, "A/T Does Not Shift: 3rd Gear → 2nd Gear"</a> .	OFF vehicle	7. Front brake (brake band)	<a href="#">AT-267</a>			
				8. Input clutch	<a href="#">AT-289</a>			
				50	Does not change M2 → M1. Refer to <a href="#">AT-201, "A/T Does Not Shift: 2nd Gear → 1st Gear"</a> .	ON vehicle	1. PNP switch	<a href="#">AT-102</a>
							2. A/T fluid level and state	<a href="#">AT-49</a>
							3. A/T position	<a href="#">AT-207</a>
							4. Manual mode switch	<a href="#">AT-155</a>
5. CAN communication line	<a href="#">AT-94</a>							
6. Control valve with TCM	<a href="#">AT-215</a>							
51	Cannot be changed to manual mode. Refer to <a href="#">AT-195, "Can-not Be Changed to Manual Mode"</a> .	OFF vehicle	7. Input clutch	<a href="#">AT-289</a>				
			8. High and low reverse clutch	<a href="#">AT-301</a>				
			9. Direct clutch	<a href="#">AT-303</a>				
52	Others	Shift point is high in "D" position.	ON vehicle	1. Manual mode switch		<a href="#">AT-155</a>		
				2. Turbine revolution sensor		<a href="#">AT-106</a>		
				3. CAN communication line		<a href="#">AT-94</a>		
				1. Vehicle speed sensor A/T and vehicle speed sensor MTR	<a href="#">AT-108, AT-137</a>			
				2. Accelerator pedal position sensor	<a href="#">AT-130</a>			
				3. CAN communication line	<a href="#">AT-94</a>			
				4. ATF temperature sensor	<a href="#">AT-132</a>			
				5. Control valve with TCM	<a href="#">AT-215</a>			

# TROUBLE DIAGNOSIS

## < SERVICE INFORMATION >

No.	Items	Symptom	Condition	Diagnostic Item	Reference page			
53		Shift point is low in "D" position.	ON vehicle	1. Vehicle speed sensor A/T and vehicle speed sensor MTR	<a href="#">AT-108</a> , <a href="#">AT-137</a>			
				2. Accelerator pedal position sensor	<a href="#">AT-130</a>			
				3. CAN communication line	<a href="#">AT-94</a>			
				4. Control valve with TCM	<a href="#">AT-215</a>			
54		Judder occurs during lock-up.	ON vehicle	1. A/T fluid level and state	<a href="#">AT-49</a>			
				2. Engine speed signal	<a href="#">AT-112</a>			
				3. Turbine revolution sensor	<a href="#">AT-106</a>			
				4. Vehicle speed sensor A/T and vehicle speed sensor MTR	<a href="#">AT-108</a> , <a href="#">AT-137</a>			
			OFF vehicle	5. Accelerator pedal position sensor	<a href="#">AT-130</a>			
				6. CAN communication line	<a href="#">AT-94</a>			
				7. Torque converter clutch solenoid valve	<a href="#">AT-124</a>			
				8. Control valve with TCM	<a href="#">AT-215</a>			
55	Others	Strange noise in "R" position.	ON vehicle	9. Torque converter	<a href="#">AT-267</a>			
				OFF vehicle	1. A/T fluid level and state	<a href="#">AT-49</a>		
					2. Engine speed signal	<a href="#">AT-112</a>		
					3. CAN communication line	<a href="#">AT-94</a>		
			4. Control valve with TCM		<a href="#">AT-215</a>			
			56		Strange noise in "N" position.	ON vehicle	5. Torque converter	<a href="#">AT-267</a>
							6. Oil pump assembly	<a href="#">AT-285</a>
							7. Gear system	<a href="#">AT-249</a>
							8. High and low reverse clutch	<a href="#">AT-301</a>
OFF vehicle	9. Reverse brake	<a href="#">AT-267</a>						
	1. A/T fluid level and state	<a href="#">AT-49</a>						
			ON vehicle	2. Engine speed signal	<a href="#">AT-112</a>			
				3. CAN communication line	<a href="#">AT-94</a>			
				4. Control valve with TCM	<a href="#">AT-215</a>			
			OFF vehicle	5. Torque converter	<a href="#">AT-267</a>			
				6. Oil pump assembly	<a href="#">AT-285</a>			
				7. Gear system	<a href="#">AT-249</a>			

A  
B  
AT  
D  
E  
F  
G  
H  
I  
J  
K  
L  
M  
N  
O  
P

# TROUBLE DIAGNOSIS

## < SERVICE INFORMATION >

No.	Items	Symptom	Condition	Diagnostic Item	Reference page				
57		Strange noise in "D" position.	ON vehicle	1. A/T fluid level and state	<a href="#">AT-49</a>				
				2. Engine speed signal	<a href="#">AT-112</a>				
				3. CAN communication line	<a href="#">AT-94</a>				
				4. Control valve with TCM	<a href="#">AT-215</a>				
			OFF vehicle	5. Torque converter	<a href="#">AT-267</a>				
				6. Oil pump assembly	<a href="#">AT-285</a>				
				7. Gear system	<a href="#">AT-249</a>				
				8. Forward brake (Parts behind drum support is impossible to perform inspection by disassembly. Refer to <a href="#">AT-16</a> , " <a href="#">Cross-Sectional View (2WD Models)</a> ", <a href="#">AT-17</a> , " <a href="#">Cross-Sectional View (VQ35DE Models for AWD)</a> " or <a href="#">AT-18</a> , " <a href="#">Cross-Sectional View (VK45DE Models for AWD)</a> ")	<a href="#">AT-267</a>				
58	Others	Vehicle does not decelerate by engine brake. Refer to <a href="#">AT-202</a> , " <a href="#">Vehicle Does Not Decelerate by Engine Brake</a> ".	ON vehicle	1. PNP switch	<a href="#">AT-102</a>				
				2. A/T fluid level and state	<a href="#">AT-49</a>				
				3. A/T position	<a href="#">AT-207</a>				
				4. Manual mode switch	<a href="#">AT-155</a>				
				5. CAN communication line	<a href="#">AT-94</a>				
				6. Control valve with TCM	<a href="#">AT-215</a>				
			OFF vehicle	7. Input clutch	<a href="#">AT-289</a>				
				8. High and low reverse clutch	<a href="#">AT-301</a>				
				9. Direct clutch	<a href="#">AT-303</a>				
				59		Engine brake does not work M5 → M4.	ON vehicle	1. PNP switch	<a href="#">AT-102</a>
								2. A/T fluid level and state	<a href="#">AT-49</a>
								3. A/T position	<a href="#">AT-207</a>
4. Manual mode switch	<a href="#">AT-155</a>								
5. CAN communication line	<a href="#">AT-94</a>								
6. Control valve with TCM	<a href="#">AT-215</a>								
OFF vehicle	7. Front brake (brake band)	<a href="#">AT-267</a>							
60		Engine brake does not work M4 → M3.	ON vehicle	1. PNP switch	<a href="#">AT-102</a>				
				2. A/T fluid level and state	<a href="#">AT-49</a>				
				3. A/T position	<a href="#">AT-207</a>				
				4. Manual mode switch	<a href="#">AT-155</a>				
				5. CAN communication line	<a href="#">AT-94</a>				
				6. Control valve with TCM	<a href="#">AT-215</a>				
			OFF vehicle	7. Front brake (brake band)	<a href="#">AT-267</a>				
				8. Input clutch	<a href="#">AT-289</a>				



# TROUBLE DIAGNOSIS

## < SERVICE INFORMATION >

No.	Items	Symptom	Condition	Diagnostic Item	Reference page
61		Engine brake does not work M3 → M2.	ON vehicle	1. PNP switch	<a href="#">AT-102</a>
				2. A/T fluid level and state	<a href="#">AT-49</a>
				3. A/T position	<a href="#">AT-207</a>
				4. Manual mode switch	<a href="#">AT-155</a>
				5. CAN communication line	<a href="#">AT-94</a>
				6. Control valve with TCM	<a href="#">AT-215</a>
			OFF vehicle	7. Front brake (brake band)	<a href="#">AT-267</a>
				8. Input clutch	<a href="#">AT-289</a>
				9. High and low reverse clutch	<a href="#">AT-301</a>
62		Engine brake does not work M2 → M1.	ON vehicle	1. PNP switch	<a href="#">AT-102</a>
				2. A/T fluid level and state	<a href="#">AT-49</a>
				3. A/T position	<a href="#">AT-207</a>
				4. Manual mode switch	<a href="#">AT-155</a>
				5. CAN communication line	<a href="#">AT-94</a>
				6. Control valve with TCM	<a href="#">AT-215</a>
			OFF vehicle	7. Input clutch	<a href="#">AT-289</a>
				8. High and low reverse clutch	<a href="#">AT-301</a>
				9. Direct clutch	<a href="#">AT-303</a>
63	Others	Maximum speed low.	ON vehicle	1. A/T fluid level and state	<a href="#">AT-49</a>
				2. Line pressure test	<a href="#">AT-49</a>
				3. Accelerator pedal position sensor	<a href="#">AT-130</a>
				4. CAN communication line	<a href="#">AT-94</a>
				5. Direct clutch solenoid valve	<a href="#">AT-147</a>
				6. Control valve with TCM	<a href="#">AT-215</a>
			OFF vehicle	7. Torque converter	<a href="#">AT-267</a>
				8. Oil pump assembly	<a href="#">AT-285</a>
				9. Input clutch	<a href="#">AT-289</a>
				10. Gear system	<a href="#">AT-249</a>
				11. High and low reverse clutch	<a href="#">AT-301</a>
				12. Direct clutch	<a href="#">AT-303</a>
		13. Forward one-way clutch (Parts behind drum support is impossible to perform inspection by disassembly. Refer to <a href="#">AT-16</a> , " <a href="#">Cross-Sectional View (2WD Models)</a> ", <a href="#">AT-17</a> , " <a href="#">Cross-Sectional View (VQ35DE Models for AWD)</a> " or <a href="#">AT-18</a> , " <a href="#">Cross-Sectional View (VK45DE Models for AWD)</a> ")	<a href="#">AT-267</a>		
		14. Forward brake (Parts behind drum support is impossible to perform inspection by disassembly. Refer to <a href="#">AT-16</a> , " <a href="#">Cross-Sectional View (2WD Models)</a> ", <a href="#">AT-17</a> , " <a href="#">Cross-Sectional View (VQ35DE Models for AWD)</a> " or <a href="#">AT-18</a> , " <a href="#">Cross-Sectional View (VK45DE Models for AWD)</a> ")	<a href="#">AT-267</a>		

A  
B  
AT  
D  
E  
F  
G  
H  
I  
J  
K  
L  
M  
N  
O  
P

# TROUBLE DIAGNOSIS

## < SERVICE INFORMATION >

No.	Items	Symptom	Condition	Diagnostic Item	Reference page	
64		Extremely large creep.	ON vehicle	1. Engine idle speed	<a href="#">EC-84</a> (for VQ35DE) or <a href="#">EC-661</a> (for VK45DE)	
			OFF vehicle	2. CAN communication line	<a href="#">AT-94</a>	
65	Others	With selector lever in "P" position, vehicle does not enter parking condition or, with selector lever in another position, parking condition is not cancelled. Refer to <a href="#">AT-171</a> , " <a href="#">In "P" Position, Vehicle Moves When Pushed</a> ".	ON vehicle	1. PNP switch	<a href="#">AT-102</a>	
			OFF vehicle	2. A/T position	<a href="#">AT-207</a>	
66	Others	Vehicle runs with A/T in "P" position.	ON vehicle	3. Torque converter	<a href="#">AT-267</a>	
				3. Parking pawl components	<a href="#">AT-226</a> (2WD models) or <a href="#">AT-267</a> (AWD models)	
			OFF vehicle	1. PNP switch	<a href="#">AT-102</a>	
				2. A/T fluid level and state	<a href="#">AT-49</a>	
67	Others	Vehicle runs with A/T in "N" position. Refer to <a href="#">AT-172</a> , " <a href="#">In "N" Position, Vehicle Moves</a> ".	ON vehicle	3. A/T position	<a href="#">AT-207</a>	
				4. Control valve with TCM	<a href="#">AT-215</a>	
				OFF vehicle	5. Parking pawl components	<a href="#">AT-226</a> (2WD models) or <a href="#">AT-267</a> (AWD models)
					6. Gear system	<a href="#">AT-249</a>
			OFF vehicle	5. Input clutch	<a href="#">AT-289</a>	
				6. Gear system	<a href="#">AT-249</a>	
				7. Direct clutch	<a href="#">AT-303</a>	
				8. Reverse brake	<a href="#">AT-267</a>	
				9. Forward one-way clutch (Parts behind drum support is impossible to perform inspection by disassembly. Refer to <a href="#">AT-16</a> , " <a href="#">Cross-Sectional View (2WD Models)</a> ", <a href="#">AT-17</a> , " <a href="#">Cross-Sectional View (VQ35DE Models for AWD)</a> " or <a href="#">AT-18</a> , " <a href="#">Cross-Sectional View (VK45DE Models for AWD)</a> ")	<a href="#">AT-267</a>	
				10. Low coast brake (Parts behind drum support is impossible to perform inspection by disassembly. Refer to <a href="#">AT-16</a> , " <a href="#">Cross-Sectional View (2WD Models)</a> ", <a href="#">AT-17</a> , " <a href="#">Cross-Sectional View (VQ35DE Models for AWD)</a> " or <a href="#">AT-18</a> , " <a href="#">Cross-Sectional View (VK45DE Models for AWD)</a> ")	<a href="#">AT-267</a>	

# TROUBLE DIAGNOSIS

## < SERVICE INFORMATION >

No.	Items	Symptom	Condition	Diagnostic Item	Reference page
68		Engine does not start in "N" or "P" position. Refer to <a href="#">AT-170</a> , " <a href="#">Engine Cannot Be Started in "P" or "N" Position</a> ".	ON vehicle	1. Ignition switch and starter	<a href="#">PG-3, SC-8</a>
				2. A/T position	<a href="#">AT-207</a>
				3. PNP switch	<a href="#">AT-102</a>
69		Engine starts in positions other than "N" or "P".	ON vehicle	1. Ignition switch and starter	<a href="#">PG-3, SC-8</a>
				2. A/T position	<a href="#">AT-207</a>
				3. PNP switch	<a href="#">AT-102</a>
70		Engine stall.	ON vehicle	1. A/T fluid level and state	<a href="#">AT-49</a>
				2. Engine speed signal	<a href="#">AT-112</a>
				3. Turbine revolution sensor	<a href="#">AT-106</a>
				4. Torque converter clutch solenoid valve	<a href="#">AT-124</a>
				5. CAN communication line	<a href="#">AT-94</a>
				6. Control valve with TCM	<a href="#">AT-215</a>
71	Others	Engine stalls when selector lever shifted "N" → "D", "R".	ON vehicle	1. A/T fluid level and state	<a href="#">AT-49</a>
				2. Engine speed signal	<a href="#">AT-112</a>
				3. Turbine revolution sensor	<a href="#">AT-106</a>
				4. Torque converter clutch solenoid valve	<a href="#">AT-124</a>
				5. CAN communication line	<a href="#">AT-94</a>
				6. Control valve with TCM	<a href="#">AT-215</a>
			OFF vehicle	7. Torque converter	<a href="#">AT-267</a>
72		Engine speed does not return to idle. Refer to <a href="#">AT-194</a> , " <a href="#">Engine Speed Does Not Return to Idle</a> ".	ON vehicle	1. A/T fluid level and state	<a href="#">AT-49</a>
				2. Direct clutch solenoid valve	<a href="#">AT-147</a>
				3. Front brake solenoid valve	<a href="#">AT-145</a>
				4. Accelerator pedal position sensor	<a href="#">AT-130</a>
				5. Vehicle speed sensor A/T and vehicle speed sensor MTR	<a href="#">AT-137</a>
				6. CAN communication line	<a href="#">AT-94</a>
				7. Control valve with TCM	<a href="#">AT-215</a>
			OFF vehicle	8. Front brake (brake band)	<a href="#">AT-267</a>
			9. Direct clutch	<a href="#">AT-303</a>	

## TCM Input/Output Signal Reference Value

INFOID:000000001327162

## A/T ASSEMBLY HARNESS CONNECTOR TERMINAL LAYOUT

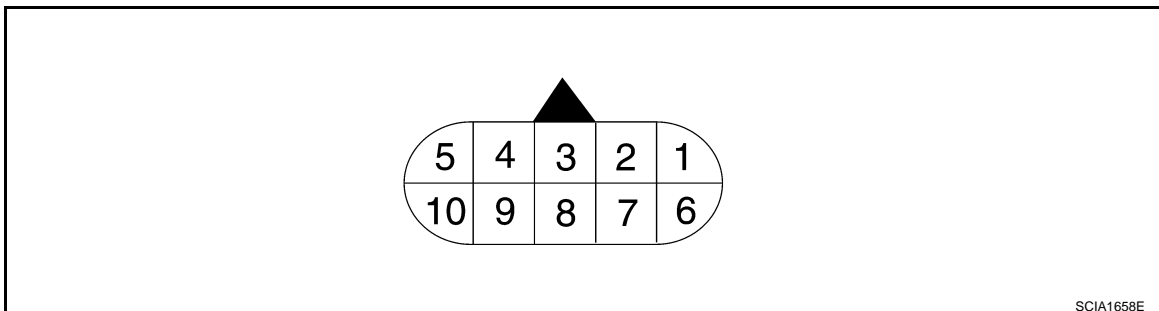







SCIA1658E

## TCM INSPECTION TABLE

# TROUBLE DIAGNOSIS

## < SERVICE INFORMATION >

Data are reference value and are measured between each terminal and ground.

Terminal	Wire color	Item	Condition	Data (Approx.)
1	LG	Power supply (Memory back-up)	Always	Battery voltage
2	LG	Power supply (Memory back-up)	Always	Battery voltage
3	L	CAN-H	-	-
4	PU	K-line (CONSULT-III signal)	The terminal is connected to the data link connector for CONSULT-III.	
5	B	Ground	-	-
6	Y	Power supply	 -	Battery voltage
			 -	0 V
7	OR	Back-up lamp relay	 Selector lever in "R" position.	0 V
			 Selector lever in other positions.	Battery voltage
8	P	CAN-L	-	-
9	GY	Starter relay	 Selector lever in "N" and "P" positions.	Battery voltage
			 Selector lever in other positions.	0 V
10	B	Ground	-	-

## CONSULT-III Function (TRANSMISSION)

INFOID:000000001327163

CONSULT-III can display each diagnostic item using the diagnostic test models shown following.

### FUNCTION

Diagnostic test mode	Function
Work support	This mode enables a technician to adjust some devices faster and more accurately by following the indications on CONSULT-III.
Self-diagnostic results	Self-diagnostic results can be read and erased quickly.
Data monitor	Input/Output data in the ECU can be read.
CAN diagnostic support monitor	The results of transmit/receive diagnosis of CAN communication can be read.
Function test	Performed by CONSULT-III instead of a technician to determine whether each system is "OK" or "NG".
DTC work support	Select the operating condition to confirm Diagnosis Trouble Codes.
ECU part number	TCM part number can be read.

### CONSULT-III REFERENCE VALUE

#### NOTICE:

- The CONSULT-III electrically displays shift timing and lock-up timing (that is, operation timing of each solenoid).  
Check for time difference between actual shift timing and the CONSULT-III display. If the difference is noticeable, mechanical parts (except solenoids, sensors, etc.) may be malfunctioning. Check mechanical parts using applicable diagnostic procedures.
- Shift schedule (which implies gear position) displayed on CONSULT-III and that indicated in Service Manual may differ slightly. This occurs because of the following reasons:
  - Actual shift schedule has more or less tolerance or allowance,
  - Shift schedule indicated in Service Manual refers to the point where shifts start, and
  - Gear position displayed on CONSULT-III indicates the point where shifts are completed.

## TROUBLE DIAGNOSIS

### < SERVICE INFORMATION >

3. Display of solenoid valves on CONSULT-III changes at the start of shifting, while gear position is displayed upon completion of shifting (which is computed by TCM).

Item name	Condition	Display value (Approx.)	
ATF TEMP SE 1	0°C (32°F) – 20°C (68°F) – 80°C (176°F)	3.3 – 2.7 – 0.9 V	A
ATF TEMP SE 2		3.3 – 2.5 – 0.7 V	B
ATF TEMP 1	Ignition switch ON	Measured ATF temperature is displayed.	AT
TCC SOLENOID	Lock-up is active	0.4 – 0.6 A	
SLCT LVR POSI	Selector lever in “N” and “P” positions.	N/P	D
	Selector lever in “R” position.	R	
	Selector lever in “D” position.	D	
VHCL/S SE-A/T	During driving	Approximately matches the speedometer reading.	E
VEHICLE SPEED	During driving	Approximately matches the speedometer reading.	F
ENGINE SPEED	Engine running	Closely matches the tachometer reading.	
LINE PRES SOL	During driving	0.2 – 0.6 A	G
TURBINE REV	During driving (lock-up ON)	Approximately matches the engine speed.	
VHCL/S SE-MTR	During driving	Approximately matches the speedometer reading.	H
ATF PRES SW 2	Low coast brake engaged. Refer to <a href="#">AT-18</a> .	ON	I
	Low coast brake disengaged. Refer to <a href="#">AT-18</a> .	OFF	
I/C SOLENOID	Input clutch disengaged. Refer to <a href="#">AT-18</a> .	0.6 – 0.8 A	J
	Input clutch engaged. Refer to <a href="#">AT-18</a> .	0 – 0.05 A	
FR/B SOLENOID	Front brake engaged. Refer to <a href="#">AT-18</a> .	0.6 – 0.8 A	K
	Front brake disengaged. Refer to <a href="#">AT-18</a> .	0 – 0.05 A	
D/C SOLENOID	Direct clutch disengaged. Refer to <a href="#">AT-18</a> .	0.6 – 0.8 A	L
	Direct clutch engaged. Refer to <a href="#">AT-18</a> .	0 – 0.05 A	
HLR/C SOL	High and low reverse clutch disengaged. Refer to <a href="#">AT-18</a> .	0.6 – 0.8 A	M
	High and low reverse clutch engaged. Refer to <a href="#">AT-18</a> .	0 – 0.05 A	
ON OFF SOL	Low coast brake engaged. Refer to <a href="#">AT-18</a> .	ON	N
	Low coast brake disengaged. Refer to <a href="#">AT-18</a> .	OFF	
MANU MODE SW	Manual shift gate position (neutral)	ON	O
	Other than the above	OFF	
NON M-MODE SW	Manual shift gate position	OFF	P
	Other than the above	ON	
UP SW LEVER	Selector lever: + side	ON	
	Other than the above	OFF	
DOWN SW LEVER	Selector lever: - side	ON	
	Other than the above	OFF	
STARTER RELAY	Selector lever in “N” and “P” positions.	ON	
	Selector lever in other positions.	OFF	
ACCELE POSI	Released accelerator pedal.	0.0/8	
	Fully depressed accelerator pedal.	8.0/8	

# TROUBLE DIAGNOSIS

## < SERVICE INFORMATION >

Item name	Condition	Display value (Approx.)
CLSD THL POS	Released accelerator pedal.	ON
	Fully depressed accelerator pedal.	OFF
W/O THL POS	Fully depressed accelerator pedal.	ON
	Released accelerator pedal.	OFF
BRAKE SW	Depressed brake pedal.	ON.
	Released brake pedal.	OFF
GEAR	During driving.	1,2,3,4,5,

### SELF-DIAGNOSTIC RESULT MODE

After performing "SELF-DIAGNOSTIC RESULT MODE", place check marks for results on the [AT-42. "How to Perform Trouble Diagnosis for Quick and Accurate Repair"](#). Reference pages are provided following the items.

#### Display Items List

X: Applicable, —: Not applicable

Items (CONSULT-III screen terms)	Malfunction is detected when...	TCM self-diagnosis	OBD-II (DTC)	Reference page
		"TRANSMISSION" with CONSULT-III	MIL indicator lamp <sup>(*)</sup> , "ENGINE" with CONSULT-III or GST	
CAN COMM CIRCUIT	When TCM is not transmitting or receiving CAN communication signal for 2 seconds or more.	U1000	U1000	<a href="#">AT-94</a>
STARTER RELAY/CIRC	If this signal is ON other than in "P" or "N" position, this is judged to be a malfunction. (And if it is OFF in "P" or "N" position, this too is judged to be a malfunction.)	P0615	—	<a href="#">AT-97</a>
TCM	TCM is malfunctioning.	P0700	P0700	<a href="#">AT-101</a>
PNP SW/CIRC	<ul style="list-style-type: none"> <li>PNP switch 1-4 signals input with impossible pattern.</li> <li>"P" position is detected from "N" position without any other position being detected in between.</li> </ul>	P0705	P0705	<a href="#">AT-102</a>
TURBINE REV S/CIRC	<ul style="list-style-type: none"> <li>TCM does not receive the proper voltage signal from the sensor.</li> <li>TCM detects an irregularity only at position of 4th gear for turbine revolution sensor 2.</li> </ul>	P0717	P0717	<a href="#">AT-106</a>
VEH SPD SEN/CIR AT	<ul style="list-style-type: none"> <li>Signal from vehicle speed sensor A/T (Revolution sensor) not input due to cut line or the like.</li> <li>Unexpected signal input during running.</li> <li>After ignition switch is turned ON, unexpected signal input from vehicle speed sensor MTR before the vehicle starts moving.</li> </ul>	P0720	P0720	<a href="#">AT-108</a>
ENGINE SPEED SIG	TCM does not receive the CAN communication signal from the ECM.	P0725	P0725	<a href="#">AT-112</a>
A/T 1ST GR FNCTN	A/T cannot shift to 1st gear.	P0731	P0731	<a href="#">AT-114</a>
A/T 2ND GR FNCTN	A/T cannot shift to 2nd gear.	P0732	P0732	<a href="#">AT-116</a>
A/T 3RD GR FNCTN	A/T cannot shift to 3rd gear.	P0733	P0733	<a href="#">AT-118</a>
A/T 4TH GR FNCTN	A/T cannot shift to 4th gear.	P0734	P0734	<a href="#">AT-120</a>
A/T 5TH GR FNCTN	A/T cannot shift to 5th gear.	P0735	P0735	<a href="#">AT-122</a>
TCC SOLENOID/CIRC	Normal voltage not applied to solenoid due to cut line, short, or the like.	P0740	P0740	<a href="#">AT-124</a>

# TROUBLE DIAGNOSIS

## < SERVICE INFORMATION >

Items (CONSULT-III screen terms)	Malfunction is detected when...	TCM self-diagnosis	OBD-II (DTC)	Reference page
		"TRANSMISSION" with CONSULT-III	MIL indicator lamp <sup>(*)</sup> , "ENGINE" with CONSULT-III or GST	
A/T TCC S/V FNCTN	<ul style="list-style-type: none"> <li>A/T cannot perform lock-up even if electrical circuit is good.</li> <li>TCM detects as irregular by comparing difference value with slip rotation.</li> </ul>	P0744	P0744 <sup>(*)2</sup>	<a href="#">AT-126</a>
L/PRESS SOL/CIRC	<ul style="list-style-type: none"> <li>Normal voltage not applied to solenoid due to cut line, short, or the like.</li> <li>TCM detects as irregular by comparing target value with monitor value.</li> </ul>	P0745	P0745	<a href="#">AT-128</a>
TP SEN/CIRC A/T	TCM does not receive the proper accelerator pedal position signals (input by CAN communication) from ECM.	P1705	P1705	<a href="#">AT-130</a>
ATF TEMP SEN/CIRC	During running, the A/T fluid temperature sensor signal voltage is excessively high or low.	P1710	P0710	<a href="#">AT-132</a>
VEH SPD SE/CIR-MTR	<ul style="list-style-type: none"> <li>Signal (CAN communication) from vehicle speed sensor MTR not input due to cut line or the like.</li> <li>Unexpected signal input during running.</li> </ul>	P1721	—	<a href="#">AT-137</a>
A/T INTERLOCK	Except during shift change, the gear position and ATF pressure switch states are monitored and comparative judgement made.	P1730	P1730	<a href="#">AT-139</a>
A/T 1ST E/BRAKING	Each ATF pressure switch and solenoid current is monitored and if a pattern is detected having engine braking 1st gear other than in the M1 position, a malfunction is detected.	P1731	—	<a href="#">AT-141</a>
I/C SOLENOID/CIRC	<ul style="list-style-type: none"> <li>Normal voltage not applied to solenoid due to functional malfunction, cut line, short, or the like.</li> <li>TCM detects as irregular by comparing target value with monitor value.</li> </ul>	P1752	P1752	<a href="#">AT-143</a>
FR/B SOLENOID/CIRC	<ul style="list-style-type: none"> <li>Normal voltage not applied to solenoid due to functional malfunction, cut line, short, or the like.</li> <li>TCM detects as irregular by comparing target value with monitor value.</li> </ul>	P1757	P1757	<a href="#">AT-145</a>
D/C SOLENOID/CIRC	<ul style="list-style-type: none"> <li>Normal voltage not applied to solenoid due to cut line, short, or the like.</li> <li>TCM detects as irregular by comparing target value with monitor value.</li> </ul>	P1762	P1762	<a href="#">AT-147</a>
HLR/C SOL/CIRC	<ul style="list-style-type: none"> <li>Normal voltage not applied to solenoid due to functional malfunction, cut line, short, or the like.</li> <li>TCM detects as irregular by comparing target value with monitor value.</li> </ul>	P1767	P1767	<a href="#">AT-149</a>
LC/B SOLENOID/CIRC	Normal voltage not applied to solenoid due to functional malfunction, cut line, short, or the like.	P1772	P1772	<a href="#">AT-151</a>
LC/B SOLENOID FNCT	<ul style="list-style-type: none"> <li>TCM detects an improper voltage drop when it tries to operate the solenoid valve.</li> <li>Condition of ATF pressure switch 2 is different from monitor value, and relation between gear position and actual gear ratio is irregular.</li> </ul>	P1774	P1774 <sup>(*)2</sup>	<a href="#">AT-153</a>
MANU MODE SW/CIRC	When an impossible pattern of switch signals is detected, a malfunction is detected.	P1815	—	<a href="#">AT-155</a>
NO DTC IS DETECTED FURTHER TESTING MAY BE REQUIRED	No NG item has been detected.	X	X	—

\*1: Refer to [EC-71, "Malfunction Indicator Lamp \(MIL\)"](#) (for VQ35DE engine) or [EC-649, "Malfunction Indicator Lamp \(MIL\)"](#) (for VK45DE engine.)

# TROUBLE DIAGNOSIS

## < SERVICE INFORMATION >

\*2: These malfunctions cannot be displayed MIL if another malfunction is assigned to MIL.

### DATA MONITOR MODE

#### Display Items List

X: Standard, —: Not applicable, ▼: Option

Monitored item (Unit)	Select Monitor Item			Remarks
	ECU INPUT SIGNALS	MAIN SIGNALS	SELECTION FROM MENU	
VHCL/S SE-A/T (km/h)	X	X	▼	Revolution sensor
VHCL/S SE-MTR (km/h)	X	—	▼	
ACCELE POSI (0.0/8)	X	—	▼	Accelerator pedal position signal
THROTTLE POSI (0.0/8)	X	X	▼	Degree of opening for accelerator recognized by the TCM For fail-safe operation, the specific value used for control is displayed.
CLSD THL POS (ON/OFF)	X	—	▼	Signal input with CAN communications
W/O THL POS (ON/OFF)	X	—	▼	
BRAKE SW (ON/OFF)	X	—	▼	Stop lamp switch
GEAR	—	X	▼	Gear position recognized by the TCM updated after gear-shifting
ENGINE SPEED (rpm)	X	X	▼	
TURBINE REV (rpm)	X	X	▼	
OUTPUT REV (rpm)	X	X	▼	
GEAR RATIO	—	X	▼	
TC SLIP SPEED (rpm)	—	X	▼	Difference between engine speed and torque converter input shaft speed
F SUN GR REV (rpm)	—	—	▼	
F CARR GR REV (rpm)	—	—	▼	
ATF TEMP SE 1 (V)	X	—	▼	
ATF TEMP SE 2 (V)	X	—	▼	
ATF TEMP 1 (°C)	—	X	▼	
ATF TEMP 2 (°C)	—	X	▼	
BATTERY VOLT (V)	X	—	▼	
ATF PRES SW 1 (ON/OFF)	X	X	▼	(for FR/B solenoid)
ATF PRES SW 2 (ON/OFF)	X	X	▼	(for LC/B solenoid)
ATF PRES SW 3 (ON/OFF)	X	X	▼	(for I/C solenoid)
ATF PRES SW 5 (ON/OFF)	X	X	▼	(for D/C solenoid)
ATF PRES SW 6 (ON/OFF)	X	X	▼	(for HLR/C solenoid)
PNP SW 1 (ON/OFF)	X	—	▼	
PNP SW 2 (ON/OFF)	X	—	▼	
PNP SW 3 (ON/OFF)	X	—	▼	
PNP SW 4 (ON/OFF)	X	—	▼	



# TROUBLE DIAGNOSIS

## < SERVICE INFORMATION >

Monitored item (Unit)	Select Monitor Item			Remarks	
	ECU INPUT SIGNALS	MAIN SIGNALS	SELECTION FROM MENU		
1 POSITION SW (ON/OFF)	X	—	▼		A
SLCT LVR POSI	—	X	▼	Selector lever position is recognized by the TCM. For fail-safe operation, the specific value used for control is displayed.	B AT
OD CONT SW (ON/OFF)	X	—	▼	Not mounted but displayed.	D
POWERSHIFT SW (ON/OFF)	X	—	▼		
HOLD SW (ON/OFF)	X	—	▼		
MANU MODE SW (ON/OFF)	X	—	▼		E
NON M-MODE SW (ON/OFF)	X	—	▼		
UP SW LEVER (ON/OFF)	X	—	▼		F
DOWN SW LEVER (ON/OFF)	X	—	▼		
SFT UP ST SW (ON/OFF)	—	—	▼	Not mounted but displayed.	G
SFT DWN ST SW (ON/OFF)	—	—	▼		
ASCD-OD CUT (ON/OFF)	—	—	▼		H
ASCD-CRUISE (ON/OFF)	—	—	▼		
ABS SIGNAL (ON/OFF)	—	—	▼	ICC (intelligent cruise control)	I
ACC-OD CUT (ON/OFF)	—	—	▼		
ACC-SIGNAL (ON/OFF)	—	—	▼		
TCS GR/P KEEP (ON/OFF)	—	—	▼		J
TCS SIGNAL 2 (ON/OFF)	—	—	▼		
TCS SIGNAL 1 (ON/OFF)	—	—	▼		K
TCC SOLENOID (A)	—	X	▼		L
LINE PRES SOL (A)	—	X	▼		
I/C SOLENOID (A)	—	X	▼		
FR/B SOLENOID (A)	—	X	▼		M
D/C SOLENOID (A)	—	X	▼		
HLR/C SOL (A)	—	X	▼		N
ON OFF SOL (ON/OFF)	—	—	▼	LC/B solenoid	
TCC SOL MON (A)	—	—	▼		O
L/P SOL MON (A)	—	—	▼		
I/C SL MON (A)	—	—	▼		P
FR/B SOL MON (A)	—	—	▼		
D/C SOL MON (A)	—	—	▼		
HLR/C SOL MON (A)	—	—	▼		
ON OFF SOL MON (ON/OFF)	—	—	▼	LC/B solenoid	
P POSI IND (ON/OFF)	—	—	▼		

## TROUBLE DIAGNOSIS

### < SERVICE INFORMATION >

Monitored item (Unit)	Select Monitor Item			Remarks
	ECU INPUT SIGNALS	MAIN SIGNALS	SELECTION FROM MENU	
R POSI IND (ON/OFF)	—	—	▼	
N POSI IND (ON/OFF)	—	—	▼	
D POSI IND (ON/OFF)	—	—	▼	
4TH POSI IND (ON/OFF)	—	—	▼	
3RD POSI IND (ON/OFF)	—	—	▼	
2ND POSI IND (ON/OFF)	—	—	▼	
1ST POSI IND (ON/OFF)	—	—	▼	
MANU MODE IND (ON/OFF)	—	—	▼	
POWER M LAMP (ON/OFF)	—	—	▼	
F-SAFE IND/L (ON/OFF)	—	—	▼	
ATF WARN LAMP (ON/OFF)	—	—	▼	Not mounted but displayed
BACK-UP LAMP (ON/OFF)	—	—	▼	
STARTER RELAY (ON/OFF)	—	—	▼	
PNP SW3 MON (ON/OFF)	—	—	▼	
C/V CLB ID1	—	—	▼	
C/V CLB ID2	—	—	▼	
C/V CLB ID3	—	—	▼	
UNIT CLB ID1	—	—	▼	
UNIT CLB ID2	—	—	▼	
UNIT CLB ID3	—	—	▼	
TRGT GR RATIO	—	—	▼	
TRGT PRES TCC (kPa)	—	—	▼	
TRGT PRES L/P (kPa)	—	—	▼	
TRGT PRES I/C (kPa)	—	—	▼	
TRGT PRE FR/B (kPa)	—	—	▼	
TRGT PRES D/C (kPa)	—	—	▼	
TRG PRE HLR/C (kPa)	—	—	▼	
SHIFT PATTERN	—	—	▼	
DRV CST JUDGE	—	—	▼	
START RLY MON	—	—	▼	
NEXT GR POSI	—	—	▼	
SHIFT MODE	—	—	▼	
MANU GR POSI	—	—	▼	
VEHICLE SPEED (km/h)	—	X	▼	Vehicle speed recognized by the TCM.

# TROUBLE DIAGNOSIS

## < SERVICE INFORMATION >

Monitored item (Unit)	Select Monitor Item			Remarks
	ECU INPUT SIGNALS	MAIN SIGNALS	SELECTION FROM MENU	
Voltage (V)	—	—	▼	Displays the value measured by the voltage probe.
Frequency (Hz)	—	—	▼	The value measured by the pulse probe is displayed.
DUTY-HI (high) (%)	—	—	▼	
DUTY-LOW (low) (%)	—	—	▼	
PLS WIDTH-HI (ms)	—	—	▼	
PLS WIDTH-LOW (ms)	—	—	▼	

## DTC WORK SUPPORT MODE

### Display Items List

DTC work support item	Description	Check item
1ST GR FUNCTN P0731	Following items for "1st gear function" can be confirmed. <ul style="list-style-type: none"> <li>Self-diagnosis status (whether the diagnosis is being performed or not)</li> <li>Self-diagnostic results (OK or NG)</li> </ul>	<ul style="list-style-type: none"> <li>Input clutch solenoid valve</li> <li>Front brake solenoid valve</li> <li>Direct clutch solenoid valve</li> <li>High and low reverse clutch solenoid valve</li> <li>Each clutch</li> <li>Hydraulic control circuit</li> </ul>
2ND GR FUNCTN P0732	Following items for "2nd gear function" can be confirmed. <ul style="list-style-type: none"> <li>Self-diagnosis status (whether the diagnosis is being performed or not)</li> <li>Self-diagnostic results (OK or NG)</li> </ul>	
3RD GR FUNCTN P0733	Following items for "3rd gear function" can be confirmed. <ul style="list-style-type: none"> <li>Self-diagnosis status (whether the diagnosis is being performed or not)</li> <li>Self-diagnostic results (OK or NG)</li> </ul>	
4TH GR FUNCTN P0734	Following items for "4th gear function" can be confirmed. <ul style="list-style-type: none"> <li>Self-diagnosis status (whether the diagnosis is being performed or not)</li> <li>Self-diagnostic results (OK or NG)</li> </ul>	
5TH GR FUNCTN P0735	Following items for "5th gear function" can be confirmed. <ul style="list-style-type: none"> <li>Self-diagnosis status (whether the diagnosis is being performed or not)</li> <li>Self-diagnostic results (OK or NG)</li> </ul>	

## Diagnosis Procedure without CONSULT-III

INFOID:000000001327164

### OBD-II SELF-DIAGNOSTIC PROCEDURE (WITH GST)

Refer to [EC-125, "Generic Scan Tool \(GST\) Function"](#) (for VQ35DE) or [EC-704, "Generic Scan Tool \(GST\) Function"](#) (for VK45DE).

### OBD-II SELF-DIAGNOSTIC PROCEDURE (NO TOOLS)

Refer to [EC-71, "Malfunction Indicator Lamp \(MIL\)"](#) (for VQ35DE) or [EC-649, "Malfunction Indicator Lamp \(MIL\)"](#) (for VK45DE).

### TCM SELF-DIAGNOSTIC PROCEDURE (NO TOOLS)

#### Description

When the ignition switch is turned ON, the indicator lamp lights up for 2 seconds. As a method for locating the suspect circuit, when the self-diagnostics start signal is input, the memory for the malfunction location is output and the A/T CHECK indicator lamp flashes to display the corresponding DTC.

#### Diagnostic Procedure

# TROUBLE DIAGNOSIS

## < SERVICE INFORMATION >

### 1. CHECK A/T CHECK INDICATOR LAMP

1. Start the engine with selector lever in "P" position. Warm engine to normal operating temperature.
2. Turn ignition switch ON and OFF at least twice, then leave it in the OFF position.
3. Wait 10 seconds.
4. Turn ignition switch ON. (Do not start engine.)

Does A/T CHECK indicator lamp come on for about 2 seconds?

YES >> GO TO 2.

NO >> Go to [AT-170, "A/T Check Indicator Lamp Does Not Come On"](#).

### 2. JUDGEMENT PROCEDURE

1. Turn ignition switch OFF.
2. Keep pressing shift lock release button.
3. Move selector lever from "P" to "D" position.
4. Release accelerator pedal. (Set the closed throttle position signal ON.)
5. Depress brake pedal. (Stop lamp switch signal ON.)
6. Turn ignition switch ON. (Do not start engine.)
7. Wait 3 seconds.
8. Move the selector lever to the manual shift gate side. (Manual mode signal ON.)
9. Release brake pedal. (Stop lamp switch signal OFF.)
10. Move the selector lever to "D" position. (Manual mode signal OFF.)
11. Depress brake pedal. (Stop lamp switch signal ON.)
12. Release brake pedal. (Stop lamp switch signal OFF.)
13. Depress accelerator pedal fully and release it.

>> GO TO 3.

### 3. CHECK SELF-DIAGNOSIS CODE

Check A/T CHECK indicator lamp. Refer to "Judgement Self-diagnosis Code".

If the system does not go into self-diagnostics. Refer to [AT-102](#), [AT-155](#), [AT-164](#), [AT-165](#).

>> **DIAGNOSIS END**

Judgement Self-diagnosis Code

If there is a malfunction, the lamp lights up for the time corresponding to the suspect circuit.

No.	Malfunctioning item	No.	Malfunctioning item
1	Revolution sensor <a href="#">AT-108</a>	12	A/T interlock <a href="#">AT-139</a>
2	Direct clutch solenoid valve <a href="#">AT-147</a>	13	A/T 1st engine braking <a href="#">AT-141</a>
3	Torque converter clutch solenoid valve <a href="#">AT-124</a> , <a href="#">AT-126</a>	14	Start signal <a href="#">AT-97</a>
4	Line pressure solenoid valve <a href="#">AT-128</a>	15	Accelerator pedal position sensor <a href="#">AT-130</a>
5	Input clutch solenoid valve <a href="#">AT-143</a>	16	Engine speed signal <a href="#">AT-112</a>
6	Front brake solenoid valve <a href="#">AT-145</a>	17	CAN communication line <a href="#">AT-94</a>
7	Low coast brake solenoid valve <a href="#">AT-151</a> , <a href="#">AT-153</a>	18	1st gear function <a href="#">AT-114</a>
8	High and low reverse clutch solenoid valve <a href="#">AT-149</a>	19	2nd gear function <a href="#">AT-116</a>
9	PNP switch <a href="#">AT-102</a>	20	3rd gear function <a href="#">AT-118</a>
10	A/T fluid temperature sensor <a href="#">AT-132</a>	21	4th gear function <a href="#">AT-120</a>
11	Turbine revolution sensor <a href="#">AT-106</a>	22	5th gear function <a href="#">AT-122</a>

# TROUBLE DIAGNOSIS

## < SERVICE INFORMATION >

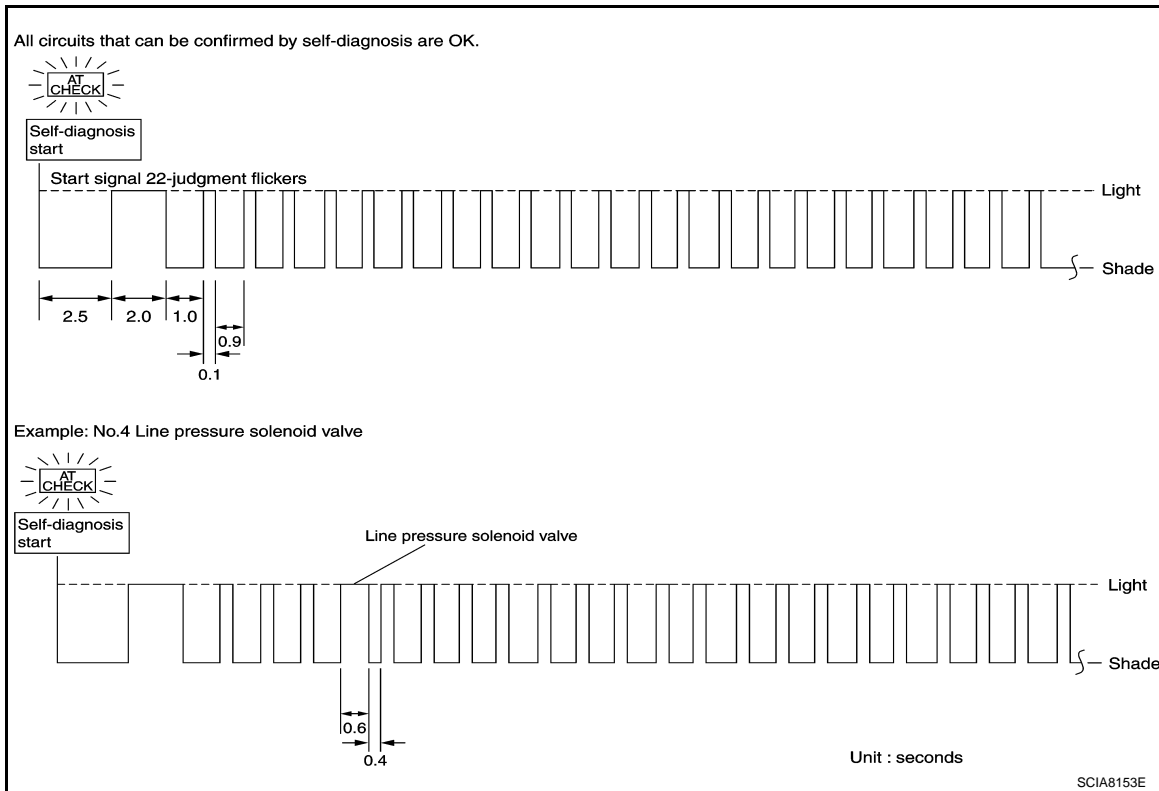

### Erase Self-diagnosis

- In order to make it easier to find the cause of hard-to-duplicate malfunctions, malfunction information is stored into the control unit as necessary during use by the user. This memory is not erased no matter how many times the ignition switch is turned ON and OFF.
- However, this information is erased by turning ignition switch "OFF" after performing self-diagnostics or by erasing the memory using the CONSULT-III.

A

B

AT

D

E

F

G

H

I

J

K

L

M

N

O

P

# DTC U1000 CAN COMMUNICATION LINE

< SERVICE INFORMATION >

## DTC U1000 CAN COMMUNICATION LINE

### Description

INFOID:000000001327165

CAN (Controller Area Network) is a serial communication line for real time application. It is an on-vehicle multiplex communication line with high data communication speed and excellent malfunction detection ability. Many electronic control units are equipped onto a vehicle, and each control unit shares information and links with other control units during operation (not independent). In CAN communication, control units are connected with 2 communication lines (CAN-H line, CAN-L line) allowing a high rate of information transmission with less wiring. Each control unit transmits/receives data but selectively reads required data only.

### On Board Diagnosis Logic

INFOID:000000001327166

Diagnostic trouble code "U1000 CAN COMM CIRCUIT" with CONSULT-III or 17th judgement flicker without CONSULT-III is detected when TCM cannot communicate to other control units.

### Possible Cause

INFOID:000000001327167

Harness or connectors  
(CAN communication line is open or shorted.)

### DTC Confirmation Procedure

INFOID:000000001327168

#### NOTE:

**If "DTC Confirmation Procedure" has been previously performed, always turn ignition switch OFF and wait at least 10 seconds before performing the next test.**

After the repair, perform the following procedure to confirm the malfunction is eliminated.

#### Ⓟ WITH CONSULT-III

1. Turn ignition switch ON.
2. Select "ECU INPUT SIGNALS" or "MAIN SIGNALS" in "DATA MONITOR" mode for "TRANSMISSION" with CONSULT-III.
3. Start engine and wait for at least 6 seconds.
4. If DTC is detected, go to [AT-96, "Diagnosis Procedure"](#).

#### Ⓞ WITH GST

Follow the procedure "WITH CONSULT-III".



# DTC U1000 CAN COMMUNICATION LINE

< SERVICE INFORMATION >

## Wiring Diagram - AT - CAN

INFOID:000000001327169

### AT-CAN-01

-  : DETECTABLE LINE FOR DTC
-  : NON-DETECTABLE LINE FOR DTC
-  : DATA LINE

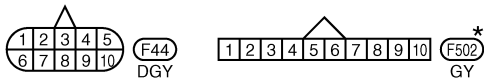
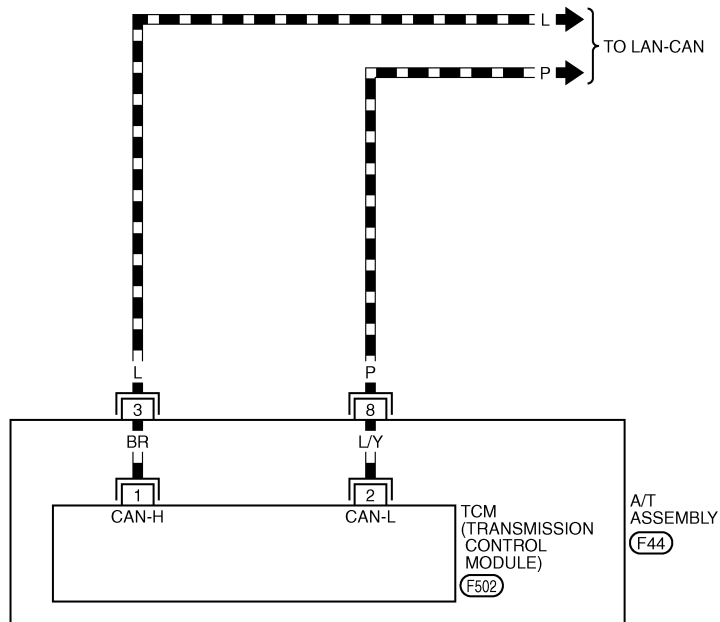

\*: THIS CONNECTOR IS NOT SHOWN IN "HARNESS LAYOUT", PG SECTION.

TCWM0496E

# DTC U1000 CAN COMMUNICATION LINE

## < SERVICE INFORMATION >

TCM terminals and data are reference value. Measured between each terminal and ground.

Terminal	Wire color	Item	Condition	Data (Approx.)
3	L	CAN-H	-	-
8	P	CAN-L	-	-

## Diagnosis Procedure

INFOID:000000001327170

### 1. CHECK CAN COMMUNICATION CIRCUIT

#### Ⓜ With CONSULT-III

1. Turn ignition switch ON and start engine.
2. Select "SELF-DIAG RESULTS" mode for "TRANSMISSION" with CONSULT-III.

Is the "U1000 CAN COMM CIRCUIT" indicated?

- YES >> Go to LAN section. Refer to [LAN-43, "CAN System Specification Chart"](#).  
NO >> **INSPECTION END**



# DTC P0615 START SIGNAL CIRCUIT

< SERVICE INFORMATION >

## DTC P0615 START SIGNAL CIRCUIT

### Description

INFOID:000000001327171

TCM prohibits cranking other than at "P" or "N" position.

### CONSULT-III Reference Value in Data Monitor Mode

INFOID:000000001327172

Item name	Condition	Display value
STARTER RELAY	Selector lever in "N" and "P" positions.	ON
	Selector lever in other positions.	OFF

### On Board Diagnosis Logic

INFOID:000000001327173

Diagnostic trouble code "P0615 STARTER RELAY/CIRC" with CONSULT-III or 14th judgement flicker without CONSULT-III is detected when starter relay is switched ON other than at "P" or "N" position. (Or when switched OFF at "P" or "N" position).

### Possible Cause

INFOID:000000001327174

- Harness or connectors  
(Starter relay and TCM circuit is open or shorted.)
- Starter relay circuit

### DTC Confirmation Procedure

INFOID:000000001327175

#### **CAUTION:**

**Always drive vehicle at a safe speed.**

#### **NOTE:**

**If "DTC Confirmation Procedure" has been previously performed, always turn ignition switch OFF and wait at least 10 seconds before performing the next test.**

After the repair, perform the following procedure to confirm the malfunction is eliminated.

#### Ⓟ WITH CONSULT-III

1. Turn ignition switch ON.
2. Select "SELECTION FROM MENU" in "DATA MONITOR" mode for "TRANSMISSION" with CONSULT-III and check monitor "STARTER RELAY" ON/OFF.
3. Start engine.
4. Drive vehicle for at least 2 consecutive seconds.
5. If DTC is detected, go to [AT-99. "Diagnosis Procedure"](#).





# DTC P0615 START SIGNAL CIRCUIT

< SERVICE INFORMATION >

## Wiring Diagram - AT - STSIG

INFOID:000000001327176

### AT-STSIG-01

-  : DETECTABLE LINE FOR DTC
-  : NON-DETECTABLE LINE FOR DTC
-  : WITH VK ENGINE
-  : WITH VQ ENGINE

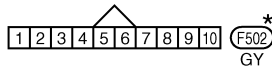
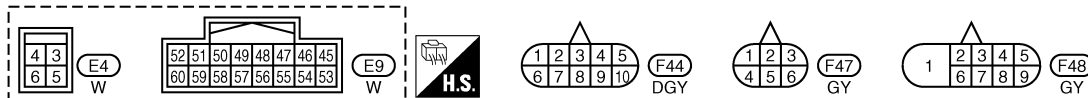
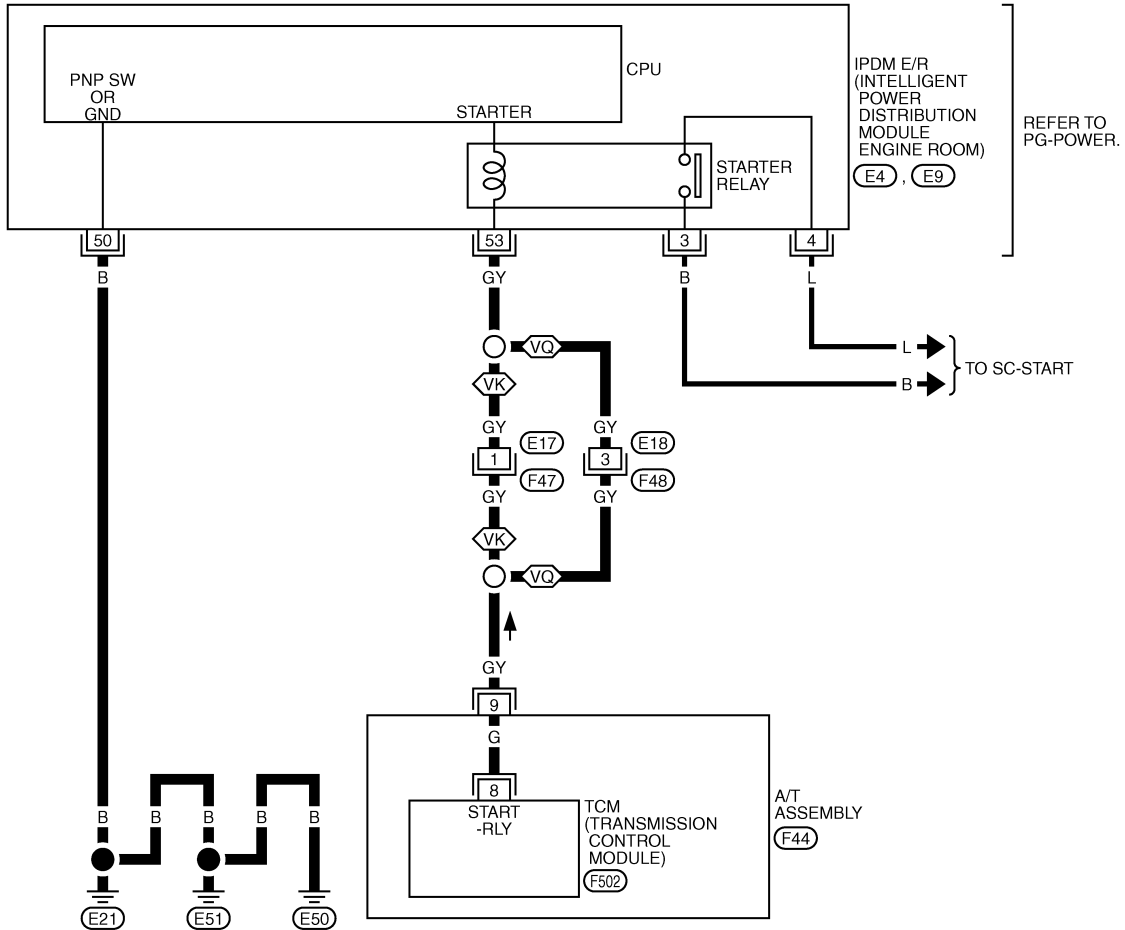

\*: THIS CONNECTOR IS NOT SHOWN IN "HARNESS LAYOUT", PG SECTION.

TCWM0247E

TCM terminals and data are reference value. Measured between each terminal and ground.

Terminal	Wire color	Item	Condition	Data (Approx.)
9	GY	Starter relay	 Selector lever in "N" and "P" positions.	Battery voltage
			Selector lever in other positions.	0 V

# DTC P0615 START SIGNAL CIRCUIT

< SERVICE INFORMATION >

## Diagnosis Procedure

INFOID:000000001327177

### 1. CHECK STARTER RELAY

#### With CONSULT-III

- Turn ignition switch ON.
- Select "SELECTION FROM MENU" in "DATA MONITOR" mode for "TRANSMISSION" with CONSULT-III and check monitor "STARTER RELAY" ON/OFF.

Item name	Condition	Display value
STARTER RELAY	Selector lever in "N" and "P" positions.	ON
	Selector lever in other positions.	OFF

#### Without CONSULT-III

- Turn ignition switch ON.
- Check voltage between the IPDM E/R connector and ground.

Name	Connector	Terminal	Shift position	Voltage (Approx.)
Starter relay	E9	53 - Ground	"N" and "P"	Battery voltage
			"R" and "D"	0 V

#### OK or NG

- OK >> GO TO 5.  
 NG >> GO TO 2.

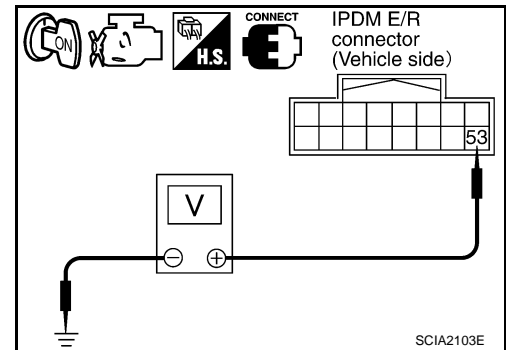

### 2. CHECK HARNESS BETWEEN A/T ASSEMBLY HARNESS CONNECTOR AND IPDM E/R CONNECTOR

- Turn ignition switch OFF.
- Disconnect A/T assembly harness connector and IPDM E/R connector.
- Check continuity between A/T assembly harness connector and IPDM E/R connector.

Item	Connector	Terminal	Continuity
A/T assembly harness connector	F44	9	Yes
IPDM E/R connector	E9	53	

- If OK, check harness for short to ground and short to power.
- Reinstall any part removed.

#### OK or NG

- OK >> GO TO 3.  
 NG >> Repair open circuit or short to ground or short to power in harness or connectors.

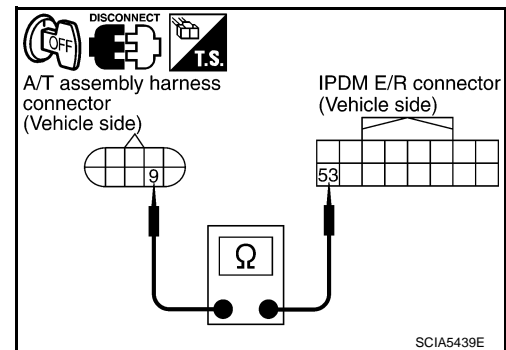

### 3. CHECK TERMINAL CORD ASSEMBLY

- Remove control valve with TCM. Refer to [AT-215, "Control Valve with TCM and A/T Fluid Temperature Sensor 2"](#).
- Disconnect A/T assembly harness connector and TCM connector.

## DTC P0615 START SIGNAL CIRCUIT

### < SERVICE INFORMATION >

3. Check continuity between A/T assembly harness connector terminal and TCM connector terminal.

Item	Connector	Terminal	Continuity
A/T assembly harness connector	F44	9	Yes
TCM connector	F502	8	

4. If OK, check harness for short to ground and short to power.  
 5. Reinstall any part removed.

#### OK or NG

- OK >> GO TO 4.  
 NG >> Replace open circuit or short to ground and short to power in harness or connectors.

### 4. DETECT MALFUNCTIONING ITEM

Check the following.

- Starter relay, Refer to [SC-8](#).
- IPDM E/R, Refer to [PG-17](#).

#### OK or NG

- OK >> Replace the control valve with TCM. Refer to [AT-215, "Control Valve with TCM and A/T Fluid Temperature Sensor 2"](#).  
 NG >> Repair or replace damaged parts.

### 5. CHECK DTC

Perform [AT-97, "DTC Confirmation Procedure"](#).

#### OK or NG

- OK >> **INSPECTION END**  
 NG >> GO TO 2.

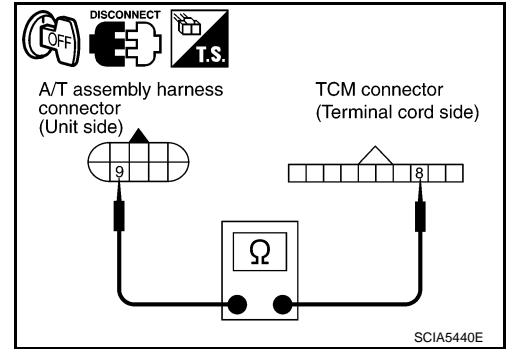

# DTC P0700 TCM

< SERVICE INFORMATION >

## DTC P0700 TCM

### Description

INFOID:000000001327178

The TCM consists of a microcomputer and connectors for signal input and output and for power supply. The TCM controls the A/T.

### On Board Diagnosis Logic

INFOID:000000001327179

Diagnostic trouble code "P0700 TCM" with CONSULT-III is detected when TCM is malfunctioning.

### Possible Cause

INFOID:000000001327180

TCM.

### DTC Confirmation Procedure

INFOID:000000001327181

#### NOTE:

**If "DTC Confirmation Procedure" has been previously performed, always turn ignition switch OFF and wait at least 10 seconds before performing the next test.**

After the repair, perform the following procedure to confirm the malfunction is eliminated.

#### Ⓜ WITH CONSULT-III

1. Turn ignition switch ON.
2. Select "ECU INPUT SIGNALS" or "MAIN SIGNALS" in "DATA MONITOR" mode for "TRANSMISSION" with CONSULT-III.
3. Touch "START".
4. Start engine.
5. Run engine for at least 2 consecutive seconds at idle speed.
6. If DTC is detected, go to [AT-101, "Diagnosis Procedure"](#).

#### Ⓜ WITH GST

Follow the procedure "WITH CONSULT-III".

### Diagnosis Procedure

INFOID:000000001327182

## 1. CHECK DTC

#### Ⓜ With CONSULT-III

1. Turn ignition switch ON.
2. Select "SELF DIAG RESULTS" mode for "TRANSMISSION" with CONSULT-III.
3. Touch "ERASE".
4. Turn ignition switch OFF and wait at least 10 seconds.
5. Perform [AT-101, "DTC Confirmation Procedure"](#).

Is the "P0700 TCM" displayed again?

- YES >> Replace the control valve with TCM. Refer to [AT-215, "Control Valve with TCM and A/T Fluid Temperature Sensor 2"](#).
- NO >> **INSPECTION END**

# DTC P0705 PARK/NEUTRAL POSITION SWITCH

< SERVICE INFORMATION >

## DTC P0705 PARK/NEUTRAL POSITION SWITCH

### Description

INFOID:000000001327183

- The PNP switch includes a transmission range switch.
- The transmission range switch detects the selector lever position and sends a signal to the TCM.

### CONSULT-III Reference Value in Data Monitor Mode

INFOID:000000001327184

Item name	Condition	Display value
SLCT LVR POSI	Selector lever in "N" and "P" positions.	N/P
	Selector lever in "R" position.	R
	Selector lever in "D" position.	D

### On Board Diagnosis Logic

INFOID:000000001327185

Diagnostic trouble code "P0705 PNP SW/CIRC" with CONSULT-III or 9th judgement flicker without CONSULT-III is detected under the following conditions.

- When TCM does not receive the correct voltage signal from the PNP switches 1, 2, 3 and 4 based on the gear position.
- When no other position but "P" position is detected from "N" position.

### Possible Cause

INFOID:000000001327186

- Harness or connectors  
(PNP switches 1, 2, 3 and 4 and TCM circuit is open or shorted.)
- PNP switches 1, 2, 3 and 4

### DTC Confirmation Procedure

INFOID:000000001327187

#### **CAUTION:**

**Always drive vehicle at a safe speed.**

#### **NOTE:**

**If "DTC Confirmation Procedure" has been previously performed, always turn ignition switch OFF and wait at least 10 seconds before performing the next test.**

After the repair, perform the following procedure to confirm the malfunction is eliminated.

#### WITH CONSULT-III

1. Turn ignition switch ON.
2. Select "ECU INPUT SIGNALS" or "MAIN SIGNALS" in "DATA MONITOR" mode for "TRANSMISSION" with CONSULT-III.
3. Touch "START".
4. Start engine.
5. Drive vehicle and maintain the following conditions for at least 2 consecutive seconds.  
**ACCELE POSI: More than 1.0/8**
6. If DTC is detected, go to [AT-103, "Diagnosis Procedure"](#).

#### WITH GST

Follow the procedure "WITH CONSULT-III".

# DTC P0705 PARK/NEUTRAL POSITION SWITCH

< SERVICE INFORMATION >

## Wiring Diagram - AT - PNP/SW

INFOID:000000001327188

### AT-PNP/SW-01

— : DETECTABLE LINE FOR DTC  
 - - - : NON-DETECTABLE LINE FOR DTC

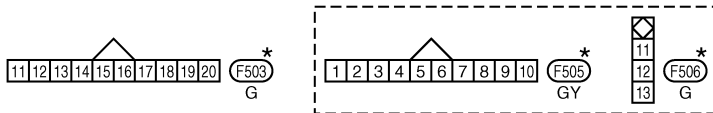
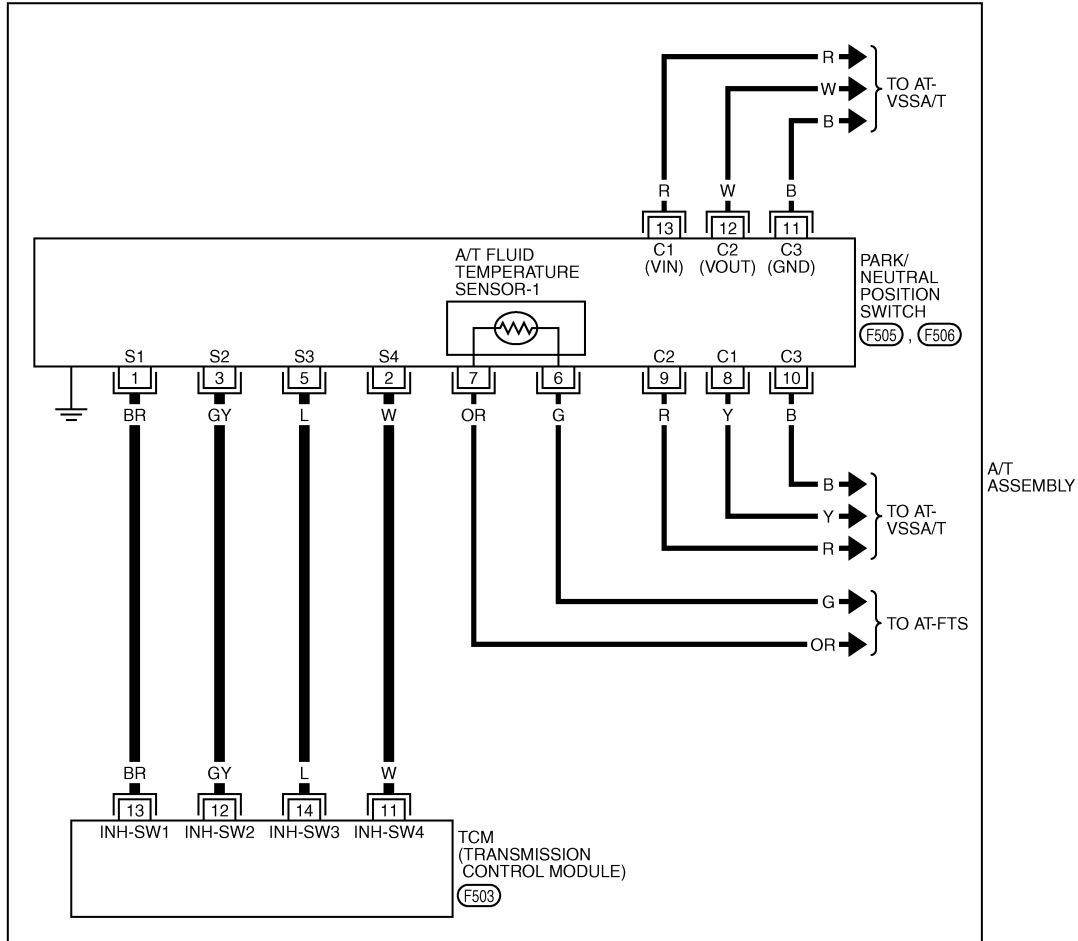

\*: THIS CONNECTOR IS NOT SHOWN IN "HARNESS LAYOUT", PG SECTION.

TCWM0248E

INFOID:000000001327189

## Diagnosis Procedure

### 1. CHECK PNP SW CIRCUIT

Ⓜ With CONSULT-III

1. Turn ignition switch ON.

# DTC P0705 PARK/NEUTRAL POSITION SWITCH

## < SERVICE INFORMATION >

2. Select "SELECTION FROM MENU" in "DATA MONITOR" mode for "TRANSMISSION" with CONSULT-III.
3. Check if correct selector lever position (N/P, R or D) is displayed as selector lever is moved into each position.

Item name	Condition	Display value
SLCT LVR POSI	Selector lever in "N" and "P" positions.	N/P
	Selector lever in "R" position.	R
	Selector lever in "D" position.	D

### OK or NG

- OK >> GO TO 5.  
 NG >> GO TO 2.

## 2.CHECK TCM POWER SUPPLY AND GROUND CIRCUIT

Check TCM power supply and ground circuit. Refer to [AT-160](#).

### OK or NG

- OK >> GO TO 3.  
 NG >> Repair or replace damaged parts.

## 3.DETECT MALFUNCTIONING ITEM

Check A/T assembly harness connector pin terminals for damage or loose connection with harness connector.

### OK or NG

- OK >> GO TO 4.  
 NG >> Repair or replace damaged parts.

## 4.CHECK SUB-HARNESS

1. Remove control valve with TCM. Refer to [AT-215, "Control Valve with TCM and A/T Fluid Temperature Sensor 2"](#).
2. Disconnect park/neutral position switch connector and TCM connector.
3. Check continuity between park/neutral position switch connector terminals and TCM connector terminals.

Item	Connector	Terminal	Continuity
Park/neutral position switch connector	F505	1	Yes
TCM connector	F503	13	
Park/neutral position switch connector	F505	2	Yes
TCM connector	F503	11	
Park/neutral position switch connector	F505	3	Yes
TCM connector	F503	12	
Park/neutral position switch connector	F505	5	Yes
TCM connector	F503	14	

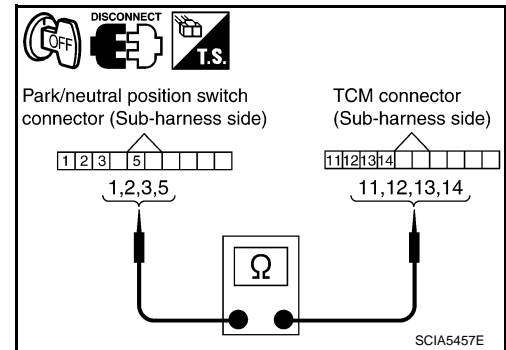

4. If OK, check harness for short to ground and short to power.
5. Reinstall any part removed.

### OK or NG

- OK >> Replace the control valve with TCM. Refer to [AT-215, "Control Valve with TCM and A/T Fluid Temperature Sensor 2"](#).  
 NG >> Replace open circuit or short to ground and short to power in harness or connectors.

## 5.CHECK DTC

Perform [AT-102, "DTC Confirmation Procedure"](#).

### OK or NG



# DTC P0705 PARK/NEUTRAL POSITION SWITCH

< SERVICE INFORMATION >

---

OK >> **INSPECTION END**

NG >> GO TO 2.

A

B

**AT**

D

E

F

G

H

I

J

K

L

M

N

O

P

# DTC P0717 TURBINE REVOLUTION SENSOR

< SERVICE INFORMATION >

## DTC P0717 TURBINE REVOLUTION SENSOR

### Description

INFOID:000000001327190

The turbine revolution sensor detects input shaft rpm (revolutions per minute). It is located on the input side of the automatic transmission. Monitors revolution of sensor 1 and sensor 2 for non-standard conditions.

### CONSULT-III Reference Value in Data Monitor Mode

INFOID:000000001327191

Item name	Condition	Display value
TURBINE REV	During driving (lock-up ON)	Approximately matches the engine speed.

### On Board Diagnosis Logic

INFOID:000000001327192

Diagnostic trouble code "P0717 TURBINE REV S/CIRC" with CONSULT-III or 11th judgement flicker without CONSULT-III is detected under the following conditions.

- When TCM does not receive the proper voltage signal from the sensor.
- When TCM detects an irregularity only at position of 4th gear for turbine revolution sensor 2.

### Possible Cause

INFOID:000000001327193

- Harness or connectors  
(Sensor circuit is open or shorted.)
- Turbine revolution sensor 1 and/or 2

### DTC Confirmation Procedure

INFOID:000000001327194

#### **CAUTION:**

- **Always drive vehicle at a safe speed.**
- **Be careful not to rev engine into the red zone on the tachometer.**

#### **NOTE:**

If "DTC Confirmation Procedure" has been previously performed, always turn ignition switch OFF and wait at least 10 seconds before performing the next test.

After the repair, perform the following procedure to confirm the malfunction is eliminated.

#### Ⓟ WITH CONSULT-III

1. Turn ignition switch ON.
2. Select "SELECTION FROM MENU" in "DATA MONITOR" mode for "TRANSMISSION" with CONSULT-III and check monitor "VHCL/S SE-A/T", "ENGINE SPEED", "ACCELE POSI", "SLCT LVR POSI" and "GEAR".
3. Touch "START".
4. Start engine and maintain the following conditions for at least 5 consecutive seconds.  
**VHCL/S SE-A/T: 40 km/h (25 MPH) or more**  
**ENGINE SPEED: 1,500 rpm or more**  
**ACCELE POSI: More than 0.5/8**  
**SLCT LVR POSI: "D" position**  
**GEAR (Turbine revolution sensor 1): "4" or "5" position**  
**GEAR (Turbine revolution sensor 2): All positions**  
**Driving location: Driving the vehicle uphill (increased engine load) will help maintain the driving conditions required for this test.**
5. If DTC is detected, go to [AT-106, "Diagnosis Procedure"](#).

#### Ⓟ WITH GST

Follow the procedure "WITH CONSULT-III".

### Diagnosis Procedure

INFOID:000000001327195

#### 1. CHECK INPUT SIGNAL

##### Ⓟ With CONSULT-III

1. Start engine.
2. Select "ECU INPUT SIGNALS" in "DATA MONITOR" mode for "TRANSMISSION" with CONSULT-III.

# DTC P0717 TURBINE REVOLUTION SENSOR

## < SERVICE INFORMATION >

3. Vehicle start and read out the value of "TURBINE REV".

Item name	Condition	Display value (rpm)
TURBINE REV	During driving (lock-up ON)	Approximately matches the engine speed.

### OK or NG

- OK >> GO TO 4.
- NG >> GO TO 2.

## 2.CHECK TCM POWER SUPPLY AND GROUND CIRCUIT

Check TCM power supply and ground circuit. Refer to [AT-160](#).

### OK or NG

- OK >> GO TO 3.
- NG >> Repair or replace damaged parts.

## 3.DETECT MALFUNCTIONING ITEM

Check A/T assembly harness connector pin terminals for damage or loose connection with harness connector.

### OK or NG

- OK >> Replace the control valve with TCM. Refer to [AT-215, "Control Valve with TCM and A/T Fluid Temperature Sensor 2"](#).
- NG >> Repair or replace damaged parts.

## 4.CHECK DTC

Perform [AT-106, "DTC Confirmation Procedure"](#).

### OK or NG

- OK >> **INSPECTION END**
- NG >> GO TO 2.

A  
B  
AT  
D  
E  
F  
G  
H  
I  
J  
K  
L  
M  
N  
O  
P

# DTC P0720 VEHICLE SPEED SENSOR A/T (REVOLUTION SENSOR)

< SERVICE INFORMATION >

## DTC P0720 VEHICLE SPEED SENSOR A/T (REVOLUTION SENSOR)

### Description

INFOID:000000001327196

The revolution sensor detects the revolution of the parking gear and emits a pulse signal. The pulse signal is sent to the TCM which converts it into vehicle speed.

### CONSULT-III Reference Value in Data Monitor Mode

INFOID:000000001327197

Item name	Condition	Display value
VHCL/S SE-A/T	During driving	Approximately matches the speedometer reading.

### On Board Diagnosis Logic

INFOID:000000001327198

Diagnostic trouble code "P0720 VEH SPD SEN/CIR AT" with CONSULT-III or 1st judgement flicker without CONSULT-III is detected under the following conditions.

- When TCM does not receive the proper voltage signal from the sensor.
- After ignition switch is turned ON, irregular signal input from vehicle speed sensor MTR before the vehicle starts moving.

### Possible Cause

INFOID:000000001327199

- Harness or connectors  
(Sensor circuit is open or shorted.)
- Revolution sensor
- Vehicle speed sensor MTR

### DTC Confirmation Procedure

INFOID:000000001327200

#### **CAUTION:**

- **Always drive vehicle at a safe speed.**
- **Be careful not to rev engine into the red zone on the tachometer.**

#### **NOTE:**

If "DTC Confirmation Procedure" has been previously performed, always turn ignition switch OFF and wait at least 10 seconds before performing the next test.

After the repair, perform the following procedure to confirm the malfunction is eliminated.

#### Ⓟ WITH CONSULT-III

1. Turn ignition switch ON.
2. Select "ECU INPUT SIGNALS" in "DATA MONITOR" mode for "TRANSMISSION" with CONSULT-III.
3. Touch "START".
4. Drive vehicle and check for an increase of "VHCL/S SE-A/T" value in response to "VHCL/S SE-MTR" value.  
If the check result is NG, go to [AT-110, "Diagnosis Procedure"](#).  
If the check result is OK, go to following step.
5. Select "SELECTION FROM MENU" in "DATA MONITOR" mode for "TRANSMISSION" with CONSULT-III and check monitor "VHCL/S SE-A/T", "ACCELE POSI", "ENGINE SPEED" and "SLCT LVR POSI".
6. Start engine and maintain the following conditions for at least 5 consecutive seconds.  
**VHCL/S SE-A/T: 30 km/h (19 MPH) or more**  
**ACCELE POSI: More than 1.0/8**  
**SLCT LVR POSI: "D" position**  
**Driving location: Driving the vehicle uphill (increased engine load) will help maintain the driving conditions required for this test.**  
If the check result is NG, go to [AT-110, "Diagnosis Procedure"](#).  
If the check result is OK, go to following step.
7. Maintain the following conditions for at least 5 consecutive seconds.  
**ENGINE SPEED: 3,500 rpm or more**  
**ACCELE POSI: More than 1.0/8**  
**SLCT LVR POSI: "D" position**  
**Driving location: Driving the vehicle uphill (increased engine load) will help maintain the driving conditions required for this test.**

# DTC P0720 VEHICLE SPEED SENSOR A/T (REVOLUTION SENSOR)

< SERVICE INFORMATION >

8. If DTC is detected, go to [AT-110. "Diagnosis Procedure"](#).

WITH GST

Follow the procedure "WITH CONSULT-III".

## Wiring Diagram - AT - VSSA/T

INFOID:000000001327201

### AT-VSSA/T-01

**—** : DETECTABLE LINE FOR DTC  
**—** : NON-DETECTABLE LINE FOR DTC

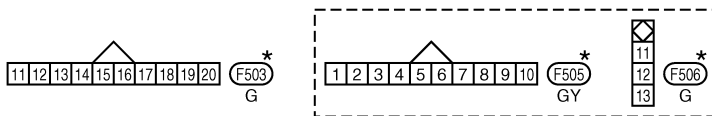
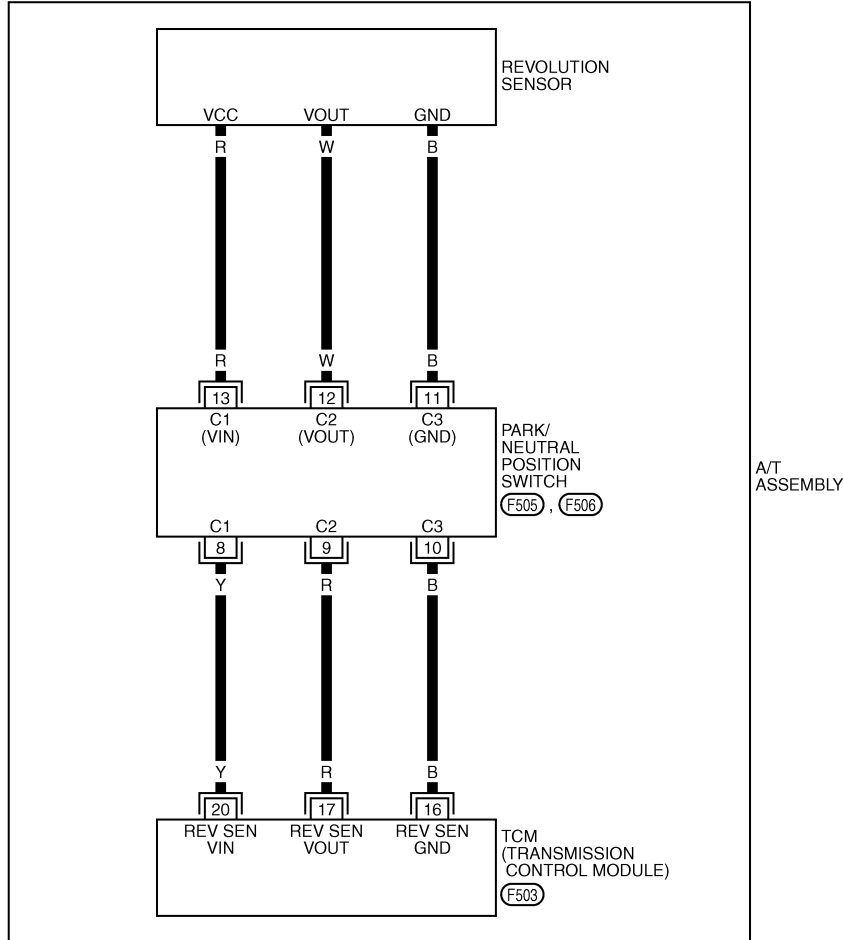

\*: THIS CONNECTOR IS NOT SHOWN IN "HARNESS LAYOUT", PG SECTION.

TCWM0249E

# DTC P0720 VEHICLE SPEED SENSOR A/T (REVOLUTION SENSOR)

< SERVICE INFORMATION >

## Diagnosis Procedure

INFOID:000000001327202

### 1. CHECK INPUT SIGNAL

#### With CONSULT-III

1. Turn ignition switch ON.
2. Select "ECU INPUT SIGNALS" in "DATA MONITOR" mode for "TRANSMISSION" with CONSULT-III.
3. Start engine.
4. Read out the value of "VHCL/S SE-A/T" while driving.  
Check the value changes according to driving speed.

Item name	Condition	Display value
VHCL/S SE-A/T	During driving	Approximately matches the speedometer reading.

#### OK or NG

- OK >> GO TO 6.  
NG >> GO TO 2.

### 2. CHECK TCM POWER SUPPLY AND GROUND CIRCUIT

Check TCM power supply and ground circuit. Refer to [AT-160](#).

#### OK or NG

- OK >> GO TO 3.  
NG >> Repair or replace damaged parts.

### 3. DETECT MALFUNCTIONING ITEM

Check A/T assembly harness connector pin terminals for damage or loose connection with harness connector.

#### OK or NG

- OK >> GO TO 4.  
NG >> Repair or replace damaged parts.

### 4. CHECK SUB-HARNESS

1. Remove control valve with TCM. Refer to [AT-215, "Control Valve with TCM and A/T Fluid Temperature Sensor 2"](#).
2. Disconnect park/neutral position switch connector and TCM connector.
3. Check continuity between park/neutral position switch connector terminals and TCM connector terminals.

Item	Connector	Terminal	Continuity
Park/neutral position switch connector	F505	8	Yes
TCM connector	F503	20	
Park/neutral position switch connector	F505	9	Yes
TCM connector	F503	17	
Park/neutral position switch connector	F505	10	Yes
TCM connector	F503	16	

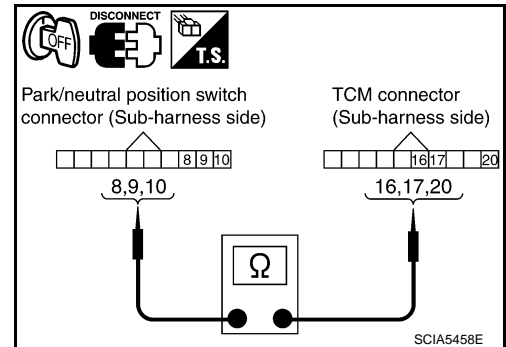

4. If OK, check harness for short to ground and short to power.
5. Reinstall any part removed.

#### OK or NG

- OK >> GO TO 5.  
NG >> Replace open circuit or short to ground and short to power in harness or connectors.

### 5. REPLACE THE REVOLUTION SENSOR AND CHECK DTC

1. Replace the revolution sensor. Refer to [AT-233, "Revolution Sensor Component \(2WD Models Only\)"](#) (2WD models) or [AT-267, "Disassembly"](#), [AT-249, "Component"](#) (AWD models).

# DTC P0720 VEHICLE SPEED SENSOR A/T (REVOLUTION SENSOR)

< SERVICE INFORMATION >

---

2. Perform [AT-108. "DTC Confirmation Procedure"](#).

OK or NG

OK >> **INSPECTION END**

NG >> Replace the control valve with TCM. Refer to [AT-215. "Control Valve with TCM and A/T Fluid Temperature Sensor 2"](#).

## 6.CHECK DTC

---

Perform [AT-108. "DTC Confirmation Procedure"](#).

OK or NG

OK >> **INSPECTION END**

NG >> GO TO 2.

A

B

AT

D

E

F

G

H

I

J

K

L

M

N

O

P

# DTC P0725 ENGINE SPEED SIGNAL

< SERVICE INFORMATION >

## DTC P0725 ENGINE SPEED SIGNAL

### Description

INFOID:000000001327203

The engine speed signal is sent from the ECM to the TCM with CAN communication.

### CONSULT-III Reference Value in Data Monitor Mode

INFOID:000000001327204

Item name	Condition	Display value
ENGINE SPEED	Engine running	Closely matches the tachometer reading.

### On Board Diagnosis Logic

INFOID:000000001327205

Diagnostic trouble code "P0725 ENGINE SPEED SIG" with CONSULT-III or 16th judgement flicker without CONSULT-III is detected when TCM does not receive the ignition signal from ECM during engine cranking or running.

### Possible Cause

INFOID:000000001327206

Harness or connectors  
(ECM to TCM circuit is open or shorted.)

### DTC Confirmation Procedure

INFOID:000000001327207

#### **CAUTION:**

**Always drive vehicle at a safe speed.**

#### **NOTE:**

**If "DTC Confirmation Procedure" has been previously performed, always turn ignition switch OFF and wait at least 10 seconds before performing the next test.**

After the repair, perform the following procedure to confirm the malfunction is eliminated.

#### WITH CONSULT-III

1. Turn ignition switch ON.
2. Select "SELECTION FROM MENU" in "DATA MONITOR" mode for "TRANSMISSION" with CONSULT-III and check monitor "VHCL/S SE-A/T", "ACCELE POSI" and "SLCT LVR POSI".
3. Touch "START".
4. Start engine and maintain the following conditions for at least 10 consecutive seconds.  
**VHCL/S SE-A/T: 10 km/h (6 MPH) or more**  
**ACCELE POSI: More than 1.0/8**  
**SLCT LVR POSI: "D" position**
5. If DTC is detected, go to [AT-112. "Diagnosis Procedure"](#).

### Diagnosis Procedure

INFOID:000000001327208

#### 1. CHECK CAN COMMUNICATION LINE

##### With CONSULT-III

- Perform the self-diagnosis.

##### Without CONSULT-III

- Perform the self-diagnosis. Refer to [AT-91. "Diagnosis Procedure without CONSULT-III"](#).

Is a malfunction in the CAN communication indicated in the results?

- YES >> Check CAN communication line. Refer to [AT-94](#).
- NO >> GO TO 2.

#### 2. CHECK DTC WITH TCM

##### With CONSULT-III

1. Start engine.
2. Select "ECU INPUT SIGNALS" in "DATA MONITOR" mode for "TRANSMISSION" with CONSULT-III.



# DTC P0725 ENGINE SPEED SIGNAL

## < SERVICE INFORMATION >

3. While monitoring engine speed, check for engine speed change corresponding to wide-open throttle position signal.

Item name	Condition	Display value
ENGINE SPEED	Engine running	Closely matches the tachometer reading.

### OK or NG

OK >> GO TO 3.

NG >> Check the ignition signal circuit. Refer to [EC-569](#) (for VQ35DE) or [EC-1166](#) (for VK45DE)

### **3.**CHECK DTC

Perform [AT-112. "DTC Confirmation Procedure"](#).

### OK or NG

OK >> **INSPECTION END**

NG >> GO TO 4.

### **4.**CHECK TCM POWER SUPPLY AND GROUND CIRCUIT

Check TCM power supply and ground circuit. Refer to [AT-160](#).

### OK or NG

OK >> GO TO 5.

NG >> Repair or replace damaged parts.

### **5.**DETECT MALFUNCTIONING ITEM

Check A/T assembly harness connector pin terminals for damage or loose connection with harness connector.

### OK or NG

OK >> Replace the control valve with TCM. Refer to [AT-215. "Control Valve with TCM and A/T Fluid Temperature Sensor 2"](#).

NG >> Repair or replace damaged parts.

# DTC P0731 A/T 1ST GEAR FUNCTION

< SERVICE INFORMATION >

## DTC P0731 A/T 1ST GEAR FUNCTION

### Description

INFOID:000000001375112

This malfunction is detected when the A/T does not shift into 1st gear position as instructed by TCM. This is not only caused by electrical malfunction (circuits open or shorted) but also by mechanical malfunction such as control valve sticking, improper solenoid valve operation.

### On Board Diagnosis Logic

INFOID:000000001375113

Diagnostic trouble code "P0731 A/T 1ST GR FNCTN" with CONSULT-III or 18th judgment flicker without CONSULT-III is detected when TCM detects any inconsistency in the actual gear ratio.

### Possible Cause

INFOID:000000001375114

- Harness or connectors  
(Solenoid circuits are open or shorted.)
- Input clutch solenoid valve
- Front brake solenoid valve
- Direct clutch solenoid valve
- High and low reverse clutch solenoid valve
- Each clutch
- Hydraulic control circuit

### DTC Confirmation Procedure

INFOID:000000001375115

#### **CAUTION:**

**Always drive vehicle at a safe speed.**

#### **NOTE:**

**If "DTC Confirmation Procedure" has been previously performed, always turn ignition switch OFF and wait at least 10 seconds before performing the next test.**

After the repair, perform the following procedure to confirm the malfunction is eliminated.

#### WITH CONSULT-III

1. Start the engine and select "DATA MONITOR" mode for "TRANSMISSION" with CONSULT-III.
2. Make sure that "ATF TEMP 1" is within the following range.  
**ATF TEMP 1: 20°C – 140°C**  
If out of range, drive vehicle to warm ATF or stop engine to cool ATF.
3. Select "1ST GR FNCTN P0731" of "DTC WORK SUPPORT" mode for "TRANSMISSION" with CONSULT-III.
4. Drive vehicle and maintain the following conditions.  
**VEHICLE SPEED: 10 km/h (6 MPH) or more**  
**ACCELE POSI: 0.6/8 or more**  
**ENGINE SPEED: TURBINE REV – 50 rpm or more**  
**TURBINE REV: 300 rpm or more**  
**GEAR: "1" position**  
**MANU MODE SW: ON**
5. Keep the current driving status for at least 5 consecutive seconds if CONSULT-III screen changes from "OUT OF CONDITION" to "TESTING".  
**CAUTION:**  
**If "TESTING" does not appear on CONSULT-III for a long time, select "SELF-DIAG RESULTS". In case a 1st trip DTC other than P0731 is shown, refer to "[AT-84, "CONSULT-III Function \(TRANSMISSION\)"](#)".**  
If "COMPLETED RESULT NG" is detected, go to [AT-115, "Diagnosis Procedure"](#).  
If "STOP VEHICLE" is detected, go to the following step.
6. Stop vehicle.
7. Drive vehicle in "D" position allowing it to shift from 1st to 5th gear and check shift timing and shift shock.
  - Touch "OK" to complete the inspection when normally shifted from the 1st to 5th gear.
  - Touch "NG" when an unusual shift shock, etc. occurs in spite of shifting from the 1st to 5th gear. Go to [AT-49, "Inspections Before Trouble Diagnosis"](#).
  - Perform [AT-84, "CONSULT-III Function \(TRANSMISSION\)"](#) when not shifted from the 1st to 5th gear. (Neither "OK" nor "NG" are indicated.)

# DTC P0731 A/T 1ST GEAR FUNCTION

< SERVICE INFORMATION >

## Diagnosis Procedure

INFOID:000000001375116

### 1. CHECK CAN COMMUNICATION LINE

#### With CONSULT-III

- Perform self-diagnosis.

#### Without CONSULT-III

- Perform self-diagnosis. Refer to [AT-91, "Diagnosis Procedure without CONSULT-III"](#).

Is a malfunction in the CAN communication indicated in the results?

YES >> Check CAN communication line. Refer to [AT-124](#).

NO >> GO TO 2.

### 2. CHECK TCM POWER SUPPLY AND GROUND CIRCUIT

Check TCM power supply and ground circuit. Refer to [AT-126](#).

OK or NG

OK >> GO TO 3.

NG >> Repair or replace damaged parts.

### 3. DETECT MALFUNCTION ITEM

Check A/T assembly harness connector pin terminals for damage or loose connection with harness connector.

OK or NG

OK >> GO TO 4.

NG >> Repair or replace damaged parts.

### 4. REPLACE CONTROL VALVE WITH TCM

1. Replace control valve with TCM. Refer to [AT-215, "Control Valve with TCM and A/T Fluid Temperature Sensor 2"](#).

2. Perform [AT-114, "DTC Confirmation Procedure"](#).

OK or NG

OK >> **INSPECTION END**

NG >> Confirm malfunction phenomena by "ROAD TEST" to repair malfunctioning part. Refer to [AT-49, "Inspections Before Trouble Diagnosis"](#).

A

B

AT

D

E

F

G

H

I

J

K

L

M

N

O

P

# DTC P0732 A/T 2ND GEAR FUNCTION

< SERVICE INFORMATION >

## DTC P0732 A/T 2ND GEAR FUNCTION

### Description

INFOID:000000001375117

This malfunction is detected when the A/T does not shift into 2nd gear position as instructed by TCM. This is not only caused by electrical malfunction (circuits open or shorted) but also by mechanical malfunction such as control valve sticking, improper solenoid valve operation.

### On Board Diagnosis Logic

INFOID:000000001375118

Diagnostic trouble code "P0732 A/T 2ND GR FNCTN" with CONSULT-III or 19th judgment flicker without CONSULT-III is detected when TCM detects any inconsistency in the actual gear ratio.

### Possible Cause

INFOID:000000001375119

- Harness or connectors  
(Solenoid circuits are open or shorted.)
- Input clutch solenoid valve
- Front brake solenoid valve
- Direct clutch solenoid valve
- High and low reverse clutch solenoid valve
- Each clutch
- Hydraulic control circuit

### DTC Confirmation Procedure

INFOID:000000001375120

#### **CAUTION:**

**Always drive vehicle at a safe speed.**

#### **NOTE:**

**If "DTC Confirmation Procedure" has been previously performed, always turn ignition switch OFF and wait at least 10 seconds before performing the next test.**

After the repair, perform the following procedure to confirm the malfunction is eliminated.

#### WITH CONSULT-III

1. Start the engine and select "DATA MONITOR" mode for "TRANSMISSION" with CONSULT-III.
2. Make sure that "ATF TEMP 1" is within the following range.  
**ATF TEMP 1: 20°C – 140°C**  
If out of range, drive vehicle to warm ATF or stop engine to cool ATF.
3. Select "2ND GR FNCTN P0732" of "DTC WORK SUPPORT" mode for "TRANSMISSION" with CONSULT-III.
4. Drive vehicle and maintain the following conditions.  
**VEHICLE SPEED: 10 km/h (6 MPH) or more**  
**ACCELE POSI: 0.6/8 or more**  
**ENGINE SPEED: TURBINE REV – 50 rpm or more**  
**TURBINE REV: 300 rpm or more**  
**GEAR: "2" position**  
**MANU MODE SW: ON**
5. Keep the current driving status for at least 5 consecutive seconds if CONSULT-III screen changes from "OUT OF CONDITION" to "TESTING".  
**CAUTION:**  
**If "TESTING" does not appear on CONSULT-III for a long time, select "SELF-DIAG RESULTS". In case a 1st trip DTC other than P0732 is shown, refer to "[AT-84, "CONSULT-III Function \(TRANSMISSION\)"](#)".**  
If "COMPLETED RESULT NG" is detected, go to [AT-117, "Diagnosis Procedure"](#).  
If "STOP VEHICLE" is detected, go to the following step.
6. Stop vehicle.
7. Drive vehicle in "D" position allowing it to shift from 1st to 5th gear and check shift timing and shift shock.
  - Touch "OK" to complete the inspection when normally shifted from the 1st to 5th gear.
  - Touch "NG" when an unusual shift shock, etc. occurs in spite of shifting from the 1st to 5th gear. Go to [AT-49, "Inspections Before Trouble Diagnosis"](#).
  - Perform [AT-84, "CONSULT-III Function \(TRANSMISSION\)"](#) when not shifted from the 1st to 5th gear. (Neither "OK" nor "NG" are indicated.)

# DTC P0732 A/T 2ND GEAR FUNCTION

< SERVICE INFORMATION >

## Diagnosis Procedure

INFOID:000000001375121

### 1. CHECK CAN COMMUNICATION LINE

#### With CONSULT-III

- Perform self-diagnosis.

#### Without CONSULT-III

- Perform self-diagnosis. Refer to [AT-91, "Diagnosis Procedure without CONSULT-III"](#).

Is a malfunction in the CAN communication indicated in the results?

YES >> Check CAN communication line. Refer to [AT-94](#).

NO >> GO TO 2.

### 2. CHECK TCM POWER SUPPLY AND GROUND CIRCUIT

Check TCM power supply and ground circuit. Refer to [AT-160](#).

OK or NG

OK >> GO TO 3.

NG >> Repair or replace damaged parts.

### 3. DETECT MALFUNCTION ITEM

Check A/T assembly harness connector pin terminals for damage or loose connection with harness connector.

OK or NG

OK >> GO TO 4.

NG >> Repair or replace damaged parts.

### 4. REPLACE CONTROL VALVE WITH TCM

1. Replace control valve with TCM. Refer to [AT-215, "Control Valve with TCM and A/T Fluid Temperature Sensor 2"](#).

2. Perform [AT-116, "DTC Confirmation Procedure"](#).

OK or NG

OK >> **INSPECTION END**

NG >> Confirm malfunction phenomena by "ROAD TEST" to repair malfunctioning part. Refer to [AT-49, "Inspections Before Trouble Diagnosis"](#).

A  
B  
AT  
D  
E  
F  
G  
H  
I  
J  
K  
L  
M  
N  
O  
P

# DTC P0733 A/T 3RD GEAR FUNCTION

< SERVICE INFORMATION >

## DTC P0733 A/T 3RD GEAR FUNCTION

### Description

INFOID:000000001375122

This malfunction is detected when the A/T does not shift into 3rd gear position as instructed by TCM. This is not only caused by electrical malfunction (circuits open or shorted) but also by mechanical malfunction such as control valve sticking, improper solenoid valve operation.

### On Board Diagnosis Logic

INFOID:000000001375123

Diagnostic trouble code "P0733 A/T 3RD GR FNCTN" with CONSULT-III or 20th judgment flicker without CONSULT-III is detected when TCM detects any inconsistency in the actual gear ratio.

### Possible Cause

INFOID:000000001375124

- Harness or connectors  
(Solenoid circuits are open or shorted.)
- Input clutch solenoid valve
- Front brake solenoid valve
- Direct clutch solenoid valve
- High and low reverse clutch solenoid valve
- Each clutch
- Hydraulic control circuit

### DTC Confirmation Procedure

INFOID:000000001375125

#### **CAUTION:**

**Always drive vehicle at a safe speed.**

#### **NOTE:**

**If "DTC Confirmation Procedure" has been previously performed, always turn ignition switch OFF and wait at least 10 seconds before performing the next test.**

After the repair, perform the following procedure to confirm the malfunction is eliminated.

#### WITH CONSULT-III

1. Start the engine and select "DATA MONITOR" mode for "TRANSMISSION" with CONSULT-III.
2. Make sure that "ATF TEMP 1" is within the following range.  
**ATF TEMP 1: 20°C – 140°C**  
If out of range, drive vehicle to warm ATF or stop engine to cool ATF.
3. Select "3RD GR FNCTN P0733" of "DTC WORK SUPPORT" mode for "TRANSMISSION" with CONSULT-III.
4. Drive vehicle and maintain the following conditions.  
**VEHICLE SPEED: 10 km/h (6 MPH) or more**  
**ACCELE POSI: 0.6/8 or more**  
**ENGINE SPEED: TURBINE REV – 50 rpm or more**  
**TURBINE REV: 300 rpm or more**  
**GEAR: "3" position**  
**MANU MODE SW: ON**
5. Keep the current driving status for at least 5 consecutive seconds if CONSULT-III screen changes from "OUT OF CONDITION" to "TESTING".  
**CAUTION:**  
**If "TESTING" does not appear on CONSULT-III for a long time, select "SELF-DIAG RESULTS". In case a 1st trip DTC other than P0732 is shown, refer to "[AT-84, "CONSULT-III Function \(TRANSMISSION\)"](#)".**  
If "COMPLETED RESULT NG" is detected, go to [AT-119, "Diagnosis Procedure"](#).  
If "STOP VEHICLE" is detected, go to the following step.
6. Stop vehicle.
7. Drive vehicle in "D" position allowing it to shift from 1st to 5th gear and check shift timing and shift shock.
  - Touch "OK" to complete the inspection when normally shifted from the 1st to 5th gear.
  - Touch "NG" when an unusual shift shock, etc. occurs in spite of shifting from the 1st to 5th gear. Go to [AT-49, "Inspections Before Trouble Diagnosis"](#).
  - Perform [AT-84, "CONSULT-III Function \(TRANSMISSION\)"](#) when not shifted from the 1st to 5th gear. (Neither "OK" nor "NG" are indicated.)

# DTC P0733 A/T 3RD GEAR FUNCTION

< SERVICE INFORMATION >

## Diagnosis Procedure

INFOID:000000001375126

### 1. CHECK CAN COMMUNICATION LINE

#### With CONSULT-III

- Perform self-diagnosis.

#### Without CONSULT-III

- Perform self-diagnosis. Refer to [AT-91, "Diagnosis Procedure without CONSULT-III"](#).

Is a malfunction in the CAN communication indicated in the results?

YES >> Check CAN communication line. Refer to [AT-94](#).

NO >> GO TO 2.

### 2. CHECK TCM POWER SUPPLY AND GROUND CIRCUIT

Check TCM power supply and ground circuit. Refer to [AT-160](#).

OK or NG

OK >> GO TO 3.

NG >> Repair or replace damaged parts.

### 3. DETECT MALFUNCTION ITEM

Check A/T assembly harness connector pin terminals for damage or loose connection with harness connector.

OK or NG

OK >> GO TO 4.

NG >> Repair or replace damaged parts.

### 4. REPLACE CONTROL VALVE WITH TCM

1. Replace control valve with TCM. Refer to [AT-215, "Control Valve with TCM and A/T Fluid Temperature Sensor 2"](#).

2. Perform [AT-119, "Diagnosis Procedure"](#).

OK or NG

OK >> **INSPECTION END**

NG >> Confirm malfunction phenomena by "ROAD TEST" to repair malfunctioning part. Refer to [AT-49, "Inspections Before Trouble Diagnosis"](#).

A

B

AT

D

E

F

G

H

I

J

K

L

M

N

O

P

# DTC P0734 A/T 4TH GEAR FUNCTION

< SERVICE INFORMATION >

## DTC P0734 A/T 4TH GEAR FUNCTION

### Description

INFOID:000000001375127

This malfunction is detected when the A/T does not shift into 4th gear position as instructed by TCM. This is not only caused by electrical malfunction (circuits open or shorted) but also by mechanical malfunction such as control valve sticking, improper solenoid valve operation.

### On Board Diagnosis Logic

INFOID:000000001375128

Diagnostic trouble code "P0734 A/T 4TH GR FNCTN" with CONSULT-III or 21st judgment flicker without CONSULT-III is detected when TCM detects any inconsistency in the actual gear ratio.

### Possible Cause

INFOID:000000001375129

- Harness or connectors  
(Solenoid circuits are open or shorted.)
- Input clutch solenoid valve
- Front brake solenoid valve
- Direct clutch solenoid valve
- High and low reverse clutch solenoid valve
- Each clutch
- Hydraulic control circuit

### DTC Confirmation Procedure

INFOID:000000001375130

#### **CAUTION:**

**Always drive vehicle at a safe speed.**

#### **NOTE:**

**If "DTC Confirmation Procedure" has been previously performed, always turn ignition switch OFF and wait at least 10 seconds before performing the next test.**

After the repair, perform the following procedure to confirm the malfunction is eliminated.

#### WITH CONSULT-III

1. Start the engine and select "DATA MONITOR" mode for "TRANSMISSION" with CONSULT-III.
2. Make sure that "ATF TEMP 1" is within the following range.  
**ATF TEMP 1: 20°C – 140°C**  
If out of range, drive vehicle to warm ATF or stop engine to cool ATF.
3. Select "4TH GR FNCTN P0734" of "DTC WORK SUPPORT" mode for "TRANSMISSION" with CONSULT-III.
4. Drive vehicle and maintain the following conditions.  
**VEHICLE SPEED: 10 km/h (6 MPH) or more**  
**ACCELE POSI: 0.6/8 or more**  
**ENGINE SPEED: TURBINE REV – 50 rpm or more**  
**TURBINE REV: 300 rpm or more**  
**GEAR: "4" position**  
**MANU MODE SW: ON**
5. Keep the current driving status for at least 5 consecutive seconds if CONSULT-III screen changes from "OUT OF CONDITION" to "TESTING".  
**CAUTION:**  
**If "TESTING" does not appear on CONSULT-III for a long time, select "SELF-DIAG RESULTS". In case a 1st trip DTC other than P0734 is shown, refer to "[AT-84, "CONSULT-III Function \(TRANSMISSION\)"](#)".**  
If "COMPLETED RESULT NG" is detected, go to [AT-121, "Diagnosis Procedure"](#).  
If "STOP VEHICLE" is detected, go to the following step.
6. Stop vehicle.
7. Drive vehicle in "D" position allowing it to shift from 1st to 5th gear and check shift timing and shift shock.
  - Touch "OK" to complete the inspection when normally shifted from the 1st to 5th gear.
  - Touch "NG" when an unusual shift shock, etc. occurs in spite of shifting from the 1st to 5th gear. Go to [AT-49, "Inspections Before Trouble Diagnosis"](#).
  - Perform [AT-84, "CONSULT-III Function \(TRANSMISSION\)"](#) when not shifted from the 1st to 5th gear. (Neither "OK" nor "NG" are indicated.)



# DTC P0734 A/T 4TH GEAR FUNCTION

< SERVICE INFORMATION >

## Diagnosis Procedure

INFOID:000000001375131

### 1. CHECK CAN COMMUNICATION LINE

#### With CONSULT-III

- Perform self-diagnosis.

#### Without CONSULT-III

- Perform self-diagnosis. Refer to [AT-91, "Diagnosis Procedure without CONSULT-III"](#).

Is a malfunction in the CAN communication indicated in the results?

YES >> Check CAN communication line. Refer to [AT-94](#).

NO >> GO TO 2.

### 2. CHECK TCM POWER SUPPLY AND GROUND CIRCUIT

Check TCM power supply and ground circuit. Refer to [AT-160](#).

OK or NG

OK >> GO TO 3.

NG >> Repair or replace damaged parts.

### 3. DETECT MALFUNCTION ITEM

Check A/T assembly harness connector pin terminals for damage or loose connection with harness connector.

OK or NG

OK >> GO TO 4.

NG >> Repair or replace damaged parts.

### 4. REPLACE CONTROL VALVE WITH TCM

1. Replace control valve with TCM. Refer to [AT-215, "Control Valve with TCM and A/T Fluid Temperature Sensor 2"](#).

2. Perform [AT-120, "DTC Confirmation Procedure"](#).

OK or NG

OK >> **INSPECTION END**

NG >> Confirm malfunction phenomena by "ROAD TEST" to repair malfunctioning part. Refer to [AT-49, "Inspections Before Trouble Diagnosis"](#).

A

B

AT

D

E

F

G

H

I

J

K

L

M

N

O

P

# DTC P0735 A/T 5TH GEAR FUNCTION

< SERVICE INFORMATION >

## DTC P0735 A/T 5TH GEAR FUNCTION

### Description

INFOID:000000001375132

This malfunction is detected when the A/T does not shift into 5th gear position as instructed by TCM. This is not only caused by electrical malfunction (circuits open or shorted) but also by mechanical malfunction such as control valve sticking, improper solenoid valve operation.

### On Board Diagnosis Logic

INFOID:000000001375133

Diagnostic trouble code "P0735 A/T 5TH GR FNCTN" with CONSULT-III or 22nd judgment flicker without CONSULT-III is detected when TCM detects any inconsistency in the actual gear ratio.

### Possible Cause

INFOID:000000001375134

- Harness or connectors  
(Solenoid circuits are open or shorted.)
- Input clutch solenoid valve
- Front brake solenoid valve
- Direct clutch solenoid valve
- High and low reverse clutch solenoid valve
- Each clutch
- Hydraulic control circuit

### DTC Confirmation Procedure

INFOID:000000001375135

#### **CAUTION:**

**Always drive vehicle at a safe speed.**

#### **NOTE:**

**If "DTC Confirmation Procedure" has been previously performed, always turn ignition switch OFF and wait at least 10 seconds before performing the next test.**

After the repair, perform the following procedure to confirm the malfunction is eliminated.

#### WITH CONSULT-III

1. Start the engine and select "DATA MONITOR" mode for "TRANSMISSION" with CONSULT-III.
2. Make sure that "ATF TEMP 1" is within the following range.  
**ATF TEMP 1: 20°C – 140°C**  
If out of range, drive vehicle to warm ATF or stop engine to cool ATF.
3. Select "5TH GR FNCTN P0735" of "DTC WORK SUPPORT" mode for "TRANSMISSION" with CONSULT-III.
4. Drive vehicle and maintain the following conditions.  
**VEHICLE SPEED: 10 km/h (6 MPH) or more**  
**ACCELE POSI: 0.6/8 or more**  
**ENGINE SPEED: TURBINE REV – 50 rpm or more**  
**TURBINE REV: 300 rpm or more**  
**GEAR: "5" position**  
**MANU MODE SW: ON**
5. Keep the current driving status for at least 5 consecutive seconds if CONSULT-III screen changes from "OUT OF CONDITION" to "TESTING".  
**CAUTION:**  
**If "TESTING" does not appear on CONSULT-III for a long time, select "SELF-DIAG RESULTS". In case a 1st trip DTC other than P0735 is shown, refer to "[AT-84, "CONSULT-III Function \(TRANSMISSION\)"](#)".**  
If "COMPLETED RESULT NG" is detected, go to [AT-123, "Diagnosis Procedure"](#).  
If "STOP VEHICLE" is detected, go to the following step.
6. Stop vehicle.
7. Drive vehicle in "D" position allowing it to shift from 1st to 5th gear and check shift timing and shift shock.
  - Touch "OK" to complete the inspection when normally shifted from the 1st to 5th gear.
  - Touch "NG" when an unusual shift shock, etc. occurs in spite of shifting from the 1st to 5th gear. Go to [AT-49, "Inspections Before Trouble Diagnosis"](#).
  - Perform [AT-84, "CONSULT-III Function \(TRANSMISSION\)"](#) when not shifted from the 1st to 5th gear. (Neither "OK" nor "NG" are indicated.)

# DTC P0735 A/T 5TH GEAR FUNCTION

< SERVICE INFORMATION >

## Diagnosis Procedure

INFOID:000000001375136

### 1. CHECK CAN COMMUNICATION LINE

#### With CONSULT-III

- Perform self-diagnosis.

#### Without CONSULT-III

- Perform self-diagnosis. Refer to [AT-91, "Diagnosis Procedure without CONSULT-III"](#).

Is a malfunction in the CAN communication indicated in the results?

YES >> Check CAN communication line. Refer to [AT-94](#).

NO >> GO TO 2.

### 2. CHECK TCM POWER SUPPLY AND GROUND CIRCUIT

Check TCM power supply and ground circuit. Refer to [AT-160](#).

OK or NG

OK >> GO TO 3.

NG >> Repair or replace damaged parts.

### 3. DETECT MALFUNCTION ITEM

Check A/T assembly harness connector pin terminals for damage or loose connection with harness connector.

OK or NG

OK >> GO TO 4.

NG >> Repair or replace damaged parts.

### 4. REPLACE CONTROL VALVE WITH TCM

1. Replace control valve with TCM. Refer to [AT-215, "Control Valve with TCM and A/T Fluid Temperature Sensor 2"](#).

2. Perform [AT-122, "DTC Confirmation Procedure"](#).

OK or NG

OK >> **INSPECTION END**

NG >> Confirm malfunction phenomena by "ROAD TEST" to repair malfunctioning part. Refer to [AT-49, "Inspections Before Trouble Diagnosis"](#).

A  
B  
AT  
D  
E  
F  
G  
H  
I  
J  
K  
L  
M  
N  
O  
P

# DTC P0740 TORQUE CONVERTER CLUTCH SOLENOID VALVE

< SERVICE INFORMATION >

## DTC P0740 TORQUE CONVERTER CLUTCH SOLENOID VALVE

### Description

INFOID:000000001327209

- The torque converter clutch solenoid valve is activated, with the gear in D5, M3, M4 and M5 by the TCM in response to signals sent from the vehicle speed sensor and accelerator pedal position sensor (throttle position sensor). Torque converter clutch piston operation will then be controlled.
- Lock-up operation, however, is prohibited when A/T fluid temperature is too low.
- When the accelerator pedal is depressed (less than 1.0/8) in lock-up condition, the engine speed should not change abruptly. If there is a big jump in engine speed, there is no lock-up.

### CONSULT-III Reference Value in Data Monitor Mode

INFOID:000000001327210

Item name	Condition	Display value (Approx.)
TCC SOLENOID	Slip lock-up is active	0.2 - 0.4 A
	Lock-up is active	0.4 - 0.6 A

### On Board Diagnosis Logic

INFOID:000000001327211

Diagnostic trouble code "P0740 TCC SOLENOID/CIRC" with CONSULT-III or 3rd judgement flicker without CONSULT-III is detected under the following conditions.

- When TCM detects an improper voltage drop when it tries to operate the solenoid valve.
- When TCM detects as irregular by comparing target value with monitor value.

### Possible Cause

INFOID:000000001327212

- Torque converter clutch solenoid valve
- Harness or connectors  
(Solenoid circuit is open or shorted.)

### DTC Confirmation Procedure

INFOID:000000001327213

#### **CAUTION:**

**Always drive vehicle at a safe speed.**

#### **NOTE:**

**If "DTC Confirmation Procedure" has been previously performed, always turn ignition switch "OFF" and wait at least 10 seconds before performing the next test.**

After the repair, perform the following procedure to confirm the malfunction is eliminated.

#### WITH CONSULT-III

1. Turn ignition switch ON.
2. Select "SELECTION FROM MENU" in "DATA MONITOR" mode for "TRANSMISSION" with CONSULT-III and check monitor "VHCL/S SE-A/T", "ACCELE POSI" and "SLCT LVR POSI".
3. Touch "START".
4. Start engine and maintain the following conditions for at least 5 consecutive seconds.  
**VHCL/S SE-A/T: 80 km/h (50 MPH) or more**  
**ACCELE POSI: 0.5/8 - 1.0/8**  
**SLCT LVR POSI: "D" position**  
**Driving location: Driving the vehicle uphill (increased engine load) will help maintain the driving conditions required for this test.**
5. If DTC is detected go to [AT-124, "Diagnosis Procedure"](#).

#### WITH GST

Follow the procedure "WITH CONSULT-III".

### Diagnosis Procedure

INFOID:000000001327214

#### 1. CHECK INPUT SIGNAL

##### With CONSULT-III

1. Turn ignition switch ON.

# DTC P0740 TORQUE CONVERTER CLUTCH SOLENOID VALVE

## < SERVICE INFORMATION >

2. Select "MAIN SIGNALS" in "DATA MONITOR" mode for "TRANSMISSION" with CONSULT-III.
3. Start engine.
4. Read out the value of "TCC SOLENOID" while driving.

Item name	Condition	Display value (Approx.)
TCC SOLENOID	Slip lock-up is active	0.2 - 0.4 A
	Lock-up is active	0.4 - 0.6 A

### OK or NG

- OK >> GO TO 4.
- NG >> GO TO 2.

## 2. CHECK TCM POWER SUPPLY AND GROUND CIRCUIT

Check TCM power supply and ground circuit. Refer to [AT-160](#).

### OK or NG

- OK >> GO TO 3.
- NG >> Repair or replace damaged parts.

## 3. DETECT MALFUNCTIONING ITEM

Check A/T assembly harness connector pin terminals for damage or loose connection with harness connector.

### OK or NG

- OK >> Replace the control valve with TCM. Refer to [AT-215. "Control Valve with TCM and A/T Fluid Temperature Sensor 2"](#).
- NG >> Repair or replace damaged parts.

## 4. CHECK DTC

Perform [AT-124. "DTC Confirmation Procedure"](#).

### OK or NG

- OK >> **INSPECTION END**
- NG >> GO TO 2.

A  
B  
AT  
D  
E  
F  
G  
H  
I  
J  
K  
L  
M  
N  
O  
P

# DTC P0744 A/T TCC S/V FUNCTION (LOCK-UP)

< SERVICE INFORMATION >

## DTC P0744 A/T TCC S/V FUNCTION (LOCK-UP)

### Description

INFOID:000000001327215

This malfunction is detected when the A/T does not shift into 5th gear position or the torque converter clutch does not lock-up as instructed by the TCM. This is not only caused by electrical malfunction (circuits open or shorted) but also by mechanical malfunction such as control valve sticking, improper solenoid valve operation, etc.

### CONSULT-III Reference Value in Data Monitor Mode

INFOID:000000001327216

Item name	Condition	Display value (Approx.)
TCC SOLENOID	Slip lock-up is active	0.2 - 0.4 A
	Lock-up is active	0.4 - 0.6 A

### On Board Diagnosis Logic

INFOID:000000001327217

Diagnostic trouble code "P0744 A/T TCC S/V FNCTN" with CONSULT-III or 3rd judgement flicker without CONSULT-III is detected under the following conditions.

- When A/T cannot perform lock-up even if electrical circuit is good.
- When TCM detects as irregular by comparing difference value with slip rotation.

### Possible Cause

INFOID:000000001327218

- Harness or connectors  
(Solenoid circuit is open or shorted.)
- Torque converter clutch solenoid valve
- Hydraulic control circuit

### DTC Confirmation Procedure

INFOID:000000001327219

#### **CAUTION:**

**Always drive vehicle at a safe speed.**

#### **NOTE:**

**If "DTC Confirmation Procedure" has been previously performed, always turn ignition switch OFF and wait at least 10 seconds before performing the next test.**

After the repair, perform the following procedure to confirm the malfunction is eliminated.

#### ④ WITH CONSULT-III

1. Start engine.
2. Select "DATA MONITOR" mode for "TRANSMISSION" with CONSULT-III.
3. Drive vehicle and maintain the following conditions for at least 30 consecutive seconds.  
**ACCELE POSI: More than 1.0/8**  
**SLCT LVR POSI: "D" position**  
**TCC SOLENOID: 0.4 - 0.6 A**  
**VEHICLE SPEED: 80 km/h (50 MPH) or more**  
**Driving location: Driving the vehicle uphill (increased engine load) will help maintain the driving conditions required for this test.**
4. If DTC is detected, go to [AT-126. "Diagnosis Procedure"](#).

#### ④ WITH GST

Follow the procedure "WITH CONSULT-III".

### Diagnosis Procedure

INFOID:000000001327220

#### 1. CHECK INPUT SIGNAL

##### ④ With CONSULT-III

1. Turn ignition switch ON.
2. Select "MAIN SIGNALS" in "DATA MONITOR" mode for "TRANSMISSION" with CONSULT-III.
3. Start the engine.

## DTC P0744 A/T TCC S/V FUNCTION (LOCK-UP)

### < SERVICE INFORMATION >

4. Read out the value of "TCC SOLENOID" while driving.

Item name	Condition	Display value (Approx.)
TCC SOLENOID	Slip lock-up is active	0.2 - 0.4 A
	Lock-up is active	0.4 - 0.6 A

#### OK or NG

OK >> GO TO 4.

NG >> GO TO 2.

### 2. CHECK TCM POWER SUPPLY AND GROUND CIRCUIT

Check TCM power supply and ground circuit. Refer to [AT-160](#).

#### OK or NG

OK >> GO TO 3.

NG >> Repair or replace damaged parts.

### 3. DETECT MALFUNCTIONING ITEM

Check A/T assembly harness connector pin terminals for damage or loose connection with harness connector.

#### OK or NG

OK >> Replace the control valve with TCM. Refer to [AT-215, "Control Valve with TCM and A/T Fluid Temperature Sensor 2"](#).

NG >> Repair or replace damaged parts.

### 4. CHECK DTC

Perform [AT-126, "DTC Confirmation Procedure"](#).

#### OK or NG

OK >> **INSPECTION END**

NG >> GO TO 2.

A  
B  
AT  
D  
E  
F  
G  
H  
I  
J  
K  
L  
M  
N  
O  
P

# DTC P0745 LINE PRESSURE SOLENOID VALVE

< SERVICE INFORMATION >

## DTC P0745 LINE PRESSURE SOLENOID VALVE

### Description

INFOID:000000001327221

The line pressure solenoid valve regulates the oil pump discharge pressure to suit the driving condition in response to a signal sent from the TCM.

### CONSULT-III Reference Value in Data Monitor Mode

INFOID:000000001327222

Item name	Condition	Display value (Approx.)
LINE PRES SOL	During driving	0.2 - 0.6 A

### On Board Diagnosis Logic

INFOID:000000001327223

Diagnostic trouble code "P0745 L/PRESS SOL/CIRC" with CONSULT-III or 4th judgement flicker without CONSULT-III is detected under the following conditions.

- When TCM detects an improper voltage drop when it tries to operate the solenoid valve.
- When TCM detects as irregular by comparing target value with monitor value.

### Possible Cause

INFOID:000000001327224

- Harness or connectors  
(Solenoid circuit is open or shorted.)
- Line pressure solenoid valve

### DTC Confirmation Procedure

INFOID:000000001327225

#### NOTE:

If "DTC Confirmation Procedure" has been previously performed, always turn ignition switch OFF and wait at least 10 seconds before performing the next test.

After the repair, perform the following procedure to confirm the malfunction is eliminated.

#### ④ WITH CONSULT-III

1. Turn ignition switch ON.
2. Select "MAIN SIGNALS" in "DATA MONITOR" mode for "TRANSMISSION" with CONSULT-III.
3. Touch "START".
4. Engine start and wait at least 5 seconds.
5. If DTC is detected, go to ["AT-128. "Diagnosis Procedure"](#).

#### ④ WITH GST

Follow the procedure "WITH CONSULT-III".

### Diagnosis Procedure

INFOID:000000001327226

#### 1. CHECK INPUT SIGNAL

##### ④ With CONSULT-III

1. Turn ignition switch ON.
2. Select "MAIN SIGNALS" in "DATA MONITOR" mode for "TRANSMISSION" with CONSULT-III.
3. Start engine.
4. Read out the value of "LINE PRES SOL" while driving.

Item name	Condition	Display value (Approx.)
LINE PRES SOL	During driving	0.2 - 0.6 A

#### OK or NG

- OK >> GO TO 4.
- NG >> GO TO 2.

#### 2. CHECK TCM POWER SUPPLY AND GROUND CIRCUIT

Check TCM power supply and ground circuit. Refer to [AT-160](#).



# DTC P0745 LINE PRESSURE SOLENOID VALVE

< SERVICE INFORMATION >

---

OK or NG

OK >> GO TO 3.

NG >> Repair or replace damaged parts.

## 3. DETECT MALFUNCTIONING ITEM

---

Check A/T assembly harness connector pin terminals for damage or loose connection with harness connector

OK or NG

OK >> Replace the control valve with TCM. Refer to [AT-215. "Control Valve with TCM and A/T Fluid Temperature Sensor 2"](#).

NG >> Repair or replace damaged parts.

## 4. CHECK DTC

---

Perform [AT-128. "DTC Confirmation Procedure"](#).

OK or NG

OK >> **INSPECTION END**

NG >> GO TO 2.

A  
B  
AT  
D  
E  
F  
G  
H  
I  
J  
K  
L  
M  
N  
O  
P

# DTC P1705 THROTTLE POSITION SENSOR

< SERVICE INFORMATION >

## DTC P1705 THROTTLE POSITION SENSOR

### Description

INFOID:000000001327227

Electric throttle control actuator consists of throttle control motor, accelerator pedal position sensor, throttle position sensor, etc. The actuator sends a signal to the ECM, and ECM sends signals to TCM with CAN communication.

### CONSULT-III Reference Value in Data Monitor Mode

INFOID:000000001327228

Item name	Condition	Display value (Approx.)
ACCELE POSI	Released accelerator pedal.	0.0/8
	Fully depressed accelerator pedal.	8.0/8

### On Board Diagnosis Logic

INFOID:000000001327229

Diagnostic trouble code "P1705 TP SEN/CIRC A/T" with CONSULT-III or 15th judgement flicker without CONSULT-III is detected when TCM does not receive the proper accelerator pedal position signals (input by CAN communication) from ECM.

### Possible Cause

INFOID:000000001327230

Harness or connectors  
(Sensor circuit is open or shorted.)

### DTC Confirmation Procedure

INFOID:000000001327231

#### NOTE:

**If "DTC Confirmation Procedure" has been previously performed, always turn ignition switch OFF and wait at least 10 seconds before performing the next test.**

After the repair, perform the following procedure to confirm the malfunction is eliminated.

#### ④ WITH CONSULT-III

1. Turn ignition switch ON.
2. Select "ECU INPUT SIGNALS" in "DATA MONITOR" mode for "TRANSMISSION" with CONSULT-III.
3. Touch "START".
4. Start engine and let it idle for 1 second.
5. If DTC is detected, go to [AT-130. "Diagnosis Procedure"](#).

### Diagnosis Procedure

INFOID:000000001327232

#### 1. CHECK CAN COMMUNICATION LINE

##### ④ With CONSULT-III

- Perform the self-diagnosis.

##### ⊗ Without CONSULT-III

- Perform the self-diagnosis. Refer to [AT-91. "Diagnosis Procedure without CONSULT-III"](#).

Is a malfunction in the CAN communication indicated in the results?

- YES >> Check CAN communication line. Refer to [AT-94](#).  
NO >> GO TO 2.

#### 2. CHECK DTC WITH TCM

##### ④ With CONSULT-III

1. Turn ignition switch ON.
2. Select "ECU INPUT SIGNALS" in "DATA MONITOR" mode for "TRANSMISSION" with CONSULT-III.
3. Depress accelerator pedal and read out the value of "ACCELE POSI".

# DTC P1705 THROTTLE POSITION SENSOR

## < SERVICE INFORMATION >

Item name	Condition	Display value (Approx.)
ACCELE POSI	Released accelerator pedal.	0.0/8
	Fully depressed accelerator pedal.	8.0/8

4. Select "SELF-DIAG RESULTS" mode for "TRANSMISSION" with CONSULT-III. Refer to [AT-84, "CONSULT-III Function \(TRANSMISSION\)"](#).

### OK or NG

- OK >> GO TO 4.  
NG >> GO TO 3.

## 3.CHECK DTC WITH ECM

### Ⓜ With CONSULT-III

- Turn ignition switch ON.
- Select "SELF-DIAG RESULTS" mode for "ENGINE" with CONSULT-III. Refer to [EC-117, "CONSULT-III Function \(ENGINE\)"](#) (for VQ35DE) or [EC-695, "CONSULT-III Function \(ENGINE\)"](#) (for VK45DE).

### OK or NG

- OK >> GO TO 4.  
NG >> Check the DTC detected item. Refer to [EC-117, "CONSULT-III Function \(ENGINE\)"](#) (for VQ35DE) or [EC-695, "CONSULT-III Function \(ENGINE\)"](#) (for VK45DE).  
• If CAN communication line is detected, go to [AT-94](#).

## 4.CHECK DTC

Perform [AT-130, "DTC Confirmation Procedure"](#).

### OK or NG

- OK >> **INSPECTION END**  
NG >> GO TO 5.

## 5.CHECK TCM POWER SUPPLY AND GROUND CIRCUIT

Check TCM power supply and ground circuit. Refer to [AT-160](#).

### OK or NG

- OK >> GO TO 6.  
NG >> Repair or replace damaged parts.

## 6.DETECT MALFUNCTIONING ITEM

Check A/T assembly harness connector pin terminals for damage or loose connection with harness connector.

### OK or NG

- OK >> Replace the control valve with TCM. Refer to [AT-215, "Control Valve with TCM and A/T Fluid Temperature Sensor 2"](#).  
NG >> Repair or replace damaged parts.

# DTC P1710 A/T FLUID TEMPERATURE SENSOR CIRCUIT

< SERVICE INFORMATION >

## DTC P1710 A/T FLUID TEMPERATURE SENSOR CIRCUIT

### Description

INFOID:000000001327233

The A/T fluid temperature sensor detects the A/T fluid temperature and sends a signal to the TCM.

### CONSULT-III Reference Value in Data Monitor Mode

INFOID:000000001327234

Item name	Condition °C (°F)	Display value (Approx.)
ATF TEMP SE 1	0 (32) - 20 (68) - 80 (176)	3.3 - 2.7 - 0.9 V
ATF TEMP SE 2		3.3 - 2.5 - 0.7 V

### On Board Diagnosis Logic

INFOID:000000001327235

Diagnostic trouble code "P1710 (A/T), P0710 (ENGINE) ATF TEMP SEN/CIRC" with CONSULT-III or 10th judgement flicker without CONSULT-III is detected when TCM receives an excessively low or high voltage from the sensor.

### Possible Cause

INFOID:000000001327236

- Harness or connectors  
(Sensor circuit is open or shorted.)
- A/T fluid temperature sensors 1 and/or 2

### DTC Confirmation Procedure

INFOID:000000001327237

#### **CAUTION:**

**Always drive vehicle at a safe speed.**

#### **NOTE:**

**If "DTC Confirmation Procedure" has been previously performed, always turn ignition switch OFF and wait at least 10 seconds before performing the next test.**

After the repair, perform the following procedure to confirm the malfunction is eliminated.

#### Ⓟ WITH CONSULT-III

1. Turn ignition switch ON.
2. Select "SELECTION FROM MENU" in "DATA MONITOR" mode for "TRANSMISSION" with CONSULT-III and check monitor "VHCL/S SE-A/T", "ACCELE POSI" and "SLCT LVR POSI".
3. Touch "START".
4. Start engine and maintain the following conditions for at least 10 minutes (Total). (It is not necessary to maintain continuously.)  
**VHCL/S SE-A/T: 10 km/h (6 MPH) or more**  
**ACCELE POSI: More than 1.0/8**  
**SLCT LVR POSI: "D" position**
5. If DTC is detected, go to [AT-133, "Diagnosis Procedure"](#).

#### Ⓢ WITH GST

Follow the procedure "WITH CONSULT-III".

# DTC P1710 A/T FLUID TEMPERATURE SENSOR CIRCUIT

< SERVICE INFORMATION >

## Wiring Diagram - AT - FTS

INFOID:000000001327238

### AT-FTS-01

: DETECTABLE LINE FOR DTC  
 : NON-DETECTABLE LINE FOR DTC

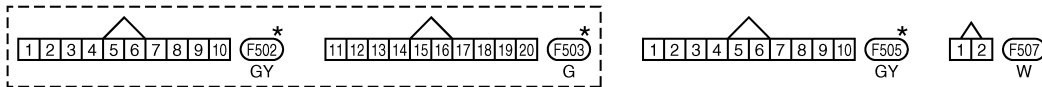
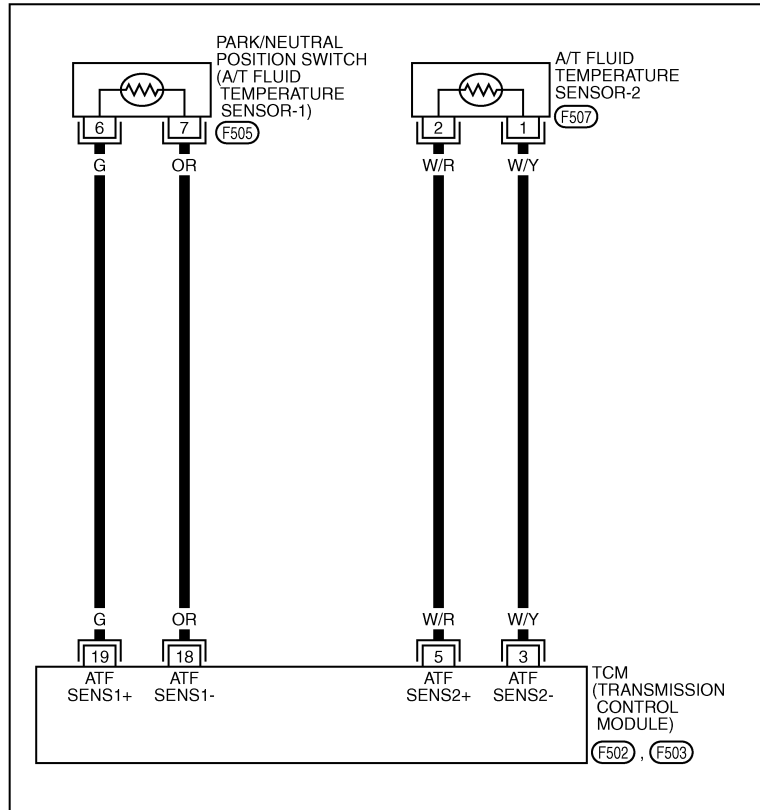

\*: THIS CONNECTOR IS NOT SHOWN IN "HARNESS LAYOUT", PG SECTION.

## Diagnosis Procedure

### 1. CHECK A/T FLUID TEMPERATURE SENSOR 1 SIGNAL

**With CONSULT-III**

1. Start engine.

TCWM0251E

INFOID:000000001327239

# DTC P1710 A/T FLUID TEMPERATURE SENSOR CIRCUIT

## < SERVICE INFORMATION >

2. Select "ECU INPUT SIGNALS" in "DATA MONITOR" mode for "TRANSMISSION" with CONSULT-III.
3. Read out the value of "ATF TEMP SE 1".

Item name	Condition °C (°F)	Display value (Approx.)
ATF TEMP SE 1	0 (32) - 20 (68) - 80 (176)	3.3 - 2.7 - 0.9 V

### OK or NG

- OK >> GO TO 2.  
 NG >> GO TO 3.

## 2.CHECK A/T FLUID TEMPERATURE SENSOR 2 SIGNAL

### Ⓜ With CONSULT-III

1. Start engine.
2. Select "ECU INPUT SIGNALS" in "DATA MONITOR" mode for "TRANSMISSION" with CONSULT-III.
3. Read out the value of "ATF TEMP SE 2".

Item name	Condition °C (°F)	Display value (Approx.)
ATF TEMP SE 2	0 (32) - 20 (68) - 80 (176)	3.3 - 2.5 - 0.7 V

### OK or NG

- OK >> GO TO 8.  
 NG >> GO TO 5.

## 3.CHECK A/T FLUID TEMPERATURE SENSOR 1

Check A/T fluid temperature sensor 1. Refer to [AT-135. "Component Inspection"](#).

### OK or NG

- OK >> GO TO 4.  
 NG >> Replace the control valve with TCM. Refer to [AT-215. "Control Valve with TCM and A/T Fluid Temperature Sensor 2"](#).

## 4.CHECK SUB-HARNESS

1. Disconnect park/neutral position switch connector and TCM connector.
2. Check continuity between park/neutral position switch connector terminals and TCM connector terminals.

Item	Connector	Terminal	Continuity
Park/neutral position switch connector	F505	6	Yes
TCM connector	F503	19	
Park/neutral position switch connector	F505	7	Yes
TCM connector	F503	18	

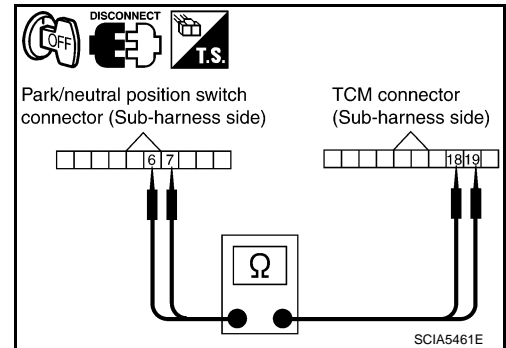

3. If OK, check harness for short to ground and short to power.

### OK or NG

- OK >> GO TO 7.  
 NG >> Replace open circuit or short to ground and short to power in harness or connectors.

## 5.CHECK A/T FLUID TEMPERATURE SENSOR 2

Check A/T fluid temperature sensor 2. Refer to [AT-135. "Component Inspection"](#).

### OK or NG

- OK >> GO TO 6.  
 NG >> Replace the A/T fluid temperature sensor 2. Refer to [AT-215. "Control Valve with TCM and A/T Fluid Temperature Sensor 2"](#).

## 6.CHECK TERMINAL CORD ASSEMBLY

1. Disconnect A/T fluid temperature sensor 2 connector and TCM connector.

# DTC P1710 A/T FLUID TEMPERATURE SENSOR CIRCUIT

## < SERVICE INFORMATION >

- Check continuity between A/T fluid temperature sensor 2 connector terminals and TCM connector terminals.

Item	Connector	Terminal	Continuity
A/T fluid temperature sensor 2 connector	F507	1	Yes
TCM connector	F502	3	
A/T fluid temperature sensor 2 connector	F507	2	Yes
TCM connector	F502	5	

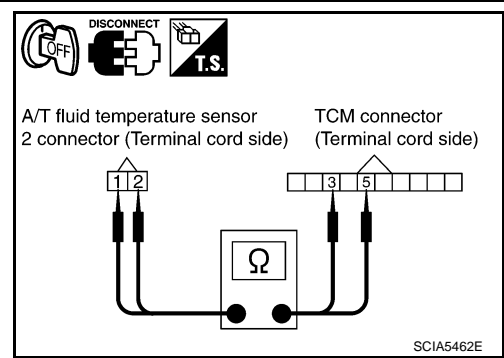

- If OK, check harness for short to ground and short to power.

### OK or NG

OK >> GO TO 7.

NG >> Replace open circuit or short to ground and short to power in harness or connectors.

## 7. CHECK TCM POWER SUPPLY AND GROUND CIRCUIT

- Check TCM power supply and ground circuit. Refer to [AT-160](#).
- Reinstall any part removed.

### OK or NG

OK >> Replace the control valve with TCM. Refer to [AT-215, "Control Valve with TCM and A/T Fluid Temperature Sensor 2"](#).

NG >> Repair or replace damaged parts.

## 8. CHECK DTC

Perform [AT-132, "DTC Confirmation Procedure"](#).

### OK or NG

OK >> **INSPECTION END**

NG >> GO TO 1.

## Component Inspection

INFOID:000000001327240

### A/T FLUID TEMPERATURE SENSOR 1

- Remove control valve with TCM. Refer to [AT-215, "Control Valve with TCM and A/T Fluid Temperature Sensor 2"](#).
- Check resistance between terminals.

Name	Connector	Terminal	Temperature °C (°F)	Resistance (Approx.)
A/T fluid temperature sensor 1	F505	6 - 7	0 (32)	15 kΩ
			20 (68)	6.5 kΩ
			80 (176)	0.9 kΩ

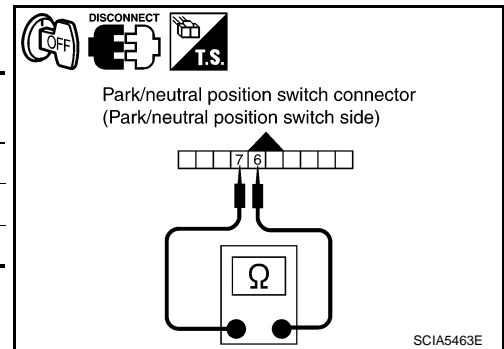

- If NG, replace the control valve with TCM. Refer to [AT-215, "Control Valve with TCM and A/T Fluid Temperature Sensor 2"](#).

### A/T FLUID TEMPERATURE SENSOR 2

- Remove A/T fluid temperature sensor 2. Refer to [AT-215, "Control Valve with TCM and A/T Fluid Temperature Sensor 2"](#).

# DTC P1710 A/T FLUID TEMPERATURE SENSOR CIRCUIT

## < SERVICE INFORMATION >

2. Check resistance between terminals.

Name	Connector	Terminal	Temperature °C (°F)	Resistance (Ap- prox.)
A/T fluid temperature sensor 2	F507	1 - 2	0 (32)	10 kΩ
			20 (68)	4 kΩ
			80 (176)	0.5 kΩ

3. If NG, replace the A/T fluid temperature sensor 2. Refer to [AT-215](#), "Control Valve with TCM and A/T Fluid Temperature Sensor 2".

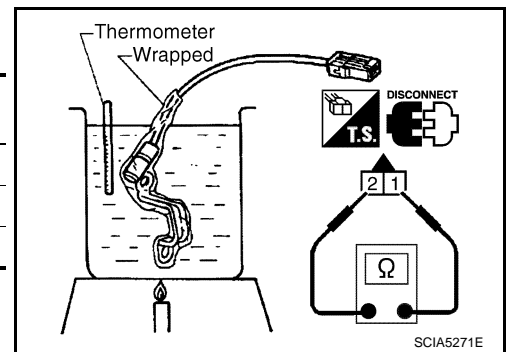



# DTC P1721 VEHICLE SPEED SENSOR MTR

< SERVICE INFORMATION >

## DTC P1721 VEHICLE SPEED SENSOR MTR

### Description

INFOID:000000001327241

The vehicle speed sensor-MTR signal is transmitted from unified meter and A/C amp. to TCM by CAN communication line. The signal functions as an auxiliary device to the revolution sensor when it is malfunctioning. The TCM will then use the vehicle speed sensor-MTR signal.

### CONSULT-III Reference Value in Data Monitor Mode

INFOID:000000001327242

Item name	Condition	Display value
VHCL/S SE-MTR	During driving	Approximately matches the speedometer reading.

### On Board Diagnosis Logic

INFOID:000000001327243

Diagnostic trouble code "P1721 VEH SPD SE/CIR-MTR" with CONSULT-III is detected when TCM does not receive the proper vehicle speed sensor MTR signal (input by CAN communication) from combination meter.

### Possible Cause

INFOID:000000001327244

Harness or connectors  
(Sensor circuit is open or shorted.)

### DTC Confirmation Procedure

INFOID:000000001327245

#### **CAUTION:**

**Always drive vehicle at a safe speed.**

#### **NOTE:**

If "DTC Confirmation Procedure" has been previously performed, always turn ignition switch OFF and wait at least 10 seconds before performing the next test.

After the repair, perform the following procedure to confirm the malfunction is eliminated.

#### ④ WITH CONSULT-III

1. Turn ignition switch ON.
2. Select "ECU INPUT SIGNALS" in "DATA MONITOR" mode for "TRANSMISSION" with CONSULT-III.
3. Touch "START".
4. Start engine and maintain the following conditions for at least 5 consecutive seconds.  
**ACCELE POSI: 1.0/8 or less**  
**VHCL/S SE-MTR: 30 km/h (17 MPH) or more**
5. If DTC is detected, go to [AT-137, "Diagnosis Procedure"](#).

### Diagnosis Procedure

INFOID:000000001327246

#### 1. CHECK CAN COMMUNICATION LINE

##### ④ With CONSULT-III

- Perform the self-diagnosis.

##### ⊗ Without CONSULT-III

- Perform the self-diagnosis. Refer to [AT-91, "Diagnosis Procedure without CONSULT-III"](#).

Is malfunction in the CAN communication indicated in the result?

- YES >> Check CAN communication line. Refer to [AT-94](#).  
NO >> GO TO 2.

#### 2. CHECK INPUT SIGNAL

##### ④ With CONSULT-III

1. Start engine.
2. Select "ECU INPUT SIGNALS" in "DATA MONITOR" mode for "TRANSMISSION" with CONSULT-III.
3. Drive vehicle and read out the value of "VHCL/S SE-MTR".

## DTC P1721 VEHICLE SPEED SENSOR MTR

### < SERVICE INFORMATION >

---

Item name	Condition	Display value
VHCL/S SE-MTR	During driving	Approximately matches the speedometer reading.

---

#### OK or NG

OK >> GO TO 4.

NG >> GO TO 3.

### 3.CHECK COMBINATION METERS

---

Check combination meters. Refer to [DI-15, "Trouble Diagnosis"](#).

#### OK or NG

OK >> GO TO 4.

NG >> Repair or replace damaged parts.

### 4.CHECK DTC

---

Perform [AT-137, "DTC Confirmation Procedure"](#).

#### OK or NG

OK >> **INSPECTION END**

NG >> GO TO 5.

### 5.CHECK TCM POWER SUPPLY AND GROUND CIRCUIT

---

Check TCM power supply and ground circuit. Refer to [AT-160](#).

#### OK or NG

OK >> GO TO 6.

NG >> Repair or replace damaged parts.

### 6.DETECT MALFUNCTIONING ITEM

---

Check A/T assembly harness connector pin terminals for damage or loose connection with harness connector.

#### OK or NG

OK >> Replace the control valve with TCM. Refer to [AT-215, "Control Valve with TCM and A/T Fluid Temperature Sensor 2"](#).

NG >> Repair or replace damaged parts.

# DTC P1730 A/T INTERLOCK

< SERVICE INFORMATION >

## DTC P1730 A/T INTERLOCK

### Description

INFOID:000000001327247

Fail-safe function to detect interlock conditions.

### On Board Diagnosis Logic

INFOID:000000001327248

Diagnostic trouble code "P1730 A/T INTERLOCK" with CONSULT-III or 12th judgement flicker without CONSULT-III is detected when TCM does not receive the proper voltage signal from the sensor and switch. TCM monitors and compares gear position and conditions of each ATF pressure switch when gear is steady.

### Possible Cause

INFOID:000000001327249

- Harness or connectors  
(Solenoid and switch circuit is open or shorted.)
- Low coast brake solenoid valve
- ATF pressure switch 2

### DTC Confirmation Procedure

INFOID:000000001327250

#### NOTE:

If "DTC Confirmation Procedure" has been previously performed, always turn ignition switch OFF and wait at least 10 seconds before performing the next test.

After the repair, perform the following procedure to confirm the malfunction is eliminated.

#### ④ WITH CONSULT-III

1. Turn ignition switch ON.
2. Select "MAIN SIGNALS" in "DATA MONITOR" mode for "TRANSMISSION" with CONSULT-III.
3. Touch "START".
4. Start engine.
5. Drive vehicle and maintain the following conditions for at least 2 consecutive seconds.  
**SLCT LVR POSI: "D" position**
6. If DTC is detected, go to [AT-139, "Diagnosis Procedure"](#).

#### ④ WITH GST

Follow the procedure "WITH CONSULT-III".

### Judgement of A/T Interlock

INFOID:000000001327251

- When A/T Interlock is judged to be malfunctioning, the vehicle should be fixed in 2nd gear, and should be set in a condition in which it can travel.  
When one of the following fastening patterns is detected, the fail-safe function in correspondence with the individual pattern should be performed.

#### NOTE:

**When the vehicle is driven fixed in 2nd gear, a turbine revolution sensor malfunction is displayed, but this is not a turbine revolution sensor malfunction.**

- When interlock is detected at the 3rd gear or more, it is locked at the 2nd gear.

### Diagnosis Procedure

INFOID:000000001327252

## 1. SELF-DIAGNOSIS

#### ④ With CONSULT-III

1. Drive vehicle.
2. Stop vehicle and turn ignition switch OFF.
3. Turn ignition switch ON.
4. Select "SELF-DIAG RESULTS" mode for "TRANSMISSION" with CONSULT-III.

#### ⊗ Without CONSULT-III

1. Drive vehicle.
2. Stop vehicle and turn ignition switch OFF.
3. Turn ignition switch ON.

## DTC P1730 A/T INTERLOCK

### < SERVICE INFORMATION >

---

4. Perform self-diagnosis. Refer to [AT-91, "Diagnosis Procedure without CONSULT-III"](#).

#### OK or NG

OK >> GO TO 2.

NG >> Check low coast brake solenoid valve circuit and function. Refer to [AT-151](#), [AT-153](#).

### 2.CHECK DTC

---

Perform [AT-139, "DTC Confirmation Procedure"](#).

#### OK or NG

OK >> **INSPECTION END**

NG >> GO TO 3.

### 3.CHECK TCM POWER SUPPLY AND GROUND CIRCUIT

---

Check TCM power supply and ground circuit. Refer to [AT-160](#).

#### OK or NG

OK >> GO TO 4.

NG >> Repair or replace damaged parts.

### 4.DETECT MALFUNCTIONING ITEM

---

Check A/T assembly harness connector pin terminals for damage or loose connection with harness connector.

#### OK or NG

OK >> Replace the control valve with TCM. Refer to [AT-215, "Control Valve with TCM and A/T Fluid Temperature Sensor 2"](#).

NG >> Repair or replace damaged parts.

# DTC P1731 A/T 1ST ENGINE BRAKING

< SERVICE INFORMATION >

## DTC P1731 A/T 1ST ENGINE BRAKING

### Description

INFOID:000000001327253

Fail-safe function to prevent sudden decrease in speed by engine brake other than at M1 position.

### CONSULT-III Reference Value in Data Monitor Mode

INFOID:000000001327254

Item name	Condition	Display value
ON OFF SOL	Low coast brake engaged. Refer to <a href="#">AT-18</a> .	ON
	Low coast brake disengaged. Refer to <a href="#">AT-18</a> .	OFF
ATF PRES SW 2	Low coast brake engaged. Refer to <a href="#">AT-18</a> .	ON
	Low coast brake disengaged. Refer to <a href="#">AT-18</a> .	OFF

### On Board Diagnosis Logic

INFOID:000000001327255

Diagnostic trouble code "P1731 A/T 1ST E/BRAKING" with CONSULT-III or 13th judgement flicker without CONSULT-III is detected under the following conditions.

- When TCM does not receive the proper voltage signal from the sensor.
- When TCM monitors each ATF pressure switch and solenoid monitor value, and detects as irregular when engine brake of 1st gear acts other than at M1 position.

### Possible Cause

INFOID:000000001327256

- Harness or connectors  
(Sensor circuit is open or shorted.)
- Low coast brake solenoid valve
- ATF pressure switch 2

### DTC Confirmation Procedure

INFOID:000000001327257

#### **CAUTION:**

- Always drive vehicle at a safe speed.
- Be careful not to rev engine into red zone on the tachometer.

#### **NOTE:**

If "DTC Confirmation Procedure" has been previously preformed, always turn ignition switch OFF and wait at least 10 seconds before performing the next test.

After the repair, perform the following procedure to confirm the malfunction is eliminated.

#### Ⓟ WITH CONSULT-III

1. Turn ignition switch ON.
2. Select "SELECTION FROM MENU" in "DATA MONITOR" mode for "TRANSMISSION" with CONSULT-III and check monitor "ENGINE SPEED", "MANU MODE SW" and "GEAR".
3. Touch "START".
4. Start engine.
5. Drive vehicle and maintain the following conditions for at least 2 consecutive seconds.  
**ENGINE SPEED: 1,200 rpm**  
**MANU MODE SW: ON**  
**GEAR: "1" position**
6. If DTC is detected, go to [AT-141](#). "Diagnosis Procedure".

### Diagnosis Procedure

INFOID:000000001327258

#### 1. CHECK INPUT SIGNALS

##### Ⓟ With CONSULT-III

1. Start the engine.
2. Select "SELECTION FROM MENU" in "DATA MONITOR" mode for "TRANSMISSION" with CONSULT-III.
3. Drive vehicle in the "M" position (1st gear), and confirm the ON/OFF actuation of "ATF PRES SW 2" and "ON OFF SOL".

# DTC P1731 A/T 1ST ENGINE BRAKING

## < SERVICE INFORMATION >

Item name	Condition	Display value
ON OFF SOL	Low coast brake engaged. Refer to <a href="#">AT-18</a> .	ON
	Low coast brake disengaged. Refer to <a href="#">AT-18</a> .	OFF
ATF PRES SW 2	Low coast brake engaged. Refer to <a href="#">AT-18</a> .	ON
	Low coast brake disengaged. Refer to <a href="#">AT-18</a> .	OFF

### OK or NG

- OK >> GO TO 4.
- NG >> GO TO 2.

## **2.**CHECK TCM POWER SUPPLY AND GROUND CIRCUIT

Check TCM power supply and ground circuit. Refer to [AT-160](#).

### OK or NG

- OK >> GO TO 3.
- NG >> Repair or replace damaged parts.

## **3.**DETECT MALFUNCTIONING ITEM

Check A/T assembly harness connector pin terminals for damage or loose connection with harness connector.

### OK or NG

- OK >> Replace the control valve with TCM. Refer to [AT-215](#), "[Control Valve with TCM and A/T Fluid Temperature Sensor 2](#)".
- NG >> Repair or replace damaged parts.

## **4.**CHECK DTC

Perform [AT-141](#), "[DTC Confirmation Procedure](#)".

### OK or NG

- OK >> **INSPECTION END**
- NG >> GO TO 2.

# DTC P1752 INPUT CLUTCH SOLENOID VALVE

< SERVICE INFORMATION >

## DTC P1752 INPUT CLUTCH SOLENOID VALVE

### Description

INFOID:000000001327259

Input clutch solenoid valve is controlled by the TCM in response to signals sent from the PNP switch, vehicle speed sensor and accelerator pedal position sensor (throttle position sensor). Gears will then be shifted to the optimum position.

### CONSULT-III Reference Value in Data Monitor Mode

INFOID:000000001327260

Item name	Condition	Display value (Approx.)
I/C SOLENOID	Input clutch disengaged. Refer to <a href="#">AT-18</a> .	0.6 - 0.8 A
	Input clutch engaged. Refer to <a href="#">AT-18</a> .	0 - 0.05 A

### On Board Diagnosis Logic

INFOID:000000001327261

Diagnostic trouble code "P1752 I/C SOLENOID/CIRC" with CONSULT-III or 5th judgement flicker without CONSULT-III is detected under the following conditions.

- When TCM detects an improper voltage drop when it tries to operate the solenoid valve.
- When TCM detects as irregular by comparing target value with monitor value.

### Possible Cause

INFOID:000000001327262

- Harness or connectors  
(Solenoid circuit is open or shorted.)
- Input clutch solenoid valve

### DTC Confirmation Procedure

INFOID:000000001327263

#### **CAUTION:**

**Always drive vehicle at a safe speed.**

#### **NOTE:**

**If "DTC Confirmation Procedure" has been previously performed, always turn ignition switch OFF and wait at least 10 seconds before performing the next test.**

After the repair, perform the following procedure to confirm the malfunction is eliminated.

#### Ⓜ WITH CONSULT-III

1. Turn ignition switch ON.
2. Select "SELECTION FROM MENU" in "DATA MONITOR" mode for "TRANSMISSION" with CONSULT-III and check monitor "ACCELE POSI", "SLCT LVR POSI" and "GEAR".
3. Touch "START".
4. Start engine.
5. Drive vehicle and maintain the following conditions for at least 5 consecutive seconds.  
**ACCELE POSI: 1.5/8 - 2.0/8**  
**SLCT LVR POSI: "D" position**  
**GEAR: "3" ⇒ "4" (I/C ON/OFF)**  
**Driving location: Driving the vehicle uphill (increased engine load) will help maintain the driving conditions required for this test.**
6. If DTC is detected go to [AT-143. "Diagnosis Procedure"](#).

#### Ⓜ WITH GST

Follow the procedure "WITH CONSULT-III".

### Diagnosis Procedure

INFOID:000000001327264

#### 1. CHECK INPUT SIGNAL

##### Ⓜ With CONSULT-III

1. Turn ignition switch ON.
2. Select "MAIN SIGNALS" in "DATA MONITOR" mode for "TRANSMISSION" with CONSULT-III.
3. Start the engine.

## DTC P1752 INPUT CLUTCH SOLENOID VALVE

### < SERVICE INFORMATION >

4. Read out the value of "I/C SOLENOID" while driving.

Item name	Condition	Display value (Approx.)
I/C SOLENOID	Input clutch disengaged. Refer to <a href="#">AT-18</a> .	0.6 - 0.8 A
	Input clutch engaged. Refer to <a href="#">AT-18</a> .	0 - 0.05 A

#### OK or NG

OK >> GO TO 4.

NG >> GO TO 2.

### 2. CHECK TCM POWER SUPPLY AND GROUND CIRCUIT

Check TCM power supply and ground circuit. Refer to [AT-160](#).

#### OK or NG

OK >> GO TO 3.

NG >> Repair or replace damaged parts.

### 3. DETECT MALFUNCTIONING ITEM

Check A/T assembly harness connector pin terminals for damage or loose connection with harness connector.

#### OK or NG

OK >> Replace the control valve with TCM. Refer to [AT-215, "Control Valve with TCM and A/T Fluid Temperature Sensor 2"](#).

NG >> Repair or replace damaged parts.

### 4. CHECK DTC

Perform [AT-147, "DTC Confirmation Procedure"](#).

#### OK or NG

OK >> **INSPECTION END**

NG >> GO TO 2.



# DTC P1757 FRONT BRAKE SOLENOID VALVE

< SERVICE INFORMATION >

## DTC P1757 FRONT BRAKE SOLENOID VALVE

### Description

INFOID:000000001327271

Front brake solenoid valve is controlled by the TCM in response to signals sent from the PNP switch, vehicle speed sensor and accelerator pedal position sensor (throttle position sensor). Gears will then be shifted to the optimum position.

### CONSULT-III Reference Value in Data Monitor Mode

INFOID:000000001327272

Item name	Condition	Display value (Approx.)
FR/B SOLENOID	Front brake engaged. Refer to <a href="#">AT-18</a> .	0.6 - 0.8 A
	Front brake disengaged. Refer to <a href="#">AT-18</a> .	0 - 0.05 A

### On Board Diagnosis Logic

INFOID:000000001327273

Diagnostic trouble code "P1757 FR/B SOLENOID/CIRC" with CONSULT-III or 6th judgement flicker without CONSULT-III is detected under the following conditions.

- When TCM detects an improper voltage drop when it tries to operate the solenoid valve.
- When TCM detects as irregular by comparing target value with monitor value.

### Possible Cause

INFOID:000000001327274

- Harness or connectors  
(Solenoid circuit is open or shorted.)
- Front brake solenoid valve

### DTC Confirmation Procedure

INFOID:000000001327275

#### **CAUTION:**

**Always drive vehicle at a safe speed.**

#### **NOTE:**

**If "DTC Confirmation Procedure" has been previously performed, always turn ignition switch OFF and wait at least 10 seconds before performing the next test.**

After the repair, perform the following procedure to confirm the malfunction is eliminated.

#### Ⓜ WITH CONSULT-III

1. Turn ignition switch ON.
2. Select "SELECTION FROM MENU" in "DATA MONITOR" mode for "TRANSMISSION" with CONSULT-III and check monitor "ACCELE POSI", "SLCT LVR POSI" and "GEAR".
3. Touch "START".
4. Start engine.
5. Drive vehicle and maintain the following conditions for at least 5 consecutive seconds.  
**ACCELE POSI: 1.5/8 - 2.0/8**  
**SLCT LVR POSI: "D" position**  
**GEAR: "3" ⇒ "4" (FR/B ON/OFF)**  
**Driving location: Driving the vehicle uphill (increased engine load) will help maintain the driving conditions required for this test.**
6. If DTC is detected go to [AT-145. "Diagnosis Procedure"](#).

#### Ⓜ WITH GST

Follow the procedure "WITH CONSULT-III".

### Diagnosis Procedure

INFOID:000000001327276

#### 1. CHECK INPUT SIGNAL

##### Ⓜ With CONSULT-III

1. Turn ignition switch ON.
2. Select "MAIN SIGNALS" in "DATA MONITOR" mode for "TRANSMISSION" with CONSULT-III.
3. Start engine.

## DTC P1757 FRONT BRAKE SOLENOID VALVE

### < SERVICE INFORMATION >

4. Read out the value of "FR/B SOLENOID" while driving.

Item name	Condition	Display value (Approx.)
FR/B SOLENOID	Front brake engaged. Refer to <a href="#">AT-18</a> .	0.6 - 0.8 A
	Front brake disengaged. Refer to <a href="#">AT-18</a> .	0 - 0.05 A

#### OK or NG

OK >> GO TO 4.

NG >> GO TO 2.

### 2. CHECK TCM POWER SUPPLY AND GROUND CIRCUIT

Check TCM power supply and ground circuit. Refer to [AT-160](#).

#### OK or NG

OK >> GO TO 3.

NG >> Repair or replace damaged parts.

### 3. DETECT MALFUNCTIONING ITEM

Check A/T assembly harness connector pin terminals for damage or loose connection with harness connector.

#### OK or NG

OK >> Replace the control valve with TCM. Refer to [AT-215, "Control Valve with TCM and A/T Fluid Temperature Sensor 2"](#).

NG >> Repair or replace damaged parts.

### 4. CHECK DTC

Perform [AT-106, "DTC Confirmation Procedure"](#).

#### OK or NG

OK >> **INSPECTION END**

NG >> GO TO 2.

# DTC P1762 DIRECT CLUTCH SOLENOID VALVE

< SERVICE INFORMATION >

## DTC P1762 DIRECT CLUTCH SOLENOID VALVE

### Description

INFOID:000000001327283

Direct clutch solenoid valve is controlled by the TCM in response to signals sent from the PNP switch, vehicle speed sensor and accelerator pedal position sensor (throttle position sensor). Gears will then be shifted to the optimum position.

### CONSULT-III Reference Value in Data Monitor Mode

INFOID:000000001327284

Item name	Condition	Display value (Approx.)
D/C SOLENOID	Direct clutch disengaged. Refer to <a href="#">AT-18</a> .	0.6 - 0.8 A
	Direct clutch engaged. Refer to <a href="#">AT-18</a> .	0 - 0.05 A

### On Board Diagnosis Logic

INFOID:000000001327285

Diagnostic trouble code "P1762 D/C SOLENOID/CIRC" with CONSULT-III or 2nd judgement flicker without CONSULT-III is detected under the following conditions.

- When TCM detects an improper voltage drop when it tries to operate the solenoid valve.
- When TCM detects as irregular by comparing target value with monitor value.

### Possible Cause

INFOID:000000001327286

- Harness or connectors  
(Solenoid circuit is open or shorted.)
- Direct clutch solenoid valve

### DTC Confirmation Procedure

INFOID:000000001327287

#### **CAUTION:**

**Always drive vehicle at a safe speed.**

#### **NOTE:**

**If "DTC Confirmation Procedure" has been previously performed, always turn ignition switch OFF and wait at least 10 seconds before performing the next test.**

After the repair, perform the following procedure to confirm the malfunction is eliminated.

#### Ⓜ WITH CONSULT-III

1. Turn ignition switch ON.
2. Select "SELECTION FROM MENU" in "DATA MONITOR" mode for "TRANSMISSION" with CONSULT-III and check monitor "ACCELE POSI", "SLCT LVR POSI" and "GEAR".
3. Touch "START".
4. Start engine.
5. Drive vehicle and maintain the following conditions for at least 5 consecutive seconds.  
**ACCELE POSI: 1.5/8 - 2.0/8**  
**SLCT LVR POSI: "D" position**  
**GEAR: "1" ⇒ "2" (D/C ON/OFF)**  
**Driving location: Driving the vehicle uphill (increased engine load) will help maintain the driving conditions required for this test.**
6. If DTC is detected, go to [AT-147, "Diagnosis Procedure"](#).

#### Ⓜ WITH GST

Follow the procedure "WITH CONSULT-III".

### Diagnosis Procedure

INFOID:000000001327288

#### 1. CHECK INPUT SIGNAL

##### Ⓜ With CONSULT-III

1. Turn ignition switch ON.
2. Select "MAIN SIGNALS" in "DATA MONITOR" mode for "TRANSMISSION" with CONSULT-III.
3. Start the engine.

# DTC P1762 DIRECT CLUTCH SOLENOID VALVE

## < SERVICE INFORMATION >

4. Read out the value of "D/C SOLENOID" while driving.

Item name	Condition	Display value (Approx.)
D/C SOLENOID	Direct clutch disengaged. Refer to <a href="#">AT-18</a> .	0.6 - 0.8 A
	Direct clutch engaged. Refer to <a href="#">AT-18</a> .	0 - 0.05 A

### OK or NG

OK >> GO TO 4.

NG >> GO TO 2.

## 2. CHECK TCM POWER SUPPLY AND GROUND CIRCUIT

Check TCM power supply and ground circuit. Refer to [AT-160](#).

### OK or NG

OK >> GO TO 3.

NG >> Repair or replace damaged parts.

## 3. DETECT MALFUNCTIONING ITEM

Check A/T assembly harness connector pin terminals for damage or loose connection with harness connector.

### OK or NG

OK >> Replace the control valve with TCM. Refer to [AT-215, "Control Valve with TCM and A/T Fluid Temperature Sensor 2"](#).

NG >> Repair or replace damaged parts.

## 4. CHECK DTC

Perform [AT-147, "DTC Confirmation Procedure"](#).

### OK or NG

OK >> **INSPECTION END**

NG >> GO TO 2.

# DTC P1767 HIGH AND LOW REVERSE CLUTCH SOLENOID VALVE

< SERVICE INFORMATION >

## DTC P1767 HIGH AND LOW REVERSE CLUTCH SOLENOID VALVE

### Description

INFOID:000000001327295

High and low reverse clutch solenoid valve is controlled by the TCM in response to signals sent from the PNP switch, vehicle speed sensor and accelerator pedal position sensor (throttle position sensor). Gears will then be shifted to the optimum position.

### CONSULT-III Reference Value in Data Monitor Mode

INFOID:000000001327296

Item name	Condition	Display value (Approx.)
HLR/C SOL	High and low reverse clutch disengaged. Refer to <a href="#">AT-18</a> .	0.6 - 0.8 A
	High and low reverse clutch engaged. Refer to <a href="#">AT-18</a> .	0 - 0.05 A

### On Board Diagnosis Logic

INFOID:000000001327297

Diagnostic trouble code "P1767 HLR/C SOL/CIRC" with CONSULT-III or 8th judgement flicker without CONSULT-III is detected under the following conditions.

- When TCM detects an improper voltage drop when it tries to operate the solenoid valve.
- When TCM detects as irregular by comparing target value with monitor value.

### Possible Cause

INFOID:000000001327298

- Harness or connectors  
(Solenoid circuit is open or shorted.)
- High and low reverse clutch solenoid valve

### DTC Confirmation Procedure

INFOID:000000001327299

#### **CAUTION:**

**Always drive vehicle at a safe speed.**

#### **NOTE:**

**If "DTC Confirmation Procedure" has been previously performed, always turn ignition switch OFF and wait at least 10 seconds before performing the next test.**

After the repair, perform the following procedure to confirm the malfunction is eliminated.

#### Ⓜ WITH CONSULT-III

1. Turn ignition switch ON.
2. Select "SELECTION FROM MENU" in "DATA MONITOR" mode for "TRANSMISSION" with CONSULT-III and check monitor "ACCELE POSI", "SLCT LVR POSI" and "GEAR".
3. Touch "START".
4. Start engine.
5. Drive vehicle and maintain the following conditions for at least 5 consecutive seconds.  
**ACCELE POSI: 1.5/8 - 2.0/8**  
**SLCT LVR POSI: "D" position**  
**GEAR: "2" ⇒ "3" (HLR/C ON/OFF)**  
**Driving location: Driving the vehicle uphill (increased engine load) will help maintain the driving conditions required for this test.**
6. If DTC is detected, go to [AT-149, "Diagnosis Procedure"](#).

#### Ⓜ WITH GST

Follow the procedure "WITH CONSULT-III".

### Diagnosis Procedure

INFOID:000000001327300

#### 1. CHECK INPUT SIGNAL

##### Ⓜ With CONSULT-III

1. Turn ignition switch ON.
2. Select "MAIN SIGNALS" in "DATA MONITOR" mode for "TRANSMISSION" with CONSULT-III.
3. Start the engine.

# DTC P1767 HIGH AND LOW REVERSE CLUTCH SOLENOID VALVE

## < SERVICE INFORMATION >

4. Read out the value of "HLR/C SOLENOID" while driving.

Item name	Condition	Display value (Approx.)
HLR/C SOL	High and low reverse clutch disengaged. Refer to <a href="#">AT-18</a> .	0.6 - 0.8 A
	High and low reverse clutch engaged. Refer to <a href="#">AT-18</a> .	0 - 0.05 A

### OK or NG

- OK >> GO TO 4.
- NG >> GO TO 2.

## **2.**CHECK TCM POWER SUPPLY AND GROUND CIRCUIT

Check TCM power supply and ground circuit. Refer to [AT-160](#).

### OK or NG

- OK >> GO TO 3.
- NG >> Repair or replace damaged parts.

## **3.**DETECT MALFUNCTIONING ITEM

Check A/T assembly harness connector pin terminals for damage or loose connection with harness connector.

### OK or NG

- OK >> Replace the control valve with TCM. Refer to [AT-215, "Control Valve with TCM and A/T Fluid Temperature Sensor 2"](#).
- NG >> Repair or replace damaged parts.

## **4.**CHECK DTC

Perform [AT-149, "DTC Confirmation Procedure"](#).

### OK or NG

- OK >> **INSPECTION END**
- NG >> GO TO 2.

# DTC P1772 LOW COAST BRAKE SOLENOID VALVE

< SERVICE INFORMATION >

## DTC P1772 LOW COAST BRAKE SOLENOID VALVE

### Description

INFOID:000000001327307

Low coast brake solenoid valve is turned ON or OFF by the TCM in response to signals sent from the PNP switch, vehicle speed sensor and accelerator pedal position sensor (throttle position sensor). Gears will then be shifted to the optimum position.

### CONSULT-III Reference Value in Data Monitor Mode

INFOID:000000001327308

Item name	Condition	Display value
ON OFF SOL	Low coast brake engaged. Refer to <a href="#">AT-18</a> .	ON
	Low coast brake disengaged. Refer to <a href="#">AT-18</a> .	OFF

### On Board Diagnosis Logic

INFOID:000000001327309

Diagnostic trouble code "P1772 LC/B SOLENOID/CIRC" with CONSULT-III or 7th judgement flicker without CONSULT-III is detected when TCM detects an improper voltage drop when it tries to operate the solenoid valve.

### Possible Cause

INFOID:000000001327310

- Harness or connectors  
(Solenoid circuit is open or shorted.)
- Low coast brake solenoid valve

### DTC Confirmation Procedure

INFOID:000000001327311

#### NOTE:

If "DTC Confirmation Procedure" has been previously performed, always turn ignition switch OFF and wait at least 10 seconds before performing the next test.

After the repair, perform the following procedure to confirm the malfunction is eliminated.

#### Ⓜ WITH CONSULT-III

1. Turn ignition switch ON.
2. Select "SELECTION FROM MENU" in "DATA MONITOR" mode for "TRANSMISSION" with CONSULT-III and check monitor "MANU MODE SW" and "GEAR".
3. Touch "START".
4. Start engine.
5. Drive vehicle and maintain the following conditions for at least 5 consecutive seconds.  
**MANU MODE SW: ON**  
**GEAR: "1" or "2" (LC/B ON/OFF)**
6. If DTC is detected, go to [AT-151](#). "Diagnosis Procedure".

#### Ⓜ WITH GST

Follow the procedure "WITH CONSULT-III".

### Diagnosis Procedure

INFOID:000000001327312

#### 1. CHECK INPUT SIGNAL

##### Ⓜ With CONSULT-III

1. Turn ignition switch ON.
2. Select "SELECTION FROM MENU" in "DATA MONITOR" mode for "TRANSMISSION" with CONSULT-III.
3. Start engine.
4. Read out the value of "ON OFF SOL" while driving.

Item name	Condition	Display value
ON OFF SOL	Low coast brake engaged. Refer to <a href="#">AT-18</a> .	ON
	Low coast brake disengaged. Refer to <a href="#">AT-18</a> .	OFF

## DTC P1772 LOW COAST BRAKE SOLENOID VALVE

< SERVICE INFORMATION >

---

OK or NG

OK >> GO TO 4.  
NG >> GO TO 2.

### 2. CHECK TCM POWER SUPPLY AND GROUND CIRCUIT

---

Check TCM power supply and ground circuit. Refer to [AT-160](#).

OK or NG

OK >> GO TO 3.  
NG >> Repair or replace damaged parts.

### 3. DETECT MALFUNCTIONING ITEM

---

Check A/T assembly harness connector pin terminals for damage or loose connection with harness connector.

OK or NG

OK >> Replace the control valve with TCM. Refer to [AT-215, "Control Valve with TCM and A/T Fluid Temperature Sensor 2"](#).  
NG >> Repair or replace damaged parts.

### 4. CHECK DTC

---

Perform [AT-151, "DTC Confirmation Procedure"](#).

OK or NG

OK >> **INSPECTION END**  
NG >> GO TO 2.



# DTC P1774 LOW COAST BRAKE SOLENOID VALVE FUNCTION

< SERVICE INFORMATION >

## DTC P1774 LOW COAST BRAKE SOLENOID VALVE FUNCTION

### Description

INFOID:000000001327313

- Low coast brake solenoid valve is turned ON or OFF by the TCM in response to signals sent from the PNP switch, vehicle speed sensor and accelerator pedal position sensor (throttle position sensor). Gears will then be shifted to the optimum position.
- This is not only caused by electrical malfunction (circuits open or shorted) but also by mechanical malfunction such as control valve sticking, improper solenoid valve operation.

### CONSULT-III Reference Value in Data Monitor Mode

INFOID:000000001327314

Item name	Condition	Display value
ON OFF SOL	Low coast brake engaged. Refer to <a href="#">AT-18</a> .	ON
	Low coast brake disengaged. Refer to <a href="#">AT-18</a> .	OFF
ATF PRES SW 2	Low coast brake engaged. Refer to <a href="#">AT-18</a> .	ON
	Low coast brake disengaged. Refer to <a href="#">AT-18</a> .	OFF

### On Board Diagnosis Logic

INFOID:000000001327315

Diagnostic trouble code "P1774 LC/B SOLENOID FNCT" with CONSULT-III or 7th judgement flicker without CONSULT-III is detected under the following conditions.

- When TCM detects that actual gear ratio is irregular, and relation between gear position and condition of ATF pressure switch 2 is irregular during depressing accelerator pedal. (Other than during shift change)
- When TCM detects that relation between gear position and condition of ATF pressure switch 2 is irregular during releasing accelerator pedal. (Other than during shift change)

### Possible Cause

INFOID:000000001327316

- Harness or connectors  
(Solenoid and switch circuits are open or shorted.)
- Low coast brake solenoid valve
- ATF pressure switch 2

### DTC Confirmation Procedure

INFOID:000000001327317

#### **CAUTION:**

**Always drive vehicle at a safe speed.**

#### **NOTE:**

**If "DTC Confirmation Procedure" has been previously performed, always turn ignition switch OFF and wait at least 10 seconds before performing the next test.**

After the repair, perform the following procedure to confirm the malfunction is eliminated.

#### WITH CONSULT-III

1. Start engine.
2. Accelerate vehicle to maintain the following conditions.  
**MANU MODE SW: ON**  
**GEAR: "1" or "2" (LC/B ON/OFF)**
3. Perform step "2" again.
4. Turn ignition switch OFF, then perform step "1" to "3" again.
5. Check "SELF-DIAG RESULTS" mode for "TRANSMISSION" with CONSULT-III. If DTC (P1774) is detected, go to [AT-153. "Diagnosis Procedure"](#).  
If DTC (P1772) is detected, go to [AT-151. "Diagnosis Procedure"](#).

#### WITH GST

Follow the procedure "WITH CONSULT-III".

### Diagnosis Procedure

INFOID:000000001327318

#### 1. CHECK INPUT SIGNALS

# DTC P1774 LOW COAST BRAKE SOLENOID VALVE FUNCTION

## < SERVICE INFORMATION >

### ④ With CONSULT-III

1. Start engine.
2. Select "SELECTION FROM MENU" in "DATA MONITOR" mode for "TRANSMISSION" with CONSULT-III.
3. Drive vehicle in the manual mode (1st or 2nd gear), and confirm the ON/OFF actuation of the "ATF PRES SW 2" and "ON OFF SOL".

Item name	Condition	Display value
ON OFF SOL	Low coast brake engaged. Refer to <a href="#">AT-18</a> .	ON
	Low coast brake disengaged. Refer to <a href="#">AT-18</a> .	OFF
ATF PRES SW 2	Low coast brake engaged. Refer to <a href="#">AT-18</a> .	ON
	Low coast brake disengaged. Refer to <a href="#">AT-18</a> .	OFF

### OK or NG

- OK >> GO TO 4.  
NG >> GO TO 2.

## 2. CHECK TCM POWER SUPPLY AND GROUND CIRCUIT

Check TCM power supply and ground circuit. Refer to [AT-160](#).

### OK or NG

- OK >> GO TO 3.  
NG >> Repair or replace damaged parts.

## 3. DETECT MALFUNCTIONING ITEM

Check A/T assembly harness connector pin terminals for damage or loose connection with harness connector.

### OK or NG

- OK >> Replace the control valve with TCM. Refer to [AT-215, "Control Valve with TCM and A/T Fluid Temperature Sensor 2"](#).  
NG >> Repair or replace damaged parts.

## 4. CHECK DTC

Perform [AT-153, "DTC Confirmation Procedure"](#).

### OK or NG

- OK >> **INSPECTION END**  
NG >> GO TO 2.

# DTC P1815 MANUAL MODE SWITCH

< SERVICE INFORMATION >

## DTC P1815 MANUAL MODE SWITCH

### Description

INFOID:000000001327319

Manual mode switch is installed in A/T device. It sends manual mode switch, shift up and shift down switch signals to TCM.

TCM sends the switch signals to unified meter and A/C amp. by CAN communication line. Then manual mode switch position is indicated on the A/T indicator. For inspection, refer to [AT-166](#).

### CONSULT-III Reference Value in Data Monitor Mode

INFOID:000000001327320

Item name	Condition	Display Value
MANU MODE SW	Manual shift gate position (neutral)	ON
	Other than the above	OFF
NON M-MODE SW	Manual shift gate position	OFF
	Other than the above	ON
UP SW LEVER	selector lever: + side	ON
	Other than the above	OFF
DOWN SW LEVER	selector lever: - side	ON
	Other than the above	OFF

### On Board Diagnosis Logic

INFOID:000000001327321

Diagnostic trouble code "P1815 MANU MODE SW/CIR" with CONSULT-III is detected when TCM monitors Manual mode, Non manual mode, Up or Down switch signal, and detects as irregular when impossible input pattern occurs 1 second or more.

### Possible Cause

INFOID:000000001327322

- Harness or connectors  
(These switches circuit is open or shorted.)
- Manual mode select switch (Into control device)
- Manual mode position select switch (Into control device)

### DTC Confirmation Procedure

INFOID:000000001327323

#### NOTE:

If "DTC Confirmation Procedure" has been previously performed, always turn ignition switch OFF and wait at least 10 seconds before performing the next test.

After the repair, perform the following procedure to confirm the malfunction is eliminated.

#### ④ WITH CONSULT-III

1. Turn ignition switch ON.
2. Select "ECU INPUT SIGNALS" in "DATA MONITOR" mode for "TRANSMISSION" with CONSULT-III.
3. Start engine.
4. Drive vehicle and maintain the following conditions for at least 2 consecutive seconds.  
**MANU MODE SW: ON**
5. If DTC is detected, go to [AT-158, "Diagnosis Procedure"](#).

# DTC P1815 MANUAL MODE SWITCH

< SERVICE INFORMATION >

## Wiring Diagram - AT - MMSW

INFOID:000000001327324

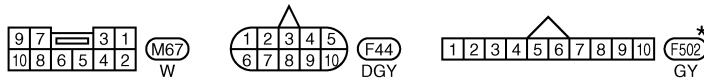
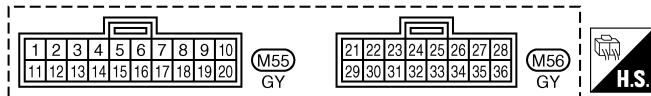
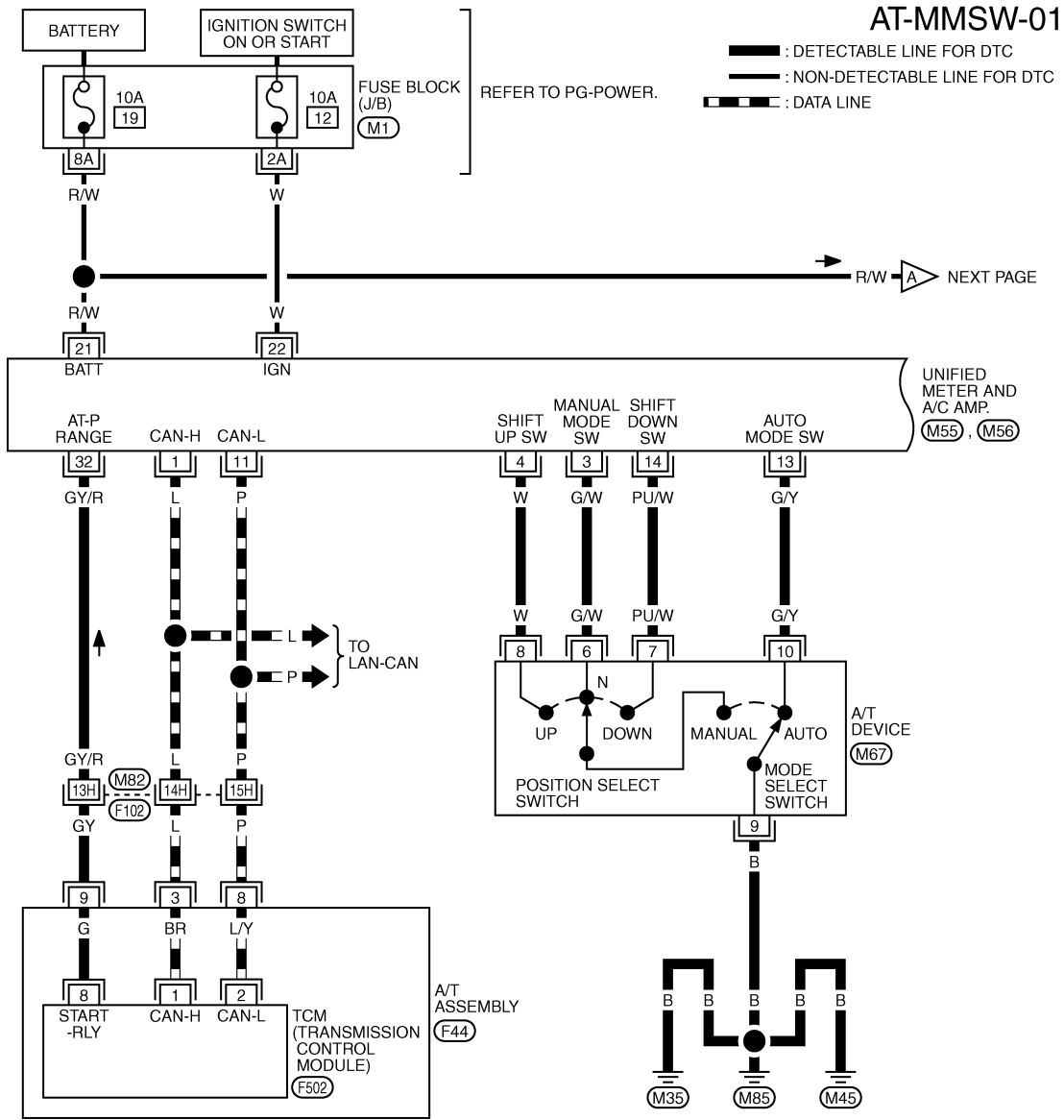

\*: THIS CONNECTOR IS NOT SHOWN IN "HARNESS LAYOUT", PG SECTION.

REFER TO THE FOLLOWING.

- (F102) -SUPER MULTIPLE JUNCTION (SMJ)
- (M1) -FUSE BLOCK-JUNCTION BOX (J/B)

TCWM0498E

# DTC P1815 MANUAL MODE SWITCH

< SERVICE INFORMATION >

AT-MMSW-02

— : DETECTABLE LINE FOR DTC  
 - - - : NON-DETECTABLE LINE FOR DTC

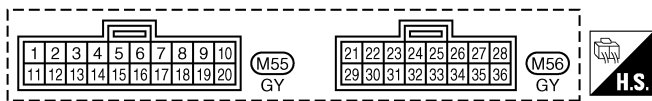
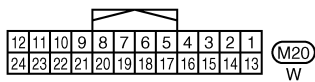
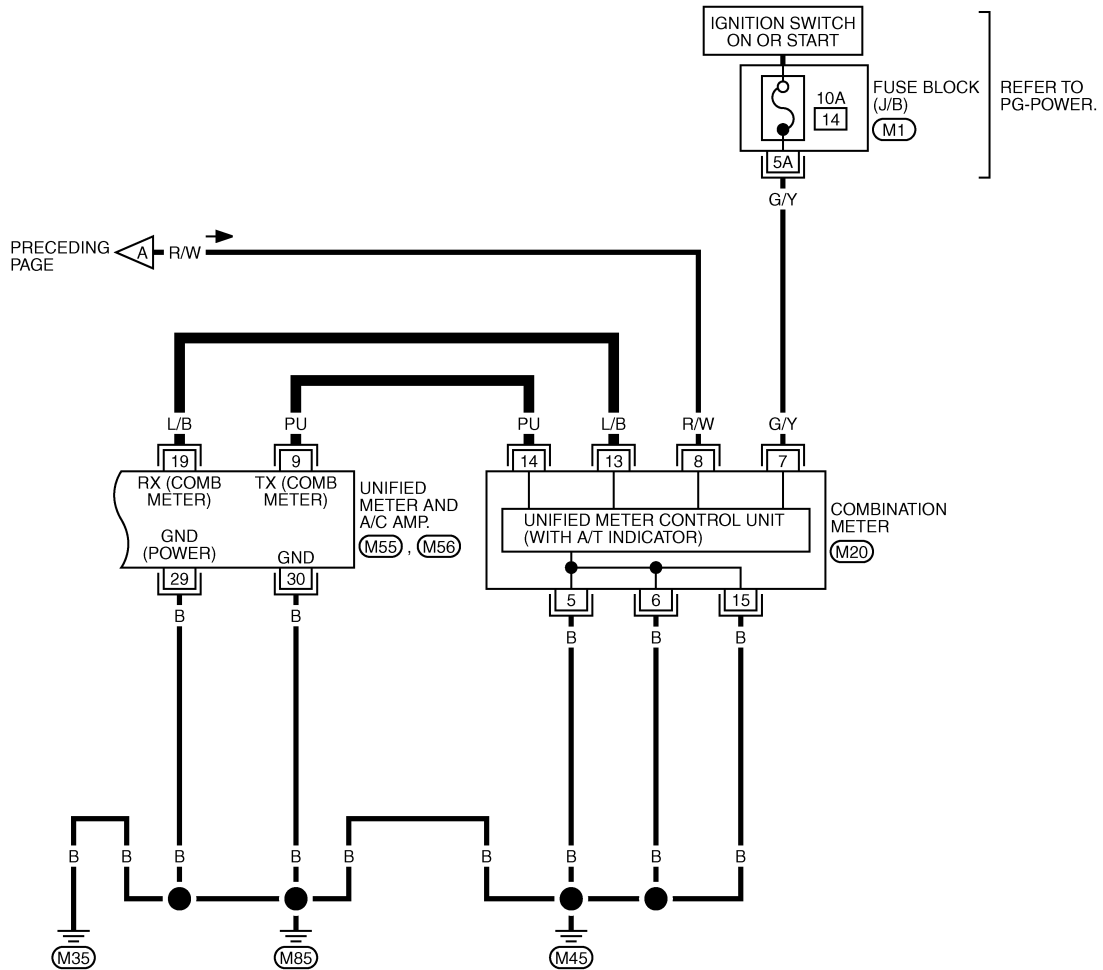

REFER TO THE FOLLOWING.  
 (M1) - FUSE BLOCK-JUNCTION BOX (J/B)

TCM terminals and data are reference value. Measured between each terminal and ground.

TCWM0499E

Terminal	Wire color	Item	Condition	Data (Approx.)
3	L	CAN-H	-	-
8	P	CAN-L	-	-

# DTC P1815 MANUAL MODE SWITCH

## < SERVICE INFORMATION >

Terminal	Wire color	Item	Condition	Data (Approx.)
9	GY	Starter relay	 Selector lever in "N" and "P" positions.	Battery voltage
			Selector lever in other positions.	0 V

## Diagnosis Procedure

INFOID:000000001327325

### 1. CHECK CAN COMMUNICATION LINE

Perform the self-diagnosis.

Is a malfunction in the CAN communication indicated in the results?

- YES >> Check CAN communication line. Refer to [AT-94](#).  
 NO >> GO TO 2.

### 2. CHECK MANUAL MODE SWITCH CIRCUIT

#### With CONSULT-III

- Turn ignition switch ON.
- Select "ECU INPUT SIGNALS" in "DATA MONITOR" mode for "TRANSMISSION" with CONSULT-III.
- Read out ON/OFF switching action of "MANU MODE SW", "NON M-MODE SW", "UP SW LEVER", "DOWN SW LEVER".

Item name	Condition	Display Value
MANU MODE SW	Manual shift gate position (neutral)	ON
	Other than the above	OFF
NON M-MODE SW	Manual shift gate position	OFF
	Other than the above	ON
UP SW LEVER	selector lever: +side	ON
	Other than the above	OFF
DOWN SW LEVER	selector lever: -side	ON
	Other than the above	OFF

#### Without CONSULT-III

Drive vehicle in the manual mode, and confirm that the actual gear position and the meter's indication of the position mutually coincide when the selector lever is shifted to the "+" (up) or "-" (down) side (1st ⇔ 5th gear).

OK or NG

- OK >> GO TO 4.  
 NG >> GO TO 3.

### 3. DETECT MALFUNCTIONING ITEM

Check the following.

- Manual mode switch. Refer to [AT-159, "Component Inspection"](#).
- Pin terminals for damage or loose connection with harness connector.
- Open circuit or short to ground or short to power in harness or connector for A/T device (manual mode switch).
- Unified meter and A/C amp. Refer to [DI-5](#).

OK or NG

- OK >> GO TO 4.  
 NG >> Repair or replace damaged parts.

### 4. CHECK DTC

Perform [AT-155, "DTC Confirmation Procedure"](#).

OK or NG

- OK >> **INSPECTION END**  
 NG >> GO TO 5.

# DTC P1815 MANUAL MODE SWITCH

## < SERVICE INFORMATION >

### 5. CHECK TCM POWER SUPPLY AND GROUND CIRCUIT

Check TCM power supply and ground circuit. Refer to [AT-160](#).

OK or NG

OK >> GO TO 6.

NG >> Repair or replace damaged parts.

### 6. DETECT MALFUNCTIONING ITEM

Check A/T assembly harness connector pin terminals for damage or loose connection with harness connector.

OK or NG

OK >> Replace the control valve with TCM. Refer to [AT-215](#), "Control Valve with TCM and A/T Fluid Temperature Sensor 2".

NG >> Repair or replace damaged parts.

## Component Inspection

INFOID:000000001327326

### MANUAL MODE SWITCH

Check continuity between terminals.

Item	Position	Connector	Terminal	Continuity
Manual mode select switch	Auto	M67	9 - 10	Yes
	Manual		6 - 9	
Manual mode position select switch	UP		8 - 9	
	DOWN		7 - 9	

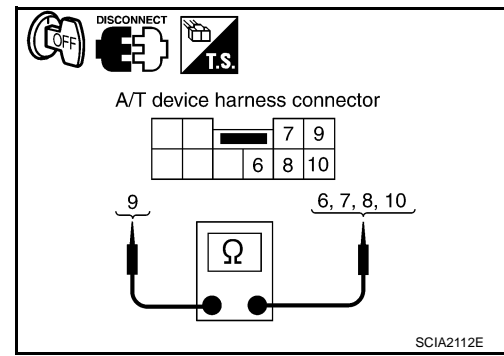

# MAIN POWER SUPPLY AND GROUND CIRCUIT

< SERVICE INFORMATION >

## MAIN POWER SUPPLY AND GROUND CIRCUIT

Wiring Diagram - AT - MAIN

INFOID:000000001327351

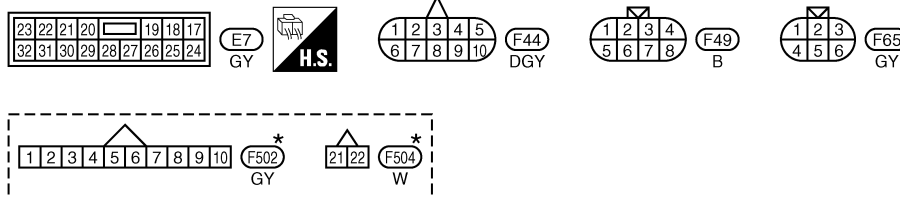
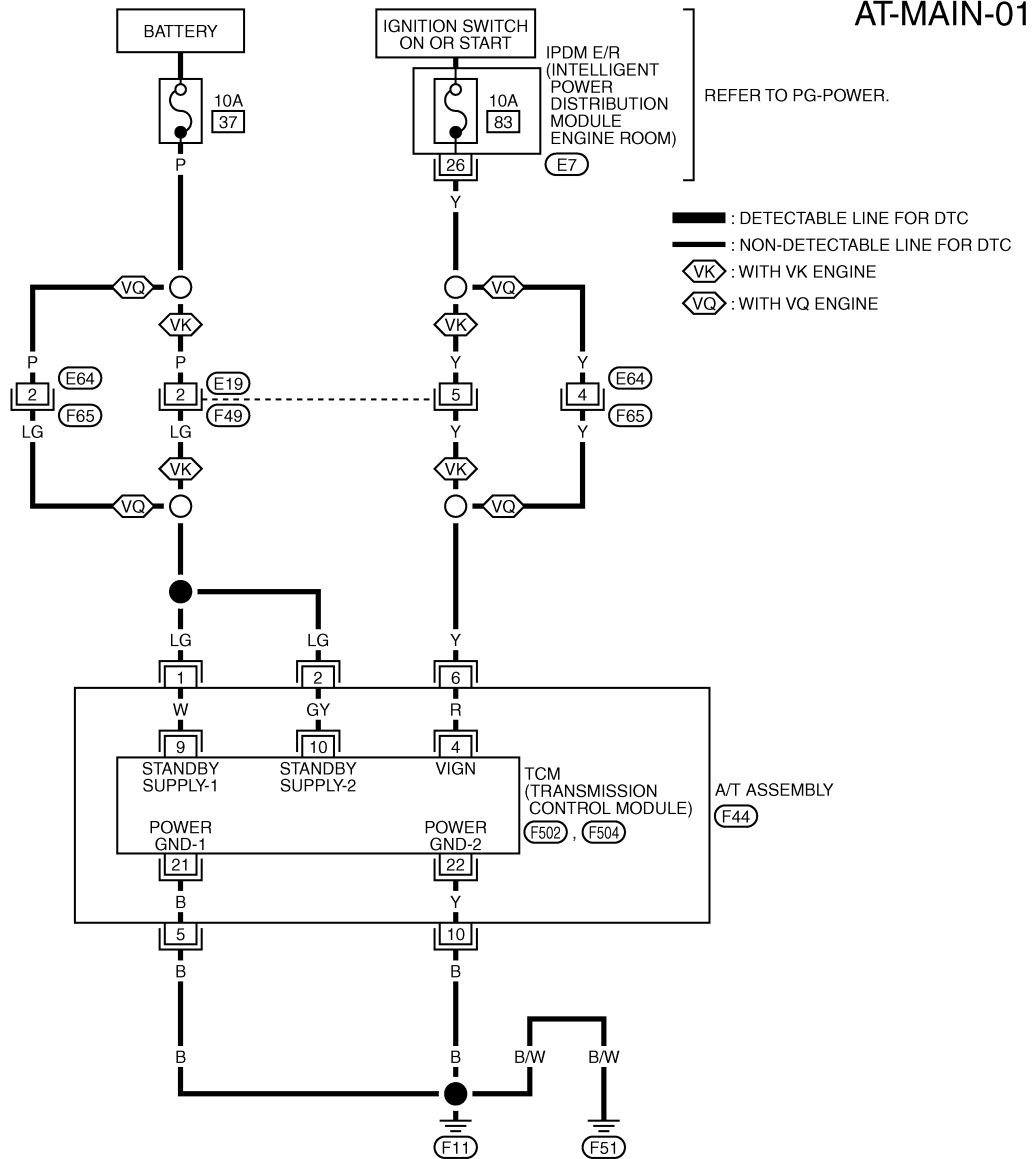

\*: THIS CONNECTOR IS NOT SHOWN IN "HARNESS LAYOUT", PG SECTION.



TCWM0497E



# MAIN POWER SUPPLY AND GROUND CIRCUIT

## < SERVICE INFORMATION >

TCM terminals and data are reference value. Measured between each terminal and ground.

Terminal	Wire color	Item	Condition	Data (Approx.)
1	LG	Power supply (Memory back-up)	Always	Battery voltage
2	LG	Power supply (Memory back-up)	Always	Battery voltage
5	B	Ground	Always	0 V
6	Y	Power supply		Battery voltage
				0 V
10	B	Ground	Always	0 V

## Diagnosis Procedure

INFOID:000000001327352

### 1. CHECK TCM POWER SOURCE STEP 1

- Turn ignition switch OFF.
- Disconnect A/T assembly harness connector.
- Check voltage between A/T assembly harness connector terminals and ground.

Item	Connector	Terminal	Voltage
TCM	F44	1 - Ground	Battery voltage
		2 - Ground	
		6 - Ground	0 V

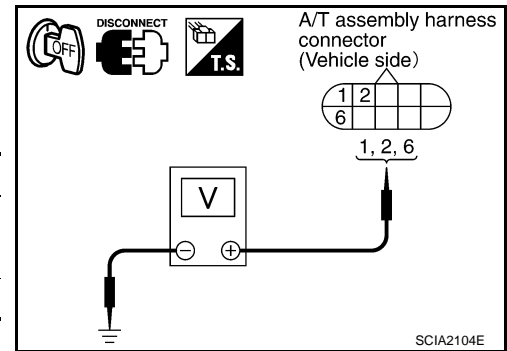

#### OK or NG

- OK >> GO TO 2.
- NG >> GO TO 3.

### 2. CHECK TCM POWER SOURCE STEP 2

- Disconnect A/T assembly harness connector.
- Turn ignition switch ON.
- Check voltage between A/T assembly harness connector terminals and ground.

Item	Connector	Terminal	Voltage
TCM	F44	1 - Ground	Battery voltage
		2 - Ground	
		6 - Ground	0 V

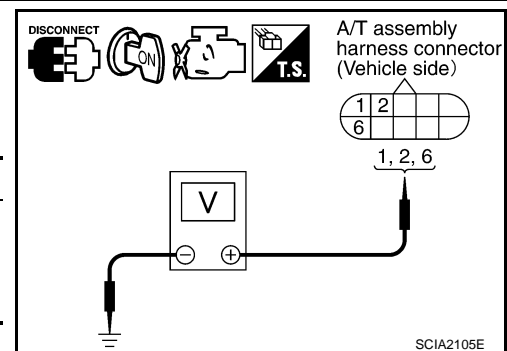

#### OK or NG

- OK >> GO TO 4.
- NG >> GO TO 3.

### 3. DETECT MALFUNCTIONING ITEM

Check the following.

- Harness for short or open between battery and A/T assembly harness connector F44 terminals 1, 2
- Harness for short or open between ignition switch and A/T assembly harness connector F44 terminal 6
- 10 A fuse (No. 37, located in the fuse and fusible link block) and 10 A fuse (No. 83, located in the IPDM E/R)
- Ignition switch, Refer to [PG-3](#).

#### OK or NG

- OK >> GO TO 4.

# MAIN POWER SUPPLY AND GROUND CIRCUIT

## < SERVICE INFORMATION >

NG >> Repair or replace damaged parts.

### 4. CHECK TCM GROUND CIRCUIT

1. Turn ignition switch OFF.
2. Disconnect A/T assembly harness connector.
3. Check continuity between A/T assembly harness connector F44 terminals and ground.

**Continuity should exist.**

If OK, check harness for short to ground and short to power.

#### OK or NG

OK >> GO TO 5.

NG >> Repair open circuit or short to ground or short to power in harness or connectors.

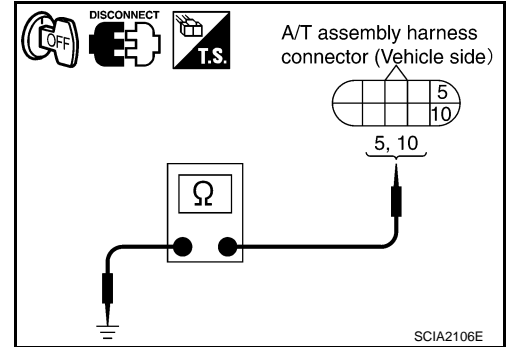

### 5. DETECT MALFUNCTIONING ITEM

Check A/T assembly harness connector pin terminals for damage or loose connection with harness connector.

#### OK or NG

OK >> GO TO 6.

NG >> Repair or replace damaged parts.

### 6. PERFORM SELF-DIAGNOSIS

Perform self-diagnosis.

#### OK or NG

OK >> **INSPECTION END**

NG-1 >> Self-diagnosis does not activate: GO TO 7.

NG-2 >> DTC is displayed: Check the malfunctioning system. Refer to [AT-84, "CONSULT-III Function \(TRANSMISSION\)"](#).

### 7. CHECK TERMINAL CORD ASSEMBLY

1. Remove control valve with TCM. Refer to [AT-215, "Control Valve with TCM and A/T Fluid Temperature Sensor 2"](#).
2. Disconnect A/T assembly harness connector and TCM connector.
3. Check continuity between A/T assembly harness connector terminals and TCM connector terminals.

Item	Connector	Terminal	Continuity
A/T assembly harness connector	F44	1	Yes
TCM connector	F502	9	
A/T assembly harness connector	F44	2	Yes
TCM connector	F502	10	
A/T assembly harness connector	F44	6	Yes
TCM connector	F502	4	

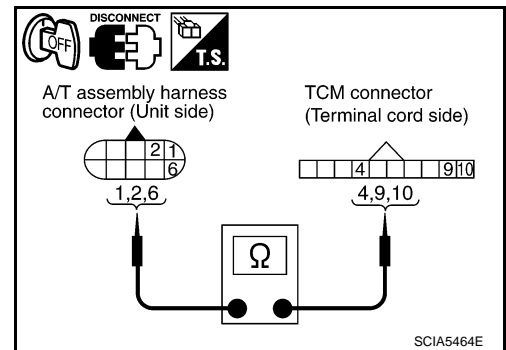

# MAIN POWER SUPPLY AND GROUND CIRCUIT

## < SERVICE INFORMATION >

4. Check continuity between A/T assembly harness connector terminals and TCM connector terminals.

Item	Connector	Terminal	Continuity
A/T assembly harness connector	F44	5	Yes
TCM connector	F504	21	
A/T assembly harness connector	F44	10	Yes
TCM connector	F504	22	

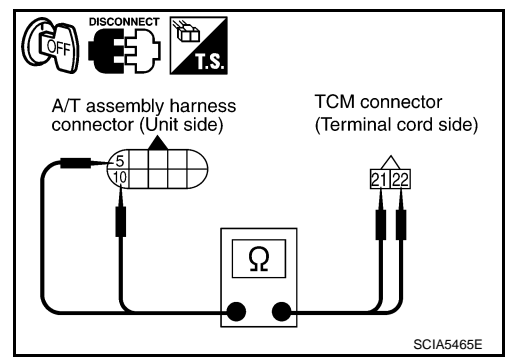

5. If OK, check harness for short to ground and short to power.

### OK or NG

- OK >> Replace the control valve with TCM. Refer to [AT-215, "Control Valve with TCM and A/T Fluid Temperature Sensor 2"](#).
- NG >> Replace open circuit or short to ground and short to power in harness or connectors.

A  
B  
AT  
D  
E  
F  
G  
H  
I  
J  
K  
L  
M  
N  
O  
P

# CLOSED THROTTLE POSITION AND WIDE OPEN THROTTLE POSITION CIRCUIT

< SERVICE INFORMATION >

## CLOSED THROTTLE POSITION AND WIDE OPEN THROTTLE POSITION CIRCUIT

CONSULT-III Reference Value in Data Monitor Mode

INFOID:000000001327353

Item name	Condition	Display value
CLSD THL POS	Released accelerator pedal.	ON
	Fully depressed accelerator pedal.	OFF
W/O THL POS	Fully depressed accelerator pedal.	ON
	Released accelerator pedal.	OFF

### Diagnosis Procedure

INFOID:000000001327354

#### 1. CHECK CAN COMMUNICATION LINE

**With CONSULT-III**

- Perform the self-diagnosis.

**Without CONSULT-III**

- Perform the self-diagnosis. Refer to [AT-91, "Diagnosis Procedure without CONSULT-III"](#).

Is a malfunction in the CAN communication indicated in the results?

- YES >> Check CAN communication line. Refer to [AT-94](#).  
 NO >> GO TO 2.

#### 2. CHECK THROTTLE POSITION SIGNAL CIRCUIT

**With CONSULT-III**

1. Turn ignition switch ON.
2. Select "ECU INPUT SIGNALS" in "DATA MONITOR" mode for "TRANSMISSION" with CONSULT-III.
3. Depress accelerator pedal and read out the value of "CLSD THL POS" and "W/O THL POS".

Accelerator Pedal Operation	Monitor Item	
	CLSD THL POS	W/O THL POS
Released	ON	OFF
Fully depressed	OFF	ON

**OK or NG**

OK >> **INSPECTION END**

- NG >> Check the following items. If NG, repair or replace damaged parts.
- Perform the self-diagnosis for "ENGINE" with CONSULT-III. Refer to [EC-117, "CONSULT-III Function \(ENGINE\)"](#)(for VQ35DE) or [EC-695, "CONSULT-III Function \(ENGINE\)"](#)(for VK45DE).
  - Open circuit or short to ground or short to power in harness or connectors.
  - Pin terminals for damage or loose connection with harness connector.

# BRAKE SIGNAL CIRCUIT

< SERVICE INFORMATION >

## BRAKE SIGNAL CIRCUIT

CONSULT-III Reference Value in Data Monitor Mode

INFOID:000000001327355

Item name	Condition	Display value
BRAKE SW	Depressed brake pedal.	ON
	Released brake pedal.	OFF

### Diagnosis Procedure

INFOID:000000001327356

#### 1. CHECK CAN COMMUNICATION LINE

##### With CONSULT-III

- Perform the self-diagnosis.

##### Without CONSULT-III

- Perform the self-diagnosis. Refer to [AT-91, "Diagnosis Procedure without CONSULT-III"](#).

Is a malfunction in the CAN communication indicated in the results?

YES >> Check CAN communication line. Refer to [AT-94](#).

NO >> GO TO 2.

#### 2. CHECK STOP LAMP SWITCH CIRCUIT

##### With CONSULT-III

- Turn ignition switch ON.
- Select "ECU INPUT SIGNALS" in "DATA MONITOR" mode for "TRANSMISSION" with CONSULT-III.
- Read out ON/OFF switching action of the "BRAKE SW".

Item name	Condition	Display value
BRAKE SW	Depressed brake pedal.	ON
	Released brake pedal.	OFF

##### OK or NG

OK >> **INSPECTION END**

NG >> GO TO 3.

#### 3. CHECK STOP LAMP SWITCH

Check continuity between stop lamp switch harness connector E210 terminals 1 and 2. Refer to [AT-167, "Wiring Diagram - AT - NON-DTC"](#).

Condition	Continuity
When brake pedal is depressed	Yes
When brake pedal is released	No

**Check stop lamp switch after adjusting brake pedal — refer to [BR-5](#).**

##### OK or NG

OK >> Check the following items. If NG, repair or replace damaged parts.

- Harness for short or open between battery and stop lamp switch.
- Harness for short or open between stop lamp switch and unified meter and A/C amp.

NG >> Repair or replace the stop lamp switch.

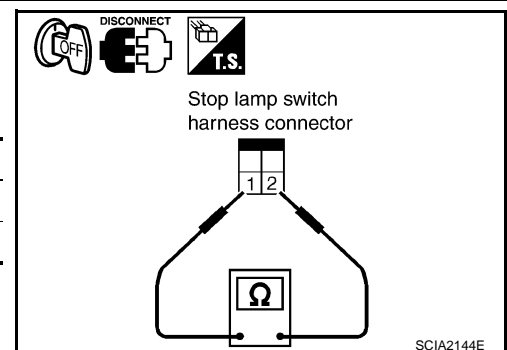

# A/T INDICATOR CIRCUIT

< SERVICE INFORMATION >

## A/T INDICATOR CIRCUIT

### Description

INFOID:000000001327357

TCM sends the switch signals to unified meter and A/C amp. by CAN communication line. Then manual mode switch position is indicated on the A/T indicator.

### CONSULT-III Reference Value in Data Monitor Mode

INFOID:000000001327358

Item name	Condition	Display value
GEAR	During driving	1, 2, 3, 4, 5

### Diagnosis Procedure

INFOID:000000001327359

#### 1. CHECK INPUT SIGNALS

##### Ⓟ With CONSULT-III

1. Start engine.
2. Select "MAIN SIGNALS" in "DATA MONITOR" mode for "TRANSMISSION" with CONSULT-III and read out the value of "GEAR".
3. Drive vehicle in the manual mode, and confirm that the actual gear position and the meter's indication of the position mutually coincide when the selector lever is shifted to the "+ (up)" or "- (down)" side (1st ↔ 5th gear).

##### OK or NG

OK >> **INSPECTION END**

NG >> Check the following.

### A/T INDICATOR SYMPTOM CHART

Items	Presumed Location of Trouble
The actual gear position does not change, or shifting into the manual mode is not possible (no gear shifting in the manual mode possible). The A/T indicator is not indicated.	Manual mode switch <ul style="list-style-type: none"><li>• Refer to <a href="#">AT-155</a>.</li></ul> A/T main system (Fail-safe function actuated) <ul style="list-style-type: none"><li>• Refer to <a href="#">AT-84</a>, "<a href="#">CONSULT-III Function (TRANSMISSION)</a>".</li></ul>
The actual gear position changes, but the A/T indicator is not indicated.	Perform the self-diagnosis function. <ul style="list-style-type: none"><li>• Refer to <a href="#">AT-84</a>, "<a href="#">CONSULT-III Function (TRANSMISSION)</a>".</li></ul>
The actual gear position and the indication on the A/T indicator do not coincide.	Perform the self-diagnosis function. <ul style="list-style-type: none"><li>• Refer to <a href="#">AT-84</a>, "<a href="#">CONSULT-III Function (TRANSMISSION)</a>".</li></ul>
Only a specific position or positions is/are not indicated on the A/T indicator.	Check the unified meter and A/C amp. <ul style="list-style-type: none"><li>• Refer to <a href="#">DI-5</a>.</li></ul>



# TROUBLE DIAGNOSIS FOR SYMPTOMS

< SERVICE INFORMATION >

AT-NONDTC-02

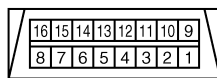
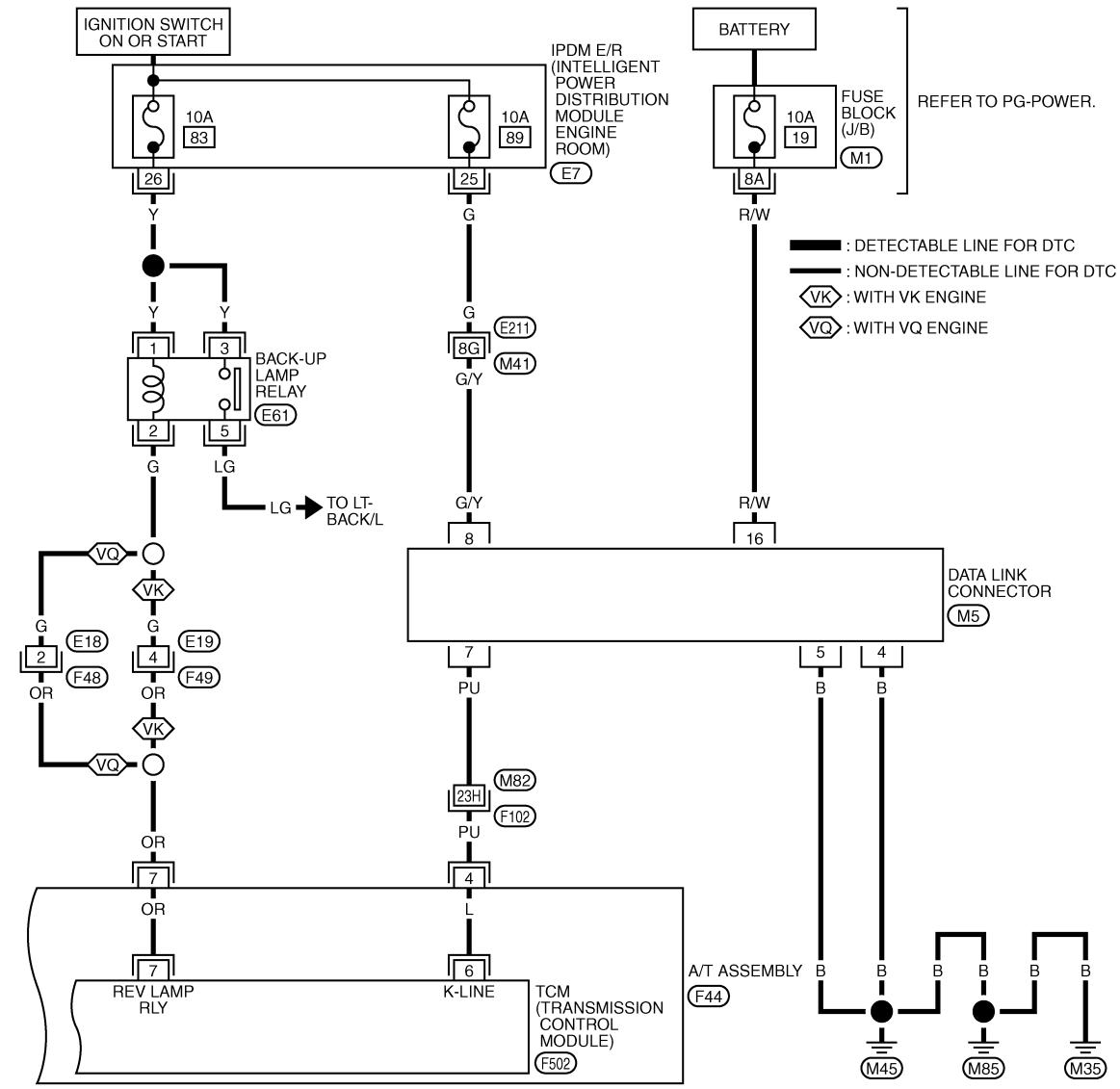

M5 W

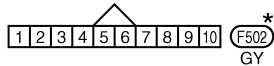
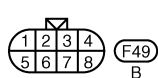
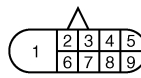
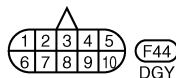
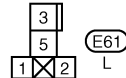

\*: THIS CONNECTOR IS NOT SHOWN IN "HARNESS LAYOUT", PG SECTION.

REFER TO THE FOLLOWING.  
 (E21), (F102) -SUPER MULTIPLE JUNCTION (SMJ)  
 (M1) -FUSE BLOCK-JUNCTION BOX (J/B)

TCWM0501E



# TROUBLE DIAGNOSIS FOR SYMPTOMS

< SERVICE INFORMATION >

AT-NONDTC-03

: DETECTABLE LINE FOR DTC  
 : NON-DETECTABLE LINE FOR DTC

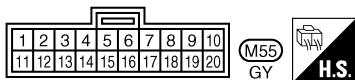
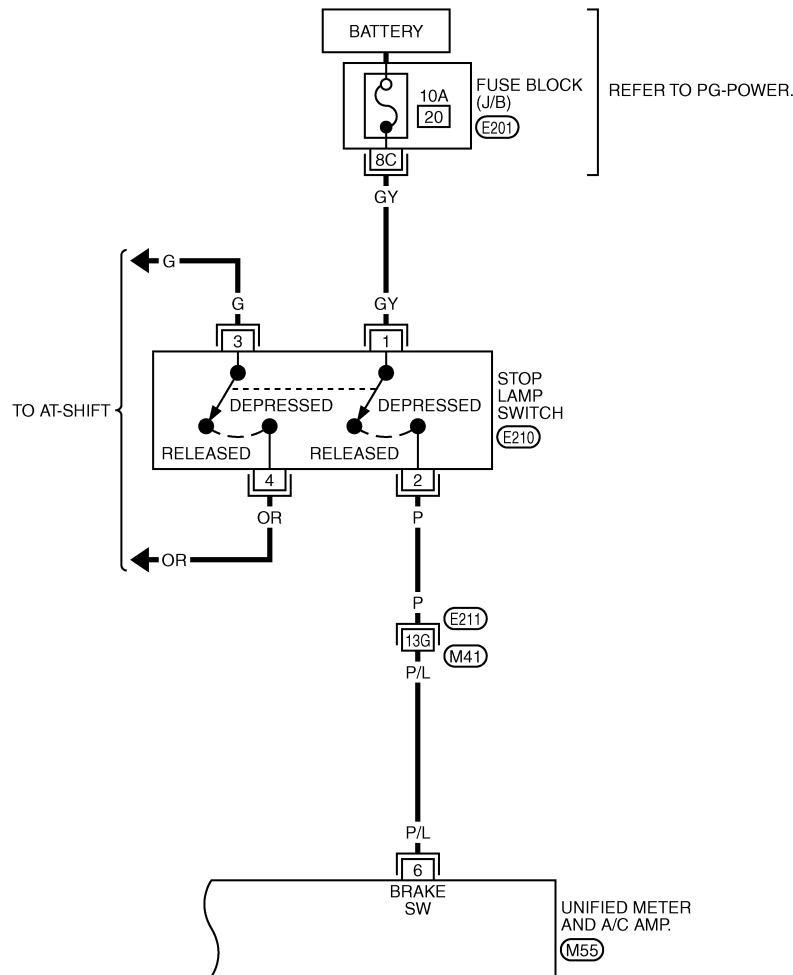

REFER TO THE FOLLOWING.  
 (E211) -SUPER MULTIPLE JUNCTION (SMJ)  
 (E201) -FUSE BLOCK-JUNCTION BOX (J/B)

TCM terminals and data are reference value. Measured between each terminal and ground.

TCWM0502E

Terminal	Wire color	Item	Condition	Data (Approx.)
3	L	CAN-H	-	-
4	PU	K-line (CONSULT-III signal)	The terminal is connected to the data link connector for CONSULT-III.	-

# TROUBLE DIAGNOSIS FOR SYMPTOMS

## < SERVICE INFORMATION >

Terminal	Wire color	Item	Condition	Data (Approx.)
7	OR	Back-up lamp relay	 Selector lever in "R" position.	0 V
			Selector lever in other positions.	Battery voltage
8	P	CAN-L	-	-

### A/T Check Indicator Lamp Does Not Come On

INFOID:000000001327361

#### SYMPTOM:

**A/T CHECK indicator lamp does not come on for about 2 seconds when turning ignition switch to "ON".**

#### DIAGNOSTIC PROCEDURE

### 1. CHECK CAN COMMUNICATION LINE

#### With CONSULT-III

- Perform self-diagnosis.

#### Without CONSULT-III

- Perform self-diagnosis. Refer to [AT-91. "Diagnosis Procedure without CONSULT-III"](#).

Is a malfunction in the CAN communication indicated in the results?

- YES >> Check CAN communication line. Refer to [AT-94](#).  
 NO >> GO TO 2.

### 2. CHECK A/T CHECK INDICATOR LAMP CIRCUIT

Check the combination meter. Refer to [DI-5](#).

OK or NG

- OK >> GO TO 3  
 NG >> Repair or replace damaged parts.

### 3. CHECK TCM POWER SUPPLY AND GROUND CIRCUIT

Check TCM power supply and ground circuit. Refer to [AT-160](#).

OK or NG

- OK >> **INSPECTION END**  
 NG >> Repair or replace damaged parts.

### Engine Cannot Be Started in "P" or "N" Position

INFOID:000000001327362

#### SYMPTOM:

- Engine cannot be started with selector lever in "P" or "N" position.
- Engine can be started with selector lever in "D" or "R" position.

#### DIAGNOSTIC PROCEDURE

### 1. CHECK PNP SWITCH CIRCUIT

#### With CONSULT-III

- Perform self-diagnosis.

#### Without CONSULT-III

- Perform self-diagnosis. Refer to [AT-91. "Diagnosis Procedure without CONSULT-III"](#).

Do the self-diagnosis results indicate PNP switch?

- YES >> Check the malfunctioning system. Refer to [AT-102](#).  
 NO >> GO TO 2.

### 2. CHECK A/T POSITION

# TROUBLE DIAGNOSIS FOR SYMPTOMS

## < SERVICE INFORMATION >

Check the A/T position. Refer to [AT-207, "Checking of A/T Position"](#).

### OK or NG

- OK >> GO TO 3.
- NG >> Adjust A/T position. Refer to [AT-207, "Adjustment of A/T Position"](#).

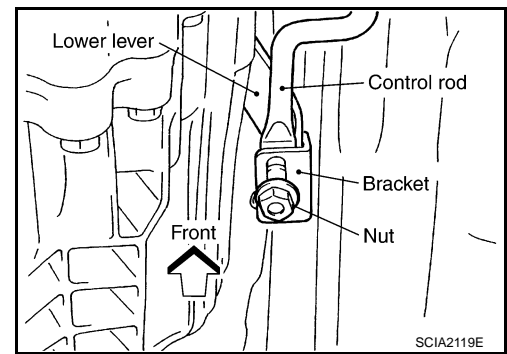

## 3.CHECK STARTING SYSTEM

Check starting system. Refer to [SC-8](#).

### OK or NG

- OK >> **INSPECTION END**
- NG >> Repair or replace damaged parts.

## In "P" Position, Vehicle Moves When Pushed

INFOID:000000001327363

### SYMPTOM:

Even though the selector lever is set in the "P" position, the parking mechanism is not actuated, allowing the vehicle to be moved when it is pushed.

### DIAGNOSTIC PROCEDURE

#### 1.CHECK A/T POSITION

Check the A/T position. Refer to [AT-207, "Checking of A/T Position"](#).

### OK or NG

- OK >> GO TO 2.
- NG >> Adjust A/T position. Refer to [AT-207, "Adjustment of A/T Position"](#).

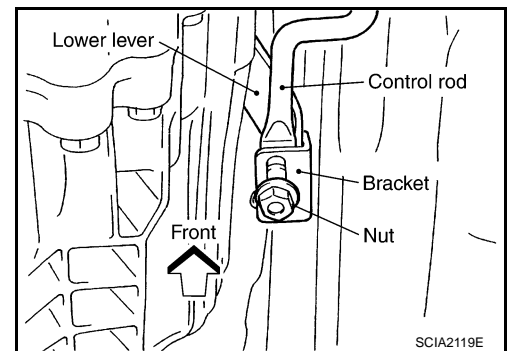

#### 2.CHECK PARKING COMPONENTS

Check parking components. Refer to [AT-226, "Parking Component \(2WD Models Only\)"](#) (2WD models) or [AT-267, "Disassembly"](#) (AWD models).

### OK or NG

- OK >> GO TO 3.
- NG >> Repair or replace damaged parts.

#### 3.CHECK A/T FLUID CONDITION

1. Remove oil pan. Refer to [AT-215, "Control Valve with TCM and A/T Fluid Temperature Sensor 2"](#).
2. Check A/T fluid condition. Refer to [AT-49, "Inspections Before Trouble Diagnosis"](#).

### OK or NG

- OK >> **INSPECTION END**
- NG >> Check the malfunction items. If any items are damaged, repair or replace damaged parts. Refer to [AT-59, "Symptom Chart"](#) (Symptom No.65).

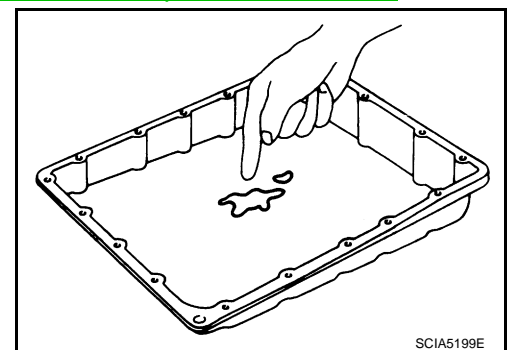

# TROUBLE DIAGNOSIS FOR SYMPTOMS

< SERVICE INFORMATION >

In "N" Position, Vehicle Moves

INFOID:000000001327364

SYMPTOM:

Vehicle moves forward or backward when selecting "N" position.

DIAGNOSTIC PROCEDURE

## 1. CHECK PNP SWITCH CIRCUIT

④ With CONSULT-III

- Perform self-diagnosis.

⊗ Without CONSULT-III

- Perform self-diagnosis. Refer to [AT-91, "Diagnosis Procedure without CONSULT-III"](#).

Do the self-diagnostic results indicate PNP switch?

YES >> Check the malfunctioning system. Refer to [AT-102](#).

NO >> GO TO 2.

## 2. CHECK A/T POSITION

Check the A/T position. Refer to [AT-207, "Checking of A/T Position"](#).

OK or NG

OK >> GO TO 3.

NG >> Adjust A/T position. Refer to [AT-207, "Adjustment of A/T Position"](#).

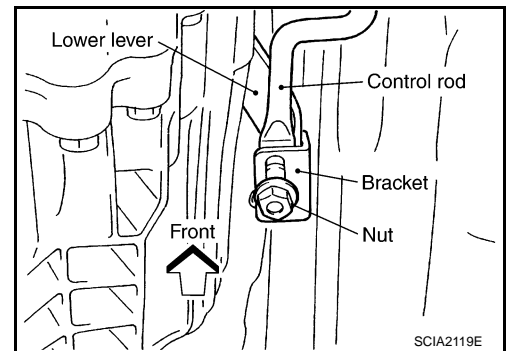

## 3. CHECK A/T FLUID LEVEL

Check A/T fluid level. Refer to [AT-11, "Checking A/T Fluid"](#).

OK or NG

OK >> GO TO 4.

NG >> Refill ATF.

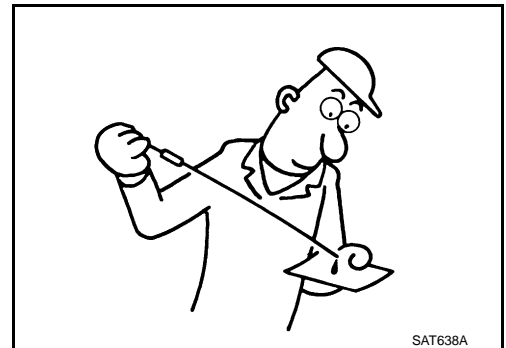

## 4. CHECK A/T FLUID CONDITION

1. Remove oil pan. Refer to [AT-215, "Control Valve with TCM and A/T Fluid Temperature Sensor 2"](#).

2. Check A/T fluid condition. Refer to [AT-49, "Inspections Before Trouble Diagnosis"](#).

OK or NG

OK >> GO TO 5.

NG >> Check the malfunction items. If any items are damaged, repair or replace damaged parts. Refer to [AT-59, "Symptom Chart"](#) (Symptom No.67).

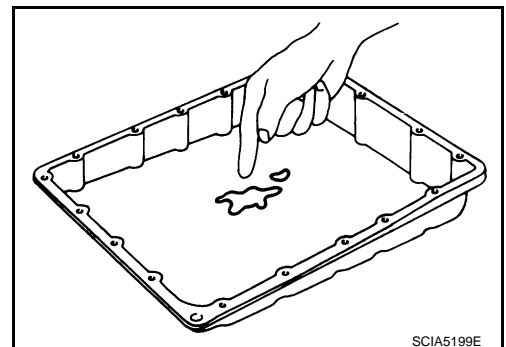

## 5. CHECK SYMPTOM

Check again. Refer to "CHECK AT IDLE".

# TROUBLE DIAGNOSIS FOR SYMPTOMS

## < SERVICE INFORMATION >

### OK or NG

- OK >> **INSPECTION END**
- NG >> GO TO 6.

## 6.CHECK TCM

1. Check TCM input/output signals. Refer to [AT-83, "TCM Input/Output Signal Reference Value"](#).
2. If NG, recheck A/T assembly harness connector terminals for damage or loose connection with harness connector.

### OK or NG

- OK >> **INSPECTION END**
- NG >> Repair or replace damaged parts.

## Large Shock ("N" to "D" Position)

INFOID:000000001327365

### SYMPTOM:

**A noticeable shock occurs when the selector lever is shifted from "N" to "D" position.**

### DIAGNOSTIC PROCEDURE

## 1.CHECK SELF-DIAGNOSTIC RESULTS

### With CONSULT-III

- Perform self-diagnosis.

### Without CONSULT-III

- Perform self-diagnosis. Refer to [AT-91, "Diagnosis Procedure without CONSULT-III"](#).

### Is any malfunction detected by self-diagnostic results?

- YES >> Check the malfunctioning system. Refer to [AT-84, "CONSULT-III Function \(TRANSMISSION\)"](#), [AT-91, "Diagnosis Procedure without CONSULT-III"](#).
- NO >> GO TO 2.

## 2.ENGINE IDLE SPEED

Check the engine idle speed. Refer to [EC-84, "Idle Speed and Ignition Timing Check"](#) (for VQ35DE) or [EC-661, "Idle Speed and Ignition Timing Check"](#) (for VK45DE).

### OK or NG

- OK >> GO TO 3.
- NG >> Adjust engine idle speed. Refer to [EC-84, "Idle Speed and Ignition Timing Check"](#) (for VQ35DE) or [EC-661, "Idle Speed and Ignition Timing Check"](#) (for VK45DE).

## 3.CHECK A/T POSITION

Check the A/T position. Refer to [AT-207, "Checking of A/T Position"](#).

### OK or NG

- OK >> GO TO 4.
- NG >> Adjust A/T position. Refer to [AT-207, "Adjustment of A/T Position"](#).

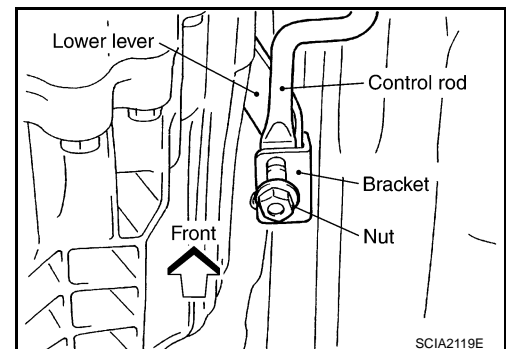

## 4.CHECK A/T FLUID LEVEL

## TROUBLE DIAGNOSIS FOR SYMPTOMS

### < SERVICE INFORMATION >

Check the A/T fluid level. Refer to [AT-11, "Checking A/T Fluid"](#).

#### OK or NG

- OK >> GO TO 5.
- NG >> Refill ATF.

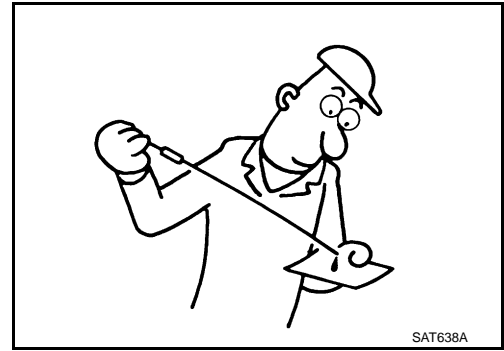

### 5. CHECK LINE PRESSURE

Check line pressure at idle with selector lever in "D" position. Refer to [AT-49, "Inspections Before Trouble Diagnosis"](#).

#### OK or NG

- OK >> GO TO 8.
- NG-1 >> Line pressure high: GO TO 6.
- NG-2 >> Line pressure low: GO TO 7.

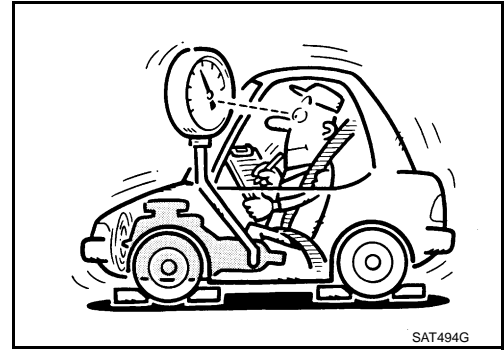

### 6. DETECT MALFUNCTIONING ITEM

1. Check control valve with TCM. Refer to [AT-215, "Control Valve with TCM and A/T Fluid Temperature Sensor 2"](#).
2. Disassemble A/T. Refer to [AT-267](#).
3. Check the following.
  - Oil pump assembly. Refer to [AT-285, "Oil Pump"](#).

#### OK or NG

- OK >> GO TO 8.
- NG >> Repair or replace damaged parts.

### 7. DETECT MALFUNCTIONING ITEM

1. Check control valve with TCM. Refer to [AT-215, "Control Valve with TCM and A/T Fluid Temperature Sensor 2"](#).
2. Disassemble A/T. Refer to [AT-267](#).
3. Check the following.
  - Oil pump assembly. Refer to [AT-285, "Oil Pump"](#).
  - Power train system. Refer to [AT-267](#).
  - Transmission case. Refer to [AT-267](#).

#### OK or NG

- OK >> GO TO 8.
- NG >> Repair or replace damaged parts.

### 8. CHECK A/T FLUID CONDITION

1. Remove oil pan. Refer to [AT-215, "Control Valve with TCM and A/T Fluid Temperature Sensor 2"](#).

# TROUBLE DIAGNOSIS FOR SYMPTOMS

## < SERVICE INFORMATION >

2. Check A/T fluid condition. Refer to [AT-49, "Inspections Before Trouble Diagnosis"](#).

### OK or NG

- OK >> GO TO 10.
- NG >> GO TO 9.

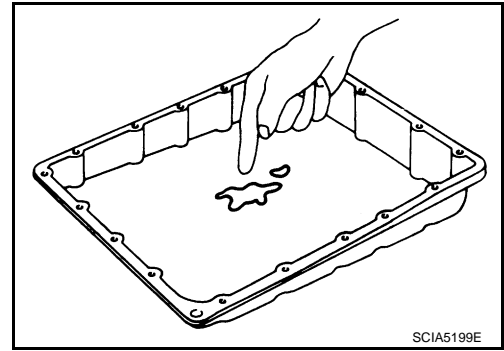

## 9. DETECT MALFUNCTIONING ITEM

Check the malfunction items. If any items are damaged, repair or replace damaged parts. Refer to [AT-59, "Symptom Chart"](#) (Symptom No.1).

### OK or NG

- OK >> GO TO 10.
- NG >> Repair or replace damaged parts.

## 10. CHECK SYMPTOM

Check again. Refer to "CHECK AT IDLE".

### OK or NG

- OK >> **INSPECTION END**
- NG >> GO TO 11.

## 11. CHECK TCM

1. Check TCM input/output signals. Refer to [AT-83, "TCM Input/Output Signal Reference Value"](#).
2. If NG, recheck A/T assembly harness connector terminals for damage or loose connection with harness connector.

### OK or NG

- OK >> **INSPECTION END**
- NG >> Repair or replace damaged parts.

## Vehicle Does Not Creep Backward in "R" Position

INFOID:000000001327366

### SYMPTOM:

**The vehicle does not creep in the "R" position. Or an extreme lack of acceleration is observed.**

### DIAGNOSTIC PROCEDURE

## 1. CHECK SELF-DIAGNOSTIC RESULTS

### With CONSULT-III

- Perform self-diagnosis.

### Without CONSULT-III

- Perform self-diagnosis. Refer to [AT-91, "Diagnosis Procedure without CONSULT-III"](#).

Is any malfunction detected by self-diagnostic results?

- YES >> Check the malfunctioning system. Refer to [AT-84, "CONSULT-III Function \(TRANSMISSION\)"](#), [AT-91, "Diagnosis Procedure without CONSULT-III"](#).
- NO >> GO TO 2.

## 2. CHECK A/T POSITION

# TROUBLE DIAGNOSIS FOR SYMPTOMS

## < SERVICE INFORMATION >

Check the A/T position. Refer to [AT-207. "Checking of A/T Position"](#).

### OK or NG

OK >> GO TO 3.

NG >> Adjust A/T position. Refer to [AT-207. "Adjustment of A/T Position"](#).

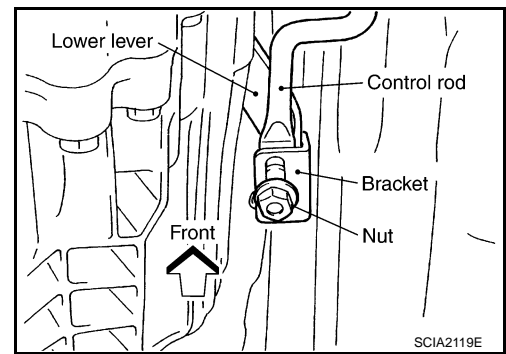

## 3. CHECK A/T FLUID LEVEL

Check A/T fluid level. Refer to [AT-11. "Checking A/T Fluid"](#).

### OK or NG

OK >> GO TO 4.

NG >> Refill ATF.

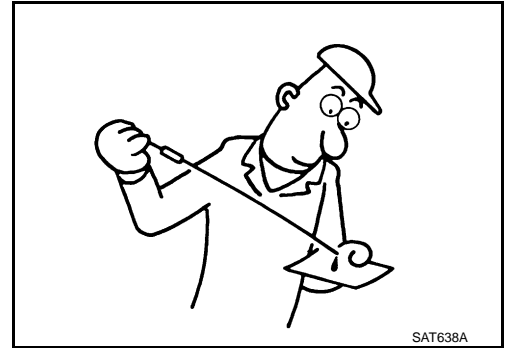

## 4. CHECK STALL TEST

Check stall revolution with selector lever in "M" and "R" positions. Refer to [AT-49. "Inspections Before Trouble Diagnosis"](#).

### OK or NG

OK >> GO TO 6.

OK in "M" position, NG in "R" position >> GO TO 5

NG in both "M" and "R" positions >> GO TO 8.

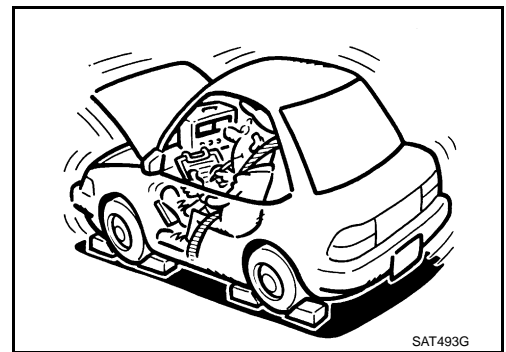

## 5. DETECT MALFUNCTIONING ITEM

1. Disassemble A/T. Refer to [AT-267](#).

2. Check the following.

- Reverse brake. Refer to [AT-267](#).

### OK or NG

OK >> GO TO 9.

NG >> Repair or replace damaged parts.

## 6. CHECK LINE PRESSURE

Check the line pressure with the engine idling. Refer to [AT-49. "Inspections Before Trouble Diagnosis"](#).

### OK or NG

OK >> GO TO 9.

NG-1 >> Line pressure high: GO TO 7.

NG-2 >> Line pressure low: GO TO 8.

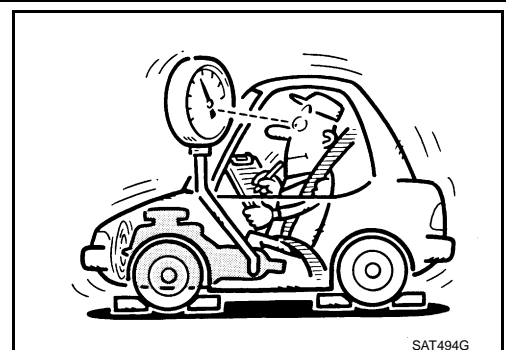



# TROUBLE DIAGNOSIS FOR SYMPTOMS

## < SERVICE INFORMATION >

### 7. DETECT MALFUNCTIONING ITEM

1. Check control valve with TCM. Refer to [AT-215, "Control Valve with TCM and A/T Fluid Temperature Sensor 2"](#).
2. Disassemble A/T. Refer to [AT-267](#).
3. Check the following.
  - Oil pump assembly. Refer to [AT-285, "Oil Pump"](#).

#### OK or NG

- OK >> GO TO 9.  
NG >> Repair or replace damaged parts.

### 8. DETECT MALFUNCTIONING ITEM

1. Check control valve with TCM. Refer to [AT-215, "Control Valve with TCM and A/T Fluid Temperature Sensor 2"](#).
2. Disassemble A/T. Refer to [AT-267](#).
3. Check the following.
  - Oil pump assembly. Refer to [AT-285, "Oil Pump"](#).
  - Power train system. Refer to [AT-267](#).
  - Transmission case. Refer to [AT-267](#).

#### OK or NG

- OK >> GO TO 9.  
NG >> Repair or replace damaged parts.

### 9. CHECK A/T FLUID CONDITION

1. Remove oil pan. Refer to [AT-215, "Control Valve with TCM and A/T Fluid Temperature Sensor 2"](#).
2. Check A/T fluid condition. Refer to [AT-49, "Inspections Before Trouble Diagnosis"](#).

#### OK or NG

- OK >> GO TO 10.  
NG >> GO TO 13.

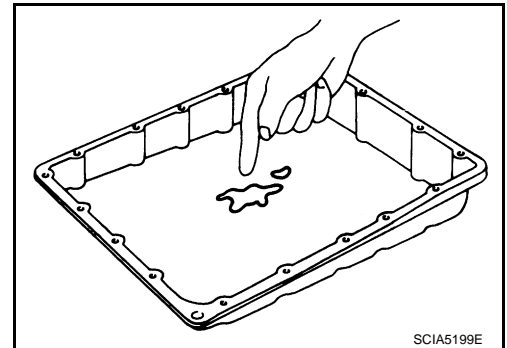

### 10. DETECT MALFUNCTIONING ITEM

Check the malfunction items. If any items are damaged, repair or replace damaged parts. Refer to [AT-59, "Symptom Chart"](#) (Symptom No.43).

#### OK or NG

- OK >> GO TO 11.  
NG >> Repair or replace damaged parts.

### 11. CHECK SYMPTOM

Check again. Refer to "CHECK AT IDLE".

#### OK or NG

- OK >> **INSPECTION END**  
NG >> GO TO 12.

### 12. CHECK TCM

1. Check TCM input/output signals. Refer to [AT-83, "TCM Input/Output Signal Reference Value"](#).
2. If NG, recheck A/T assembly harness connector terminals for damage or loose connection with harness connector.

#### OK or NG

- OK >> **INSPECTION END**  
NG >> Repair or replace damaged parts.

# TROUBLE DIAGNOSIS FOR SYMPTOMS

< SERVICE INFORMATION >

## 13. DETECT MALFUNCTIONING ITEM

Check the malfunction items. If any items are damaged, repair or replace damaged parts. Refer to [AT-59, "Symptom Chart"](#) (Symptom No.43).

OK or NG

- OK >> GO TO 11.
- NG >> Repair or replace damaged parts.

### Vehicle Does Not Creep Forward in "D" Position

INFOID:000000001327367

SYMPTOM:

Vehicle does not creep forward when selecting "D" position.

DIAGNOSTIC PROCEDURE

#### 1. CHECK SELF-DIAGNOSTIC RESULTS

With CONSULT-III

- Perform self-diagnosis.

Without CONSULT-III

- Perform self-diagnosis. Refer to [AT-91, "Diagnosis Procedure without CONSULT-III"](#).

Is any malfunction detected by self-diagnostic results?

- YES >> Check the malfunctioning system. Refer to [AT-84, "CONSULT-III Function \(TRANSMISSION\)"](#), [AT-91, "Diagnosis Procedure without CONSULT-III"](#).
- NO >> GO TO 2.

#### 2. CHECK A/T POSITION

Check the A/T position. Refer to [AT-207, "Checking of A/T Position"](#).

OK or NG

- OK >> GO TO 3.
- NG >> Adjust A/T position. Refer to [AT-207, "Adjustment of A/T Position"](#).

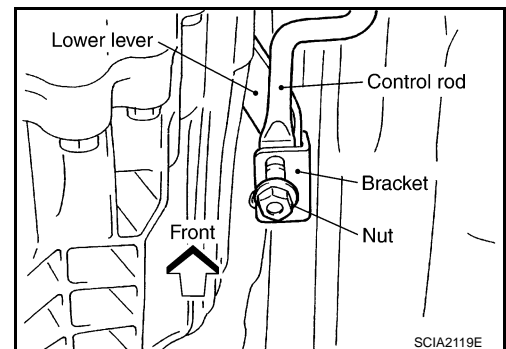

#### 3. CHECK A/T FLUID LEVEL

Check A/T fluid level. Refer to [AT-11, "Checking A/T Fluid"](#).

OK or NG

- OK >> GO TO 4.
- NG >> Refill ATF.

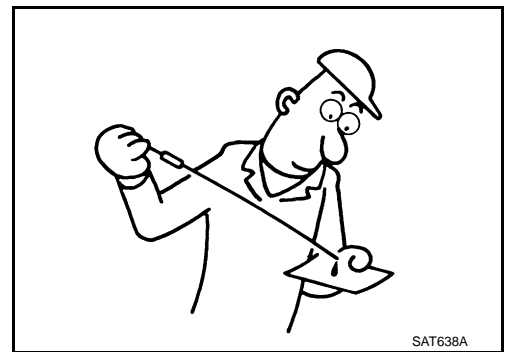

#### 4. CHECK STALL TEST

# TROUBLE DIAGNOSIS FOR SYMPTOMS

## < SERVICE INFORMATION >

Check stall revolution with selector lever in "D" position. Refer to [AT-49, "Inspections Before Trouble Diagnosis"](#).

### OK or NG

- OK >> GO TO 5.
- NG >> GO TO 7.

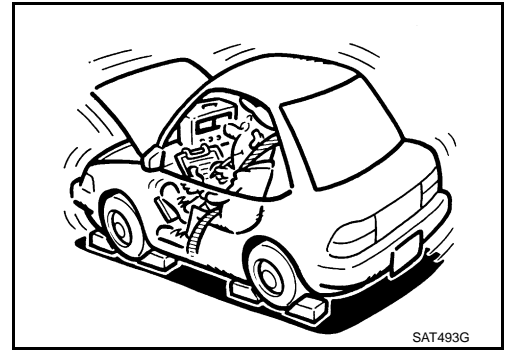

## 5. CHECK LINE PRESSURE

Check line pressure at idle with selector lever in "D" position. Refer to [AT-49, "Inspections Before Trouble Diagnosis"](#).

### OK or NG

- OK >> GO TO 8.
- NG-1 >> Line pressure high: GO TO 6.
- NG-2 >> Line pressure low: GO TO 7.

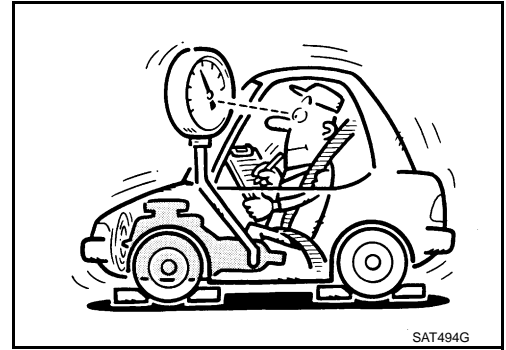

## 6. DETECT MALFUNCTIONING ITEM

1. Check control valve with TCM. Refer to [AT-215, "Control Valve with TCM and A/T Fluid Temperature Sensor 2"](#).
2. Disassemble A/T. Refer to [AT-267](#).
3. Check the following.
  - Oil pump assembly. Refer to [AT-285, "Oil Pump"](#).

### OK or NG

- OK >> GO TO 8.
- NG >> Repair or replace damaged parts.

## 7. DETECT MALFUNCTIONING ITEM

1. Check control valve with TCM. Refer to [AT-215, "Control Valve with TCM and A/T Fluid Temperature Sensor 2"](#).
2. Disassemble A/T. Refer to [AT-267](#).
3. Check the following.
  - Oil pump assembly. Refer to [AT-285, "Oil Pump"](#).
  - Power train system. Refer to [AT-267](#).
  - Transmission case. Refer to [AT-267](#).

### OK or NG

- OK >> GO TO 8.
- NG >> Repair or replace damaged parts.

## 8. CHECK A/T FLUID CONDITION

1. Remove oil pan. Refer to [AT-215, "Control Valve with TCM and A/T Fluid Temperature Sensor 2"](#).

A  
B  
AT  
D  
E  
F  
G  
H  
I  
J  
K  
L  
M  
N  
O  
P

## TROUBLE DIAGNOSIS FOR SYMPTOMS

< SERVICE INFORMATION >

2. Check A/T fluid condition. Refer to [AT-49. "Inspections Before Trouble Diagnosis"](#).

OK or NG

- OK >> GO TO 9.  
NG >> GO TO 12.

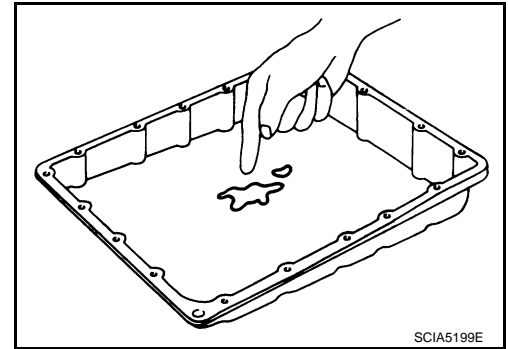

### 9. DETECT MALFUNCTIONING ITEM

Check the malfunction items. If any items are damaged, repair or replace damaged parts. Refer to [AT-59. "Symptom Chart"](#) (Symptom No.43).

OK or NG

- OK >> GO TO 10.  
NG >> Repair or replace damaged parts.

### 10. CHECK SYMPTOM

Check again. Refer to "CHECK AT IDLE".

OK or NG

- OK >> **INSPECTION END**  
NG >> GO TO 11.

### 11. CHECK TCM

1. Check TCM input/output signals. Refer to [AT-83. "TCM Input/Output Signal Reference Value"](#).
2. If NG, recheck A/T assembly harness connector terminals for damage or loose connection with harness connector.

OK or NG

- OK >> **INSPECTION END**  
NG >> Repair or replace damaged parts.

### 12. DETECT MALFUNCTIONING ITEM

Check the malfunction items. If any items are damaged, repair or replace damaged parts. Refer to [AT-59. "Symptom Chart"](#) (Symptom No.43).

OK or NG

- OK >> GO TO 10.  
NG >> Repair or replace damaged parts.

## Vehicle Cannot Be Started from D1

INFOID:000000001327368

SYMPTOM:

Vehicle cannot be started from D1 on "Cruise Test - Part 1" and "Cruise Test - Part2".

DIAGNOSTIC PROCEDURE

### 1. CONFIRM THE SYMPTOM

Check if vehicle creeps in "R" position.

OK or NG

- OK >> GO TO 2.  
NG >> Refer to [AT-175. "Vehicle Does Not Creep Backward in "R" Position"](#).

### 2. CHECK SELF-DIAGNOSTIC RESULTS

**With CONSULT-III**

- Perform self-diagnosis.

**Without CONSULT-III**

# TROUBLE DIAGNOSIS FOR SYMPTOMS

## < SERVICE INFORMATION >

- Perform self-diagnosis. Refer to [AT-91, "Diagnosis Procedure without CONSULT-III"](#)

Is any malfunction detected by self-diagnostic results?

YES >> Check the malfunctioning system. Refer to [AT-84, "CONSULT-III Function \(TRANSMISSION\)"](#), [AT-91, "Diagnosis Procedure without CONSULT-III"](#).

NO >> GO TO 3.

### 3.CHECK ACCELERATOR POSITION SENSOR

Check accelerator pedal position sensor. Refer to [AT-130](#)

OK or NG

OK >> GO TO 4.

NG >> Repair or replace accelerator pedal position sensor.

### 4.CHECK A/T FLUID LEVEL

Check A/T fluid level. Refer to [AT-11, "Checking A/T Fluid"](#).

OK or NG

OK >> GO TO 5.

NG >> Refill ATF.

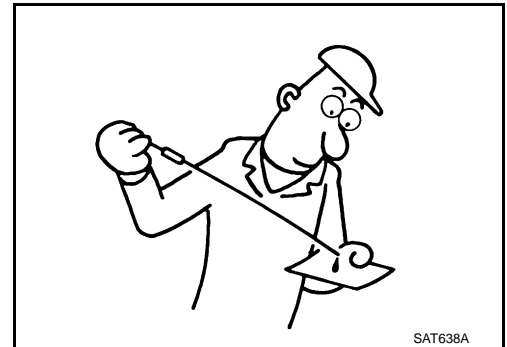

### 5.CHECK LINE PRESSURE

Check line pressure at the engine stall point. Refer to [AT-49, "Inspections Before Trouble Diagnosis"](#).

OK or NG

OK >> GO TO 8.

NG-1 >> Line pressure high: GO TO 6.

NG-2 >> Line pressure low: GO TO 7.

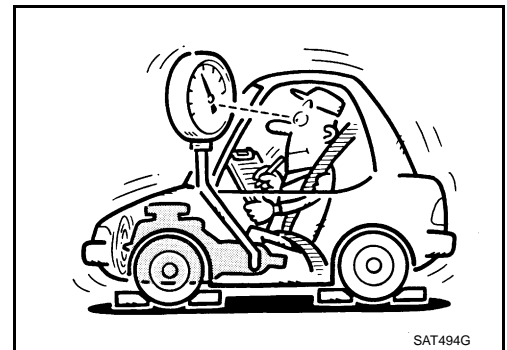

### 6.DETECT MALFUNCTIONING ITEM

1. Check control valve with TCM. Refer to [AT-215, "Control Valve with TCM and A/T Fluid Temperature Sensor 2"](#).
2. Disassemble A/T. Refer to [AT-267](#).
3. Check the following.
  - Oil pump assembly. Refer to [AT-285, "Oil Pump"](#).

OK or NG

OK >> GO TO 8.

NG >> Repair or replace damaged parts.

### 7.DETECT MALFUNCTIONING ITEM

1. Check control valve with TCM. Refer to [AT-215, "Control Valve with TCM and A/T Fluid Temperature Sensor 2"](#).
2. Disassemble A/T. Refer to [AT-267](#).
3. Check the following.
  - Oil pump assembly. Refer to [AT-285, "Oil Pump"](#).
  - Power train system. Refer to [AT-267](#).
  - Transmission case. Refer to [AT-267](#).

OK or NG

OK >> GO TO 8.

# TROUBLE DIAGNOSIS FOR SYMPTOMS

## < SERVICE INFORMATION >

NG >> Repair or replace damaged parts.

### 8. CHECK A/T FLUID CONDITION

1. Remove oil pan. Refer to [AT-215, "Control Valve with TCM and A/T Fluid Temperature Sensor 2"](#).
2. Check A/T fluid condition. Refer to [AT-49, "Inspections Before Trouble Diagnosis"](#).

#### OK or NG

OK >> GO TO 9.  
NG >> GO TO 12.

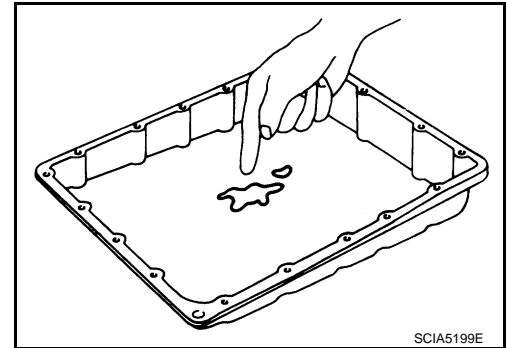

### 9. DETECT MALFUNCTIONING ITEM

Check the malfunction items. If any items are damaged, repair or replace damaged parts. Refer to [AT-59, "Symptom Chart"](#) (Symptom No.23).

#### OK or NG

OK >> GO TO 10.  
NG >> Repair or replace damaged parts.

### 10. CHECK SYMPTOM

Check again. Refer to [AT-53, "Road Test"](#).

#### OK or NG

OK >> **INSPECTION END**  
NG >> GO TO 11.

### 11. CHECK TCM

1. Check TCM input/output signals. Refer to [AT-83, "TCM Input/Output Signal Reference Value"](#).
2. If NG, recheck A/T assembly harness connector terminals for damage or loose connection with harness connector.

#### OK or NG

OK >> **INSPECTION END**  
NG >> Repair or replace damaged parts.

### 12. DETECT MALFUNCTIONING ITEM

Check the malfunction items. If any items are damaged, repair or replace damaged parts. Refer to [AT-59, "Symptom Chart"](#) (Symptom No.23).

#### OK or NG

OK >> GO TO 10.  
NG >> Repair or replace damaged parts.

## A/T Does Not Shift: D1 → D2

INFOID:000000001327369

#### SYMPTOM:

**The vehicle does not shift-up from the D1 to D2 gear at the specified speed.**

#### DIAGNOSTIC PROCEDURE

### 1. CONFIRM THE SYMPTOM

Check if vehicle creeps forward in "D" position and vehicle can be started from D1.

#### OK or NG

OK >> GO TO 2.  
NG >> Refer to [AT-178, "Vehicle Does Not Creep Forward in "D" Position"](#), [AT-180, "Vehicle Cannot Be Started from D1"](#).

### 2. CHECK SELF-DIAGNOSTIC RESULTS

# TROUBLE DIAGNOSIS FOR SYMPTOMS

## < SERVICE INFORMATION >

### With CONSULT-III

- Perform self-diagnosis.

### Without CONSULT-III

- Perform self-diagnosis. Refer to [AT-91, "Diagnosis Procedure without CONSULT-III"](#).

Is any malfunction detected by self-diagnostic results?

YES >> Check the malfunctioning system. Refer to [AT-84, "CONSULT-III Function \(TRANSMISSION\)"](#), [AT-91, "Diagnosis Procedure without CONSULT-III"](#).

NO >> GO TO 3.

## 3.CHECK A/T FLUID LEVEL

Check A/T fluid level. Refer to [AT-11, "Checking A/T Fluid"](#).

OK or NG

OK >> GO TO 4.

NG >> Refill ATF.

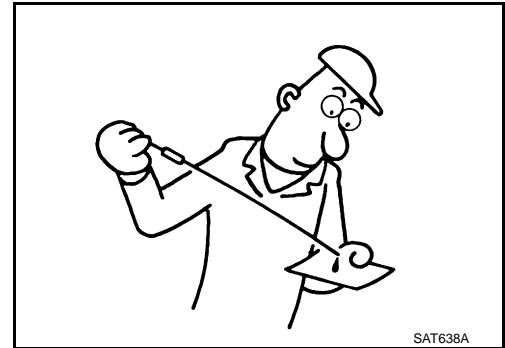

## 4.CHECK LINE PRESSURE

Check line pressure at the engine stall point. Refer to [AT-49, "Inspections Before Trouble Diagnosis"](#).

OK or NG

OK >> GO TO 7.

NG-1 >> Line pressure high: GO TO 5.

NG-2 >> Line pressure low: GO TO 6.

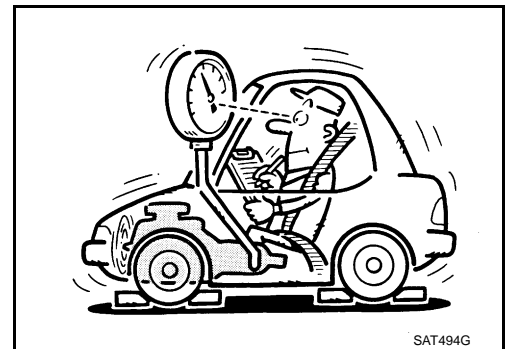

## 5.DETECT MALFUNCTIONING ITEM

1. Check control valve with TCM. Refer to [AT-215, "Control Valve with TCM and A/T Fluid Temperature Sensor 2"](#).
2. Disassemble A/T. Refer to [AT-267](#).
3. Check the following.
  - Oil pump assembly. Refer to [AT-285, "Oil Pump"](#).

OK or NG

OK >> GO TO 7.

NG >> Repair or replace damaged parts.

## 6.DETECT MALFUNCTIONING ITEM

1. Check control valve with TCM. Refer to [AT-215, "Control Valve with TCM and A/T Fluid Temperature Sensor 2"](#).
2. Disassemble A/T. Refer to [AT-267](#).
3. Check the following.
  - Oil pump assembly. Refer to [AT-285, "Oil Pump"](#).
  - Power train system. Refer to [AT-267](#).
  - Transmission case. Refer to [AT-267](#).

OK or NG

OK >> GO TO 7.

NG >> Repair or replace damaged parts.

## TROUBLE DIAGNOSIS FOR SYMPTOMS

< SERVICE INFORMATION >

### 7. CHECK A/T FLUID CONDITION

1. Remove oil pan. Refer to [AT-215, "Control Valve with TCM and A/T Fluid Temperature Sensor 2"](#).
2. Check A/T fluid condition. Refer to [AT-49, "Inspections Before Trouble Diagnosis"](#).

OK or NG

- OK >> GO TO 8.  
NG >> GO TO 11.

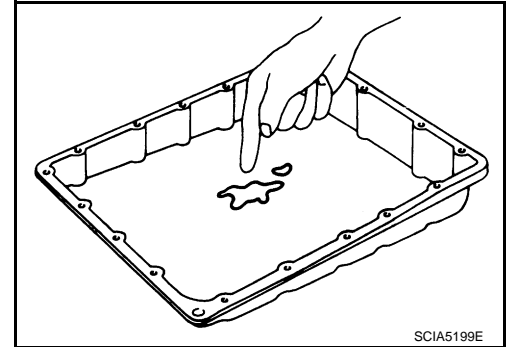

### 8. DETECT MALFUNCTIONING ITEM

Check the malfunction items. If any items are damaged, repair or replace damaged parts. Refer to [AT-59, "Symptom Chart"](#) (Symptom No.10).

OK or NG

- OK >> GO TO 9.  
NG >> Repair or replace damaged parts.

### 9. CHECK SYMPTOM

Check again. Refer to [AT-53, "Road Test"](#).

OK or NG

- OK >> **INSPECTION END**  
NG >> GO TO 10.

### 10. CHECK TCM

1. Check TCM input/output signals. Refer to [AT-83, "TCM Input/Output Signal Reference Value"](#).
2. If NG, recheck A/T assembly harness connector terminals for damage or loose connection with harness connector.

OK or NG

- OK >> **INSPECTION END**  
NG >> Repair or replace damaged parts.

### 11. DETECT MALFUNCTIONING ITEM

Check the malfunction items. If any items are damaged, repair or replace damaged parts. Refer to [AT-59, "Symptom Chart"](#) (Symptom No.10).

OK or NG

- OK >> GO TO 9.  
NG >> Repair or replace damaged parts.

**A/T Does Not Shift: D2→D3**

INFOID:000000001327370

**SYMPTOM:**

**The vehicle does not shift-up from D2 to D3 gear at the specified speed.**

**DIAGNOSTIC PROCEDURE**

#### 1. CONFIRM THE SYMPTOM

Check if vehicle creeps forward in "D" position and vehicle can be started from D1.

OK or NG

- OK >> GO TO 2.  
NG >> Refer to [AT-178, "Vehicle Does Not Creep Forward in "D" Position"](#), [AT-180, "Vehicle Cannot Be Started from D1"](#).

#### 2. CHECK SELF-DIAGNOSTIC RESULTS



# TROUBLE DIAGNOSIS FOR SYMPTOMS

## < SERVICE INFORMATION >

### With CONSULT-III

- Perform self-diagnosis.

### Without CONSULT-III

- Perform self-diagnosis. Refer to [AT-91, "Diagnosis Procedure without CONSULT-III"](#).

Is any malfunction detected by self-diagnostic results?

YES >> Check the malfunctioning system. Refer to [AT-84, "CONSULT-III Function \(TRANSMISSION\)"](#), [AT-91, "Diagnosis Procedure without CONSULT-III"](#).

NO >> GO TO 3.

## 3.CHECK A/T FLUID LEVEL

Check A/T fluid level. Refer to [AT-11, "Checking A/T Fluid"](#).

OK or NG

OK >> GO TO 4.

NG >> Refill ATF.

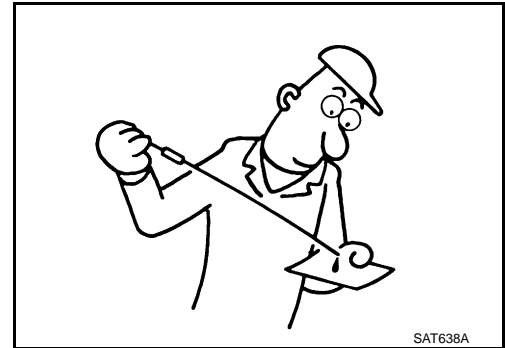

## 4.CHECK LINE PRESSURE

Check line pressure at the engine stall point. Refer to [AT-49, "Inspections Before Trouble Diagnosis"](#).

OK or NG

OK >> GO TO 7.

NG-1 >> Line pressure high: GO TO 5.

NG-2 >> Line pressure low: GO TO 6.

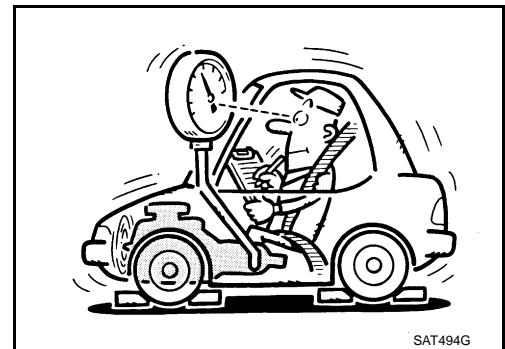

## 5.DETECT MALFUNCTIONING ITEM

1. Check control valve with TCM. Refer to [AT-215, "Control Valve with TCM and A/T Fluid Temperature Sensor 2"](#).
2. Disassemble A/T. Refer to [AT-267](#).
3. Check the following.
  - Oil pump assembly. Refer to [AT-285, "Oil Pump"](#).

OK or NG

OK >> GO TO 7.

NG >> Repair or replace damaged parts.

## 6.DETECT MALFUNCTIONING ITEM

1. Check control valve with TCM. Refer to [AT-215, "Control Valve with TCM and A/T Fluid Temperature Sensor 2"](#).
2. Disassemble A/T. Refer to [AT-267](#).
3. Check the following.
  - Oil pump assembly. Refer to [AT-285, "Oil Pump"](#).
  - Power train system. Refer to [AT-267](#).
  - Transmission case. Refer to [AT-267](#).

OK or NG

OK >> GO TO 7.

NG >> Repair or replace damaged parts.

## TROUBLE DIAGNOSIS FOR SYMPTOMS

< SERVICE INFORMATION >

### 7. CHECK A/T FLUID CONDITION

1. Remove oil pan. Refer to [AT-215, "Control Valve with TCM and A/T Fluid Temperature Sensor 2"](#).
2. Check A/T fluid condition. Refer to [AT-49, "Inspections Before Trouble Diagnosis"](#).

OK or NG

- OK >> GO TO 8.  
NG >> GO TO 11.

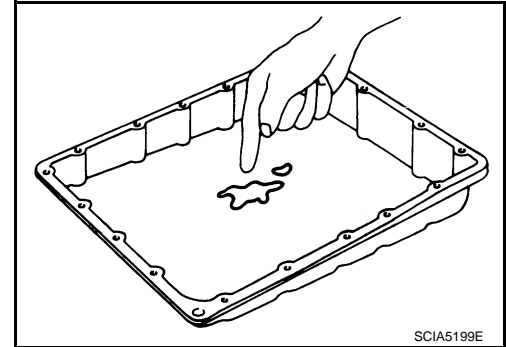

### 8. DETECT MALFUNCTIONING ITEM

Check the malfunction items. If any items are damaged, repair or replace damaged parts. Refer to [AT-59, "Symptom Chart"](#) (Symptom No.11).

OK or NG

- OK >> GO TO 9.  
NG >> Repair or replace damaged parts.

### 9. CHECK SYMPTOM

Check again. Refer to [AT-53, "Road Test"](#).

OK or NG

- OK >> **INSPECTION END**  
NG >> GO TO 10.

### 10. CHECK TCM

1. Check TCM input/output signals. Refer to [AT-83, "TCM Input/Output Signal Reference Value"](#).
2. If NG, recheck A/T assembly harness connector terminals for damage or loose connection with harness connector.

OK or NG

- OK >> **INSPECTION END**  
NG >> Repair or replace damaged parts.

### 11. DETECT MALFUNCTIONING ITEM

Check the malfunction items. If any items are damaged, repair or replace damaged parts. Refer to [AT-59, "Symptom Chart"](#) (Symptom No.11).

OK or NG

- OK >> GO TO 9.  
NG >> Repair or replace damaged parts.

**A/T Does Not Shift: D3→ D4**

INFOID:000000001327371

**SYMPTOM:**

**The vehicle does not shift-up from the D3 to D4 gear at the specified speed.**

**DIAGNOSTIC PROCEDURE**

#### 1. CONFIRM THE SYMPTOM

Check if vehicle creeps forward in "D" position and vehicle can be started from D1.

OK or NG

- OK >> GO TO 2.  
NG >> Refer to [AT-178, "Vehicle Does Not Creep Forward in "D" Position"](#), [AT-180, "Vehicle Cannot Be Started from D1"](#).

#### 2. CHECK SELF-DIAGNOSTIC RESULTS

# TROUBLE DIAGNOSIS FOR SYMPTOMS

## < SERVICE INFORMATION >

### With CONSULT-III

- Perform self-diagnosis.

### Without CONSULT-III

- Perform self-diagnosis. Refer to [AT-91, "Diagnosis Procedure without CONSULT-III"](#).

Is any malfunction detected by self-diagnostic results?

YES >> Check the malfunctioning system. Refer to [AT-84, "CONSULT-III Function \(TRANSMISSION\)"](#), [AT-91, "Diagnosis Procedure without CONSULT-III"](#).

NO >> GO TO 3.

## 3.CHECK A/T FLUID LEVEL

Check A/T fluid level. Refer to [AT-11, "Checking A/T Fluid"](#).

OK or NG

OK >> GO TO 4.

NG >> Refill ATF.

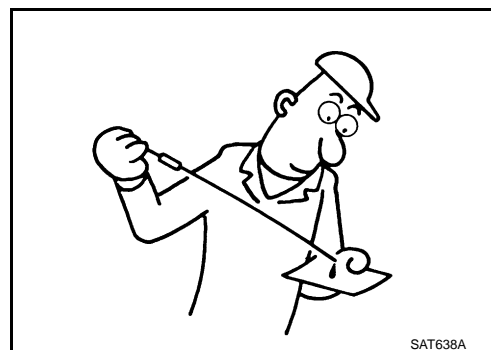

## 4.CHECK LINE PRESSURE

Check line pressure at the engine stall point. Refer to [AT-49, "Inspections Before Trouble Diagnosis"](#).

OK or NG

OK >> GO TO 7.

NG-1 >> Line pressure high: GO TO 5.

NG-2 >> Line pressure low: GO TO 6.

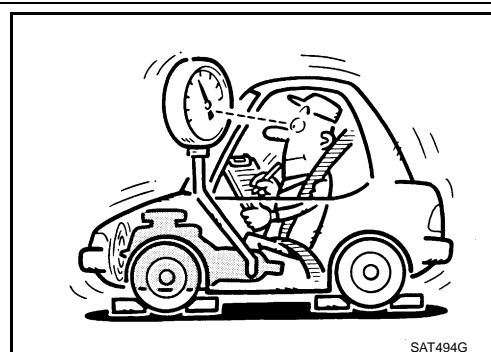

## 5.DETECT MALFUNCTIONING ITEM

1. Check control valve with TCM. Refer to [AT-215, "Control Valve with TCM and A/T Fluid Temperature Sensor 2"](#).
2. Disassemble A/T. Refer to [AT-267](#).
3. Check the following.
  - Oil pump assembly. Refer to [AT-285, "Oil Pump"](#).

OK or NG

OK >> GO TO 7.

NG >> Repair or replace damaged parts.

## 6.DETECT MALFUNCTIONING ITEM

1. Check control valve with TCM. Refer to [AT-215, "Control Valve with TCM and A/T Fluid Temperature Sensor 2"](#).
2. Disassemble A/T. Refer to [AT-267](#).
3. Check the following.
  - Oil pump assembly. Refer to [AT-285, "Oil Pump"](#).
  - Power train system. Refer to [AT-267](#).
  - Transmission case. Refer to [AT-267](#).

OK or NG

OK >> GO TO 7.

NG >> Repair or replace damaged parts.

# TROUBLE DIAGNOSIS FOR SYMPTOMS

< SERVICE INFORMATION >

## 7. CHECK A/T FLUID CONDITION

1. Remove oil pan. Refer to [AT-215, "Control Valve with TCM and A/T Fluid Temperature Sensor 2"](#).
2. Check A/T fluid condition. Refer to [AT-49, "Inspections Before Trouble Diagnosis"](#).

OK or NG

- OK >> GO TO 8.  
NG >> GO TO 11.

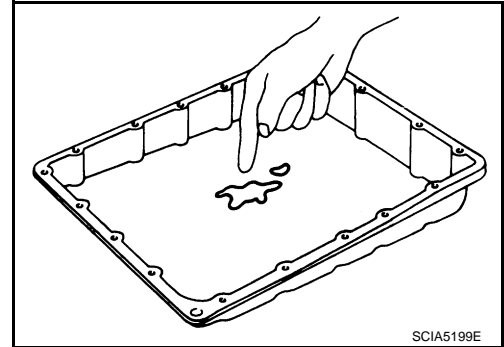

## 8. DETECT MALFUNCTIONING ITEM

Check the malfunction items. If any items are damaged, repair or replace damaged parts. Refer to [AT-59, "Symptom Chart"](#) (Symptom No.12).

OK or NG

- OK >> GO TO 9.  
NG >> Repair or replace damaged parts.

## 9. CHECK SYMPTOM

Check again. Refer to [AT-53, "Road Test"](#).

OK or NG

- OK >> **INSPECTION END**  
NG >> GO TO 10.

## 10. CHECK TCM

1. Check TCM input/output signals. Refer to [AT-83, "TCM Input/Output Signal Reference Value"](#).
2. If NG, recheck A/T assembly harness connector terminals for damage or loose connection with harness connector.

OK or NG

- OK >> **INSPECTION END**  
NG >> Repair or replace damaged parts.

## 11. DETECT MALFUNCTIONING ITEM

Check the malfunction items. If any items are damaged, repair or replace damaged parts. Refer to [AT-59, "Symptom Chart"](#) (Symptom No.12).

OK or NG

- OK >> GO TO 9.  
NG >> Repair or replace damaged parts.

A/T Does Not Shift: D4→D5

INFOID:000000001327372

SYMPTOM:

- The vehicle does not shift-up from the D4 to D5 gear at the specified speed.
- The vehicle does not shift-up from the D4 to D5 gear unless A/T is warmed up.

DIAGNOSTIC PROCEDURE

### 1. CONFIRM THE SYMPTOM

Check if vehicle creeps forward in "D" position and vehicle can be started from D1.

OK or NG

- OK >> GO TO 2.  
NG >> Refer to [AT-178, "Vehicle Does Not Creep Forward in "D" Position"](#), [AT-180, "Vehicle Cannot Be Started from D1"](#).

### 2. CHECK SELF-DIAGNOSTIC RESULTS

# TROUBLE DIAGNOSIS FOR SYMPTOMS

## < SERVICE INFORMATION >

### With CONSULT-III

- Perform self-diagnosis.

### Without CONSULT-III

- Perform self-diagnosis. Refer to [AT-91, "Diagnosis Procedure without CONSULT-III"](#).

Is any malfunction detected by self-diagnostic results?

YES >> Check the malfunctioning system. Refer to [AT-84, "CONSULT-III Function \(TRANSMISSION\)"](#), [AT-91, "Diagnosis Procedure without CONSULT-III"](#).

NO >> GO TO 3.

## 3.CHECK A/T FLUID LEVEL

Check A/T fluid level. Refer to [AT-11, "Checking A/T Fluid"](#).

OK or NG

- OK >> GO TO 4.
- NG >> Refill ATF.

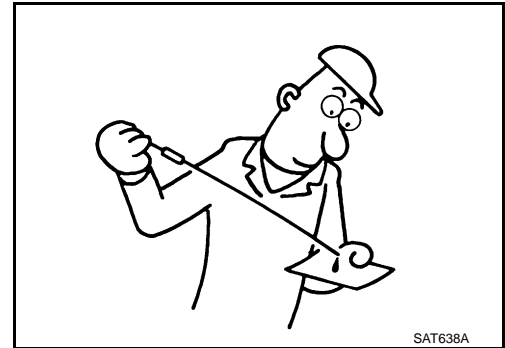

## 4.CHECK LINE PRESSURE

Check line pressure at the engine stall point. Refer to [AT-49, "Inspections Before Trouble Diagnosis"](#).

OK or NG

- OK >> GO TO 7.
- NG-1 >> Line pressure high: GO TO 5.
- NG-2 >> Line pressure low: GO TO 6.

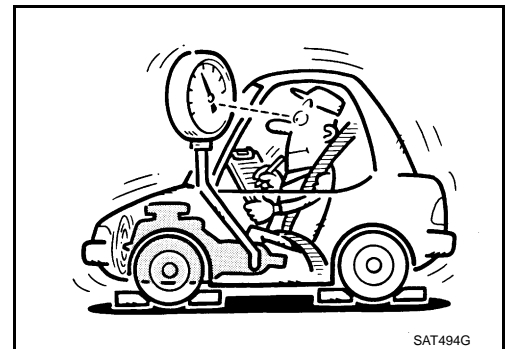

## 5.DETECT MALFUNCTIONING ITEM

1. Check control valve with TCM. Refer to [AT-215, "Control Valve with TCM and A/T Fluid Temperature Sensor 2"](#).
2. Disassemble A/T. Refer to [AT-267](#).
3. Check the following.
  - Oil pump assembly. Refer to [AT-285, "Oil Pump"](#).

OK or NG

- OK >> GO TO 7.
- NG >> Repair or replace damaged parts.

## 6.DETECT MALFUNCTIONING ITEM

1. Check control valve with TCM. Refer to [AT-215, "Control Valve with TCM and A/T Fluid Temperature Sensor 2"](#).
2. Disassemble A/T. Refer to [AT-267](#).
3. Check the following.
  - Oil pump assembly. Refer to [AT-285, "Oil Pump"](#).
  - Power train system. Refer to [AT-267](#).
  - Transmission case. Refer to [AT-267](#).

OK or NG

- OK >> GO TO 7.
- NG >> Repair or replace damaged parts.

# TROUBLE DIAGNOSIS FOR SYMPTOMS

< SERVICE INFORMATION >

## 7. CHECK A/T FLUID CONDITION

1. Remove oil pan. Refer to [AT-215, "Control Valve with TCM and A/T Fluid Temperature Sensor 2"](#).
2. Check A/T fluid condition. Refer to [AT-49, "Inspections Before Trouble Diagnosis"](#).

OK or NG

- OK >> GO TO 8.  
NG >> GO TO 11.

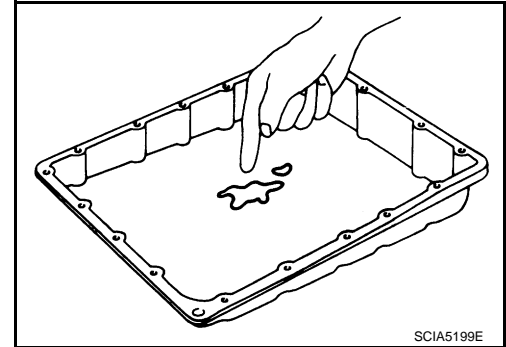

SCIA5199E

## 8. DETECT MALFUNCTIONING ITEM

Check the malfunction items. If any items are damaged, repair or replace damaged parts. Refer to [AT-59, "Symptom Chart"](#) (Symptom No.13).

OK or NG

- OK >> GO TO 9.  
NG >> Repair or replace damaged parts.

## 9. CHECK SYMPTOM

Check again. Refer to [AT-53, "Road Test"](#).

OK or NG

- OK >> **INSPECTION END**  
NG >> GO TO 10.

## 10. CHECK TCM

1. Check TCM input/output signals. Refer to [AT-83, "TCM Input/Output Signal Reference Value"](#).
2. If NG, recheck A/T assembly harness connector terminals for damage or loose connection with harness connector.

OK or NG

- OK >> **INSPECTION END**  
NG >> Repair or replace damaged parts.

## 11. DETECT MALFUNCTIONING ITEM

Check the malfunction items. If any items are damaged, repair or replace damaged parts. Refer to [AT-59, "Symptom Chart"](#) (Symptom No.13).

OK or NG

- OK >> GO TO 9.  
NG >> Repair or replace damaged parts.

## A/T Does Not Lock-up

INFOID:000000001327373

SYMPTOM:

**A/T does not lock-up at the specified speed.**

DIAGNOSTIC PROCEDURE

### 1. CHECK SELF-DIAGNOSTIC RESULTS

**With CONSULT-III**

- Perform self-diagnosis.

**Without CONSULT-III**

- Perform self-diagnosis. Refer to [AT-91, "Diagnosis Procedure without CONSULT-III"](#).

Is any malfunction detected by self-diagnostic results?

# TROUBLE DIAGNOSIS FOR SYMPTOMS

## < SERVICE INFORMATION >

- YES >> Check the malfunctioning system. Refer to [AT-84, "CONSULT-III Function \(TRANSMISSION\)"](#),  
[AT-91, "Diagnosis Procedure without CONSULT-III"](#).
- NO >> GO TO 2.

## 2.CHECK A/T FLUID LEVEL

Check A/T fluid level. Refer to [AT-11, "Checking A/T Fluid"](#).

### OK or NG

- OK >> GO TO 3.  
NG >> Refill ATF.

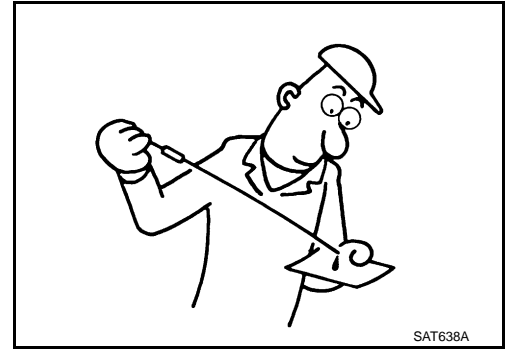

## 3.CHECK LINE PRESSURE

Check line pressure at the engine stall point. Refer to [AT-49, "Inspections Before Trouble Diagnosis"](#).

### OK or NG

- OK >> GO TO 6.  
NG-1 >> Line pressure high: GO TO 4.  
NG-2 >> Line pressure low: GO TO 5.

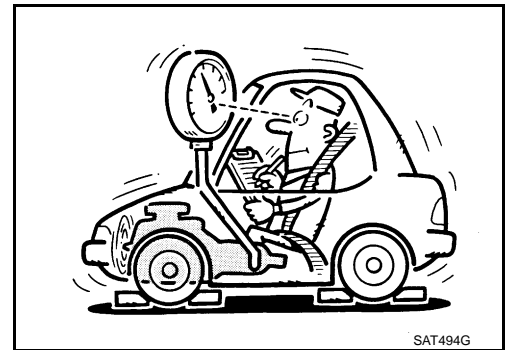

## 4.DETECT MALFUNCTIONING ITEM

1. Check control valve with TCM. Refer to [AT-215, "Control Valve with TCM and A/T Fluid Temperature Sensor 2"](#).
2. Disassemble A/T. Refer to [AT-267](#).
3. Check the following.
  - Oil pump assembly. Refer to [AT-285, "Oil Pump"](#).

### OK or NG

- OK >> GO TO 6.  
NG >> Repair or replace damaged parts.

## 5.DETECT MALFUNCTIONING ITEM

1. Check control valve with TCM. Refer to [AT-215, "Control Valve with TCM and A/T Fluid Temperature Sensor 2"](#).
2. Disassemble A/T. Refer to [AT-267](#).
3. Check the following.
  - Oil pump assembly. Refer to [AT-285, "Oil Pump"](#).
  - Power train system. Refer to [AT-267](#).
  - Transmission case. Refer to [AT-267](#).

### OK or NG

- OK >> GO TO 6.  
NG >> Repair or replace damaged parts.

## 6.CHECK A/T FLUID CONDITION

1. Remove oil pan. Refer to [AT-215, "Control Valve with TCM and A/T Fluid Temperature Sensor 2"](#).

## TROUBLE DIAGNOSIS FOR SYMPTOMS

< SERVICE INFORMATION >

2. Check A/T fluid condition. Refer to [AT-49, "Inspections Before Trouble Diagnosis"](#).

OK or NG

- OK >> GO TO 7.
- NG >> GO TO 10.

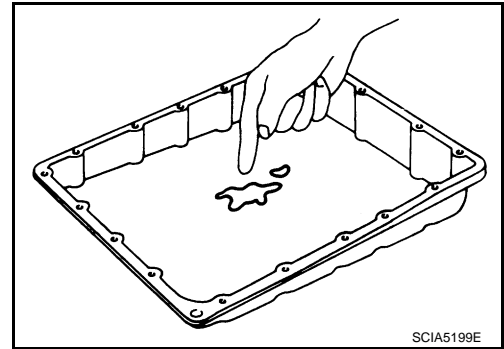

### 7. DETECT MALFUNCTIONING ITEM

Check the malfunction items. If any items are damaged, repair or replace damaged parts. Refer to [AT-59, "Symptom Chart"](#) (Symptom No.24).

OK or NG

- OK >> GO TO 8.
- NG >> Repair or replace damaged parts.

### 8. CHECK SYMPTOM

Check again. Refer to [AT-53, "Road Test"](#).

OK or NG

- OK >> **INSPECTION END**
- NG >> GO TO 9.

### 9. CHECK TCM

1. Check TCM input/output signals. Refer to [AT-83, "TCM Input/Output Signal Reference Value"](#).
2. If NG, recheck A/T assembly harness connector terminals for damage or loose connection with harness connector.

OK or NG

- OK >> **INSPECTION END**
- NG >> Repair or replace damaged parts.

### 10. DETECT MALFUNCTIONING ITEM

Check the malfunction items. If any items are damaged, repair or replace damaged parts. Refer to [AT-59, "Symptom Chart"](#) (Symptom No.24).

OK or NG

- OK >> GO TO 8.
- NG >> Repair or replace damaged parts.

## A/T Does Not Hold Lock-up Condition

INFOID:000000001327374

SYMPTOM:

**The lock-up condition cannot be maintained for more than 30 seconds.**

DIAGNOSTIC PROCEDURE

### 1. CHECK SELF-DIAGNOSTIC RESULTS

**With CONSULT-III**

- Perform self-diagnosis.

**Without CONSULT-III**

- Perform self-diagnosis. Refer to [AT-91, "Diagnosis Procedure without CONSULT-III"](#).

Is any malfunction detected by self-diagnostic results?

- YES >> Check the malfunctioning system. Refer to [AT-84, "CONSULT-III Function \(TRANSMISSION\)"](#), [AT-91, "Diagnosis Procedure without CONSULT-III"](#).
- NO >> GO TO 2.



# TROUBLE DIAGNOSIS FOR SYMPTOMS

< SERVICE INFORMATION >

## 2. CHECK A/T FLUID LEVEL

Check A/T fluid level. Refer to [AT-11, "Checking A/T Fluid"](#).

OK or NG

- OK >> GO TO 3.
- NG >> Refill ATF.

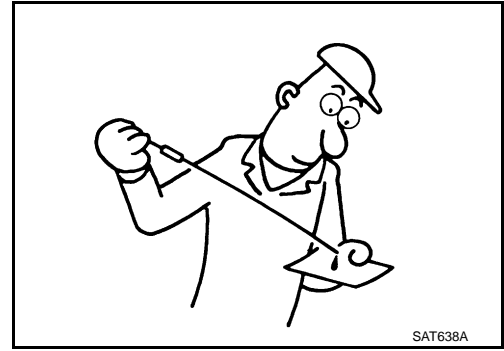

## 3. CHECK A/T FLUID CONDITION

1. Remove oil pan. Refer to [AT-215, "Control Valve with TCM and A/T Fluid Temperature Sensor 2"](#).
2. Check A/T fluid condition. Refer to [AT-49, "Inspections Before Trouble Diagnosis"](#).

OK or NG

- OK >> GO TO 4.
- NG >> GO TO 7.

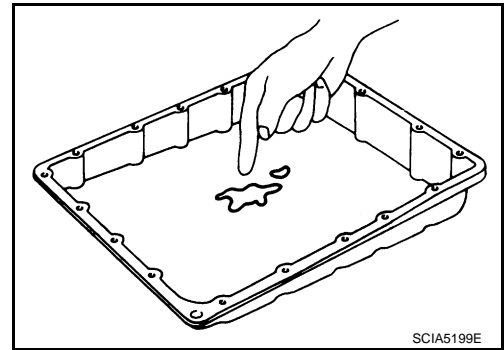

## 4. DETECT MALFUNCTIONING ITEM

Check the malfunction items. If any items are damaged, repair or replace damaged parts. Refer to [AT-59, "Symptom Chart"](#) (Symptom No.25).

OK or NG

- OK >> GO TO 5.
- NG >> Repair or replace damaged parts.

## 5. CHECK SYMPTOM

Check again. Refer to [AT-53, "Road Test"](#).

OK or NG

- OK >> **INSPECTION END**
- NG >> GO TO 6.

## 6. CHECK TCM

1. Check TCM input/output signals. Refer to [AT-83, "TCM Input/Output Signal Reference Value"](#).
2. If NG, recheck A/T assembly harness connector terminals for damage or loose connection with harness connector.

OK or NG

- OK >> **INSPECTION END**
- NG >> Repair or replace damaged parts.

## 7. DETECT MALFUNCTIONING ITEM

Check the malfunction items. If any items are damaged, repair or replace damaged parts. Refer to [AT-59, "Symptom Chart"](#) (Symptom No.25).

OK or NG

- OK >> GO TO 5.
- NG >> Repair or replace damaged parts.

A  
B  
AT  
D  
E  
F  
G  
H  
I  
J  
K  
L  
M  
N  
O  
P

## TROUBLE DIAGNOSIS FOR SYMPTOMS

< SERVICE INFORMATION >

### Lock-up Is Not Released

INFOID:000000001327375

SYMPTOM:

The lock-up condition cannot be cancelled even after releasing the accelerator pedal.

DIAGNOSTIC PROCEDURE

#### 1. CHECK SELF-DIAGNOSTIC RESULTS

##### With CONSULT-III

- Perform self-diagnosis.

##### Without CONSULT-III

- Perform self-diagnosis. Refer to [AT-91, "Diagnosis Procedure without CONSULT-III"](#).

Is any malfunction detected by self-diagnostic results?

YES >> Check the malfunctioning system. Refer to [AT-84, "CONSULT-III Function \(TRANSMISSION\)"](#), [AT-91, "Diagnosis Procedure without CONSULT-III"](#).

NO >> GO TO 2.

#### 2. CHECK SYMPTOM

Check again. Refer to [AT-53, "Road Test"](#).

OK or NG

OK >> **INSPECTION END**

NG >> GO TO 3.

#### 3. CHECK TCM

1. Check TCM input/output signals. Refer to [AT-83, "TCM Input/Output Signal Reference Value"](#).
2. If NG, recheck A/T assembly harness connector terminals for damage or loose connection with harness connector.

OK or NG

OK >> **INSPECTION END**

NG >> Repair or replace damaged parts.

### Engine Speed Does Not Return to Idle

INFOID:000000001327376

SYMPTOM:

When a shift-down is performed, the engine speed does not smoothly return to the idling speed.

DIAGNOSTIC PROCEDURE

#### 1. CHECK A/T FLUID LEVEL

Check A/T fluid level. Refer to [AT-11, "Checking A/T Fluid"](#).

OK or NG

OK >> GO TO 2.

NG >> Refill ATF.

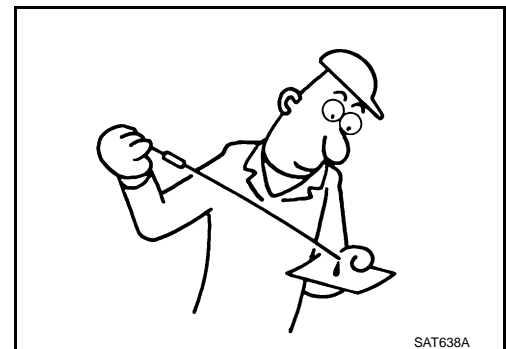

#### 2. CHECK SELF-DIAGNOSTIC RESULTS

##### With CONSULT-III

- Perform self-diagnosis.

##### Without CONSULT-III

- Perform self-diagnosis. Refer to [AT-91, "Diagnosis Procedure without CONSULT-III"](#).

# TROUBLE DIAGNOSIS FOR SYMPTOMS

## < SERVICE INFORMATION >

Is any malfunction detected by self-diagnostic results?

YES >> Check the malfunctioning system. Refer to [AT-84, "CONSULT-III Function \(TRANSMISSION\)"](#), [AT-91, "Diagnosis Procedure without CONSULT-III"](#).

NO >> GO TO 3.

### 3.CHECK A/T FLUID CONDITION

1. Remove oil pan. Refer to [AT-215, "Control Valve with TCM and A/T Fluid Temperature Sensor 2"](#).
2. Check A/T fluid condition. Refer to [AT-49, "Inspections Before Trouble Diagnosis"](#).

OK or NG

OK >> GO TO 4.

NG >> GO TO 7.

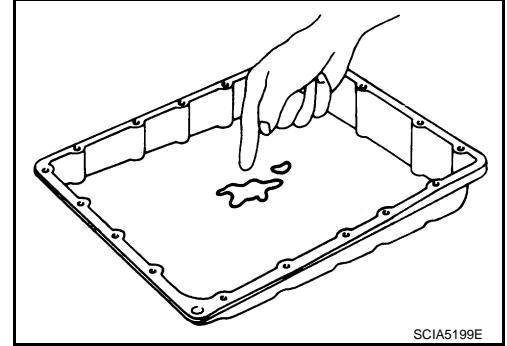

### 4.DETECT MALFUNCTIONING ITEM

Check the malfunction items. If any items are damaged, repair or replace damaged parts. Refer to [AT-59, "Symptom Chart"](#) (Symptom No.72).

OK or NG

OK >> GO TO 5.

NG >> Repair or replace damaged parts.

### 5.CHECK SYMPTOM

Check again. Refer to [AT-53, "Road Test"](#).

OK or NG

OK >> **INSPECTION END**

NG >> GO TO 6.

### 6.CHECK TCM

1. Check TCM input/output signals. Refer to [AT-83, "TCM Input/Output Signal Reference Value"](#).
2. If NG, recheck A/T assembly harness connector terminals for damage or loose connection with harness connector.

OK or NG

OK >> **INSPECTION END**

NG >> Repair or replace damaged parts.

### 7.DETECT MALFUNCTIONING ITEM

Check the malfunction items. If any items are damaged, repair or replace damaged parts. Refer to [AT-59, "Symptom Chart"](#) (Symptom No.72).

OK or NG

OK >> GO TO 5.

NG >> Repair or replace damaged parts.

## Cannot Be Changed to Manual Mode

INFOID:000000001327377

SYMPTOM:

**Does not change to manual mode when manual shift gate is used.**

DIAGNOSTIC PROCEDURE

### 1.CHECK MANUAL MODE SWITCH

Check the manual mode switch. Refer to [AT-155](#).

OK or NG

OK >> GO TO 2.

# TROUBLE DIAGNOSIS FOR SYMPTOMS

## < SERVICE INFORMATION >

NG >> Repair or replace damaged parts.

### 2.CHECK SELF-DIAGNOSIS RESULTS

#### With CONSULT-III

- Perform self-diagnosis.

#### Without CONSULT-III

- Perform self-diagnosis. Refer to [AT-91, "Diagnosis Procedure without CONSULT-III"](#).

Is any malfunction detected by self-diagnostic results?

YES >> Check the malfunctioning system. Refer to [AT-84, "CONSULT-III Function \(TRANSMISSION\)"](#), [AT-91, "Diagnosis Procedure without CONSULT-III"](#).

NO >> **INSPECTION END**

A/T Does Not Shift: 5th Gear → 4th Gear

INFOID:000000001327378

SYMPTOM:

**When shifted from M5 to M4 position in manual mode, does not downshift from 5th to 4th gear.**

DIAGNOSTIC PROCEDURE

### 1.CHECK SELF-DIAGNOSTIC RESULTS

#### With CONSULT-III

- Perform self-diagnosis.

#### Without CONSULT-III

- Perform self-diagnosis. Refer to [AT-91, "Diagnosis Procedure without CONSULT-III"](#).

Is any malfunction detected by self-diagnostic results?

YES >> Check the malfunctioning system. Refer to [AT-84, "CONSULT-III Function \(TRANSMISSION\)"](#), [AT-91, "Diagnosis Procedure without CONSULT-III"](#).

NO >> GO TO 2.

### 2.CHECK A/T FLUID LEVEL

Check A/T fluid level. Refer to [AT-11, "Checking A/T Fluid"](#).

OK or NG

OK >> GO TO 3.

NG >> Refill ATF.

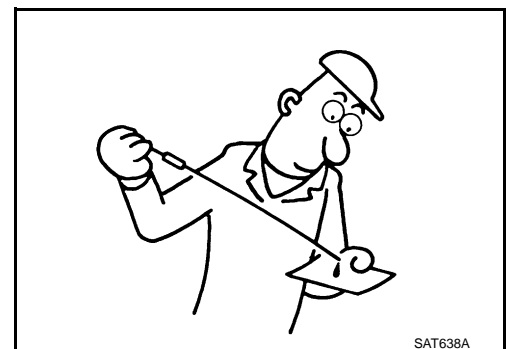

### 3.CHECK A/T POSITION

Check the A/T position. Refer to [AT-207, "Checking of A/T Position"](#).

OK or NG

OK >> GO TO 4.

NG >> Adjust A/T position. Refer to [AT-207, "Adjustment of A/T Position"](#).

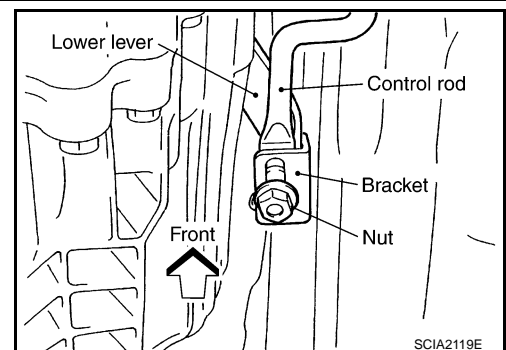

### 4.CHECK MANUAL MODE SWITCH

# TROUBLE DIAGNOSIS FOR SYMPTOMS

## < SERVICE INFORMATION >

Check the manual mode switch. Refer to [AT-155](#).

### OK or NG

- OK >> GO TO 5.
- NG >> Repair or replace damaged parts.

## 5. CHECK A/T FLUID CONDITION

1. Remove oil pan. Refer to [AT-215, "Control Valve with TCM and A/T Fluid Temperature Sensor 2"](#).
2. Check A/T fluid condition. Refer to [AT-49, "Inspections Before Trouble Diagnosis"](#).

### OK or NG

- OK >> GO TO 6.
- NG >> GO TO 9.

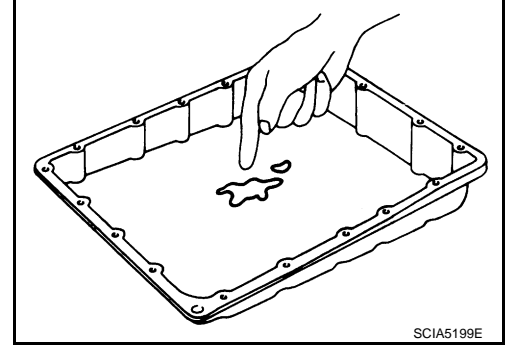

## 6. DETECT MALFUNCTIONING ITEM

Check the malfunction items. If any items are damaged, repair or replace damaged parts. Refer to [AT-59, "Symptom Chart"](#) (Symptom No.47).

### OK or NG

- OK >> GO TO 7.
- NG >> Repair or replace damaged parts.

## 7. CHECK SYMPTOM

Check again. Refer to [AT-53, "Road Test"](#).

### OK or NG

- OK >> **INSPECTION END**
- NG >> GO TO 8.

## 8. CHECK TCM

1. Check TCM input/output signals. Refer to [AT-83, "TCM Input/Output Signal Reference Value"](#).
2. If NG, recheck A/T assembly harness connector terminals for damage or loose connection with harness connector.

### OK or NG

- OK >> **INSPECTION END**
- NG >> Repair or replace damaged parts.

## 9. DETECT MALFUNCTIONING ITEM

Check the malfunction items. If any items are damaged, repair or replace damaged parts. Refer to [AT-59, "Symptom Chart"](#) (Symptom No.47).

### OK or NG

- OK >> GO TO 7.
- NG >> Repair or replace damaged parts.

## A/T Does Not Shift: 4th Gear → 3rd Gear

INFOID:000000001327379

### SYMPTOM:

**When shifted from M4 to M3 position in manual mode, does not downshift from 4th to 3rd gear.**

### DIAGNOSTIC PROCEDURE

## 1. CHECK SELF-DIAGNOSTIC RESULTS

### With CONSULT-III

- Perform self-diagnosis.

# TROUBLE DIAGNOSIS FOR SYMPTOMS

< SERVICE INFORMATION >

## ⊗ Without CONSULT-III

- Perform self-diagnosis. Refer to [AT-91, "Diagnosis Procedure without CONSULT-III"](#).

Is any malfunction detected by self-diagnostic results?

YES >> Check the malfunctioning system. Refer to [AT-84, "CONSULT-III Function \(TRANSMISSION\)"](#),  
[AT-91, "Diagnosis Procedure without CONSULT-III"](#).

NO >> GO TO 2.

## 2.CHECK A/T FLUID LEVEL

Check A/T fluid level. Refer to [AT-11, "Checking A/T Fluid"](#).

OK or NG

OK >> GO TO 3.

NG >> Refill ATF.

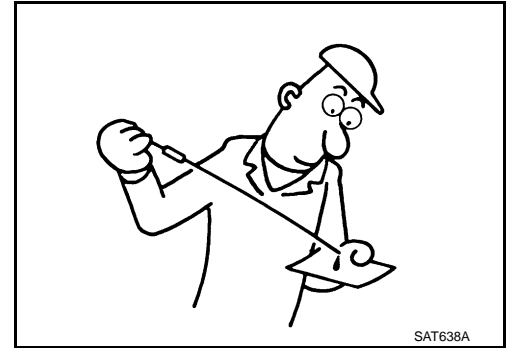

## 3.CHECK A/T POSITION

Check the A/T position. Refer to [AT-207, "Checking of A/T Position"](#).

OK or NG

OK >> GO TO 4.

NG >> Adjust A/T position. Refer to [AT-207, "Adjustment of A/T Position"](#).

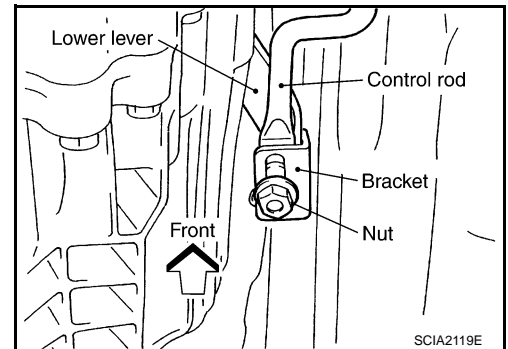

## 4.CHECK MANUAL MODE SWITCH

Check the manual mode switch. Refer to [AT-155](#).

OK or NG

OK >> GO TO 5.

NG >> Repair or replace damaged parts.

## 5.CHECK A/T FLUID CONDITION

1. Remove oil pan. Refer to [AT-215, "Control Valve with TCM and A/T Fluid Temperature Sensor 2"](#).

2. Check A/T fluid condition. Refer to [AT-49, "Inspections Before Trouble Diagnosis"](#).

OK or NG

OK >> GO TO 6.

NG >> GO TO 9.

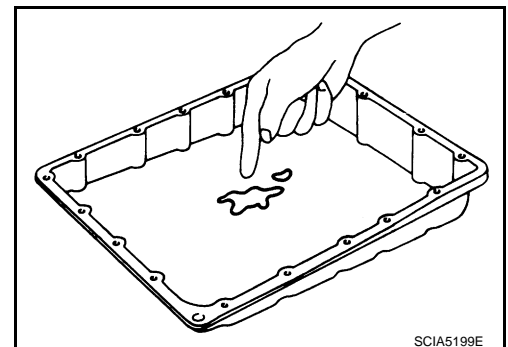

## 6.DETECT MALFUNCTIONING ITEM

Check the malfunction items. If any items are damaged, repair or replace damaged parts. Refer to [AT-59, "Symptom Chart"](#) (Symptom No.48).

OK or NG

OK >> GO TO 7.

# TROUBLE DIAGNOSIS FOR SYMPTOMS

## < SERVICE INFORMATION >

NG >> Repair or replace damaged parts.

### 7.CHECK SYMPTOM

Check again. Refer to [AT-53, "Road Test"](#).

#### OK or NG

OK >> **INSPECTION END**

NG >> GO TO 8.

### 8.CHECK TCM

1. Check TCM input/output signals. Refer to [AT-83, "TCM Input/Output Signal Reference Value"](#).
2. If NG, recheck A/T assembly harness connector terminals for damage or loose connection with harness connector.

#### OK or NG

OK >> **INSPECTION END**

NG >> Repair or replace damaged parts.

### 9.DETECT MALFUNCTIONING ITEM

Check the malfunction items. If any items are damaged, repair or replace damaged parts. Refer to [AT-59, "Symptom Chart"](#) (Symptom No.48).

#### OK or NG

OK >> GO TO 7.

NG >> Repair or replace damaged parts.

## A/T Does Not Shift: 3rd Gear → 2nd Gear

INFOID:000000001327380

### SYMPTOM:

**When shifted from M3 to M2 position in manual mode, does not downshift from 3rd to 2nd gear.**

### DIAGNOSTIC PROCEDURE

#### 1.CHECK SELF-DIAGNOSTIC RESULTS

##### With CONSULT-III

- Perform self-diagnosis.

##### Without CONSULT-III

- Perform self-diagnosis. Refer to [AT-91, "Diagnosis Procedure without CONSULT-III"](#).

Is any malfunction detected by self-diagnostic results?

YES >> Check the malfunctioning system. Refer to [AT-84, "CONSULT-III Function \(TRANSMISSION\)"](#), [AT-91, "Diagnosis Procedure without CONSULT-III"](#).

NO >> GO TO 2.

#### 2.CHECK A/T FLUID LEVEL

Check A/T fluid level. Refer to [AT-11, "Checking A/T Fluid"](#).

#### OK or NG

OK >> GO TO 3.

NG >> Refill ATF.

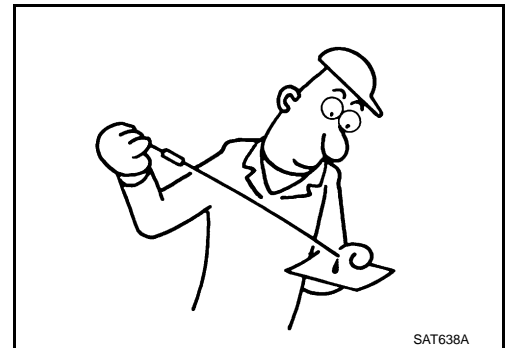

#### 3.CHECK A/T POSITION

# TROUBLE DIAGNOSIS FOR SYMPTOMS

## < SERVICE INFORMATION >

Check the A/T position. Refer to [AT-207, "Checking of A/T Position"](#).

### OK or NG

- OK >> GO TO 4.
- NG >> Adjust A/T position. Refer to [AT-207, "Adjustment of A/T Position"](#).

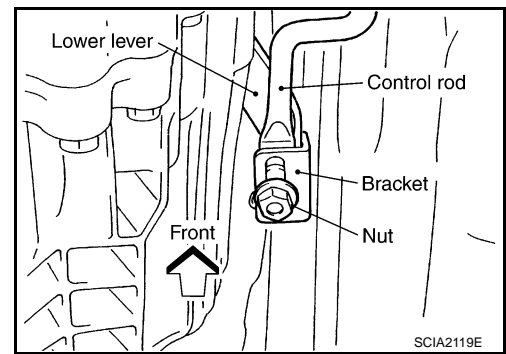

## 4. CHECK MANUAL MODE SWITCH

Check the manual mode switch. Refer to [AT-155](#).

### OK or NG

- OK >> GO TO 5.
- NG >> Repair or replace damaged parts.

## 5. CHECK A/T FLUID CONDITION

1. Remove oil pan. Refer to [AT-215, "Control Valve with TCM and A/T Fluid Temperature Sensor 2"](#).
2. Check A/T fluid condition. Refer to [AT-49, "Inspections Before Trouble Diagnosis"](#).

### OK or NG

- OK >> GO TO 6.
- NG >> GO TO 9.

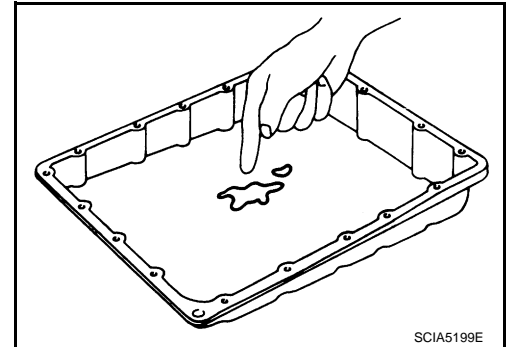

## 6. DETECT MALFUNCTIONING ITEM

Check the malfunction items. If any items are damaged, repair or replace damaged parts. Refer to [AT-59, "Symptom Chart"](#) (Symptom No.49).

### OK or NG

- OK >> GO TO 7.
- NG >> Repair or replace damaged parts.

## 7. CHECK SYMPTOM

Check again. Refer to [AT-53, "Road Test"](#).

### OK or NG

- OK >> **INSPECTION END**
- NG >> GO TO 8.

## 8. CHECK TCM

1. Check TCM input/output signals. Refer to [AT-83, "TCM Input/Output Signal Reference Value"](#).
2. If NG, recheck A/T assembly harness connector terminals for damage or loose connection with harness connector.

### OK or NG

- OK >> **INSPECTION END**
- NG >> Repair or replace damaged parts.

## 9. DETECT MALFUNCTIONING ITEM

Check the malfunction items. If any items are damaged, repair or replace damaged parts. Refer to [AT-59, "Symptom Chart"](#) (Symptom No.49).

### OK or NG

- OK >> GO TO 7.



# TROUBLE DIAGNOSIS FOR SYMPTOMS

## < SERVICE INFORMATION >

NG >> Repair or replace damaged parts.

### A/T Does Not Shift: 2nd Gear → 1st Gear

INFOID:000000001327381

#### SYMPTOM:

When shifted from M2 to M1 position in manual mode, does not downshift from 2nd to 1st gear.

#### DIAGNOSTIC PROCEDURE

### 1. CHECK SELF-DIAGNOSTIC RESULTS

#### With CONSULT-III

- Perform self-diagnosis.

#### Without CONSULT-III

- Perform self-diagnosis. Refer to [AT-91, "Diagnosis Procedure without CONSULT-III"](#).

#### Is any malfunction detected by self-diagnostic results?

YES >> Check the malfunctioning system. Refer to [AT-84, "CONSULT-III Function \(TRANSMISSION\)"](#), [AT-91, "Diagnosis Procedure without CONSULT-III"](#).

NO >> GO TO 2.

### 2. CHECK A/T FLUID LEVEL

Check A/T fluid level. Refer to [AT-11, "Checking A/T Fluid"](#).

#### OK or NG

OK >> GO TO 3.  
NG >> Refill ATF.

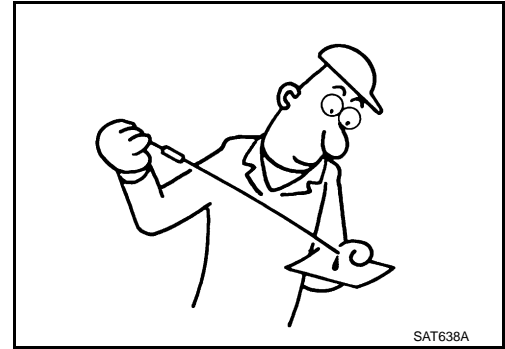

### 3. CHECK A/T POSITION

Check the A/T position. Refer to [AT-207, "Checking of A/T Position"](#).

#### OK or NG

OK >> GO TO 4.  
NG >> Adjust A/T position. Refer to [AT-207, "Adjustment of A/T Position"](#).

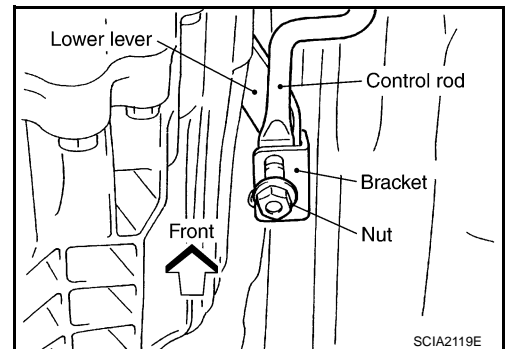

### 4. CHECK MANUAL MODE SWITCH

Check the manual mode switch. Refer to [AT-155](#).

#### OK or NG

OK >> GO TO 5.  
NG >> Repair or replace damaged parts.

### 5. CHECK A/T FLUID CONDITION

1. Remove oil pan. Refer to [AT-215, "Control Valve with TCM and A/T Fluid Temperature Sensor 2"](#).

## TROUBLE DIAGNOSIS FOR SYMPTOMS

< SERVICE INFORMATION >

2. Check A/T fluid condition. Refer to [AT-49, "Inspections Before Trouble Diagnosis"](#).

OK or NG

- OK >> GO TO 6.
- NG >> GO TO 9.

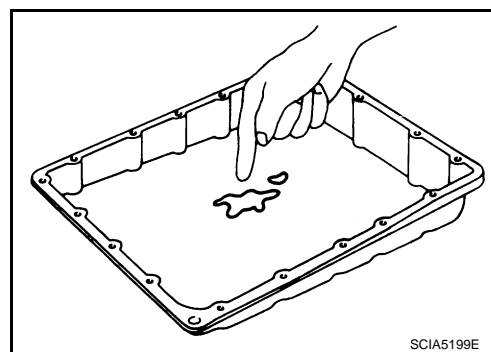

### 6. DETECT MALFUNCTIONING ITEM

Check the malfunction items. If any items are damaged, repair or replace damaged parts. Refer to [AT-59, "Symptom Chart"](#) (Symptom No.50).

OK or NG

- OK >> GO TO 7.
- NG >> Repair or replace damaged parts.

### 7. CHECK SYMPTOM

Check again. Refer to [AT-53, "Road Test"](#).

OK or NG

- OK >> **INSPECTION END**
- NG >> GO TO 8.

### 8. CHECK TCM

1. Check TCM input/output signals. Refer to [AT-83, "TCM Input/Output Signal Reference Value"](#).
2. If NG, recheck A/T assembly harness connector terminals for damage or loose connection with harness connector.

OK or NG

- OK >> **INSPECTION END**
- NG >> Repair or replace damaged parts.

### 9. DETECT MALFUNCTIONING ITEM

Check the malfunction items. If any items are damaged, repair or replace damaged parts. Refer to [AT-59, "Symptom Chart"](#) (Symptom No.50).

OK or NG

- OK >> GO TO 7.
- NG >> Repair or replace damaged parts.

## Vehicle Does Not Decelerate by Engine Brake

INFOID:000000001327382

SYMPTOM:

**No engine brake is applied when the gear is shifted from the 2nd to 1st gear.**

DIAGNOSTIC PROCEDURE

### 1. CHECK SELF-DIAGNOSTIC RESULTS

**With CONSULT-III**

- Perform self-diagnosis.

**Without CONSULT-III**

- Perform self-diagnosis. Refer to [AT-91, "Diagnosis Procedure without CONSULT-III"](#).

Is any malfunction detected by self-diagnostic results?

- YES >> Check the malfunctioning system. Refer to [AT-84, "CONSULT-III Function \(TRANSMISSION\)"](#), [AT-91, "Diagnosis Procedure without CONSULT-III"](#).
- NO >> GO TO 2.

# TROUBLE DIAGNOSIS FOR SYMPTOMS

< SERVICE INFORMATION >

## 2. CHECK A/T FLUID LEVEL

Check A/T fluid level. Refer to [AT-11, "Checking A/T Fluid"](#).

OK or NG

- OK >> GO TO 3.
- NG >> Refill ATF.

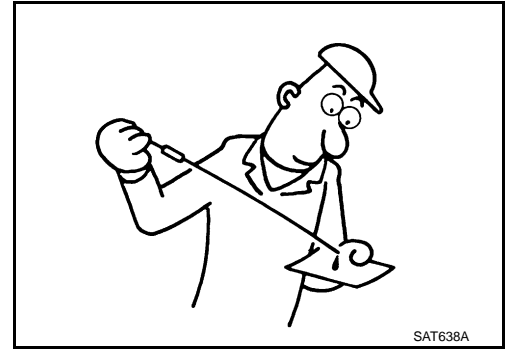

## 3. CHECK A/T POSITION

Check the A/T position. Refer to [AT-207, "Checking of A/T Position"](#).

OK or NG

- OK >> GO TO 4.
- NG >> Adjust A/T position. Refer to [AT-207, "Adjustment of A/T Position"](#).

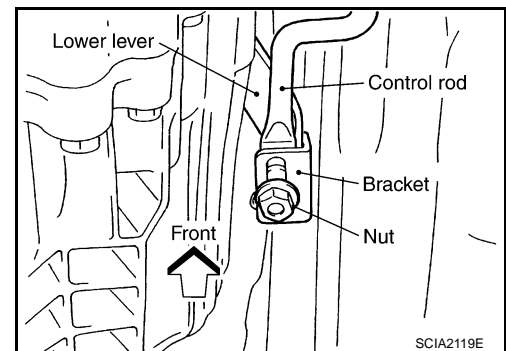

## 4. CHECK MANUAL MODE SWITCH

Check the manual mode switch. Refer to [AT-155](#).

OK or NG

- OK >> GO TO 5.
- NG >> Repair or replace damaged parts.

## 5. CHECK A/T FLUID CONDITION

1. Remove oil pan. Refer to [AT-215, "Control Valve with TCM and A/T Fluid Temperature Sensor 2"](#).
2. Check A/T fluid condition. Refer to [AT-49, "Inspections Before Trouble Diagnosis"](#).

OK or NG

- OK >> GO TO 6.
- NG >> GO TO 9.

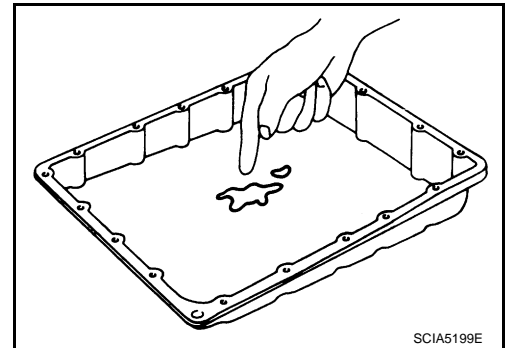

## 6. DETECT MALFUNCTIONING ITEM

Check the malfunction items. If any items are damaged, repair or replace damaged parts. Refer to [AT-59, "Symptom Chart"](#) (Symptom No.58).

OK or NG

- OK >> GO TO 7.
- NG >> Repair or replace damaged parts.

## 7. CHECK SYMPTOM

Check again. Refer to [AT-53, "Road Test"](#).

OK or NG

- OK >> **INSPECTION END**

A  
B  
AT  
D  
E  
F  
G  
H  
I  
J  
K  
L  
M  
N  
O  
P

## TROUBLE DIAGNOSIS FOR SYMPTOMS

### < SERVICE INFORMATION >

---

NG >> GO TO 8.

#### 8.CHECK TCM

---

1. Check TCM input/output signals. Refer to [AT-83, "TCM Input/Output Signal Reference Value"](#).
2. If NG, recheck A/T assembly harness connector terminals for damage or loose connection with harness connector.

#### OK or NG

OK >> **INSPECTION END**

NG >> Repair or replace damaged parts.

#### 9.DETECT MALFUNCTIONING ITEM

---

Check the malfunction items. If any items are damaged, repair or replace damaged parts. Refer to [AT-59, "Symptom Chart"](#) (Symptom No.58).

#### OK or NG

OK >> GO TO 7.

NG >> Repair or replace damaged parts.

# SHIFT CONTROL SYSTEM

< SERVICE INFORMATION >

## SHIFT CONTROL SYSTEM

### Control Device Removal and Installation

INFOID:000000001327383

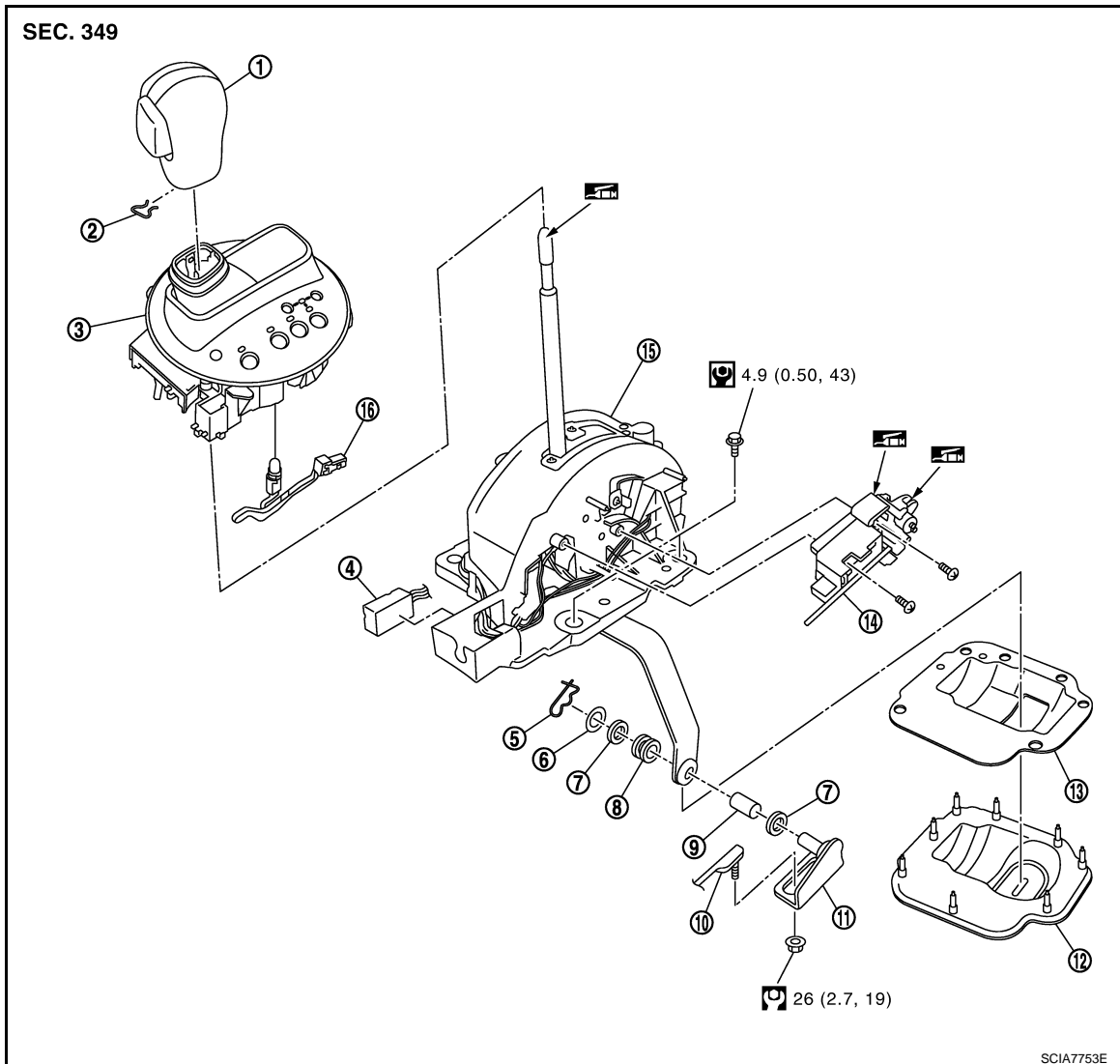

- |                                 |   |                             |
|---------------------------------|---|-----------------------------|
| 1. Selector lever knob          | 2. Lock pin   | 3. Position indicator plate |
| 4. A/T device harness connector | 5. Snap pin   | 6. Conical washer           |
| 7. Plain washer                 | 8. Busing   | 9. Collar                   |
| 10. Control rod                 | 11. Bracket   | 12. Dust cover              |
| 13. Dust cover plate            | 14. Shift lock solenoid and park position switch assembly | 15. Control device assembly |
| 16. Position lamp               |   |                             |

Refer to GI section to make sure icons (symbol marks) in the figure. Refer to [GI-8. "Component"](#).

#### REMOVAL

#### **CAUTION:**

**Make sure that parking brake is applied before removal/installation.**

1. Disconnect lower lever of control device and control rod.

# SHIFT CONTROL SYSTEM

## < SERVICE INFORMATION >

2. Remove knob cover (1) below selector lever downward.
3. Pull lock pin (2) out of selector lever knob (3).
4. Remove selector lever knob (3).
5. Remove A/T console finisher. Refer to [IP-10, "Component Parts Location"](#).
6. Remove center console. Refer to [IP-10, "Component Parts Location"](#).
7. Remove rear ventilator duct 2. Refer to [ATC-116, "Removal and Installation"](#).
8. Remove key interlock cable (1) from control device. Refer to [AT-212, "Removal and Installation"](#).
9. Disconnect A/T device harness connector (2).
10. Remove control device assembly.

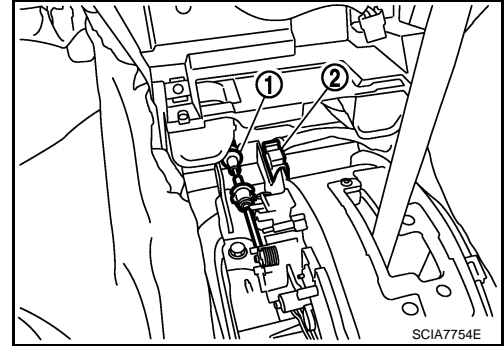
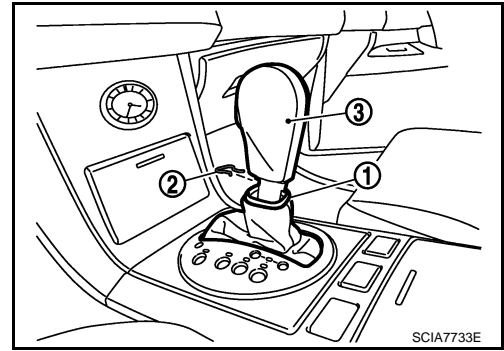

## INSTALLATION

Install in reverse order of removal. Be careful of the following:

- After installation is completed, adjust and check A/T position. Refer to [AT-207, "Adjustment of A/T Position"](#) and [AT-207, "Checking of A/T Position"](#).

## Control Rod Removal and Installation

INFOID:000000001327384

## CONTROL ROD COMPONENTS

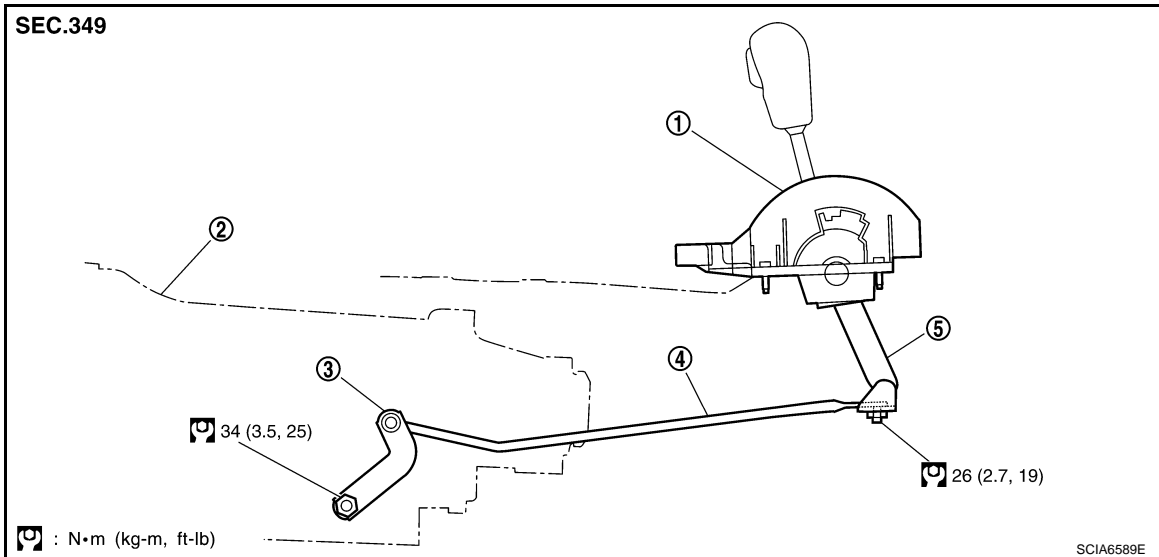

- |                            |                 |                 |
|----------------------------|-----------------|-----------------|
| 1. Control device assembly | 2. A/T assembly | 3. Manual lever |
| 4. Control rod             | 5. Lower lever  |                 |

## REMOVAL

# SHIFT CONTROL SYSTEM

## < SERVICE INFORMATION >

1. Disconnect lower lever of control device and control rod.
2. Remove manual lever from A/T assembly.
3. Remove control rod from vehicle.

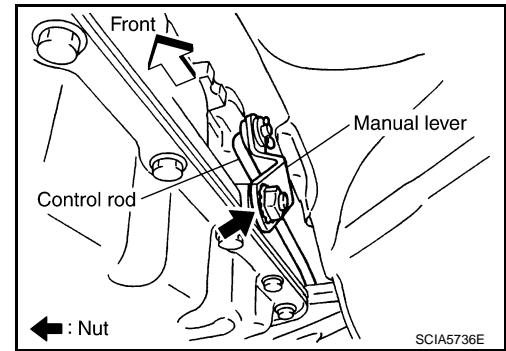

## INSTALLATION

Install in reverse order of removal. Be careful of the following:

- After installation is completed, adjust and check A/T position. Refer to [AT-207, "Adjustment of A/T Position"](#) and [AT-207, "Checking of A/T Position"](#).

## Adjustment of A/T Position

INFOID:000000001327385

1. Loosen nut of control rod.
2. Place PNP switch and selector lever in "P" position.
3. While pressing lower lever toward rear of vehicle (in "P" position direction), tighten nut to the specified torque. Refer to [AT-206, "Control Rod Removal and Installation"](#).

### CAUTION:

**Do not push the bracket.**

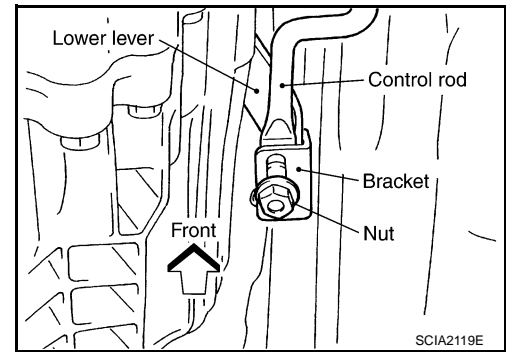

## Checking of A/T Position

INFOID:000000001327386

1. Place selector lever in "P" position, and turn ignition switch ON.
2. Check selector lever can be shifted to other than "P" position when brake pedal is depressed. Also check selector lever can be shifted from "P" position only when brake pedal is depressed.
3. Move the selector lever and check for excessive effort, sticking, noise or rattle.
4. Check the selector lever stops at each position with the feel of engagement when it is moved through all the positions. Check whether or not the actual position the selector lever is in matches the position shown by the shift position indicator and the transmission body.
5. The method of operating the lever to individual positions correctly should be as shown in the figure.
6. When selector button is pressed in "P", "R", or "N" position without applying forward/backward force to selector lever, check button operation for sticking.
7. Check the back-up lamps illuminate only when lever is placed in the "R" position. Check the back-up lamps does not illuminate when selector lever is pushed against "R" position in the "P" or "N" position.
8. Check the engine can only be started with the selector lever in the "P" and "N" positions. (With selector lever in the "P" position, engine can be started even when selector lever is moved forward and backward.)
9. Check transmission is locked completely in "P" position.
10. When selector lever is set to manual shift gate, check manual mode is displayed on combination meter. Shift selector lever to "+" and "-" sides, and check set shift position changes. (Only while a vehicle is operating.)

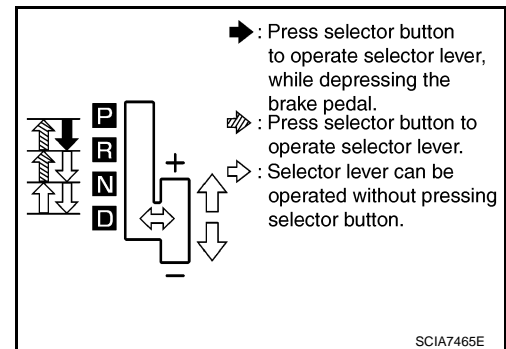

# A/T SHIFT LOCK SYSTEM

< SERVICE INFORMATION >

## A/T SHIFT LOCK SYSTEM

### Description

INFOID:000000001327387

- The mechanical key interlock mechanism also operates as a shift lock:  
With the ignition switch turned to ON, the selector lever cannot be shifted from "P" position to any other position unless the brake pedal is depressed.  
With the key removed, the selector lever cannot be shifted from "P" position to any other position.  
The key cannot be removed unless the selector lever is placed in "P" position.
- The shift lock and key interlock mechanisms are controlled by the ON-OFF operation of the shift lock solenoid and by the operation of the rotator and slider located inside the key cylinder.

### Shift Lock System Electrical Parts Location

INFOID:000000001327388

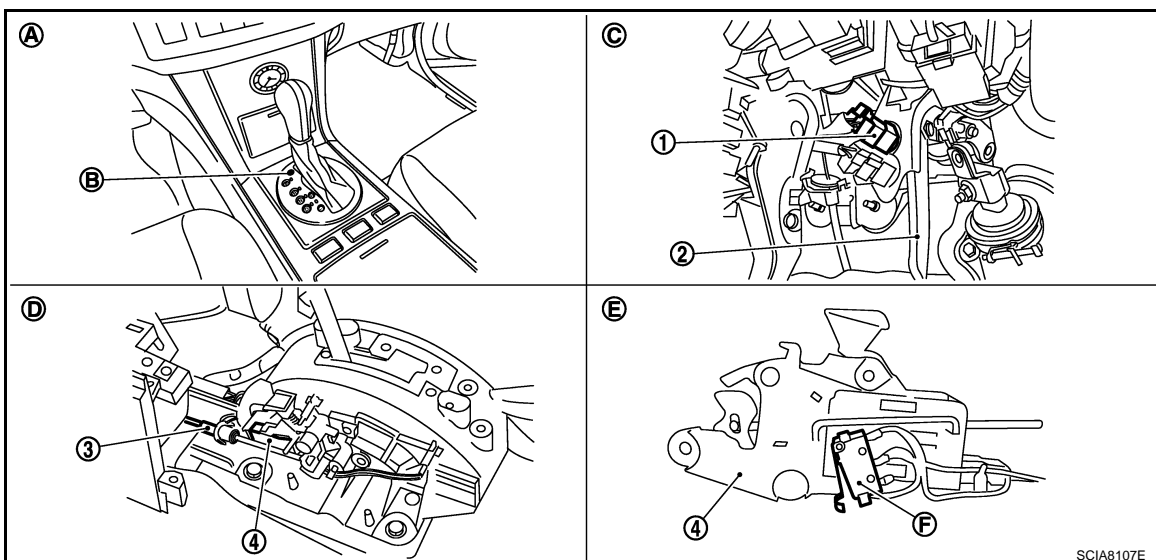

- |                            |                                      |                         |
|----------------------------|--------------------------------------|-------------------------|
| 1. Stop lamp switch        | 2. Brake pedal                       | 3. Key interlock cable  |
| 4. Shift lock solenoid     |                                      |                         |
| A. Center console assembly | B. Shift lock release button         | C. Brake pedal, upper   |
| D. Control device assembly | E. Shift lock solenoid, reverse side | F. Park position switch |



# A/T SHIFT LOCK SYSTEM

< SERVICE INFORMATION >

## Wiring Diagram - AT - SHIFT

INFOID:000000001327389

### AT-SHIFT-01

Ⓚ : WITH INTELLIGENT KEY  
Ⓛ : WITHOUT INTELLIGENT KEY

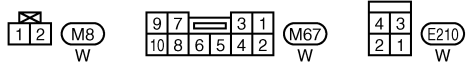
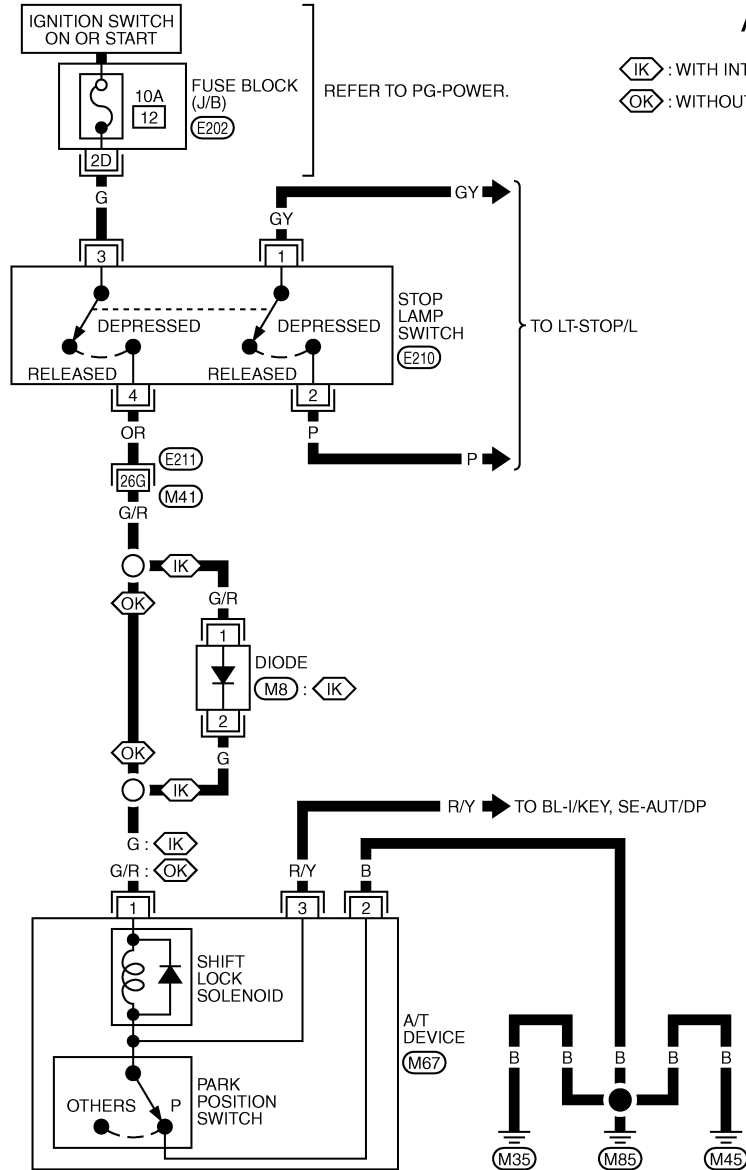

REFER TO THE FOLLOWING.  
 (E211) -SUPER MULTIPLE JUNCTION (SMJ)  
 (E202) -FUSE BLOCK-JUNCTION BOX (J/B)

TCWM0589E

## Diagnosis Procedure

INFOID:000000001327390

### SYMPTOM 1:

- Selector lever cannot be moved from "P" position with key in ON position and brake pedal applied.
- Selector lever can be moved from "P" position with key in ON position and brake pedal released.
- Selector lever can be moved from "P" position when key is removed from key cylinder.

### SYMPTOM 2:

# A/T SHIFT LOCK SYSTEM

## < SERVICE INFORMATION >

- Ignition key cannot be removed when selector lever is set to “P” position.
- Ignition key can be removed when selector lever is set to any position except “P” position.

### 1. CHECK KEY INTERLOCK CABLE

Check the key interlock cable for damage.

#### OK or NG

- OK >> GO TO 2.  
 NG >> Repair or replace key interlock cable. Refer to [AT-212](#).

### 2. CHECK SELECTOR LEVER POSITION

Check the selector lever position for damage. Refer to [AT-207, "Checking of A/T Position"](#)

#### OK or NG

- OK >> GO TO 3.  
 NG >> Adjust A/T position. Refer to [AT-207, "Adjustment of A/T Position"](#).

### 3. CHECK SHIFT LOCK SOLENOID AND PARK POSITION SWITCH

1. Connect A/T device harness connector.
2. Turn ignition switch ON.
3. Selector lever is set in “P” position.
4. Check operation.

Condition	Brake pedal	Operation
When ignition switch is turned to ON and selector lever is set in “P” position.	Depressed	Yes
	Released	No

#### OK or NG

- OK >> **INSPECTION END**  
 NG >> GO TO 4.

### 4. CHECK POWER SOURCE

1. Turn ignition switch ON.
2. Check the voltage between A/T device harness connector M67 terminal 1 and ground. Refer to [AT-209, "Wiring Diagram - AT - SHIFT"](#).

Condition	Brake pedal	Data (Approx.)
When ignition switch is turned to ON.	Depressed	Battery voltage
	Released	0 V

#### OK or NG

- OK >> GO TO 7.  
 NG >> GO TO 5.

### 5. CHECK STOP LAMP SWITCH

1. Turn ignition switch OFF.
2. Disconnect stop lamp switch harness connector.

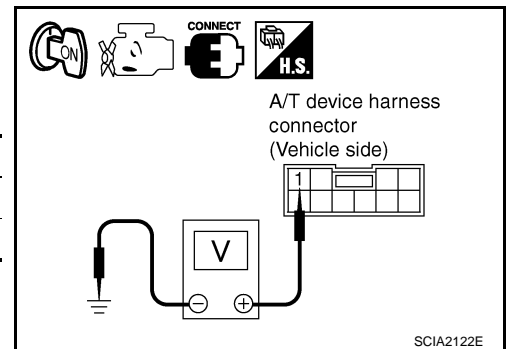

# A/T SHIFT LOCK SYSTEM

## < SERVICE INFORMATION >

- Check continuity between stop lamp switch harness connector E210 terminals 3 and 4.

Condition	Continuity
When brake pedal is depressed	Yes
When brake pedal is released	No

**Check stop lamp switch after adjusting brake pedal — refer to [BR-5](#).**

### OK or NG

- OK >> GO TO 6.
- NG >> Repair or replace damaged parts.

## 6. DETECT MALFUNCTIONING ITEM

Check the following items. If any items are damaged, repair or replace damaged parts.

- Harness for short or open between ignition switch and stop lamp switch harness connector E210 terminal 3.
- Harness for short or open between stop lamp switch harness connector E210 terminal 4 and A/T device harness connector M67 terminal 1.
- 10 A fuse [No.12, located in the fuse block (J/B)].
- Ignition switch, Refer to [PG-3](#).

### OK or NG

- OK >> **INSPECTION END**
- NG >> Repair or replace damaged parts.

## 7. CHECK GROUND CIRCUIT

- Turn ignition switch OFF.
- Disconnect A/T device harness connector.
- Check continuity between A/T device harness connector M67 terminal 2 and ground.

**Continuity should exist.**

### OK or NG

- OK >> Replace shift lock solenoid and park position switch assembly.
- NG >> Repair open circuit in harness or connectors.

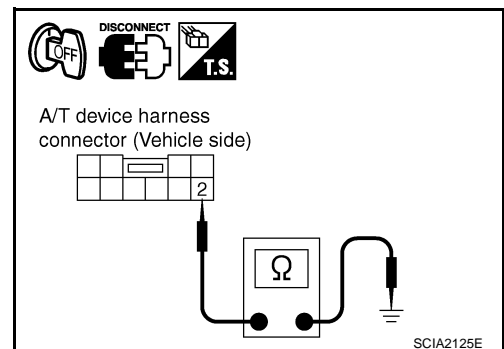
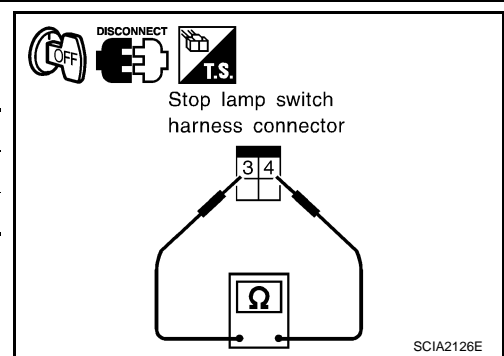

# KEY INTERLOCK CABLE

< SERVICE INFORMATION >

## KEY INTERLOCK CABLE

Component

INFOID:000000001327391

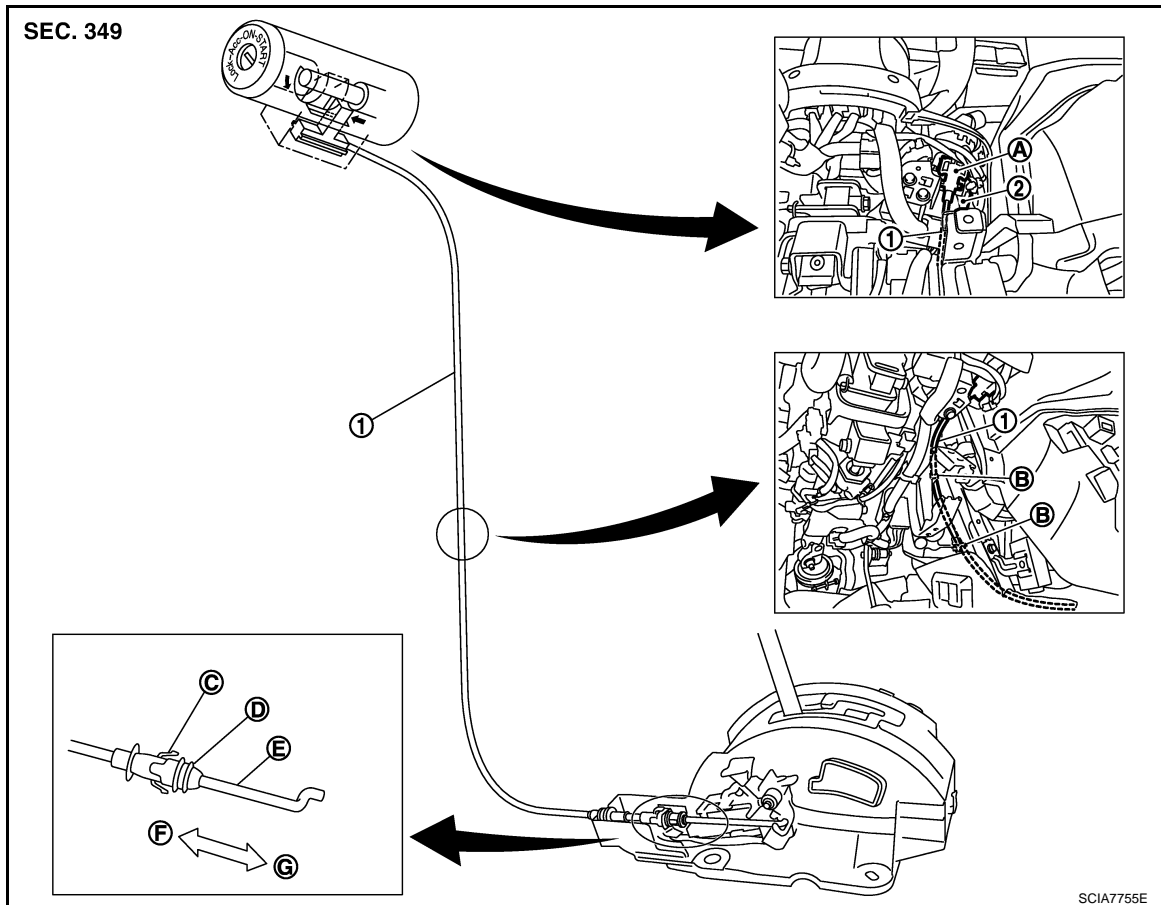

- |                        |                  |           |
|------------------------|------------------|-----------|
| 1. Key interlock cable | 2. Key cylinder  |           |
| A. Holder              | B. Clip          | C. Slider |
| D. Adjuster holder     | E. Interlock rod | F. Unlock |
| G. Lock                |                  |           |

### CAUTION:

- Install key interlock cable in such a way that it will not be damaged by sharp bends, twists or interference with adjacent parts.
- After installing key interlock cable to control device, make sure that casing cap and bracket are firmly secured in their positions. If casing cap be removed with an external load of less than 39.2 N (4.0 kg, 8.8 lb), replace key interlock cable with new one.

### Removal and Installation

INFOID:000000001327392

#### REMOVAL

# KEY INTERLOCK CABLE

## < SERVICE INFORMATION >

1. Unlock slider by squeezing lock tabs on slider from adjuster holder.
2. Remove casing cap from bracket of control device assembly and remove interlock rod from adjuster holder.

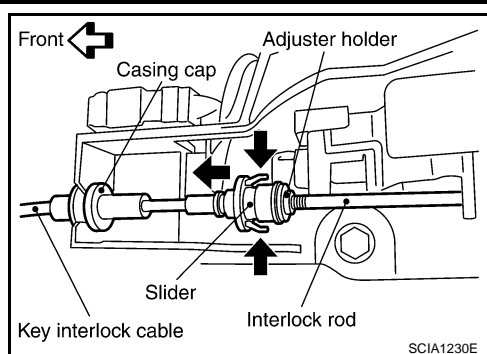

3. Remove holder (A) from key cylinder (1) and remove key interlock cable (2).  
(B) : Clips

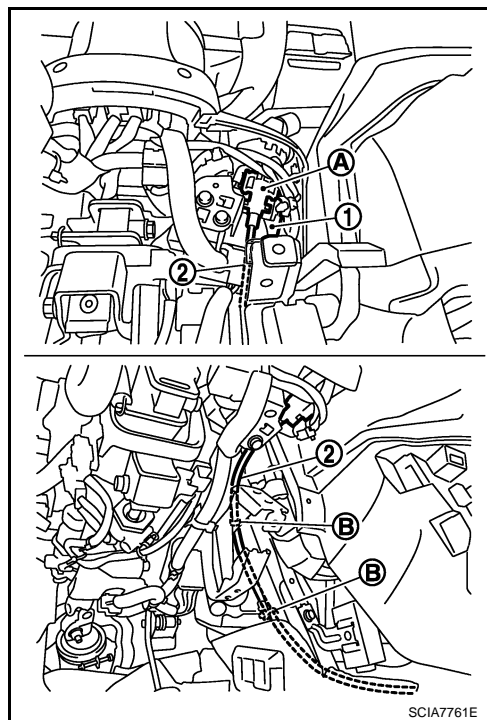

## INSTALLATION

1. Set key interlock cable (2) to key cylinder (1) and install holder (A).
2. Clamp key interlock cable (2) and fix to key interlock cable (2) with clips (B).
3. Turn ignition key to "LOCK" position.
4. Set selector lever to "P" position.

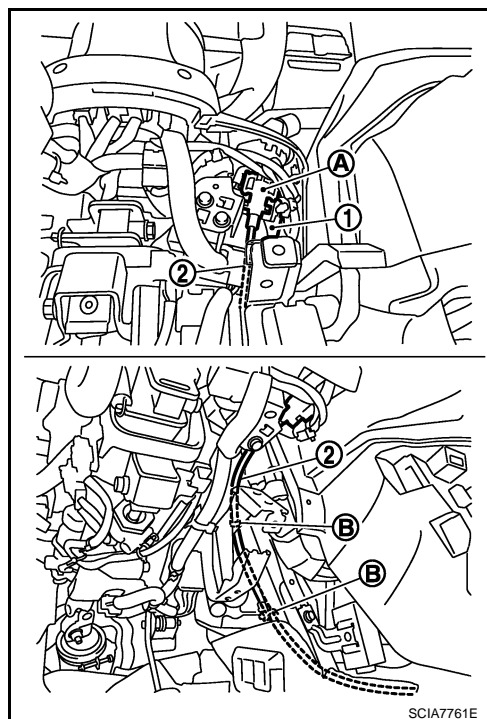

A  
B  
AT  
D  
E  
F  
G  
H  
I  
J  
K  
L  
M  
N  
O  
P

## KEY INTERLOCK CABLE

### < SERVICE INFORMATION >

5. Insert interlock rod into adjuster holder.
6. Install casing cap to bracket.
7. Move slider in order to fix adjuster holder to interlock rod.

**CAUTION:**

**Do not touch adjacent parts of key interlock cable when slider is being held.**

**Insert slider into key interlock rod straightly.**

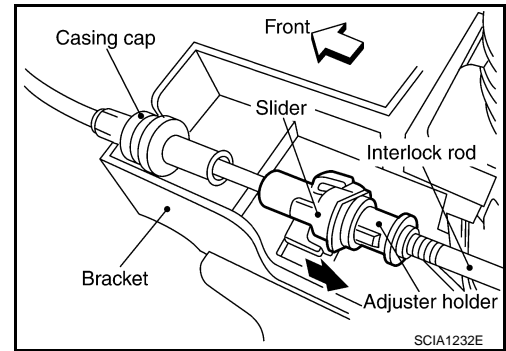

# ON-VEHICLE SERVICE

< SERVICE INFORMATION >

## ON-VEHICLE SERVICE

### Control Valve with TCM and A/T Fluid Temperature Sensor 2

INFOID:000000001327393

#### COMPONENTS

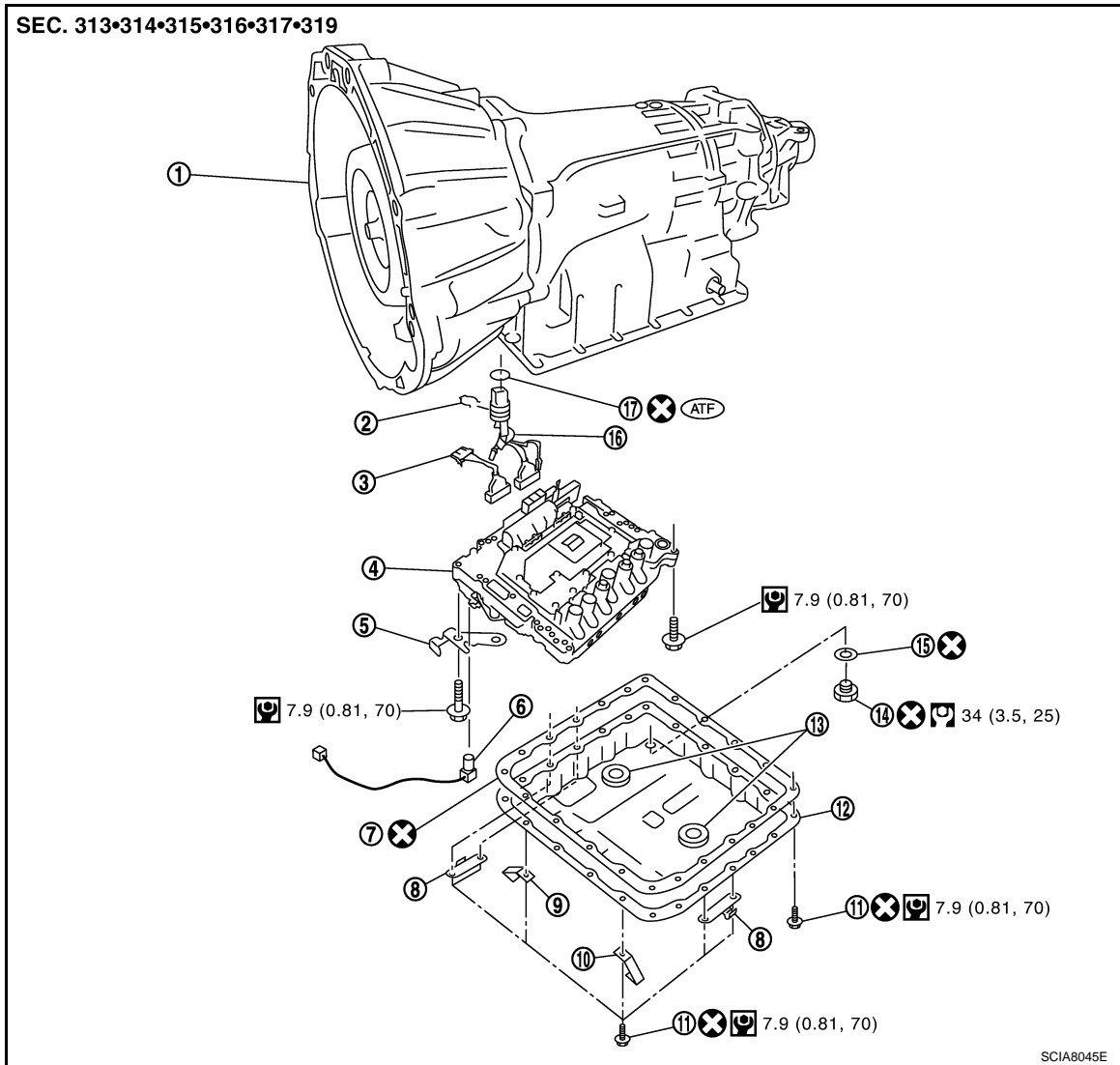

- |                            |                           |                                   |
|----------------------------|---------------------------|-----------------------------------|
| 1. A/T                     | 2. Snap ring              | 3. Sub-harness                    |
| 4. Control valve with TCM  | 5. Bracket                | 6. A/T fluid temperature sensor 2 |
| 7. Oil pan gasket          | 8. Clip                   | 9. Bracket (VK45DE)               |
| 10. Bracket (VK45DE)       | 11. Oil pan mounting bolt | 12. Oil pan                       |
| 13. Magnet                 | 14. Drain plug            | 15. Drain plug gasket             |
| 16. Terminal cord assembly | 17. O-ring                |                                   |

Refer to GI section to make sure icons (symbol marks) in the figure. Refer to [GI-8. "Component"](#).

#### CONTROL VALVE WITH TCM ASSEMBLY REMOVAL AND INSTALLATION

##### Removal

1. Disconnect the battery cable from the negative terminal.
2. Drain ATF through drain plug.
3. Remove front cross bar. Refer to [FSU-6. "Removal and Installation"](#).
4. Disconnect heated oxygen sensor 2 harness connector.
5. Disconnect A/T assembly harness connector.

## ON-VEHICLE SERVICE

### < SERVICE INFORMATION >

6. Remove snap ring from A/T assembly harness connector.

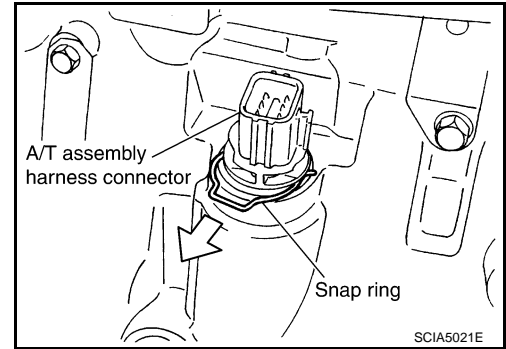

7. Push A/T assembly harness connector.

**CAUTION:**

**Be careful not to damage connector.**

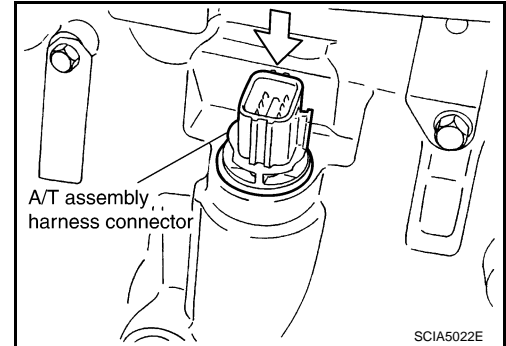

8. Remove bracket (1) (VK45DE), clips (2), oil pan (3) and oil pan gasket.

- ⇐: Vehicle front
- ←: Bolt (22)
- Drain plug (4)

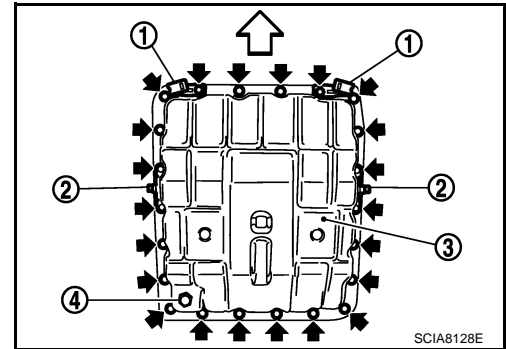

9. Check foreign materials in oil pan to help determine causes of malfunction. If the ATF is very dark, smells burned, or contains foreign particles, the frictional material (clutches, band) may need replacement. A tacky film that will not wipe clean indicates varnish build up. Varnish can cause valves, servo, and clutches to stick and can inhibit pump pressure.

- **If frictional material is detected, perform A/T fluid cooler cleaning. Refer to [AT-13, "A/T Fluid Cooler Cleaning"](#).**

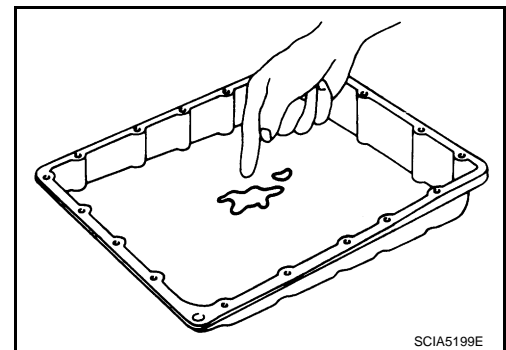

10. Remove magnets from oil pan.

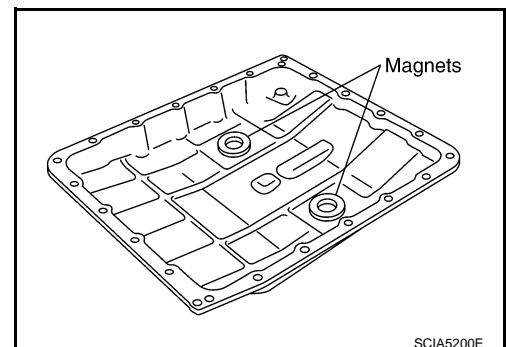



# ON-VEHICLE SERVICE

## < SERVICE INFORMATION >

11. Disconnect A/T fluid temperature sensor 2 connector (1).

**CAUTION:**

**Be careful not to damage connector.**

12. Straighten terminal clips (←) to free terminal cord assembly and A/T fluid temperature sensor 2 harness.

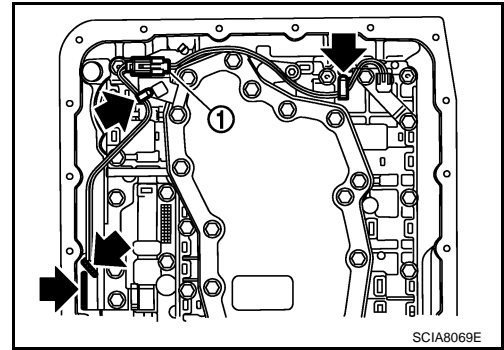

13. Disconnect revolution sensor connector.

**CAUTION:**

**Be careful not to damage connector.**

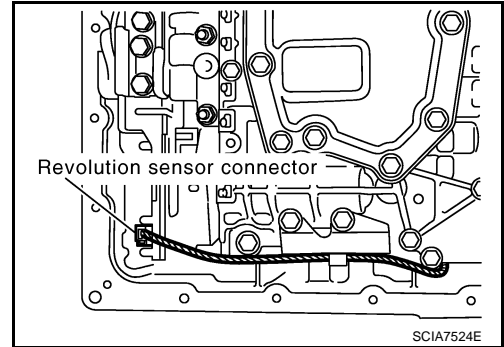

14. Straighten terminal clip to free revolution sensor harness.

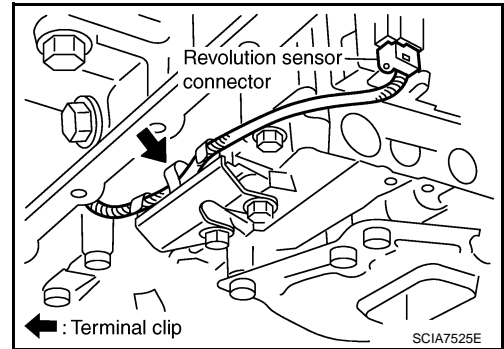

15. Remove bolts A, B and C from control valve with TCM.

- ←: Vehicle front

Bolt symbol	Length mm (in)	Number of bolts
A	42 (1.65)	5
B	55 (2.17)	6
C	40 (1.57)	1

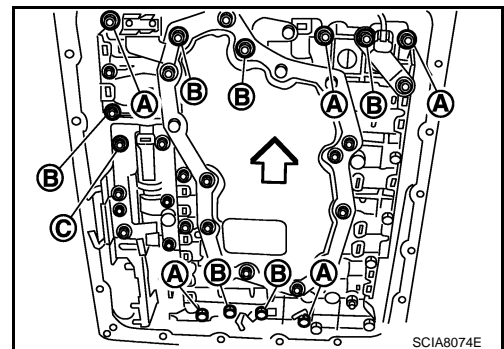

16. Remove control valve with TCM from transmission case.

**CAUTION:**

**When removing, be careful with the manual valve notch and manual plate height. Remove it vertically.**

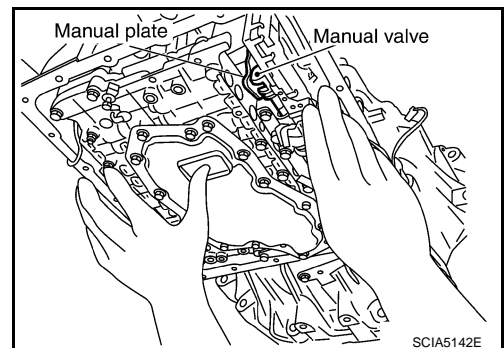

A  
B  
AT  
D  
E  
F  
G  
H  
I  
J  
K  
L  
M  
N  
O  
P

# ON-VEHICLE SERVICE

## < SERVICE INFORMATION >

17. Remove A/T fluid temperature sensor 2 with bracket from control valve with TCM.

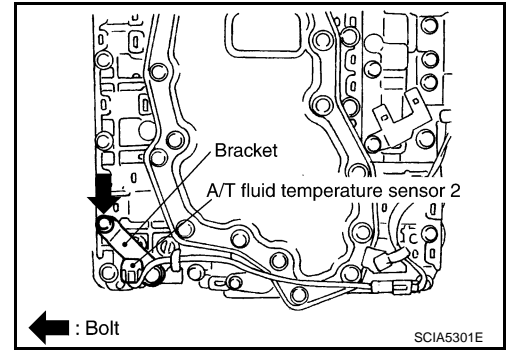

18. Remove bracket from A/T fluid temperature sensor 2.

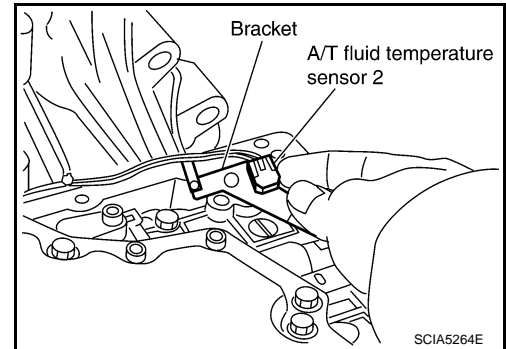

19. Remove O-ring from A/T assembly harness connector.

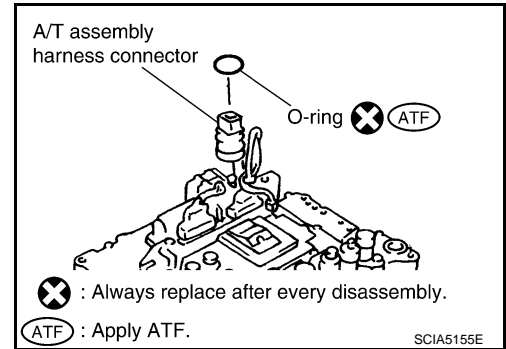

20. Disconnect TCM connectors.

**CAUTION:**

**Be careful not to damage connectors.**

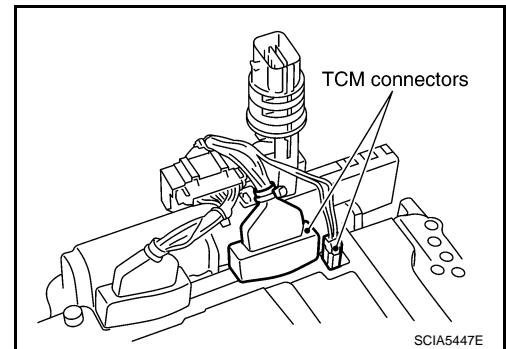

# ON-VEHICLE SERVICE

## < SERVICE INFORMATION >

21. Remove A/T assembly harness connector from control valve with TCM using a flat-bladed screwdriver.

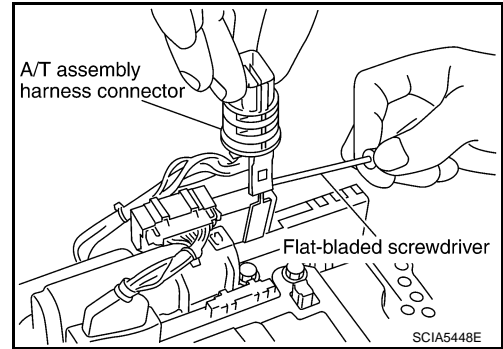

22. Disconnect TCM connector and park/neutral position switch connector.

**CAUTION:**

**Be careful not to damage connectors.**

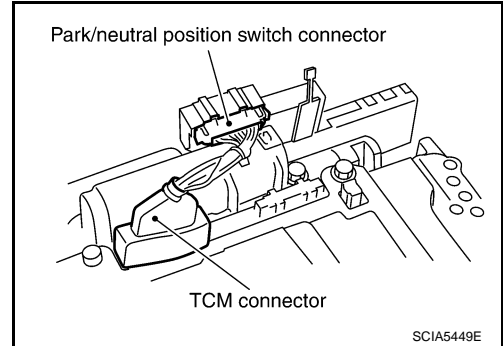

### Installation

**CAUTION:**

**After completing installation, check A/T fluid leakage and A/F fluid level. Refer to [AT-11, "Checking A/T Fluid"](#).**

1. Connect TCM connector and park/neutral position switch connector.

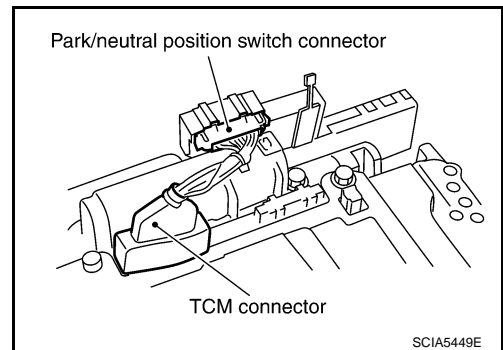

2. Install A/T assembly harness connector from control valve with TCM.

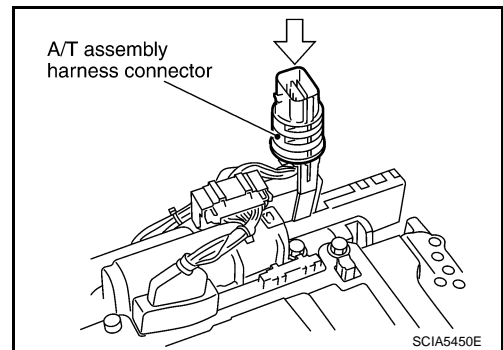

A  
B  
AT  
D  
E  
F  
G  
H  
I  
J  
K  
L  
M  
N  
O  
P

# ON-VEHICLE SERVICE

## < SERVICE INFORMATION >

3. Connect TCM connectors.

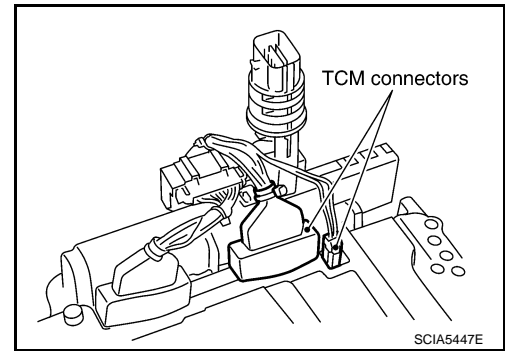

4. Install O-ring in A/T assembly harness connector.

**CAUTION:**

- Do not reuse O-ring.
- Apply ATF to O-ring.

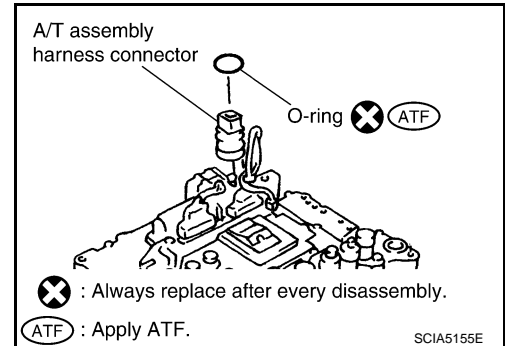

5. Install A/T fluid temperature sensor 2 to bracket.

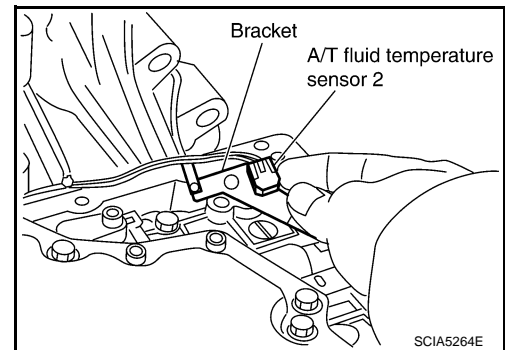

6. Install A/T fluid temperature sensor 2 (with bracket) in control valve with TCM, and then tighten A/T fluid temperature sensor 2 mounting bolt to the specified torque. Refer to "COMPONENTS".

**CAUTION:**

**Adjust bolt hole of bracket to bolt hole of control valve with TCM.**

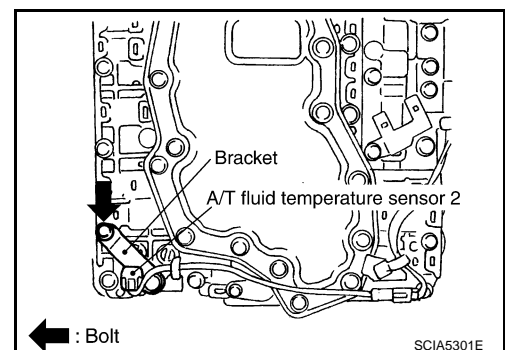

7. Install control valve with TCM in transmission case.

**CAUTION:**

- Make sure that turbine revolution sensor securely installs turbine revolution sensor hole.
- Hang down revolution sensor harness toward outside so as not to disturb installation of control valve with TCM.
- Adjust A/T assembly harness connector of control valve with TCM to terminal hole of transmission case.

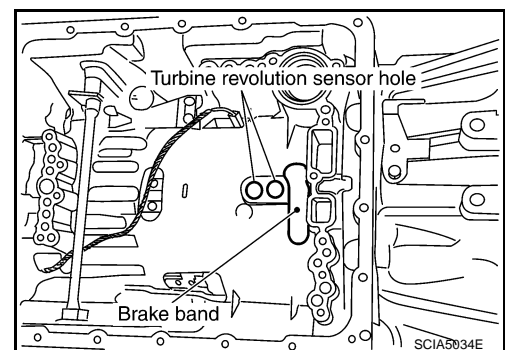

# ON-VEHICLE SERVICE

## < SERVICE INFORMATION >

- Assemble it so that manual valve cutout is engaged with manual plate projection.

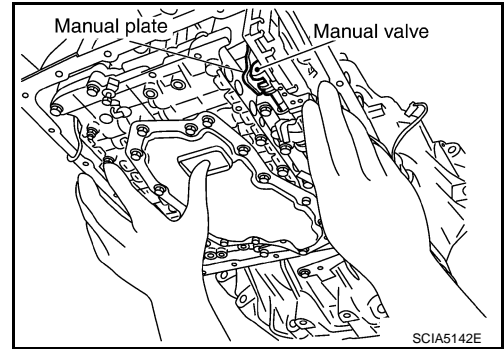

8. Install bolts A, B and C in control valve with TCM.

- ←: Vehicle front

Bolt symbol	Length mm (in)	Number of bolts
A	42 (1.65)	5
B	55 (2.17)	6
C	40 (1.57)	1

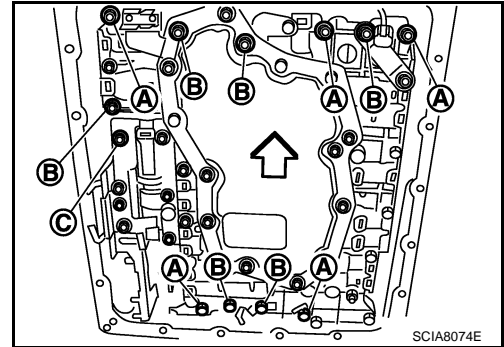

9. Tighten bolt 1, 2 and 3 temporarily to prevent dislocation. After that tighten them in order (1 → 2 → 3), and then tighten other bolts to the specified torque. Refer to "COMPONENTS".

- ←: Vehicle front

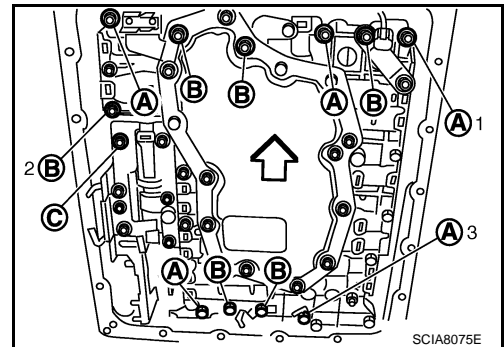

10. Connect A/T fluid temperature sensor 2 connector (1).
11. Securely fasten terminal cord assembly and A/T fluid temperature sensor 2 harness with terminal clips (←).

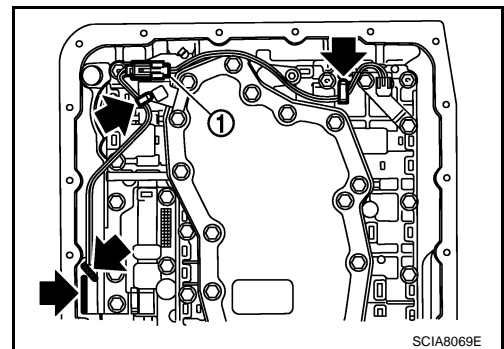

A  
B  
AT  
D  
E  
F  
G  
H  
I  
J  
K  
L  
M  
N  
O  
P

# ON-VEHICLE SERVICE

## < SERVICE INFORMATION >

12. Connect revolution sensor connector.

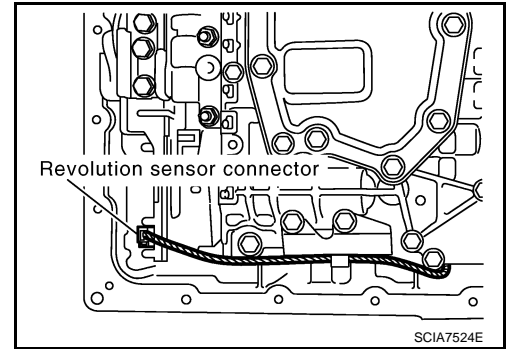

13. Securely fasten revolution sensor harness with terminal clip.

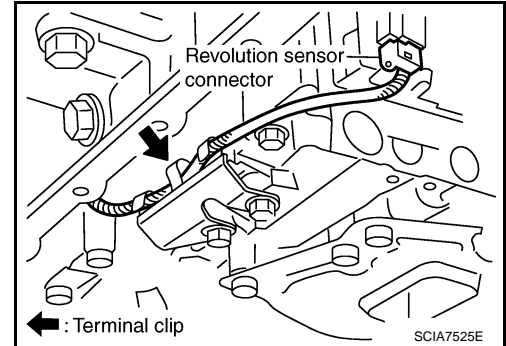

14. Install magnets in oil pan.

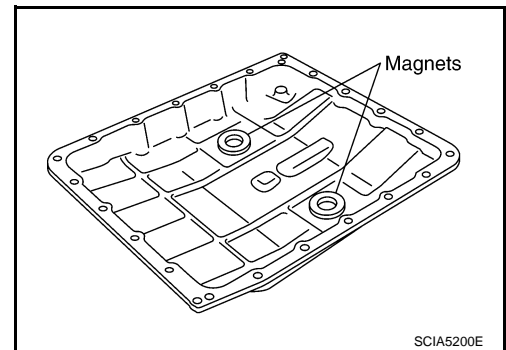

15. Install oil pan to transmission case.

a. Install oil pan gasket to oil pan.

**CAUTION:**

- Do not reuse oil pan gasket.
- Install it in the direction to align hole positions.
- Completely remove all moisture, oil and old gasket, etc. from oil pan gasket mounting surface.

b. Install oil pan (3) (with oil pan gasket), clips (2) and brackets (1) (VK45DE) to transmission case.

- ⇐: Vehicle front
- ←: Bolt (22)

**CAUTION:**

- Install it so that drain plug (4) comes to the position as shown in the figure.
- Be careful not to pinch harnesses.
- Completely remove all moisture, oil and old gasket, etc. from oil pan mounting surface.

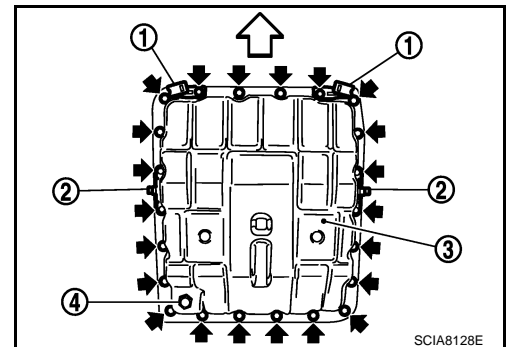

# ON-VEHICLE SERVICE

## < SERVICE INFORMATION >

- c. Tighten oil pan mounting bolts to the specified torque in numerical order shown in the figure after temporarily tightening them. Refer to "COMPONENTS".

**CAUTION:**

**Do not reuse oil pan mounting bolts.**

16. Install drain plug to oil pan, and then tighten drain plug to the specified torque. Refer to "COMPONENTS".

**CAUTION:**

**Do not reuse drain plug gasket.**

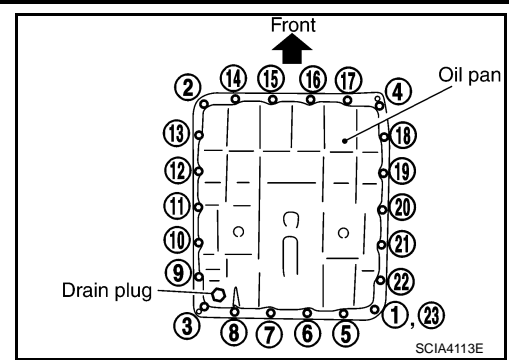

17. Pull up A/T assembly harness connector.

**CAUTION:**

**Be careful not to damage connector.**

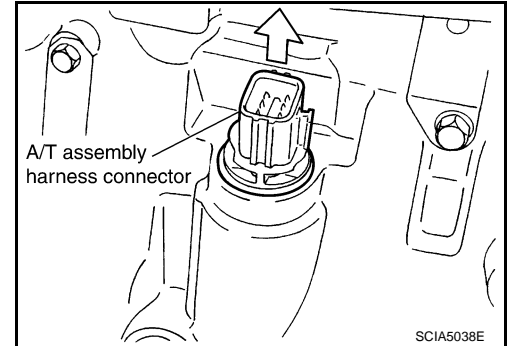

18. Install snap ring to A/T assembly harness connector.

19. Connect A/T assembly harness connector.

20. Connect heated oxygen sensor 2 harness connector.

21. Install front cross bar. Refer to [FSU-6, "Removal and Installation"](#).

22. Pour ATF into A/T assembly. Refer to [AT-11, "Changing A/T Fluid"](#).

23. Connect the battery cable to the negative terminal.

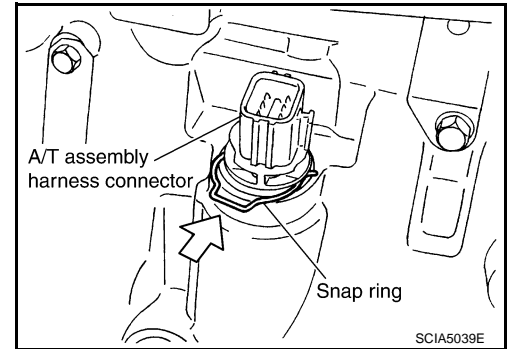

## A/T FLUID TEMPERATURE SENSOR 2 REMOVAL AND INSTALLATION

### Removal

1. Disconnect the battery cable from the negative terminal.
2. Remove front cross bar. Refer to [FSU-6, "Removal and Installation"](#).
3. Disconnect heated oxygen sensor 2 harness connector.
4. Drain ATF through drain plug.
5. Remove bracket (1) (VK45DE), clips (2), oil pan (3) and oil pan gasket.
  - ⇐: Vehicle front
  - ←: Bolt (22)
  - ●: Drain plug (4)

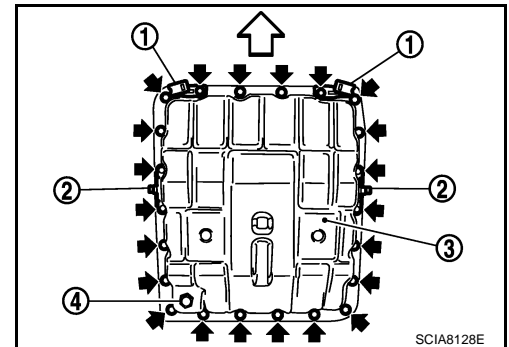

## ON-VEHICLE SERVICE

### < SERVICE INFORMATION >

6. Check foreign materials in oil pan to help determine causes of malfunction. If the ATF is very dark, smells burned, or contains foreign particles, the frictional material (clutches, band) may need replacement. A tacky film that will not wipe clean indicates varnish build up. Varnish can cause valves, servo, and clutches to stick and can inhibit pump pressure.

- If frictional material is detected, perform A/T fluid cooler cleaning. Refer to [AT-13, "A/T Fluid Cooler Cleaning"](#).

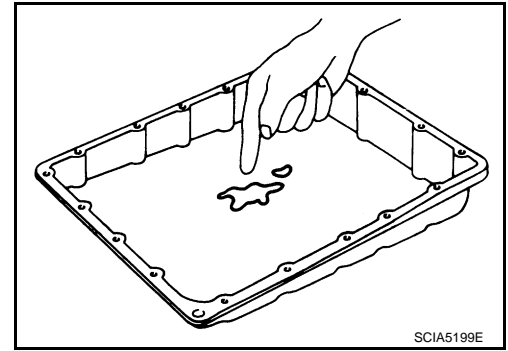

7. Disconnect A/T fluid temperature sensor 2 connector (1).

**CAUTION:**  
Be careful not to damage connector.

8. Straighten terminal clip (←) to free A/T fluid temperature sensor 2 harness.

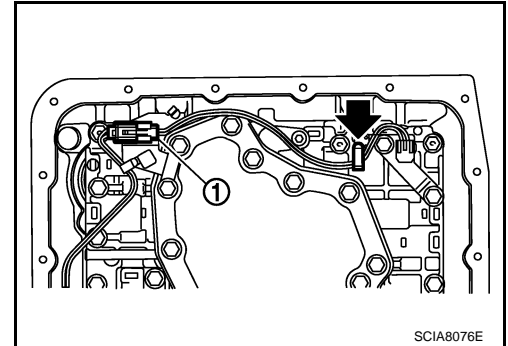

9. Remove A/T fluid temperature sensor 2 with bracket from control valve with TCM.

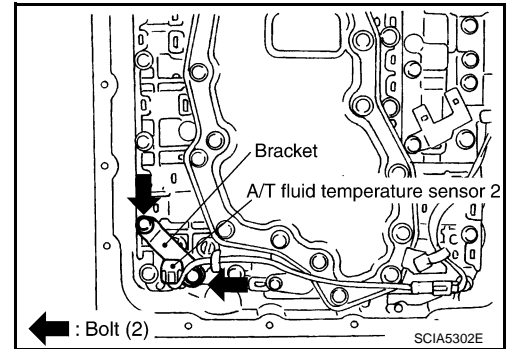

10. Remove bracket from A/T fluid temperature sensor 2.

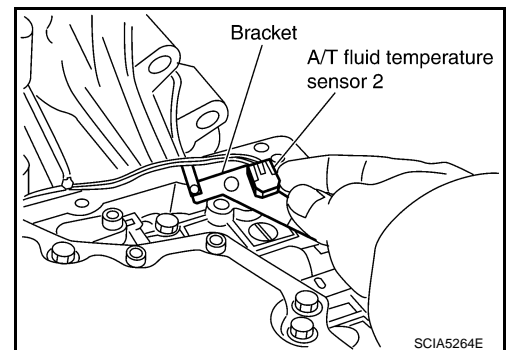

#### Installation

**CAUTION:**

After completing installation, check A/T fluid leakage and A/F fluid level. Refer to [AT-11, "Checking A/T Fluid"](#).



# ON-VEHICLE SERVICE

## < SERVICE INFORMATION >

1. Install A/T fluid temperature sensor 2 to bracket.

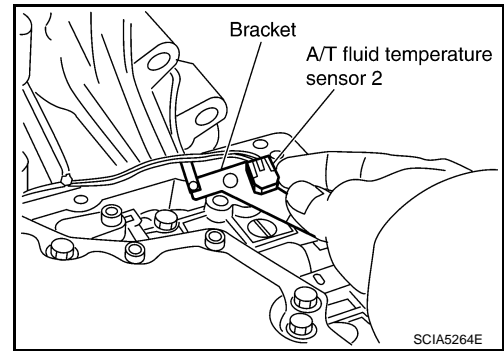

2. Install A/T fluid temperature sensor 2 (with bracket) in control valve with TCM, and then tighten A/T fluid temperature sensor 2 mounting bolt to the specified torque. Refer to "COMPONENTS".

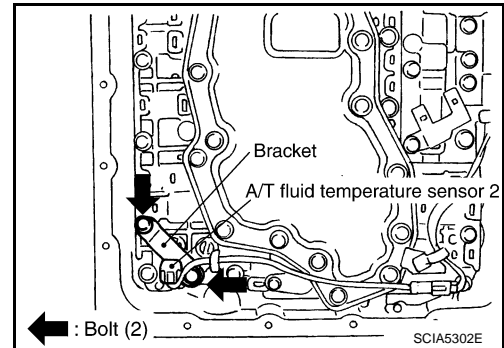

3. Connect A/T fluid temperature sensor 2 connector (1).
4. Securely fasten A/T fluid temperature sensor 2 harness with terminal clip (◀).

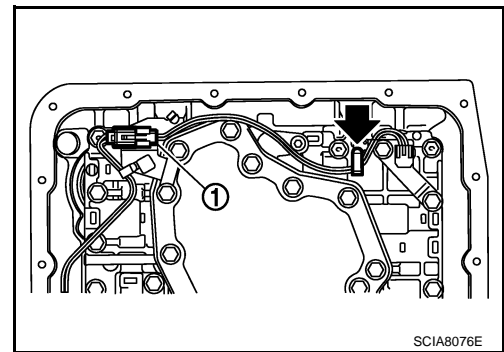

5. Install oil pan to transmission case.
  - a. Install oil pan gasket to oil pan.
 

**CAUTION:**

    - Do not reuse oil pan gasket.
    - Install it in the direction to align hole positions.
    - Completely remove all moisture, oil and old gasket, etc. from oil pan mounting surface.
  - b. Install oil pan (3) (with oil pan gasket), clips (2) and brackets (1) (VK45DE) to transmission case.

- ◀: Vehicle front
- ◀: Bolt (22)

- CAUTION:**
- Install it so that drain plug (4) comes to the position as shown in the figure.
  - Be careful not to pinch harnesses.
  - Completely remove all moisture, oil and old gasket, etc. from oil pan mounting surface.

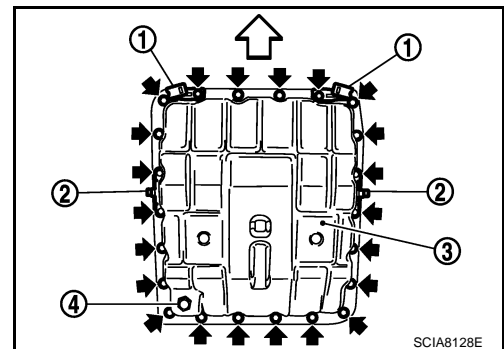

A  
B  
AT  
D  
E  
F  
G  
H  
I  
J  
K  
L  
M  
N  
O  
P

# ON-VEHICLE SERVICE

## < SERVICE INFORMATION >

- c. Tighten oil pan mounting bolts to the specified torque in numerical order shown in the figure after temporarily tightening them. Refer to "COMPONENTS".

**CAUTION:**

**Do not reuse oil pan mounting bolts.**

6. Install drain plug to oil pan, and then tighten drain plug to the specified torque. Refer to "COMPONENTS".

**CAUTION:**

**Do not reuse drain plug gasket.**

7. Connect heated oxygen sensor 2 harness connector.  
 8. Install front cross bar. Refer to [FSU-6, "Removal and Installation"](#).  
 9. Pour ATF into A/T assembly. Refer to [AT-11, "Changing A/T Fluid"](#).  
 10. Connect the battery cable to the negative terminal.

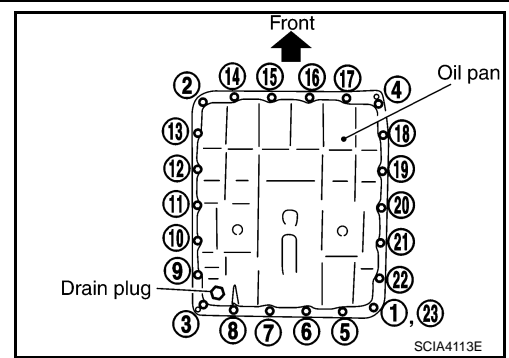

## Parking Component (2WD Models Only)

INFOID:000000001327394

## COMPONENTS

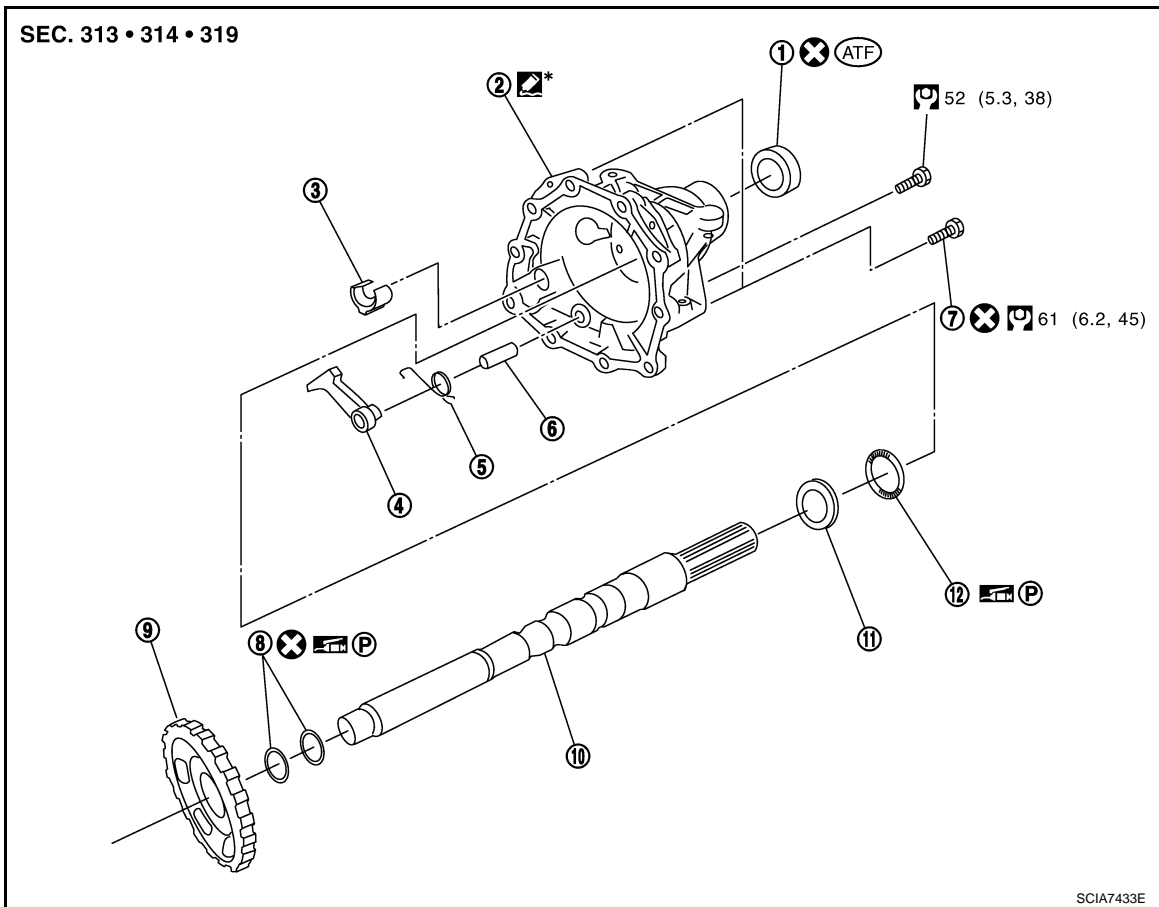

- |                      |                   |                             |
|----------------------|-------------------|-----------------------------|
| 1. Rear oil seal     | 2. Rear extension | 3. Parking actuator support |
| 4. Parking pawl      | 5. Return spring  | 6. Pawl shaft               |
| 7. Self-sealing bolt | 8. Seal ring      | 9. Parking gear             |
| 10. Output shaft     | 11. Bearing race  | 12. Needle bearing          |

Refer to GI section to make sure icons (symbol marks) in the figure. Refer to [GI-8, "Component"](#).

However, refer to the following symbol for others.

 : Apply Genuine Anaerobic Liquid Gasket or equivalent. Refer to [GI-44, "Recommended Chemical Product and Sealant"](#).

## REMOVAL

# ON-VEHICLE SERVICE

## < SERVICE INFORMATION >

1. Drain ATF through drain plug.
2. Remove exhaust front tube and center muffler with power tool. Refer to [EX-3, "Component"](#).
3. Remove rear propeller shaft. Refer to [PR-9, "Removal and Installation"](#).
4. Remove control rod. Refer to [AT-206, "Control Rod Removal and Installation"](#).
5. Support A/T assembly with a transmission jack.  
**CAUTION:**  
**When setting transmission jack, be careful not to allow it to collide against the drain plug.**
6. Remove rear engine mounting member with power tool. Refer to [AT-241, "Removal and Installation \(2WD Models\)"](#).
7. Remove engine mounting insulator (rear). Refer to [AT-241, "Removal and Installation \(2WD Models\)"](#).
8. Remove tightening bolts for rear extension assembly and transmission case.

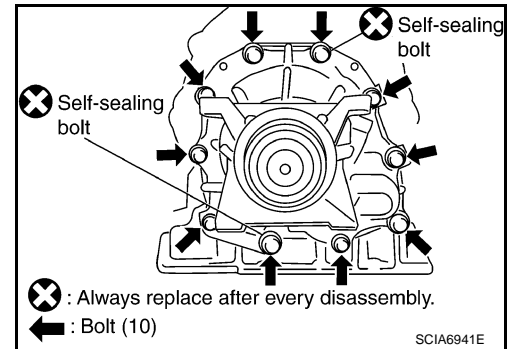

9. Tap rear extension assembly with soft hammer.

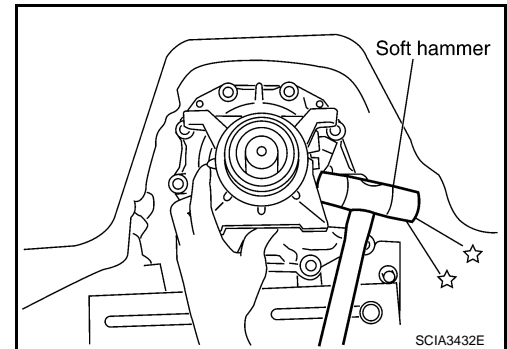

10. Remove rear extension assembly from transmission case. (With needle bearing.)

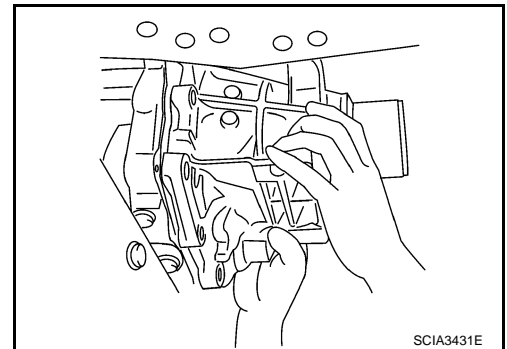

11. Remove bearing race from output shaft.

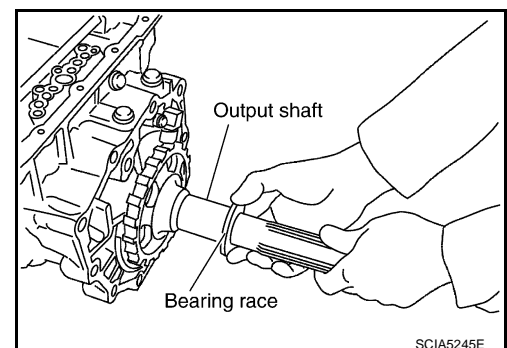

A

B

AT

D

E

F

G

H

I

J

K

L

M

N

O

P

# ON-VEHICLE SERVICE

## < SERVICE INFORMATION >

12. Remove output shaft from transmission case by rotating left/right.

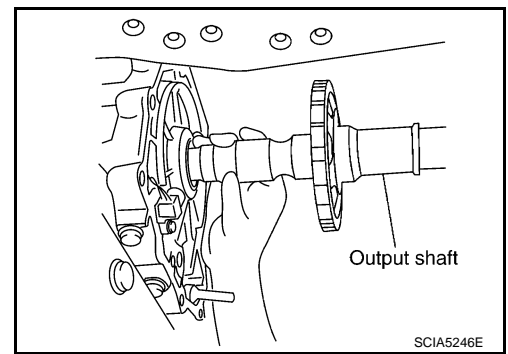

13. Remove parking gear from output shaft.

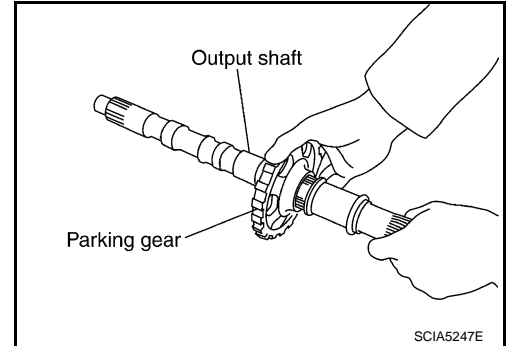

14. Remove seal rings from output shaft.

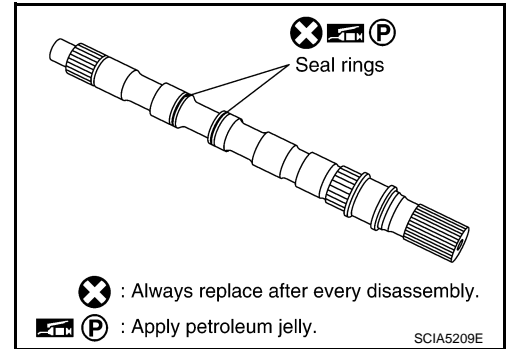

15. Remove needle bearing from rear extension.

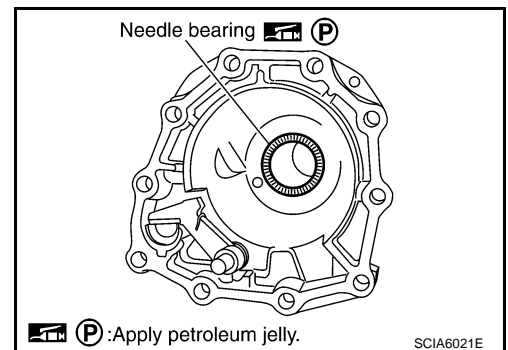

16. Remove parking actuator support from rear extension.

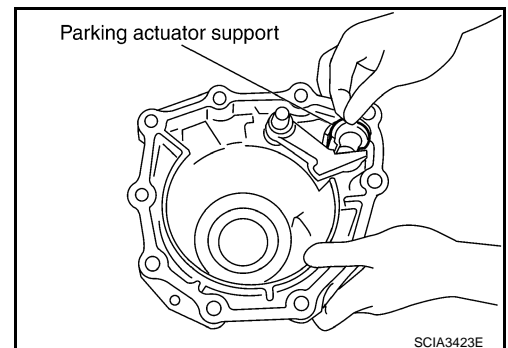

# ON-VEHICLE SERVICE

## < SERVICE INFORMATION >

17. Remove parking pawl (with return spring) and pawl shaft from rear extension.

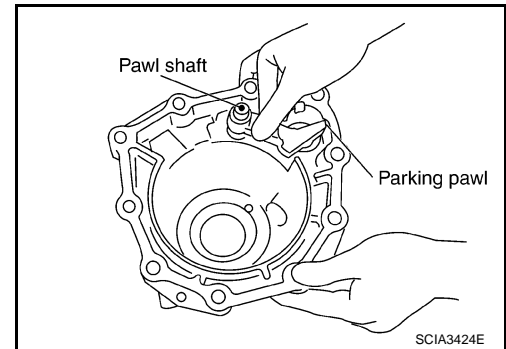

18. Remove return spring from parking pawl.

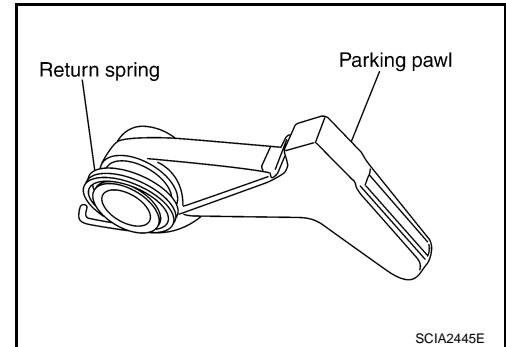

19. Remove rear oil seal from rear extension.  
**CAUTION:**  
**Be careful not to scratch rear extension.**

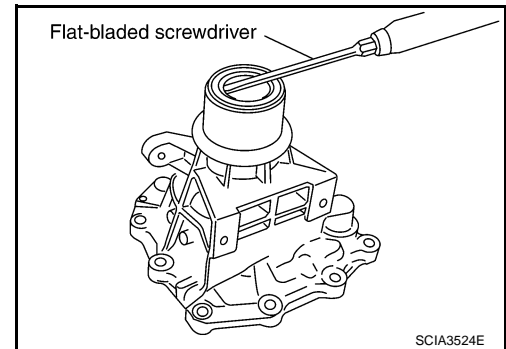

## INSPECTION

- If the contact surface on parking actuator support, parking pawl, etc. has excessive wear, abrasion, bend, or any other damage, replace the components.

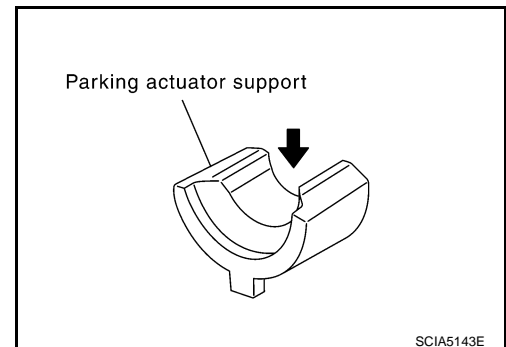

A  
B  
AT  
D  
E  
F  
G  
H  
I  
J  
K  
L  
M  
N  
O  
P

# ON-VEHICLE SERVICE

## < SERVICE INFORMATION >

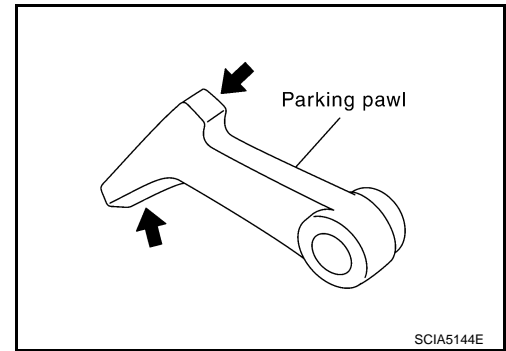

### INSTALLATION

#### **CAUTION:**

After completing installation, check A/T position, A/T fluid leakage and A/F fluid level. Refer to [AT-207](#), "[Checking of A/T Position](#)", [AT-11](#), "[Checking A/T Fluid](#)".

1. As shown in the figure, use a drift to drive rear oil seal into the rear extension until it is flush.

#### **CAUTION:**

- Do not reuse rear oil seal.
- Apply ATF to rear oil seal.

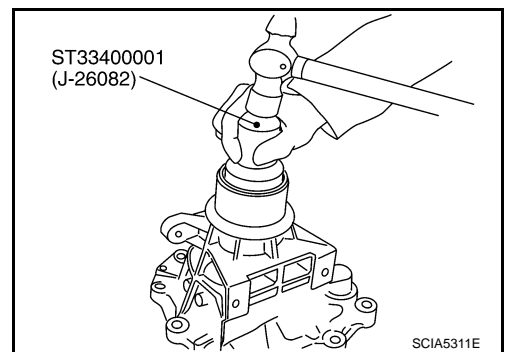

2. Install return spring to parking pawl.

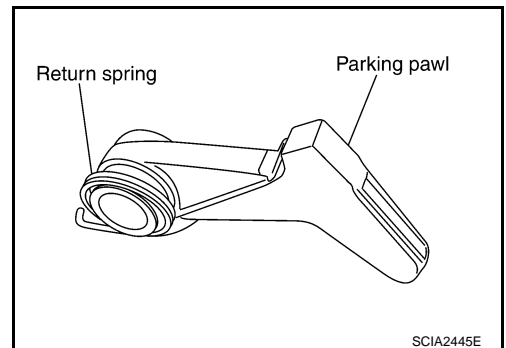

3. Install parking pawl (with return spring) and pawl shaft to rear extension.

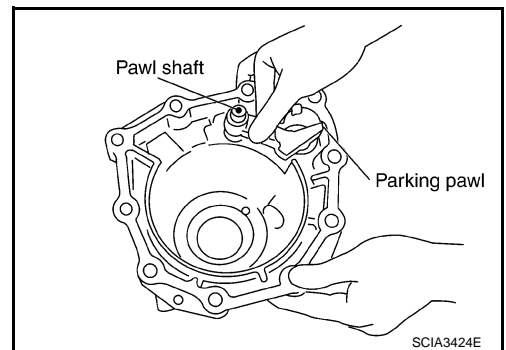

# ON-VEHICLE SERVICE

## < SERVICE INFORMATION >

4. Install parking actuator support to rear extension.

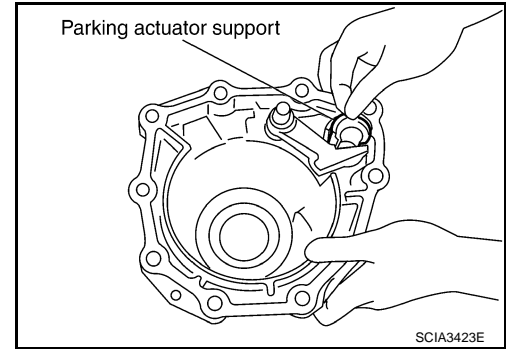

5. Install needle bearing to rear extension.

**CAUTION:**

- Take care with the direction of needle bearing. Refer to [AT-264, "Location of Adjusting Shims, Needle Bearings, Thrust Washers and Snap Rings"](#).
- Apply petroleum jelly to needle bearing.

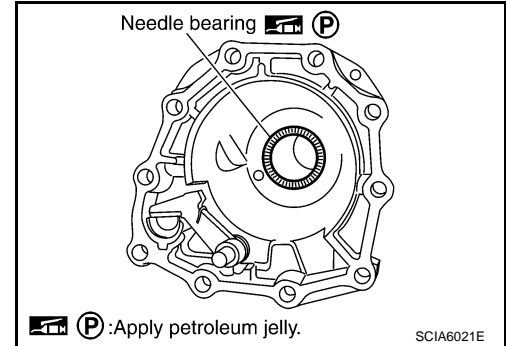

6. Install seal rings in output shaft.

**CAUTION:**

- Do not reuse seal rings.
- Apply petroleum jelly to seal rings.

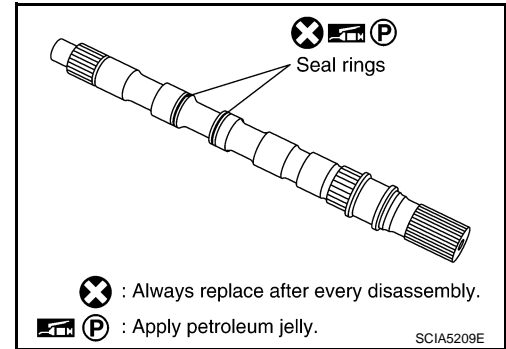

7. Install parking gear to output shaft

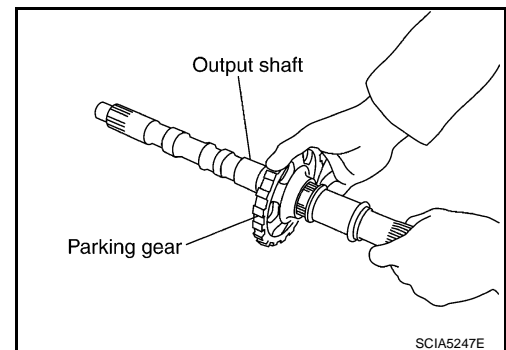

8. Install output shaft to transmission case.

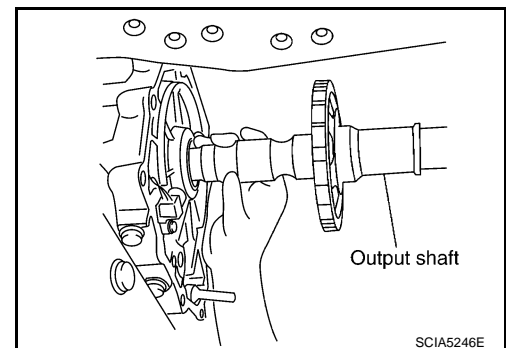

A  
B  
AT  
D  
E  
F  
G  
H  
I  
J  
K  
L  
M  
N  
O  
P

# ON-VEHICLE SERVICE

## < SERVICE INFORMATION >

9. Install bearing race to output shaft.

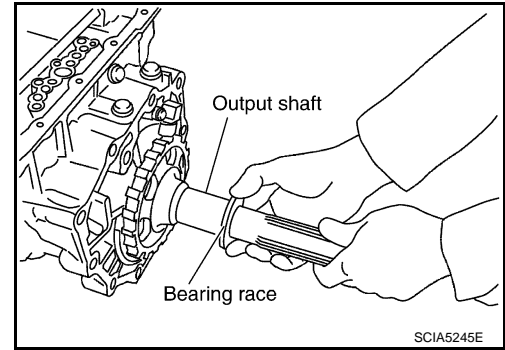

10. Apply recommended sealant (Genuine Anaerobic Liquid Gasket or equivalent. Refer to [GI-44, "Recommended Chemical Product and Sealant"](#).) to rear extension assembly as shown in the figure.

**CAUTION:**

Completely remove all moisture, oil and old sealant, etc. from the transmission case and rear extension assembly mounting surfaces.

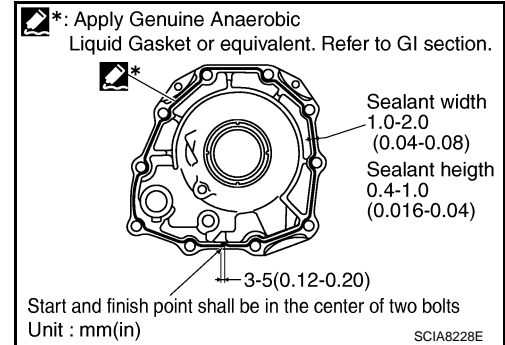

11. Install rear extension assembly to transmission case. (With needle bearing.)

**CAUTION:**

Insert the tip of parking rod between the parking pawl and the parking actuator support when assembling the rear extension assembly.

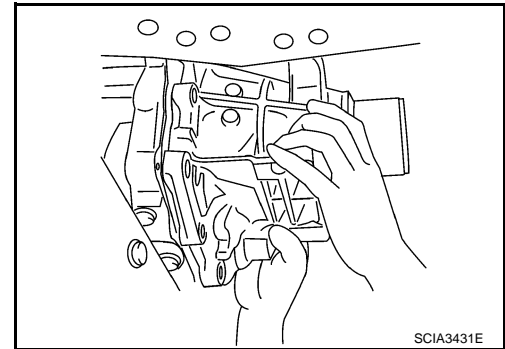

12. Tighten rear extension assembly mounting bolts to specified torque. Refer to "COMPONENTS".

**CAUTION:**

Do not reuse self-sealing bolts.

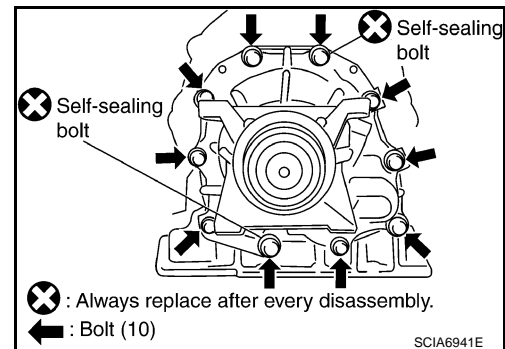

13. Install engine mounting insulator (rear). Refer to [AT-241, "Removal and Installation \(2WD Models\)"](#).

14. Install rear engine mounting member. Refer to [AT-241, "Removal and Installation \(2WD Models\)"](#).

15. Install control rod. Refer to [AT-206, "Control Rod Removal and Installation"](#).

16. Install rear propeller shaft. Refer to [PR-9, "Removal and Installation"](#).

17. Install exhaust front tube and center muffler. Refer to [EX-3, "Component"](#).

18. Install drain plug in oil pan, and then tighten drain plug to the specified torque. Refer to [AT-215, "Control Valve with TCM and A/T Fluid Temperature Sensor 2"](#).

**CAUTION:**

Do not reuse drain plug gasket.

19. Pour ATF into A/T assembly. Refer to [AT-11, "Changing A/T Fluid"](#).



# ON-VEHICLE SERVICE

## < SERVICE INFORMATION >

### Rear Oil Seal

INFOID:000000001327395

#### REMOVAL

1. Remove center muffler with power tool. Refer to [EX-3. "Component"](#).
2. Remove rear propeller shaft. Refer to [PR-9. "Removal and Installation"](#).
3. Remove front propeller shaft (AWD models). Refer to [PR-4. "Removal and Installation"](#).
4. Remove transfer assembly from A/T assembly (AWD models). Refer to [TF-40. "Removal and Installation"](#).
5. Remove rear oil seal using a flat-bladed screwdriver.

**CAUTION:**

Be careful not to scratch rear extension assembly (2WD models) or adapter case assembly (AWD models).

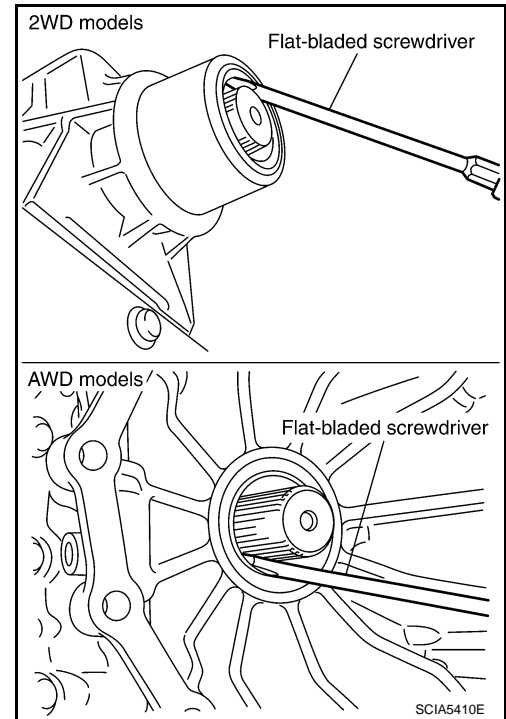

#### INSTALLATION

**CAUTION:**

After completing installation, check A/T fluid leakage and A/T fluid level. Refer to [AT-11. "Checking A/T Fluid"](#).

1. As shown in the figure, use the drift to drive rear oil seal into rear extension assembly (2WD models) or adapter case assembly (AWD models) until it is flush.

**CAUTION:**

- Do not reuse rear oil seal.
- Apply ATF to rear oil seal.

2. Install transfer assembly to A/T assembly (AWD models). Refer to [TF-40. "Removal and Installation"](#).
3. Install front propeller shaft (AWD models). Refer to [PR-4. "Removal and Installation"](#).
4. Install rear propeller shaft. Refer to [PR-9. "Removal and Installation"](#).
5. Install center muffler. Refer to [EX-3. "Component"](#).

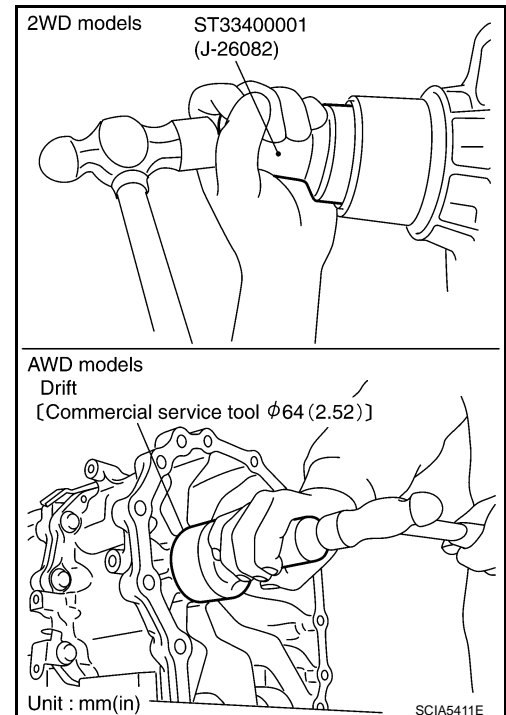

### Revolution Sensor Component (2WD Models Only)

INFOID:000000001327396

#### COMPONENTS

# ON-VEHICLE SERVICE

< SERVICE INFORMATION >

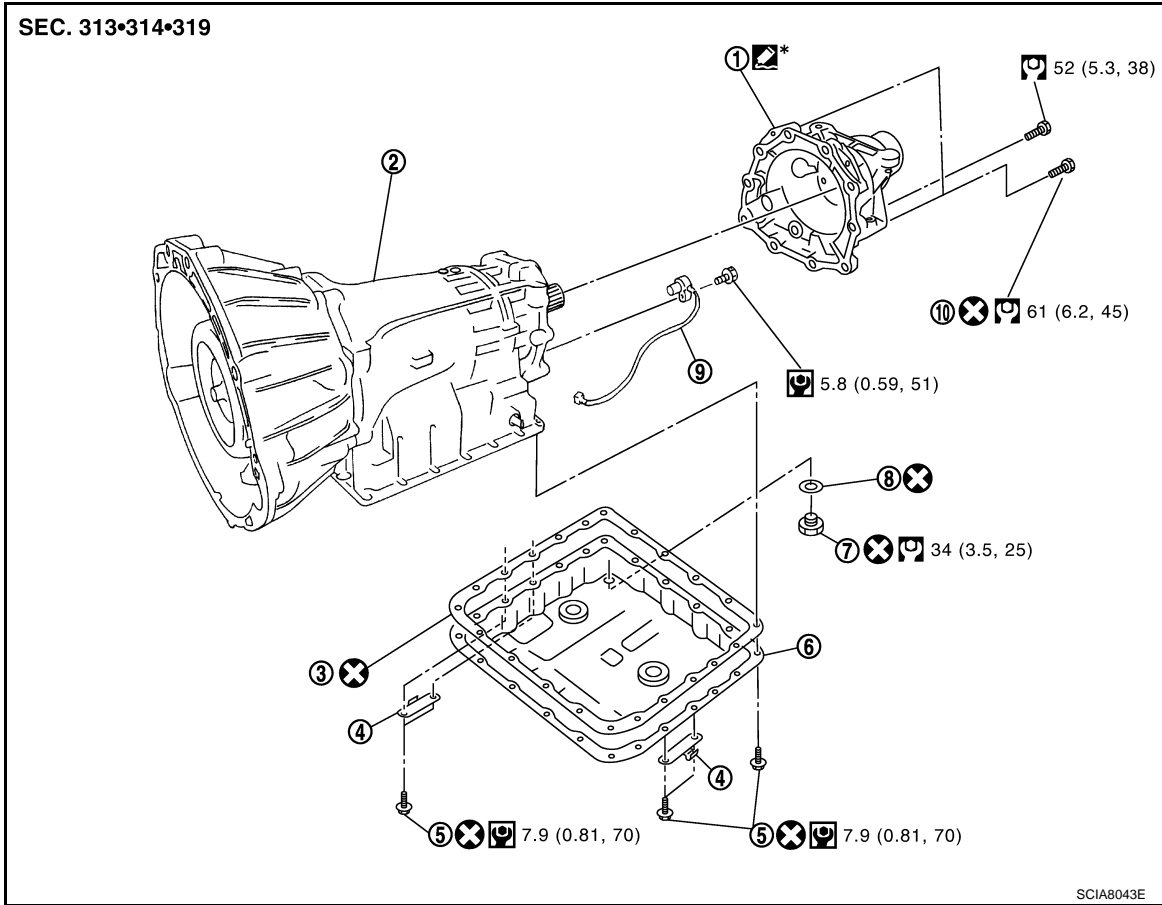



- |                       |                          |                      |
|-----------------------|--------------------------|----------------------|
| 1. Rear extension     | 2. A/T                   | 3. Oil pan gasket    |
| 4. Clip               | 5. Oil pan mounting bolt | 6. Oil pan           |
| 7. Drain plug         | 8. Drain plug gasket     | 9. Revolution sensor |
| 10. Self-sealing bolt |                          |                      |

Refer to GI section to make sure icons (symbol marks) in the figure. Refer to [GI-8, "Component"](#).

However, refer to the following symbol for others.

 : Apply Genuine Anaerobic Liquid Gasket or equivalent. Refer to [GI-44, "Recommended Chemical Product and Sealant"](#)

## REMOVAL

1. Disconnect the battery cable from the negative terminal.
2. Drain ATF through drain plug.
3. Remove front cross bar. Refer to [FSU-6, "Removal and Installation"](#).
4. Remove exhaust front tube and center muffler with power tool. Refer to [EX-3, "Component"](#).
5. Remove rear propeller shaft. Refer to [PR-9, "Removal and Installation"](#).
6. Remove control rod. Refer to [AT-206, "Control Rod Removal and Installation"](#).
7. Remove clips (1), oil pan (2) and oil pan gasket.
  - : Vehicle front
  - : Bolt (22)
  - : Drain plug (3)

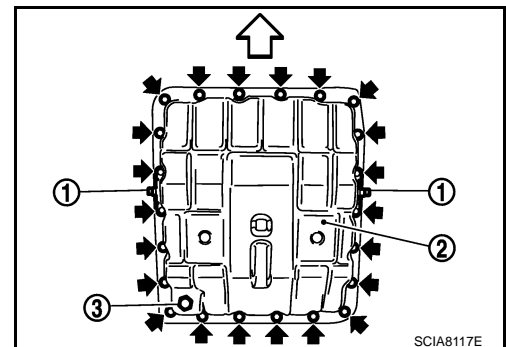

# ON-VEHICLE SERVICE

## < SERVICE INFORMATION >

8. Check foreign materials in oil pan to help determine causes of malfunction. If the ATF is very dark, smells burned, or contains foreign particles, the frictional material (clutches, band) may need replacement. A tacky film that will not wipe clean indicates varnish build up. Varnish can cause valves, servo, and clutches to stick and can inhibit pump pressure.

- If frictional material is detected, perform A/T fluid cooler cleaning. Refer to [AT-13, "A/T Fluid Cooler Cleaning"](#).

9. Support A/T assembly with a transmission jack.

**CAUTION:**

**When setting transmission jack, place wooden blocks to prevent from damaging control valve with TCM and transmission case.**

10. Remove rear engine mounting member with power tool. Refer to [AT-241, "Removal and Installation \(2WD Models\)"](#).
11. Remove tightening bolts for rear extension assembly and transmission case.

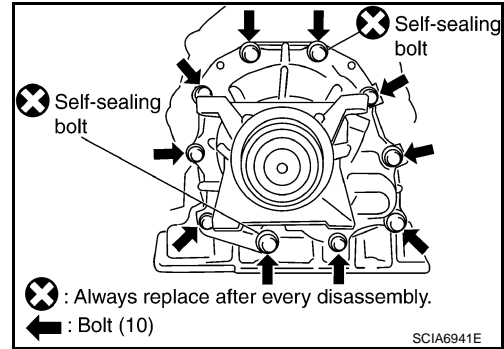
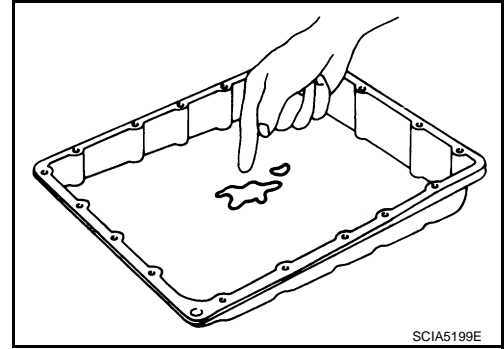

12. Tap rear extension assembly with soft hammer.

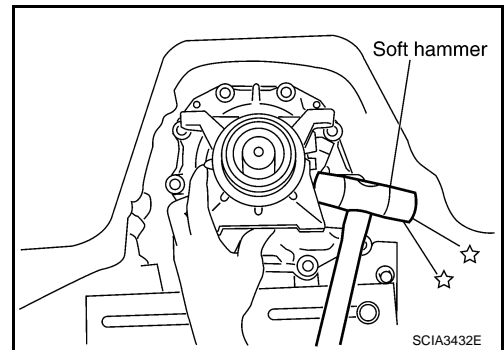

13. Remove rear extension assembly from transmission case. (With needle bearing.)

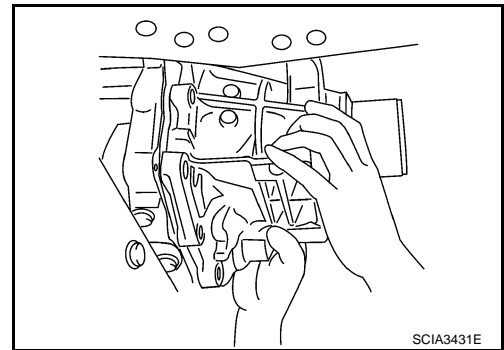

A  
B  
AT  
D  
E  
F  
G  
H  
I  
J  
K  
L  
M  
N  
O  
P

# ON-VEHICLE SERVICE

## < SERVICE INFORMATION >

14. Disconnect revolution sensor connector.

**CAUTION:**

Be careful not to damage connector

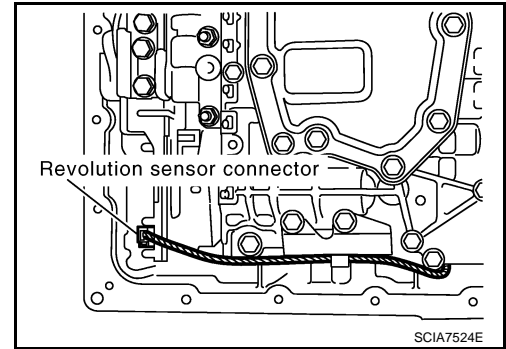

15. Straighten terminal clip to free revolution sensor harness.

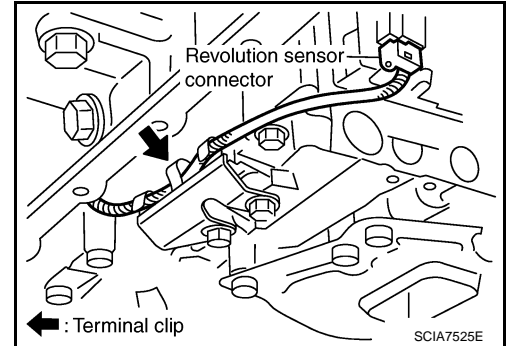

16. Remove revolution sensor from transmission case.

**CAUTION:**

- Do not subject it to impact by dropping or hitting it.
- Do not disassemble.
- Do not allow metal filings, etc. to get on the sensor's front edge magnetic area.
- Do not place in an area affected by magnetism.

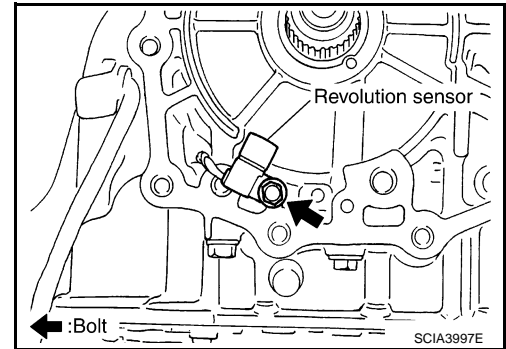

## INSTALLATION

**CAUTION:**

After completing installation, check A/T position, A/T fluid leakage and A/F fluid level. Refer to [AT-207](#), "[Checking of A/T Position](#)", [AT-11](#), "[Checking A/T Fluid](#)".

1. Install revolution sensor in transmission case, and then tighten revolution sensor mounting bolt to the specified torque. Refer to "COMPONENTS".

**CAUTION:**

- Do not subject it to impact by dropping or hitting it.
- Do not disassemble.
- Do not allow metal filings, etc. to get on the sensor's front edge magnetic area.
- Do not place in an area affected by magnetism.

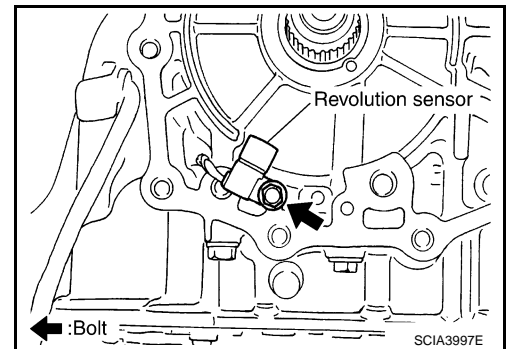

# ON-VEHICLE SERVICE

## < SERVICE INFORMATION >

2. Connect revolution sensor connector.

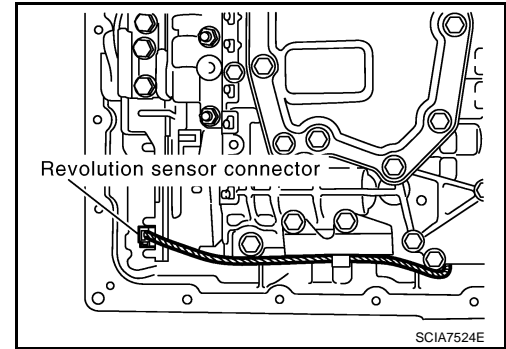

3. Securely fasten revolution sensor harness with clip.

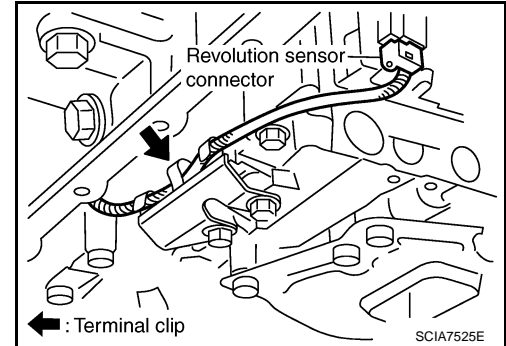

4. Apply recommended sealant (Genuine Anaerobic Liquid Gasket or equivalent. Refer to [GI-44. "Recommended Chemical Product and Sealant"](#).) to rear extension assembly as shown in the figure.

**CAUTION:**

Completely remove all moisture, oil and old sealant, etc. from transmission case and rear extension assembly mounting surfaces.

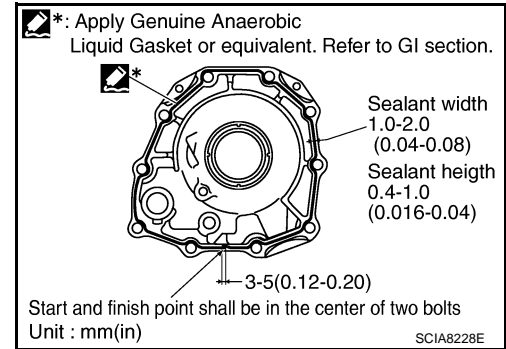

5. Install rear extension assembly to transmission case. (With needle bearing.)

**CAUTION:**

Insert the tip of parking rod between the parking pole and the parking actuator support when assembling the rear extension assembly.

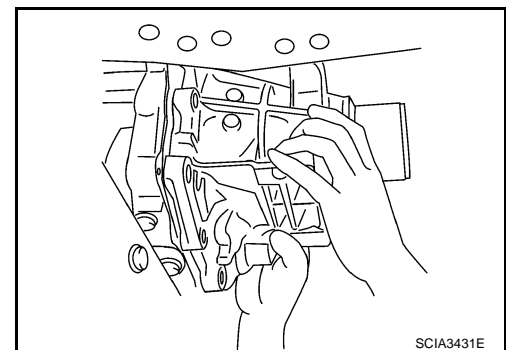

6. Tighten rear extension assembly mounting bolts to specified torque. Refer to "COMPONENTS".

**CAUTION:**

Do not reuse self-sealing bolts.

7. Install rear engine mounting member. Refer to [AT-241. "Removal and Installation \(2WD Models\)"](#).

8. Install oil pan to transmission case.

- a. Install oil pan gasket to oil pan.

**CAUTION:**

- Do not reuse oil pan gasket.
- Install it in the direction to align hole positions.

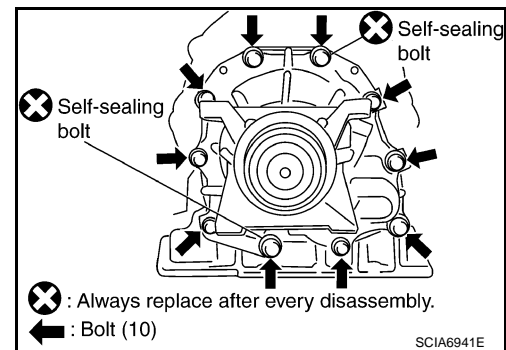

A  
B  
AT  
D  
E  
F  
G  
H  
I  
J  
K  
L  
M  
N  
O  
P

## ON-VEHICLE SERVICE

### < SERVICE INFORMATION >

- **Completely remove all moisture, oil and old gasket, etc. from oil pan mounting surface.**

- b. Install oil pan (2) (with oil pan gasket) and clips (1) to transmission case.

- ⇐: Vehicle front

- ←: Bolt (22)

**CAUTION:**

- **Install it so that drain plug (3) comes to the position as shown in the figure.**
- **Be careful not to pinch harnesses.**
- **Completely remove all moisture, oil and old gasket, etc. from oil pan mounting surface.**

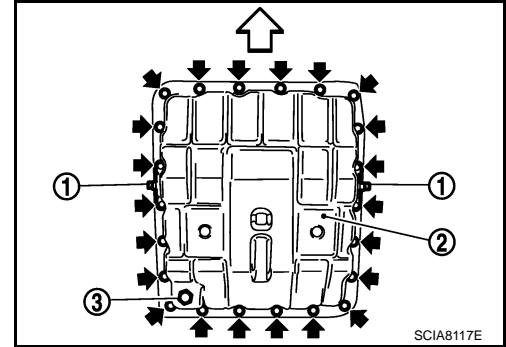

- c. Tighten oil pan mounting bolts to the specified torque in numerical order shown in the figure after temporarily tightening them. Refer to "COMPONENTS".

**CAUTION:**

**Do not reuse oil pan mounting bolts.**

9. Install drain plug to oil pan, and then tighten drain plug to the specified torque. Refer to "COMPONENTS".

**CAUTION:**

**Do not reuse drain plug gasket.**

10. Install control rod. Refer to [AT-206, "Control Rod Removal and Installation"](#).
11. Install rear propeller shaft. Refer to [PR-9, "Removal and Installation"](#).
12. Install exhaust front tube and center muffler. Refer to [EX-3, "Component"](#).
13. Install front cross bar. Refer to [FSU-6, "Removal and Installation"](#).
14. Pour ATF into A/T assembly. Refer to [AT-11, "Changing A/T Fluid"](#).
15. Connect the battery cable to the negative terminal.

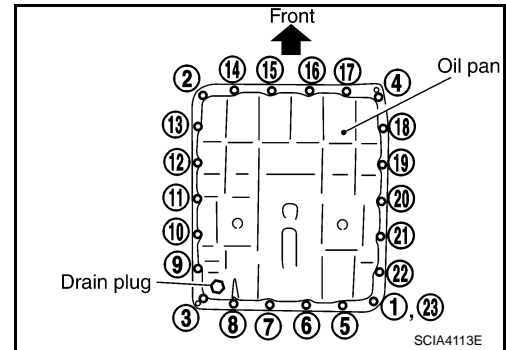

# AIR BREATHER HOSE

< SERVICE INFORMATION >

## AIR BREATHER HOSE

### Removal and Installation

INFOID:000000001327397

#### VQ35DE ENGINE MODEL

Refer to the figure below for air breather hose removal and installation procedure.

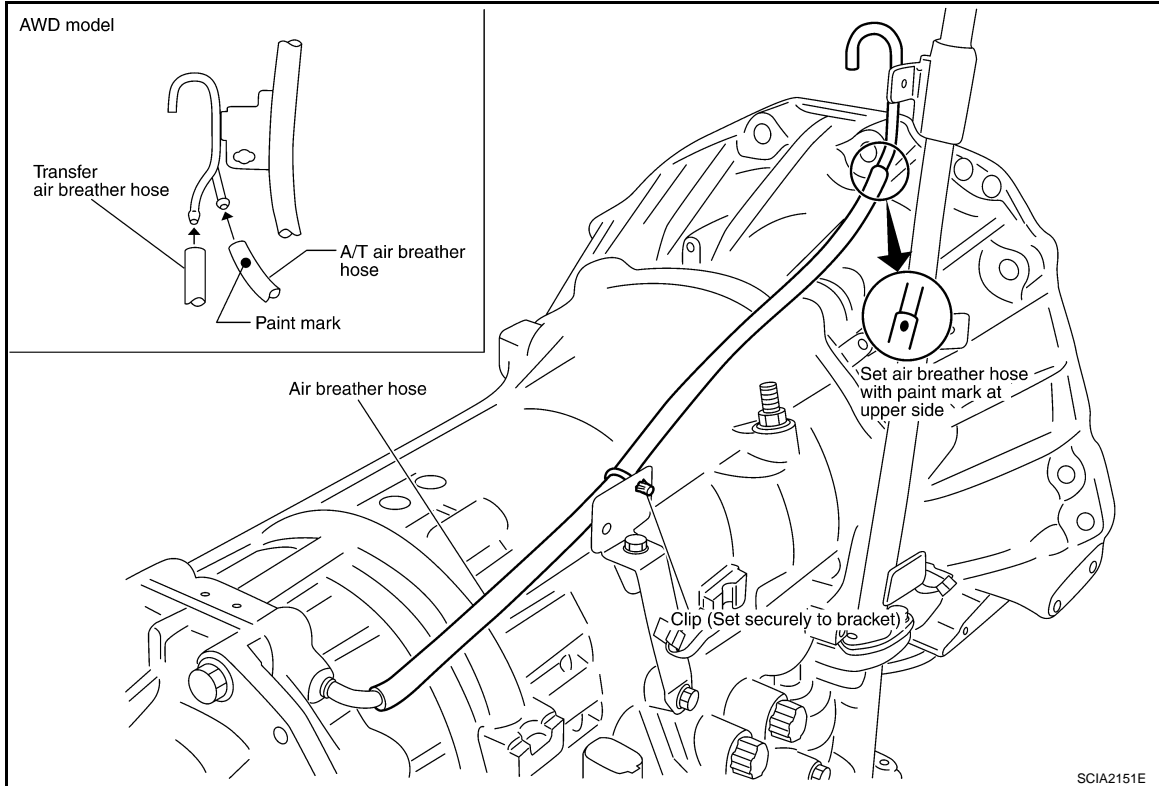

#### CAUTION:

- When installing an air breather hose, be careful not to be crushed or blocked by folding or bending the hose.
- When inserting a hose to the transmission tube, be sure to insert it fully until its end reaches the tube bend R portion.

#### VK45DE ENGINE MODEL

A  
B  
AT  
D  
E  
F  
G  
H  
I  
J  
K  
L  
M  
N  
O  
P

## AIR BREATHER HOSE

### < SERVICE INFORMATION >

Refer to the figure below for air breather hose removal and installation procedure.

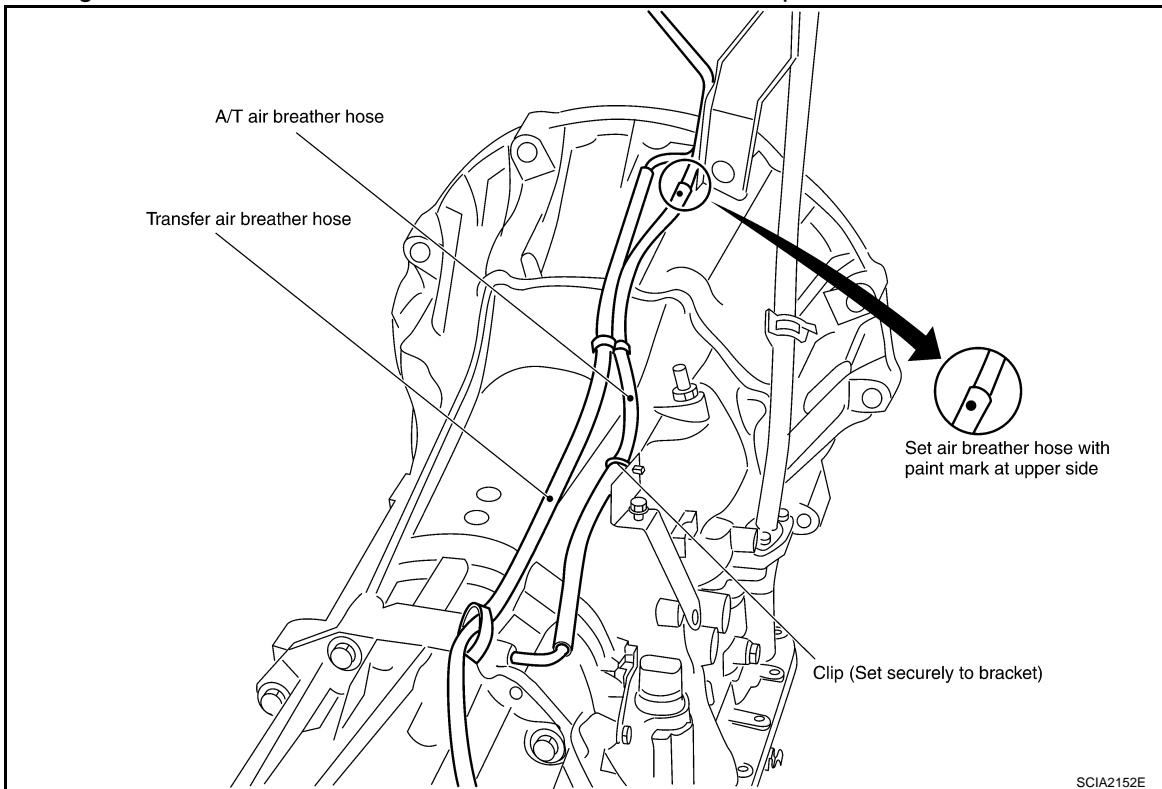

### **CAUTION:**

- When installing an air breather hose, be careful not to be crushed or blocked by folding or bending the hose.
- When inserting a hose to the transmission tube, be sure to insert it fully until its end reaches the tube bend R portion.



# TRANSMISSION ASSEMBLY

< SERVICE INFORMATION >

## TRANSMISSION ASSEMBLY

### Removal and Installation (2WD Models)

INFOID:000000001327398

#### COMPONENTS

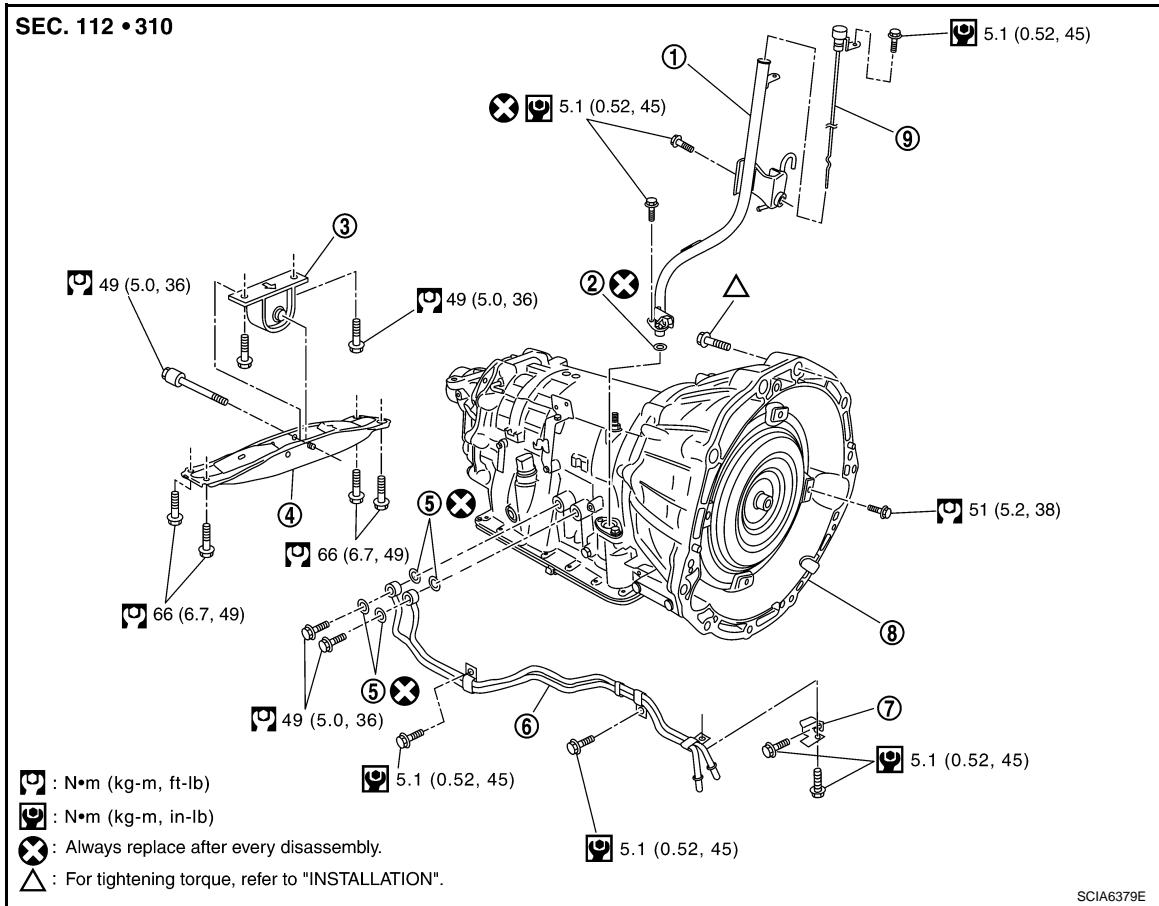

- |                                |                  |                                     |
|--------------------------------|------------------|-------------------------------------|
| 1. A/T fluid charging pipe     | 2. O-ring        | 3. Engine mounting insulator (rear) |
| 4. Rear engine mounting member | 5. Copper washer | 6. Fluid cooler tube                |
| 7. Bracket                     | 8. A/T assembly  | 9. A/T fluid level gauge            |

#### REMOVAL

##### CAUTION:

- When removing the A/T assembly from engine, first remove the crankshaft position sensor (POS) from the A/T assembly.
- Be careful not to damage sensor edge.

1. Disconnect the battery cable from the negative terminal.
2. Remove engine cover.
3. Remove A/T fluid level gauge.
4. Remove engine under cover with power tool.
5. Remove front cross bar. Refer to [FSU-6. "Removal and Installation"](#)
6. Remove exhaust front tube and center muffler with power tool. Refer to [EX-3. "Component"](#).
7. Remove three way catalyst. Refer to [EM-26. "Removal and Installation"](#).
8. Remove rear propeller shaft. Refer to [PR-9. "Removal and Installation"](#).
9. Remove control rod. Refer to [AT-206. "Control Rod Removal and Installation"](#).

# TRANSMISSION ASSEMBLY

## < SERVICE INFORMATION >

10. Remove crankshaft position sensor (POS) from A/T assembly.

**CAUTION:**

- Do not subject it to impact by dropping or hitting it.
- Do not disassemble.
- Do not allow metal filings, etc. to get on the sensor's front edge magnetic area.
- Do not place in an area affected by magnetism.

11. Remove starter motor. Refer to [SC-14, "Removal and Installation \[VQ35DE Engine Models \(2WD\)\]"](#).

12. Remove fluid cooler tube.

13. Remove rear plate cover. Refer to [EM-30, "Removal and Installation \(2WD Models\)"](#).

14. Remove rear cover plate. Refer to [EM-30, "Removal and Installation \(2WD Models\)"](#).

15. Turn crankshaft, and remove the four tightening bolts for drive plate and torque converter.

**CAUTION:**

**When turning crankshaft, turn it clockwise as viewed from the front of the engine.**

16. Support A/T assembly with a transmission jack.

**CAUTION:**

**When setting the transmission jack, be careful not to allow it to collide against the drain plug.**

17. Remove rear engine mounting member with power tool.

18. Remove engine mounting insulator (rear).

19. Remove air breather hose. Refer to [AT-239, "Removal and Installation"](#).

20. Disconnect A/T assembly harness connector.

21. Remove A/T fluid charging pipe from A/T assembly.

22. Remove O-ring from A/T fluid charging pipe.

23. Plug up openings such as the A/T fluid charging pipe hole, etc.

24. Remove bolts fixing A/T assembly to engine assembly with power tool.

25. Remove A/T assembly from vehicle with a transmission jack.

- Secure torque converter to prevent it from dropping.
- Secure A/T assembly to a transmission jack.

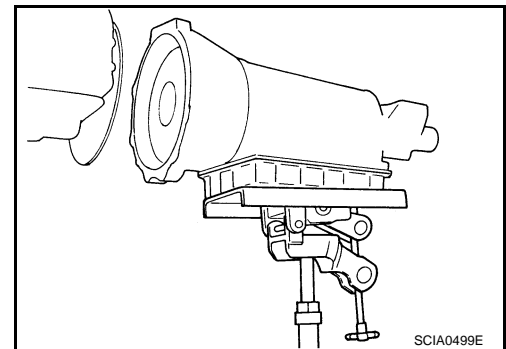
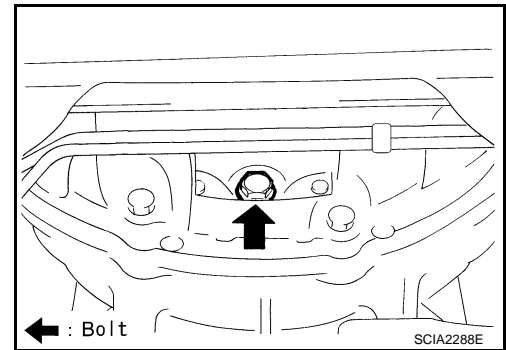
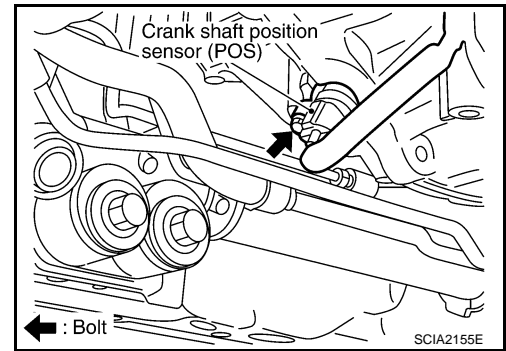

## INSPECTION

Installation and Inspection of Torque Converter

- After inserting a torque converter to a A/T, be sure to check distance "A" to ensure it is within the reference value limit.

**Distance "A" : 25.0 mm (0.98 in) or more**

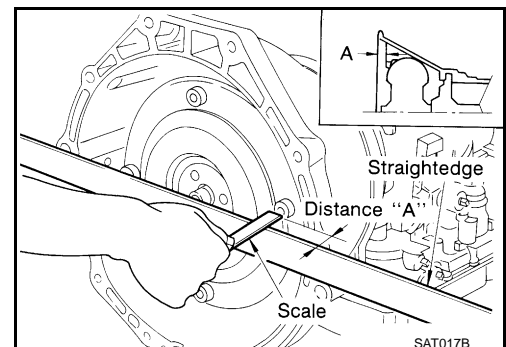

# TRANSMISSION ASSEMBLY

## < SERVICE INFORMATION >

### INSTALLATION

Install the removed parts in the reverse order of the removal, while paying attention to the following work.

- When installing A/T assembly to the engine assembly, attach the fixing bolts in accordance with the following standard.

Bolt No.	1	2	3	4
Number of bolts	1	5	2	2
Bolt length “ℓ”mm (in)	55 (2.17)	65 (2.56)	65 (2.56)	35 (1.38)
Tightening torque N·m (kg·m, ft·lb)	75 (7.7, 55)		55 (5.6, 41)	47 (4.8, 35)

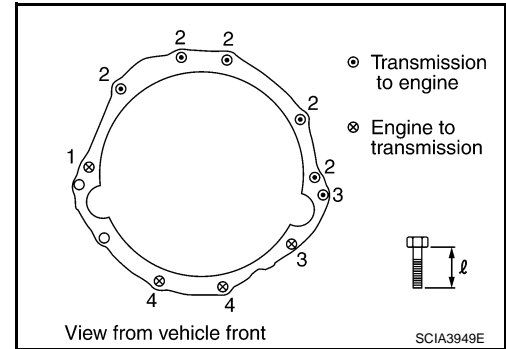

- Align the positions of tightening bolts for drive plate with those of the torque converter, and temporarily tighten the bolts. Then, tighten the bolts with the specified torque. Refer to "COMPONENTS".

### CAUTION:

- Do not reuse O-ring and copper washers.
- When turning crankshaft, turn it clockwise as viewed from the front of the engine.
- When tightening the tightening bolts for the torque converter after fixing the crankshaft pulley bolts, be sure to confirm the tightening torque of the crankshaft pulley mounting bolts. Refer to [EM-65, "Removal and Installation"](#).
- After converter is installed to drive plate, rotate crankshaft several turns and check to be sure that transmission rotates freely without binding.
- Install crankshaft position sensor (POS). Refer to [EM-30, "Removal and Installation \(2WD Models\)"](#).
- After completing installation, check A/T fluid leakage, A/T fluid level, and the A/T positions of A/T. Refer to [AT-11, "Checking A/T Fluid"](#); [AT-207, "Checking of A/T Position"](#).

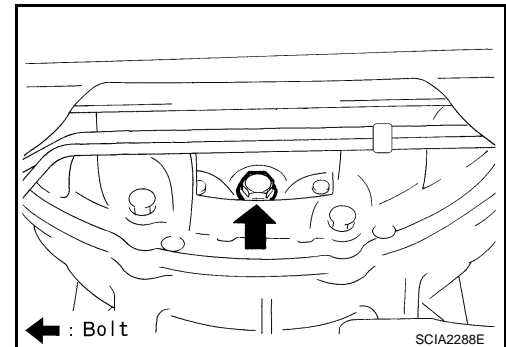

### Removal and Installation (AWD Models)

INFOID:000000001327399

### COMPONENTS (FOR VQ35DE)

# TRANSMISSION ASSEMBLY

< SERVICE INFORMATION >

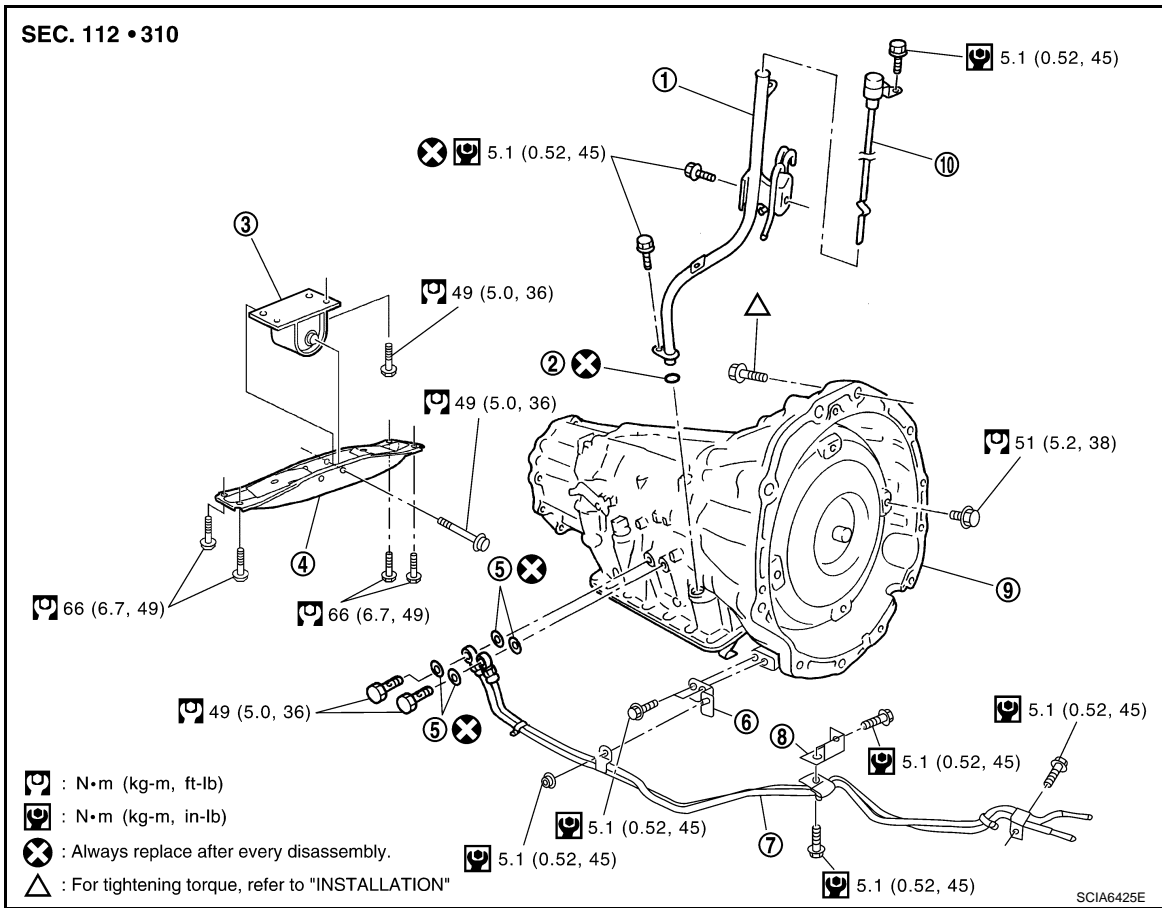

- |                                |                  |                                     |
|--------------------------------|------------------|-------------------------------------|
| 1. A/T fluid charging pipe     | 2. O-ring        | 3. Engine mounting insulator (rear) |
| 4. Rear engine mounting member | 5. Copper washer | 6. Bracket                          |
| 7. Fluid cooler tube           | 8. Bracket       | 9. A/T assembly                     |
| 10. A/T fluid level gauge      |                  |                                     |

## COMPONENTS (FOR VK45DE)

# TRANSMISSION ASSEMBLY

< SERVICE INFORMATION >

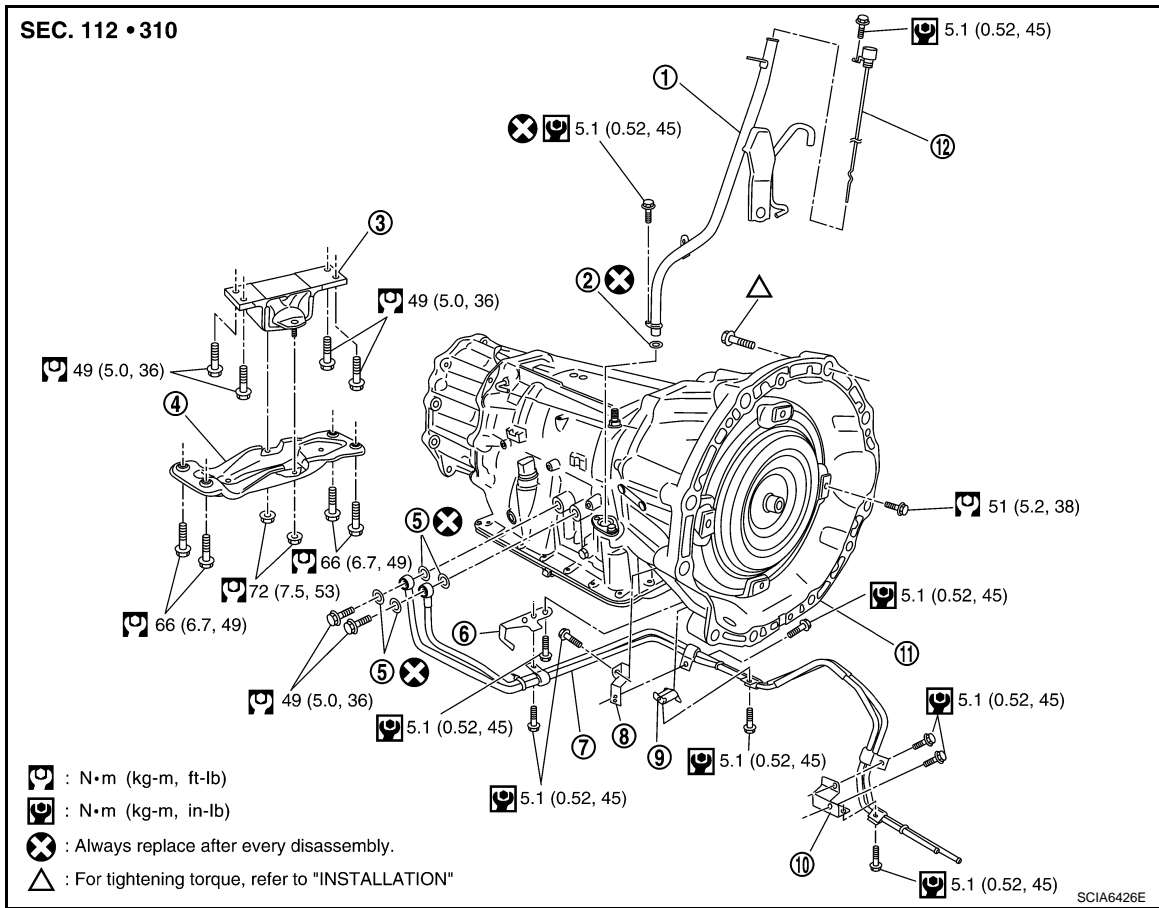

- |                                |                  |                                     |
|--------------------------------|------------------|-------------------------------------|
| 1. A/T fluid charging pipe     | 2. O-ring        | 3. Engine mounting insulator (rear) |
| 4. Rear engine mounting member | 5. Copper washer | 6. Bracket                          |
| 7. Fluid cooler tube           | 8. Bracket       | 9. Bracket                          |
| 10. Bracket                    | 11. A/T assembly | 12. A/T fluid level gauge           |

## REMOVAL

### CAUTION:

- When removing the A/T assembly from engine, first remove the crankshaft position sensor (POS) from the A/T assembly.
- Be careful not to damage sensor edge.

1. Disconnect the battery cable from the negative terminal.
2. Remove engine cover.
3. Remove A/T fluid level gauge.
4. Remove engine under cover with power tool.
5. Remove front cross bar. Refer to [FSU-6, "Removal and Installation"](#).
6. Remove exhaust front tube and center muffler with power tool. Refer to [EX-3, "Component"](#).
7. Remove three way catalyst. Refer to [EM-179, "Removal and Installation"](#).
8. Remove front propeller shaft. Refer to [PR-4, "Removal and Installation"](#).
9. Remove rear propeller shaft. Refer to [PR-9, "Removal and Installation"](#).
10. Remove control rod. Refer to [AT-206, "Control Rod Removal and Installation"](#).

# TRANSMISSION ASSEMBLY

## < SERVICE INFORMATION >

11. Remove crankshaft position sensor (POS) from A/T assembly.

**CAUTION:**

- Do not subject it to impact by dropping or hitting it.
- Do not disassemble.
- Do not allow metal filings, etc., to get on the sensor's front edge magnetic area.
- Do not place in an area affected by magnetism.

12. Remove starter motor. Refer to [SC-15, "Removal and Installation \[VQ35DE Engine Models \(AWD\)\]"](#) (for VQ35DE) or [SC-13, "Removal and Installation \(VK45DE Engine Models\)"](#) (for VK45DE).

13. Disconnect fluid cooler tube from A/T assembly.

14. Remove rear plate cover. Refer to [EM-36, "Removal and Installation \(AWD Models\)"](#) (for VQ35DE) or [EM-183, "Removal and Installation"](#) (for VK45DE).

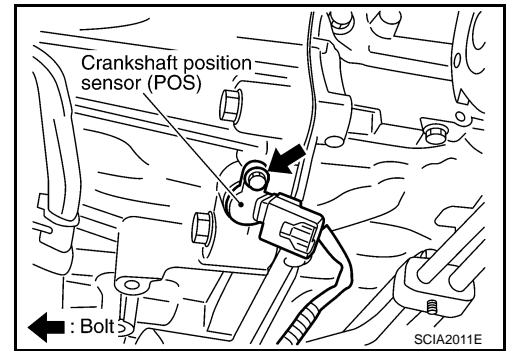

15. Turn crankshaft, and remove the four tightening bolts for drive plate and torque converter.

**CAUTION:**

**When turning crankshaft, turn it clockwise as viewed from the front of the engine.**

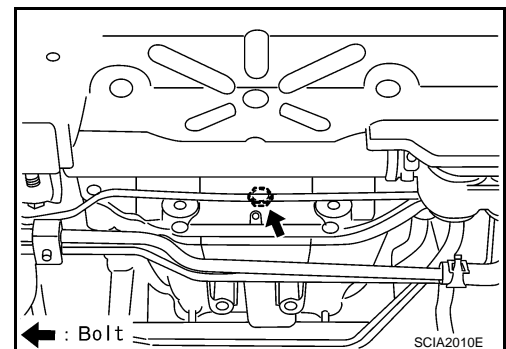
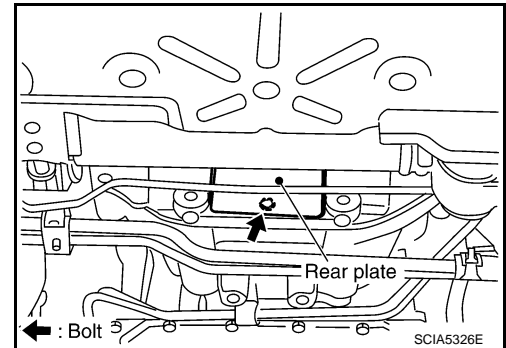

16. Remove dynamic damper (for VQ35DE). Refer to [EM-117, "Removal and Installation \(AWD Models\)"](#).

17. Support A/T assembly with a transmission jack.

**CAUTION:**

**When setting the transmission jack, be careful not to allow it to collide against the drain plug.**

18. Remove rear engine mounting member with power tool.

19. Remove engine mounting insulator (rear).

20. Tilt the A/T assembly slightly to keep the clearance between body and A/T assembly, and then disconnect air breather hose from A/T fluid charging pipe. Refer to [AT-239, "Removal and Installation"](#).

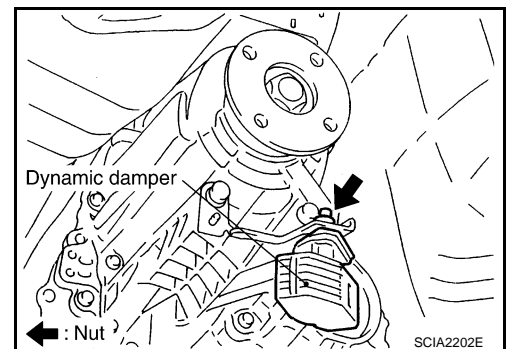

21. Disconnect A/T assembly harness connector and transfer assembly harness connector.

22. Remove A/T fluid charging pipe.

23. Remove O-ring from A/T fluid charging pipe.

24. Plug up openings such as the A/T fluid charging pipe hole, etc.

25. Remove bolts fixing transmission assembly to engine with power tool.

# TRANSMISSION ASSEMBLY

## < SERVICE INFORMATION >

26. Remove A/T assembly with transfer from vehicle.
  - **Secure torque converter to prevent it from dropping.**
  - **Secure A/T assembly to a jack.**
27. Remove transfer from A/T assembly. Refer to [TF-40. "Removal and Installation"](#).

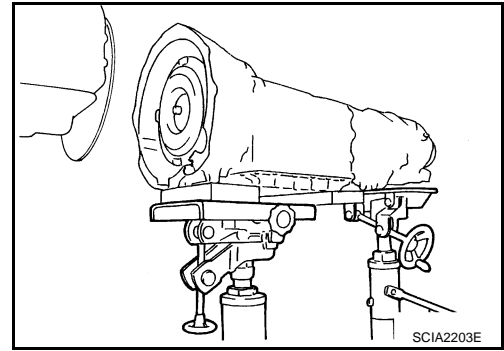

## INSPECTION

### Installation and Inspection of Torque Converter

- After inserting a torque converter to a A/T, be sure to check distance "A" to ensure it is within the reference value limit.

#### Distance "A"

**VQ35DE models : 25.0 mm (0.98 in) or more**

**VK45DE models : 22.0 mm (0.87 in) or more**

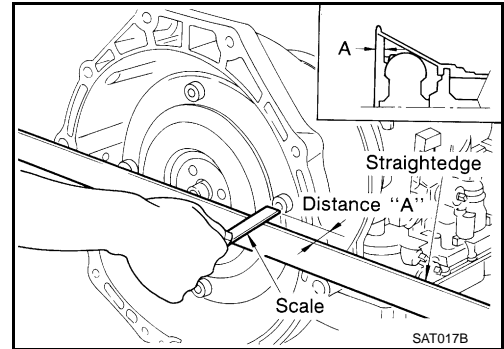

## INSTALLATION

Install the removed parts in the reverse order of the removal, while paying attention to the following work.

- When installing A/T assembly to the engine assembly, attach the fixing bolts in accordance with the following standard.

### For VQ35DE models

Bolt No.	1	2	3	4
Number of bolts	1	5	2	1
Bolt length "ℓ"mm (in)	55 (2.17)	65 (2.56)	35 (1.38)	40 (1.57)
Tightening torque N-m (kg-m, ft-lb)	75 (7.7, 55)		47 (4.8, 35)	34 (3.5, 25)

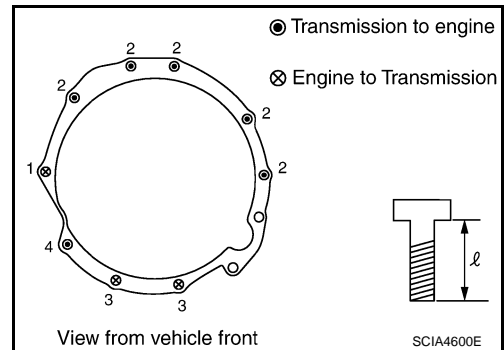

### For VK45DE models

Bolt No.	1	2 <sup>*1</sup>	3	4 <sup>*2</sup>
Number of bolts	4	1	4	1
Bolt length mm (in)	70 (2.76)	70 (2.76)	65 (2.56)	70 (2.76)
Tightening torque N-m (kg-m, ft-lb)	113 (12, 83)		74.0 (7.5, 55)	113 (12,83)

\*1 : No.2 bolt also secures A/T fluid charging pipe and washer.

\*2 : No.4 bolt also secures bracket.

(A) : A/T to engine

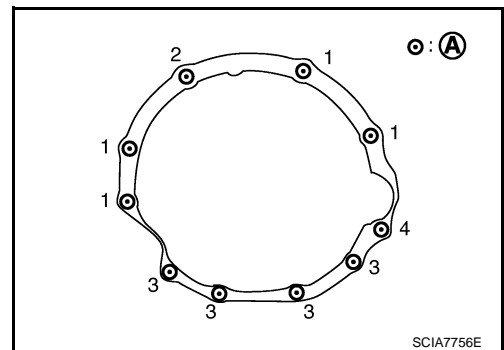



## TRANSMISSION ASSEMBLY

### < SERVICE INFORMATION >

- Align the positions of tightening bolts for drive plate with those of the torque converter, and temporarily tighten the bolts. Then, tighten the bolts with the specified torque. Refer to "COMPONENTS (FOR VQ35DE)" or "COMPONENTS (FOR VK45DE)".

#### **CAUTION:**

- Do not reuse O-ring and copper washers.
- When turning crankshaft, turn it clockwise as viewed from the front of the engine.
- When tightening the tightening bolts for the torque converter after fixing the crankshaft pulley bolts, be sure to confirm the tightening torque of the crankshaft pulley mounting bolts. Refer to [EM-65, "Removal and Installation"](#) (for VQ35DE) or [EM-200, "Removal and Installation"](#) (for VK45DE)
- After converter is installed to drive plate, rotate crankshaft several turns and check to be sure that transmission rotates freely without binding.
- Install crankshaft position sensor (POS). Refer to [EM-35, "Component \(AWD Models\)"](#) (for VQ35DE) or [EM-183, "Component"](#) (for VK45DE).
- After completing installation, check A/T fluid leakage, A/T fluid level, and the positions of A/T. Refer to [AT-11, "Checking A/T Fluid"](#), [AT-207, "Checking of A/T Position"](#).

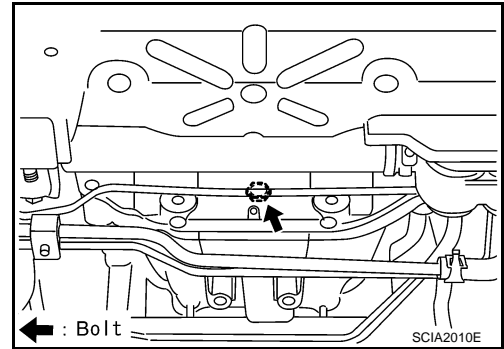



# OVERHAUL

< SERVICE INFORMATION >

## OVERHAUL

Component

INFOID:000000001327400

VQ35DE models

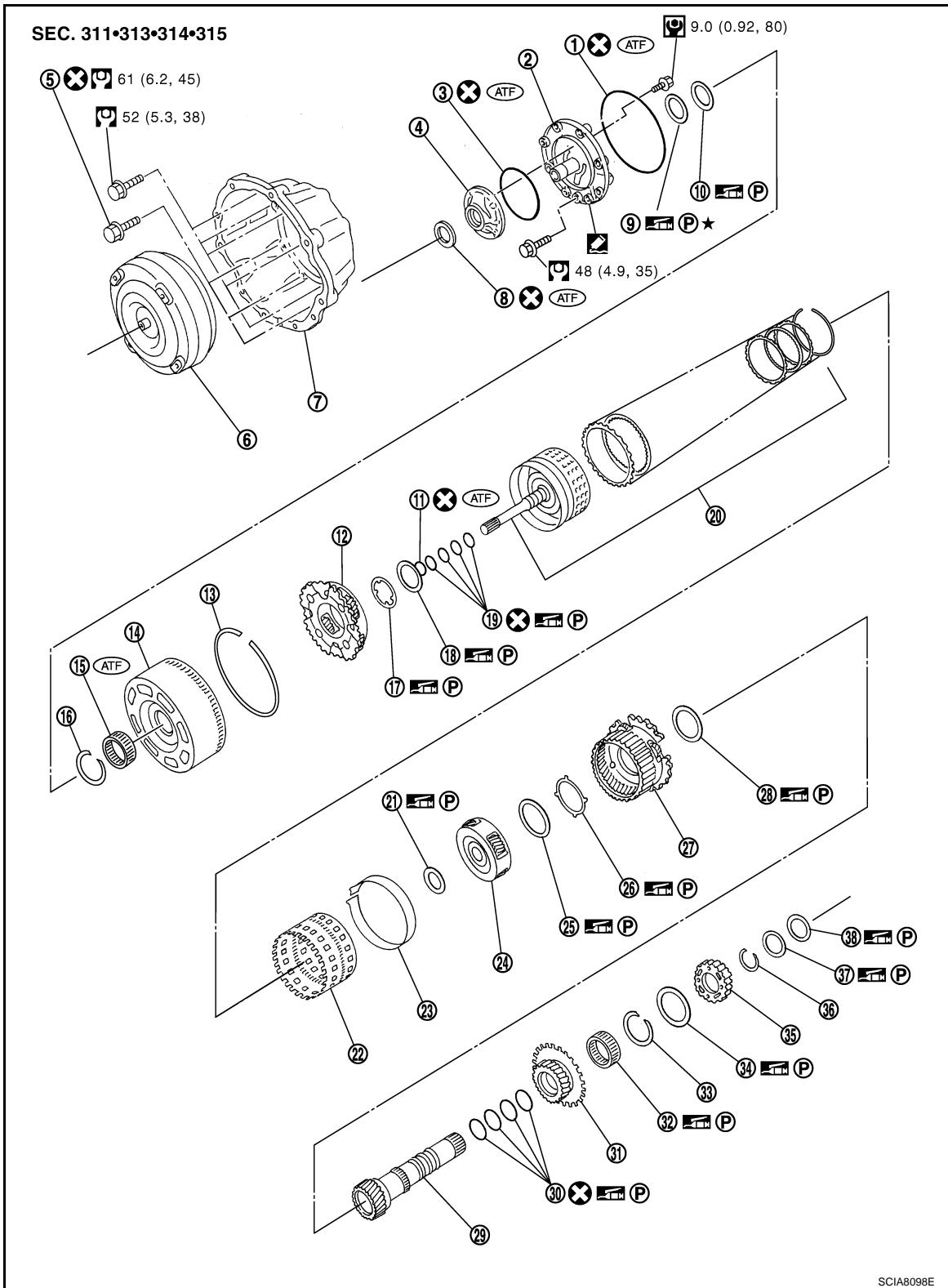

- |                      |                              |                     |
|----------------------|------------------------------|---------------------|
| 1. O-ring            | 2. Oil pump cover            | 3. O-ring           |
| 4. Oil pump housing  | 5. Self-sealing bolt         | 6. Torque converter |
| 7. Converter housing | 8. Oil pump housing oil seal | 9. Bearing race     |

A  
B  
AT  
D  
E  
F  
G  
H  
I  
J  
K  
L  
M  
N  
O  
P

# OVERHAUL

## < SERVICE INFORMATION >

---

- |                        |                                     |                            |
|------------------------|-------------------------------------|----------------------------|
| 10. Needle bearing     | 11. O-ring                          | 12. Front carrier assembly |
| 13. Snap ring          | 14. Front sun gear                  | 15. 3rd one-way clutch     |
| 16. Snap ring          | 17. Bearing race                    | 18. Needle bearing         |
| 19. Seal ring          | 20. Input clutch assembly           | 21. Needle bearing         |
| 22. Rear internal gear | 23. Brake band                      | 24. Mid carrier assembly   |
| 25. Needle bearing     | 26. Bearing race                    | 27. Rear carrier assembly  |
| 28. Needle bearing     | 29. Mid sun gear                    | 30. Seal ring              |
| 31. Rear sun gear      | 32. 1st one-way clutch              | 33. Snap ring              |
| 34. Needle bearing     | 35. High and low reverse clutch hub | 36. Snap ring              |
| 37. Bearing race       | 38. Needle bearing                  |                            |

Refer to GI section to make sure icons (symbol marks) in the figure. Refer to [GI-8. "Component"](#).

However, refer to the following symbol for others.



: Apply Genuine RTV silicone sealant or equivalent. Refer to [GI-44. "Recommended Chemical Product and Sealant"](#).

# OVERHAUL

< SERVICE INFORMATION >

VK45DE models

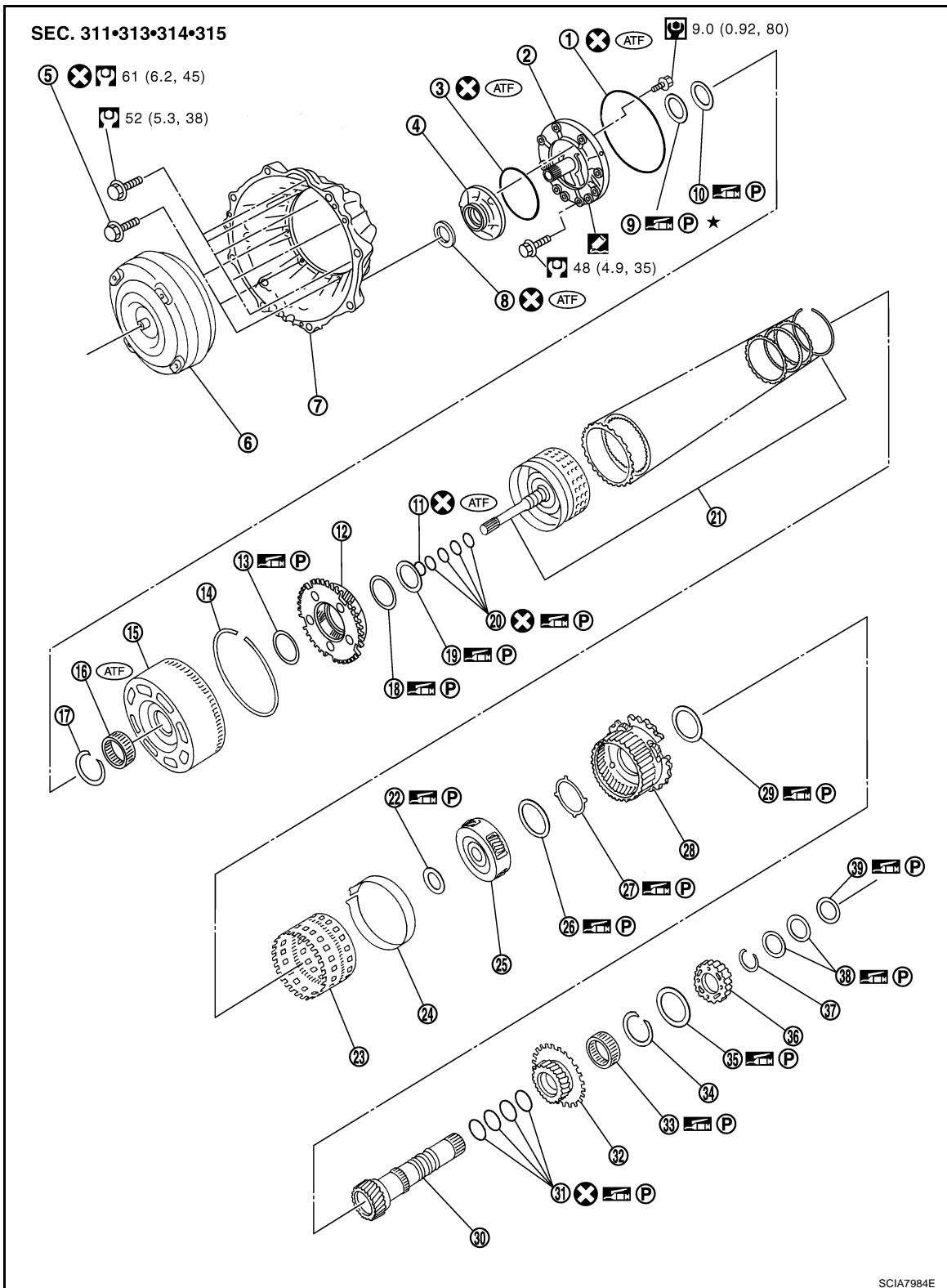

- |                        |                              |                            |
|------------------------|------------------------------|----------------------------|
| 1. O-ring              | 2. Oil pump cover            | 3. O-ring                  |
| 4. Oil pump housing    | 5. Self-sealing bolt         | 6. Torque converter        |
| 7. Converter housing   | 8. Oil pump housing oil seal | 9. Bearing race            |
| 10. Needle bearing     | 11. O-ring                   | 12. Front carrier assembly |
| 13. Needle bearing     | 14. Snap ring                | 15. Front sun gear         |
| 16. 3rd one-way clutch | 17. Snap ring                | 18. Bearing race           |
| 19. Needle bearing     | 20. Seal ring                | 21. Input clutch assembly  |

A  
B  
AT  
D  
E  
F  
G  
H  
I  
J  
K  
L  
M  
N  
O  
P

# OVERHAUL

## < SERVICE INFORMATION >

---

- |                           |                        |                                     |
|---------------------------|------------------------|-------------------------------------|
| 22. Needle bearing        | 23. Rear internal gear | 24. Brake band                      |
| 25. Mid carrier assembly  | 26. Needle bearing     | 27. Bearing race                    |
| 28. Rear carrier assembly | 29. Needle bearing     | 30. Mid sun gear                    |
| 31. Seal ring             | 32. Rear sun gear      | 33. 1st one-way clutch              |
| 34. Snap ring             | 35. Needle bearing     | 36. High and low reverse clutch hub |
| 37. Snap ring             | 38. Bearing race       | 39. Needle bearing                  |

Refer to GI section to make sure icons (symbol marks) in the figure. Refer to [GI-8, "Component"](#).

However, refer to the following symbols for others.



: Apply Genuine RTV silicone sealant or equivalent. Refer to [GI-44, "Recommended Chemical Product and Sealant"](#).

# OVERHAUL

< SERVICE INFORMATION >

VQ35DE models

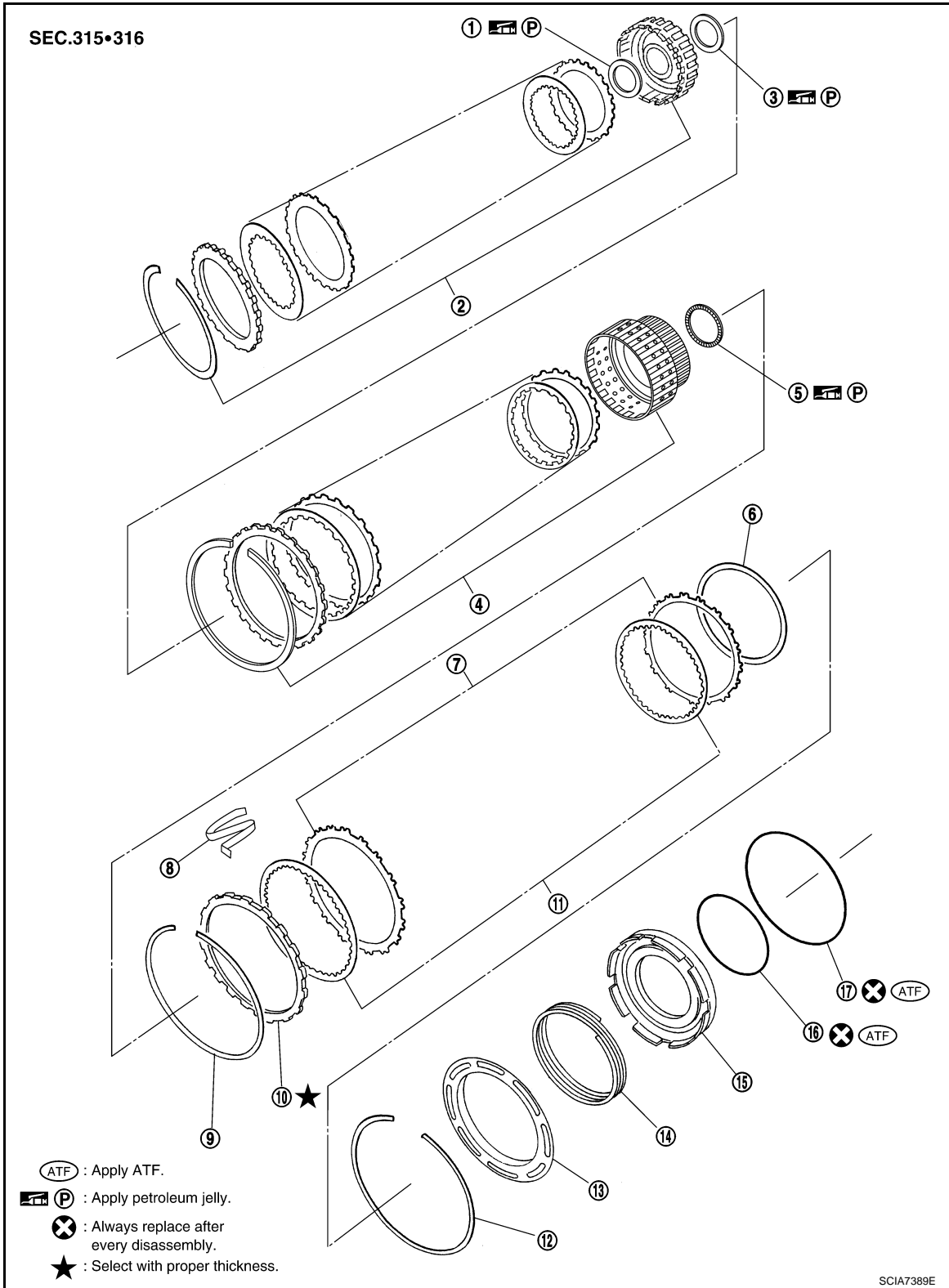

- |                                   |   |                             |
|-----------------------------------|---|-----------------------------|
| 1. Bearing race                   | 2. High and low reverse clutch assembly | 3. Needle bearing           |
| 4. Direct clutch assembly         | 5. Needle bearing                       | 6. Reverse brake dish plate |
| 7. Reverse brake driven plate     | 8. N-spring                             | 9. Snap ring                |
| 10. Reverse brake retaining plate | 11. Reverse brake drive plate           | 12. Snap ring               |
| 13. Spring retainer               | 14. Return spring                       | 15. Reverse brake piston    |
| 16. D-ring                        | 17. D-ring                              |                             |

A  
B  
AT  
D  
E  
F  
G  
H  
I  
J  
K  
L  
M  
N  
O  
P

# OVERHAUL

< SERVICE INFORMATION >

VK45DE models

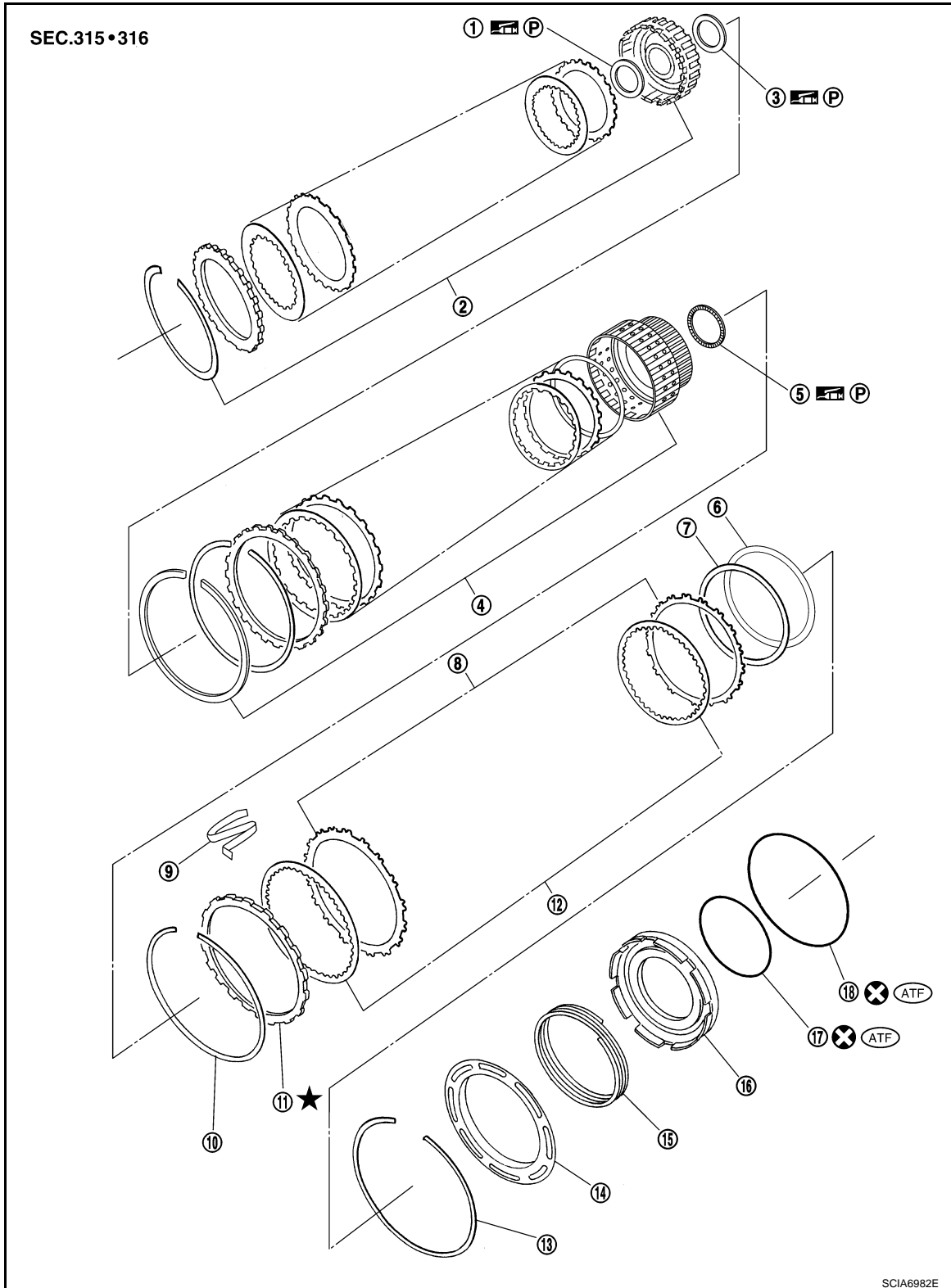

- |                             |   |                               |
|-----------------------------|---|-------------------------------|
| 1. Bearing race             | 2. High and low reverse clutch assembly | 3. Needle bearing             |
| 4. Direct clutch assembly   | 5. Needle bearing                       | 6. Reverse brake dish plate   |
| 7. Reverse brake dish plate | 8. Reverse brake driven plate           | 9. N-spring                   |
| 10. Snap ring               | 11. Reverse brake retaining plate       | 12. Reverse brake drive plate |
| 13. Snap ring               | 14. Spring retainer                     | 15. Return spring             |
| 16. Reverse brake piston    | 17. D-ring                              | 18. D-ring                    |

Refer to GI section to make sure icons (symbol marks) in the figure. Refer to [GI-8, "Component"](#).

# OVERHAUL

< SERVICE INFORMATION >

2WD models

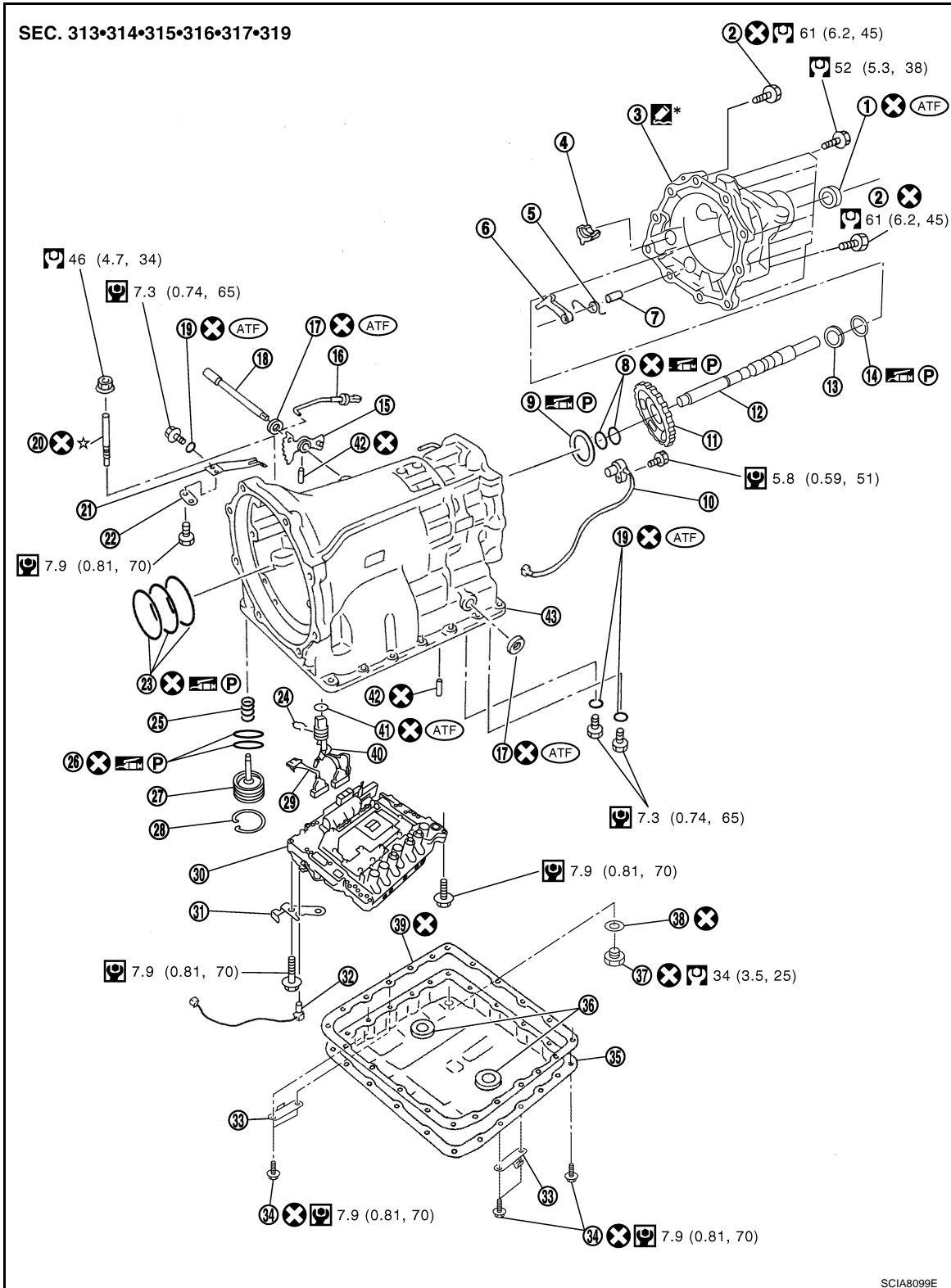

- |                             |                               |                   |
|-----------------------------|-------------------------------|-------------------|
| 1. Rear oil seal            | 2. Self-sealing bolt          | 3. Rear extension |
| 4. Parking actuator support | 5. Return spring              | 6. Parking pawl   |
| 7. Pawl shaft               | 8. Seal ring                  | 9. Needle bearing |
| 10. Revolution sensor       | 11. Parking gear              | 12. Output shaft  |
| 13. Bearing race            | 14. Needle bearing            | 15. Manual plate  |
| 16. Parking rod             | 17. Manual shaft oil seal     | 18. Manual shaft  |
| 19. O-ring                  | 20. Band servo anchor end pin | 21. Detent spring |

A  
B  
AT  
D  
E  
F  
G  
H  
I  
J  
K  
L  
M  
N  
O  
P

# OVERHAUL

## < SERVICE INFORMATION >

---

- |                            |                                    |                            |
|----------------------------|------------------------------------|----------------------------|
| 22. Spacer                 | 23. Seal ring                      | 24. Snap ring              |
| 25. Return spring          | 26. O-ring                         | 27. Servo assembly         |
| 28. Snap ring              | 29. Sub-harness                    | 30. Control valve with TCM |
| 31. Bracket                | 32. A/T fluid temperature sensor 2 | 33. Clip                   |
| 34. Oil pan mounting bolt  | 35. Oil pan                        | 36. Magnet                 |
| 37. Drain plug             | 38. Drain plug gasket              | 39. Oil pan gasket         |
| 40. Terminal cord assembly | 41. O-ring                         | 42. Retaining pin          |
| 43. Transmission case      |                                    |                            |

Refer to GI section to make sure icons (symbol marks) in the figure. Refer to [GI-8. "Component"](#).

However, refer to the following symbol for others.



: Apply Genuine Anaerobic Liquid Gasket or equivalent. Refer to [GI-44. "Recommended Chemical Product and Sealant"](#).



# OVERHAUL

< SERVICE INFORMATION >

VQ35DE models for AWD

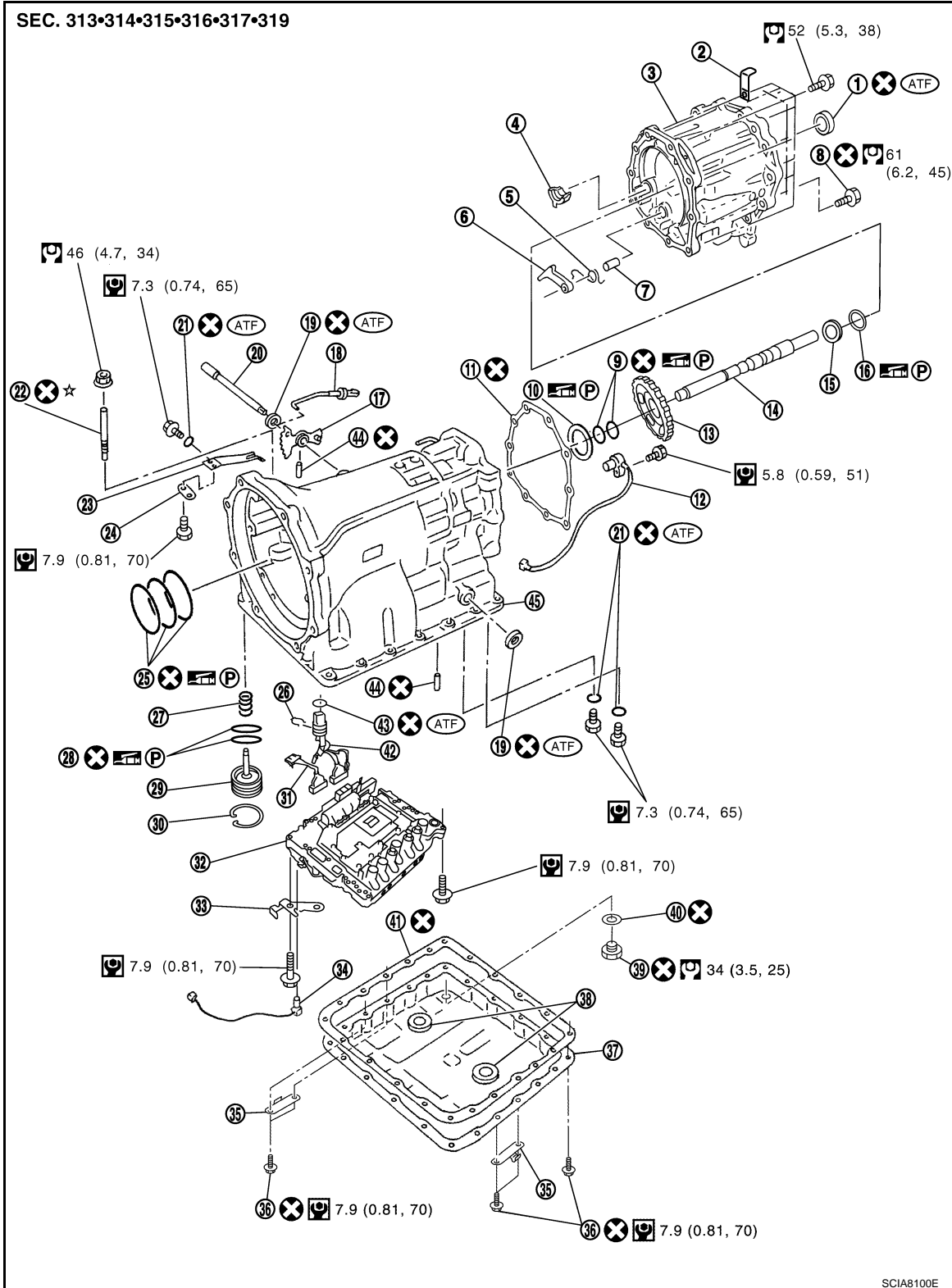

- |                             |                      |                       |
|-----------------------------|----------------------|-----------------------|
| 1. Rear oil seal            | 2. Bracket           | 3. Adapter case       |
| 4. Parking actuator support | 5. Return spring     | 6. Parking pawl       |
| 7. Pawl shaft               | 8. Self-sealing bolt | 9. Seal ring          |
| 10. Needle bearing          | 11. Gasket           | 12. Revolution sensor |
| 13. Parking gear            | 14. Output shaft     | 15. Bearing race      |
| 16. Needle bearing          | 17. Manual plate     | 18. Parking rod       |
| 19. Manual shaft oil seal   | 20. Manual shaft     | 21. O-ring            |

A  
B  
AT  
D  
E  
F  
G  
H  
I  
J  
K  
L  
M  
N  
O  
P

# OVERHAUL

## < SERVICE INFORMATION >

---

- |                                    |                            |                            |
|------------------------------------|----------------------------|----------------------------|
| 22. Band servo anchor end pin      | 23. Detent spring          | 24. Spacer                 |
| 25. Seal ring                      | 26. Snap ring              | 27. Return spring          |
| 28. O-ring                         | 29. Servo assembly         | 30. Snap ring              |
| 31. Sub-harness                    | 32. Control valve with TCM | 33. Bracket                |
| 34. A/T fluid temperature sensor 2 | 35. Clip                   | 36. Oil pan mounting bolt  |
| 37. Oil pan                        | 38. Magnet                 | 39. Drain plug             |
| 40. Drain plug gasket              | 41. Oil pan gasket         | 42. Terminal cord assembly |
| 43. O-ring                         | 44. Retaining pin          | 45. Transmission case      |

Refer to GI section to make sure icons (symbol marks) in the figure. Refer to [GI-8. "Component"](#).

# OVERHAUL

< SERVICE INFORMATION >

VK45DE models for 4WD

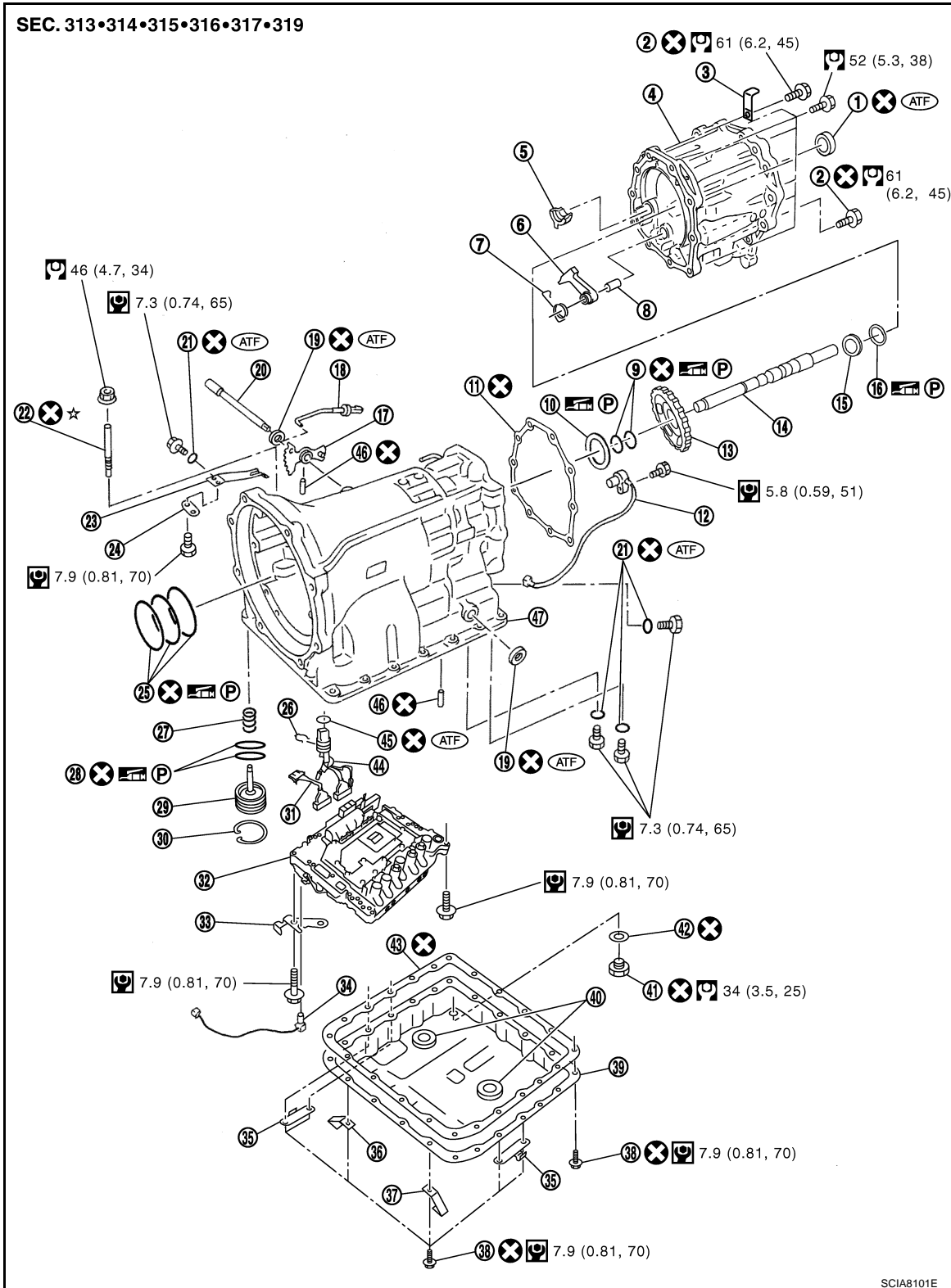

- |                           |                             |                       |
|---------------------------|-----------------------------|-----------------------|
| 1. Rear oil seal          | 2. Self-sealing bolt        | 3. Bracket            |
| 4. Adapter case           | 5. Parking actuator support | 6. Parking pawl       |
| 7. Return spring          | 8. Pawl shaft               | 9. Seal ring          |
| 10. Needle bearing        | 11. Gasket                  | 12. Revolution sensor |
| 13. Parking gear          | 14. Output shaft            | 15. Bearing race      |
| 16. Needle bearing        | 17. Manual plate            | 18. Parking rod       |
| 19. Manual shaft oil seal | 20. Manual shaft            | 21. O-ring            |

A  
B  
AT  
D  
E  
F  
G  
H  
I  
J  
K  
L  
M  
N  
O  
P

# OVERHAUL

## < SERVICE INFORMATION >

---

- |                                    |                            |                       |
|------------------------------------|----------------------------|-----------------------|
| 22. Band servo anchor end pin      | 23. Detent spring          | 24. Spacer            |
| 25. Seal ring                      | 26. Snap ring              | 27. Return spring     |
| 28. O-ring                         | 29. Servo assembly         | 30. Snap ring         |
| 31. Sub-harness                    | 32. Control valve with TCM | 33. Bracket           |
| 34. A/T fluid temperature sensor 2 | 35. Clip                   | 36. Bracket           |
| 37. Bracket                        | 38. Oil pan mounting bolt  | 39. Oil pan           |
| 40. Magnet                         | 41. Drain plug             | 42. Drain plug gasket |
| 43. Oil pan gasket                 | 44. Terminal cord assembly | 45. O-ring            |
| 46. Retaining pin                  | 47. Transmission case      |                       |

Refer to GI section to make sure icons (symbol marks) in the figure. Refer to [GI-8. "Component"](#).

# OVERHAUL

< SERVICE INFORMATION >

## Oil Channel

INFOID:000000001327401

A  
B  
AT  
D  
E  
F  
G  
H  
I  
J  
K  
L  
M  
N  
O  
P

### 2WD models

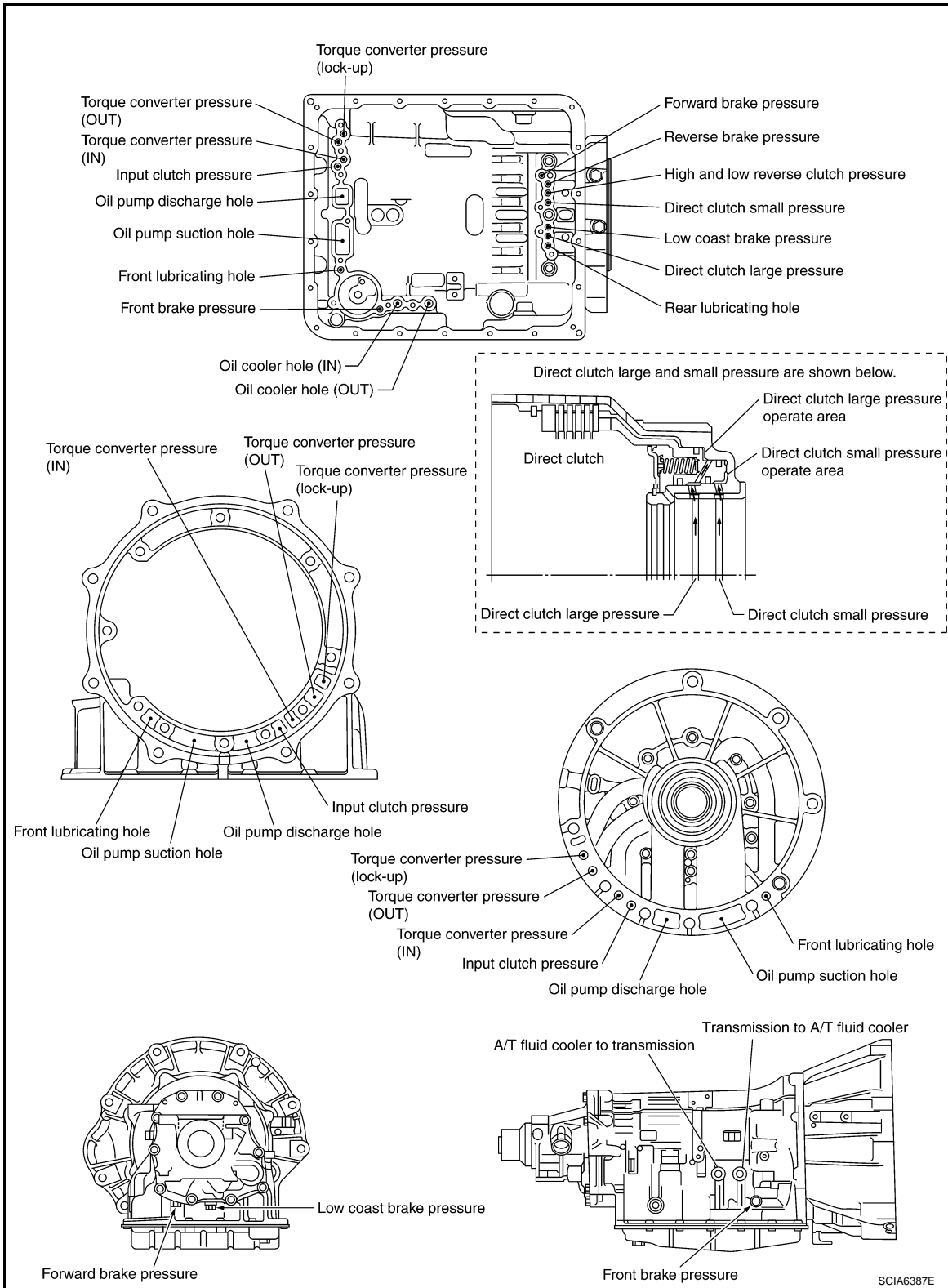

SCIA6387E

# OVERHAUL

< SERVICE INFORMATION >

VQ35DE models for AWD

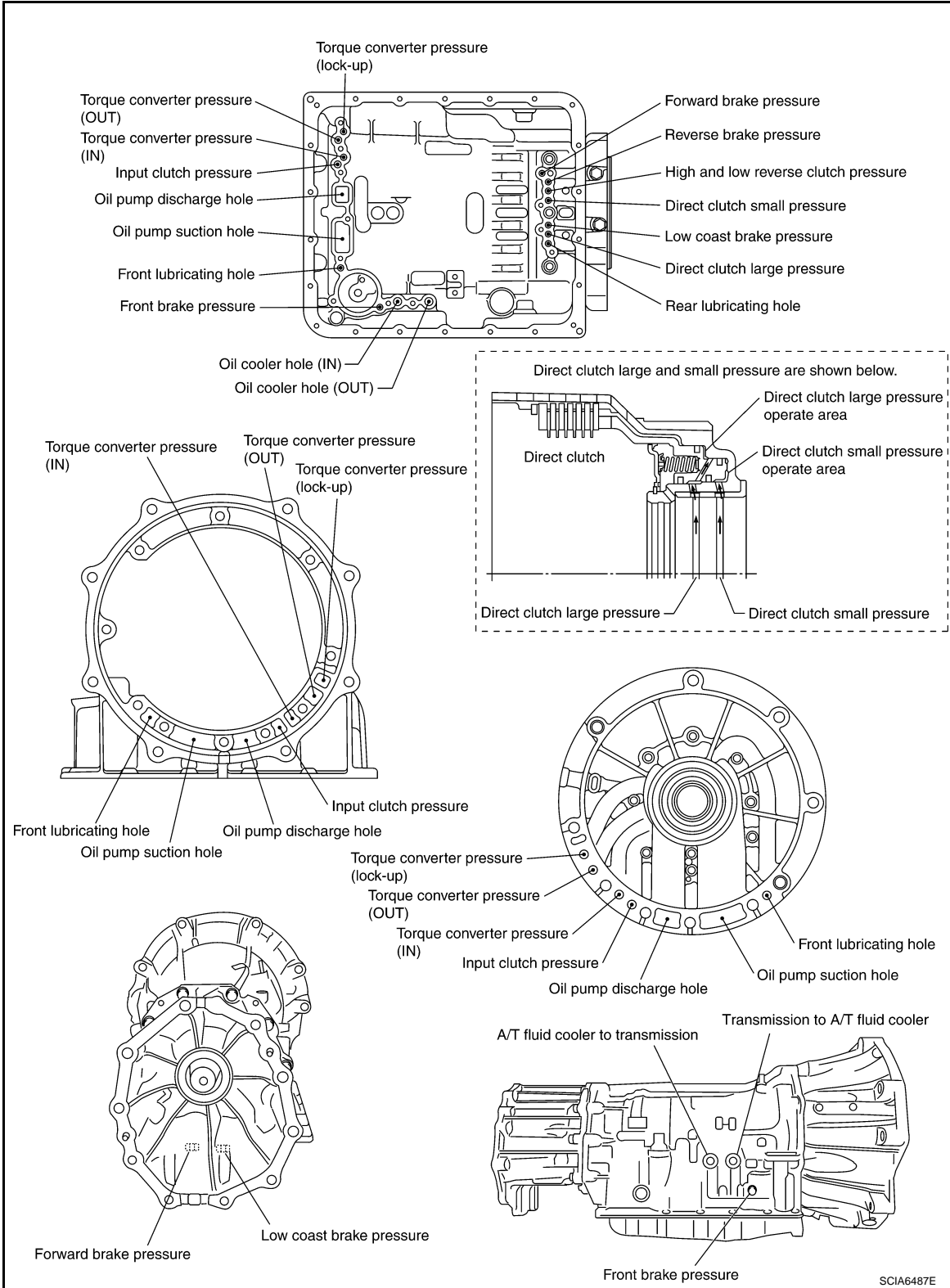

SCIA6487E

# OVERHAUL

< SERVICE INFORMATION >

VK45DE models for AWD

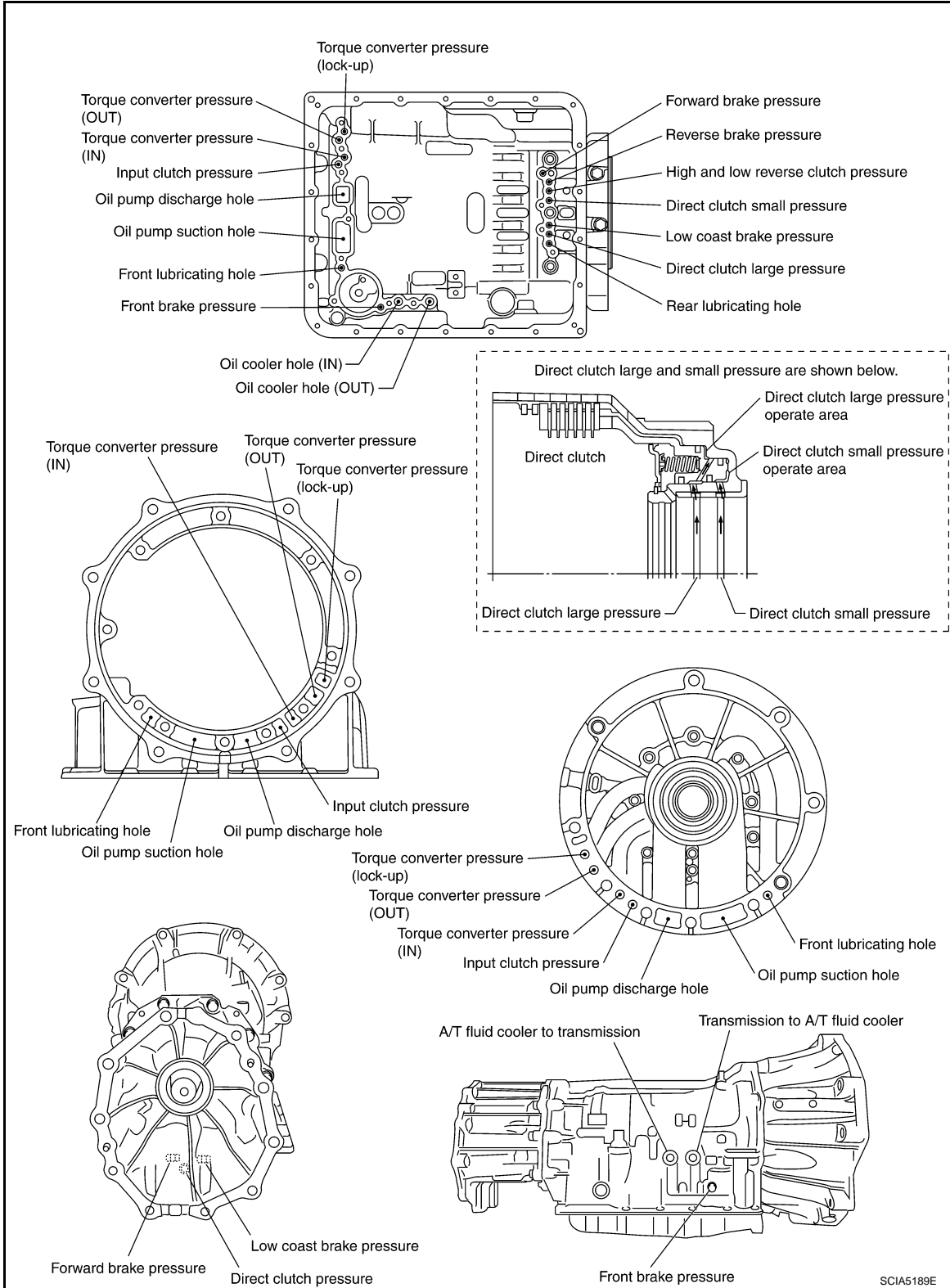

A  
B  
AT  
D  
E  
F  
G  
H  
I  
J  
K  
L  
M  
N  
O  
P

# OVERHAUL

< SERVICE INFORMATION >

## Location of Adjusting Shims, Needle Bearings, Thrust Washers and Snap Rings

INFOID:000000001327402

2WD models

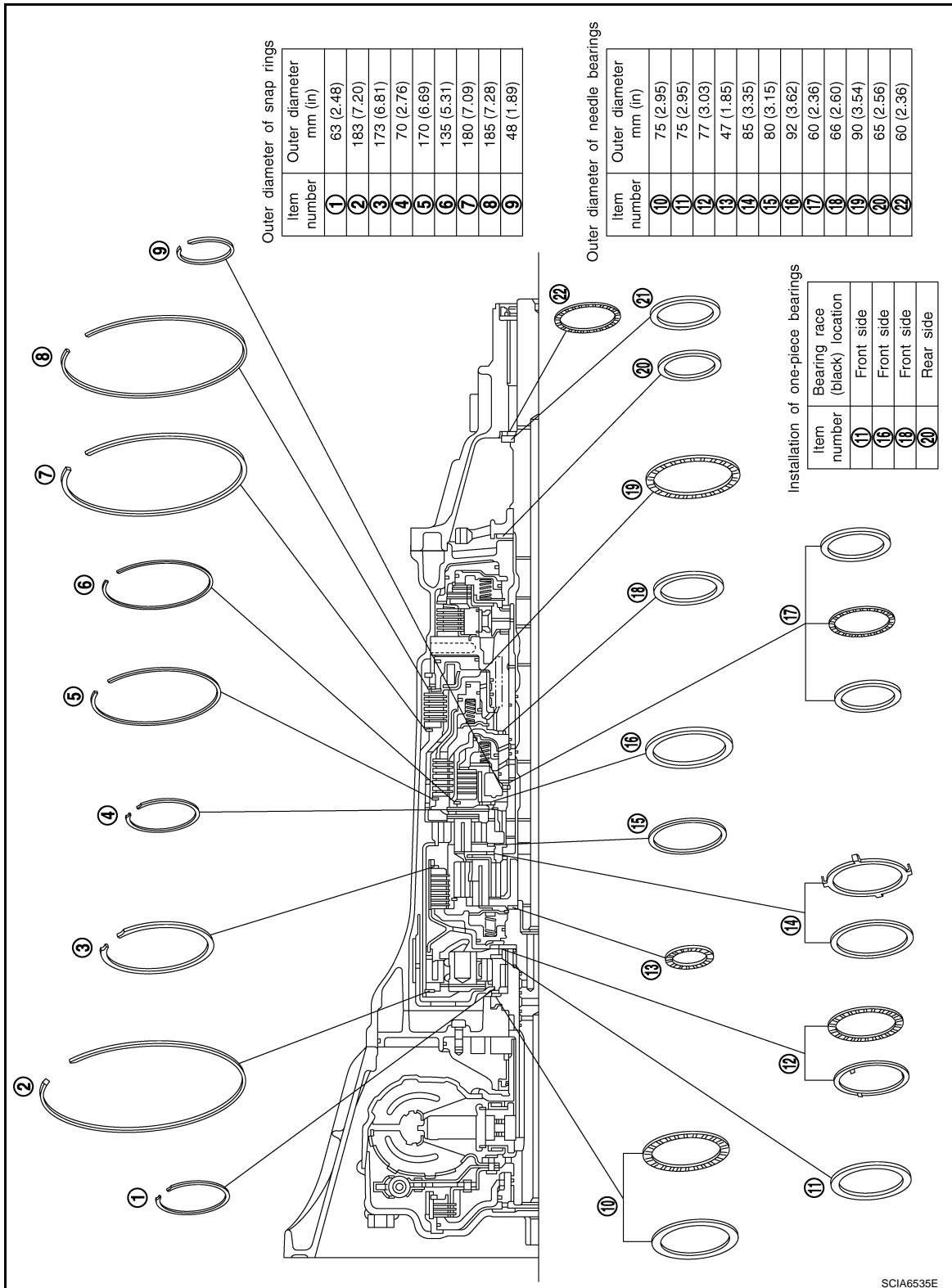

SCIA6535E



# OVERHAUL

< SERVICE INFORMATION >

## VQ35DE models for AWD

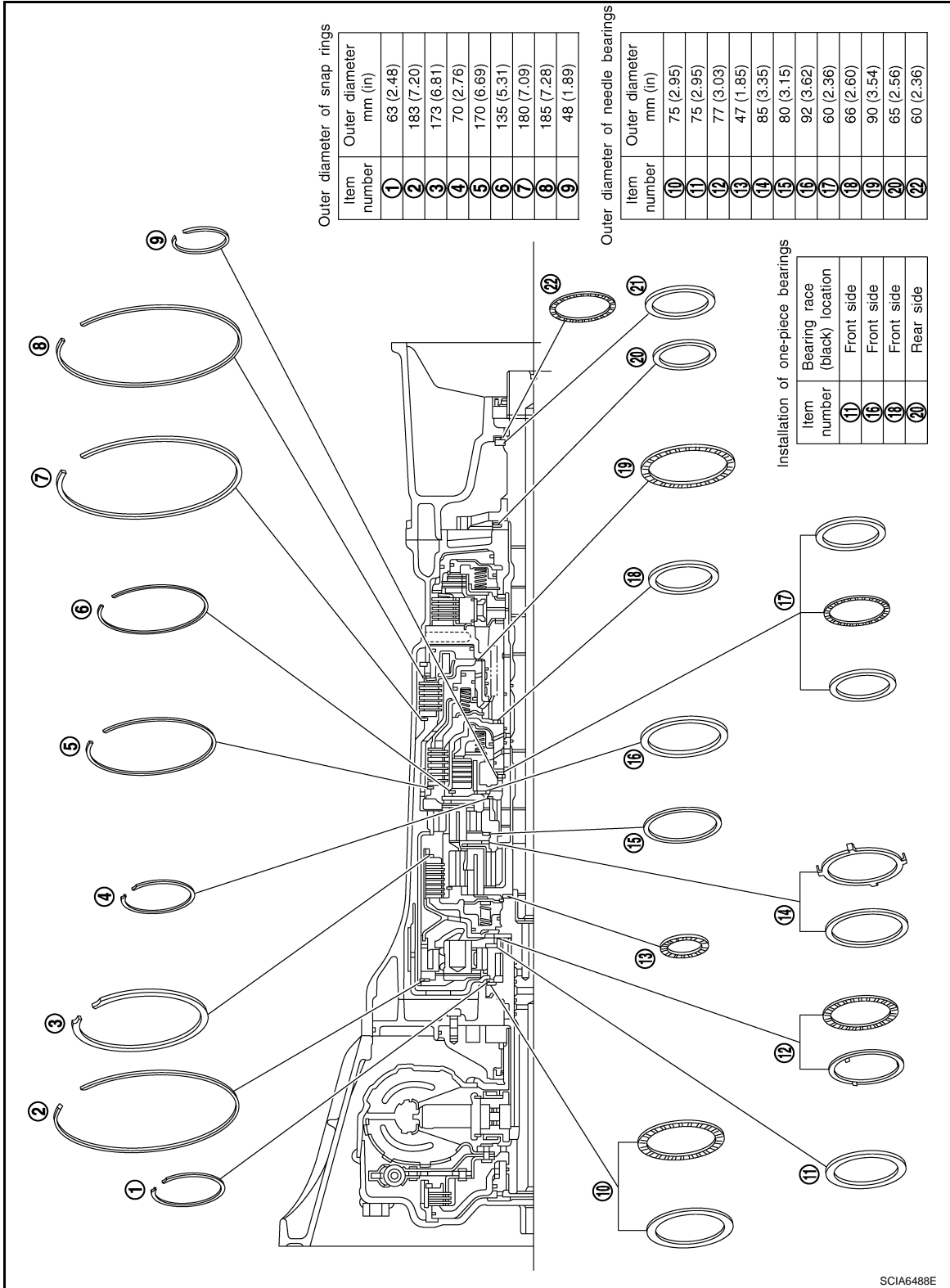

Outer diameter of snap rings

Item number	Outer diameter mm (in)
1	63 (2.48)
2	183 (7.20)
3	173 (6.81)
4	70 (2.76)
5	170 (6.69)
6	135 (5.31)
7	180 (7.09)
8	185 (7.28)
9	48 (1.89)

Outer diameter of needle bearings

Item number	Outer diameter mm (in)
10	75 (2.95)
11	75 (2.95)
12	77 (3.03)
13	47 (1.85)
14	85 (3.35)
15	80 (3.15)
16	92 (3.62)
17	60 (2.36)
18	66 (2.60)
19	90 (3.54)
20	65 (2.56)
22	60 (2.36)

Installation of one-piece bearings

Item number	Bearing race (black) location
11	Front side
16	Front side
18	Front side
20	Rear side

A  
B  
AT  
D  
E  
F  
G  
H  
I  
J  
K  
L  
M  
N  
O  
P

# OVERHAUL

< SERVICE INFORMATION >

## VK45DE models for AWD

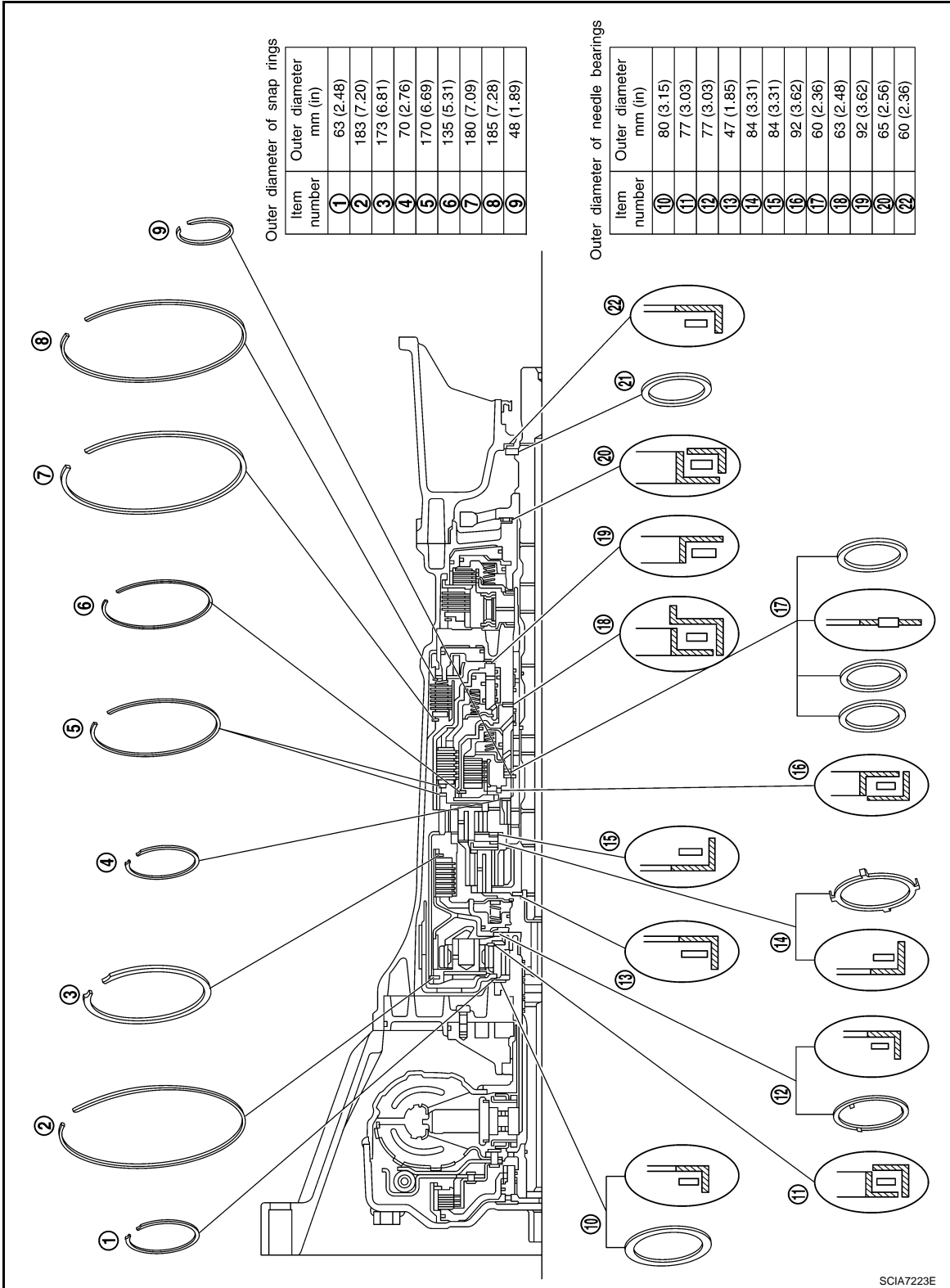

SCIA7223E

# DISASSEMBLY

< SERVICE INFORMATION >

## DISASSEMBLY

### Disassembly

INFOID:000000001327403

#### CAUTION:

Do not disassemble parts behind drum support. Refer to [AT-16, "Cross-Sectional View \(2WD Models\)"](#), [AT-17, "Cross-Sectional View \(VQ35DE Models for AWD\)"](#) or [AT-18, "Cross-Sectional View \(VK45DE Models for AWD\)"](#).

1. Drain ATF through drain plug.
2. Remove torque converter by holding it firmly and turning while pulling straight out.

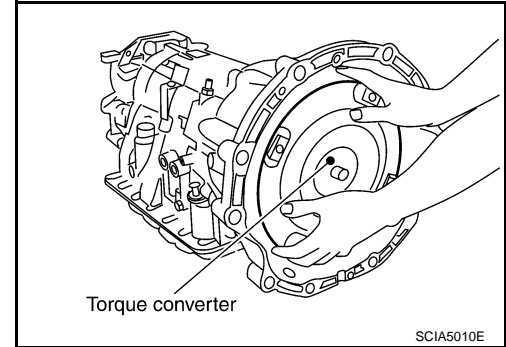

3. Check torque converter one-way clutch using check tool as shown in the figure.
  - a. Insert check tool into the groove of bearing support built into one-way clutch outer race.
  - b. When fixing bearing support with check tool, rotate one-way clutch spline using screwdriver.
  - c. Make sure that inner race rotates clockwise only. If not, replace torque converter assembly.

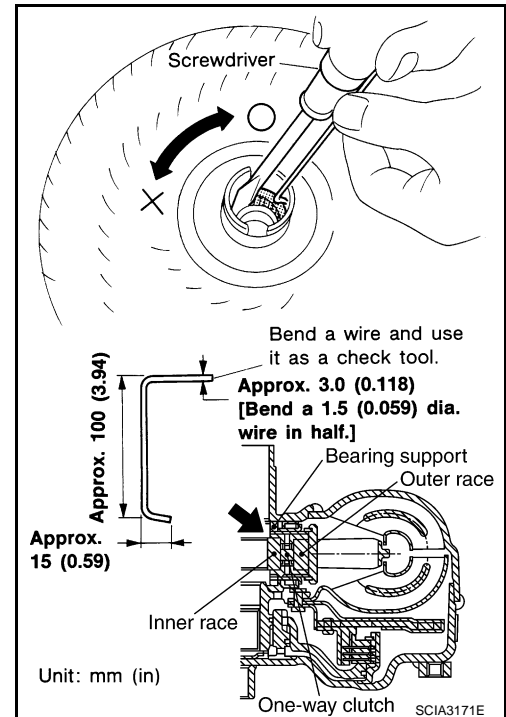

4. Remove tightening bolts (1) for converter housing and transmission case.
  - ◀ : Bolt (8)
  - Self-sealing bolts (2)
5. Remove converter housing from transmission case.

#### CAUTION:

Be careful not to scratch converter housing.

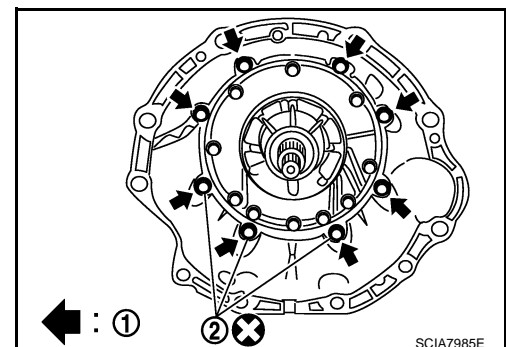

A  
B  
AT  
D  
E  
F  
G  
H  
I  
J  
K  
L  
M  
N  
O  
P

# DISASSEMBLY

## < SERVICE INFORMATION >

6. Remove O-ring from input clutch assembly.

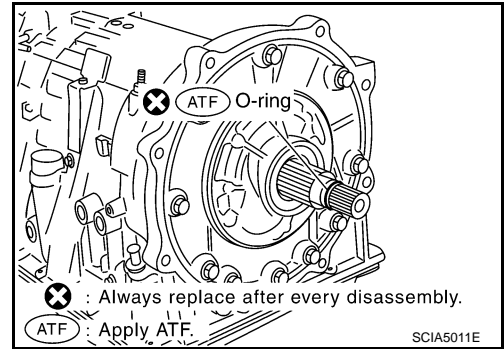

7. Remove tightening bolts for oil pump assembly and transmission case.

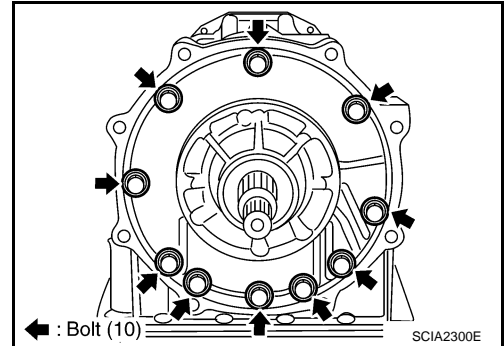

8. Attach the sliding hammers to oil pump assembly and extract it evenly from transmission case.

**CAUTION:**

- Fully tighten sliding hammer screw.
- Make sure that bearing race is installed to the oil pump assembly edge surface.

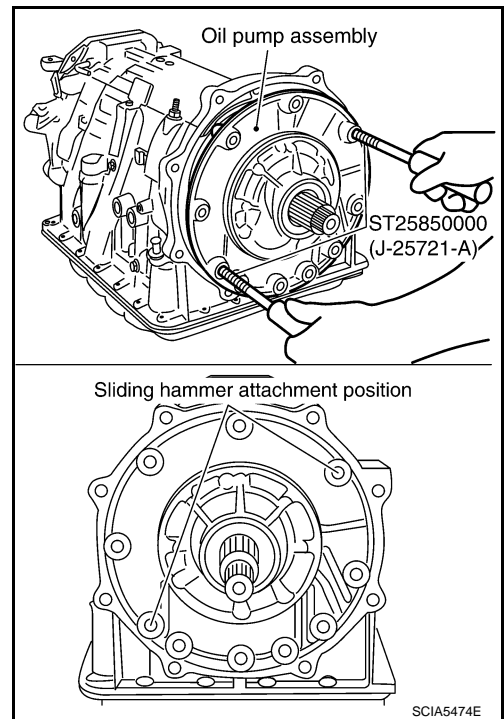

9. Remove O-ring from oil pump assembly.

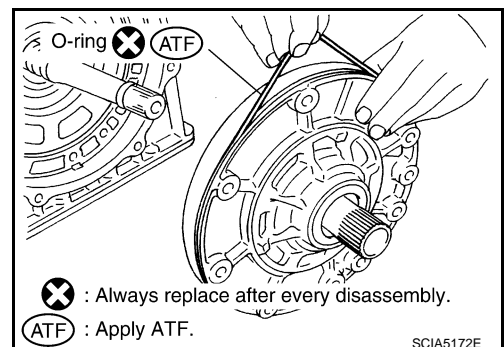

# DISASSEMBLY

## < SERVICE INFORMATION >

10. Remove bearing race from oil pump assembly.

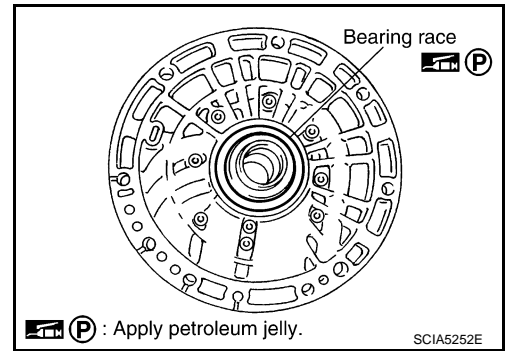

11. Remove needle bearing from front sun gear.

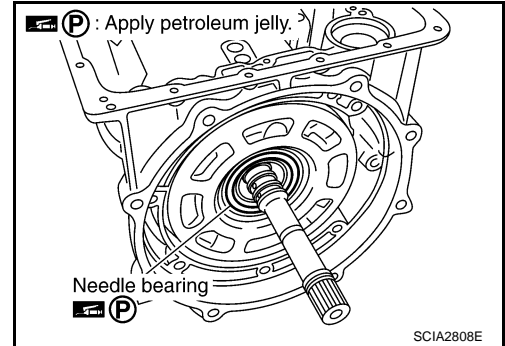

12. Remove front sun gear assembly from front carrier assembly.

**NOTE:**

Remove front sun gear by rotating left/right.

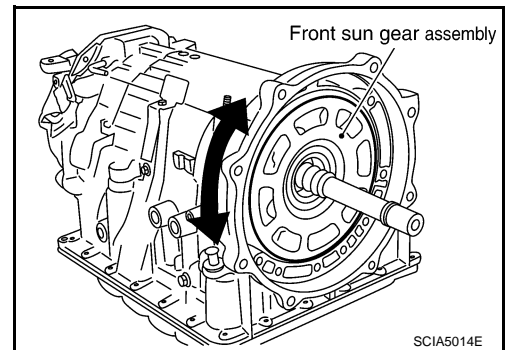

13. Remove seal rings from input clutch assembly.

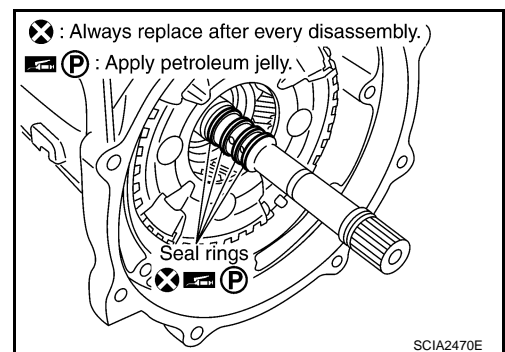

14. Remove front carrier assembly from rear carrier assembly. (With input clutch assembly and rear internal gear.)

**CAUTION:**

Be careful to remove it with needle bearing.

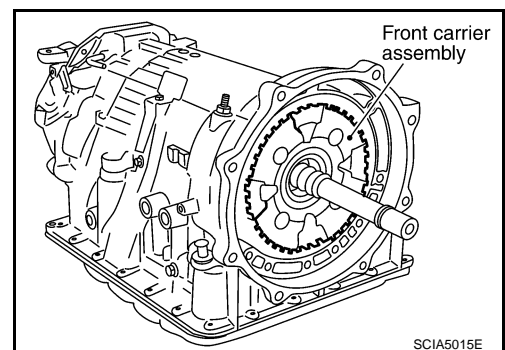

A  
B  
AT  
D  
E  
F  
G  
H  
I  
J  
K  
L  
M  
N  
O  
P

# DISASSEMBLY

## < SERVICE INFORMATION >

15. Loosen lock nut and remove band servo anchor end pin from transmission case.

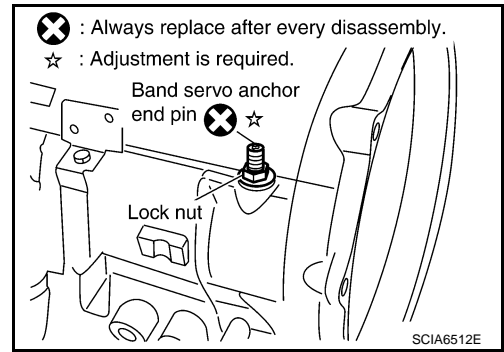

16. Remove brake band from transmission case.

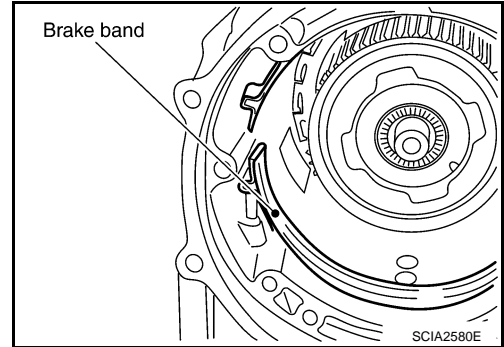

- To prevent brake linings from cracking or peeling, do not stretch the flexible band unnecessarily. When removing the brake band, always secure it with a clip as shown in the figure at right. Leave the clip in position after removing the brake band.
- Check brake band facing for damage, cracks, wear or burns.

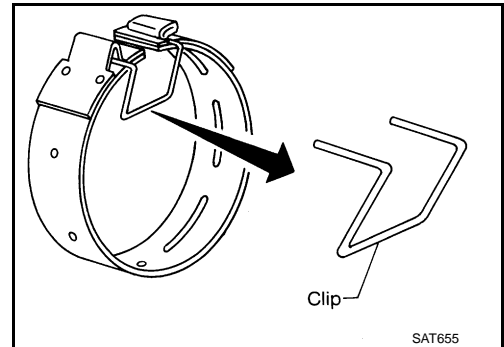

17. Remove mid carrier assembly and rear carrier assembly as a unit.

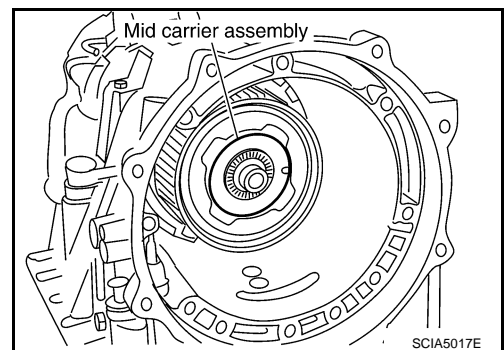

18. Remove mid carrier assembly from rear carrier assembly.

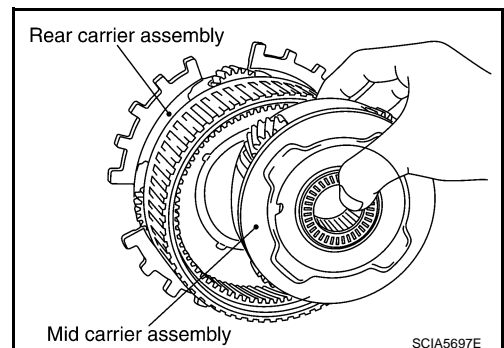

# DISASSEMBLY

## < SERVICE INFORMATION >

19. Remove needle bearing (front side) from mid carrier assembly.

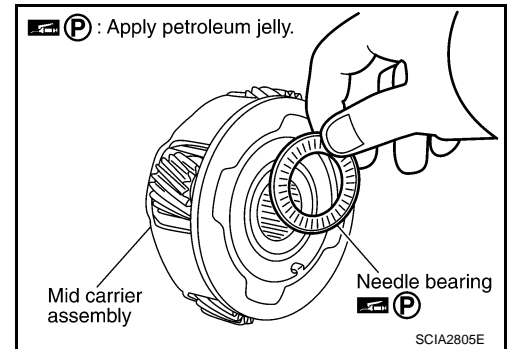

20. Remove needle bearing (rear side) from mid carrier assembly.

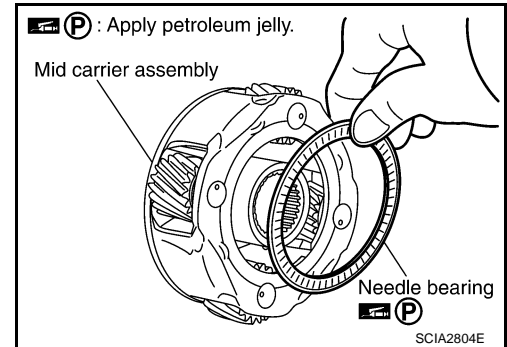

21. Remove bearing race from rear carrier assembly.

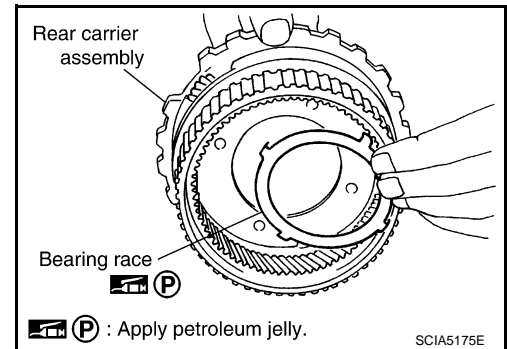

22. Remove needle bearing from rear carrier assembly.

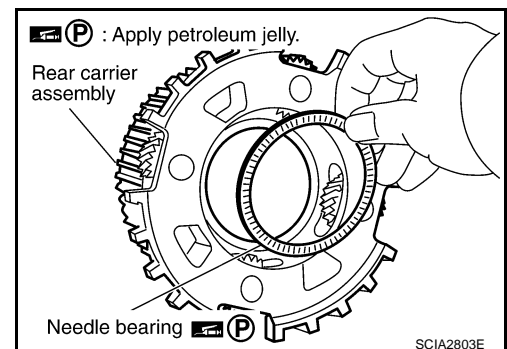

23. Remove mid sun gear assembly, rear sun gear assembly and high and low reverse clutch hub as a unit.

**CAUTION:**

**Be careful to remove them with bearing race and needle bearing.**

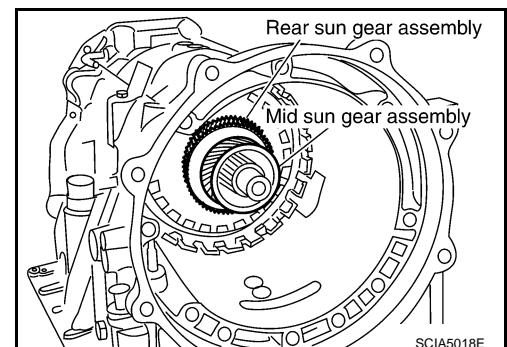

A  
B  
AT  
D  
E  
F  
G  
H  
I  
J  
K  
L  
M  
N  
O  
P

# DISASSEMBLY

## < SERVICE INFORMATION >

24. Remove high and low reverse clutch assembly from direct clutch assembly.

**CAUTION:**

Make sure that needle bearing is installed to the high and low reverse clutch assembly edge surface.

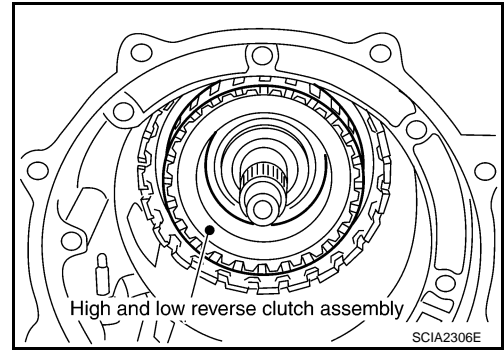

25. Remove direct clutch assembly from reverse brake.

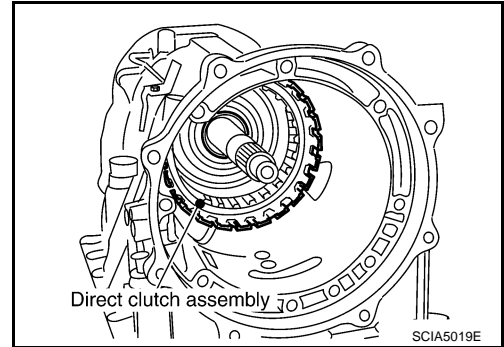

26. Remove needle bearing from drum support.

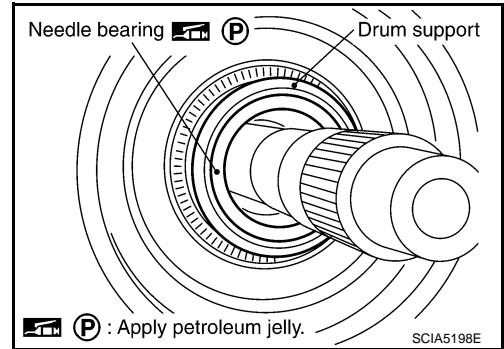

27. Remove snap ring from A/T assembly harness connector.

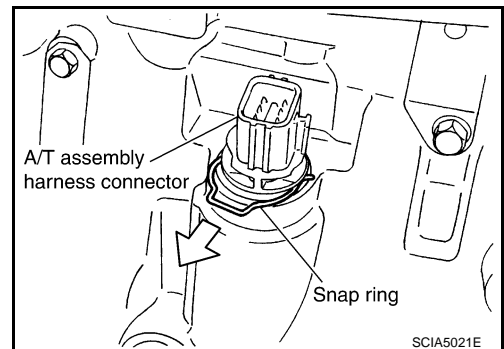

28. Push A/T assembly harness connector.

**CAUTION:**

Be careful not to damage connector.

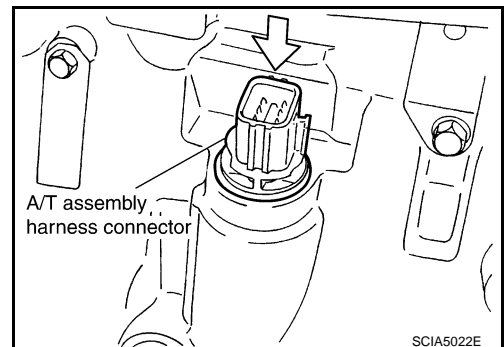



# DISASSEMBLY

## < SERVICE INFORMATION >

29. Remove bracket (1) (VK45DE), clips (2), oil pan (3) and oil pan gasket.

- ⇐: Vehicle front
- ⬅: Bolt (22)
- Drain plug (4)

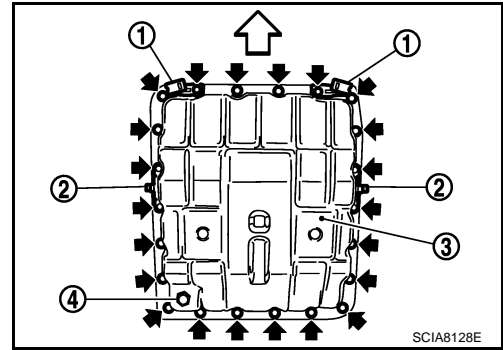

30. Check foreign materials in oil pan to help determine causes of malfunction. If the ATF is very dark, smells burned, or contains foreign particles, the frictional material (clutches, band) may need replacement. A tacky film that will not wipe clean indicates varnish build up. Varnish can cause valves, servo, and clutches to stick and can inhibit pump pressure.

- **If frictional material is detected, perform A/T fluid cooler cleaning. Refer to [AT-13, "A/T Fluid Cooler Cleaning"](#).**

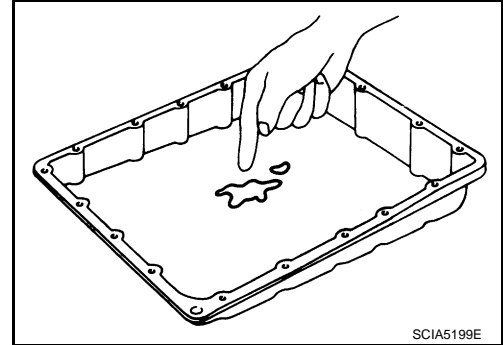

31. Remove magnets from oil pan.

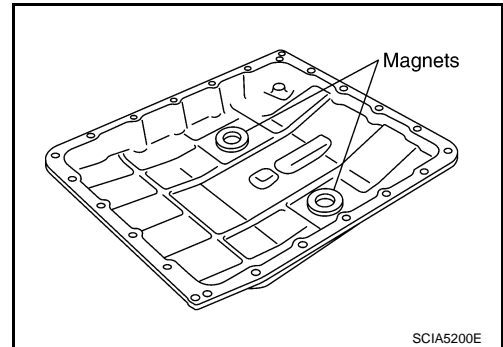

32. Disconnect A/T fluid temperature sensor 2 connector (1).

- **CAUTION:**  
Be careful not to damage connector.

33. Straighten terminal clips (⬅) to free terminal cord assembly and A/T fluid temperature sensor 2 harness.

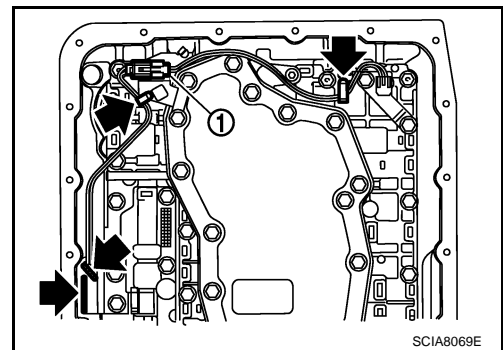

34. Disconnect revolution sensor connector.

- **CAUTION:**  
Be careful not to damage connector.

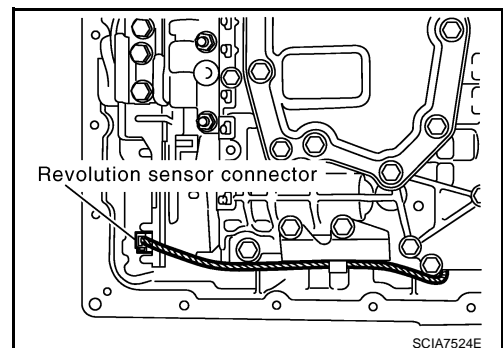

A  
B  
AT  
D  
E  
F  
G  
H  
I  
J  
K  
L  
M  
N  
O  
P

# DISASSEMBLY

## < SERVICE INFORMATION >

35. Straighten terminal clip to free revolution sensor harness.

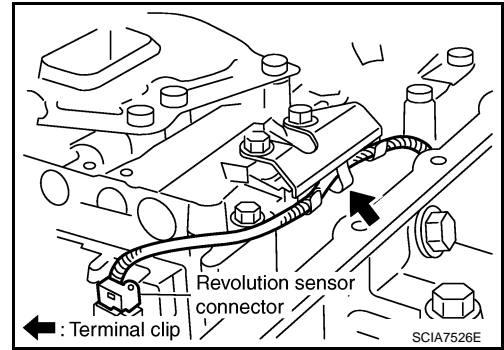

36. Remove bolts A, B and C from control valve with TCM.

• ← : Front

Bolt symbol	Length mm (in)	Number of bolts
A	42 (1.65)	5
B	55 (2.17)	6
C	40 (1.57)	1

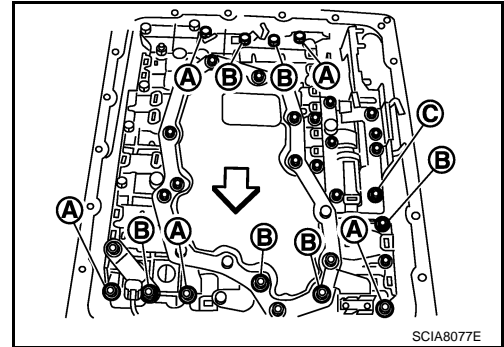

37. Remove control valve with TCM from transmission case.

**CAUTION:**

When removing, be careful with the manual valve notch and manual plate height. Remove it vertically.

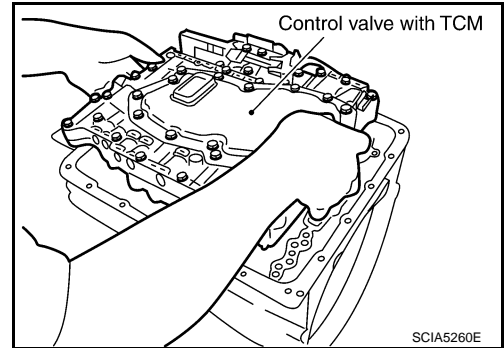

38. Remove A/T fluid temperature sensor 2 with bracket from control valve with TCM.

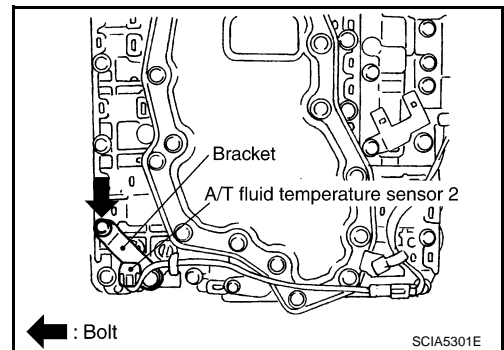

39. Remove bracket from A/T fluid temperature sensor 2.

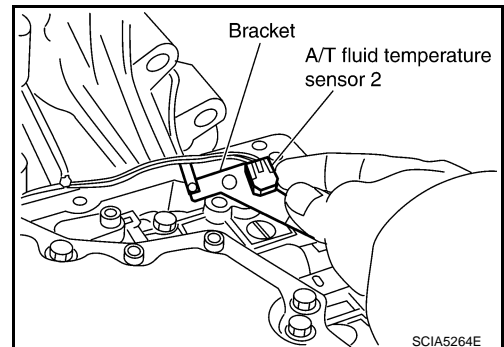

# DISASSEMBLY

## < SERVICE INFORMATION >

40. Remove O-ring from A/T assembly harness connector.

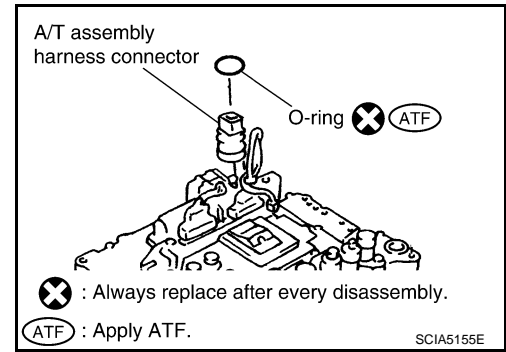

41. Disconnect TCM connectors.

**CAUTION:**  
Be careful not to damage connectors.

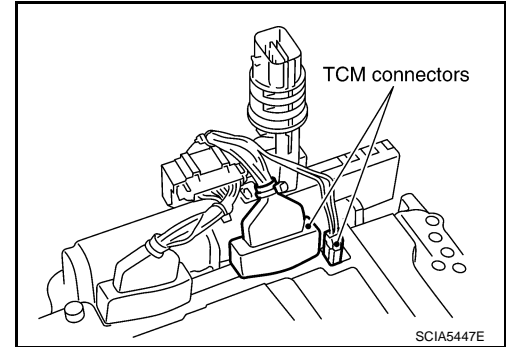

42. Remove A/T assembly harness connector from control valve with TCM using a flat-bladed screwdriver.

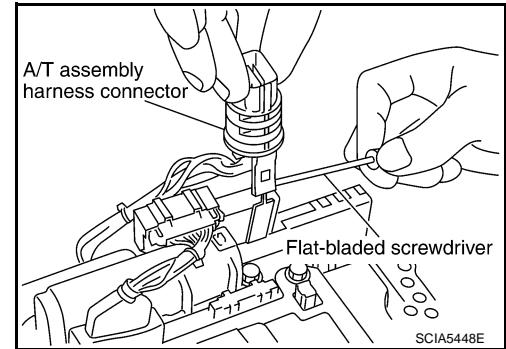

43. Disconnect TCM connector and park/neutral position switch connector.

**CAUTION:**  
Be careful not to damage connectors.

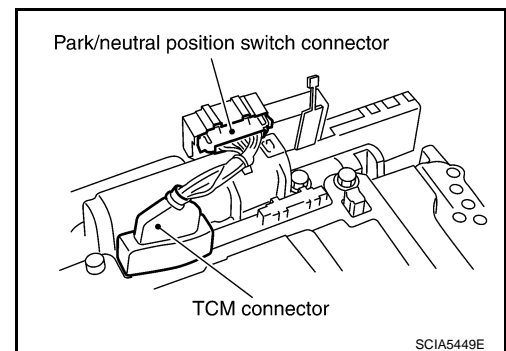

44. Remove rear extension assembly (2WD models) or adapter case assembly (AWD models) according to the following procedures.

a. **2WD models**

# DISASSEMBLY

## < SERVICE INFORMATION >

- i. Remove tightening bolts for rear extension assembly and transmission case.

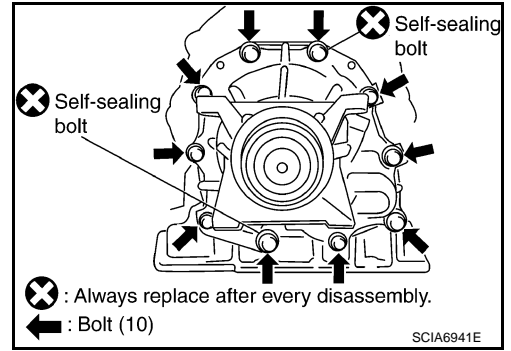

- ii. Tap rear extension assembly with soft hammer.

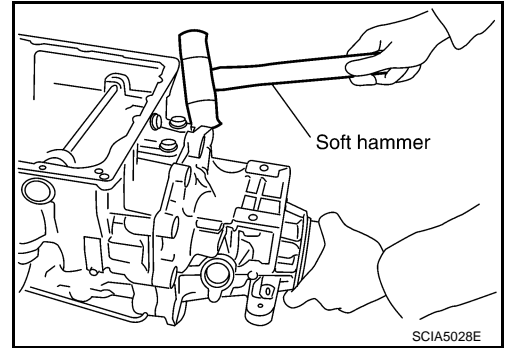

- iii. Remove rear extension assembly from transmission case. (With needle bearing.)

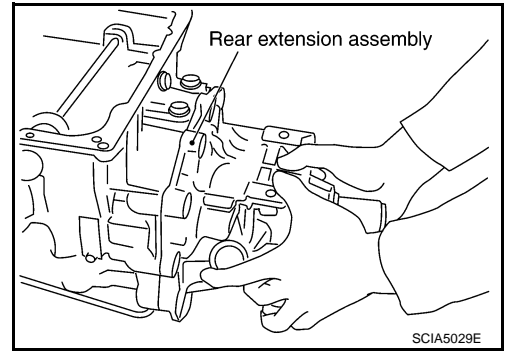

### b. AWD models

- i. Remove tightening bolts (1) for adapter case assembly and transmission case. [With bracket (2).]

- ← : Bolt (10)
- Self-sealing bolts (3)

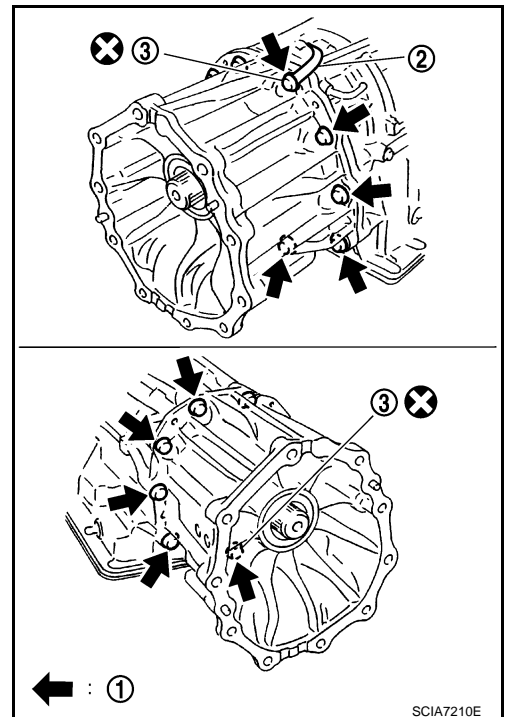

# DISASSEMBLY

## < SERVICE INFORMATION >

ii. Tap adapter case assembly with soft hammer.

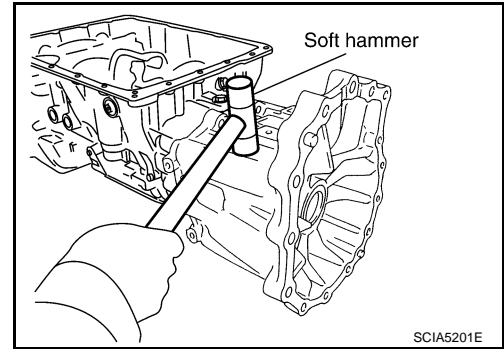

iii. Remove adapter case assembly from transmission case. (With needle bearing)

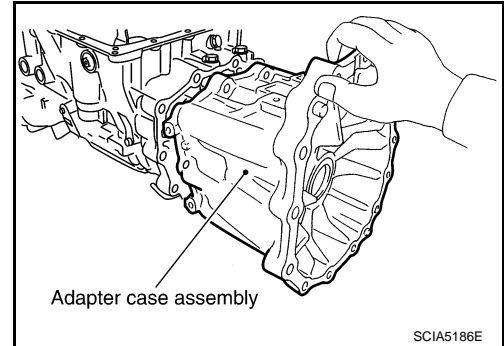

iv. Remove gasket from transmission case.

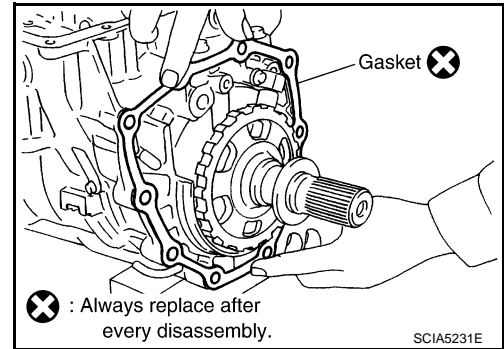

45. Remove bearing race from output shaft.

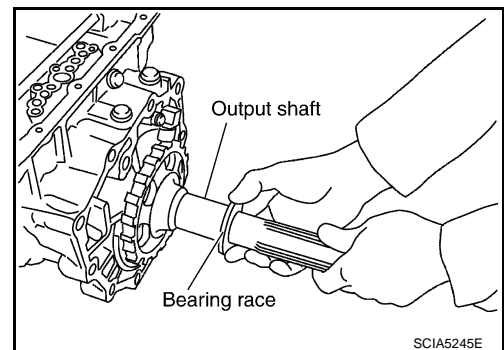

46. Remove output shaft from transmission case by rotating left/right.

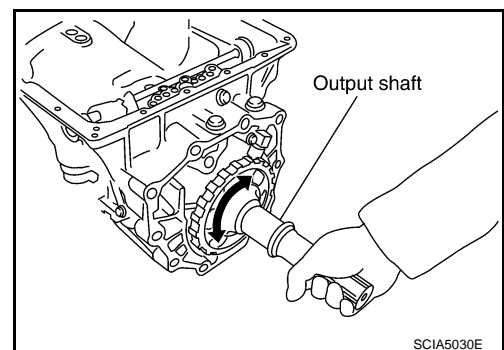

# DISASSEMBLY

## < SERVICE INFORMATION >

47. Remove parking gear from output shaft.

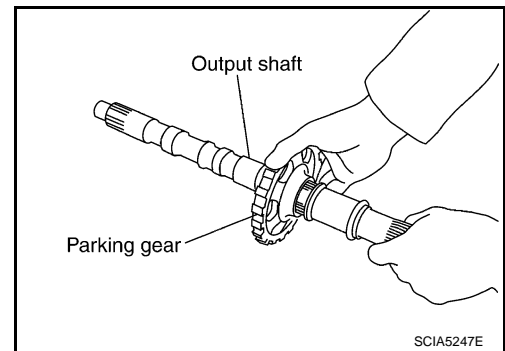

48. Remove seal rings from output shaft.

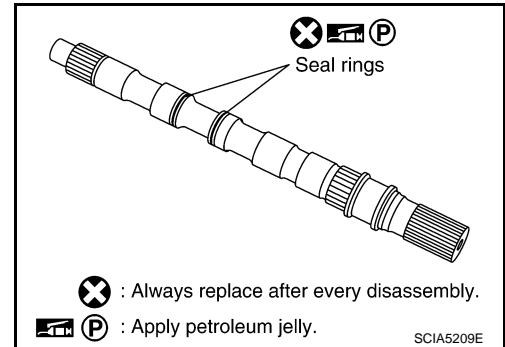

49. Remove needle bearing from transmission case.

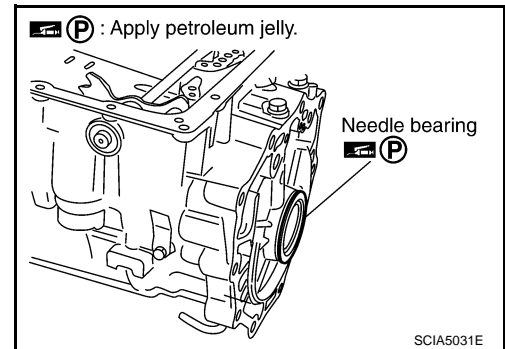

50. Remove revolution sensor from transmission case.

**CAUTION:**

- Do not subject it to impact by dropping or hitting it.
- Do not disassemble.
- Do not allow metal filings, etc. to get on the sensor's front edge magnetic area.
- Do not place in an area affected by magnetism.

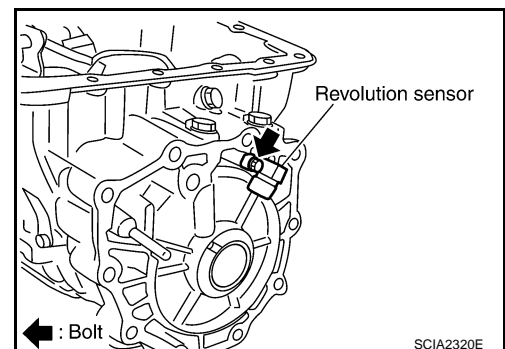

51. Remove reverse brake snap ring (fixing plate) using 2 flat-bladed screwdrivers.

**NOTE:**

Press out snap ring from the transmission case oil pan side gap using a flat-bladed screwdriver, and remove it using another screwdriver.

52. Remove reverse brake retaining plate from transmission case.

- Check facing for burns, cracks or damage. If necessary, replace the plate.

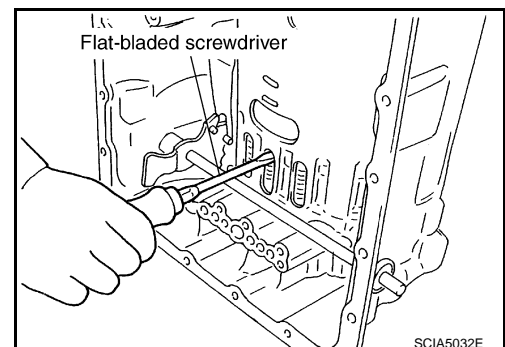

# DISASSEMBLY

## < SERVICE INFORMATION >

53. Remove N-spring from transmission case.

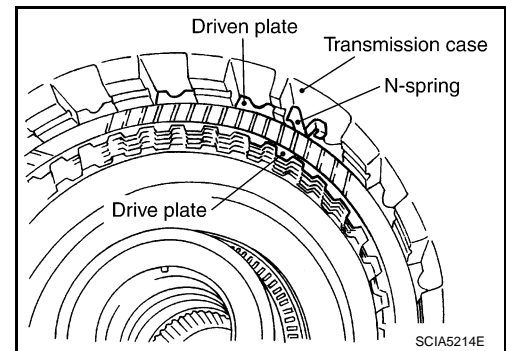

54. Remove reverse brake drive plates, driven plates and dish plate from transmission case.

- Check facing for burns, cracks or damage. If necessary, replace the plate.

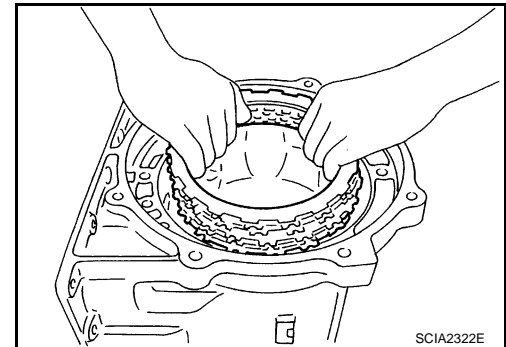

55. Remove snap ring (fixing spring retainer) using a flat-bladed screwdriver.

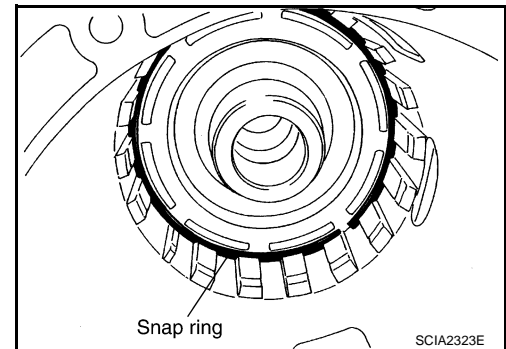

56. Remove spring retainer and return spring from transmission case.

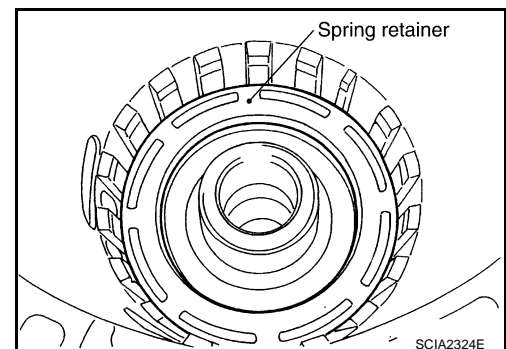

57. Remove seal rings from drum support.

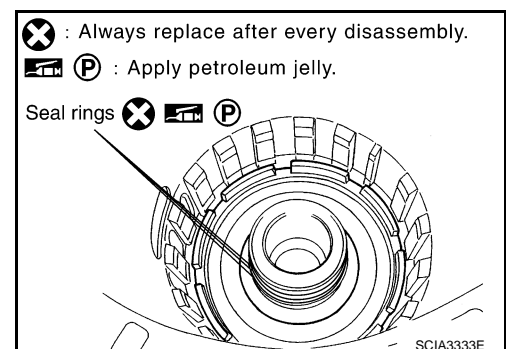

A  
B  
AT  
D  
E  
F  
G  
H  
I  
J  
K  
L  
M  
N  
O  
P

# DISASSEMBLY

## < SERVICE INFORMATION >

58. Remove needle bearing from drum support edge surface.

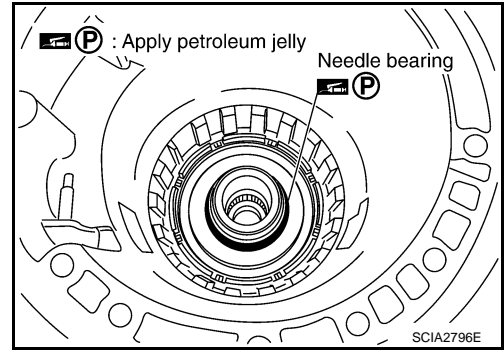

59. Remove reverse brake piston from transmission case with compressed air. Refer to [AT-261, "Oil Channel"](#).

**CAUTION:**

Care should be taken not to abruptly blow air. It makes pistons incline, as the result, it becomes hard to disassemble the pistons.

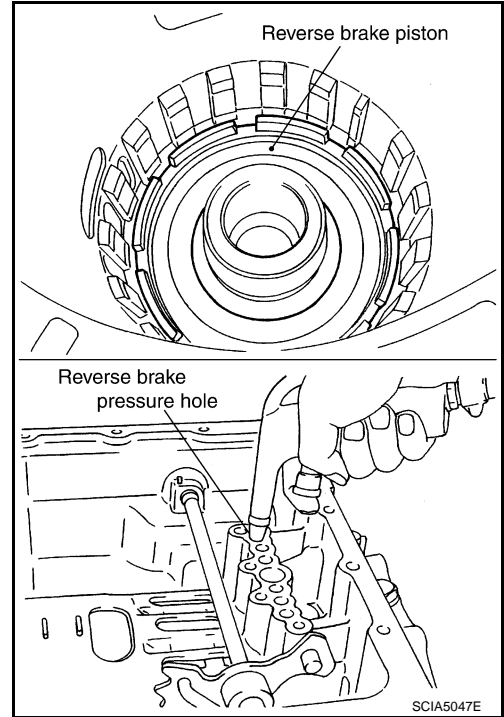

60. Remove D-rings from reverse brake piston.

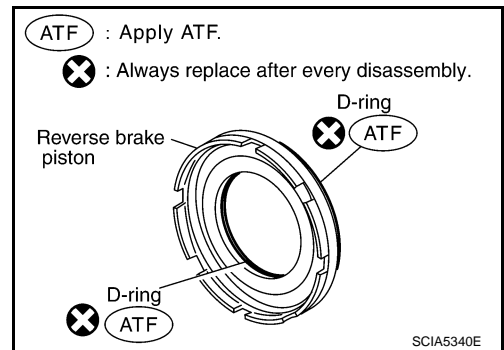

61. Use a pin punch [4 mm (0.16 in) dia. commercial service tool] to knock out retaining pin.

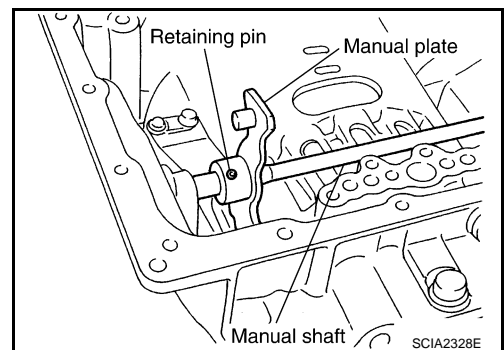



# DISASSEMBLY

## < SERVICE INFORMATION >

62. Remove manual shaft retaining pin with pair of nippers.

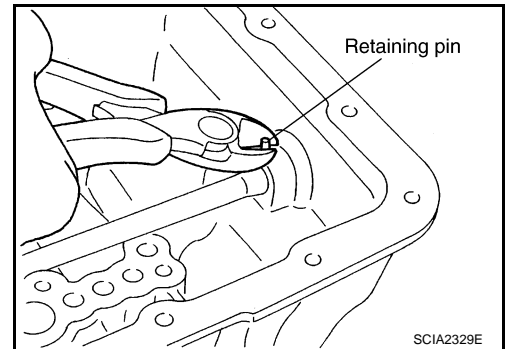

63. Remove manual plate (with parking rod) from manual shaft.

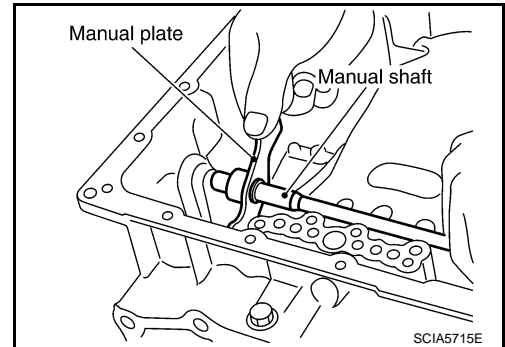

64. Remove parking rod from manual plate.

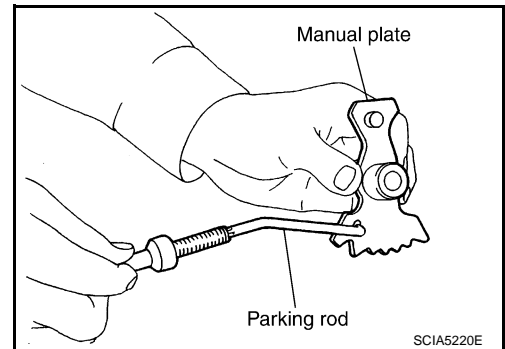

65. Remove manual shaft from transmission case.

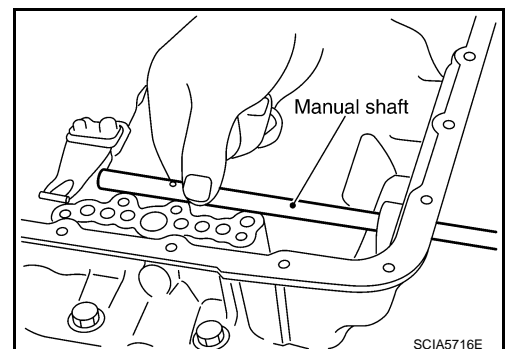

66. Remove manual shaft oil seals using a flat-bladed screwdriver.  
**CAUTION:**  
Be careful not to scratch transmission case.

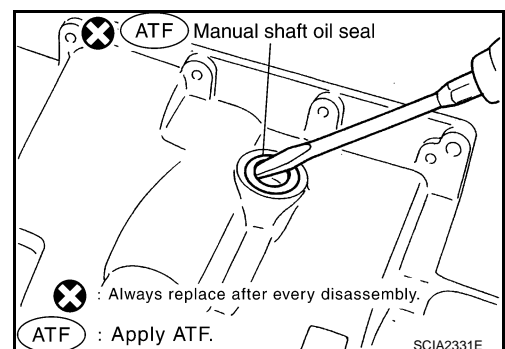

A  
B  
AT  
D  
E  
F  
G  
H  
I  
J  
K  
L  
M  
N  
O  
P

# DISASSEMBLY

## < SERVICE INFORMATION >

67. Remove detent spring and spacer from transmission case.

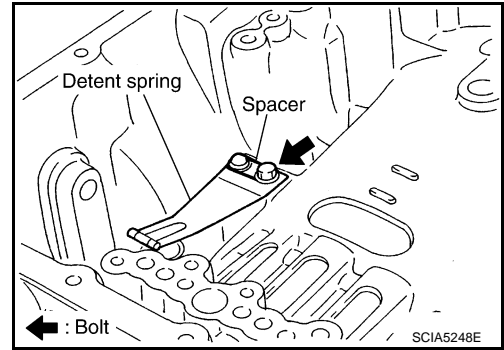

68. Using pair of snap ring pliers, remove snap ring from transmission case.

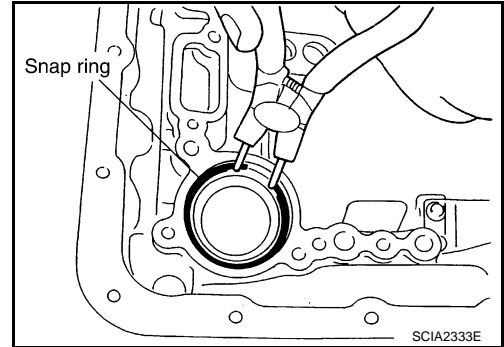

69. Remove servo assembly (with return spring) from transmission case.

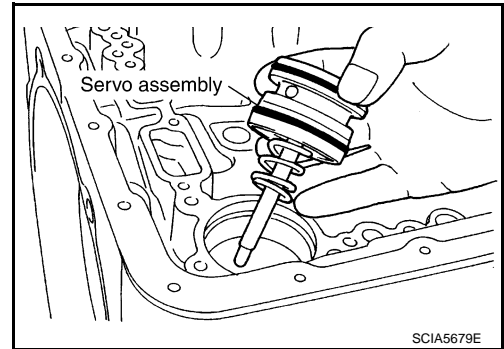

70. Remove return spring from servo assembly.

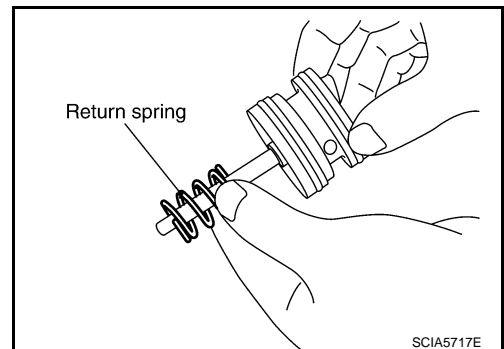

71. Remove O-rings from servo assembly.

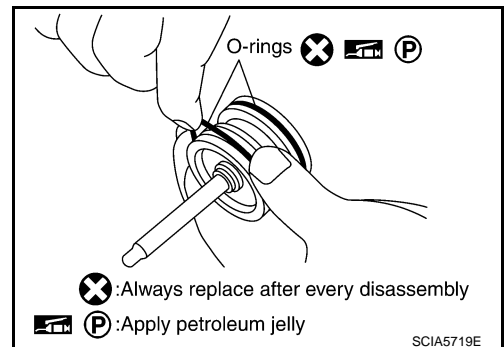

# DISASSEMBLY

## < SERVICE INFORMATION >

72. Remove needle bearing from rear extension (2WD models) or adapter case (AWD models).

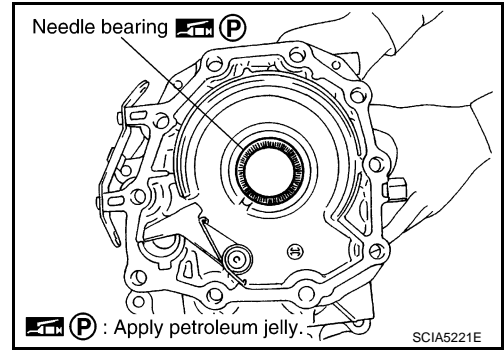

73. Remove parking actuator support from rear extension (2WD models) or adapter case (AWD models).

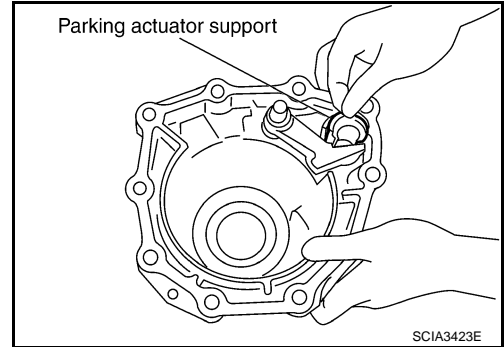

74. Remove parking pawl (with return spring) and pawl shaft from rear extension (2WD models) or adapter case (AWD models).

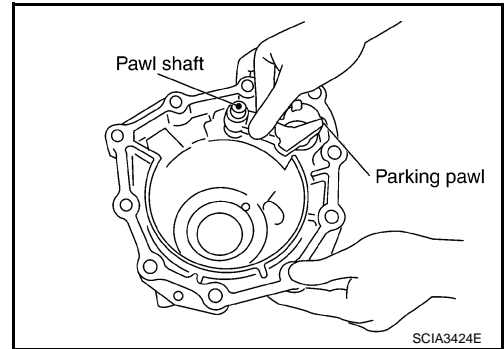

75. Remove return spring from parking pawl.  
• VQ35DE models

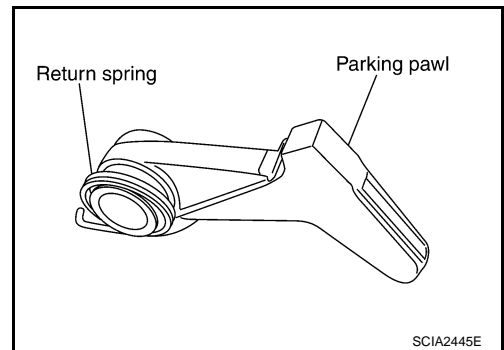

A  
B  
AT  
D  
E  
F  
G  
H  
I  
J  
K  
L  
M  
N  
O  
P

# DISASSEMBLY

## < SERVICE INFORMATION >

- **VK45DE models**
  - Return spring (1)
  - Parking pawl (2)

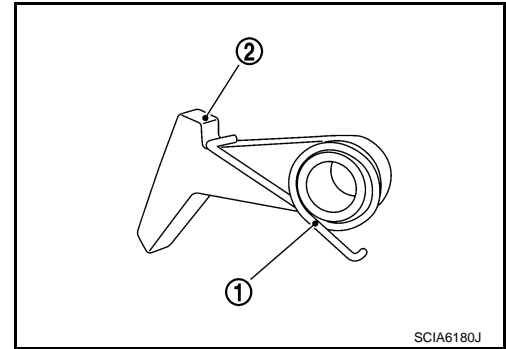

76. Remove rear oil seal from rear extension (2WD models) or adapter case (AWD models).

**CAUTION:**

**Be careful not to scratch rear extension (2WD models) or adapter case (AWD models).**

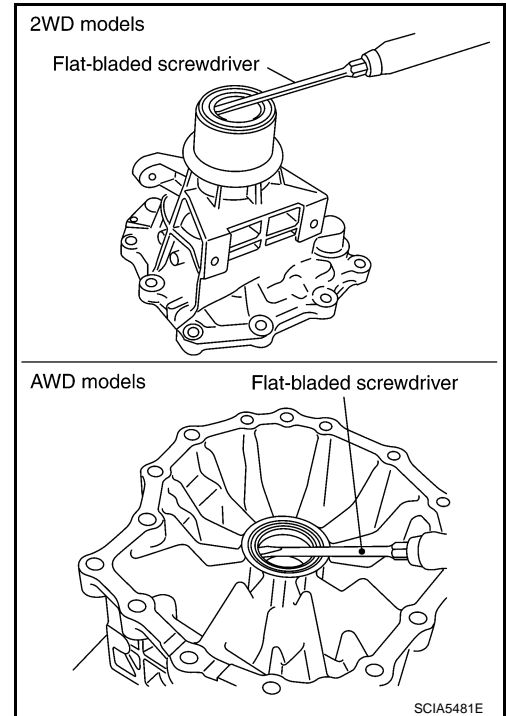

# REPAIR FOR COMPONENT PARTS

< SERVICE INFORMATION >

## REPAIR FOR COMPONENT PARTS

### Oil Pump

INFOID:000000001327404

### COMPONENTS

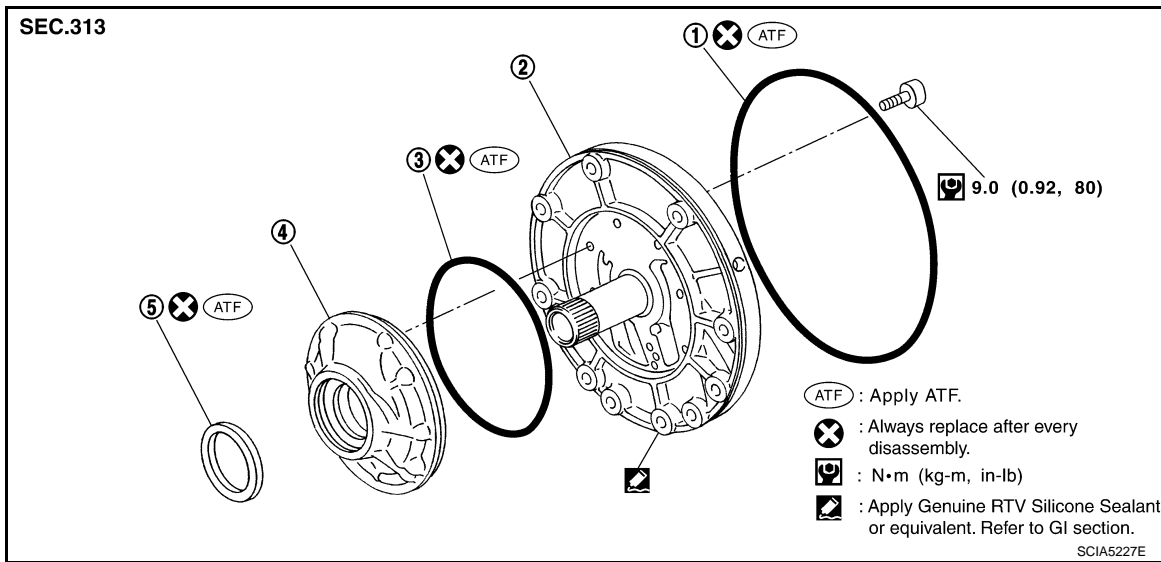

- |                     |                              |           |
|---------------------|------------------------------|-----------|
| 1. O-ring           | 2. Oil pump cover            | 3. O-ring |
| 4. Oil pump housing | 5. Oil pump housing oil seal |           |

### DISASSEMBLY

- Remove oil pump housing from oil pump cover.

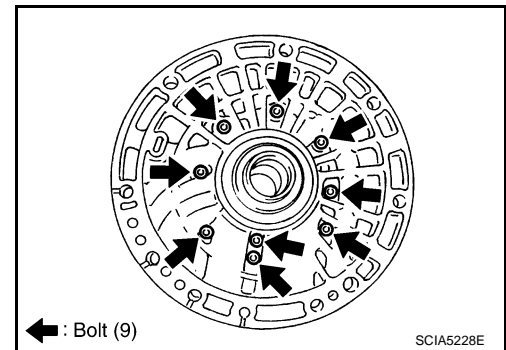

- Remove oil pump housing oil seal using a flat-bladed screwdriver.

**CAUTION:**

**Be careful not to scratch oil pump housing.**

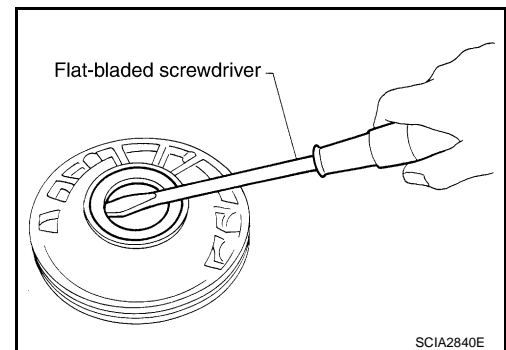

A  
B  
AT  
D  
E  
F  
G  
H  
I  
J  
K  
L  
M  
N  
O  
P

# REPAIR FOR COMPONENT PARTS

## < SERVICE INFORMATION >

3. Remove O-ring from oil pump housing.

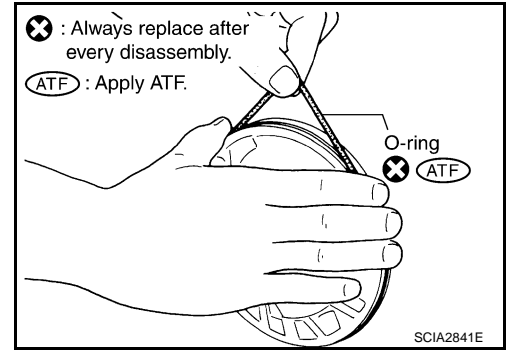

4. Remove O-ring from oil pump cover.

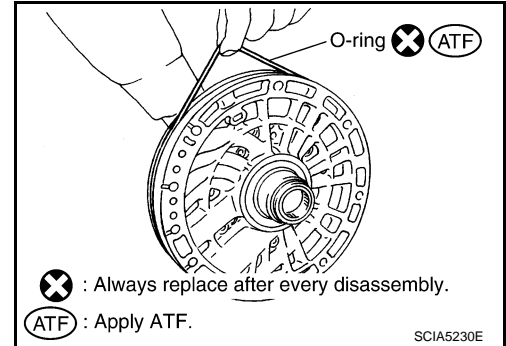

## ASSEMBLY

1. Install O-ring to oil pump cover.

**CAUTION:**

- Do not reuse O-ring.
- Apply ATF to O-ring.

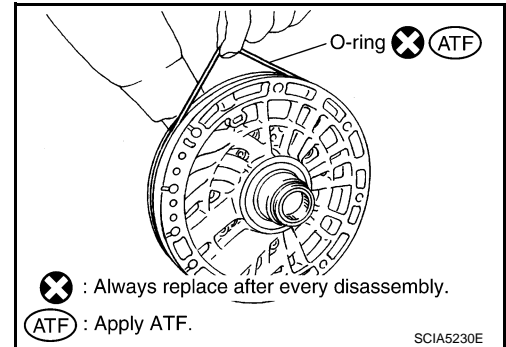

2. Install O-ring to oil pump housing.

**CAUTION:**

- Do not reuse O-ring.
- Apply ATF to O-ring.

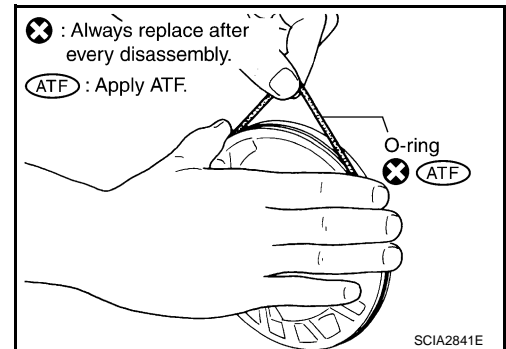

# REPAIR FOR COMPONENT PARTS

## < SERVICE INFORMATION >

- Using the drift, install oil pump housing oil seal to the oil pump housing until it is flush.

**CAUTION:**

- Do not reuse oil pump housing oil seal.
- Apply ATF to oil pump housing oil seal.

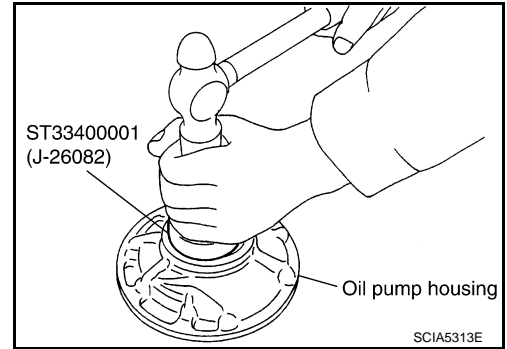

- Install oil pump housing to oil pump cover.
- Tighten bolts to the specified torque in numerical order shown in the figure after temporarily tightening them. Refer to "COMPONENTS".

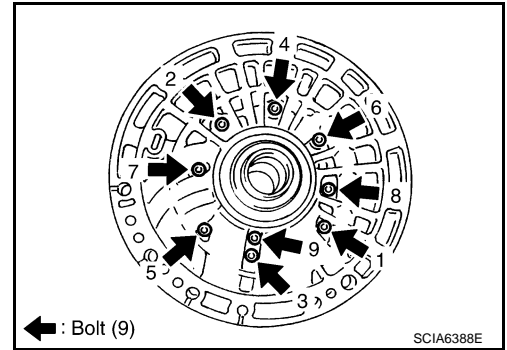

## Front Sun Gear, 3rd One-Way Clutch

INFOID:000000001327405

### COMPONENTS

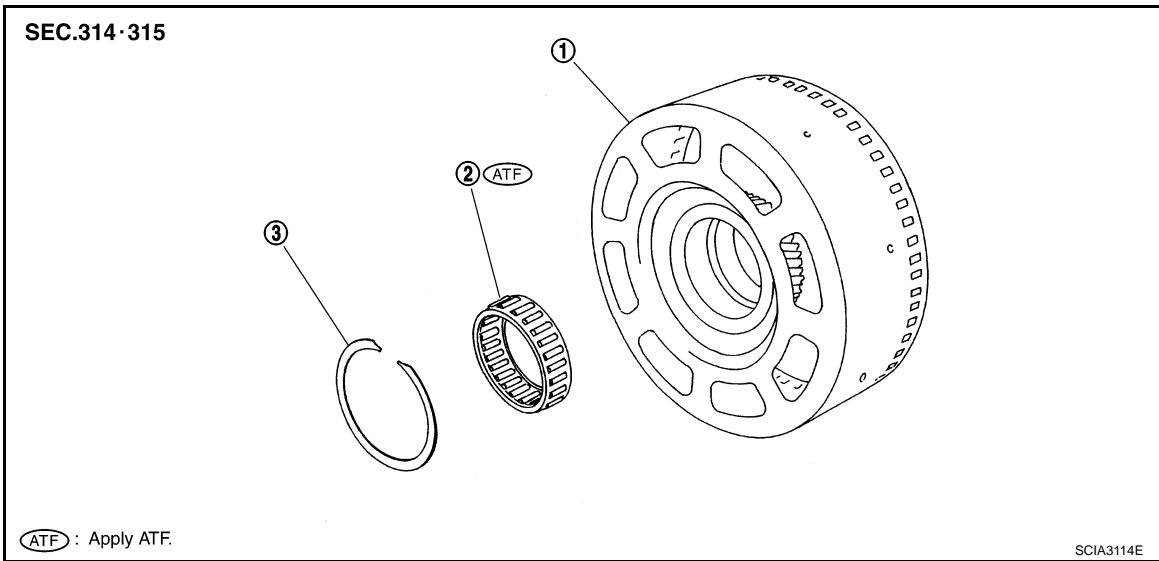

- Front sun gear
- 3rd one-way clutch
- Snap ring

### DISASSEMBLY

A  
B  
AT  
D  
E  
F  
G  
H  
I  
J  
K  
L  
M  
N  
O  
P

## REPAIR FOR COMPONENT PARTS

### < SERVICE INFORMATION >

1. Using a flat-bladed screwdriver, remove snap ring from front sun gear.

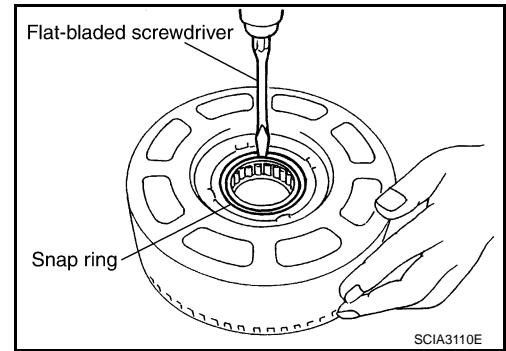

2. Remove 3rd one-way clutch from front sun gear.

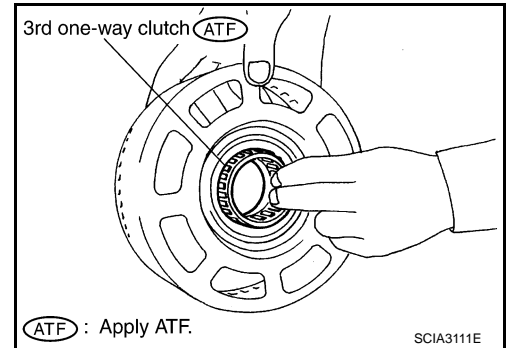

### INSPECTION

#### 3rd One-way Clutch

- Check frictional surface for wear or damage.

**CAUTION:**

**If necessary, replace the 3rd one-way clutch.**

#### Front Sun Gear Snap Ring

- Check for deformation, fatigue or damage.

**CAUTION:**

**If necessary, replace the snap ring.**

#### Front Sun Gear

- Check for deformation, fatigue or damage.

**CAUTION:**

**If necessary, replace the front sun gear.**

### ASSEMBLY

1. Install 3rd one-way clutch in front sun gear.

**CAUTION:**

**Apply ATF to 3rd one-way clutch.**

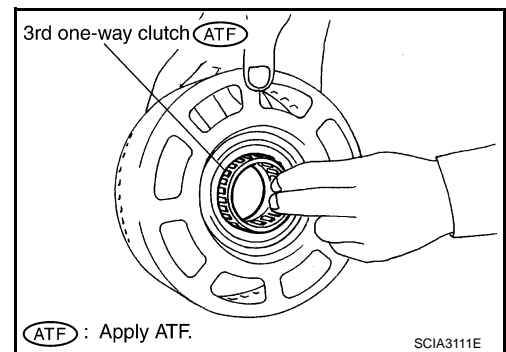



## REPAIR FOR COMPONENT PARTS

### < SERVICE INFORMATION >

2. Using a flat-bladed screwdriver, install snap ring in front sun gear.

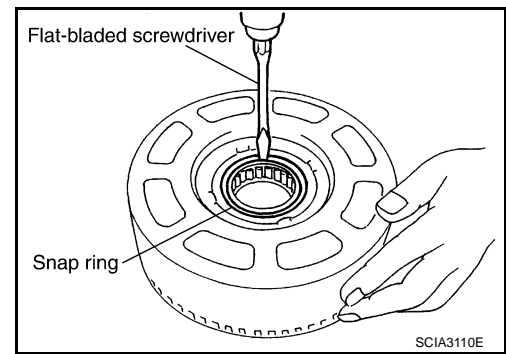

3. Check operation of 3rd one-way clutch.
  - a. Hold oil pump assembly and turn front sun gear.
  - b. Check 3rd one-way clutch for correct locking and unlocking directions.

**CAUTION:**

If not as shown in the figure, check installation direction of 3rd one-way clutch.

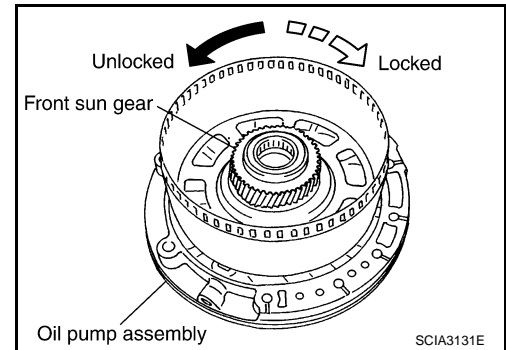

Front Carrier, Input Clutch, Rear Internal Gear

COMPONENTS

INFOID:000000001327406

A  
B  
AT  
D  
E  
F  
G  
H  
I  
J  
K  
L  
M  
N  
O  
P

# REPAIR FOR COMPONENT PARTS

< SERVICE INFORMATION >

VQ35DE models

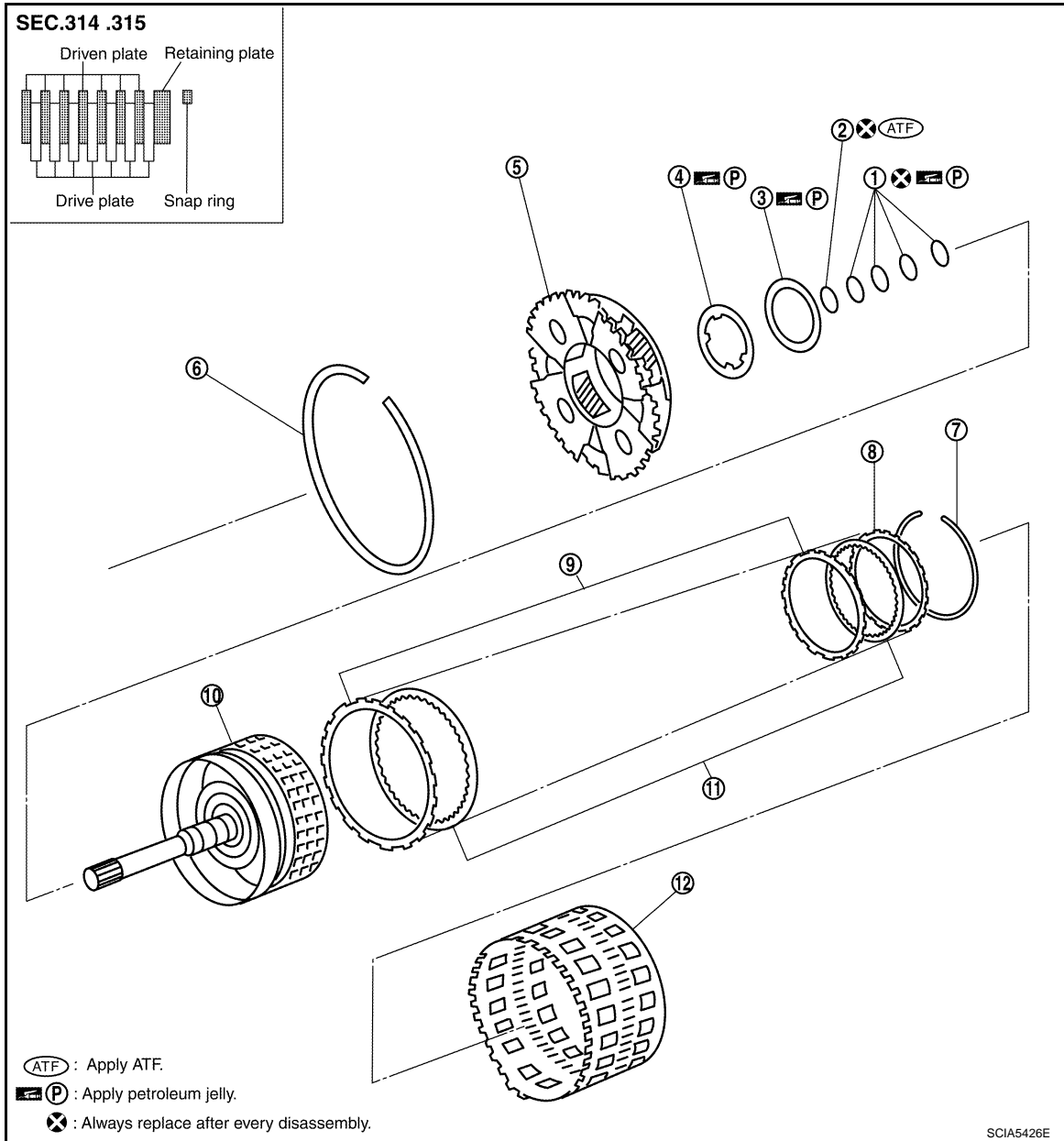

- |                       |                           |                        |
|-----------------------|---------------------------|------------------------|
| 1. Seal ring          | 2. O-ring                 | 3. Needle bearing      |
| 4. Bearing race       | 5. Front carrier assembly | 6. Snap ring           |
| 7. Snap ring          | 8. Retaining plate        | 9. Driven plate        |
| 10. Input clutch drum | 11. Drive plate           | 12. Rear internal gear |

# REPAIR FOR COMPONENT PARTS

< SERVICE INFORMATION >

VK45DE models

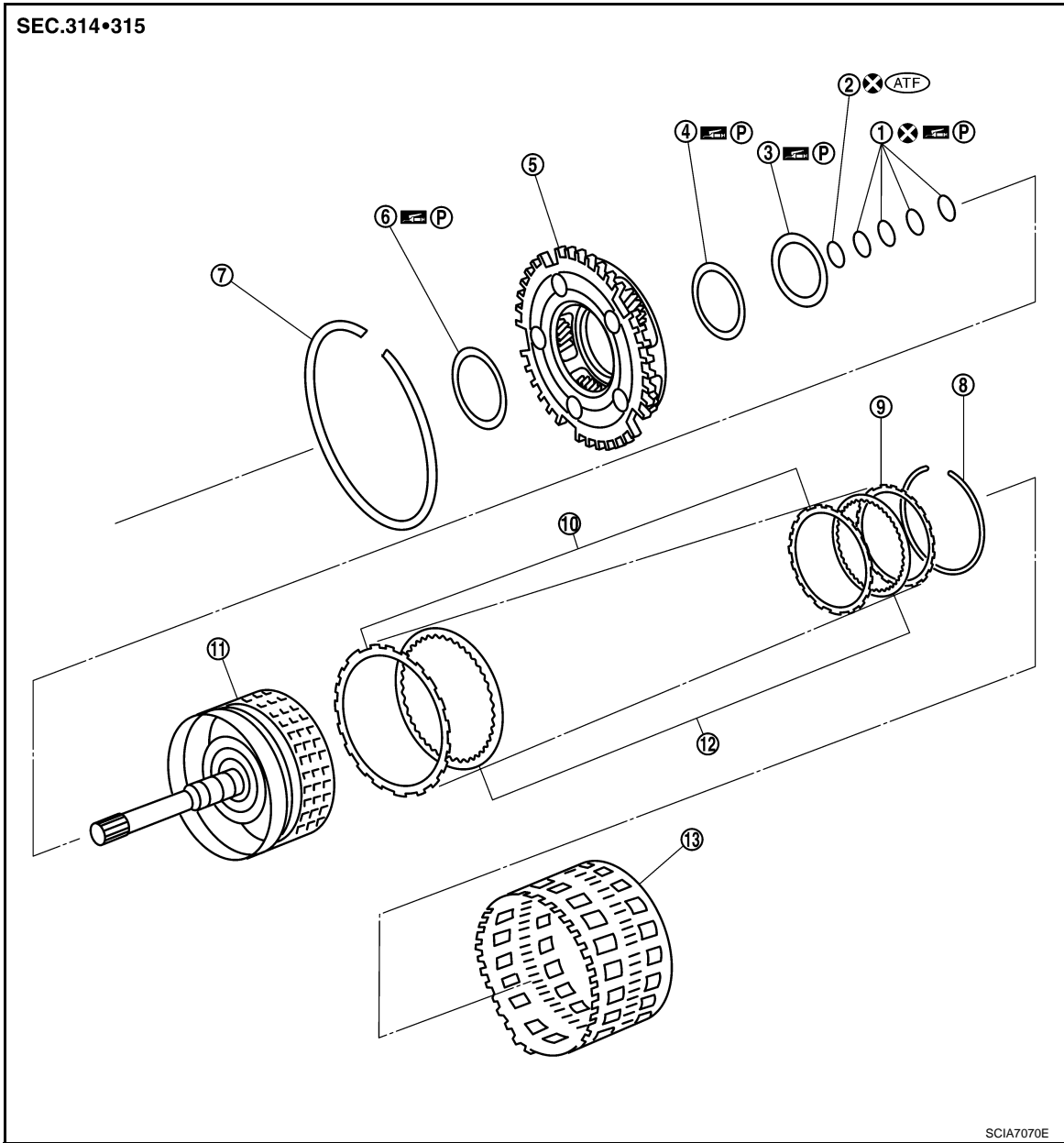

- |                        |                           |                    |
|------------------------|---------------------------|--------------------|
| 1. Seal ring           | 2. O-ring                 | 3. Needle bearing  |
| 4. Bearing race        | 5. Front carrier assembly | 6. Needle bearing  |
| 7. Snap ring           | 8. Snap ring              | 9. Retaining plate |
| 10. Driven plate       | 11. Input clutch drum     | 12. Drive plate    |
| 13. Rear internal gear |                           |                    |

Refer to GI section to make sure icons (symbol marks) in the figure. Refer to [GI-8, "Component"](#).

## DISASSEMBLY

A  
B  
AT  
D  
E  
F  
G  
H  
I  
J  
K  
L  
M  
N  
O  
P

# REPAIR FOR COMPONENT PARTS

## < SERVICE INFORMATION >

1. Compress snap ring using 2 flat-bladed screwdrivers.
2. Remove front carrier assembly and input clutch assembly from rear internal gear.
3. Remove front carrier assembly from input clutch assembly.

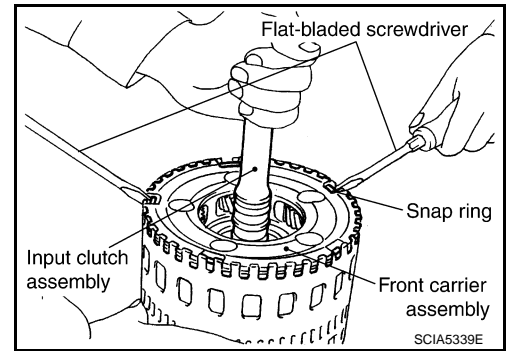

- a. Remove bearing race from front carrier assembly.

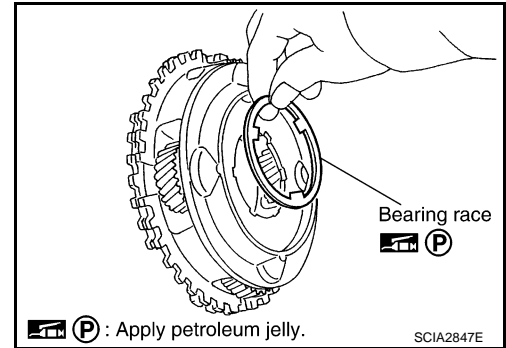

- b. Remove needle bearing from front carrier assembly. (VK45DE models)

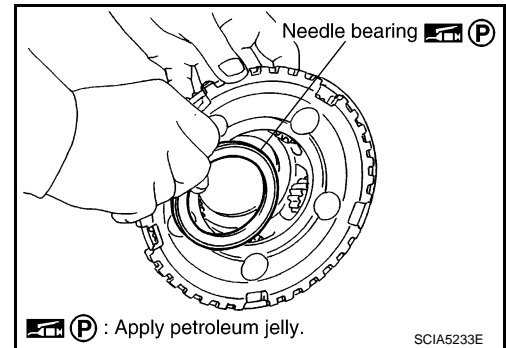

- c. Remove snap ring from front carrier assembly.  
**CAUTION:**  
Do not expand snap ring excessively.

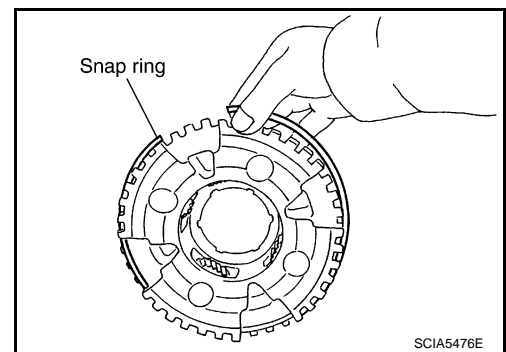

4. Disassemble input clutch assembly.
  - a. Remove O-ring and seal rings from input clutch assembly.

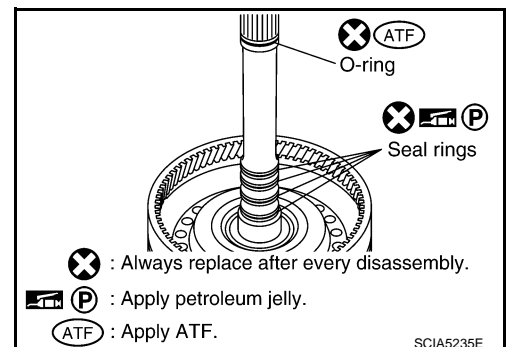

# REPAIR FOR COMPONENT PARTS

## < SERVICE INFORMATION >

b. Remove needle bearing from input clutch assembly.

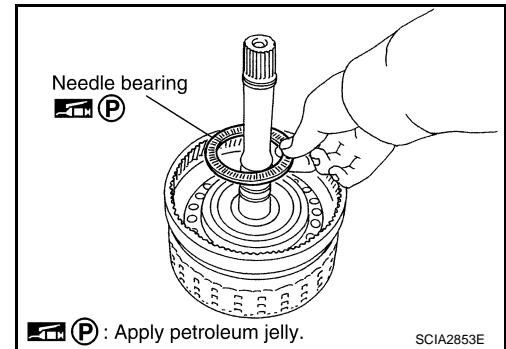

- c. Using a flat-bladed screwdriver, remove snap ring from input clutch drum.
- d. Remove drive plates, driven plates and retaining plate from input clutch drum.

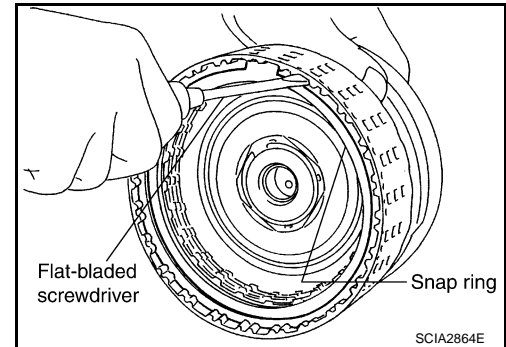

## INSPECTION

### Front Carrier Snap Ring

- Check for deformation, fatigue or damage.

**CAUTION:**

**If necessary, replace the snap ring.**

### Input Clutch Snap Ring

- Check for deformation, fatigue or damage.

**CAUTION:**

**If necessary, replace the input clutch assembly.**

### Input Clutch Drum

- Check for deformation, fatigue or damage or burns.

**CAUTION:**

**If necessary, replace the input clutch assembly.**

### Input Clutch Drive Plates

- Check facing for burns, cracks or damage.

**CAUTION:**

**If necessary, replace the input clutch assembly.**

### Input Clutch Retaining Plates and Driven Plates

- Check facing for burns, cracks or damage.

**CAUTION:**

**If necessary, replace the input clutch assembly.**

### Front Carrier

- Check for deformation, fatigue or damage.

**CAUTION:**

**If necessary, replace the front carrier assembly.**

### Rear Internal Gear

- Check for deformation, fatigue or damage.

**CAUTION:**

**If necessary, replace the rear internal gear assembly.**

## ASSEMBLY

1. Install input clutch.

A  
B  
AT  
D  
E  
F  
G  
H  
I  
J  
K  
L  
M  
N  
O  
P

## REPAIR FOR COMPONENT PARTS

### < SERVICE INFORMATION >

- a. Install drive plates, driven plates and retaining plate in input clutch drum.
- Snap ring (1)
  - Retaining plate (2)
  - Drive plate (3)
  - Driven plate (4)
  - Drive plate/Driven plate: 7/7

**CAUTION:**

Take care with order of plates.

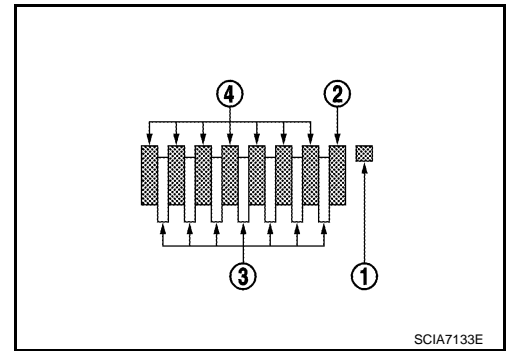

- b. Using a flat-bladed screwdriver, install snap ring in input clutch drum.

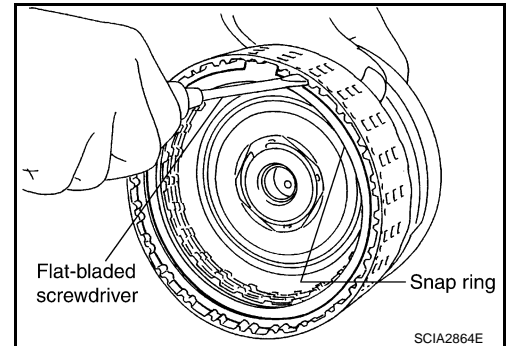

- c. Install needle bearing in input clutch assembly.

**CAUTION:**

- Take care with the direction of needle bearing. Refer [AT-264, "Location of Adjusting Shims, Needle Bearings, Thrust Washers and Snap Rings"](#).
- Apply petroleum jelly to needle bearing.

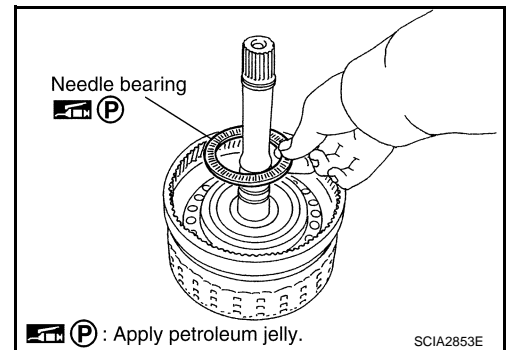

- d. Install O-ring and seal rings in input clutch assembly.

**CAUTION:**

- Do not reuse O-ring and seal rings.
- Apply ATF to O-ring.
- Apply petroleum jelly to seal rings.

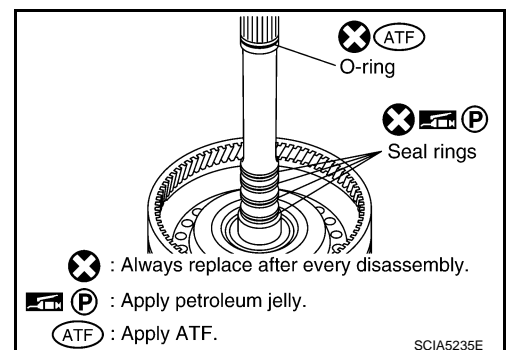

2. Install front carrier assembly.

- a. Install snap ring to front carrier assembly.

**CAUTION:**

Do not expand snap ring excessively.

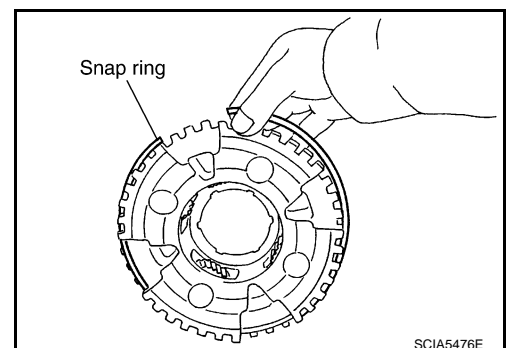

# REPAIR FOR COMPONENT PARTS

## < SERVICE INFORMATION >

b. Install needle bearing in front carrier assembly. (VK45DE models)

**CAUTION:**

- Take care with the direction of needle bearing. Refer to [AT-264, "Location of Adjusting Shims, Needle Bearings, Thrust Washers and Snap Rings"](#).
- Apply petroleum jelly to needle bearing.

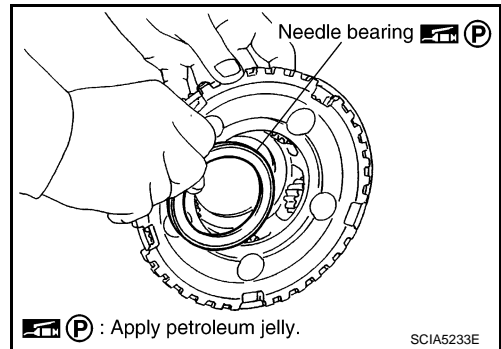

c. Install bearing race in front carrier assembly.

**CAUTION:**

**Apply petroleum jelly to bearing race.**

d. Install front carrier assembly to input clutch assembly.

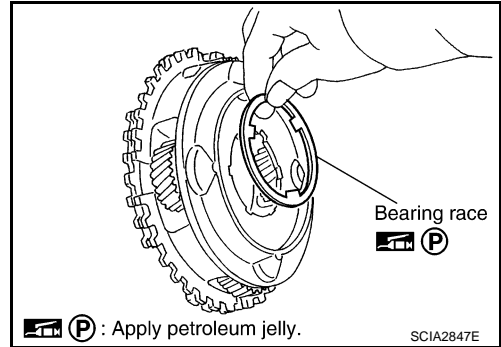

3. Compress snap ring using 2 flat-bladed screwdrivers.

4. Install front carrier assembly and input clutch assembly to rear internal gear.

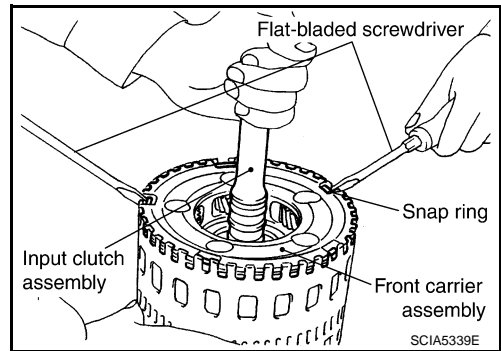

## Mid Sun Gear, Rear Sun Gear, High and Low Reverse Clutch Hub

INFOID:000000001327407

## COMPONENTS

### VQ35DE models

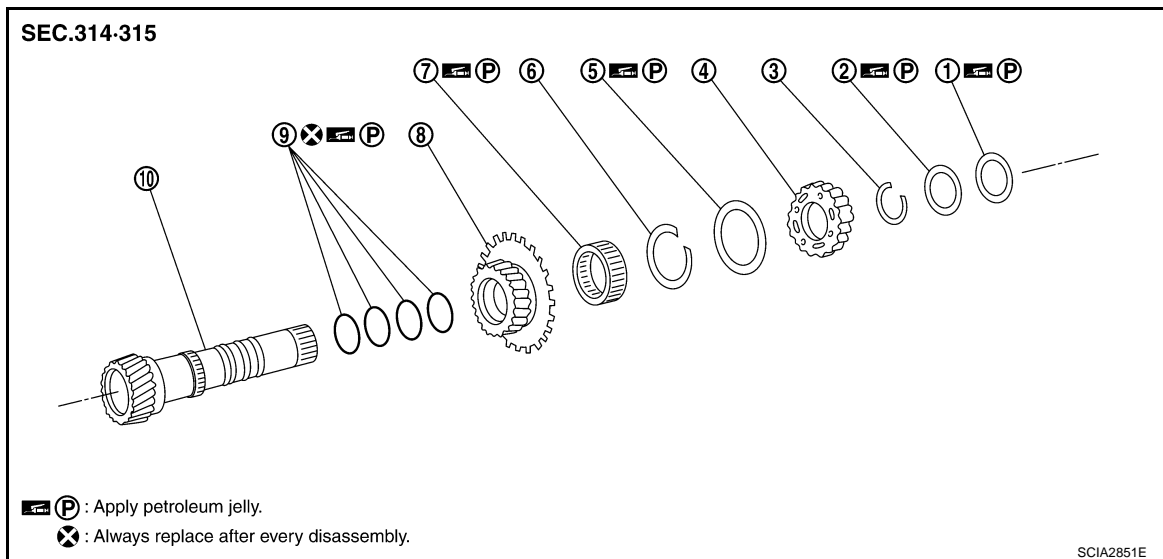

# REPAIR FOR COMPONENT PARTS

## < SERVICE INFORMATION >

- |                                    |                   |              |
|------------------------------------|-------------------|--------------|
| 1. Needle bearing                  | 2. Bearing race   | 3. Snap ring |
| 4. High and low reverse clutch hub | 5. Needle bearing | 6. Snap ring |
| 7. 1st one-way clutch              | 8. Rear sun gear  | 9. Seal ring |
| 10. Mid sun gear                   |                   |              |

### VK45DE models

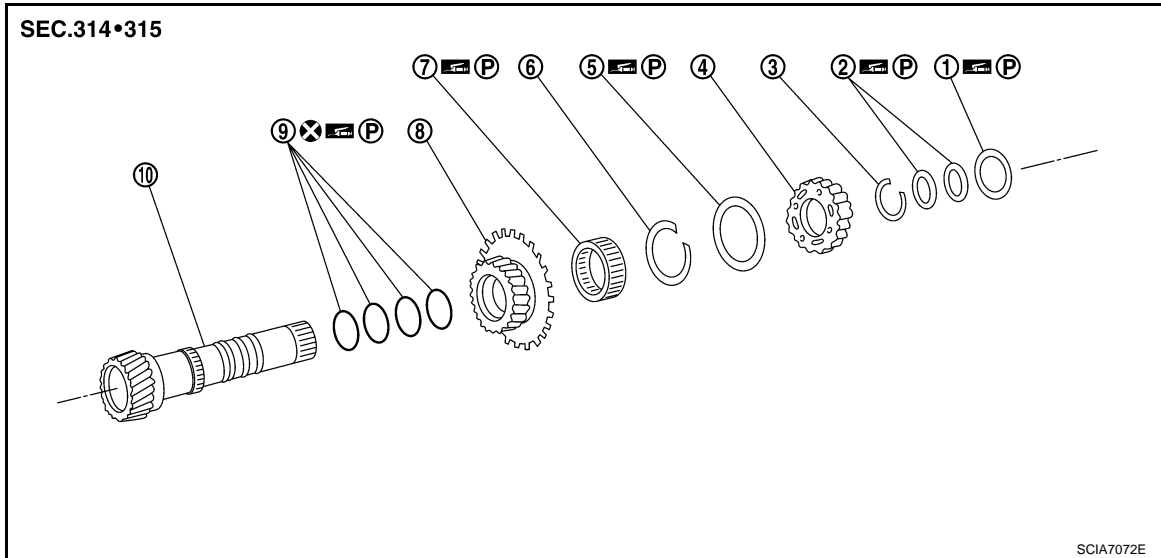

- |                                    |                   |              |
|------------------------------------|-------------------|--------------|
| 1. Needle bearing                  | 2. Bearing race   | 3. Snap ring |
| 4. High and low reverse clutch hub | 5. Needle bearing | 6. Snap ring |
| 7. 1st one-way clutch              | 8. Rear sun gear  | 9. Seal ring |
| 10. Mid sun gear                   |                   |              |

Refer to GI section to make sure icons (symbol marks) in the figure. Refer to [GI-8, "Component"](#).

## DISASSEMBLY

- Remove needle bearing and bearing races from high and low reverse clutch hub.

### • VQ35DE models

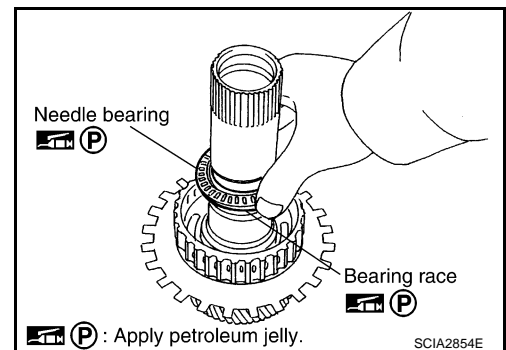

### • VK45DE models

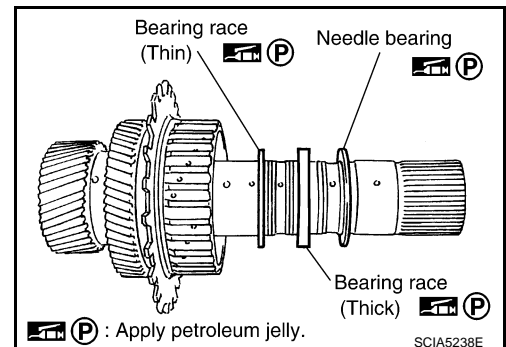



## REPAIR FOR COMPONENT PARTS

### < SERVICE INFORMATION >

- Using pair of snap ring pliers, remove snap ring from mid sun gear assembly.

**CAUTION:**

**Do not expand snap ring excessively.**

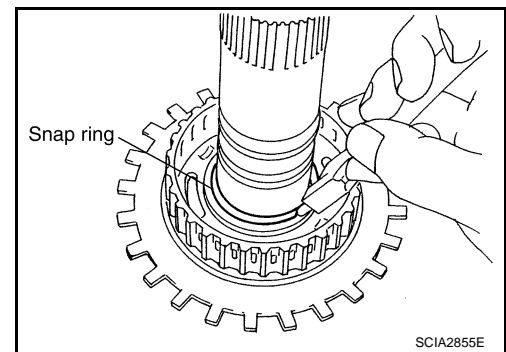

- Remove high and low reverse clutch hub from mid sun gear assembly.

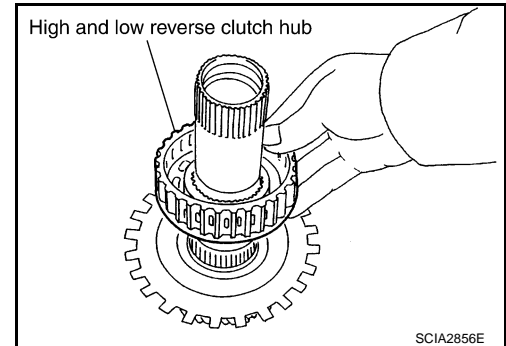

- Remove needle bearing from high and low reverse clutch hub.

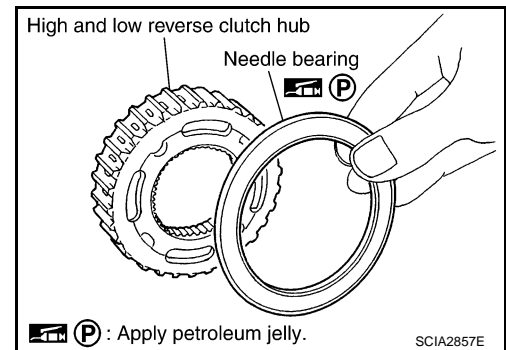

- Remove rear sun gear assembly from mid sun gear assembly.

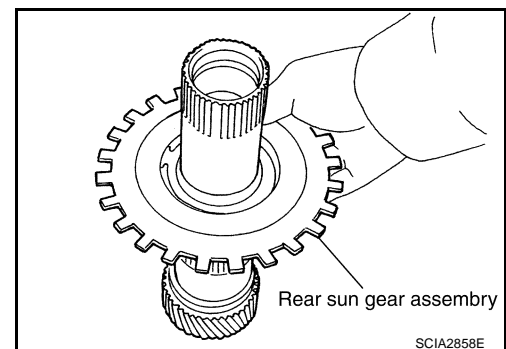

A  
B  
AT  
D  
E  
F  
G  
H  
I  
J  
K  
L  
M  
N  
O  
P

## REPAIR FOR COMPONENT PARTS

### < SERVICE INFORMATION >

- a. Using a flat-bladed screwdriver, remove snap ring from rear sun gear.

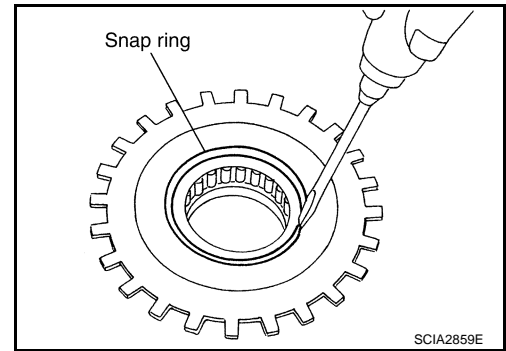

- b. Remove 1st one-way clutch from rear sun gear.

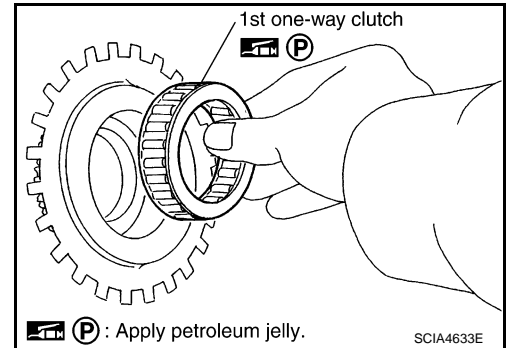

5. Remove seal rings from mid sun gear.

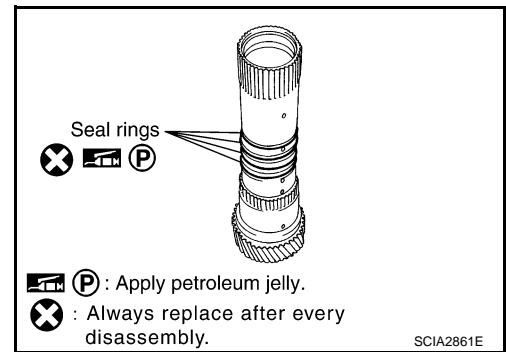

### INSPECTION

High and Low Reverse Clutch Hub Snap Ring, Rear Sun Gear Snap Ring

- Check for deformation, fatigue or damage.

**CAUTION:**

**If necessary, replace the snap ring.**

1st One-way Clutch

- Check frictional surface for wear or damage.

**CAUTION:**

**If necessary, replace the 1st one-way clutch.**

Mid Sun Gear

- Check for deformation, fatigue or damage.

**CAUTION:**

**If necessary, replace the mid sun gear.**

Rear Sun Gear

- Check for deformation, fatigue or damage.

**CAUTION:**

**If necessary, replace the rear sun gear.**

High and Low Reverse Clutch Hub

- Check for deformation, fatigue or damage.

**CAUTION:**

**If necessary, replace the high and low reverse clutch hub.**

# REPAIR FOR COMPONENT PARTS

< SERVICE INFORMATION >

## ASSEMBLY

1. Install seal rings to mid sun gear.

**CAUTION:**

- Do not reuse seal rings.
- Apply petroleum jelly to seal rings.

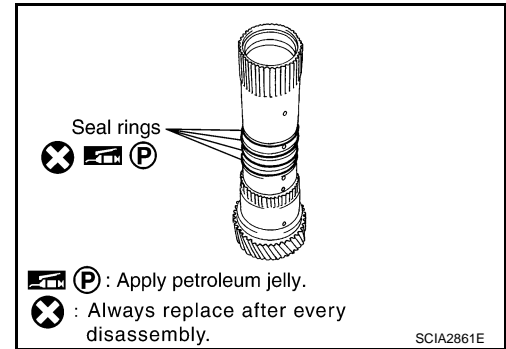

2. Install 1st one-way clutch to rear sun gear.

**CAUTION:**

- Apply petroleum jelly to 1st one-way clutch.

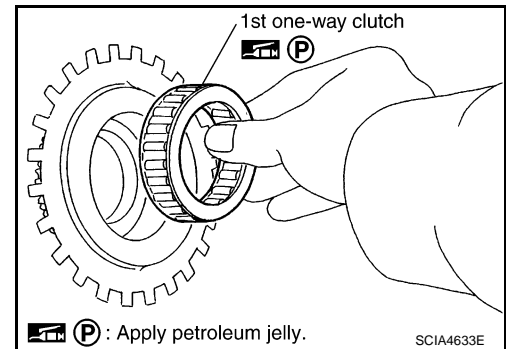

3. Using a flat-bladed screwdriver, install snap ring to rear sun gear.

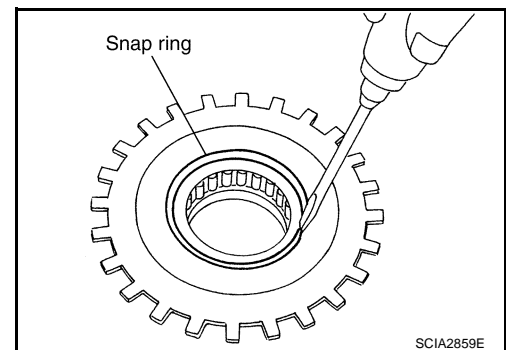

4. Install rear sun gear assembly to mid sun gear assembly.

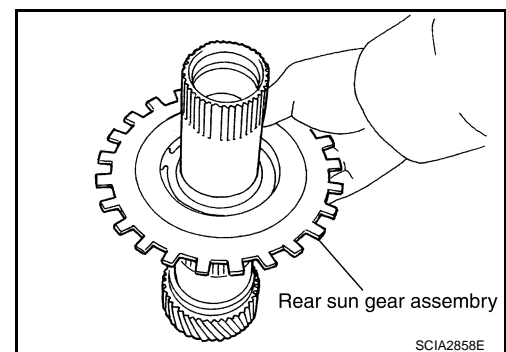

A  
B  
AT  
D  
E  
F  
G  
H  
I  
J  
K  
L  
M  
N  
O  
P

## REPAIR FOR COMPONENT PARTS

### < SERVICE INFORMATION >

5. Install needle bearing to high and low reverse clutch hub.

**CAUTION:**

- Take care with the direction of needle bearing. Refer to [AT-264, "Location of Adjusting Shims, Needle Bearings, Thrust Washers and Snap Rings"](#).
- Apply petroleum jelly to needle bearing.

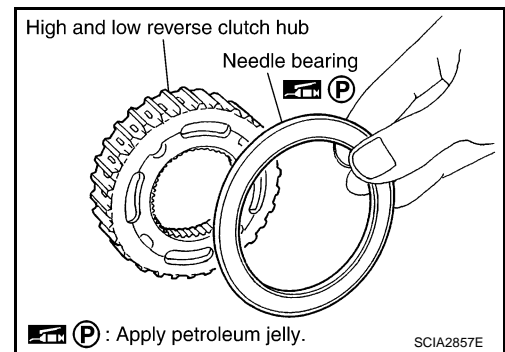

6. Install high and low reverse clutch hub to mid sun gear assembly.

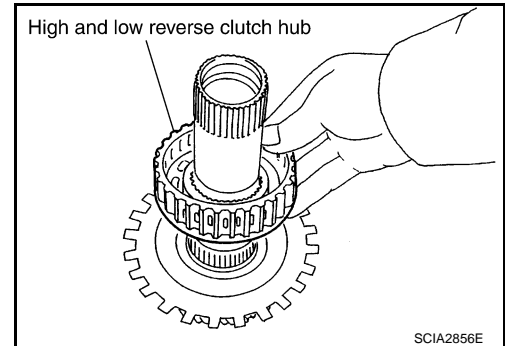

7. Using pair of snap ring pliers, install snap ring to mid sun gear assembly.

**CAUTION:**

**Do not expand snap ring excessively.**

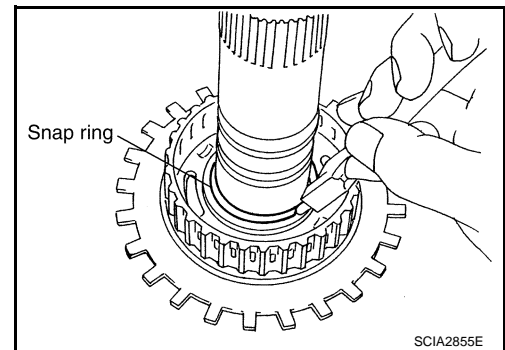

8. Check operation of 1st one-way clutch.

a. Hold mid sun gear and turn rear sun gear.

b. Check 1st one-way clutch for correct locking and unlocking directions.

**CAUTION:**

**If not as shown in the figure, check installation direction of 1st one-way clutch.**

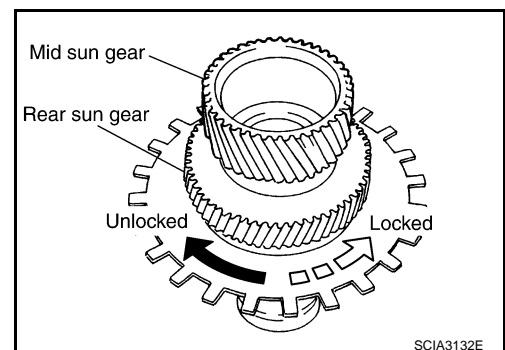

9. Install needle bearing and bearing races to high and low reverse clutch hub.

**CAUTION:**

- Take care with the direction of needle bearing . Refer to [AT-264, "Location of Adjusting Shims, Needle Bearings, Thrust Washers and Snap Rings"](#).

- Apply petroleum jelly to needle bearing and bearing races.

# REPAIR FOR COMPONENT PARTS

## < SERVICE INFORMATION >

### • VQ35DE models

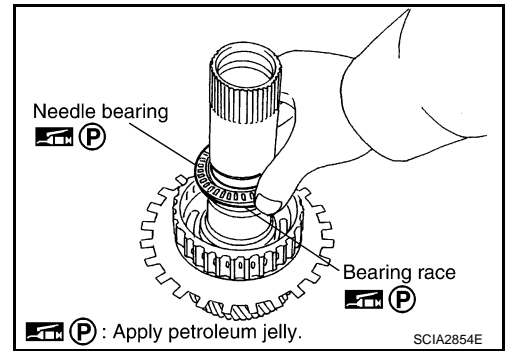

### • VK45DE models

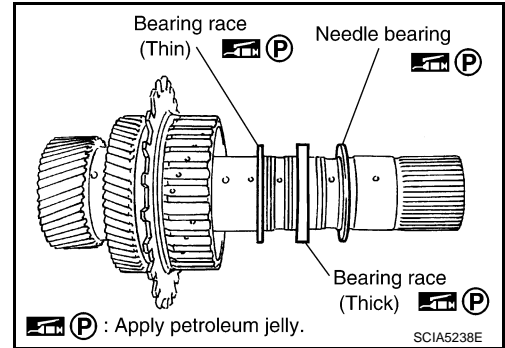

## High and Low Reverse Clutch

INFOID:000000001327408

## COMPONENTS

### VQ35DE models

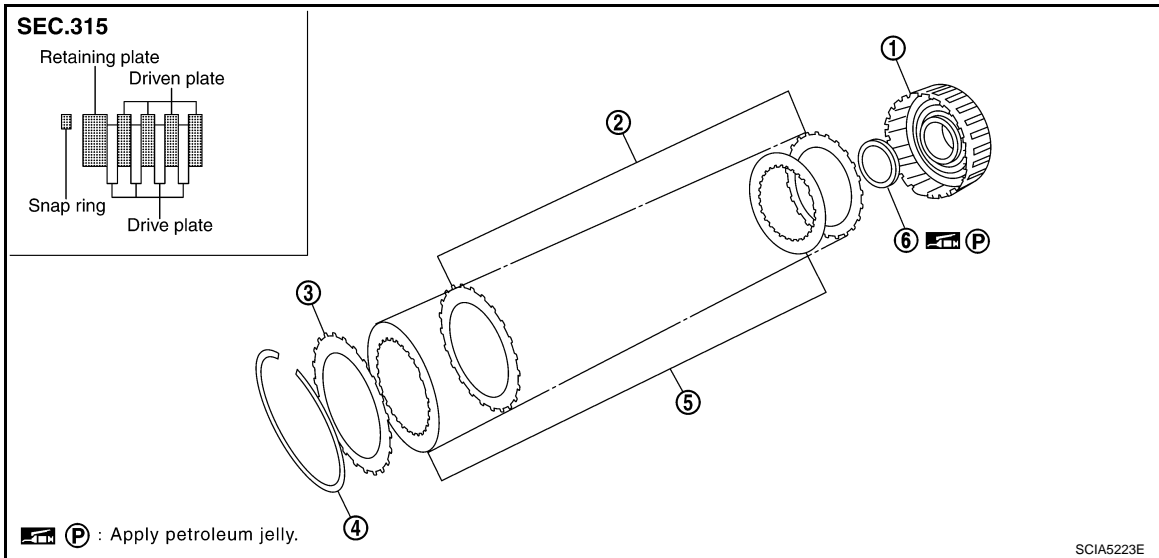

- |                                     |                 |                    |
|-------------------------------------|-----------------|--------------------|
| 1. High and low reverse clutch drum | 2. Driven plate | 3. Retaining plate |
| 4. Snap ring                        | 5. Drive plate  | 6. Bearing race    |

# REPAIR FOR COMPONENT PARTS

< SERVICE INFORMATION >

VK45DE models

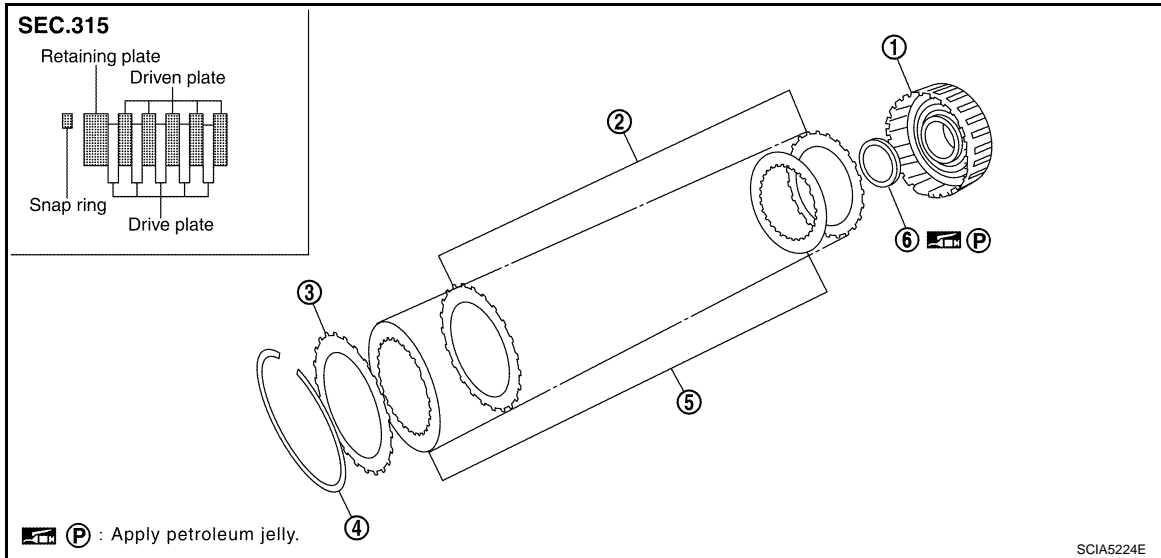

- |                                     |                 |                    |
|-------------------------------------|-----------------|--------------------|
| 1. High and low reverse clutch drum | 2. Driven plate | 3. Retaining plate |
| 4. Snap ring                        | 5. Drive plate  | 6. Bearing race    |

## DISASSEMBLY

1. Remove bearing race from high and low reverse clutch drum.

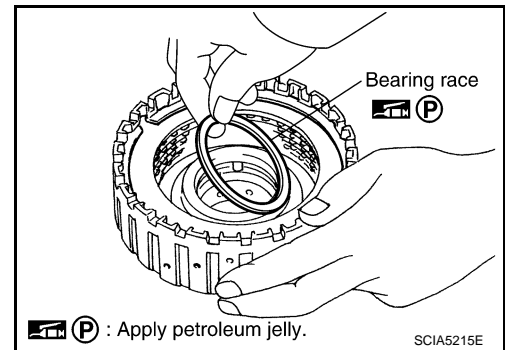

2. Using a flat-bladed screwdriver, remove snap ring from high and low reverse clutch drum.
3. Remove drive plates, driven plates and retaining plate from high and low reverse clutch drum.

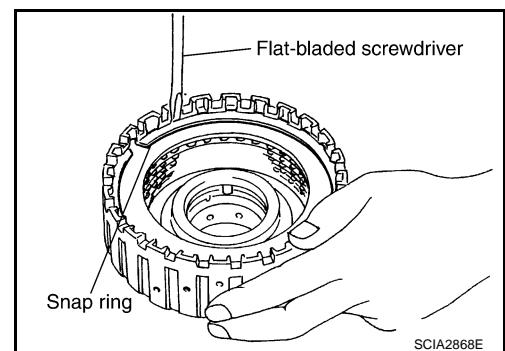

## INSPECTION

- Check the following, and replace high and low reverse clutch assembly if necessary.

High and Low Reverse Clutch Snap Ring

- Check for deformation, fatigue or damage.

High and Low Reverse Clutch Drive Plates

- Check facing for burns, cracks or damage.

High and Low Reverse Clutch Retaining Plates and Driven Plates

- Check facing for burns, cracks or damage.

## ASSEMBLY

1. Install drive plates, driven plates and retaining plate in high and low reverse clutch drum.

# REPAIR FOR COMPONENT PARTS

## < SERVICE INFORMATION >

### CAUTION:

Take care with order of plates.

- Using a flat-bladed screwdriver, install snap ring in high and low reverse clutch drum.

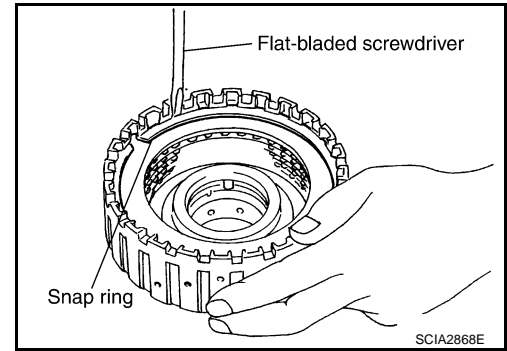

- Install bearing race to high and low reverse clutch drum.

### CAUTION:

Take care with the direction of needle bearing. Refer to [AT-264, "Location of Adjusting Shims, Needle Bearings, Thrust Washers and Snap Rings"](#).

- Apply petroleum jelly to bearing race.

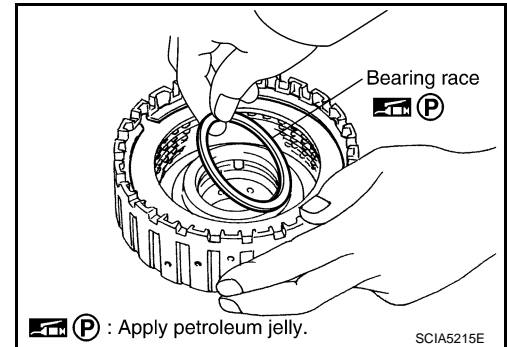

## Direct Clutch

INFOID:000000001327409

## COMPONENTS

### VQ35DE models

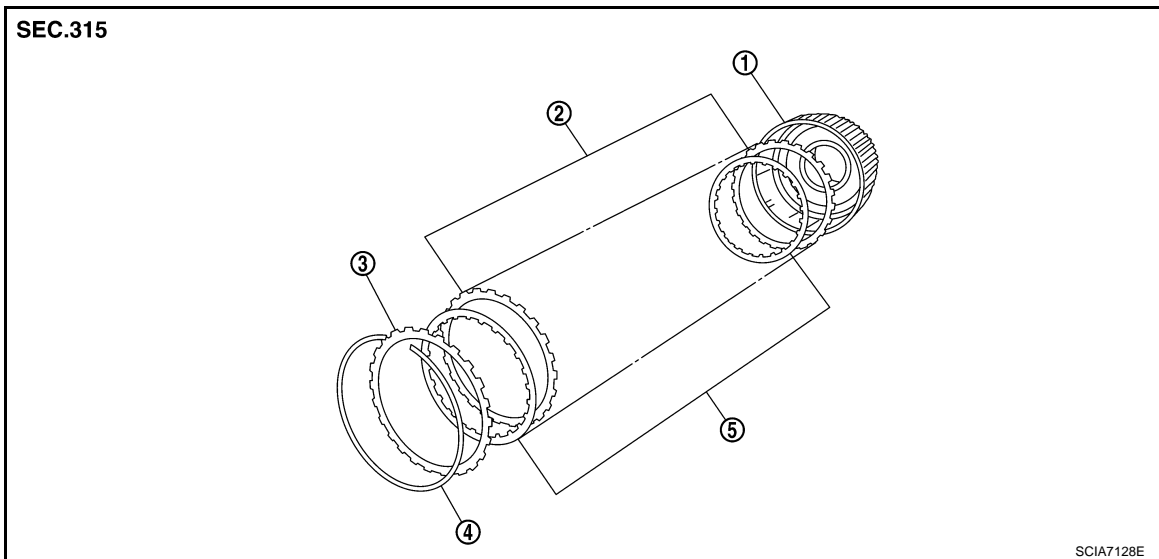

- |                       |                 |                    |
|-----------------------|-----------------|--------------------|
| 1. Direct clutch drum | 2. Driven plate | 3. Retaining plate |
| 4. Snap ring          | 5. Drive plate  |                    |

# REPAIR FOR COMPONENT PARTS

< SERVICE INFORMATION >

VK45DE models

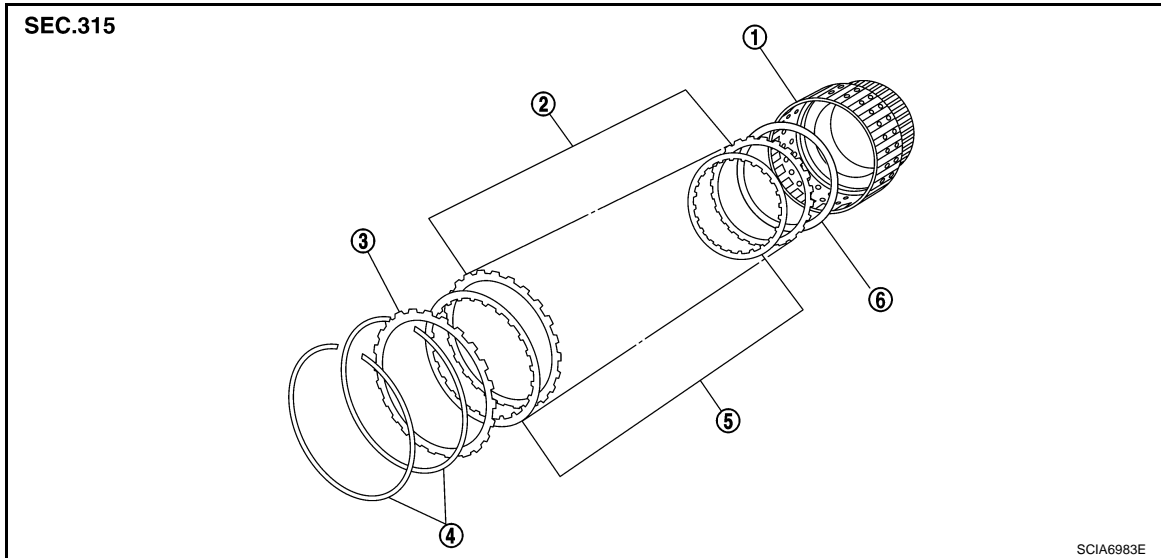

- |                       |                 |                    |
|-----------------------|-----------------|--------------------|
| 1. Direct clutch drum | 2. Driven plate | 3. Retaining plate |
| 4. Snap ring          | 5. Drive plate  | 6. Dish plate      |

## DISASSEMBLY

1. Using a flat-bladed screwdriver, remove snap ring from direct clutch drum.
2. Remove drive plates, driven plates, retaining plate and dish plate\* from direct clutch drum.  
\*: VK45DE models

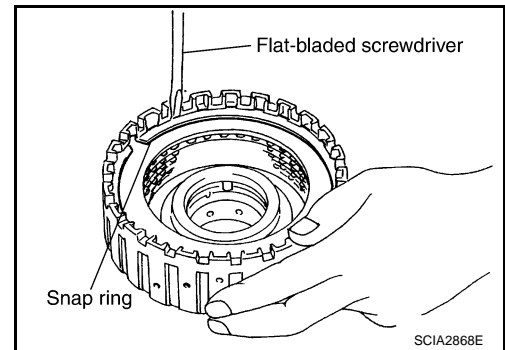

## INSPECTION

- Check the following, and replace direct clutch assembly if necessary.

Direct Clutch Snap Ring

- Check for deformation, fatigue or damage.

Direct Clutch Drive Plates

- Check facing for burns, cracks or damage.

Direct Clutch Retaining Plates, Driven Plates and Dish Plate\*

- Check facing for burns, cracks or damage.

\*: VK45DE models

## ASSEMBLY

1. Install drive plates, driven plates, retaining plate and dish plate\* in direct clutch drum.  
\*: VK45DE models

### CAUTION:

Take care with order of plates.



# REPAIR FOR COMPONENT PARTS

## < SERVICE INFORMATION >

### • VQ35DE models

- Snap ring (1)
- Retaining plate (2)
- Drive plate (3)
- Driven plate (4)
- Drive plate/Driven plate: 5/5

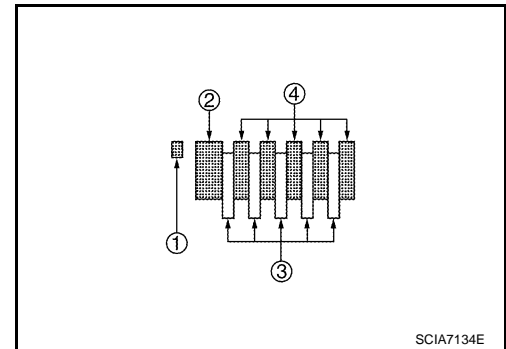

### • VK45DE models

- Snap ring (1)
- Retaining plate (2)
- Drive plate (3)
- Driven plate (4)
- Dish plate (5)
- Drive plate/Driven plate: 6/6

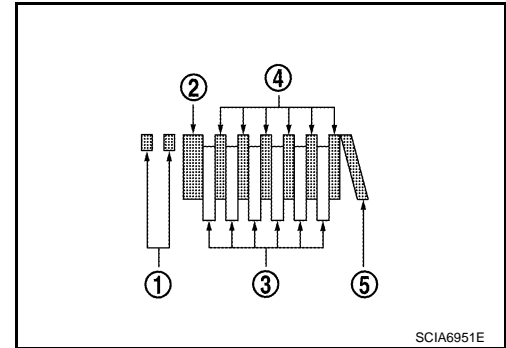

2. Using a flat-bladed screwdriver, install snap ring in direct clutch drum.

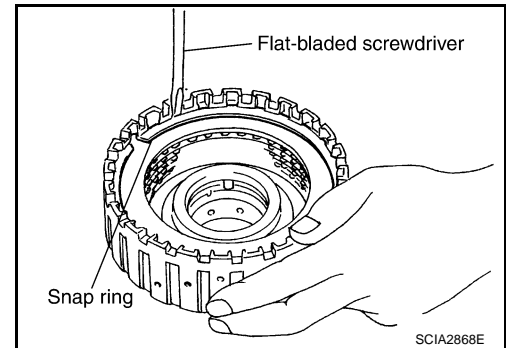

A  
B  
AT  
D  
E  
F  
G  
H  
I  
J  
K  
L  
M  
N  
O  
P

# ASSEMBLY

< SERVICE INFORMATION >

## ASSEMBLY

### Assembly (1)

INFOID:000000001327410

1. As shown in the figure, use a drift [commercial service tool: 22 mm (0.87 in) dia.] to drive manual shaft oil seals into the transmission case until it is flush.

**CAUTION:**

- Do not reuse manual shaft oil seals.
- Apply ATF to manual shaft oil seals.

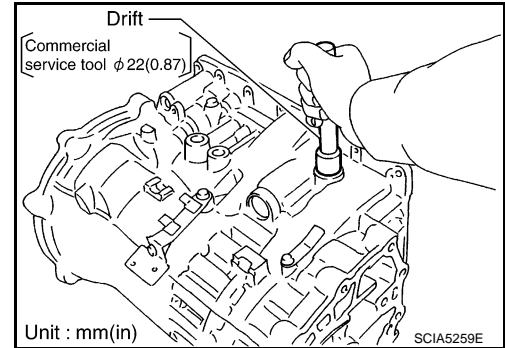

2. Install detent spring and spacer in transmission case, and then tighten detent spring and spacer mounting bolt to the specified torque. Refer to [AT-249, "Component"](#).

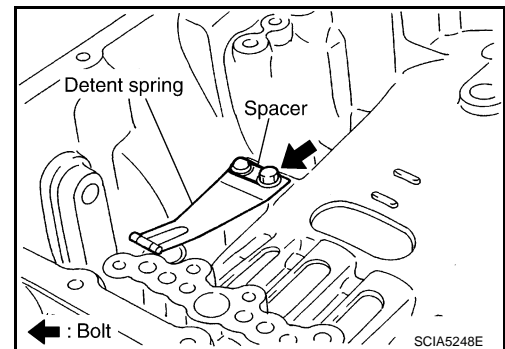

3. Install manual shaft to transmission case.

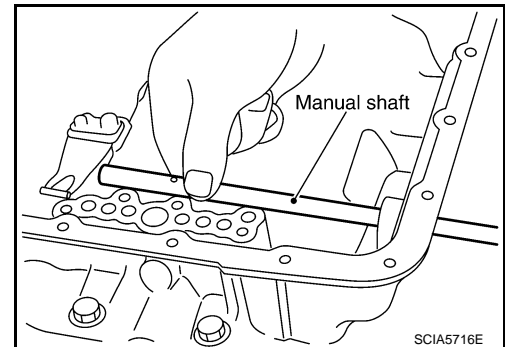

4. Install parking rod to manual plate.

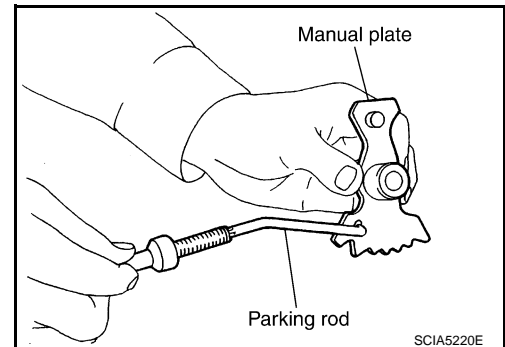

# ASSEMBLY

## < SERVICE INFORMATION >

5. Install manual plate (with parking rod) to manual shaft.

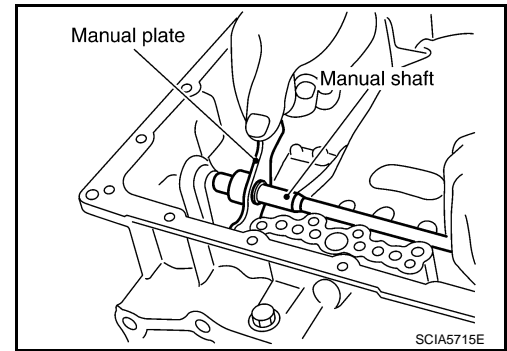

6. Install retaining pin into the manual plate and manual shaft.
- Fit pinhole of the manual plate to pinhole of the manual shaft with a pin punch.
  - Use a hammer to tap the retaining pin into the manual plate.

**CAUTION:**

- Do not reuse retaining pin.
- Drive retaining pin to  $2 \pm 0.5$  mm ( $0.08 \pm 0.020$  in) over the manual plate.

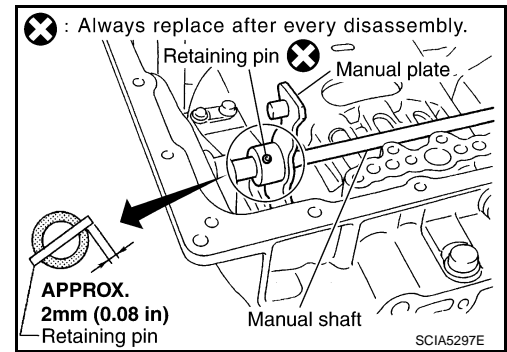

7. Install retaining pin into the transmission case and manual shaft.
- Fit pinhole of the transmission case to pinhole of the manual shaft with a pin punch.
  - Use a hammer to tap the retaining pin into the transmission case.

**CAUTION:**

- Do not reuse retaining pin.
- Drive retaining pin to  $5 \pm 1$  mm ( $0.20 \pm 0.04$  in) over the transmission case.

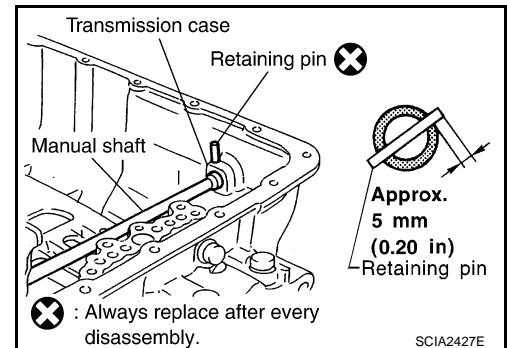

8. Install O-rings to servo assembly.

**CAUTION:**

- Do not reuse O-rings.
- Apply petroleum jelly to O-rings.

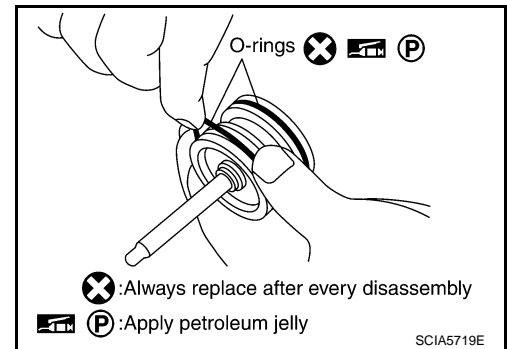

A  
B  
AT  
D  
E  
F  
G  
H  
I  
J  
K  
L  
M  
N  
O  
P

# ASSEMBLY

## < SERVICE INFORMATION >

9. Install return spring to servo assembly.

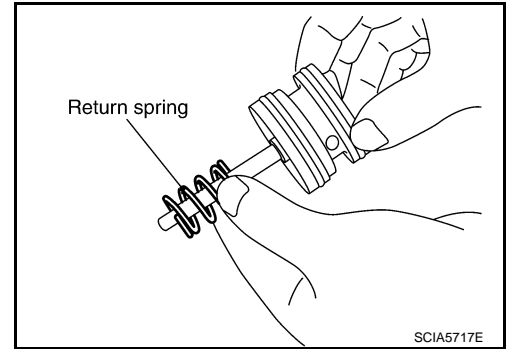

10. Install servo assembly in transmission case.

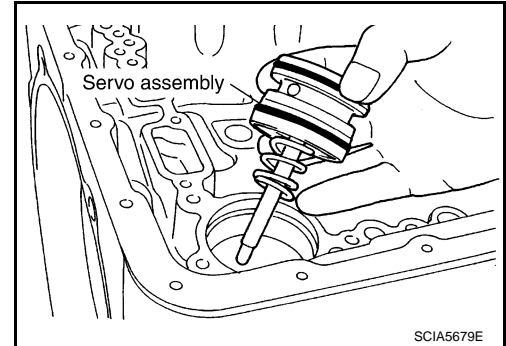

11. Using pair of snap ring pliers, install snap ring to transmission case.

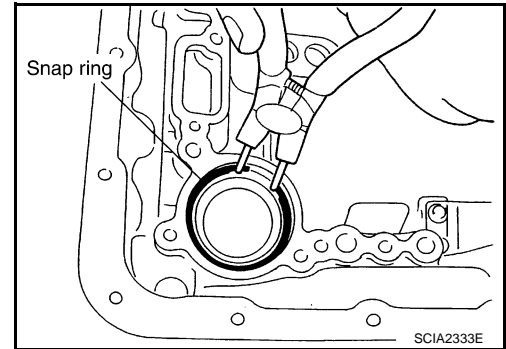

12. Install D-rings in reverse brake piston.

**CAUTION:**

- Do not reuse D-rings.
- Apply ATF to D-rings.

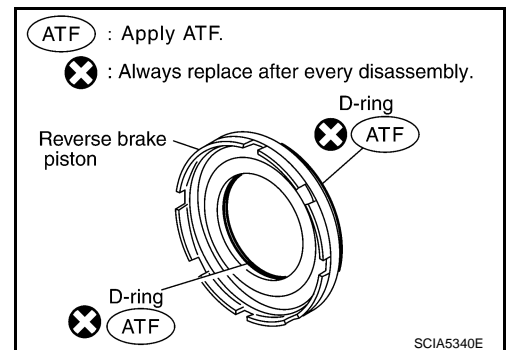

13. Install reverse brake piston in transmission case.

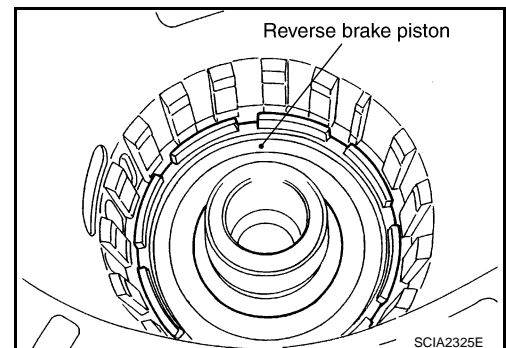

# ASSEMBLY

## < SERVICE INFORMATION >

14. Install needle bearing to drum support edge surface.

**CAUTION:**

- Take care with the direction of needle bearing. Refer to [AT-264, "Location of Adjusting Shims, Needle Bearings, Thrust Washers and Snap Rings"](#).
- Apply petroleum jelly to needle bearing.

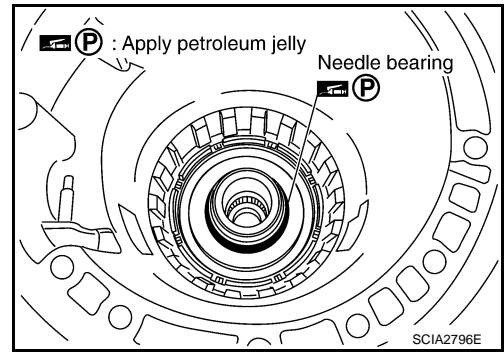

15. Install seal rings to drum support.

**CAUTION:**

- Do not reuse seal rings.
- Apply petroleum jelly to seal rings.

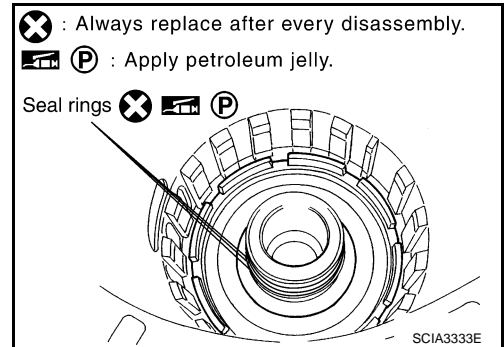

16. Install spring retainer and return spring in transmission case.

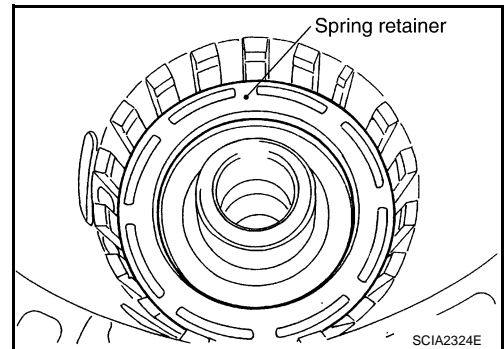

17. Set the SST on spring retainer and install snap ring (fixing spring retainer) in transmission case while compressing return spring.

**CAUTION:**

- Securely assemble them using a flat-bladed screwdriver so that snap ring tension is slightly weak.

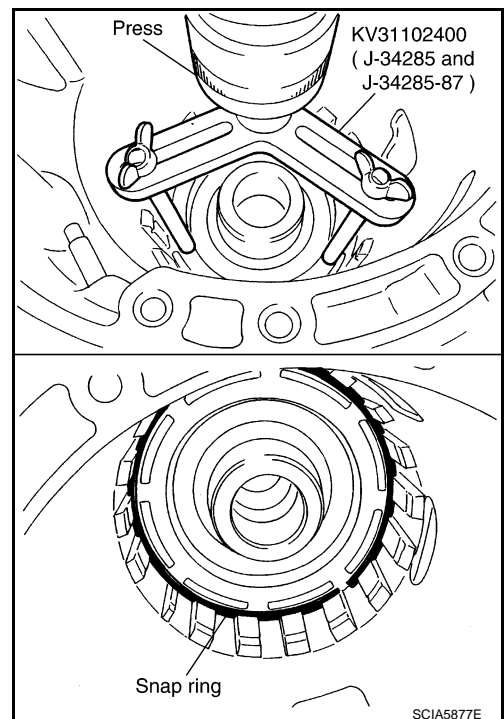

A  
B  
AT  
D  
E  
F  
G  
H  
I  
J  
K  
L  
M  
N  
O  
P

# ASSEMBLY

## < SERVICE INFORMATION >

18. Install reverse brake drive plates, driven plates and dish plates in transmission case.

**CAUTION:**

**Take care with order of plates.**

- VQ35DE models

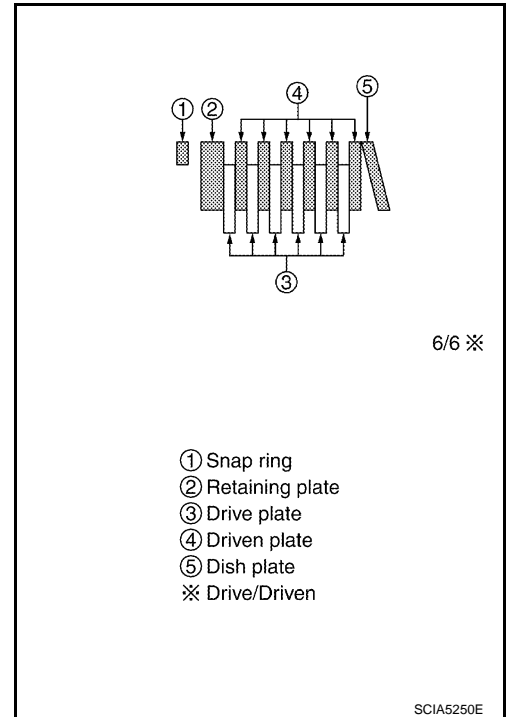

- VK45DE models

- Snap ring (1)
- Retaining plate (2)
- Drive plate (3)
- Driven plate (4)
- Dish plate (5)
- Drive plate/Driven plate: 6/6

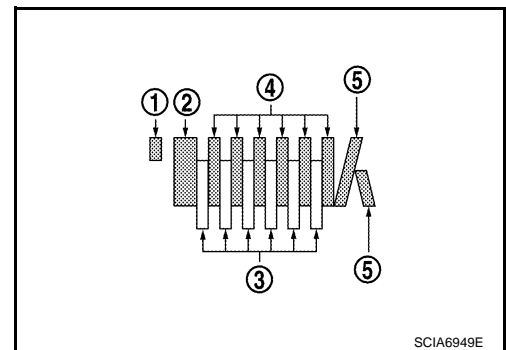

# ASSEMBLY

## < SERVICE INFORMATION >

19. Assemble N-spring.
20. Install reverse brake retaining plate in transmission case.

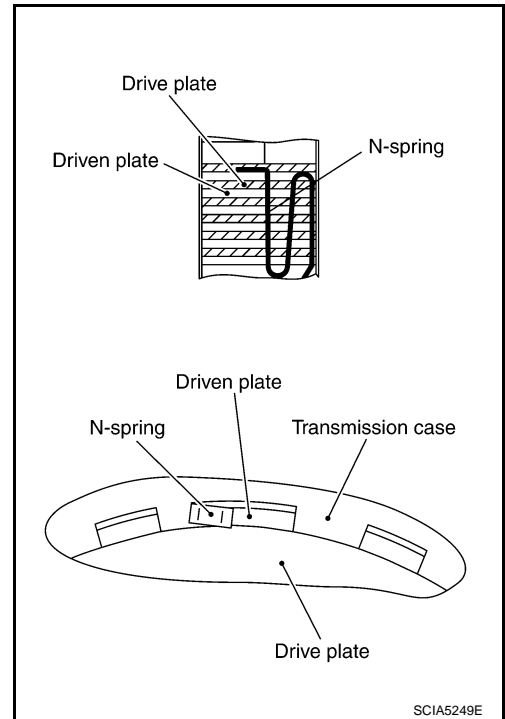

21. Install snap ring in transmission case.

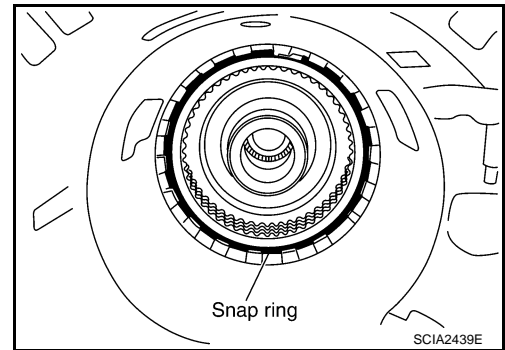

22. Measure clearance between retaining plate and snap ring. If not within specified clearance, select proper retaining plate. Refer to "Parts Information" for retaining plate.

**Specified clearance "A"**

**Standard : 0.7 - 1.1 mm (0.028 - 0.043 in)**

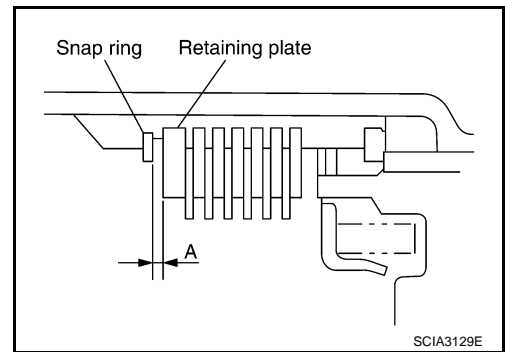

23. Install needle bearing to transmission case.

**CAUTION:**

- Take care with the direction of needle bearing. Refer to [AT-264, "Location of Adjusting Shims, Needle Bearings, Thrust Washers and Snap Rings"](#).
- Apply petroleum jelly to needle bearing.

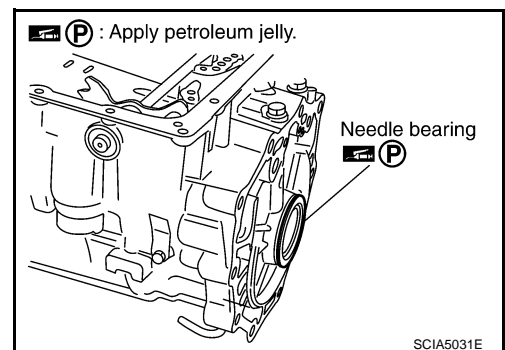

A  
B  
AT  
D  
E  
F  
G  
H  
I  
J  
K  
L  
M  
N  
O  
P

# ASSEMBLY

## < SERVICE INFORMATION >

24. Install revolution sensor to transmission case, and then tighten revolution sensor mounting bolt to the specified torque. Refer to [AT-249. "Component"](#).

**CAUTION:**

- Do not subject it to impact by dropping or hitting it.
- Do not disassemble.
- Do not allow metal filings, etc. to get on the sensor's front edge magnetic area.
- Do not place in an area affected by magnetism.

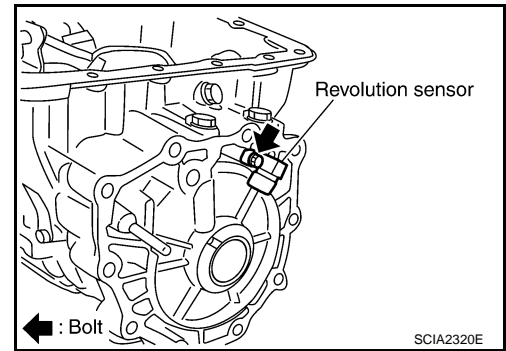

25. As shown in the figure, use the drift to drive rear oil seal into the rear extension (2WD models) or adapter case (AWD models) until it is flush.

**CAUTION:**

- Do not reuse rear oil seal.
- Apply ATF to rear oil seal.

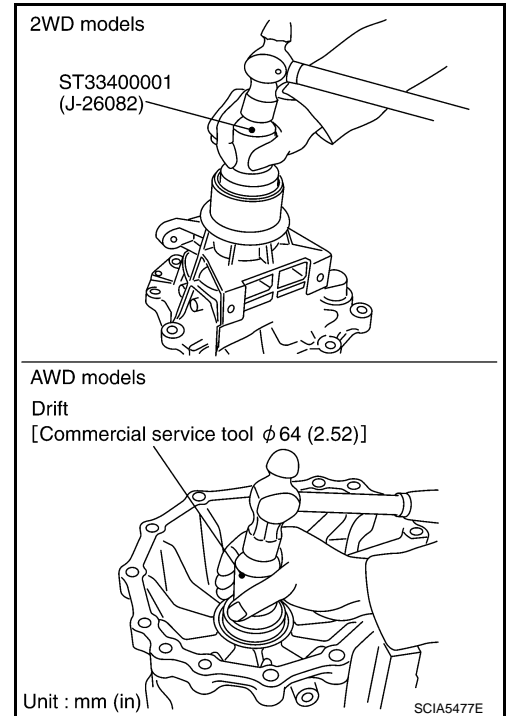

26. Install return spring to parking pawl.
- VQ35DE models

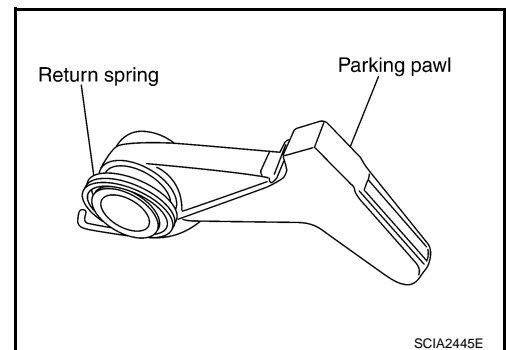



# ASSEMBLY

## < SERVICE INFORMATION >

- **VK45DE models**
- Return spring (1)
- Parking pawl (2)

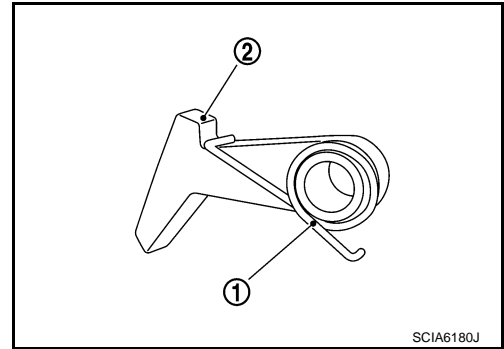

27. Install parking pawl (with return spring) and pawl shaft to rear extension (2WD models) or adapter case (AWD models).

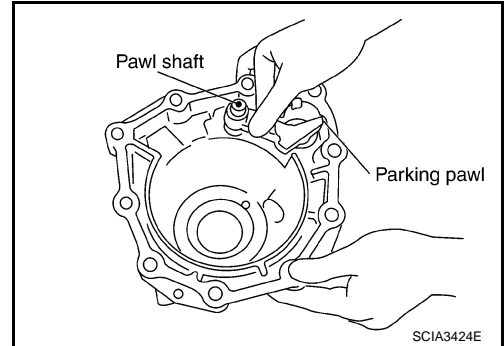

28. Install parking actuator support to rear extension (2WD models) or adapter case (AWD models).

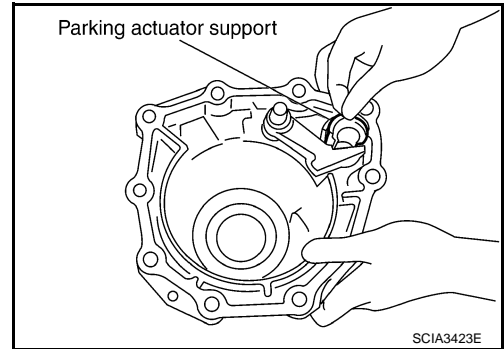

29. Install needle bearing to rear extension (2WD models) or adapter case (AWD models).

**CAUTION:**

- Take care with the direction of needle bearing. Refer to [AT-264, "Location of Adjusting Shims, Needle Bearings, Thrust Washers and Snap Rings"](#).
- Apply petroleum jelly to needle bearing.

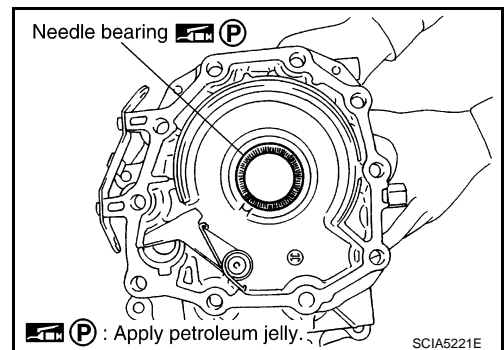

30. Install seal rings to output shaft.

**CAUTION:**

- Do not reuse seal rings.
- Apply petroleum jelly to seal rings.

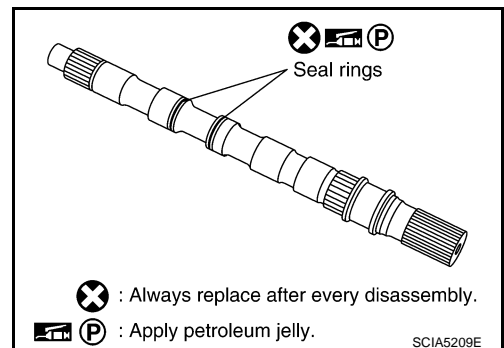

A  
B  
AT  
D  
E  
F  
G  
H  
I  
J  
K  
L  
M  
N  
O  
P

# ASSEMBLY

## < SERVICE INFORMATION >

31. Install parking gear to output shaft.

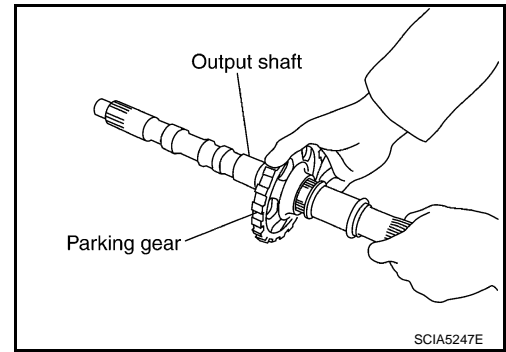

32. Install output shaft in transmission case.

**CAUTION:**

Be careful not to mistake front for rear because both sides looks similar. (Thinner end is front side.)

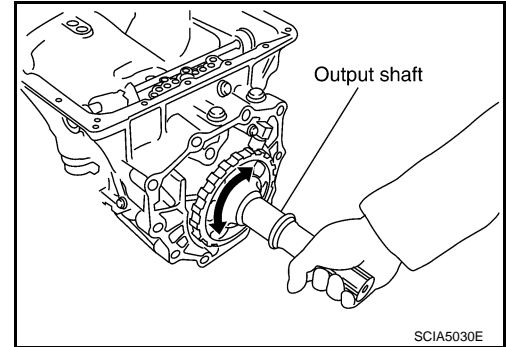

33. Install bearing race to output shaft.

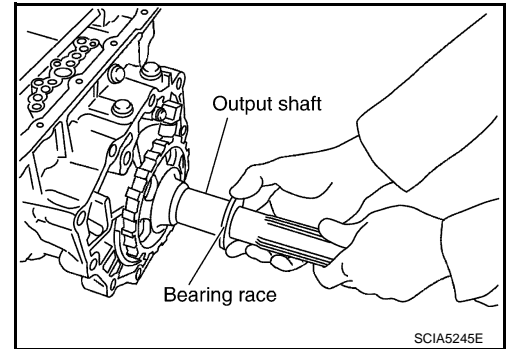

34. Install rear extension assembly (2WD models) or adapter case assembly (AWD models) according to the following procedures.

a. **2WD models**

i. Apply recommended sealant (Genuine Anaerobic Liquid Gasket or equivalent. Refer to [GI-44, "Recommended Chemical Product and Sealant"](#).) to rear extension assembly as shown in the figure.

**CAUTION:**

Completely remove all moisture, oil and old sealant, etc. from the transmission case and rear extension assembly mounting surfaces.

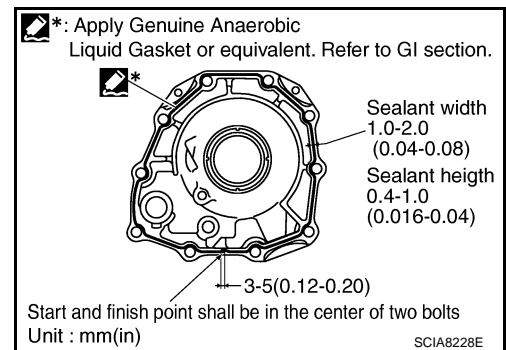

# ASSEMBLY

## < SERVICE INFORMATION >

- ii. Install rear extension assembly to transmission case.

**CAUTION:**

Insert the tip of parking rod between the parking pawl and the parking actuator support when assembling the rear extension assembly.

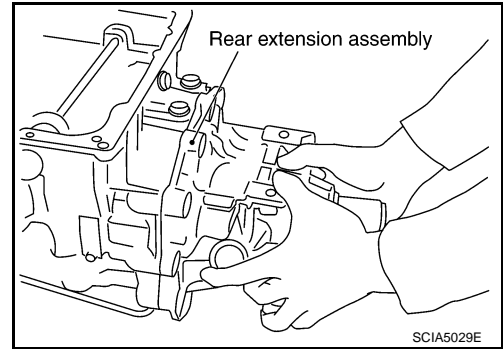

- iii. Tighten rear extension assembly mounting bolts to specified torque. Refer to [AT-249, "Component"](#).

**CAUTION:**

Do not reuse self-sealing bolts.

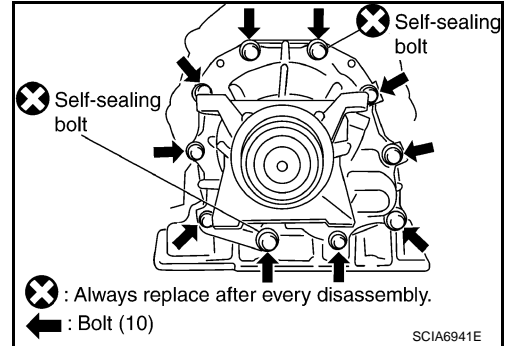

- b. **AWD models**

- i. Install gasket onto transmission case.

**CAUTION:**

- Do not reuse gasket.
- Completely remove all moisture, oil and old gasket, etc. from the transmission case and adapter case assembly mounting surfaces.

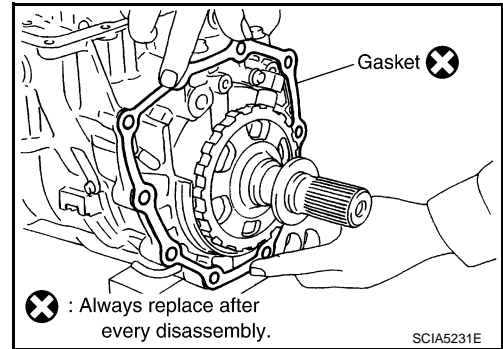

- ii. Install adapter case assembly to transmission case.

**CAUTION:**

Insert the tip of parking rod between the parking pawl and the parking actuator support when assembling the rear extension assembly.

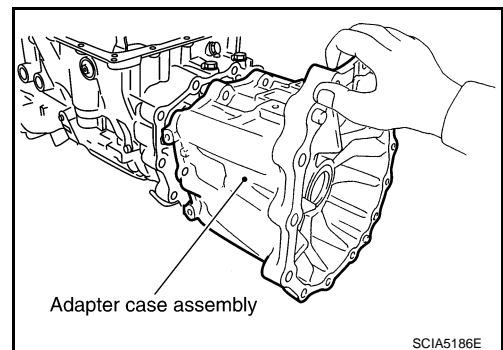

A  
B  
AT  
D  
E  
F  
G  
H  
I  
J  
K  
L  
M  
N  
O  
P

# ASSEMBLY

## < SERVICE INFORMATION >

- iii. Tighten adapter case assembly mounting bolts (1) to specified torque. [With bracket (2).] Refer to [AT-249, "Component"](#).

←: Bolt (10)

**CAUTION:**

**Do not reuse self-sealing bolts (3).**

Refer to GI section to mark sure icons (symbol marks) in the figure. Refer to [GI-8, "Component"](#).

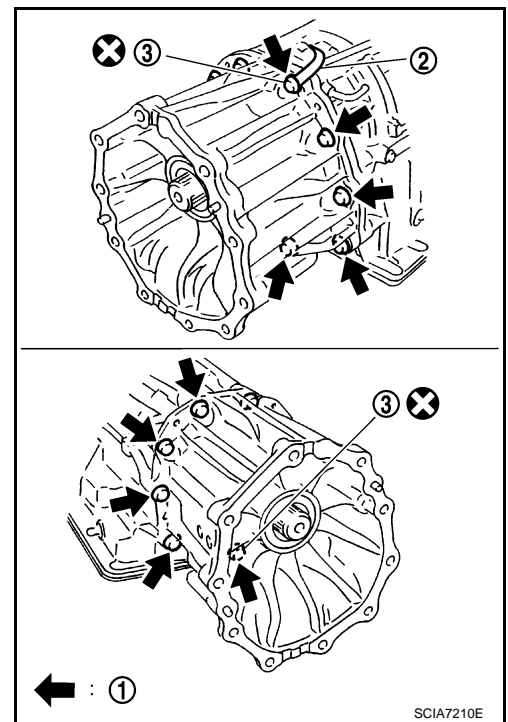

35. Install needle bearing in drum support.

**CAUTION:**

- Take care with the direction of needle bearing. Refer to [AT-264, "Location of Adjusting Shims, Needle Bearings, Thrust Washers and Snap Rings"](#).
- Apply petroleum jelly to needle bearing.

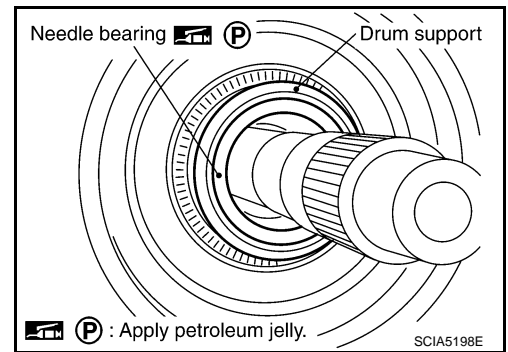

36. Install direct clutch assembly in reverse brake.

**CAUTION:**

**Make sure that drum support edge surface and direct clutch inner boss edge surface come to almost same place.**

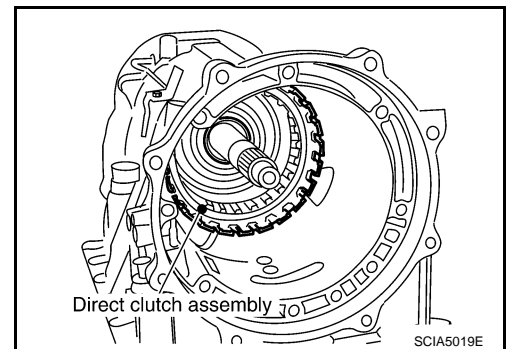

37. Install high and low reverse clutch assembly in direct clutch.

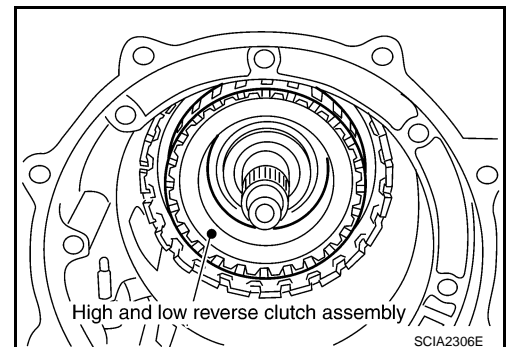

# ASSEMBLY

## < SERVICE INFORMATION >

38. Using a flat-bladed screwdriver, align drive plate.

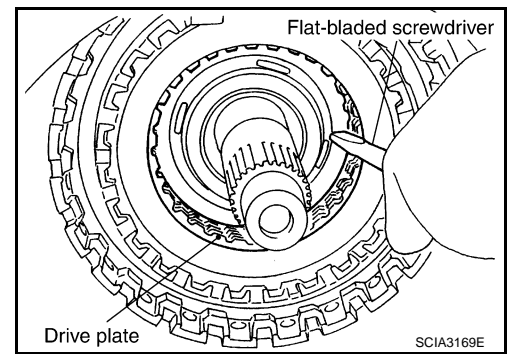

39. Install high and low reverse clutch hub, mid sun gear assembly and rear sun gear assembly as a unit.

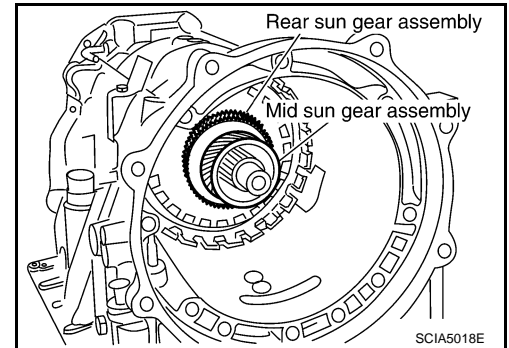

### CAUTION:

Check that portion "A" of high and low reverse clutch drum protrudes approximately 2 mm (0.08 in) beyond portion "B" of rear sun gear.

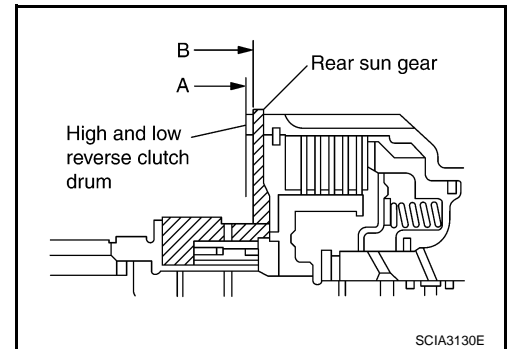

40. Install needle bearing in rear carrier assembly.

### CAUTION:

- Take care with the direction of needle bearing. Refer to [AT-264, "Location of Adjusting Shims, Needle Bearings, Thrust Washers and Snap Rings"](#).
- Apply petroleum jelly to needle bearing.

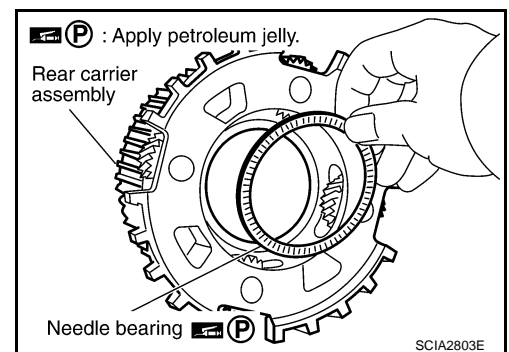

# ASSEMBLY

## < SERVICE INFORMATION >

41. Install bearing race in rear carrier assembly.

**CAUTION:**

Apply petroleum jelly to bearing race.

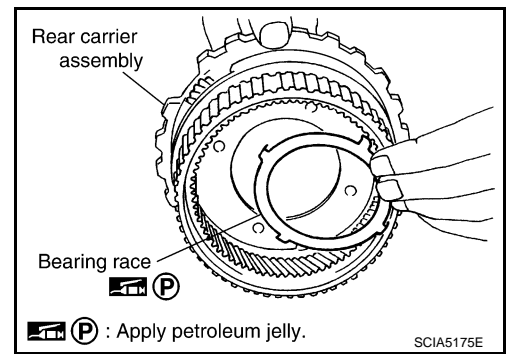

42. Install rear carrier assembly in direct clutch drum.

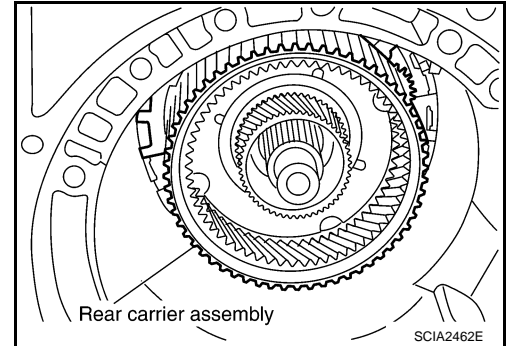

43. Install needle bearing (rear side) to mid carrier assembly.

**CAUTION:**

- Take care with the direction of needle bearing. Refer to [AT-264, "Location of Adjusting Shims, Needle Bearings, Thrust Washers and Snap Rings"](#).
- Apply petroleum jelly to needle bearing.

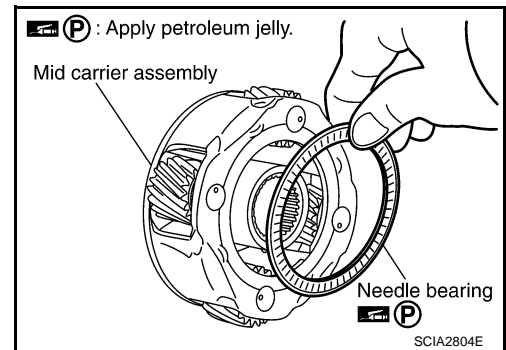

44. Install needle bearing (front side) to mid carrier assembly.

**CAUTION:**

- Take care with the direction of needle bearing. Refer to [AT-264, "Location of Adjusting Shims, Needle Bearings, Thrust Washers and Snap Rings"](#).
- Apply petroleum jelly to needle bearing.

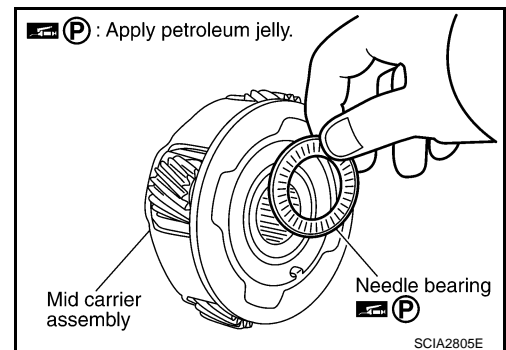

45. Install mid carrier assembly in rear carrier assembly.

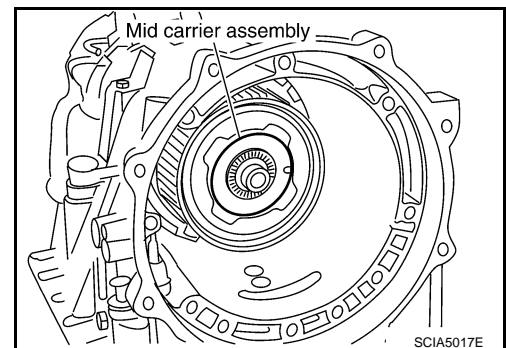

# ASSEMBLY

## < SERVICE INFORMATION >

46. Install front carrier assembly, input clutch assembly and rear internal gear as a unit.

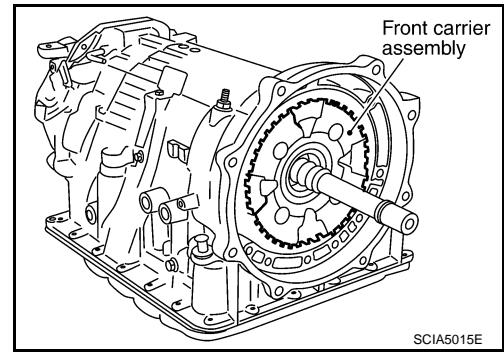

47. Install seal rings in input clutch assembly.

**CAUTION:**

- Do not reuse seal rings.
- Apply petroleum jelly to seal rings.

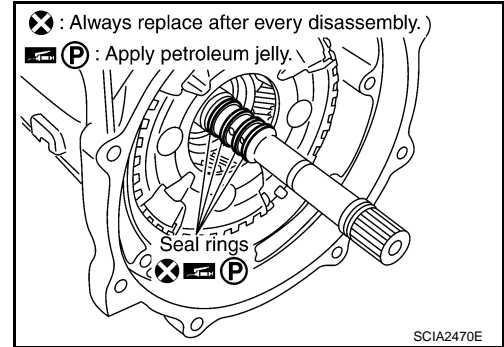

48. Install band servo anchor end pin and lock nut in transmission case.

**CAUTION:**

- Do not reuse band servo anchor end pin.

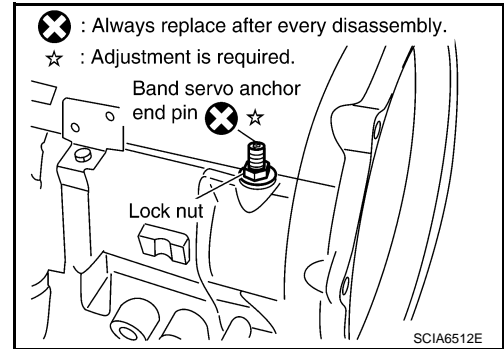

49. Install brake band in transmission case.

**CAUTION:**

- Assemble it so that identification to avoid incorrect installation faces servo side.

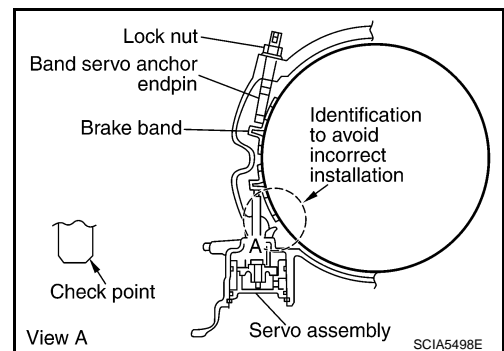

50. Install front sun gear to front carrier assembly.

**CAUTION:**

- Apply ATF to front sun gear bearing and 3rd one-way clutch end bearing.

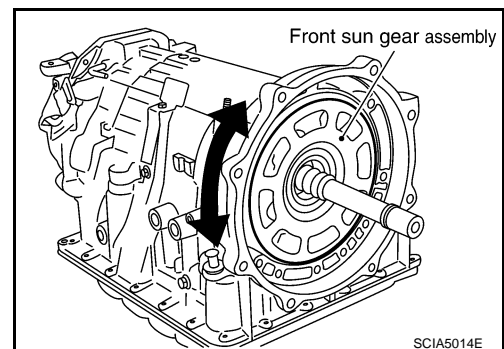

A  
B  
AT  
D  
E  
F  
G  
H  
I  
J  
K  
L  
M  
N  
O  
P



# ASSEMBLY

## < SERVICE INFORMATION >

51. Install needle bearing to front sun gear.

**CAUTION:**

- Take care with the direction of needle bearing. Refer to [AT-264, "Location of Adjusting Shims, Needle Bearings, Thrust Washers and Snap Rings"](#).
- Apply petroleum jelly to needle bearing.

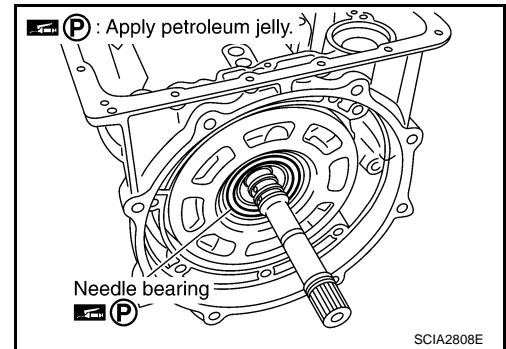

52. Adjust brake band tilting using clips so that brake band contacts front sun gear drum evenly.

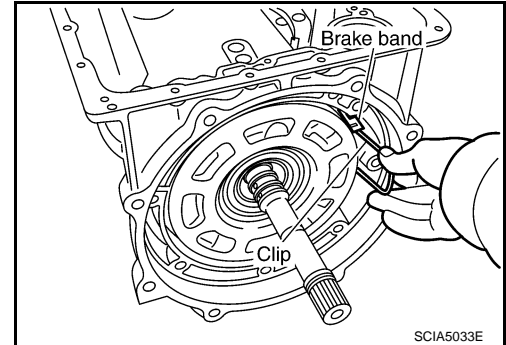

53. Adjust brake band.

- a. Loosen lock nut.
- b. Tighten band servo anchor end pin to the specified torque.

 : 5.0 N·m (0.51 kg-m, 44 in-lb)

- c. Back of band servo anchor end pin three turns.
- d. Holding band servo anchor end pin, tighten lock nut to the specified torque. Refer to [AT-249, "Component"](#).

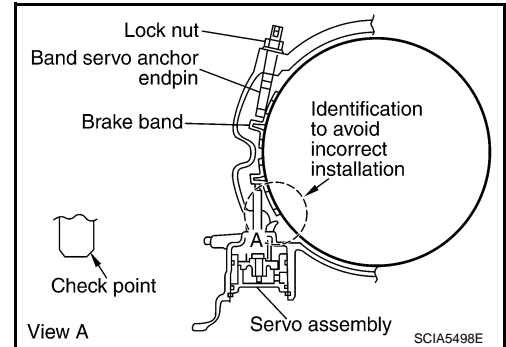

## Adjustment

INFOID:000000001327411

### TOTAL END PLAY

- Measure clearance between front sun gear and bearing race for oil pump cover.
- Select proper thickness of bearing race so that end play is within specifications.

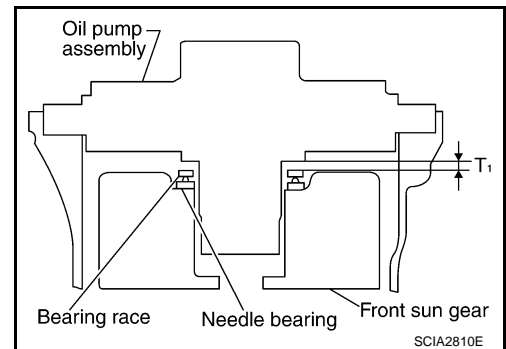



# ASSEMBLY

## < SERVICE INFORMATION >

1. Measure dimensions "K" and "L" and then calculate dimension "J".

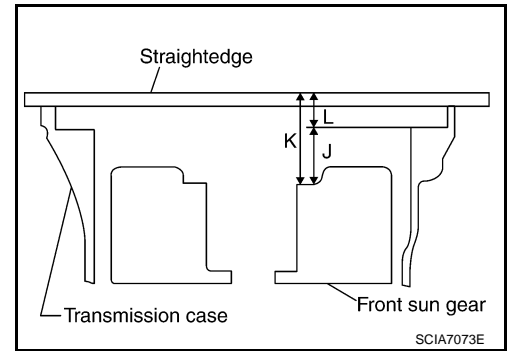

- a. Measure dimension "K".

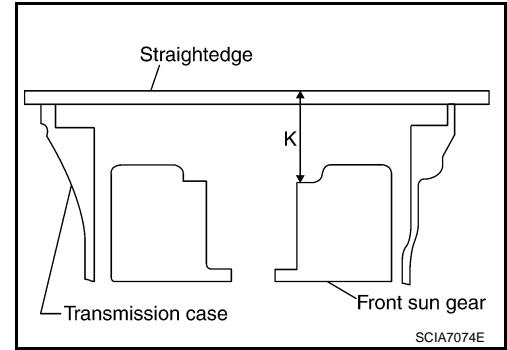

- b. Measure dimension "L".
- c. Calculate dimension "J".

**"J" : Distance between oil pump fitting surface of transmission case and needle bearing mating surface of front sun gear.**

$$J = K - L$$

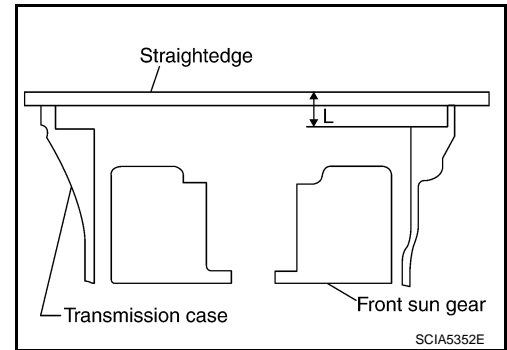

2. Measure dimensions "M1" and "M2" and then calculate dimension "M".

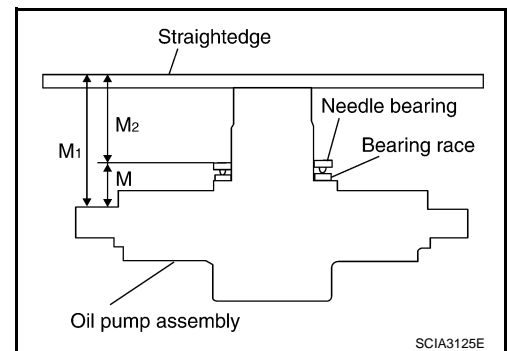

- a. Place bearing race and needle bearing on oil pump assembly.

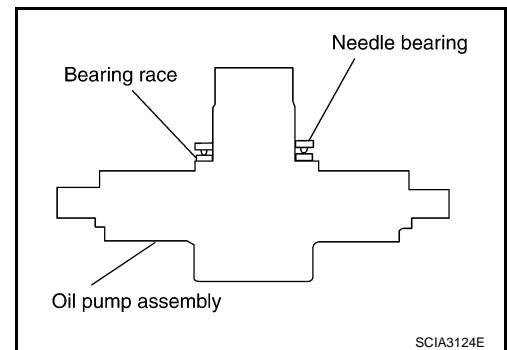

# ASSEMBLY

## < SERVICE INFORMATION >

b. Measure dimension "M1".

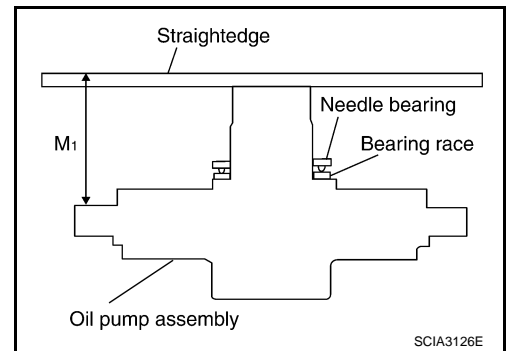

c. Measure dimension "M2".

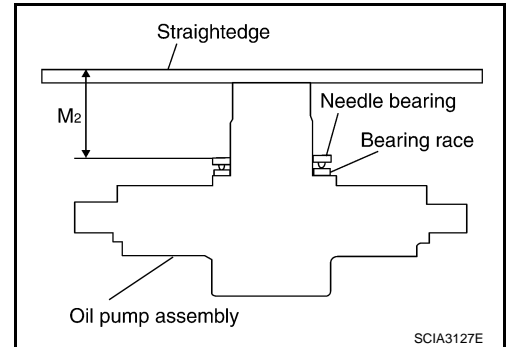

d. Calculate dimension "M".

**"M"** : Distance between transmission case fitting surface of oil pump and needle bearing on oil pump.

$$M = M_1 - M_2$$

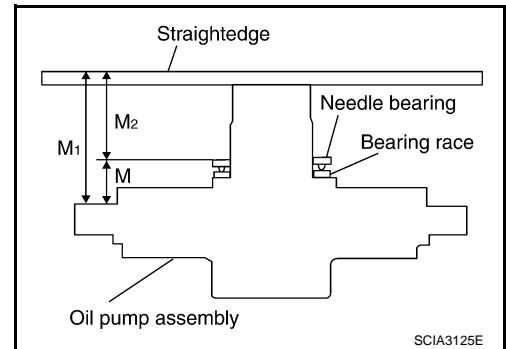

3. Adjust total end play "T1".

$$T_1 = J - M$$

**Total end play "T1"**

$$: 0.25 - 0.55 \text{ mm } (0.0098 - 0.0217 \text{ in})$$

- Select proper thickness of bearing race so that total end play is within specifications. Refer to "Parts Information" for bearing race selection.

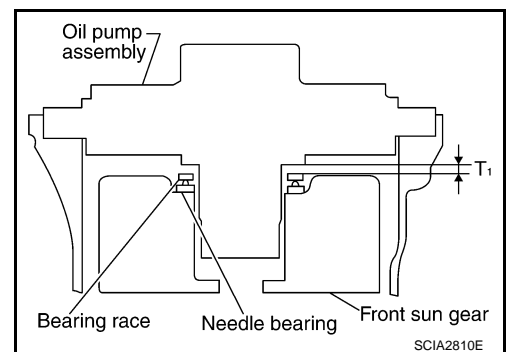

# ASSEMBLY

< SERVICE INFORMATION >

## Assembly (2)

INFOID:000000001327412

1. Install O-ring to oil pump assembly.

**CAUTION:**

- Do not reuse O-ring.
- Apply ATF to O-ring.

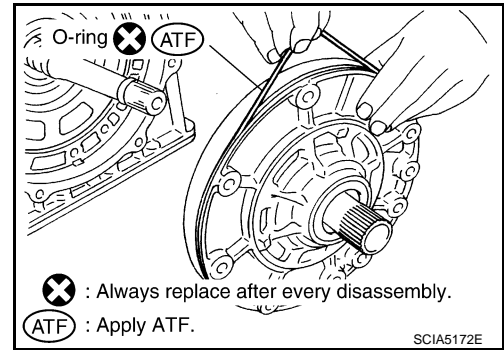

2. Install bearing race to oil pump assembly.

**CAUTION:**

- Apply petroleum jelly to bearing race.

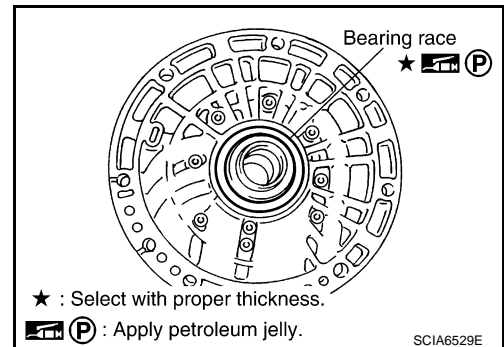

3. Install oil pump assembly in transmission case.

**CAUTION:**

- Apply ATF to oil pump bearing.

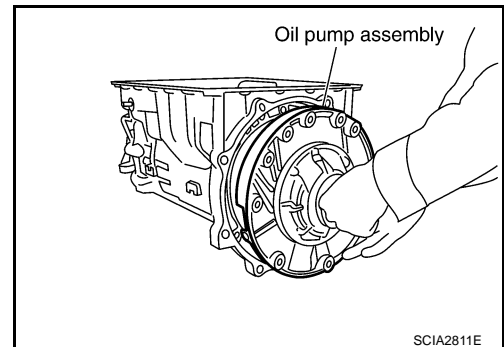

4. Apply recommended sealant (Genuine RTV Silicone Sealant or equivalent. Refer to [GI-44. "Recommended Chemical Product and Sealant"](#).) to oil pump assembly as shown in the figure.

**CAUTION:**

- Completely remove all moisture, oil and old sealant, etc. From the oil pump mounting bolts and oil pump mounting bolt mounting surfaces.

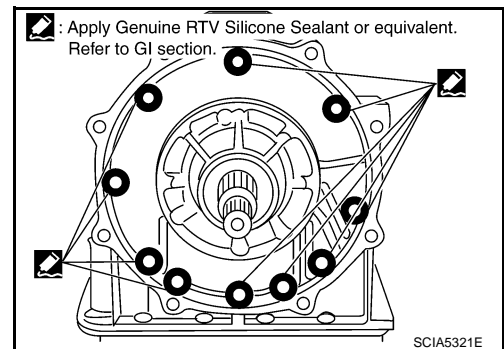

A  
B  
AT  
D  
E  
F  
G  
H  
I  
J  
K  
L  
M  
N  
O  
P

# ASSEMBLY

## < SERVICE INFORMATION >

5. Tighten oil pump mounting bolts to specified torque. Refer to [AT-249, "Component"](#).

**CAUTION:**

Apply ATF to oil pump bushing.

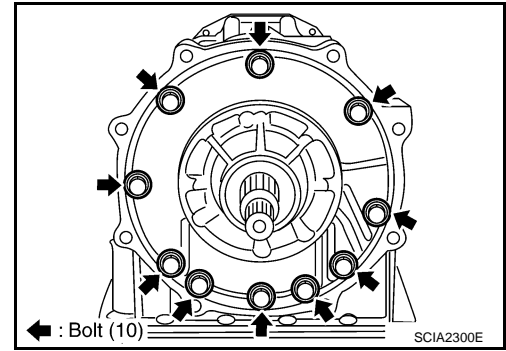

6. Install O-ring to input clutch assembly.

**CAUTION:**

- Do not reuse O-ring.
- Apply ATF to O-ring.

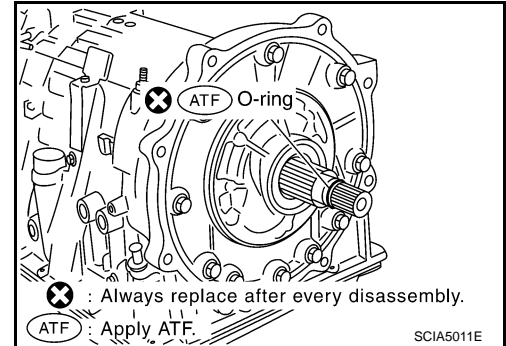

7. Install converter housing to transmission case, and then tighten converter housing mounting bolts (1) to the specified torque. Refer to [AT-249, "Component"](#).

- ← : Bolt (8)

**CAUTION:**

Do not reuse self-sealing bolt (2).

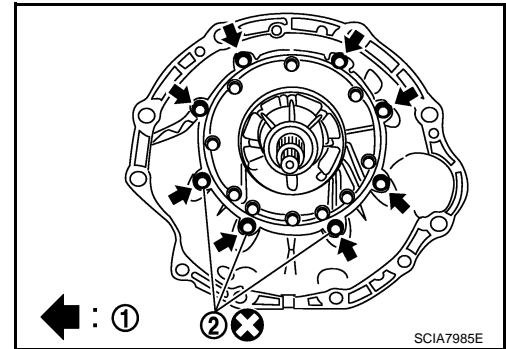

8. Make sure that brake band does not close turbine revolution sensor hole.

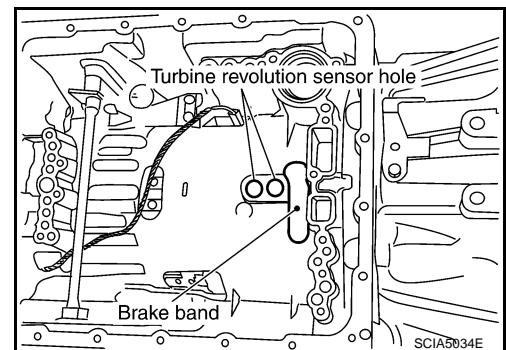

9. Install control valve with TCM.

- a. Connect TCM connector and park/neutral position switch connector.

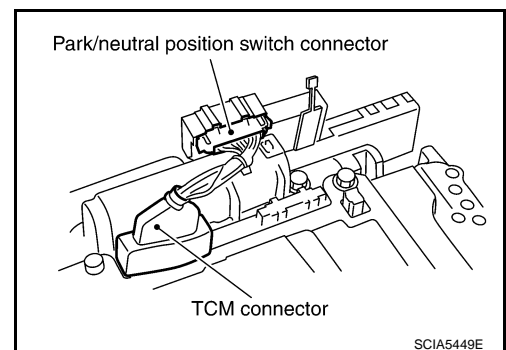

# ASSEMBLY

## < SERVICE INFORMATION >

- b. Install A/T assembly harness connector from control valve with TCM.

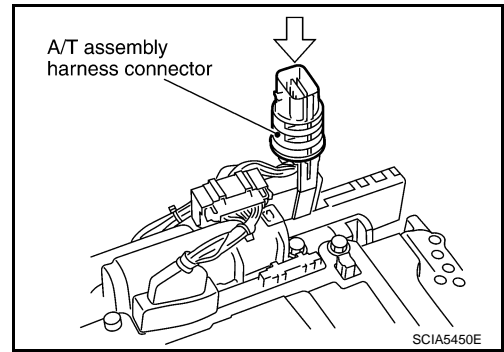

- c. Connect TCM connectors.

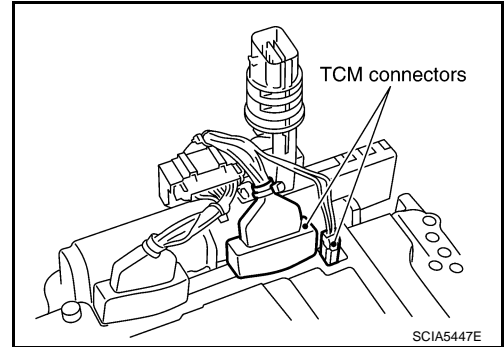

- d. Install O-ring to A/T assembly harness connector.

**CAUTION:**

- Do not reuse O-ring.
- Apply ATF to O-ring.

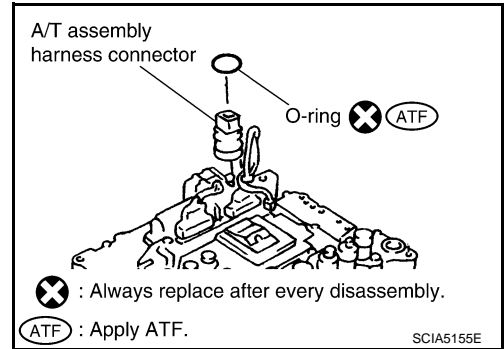

- e. Install A/T fluid temperature sensor 2 to bracket.

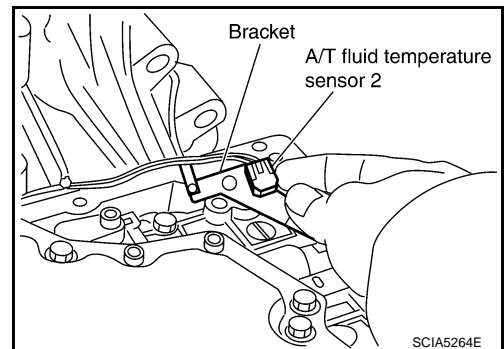

- f. Install A/T fluid temperature sensor 2 (with bracket) in control valve with TCM, and then tighten A/T fluid temperature sensor 2 mounting bolts to the specified torque. Refer to [AT-249, "Component"](#).

**CAUTION:**

**Adjust bolt hole of bracket to bolt hole of control valve.**

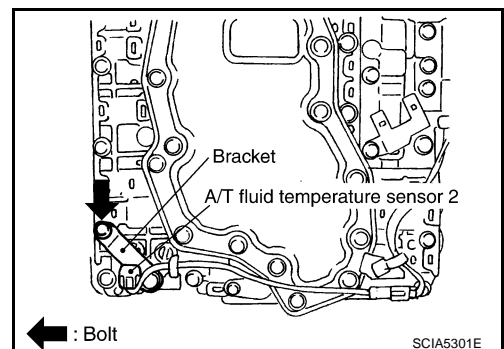

A  
B  
AT  
D  
E  
F  
G  
H  
I  
J  
K  
L  
M  
N  
O  
P

# ASSEMBLY

## < SERVICE INFORMATION >

g. Install control valve with TCM in transmission case.

**CAUTION:**

- Make sure that turbine revolution sensor securely installs turbine revolution sensor hole.
- Hang down revolution sensor harness toward outside so as not to disturb installation of control valve with TCM.
- Adjust A/T assembly harness connector of control valve with TCM to terminal hole of transmission case.

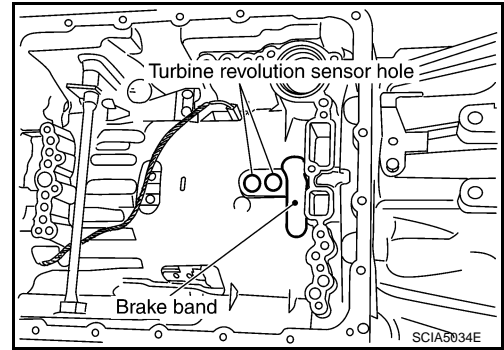

- Assemble it so that manual valve cutout is engaged with manual plate projection.

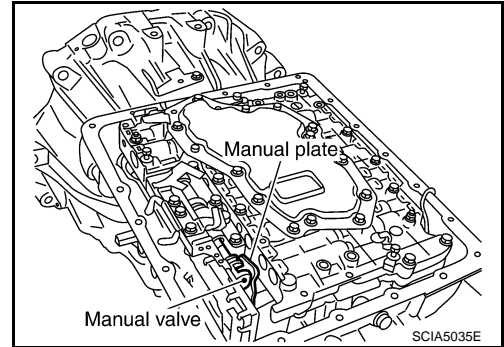

h. Install bolts A, B and C to control valve with TCM.

- ← : Front

Bolt symbol	Length mm (in)	Number of bolts
A	42 (1.65)	5
B	55 (2.17)	6
C	40 (1.57)	1

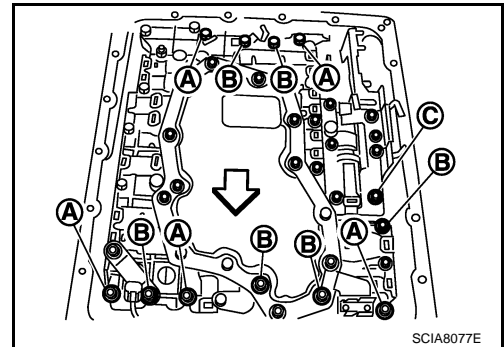

i. Tighten bolt 1, 2 and 3 temporarily to prevent dislocation. After that tighten them in order (1 → 2 → 3), and then tighten other bolts to the specified torque. Refer to [AT-249. "Component"](#).

- ←: Front

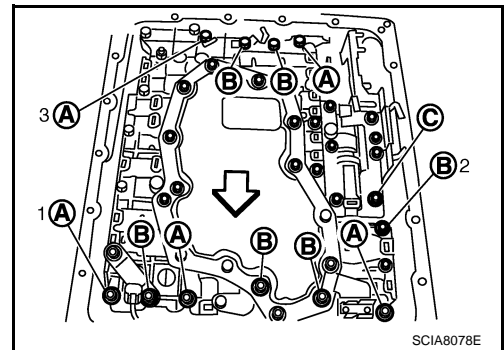

# ASSEMBLY

## < SERVICE INFORMATION >

10. Connect A/T fluid temperature sensor 2 connector (1).
11. Securely fasten terminal cord assembly and A/T fluid temperature sensor 2 harness with terminal clips (←).

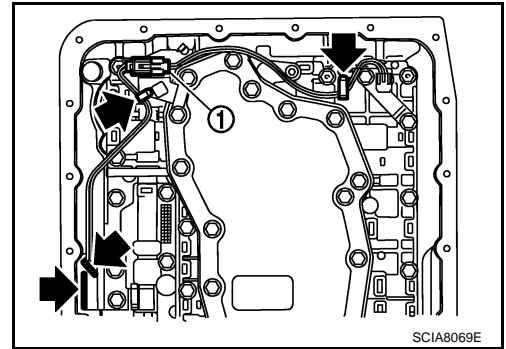

12. Connect revolution sensor connector.

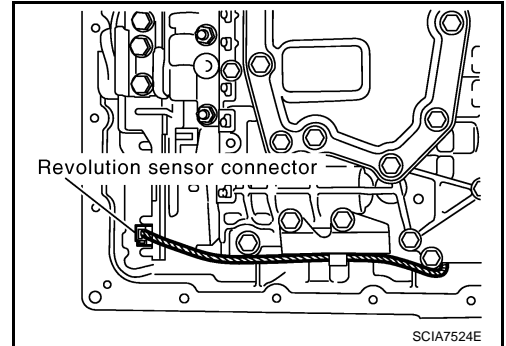

13. Securely fasten revolution sensor 2 harness with terminal clip.

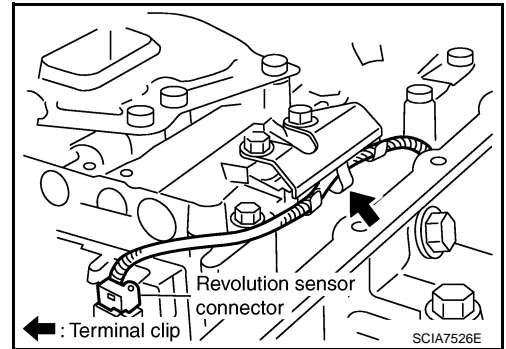

14. Pull down A/T assembly harness connector.  
**CAUTION:**  
Be careful not to damage connector.

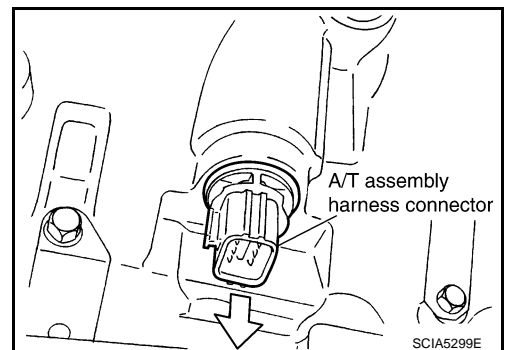

15. Install snap ring to A/T assembly harness connector.

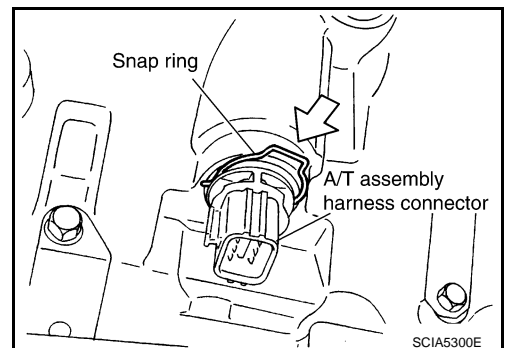

A  
B  
AT  
D  
E  
F  
G  
H  
I  
J  
K  
L  
M  
N  
O  
P

# ASSEMBLY

## < SERVICE INFORMATION >

16. Install magnets in oil pan.

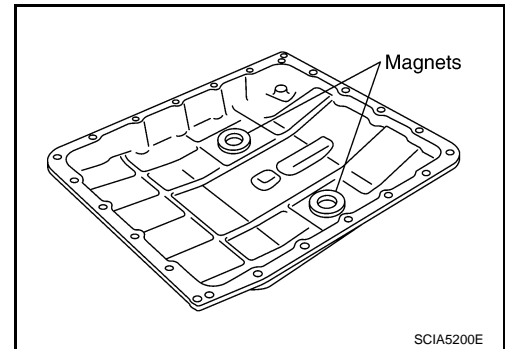

17. Install oil pan to transmission case.

a. Install oil pan gasket to transmission case.

**CAUTION:**

- Do not reuse oil pan gasket.
- Install it in the direction to align hole positions.
- Completely remove all moisture, oil and old gasket, etc. from oil pan gasket mounting surface.

b. Install oil pan (3) (with oil pan gasket), clips (2) and brackets (1) (VK45DE) to transmission case.

- ⇐: Vehicle front
- ←: Bolt (22)

**CAUTION:**

- Install it so that drain plug (4) comes to the position as shown in the figure.
- Be careful not to pinch harnesses.
- Completely remove all moisture, oil and old gasket, etc. from oil pan gasket mounting surface.

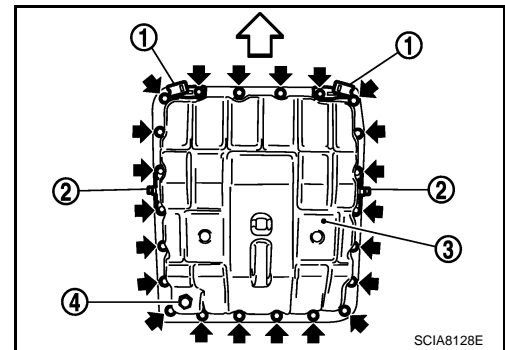

c. Tighten oil pan mounting bolts to the specified torque in numerical order shown in the figure after temporarily tightening them. Refer to [AT-249, "Component"](#).

**CAUTION:**

**Do not reuse oil pan mounting bolts.**

18. Install drain plug to oil pan, and then tighten drain plug mounting bolts to the specified torque. Refer to [AT-249, "Component"](#).

**CAUTION:**

**Do not reuse drain plug gasket.**

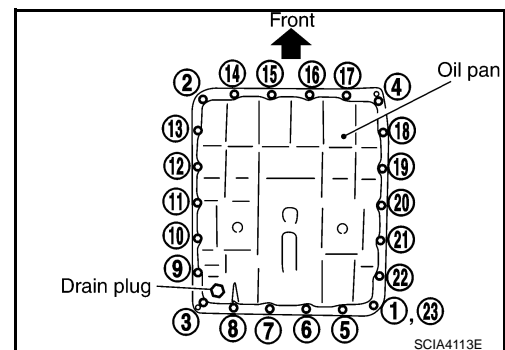

19. Install torque converter.

a. Pour ATF into torque converter.

- Approximately 2 liter (2-1/8 US qt, 1-3/4 Imp qt) of ATF is required for a new torque converter.
- When reusing old torque converter, add the same amount of ATF as was drained.

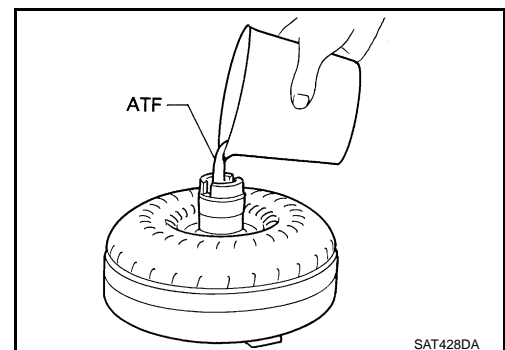



# ASSEMBLY

## < SERVICE INFORMATION >

- b. Install torque converter while aligning notches of torque converter with notches of oil pump.

**CAUTION:**

**Install torque converter while rotating it.**

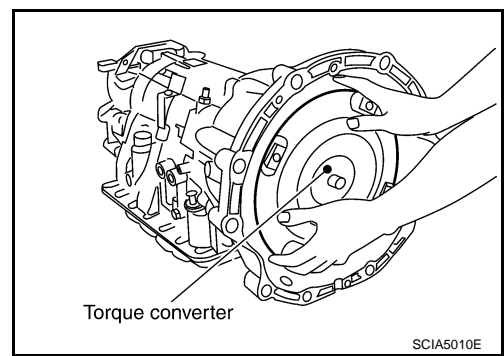

- c. Measure distance "A" to check that torque converter is in proper position.

**Distance "A"**

**VQ35DE models : 25.0 mm (0.98 in) or more**

**VK45DE models : 22.0 mm (0.87 in) or more**

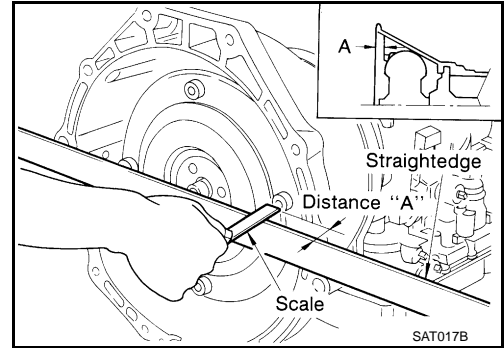

A

B

AT

D

E

F

G

H

I

J

K

L

M

N

O

P

# SERVICE DATA AND SPECIFICATIONS (SDS)

< SERVICE INFORMATION >

## SERVICE DATA AND SPECIFICATIONS (SDS)

### General Specification

INFOID:000000001327413

Applied model	VQ35DE engine		VK45DE engine
	2WD	AWD	
Automatic transmission model	RE5R05A		
Transmission model code number	91X3A	91X3B	96X1C
Stall torque ratio	2.0 : 1		1.85 : 1
Transmission gear ratio	1st	3.540	3.827
	2nd	2.264	2.368
	3rd	1.471	1.520
	4th	1.000	1.000
	5th	0.834	0.834
	Reverse	2.370	2.613
Recommended fluid	Genuine NISSAN Matic J ATF*1		
Fluid capacity	10.3 liter (10-7/8 US qt, 9-1/8 Imp qt)		

**CAUTION:**

- Use only Genuine NISSAN Matic J ATF. Do not mix with other ATF.
- Using ATF other than Genuine NISSAN Matic J ATF will deteriorate in driveability and A/T durability, and may damage the A/T, which is not covered by the warranty.

\*1: Refer to [MA-9, "Fluids and Lubricants"](#).

### Vehicle Speed at Which Gear Shifting Occurs

INFOID:000000001327414

#### 2WD MODELS

Engine model	VQ35DE							
	Vehicle speed km/h (MPH)							
Throttle position	D1→D2	D2→D3	D3→D4	D4→D5	D5→D4	D4→D3	D3→D2	D2→D1
Full throttle	68 - 72 (42 - 45)	106 - 114 (66 - 71)	164 - 174 (102 - 108)	235 - 245 (146 - 152)	231 - 241 (144 - 150)	144 - 154 (89 - 96)	89 - 97 (55 - 60)	43 - 47 (27 - 29)
Half throttle	54 - 58 (34 - 36)	84 - 90 (52 - 56)	127 - 135 (79 - 84)	159 - 167 (99 - 104)	104 - 112 (65 - 70)	75 - 83 (47 - 52)	35 - 41 (22 - 25)	11 - 15 (7 - 9)

- At half throttle, the accelerator opening is 4/8 of the full opening.

#### AWD MODELS

Engine model	VQ35DE							
	Vehicle speed km/h (MPH)							
Throttle position	D1→D2	D2→D3	D3→D4	D4→D5	D5→D4	D4→D3	D3→D2	D2→D1
Full throttle	62 - 66 (39 - 41)	96 - 104 (60 - 65)	149 - 159 (93 - 99)	213 - 223 (132 - 139)	209 - 219 (130 - 136)	131 - 141 (81 - 88)	81 - 89 (50 - 55)	39 - 43 (24 - 27)
Half throttle	49 - 53 (30 - 33)	76 - 82 (47 - 51)	115 - 123 (71 - 76)	144 - 152 (89 - 94)	95 - 103 (59 - 64)	67 - 75 (42 - 47)	32 - 38 (20 - 24)	11 - 15 (7 - 9)

- At half throttle, the accelerator opening is 4/8 of the full opening.

Engine model	VK45DE							
	Vehicle speed km/h (MPH)							
Throttle position	D1→D2	D2→D3	D3→D4	D4→D5	D5→D4	D4→D3	D3→D2	D2→D1

# SERVICE DATA AND SPECIFICATIONS (SDS)

## < SERVICE INFORMATION >

Full throttle	59 - 63 (37 - 39)	95 - 103 (59 - 64)	147 - 157 (92 - 98)	219 - 229 (137 - 143)	215 - 225 (134 - 141)	130 - 140 (81 - 88)	82 - 90 (51 - 56)	35 - 39 (22 - 24)
Half throttle	48 - 52 (30 - 33)	78 - 84 (48 - 52)	122 - 130 (76 - 81)	154 - 162 (96 - 101)	122 - 130 (76 - 81)	68 - 76 (42 - 47)	40 - 46 (25 - 29)	9 - 13 (6 - 8)

- At half throttle, the accelerator opening is 4/8 of the full opening.

## Vehicle Speed at Which Lock-up Occurs/Releases

INFOID:000000001327415

### 2WD MODELS

Engine model	VQ35DE	
Throttle position	Vehicle speed km/h (MPH)	
	Lock-up ON	Lock-up OFF
Closed throttle	65 - 73 (40 - 45)	62 - 70 (39 - 43)
Half throttle	196 - 204 (122 - 127)	153 - 161 (95 - 100)

- At closed throttle, the accelerator opening is less than 1/8 condition. (Closed throttle position signal: OFF)
- At half throttle, the accelerator opening is 4/8 of the full opening.

### AWD MODELS

Engine model	VQ35DE	
Throttle position	Vehicle speed km/h (MPH)	
	Lock-up ON	Lock-up OFF
Closed throttle	59 - 67 (37 - 42)	56 - 64 (35 - 40)
Half throttle	178 - 186 (111 - 116)	139 - 147 (86 - 91)

- At closed throttle, the accelerator opening is less than 1/8 condition. (Closed throttle position signal: OFF)
- At half throttle, the accelerator opening is 4/8 of the full opening.

Engine model	VK45DE	
Throttle position	Vehicle speed km/h (MPH)	
	Lock-up ON	Lock-up OFF
Closed throttle	66 - 74 (41 - 46)	53 - 61 (33 - 38)
Half throttle	191 - 199 (119 - 124)	145 - 153 (90 - 95)

- At closed throttle, the accelerator opening is less than 1/8 condition. (Closed throttle position signal: OFF)
- At half throttle, the accelerator opening is 4/8 of the full opening.

## Stall Speed

INFOID:000000001327416

Engine model	VQ35DE	VK45DE
Stall speed	2,650 - 2,950 rpm	2,260 - 2,560 rpm

## Line Pressure

INFOID:000000001327417

Engine speed	Line pressure kPa (kg/cm <sup>2</sup> , psi)	
	"R" position	"D" and "M" positions
At idle speed	425 - 465 (4.3 - 4.7, 62 - 67)	379 - 428 (3.9 - 4.4, 55 - 62)
At stall speed	1,605 - 1,950 (16.4 - 19.9, 233 - 283)	1,310 - 1,500 (13.4 - 15.3, 190 - 218)

# SERVICE DATA AND SPECIFICATIONS (SDS)

## < SERVICE INFORMATION >

### A/T Fluid Temperature Sensor

INFOID:000000001327418

Name	Condition	CONSULT-III "DATA MONITOR" (Approx.)	Resistance (Approx.)
A/T fluid temperature sensor 1	0°C (32°F)	3.3 V	15 kΩ
	20°C (68°F)	2.7 V	6.5 kΩ
	80°C (176°F)	0.9 V	0.9 kΩ
A/T fluid temperature sensor 2	0°C (32°F)	3.3 V	10 kΩ
	20°C (68°F)	2.5 V	4 kΩ
	80°C (176°F)	0.7 V	0.5 kΩ

### Turbine Revolution Sensor

INFOID:000000001327419

Name	Condition	Data (Approx.)
Turbine revolution sensor 1	When running at 50 km/h (31 MPH) in 4th speed with the closed throttle position signal OFF.	1.3 kHz
Turbine revolution sensor 2	When moving at 20 km/h (12 MPH) in 1st speed with the closed throttle position signal OFF.	

### Vehicle Speed Sensor A/T (Revolution Sensor)

INFOID:000000001327420

Name	Condition	Data (Approx.)
Revolution sensor	When moving at 20 km/h (12 MPH).	185 Hz

### Reverse Brake

INFOID:000000001327421

Model code number	91X3A, 91X3B	96X1C
Number of drive plates	6	
Number of driven plates	6	
Clearance mm (in)	Standard	0.7 - 1.1 (0.028 - 0.043)

### Total End Play

INFOID:000000001327422

Total end play mm (in)	0.25 - 0.55 (0.0098 - 0.0217)
------------------------	-------------------------------