

SECTION **RSU**
 REAR SUSPENSION

A
B
C
D

RSU

CONTENTS

PRECAUTIONS	2	SUSPENSION ARM	11	F
Cautions	2	Removal and Installation	11	
PREPARATION	3	REMOVAL	11	G
Special Service Tools (SST)	3	INSPECTION AFTER REMOVAL	11	
Commercial Service Tools	3	INSTALLATION	12	
NOISE, VIBRATION AND HARSHNESS (NVH)		RADIUS ROD	13	H
TROUBLESHOOTING	4	Removal and Installation	13	
NVH Troubleshooting Chart	4	REMOVAL	13	
REAR SUSPENSION ASSEMBLY	5	INSPECTION AFTER REMOVAL	13	I
On-Vehicle Inspection and Service	5	INSTALLATION	13	
INSPECTION OF BALL JOINT END PLAY	5	FRONT LOWER LINK	14	J
SHOCK ABSORBER INSPECTION	5	Removal and Installation	14	
Wheel Alignment Inspection	5	REMOVAL	14	
DESCRIPTION	5	INSPECTION AFTER REMOVAL	14	
PRELIMINARY INSPECTION	5	INSTALLATION	14	
GENERAL INFORMATION AND RECOMMEN-		REAR LOWER LINK & COIL SPRING	15	K
DATIONS	5	Removal and Installation	15	
THE ALIGNMENT PROCESS	6	REMOVAL	15	
CAMBER INSPECTION	6	INSPECTION AFTER REMOVAL	15	
TOE-IN	6	INSTALLATION	15	
Removal and installation	7	STABILIZER BAR	16	L
COMPONENTS	7	Removal and Installation	16	
REMOVAL	8	REMOVAL	16	
INSTALLATION	8	INSPECTION AFTER REMOVAL	16	
SHOCK ABSORBER	9	INSTALLATION	16	M
Removal and Installation	9	REAR SUSPENSION MEMBER	17	
REMOVAL	9	Removal and Installation	17	
INSPECTION AFTER REMOVAL	9	REMOVAL	17	
INSTALLATION	9	INSPECTION AFTER REMOVAL	17	
Disassembly and Assembly	9	INSTALLATION	17	
DISASSEMBLY	9	SERVICE DATA AND SPECIFICATIONS (SDS)	18	
INSPECTION AFTER DISASSEMBLY	10	Wheel Alignment (Unladen*)	18	
ASSEMBLY	10	Ball Joint	18	
		Wheelarch Height (Unladen*)	18	

PRECAUTIONS

PRECAUTIONS

PFP:00001

Cautions

NES000G0

- When installing rubber bushings, final tightening must be carried out under unladen conditions with tires on level ground. Oil will shorten the life of rubber bushings. Be sure to wipe off any spilled oil.
- Unladen conditions means that fuel, engine coolant and lubricant are full. Spare tire, jack, hand tools and mats are in designated positions.
- After servicing suspension parts, be sure to check wheel alignment.
- Caulking nuts are not reusable. Always use new ones when installing. Since new caulking nuts are pre-oiled, tighten as they are.

PREPARATION

PREPARATION

PPF:00002

Special Service Tools (SST)

NES000G1

The actual shapes of Kent-Moore tools may differ from those of special service tools illustrated here.

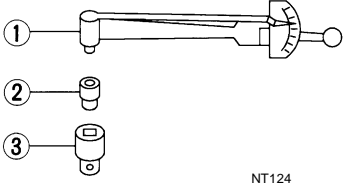
Tool number (Kent-Moore No.) Tool name	Description
ST3127S000 (See J-25742-1) Preload gauge 1. GG91030000 Torque wrench (J-25765) 2. HT62940000 (—) Socket adapter (1/2") 3. HT62900000 (—) Socket adapter (3/8")	 <p>Measuring rotating torque of ball joint</p>

Commercial Service Tools

NES000G2

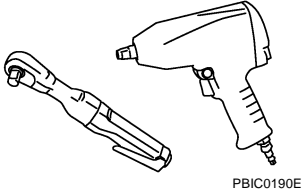
Tool name	Description
Power tool	 <ul style="list-style-type: none"> ● Removing wheel nuts ● Removing brake caliper assembly ● Removing rear suspension component parts

NOISE, VIBRATION AND HARSHNESS (NVH) TROUBLESHOOTING

NOISE, VIBRATION AND HARSHNESS (NVH) TROUBLESHOOTING

PFP:00003

NVH Troubleshooting Chart

NES000G3

Use chart below to help you find the cause of the symptom. If necessary, repair or replace these parts.

Symptom		REAR SUSPENSION	Possible cause and SUSPECTED PARTS													Reference page			
			Improper installation, looseness	Shock absorber deformation, damage or deflection	Bushing or mounting deterioration	Parts interference	Spring fatigue	Suspension looseness	Incorrect wheel alignment	Stabilizer bar fatigue	PROPELLER SHAFT	DIFFERENTIAL	REAR AXLE AND REAR SUSPENSION	TIRES	ROAD WHEEL		DRIVE SHAFT	BRAKES	STEERING
Noise	REAR SUSPENSION	Noise	x	x	x	x	x	x	x			x	x	x	x	x	x	x	RSU-7
		Shake	x	x	x	x		x			x			x	x	x	x	x	RSU-9
		Vibration	x	x	x	x	x					x		x	x				—
		Shimmy	x	x	x	x			x				x	x	x				—
		Judder	x	x	x								x	x	x				—
		Poor quality ride or handling	x	x	x	x	x		x	x				x	x	x			
																		RSU-5	
																		RSU-16	
																		NVH in PR section	
																		NVH in RFD section	
																		NVH in RAX and RSU section	
																		NVH in WT section	
																		NVH in WT section	
																		NVH in RAX section	
																		NVH in BR section	
																		NVH in PS section	

x: Applicable

REAR SUSPENSION ASSEMBLY

REAR SUSPENSION ASSEMBLY

PFP:55020

On-Vehicle Inspection and Service

NES000HU

Make sure the mounting conditions (looseness, back lash) of each component and component status (wear, damage) are normal.

INSPECTION OF BALL JOINT END PLAY

Measure axial end play by installing and moving up/down with an iron pry bar or something similar between suspension arm and axle.

Standard value

Axial end play : 0 mm (0 in)

CAUTION:

Be careful not to damage ball joint boot.

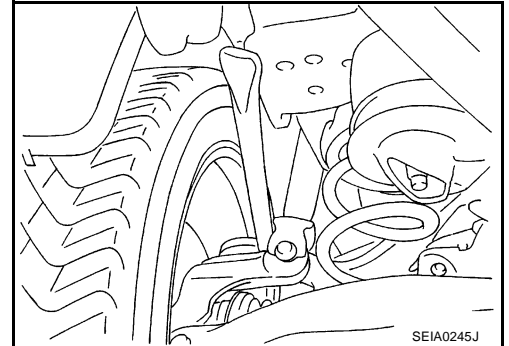

SHOCK ABSORBER INSPECTION

Check shock absorber for oil leakage, damage and replace if necessary.

Wheel Alignment Inspection DESCRIPTION

NES000HV

- Measure wheel alignment under unladen conditions. "Unladen conditions" means that fuel, engine coolant, and lubricant are full. Spare tire, jack, hand tools and mats in designated positions.

PRELIMINARY INSPECTION

- Check tires for improper air pressure and wear.
- Check road wheels for runout.
- Check wheel bearing axial end play.
- Check ball joint axial end play of suspension arm.
- Check shock absorber operation.
- Check each mounting point of axle and suspension for looseness and deformation.
- Check each link, arm and member for cracks, deformation, and other damage.
- Check vehicle posture.

GENERAL INFORMATION AND RECOMMENDATIONS

- A four-wheel thrust alignment should be performed.
 - This type of alignment is recommended for any NISSAN/INFINITI vehicle.
 - The four-wheel "thrust" process helps ensure that the vehicle is properly aligned and the steering wheel is centered.
 - The alignment rack itself should be capable of accepting any NISSAN/INFINITI vehicle.
 - The rack should be checked to ensure that it is level.
- Make sure the machine is properly calibrated.
 - Your alignment equipment should be regularly calibrated in order to give correct information.
 - Check with the manufacturer of your specific equipment for their recommended Service/Calibration Schedule.

REAR SUSPENSION ASSEMBLY

THE ALIGNMENT PROCESS

IMPORTANT:

Use only the alignment specifications listed in this Service Manual.

- When displaying the alignment settings, many alignment machines use “indicators”: (Green/red, plus or minus, Go/No Go). **Do NOT use these indicators.**
- The alignment specifications programmed into your machine that operate these indicators may not be correct.
- This may result in an ERROR.
- Some newer alignment machines are equipped with an optional “Rolling Compensation” method to “compensate” the sensors (alignment targets or head units). **DO NOT use this “Rolling Compensation” method.**
- Use the “Jacking Compensation Method”. After installing the alignment targets or head units, raise the vehicle and rotate the wheels 1/2 turn both ways.
- See Instructions in the alignment machine you're using for more information on this.

CAMBER INSPECTION

- Measure camber of both right and left wheels with a suitable alignment gauge and adjust in accordance with the following procedures.

Standard value

Camber : Refer to [RSU-18, "SERVICE DATA AND SPECIFICATIONS \(SDS\)"](#) .

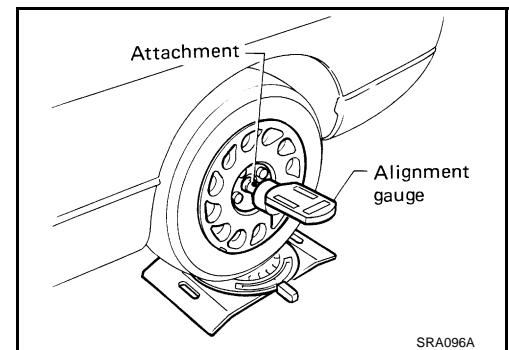

If outside the standard value, adjust with adjusting bolt in front lower link.

NOTE:

After adjusting camber, be sure to check toe-in.

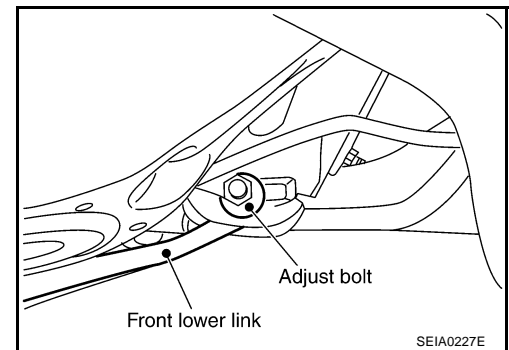

TOE-IN

If toe-in is not within the specification, adjust with adjusting bolt in rear lower link.

CAUTION:

Be sure to adjust equally on RH and LH side with adjusting bolt.

If toe-in is not still within the specification, inspect and replace any damaged or worn rear suspension parts.

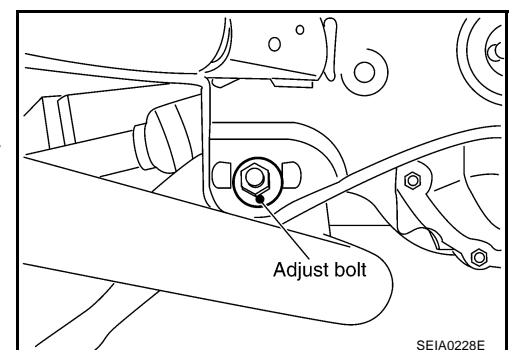

REAR SUSPENSION ASSEMBLY

NES000HY

Removal and installation COMPONENTS

A
B
C
D
E
F
G
H
I
J
K
L
M

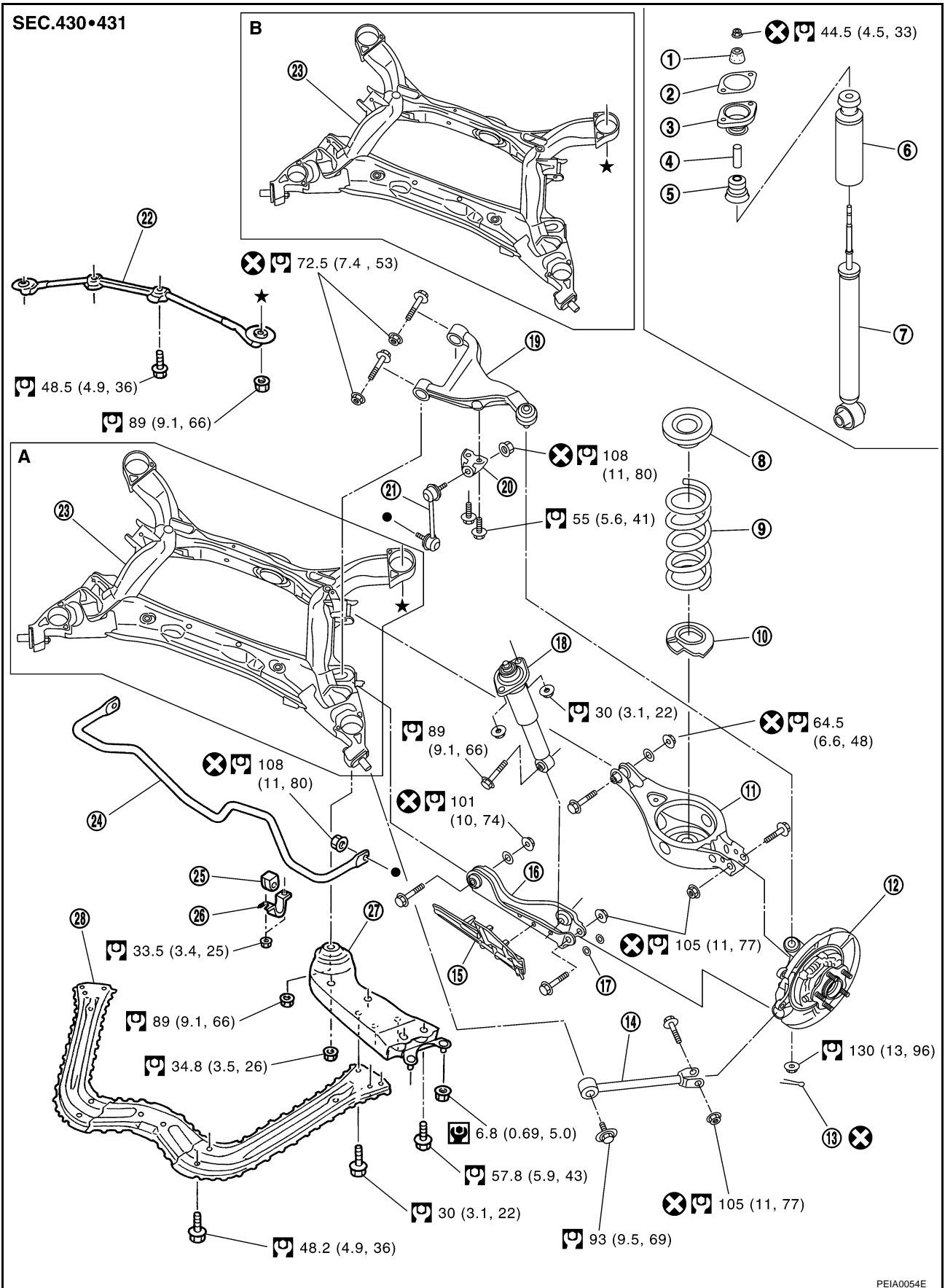

PEIA0054E

REAR SUSPENSION ASSEMBLY

- | | | |
|------------------------|--|--------------------------------|
| 1. Bushing | 2. Mounting seal | 3. Mounting seal bracket |
| 4. Distance tube | 5. Bound bumper cover | 6. Bound bumper |
| 7. Shock absorber | 8. Upper seat | 9. Coil spring |
| 10. Rubber seat | 11. Rear lower link | 12. Axle assembly |
| 13. Cotter pin | 14. Radius rod | 15. Front lower link protector |
| 16. Front lower link | 17. Stopper rubber | 18. Shock absorber assembly |
| 19. Suspension arm | 20. Stabilizer connecting rod mounting bracket | 21. Stabilizer connecting rod |
| 22. Rear pin stay | 23. Rear suspension member | 24. Stabilizer bar |
| 25. Stabilizer bushing | 26. Stabilizer clamp | 27. Member stay |
| 28. Tunnel stay | A: With height sensor | B: Without height sensor |

Refer to [GI-11, "Components"](#) , for the symbols in the figure.

REMOVAL

1. Remove tires from vehicle with power tool.
2. Remove brake caliper with power tool. Hang it in a place where it will not interfere with work. Refer to [BR-25, "REAR DISC BRAKE"](#) .

NOTE:

Avoid depressing brake pedal while brake caliper is removed.

3. Remove wheel sensor from rear final drive, then remove wheel sensor harness from rear suspension member.
4. Remove height sensor harness from rear suspension member (if equipped).
5. Remove center muffler and main muffler. Refer to [EX-3, "Components"](#) .
6. Remove stabilizer bar. Refer to [RSU-16, "Removal and Installation"](#) .
7. Remove rear propeller shaft. Refer to [PR-9, "Removal and Installation"](#) .
8. Separate attachments between parking brake cable and vehicle and rear suspension member.
9. Remove rear lower link and coil spring. Refer to [RSU-15, "Removal and Installation"](#) .
10. Remove fixing bolt in lower side of shock absorber with power tool.
11. Set jack under rear final drive.
12. Remove fixing bolts and nuts of tunnel stay and member stay with power tool, then remove those parts from vehicle.
13. Remove fixing bolts and nuts of rear pin stay with power tool and then remove rear pin stay from vehicle.
14. Gradually lowering jack, remove rear suspension assembly.

INSTALLATION

- Refer to [RSU-7, "Removal and installation"](#) for tightening torque. Install in the reverse order of removal.

NOTE:

Refer to component parts location and do not reuse non-reusable parts.

- Perform final tightening of installation position of links (rubber bushing) under unladen conditions with tires on level ground. Check wheel alignment. Refer to [RSU-5, "Wheel Alignment Inspection"](#) .
- After adjusting wheel alignment, adjust neutral position of steering angle sensor. Refer to [BRC-6, "Adjustment of Steering Angle Sensor Neutral Position"](#) .

SHOCK ABSORBER

SHOCK ABSORBER

PF:56210

Removal and Installation

NES000G8

REMOVAL

1. Remove tires from vehicle with power tool.
2. Set jack under rear lower link.
3. Remove fixing bolt in lower side of shock absorber assembly with power tool.
4. Remove fixing nuts in upper side of shock absorber assembly with power tool and remove shock absorber assembly from vehicle.

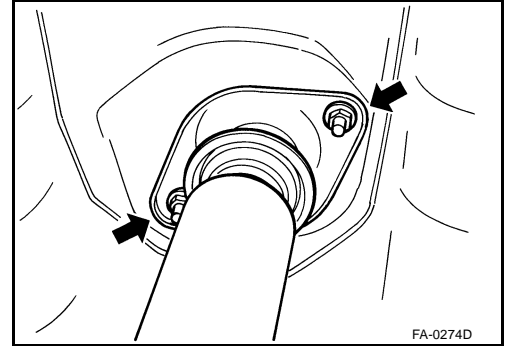

INSPECTION AFTER REMOVAL

- Check shock absorber assembly for deformation, cracks, or damage, and replace if necessary.
- Check piston rod for damage, uneven wear, or distortion, and replace if necessary.
- Check welded and sealed areas for oil leakage, and replace if necessary.

INSTALLATION

- Refer to [RSU-7, "Removal and installation"](#) for tightening torque. Install in the reverse order of removal.

NOTE:

Refer to component parts location and do not reuse non-reusable parts.

- Perform final tightening of shock absorber assembly lower side (rubber bushing) under unladen conditions with tires on level ground. Check wheel alignment. Refer to [RSU-5, "Wheel Alignment Inspection"](#).
- After adjusting wheel alignment, adjust neutral position of steering angle sensor. Refer to [BRC-6, "Adjustment of Steering Angle Sensor Neutral Position"](#).

Disassembly and Assembly

NES000G9

DISASSEMBLY

CAUTION:

Make sure piston rod on shock absorber is not damaged when removing components from shock absorber.

1. Remove mounting seal from mounting seal bracket.
2. Wrap a shop cloth around lower side of shock absorber and fix it in a vise.

CAUTION:

Do not set the cylindrical part of shock absorber in vise.

3. Fix piston rod with hexagon wrench, and remove piston rod lock nut.
4. Remove mounting seal bracket, bushing, distance tube, bound bumper cover and bound bumper from shock absorber.

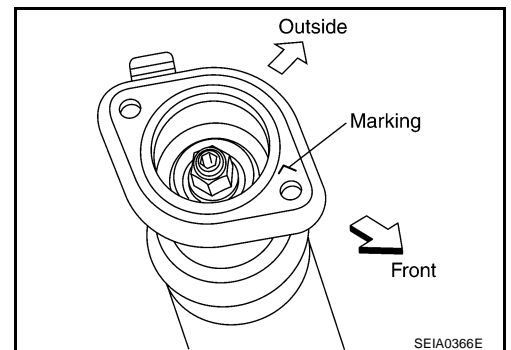

SHOCK ABSORBER

INSPECTION AFTER DISASSEMBLY

Bound Bumper and Bushing

Check bound bumper and bushing for cracks, deformation or other damage. Replace if necessary.

ASSEMBLY

- Refer to [RSU-7, "Removal and installation"](#) for tightening torque. Assembly in the reverse order of disassembly.

NOTE:

- Refer to component parts location and do not reuse non-reusable parts.
- Make sure piston rod on shock absorber is not damaged when attaching components to shock absorber.

SUSPENSION ARM

SUSPENSION ARM

PFP:55501

Removal and Installation

NES000GA

REMOVAL

1. Remove tires from vehicle with power tool.
2. Remove stabilizer connecting rod mounting bracket from suspension arm with power tool.
3. Remove drive shaft from vehicle. (VK45DE models) Refer to [RAX-9, "Removal and Installation"](#).
4. Remove cotter pin of suspension arm ball joint, and loosen nut.
5. Use a ball joint remover (suitable tool) to remove suspension arm from axle assembly. Be careful not to damage ball joint boot.

CAUTION:

Tighten temporarily mounting nut to prevent damage to threads and to prevent ball joint remover (suitable tool) from coming off.

6. Remove fixing nuts and bolts between suspension arm and rear suspension member with power tool.
7. Remove suspension arm from vehicle.

INSPECTION AFTER REMOVAL

Visual Inspection

- Check suspension arm and bushing for deformation, cracks, or damage. If any non-standard condition is found, replace it.
- Check boot of ball joint for cracks, or damage, and also for grease leakage.

Ball Joint Inspection

Manually move ball stud to confirm it moves smoothly with no binding.

Swing Torque Inspection

NOTE:

Before measuring, move ball joint at least ten times by hand to check for smooth movement.

- Hook a spring balance at cotter pin mounting hole. Confirm spring balance measurement value is within the specifications when ball stud begins moving.

Swing torque:

0.5 – 3.4 N·m (0.06 – 0.34 kg·m, 5 – 30 in·lb)

Measured value of spring scale:

9.7 – 66.0 N (0.99 – 6.7 kg, 2.18 – 14.8 lb)

- If it is outside the specified range, replace suspension arm assembly.

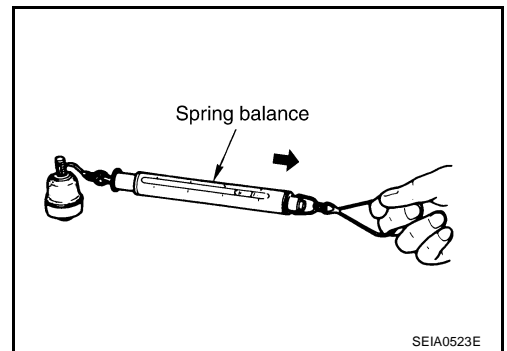

Rotating Torque Inspection

- Attach mounting nut to ball stud. Make sure rotating torque is within the specifications with a preload gauge (SST).

Rotating torque:

0.5 – 3.4 N·m (0.06 – 0.34 kg·m, 5 - 30 in·lb)

- If it is outside the specified range, replace suspension arm assembly.

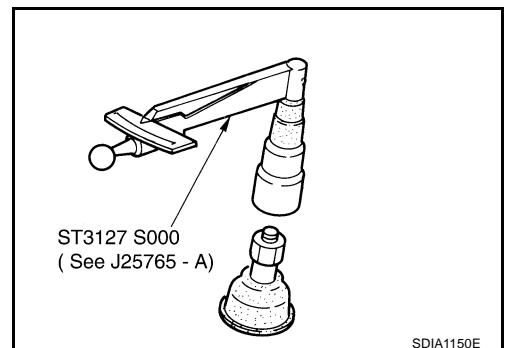

Axial End Play Inspection

- Move tip of ball joint in axial direction to check for looseness.

Axial end play : 0 mm (0 in)

- If it is outside the specified range, replace suspension arm assembly.

SUSPENSION ARM

INSTALLATION

- Refer to [RSU-7, "Removal and installation"](#) for tightening torque. Install in the reverse order of removal.

NOTE:

Refer to component parts location and do not reuse non-reusable parts.

- Perform final tightening of rear suspension member installation position (rubber bushing) under unladen conditions with tires on level ground. Check wheel alignment. Refer to [RSU-5, "Wheel Alignment Inspection"](#) .
- After adjusting wheel alignment, adjust neutral position of steering angle sensor. Refer to [BRC-6, "Adjustment of Steering Angle Sensor Neutral Position"](#) .

RADIUS ROD

RADIUS ROD

PFP:55110

Removal and Installation

NES000GB

REMOVAL

1. Remove tires from vehicle with power tool. A
2. Set jack under rear lower link. B
3. Remove fixing bolt and nut in axle side of radius rod. C
4. Remove fixing bolt in rear suspension member side of radius rod with power tool, then remove radius rod from vehicle. C

INSPECTION AFTER REMOVAL

Check radius rod and bushing for any deformation, cracks, or damage. Replace if necessary. D

INSTALLATION

- Refer to [RSU-7, "Removal and installation"](#) for tightening torque. Install in the reverse order of removal. RSU
- NOTE:**
Refer to component parts location and do not reuse non-reusable parts.
- Perform final tightening of rear suspension member and axle installation position (rubber bushing) under unladen conditions with tires on level ground. Check wheel alignment. Refer to [RSU-5, "Wheel Alignment Inspection"](#) . F
 - After adjusting wheel alignment, adjust neutral position of steering angle sensor. Refer to [BRC-6, "Adjustment of Steering Angle Sensor Neutral Position"](#) . G

H

I

J

K

L

M

FRONT LOWER LINK

PFP:55110

Removal and Installation

NES000GC

REMOVAL

1. Remove tires from vehicle with power tool.
2. Set jack under rear lower link.
3. Remove front lower link protector.
4. Remove shock absorber assembly from vehicle. Refer to [RSU-9, "Removal and Installation"](#) .
5. Remove fixing nut and bolt between front lower link and axle with power tool.
6. Remove fixing nut and bolt between front lower link and rear suspension member with power tool.
7. Remove front lower link from vehicle.

INSPECTION AFTER REMOVAL

Check front lower link and bushing for any deformation, crack, or damage. Replace if necessary.

INSTALLATION

- Refer to [RSU-7, "Removal and installation"](#) for tightening torque. Install in the reverse order of removal.

NOTE:

Refer to component parts location and do not reuse non-reusable parts.

- Perform final tightening of rear suspension member and axle installation position (rubber bushing) under unladen conditions with tires on level ground. Check wheel alignment. Refer to [RSU-5, "Wheel Alignment Inspection"](#) .
- After adjusting wheel alignment, adjust neutral position of steering angle sensor. Refer to [BRC-6, "Adjustment of Steering Angle Sensor Neutral Position"](#) .

REAR LOWER LINK & COIL SPRING

REAR LOWER LINK & COIL SPRING

PF5:551B0

Removal and Installation

REMOVAL

1. Remove tire with power tool.
2. Set jack under rear lower link.
3. Loosen fixing bolt and nut between rear lower link and suspension member, and then remove fixing bolt and nut between rear axle and rear lower link with power tool.
4. Slowly lower jack, then remove upper seat, coil spring and rubber seat from rear lower link.
5. Remove fixing bolt and nut between rear suspension member and rear lower link with power tool.

INSPECTION AFTER REMOVAL

- Check rear lower link, bushing and coil spring for deformation, cracks, and damage. Replace rear lower link and coil spring if necessary.

INSTALLATION

- Refer to [RSU-7, "COMPONENTS"](#) for tightening torque. Install in the reverse order of removal.

CAUTION:

Refer to component parts location and do not reuse non-reusable parts.

- Make sure upper seat is attached as shown in the figure.

NOTE:

Insert bracket tabs (3) and the inside protrusion on upper seat into each other beforehand as shown in the figure.

- Match up rubber seat indentions and rear lower link grooves and attach.

NOTE:

Make sure spring is not upside down. The top and bottom are indicated by paint color.

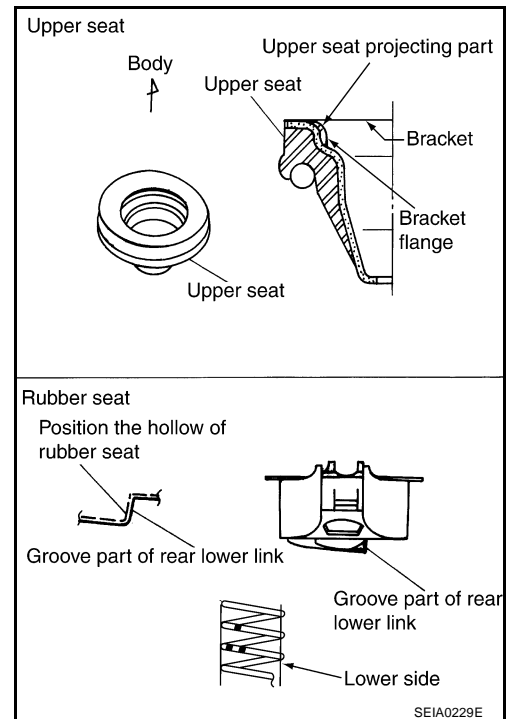

- Perform final tightening of rear suspension member and axle installation position (rubber bushing) under unladen conditions with tires on level ground. Check wheel alignment. Refer to [RSU-5, "Wheel Alignment Inspection"](#).

STABILIZER BAR

STABILIZER BAR

PFP:56230

Removal and Installation

NES000GE

REMOVAL

1. Remove tires from vehicle with power tool.
2. Remove center muffler from vehicle. Refer to [EX-3, "Components"](#) .
3. Remove fixing bolts and remove stabilizer connecting rod mount bracket from suspension arm with power tool.
4. Remove lower side fixing nut on stabilizer connecting rod and remove stabilizer connecting rod from stabilizer bar with power tool.
5. Remove fixing nuts on stabilizer clamps and remove stabilizer from vehicle with power tool.

INSPECTION AFTER REMOVAL

Check stabilizer bar, stabilizer bushings, stabilizer clamps, stabilizer connecting rod, stabilizer connecting rod mounting bracket for any deformation, cracks or damage. Replace if necessary.

INSTALLATION

- Refer to [RSU-7, "Removal and installation"](#) for tightening torque. Install in the reverse order of removal.

NOTE:

Refer to component parts location and do not reuse non-reusable parts.

- Stabilizer bar uses pillow ball type connecting rod, position ball joint with case on pillow ball head parallel to stabilizer bar.
- When the bushing and clamp are installed to stabilizer bar, position the bushing and clamp inside of the side slip prevention clamp.

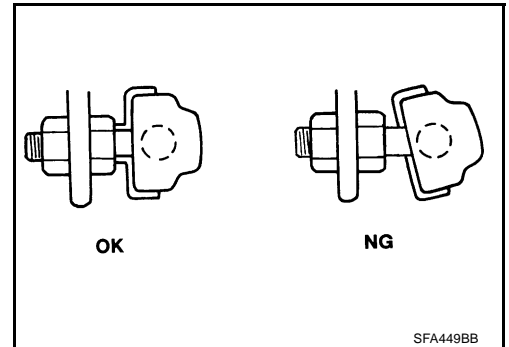

REAR SUSPENSION MEMBER

REAR SUSPENSION MEMBER

PFP:55501

Removal and Installation

NES000GF

REMOVAL

1. Remove tires from vehicle with power tool.
 2. Remove brake caliper with power tool. Hang it in a place where it will not interfere with work. Refer to [BR-25, "REAR DISC BRAKE"](#).
- NOTE:**
Avoid depressing brake pedal while brake caliper is removed.
3. Remove wheel sensor from rear final drive, then remove wheel sensor harness from rear suspension member. Refer to [BRC-55, "WHEEL SENSORS"](#).
 4. Remove height sensor harness from rear suspension member (if equipped).
 5. Remove center muffler and main muffler. Refer to [EX-3, "EXHAUST SYSTEM"](#).
 6. Remove stabilizer bar. Refer to [RSU-16, "Removal and Installation"](#).
 7. Remove rear drive shaft. Refer to [RAX-9, "REAR DRIVE SHAFT"](#).
 8. Remove propeller shaft. Refer to [PR-7, "REAR PROPELLER SHAFT"](#).
 9. Remove rear final drive. Refer to [RFD-16, "Removal and Installation"](#).
 10. Separate attachments between parking brake cable and vehicle and rear suspension member. Refer to [PB-4, "PARKING BRAKE CONTROL"](#).
 11. Remove rear lower link and coil spring. Refer to [RSU-15, "Removal and Installation"](#).
 12. Remove fixing bolt in lower side of shock absorber with power tool.
 13. Set jack under rear suspension member.
 14. Remove fixing bolts and nuts of tunnel stay and member stay with power tool, then remove those parts from vehicle and rear suspension member.
 15. Remove fixing bolts and nuts of rear pin stay with power tool and then remove rear pin stay from vehicle and rear suspension member.
 16. Slowly lowering jack, then remove rear suspension member, suspension arm, radius rod, front lower link and axle from vehicle as a unit.
 17. Remove fixing bolts and nuts with power tool, then remove suspension arm, front lower link, and radius rod from rear suspension member.

INSPECTION AFTER REMOVAL

Check rear suspension member for deformation, cracks, and other damage and replace if necessary.

INSTALLATION

- Refer to [RSU-7, "Removal and installation"](#), for tightening torque. Install in the reverse order of removal.
- NOTE:**
Refer to component parts location and do not reuse non-reusable parts.
- Perform final tightening of installation position of links (rubber bushing) under unladen conditions with tires on level ground. Check wheel alignment. Refer to [RSU-5, "Wheel Alignment Inspection"](#).
 - After adjusting wheel alignment, adjust neutral position of steering angle sensor. Refer to [BRC-6, "Adjustment of Steering Angle Sensor Neutral Position"](#).

SERVICE DATA AND SPECIFICATIONS (SDS)

SERVICE DATA AND SPECIFICATIONS (SDS)

PFP:00030

Wheel Alignment (Unladen*)

NES000LV

Camber Degree minute (Decimal degree)		Minimum	-1° 18' (-1.30°)
		Nominal	-0° 48' (-0.80°)
		Maximum	-0° 18' (-0.30°)
Total toe-in	Distance	Minimum	2.4 mm (0.09 in)
		Nominal	4.7 mm (0.19 in)
		Maximum	7.0 mm (0.28 in)
	Angle (left wheel or right wheel) Degree minute (Decimal degree)	Minimum	0° 05' (0.08°)
		Nominal	0° 10' (0.17°)
		Maximum	0° 15' (0.25°)

*: Fuel, engine coolant and lubricant oil full. Spare tire, jack, hand tools and mats are in designated positions.

Ball Joint

NES000GH

Axial end play	0 mm (0 in)
Swing torque	0.5 – 3.4 N·m (0.06 – 0.34 kg·m, 5 – 30 in·lb)
Measurement on spring balance (cotter pinhole position)	9.7 – 66.0 N (0.99 – 6.7 kg, 2.18 – 14.8 lb)
Rotating torque	0.5 – 3.4 N·m (0.06 – 0.34 kg·m, 5 – 30 in·lb)

Wheelarch Height (Unladen*)

NES000GI

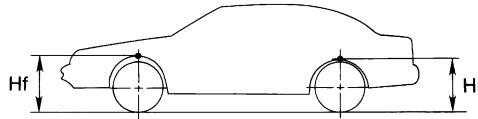

SFA818A

Destination	USA					Canada		
Engine	VQ35DE				VK45DE	VQ35DE		VK45DE
Axle	2WD		AWD			AWD		
Tire size	265/60R18	265/50R20	265/60R18	265/50R20		265/60R18	265/50R20	
Front (Hf)	835 mm (32.87 in)	834 mm (32.83 in)	834 mm (32.83 in)	833 mm (32.80 in)	832 mm (32.76 in)	834 mm (32.83 in)	833 mm (32.80 in)	832 mm (32.76 in)
Rear (Hr)	822 mm (32.36 in)	821 mm (32.32 in)	829 mm (32.64 in)	827 mm (32.56 in)	825 mm (32.48 in)	827 mm (32.56 in)	826 mm (32.52 in)	823 mm (32.40 in)

*: Fuel, engine coolant and engine oil full. Spare tire, jack, hand tools and mats are in designated positions.