

A  
B  
C  
D

# WT

## SECTION

### ROAD WHEELS & TIRES

## CONTENTS

WT

<p><b>PREPARATION</b> ..... 2</p> <p style="padding-left: 20px;">Special Service Tools ..... 2</p> <p style="padding-left: 20px;">Commercial Service Tools ..... 2</p> <p><b>NOISE, VIBRATION AND HARSHNESS (NVH)</b></p> <p><b>TROUBLESHOOTING</b> ..... 3</p> <p style="padding-left: 20px;">NVH Troubleshooting Chart ..... 3</p> <p><b>ROAD WHEEL</b> ..... 4</p> <p style="padding-left: 20px;">Inspection ..... 4</p> <p style="padding-left: 40px;">ALUMINUM WHEEL ..... 4</p> <p style="padding-left: 40px;">STEEL WHEEL ..... 4</p> <p><b>ROAD WHEEL TIRE ASSEMBLY</b> ..... 5</p> <p style="padding-left: 20px;">Balancing Wheels (Bonding Weight Type) ..... 5</p> <p style="padding-left: 40px;">REMOVAL ..... 5</p> <p style="padding-left: 40px;">WHEEL BALANCE ADJUSTMENT ..... 5</p> <p style="padding-left: 20px;">Tire Rotation ..... 6</p> <p><b>LOW TIRE PRESSURE WARNING SYSTEM</b> ..... 7</p> <p style="padding-left: 20px;">System Components ..... 7</p> <p style="padding-left: 20px;">System Description ..... 7</p> <p style="padding-left: 40px;">TRANSMITTER ..... 7</p> <p style="padding-left: 40px;">REMOTE KEYLESS ENTRY RECEIVER ..... 7</p> <p style="padding-left: 40px;">BCM (BODY CONTROL MODULE) ..... 8</p> <p style="padding-left: 40px;">LOW TIRE PRESSURE WARNING LAMP ..... 8</p> <p style="padding-left: 40px;">DISPLAY UNIT ..... 8</p> <p><b>CAN COMMUNICATION</b> ..... 9</p> <p style="padding-left: 20px;">System Description ..... 9</p> <p><b>TROUBLE DIAGNOSES</b> ..... 10</p> <p style="padding-left: 20px;">Schematic ..... 10</p> <p style="padding-left: 20px;">Wiring Diagram ..... 11</p> <p style="padding-left: 20px;">Control Unit Input/Output Signal Standard ..... 14</p> <p style="padding-left: 20px;">ID Registration Procedure ..... 16</p> <p style="padding-left: 40px;">ID REGISTRATION WITH ACTIVATION TOOL.. 16</p> <p style="padding-left: 40px;">ID REGISTRATION WITHOUT ACTIVATION TOOL ..... 17</p> <p style="padding-left: 20px;">Transmitter Wake Up Operation ..... 18</p> <p style="padding-left: 40px;">WITH ACTIVATION TOOL ..... 18</p> <p style="padding-left: 20px;">Self-Diagnosis ..... 19</p> <p style="padding-left: 40px;">DESCRIPTION ..... 19</p> <p style="padding-left: 40px;">FUNCTION ..... 19</p> <p style="padding-left: 40px;">LOW TIRE PRESSURE WARNING LAMP DIAGNOSTIC CHART ..... 19</p>	<p style="padding-left: 20px;">CONSULT-II ..... 20</p> <p style="padding-left: 20px;">WORK SUPPORT MODE ..... 21</p> <p style="padding-left: 20px;">SELF-DIAGNOSTIC RESULTS MODE ..... 21</p> <p style="padding-left: 20px;">DATA MONITOR MODE ..... 22</p> <p style="padding-left: 20px;">ACTIVE TEST MODE ..... 22</p> <p style="padding-left: 20px;">How to Perform Trouble Diagnosis for Quick and Accurate Repair ..... 25</p> <p style="padding-left: 40px;">INTRODUCTION ..... 25</p> <p style="padding-left: 40px;">WORK FLOW ..... 25</p> <p style="padding-left: 20px;">Preliminary Check ..... 26</p> <p style="padding-left: 20px;">Malfunction Code/Symptom Chart ..... 27</p> <p><b>TROUBLE DIAGNOSIS FOR SELF-DIAGNOSTIC ITEMS</b> ..... 28</p> <p style="padding-left: 20px;">Inspection 1: Transmitter or Control Unit (BCM) .... 28</p> <p style="padding-left: 40px;">MALFUNCTION CODE NO. 21, 22, 23 OR 24 ... 28</p> <p style="padding-left: 20px;">Inspection 2: Transmitter - 1 ..... 28</p> <p style="padding-left: 40px;">MALFUNCTION CODE NO. 31, 32, 33, 34, 41, 42, 43, 44, 45, 46, 47 OR 48 ..... 28</p> <p style="padding-left: 20px;">Inspection 3: Transmitter - 2 ..... 29</p> <p style="padding-left: 40px;">MALFUNCTION CODE NO. 35, 36, 37 OR 38 ... 29</p> <p style="padding-left: 20px;">Inspection 4: Vehicle Speed Signal ..... 30</p> <p style="padding-left: 40px;">MALFUNCTION CODE NO. 52 ..... 30</p> <p><b>TROUBLE DIAGNOSIS FOR SYMPTOMS</b> ..... 31</p> <p style="padding-left: 20px;">Inspection 1: Warning Lamp Does Not Come On When Ignition Switch Is Turned On ..... 31</p> <p style="padding-left: 20px;">Inspection 2: Warning Lamp Stays On When Ignition Switch Is Turned On ..... 31</p> <p style="padding-left: 20px;">Inspection 3: Warning Lamp Blinks When Ignition Switch Is Turned On ..... 33</p> <p style="padding-left: 20px;">Inspection 4: Turn Signal Lamp Blinks When Ignition Switch Is Turned On ..... 34</p> <p style="padding-left: 20px;">Inspection 5: ID Registration Can Not Be Completed.. 34</p> <p><b>REMOVAL AND INSTALLATION</b> ..... 35</p> <p style="padding-left: 20px;">Transmitter ..... 35</p> <p style="padding-left: 40px;">REMOVAL ..... 35</p> <p style="padding-left: 40px;">INSTALLATION ..... 35</p> <p><b>SERVICE DATA</b> ..... 37</p> <p style="padding-left: 20px;">Road Wheel ..... 37</p> <p style="padding-left: 20px;">Tire ..... 37</p> <p style="padding-left: 20px;">Tightening Torque ..... 37</p>	<p>F</p> <p>G</p> <p>H</p> <p>I</p> <p>J</p> <p>K</p> <p>L</p> <p>M</p>
--	--	---

# PREPARATION

## PREPARATION

PFP:00002

### Special Service Tools

AES000JI

The actual shapes of Kent-Moore tools may differ from those of special service tools illustrated here.

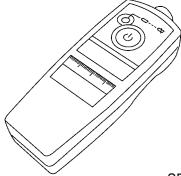
Tool number (Kent-Moore No.) Tool name	Description
(J45295) Transmitter activation tool  SEIA0462E	ID registration

### Commercial Service Tools

AES000JJ

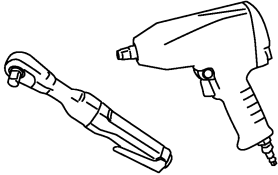
Tool name	Description
Power tool  PBIC0190E	Removing wheel nuts

# NOISE, VIBRATION AND HARSHNESS (NVH) TROUBLESHOOTING

## NOISE, VIBRATION AND HARSHNESS (NVH) TROUBLESHOOTING

PFP:00003

### NVH Troubleshooting Chart

AES000JK

Use the chart below to help you find the cause of the symptom. If necessary, repair or replace these parts.

Reference page		FAX-4, FSU-6	WT-4	—	—	—	—	—	—	—	NVH in PR section	NVH in RFD section	NVH in FAX and FSU section	NVH in RAX and RSU section	Refer to TIRES in this chart.	Refer to ROAD WHEEL in this chart.	NVH in FAX, RAX section	NVH in BR section	NVH in PS section	
Possible cause and SUSPECTED PARTS		Improper installation, looseness	Out-of-round	Imbalance	Incorrect tire pressure	Uneven tire wear	Deformation or damage	Non-uniformity	Incorrect tire size	PROPELLER SHAFT	DIFFERENTIAL	FRONT AXLE AND FRONT SUSPENSION	REAR AXLE AND REAR SUSPENSION	TIRES	ROAD WHEEL	DRIVE SHAFT	BRAKE	STEERING		
Symptom	TIRES	Noise	x	x	x	x	x	x	x	x	x	x	x	x	x	x	x	x	x	
		Shake	x	x	x	x	x	x	x	x	x	x	x	x	x	x	x	x	x	x
		Vibration				x				x	x		x	x			x			x
		Shimmy	x	x	x	x	x	x	x	x			x	x	x			x		x
		Judder	x	x	x	x	x	x		x			x	x		x		x		x
		Poor quality ride or handling	x	x	x	x	x	x		x			x	x		x				
	ROAD WHEEL	Noise	x	x	x			x			x	x	x	x	x		x	x	x	x
		Shake	x	x	x			x			x		x	x	x		x	x	x	x
		Shimmy, Judder	x	x	x			x					x	x	x			x		x
		Poor quality ride or handling	x	x	x			x					x	x	x					

x: Applicable

A  
B  
C  
D  
WT  
F  
G  
H  
I  
J  
K  
L  
M

# ROAD WHEEL

## ROAD WHEEL

PFP:40300

### Inspection ALUMINUM WHEEL

AES0000P

1. Check tires for wear and improper inflation.
2. Check wheels for deformation, cracks and other damage. If deformed, remove wheel and check wheel runout.
  - a. Remove tire from aluminum wheel and mount on a tire balance machine.
  - b. Set dial indicator as shown in the figure.

**Wheel runout (Dial indicator value):**

**Refer to [WT-37, "SERVICE DATA"](#)**

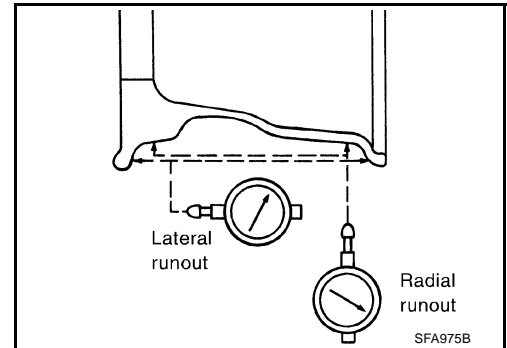

### STEEL WHEEL

1. Check tires for wear and improper inflation.
2. Check wheels for deformation, cracks and other damage. If deformed, remove wheel and check wheel runout.
  - a. Remove tire from steel wheel and mount wheel on a tire balance machine.
  - b. Set two dial indicators as shown in the figure.
  - c. Set each dial indicator to 0.
  - d. Rotate wheel and check dial indicators at several points around the circumference of the wheel.
  - e. Calculate runout at each point as shown below.

$$\text{Radial runout} = (A + B)/2$$

$$\text{Lateral runout} = (C + D)/2$$

- f. Select maximum positive runout value and the maximum negative value. Add the two values to determine total runout. In case a positive or negative value is not available, use the maximum value (negative or positive) for total runout. If the total runout value exceeds the limit, replace steel wheel.

**Wheel runout : Refer to [WT-37, "SERVICE DATA"](#)**

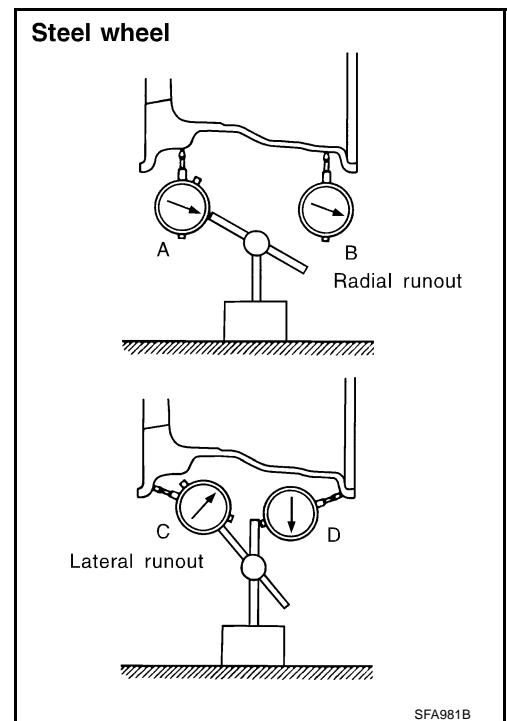

# ROAD WHEEL TIRE ASSEMBLY

## ROAD WHEEL TIRE ASSEMBLY

PPF:40300

### Balancing Wheels (Bonding Weight Type) REMOVAL

AES000JM

1. Remove inner and outer balance weights from the road wheel.

**CAUTION:**

**Be careful not to scratch the road wheel during removal.**

2. Using releasing agent, remove double-faced adhesive tape from the road wheel.

**CAUTION:**

- **Be careful not to scratch the road wheel during removal.**
- **After removing double-faced adhesive tape, wipe clean traces of releasing agent from the road wheel.**

### WHEEL BALANCE ADJUSTMENT

- If a tire balance machine has adhesion balance weight mode settings and drive-in weight mode setting, select and adjust a drive-in weight mode suitable for road wheels.

1. Set road wheel on wheel balancer using the center hole as a guide. Start the tire balance machine.
2. When inner and outer unbalance values are shown on the wheel balancer indicator, multiply outer unbalance value by  $5/3$  to determine balance weight that should be used. Select the outer balance weight with a value closest to the calculated value above and install it to the designated outer position of, or at the designated angle in relation to the road wheel.

**CAUTION:**

- **Do not install the inner balance weight before installing the outer balance weight.**
- **Before installing the balance weight, be sure to clean the mating surface of the road wheel.**

Indicated unbalance value  $\times 5/3$  = balance weight to be installed

Calculation example:

$23 \text{ g (0.81 oz)} \times 5/3 = 38.33 \text{ g (1.35 oz)} = 40 \text{ g (1.41 oz)}$  balance weight (closer to calculated balance weight value)

Note that balance weight value must be closer to the calculated balance weight value.

Example:

$37.4 = 35 \text{ g (1.23 oz)}$

$37.5 = 40 \text{ g (1.41 oz)}$

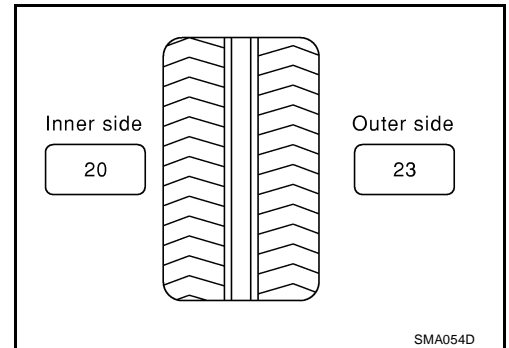

- a. Install balance weight in the position shown in the figure.
- b. When installing balance weight to road wheels, set it into the grooved area on the inner wall of the road wheel as shown in the figure so that the balance weight center is aligned with the wheel balancer indication position (angle).

**CAUTION:**

- **Always use genuine NISSAN adhesion balance weights.**
- **Balance weights are un reusable; always replace with new ones.**
- **Do not install more than three sheets of balance weight.**

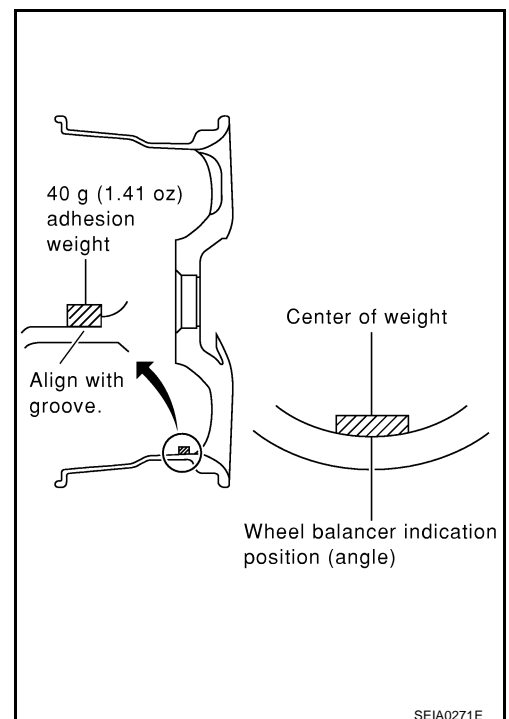

# ROAD WHEEL TIRE ASSEMBLY

- c. If calculated balance weight value exceeds 50 g (1.76 oz), install two balance weight sheets in line with each other (as shown in the figure).

**CAUTION:**

**Do not install one balance weight sheet on top of another.**

3. Start wheel balancer again.  
 4. Install drive-in balance weight on inner side of road wheel in the wheel balancer indication position (angle).

**CAUTION:**

**Do not install more than two balance weights.**

5. Start wheel balancer. Make sure that inner and outer residual unbalance values are 5.0 g (0.2 oz) each or below.
- If either residual unbalance value exceeds 5.0 g (0.2 oz), repeat installation procedures.

**Wheel balance (Maximum allowable unbalance):**

Maximum allowable unbalance	Dynamic (At rim flange)	5.0 g (0.2 oz) (one side)
	Static (At rim flange)	20 g (0.7 oz)

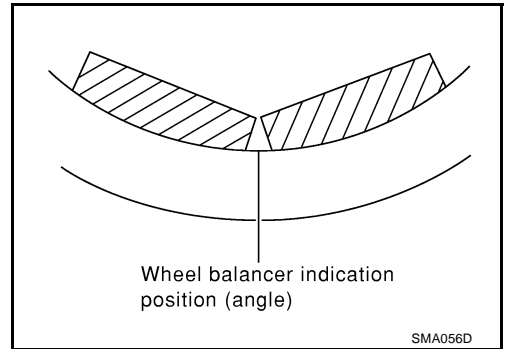

## Tire Rotation

AES0000N

- After rotating the tires, adjust the tire pressure.
- Retighten the wheel nuts when the vehicle has been driven for 1,000 km (600 miles) (also in cases of a flat tire, etc.).

**CAUTION:**

- **Do not include the T-type spare tire when rotating the tires.**
- **When installing wheels, tighten them diagonally by dividing the work two to three times in order to prevent the wheels from developing any distortion.**

**Tightening torque of wheel nut**

 : 112.5 N·m (11 kg, 83 ft·lb)

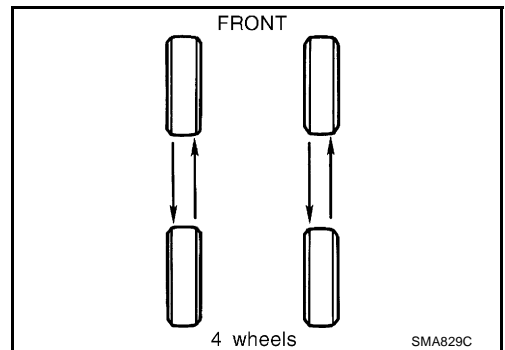

# LOW TIRE PRESSURE WARNING SYSTEM

## LOW TIRE PRESSURE WARNING SYSTEM

PFP:40300

### System Components

AES000YZ

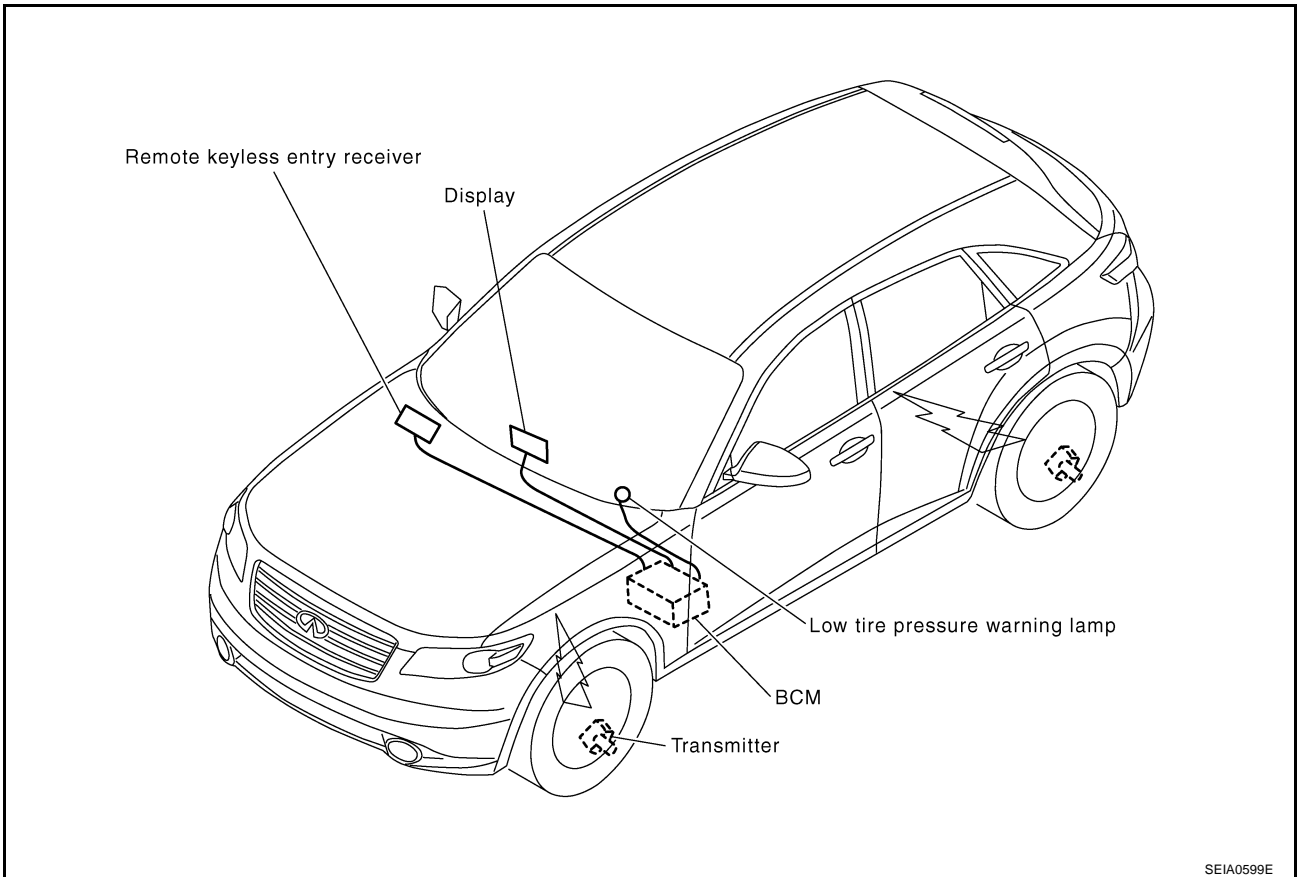

SEIA0599E

### System Description TRANSMITTER

AES000Z0

A sensor-transmitter integrated with a valve is installed on a wheel, and transmits a detected air pressure signal in the form of a radio wave.

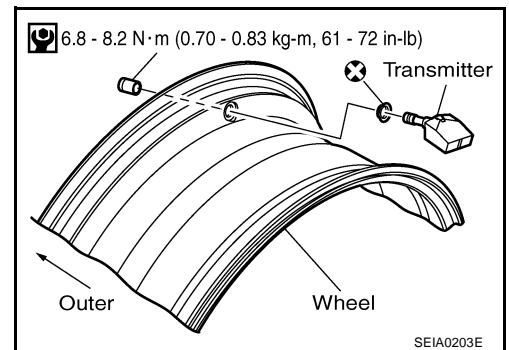

SEIA0203E

### REMOTE KEYLESS ENTRY RECEIVER

The remote keyless entry receiver receives the air pressure signal transmitted by the transmitter in each wheel.

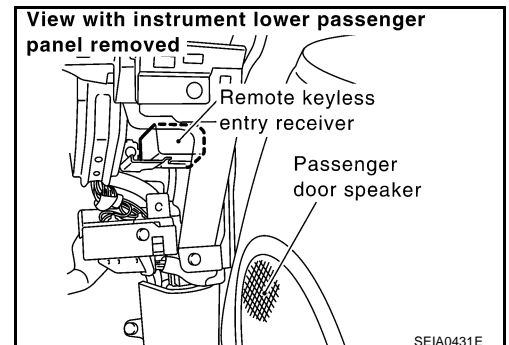

SEIA0431E

A  
B  
C  
D  
WT  
F  
G  
H  
I  
J  
K  
L  
M

# LOW TIRE PRESSURE WARNING SYSTEM

## BCM (BODY CONTROL MODULE)

The BCM reads the air pressure signal received by the remote keyless entry receiver, and controls the low tire pressure warning lamp and the buzzer operations as shown below. It also has a judgement function to detect a system malfunction.

Condition	Warning lamp	Buzzer
Less than 178 kPa (1.78 kg/cm <sup>2</sup> , 26 psi) [Flat tire]	ON	Sounds for 10 sec.
System malfunction	ON	OFF

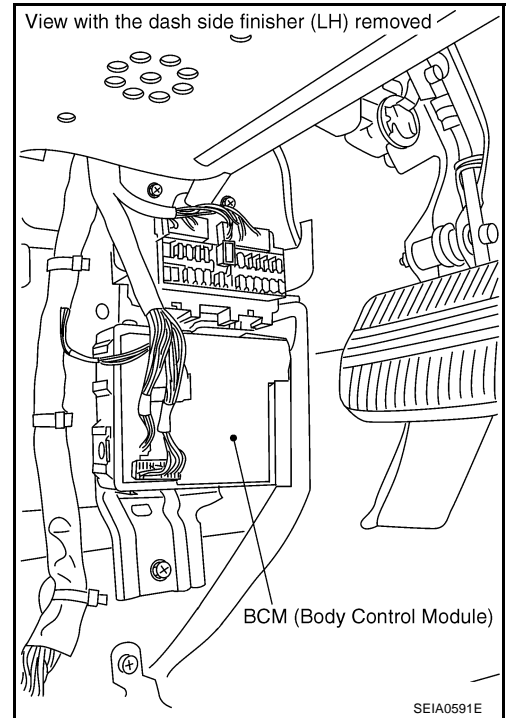

## LOW TIRE PRESSURE WARNING LAMP

The combination meter receives tire pressure status from the BCM using CAN communication. When a low tire pressure condition is sensed by the BCM, the combination meter low tire pressure warning lamp and buzzer are activated.

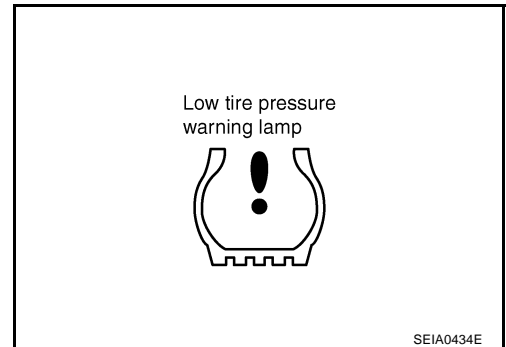

## DISPLAY UNIT

Displays the air pressure of each tire.

- After the ignition switch is turned ON, the pressure values are not displayed until the data of each wheel stabilizes.

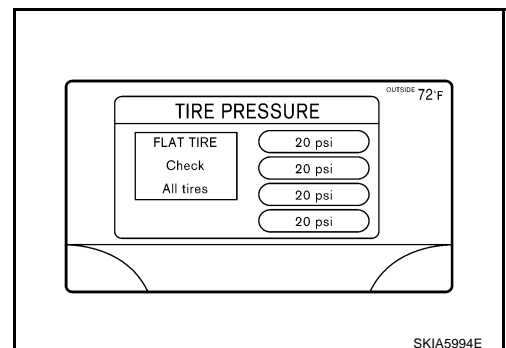



# CAN COMMUNICATION

## CAN COMMUNICATION

PFP:23710

### System Description

AES000Z1

CAN (Controller Area Network) is a serial communication line for real time application. It is an on-vehicle multiplex communication line with high data communication speed and excellent error detection ability. Many electronic control units are equipped onto a vehicle, and each control unit shares information and links with other control units during operation (not independent). In CAN communication, control units are connected with 2 communication lines (CAN H line, CAN L line) allowing a high rate of information transmission with less wiring. Each control unit transmits/receives data but selectively reads required data only.

Refer to [LAN-30, "CAN COMMUNICATION"](#).

A

B

C

D

WT

F

G

H

I

J

K

L

M

# TROUBLE DIAGNOSES

## TROUBLE DIAGNOSES

PFP:00004

### Schematic

AES00022

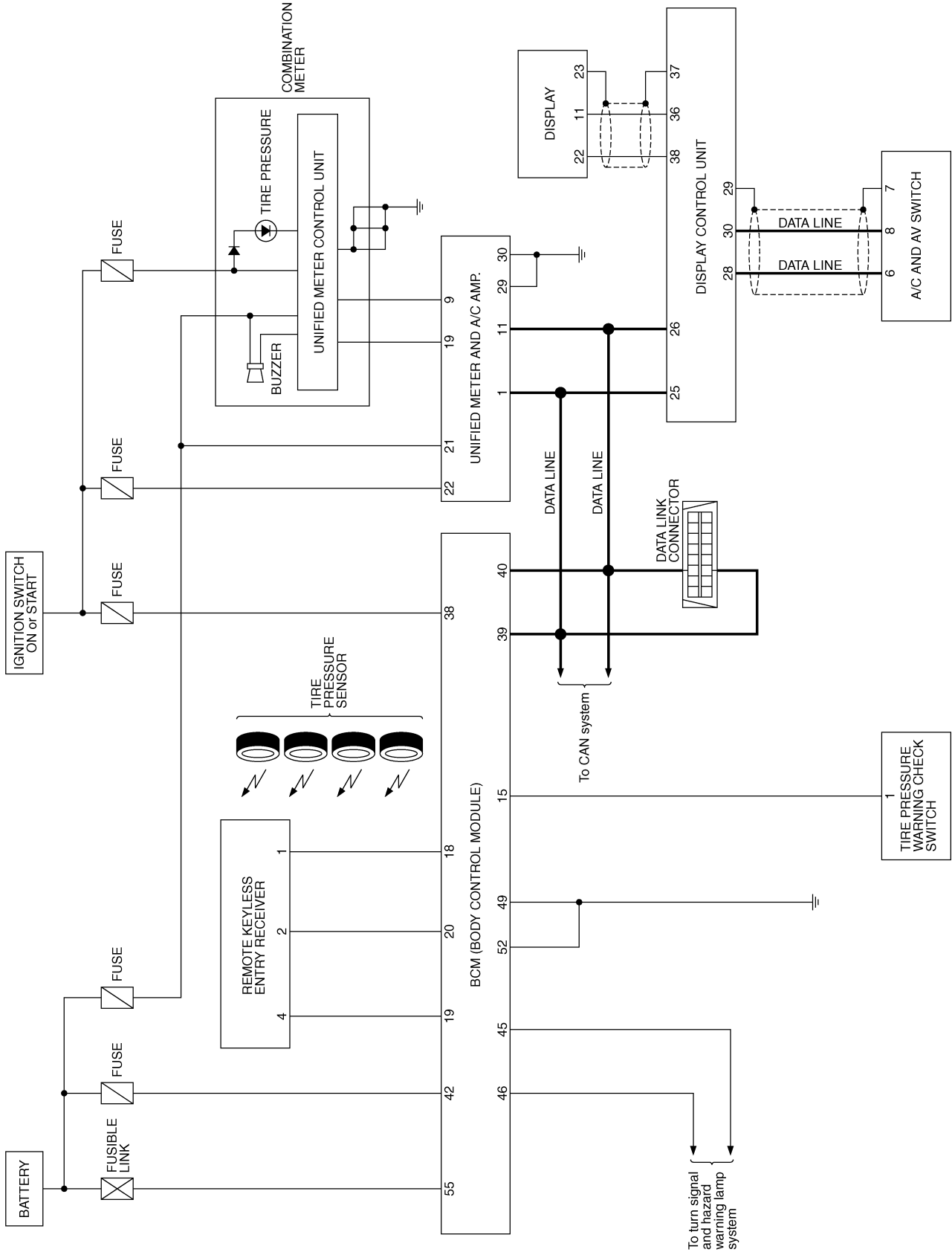

TEWM0101E

# TROUBLE DIAGNOSES

## Wiring Diagram

AES00023

### WT-T/WARN-01

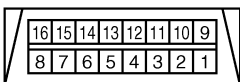
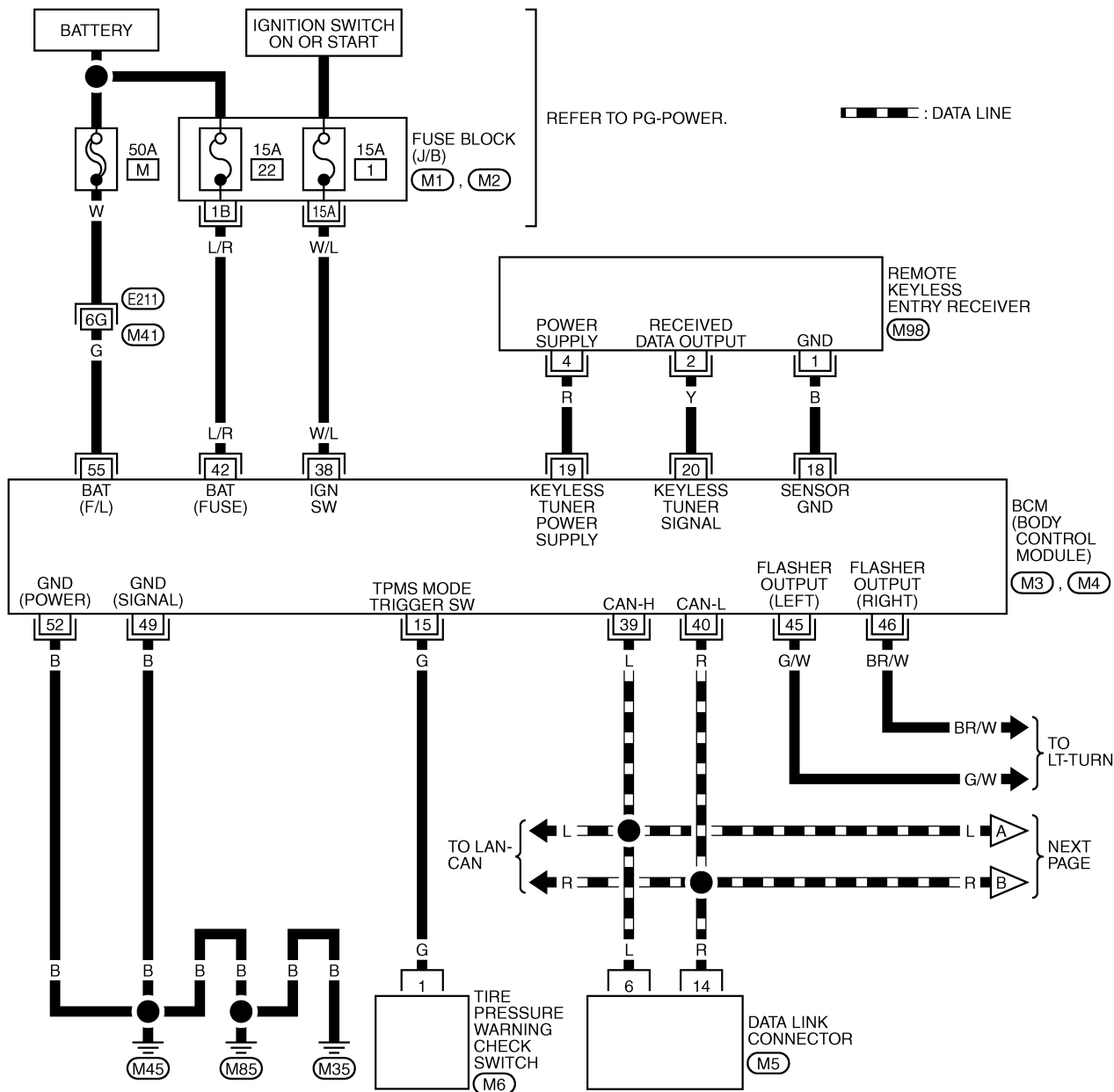

(M5)  
W

2 1  
(M6)  
W

4 3 2 1  
(M98)  
W

REFER TO THE FOLLOWING.

- (E211) -SUPER MULTIPLE JUNCTION (SMJ)
- (M1), (M2) -FUSE BLOCK-JUNCTION BOX (J/B)
- (M3), (M4) -ELECTRICAL UNITS

TEWM0102E

# TROUBLE DIAGNOSES

WT-T/WARN-02

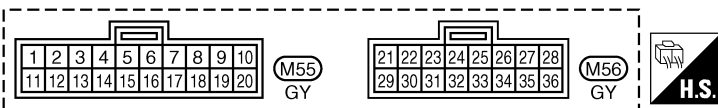
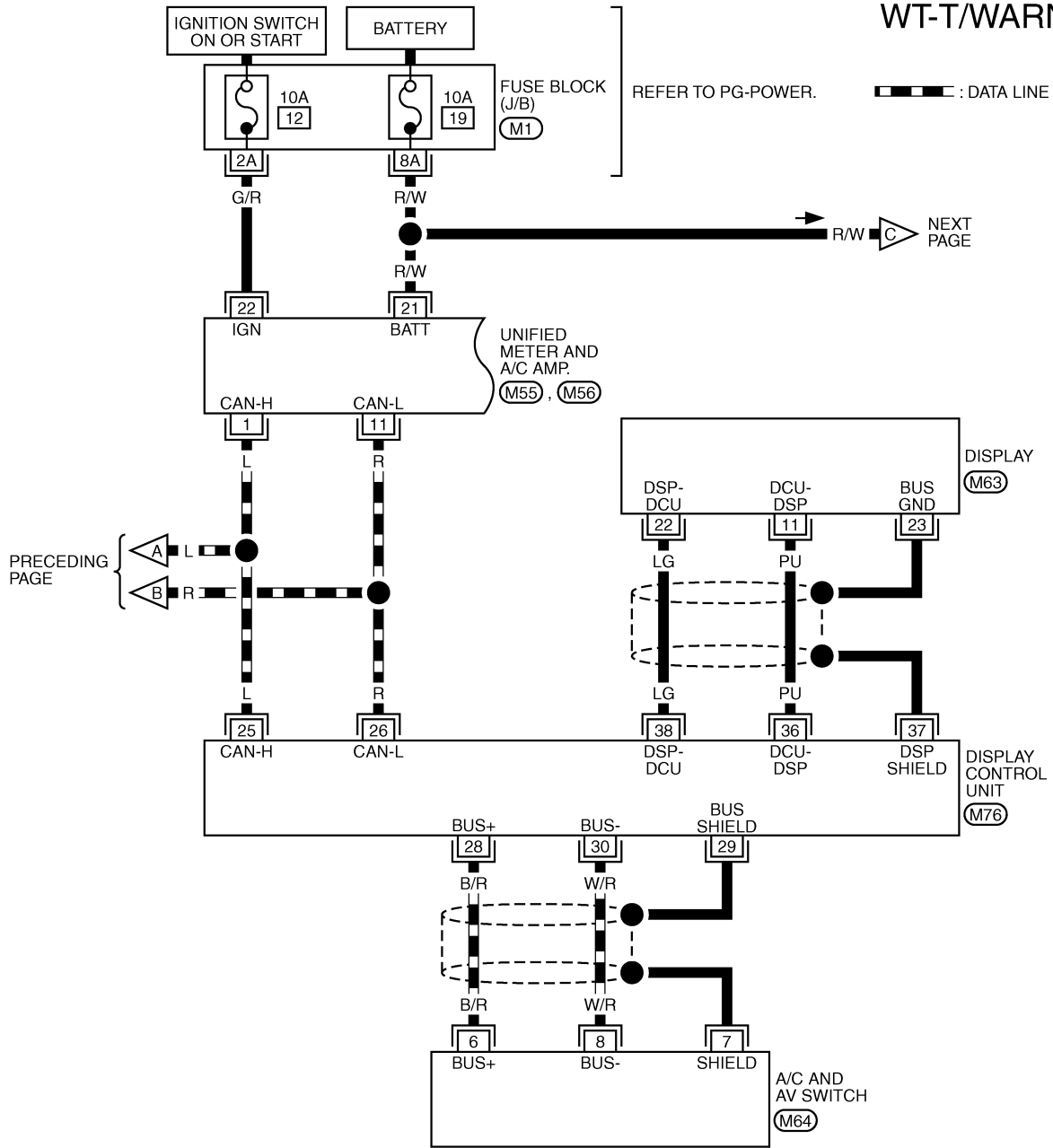

REFER TO THE FOLLOWING.  
 (M1) - FUSE BLOCK-JUNCTION BOX (J/B)

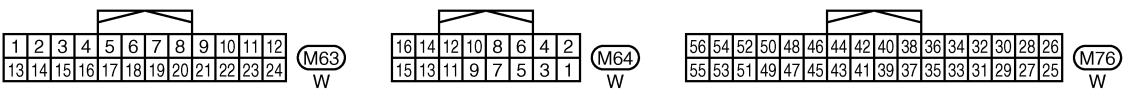

TEWM0103E

# TROUBLE DIAGNOSES

WT-T/WARN-03

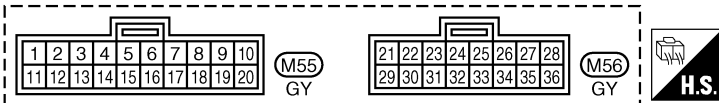
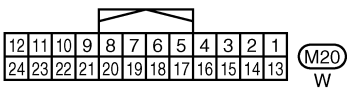
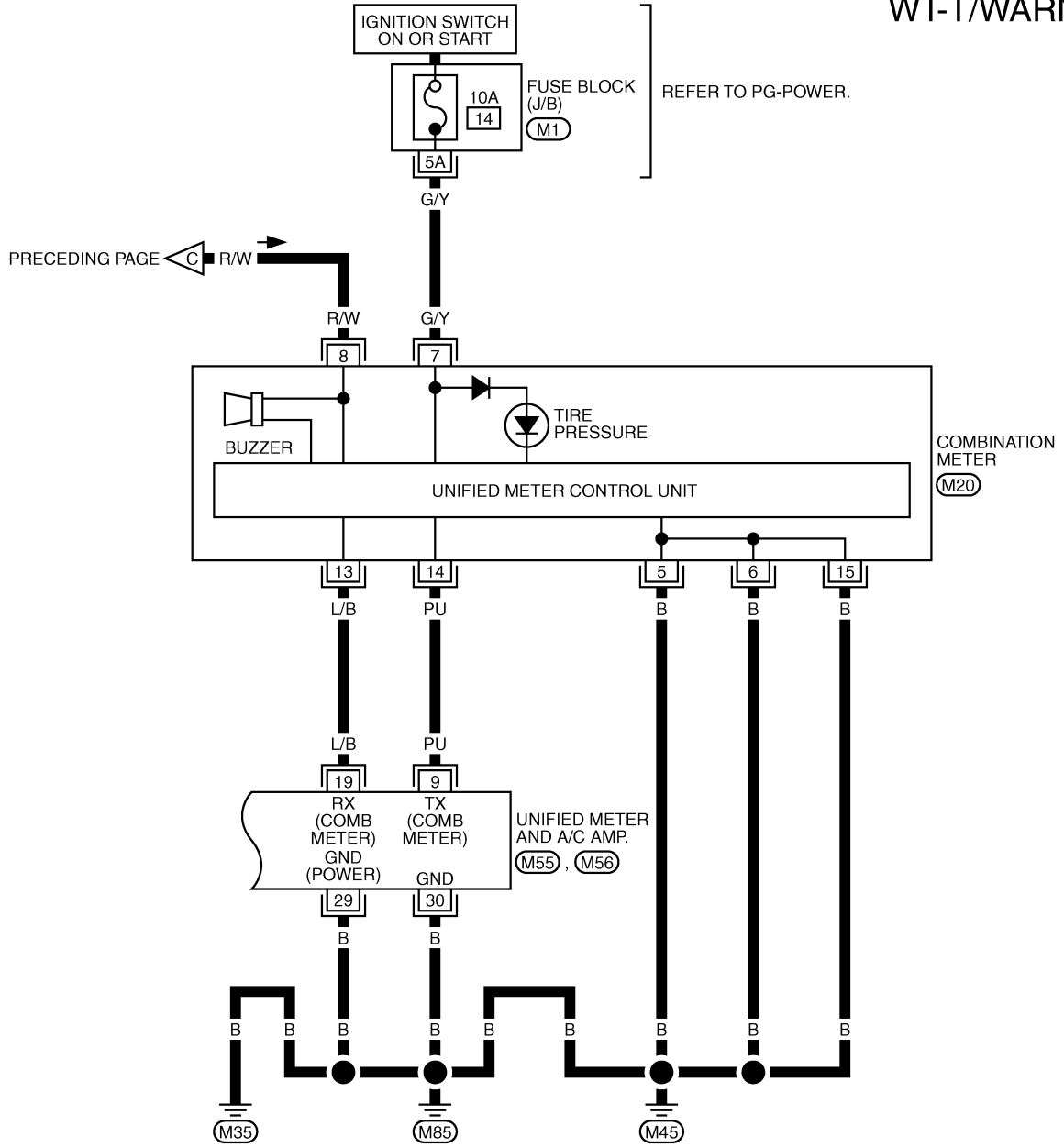

REFER TO THE FOLLOWING.

(M1) - FUSE BLOCK-JUNCTION BOX (J/B)

TEWM0104E

# TROUBLE DIAGNOSES

## Control Unit Input/Output Signal Standard

AES000Z4

### Standards using a circuit tester and oscilloscope

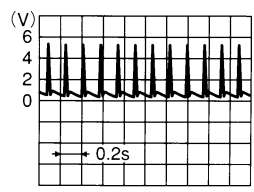
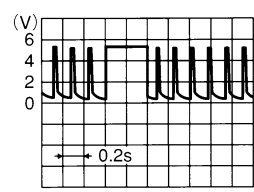
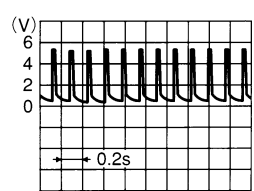
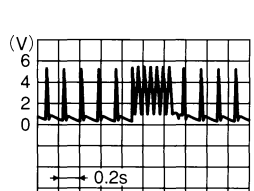
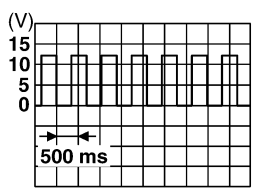
Terminal		Item	Condition	Voltage (V) Approx. value	
+	-				
15 (G)	Ground	Tire pressure warning check connector	Always	5V	
18 (B)		Remote keyless entry receiver (Ground)	—	0V	
19 (R)		Remote keyless entry receiver (Power supply)	Stand-by		OCC3879D
			Press any of the keyfob switches		OCC3882D
20 (Y)		Remote keyless entry receiver (Signal)	Stand-by		OCC3881D
			Press any of the keyfob switches		OCC3880D
38 (W/L)		Ignition switch	Ignition switch ON or START	Battery voltage (12V)	
39 (L)		Data line (CAN H)	—	—	
40 (R)		Data line (CAN L)	—	—	
42 (L/R)		Battery power supply (Fuse)	Always	Battery voltage (12V)	
45 (G/W)	Turn signal (left)	<ul style="list-style-type: none"> <li>● Ignition switch ON</li> <li>● Combination switch is turn signal (left)</li> </ul>		SKIA3009J	

# TROUBLE DIAGNOSES

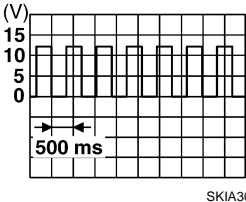
Terminal		Item	Condition	Voltage (V) Approx. value
+	-			
46 (BR/W)	Ground	Turn signal (right)	<ul style="list-style-type: none"> <li>● Ignition switch ON</li> <li>● Combination switch is turn signal (right)</li> </ul>	
49 (B)		Ground	—	0V
52 (B)				
55 (G)		Battery power supply (F/L)	Always	Battery voltage (12V)

( ): Wire color

A  
B  
C  
D  
WT  
F  
G  
H  
I  
J  
K  
L  
M

# TROUBLE DIAGNOSES

AES000Z5

## ID Registration Procedure

### ID REGISTRATION WITH ACTIVATION TOOL

This procedure must be done after replacement of a transmitter or BCM.

**CAUTION:**

If CONSULT-II is used with no connection of CONSULT-II CONVERTER, malfunction might be detected during self-diagnosis depending on control unit which performs CAN communication.

1. With the ignition switch OFF, connect CONSULT-II and CONSULT-II CONVERTER to the data link connector, then turn the ignition switch ON.
2. Select "START (NISSAN BASED VHCL)".
3. Select "BCM" on "SELECT SYSTEM" screen.

**NOTE:**

If "BCM" is not indicated, go to [GI-39, "CONSULT-II Data Link Connector \(DLC\) Circuit"](#) .

4. Select "AIR PRESSURE MONITOR" on "SELECT WORK ITEM" screen.
5. Select "WORK SUPPORT" on "SELECT DIAG MODE" screen, and select "ID REGIST".
6. With the activation tool (J-45295) pushed against the front-left transmitter position of the tire air valve, press and hold the button 5 seconds.

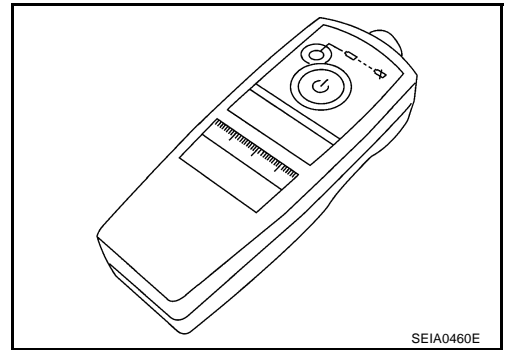

7. Register the IDs in order from FR LH, FR RH, RR RH or RR LH. When ID registration of each wheel has been completed, a buzzer sounds and turn signal lamp (LH/ RH) blinks.

Activation tire position	Buzzer	Turn signal lamp	CONSULT-II
1 Front LH	Once	2 times flashing	"YET" ↓ "DONE"
2 Front RH	2 times		
3 Rear RH	3 times		
4 Rear LH	4 times		

8. After completing all ID registrations, press "END" to complete the procedure.

**NOTE:**

Be sure to register the IDs in order from FR LH, FR RH, RR RH, to RR LH, or the self-diagnostic results display will not function properly.



# TROUBLE DIAGNOSES

## ID REGISTRATION WITHOUT ACTIVATION TOOL

This procedure must be done after replacement of a transmitter or BCM.

**CAUTION:**

If CONSULT-II is used with no connection of CONSULT-II CONVERTER, malfunction might be detected during self-diagnosis depending on control unit which performs CAN communication.

1. With the ignition switch OFF, connect CONSULT-II and CONSULT-II CONVERTER to the data link connector, then turn the ignition switch ON.
2. Select "START (NISSAN BASED VHCL)".
3. Select "BCM" on "SELECT SYSTEM" screen.

**NOTE:**

If "BCM" is not indicated, go to [GI-39, "CONSULT-II Data Link Connector \(DLC\) Circuit"](#).

4. Select "AIR PRESSURE MONITOR" on "SELECT WORK ITEM" screen.
5. Select "WORK SUPPORT" on "SELECT DIAG MODE" screen, and select "ID REGIST".
6. Adjust the tire pressure to the values shown in the table below for ID registration, and drive the vehicle at 40 km/h (25 MPH) or more for a few minutes.

Tire position	Tire pressure kPa (kg/cm <sup>2</sup> , psi)
Front – Left	240 (2.4, 34)
Front – Right	220 (2.2, 31)
Rear – Right	200 (2.0, 29)
Rear – Left	180 (1.8, 26)

7. After completing all ID registrations, press "END" to complete the procedure.

Activation tire position	CONSULT-II
Front LH	"YET" ↓ "DONE"
Front RH	
Rear RH	
Rear LH	

8. Inflate all tires to proper pressure. Refer to [WT-37, "Tire"](#).

A  
B  
C  
D  
WT  
F  
G  
H  
I  
J  
K  
L  
M

# TROUBLE DIAGNOSES

## Transmitter Wake Up Operation WITH ACTIVATION TOOL

AES000Z6

1. With the activation tool (J-45295) pushed against the front-left transmitter, press the button for 5 seconds.
  - When ignition switch ON, as the low tire pressure warning lamp blinks per the following diagram, the respective transmitter then must be woken up.

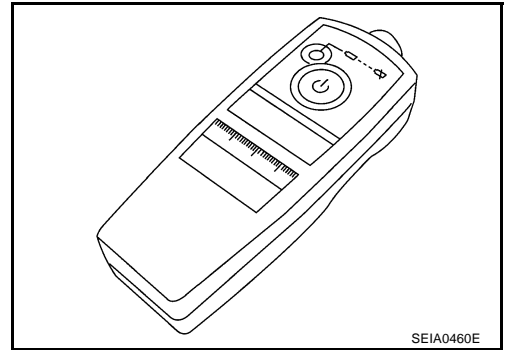

Warning lamp blinking timing		Need to activation tire position
ON OFF	a : 0.3sec b : 1.3sec	Front LH
ON OFF	a : 0.3sec b : 1.3sec	Front RH
ON OFF	a : 0.3sec b : 1.3sec	Rear RH
ON OFF	a : 0.3sec b : 1.3sec	Rear LH
ON OFF	a : 2sec b : 0.2sec	All tire

SEIA0378E

2. Register the ID of wheel that warning lamp flashes. When wake up of registered wheel has been completed, turn signal lamp flashes two times.
3. After completing wake up all transmitters, make sure low tire pressure warning lamp goes out.

# TROUBLE DIAGNOSES

AES000Z7











## Self-Diagnosis DESCRIPTION

During driving, the low tire pressure warning system receives the signal transmitted from the transmitter installed in each wheel, and gives alarms when the tire pressure becomes low. The control unit (BCM) of this system has pressure judgement and trouble diagnosis functions.



## FUNCTION

When the low tire pressure warning system detects low inflation pressure or another unusual symptom, the warning lamps in the combination meter comes on. To start the self-diagnostic results mode, ground terminal of the tire pressure warning check connector. The malfunction location is indicated by the warning lamp flashing and the buzzer sounds.

## LOW TIRE PRESSURE WARNING LAMP DIAGNOSTIC CHART

Diagnosis Item	Symptom (Ignition switch ON)	Low tire pressure warning lamp	Cause	Action
Low tire pressure warning lamp	Warning lamp comes on immediately and turns off after 1 second	  ON 1 sec > stays OFF <small>SEIA0592E</small>	All wheel transmitters are "activated" (working).	None (system OK)
	Warning lamp blinks on for 2 seconds, then turns off for 0.2 seconds-repeats	 Blinks:  ON 2 sec > OFF 0.2 sec <small>SEIA0593E</small>	All wheel transmitters are not activated.	Activate all wheel transmitters. Refer to <a href="#">WT-18, "Transmitter Wake Up Operation"</a> .
	Warning lamp blinks 1 time	 Blinks 1 time ON 0.3 sec > OFF 1.3 sec <small>SEIA0594E</small>	Front LH wheel transmitter is not activated.	Activate front LH wheel transmitter. Refer to <a href="#">WT-18, "Transmitter Wake Up Operation"</a> .
	Warning lamp blinks 2 times	  Blinks 2 times ON 0.3 sec > OFF 0.3 sec <small>SEIA0595E</small>	Front RH wheel transmitter is not activated.	Activate front RH wheel transmitter. Refer to <a href="#">WT-18, "Transmitter Wake Up Operation"</a> .
	Warning lamp blinks 3 times	   Blinks 3 times ON 0.3 sec > OFF 0.3 sec <small>SEIA0596E</small>	Rear RH wheel transmitter is not activated.	Activate rear RH wheel transmitter. Refer to <a href="#">WT-18, "Transmitter Wake Up Operation"</a> .

# TROUBLE DIAGNOSES

Diagnosis Item	Symptom (Ignition switch ON)	Low tire pressure warning lamp	Cause	Action
Low tire pressure warning lamp	Warning lamp blinks 4 times	 Blinks 4 times ON 0.3 sec > OFF 0.3 sec <small>SEIA0597E</small>	Rear LH wheel transmitter is not activated.	Activate rear LH wheel transmitter. Refer to <a href="#">WT-18, "Transmitter Wake Up Operation"</a> .
	Warning lamp comes on and does not turn off	 Comes ON and stays ON <small>SEIA0598E</small>	The fuse for combination meter from battery is pulled out.	Check the fuse for combination meter from battery. Install or replace (if needed).
			BCM connector pulled out.	Check BCM connector. Re-connect if needed.
			Low tire pressure or low tire pressure warning system malfunction.	<ul style="list-style-type: none"> <li>● Perform CONSULT-II Self Diagnosis. Refer to <a href="#">WT-19, "Self-Diagnosis"</a>.</li> <li>– Perform ID Registration if needed. Refer to <a href="#">WT-16, "ID Registration Procedure"</a>.</li> </ul>
Turn signal lamp	Turn signal lamp does not flash 2 times or horn does not sound after transmitter activation.		<ol style="list-style-type: none"> <li>1. Tool J-45295 (special service tool) battery low.</li> <li>2. Ignition OFF during activation.</li> <li>3. Tool J-45295 (special service tool) not positioned correctly.</li> <li>4. Transmitters already activated.</li> </ol>	<ol style="list-style-type: none"> <li>1. Install new battery.</li> <li>2. Make sure ignition is ON during activation.</li> <li>3. Position tool correctly during activation.</li> <li>4. None</li> </ol>

**NOTE:**

If more than one wheel transmitter is NOT activated, the warning lamp blinking patterns for those wheels will combine. (Example: one blink/OFF/three blinks = Rear LH and Rear RH transmitters are not activated.)

**CONSULT-II**

**CONSULT-II Main Function**

In a diagnosis function (main function), there are "WORK SUPPORT", "SELF-DIAGNOSTIC RESULTS", "DATA MONITOR", "ACTIVE TEST".

Diagnostic test mode	Function	Reference
WORK SUPPORT	This mode enables a technician to adjust some devices faster and more accurately by following the indications on CONSULT-II.	<a href="#">WT-21, "WORK SUPPORT MODE"</a> .
SELF-DIAGNOSTIC RESULTS	Self-diagnostic results can be read and erased quickly.	<a href="#">WT-21, "SELF-DIAGNOSTIC RESULTS MODE"</a> .
DATA MONITOR	Input/Output data in the control unit can be read.	<a href="#">WT-22, "DATA MONITOR MODE"</a> .
ACTIVE TEST	Diagnostic Test Mode in with CONSULT-II drives some actuators apart from the control unit (BCM) and also shifts some parameters in a specified range.	<a href="#">WT-22, "ACTIVE TEST MODE"</a> .

# TROUBLE DIAGNOSES

## WORK SUPPORT MODE

### Operation Procedure

1. Touch necessary test item.
2. The "Work support" screen will be displayed, so perform the following test.

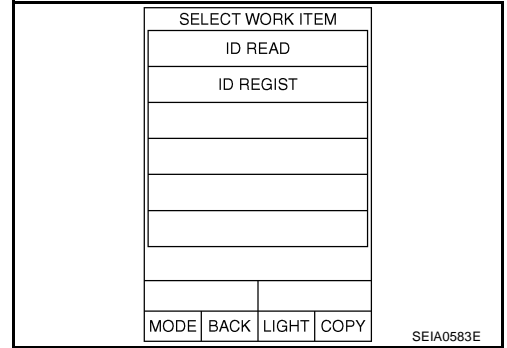

### Test Item

- ID Read
- ID Regist

### ID Read

The registered ID number is displayed.

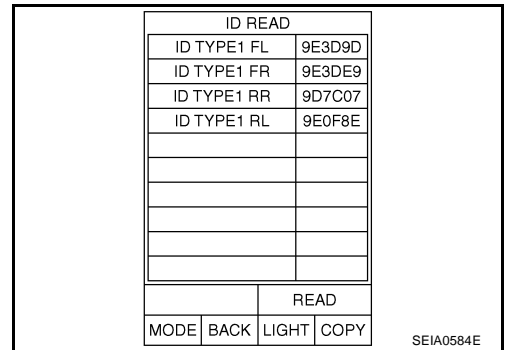

### ID Regist

Refer to [WT-16, "ID Registration Procedure"](#) .

## SELF-DIAGNOSTIC RESULTS MODE

Diagnostic item	Diagnostic item is detected when ...
FLAT - TIRE - FL FLAT - TIRE - FR FLAT - TIRE - RR FLAT - TIRE - RL	Front-left tire pressure drops to 178 kPa (1.78 kg/cm <sup>2</sup> , 26 psi) or less. Front-right tire pressure drops to 178 kPa (1.78 kg/cm <sup>2</sup> , 26 psi) or less. Rear-right tire pressure drops to 178 kPa (1.78 kg/cm <sup>2</sup> , 26 psi) or less. Rear-left tire pressure drops to 178 kPa (1.78 kg/cm <sup>2</sup> , 26 psi) or less.
[NO-DATA] - FL [NO-DATA] - FR [NO-DATA] - RR [NO-DATA] - RL	Data from front-left transmitter can not be received. Data from front-right transmitter can not be received. Data from rear-right transmitter can not be received. Data from rear-left transmitter can not be received.
[CHECKSUM- ERR] - FL [CHECKSUM- ERR] - FR [CHECKSUM- ERR] - RR [CHECKSUM- ERR] - RL	Checksum data from front-left transmitter is malfunctioning. Checksum data from front-right transmitter is malfunctioning. Checksum data from rear-right transmitter is malfunctioning. Checksum data from rear-left transmitter is malfunctioning.
[PRESS DATA- ERR] - FL [PRESS DATA- ERR] - FR [PRESS DATA- ERR] - RR [PRESS DATA- ERR] - RL	Air pressure data from front-left transmitter is malfunctioning. Air pressure data from front-right transmitter is malfunctioning. Air pressure data from rear-right transmitter is malfunctioning. Air pressure data from rear-left transmitter is malfunctioning.
[CODE- ERR] - FL [CODE- ERR] - FR [CODE- ERR] - RR [CODE- ERR] - RL	Function code data from front-left transmitter is malfunctioning. Function code data from front-right transmitter is malfunctioning. Function code data from rear-right transmitter is malfunctioning. Function code data from rear-left transmitter is malfunctioning.

# TROUBLE DIAGNOSES

Diagnostic item	Diagnostic item is detected when ...
[BATT - VOLT - LOW] - FL [BATT - VOLT - LOW] - FR [BATT - VOLT - LOW] - RR [BATT - VOLT - LOW] - RL	Battery voltage of front-left transmitter drops. Battery voltage of front-right transmitter drops. Battery voltage of rear-right transmitter drops. Battery voltage of rear-left transmitter drops.
VHCL_SPEED_SIG_ERR	Vehicle speed signal is error.

**NOTE:**

Before performing the self-diagnosis, be sure to register the ID, or else the actual malfunction location may be different from that displayed on CONSULT-II.

## DATA MONITOR MODE

MONITOR	CONDITION	SPECIFICATION
VEHICLE SPEED	Drive vehicle.	Vehicle speed (km/h or MPH)
AIR PRESS FL AIR PRESS FR AIR PRESS RR AIR PRESS RL	<ul style="list-style-type: none"> <li>● Drive vehicle for a few minutes.</li> <li style="text-align: center;">or</li> <li>● Ignition switch ON and activation tool is transmitting activation signals.</li> </ul>	Tire pressure (kPa or Psi)
ID REGST FL 1 ID REGST FR 1 ID REGST RR 1 ID REGST RL 1	Ignition switch ON	Registration ID: DONE No registration ID: YET
WARNING LAMP		Low tire pressure warning lamp on: ON Low tire pressure warning lamp off: OFF
BUZZER		Buzzer in combination meter on: ON Buzzer in combination meter off: OFF

**NOTE:**

Before performing the self-diagnosis, be sure to register the ID, or else the actual malfunction location may be different from that displayed on CONSULT-II.

## ACTIVE TEST MODE

**NOTE:**

Before performing the self-diagnosis, be sure to register the ID, or else the actual malfunction location may be different from that displayed on CONSULT-II.

### Operation Procedure

1. Touch necessary test item.
2. The "Active Test" screen will be displayed, so perform the following test.

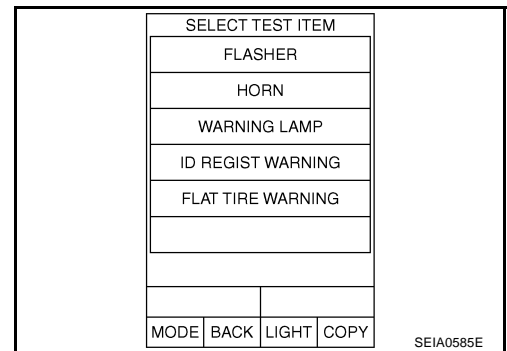

### Test Item

- Flasher
- Horn
- Warning lamp
- ID regist warning
- Flat tire warning

# TROUBLE DIAGNOSES

## Flasher

Touch "LH" and "RH" on the display, and then check to make sure that each turn signal lamp turns on.

ACTIVE TEST			
FLASHER		LH	
RH			OFF
MODE	BACK	LIGHT	COPY

SEIA0586E

A  
B  
C  
D

## Horn

Touch "LH" and "RH" on the display, and then check to make sure that the horn sounds.

ACTIVE TEST			
HORN		OFF	
ON			
MODE	BACK	LIGHT	COPY

SEIA0587E

WT

F  
G  
H

## Warning Lamp

Touch "LH" and "RH" on the display, and then check to make sure that the warning lamp turns on.

ACTIVE TEST			
WARNING LAMP		ON	
		OFF	
MODE	BACK	LIGHT	COPY

SEIA0588E

I  
J  
K

## ID Regist Warning

Touch "LH" and "RH" on the display, and then check to make sure that the buzzer sounds or the warning lamp turns on.

ACTIVE TEST			
ID REGIST WARNING		OFF	
ON			
MODE	BACK	LIGHT	COPY

SEIA0589E

M

# TROUBLE DIAGNOSES

## Flat Tire Warning

Touch "LH" and "RH" on the display, and then check to make sure that the buzzer sounds or the warning lamp turns on.

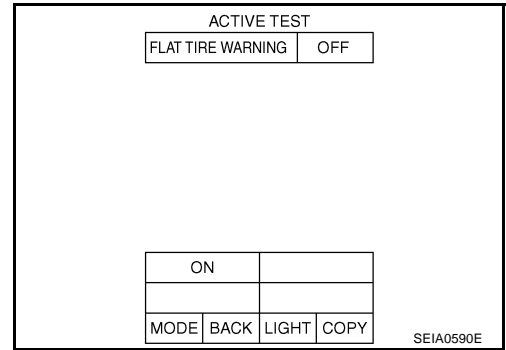



# TROUBLE DIAGNOSES

## How to Perform Trouble Diagnosis for Quick and Accurate Repair INTRODUCTION

AES00028

- Before troubleshooting, verify customer complaints.
- If a vehicle malfunction is difficult to reproduce, harnesses, harness connectors or terminals may be malfunctioning. Hold and shake these parts to make sure they are securely connected.
- When using a circuit tester to measure voltage or resistance of each circuit, be careful not to damage or deform connector terminals.

### WORK FLOW

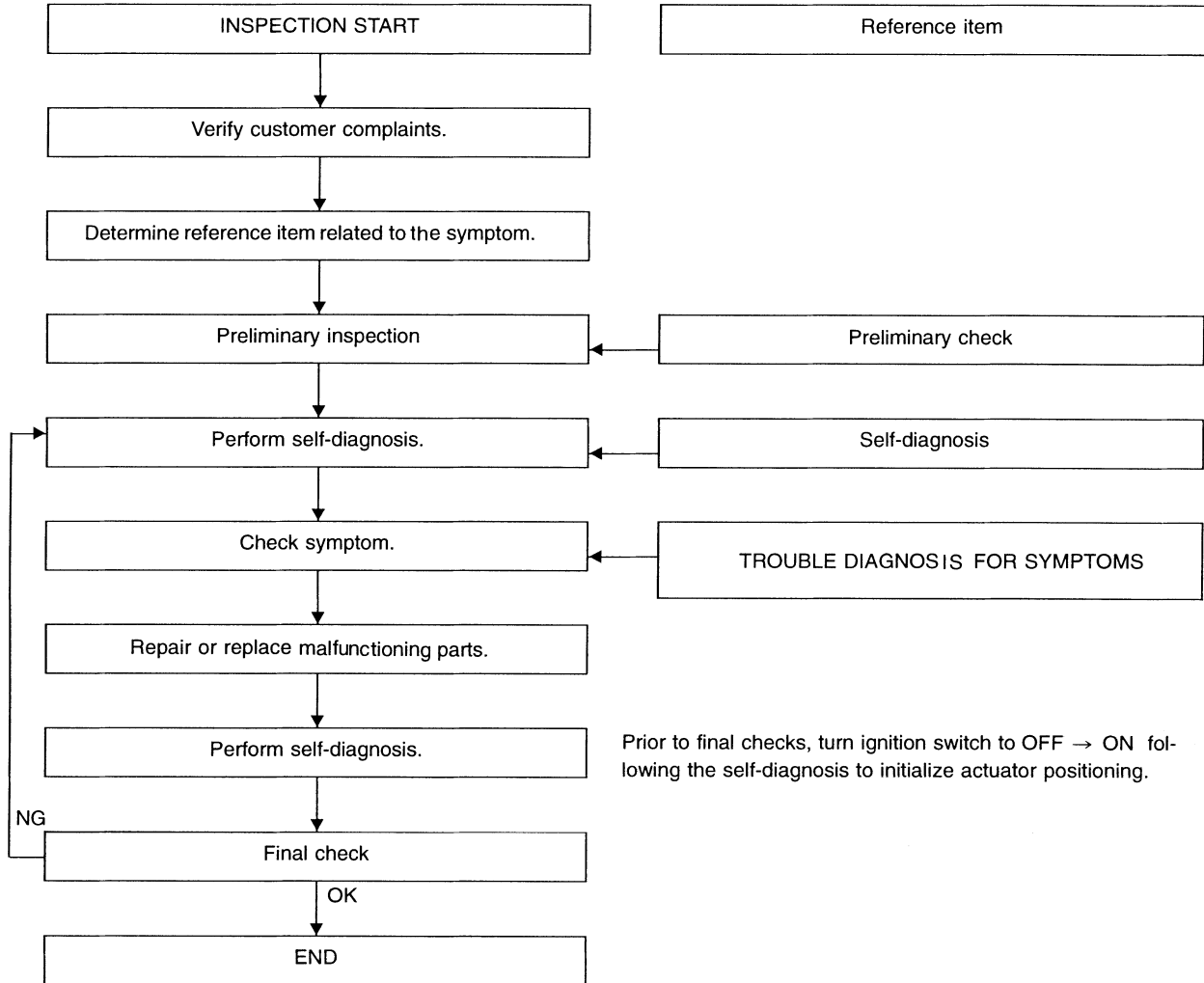

Preliminary check: [WT-26](#)

Self-diagnosis: [WT-19](#)

Trouble diagnosis for symptoms: [WT-31](#)

SEIA0100E

# TROUBLE DIAGNOSES

AES000Z9

---

## Preliminary Check

### BASIC INSPECTION

#### 1. CHECK ALL TIRE PRESSURES

---

- Check all tire pressures. Refer to [WT-37, "Tire"](#) .

##### OK or NG

- OK >> GO TO 2.  
NG >> Adjust tire pressure to specified value.

#### 2. CHECK LOW TIRE PRESSURE WARNING LAMP ACTIVATION

---

1. Check low tire pressure warning lamp activation.
2. Does low tire pressure warning lamp activate for 1 second when ignition switch is turned "ON"?

##### Does warning lamp activate?

- YES >> GO TO 3.  
NO >> Check fuse and combination meter.

#### 3. CHECK CONNECTOR

---

1. Disconnect BCM harness connectors M3 and M4.
2. Check terminals for damage or loose connection.

##### OK or NG

- OK >> GO TO 4.  
NG >> Repair or replace damaged parts.

#### 4. CHECK TRANSMITTER TOOL

---

- Check activation tool battery.

##### OK or NG

- OK >> Perform self-diagnosis.  
NG >> Replace activation tool battery.

# TROUBLE DIAGNOSES

## Malfunction Code/Symptom Chart

AES000ZA

Code/Symptom	Malfunction part	Reference page
15 16 17 18	Front-left tire pressure drops to 178 kPa (1.78 kg/cm <sup>2</sup> , 26 psi) or less. Front-right tire pressure drops to 178 kPa (1.78 kg/cm <sup>2</sup> , 26 psi) or less. Rear-right tire pressure drops to 178 kPa (1.78 kg/cm <sup>2</sup> , 26 psi) or less. Rear-left tire pressure drops to 178 kPa (1.78 kg/cm <sup>2</sup> , 26 psi) or less.	—
21 22 23 24	Transmitter no data (front - left) Transmitter no data (front - right) Transmitter no data (rear - right) Transmitter no data (rear - left)	<a href="#">WT-28</a>
31 32 33 34	Transmitter checksum error (front - left) Transmitter checksum error (front - right) Transmitter checksum error (rear - right) Transmitter checksum error (rear - left)	<a href="#">WT-28</a>
35 36 37 38	Transmitter pressure data error (front - left) Transmitter pressure data error (front - right) Transmitter pressure data error (rear - right) Transmitter pressure data error (rear - left)	<a href="#">WT-29</a>
41 42 43 44	Transmitter function code error (front - left) Transmitter function code error (front - right) Transmitter function code error (rear - right) Transmitter function code error (rear - left)	<a href="#">WT-28</a>
45 46 47 48	Transmitter battery voltage low (front - left) Transmitter battery voltage low (front - right) Transmitter battery voltage low (rear - right) Transmitter battery voltage low (rear - left)	<a href="#">WT-28</a>
52	Vehicle speed signal	<a href="#">WT-30</a>
Warning lamp does not come on when ignition switch is turned on.	Fuse or combination meter BCM connector or circuit BCM	<a href="#">WT-31</a>
Warning lamp stays on when ignition switch is turned on.	Combination meter BCM connector or circuit BCM	<a href="#">WT-31</a>
Warning lamp blinks when ignition switch is turned on.	BCM connector or circuit BCM Transmitter's mode off ID registration not yet	<a href="#">WT-33</a>
Turn signal lamp blinks when ignition switch is turned on.	BCM connector or circuit BCM	<a href="#">WT-34</a>
ID registration can not be operated.	Transmitter Remote keyless entry receiver connector or circuit Remote keyless entry receiver BCM connector or circuit BCM	<a href="#">WT-34</a>

A  
B  
C  
D  
E  
F  
G  
H  
I  
J  
K  
L  
M

WT

# TROUBLE DIAGNOSIS FOR SELF-DIAGNOSTIC ITEMS

---

## TROUBLE DIAGNOSIS FOR SELF-DIAGNOSTIC ITEMS

PFP:00000

### Inspection 1: Transmitter or Control Unit (BCM)

AES0002B

#### MALFUNCTION CODE NO. 21, 22, 23 OR 24

#### 1. CHECK CONTROL UNIT

---

- Drive for several minutes. Check all tire pressures with CONSULT-II "DATA MONITOR ITEM".

Are all tire pressures displayed 0 kPa?

- YES >> GO TO 2.  
NO >> GO TO 3.

#### 2. CHECK REMOTE KEYLESS ENTRY RECEIVER CONNECTOR

---

1. Disconnect remote keyless entry receiver harness connector M98.
2. Check terminals for damage or loose connection.
3. Reconnect harness connector.

OK or NG

- OK >> Replace BCM refer to [BCS-16, "Removal and Installation of BCM"](#), then GO TO 3.  
NG >> Repair or replace remote keyless entry receiver harness connector.

#### 3. ID REGISTRATION

---

- Perform ID registration of all transmitters.

Is there any tire that ID can not be registered to?

- YES >> Replace transmitter of the tire, then GO TO 5.  
NO >> GO TO 4.

#### 4. VEHICLE DRIVING

---

- Drive at a speed of 40 km/h (25 MPH) or more for several minutes without stopping.  
Check all tire pressures with CONSULT-II "DATA MONITOR ITEM" within 15 minutes after vehicle speed becomes 17 km/h (11 MPH).

Does "DATA MONITOR ITEM" display tire pressure as normal without any warning lamp?

- YES >> INSPECTION END  
NO >> GO TO 5.

#### 5. ID REGISTRATION AND VEHICLE DRIVING

---

1. Perform ID registration of all transmitters.
2. Drive at a speed of 40 km/h (25 MPH) or more for 3 minutes, and then drive the vehicle at any speed for 10 minutes. Then check all tire pressures with CONSULT-II "DATA MONITOR ITEM" within 5 minutes.

Does "DATA MONITOR ITEM" display tire pressure as normal without any warning lamp?

- YES >> INSPECTION END  
NO >> GO TO the inspection applicable to DTC.

### Inspection 2: Transmitter - 1

AES0002C

#### MALFUNCTION CODE NO. 31, 32, 33, 34, 41, 42, 43, 44, 45, 46, 47 OR 48

#### 1. ID REGISTRATION (CORRECTION OF TRANSMITTER LOCATION)

---

1. Perform ID registration of all transmitters.
2. Drive at a speed of 40 km/h (25 MPH) or more for 3 minutes, and then drive the vehicle at any speed for 10 minutes.

>> GO TO 2.

# TROUBLE DIAGNOSIS FOR SELF-DIAGNOSTIC ITEMS

---

## 2. REPLACE TRANSMITTER

---

1. Check low tire pressure warning condition again, replace malfunctioning transmitter.
2. Perform ID registration of all transmitters.

Can ID registration of all transmitters be completed?

YES >> GO TO 3.

NO >> GO TO the inspection 1. Refer to [WT-28, "Inspection 1: Transmitter or Control Unit \(BCM\)"](#) .

## 3. VEHICLE DRIVING

---

- Drive at a speed of 40 km/h (25 MPH) or more for 3 minutes, and then drive the vehicle at any speed for 10 minutes. Then check all tire pressures with CONSULT-II "DATA MONITOR ITEM" within 5 minutes.

Does "DATA MONITOR ITEM" displayed tire pressure as normal without any warning lamp?

YES >> INSPECTION END.

NO >> Replace malfunctioning transmitter, and perform "Step 3" again.

### Inspection 3: Transmitter - 2 MALFUNCTION CODE NO. 35, 36, 37 OR 38

AES000ZD

## 1. CHECK ALL TIRE PRESSURES

---

- Check all tire pressures. Refer to [WT-37, "Tire"](#) .

Are there any tires whose pressure is "64 psi" or more?

YES >> Adjust tire pressure to specified value.

NO >> GO TO 2.

## 2. VEHICLE DRIVING

---

1. Perform ID registration of all transmitters.
2. Drive at a speed of 40 km/h (25 MPH) or more for several minutes without stopping. Check all tire pressures with CONSULT-II "DATA MONITOR ITEM" within 15 minutes after vehicle speed become 17 km/h (11 MPH).

>> Replace transmitter with new one if "DATA MONITOR ITEM" displayed 64 psi or more. Then GO TO 3.

## 3. ID REGISTRATION AND VEHICLE DRIVING

---

1. Perform ID registration of all transmitters.
2. Drive at a speed of 40 km/h (25 MPH) or more for 3 minutes, and then drive the vehicle at any speed for 10 minutes. Then check all tire pressures with CONSULT-II "DATA MONITOR ITEM" within 5 minutes.

Does "DATA MONITOR ITEM" display tire pressure as normal without any warning lamp?

YES >> INSPECTION END

NO >> GO TO the inspection applicable to DTC.

# TROUBLE DIAGNOSIS FOR SELF-DIAGNOSTIC ITEMS

## Inspection 4: Vehicle Speed Signal MALFUNCTION CODE NO. 52

AES000ZE

### 1. CHECK SELF-DIAGNOSIS RESULTS

1. With the ignition switch OFF, connect CONSULT-II and CONSULT-II CONVERTER to the data link connector, then turn the ignition switch ON.
2. Select "START (NISSAN BASED VHCL)".
3. Select "BCM" on "SELECT SYSTEM" screen.

**NOTE:**

If "BCM" is not indicated, go to [GI-39, "CONSULT-II Data Link Connector \(DLC\) Circuit"](#) .

4. Select "BCM C/U" on "SELECT SYSTEM" screen.
5. Select "SELF-DIAG RESULTS" on "SELECT DIAG MODE" screen.
6. Check display contents in self-diagnostic results.

Is "CAN COMM CIRCUIT" displayed in the self-diagnosis display items?

- YES >> Malfunction in CAN communication system. GO TO [LAN-5, "Precautions When Using CONSULT-II"](#) .
- NO >> No malfunction. Check combination meter refer to [DI-5, "System Description"](#) .

# TROUBLE DIAGNOSIS FOR SYMPTOMS

## TROUBLE DIAGNOSIS FOR SYMPTOMS

PFP:00007

### Inspection 1: Warning Lamp Does Not Come On When Ignition Switch Is Turned On

AES000ZF

#### DIAGNOSTIC PROCEDURE

#### 1. CHECK SELF-DIAGNOSIS RESULTS

1. With the ignition switch OFF, connect CONSULT-II and CONSULT-II CONVERTER to the data link connector, then turn the ignition switch ON.
2. Select "START (NISSAN BASED VHCL)".
3. Select "BCM" on "SELECT SYSTEM" screen.

**NOTE:**

If the "BCM" is not indicated, go to [GI-39, "CONSULT-II Data Link Connector \(DLC\) Circuit"](#) .

4. Select "BCM C/U" on "SELECT WORK ITEM" screen, and select "SELF-DIAG RESULTS".
5. Select "SELF-DIAG RESULTS" on "SELECT DIAG MODE" screen.
6. Check display contents in self-diagnostic results.

Is "CAN COMM CIRCUIT" displayed in the self-diagnosis display items?

YES >> Malfunction in CAN communication system. GO TO [LAN-5, "Precautions When Using CONSULT-II"](#) .

NO >> No malfunction. GO TO 2.

#### 2. CHECK COMBINATION METER

- Check combination meter function.

OK or NG

OK >> GO TO 3.

NG >> Check combination meter. Refer to [DI-5, "System Description"](#) .

#### 3. CHECK LOW TIRE PRESSURE WARNING LAMP

- Disconnect BCM harness connectors M3 and M4.

Does the warning lamp activate?

YES >> Replace BCM. Refer to [BCS-16, "Removal and Installation of BCM"](#) .

NO >> Check combination meter and repair or replace.

### Inspection 2: Warning Lamp Stays On When Ignition Switch Is Turned On

AES000ZG

#### DIAGNOSTIC PROCEDURE

#### 1. CHECK CONNECTOR

1. Disconnect BCM harness connectors M3 and M4.
2. Check terminals for damage or loose connections.

OK or NG

OK >> GO TO 2.

NG >> Repair or replace damaged parts.

# TROUBLE DIAGNOSIS FOR SYMPTOMS

## 2. CHECK POWER SUPPLY CIRCUIT (BATTERY)

Make sure voltage between BCM harness connector M4 terminals 42 (GY), 55 (R) and ground.

Terminal			Voltage
(+)		(-)	
Connector	Terminal (Wire color)	Ground	12V
M4	42 (L/R), 55 (G)		

OK or NG

- OK >> GO TO 3.
- NG >> Check BCM power supply circuit for open or short.

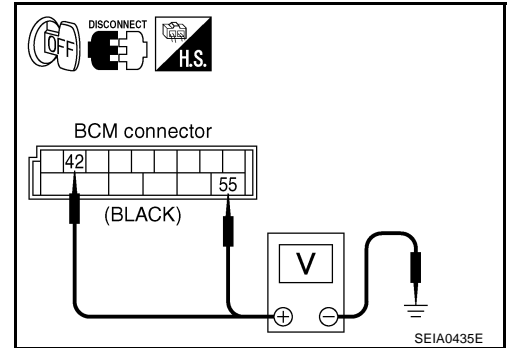

## 3. CHECK POWER SUPPLY CIRCUIT (IGN)

1. Turn ignition switch ON.
2. Make sure voltage between BCM harness connector M3 terminal 38 (W/L) and ground.

Terminal			Voltage
(+)		(-)	
Connector	Terminal (Wire color)	Ground	12V
M3	38 (W/L)		

OK or NG

- OK >> GO TO 4.
- NG >> Check BCM power supply circuit for open or short.

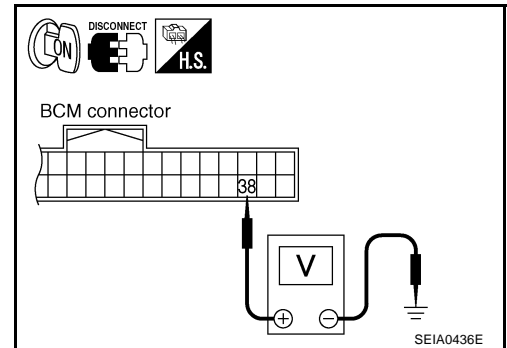

## 4. CHECK GROUND CIRCUIT

- Check continuity between BCM harness connector M4 terminal 49(B), 52 (B) and ground.

Terminal			Continuity
(+)		(-)	
Connector	Terminal (Wire color)	Ground	Should exist.
M4	49 (B), 52 (B)		

OK or NG

- OK >> Replace BCM. Refer to [BCS-16, "Removal and Installation of BCM"](#).
- NG >> Repair or replace BCM ground circuit.

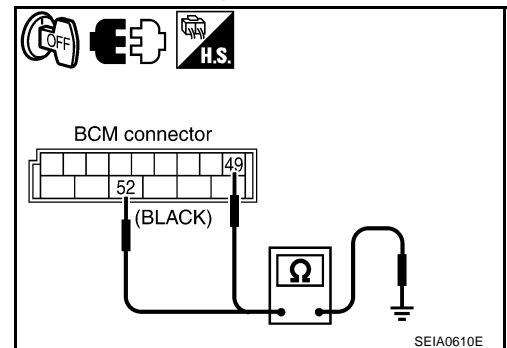



# TROUBLE DIAGNOSIS FOR SYMPTOMS

## Inspection 3: Warning Lamp Blinks When Ignition Switch Is Turned On

AES000ZH

### NOTE:

If warning lamp blink below, the system is normal.

Blink Mode A

- This mode shows transmitter status is OFF-mode. Perform transmitter wake up operation. Refer to [WT-18, "Transmitter Wake Up Operation"](#).

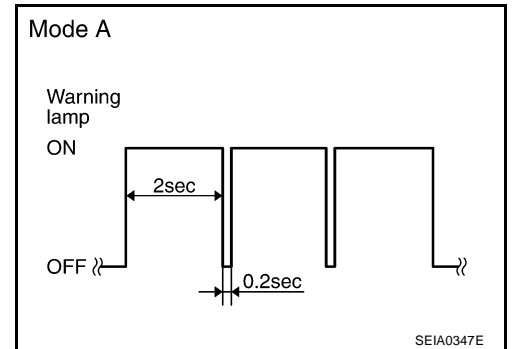

### DIAGNOSTIC PROCEDURE

#### 1. CHECK CONNECTOR

- Disconnect BCM harness connector M3.
- Check terminals for damage or loose connections.

OK or NG

- OK >> GO TO 2.
- NG >> Repair or replace damaged parts.

#### 2. CHECK TIRE PRESSURE WARNING CHECK SWITCH CIRCUIT

- Check continuity between BCM harness connector M3 terminal 15 (G) and ground.

Terminal		Continuity
(+)	(-)	
Connector	Terminal (Wire color)	Ground
M3	15 (G)	Should not exist.

OK or NG

- OK >> Replace BCM. Refer to [BCS-16, "Removal and Installation of BCM"](#).
- NG >> Repair or replace harness connector.

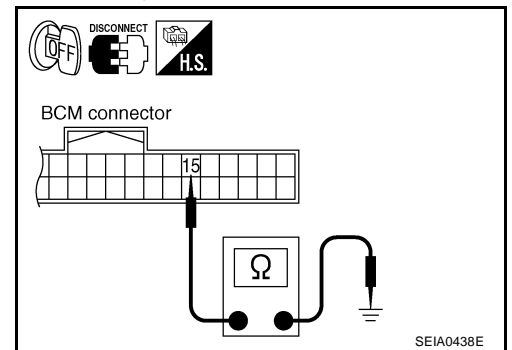

# TROUBLE DIAGNOSIS FOR SYMPTOMS

## Inspection 4: Turn Signal Lamp Blinks When Ignition Switch Is Turned On

AES000ZJ

### DIAGNOSTIC PROCEDURE

#### 1. CHECK TIRE PRESSURE WARNING CHECK SWITCH CIRCUIT

- Check continuity between BCM harness connector M3 terminal 15 (G) and ground.

Terminal		Continuity	
(+)	(-)		
Connector	Terminal (Wire color)	Ground	Should not exist.
M3	15 (G)		

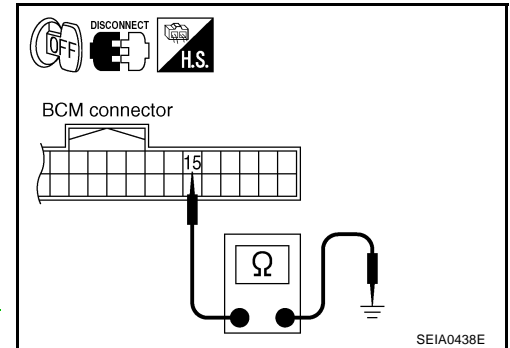

#### OK or NG

- OK >> Check turn signal lamp operation. Refer to [LT-91, "System Description"](#).
- NG >> Repair or replace harness connector.

## Inspection 5: ID Registration Can Not Be Completed

AES000ZJ

### DIAGNOSTIC PROCEDURE

#### 1. ID REGISTRATION (ALL)

- Perform ID registration of all transmitters.

Can ID registration of all transmitters be completed?

- YES >> INSPECTION END
- NO >> GO TO [WT-28, "TROUBLE DIAGNOSIS FOR SELF-DIAGNOSTIC ITEMS"](#).

# REMOVAL AND INSTALLATION

## REMOVAL AND INSTALLATION

PPF:00000

### Transmitter REMOVAL

AES000ZK

1. Deflate tire. Unscrew transmitter retaining nut and allow transmitter to fall into tire.
2. Gently bounce tire so that transmitter falls to bottom of tire. Place on tire changing machine and break both tire beads ensuring that the transmitter remains at the bottom of the tire.

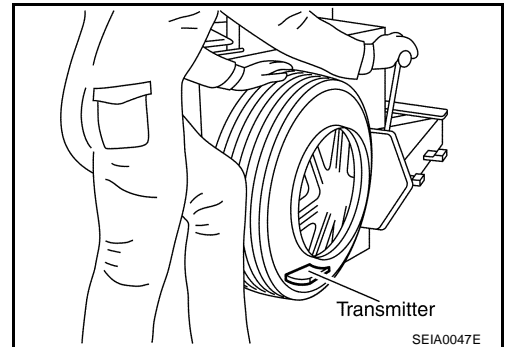

3. Turn tire so that valve hole is at bottom and bounce so that transmitter is near valve hole. Carefully lift tire onto turntable and position valve hole (and transmitter) 270 degree from mounting/dismounting head.
4. Lubricate tire well and remove first side of the tire. Reach inside the tire and remove the transmitter.

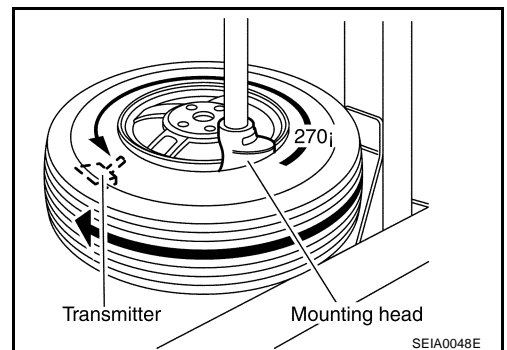

### INSTALLATION

1. Put first side of tire onto rim.
2. Mount transmitter on rim and tighten nut.

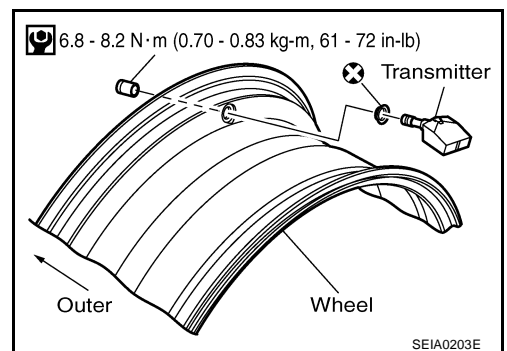
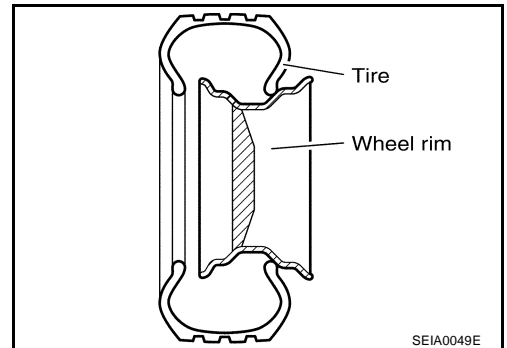

A  
B  
C  
D  
WT  
F  
G  
H  
I  
J  
K  
L  
M

## REMOVAL AND INSTALLATION

- Place wheel on turntable of tire machine. Ensure that transmitter is 270 degree from mounting head when second side of tire is fitted.

**NOTE:**

Do not touch transmitter at mounting head.

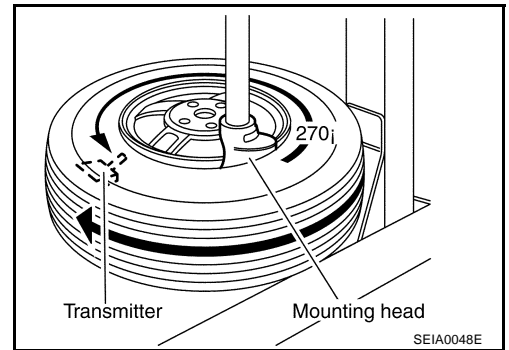

- Lubricate tire well and fit second side of tire as normal. Ensure that tire does not rotate relative to rim.
- Inflate tire and fit to appropriate wheel position.

# SERVICE DATA

## SERVICE DATA

PFP:00030

### Road Wheel

AES000KB

Kind of wheel		Aluminum	Steel (for emergency use)
Deflection limit	Lateral deflection	Less than 0.3 mm (0.01 in)	Less than 1.5 mm (0.06 in)
	Vertical deflection	Less than 0.3 mm (0.01 in)	Less than 1.5 mm (0.06 in)
Allowable quantity of residual unbalance	Dynamic (At rim flange)	Less than 5.0 g (0.2 oz) (per side)	—
	Static (At rim flange)	Less than 20 g (0.7 oz)	—

### Tire

AES000KC

Unit: kPa (kg/cm<sup>2</sup>, psi)

Tire size	Air pressure	
	Front wheel	Rear wheel
P265/60R18 109V	220 (2.2, 32)	220 (2.2, 32)
P265/50R20 106V	220 (2.2, 32)	220 (2.2, 32)
T175/90D18 110M	420 (4.2, 60)	420 (4.2, 60)

### Tightening Torque

AES000KD

Wheel nut	112.5 N·m (11 kg·m, 83 ft·lb)
-----------	-------------------------------

**SERVICE DATA**

---