

A
B
C
D
E

SECTION **BR** BRAKE SYSTEM

CONTENTS

<p>PRECAUTIONS 3</p> <p style="padding-left: 20px;">Precautions for Supplemental Restraint System (SRS) "AIR BAG" and "SEAT BELT PRE-TENSIONER" 3</p> <p style="padding-left: 20px;">Precautions for Procedures without Cowl Top Cover... 3</p> <p style="padding-left: 20px;">Precautions for Brake System 3</p> <p>PREPARATION 4</p> <p style="padding-left: 20px;">Commercial Service Tools 4</p> <p>NOISE, VIBRATION AND HARSHNESS (NVH)</p> <p>TROUBLESHOOTING 5</p> <p style="padding-left: 20px;">NVH Troubleshooting Chart 5</p> <p>BRAKE PEDAL 6</p> <p style="padding-left: 20px;">Inspection and Adjustment 6</p> <p style="padding-left: 40px;">PLAY AND CLEARANCE BETWEEN BRAKE PEDAL AND FLOOR PANEL WITH PEDAL DEPRESSED 6</p> <p style="padding-left: 40px;">ADJUSTMENT 7</p> <p style="padding-left: 20px;">Removal and Installation 7</p> <p style="padding-left: 40px;">COMPONENT PARTS LOCATION 7</p> <p style="padding-left: 40px;">REMOVAL 8</p> <p style="padding-left: 40px;">INSPECTION AFTER REMOVAL 8</p> <p style="padding-left: 40px;">INSTALLATION 8</p> <p>BRAKE FLUID 9</p> <p style="padding-left: 20px;">On-Board Inspection 9</p> <p style="padding-left: 40px;">LEVEL CHECK 9</p> <p style="padding-left: 20px;">Drain and Refill 9</p> <p style="padding-left: 20px;">Bleeding Brake System 10</p> <p>BRAKE PIPING AND HOSE 11</p> <p style="padding-left: 20px;">Hydraulic Circuit 11</p> <p style="padding-left: 20px;">Removal and Installation of Front Brake Piping and Brake Hose 11</p> <p style="padding-left: 40px;">REMOVAL 11</p> <p style="padding-left: 40px;">INSTALLATION 11</p> <p style="padding-left: 20px;">Removal and Installation of Rear Brake Piping and Brake Hose 12</p> <p style="padding-left: 40px;">REMOVAL 12</p> <p style="padding-left: 40px;">INSTALLATION 12</p> <p style="padding-left: 20px;">Inspection After Installation 12</p> <p>BRAKE MASTER CYLINDER 13</p> <p style="padding-left: 20px;">On-Board Inspection 13</p>	<p style="padding-left: 20px;">LEAK INSPECTION 13</p> <p style="padding-left: 20px;">Removal and Installation 13</p> <p style="padding-left: 40px;">REMOVAL 13</p> <p style="padding-left: 40px;">INSTALLATION 13</p> <p style="padding-left: 20px;">Components 13</p> <p style="padding-left: 20px;">Disassembly and Assembly 14</p> <p style="padding-left: 40px;">DISASSEMBLY 14</p> <p style="padding-left: 40px;">ASSEMBLY 14</p> <p>BRAKE BOOSTER 15</p> <p style="padding-left: 20px;">On-Vehicle Service 15</p> <p style="padding-left: 40px;">OPERATING CHECK 15</p> <p style="padding-left: 40px;">AIRTIGHT CHECK 15</p> <p style="padding-left: 20px;">Removal and Installation 16</p> <p style="padding-left: 40px;">REMOVAL 16</p> <p style="padding-left: 40px;">INSPECTION AFTER REMOVAL 16</p> <p style="padding-left: 40px;">INSTALLATION 17</p> <p>VACUUM LINES 18</p> <p style="padding-left: 20px;">Removal and Installation 18</p> <p style="padding-left: 20px;">Inspection 18</p> <p style="padding-left: 40px;">VISUAL INSPECTION 18</p> <p style="padding-left: 40px;">CHECK VALVE INSPECTION 19</p> <p>FRONT DISC BRAKE 20</p> <p style="padding-left: 20px;">On-Vehicle Inspection 20</p> <p style="padding-left: 40px;">PAD WEAR INSPECTION 20</p> <p style="padding-left: 20px;">Components 20</p> <p style="padding-left: 20px;">Removal and Installation of Brake Pad 21</p> <p style="padding-left: 40px;">REMOVAL 21</p> <p style="padding-left: 40px;">INSTALLATION 21</p> <p style="padding-left: 20px;">Removal and Installation of Brake Caliper Assembly 21</p> <p style="padding-left: 40px;">REMOVAL 21</p> <p style="padding-left: 40px;">INSTALLATION 21</p> <p style="padding-left: 20px;">Disassembly and Assembly of Brake Caliper Assembly 22</p> <p style="padding-left: 40px;">DISASSEMBLY 22</p> <p style="padding-left: 40px;">CALIPER INSPECTION 23</p> <p style="padding-left: 40px;">ASSEMBLY 23</p> <p style="padding-left: 40px;">DISC ROTOR INSPECTION 24</p> <p style="padding-left: 40px;">BRAKE BURNISHING PROCEDURE 25</p> <p>REAR DISC BRAKE 26</p>
--	--

BR
G
H
I
J
K
L
M

On-Vehicle Inspection	26	Assembly	28
PAD WEAR INSPECTION	26	DISASSEMBLY	28
Components	26	CALIPER INSPECTION	29
Removal and Installation of Brake Pad	27	ASSEMBLY	29
REMOVAL	27	DISC ROTOR INSPECTION	30
INSTALLATION	27	BRAKE BURNISHING PROCEDURE	31
Removal and Installation of Brake Caliper Assembly		SERVICE DATA AND SPECIFICATIONS (SDS)	32
REMOVAL	27	General Specifications	32
INSTALLATION	28	Brake Pedal	32
Disassembly and Assembly of Brake Caliper		Brake Booster	32
		Check Valve	32
		Front Disc Brake	32
		Rear Disc Brake	32

PRECAUTIONS

PRECAUTIONS

PFP:00001

Precautions for Supplemental Restraint System (SRS) “AIR BAG” and “SEAT BELT PRE-TENSIONER”

AFS0028A

The Supplemental Restraint System such as “AIR BAG” and “SEAT BELT PRE-TENSIONER”, used along with a front seat belt, helps to reduce the risk or severity of injury to the driver and front passenger for certain types of collision. This system includes seat belt switch inputs and dual stage front air bag modules. The SRS system uses the seat belt switches to determine the front air bag deployment, and may only deploy one front air bag, depending on the severity of a collision and whether the front occupants are belted or unbelted. Information necessary to service the system safely is included in the SRS and SB section of this Service Manual.

WARNING:

- To avoid rendering the SRS inoperative, which could increase the risk of personal injury or death in the event of a collision which would result in air bag inflation, all maintenance must be performed by an authorized NISSAN/INFINITI dealer.
- Improper maintenance, including incorrect removal and installation of the SRS, can lead to personal injury caused by unintentional activation of the system. For removal of Spiral Cable and Air Bag Module, see the SRS section.
- Do not use electrical test equipment on any circuit related to the SRS unless instructed to in this Service Manual. SRS wiring harnesses can be identified by yellow and/or orange harnesses or harness connectors.

Precautions for Procedures without Cowl Top Cover

AFS0038B

When performing the procedure after removing cowl top cover, cover the lower end of windshield with urethane, etc.

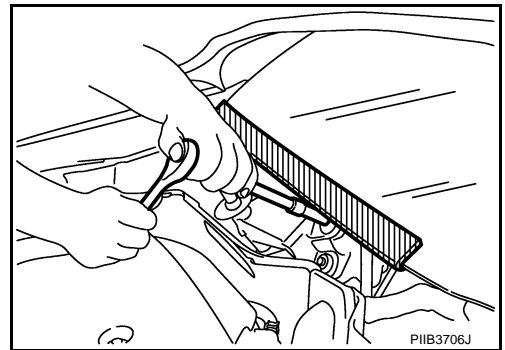

Precautions for Brake System

AFS001M0

- Recommended fluid is brake fluid “DOT 3”.
- Do not reuse drained brake fluid.
- Be careful not to splash brake fluid on painted areas.
- To clean or wash all parts of master cylinder, disc brake caliper and wheel cylinder, use clean brake fluid.
- Do not use mineral oils such as gasoline or kerosene. They will ruin rubber parts of the hydraulic system.
- Use flare nut wrench when removing and installing brake tube.
- When installing brake piping, be sure to check torque.
- Before working, turn ignition switch OFF and disconnect connectors for ABS actuator and electric unit (control unit) or battery terminal.
- Burnish the brake contact surfaces after refinishing or replacing drums or rotors, after replacing pads or linings, or if a soft pedal occurs at very low mileage.
Refer to [BR-25, "BRAKE BURNISHING PROCEDURE"](#).

WARNING:

- Clean brake pads and shoes with a waste cloth, then wipe with a dust collector.

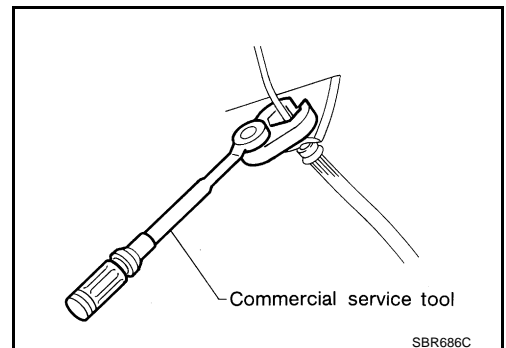

PREPARATION

PREPARATION

PFP:00002

Commercial Service Tools

AFS001MR

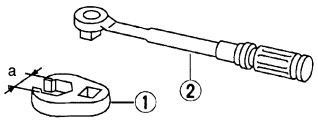
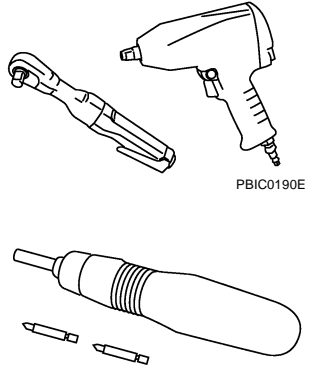
Tool name	Description
<p>1. Flare nut crowfoot a:10 mm (0.39 in) / 12 mm (0.47 in)</p> <p>2. Torque wrench</p>	 <p>S-NT360</p> <p>Removing and installing each brake piping</p>
<p>Power tool</p>	 <p>PBIC0190E</p> <p>PBIC0191E</p> <p>Removing front and rear caliper assembly, tires</p>

BRAKE PEDAL

BRAKE PEDAL

PF:46501

Inspection and Adjustment

AFS001MT

PLAY AND CLEARANCE BETWEEN BRAKE PEDAL AND FLOOR PANEL WITH PEDAL DEPRESSED

1. Check brake pedal height from dash lower panel.
2. Adjust height referring to the following specifications.

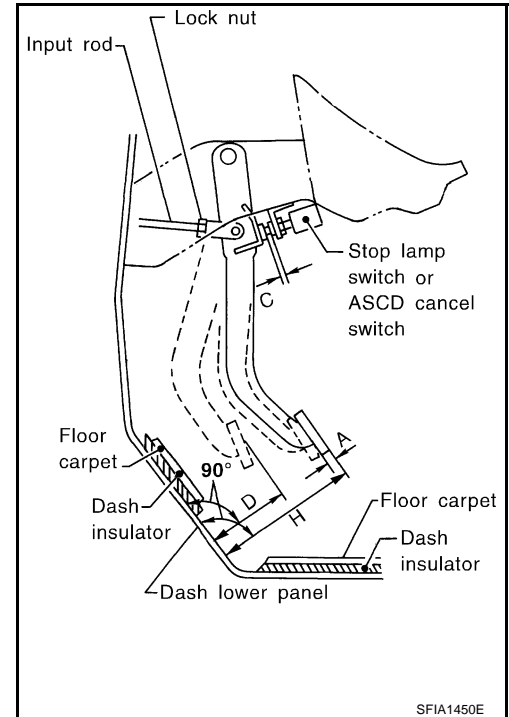

H	Brake pedal free height (from dash lower panel top surface)	161.5 – 171.5 mm (6.36 – 6.75 in)
D	Brake pedal depressed height [under a force of 490 N (50 kg, 110 lb) with engine running]	More than 80 mm (3.15 in)
C	Clearance between bracket and the threaded end of stop lamp switch or ASCD cancel switch (or brake switch)	0.74 – 1.96 mm (0.0291 – 0.0772 in)
A	Pedal play	3 – 11 mm (0.12 – 0.43 in)

BRAKE PEDAL

ADJUSTMENT

1. Loosen stop lamp switch and ASCD cancel switch (or brake switch) by turning it counterclockwise by 45°.
2. Loosen lock nut (A) on input rod, then rotate input rod to set pedal to the specified height, and tighten lock nut (A).

CAUTION:

Make sure the threaded end of input rod stays inside clevis.

Lock nut (A) 

Refer to [BR-16](#), "Removal and Installation"

3. With pedal pulled and held by hand, press stop lamp switch and ASCD cancel switch (or brake switch) until its threaded end contacts stopper rubber.
4. With the threaded end of stop lamp switch and ASCD cancel switch (or brake switch) contacting stopper rubber, rotate switch clockwise by 45° to secure.

CAUTION:

Make sure that the clearance (C) between stopper rubber and threaded end of stop lamp switch and ASCD cancel switch (or brake switch) is within the standard.

5. Check pedal play.

CAUTION:

Make sure that stop lamps go off when pedal is released.

6. Start engine to check brake pedal depressed height.

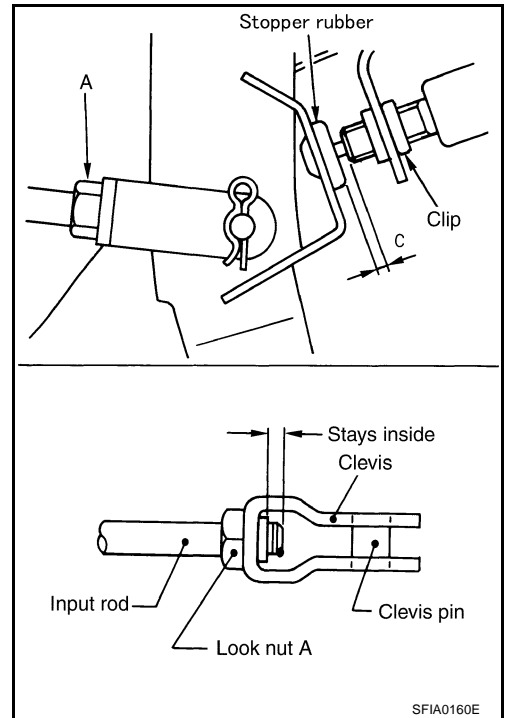

Removal and Installation COMPONENT PARTS LOCATION

AFS001MU

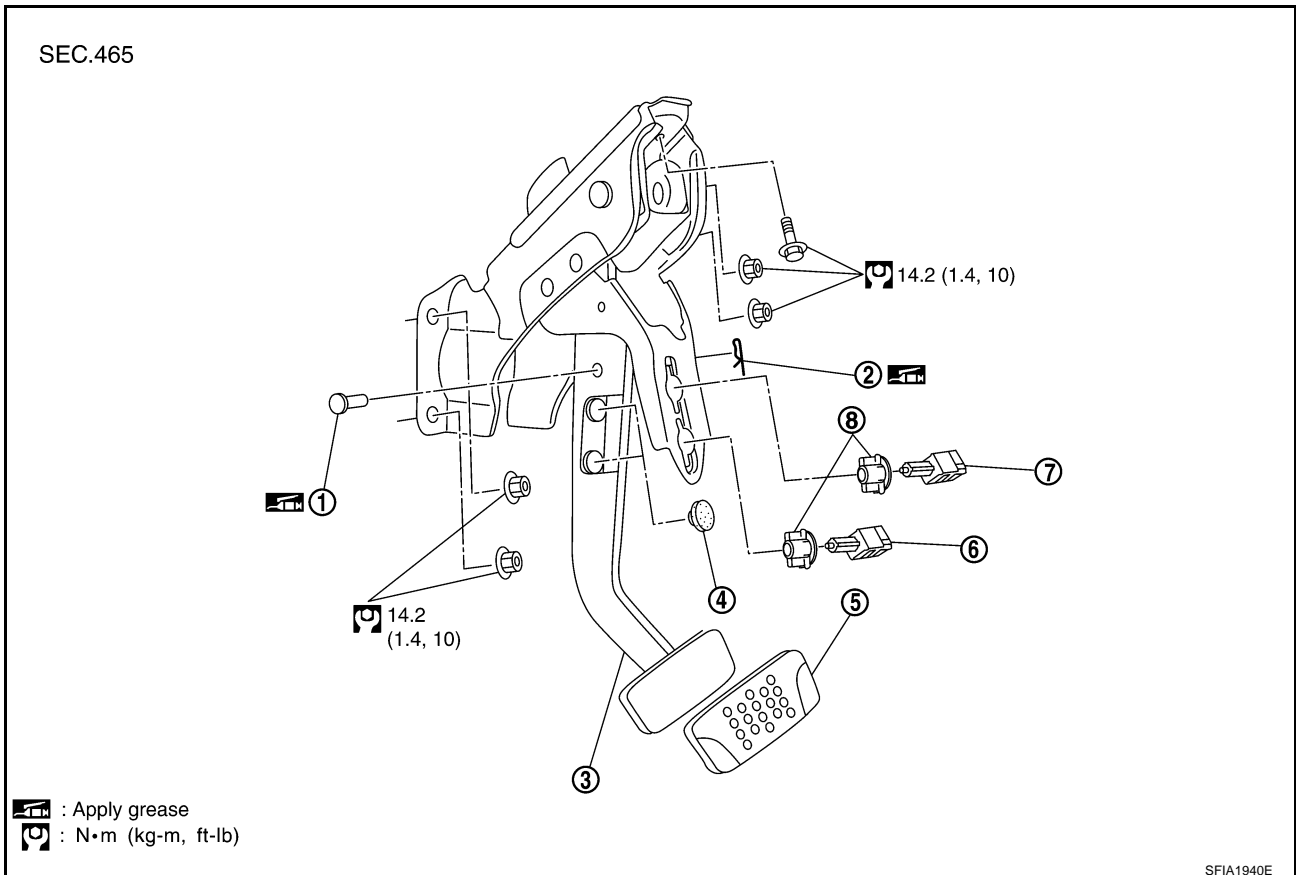

BRAKE PEDAL

1. Clevis pin
2. Snap pin
3. Brake pedal assembly
4. Stopper rubber
5. Pedal pad
6. ASCD cancel switch (Models with ASCD)
Brake switch (Models with ACC)
7. Stop lamp switch
8. Clip

REMOVAL

1. Remove front kicking plate (driver side). [EI-38, "KICKING PLATE"](#) .
2. Remove dash side finisher (driver side). [EI-37, "DASH SIDE FINISHER"](#) .
3. Remove instrument lower panel (driver side). [IP-18, "INSTRUMENT PASSENGER LOWER PANEL"](#) .
4. Remove steering column assembly. Refer to [PS-12, "Removal and Installation"](#) .
5. Remove stop lamp switch and ASCD cancel switch (or brake switch) from pedal assembly.
6. Remove snap pin and clevis pin from brake booster clevis.
7. Remove mounting nuts and bolts from bracket, and remove pedal assembly from the vehicle.

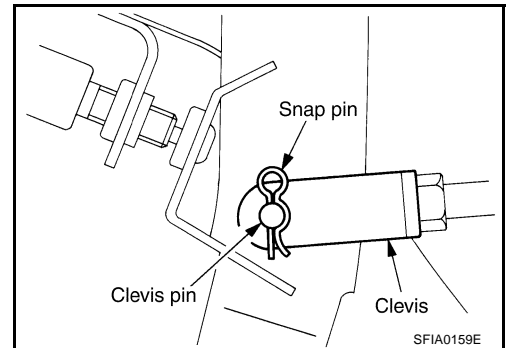

INSPECTION AFTER REMOVAL

- Make sure the rivets in the upper part of brake pedal are not deformed.
- Make sure sub bracket and slide plate are at least 4 mm (0.16 in) apart.

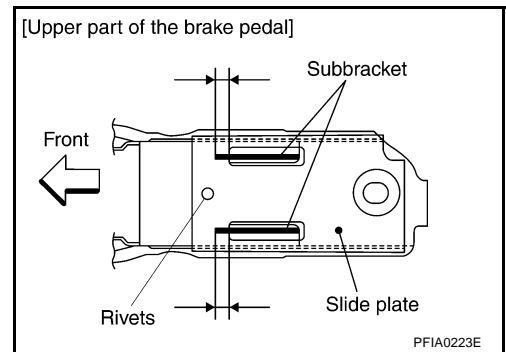

- Check brake pedal for bend, damage, and cracks on the welded parts. Replace the applicable part if a malfunction is detected.
- Check clevis pin and resin stopper for damage and deformation. If a malfunction is detected, replace clevis pin.

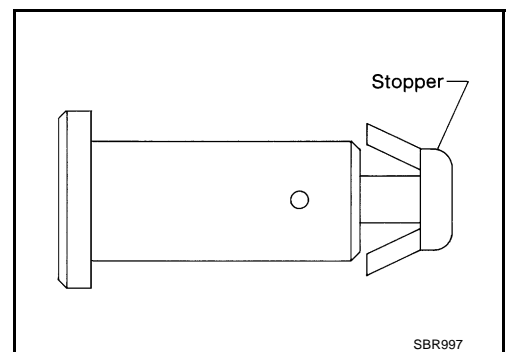

INSTALLATION

Note the following, and install in the reverse order of removal.

- After installing brake pedal assembly to the vehicle, adjust brake pedal height.

BRAKE FLUID

BRAKE FLUID

PFK:KN100

On-Board Inspection LEVEL CHECK

AFS001MV

- Make sure the fluid level in reservoir tank is within the standard (between MAX and MIN lines).
- Visually check around reservoir tank for fluid leaks.
- If fluid level is excessively low, check brake system for leaks.
- If brake warning lamp remains illuminated after parking lever is released, check brake system for fluid leakage.

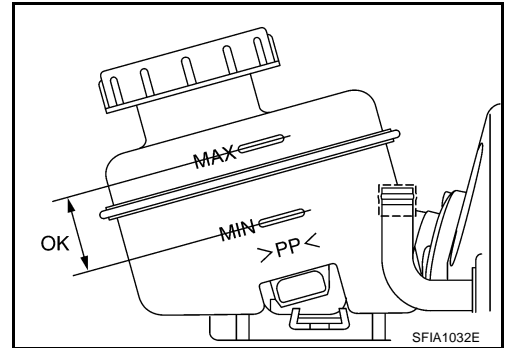

Drain and Refill

AFS001MW

CAUTION:

- Refill with new brake fluid "DOT3".
 - Do not reuse drained brake fluid.
 - Do not let brake fluid splash on the painted surfaces of the body. This might damage the paint, so when splashing it, immediately wipe off the area and wash away with water.
 - Before servicing, disconnect actuator connector or battery negative cable.
1. Connect a vinyl tube to each bleed valve.
 2. Depress brake pedal, loosen each bleed valve, and gradually remove brake fluid.

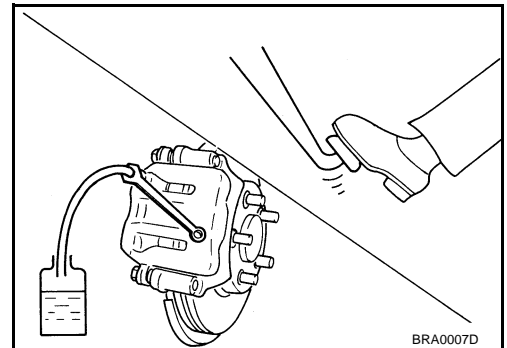

3. Make sure there is no foreign material in reservoir tank, and refill with new brake fluid.
4. Rest foot on brake pedal. Loosen bleed valve. Slowly depress pedal until it stops. Tighten bleed valve. Release brake pedal. Repeat this process a few times, then pause to add new brake fluid to master cylinder. Continue until new brake fluid flows out. Bleed Air. Refer to [BR-10, "Bleeding Brake System"](#) .

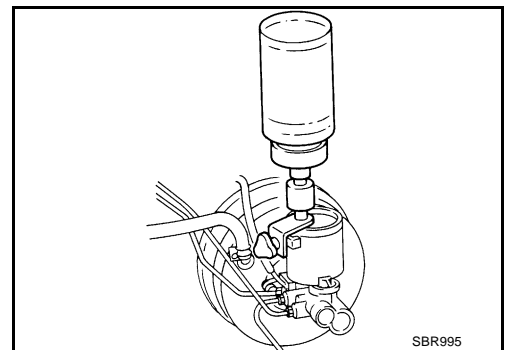

A
B
C
D
E
BR

G
H
I
J
K
L
M

Bleeding Brake System

AFS001MX

CAUTION:

While bleeding, pay attention to master cylinder fluid level.

1. Turn ignition switch OFF and disconnect ABS actuator and electric unit (control unit) connector or battery negative terminal.
2. Connect a vinyl tube to the rear right bleed valve.
3. Fully depress brake pedal 4 to 5 times.
4. With brake pedal depressed, loosen bleed valve to let the air out, and then tighten it immediately.
5. Repeat steps 3, 4 until no more air comes out.
6. Tighten bleed valve to the specified torque. Refer to [BR-20, "Components"](#) (front disc brake), [BR-26, "Components"](#) (rear disc brake).
7. In steps 2 to 6 below, with master cylinder reservoir tank filled at least half way, bleed air from the front left, rear left, and front right bleed valve, in that order.

BRAKE PIPING AND HOSE

BRAKE PIPING AND HOSE

PF0:46210

Hydraulic Circuit

AFS001MY

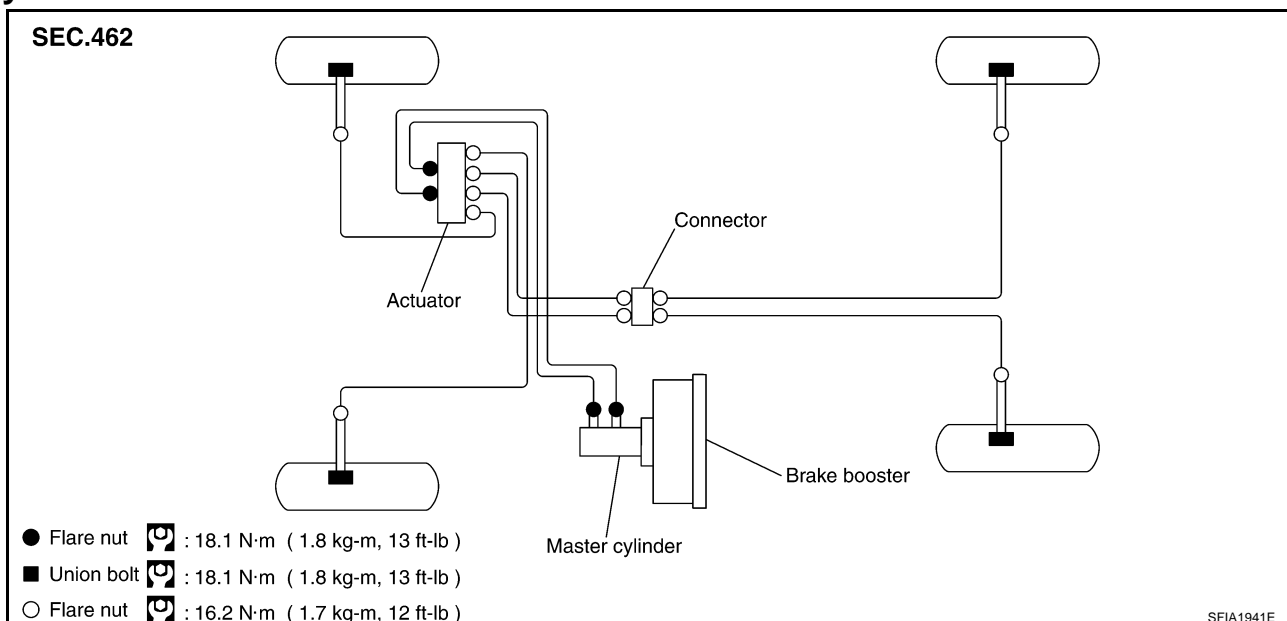

CAUTION:

- All hoses and piping (tubes) must be free from excessive bending, twisting and pulling.
- Make sure there is no interference with other parts when turning steering both clockwise and counterclockwise.
- The brake piping is an important safety part. If a brake fluid leak is detected, always disassemble the parts. Replace applicable part with a new one, if necessary.
- Be careful not to splash brake fluid on painted areas; it may cause paint damage. If brake fluid is splashed on painted areas, wash it away with water immediately.
- Do not bend or twist brake hose sharply, or strongly pull it.
- When removing components, cover connections so that no dirt, dust, or other foreign matter gets in.
- Refill with new brake fluid " DOT 3 ".
- Do not reuse drained brake fluid.

Removal and Installation of Front Brake Piping and Brake Hose

AFS001MZ

REMOVAL

1. Drain brake fluid. Refer to [BR-9, "Drain and Refill"](#) .
2. Using a flare nut wrench, remove brake tube from brake hose.
3. Remove union bolt and remove brake hose from caliper assembly.
4. Remove lock plate and remove brake hose from the vehicle.

INSTALLATION

1. Install brake hose by aligning with the protrusion on caliper assembly, and tighten union bolt to the specified torque.

NOTE:

Do not reuse copper washer.

2. Install brake hose to brake tube, partially tighten flare nut as far as possible by hand, then secure it to bracket with lock plate.
3. Using a flare nut wrench, tighten flare nut to the specified torque.
4. Refill brake fluid and bleed air. Refer to [BR-10, "Bleeding Brake System"](#) .

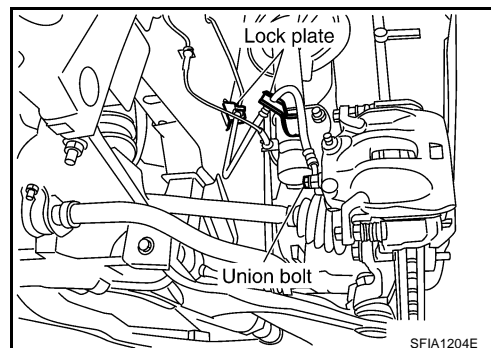

BRAKE PIPING AND HOSE

Removal and Installation of Rear Brake Piping and Brake Hose

AFS001N0

REMOVAL

1. Drain brake fluid. Refer to [BR-9, "Drain and Refill"](#) .
2. Using a flare nut wrench, remove brake tube from brake hose.
3. Remove bolt.
4. Remove union bolt, and then remove brake hose from caliper assembly.

INSTALLATION

1. Install brake hose to caliper assembly positioning hole and tighten union bolt to the specified torque.

NOTE:

Do not reuse copper washer.

2. Install brake hose to brake tube, partially tighten flare nut as far as possible by hand, then tighten bolt to the specified torque.

 : 23.5 N·m (2.4 kg-m, 17 ft-lb)

3. Using a flare nut wrench, tighten flare nut to the specified torque.
4. Refill brake fluid and bleed air. Refer to [BR-10, "Bleeding Brake System"](#) .

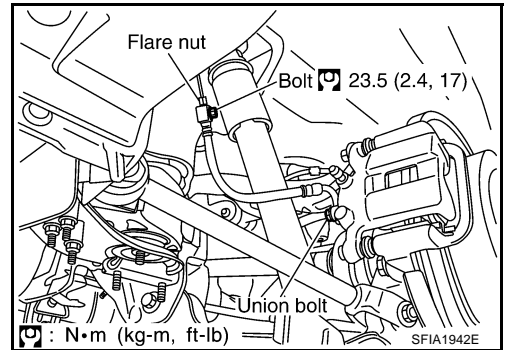

Inspection After Installation

AFS001N1

CAUTION:

If a leak is detected at the connections, retighten it or, if necessary, replace the damaged part.

1. Check brake lines (tubes and hoses), and connections for fluid leaks, damage, twist, deformation, contact with other parts, and loose connections. Replace any damage parts.
2. While depressing brake pedal under a force of 785 N (80 kg, 177 lb) with engine running for approximately 5 seconds, check for fluid leakage from each part.

BRAKE MASTER CYLINDER

BRAKE MASTER CYLINDER

PFP:46010

On-Board Inspection LEAK INSPECTION

AFS001N2

- Check for leaking in master cylinder attachment portion, reservoir tank, and brake tube connections.

Removal and Installation

AFS001N3

CAUTION:

Be careful not to splash brake fluid on painted areas; it may cause paint damage. If brake fluid is splashed on painted areas, wash it away with water immediately.

REMOVAL

1. Drain brake fluid. Refer to [BR-9, "Drain and Refill"](#).
2. Disconnect harness connectors for fluid level sensor and pressure sensor.
3. Using a flare nut wrench, disconnect brake tube from master cylinder assembly.
4. Remove master cylinder assembly fixing nut, remove master cylinder assembly from the vehicle. Refer to [BR-16, "Removal and Installation"](#).

INSTALLATION

- Install in the reverse order of removal.
- Refill brake fluid and bleed air. Refer to [BR-10, "Bleeding Brake System"](#).

CAUTION:

- Refill with new brake fluid "DOT3".
- Do not reuse drained brake fluid.

Components

AFS001N4

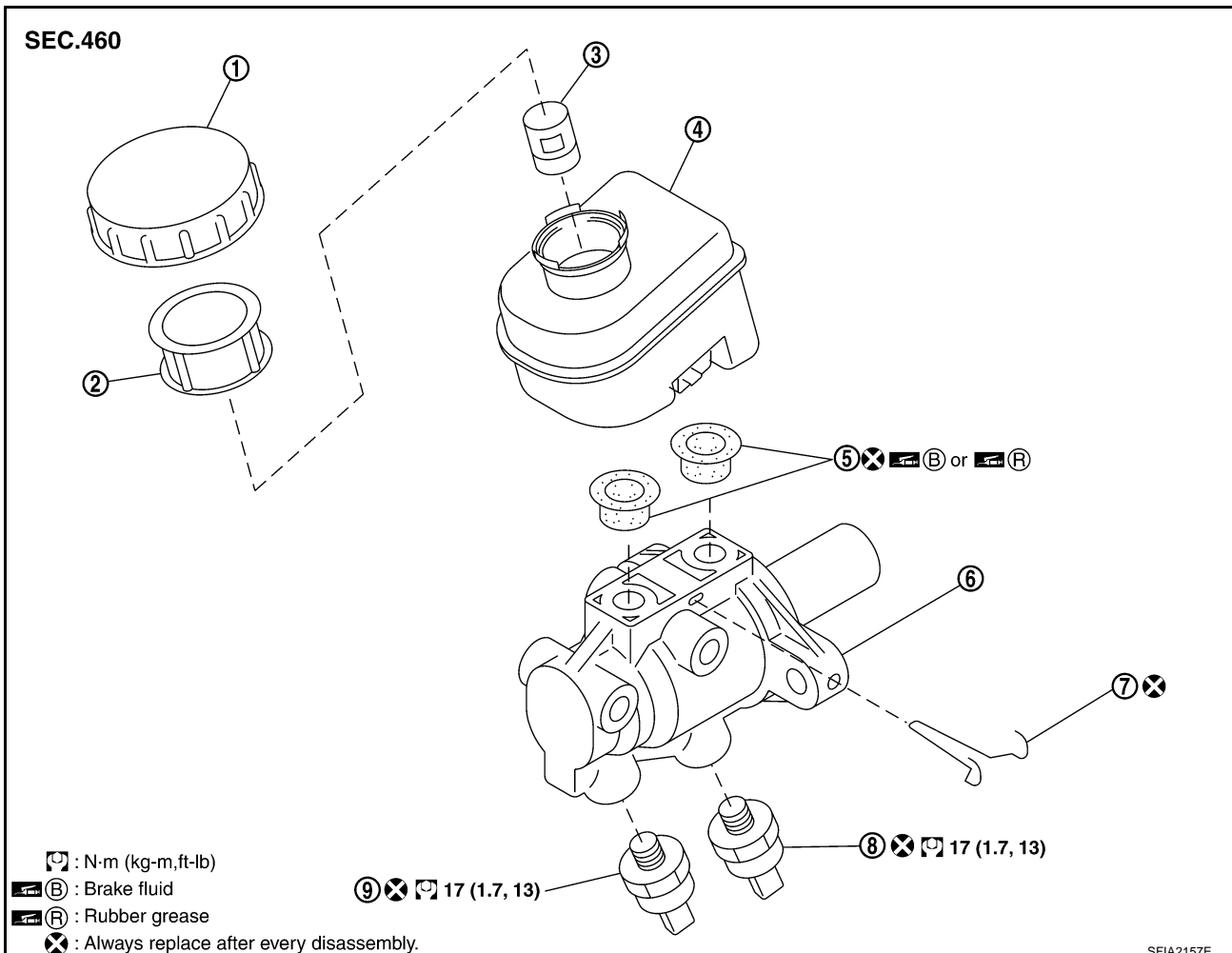

BRAKE MASTER CYLINDER

- | | | |
|-------------------|--------------------|--------------------------------------|
| 1. Reservoir cap | 2. Strainer | 3. Float |
| 4. Reservoir tank | 5. Grommet | 6. Master cylinder sub-assembly |
| 7. Clip | 8. Pressure sensor | 9. Pressure sensor (Only ICC models) |

Disassembly and Assembly

AFS001N5

CAUTION:

- Master cylinder can not be disassembled.
- Remove reservoir tank only when absolutely necessary.

1. Remove clip.
2. Remove reservoir tank and grommet from master cylinder assembly.

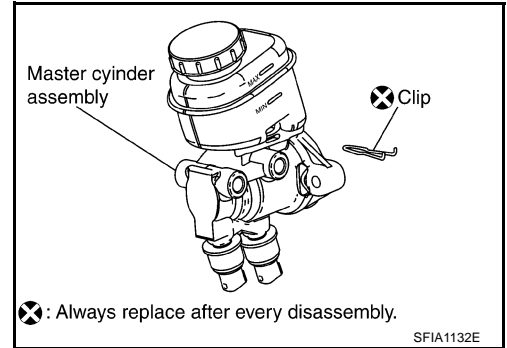

ASSEMBLY

CAUTION:

- Never use mineral oil such as kerosene, gasoline during the cleaning and assembly process.
- Do not drop parts. If a part is dropped, do not use it.

1. Apply brake fluid grommet and attach to master cylinder assembly.

CAUTION:

Do not reuse grommet.

2. Install reservoir tank onto master cylinder assembly.
3. Install clip.

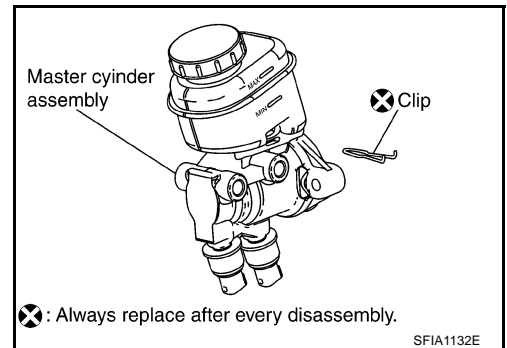

BRAKE BOOSTER

BRAKE BOOSTER

PFP:47200

On-Vehicle Service OPERATING CHECK

AFS001N6

With engine stopped, change the vacuum to the atmospheric pressure by depressing brake pedal several times. Then with brake pedal fully depressed, start engine and when the vacuum pressure reaches the standard, make sure the clearance between brake pedal and floor panel decreases.

CAUTION:

Depressing pedal interval is approximately 5 seconds.

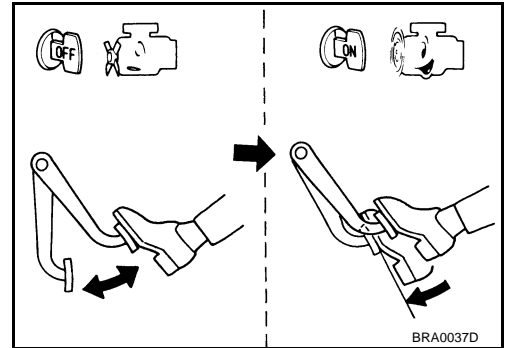

AIRTIGHT CHECK

- Run engine at idle for approximately 1 minute, and stop it after applying vacuum to booster. Depress brake pedal normally to change the vacuum to the atmospheric pressure. Make sure distance between brake pedal and floor panel gradually increases.
- Depress brake pedal while engine is running, and stop engine with pedal depressed. The pedal stroke should not change after holding pedal down for 30 seconds.

CAUTION:

Depressing pedal interval is approximately 5 seconds.

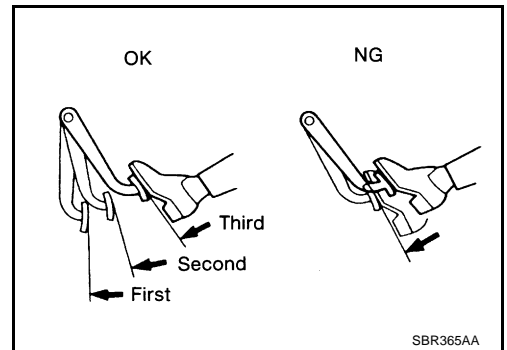

BRAKE BOOSTER

Removal and Installation

AFS001N7

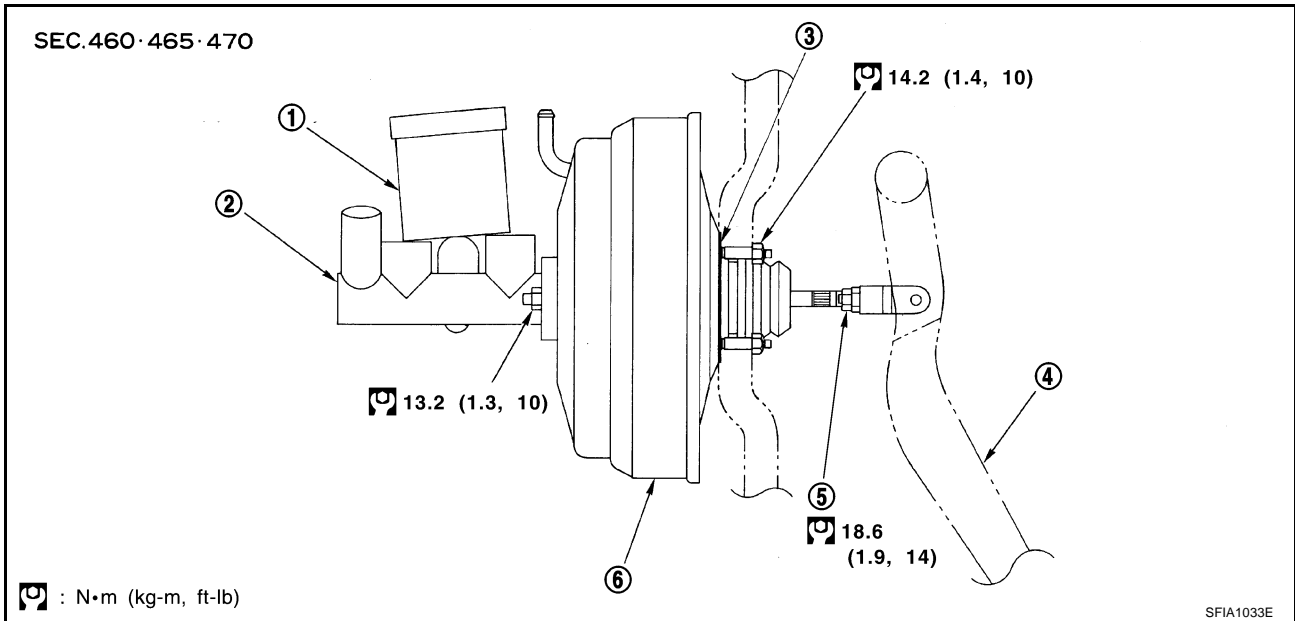

- | | | |
|-------------------|--------------------|------------------|
| 1. Reservoir tank | 2. Master cylinder | 3. Gasket |
| 4. Brake pedal | 5. Lock nut | 6. Brake booster |

REMOVAL

CAUTION:

- Be careful not to deform or bend brake piping while removing and installing brake booster.
- Replace clevis pin if it is damaged.
- Be careful not to damage brake booster stud bolt threads. If brake booster is tilted or inclined during installation, dash panel may damage the threads.
- Attach the check valve in the correct direction.

1. Remove brake piping from brake master cylinder.
2. Remove brake master cylinder. Refer to [BR-13, "Removal and Installation"](#).
3. Remove vacuum hose from brake booster. Refer to [BR-18, "VACUUM LINES"](#).
4. Disconnect harness connector from brake booster assembly. (ICC model)
5. Remove brake pedal attachment snap pin and clevis pin from inside the vehicle.
6. Remove nuts on brake booster and brake pedal assembly.
7. Remove brake booster assembly from dash panel.

INSPECTION AFTER REMOVAL

Output Rod Length Inspection

1. Using a handy vacuum pump, apply a vacuum of -66.7 kPa (-500 mmHg, -19.69 inHg) to brake booster.
2. Check output rod length.

Standard dimension when applying a vacuum of -66.7 kPa (500 mmHg, -19.69 inHg):
15.6 – 15.9 mm (0.614 – 0.626 in)

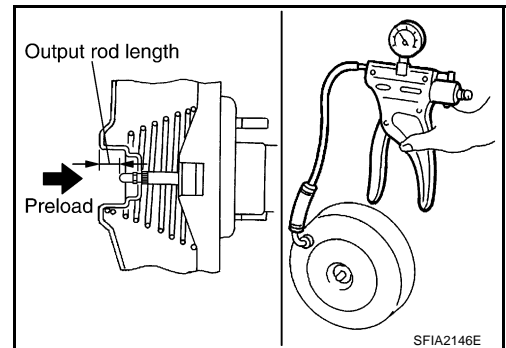

BRAKE BOOSTER

INSTALLATION

1. Loosen lock nut to adjust input rod length so that the length B (in the figure) satisfies the specified value.

Length "B" : 126.5 mm (4.98 in)

2. After adjusting "B", temporarily tighten lock nut to install booster assembly to the vehicle. At this time, make sure to install a gasket between booster assembly and the dash panel.
3. Connect brake pedal with clevis of input rod.
4. Install pedal bracket mounting nuts and tighten them to the specified torque.
5. Install brake piping from brake master cylinder to ABS actuator. Refer to [BR-11, "Hydraulic Circuit"](#).
6. Install master cylinder to booster assembly. Refer to [BR-16, "Removal and Installation"](#).
7. Adjust the height and play of brake pedal.
8. Tighten lock nut of input rod to the specified torque.
9. Refill new brake fluid and bleed air. Refer to [BR-10, "Bleeding Brake System"](#).

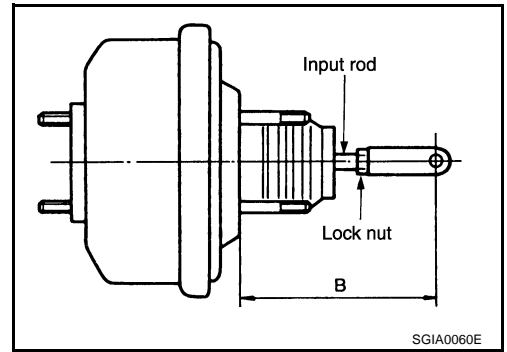

A
B
C
D
E
BR
G
H
I
J
K
L
M

VACUUM LINES

VACUUM LINES

PFP:41920

Removal and Installation

AFS001N8

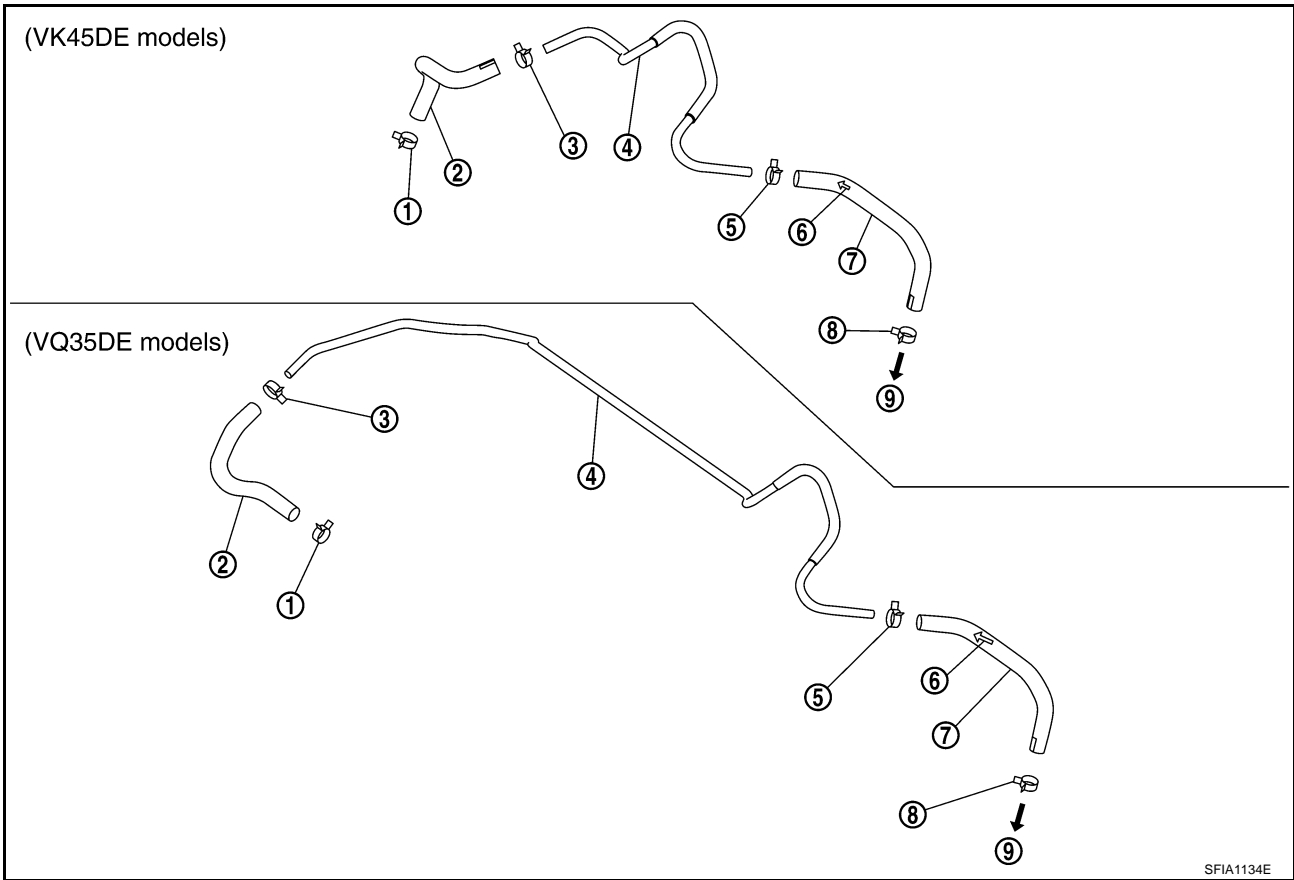

- | | | |
|------------------|----------------|---|
| 1. Clamp | 2. Vacuum hose | 3. Clamp |
| 4. Vacuum piping | 5. Clamp | 6. Check valve inclusion position stamp |
| 7. Vacuum hose | 8. Clamp | 9. Brake booster |

CAUTION:

- Because vacuum hose contains a check valve, it must be installed in the correct direction. Refer to the stamp or label to confirm correct installation. The brake booster will not operate normally if hose is installed in the wrong direction.
- Insert vacuum hose for at least 24 mm (0.94 in).
- Do not use lubricating oil during assembly.

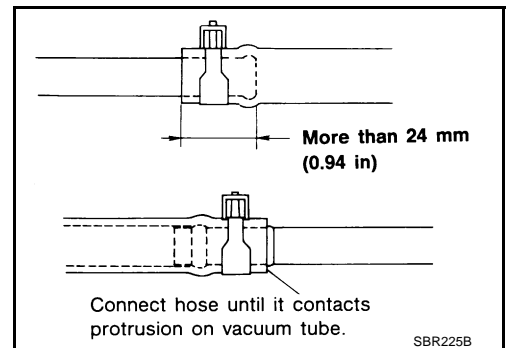

Inspection VISUAL INSPECTION

Check for improper assembly, damage and deterioration.

AFS001N9

VACUUM LINES

CHECK VALVE INSPECTION

Airtightness Inspection

Use a handy vacuum pump to check.

When connected to booster side (1):

Vacuum decrease should be within 1.3 kPa (10 mmHg, 0.39 inHg) for 15 seconds under a vacuum of -66.7 kPa (-500 mmHg, -19.69 inHg)

When connected to engine side (2):

No vacuum will be applied

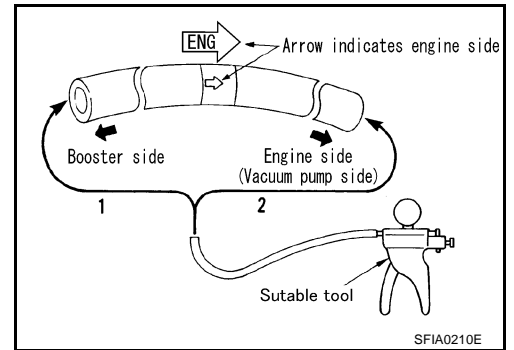

A
B
C
D
E

BR

G
H
I
J
K
L
M

FRONT DISC BRAKE

FRONT DISC BRAKE

PFP:41000

On-Vehicle Inspection PAD WEAR INSPECTION

AFS001RX

- Inspect the thickness of pad through cylinder body inspection hole. Use a scale for inspection if necessary.

Standard thickness : 9.5 mm (0.374 in)

Repair limit thickness : 2.0 mm (0.079 in)

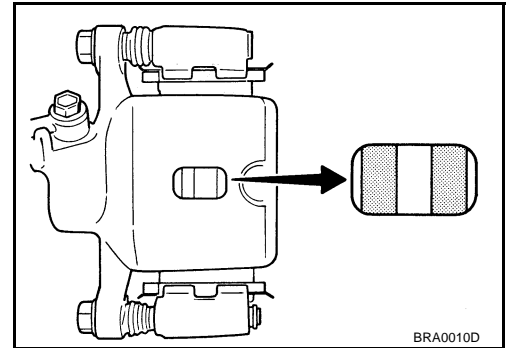

BRA0010D

Components

AFS001RY

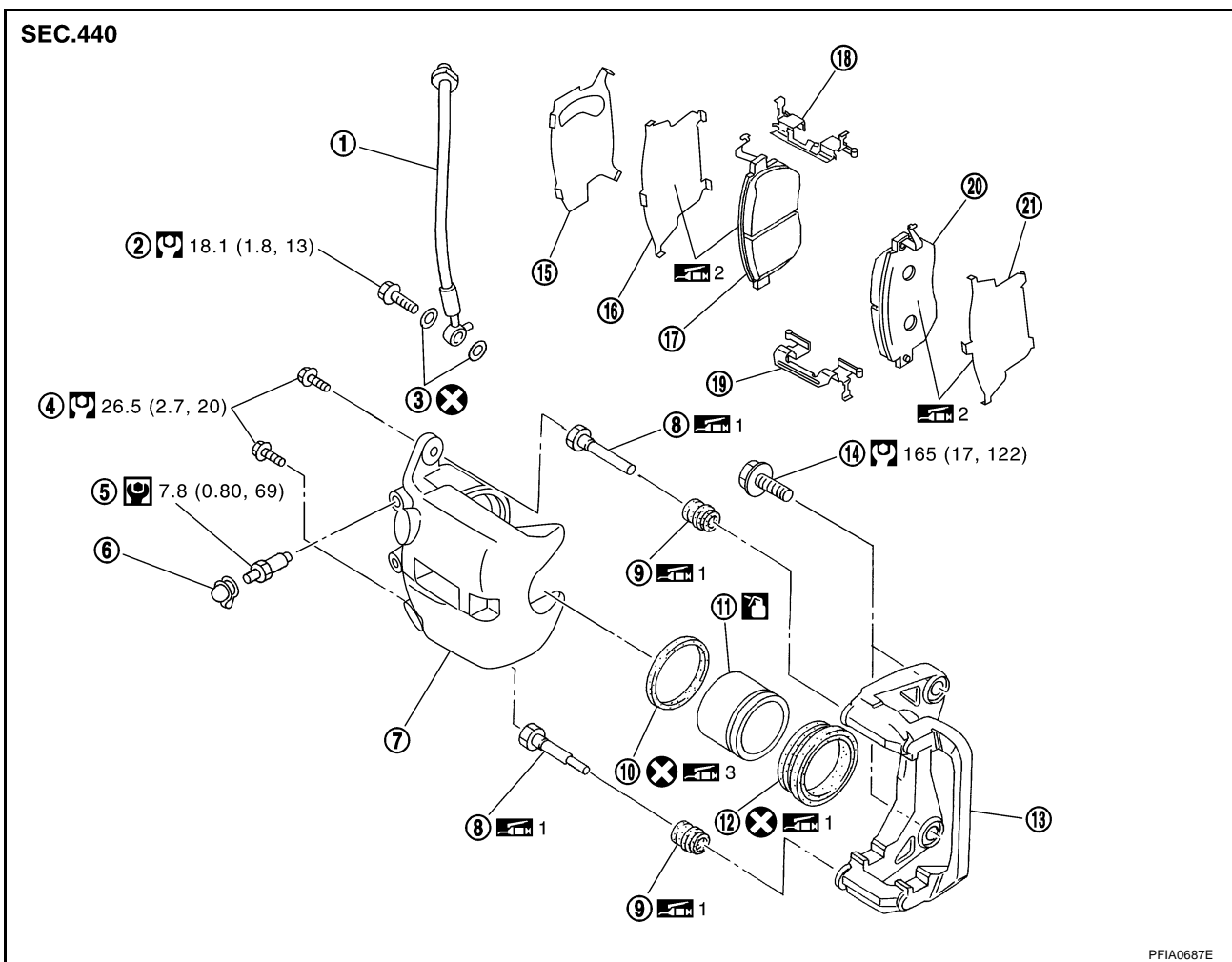

PFIA0687E

- | | | |
|--------------------------|------------------------|--------------------------|
| 1. Brake hose | 2. Union bolt | 3. Copper washer |
| 4. Sliding pin bolt | 5. Bleed valve | 6. Cap |
| 7. Cylinder body | 8. Sliding pin | 9. Sliding pin boot |
| 10. Piston seal | 11. Piston | 12. Piston boot |
| 13. Torque member | 14. Torque member bolt | 15. Inner shim cover |
| 16. Inner shim | 17. Inner pad | 18. Pad retainer (Upper) |
| 19. Pad retainer (Lower) | 20. Outer pad | 21. Outer shim |

Refer to [GI-10. "Components"](#) and the followings for the symbols in the figure.

1: Rubber grease

FRONT DISC BRAKE

 2: PBC (Poly Butyl Cuprysil) grease or silicone-based grease

 3: Polyglycol ether based lubricant

 : Brake fluid

WARNING:

Clean dust on caliper and brake pad with a vacuum dust collector to minimize the hazard of airborne particles or other materials.

CAUTION:

- While removing cylinder body never depress brake pedal because piston will pop out.
- It is not necessary to remove bolts on torque member and brake hose except for disassembly or replacement of caliper assembly. In this case, hang cylinder body with a wire so as not to stretch brake hose.
- Do not damage piston boot.
- If any shim is subject to serious corrosion, replace it with a new one.
- Always replace shims and shim covers as a set when replacing brake pads.
- Burnish brake contact surface after refinishing or replacing rotors, after replacing pads, or if a soft pedal occurs at very low mileage. Refer to [BR-25, "BRAKE BURNISHING PROCEDURE"](#) .

Removal and Installation of Brake Pad

AFS001RZ

REMOVAL

1. Remove tires from vehicle with power tool.
2. Remove lower sliding pin bolt.
3. Suspend cylinder body with a wire and remove pad and shim from torque member.

INSTALLATION

1. Attach inner shim and shim cover to inner pad, and outer shim to outer pad.
2. Push piston in so that pad is firmly installed and mount cylinder body to torque member.

NOTE:

Using a disc brake piston tool (commercial service tool), etc., makes it easier to push in piston.

CAUTION:

By pushing in piston, brake fluid returns to master cylinder reservoir tank. Watch the level of the surface of reservoir tank.

3. Attach pad retainer to torque member.

CAUTION:

When attaching pad retainer, attach it firmly so that it does not float up higher than torque member, as shown in the figure.

4. Install lower sliding pin bolt and tighten it to the specified torque.
5. Check brake for drag.
6. Attach tires to the vehicle.

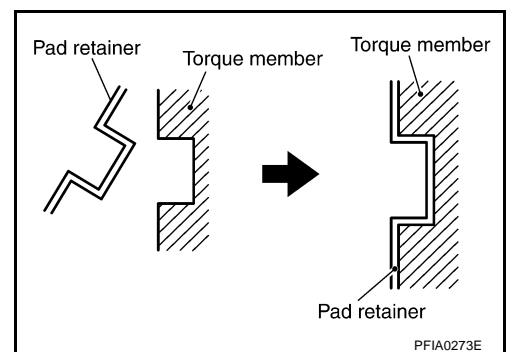

Removal and Installation of Brake Caliper Assembly

AFS001S0

REMOVAL

1. Remove tires from vehicle with power tool.
2. Drain brake fluid. Refer to [BR-9, "Drain and Refill"](#) .
3. Remove union bolts and torque member bolts, and remove brake caliper assembly from the vehicle.
4. Remove disc rotor.

INSTALLATION

CAUTION:

- Refill with new brake fluid "DOT3".

FRONT DISC BRAKE

- **Do not reuse drained brake fluid.**

1. Install disc rotor.
2. Install caliper assembly to the vehicle, and tighten bolts to the specified torque.

CAUTION:

When attaching caliper assembly to the vehicle, wipe any oil off knuckle spindle, washers and caliper assembly attachment surfaces.

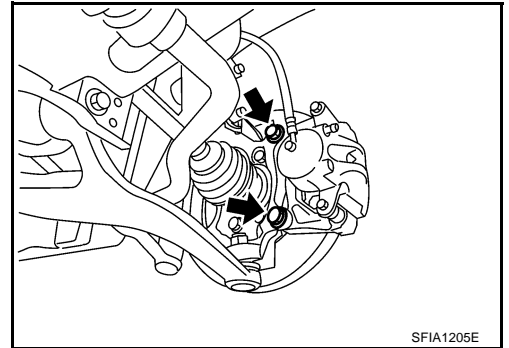

3. Install brake hose to brake caliper assembly, and tighten union bolt to the specified torque.

CAUTION:

- **Do not reuse copper washers for union bolt.**
- **Attach brake hose to caliper assembly together with union bolt and washers.**

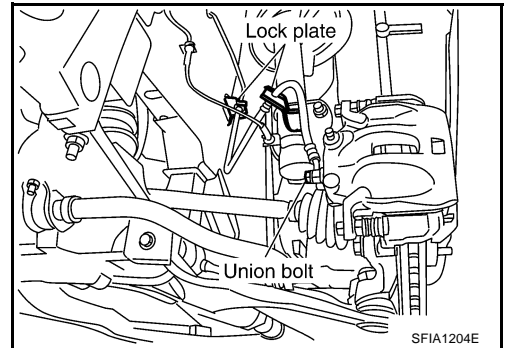

4. Refill new brake fluid and bleed air. Refer to [BR-10, "Bleeding Brake System"](#).
5. Attach tires to the vehicle.

Disassembly and Assembly of Brake Caliper Assembly

AFS001S1

DISASSEMBLY

1. Remove sliding pin bolt, and then remove the pad, shim, shim cover, and pad retainer from the torque member.
2. Remove sliding pins and sliding pin boots from torque member.
3. Place a wooden block as shown in the figure, and blow air from union bolt mounting hole to remove pistons and piston boots.

CAUTION:

Do not get your fingers caught in piston.

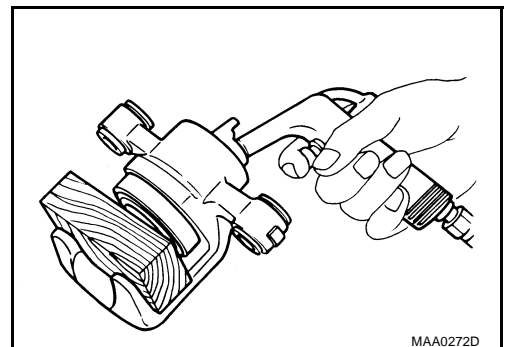

FRONT DISC BRAKE

- Using a flat-bladed screwdriver, remove piston seal from cylinder body.

CAUTION:

Be careful not to damage cylinder inner wall.

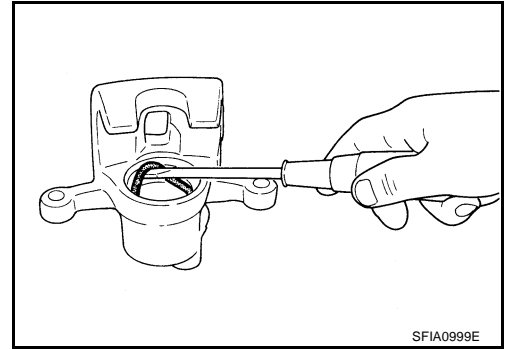

A
B
C
D

CALIPER INSPECTION

Cylinder Body

CAUTION:

- Use new brake fluid for cleaning. Do not use mineral oils such as gasoline or kerosene.
- Check inside surface of cylinder for score, rust, wear, damage or foreign materials. If any of the above conditions are observed, replace cylinder body.
- Minor damage from rust or foreign materials may be eliminated by polishing surface with a fine emery paper. Replace cylinder body if necessary.

BR

Torque Member

Check for wear, cracks, and damage. If damage or deformation is present, replace the affected part.

Piston

Check piston for score, rust, wear, damage or presence of foreign materials. Replace if any of the above condition are observed.

CAUTION:

Piston sliding surface is plated, do not polish with emery paper even if rust or foreign materials are stuck to sliding surface.

Sliding Pins and Sliding Pin Boots

Check sliding pin and sliding pin boot for wear, damage, and cracks. If damage or deformation is present, replace the affected part.

ASSEMBLY

CAUTION:

When assembling, use only rubber lubricant specified below.

- Apply polyglycol ether based lubricant to the piston seal, and install them to the cylinder body.

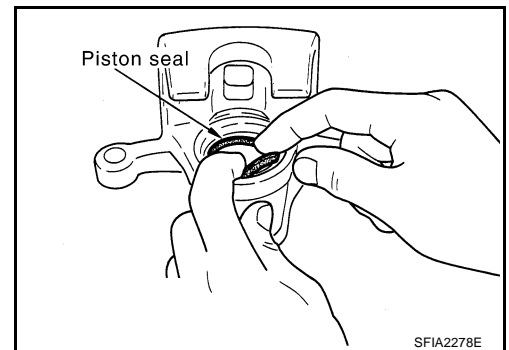

E
G
H
I
J
K
L
M

FRONT DISC BRAKE

2. Apply brake fluid to piston, rubber grease to piston boot, then install piston boot in to piston groove.

CAUTION:

Do not reuse piston boot.

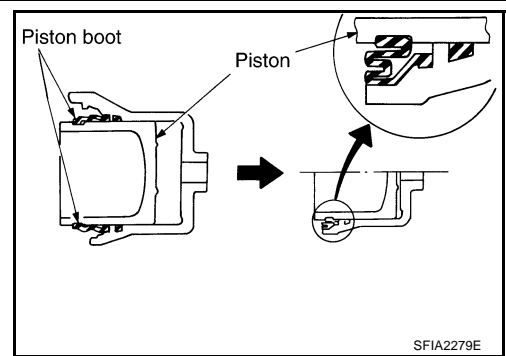

3. Insert into cylinder body by hand and insert piston boot piston-side lip into piston groove.

CAUTION:

Press piston evenly and vary the pressing point to prevent cylinder inner wall from being rubbed.

4. Install sliding pins and sliding pin boots to torque member.
5. Attach inner shim and inner shim cover to inner pad, and attach the outer shim to the outer pad.
6. Install cylinder body. Tighten sliding pin bolt to the specified torque.

DISC ROTOR INSPECTION

Visual Inspection

Check surface of disc rotor for uneven wear, cracks, and serious damage. If any of them is detected, replace applicable part.

Runout Inspection

1. Using wheel nuts, fix disc rotor to wheel hub. (2 or more positions)
2. Inspect runout using a dial gauge. [Measured at 10 mm (0.39 in) inside the disc edge.]

Runout limit (with the disc rotor attached to the vehicle) : 0.04 mm (0.0016 in)

Runout limit (just the disc rotor) : 0.02 mm (0.0008 in)

NOTE:

Make sure that wheel bearing axial end play is within the specifications before measuring runout. Refer to [FAX-4, "On-Vehicle Inspection and Service"](#).

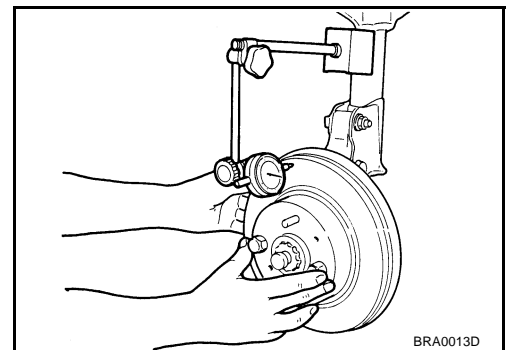

3. If runout is outside the limit, find the minimum runout point by shifting mounting positions of disc rotor and wheel hub by one hole.
4. If runout is still out of specification, turn rotor with on-car brake lathe. ("MAD DL-8700", "AMMCO 700 and 705" or equivalent.)

Thickness Inspection

Using a micrometer, check thickness of disc rotor. If thickness is outside the standard, replace disc rotor.

Standard thickness : 28.0 mm (1.102 in)

Repair limit thickness : 26.0 mm (1.024 in)

Maximum uneven wear : 0.015 mm (0.0006 in) (measured at 8 positions)

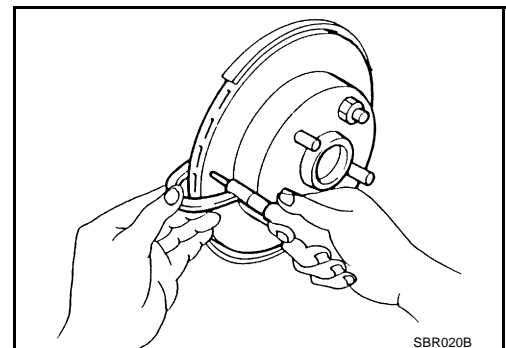

FRONT DISC BRAKE

BRAKE BURNISHING PROCEDURE

Burnish brake contact surface according to the following procedure after refinishing or replacing rotors, after replacing pads, or if a soft pedal occurs at very low mileage.

CAUTION:

Only perform this procedure under safe road and traffic conditions. Use extreme caution.

1. Drive the vehicle on a straight smooth road at 50 km/h (31 MPH).
2. Use medium brake pedal /foot effort to bring the vehicle to a complete stop from 50 km/h (31 MPH). Adjust brake pedal /foot pressure such that vehicle stopping time equals 3 to 5 seconds.
3. To cool brake system, drive the vehicle at 50 km/h (31 MPH) for 1 minute without stopping.
4. Repeat steps 1 to 3, 10 times or more to complete the burnishing procedure.

A

B

C

D

E

BR

G

H

I

J

K

L

M

REAR DISC BRAKE

REAR DISC BRAKE

PFP:44000

On-Vehicle Inspection PAD WEAR INSPECTION

AFS001NA

- Inspect the thickness of pad through cylinder body inspection hole. Use a scale for inspection if necessary.

Standard thickness : 8.5 mm (0.335 in)

Repair limit thickness : 2.0 mm (0.079 in)

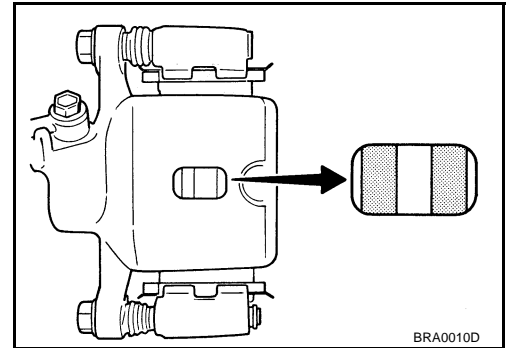

Components



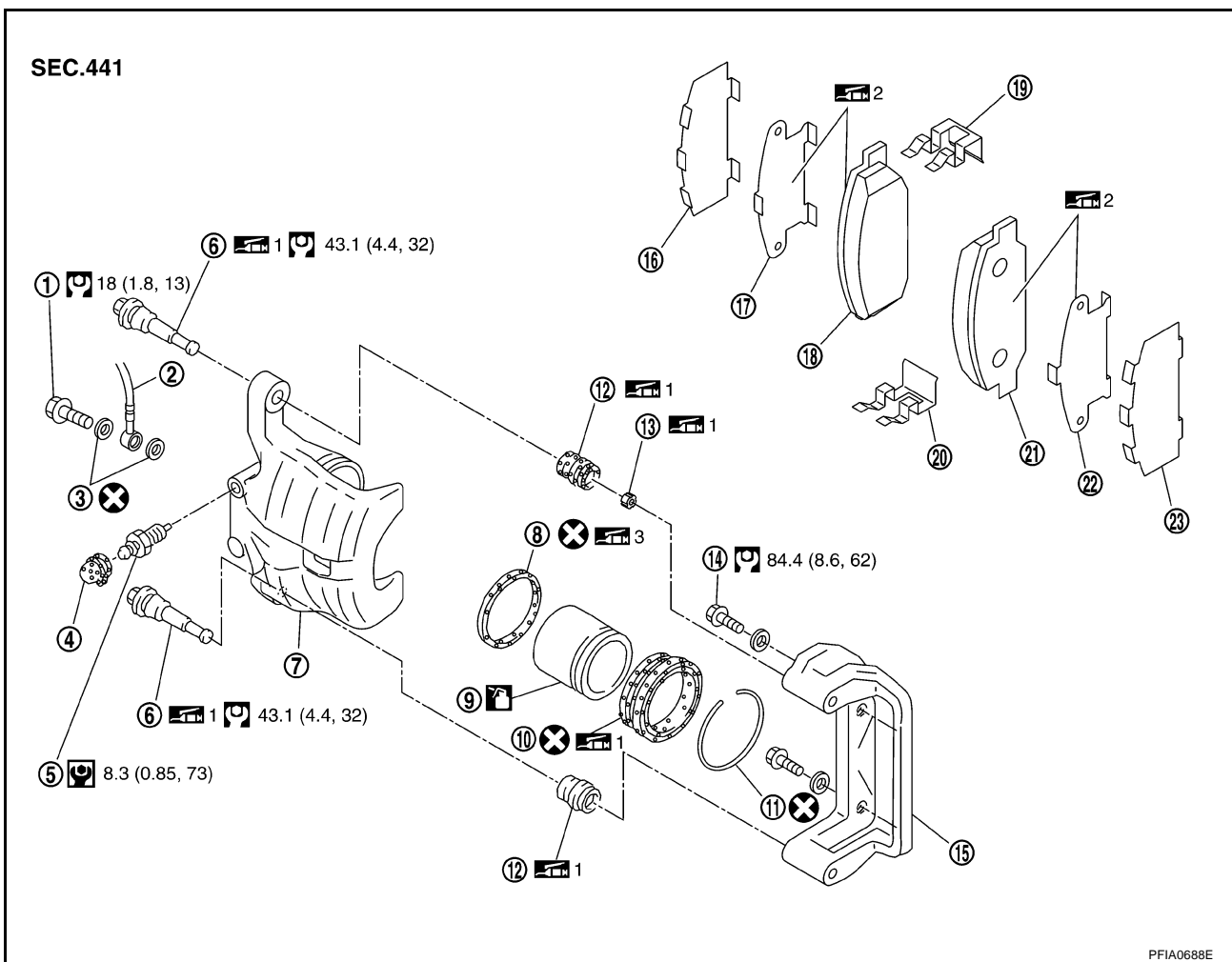

AFS001NB



- | | | |
|--------------------------|--------------------------|----------------------|
| 1. Union bolt | 2. Brake hose | 3. Copper washer |
| 4. Cap | 5. Bleed valve | 6. Sliding pin bolt |
| 7. Cylinder body | 8. Piston seal | 9. Piston |
| 10. Piston boot | 11. Retaining ring | 12. Sliding pin boot |
| 13. Bushing | 14. Torque member bolt | 15. Torque member |
| 16. Inner shim cover | 17. Inner shim | 18. Inner pad |
| 19. Pad retainer (Upper) | 20. Pad retainer (Lower) | 21. Outer pad |
| 22. Outer shim | 23. Outer shim cover | |

Refer to [GI-10. "Components"](#) and the followings for the symbols in the figure.

REAR DISC BRAKE

-  1: Rubber grease
-  2: PBC (Poly Butyl Cuprysil) grease or silicone-based grease
-  3: Polyglycol ether based lubricant
-  : Brake fluid

WARNING:

Clean dust on caliper and brake pad with a vacuum dust collector to minimize the hazard of airborne particles or other materials.

CAUTION:

- While removing cylinder body, never depress brake pedal because piston will pop out.
- It is not necessary to remove bolts on torque member and brake hose except for disassembly or replacement of caliper assembly. In this case, hang cylinder body with a wire so as not to stretch brake hose.
- Do not damage piston boot.
- If any shim is subject to serious corrosion, replace it with a new one.
- Always replace shims and shim covers as a set when replacing brake pads.
- Burnish brake contact surface after refinishing or replacing rotors, after replacing pads, or if a soft pedal occurs at very low mileage. Refer to [BR-31, "BRAKE BURNISHING PROCEDURE"](#)

Removal and Installation of Brake Pad

AFS001NC

REMOVAL

1. Remove tires from vehicle with power tool.
2. Remove sliding pin bolt (one on top).
3. Suspend cylinder body with a wire, and remove pads, pad retainers, shim from torque member.

INSTALLATION

1. Apply PBC (Poly Butyl Cuprysil) grease or silicon-based grease to the backside of pad and to both sides of shim, and attach inner shim and shim cover to inner pad, and attach the outer shim and outer shim cover to outer pad.
2. Install pad retainer and mount pad to torque member.
3. Push piston in so that pad is firmly attached and mount cylinder body to torque member.

NOTE:

Using a disc brake piston tool (commercial service tool), etc., makes it easier to push in piston.

CAUTION:

By pushing in piston, brake fluid returns to master cylinder reservoir tank. Watch the level of the surface of reservoir tank.

4. Install sliding pin bolt (one on top) and tighten to the specified torque.
5. Check brake for drag.
6. Install tires to the vehicle.

Removal and Installation of Brake Caliper Assembly

AFS001ND

REMOVAL

1. Remove tires from vehicle with power tool.
2. Drain brake fluid. Refer to [BR-9, "Drain and Refill"](#).
3. Remove union bolt and torque member bolts, and remove brake caliper assembly from the vehicle.
4. Remove disc rotor.

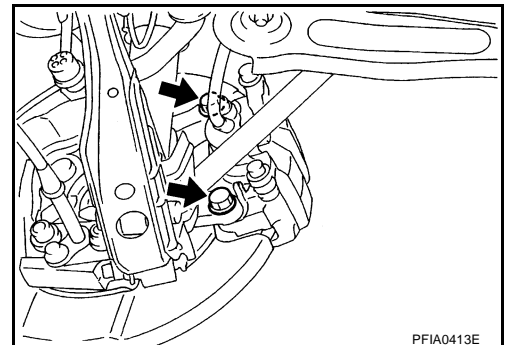

REAR DISC BRAKE

INSTALLATION

CAUTION:

- Refill with new brake fluid "DOT 3".
- Do not reuse drained brake fluid.

1. Install disc rotor.
2. Install caliper assembly to the vehicle, and tighten bolts to the specified torque.

CAUTION:

Before installing caliper assembly to the vehicle, wipe off oil and grease on washer seats on axle assembly and mounting surface of caliper assembly.

3. Install brake hose to caliper assembly and tighten union bolt to the specified torque.

CAUTION:

- Do not reuse copper washer for union bolt.
 - Securely attach brake hose to protrusion on caliper assembly.
4. Refill new brake fluid and bleed air. Refer to [BR-10, "Bleeding Brake System"](#).
 5. Install tires to the vehicle.

Disassembly and Assembly of Brake Caliper Assembly

AFS001NE

DISASSEMBLY

1. Remove sliding pin bolt, and then remove pad, shim, shim cover, and pad retainer from torque member and cylinder.
2. Remove sliding pin boot from torque member.
3. As shown in the figure, using a flat-bladed screwdriver, remove retaining ring from cylinder body.

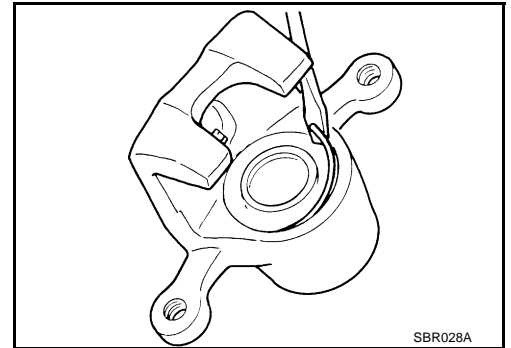

4. Place a wooden block as shown in the figure, and blow air from union bolt mounting hole to remove pistons and piston boots.

CAUTION:

Do not get your fingers caught in piston.

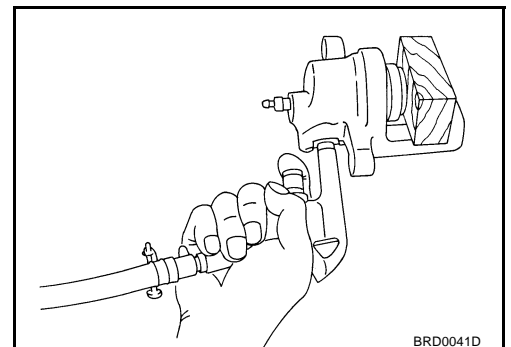

5. Using a flat-bladed screwdriver, remove piston seals from cylinder body.

CAUTION:

Be careful not to damage cylinder inner wall.

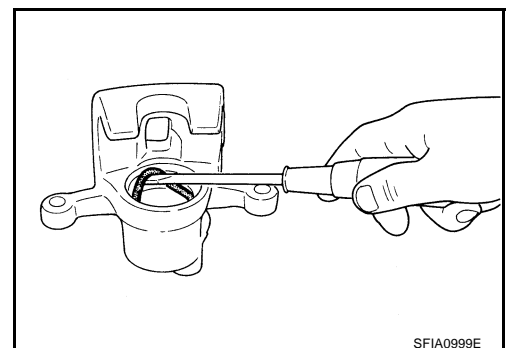

REAR DISC BRAKE

CALIPER INSPECTION

Cylinder Body

CAUTION:

- Use new brake fluid to clean. Do not use mineral oils such as gasoline or kerosene.
- Check inside surface of cylinder for score, rust wear, damage or foreign materials. If any of the above conditions are observed, replace cylinder body.
- Minor damage from rust or foreign materials may be eliminated by polishing surface with a fine emery paper. Replace cylinder body if necessary.

Torque Member

Check for wear, cracks, and damage. If damage or deformation is present, replace the affected part.

Piston

CAUTION:

- Piston sliding surface is plated, do not polish with emery paper even if rust or foreign materials are stuck to sliding surface.
- Check piston for score, rust, wear, damage or presence of foreign materials. Replace if any of the above condition are observed.

Sliding Pin Bolts and Sliding Pin Boots

Make sure there is no wear, damage, or cracks in sliding pin bolts and sliding pin boots, and if there are, replace them.

ASSEMBLY

CAUTION:

When assembling, use only rubber lubricant specified below.

1. Apply polyglycol ether based lubricant to the piston seal, and install them to the cylinder body.

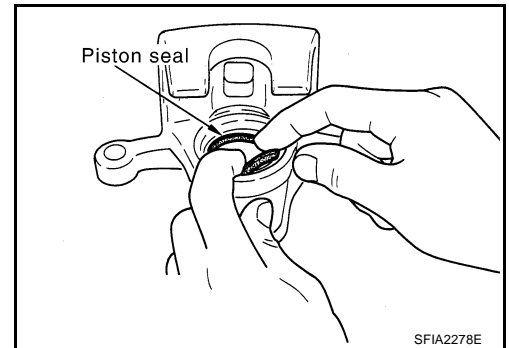

2. Apply brake fluid to piston rubber grease to piston boot, then install piston boot in to piston groove.

CAUTION:

Do not reuse piston boot.

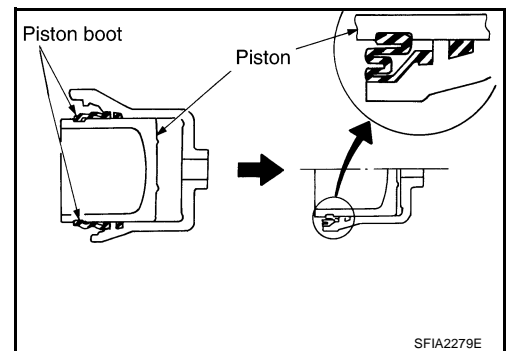

3. Insert into cylinder body by hand and insert piston boot piston-side lip into piston groove.

CAUTION:

Press piston evenly and vary the pressing point to prevent cylinder inner wall from being rubbed.

REAR DISC BRAKE

- Fix piston boot with retaining ring.

CAUTION:

- Make sure boot is firmly in cylinder body groove.
- Do not reuse retaining ring.

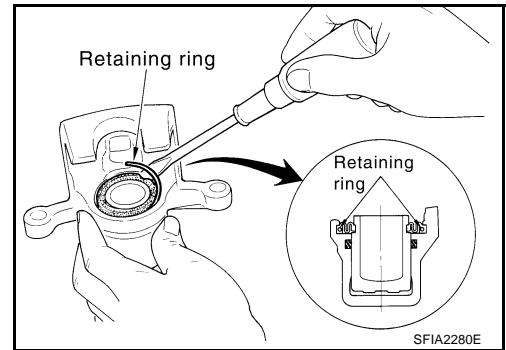

- Install sliding pin bolt and sliding pin boots to torque member.
- Apply PBC (Poly Butyl Cuprysil) grease or silicon-based grease to the backside of pad and to both sides of shim, and attach inner shim and shim cover to inner pad, and the outer shim and outer shim cover to outer pad.
- Assembling shims and shim covers to pad.

CAUTION:

When attaching pad retainer, attach it firmly so that it does not float up higher than torque member, as shown in the figure.

- Attach pad retainer and pad to torque member.
- Install cylinder body. Tighten sliding pin bolts to the specified torque.

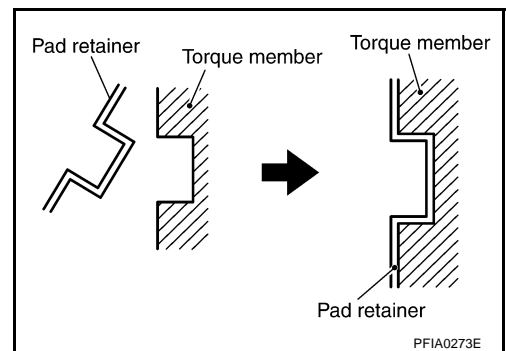

DISC ROTOR INSPECTION

Visual Inspection

Check surface of disc rotor for uneven wear, cracks, and serious damage. If any non-standard condition is detected, replace applicable part.

Runout Inspection

- Using wheel nuts, fix disc rotor to wheel hub. (2 or more positions)
- Inspect runout using a dial gauge. [Measured at 10 mm (0.39 in) inside disk edge.]

Runout limit (with it attached to the vehicle) : 0.05 mm (0.0020 in)

NOTE:

Make sure that wheel bearing axial end play is within the specification before measuring runout. Refer to [RAX-5, "On-Vehicle Inspection and Service"](#).

- If runout is outside the limit, find the minimum runout point by shifting mounting positions of disc rotor and wheel hub by one hole.
- If runout still out of specification, turn rotor with on-car brake lathe ("MAD, DL-8700", "AMMCO 700 and 705" or equivalent).

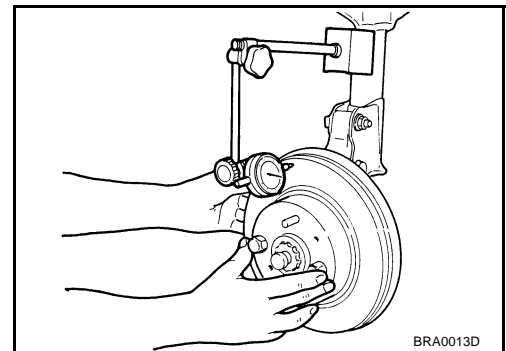

REAR DISC BRAKE

Thickness Inspection

Using a micrometer, check thickness of disc rotor. If thickness is outside the standard, replace disc rotor.

Standard thickness	: 16.0 mm (0.630 in)
Wear limit	: 14.0 mm (0.551 in)
Maximum uneven wear (measured at 8 positions)	: 0.015 mm (0.0006 in)

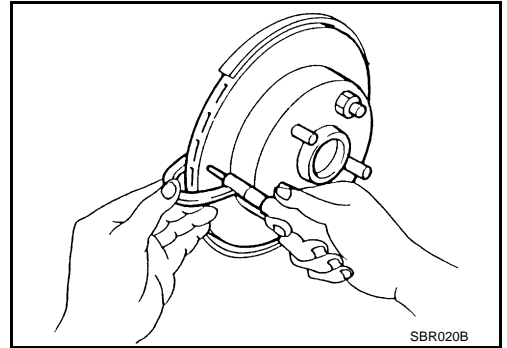

BRAKE BURNISHING PROCEDURE

Burnish brake contact surface according to the following procedure after refinishing or replacing rotors, after replacing pads, or if a soft pedal occurs at very low mileage.

CAUTION:

Only perform this procedure under safe road and traffic conditions. Use extreme caution.

1. Drive the vehicle on a straight smooth road at 50 km/h (31 MPH).
2. Use medium brake pedal /foot effort to bring the vehicle to a complete stop from 50 km/h (31 MPH). Adjust brake pedal /foot pressure such that vehicle stopping time equals 3 to 5 seconds.
3. To cool brake system, drive the vehicle at 50 km/h (31 MPH) for 1 minute without stopping.
4. Repeat steps 1 to 3, 10 times or more to complete the burnishing procedure.

SERVICE DATA AND SPECIFICATIONS (SDS)

SERVICE DATA AND SPECIFICATIONS (SDS)

PFP:00030

General Specifications

AFS001NF

Unit: mm (in)

Front brake	Rotor outer diameter × thickness		320 × 28 (12.60 × 1.10)
	Pad length × width × thickness		111.0 × 73.5 × 9.5 (4.73 × 2.894 × 0.374)
	Cylinder bore diameter		63.6 (2.504)
Rear brake	Rotor outer diameter × thickness		308 × 16 (12.13 × 0.63)
	Pad length × width × thickness		83.0 × 33.0 × 8.5 (3.268 × 1.299 × 0.335)
	Cylinder bore diameter		42.86 (1.6874)
Master cylinder	Cylinder bore diameter		25.4 (1.00)
Control valve	Valve model		Electric brake force distribution
Brake booster	Diaphragm diameter	Primary	228.5 (9.0)
		Secondary	203.0 (8.0)
Recommended brake fluid			DOT 3

Brake Pedal

AFS001NG

Brake pedal height (from dash panel top surface)	161.5 – 171.5 mm (6.36 – 6.75 in)
Depressed pedal height [under a force of 490 N (50 kg, 110 lb) with engine running]	More than 80 mm (3.15 in)
Clearance between stopper rubber and the threaded end of stop lamp switch	0.74 – 1.96 mm (0.0291 – 0.0772 in)
Pedal play	3 – 11 mm (0.12 – 0.43 in)

Brake Booster Vacuum type

AFS001NH

Input rod installation standard dimension	126.5 mm (4.98 in)
---	--------------------

Check Valve

AFS001NI

Vacuum leakage [at a vacuum of -66.7 kPa (-500 mmHg, -19.69 inHg)]	Within a vacuum of 1.3 kPa (10 mmHg, 0.39 inHg) for 15 seconds
---	--

Front Disc Brake

AFS001NJ

Brake pad	Standard thickness (new)	9.5 mm (0.374 in)
	Repair limit thickness	2.0 mm (0.079 in)
Disc rotor	Standard thickness (new)	28.0 mm (1.102 in)
	Repair limit thickness	26.0 mm (1.024 in)
	Maximum uneven wear (measured at 8 positions)	0.015mm (0.0006 in)
	Runout limit (with the disc rotor attached to the vehicle)	0.04 mm (0.0016 in)

Rear Disc Brake

AFS001NK

Brake pad	Standard thickness (new)	8.5 mm (0.335 in)
	Repair limit thickness	2.0 mm (0.079 in)
Disc rotor	Standard thickness (new)	16.0 mm (0.630 in)
	Repair limit thickness	14.0 mm (0.551 in)
	Maximum uneven wear (measured at 8 positions)	0.015 mm (0.0006 in)
	Runout limit (with the disc rotor attached to the vehicle)	0.05 mm (0.0020 in)