

SECTION **RF**
ROOF

A
B
C
D
E
F
G
H
RF
J
K
L
M

CONTENTS

PRECAUTIONS	2	ANTI-PINCH FUNCTION	12
Precautions for Supplemental Restraint System (SRS) "AIR BAG" and "SEAT BELT PRE-TENSIONER"	2	MEMORY RESET PROCEDURE	12
Precautions	2	INITIALIZATION PROCEDURE	12
PREPARATION	3	CAN Communication System Description	13
Special Service Tools	3	CAN Communication Unit	13
Commercial Service Tools	3	Wiring Diagram — SROOF —	14
SQUEAK AND RATTLE TROUBLE DIAGNOSES	4	Terminals and Reference Value for BCM	15
Work Flow	4	Terminals and Reference Value for Sunroof Motor Assembly	15
CUSTOMER INTERVIEW	4	Work Flow	16
DUPLICATE THE NOISE AND TEST DRIVE	5	CONSULT-II Inspection Procedure	16
CHECK RELATED SERVICE BULLETINS	5	ACTIVE TEST	17
LOCATE THE NOISE AND IDENTIFY THE ROOT CAUSE	5	WORK SUPPORT	17
REPAIR THE CAUSE	5	DATE MONITOR	17
CONFIRM THE REPAIR	6	Trouble Diagnosis Chart by Symptom	18
Generic Squeak and Rattle Troubleshooting	6	Power Supply and Ground Circuit Check of BCM..	18
INSTRUMENT PANEL	6	SunroofMotorAssemblyPowerSupplyandGround Circuit Check	19
CENTER CONSOLE	6	Sunroof Switch System Check	20
DOORS	6	Door Switch Check	22
TRUNK	7	Wind Deflector Inspection	24
SUNROOF/HEADLINING	7	Link and Wire Assembly	24
SEATS	7	Fitting Adjustment	24
UNDERHOOD	7	LID WEATHERSTRIP OVERLAP ADJUSTMENT AND SURFACE MISMATCH ADJUSTMENT	25
Diagnostic Worksheet	8	Removal and Installation	25
SUNROOF	10	SUNROOF UNIT ASSEMBLY	27
Component Parts and Harness Connector Location..	10	GLASS LID	28
System Description	11	SUNSHADE	29
TILT UP / SLIDE CLOSE OPERATION	11	WIND DEFLECTOR	29
TILT DOWN / SLIDE OPEN OPERATION	11	SUNROOF MOTOR ASSEMBLY	29
AUTO OPERATION	11		
RETAINED POWER OPERATION	11		

PRECAUTIONS

PRECAUTIONS

PF0:00001

Precautions for Supplemental Restraint System (SRS) “AIR BAG” and “SEAT BELT PRE-TENSIONER”

AIS003AR

The Supplemental Restraint System such as “AIR BAG” and “SEAT BELT PRE-TENSIONER”, used along with a front seat belt, helps to reduce the risk or severity of injury to the driver and front passenger for certain types of collision. This system includes seat belt switch inputs and dual stage front air bag modules. The SRS system uses the seat belt switches to determine the front air bag deployment, and may only deploy one front air bag, depending on the severity of a collision and whether the front occupants are belted or unbelted. Information necessary to service the system safely is included in the SRS and SB section of this Service Manual.

WARNING:

- To avoid rendering the SRS inoperative, which could increase the risk of personal injury or death in the event of a collision which would result in air bag inflation, all maintenance must be performed by an authorized NISSAN/INFINITI dealer.
- Improper maintenance, including incorrect removal and installation of the SRS, can lead to personal injury caused by unintentional activation of the system. For removal of Spiral Cable and Air Bag Module, see the SRS section.
- Do not use electrical test equipment on any circuit related to the SRS unless instructed to in this Service Manual. SRS wiring harnesses can be identified by yellow and/or orange harnesses or harness connectors.

Precautions

AIS003AS

- Disconnect both battery cables in advance.
- Do not tamper with or force air bag lid open, as this may adversely affect air bag performance.
- Be careful not to scratch pad and other parts.
- When removing or disassembling any part, be careful not to damage or deform it. Protect parts, which may get in the way with cloth.
- When removing parts with a screwdriver or other tool, protect parts by wrapping them with vinyl or tape.
- Keep removed parts protected with cloth.
- If a clip is deformed or damaged, replace it.
- If an un reusable part is removed, replace it with a new one.
- Tighten bolts and nuts firmly to the specified torque.
- After re-assembly has been completed, make sure each part functions correctly.
- Remove stains in the following way.

Water-soluble stains:

Dip a soft cloth in warm water, and then squeeze it tightly. After wiping the stain, wipe with a soft dry cloth.

Oil stain:

Dissolve a synthetic detergent in warm water (density of 2 to 3% or less), dip the cloth, then clean off the stain with the cloth. Next, dip the cloth in fresh water and squeeze it tightly. Then clean off the detergent completely. Then wipe the area with a soft dry cloth.

- Do not use any organic solvent, such as thinner or benzene.

PREPARATION

PREPARATION

PFP:00002

Special Service Tools

AIS003AT

The actual shapes of Kent-Moore tools may differ from those of special service tools illustrated here.

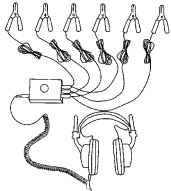
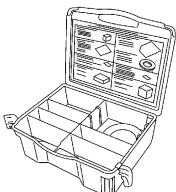
Tool number (Kent-Moore No.) Tool name	Description
(J39570) Chassis ear  <p style="text-align: right; margin-right: 20px;">SIIA0993E</p>	Locating the noise
(J43980) NISSAN Squeak and Rattle Kit  <p style="text-align: right; margin-right: 20px;">SIIA0994E</p>	Repairing the cause of noise

Commercial Service Tools

AIS003AU

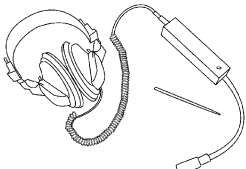
Tool name	Description
(J39565) Engine ear  <p style="text-align: right; margin-right: 20px;">SIIA0995E</p>	Locating the noise

A
B
C
D
E
F
G
H
RF
J
K
L
M

RF

SQUEAK AND RATTLE TROUBLE DIAGNOSES

SQUEAK AND RATTLE TROUBLE DIAGNOSES

PFP:00000

Work Flow

AIS003AV

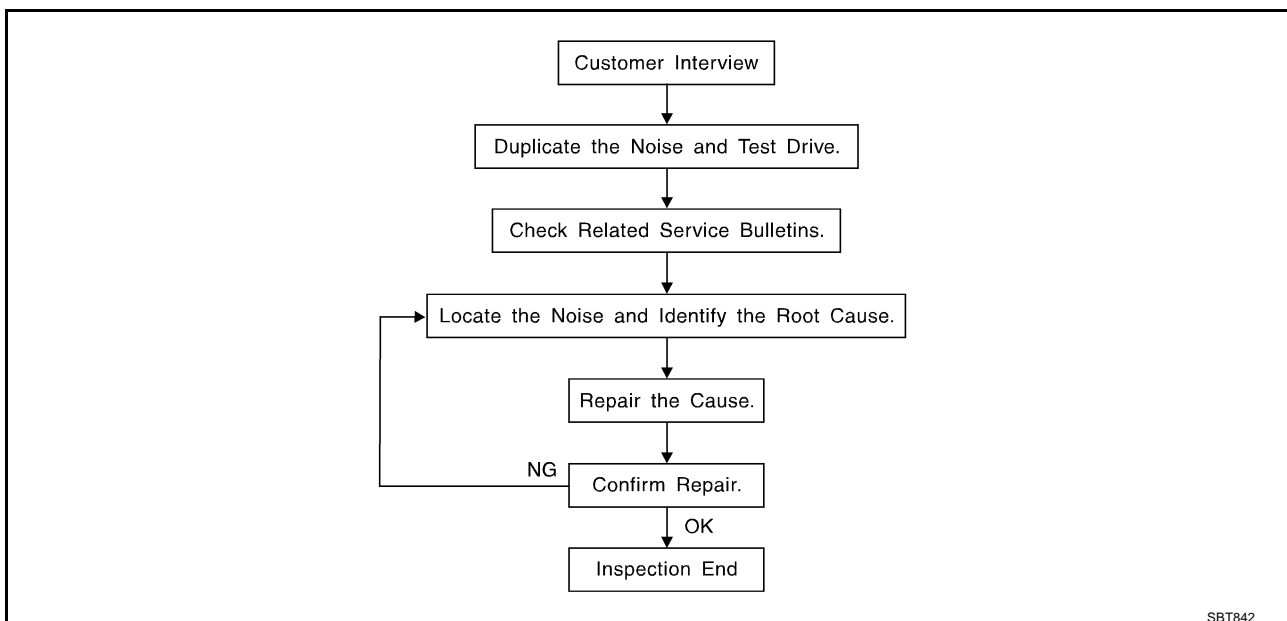

CUSTOMER INTERVIEW

Interview the customer if possible, to determine the conditions that exist when the noise occurs. Use the Diagnostic Worksheet during the interview to document the facts and conditions when the noise occurs and any customer's comments; refer to [RF-8, "Diagnostic Worksheet"](#). This information is necessary to duplicate the conditions that exist when the noise occurs.

- The customer may not be able to provide a detailed description or the location of the noise. Attempt to obtain all the facts and conditions that exist when the noise occurs (or does not occur).
- If there is more than one noise in the vehicle, be sure to diagnose and repair the noise that the customer is concerned about. This can be accomplished by test driving the vehicle with the customer.
- After identifying the type of noise, isolate the noise in terms of its characteristics. The noise characteristics are provided so the customer, service adviser and technician are all speaking the same language when defining the noise.
- Squeak —(Like tennis shoes on a clean floor)
Squeak characteristics include the light contact/fast movement/brought on by road conditions/hard surfaces=higher pitch noise/softer surfaces=lower pitch noises/edge to surface=chirping
- Creak—(Like walking on an old wooden floor)
Creak characteristics include firm contact/slow movement/twisting with a rotational movement/pitch dependent on materials/often brought on by activity.
- Rattle—(Like shaking a baby rattle)
Rattle characteristics include the fast repeated contact/vibration or similar movement/loose parts/missing clip or fastener/incorrect clearance.
- Knock —(Like a knock on a door)
Knock characteristics include hollow sounding/sometimes repeating/often brought on by driver action.
- Tick—(Like a clock second hand)
Tick characteristics include gentle contacting of light materials/loose components/can be caused by driver action or road conditions.
- Thump—(Heavy, muffled knock noise)
Thump characteristics include softer knock/dead sound often brought on by activity.
- Buzz—(Like a bumble bee)
Buzz characteristics include high frequency rattle/firm contact.
- Often the degree of acceptable noise level will vary depending upon the person. A noise that you may judge as acceptable may be very irritating to the customer.
- Weather conditions, especially humidity and temperature, may have a great effect on noise level.

SQUEAK AND RATTLE TROUBLE DIAGNOSES

DUPLICATE THE NOISE AND TEST DRIVE

If possible, drive the vehicle with the customer until the noise is duplicated. Note any additional information on the Diagnostic Worksheet regarding the conditions or location of the noise. This information can be used to duplicate the same conditions when you confirm the repair.

If the noise can be duplicated easily during the test drive, to help identify the source of the noise, try to duplicate the noise with the vehicle stopped by doing one or all of the following:

- 1) Close a door.
 - 2) Tap or push/pull around the area where the noise appears to be coming from.
 - 3) Rev the engine.
 - 4) Use a floor jack to recreate vehicle "twist".
 - 5) At idle, apply engine load (electrical load, half-clutch on M/T model, drive position on A/T model).
 - 6) Raise the vehicle on a hoist and hit a tire with a rubber hammer.
- Drive the vehicle and attempt to duplicate the conditions the customer states exist when the noise occurs.
 - If it is difficult to duplicate the noise, drive the vehicle slowly on an undulating or rough road to stress the vehicle body.

CHECK RELATED SERVICE BULLETINS

After verifying the customer concern or symptom, check ASIST for Technical Service Bulletins (TSBs) related to that concern or symptom.

If a TSB relates to the symptom, follow the procedure to repair the noise.

LOCATE THE NOISE AND IDENTIFY THE ROOT CAUSE

1. Narrow down the noise to a general area. To help pinpoint the source of the noise, use a listening tool (Chassis Ear: J39570, Engine Ear and mechanics stethoscope).
2. Narrow down the noise to a more specific area and identify the cause of the noise by:
 - removing the components in the area that you suspect the noise is coming from.
Do not use too much force when removing clips and fasteners, otherwise clips and fastener can be broken or lost during the repair, resulting in the creation of new noise.
 - tapping or pushing/pulling the component that you suspect is causing the noise.
Do not tap or push/pull the component with excessive force, otherwise the noise will be eliminated only temporarily.
 - feeling for a vibration with your hand by touching the component(s) that you suspect is (are) causing the noise.
 - placing a piece of paper between components that you suspect are causing the noise.
 - looking for loose components and contact marks.
Refer to [RF-6, "Generic Squeak and Rattle Troubleshooting"](#).

REPAIR THE CAUSE

- If the cause is a loose component, tighten the component securely.
- If the cause is insufficient clearance between components:
 - separate components by repositioning or loosening and retightening the component, if possible.
 - insulate components with a suitable insulator such as urethane pads, foam blocks, felt cloth tape or urethane tape. A Nissan Squeak and Rattle Kit (J43980) is available through your authorized Nissan Parts Department.

CAUTION:

Do not use excessive force as many components are constructed of plastic and may be damaged.

Always check with the Parts Department for the latest parts information.

The following materials are contained in the Nissan Squeak and Rattle Kit (J43980). Each item can be ordered separately as needed.

URETHANE PADS [1.5 mm (0.059 in) thick]

Insulates connectors, harness, etc.

76268-9E005: 100 × 135 mm (3.94 × 5.31 in)/76884-71L01: 60 × 85 mm (2.36 × 3.35 in)/76884-71L02: 15 × 25 mm (0.59 × 0.98 in)

INSULATOR (Foam blocks)

Insulates components from contact. Can be used to fill space behind a panel.

73982-9E000: 45 mm (1.77 in) thick, 50 × 50 mm (1.97 × 1.97 in)/73982-50Y00: 10 mm (0.39 in) thick, 50 × 50 mm (1.97 × 1.97 in)

SQUEAK AND RATTLE TROUBLE DIAGNOSES

INSULATOR (Light foam block)

80845-71L00: 30 mm (1.18 in) thick, 30 × 50 mm (1.18 × 1.97 in)

FELT CLOTHTAPE

Used to insulate where movement does not occur. Ideal for instrument panel applications.

68370-4B000: 15 × 25 mm (0.59 × 0.98 in) pad/68239-13E00: 5 mm (0.20 in) wide tape roll

The following materials, not found in the kit, can also be used to repair squeaks and rattles.

UHMW(TEFLON) TAPE

Insulates where slight movement is present. Ideal for instrument panel applications.

SILICONE GREASE

Used in place of UHMW tape that will be visible or not fit.

Note: Will only last a few months.

SILICONE SPRAY

Use when grease cannot be applied.

DUCT TAPE

Use to eliminate movement.

CONFIRM THE REPAIR

Confirm that the cause of a noise is repaired by test driving the vehicle. Operate the vehicle under the same conditions as when the noise originally occurred. Refer to the notes on the Diagnostic Worksheet.

Generic Squeak and Rattle Troubleshooting

AIS003AW

Refer to Table of Contents for specific component removal and installation information.

INSTRUMENT PANEL

Most incidents are caused by contact and movement between:

1. Cluster lid A and instrument panel
2. Acrylic lens and combination meter housing
3. Instrument panel to front pillar garnish
4. Instrument panel to windshield
5. Instrument panel mounting pins
6. Wiring harnesses behind the combination meter
7. A/C defroster duct and duct joint

These incidents can usually be located by tapping or moving the components to duplicate the noise or by pressing on the components while driving to stop the noise. Most of these incidents can be repaired by applying felt cloth tape or silicon spray (in hard to reach areas). Urethane pads can be used to insulate wiring harness.

CAUTION:

Do not use silicone spray to isolate a squeak or rattle. If you saturate the area with silicone, you will not be able to recheck the repair.

CENTER CONSOLE

Components to pay attention to include:

1. Shifter assembly cover to finisher
2. A/C control unit and cluster lid C
3. Wiring harnesses behind audio and A/C control unit

The instrument panel repair and isolation procedures also apply to the center console.

DOORS

Pay attention to the:

1. Finisher and inner panel making a slapping noise
2. Inside handle escutcheon to door finisher
3. Wiring harnesses tapping
4. Door striker out of alignment causing a popping noise on starts and stops

Tapping or moving the components or pressing on them while driving to duplicate the conditions can isolate many of these incidents. You can usually insulate the areas with felt cloth tape or insulator foam blocks from the Nissan Squeak and Rattle Kit (J43980) to repair the noise.

SQUEAK AND RATTLE TROUBLE DIAGNOSES

TRUNK

Trunk noises are often caused by a loose jack or loose items put into the trunk by the owner. In addition look for:

1. Trunk lid dumpers out of adjustment
2. Trunk lid striker out of adjustment
3. Trunk lid torsion bars knocking together
4. A loose license plate or bracket

Most of these incidents can be repaired by adjusting, securing or insulating the item(s) or component(s) causing the noise.

SUNROOF/HEADLINING

Noises in the sunroof/headlining area can often be traced to one of the following:

1. Sunroof lid, rail, linkage or seals making a rattle or light knocking noise
2. Sunvisor shaft shaking in the holder
3. Front or rear windshield touching headlining and squeaking

Again, pressing on the components to stop the noise while duplicating the conditions can isolate most of these incidents. Repairs usually consist of insulating with felt cloth tape.

SEATS

When isolating seat noise it's important to note the position the seat is in and the load placed on the seat when the noise is present. These conditions should be duplicated when verifying and isolating the cause of the noise.

Cause of seat noise include:

1. Headrest rods and holder
2. A squeak between the seat pad cushion and frame
3. Rear seatback lock and bracket

These noises can be isolated by moving or pressing on the suspected components while duplicating the conditions under which the noise occurs. Most of these incidents can be repaired by repositioning the component or applying urethane tape to the contact area.

UNDERHOOD

Some interior noise may be caused by components under the hood or on the engine wall. The noise is then transmitted into the passenger compartment.

Causes of transmitted underhood noise include:

1. Any component mounted to the engine wall
2. Components that pass through the engine wall
3. Engine wall mounts and connectors
4. Loose radiator mounting pins
5. Hood bumpers out of adjustment
6. Hood striker out of adjustment

These noises can be difficult to isolate since they cannot be reached from the interior of the vehicle. The best method is to secure, move or insulate one component at a time and test drive the vehicle. Also, engine RPM or load can be changed to isolate the noise. Repairs can usually be made by moving, adjusting, securing, or insulating the component causing the noise.

A

B

C

D

E

F

G

H

RF

J

K

L

M

SQUEAK AND RATTLE TROUBLE DIAGNOSES

Diagnostic Worksheet

AIS003AX



SQUEAK & RATTLE DIAGNOSTIC WORKSHEET

Dear Infiniti Customer:

We are concerned about your satisfaction with your Infiniti vehicle. Repairing a squeak or rattle sometimes can be very difficult. To help us fix your Infiniti right the first time, please take a moment to note the area of the vehicle where the squeak or rattle occurs and under what conditions. You may be asked to take a test drive with a service advisor or technician to ensure we confirm the noise you are hearing.

I. WHERE DOES THE NOISE COME FROM? (circle the area of the vehicle)

The illustrations are for reference only, and may not reflect the actual configuration of your vehicle.

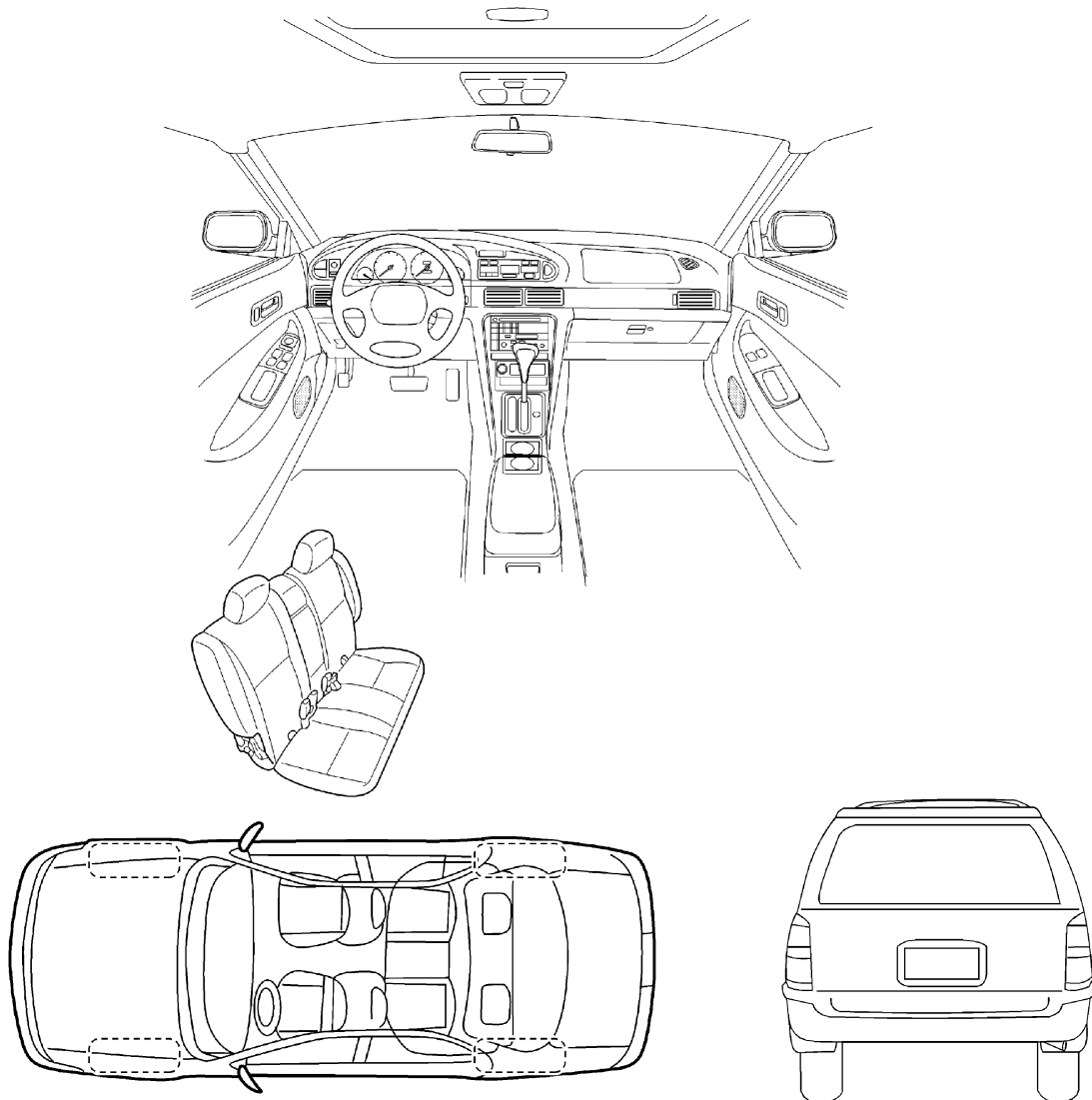

Continue to the back of the worksheet and briefly describe the location of the noise or rattle. In addition, please indicate the conditions which are present when the noise occurs.

SBT860

SQUEAK AND RATTLE TROUBLE DIAGNOSES

SQUEAK & RATTLE DIAGNOSTIC WORKSHEET- page 2

Briefly describe the location where the noise occurs:

II. WHEN DOES IT OCCUR? (check the boxes that apply)

- | | |
|--|---|
| <input type="checkbox"/> anytime | <input type="checkbox"/> after sitting out in the sun |
| <input type="checkbox"/> 1 st time in the morning | <input type="checkbox"/> when it is raining or wet |
| <input type="checkbox"/> only when it is cold outside | <input type="checkbox"/> dry or dusty conditions |
| <input type="checkbox"/> only when it is hot outside | <input type="checkbox"/> other: _____ |

III. WHEN DRIVING:

- through driveways
- over rough roads
- over speed bumps
- only at about ____ mph
- on acceleration
- coming to a stop
- on turns : left, right or either (circle)
- with passengers or cargo
- other: _____
- after driving ____ miles or ____ minutes

IV. WHAT TYPE OF NOISE?

- squeak (like tennis shoes on a clean floor)
- creak (like walking on an old wooden floor)
- rattle (like shaking a baby rattle)
- knock (like a knock on a door)
- tick (like a clock second hand)
- thump (heavy, muffled knock noise)
- buzz (like a bumble bee)

TO BE COMPLETED BY DEALERSHIP PERSONNEL

Test Drive Notes:

	YES	NO	Initials of person performing
Vehicle test driven with customer	<input type="checkbox"/>	<input type="checkbox"/>	_____
- Noise verified on test drive	<input type="checkbox"/>	<input type="checkbox"/>	_____
- Noise source located and repaired	<input type="checkbox"/>	<input type="checkbox"/>	_____
- Follow up test drive performed to confirm repair	<input type="checkbox"/>	<input type="checkbox"/>	_____

VIN: _____ Customer Name: _____

W.O. #: _____ Date: _____

This form must be attached to Work Order

SBT844

SUNROOF

PFP:91210

AIS003CR

SUNROOF

Component Parts and Harness Connector Location

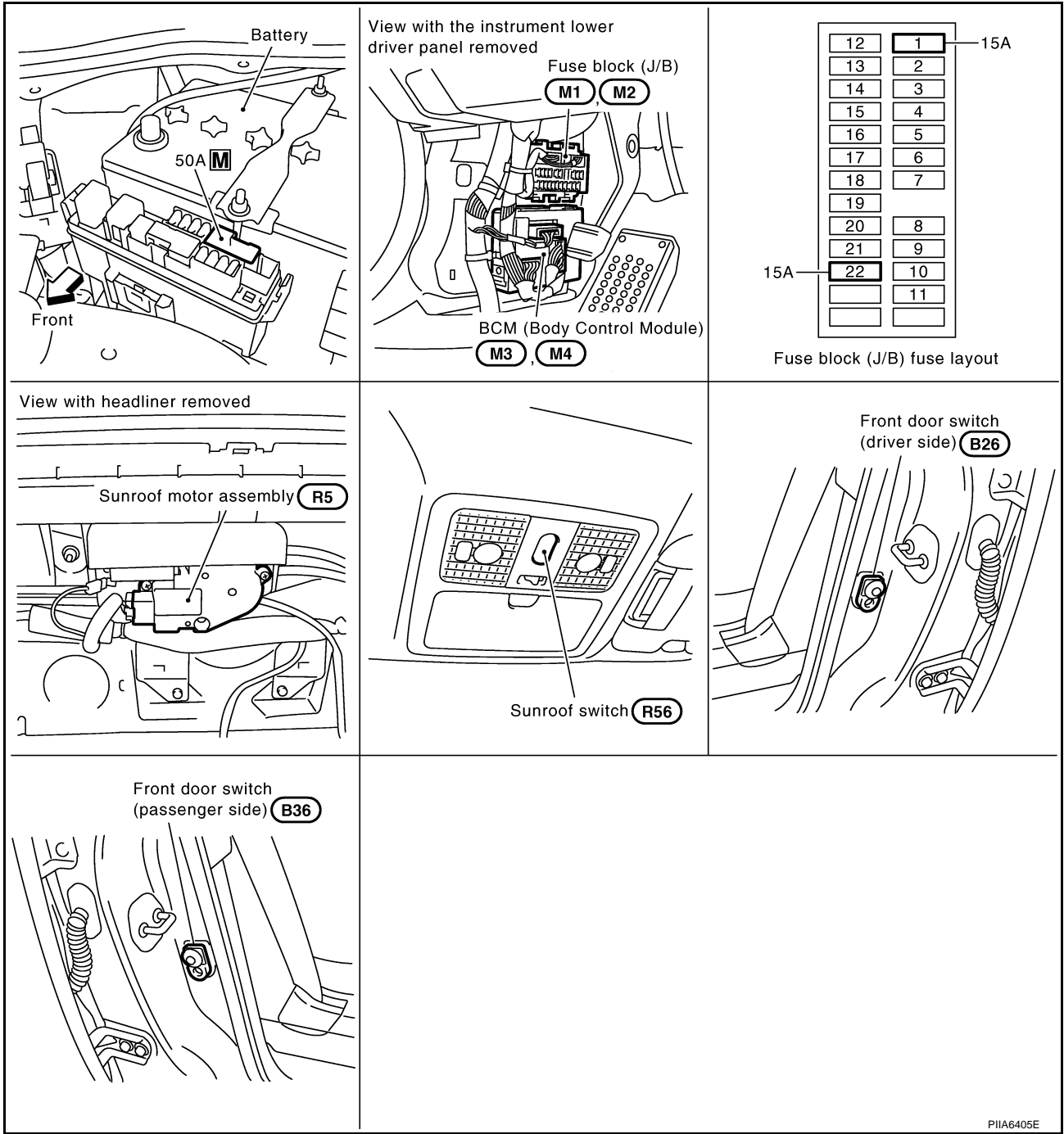

System Description

Power supplied at all time

- through 50A fusible link (letter **M** , located in the fuse and fusible link box)
- to BCM terminal 55.
- through 15A fuse [No.22, located in the fuse block (J/B)]
- to BCM terminal 42.
- through BCM terminal 54
- to sunroof motor assembly terminal 7.

When ignition switch ON or START position,
Power is supplied

- through 15A fuse [No.1, located in the fuse block (J/B)]
- to BCM terminal 38.
- through BCM terminal 53
- to sunroof motor assembly terminal 9.

Ground is supplied

- to BCM terminal 49 and 52
- through body grounds M35, M45, M85 and R6.

TILT UP / SLIDE CLOSE OPERATION

When tilt up / slide close switch is pressed,
Ground is supplied

- to sunroof motor assembly terminal 1
- through sunroof switch terminal 3
- through sunroof switch terminal 2
- through body grounds M35, M45, M85 and R6.

Then, the sunroof tilt up / slide close.

TILT DOWN / SLIDE OPEN OPERATION

When tilt down / slide open switch is pressed,
Ground is supplied

- to sunroof motor assembly terminal 5
- through sunroof switch terminal 1
- through sunroof switch terminal 2
- through body grounds M35, M45, M85 and R6.

Then, the sunroof tilt down / slide open.

AUTO OPERATION

The power sunroof AUTO feature makes it possible to slide open and slide close or tilt up and tilt down the sunroof without holding the sunroof switch in the down or up / tilt up or tilt down position.

RETAINED POWER OPERATION

When the ignition switch is turned to OFF position from ON position, power is supplied for 45 seconds.

- through BCM terminal 53.
- to sunroof motor assembly terminal 9.

When power is supplied, the sunroof can be operated.

The retained power operation is canceled when the driver or passenger side door is opened.

RAP signal period can be changed by CONSULT-II. Refer to [RF-16, "CONSULT-II Inspection Procedure"](#) .

A

B

C

D

E

F

G

H

RF

J

K

L

M

SUNROOF

ANTI-PINCH FUNCTION

The CPU of sunroof motor monitors the sunroof motor operation and the sunroof position (fully-closed or other) by the signals from sunroof motor.

When sunroof motor detects an interruption during the following slide close and tilt down operation, sunroof switch controls the motor for open and the sunroof will operate until full up position (when tilt down operate) or 125 mm (4.92 in) or more in an open direction (when slide close operate).

- close operation and tilt down when ignition switch is in the ON position.
- close operation and tilt down during retained power operation.

MEMORY RESET PROCEDURE

1. Please observe the following instructions while confirming the sunroof operation.

NOTE:

Do not disconnect the electronic power while the sunroof is operating or within 5 seconds after the sunroof stops. (to wipe-out the memory of lid position and operating friction.)

2. Initialization of system should be conducted after the following conditions.
 - When the battery is out or connector is disconnected while sunroof is operating or within 5 seconds after sunroof stops.
 - When the sunroof motor is changed.
 - When an emergency handle is used.
 - When the sunroof does not operate normally. (Incomplete initialization conditions)

INITIALIZATION PROCEDURE

If the sunroof does not close or open automatically, use the following procedure to return sunroof operation to normal.

1. Close the sunroof if it is not in the closed position. It may be necessary to repeatedly push the switch to close the sunroof.
2. Press and hold the TILT UP switch. Do not release the switch, keep pressure on it. After 10 seconds of depressing, the sunroof will tilt up, then tilt down. Release the button.
3. Press and hold the TILT UP switch again. Do not release the switch, keep pressure on it. While depressing the switch, the sunroof will "Slide open" "Slide close" "Tilt up" "Tilt down". Release the button after the sunroof "Tilts down" and stops.
4. Initializing procedure is complete. Confirm proper operation of the sunroof (slide open, slide close, tilt up, tilt down.)

CAN Communication System Description

AIS003LO

CAN (Controller Area Network) is a serial communication line for real time application. It is an on-vehicle multiplex communication line with high data communication speed and excellent error detection ability. Many electronic control units are equipped onto a vehicle, and each control unit shares information and links with other control units during operation (not independent). In CAN communication, control units are connected with 2 communication lines (CAN H line, CAN L line) allowing a high rate of information transmission with less wiring. Each control unit transmits/receives data but selectively reads required data only.

CAN Communication Unit

AIS003LP

Refer to [LAN-6, "CAN COMMUNICATION"](#) .

A

B

C

D

E

F

G

H

RF

J

K

L

M

SUNROOF

AIS003CV

Wiring Diagram — SROOF —

RF-SROOF-01

▬ : DATA LINE

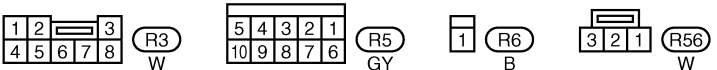
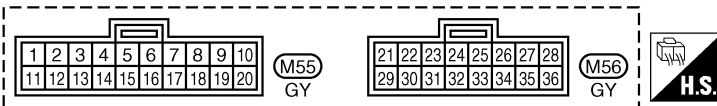
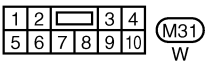
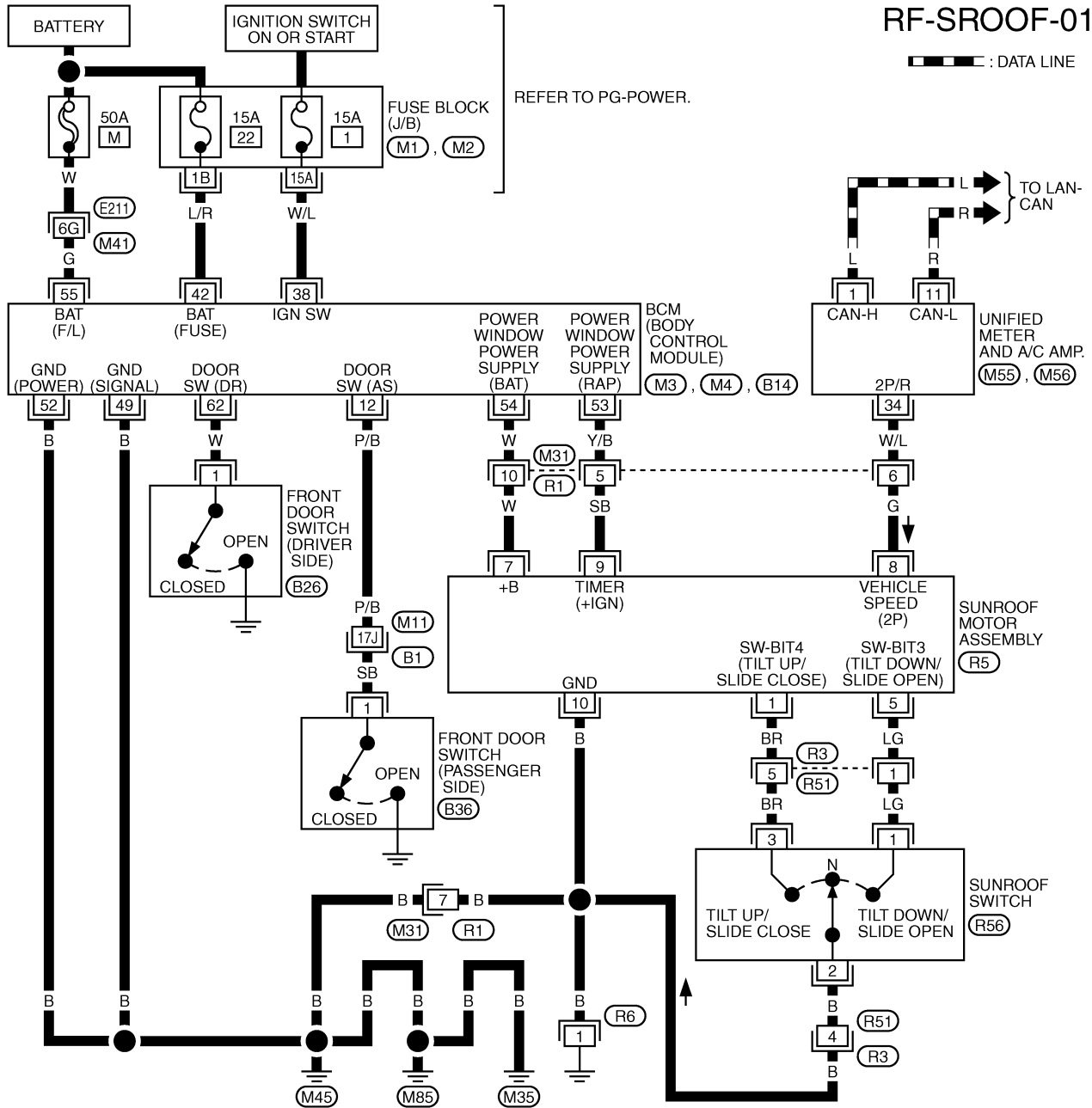

REFER TO THE FOLLOWING.
 (E211), (B1) -SUPER MULTIPLE JUNCTION (SMJ)
 (M1), (M2) -FUSE BLOCK-JUNCTION BOX (J/B)
 (M3), (M4), (B14) -ELECTRICAL UNITS

TIWH0067E

SUNROOF

Terminals and Reference Value for BCM

AIS003CW

Terminal	Wire color	Item	Condition	Voltage (V) (Approx.)
12	P/B	Front door switch (passenger side)	OPEN (ON)	0
			CLOSE (OFF)	Battery voltage
38	W/L	Ignition switch (ON)	Ignition switch (ON or START) position	Battery voltage
42	L/R	Power source (Fuse)	—	Battery voltage
49	B	Ground (signal)	—	0
52	B	Ground (power)	—	0
53	Y/B	RAP signal	Ignition switch ON	Battery voltage
			Within 45 seconds after ignition switch is turned to OFF position	Battery voltage
			When driver side or passenger side door open in power window timer is operates.	0
54	W	Power window power supply	—	Battery voltage
55	G	Power source (Fusible link)	—	Battery voltage
62	W	Front door switch driver side signal	OPEN (ON)	0
			CLOSE (OFF)	Battery voltage

Terminals and Reference Value for Sunroof Motor Assembly

AIS003CX

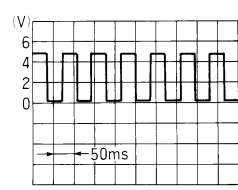
Terminal	Wire color	Item	Condition	Voltage (V) (Approx.)
1	BR	Sunroof (Tilt up/Slide close) switch signal	Ignition switch ON and sunroof switch in TILT UP / SLIDE CLOSE position	0
			Other than above	Battery voltage
5	LG	Sunroof (Tilt down/Slide open) switch signal	Ignition switch ON and sunroof switch in TILT DOWN / SLIDE OPEN position	0
			Other than above	Battery voltage
7	W	Power window power supply	—	Battery voltage
8	G	Vehicle speed signal	Speedometer operated [When vehicle speed is approx. 40 km/h (25 MPH)]	
9	SB	RAP signal	Ignition switch ON	Battery voltage
			Within 45 seconds after ignition switch is turned to OFF position	Battery voltage
			When driver side or passenger side door open in power window timer is operates.	0
10	B	Ground	—	0

Work Flow

1. Check the symptom and customer's requests.
2. Understand the outline of system. Refer to [RF-11, "System Description"](#) .
3. According to the trouble diagnosis chart, repair or replace the cause of the malfunction. Refer to [RF-18, "Trouble Diagnosis Chart by Symptom"](#) .
4. Does sunroof system operate normally? If Yes, GO TO 5. If No, GO TO 3.
5. INSPECTION END.

CONSULT-II Inspection Procedure

CAUTION:

If CONSULT-II is used with no connection of CONSULT-II CONVERTER, malfunctions might be detected in self-diagnosis depending on control unit which carry out CAN communication.

1. Turn ignition switch ON.
2. Connect "CONSULT-II and CONSULT-II CONVERTER" to the data link connector.

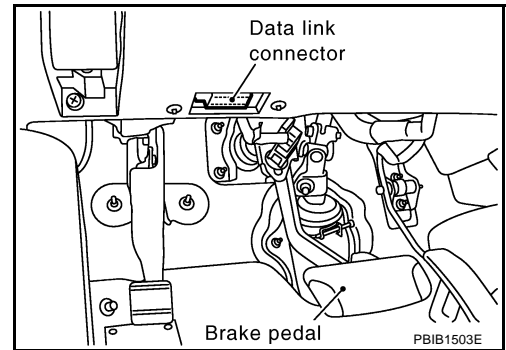

3. Turn ignition switch ON.
4. Touch "START (NISSAN BASED VHCL)".

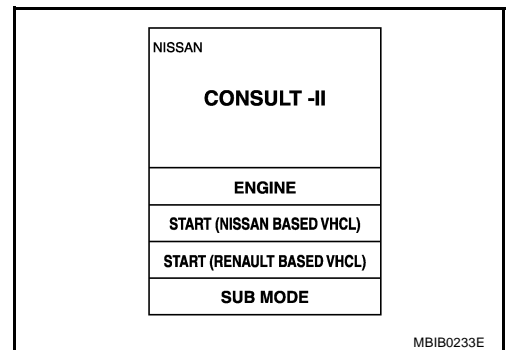

5. Touch "BCM".
If "BCM" is not indicated, go to [GI-40, "CONSULT-II Data Link Connector \(DLC\) Circuit"](#) .

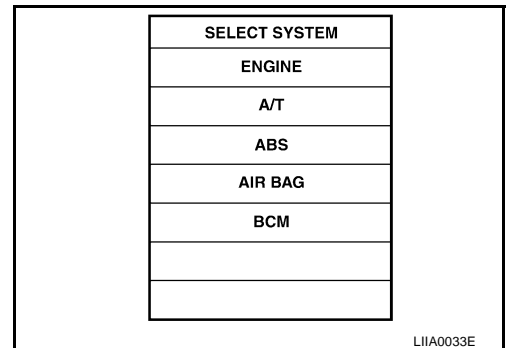

SUNROOF

6. Touch "RETAINED PWR".

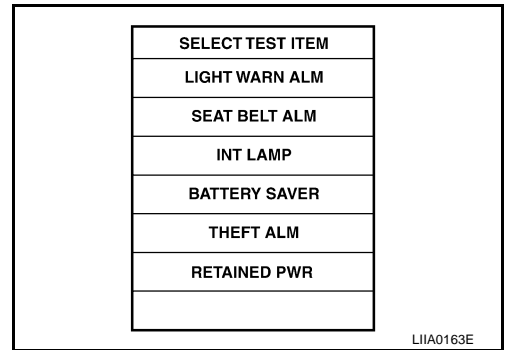

7. Select diagnosis mode. "ACTIVE TEST", "WORK SUPPORT" and "DATA MONITOR" are available.

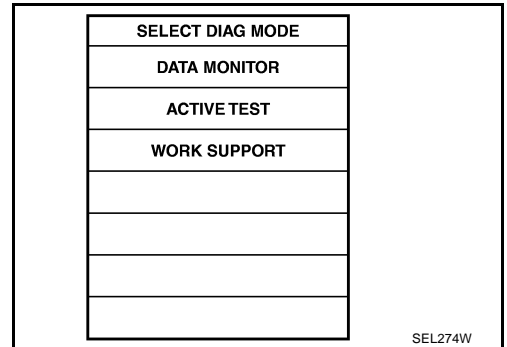

ACTIVE TEST

Test Item	Description
RETAINED PWR	<p>This test is able to supply RAP signal (power) from BCM (body control module) to power window system and power sunroof system (if equipped). Those systems can be operated when turning on "RETAINED PWR" on CONSULT-II screen even if the ignition switch is turned OFF.</p> <p>NOTE: During this test, CONSULT-II can be operated with ignition switch in OFF position. "RETAINED PWR" should be turned ON or OFF on CONSULT-II screen when ignition switch is ON. Then turn ignition switch OFF to check retained power operation. CONSULT-II might be stuck if "RETAINED PWR" is turned to ON or OFF on CONSULT-II screen when ignition switch is OFF.</p>

WORK SUPPORT

Work item	Description
RETAINED PWR	<p>Rap signal's power supply period can be changed by mode setting. Selects rap signal's power supply period between three steps</p> <ul style="list-style-type: none"> ● MODE1 (45 sec.) / MODE2 (OFF) / MODE 3 (2 min.).

DATE MONITOR

Monitor item	Description
IGN ON SW	Indicates [ON / OFF] condition of ignition switch
DOOR SW-DR	Indicates [ON / OFF] condition of front door switch driver side
DOOR SW-AS	Indicates [ON / OFF] condition of front door switch passenger side

SUNROOF

Trouble Diagnosis Chart by Symptom

AIS003D0

Symptom	Diagnostic procedure and repair order	Refer to page
Sunroof does not operate.	1. Power supply and ground circuit check of BCM	RF-18
	2. Sunroof motor assembly power supply and ground circuit check	RF-19
	3. Sunroof switch system check	RF-20
	4. Replace sunroof motor assembly.	RF-29
Motor does not stop at the sunroof fully -open or fully-closed position.	1. Initialization procedure check.	RF-12
	2. Replace sunroof motor assembly.	RF-29
Retained power operation does not operate properly.	1. Check the retained power operation mode setting.	RF-17
	2. Door switch check.	RF-22
	3. Replace sunroof motor assembly.	RF-29
Sunroof does not operate the interruption detection function.	1. Replace sunroof motor assembly.	RF-29

Power Supply and Ground Circuit Check of BCM

AIS003D1

1. CHECK FUSE

- Check 15A fuse [No.1, located in the fuse block (J/B)]
- Check 15A fuse [No.22, located in the fuse block (J/B)]
- Check 50A fusible link (letter **M** located in the fuse and fusible link box).

NOTE:

Refer to [RF-10, "Component Parts and Harness Connector Location"](#) .

OK or NG

OK >> GO TO 2.

NG >> If fuse is blown out, be sure to eliminate cause of malfunction before installing new fuse. Refer to [RF-10, "Component Parts and Harness Connector Location"](#) .

2. CHECK POWER SUPPLY CIRCUIT

1. Turn ignition switch ON.
2. Check voltage between BCM connector M3, M4 terminal 38, 42, 55 and ground.

38 (W/L) – Ground : Battery voltage

42 (L/R) – Ground : Battery voltage

55 (G) – Ground : Battery voltage

OK or NG

OK >> GO TO 3.

NG >> Check BCM power supply circuit for open or short.

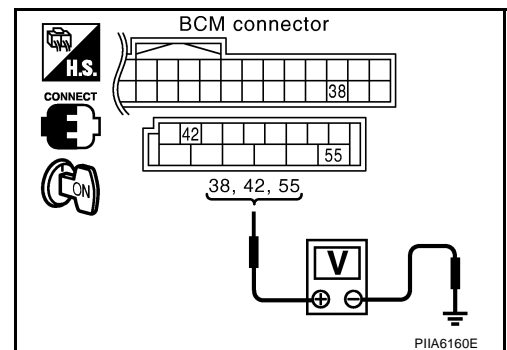

SUNROOF

3. CHECK GROUND CIRCUIT

1. Turn ignition switch OFF.
2. Disconnect BCM connector.
3. Check continuity between BCM connector M4 terminal 49, 52 and ground.

49 (B) – Ground : Continuity should exist.

52 (B) – Ground : Continuity should exist.

OK or NG

- OK >> Power supply and ground circuit are OK.
NG >> Check BCM ground circuit for open or short.

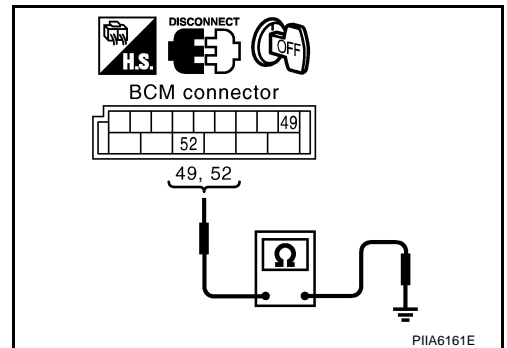

Sunroof Motor Assembly Power Supply and Ground Circuit Check

AIS003D2

1. CHECK POWER SUPPLY CIRCUIT

1. Turn ignition switch ON.
2. Check voltage between sunroof motor assembly connector R5 terminal 7, 9 and ground.

7 (W) – Ground : Battery voltage

9 (SB) – Ground : Battery voltage

OK or NG

- OK >> GO TO 2.
NG >> GO TO 3.

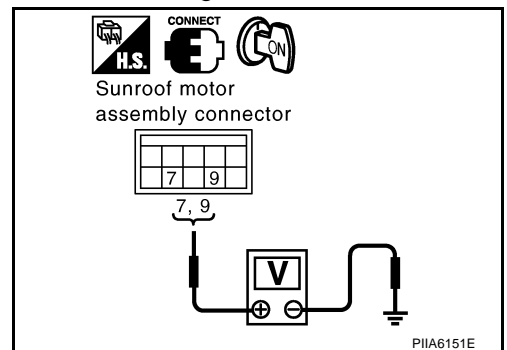

2. CHECK GROUND CIRCUIT

1. Turn ignition switch OFF.
2. Disconnect sunroof motor assembly connector.
3. Check continuity between sunroof motor assembly connector R5 terminal 10 and ground.

10 (B) – Ground : Continuity should exist.

OK or NG

- OK >> Sunroof motor assembly power supply and ground circuit are OK. Further inspection is necessary. Refer to [RF-18, "Trouble Diagnosis Chart by Symptom"](#) .
NG >> Repair or replace harness.

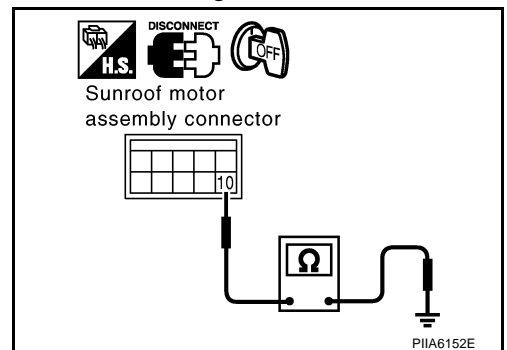

SUNROOF

3. CHECK SONROOF MOTOR CIRCUIT

1. Turn ignition switch OFF.
2. Disconnect BCM and sunroof motor assembly connector.
3. Check continuity between BCM connector M4 terminal 53, 54 and sunroof motor assembly connector R5 terminal 7, 9.

53 (Y/B) – 9 (SB) : Continuity should exist.

54 (W) – 7 (W) : Continuity should exist.

4. Check continuity between BCM connector M4 terminal 53, 54 and ground.

53 (Y/B) – Ground : Continuity should not exist.

54 (W) – Ground : Continuity should not exist.

OK or NG

OK >> GO TO 4.

NG >> Repair or replace harness.

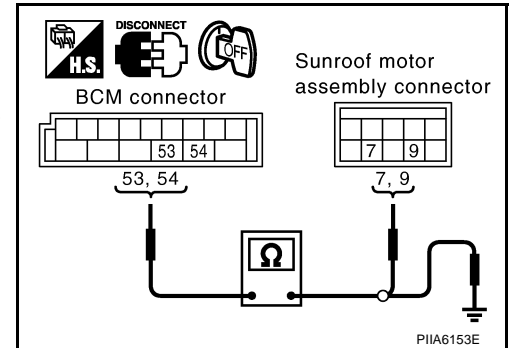

4. CHECK BCM OUTPUT SIGNAL

1. Connect BCM connector.
2. Turn ignition switch ON.
3. Check voltage between BCM connector M4 terminal 53, 54 and ground.

53 (Y/B) – Ground : Battery voltage

54 (W) – Ground : Battery voltage

OK or NG

OK >> Check condition of harness and connector.

NG >> Replace BCM.

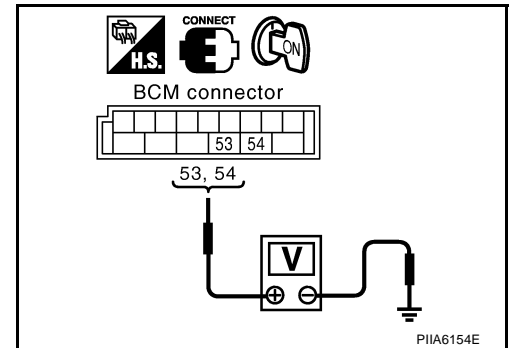

Sunroof Switch System Check

1. SUNROOF SWITCH INPUT SIGNAL CHECK

1. Turn ignition switch ON.
2. Check voltage between sunroof motor assembly connector and ground.

Connector	Terminals (Wire color)		Condition	Voltage (V) (Approx.)
	(+)	(-)		
R5	1 (BR)	Ground	Sunroof switch is operated TILT UP or SLIDE CLOSE	0
			Other than above	Battery voltage
	5 (LG)		Sunroof switch is operated TILT DOWN or SLIDE OPEN	0
			Other than above	Battery voltage

OK or NG

OK >> Replace sunroof motor assembly.

NG >> GO TO 2.

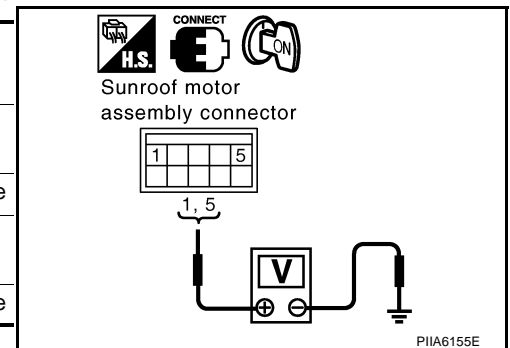

SUNROOF

2. SUNROOF SWITCH CIRCUIT CHECK

1. Turn ignition switch OFF.
2. Disconnect sunroof motor assembly and sunroof switch connector.
3. Check continuity between sunroof motor assembly connector R5 terminal 1, 5 and sunroof switch connector R56 terminal 1, 3.

1 (BR) – 3 (BR) : Continuity should exist.

5 (LG) – 1 (LG) : Continuity should exist.

OK or NG

OK >> GO TO 3.

NG >> Repair or replace harness between sunroof motor assembly and sunroof switch.

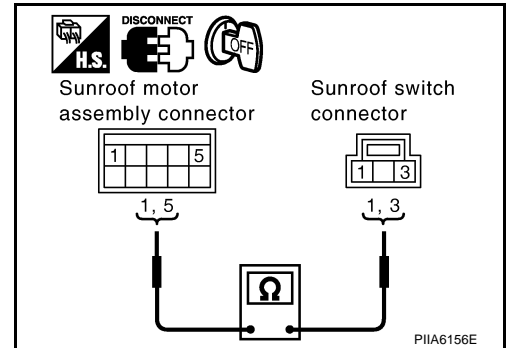

3. SUNROOF SWITCH GROUND CIRCUIT CHECK

Check continuity between sunroof switch connector R56 terminal 2 and ground.

2 (B) – Ground : Continuity should exist.

OK or NG

OK >> GO TO 4.

NG >> Repair or replace harness.

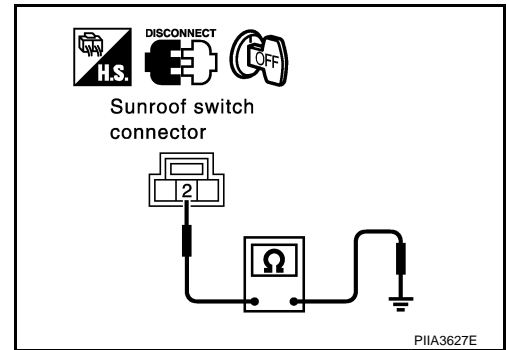

4. SUNROOF SWITCH CHECK

Check continuity between sunroof switch terminal 1, 3 and 2.

Terminals	Condition	Continuity
1	Sunroof switch is operated TILT DOWN or SLIDE OPEN	Yes
	Other than above	No
3	Sunroof switch is operated TILT UP or SLIDE CLOSE	Yes
	Other than above	No

OK or NG

OK >> Replace sunroof motor assembly.

NG >> Replace sunroof switch.

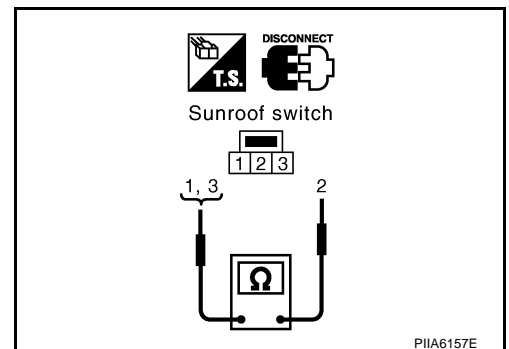

Door Switch Check

1. CHECK DOOR SWITCH INPUT SIGNAL

With CONSULT-II

Check ("DOOR SW-DR" and "DOOR SW-AS") in "DATA MONITOR" mode with CONSULT-II.

Monitor item	Condition	
DOOR SW-DR	OPEN	: ON
	CLOSE	: OFF
DOOR SW-AS	OPEN	: ON
	CLOSE	: OFF

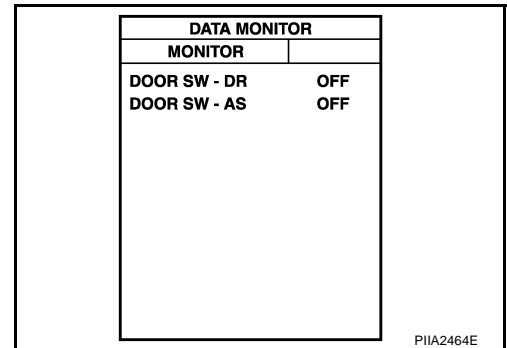

Without CONSULT-II

Check voltage between BCM connector M3, M4 terminals 12, 62 and ground.

Item	Terminals (Wire color)		Condition	Voltage (V) (Approx.)
	(+)	(-)		
Passenger side door switch	12 (P/B)	Ground	OPEN	0
			CLOSE	Battery voltage
Driver side door switch	62 (W)		OPEN	0
			CLOSE	Battery voltage

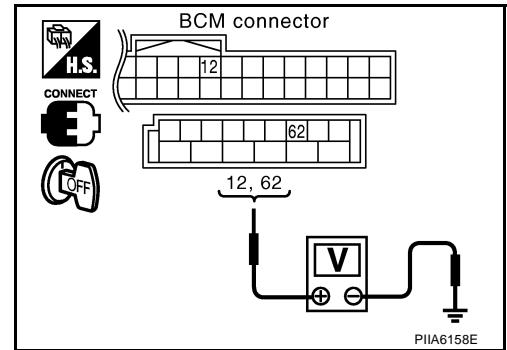

OK or NG

- OK >> Door switch is OK.
- NG >> GO TO 2.

SUNROOF

2. CHECK DOOR SWITCH CIRCUIT

1. Turn ignition switch OFF.
2. Disconnect door switch and BCM connector.
3. Check continuity between BCM connector M3, M4 terminal 12, 62 and door switch connector B26, B36 terminal 1.

Driver side door

62 (W) – 1 (W) : Continuity should exist.

Passenger side door

12 (P/B) – 1 (SB) : Continuity should exist.

4. Check continuity between BCM connector M3, M4 terminals 12, 62 and ground.

12 (P/B) – Ground : Continuity should not exist.

62 (W) – Ground : Continuity should not exist.

OK or NG

- OK >> GO TO 3.
 NG >> Repair or replace harness.

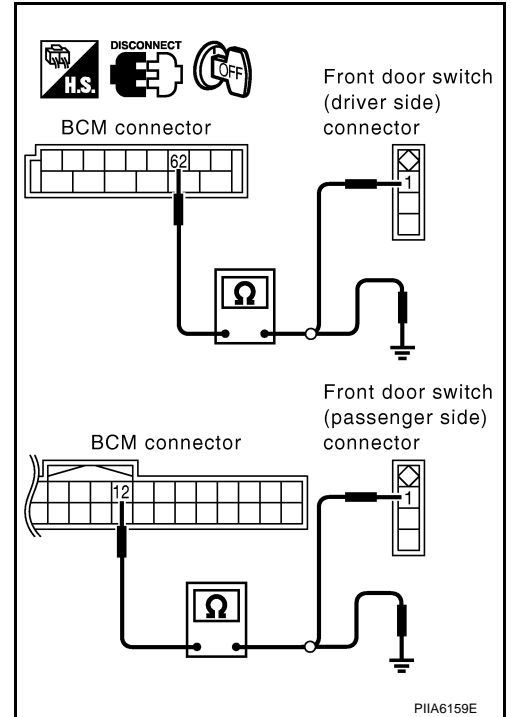

3. CHECK DOOR SWITCH

Check continuity between door switches terminal 1 and ground part of door switch.

Terminal		Door switch	Continuity
1	Ground part of door switch	Pushed	No
		Released	Yes

OK or NG

- OK >> GO TO 4.
 NG >> Replace malfunction door switch.

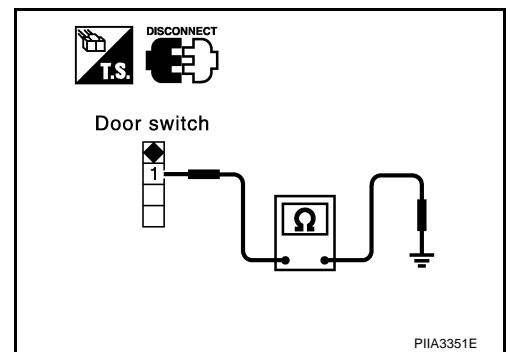

4. CHECK BCM OUTPUT SIGNAL

1. Connect BCM connector.
2. Check voltage between BCM connector M3, M4 terminal 12, 62 and ground.

12 (P/B) – Ground : Battery voltage

62 (W) – Ground : Battery voltage

OK or NG

- OK >> Further inspection is necessary. Refer to [RF-18, "Trouble Diagnosis Chart by Symptom"](#) .
 NG >> Replace BCM.

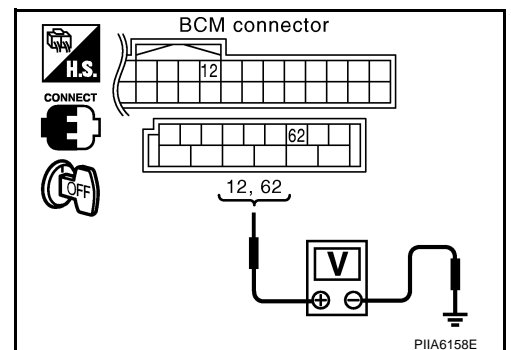

SUNROOF

Wind Deflector Inspection

AIS003BP

1. Make sure the wind deflector is properly raised by manual. If a malfunction is detected, remove and visually check it. If it is damaged, replace it with a new one. If no damage is found, reinstall it properly.

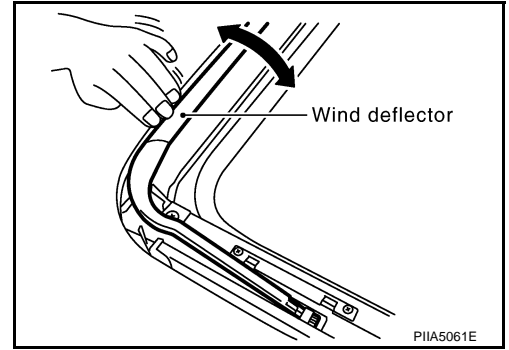

Link and Wire Assembly

AIS003BR

NOTE:

Before replacing a suspect part, carefully ensure it is the source of noise being experienced.

1. Check link to determine if coated film has peeled off to such an extent that substrate is visible. Check also to determine if link is the source of noise. If it is, replace it.
2. Visually check to determine if a sufficient amount of grease has been applied to wire or rail groove. If not, add grease as required.
3. Check wire for any damage or deterioration. If any damage is found, replace wire.

Fitting Adjustment

AIS003BR

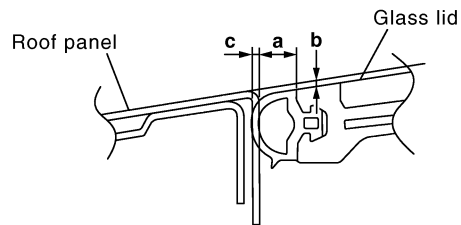
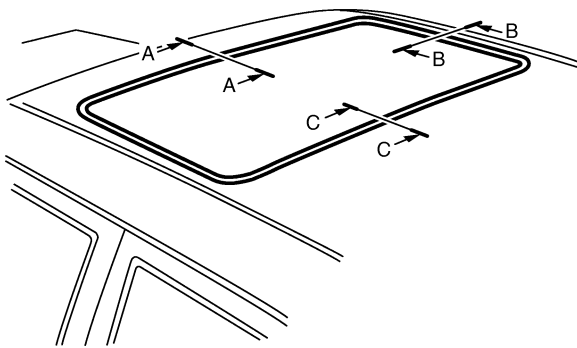

	a		b		c		
	Standard value	Lower bound value	Central value	Upper bound value	Lower bound value	Central value	Upper bound value
A - A	5.8 (0.228)	-2.4 (-0.094)	-0.9 (-0.035)	+0.6 (+0.024)	0.6 (0.024)	1.4 (0.055)	2.2 (0.087)
B - B	5.8 (0.228)	-2.4 (-0.094)	-0.9 (-0.035)	+0.6 (+0.024)	0.6 (0.024)	1.4 (0.055)	2.2 (0.087)
C - C	5.8 (0.228)	-2.4 (-0.094)	-0.9 (-0.035)	+0.6 (+0.024)	0.6 (0.024)	1.4 (0.055)	2.2 (0.087)

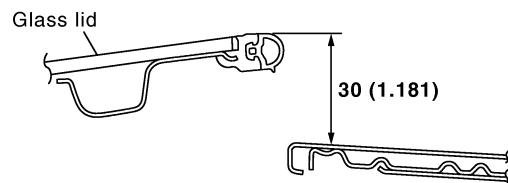
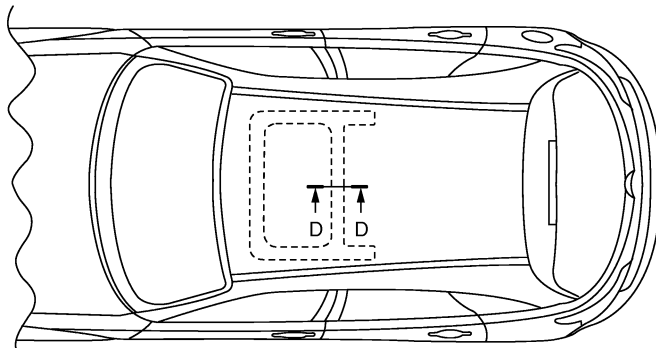

D - D (When sunroof is tilted up)

Unit: mm (in)

PIIA6188E

SUNROOF

LID WEATHERSTRIP OVERLAP ADJUSTMENT AND SURFACE MISMATCH ADJUSTMENT

1. Tilt up glass lid.
2. After loosening glass lid TORX bolts (T25) (left and right), tilt down glass lid.
3. Adjust glass lid from outside of vehicle so it resembles “A-A” “B-B” “C-C” as shown in the figure to the right.
4. To prevent glass lid from moving after adjustment, first tighten the TORX bolts (T25) of front left, and then tighten the TORX bolts (T25) of rear right.
5. Tighten remaining TORX bolts (T25), being careful to prevent glass lid from moving.
6. Tilt glass lid up and down several times to make sure it moves smoothly.

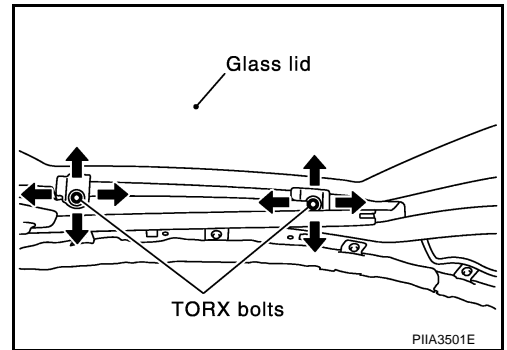

Removal and Installation

- After any adjustment, check sunroof operation and glass lid alignment.
- Handle finisher plate and glass lid with care so as not to cause damage.
- It is desirable for easy installation to mark each point before removal.

CAUTION:

- **Always work with a helper.**
- **Fully close the glass lid assembly, before removal, then do not operate motor assembly after removal.**

AIS003BS

A
B
C
D
E
F
G
H

RF

J
K
L
M

SUNROOF

SEC. 736

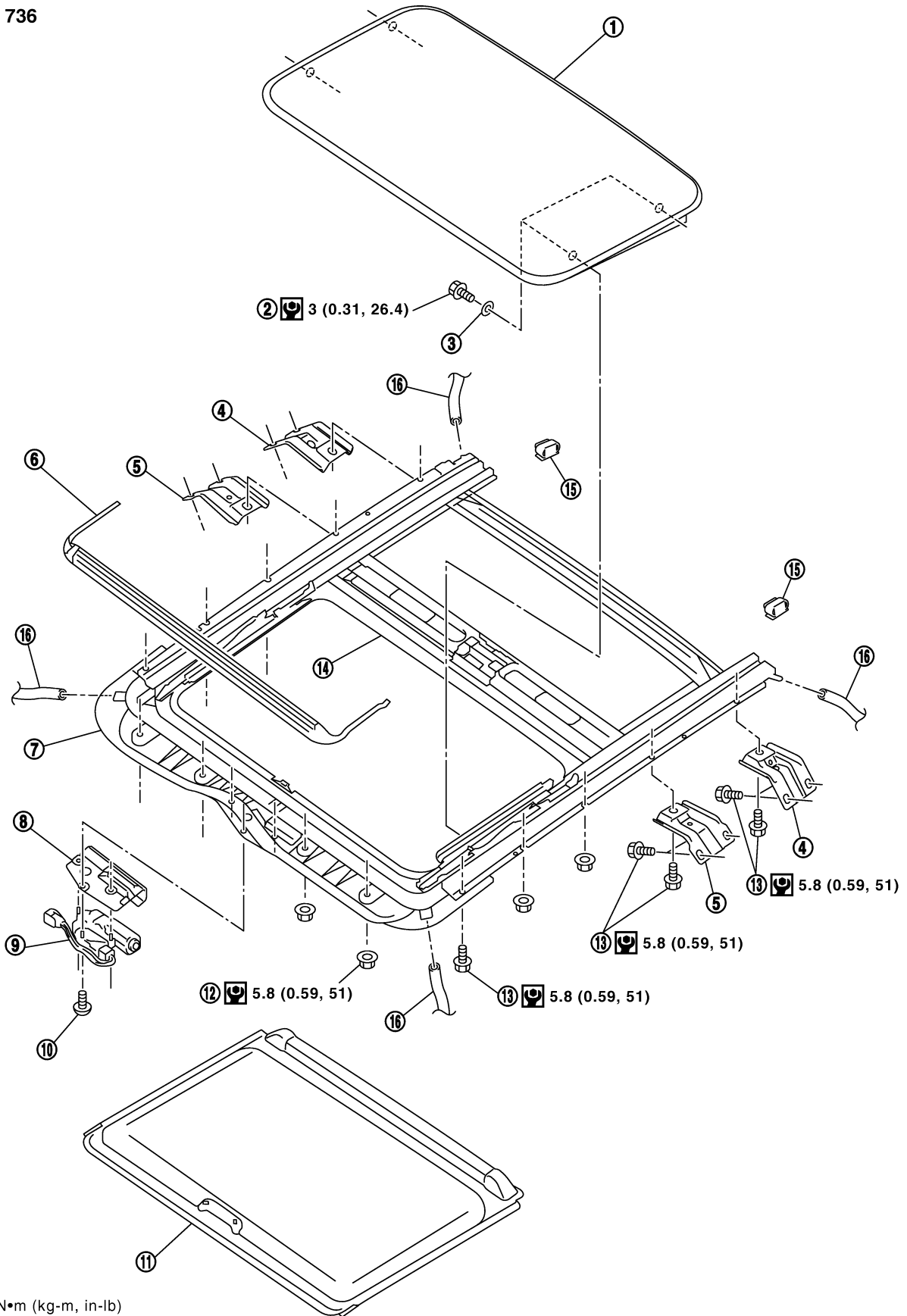

 : N•m (kg-m, in-lb)

PIIA6190E

SUNROOF

- | | | |
|--------------------------|--------------------------|---------------------------|
| 1. Glass lid | 2. TORX bolt (T25) | 3. Washer |
| 4. Rear sunroof bracket | 5. Front sunroof bracket | 6. Wind deflector |
| 7. Sunroof unit assembly | 8. Noise cover | 9. Sunroof motor assembly |
| 10. Screw | 11. Sunshade | 12. Nut |
| 13. Bolt | 14. Drain plate | 15. Sunshade stopper |
| 16. Drain hose | | |

A
B
C
D
E
F
G
H
RF
J
K
L
M

SUNROOF UNIT ASSEMBLY

Removal

CAUTION:

- Always work with a helper.
- When taking sunroof unit out, use clothes to protect the seats and trim from damage.
- After installing the sunroof unit and glass lid, be sure to perform the leakage test and make sure there is no malfunction.

1. Tilt up glass lid.
2. Remove the headlining. Refer to [EI-42, "Removal and Installation"](#).
3. Disconnect drain hoses.
4. Remove glass lid. Refer to [RF-28, "GLASS LID"](#).
5. Remove motor mounting screws. Remove sunroof motor assembly and disconnect harness connector.

CAUTION:

- Before removing sunroof motor assembly, make sure that sunroof is fully closed.
- After removing sunroof motor assembly, do not attempt to rotate sunroof motor as a single unit.

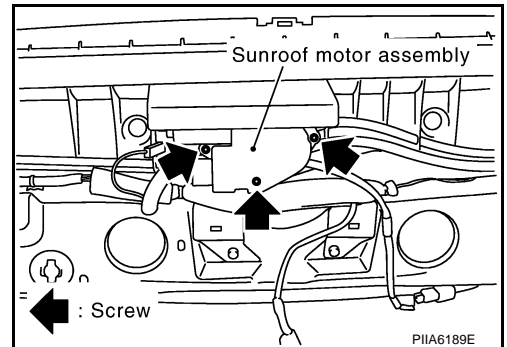

6. Remove nuts on the front end and side rail.

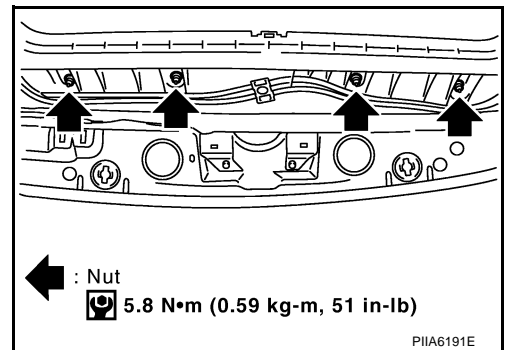

7. Remove curtain air bag bracket bolts, then remove curtain air bag bracket from the rail side. Refer to [SRS-41, "Removal and Installation"](#).
8. Remove front/rear sunroof bracket bolts, then remove sunroof unit assembly from roof panel.

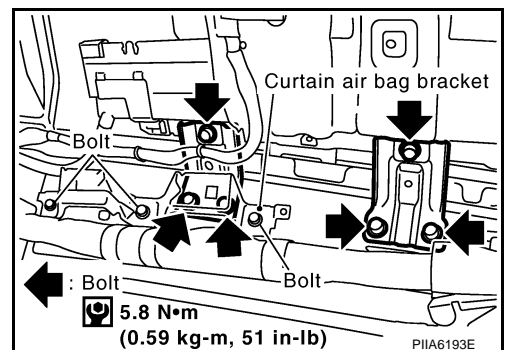

9. Remove sunroof unit assembly through the passenger room while being careful not to damage the seats and trim.

SUNROOF

Installation

1. Temporarily tighten the mounting bolts on the front/rear sunroof brackets (RH/LH).

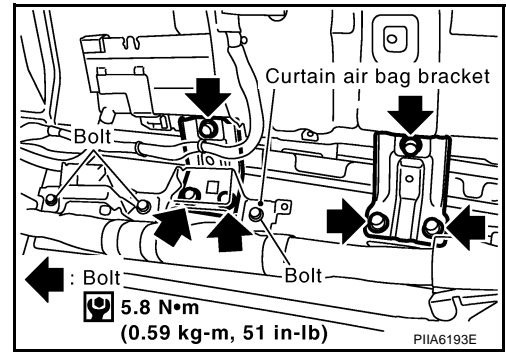

2. Bring sunroof unit assembly into passenger room and place the rear end of the rail onto the sunroof brackets.
3. Tighten the mounting nuts on the front end.

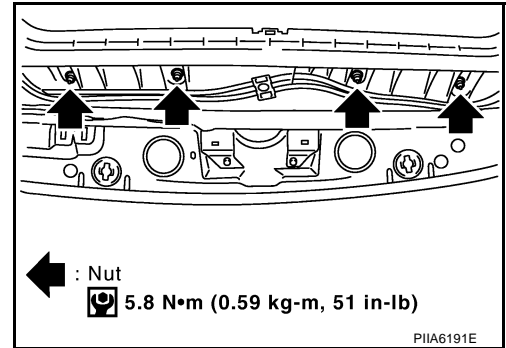

4. Tighten the installation points diagonally excluding the installation point of the sunroof bracket around the roof opening.
5. Tighten the bolts on the sunroof bracket to the vehicle side and then tighten the bolt to the rail side.
6. Tighten the bolts on the curtain air bag bracket to the rail side. Refer to [SRS-41, "Removal and Installation"](#).

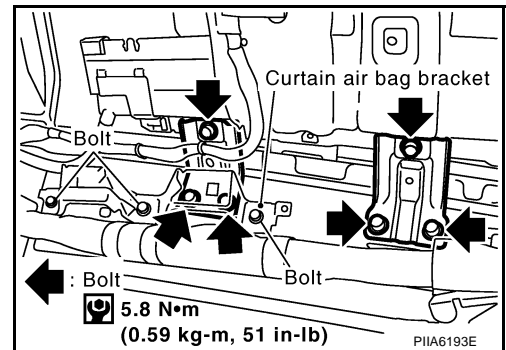

GLASS LID

Removal

1. Tilt up glass lid.
2. Remove TORX bolts (T25) from remove glass lid.

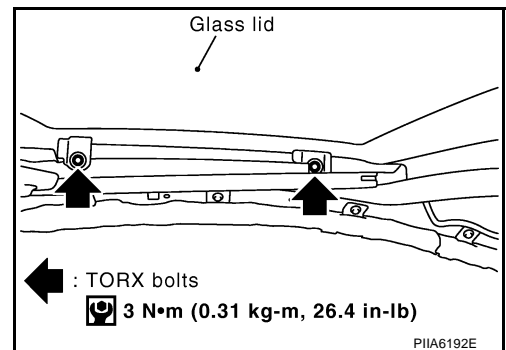

Installation

1. Tighten bolts diagonally on the glass lid.
2. After installation, carry out fitting adjustment.

SUNROOF

SUNSHADE

Removal

NOTE:

Detaching is possible even with the sunshade attached on the vehicle.

1. Remove the headlining. Refer to [EI-42, "Removal and Installation"](#) .
2. Remove sunshade stopper.
3. The protection tape is pasted to the sunshade knob.
4. Pull sunshade out of the rear end of the sunroof frame, and remove it from the frame.

CAUTION:

Do not damage the sunshade and sunshade knob while lifting up a little.

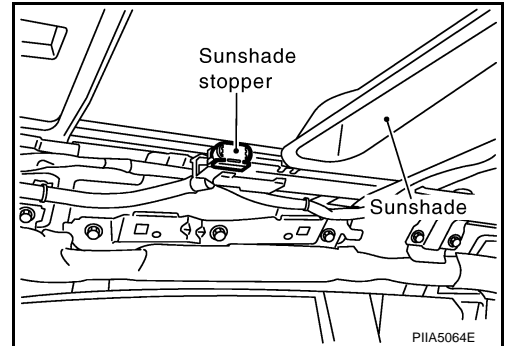

Installation

Install in the reverse order of removal.

WIND DEFLECTOR

Removal

NOTE:

Detaching is possible even with the wind deflector attached on the vehicle.

1. The sunroof is opened.
2. Remove spring hinge screws, then remove hinge from the frame.
3. Remove the wind deflector.

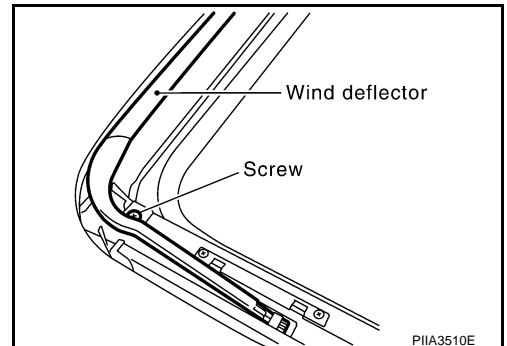

Installation

Install in the reverse order of removal.

SUNROOF MOTOR ASSEMBLY

Removal

1. Remove headlining. Refer to [EI-42, "Removal and Installation"](#) .
2. Remove motor mounting screw.
3. Disconnect harness connector from sunroof motor assembly, then remove sunroof motor assembly.

CAUTION:

- When removing the sunroof motor assembly, be sure that the sunroof is in the fully closed position.
- Do not run the removed sunroof motor assembly as a single unit.

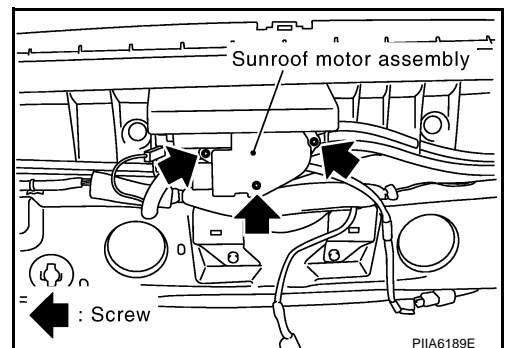

SUNROOF

Installation

Move the sunroof motor assembly laterally little by little so that the gear is completely engaged into the wire on the sunroof unit assembly and the mounting surface becomes parallel. Then secure the sunroof motor assembly with screws.

CAUTION:

- Before installing the sunroof motor assembly, be sure to place the link and wire assembly in the symmetrical and fully closed position.

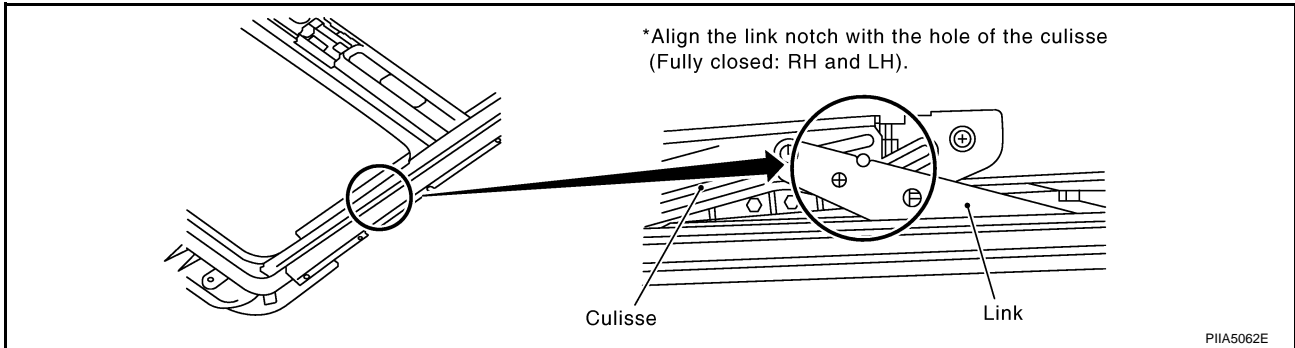

- Confirm the body ground of the noise cover is connected.

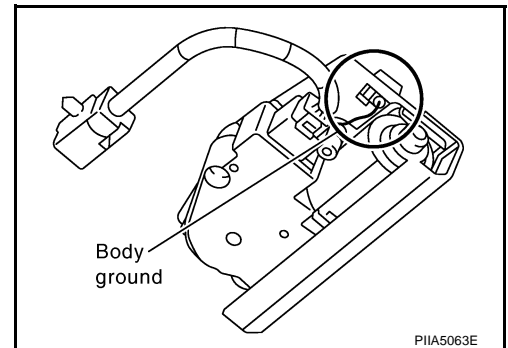

- Initialization of it after installing the sunroof motor. Refer to [RF-12, "INITIALIZATION PROCEDURE"](#)