

**SECTION** **ST**  
**STEERING SYSTEM**

A  
 B  
 C  
 D  
 E  
 F  
**ST**  
 H  
 I  
 J  
 K  
 L  
 M  
 N  
 O  
 P

**CONTENTS**

<p><b>SYMPTOM DIAGNOSIS</b> ..... 2</p> <p><b>NOISE, VIBRATION AND HARSHNESS (NVH) TROUBLESHOOTING</b> ..... 2</p> <p style="padding-left: 20px;">NVH Troubleshooting Chart .....2</p> <p><b>PRECAUTION</b> ..... 3</p> <p><b>PRECAUTIONS</b> ..... 3</p> <p style="padding-left: 20px;">Precaution for Supplemental Restraint System (SRS) "AIR BAG" and "SEAT BELT PRE-TENSIONER" .....3</p> <p style="padding-left: 20px;">Precautions For High-Voltage System .....3</p> <p style="padding-left: 20px;">Necessary for Steering Wheel Rotation after Battery Disconnect .....3</p> <p style="padding-left: 20px;">Service Notice or Precautions .....4</p> <p><b>PREPARATION</b> ..... 5</p> <p><b>PREPARATION</b> ..... 5</p> <p style="padding-left: 20px;">Special Service Tool .....5</p> <p style="padding-left: 20px;">Commercial Service Tool .....5</p> <p><b>ON-VEHICLE MAINTENANCE</b> ..... 6</p> <p><b>STEERING WHEEL</b> ..... 6</p> <p style="padding-left: 20px;">Inspection .....6</p> <p><b>ON-VEHICLE REPAIR</b> ..... 8</p> <p><b>STEERING WHEEL</b> ..... 8</p>	<p style="padding-left: 20px;">Removal and Installation ..... 8</p> <p><b>STEERING COLUMN</b> ..... 9</p> <p style="padding-left: 20px;">Exploded View ..... 9</p> <p style="padding-left: 20px;">Removal and Installation ..... 9</p> <p><b>STEERING GEAR AND LINKAGE</b> ..... 12</p> <p style="padding-left: 20px;">Exploded View .....12</p> <p style="padding-left: 20px;">Removal and Installation .....12</p> <p><b>DISASSEMBLY AND ASSEMBLY</b> ..... 14</p> <p><b>STEERING COLUMN</b> .....14</p> <p style="padding-left: 20px;">Disassembly and Assembly .....14</p> <p><b>STEERING GEAR AND LINKAGE</b> ..... 15</p> <p style="padding-left: 20px;">Exploded View .....15</p> <p style="padding-left: 20px;">Disassembly .....15</p> <p style="padding-left: 20px;">Inspection .....15</p> <p style="padding-left: 20px;">Assembly .....16</p> <p><b>SERVICE DATA AND SPECIFICATIONS (SDS)</b> ..... 17</p> <p><b>SERVICE DATA AND SPECIFICATIONS (SDS)</b> ..... 17</p> <p style="padding-left: 20px;">Steering Wheel .....17</p> <p style="padding-left: 20px;">Steering Angle .....17</p> <p style="padding-left: 20px;">Steering Column .....17</p> <p style="padding-left: 20px;">Steering Gear .....18</p>
--	---

# NOISE, VIBRATION AND HARSHNESS (NVH) TROUBLESHOOTING

< SYMPTOM DIAGNOSIS >

## SYMPTOM DIAGNOSIS

### NOISE, VIBRATION AND HARSHNESS (NVH) TROUBLESHOOTING

#### NVH Troubleshooting Chart

INFOID:000000004212793

Use chart below to help you find the cause of the symptom. If necessary, repair or replace these parts.

Symptom		Steering	Possible cause and SUSPECTED PARTS											Reference page												
			Outer socket ball joint swinging force	Outer socket ball joint rotating torque	Outer socket ball joint end play	Steering wheel play	Steering gear rack sliding force	Improper steering wheel	Mounting rubber deterioration	Steering column deformation or damage	Improper installation or looseness of steering column	Steering linkage looseness	WHEEL HUB AND AXLE		SUSPENSION	TIRES	ROAD WHEEL	DRIVE SHAFT	BRAKES							
Noise	Shake	Vibration	Shimmy	Shudder	x	x	x	x	x													ST-15				
																									ST-15	
																										ST-15
																										ST-6
																										ST-15
																						—				
																						ST-12				
																						ST-14				
																						ST-9				
																						ST-12				
																						<a href="#">FAX-2, "NVH Troubleshooting Chart"</a>				
																						<a href="#">FSU-2, "NVH Troubleshooting Chart"</a>				
																						<a href="#">WT-57, "NVH Troubleshooting Chart"</a>				
																						<a href="#">WT-57, "NVH Troubleshooting Chart"</a>				
																						<a href="#">FAX-2, "NVH Troubleshooting Chart"</a>				
																						<a href="#">BR-6, "NVH Troubleshooting Chart"</a>				

x: Applicable

# PRECAUTIONS

< PRECAUTION >

## PRECAUTION

### PRECAUTIONS

#### Precaution for Supplemental Restraint System (SRS) "AIR BAG" and "SEAT BELT PRE-TENSIONER"

INFOID:000000004212794

The Supplemental Restraint System such as "AIR BAG" and "SEAT BELT PRE-TENSIONER", used along with a front seat belt, helps to reduce the risk or severity of injury to the driver and front passenger for certain types of collision. This system includes seat belt switch inputs and dual stage front air bag modules. The SRS system uses the seat belt switches to determine the front air bag deployment, and may only deploy one front air bag, depending on the severity of a collision and whether the front occupants are belted or unbelted. Information necessary to service the system safely is included in the SR and SB section of this Service Manual.

#### **WARNING:**

- To avoid rendering the SRS inoperative, which could increase the risk of personal injury or death in the event of a collision which would result in air bag inflation, all maintenance must be performed by an authorized NISSAN/INFINITI dealer.
- Improper maintenance, including incorrect removal and installation of the SRS, can lead to personal injury caused by unintentional activation of the system. For removal of Spiral Cable and Air Bag Module, see the SR section.
- Do not use electrical test equipment on any circuit related to the SRS unless instructed to in this Service Manual. SRS wiring harnesses can be identified by yellow and/or orange harnesses or harness connectors.

#### Precautions For High-Voltage System

INFOID:000000004212795

Refer to [GI-24. "Precautions For High-Voltage System"](#).

#### Necessary for Steering Wheel Rotation after Battery Disconnect

INFOID:000000004212796

#### **NOTE:**

- Before removing and installing any control units, first turn the push-button ignition switch to the LOCK position, then disconnect both battery cables.
- After finishing work, confirm that all control unit connectors are connected properly, then re-connect both battery cables.
- Always use CONSULT-III to perform self-diagnosis as a part of each function inspection after finishing work. If a DTC is detected, perform trouble diagnosis according to self-diagnosis results.

This vehicle is equipped with a push-button ignition switch and a steering lock unit.

If the battery is disconnected or discharged, the steering wheel will lock and cannot be turned.

If turning the steering wheel is required with the battery disconnected or discharged, follow the procedure below before starting the repair operation.

#### OPERATION PROCEDURE

1. Connect both battery cables.

#### **NOTE:**

Supply power using jumper cables if battery is discharged.

2. Carry the Intelligent Key or insert it to the key slot and turn the push-button ignition switch to ACC position. (At this time, the steering lock will be released.)
3. Disconnect both battery cables. The steering lock will remain released with both battery cables disconnected and the steering wheel can be turned.
4. Perform the necessary repair operation.
5. When the repair work is completed, re-connect both battery cables. With the brake pedal released, turn the push-button ignition switch from ACC position to ON position, then to LOCK position. (The steering wheel will lock when the push-button ignition switch is turned to LOCK position.)
6. Perform self-diagnosis check of all control units using CONSULT-III.

# PRECAUTIONS

< PRECAUTION >

## Service Notice or Precautions

INFOID:000000004212797

- In case of removing steering gear assembly, make the final tightening with grounded and unloaded vehicle condition, and then check wheel alignment.
- Observe the following precautions when disassembling.
  - Before disassembly, thoroughly clean the outside of the unit.
  - Disassembly should be done in a clean work area. It is important to prevent the internal parts from becoming contaminated by dirt or other foreign matter.
  - For easier and proper assembly, place disassembled parts in order on a parts rack.
  - Use nylon cloth or paper towels to clean the parts; common shop rags can leave lint that might interfere with their operation.
  - Do not reuse non-reusable parts.
  - Before assembling, apply the specified grease to the directed parts.
- Perform EPS motor angle sensor initialization and torque sensor calibration when replacing steering gear assembly. Refer to [STC-5. "EPS MOTOR ANGLE SENSOR INITIALIZATION AND TORQUE SENSOR CALIBRATION : Special Repair Requirement"](#).

# PREPARATION

< PREPARATION >

## PREPARATION

### PREPARATION

#### Special Service Tool

INFOID:000000004212798

The actual shapes of Kent-Moore tools may differ from those of special service tools illustrated here.

Tool number (Kent-Moore No.) Tool name	Description
ST27180001 (J-25726-A) Steering wheel puller	Removing steering wheel
ST3127S000 (See J-25765-A) Preload gauge 1. GG9103000 (J-25765-A) Torque wrench 2. HT62940000 ( - ) Socket adapter 3. HT62900000 ( - ) Socket adapter	Inspecting of rotating torque for ball joint and steering column
— (J-44372) Pull gauge	Measuring steering wheel turning force, rack sliding force and ball joint swinging force
HT72520000 (J-25730-A) Ball joint remover	Removing ball joint

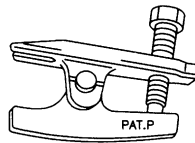
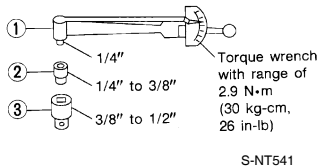
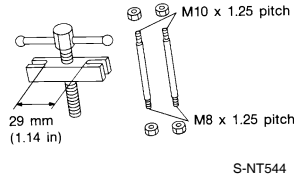

#### Commercial Service Tool

INFOID:000000004212799

Tool number Tool name	Description
Power tool	<ul style="list-style-type: none"> <li>• Removing wheel nuts</li> <li>• Removing undercover</li> </ul>

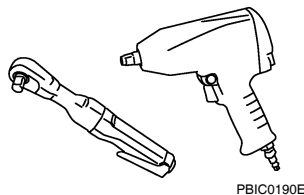

# STEERING WHEEL

< ON-VEHICLE MAINTENANCE >

## ON-VEHICLE MAINTENANCE

### STEERING WHEEL

#### Inspection

INFOID:000000004212800

#### STEERING WHEEL AXIAL END PLAY

- Check installation conditions of steering gear assembly, front suspension assembly, axle and steering column assembly.
- Check if movement exists when steering wheel is moved up and down, to the left and right and to the axial direction.

**Steering wheel axial end play : 0 mm (0 in)**

- Check steering gear assembly mounting bolts and nut for looseness. Refer to [ST-12. "Exploded View"](#).

#### STEERING WHEEL PLAY

- Turn steering wheel so that front wheels come to the straight-ahead position. Start engine and lightly turn steering wheel to the left and right until front wheels start to move. Measure steering wheel movement on the outer circumference as shown.

**Steering wheel play : 0 - 35 mm (0 - 1.38 in)**

- When the measurement value is outside the standard value, check backlash for each joint of steering column assembly and installation condition of steering gear assembly.

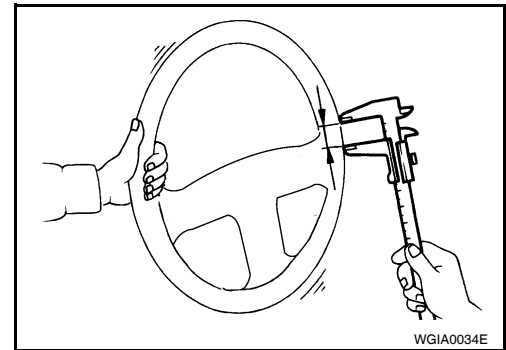

#### NEUTRAL POSITION OF STEERING WHEEL

- Make sure that steering gear assembly, steering column assembly and steering wheel are installed in the correct position.
- Perform neutral position inspection after wheel alignment. Refer to [BRC-9. "PERFORM ZERO POINT OF STEERING ANGLE SENSOR : Special Repair Requirement"](#).
- Set vehicle to the straight-ahead position and confirm steering wheel is in the neutral position.
- Loosen outer socket lock nut and turn inner socket to left and right equally to make fine adjustments if steering wheel is not in the neutral position.

#### STEERING WHEEL TURNING FORCE

1. Park vehicle on a level, dry surface and set parking brake.
2. Start engine.
3. Tires need to be inflated to normal pressure.
4. Check steering wheel turning force when steering wheel has been turned 360° from the neutral position using Tool.

**Tool Number : — (J-44372)**  
**Steering wheel turning force : 39 N (4 kg-f, 9 lb-f) or less**

5. If steering wheel turning force is out of specification, check rack sliding force. Refer to [ST-15. "Inspection"](#).
6. If rack sliding force is not within specifications, adjust rack sliding force. Refer to [ST-15. "Inspection"](#).
7. If rack sliding force is OK, inspect steering column. Refer to [ST-9. "Removal and Installation"](#).

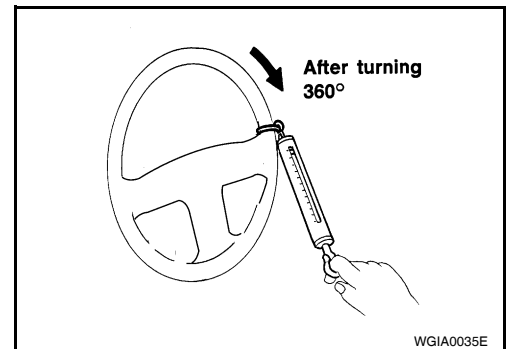

#### FRONT WHEEL TURNING ANGLE

# STEERING WHEEL

## < ON-VEHICLE MAINTENANCE >

- Check front wheel turning angle after toe-in inspection. Place front wheels on turning radius gauges and rear wheels on stands. Check the maximum inner and outer wheel turning angles for LH and RH road wheels.

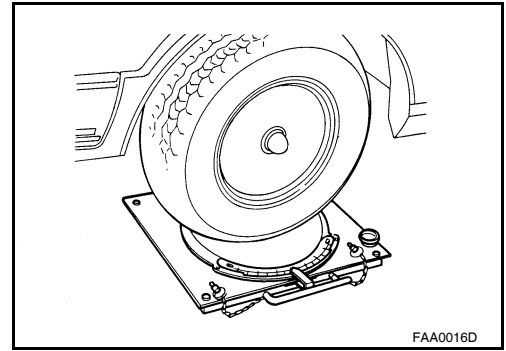

- With the engine at idle, turn steering wheel from full left stop to full right stop and measure the turning angles.

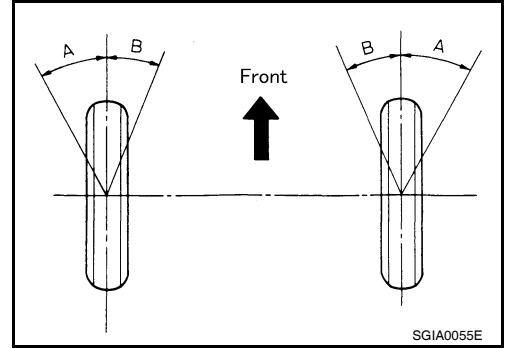

Unit: Degree Minute (Decimal Degree)

<b>Inner wheel (Angle: A)</b>	<b>Minimum</b>	<b>35° 30' (35.5°)</b>
	<b>Nominal</b>	<b>38° 30' (38.5°)</b>
	<b>Maximum</b>	<b>39° 30' (39.5°)</b>
<b>Outer wheel (Angle: B)</b>	<b>Nominal</b>	<b>31° 30' (31.5°)</b>

- Measure rack stroke if angles are outside the specified value.

<b>Rack stroke "L"</b>	<b>69 mm (2.72 in)</b>
------------------------	------------------------

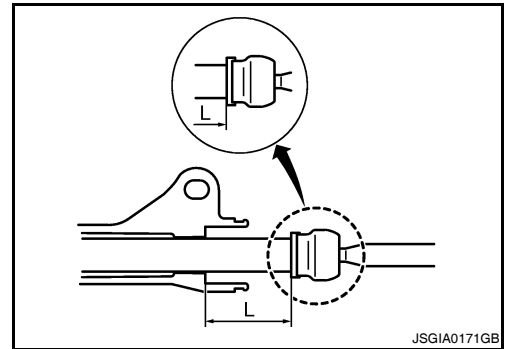

# STEERING WHEEL

< ON-VEHICLE REPAIR >

## ON-VEHICLE REPAIR

### STEERING WHEEL

#### Removal and Installation

INFOID:000000004212801

#### REMOVAL

##### NOTE:

When reconnecting spiral cable, fix cable with a tape so that fixing case and rotating part keep aligned. This will omit neutral position alignment procedure during spiral cable installation.

1. Set front wheels to straight-ahead position.
2. Remove driver air bag module. Refer to [SRS-10, "Removal and Installation"](#).
3. Remove steering wheel lock nut and washer after steering column is locked.
4. Remove steering wheel using Tool (A).

**Tool number A: ST27180001 (J-25726-A)**

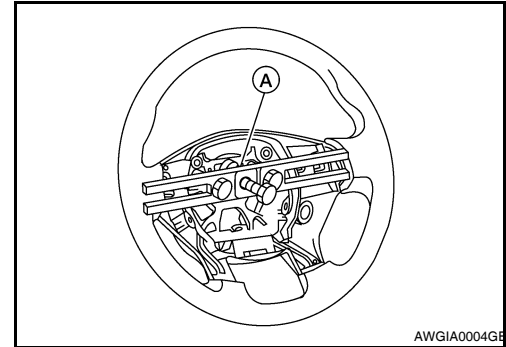

#### INSTALLATION

Installation is in the reverse order of removal.

**Steering wheel lock nut : 34.3 N·m (3.5 kg-m, 25 ft-lb)**

- As necessary, set the spiral cable neutral position.
- Slowly turn the spiral cable clockwise to the end position.
- Next, turn it counterclockwise (approximately 2 turns) then stop turning at the point when the alignment arrows (B) are directly across from each other.
- Rotate the spiral cable slightly so the locating pin (2) is positioned at the top.

##### NOTE:

A service part is installed in the neutral position with a stopper clip in place and should not be adjusted after the stopper clip is removed.

- Align the locating hole (1) at the top of the steering wheel with the locating pin (2) of the spiral cable during installation.
- Spiral cable screws (A)

##### CAUTION:

- The spiral cable may snap by steering operation if the cable is installed in an improper position.
- Do not turn the spiral cable quickly or beyond the limit number of turns. (This can cause the cable to snap.)
- After the work is completed, make sure no system malfunction is detected by air bag warning lamp.
- In case a malfunction is detected by the air bag warning lamp, reset with the self-diagnosis function and delete the memory with CONSULT-III.
- If a malfunction is still detected after the above operation, perform self-diagnosis to repair malfunctions. Refer to [SRC-7, "Driver Air Bag Module"](#).

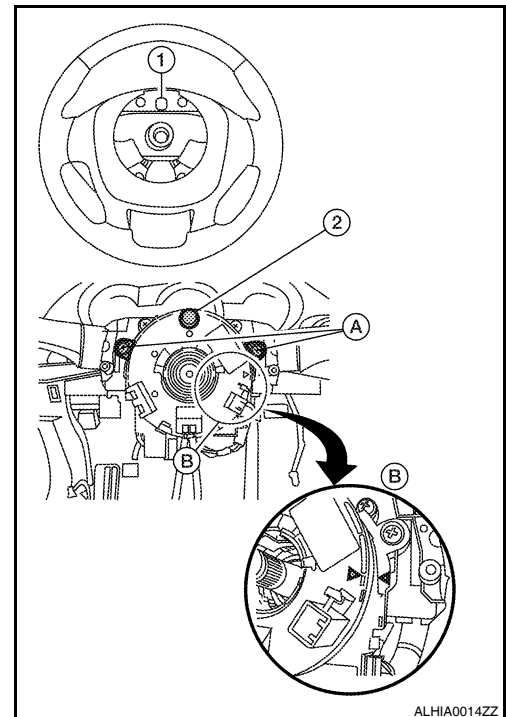



# STEERING COLUMN

< ON-VEHICLE REPAIR >

## STEERING COLUMN

### Exploded View

INFOID:000000004212802

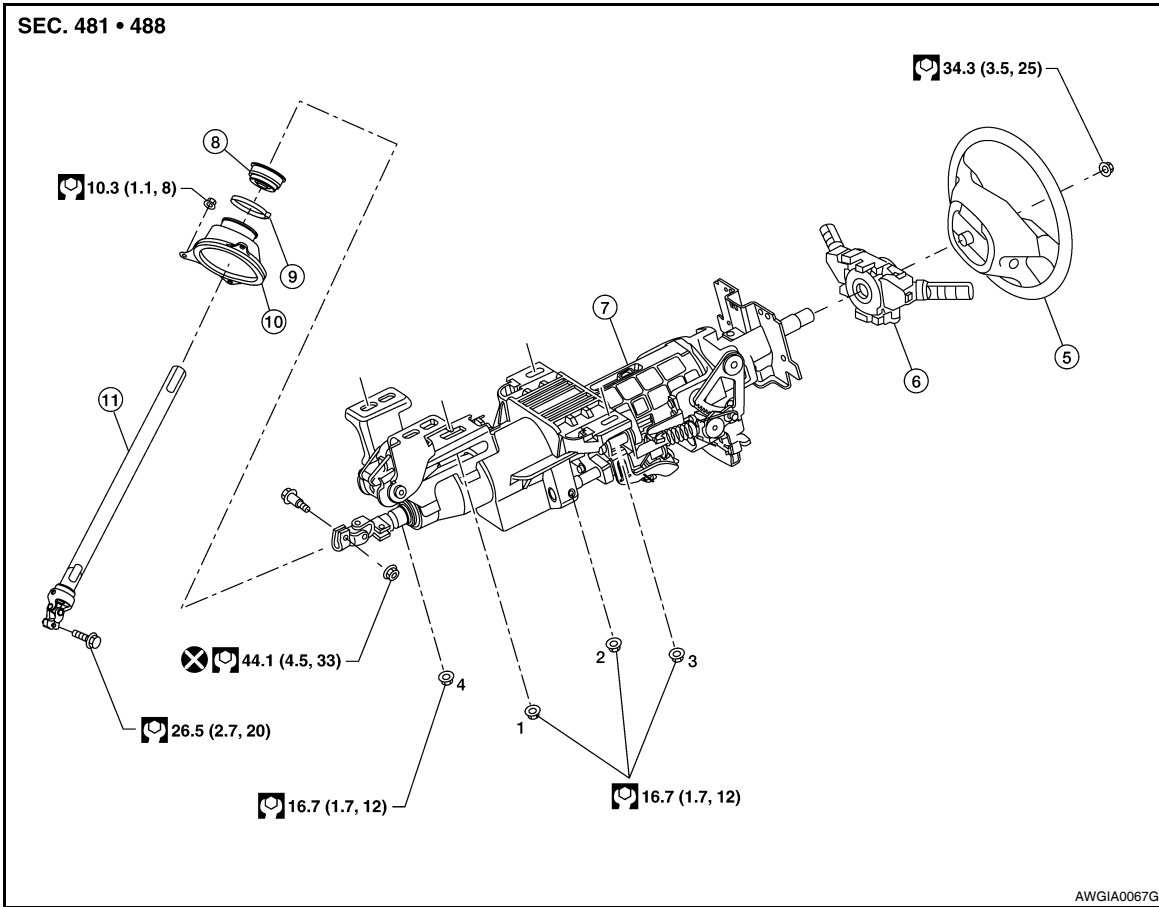

- |  |                          |  |
|--|--------------------------|--|
| 1-4. Steering column assembly nut tightening order | 5. Steering wheel        | 6. Combination switch and spiral cable |
| 7. Steering column assembly                        | 8. Hole cover seal       | 9. Herbie clip                         |
| 10. Hole cover                                     | 11. Lower shaft assembly |  |

### Removal and Installation

INFOID:000000004212803

#### REMOVAL

1. Set wheels to the straight ahead-position.
2. Remove lower side bolt of lower shaft assembly.

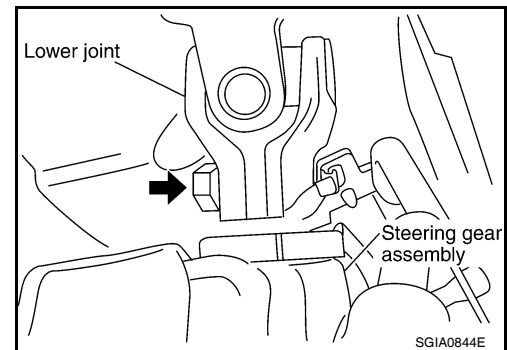

3. Remove upper side bolt of lower shaft, then remove lower shaft assembly from steering gear assembly.
4. Loosen herbie clip, then remove hole cover seal from hole cover.

# STEERING COLUMN

## < ON-VEHICLE REPAIR >

5. Remove hole cover nuts, then remove hole cover from dash panel.
6. Remove driver air bag module. Refer to [SRS-5, "Removal and Installation"](#).
7. Remove steering wheel. Refer to [ST-8, "Removal and Installation"](#).
8. Remove steering column cover and instrument driver lower panel and knee protector. Refer to [JP-12, "Removal and Installation"](#).
9. Remove spiral cable. Refer to [SRS-8, "Removal and Installation"](#).
10. Remove combination switch.
11. Disconnect harness from steering column.
12. Remove steering column nuts, then remove steering column assembly.

## INSPECTION AFTER REMOVAL

### Hole Cover Seal, Hole Cover, Lower Shaft Assembly

Check each part of hole cover seal, hole cover and steering column, lower shaft and lower joint for damage or other malfunctions. Replace if necessary.

### Steering Column Assembly

- Check each part of steering column assembly for damage or other malfunctions. Replace if necessary.
- Measure the length "L" as shown if vehicle has been involved in a minor collision. Replace steering column assembly if outside the specifications.

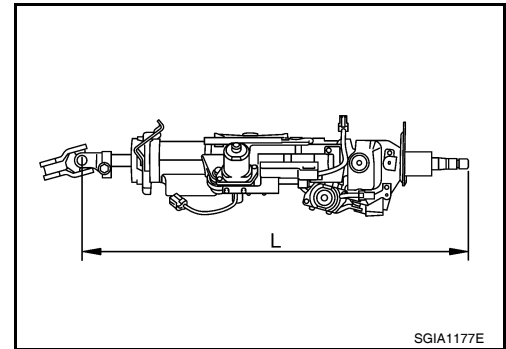

<b>Steering column length "L"</b>	<b>Telescopic maximum</b>	<b>513 - 543 mm (20.20 - 21.38 in)</b>
	<b>Telescopic minimum</b>	<b>503 - 513 mm (19.80 - 20.20 in)</b>

- Measure steering column rotating torque using Tool. Replace steering column assembly if outside the standard.

**Tool number : ST3127S000 (J-25765-A)**

**Rotating torque : 0 - 0.2 N·m (0 - 0.02 kg·m, 0 - 1 in·lb)**

- Check tilt and telescopic mechanism operating range "L<sup>1</sup>", "L<sup>2</sup>" as shown.

**Tilt operating range "L<sup>1</sup>" : 41 mm (1.61 in)**

**Telescopic operating range "L<sup>2</sup>" : 40 mm (1.57 in)**

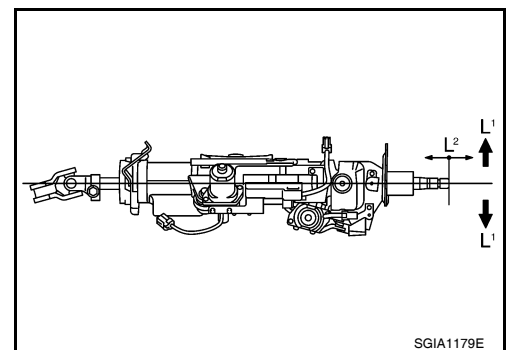

## INSTALLATION

Installation is in the reverse order of removal. For tightening specifications, refer to [ST-9, "Exploded View"](#).

- When installing lower shaft assembly to steering gear assembly, follow the procedure listed below.
- Set rack of steering gear in the neutral position.

### NOTE:

## STEERING COLUMN

### < ON-VEHICLE REPAIR >

To get the neutral position of rack, turn gear-sub assembly and measure the distance of inner socket, and then measure the intermediate position of the distance.

- Install slit part (A) of lower shaft assembly joint aligning with the marking position (B) of steering gear assembly input shaft. Make sure that the slit part of lower joint (A) is aligned with the marking position (B) of gear housing assembly input shaft.
- Perform final tightening of nuts and bolts on each part under unladen conditions with tires on level ground when removing steering gear assembly. Check wheel alignment. Refer to [FSU-6, "Inspection and Adjustment"](#).

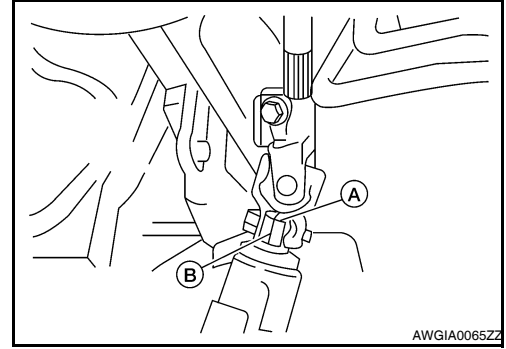

A  
B  
C  
D  
E  
F  
ST  
H  
I  
J  
K  
L  
M  
N  
O  
P

# STEERING GEAR AND LINKAGE

< ON-VEHICLE REPAIR >

## STEERING GEAR AND LINKAGE

Exploded View

INFOID:000000004212804

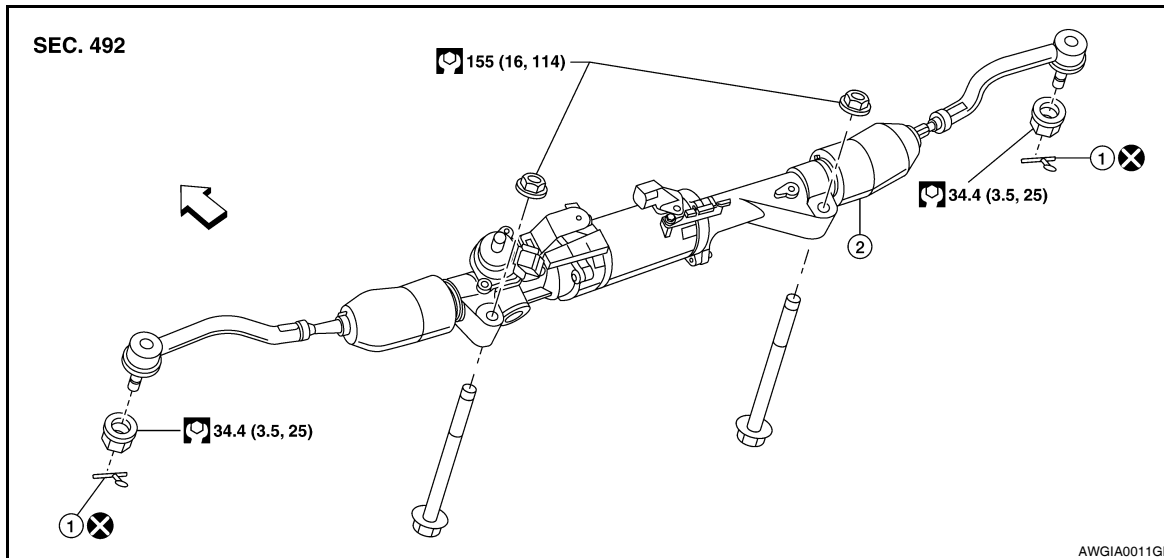

1. Cotter pin

2. Steering gear assembly

← Front

## Removal and Installation

INFOID:000000004212805

### REMOVAL

1. Remove tires using power tool. Refer to [WT-62. "Adjustment"](#).
2. Remove undercover using power tool.
3. Remove stabilizer bar connecting rods from struts and reposition stabilizer bar.
4. Remove front exhaust tube. Refer to [EX-6. "Removal and Installation"](#).
5. Remove lower side bolt of lower joint.
6. Remove cotter pin and then loosen the nut.

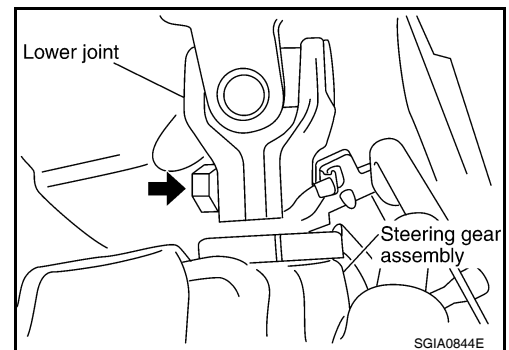

7. Remove steering outer socket from steering knuckle so as not to damage ball joint boot using Tool as shown.

**Tool number** : HT7252000 (J-25730-A)

### CAUTION:

Temporarily tighten the nut to prevent damage to threads and to prevent the Tool from suddenly coming off.

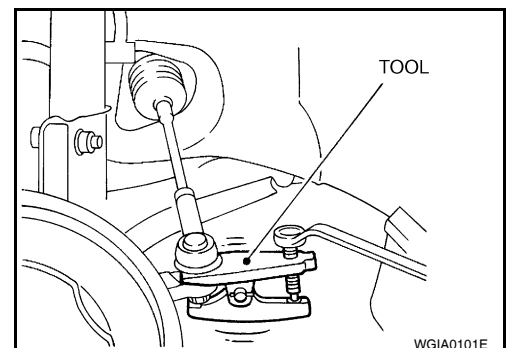

# STEERING GEAR AND LINKAGE

## < ON-VEHICLE REPAIR >

8. Disconnect EPS torque sensor harness connector (1), EPS motor angle sensor harness connector (2) and EPS motor power line connector (3) from the steering gear (4).

**NOTE:**

For EPS motor power line connector (3), perform the following;

1. Pull lock plate (5) up until it stops.
2. Turn the lock lever (6) until it stops.
3. Pull EPS motor power line connector (3) to disconnect it.

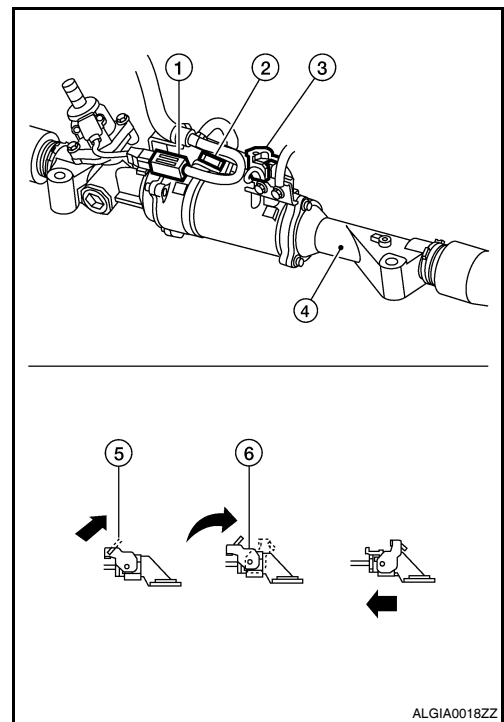

9. Remove ground bracket and harness bracket on steering gear.  
10. Remove bolts and nuts of steering gear assembly, and then remove steering gear assembly from vehicle.

### INSPECTION AFTER REMOVAL

Check for damage to steering gear. If any exist, replace steering gear as an assembly.

### INSTALLATION

Installation is the reverse order of removal. For tightening specifications, refer to [ST-12. "Exploded View"](#).

**CAUTION:**

**After connecting the EPS motor power line connector, make sure the connector is locked.**

- When installing lower joint to steering gear assembly, follow the procedure listed below.
- Set rack of steering gear in the neutral position.

**NOTE:**

To get the neutral position of rack, turn gear-sub assembly and measure the distance of inner socket, and then measure the intermediate position of the distance.

- Install slit part (A) of lower shaft assembly joint aligning with the marking position (B) of steering gear assembly input shaft. Make sure that the slit part of lower joint (A) is aligned with the marking position (B) of gear housing assembly input shaft.
- Perform final tightening of nuts and bolts on each part under unladen conditions with tires on level ground when removing steering gear assembly. Check wheel alignment. Refer to [FSU-6. "Inspection and Adjustment"](#).

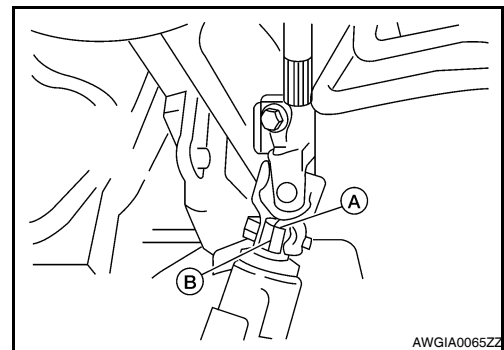

### INSPECTION AFTER INSTALLATION

Make sure that steering wheel operates smoothly by turning several times from full left stop to full right stop.

## STEERING COLUMN

< DISASSEMBLY AND ASSEMBLY >

---

### DISASSEMBLY AND ASSEMBLY

#### STEERING COLUMN

##### Disassembly and Assembly

INFOID:000000004212806

The steering column assembly is not serviceable and must be replaced as an assembly.

# STEERING GEAR AND LINKAGE

< DISASSEMBLY AND ASSEMBLY >

## STEERING GEAR AND LINKAGE

Exploded View

INFOID:000000004212807

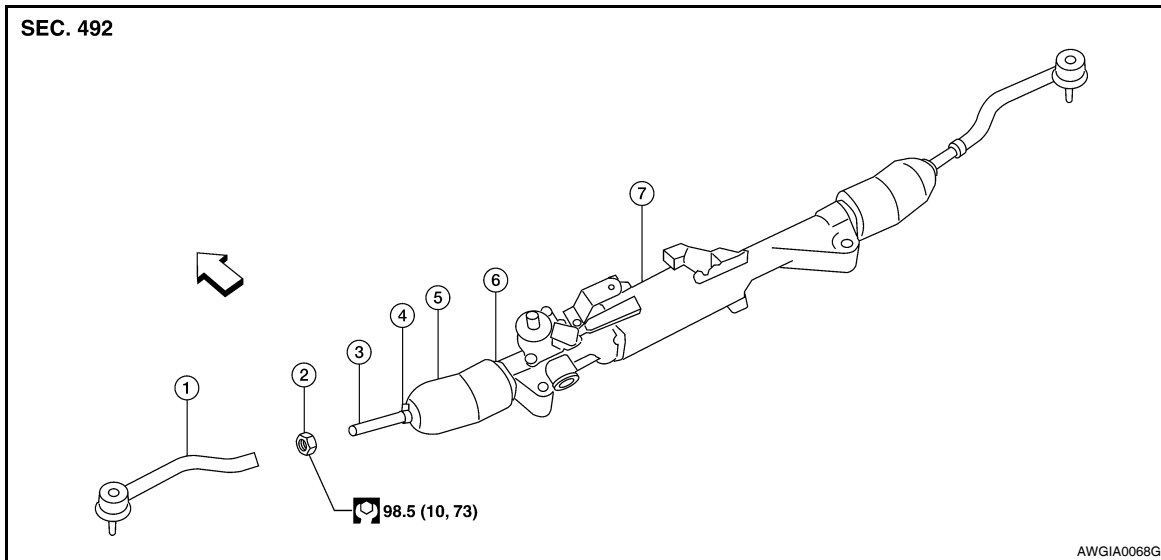

- |                     |             |                     |
|---------------------|-------------|---------------------|
| 1. Outer socket     | 2. Lock nut | 3. Inner socket     |
| 4. Small boot clamp | 5. Boot     | 6. Large boot clamp |
| 7. Gear assembly    | ← Front     |                     |

### Disassembly

INFOID:000000004212808

Remove outer socket locknut and outer socket.

**NOTE:**

Only outer socket can be disassembled. Do not disassemble steering gear assembly.

### Inspection

INFOID:000000004212809

#### INSPECTION AFTER DISASSEMBLY

##### Boot

Check the boot for cracks and replace as necessary.

##### Outer Socket and Inner Socket

- Ball joint swinging torque
  - Hook Tool (spring balance) at the hooking position (cotter pin hole) as shown. Pull on Tool (spring balance) and make sure that Tool (spring balance) reads the specified value when outer socket ball stud and inner socket (at measuring point \*) start to move. Replace outer socket and steering gear assembly (part of inner socket) if the readings are outside the standard specified value. Refer to [ST-18. "Steering Gear"](#).

**Tool number** : — (J-44372)

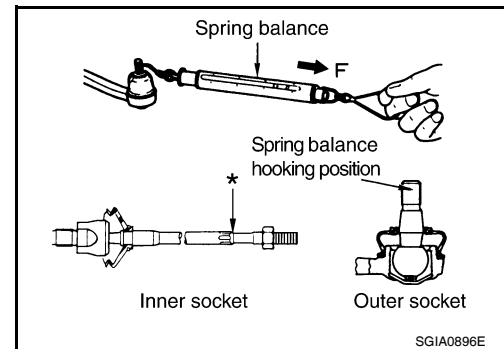

# STEERING GEAR AND LINKAGE

## < DISASSEMBLY AND ASSEMBLY >

2. Ball joint rotating torque
  - Make sure that the reading is within the following specified range using Tool as shown. Replace outer socket if the reading is outside the specified value. Refer to [ST-18. "Steering Gear"](#).

**Tool number : ST31227S000 (J-25765-A)**

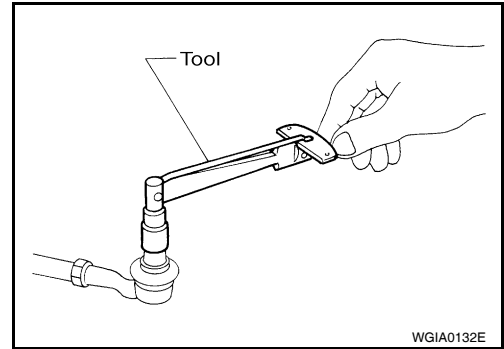

3. Ball joint axial end play
  - Apply an axial load of 490 N (50 kg-f, 111 lb-f) to ball stud. Measure amount of stud movement using a dial gauge, and then make sure that the value is within the specified range. Replace outer socket and inner socket if the measured value is outside the standard. Refer to [ST-18. "Steering Gear"](#).

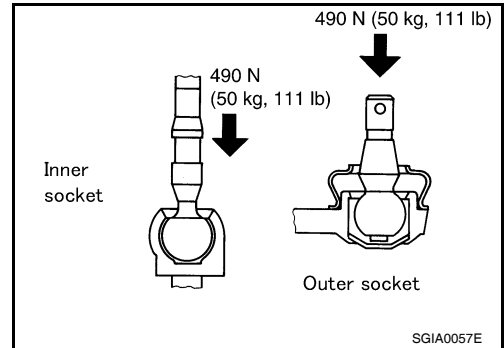

INFOID:000000004212810

## Assembly

Assembly is in the reverse order of disassembly.

- Adjust inner socket to standard length (L), and then tighten lock nut to the specified torque. Refer to [ST-15. "Exploded View"](#). Check length of inner socket (L) again after tightening lock nut. Make sure that the length is the standard.

<b>Inner socket length (L), Standard</b>	<b>: 43.9 mm (1.728 in)</b>
<b>Inner socket length (L), Maximum</b>	<b>: 48.9 mm (1.925 in)</b>

### CAUTION:

**Adjust toe-in after assembly. Inner socket length achieved after toe-in adjustment should not exceed the maximum specification.**

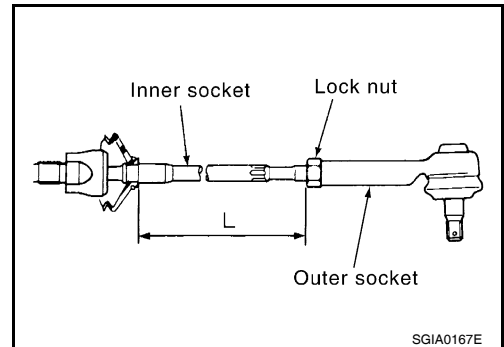



# SERVICE DATA AND SPECIFICATIONS (SDS)

< SERVICE DATA AND SPECIFICATIONS (SDS)

## SERVICE DATA AND SPECIFICATIONS (SDS)

### SERVICE DATA AND SPECIFICATIONS (SDS)

#### Steering Wheel

INFOID:000000004212811

Steering wheel axial end play	0 mm (0 in)
Steering wheel play	0 - 35 mm (0 - 1.38 in)
Steering wheel turning force	39 N (4 kg-f, 9 lb-f) or less

#### Steering Angle

INFOID:000000004212812

Unit: degree minute (decimal degree)

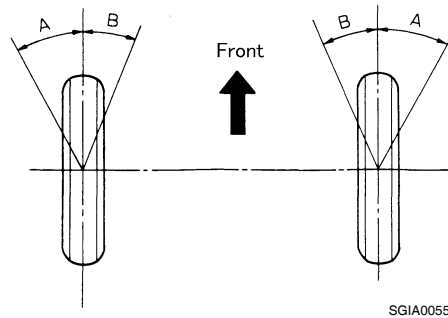

Inner wheel (Angle: A)	Minimum	35° 30' (35.5°)
	Nominal	38° 30' (38.5°)
	Maximum	39° 30' (39.5°)
Outer wheel (Angle: B)	Nominal	31° (31.5°)

#### Steering Column

INFOID:000000004212813

#### STEERING COLUMN LENGTH

Unit: mm (in)

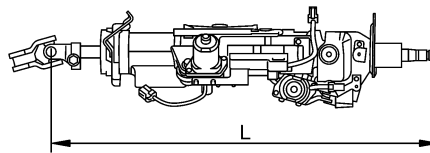

Steering column length (L)	Telescopic maximum	513 - 543 (20.20 - 21.38)
	Telescopic minimum	503 - 513 (19.80 - 20.20)

#### STEERING COLUMN ROTATING TORQUE

Unit: N·m (kg-m, in-lb)

Steering column rotating torque	0 - 0.2 (0 - 0.2, 0 - 1)
---------------------------------	--------------------------

#### TILT MECHANISM OPERATING RANGE

# SERVICE DATA AND SPECIFICATIONS (SDS)

## < SERVICE DATA AND SPECIFICATIONS (SDS)

Unit: mm (in)

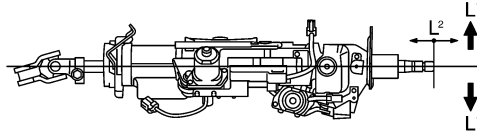

SGIA1179E

Tilt operating range (L <sup>1</sup> )	41 (1.61)
Telescopic operating range (L <sup>2</sup> )	40 (1.57)

## Steering Gear

INFOID:000000004212814

### STEERING OUTER SOCKET AND INNER SOCKET

Steering gear type		PR26AF
Outer socket	Swinging torque	0.1 - 2.9 N·m (0.01 - 0.29 kg-m, 1.0 - 25 in-lb)
	Measurement on spring balance Measuring point: cotter pin hole of stud	1.4 - 42.7 N (0.14 - 4.4 kg, 0.31 - 9.7 lb)
	Rotating torque	0.3 - 2.9 N·m (0.03 - 0.29 kg-m, 3.0 - 25 in-lb)
	Axial end play	0.5 mm (0.020 in) or less
Inner socket	Swinging torque	0.1 - 7.8 N·m (0.01 - 0.79 kg-m, 1.0 - 69 in-lb)
	• Measurement on spring balance • Measuring point at* mark shown	0.8 - 64 N (0.082 - 6.5 kg, 0.18 - 14.4 lb)
	Axial end play	0.2 mm (0.008 in) or less
Inner socket length (L)	Standard	43.9 mm (1.728 in)
	Maximum	48.9 mm (1.925 in)

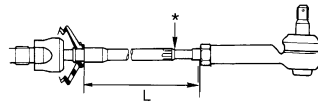

SGIA0950E

## RACK STROKE

# SERVICE DATA AND SPECIFICATIONS (SDS)

## < SERVICE DATA AND SPECIFICATIONS (SDS)

Unit: mm (in)

Steering gear model	PR26AF
Rack neutral position, dimension "L" (rack stroke)	69 (2.72)

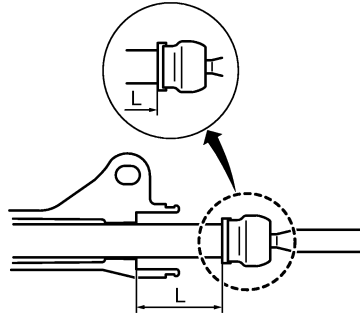

JSGIA0171GB

A  
B  
C  
D  
E  
F  
ST  
H  
I  
J  
K  
L  
M  
N  
O  
P