

SECTION **FSU**
FRONT SUSPENSION

A
B
C
D
E
F
G
H
I
J
K
L
M
N
O
P

FSU

CONTENTS

SYMPTOM DIAGNOSIS	2	FRONT COIL SPRING AND STRUT	9	F
NOISE, VIBRATION AND HARSHNESS (NVH) TROUBLESHOOTING	2	Removal and Installation	9	
NVH Troubleshooting Chart	2	TRANSVERSE LINK	10	G
PRECAUTION	3	Removal and Installation	10	
PRECAUTIONS	3	FRONT STABILIZER	11	H
Precaution for Supplemental Restraint System (SRS) "AIR BAG" and "SEAT BELT PRE-TENSIONER"	3	Removal and Installation	11	
Necessary for Steering Wheel Rotation After Battery Disconnect	3	REMOVAL AND INSTALLATION	12	I
Service Notice or Precautions	3	FRONT SUSPENSION ASSEMBLY	12	J
PREPARATION	5	Exploded View	12	
PREPARATION	5	Removal and Installation	13	K
Special Service Tool	5	DISASSEMBLY AND ASSEMBLY	14	L
Commercial Service Tool	6	FRONT COIL SPRING AND STRUT	14	
ON-VEHICLE MAINTENANCE	7	Disassembly and Assembly	14	M
FRONT SUSPENSION ASSEMBLY	7	Inspection	15	
Inspection and Adjustment	7	SERVICE DATA AND SPECIFICATIONS (SDS)	16	N
ON-VEHICLE REPAIR	9	SERVICE DATA AND SPECIFICATIONS (SDS)	16	O
		Wheel Alignment (Unladen*)	16	
		Ball Joint	17	P
		Wheelarch Height (Unladen*1)	17	

NOISE, VIBRATION AND HARSHNESS (NVH) TROUBLESHOOTING

< SYMPTOM DIAGNOSIS >

SYMPTOM DIAGNOSIS

NOISE, VIBRATION AND HARSHNESS (NVH) TROUBLESHOOTING

NVH Troubleshooting Chart

INFOID:000000004205262

Use the chart below to help you find the cause of the symptom. If necessary, repair or replace these parts.

Reference page		FSU-12	FSU-15	—	—	—	FSU-12	FSU-7	FSU-7	WT-61, "NVH Troubleshooting Chart"	WT-61, "NVH Troubleshooting Chart"	FAX-2, "NVH Troubleshooting Chart"	BR-6, "NVH Troubleshooting Chart"	ST-3, "NVH Troubleshooting Chart"
Possible cause and SUSPECTED PARTS		Improper installation, looseness	Shock absorber deformation, damage or deflection	Bushing or mounting deterioration	Parts interference	Spring fatigue	Suspension looseness	Incorrect wheel alignment	Stabilizer bar fatigue	TIRES	ROAD WHEEL	DRIVE SHAFT AND WHEEL HUB	BRAKES	STEERING
Symptom	Noise	x	x	x	x	x	x			x	x	x	x	x
	Shake	x	x	x	x		x			x	x	x	x	x
	Vibration	x	x	x	x	x				x		x		x
	Shimmy	x	x	x	x			x		x	x		x	x
	Shudder	x	x	x						x	x		x	x
	Poor quality ride or handling	x	x	x	x	x		x	x	x	x			

x: Applicable

PRECAUTIONS

< PRECAUTION >

PRECAUTION

PRECAUTIONS

Precaution for Supplemental Restraint System (SRS) "AIR BAG" and "SEAT BELT PRE-TENSIONER"

INFOID:000000004205263

The Supplemental Restraint System such as "AIR BAG" and "SEAT BELT PRE-TENSIONER", used along with a front seat belt, helps to reduce the risk or severity of injury to the driver and front passenger for certain types of collision. This system includes seat belt switch inputs and dual stage front air bag modules. The SRS system uses the seat belt switches to determine the front air bag deployment, and may only deploy one front air bag, depending on the severity of a collision and whether the front occupants are belted or unbelted. Information necessary to service the system safely is included in the SR and SB section of this Service Manual.

WARNING:

- To avoid rendering the SRS inoperative, which could increase the risk of personal injury or death in the event of a collision which would result in air bag inflation, all maintenance must be performed by an authorized NISSAN/INFINITI dealer.
- Improper maintenance, including incorrect removal and installation of the SRS, can lead to personal injury caused by unintentional activation of the system. For removal of Spiral Cable and Air Bag Module, see the SR section.
- Do not use electrical test equipment on any circuit related to the SRS unless instructed to in this Service Manual. SRS wiring harnesses can be identified by yellow and/or orange harnesses or harness connectors.

Necessary for Steering Wheel Rotation After Battery Disconnect

INFOID:000000004501328

NOTE:

- Before removing and installing any control units, first turn the push-button ignition switch to the LOCK position, then disconnect both battery cables.
- After finishing work, confirm that all control unit connectors are connected properly, then re-connect both battery cables.
- Always use CONSULT-III to perform self-diagnosis as a part of each function inspection after finishing work. If a DTC is detected, perform trouble diagnosis according to self-diagnosis results.

This vehicle is equipped with a push-button ignition switch and a steering lock unit.

If the battery is disconnected or discharged, the steering wheel will lock and cannot be turned.

If turning the steering wheel is required with the battery disconnected or discharged, follow the procedure below before starting the repair operation.

OPERATION PROCEDURE

1. Connect both battery cables.

NOTE:

Supply power using jumper cables if battery is discharged.

2. Carry the Intelligent Key or insert it to the key slot and turn the push-button ignition switch to ACC position. (At this time, the steering lock will be released.)
3. Disconnect both battery cables. The steering lock will remain released with both battery cables disconnected and the steering wheel can be turned.
4. Perform the necessary repair operation.
5. When the repair work is completed, re-connect both battery cables. With the brake pedal released, turn the push-button ignition switch from ACC position to ON position, then to LOCK position. (The steering wheel will lock when the push-button ignition switch is turned to LOCK position.)
6. Perform self-diagnosis check of all control units using CONSULT-III.

Service Notice or Precautions

INFOID:000000004205264

- When installing rubber bushings, the final tightening must be carried out under unladen conditions with tires on ground. Oil might shorten the life of rubber bushings. Be sure to wipe off any spilled oil.
- Unladen conditions mean that fuel, engine coolant and lubricant are full. Spare tire, jack, hand tools and mats are in designated positions.
- After servicing suspension parts, be sure to check wheel alignment.

PRECAUTIONS

< PRECAUTION >

- Self-lock nuts are not reusable. Always use new ones when installing. Since new self-lock nuts are pre-oiled, tighten as they are.

PREPARATION

< PREPARATION >

PREPARATION

PREPARATION

Special Service Tool

INFOID:000000004205265

The actual shapes of the Kent-Moore tools may differ from those of special service tools illustrated here.

Tool number (Kent-Moore No.) Tool name	Description
HT7252000 (J-25730-A) Ball joint remover	Removing tie-rod outer and lower ball joint
ST3127S000 (J-25765-A) Preload gauge	Measuring ball joint rotating torque
KV991040S1 (—) CCK gauge attachment <ol style="list-style-type: none"> 1. KV99104020 Adapter A 2. KV99104030 Adapter B 3. KV99104040 Adapter C 4. KV99104050 Adapter D 5. KV99104060 Plate 6. KV99104070 Guide bolt 7. KV99104080 Spring 8. KV99104090 Center plate 	Measuring wheel alignment
ST35652000 (—) Strut attachment	Disassembling and assembling strut
KV101J0010 (J-47242) Engine support table	Front suspension member removal

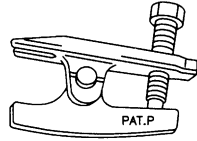

S-NT146

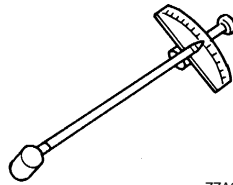

ZZA0806D

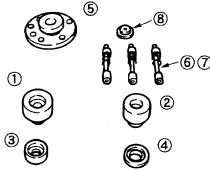

ZZA1167D

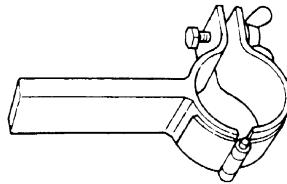

ZZA0807D

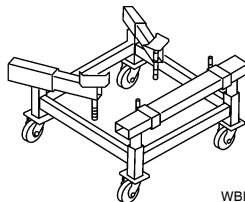

WBIA0658E



A
B
C
D
FSU
F
G
H
I
J
K
L
M
N
O
P

PREPARATION

< PREPARATION >

Commercial Service Tool

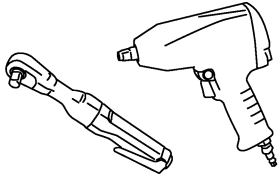
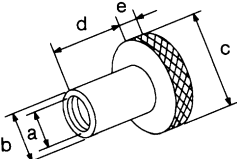
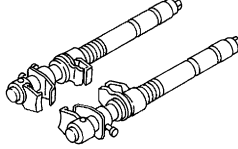
INFOID:000000004205266

Tool name	Description
<p>Power tool</p>  <p>PBIC0190E</p>	<p>Loosening bolts and nuts</p>
<p>Attachment wheel alignment a: screw M24 x 1.5 pitch b: 35 mm (1.38 in) dia. c: 65 mm (2.56 in) dia. d: 56 mm (2.20 in) dia. e: 12 mm (0.47 in) dia.</p>  <p>NT148</p>	<p>Measure wheel alignment</p>
<p>Spring compressor</p>  <p>NT717</p>	<p>Removing and installing coil spring</p>
<p>Engine slinger</p>  <p>LEIA0062E</p>	<p>Removing and installing suspension member with VQ35DE and CVT</p>

FRONT SUSPENSION ASSEMBLY

< ON-VEHICLE MAINTENANCE >

ON-VEHICLE MAINTENANCE

FRONT SUSPENSION ASSEMBLY

Inspection and Adjustment

INFOID:000000004205267

INSPECTION

Make sure the mounting conditions (looseness, back lash) of each component and component conditions (wear, damage) are normal.

LOWER BALL JOINT END PLAY

1. Set front wheels in a straight-ahead position. Do not depress brake pedal.
2. Place an iron bar or similar tool between upper link and steering knuckle.
3. Measure axial end play by prying it up and down. Refer to [FSU-17, "Ball Joint"](#).

CAUTION:

Be careful not to damage ball joint boot. Do not damage the installation position by applying excessive force.

SHOCK ABSORBER

Check for oil leakage, damage and replace if malfunction is detected.

WHEEL ALIGNMENT

Description

Measure wheel alignment under unladen conditions.

NOTE:

"Unladen conditions" means that fuel, engine coolant, and lubricant are full. Spare tire, jack, hand tools and mats are in designated positions.

General Information and Recommendations

- A four-wheel thrust alignment should be performed.
- This type of alignment is recommended for any NISSAN vehicle.
- The four-wheel "thrust" process helps ensure that the vehicle is properly aligned and the steering wheel is centered.
- The alignment rack itself should be capable of accepting any NISSAN vehicle.
- The rack should be checked to ensure that it is level.
- Make sure the machine is properly calibrated.
- Your alignment equipment should be regularly calibrated in order to give correct information.
- Check with the manufacturer of your specific equipment for their recommended Service/Calibration Schedule.

Preliminary Check

Check the following:

1. Tires for improper air pressure and wear.
2. Road wheels for runout. Refer to [WT-70, "Road Wheel"](#).
3. Wheel bearing axial end play. Refer to [FAX-27, "Wheel Bearing"](#).
4. Transverse link ball joint axial end play. Refer to [FSU-10, "Removal and Installation"](#).
5. Shock absorber operation.
6. Each mounting part of axle and suspension for looseness and deformation.
7. Each of suspension member, shock absorber, upper link and transverse link for cracks, deformation and other damage.
8. Vehicle height (posture).

Alignment Process

IMPORTANT:

Use only the alignment specifications listed in this Service Manual.

- When displaying the alignment settings, many alignment machines use "indicators" **Do not use these indicators.**: (Green/red, plus or minus, Go/No Go).
- The alignment specifications programmed into your machine that operate these indicators may not be correct.

FRONT SUSPENSION ASSEMBLY

< ON-VEHICLE MAINTENANCE >

- This may result in an ERROR.
- Some newer alignment machines are equipped with an optional "Rolling Compensation" method to "compensate" the sensors (alignment targets or head units). Do not use this "Rolling Compensation" method.
- Use the "Jacking Compensation Method". After installing the alignment targets or head units, raise the vehicle and rotate the wheels 1/2 turn both ways.
- See Instructions in the alignment machine you're using for more information on this.

ADJUSTMENT

Camber, Caster and Kingpin Inclination Angles

CAUTION:

Camber, caster, kingpin inclination angles cannot be adjusted.

FRONT COIL SPRING AND STRUT

< ON-VEHICLE REPAIR >

ON-VEHICLE REPAIR

FRONT COIL SPRING AND STRUT

Removal and Installation

INFOID:000000004205268

REMOVAL

1. Remove wheel and tire. Refer to [WT-66. "Adjustment"](#).
2. Remove brake caliper and reposition aside using wire. Refer to [BR-30. "BRAKE CALIPER ASSEMBLY : Exploded View"](#).
CAUTION:
Avoid depressing brake pedal with brake caliper removed.
3. Remove wheel sensor electrical harness from strut. Refer to [BRC-63. "Removal and Installation"](#) (ABS), [BRC-134. "Removal and Installation"](#) (TCS/ABS), [BRC-236. "Removal and Installation"](#) (VDC/TCS/ABS).
4. Remove brake hose lock plate.
5. Remove steering knuckle to strut bolts and nuts. Refer to [FSU-12. "Exploded View"](#).
6. Remove bolt on strut tower bar then bolts on strut tower and remove strut from vehicle.

INSPECTION AFTER REMOVAL

Check the strut for any oil leakage or other damage and replace as necessary.

INSTALLATION

Installation is in the reverse order of removal.

- Refer to [FSU-12. "Exploded View"](#) for tightening torque.
- Be sure arrows on strut mount insulator and spring upper seat are positioned as shown. Also be sure notch in strut spacer is positioned as shown. Then install strut.
- Assemble upper mounting plate with its notch facing toward the outside.

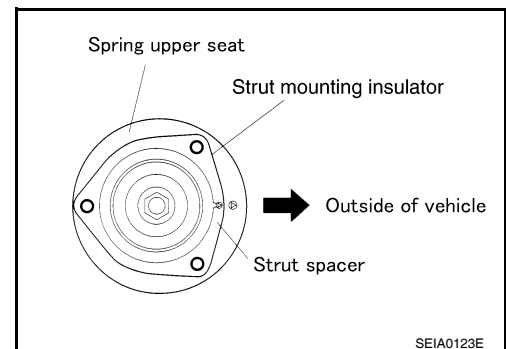

TRANSVERSE LINK

< ON-VEHICLE REPAIR >

TRANSVERSE LINK

Removal and Installation

INFOID:000000004205269

REMOVAL

1. Remove wheel and tire. Refer to [WT-66, "Adjustment"](#).
2. Remove steering knuckle from transverse link. Refer to [FSU-12, "Exploded View"](#).
3. Remove mounting nuts and washers on lower portion of stabilizer connecting rod.
4. Slightly loosen transverse link mounting bolts.
5. Remove transverse link bolts and nuts, and remove transverse link from suspension member.

INSPECTION AFTER REMOVAL

Visual Inspection

Check transverse link and bushing for deformation, cracks, and other damage. Replace the entire transverse link assembly if cracks, deformation or any other damage is found.

Ball Joint Inspection

CAUTION:

Before measurement, move the ball joint at least ten times by hand to check for smooth movement.

Swing Torque Inspection

- Hook spring scale at cotter pin mounting hole. Confirm spring scale measurement value is within specifications when ball stud begins moving.

Swing force:

0.50 - 3.4 N·m (0.06 - 0.34 kg·m, 5 - 30 in-lb)

Measurement on spring balance:

7.94 - 53.97 N (0.81 - 5.50 kg, 1.79 - 12.2 lb)

- If the value is outside the standard, replace transverse link.

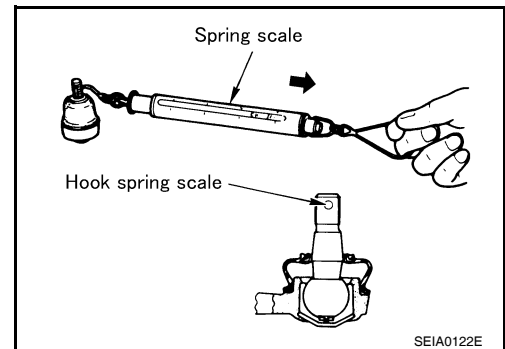

Rotating Torque Inspection

- Attach nut to ball stud. Check that rotating torque is within specifications using Tool.

Tool number : ST3127S000 (J-25765-A)

Rotating torque:

0.50 - 3.4 N·m (0.06 - 0.34 kg·m, 5 - 30 in-lb)

- If the value is outside the standard, replace transverse link.

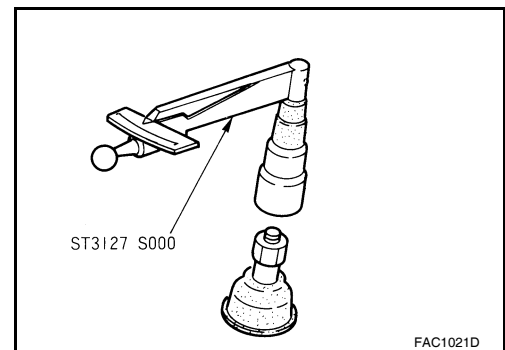

Axial Endplay Inspection

- Move tip of ball joint in axial direction to check for looseness.

Axial endplay : 0.1 mm (0.004 in) or less

- If any looseness is noted, replace transverse link.

INSTALLATION

Installation is in the reverse order of removal.

- Refer to [FSU-12, "Exploded View"](#) for tightening torque.
- Tighten transverse link bolts with vehicle unladen and all four tires on flat, level ground.
- After installation, check wheel alignment. Refer to [FSU-7, "Inspection and Adjustment"](#).

FRONT STABILIZER

< ON-VEHICLE REPAIR >

FRONT STABILIZER

Removal and Installation

INFOID:000000004205270

REMOVAL

1. Remove steering gear. Refer to [ST-17, "Removal and Installation"](#).
2. Remove mounting nuts on upper portion of stabilizer connecting rod.

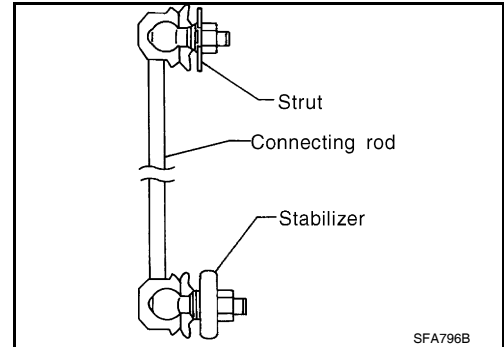

3. Remove stabilizer clamp bolts.
4. Remove stabilizer from the vehicle.

INSPECTION AFTER REMOVAL

Check stabilizer, connecting rod, bushing and clamp for deformation, cracks and damage, and replace if necessary.

INSTALLATION

Installation is in the reverse order of removal.

- Refer to [FSU-12, "Exploded View"](#) for tightening torque.
- When installing stabilizer, make sure that the clamps are facing in the direction shown.
- Make sure the cut surface of the bushing faces the rear.

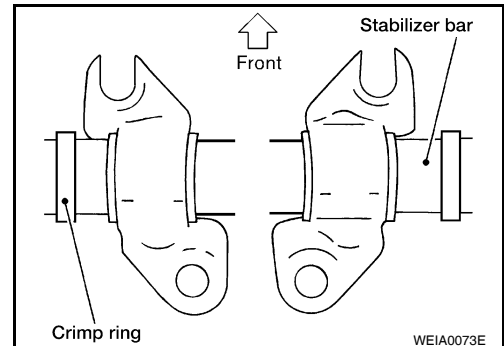

- Stabilizer uses pillow ball type connecting rod. Position ball joint with case on pillow ball head parallel to stabilizer.

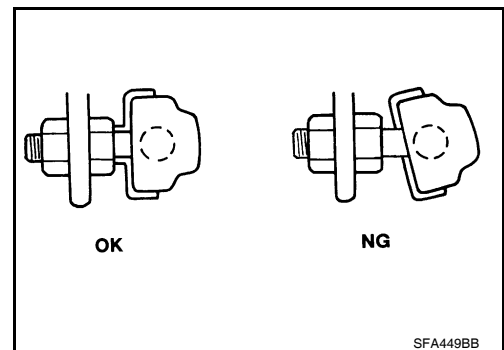

FRONT SUSPENSION ASSEMBLY

< REMOVAL AND INSTALLATION >

REMOVAL AND INSTALLATION

FRONT SUSPENSION ASSEMBLY

Exploded View

INFOID:000000004205271

SEC. 400 • 401 • 406

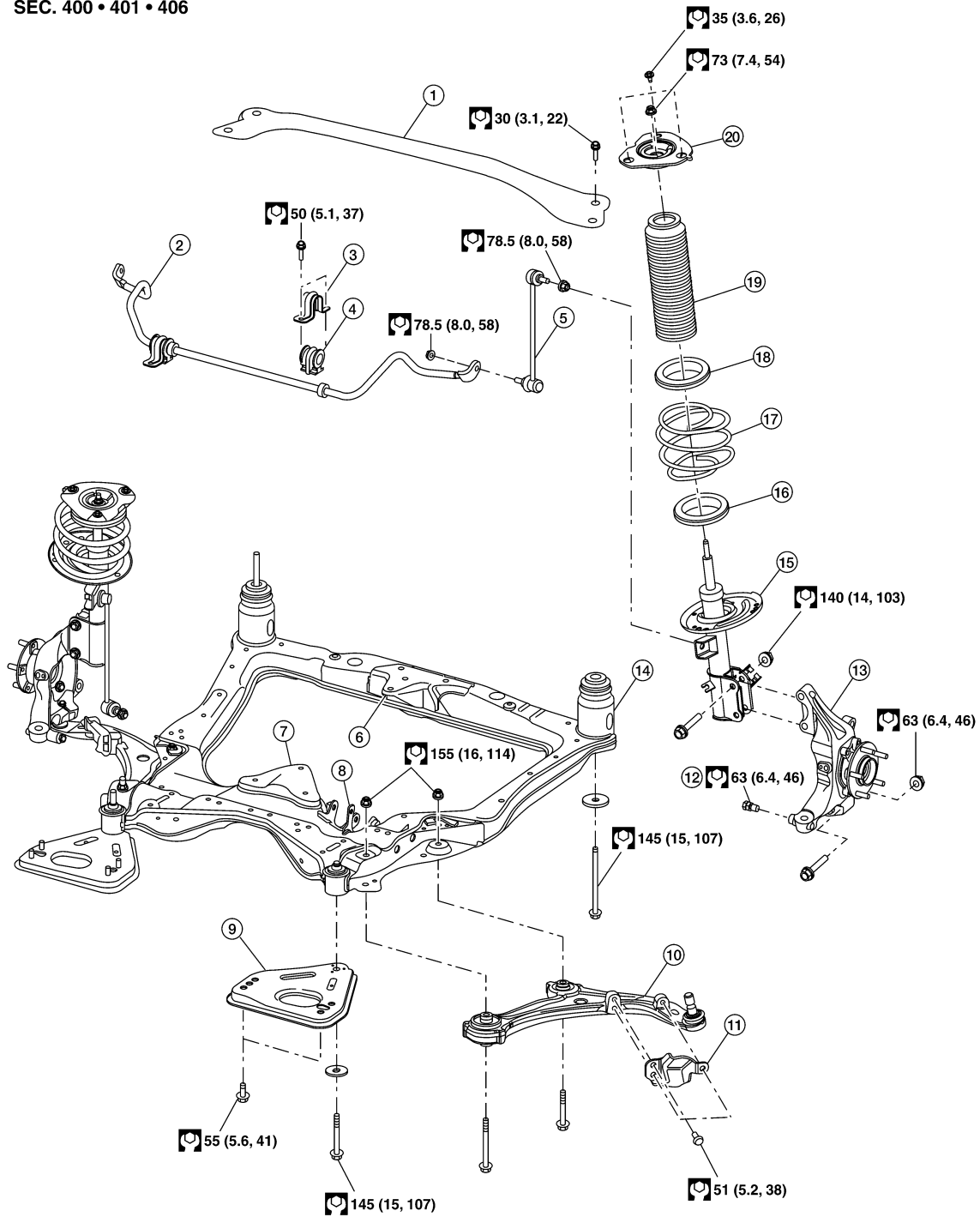

ALEIA0045GB

FRONT SUSPENSION ASSEMBLY

< REMOVAL AND INSTALLATION >

- | | | | |
|------------------------------|-----------------------------|-------------------------------|---|
| 1. Strut tower bar | 2. Stabilizer bar | 3. Stabilizer clamp | A |
| 4. Stabilizer bushing | 5. Connecting rod | 6. VQ35DE front mount bracket | |
| 7. VQ35DE rear mount bracket | 8. QR25DE mount bracket | 9. Member pin stay | |
| 10. Transverse link | 11. Steering stop plate | 12. Steering stop | B |
| 13. Steering knuckle | 14. Front suspension member | 15. Strut | |
| 16. Lower rubber seat | 17. Coil spring | 18. Upper rubber seat | |
| 19. Dust cover | 20. Strut mount insulator | | C |

Removal and Installation

INFOID:000000004205272

REMOVAL

QR25DE Engine and VQ35DE Engine with M/T

1. Remove wheel and tire. Refer to [WT-66, "Adjustment"](#).
2. Remove engine under cover. Refer to [EXT-13, "Removal and Installation"](#) (Coupe), [EXT-34, "Removal and Installation"](#) (Sedan).
3. Remove nut on lower portion of stabilizer connecting rod from transverse link.
4. Remove transverse link from suspension member, and move the transverse link outward.
5. Remove front exhaust tube. Refer to [EX-6, "Removal and Installation"](#) (QR25DE), [EX-12, "Removal and Installation"](#) (VQ35DE).
6. Support engine or transmission with a jack.
7. Remove steering gear bolts. Remove steering gear and power steering tube bracket from suspension member.
8. Hang steering gear.
9. Remove front and rear engine mount insulator bolts from suspension member.
10. Remove body-side bolts from member pin stay.
11. Set a jack under suspension member, and remove suspension member nuts.
12. Slowly lower jack to remove suspension member from vehicle.

VQ35DE Engine with CVT

Engine, transmission and suspension member must be removed as an assembly. Refer to [EM-202, "Removal and Installation"](#).
Once removed as an assembly, lift engine and transmission off of suspension member.

INSTALLATION

Installation is in the reverse order of removal.

- Refer to [FSU-12, "Exploded View"](#) for tightening torque.
- After installation, perform final tightening of each part under unladen conditions with tires on ground. Check wheel alignment. Refer to [FSU-7, "Inspection and Adjustment"](#).

FSU

FRONT COIL SPRING AND STRUT

< DISASSEMBLY AND ASSEMBLY >

DISASSEMBLY AND ASSEMBLY

FRONT COIL SPRING AND STRUT

Disassembly and Assembly

INFOID:000000004205273

DISASSEMBLY

1. Install Tool to strut and secure it in a vise.

Tool number : ST35652000 (—)

CAUTION:

When installing Tool, wrap a shop cloth around strut to protect it from damage.

2. Slightly loosen piston rod lock nut.

WARNING:

Do not remove piston rod lock nut completely. If it is removed completely, the coil spring can jump out and may cause serious damage or injury.

3. Compress coil spring using a commercially available spring compressor.

WARNING:

Make sure that the pawls of the two spring compressors are firmly hooked on the spring. The spring compressors must be tightened alternately so as not to tilt the spring.

4. Making sure coil spring is free between upper and lower seats, then remove piston rod lock nut.
5. Remove small parts on strut.
 - Remove strut spacer, strut mount insulator, strut mounting insulator bracket thrust bearing, spring upper seat, and upper rubber seat. Then remove coil spring.
6. Remove bound bumper from spring upper seat.
7. Gradually release spring compressor (commercial service tool), and remove coil spring.

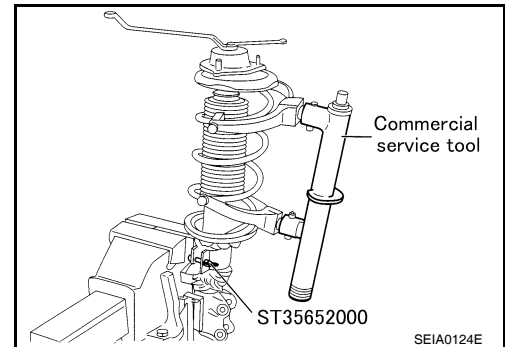

ASSEMBLY

1. Compress coil spring using a spring compressor (commercial service tool), and install it onto the strut.

CAUTION:

Face tube side of coil spring downward. Align lower end to spring seat as shown.

WARNING:

Be sure spring compressor is securely attached to coil spring. Compress coil spring.

2. Connect bound bumper to spring upper seat.

CAUTION:

• Be sure to install bound bumper to spring upper seat securely.

• When installing bound bumper, use soapy water. Do not use machine oil or other lubricants.

3. Install small parts to the strut.

• Connect upper rubber seat, spring upper seats, thrust bearing, strut mount insulator, and strut spacer. Temporarily install piston rod lock nut.

CAUTION:

Do not reuse piston rod lock nut.

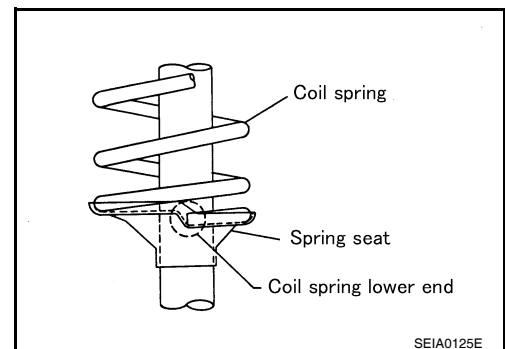

FRONT COIL SPRING AND STRUT

< DISASSEMBLY AND ASSEMBLY >

4. Be sure arrows on strut mount insulator and spring upper seat are positioned as shown. Also be sure notch in the strut spacer is positioned as shown.
5. Be sure coil spring is properly set in spring rubber seat. Gradually release spring compressor.
CAUTION:
Be sure upper rubber seat is properly aligned to spring upper seat and coil spring.
6. Tighten piston rod lock nut to the specified torque.

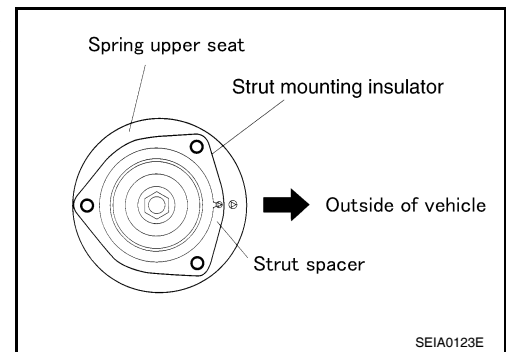

7. Remove Tool from strut.

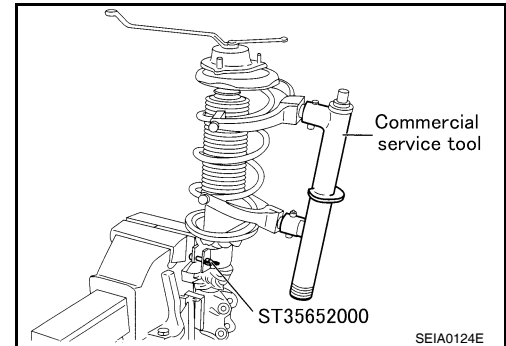

Inspection

INSPECTION AFTER DISASSEMBLY

Strut

- Check strut for deformation, cracks, and damage, and replace if necessary.
- Check piston rod for damage, uneven wear, and distortion, and replace if necessary.
- Check welded and sealed areas for oil leakage, and replace if necessary.

Insulator and Rubber Parts

Check strut mount insulator for cracks and rubber parts for wear. Replace them if necessary.

Coil Spring

Check for cracks, wear, and damage, and replace if necessary.

INFOID:000000004205274

SERVICE DATA AND SPECIFICATIONS (SDS)

< SERVICE DATA AND SPECIFICATIONS (SDS)

SERVICE DATA AND SPECIFICATIONS (SDS)

SERVICE DATA AND SPECIFICATIONS (SDS)

Wheel Alignment (Unladen*)

INFOID:000000004205275

SEDAN

Market			USA/Canada		Mexico	
Engine type			QR25DE and VQ35DE		QR25DE and VQ35DE	
Tire size			215/60R16	215/55R17	215/60R16	215/55R17
Camber Degree minute (Decimal degree)	LH	Minimum	-1°15' (-1.25°)		-1°09' (-1.15°)	
		Nominal	-0°30' (-0.50°)		-0°24' (-0.40°)	
		Maximum	0°15' (0.25°)		0°21' (0.35°)	
	RH	Minimum	-1°30' (-1.50°)		-1°24' (-1.40°)	
		Nominal	-0°45' (-0.75°)		-0°39' (-0.65°)	
		Maximum	0°00' (0.00°)		-0°06' (-0.10°)	
	Left and right difference		-0°15' ± 0° 33' (-0.25° ± 0.55°)			
Caster Degree minute (Decimal degree)	Minimum		4°09' (4.15°)		3°54' (3.90°)	
	Nominal		4°54' (4.90°)		4°39' (4.65°)	
	Maximum		5°39' (5.65°)		5°24' (5.40°)	
	Left and right difference		± 0° 33' (± 0.55°)			
Kingpin offset Degree minute (Decimal degree)	Minimum		12°00' (12.00°)		11°45' (11.75°)	
	Nominal		12°45' (12.75°)		12°30' (12.50°)	
	Maximum		13°30' (13.50°)		13°15' (13.25°)	
Total toe-in	Distance (A - B)	Minimum	0 mm (0 in)		0.5 (0.02)	
		Nominal	1 mm (0.04 in)		1.5 (0.06)	
		Maximum	2 mm (0.08 in)		2.5 (0.10)	
Wheel turning angle			Refer to ST-32 , "Steering Angle".			

★: Fuel, radiator coolant and engine oil full. Spare tire, jack, hand tools and mats in designated positions.

COUPE

Market			USA/Canada		Mexico	
Engine type			QR25DE and VQ35DE		VQ35DE	
Tire size			215/60R16	235/45R18	235/45R18	
Camber Degree minute (Decimal degree)	LH	Minimum	-1°15' (-1.25°)		-1°09' (-1.15°)	
		Nominal	-0°30' (-0.50°)		-0°24' (-0.40°)	
		Maximum	0°15' (0.25°)		0°21' (0.35°)	
	RH	Minimum	-1°30' (-1.50°)		-1°24' (-1.40°)	
		Nominal	-0°45' (-0.75°)		-0°39' (-0.65°)	
		Maximum	0°00' (0.00°)		-0°06' (-0.10°)	
	Left and right difference		-0°15' ± 0° 33' (-0.25° ± 0.55°)			
Caster Degree minute (Decimal degree)	Minimum		4°15' (4.25°)		3°57' (3.95°)	
	Nominal		5°00' (5.00°)		4°42' (4.70°)	
	Maximum		5°45' (5.75°)		5°27' (5.45°)	
	Left and right difference		± 0° 33' (± 0.55°)			

SERVICE DATA AND SPECIFICATIONS (SDS)

< SERVICE DATA AND SPECIFICATIONS (SDS)

Kingpin offset Degree minute (Decimal degree)	Minimum	12°00' (12.00°)	11°50' (11.83°)
	Nominal	12°45' (12.75°)	12°35' (12.58°)
	Maximum	13°30' (13.50°)	13°20' (13.33°)
Total toe-in	Distance (A - B)	Minimum	0 mm (0 in)
		Nominal	1 mm (0.04 in)
		Maximum	2 mm (0.08 in)
Wheel turning angle	Refer to ST-32. "Steering Angle" .		

★: Fuel, radiator coolant and engine oil full. Spare tire, jack, hand tools and mats in designated positions.

Ball Joint

INFOID:000000004205276

Swing torque	0.50 - 3.4 N·m (0.06 - 0.34 kg·m, 5 - 30 in·lb)
Measurement on spring balance (cotter pinhole position)	7.94 - 53.97 N (0.81 - 5.50 kg, 1.79 - 12.2 lb)
Rotating torque	0.50 - 3.4 N·m (0.06 - 0.34 kg·m, 5 - 30 in·lb)
Axial endplay	0.1 mm (0.004 in) or less

Wheelarch Height (Unladen*1)

INFOID:000000004523222

SEDAN (QR25DE)

Unit: mm (in)

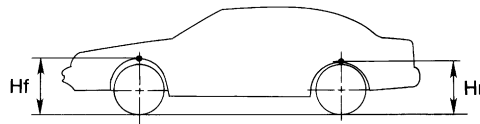

SFA818A

Market	USA	Canada	Mexico
Tire size	P215/60R16	P215/60R16	P215/60R16
Front (Hf)	717 (28.23)	715 (28.15)	727 (28.62)
Rear (Hr)	711 (27.99)	715 (28.15)	731 (28.78)

*1: Fuel, engine coolant and engine oil full. Spare tire, jack, hand tools and mats in designated positions.

SEDAN (VQ35DE)

Unit: mm (in)

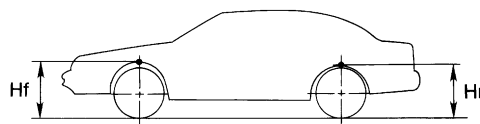

SFA818A

Market	USA		Canada		Mexico
Tire size	P215/60R16	P215/55R17	P215/60R16	P215/55R17	P215/55R17

SERVICE DATA AND SPECIFICATIONS (SDS)

< SERVICE DATA AND SPECIFICATIONS (SDS)

Front (Hf)	716 (28.19)	715 (28.15)	714 (28.11)	716 (28.19)	725 (28.54)
Rear (Hr)	711 (27.99)	711 (27.99)	715 (28.15)	711 (27.99)	731 (28.78)

*1: Fuel, engine coolant and engine oil full. Spare tire, jack, hand tools and mats in designated positions.

COUPE

Unit: mm (in)

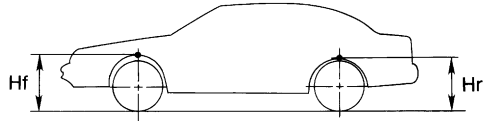

SFA818A

Market	USA		Canada		Mexico
	QR25DE	VQ35DE	QR25DE	VQ35DE	
Engine	QR25DE	VQ35DE	QR25DE	VQ35DE	VQ35DE
Tire size	P215/60R16	P235/45R18	P215/60R16	P235/45R18	P235/45R18
Front (Hf)	715 (28.15)	713 (28.07)	713 (28.07)	711 (27.99)	723 (28.46)
Rear (Hr)	722 (28.43)	722 (28.43)	727 (28.62)	726 (28.58)	722 (28.43)

*1: Fuel, engine coolant and engine oil full. Spare tire, jack, hand tools and mats in designated positions.