

SECTION VTL
VENTILATION SYSTEM

A
B
C

CONTENTS

PRECAUTION	3	BLOWER UNIT	13	F
PRECAUTIONS	3	Removal and Installation	13	
Precaution for Supplemental Restraint System (SRS) "AIR BAG" and "SEAT BELT PRE-TEN- SIONER"	3	BLOWER MOTOR	14	G
Precautions For High-Voltage System	3	Removal and Installation	14	
Precaution for Working with HFC-134a (R-134a).....	3	FAN CONTROL AMPLIFIER	15	H
Precaution for Procedure without Cowl Top Cover.....	4	Removal and Installation	15	
PREPARATION	5	INTAKE DOOR MOTOR	16	VTL
PREPARATION	5	Removal and Installation	16	
Commercial Service Tool	5	HEATER & COOLING UNIT ASSEMBLY	17	J
FUNCTION DIAGNOSIS	6	Removal and Installation	17	
IN-CABIN MICROFILTER	6	MODE DOOR MOTOR	19	K
Description	6	Removal and Installation	19	
ON-VEHICLE MAINTENANCE	7	AIR MIX DOOR MOTOR	20	L
IN-CABIN MICROFILTER	7	Removal and Installation	20	
Removal and Installation	7	EVAPORATOR	21	M
ON-VEHICLE REPAIR	8	Removal and Installation	21	
CONTROLLER	8	HEATER CORE	22	N
Removal and Installation	8	Removal and Installation	22	
IN-VEHICLE SENSOR	9	DUCTS AND GRILLES	23	O
Removal and Installation	9	DUCTS, NOZZLES AND GRILLES	23	
SUNLOAD SENSOR	10	DUCTS, NOZZLES AND GRILLES : Components...23		P
Removal and Installation	10	CENTER VENTILATOR GRILLES	24	
AMBIENT SENSOR	11	CENTER VENTILATOR GRILLES : Removal and Installation	24	
Removal and Installation	11	SIDE VENTILATOR GRILLES	24	
INTAKE SENSOR	12	SIDE VENTILATOR GRILLES : Removal and In- stallation	25	
Removal and Installation	12	UPPER VENTILATOR DUCT	25	
		UPPER VENTILATOR DUCT : Removal and In- stallation	25	

FRONT DEFROSTER NOZZLE, SIDE DEFROSTER NOZZLES AND VENTILATOR DUCT	25	REAR VENTILATOR GRILLE	25
FRONT DEFROSTER NOZZLE, SIDE DEFROSTER NOZZLES AND VENTILATOR DUCT : Removal and Installation	25	REAR VENTILATOR GRILLE : Removal and Installation	25
SIDE DEFROSTER GRILLES	25	REAR VENTILATOR DUCTS	25
SIDE DEFROSTER GRILLES : Removal and Installation	25	REAR VENTILATOR DUCTS : Removal and Installation	26
		REAR FLOOR DUCTS	26
		REAR FLOOR DUCTS : Removal and Installation...	26

PRECAUTIONS

< PRECAUTION >

PRECAUTION

PRECAUTIONS

Precaution for Supplemental Restraint System (SRS) "AIR BAG" and "SEAT BELT PRE-TENSIONER"

INFOID:000000003070694

The Supplemental Restraint System such as "AIR BAG" and "SEAT BELT PRE-TENSIONER", used along with a front seat belt, helps to reduce the risk or severity of injury to the driver and front passenger for certain types of collision. This system includes seat belt switch inputs and dual stage front air bag modules. The SRS system uses the seat belt switches to determine the front air bag deployment, and may only deploy one front air bag, depending on the severity of a collision and whether the front occupants are belted or unbelted. Information necessary to service the system safely is included in the SR and SB section of this Service Manual.

WARNING:

- To avoid rendering the SRS inoperative, which could increase the risk of personal injury or death in the event of a collision which would result in air bag inflation, all maintenance must be performed by an authorized NISSAN/INFINITI dealer.
- Improper maintenance, including incorrect removal and installation of the SRS, can lead to personal injury caused by unintentional activation of the system. For removal of Spiral Cable and Air Bag Module, see the SR section.
- Do not use electrical test equipment on any circuit related to the SRS unless instructed to in this Service Manual. SRS wiring harnesses can be identified by yellow and/or orange harnesses or harness connectors.

Precautions For High-Voltage System

INFOID:000000003070695

Refer to [GI-24. "Precautions For High-Voltage System"](#).

Precaution for Working with HFC-134a (R-134a)

INFOID:000000003070696

WARNING:

- CFC-12 (R-12) refrigerant and HFC-134a (R-134a) refrigerant are not compatible. If the refrigerants are mixed electric compressor failure is likely to occur. Refer to [HA-25. "Checking of Refrigerant Leaks"](#). To determine the purity of HFC-134a (R-134a) in the vehicle and recovery tank, use Refrigerant Recovery/Recycling Recharging equipment and Refrigerant Identifier.
- Use only specified electric compressor oil for the HFC-134a (R-134a) A/C system and HFC-134a (R-134a) components. If electric compressor oil other than that specified is used, electric compressor failure is likely to occur.
- The specified HFC-134a (R-134a) electric compressor oil rapidly absorbs moisture from the atmosphere. The following handling precautions must be observed:
 - When removing refrigerant components from a vehicle, immediately cap (seal) the component to minimize the entry of moisture from the atmosphere.
 - When installing refrigerant components to a vehicle, do not remove the caps (unseal) until just before connecting the components. Connect all refrigerant loop components as quickly as possible to minimize the entry of moisture into the system.
 - Only use the specified electric compressor oil from a sealed container. Immediately reseal containers of electric compressor oil. Without proper sealing, electric compressor oil will become moisture saturated and should not be used.
 - Avoid breathing A/C refrigerant and electric compressor oil vapor or mist. Exposure may irritate eyes, nose and throat. Remove HFC-134a (R-134a) from the A/C system using certified service equipment meeting requirements of SAE J2210 [HFC-134a (R-134a) recycling equipment], or J2209 [HFC-134a (R-134a) recycling equipment], If accidental system discharge occurs, ventilate work area before resuming service. Additional health and safety information may be obtained from refrigerant and electric compressor oil manufacturers.
 - Do not allow electric compressor oil to come in contact with styrofoam parts. Damage may result.

PRECAUTIONS

< PRECAUTION >

Precaution for Procedure without Cowl Top Cover

INFOID:000000003070697

When performing the procedure after removing cowl top cover, cover the lower end of windshield with urethane, etc.

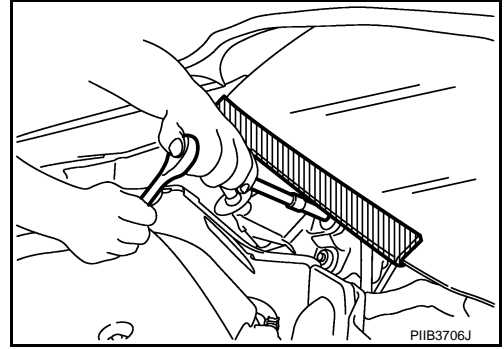

PREPARATION

< PREPARATION >

PREPARATION

PREPARATION

Commercial Service Tool

INFOID:000000003070698

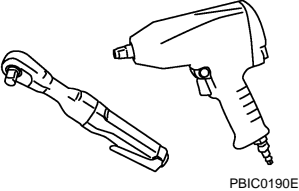
Tool number Tool name	Description
Power tool 	Removing bolts and nuts

A

B

C

D

E

F

G

H

VTL

J

K

L

M

N

O

P

IN-CABIN MICROFILTER

< FUNCTION DIAGNOSIS >

FUNCTION DIAGNOSIS

IN-CABIN MICROFILTER

Description

INFOID:000000003070699

FUNCTION

Air inside the passenger compartment is kept clean on either recirculation mode or fresh mode by installing an in-cabin microfilter into the heater and cooling unit assembly.

IN-CABIN MICROFILTER

< ON-VEHICLE MAINTENANCE >

ON-VEHICLE MAINTENANCE

IN-CABIN MICROFILTER

Removal and Installation

INFOID:000000003070700

REMOVAL

1. Remove the glove box assembly. Refer to [IP-11. "Removal and Installation"](#).
2. Remove the console side finisher (RH). Refer to [IP-11. "Removal and Installation"](#).
3. Disengage the filter cover tab (1) to remove the filter cover.
4. Remove the in-cabin microfilter from the blower unit by using the pull tab on the bottom of the filter.

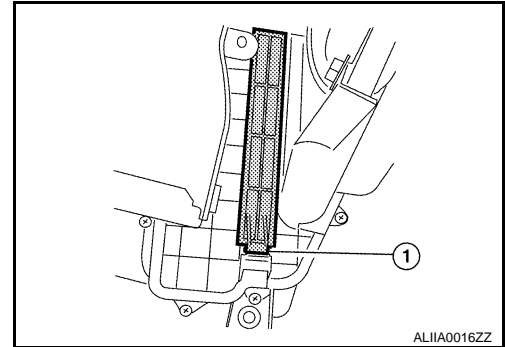

INSTALLATION

Installation is in the reverse order of removal.

A
B
C
D
E
F
G
H
J
K
L
M
N
O
P

VTL

CONTROLLER

< ON-VEHICLE REPAIR >

ON-VEHICLE REPAIR

CONTROLLER

Removal and Installation

INFOID:000000003070701

FRONT AIR CONTROL

Removal

1. Remove cluster lid D. Refer to [JP-11, "Removal and Installation"](#).
2. Remove the two brackets (1) and remove the controller (auto amp.).

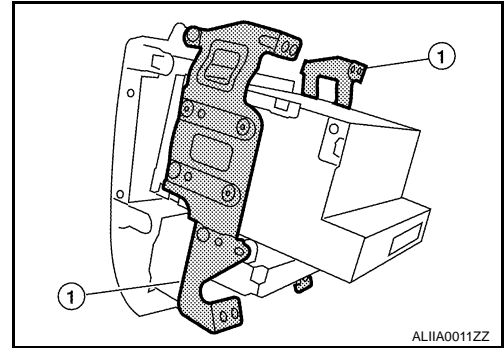

Installation

Installation is in the reverse order of removal.

IN-VEHICLE SENSOR

< ON-VEHICLE REPAIR >

IN-VEHICLE SENSOR

Removal and Installation

INFOID:000000003070702

REMOVAL

1. Remove the instrument lower cover LH. Refer to [IP-11. "Removal and Installation"](#).
2. Remove the in-vehicle sensor screw and remove the in-vehicle sensor.

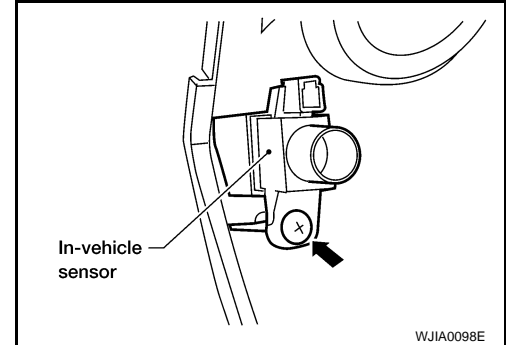

INSTALLATION

Installation is in the reverse order of removal.

- Make sure that the aspirator hose is securely attached to the in-vehicle sensor when installing the instrument lower cover LH.

A
B
C
D
E
F
G
H
J
K
L
M
N
O
P

VTL

SUNLOAD SENSOR

< ON-VEHICLE REPAIR >

SUNLOAD SENSOR

Removal and Installation

INFOID:000000003070703

REMOVAL

1. Remove the front RH speaker grille (1). Refer to [IP-11. "Removal and Installation"](#).
2. Disconnect the connector.
3. Release the sunload sensor tabs (A) to remove it from the front RH speaker grille (1).

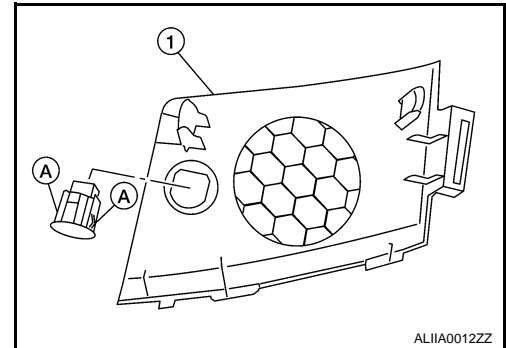

INSTALLATION

Installation is in the reverse order of removal.

AMBIENT SENSOR

< ON-VEHICLE REPAIR >

AMBIENT SENSOR

Removal and Installation

INFOID:000000003070704

REMOVAL

1. From under the vehicle, disconnect the ambient sensor connector from the ambient sensor (1).
2. Release the ambient sensor clip and remove the ambient sensor (1).

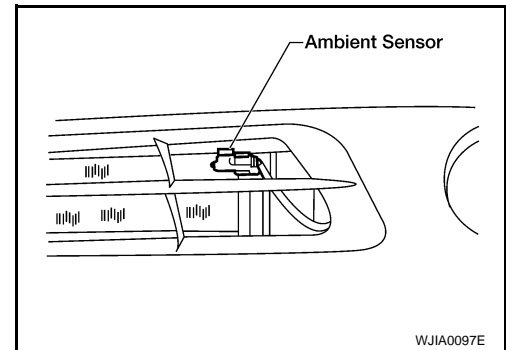

INSTALLATION

Installation is in the reverse order of removal.

A

B

C

D

E

F

G

H

VTL

J

K

L

M

N

O

P

INTAKE SENSOR

< ON-VEHICLE REPAIR >

INTAKE SENSOR

Removal and Installation

INFOID:000000003070705

REMOVAL

1. Remove the evaporator. Refer to [VTL-21. "Removal and Installation"](#).
2. Release the intake sensor clip and then remove the intake sensor.

CAUTION:

- Mark the mounting position of the intake sensor.
- Do not damage the evaporator core.

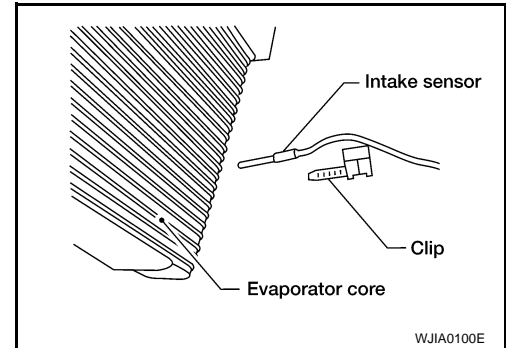

INSTALLATION

Installation is in the reverse order of removal.

BLOWER UNIT

< ON-VEHICLE REPAIR >

BLOWER UNIT

Removal and Installation

INFOID:000000003070706

COMPONENTS

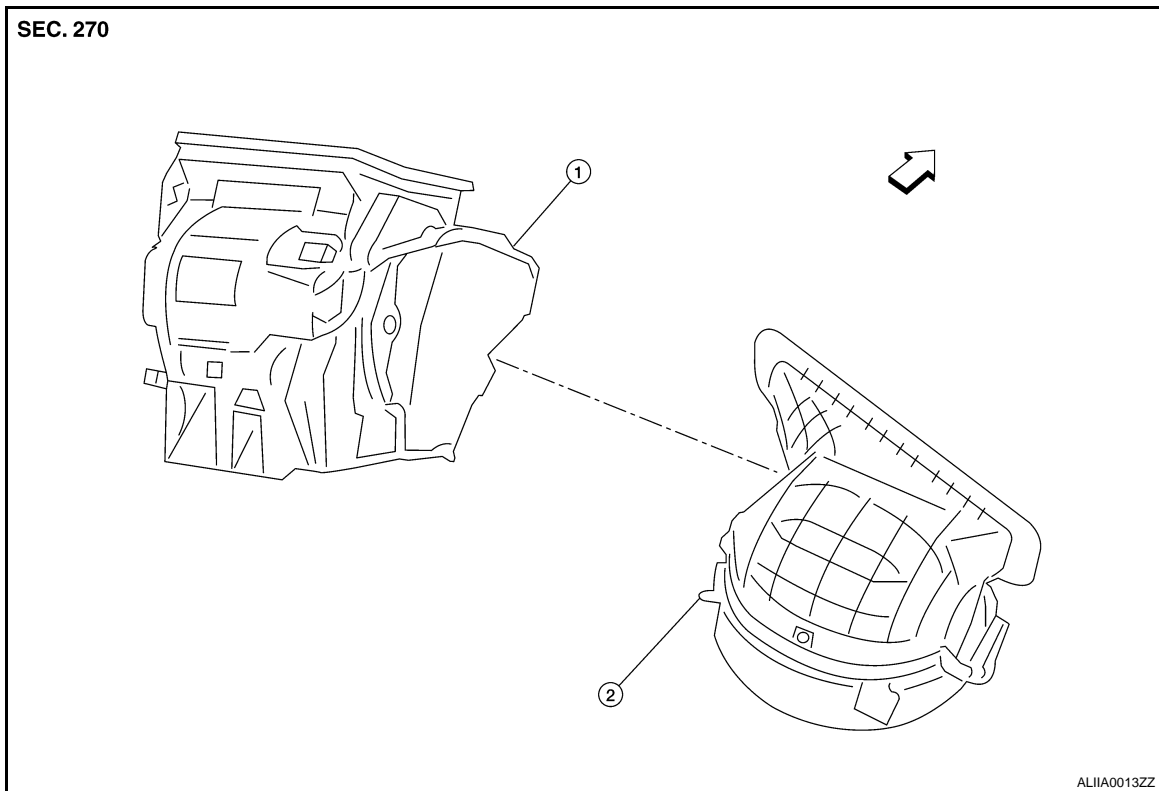

1. Heater and cooling unit

2. Blower unit

← Front

REMOVAL

1. Remove the heater and cooling unit assembly. Refer to [VTL-17, "Removal and Installation"](#).
2. Disconnect the blower motor connector.
3. Remove the screws from the blower unit, then remove the blower unit.

INSTALLATION

Installation is in the reverse order of removal.

A

B

C

D

E

F

G

H

VTL

J

K

L

M

N

O

P

BLOWER MOTOR

< ON-VEHICLE REPAIR >

BLOWER MOTOR

Removal and Installation

INFOID:000000003070707

REMOVAL

1. Remove the glove box. Refer to [IP-11. "Removal and Installation"](#).
2. Disconnect the blower motor connector (1).
3. Remove the three blower motor screws (A) and remove the blower motor from the blower unit.

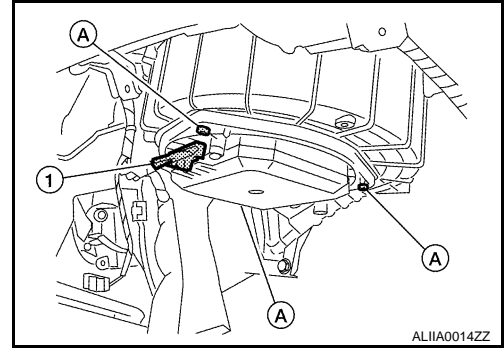

INSTALLATION

Installation is in the reverse order of removal.

FAN CONTROL AMPLIFIER

< ON-VEHICLE REPAIR >

FAN CONTROL AMPLIFIER

Removal and Installation

INFOID:000000003070708

The fan control amplifier is part of the blower motor. Refer to [VTL-14, "Removal and Installation"](#).

- A
- B
- C
- D
- E
- F
- G
- H
- VTL
- J
- K
- L
- M
- N
- O
- P

INTAKE DOOR MOTOR

< ON-VEHICLE REPAIR >

INTAKE DOOR MOTOR

Removal and Installation

INFOID:000000003070709

REMOVAL

1. Remove the instrument panel assembly. Refer to [VTL-13. "Removal and Installation"](#).
2. Disconnect the intake door motor connector (1).
3. Remove the intake door motor screws (A) and remove intake door motor from the blower unit.

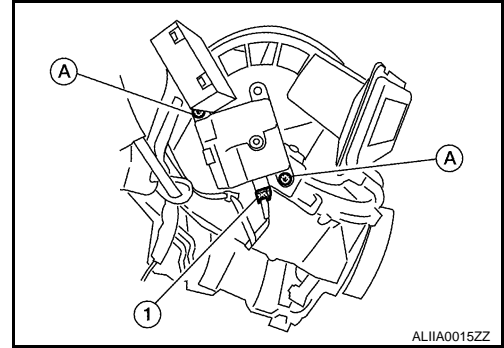

INSTALLATION

Installation is in the reverse order of removal.

HEATER & COOLING UNIT ASSEMBLY

< ON-VEHICLE REPAIR >

HEATER & COOLING UNIT ASSEMBLY

Removal and Installation

INFOID:000000003070710

COMPONENTS

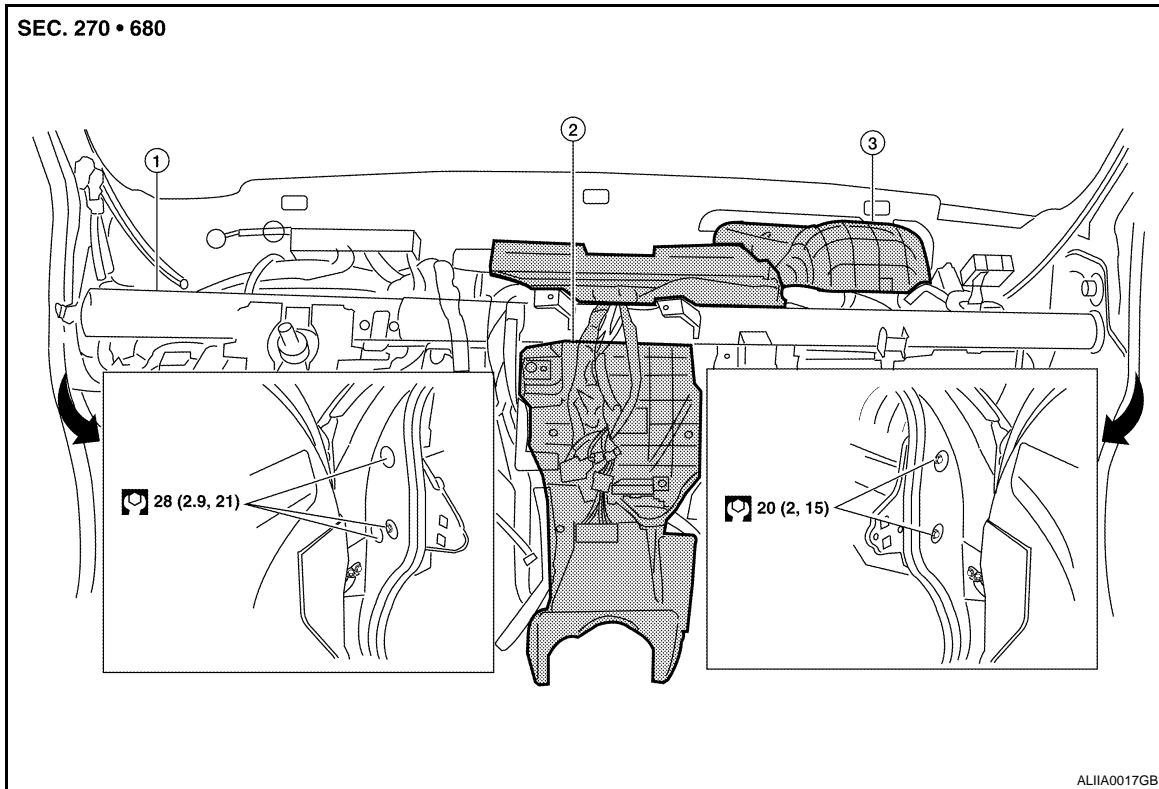

1. Steering member

2. Heater and cooling unit

3. Blower unit

REMOVAL

1. Discharge the refrigerant from the A/C system. Refer to [HA-23, "HFC-134a \(R-134a\) Service Procedure"](#).
2. Drain the engine coolant from the cooling system. Refer to [CO-11, "Changing Engine Coolant"](#).
3. Disconnect the 12-volt battery negative terminal.
4. Remove the wiper motor and linkage. Refer to [WW-41, "FRONT WIPER DRIVE ASSEMBLY : Removal and Installation"](#).
5. Remove the strut tower bar. Refer to [FSU-13, "Exploded View"](#).
6. Remove the cowl top. Refer to [EXT-17, "Removal and Installation"](#).
7. Remove the lower RH cowl. Refer to [EXT-17, "Removal and Installation"](#).
8. Disconnect the heater hoses from the heater core pipes.
CAUTION:
Cap or wrap the pipe joint with a suitable material such as vinyl tape to avoid the entry of contaminants into the system.
9. Disconnect the refrigerant lines from the expansion valve. Refer to [HA-29, "Component"](#).
CAUTION:
Cap or wrap the line joint with a suitable material such as vinyl tape to avoid the entry of contaminants into the system.
10. Remove the instrument panel assembly. Refer to [JP-11, "Removal and Installation"](#).
11. Remove the steering column assembly. Refer to [ST-9, "Removal and Installation"](#).
12. Disconnect the drain hose.
13. Remove the heater and cooling unit assembly attached to the steering member as one assembly from the vehicle.

HEATER & COOLING UNIT ASSEMBLY

< ON-VEHICLE REPAIR >

14. Remove the blower unit from the heater and cooling unit and steering member assembly.
15. Remove the heater and cooling unit from the steering member.

INSTALLATION

Installation is in the reverse order of removal.

- Fill the radiator with the specified water and coolant mixture. Refer to [MA-10, "Fluids and Lubricants"](#).
- Recharge the A/C system. Refer to [HA-23, "HFC-134a \(R-134a\) Service Procedure"](#).

CAUTION:

Replace the O-rings with new ones, then apply electric compressor oil to them when installing them.

MODE DOOR MOTOR

< ON-VEHICLE REPAIR >

MODE DOOR MOTOR

Removal and Installation

INFOID:000000003070711

REMOVAL

1. Remove the combination meter. Refer to [MWI-135, "Removal and Installation"](#).
2. Remove the BCM (2). Refer to [BCS-85, "Removal and Installation"](#).

NOTE:

The illustration is shown with the heater and cooling unit assembly out of the vehicle for clarity.

3. Disconnect the mode door motor connector (1).
4. Remove the mode door motor screws (A) and then remove the mode door motor.

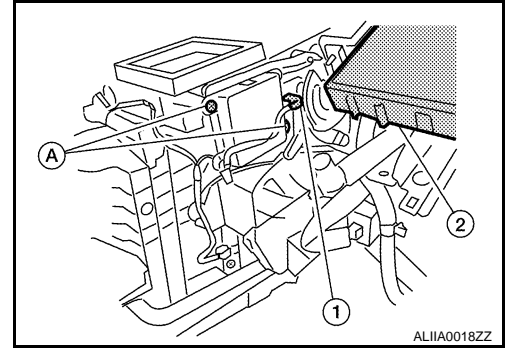

INSTALLATION

Installation is in the reverse order of removal.

A
B
C
D
E
F
G
H
J
K
L
M
N
O
P

VTL

AIR MIX DOOR MOTOR

< ON-VEHICLE REPAIR >

AIR MIX DOOR MOTOR

Removal and Installation

INFOID:000000003070712

AIR MIX DOOR MOTOR - LH

Removal

1. Remove the instrument lower cover LH. Refer to [IP-11, "Removal and Installation"](#).
2. Remove the center console side finisher LH. Refer to [IP-11, "Removal and Installation"](#).
3. Remove the heater and cooling unit foot duct LH (2).
4. Remove the tire pressure monitoring system receiver.
5. Disconnect the air mix door motor connector (1).
6. Remove the air mix door motor screws (A) and then remove the air mix door motor LH.

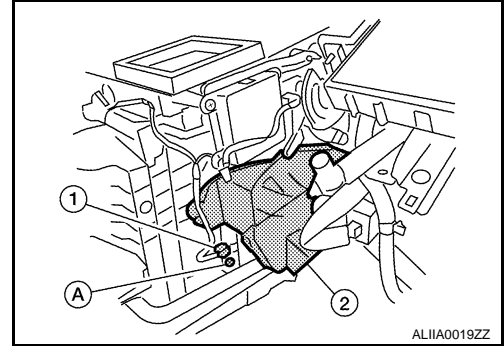

Installation

Installation is in the reverse order of removal.

AIR MIX DOOR MOTOR - RH

Removal

1. Remove the glove box. Refer to [IP-11, "Removal and Installation"](#).
2. Remove the heater and cooling unit foot duct LH (2).
3. Disconnect the air mix door motor connector (1).
4. Remove the air mix door motor screws (A) and then remove the air mix door motor RH.

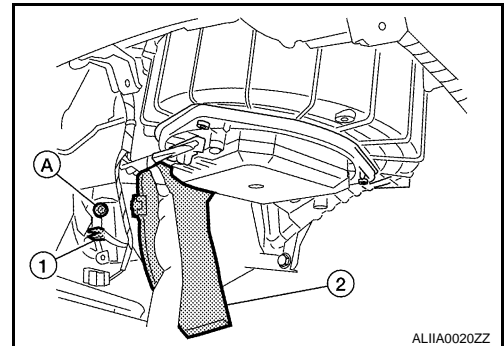

Installation

Installation is in the reverse order of removal.

EVAPORATOR

< ON-VEHICLE REPAIR >

EVAPORATOR

Removal and Installation

INFOID:000000003070713

COMPONENTS

Heater and Cooling Unit

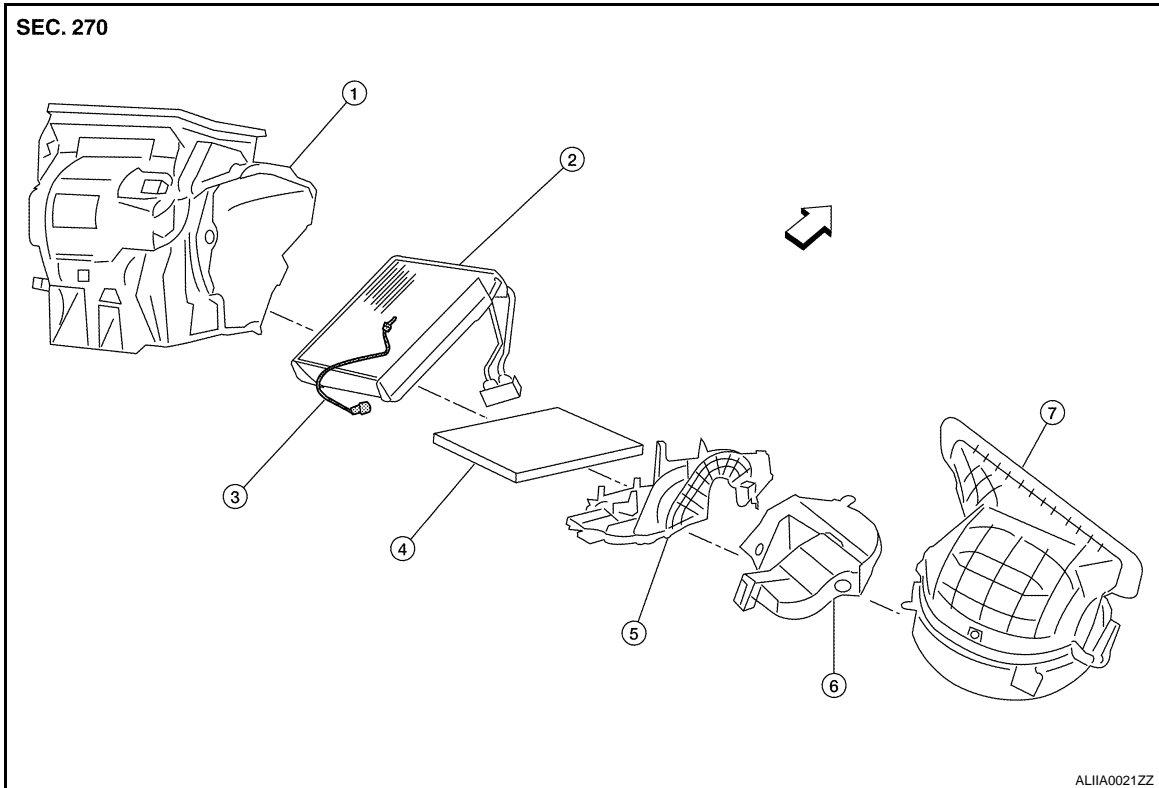

- | | | |
|---------------------------------|--|---|
| 1. Heater and cooling unit case | 2. Evaporator and expansion valve assembly | 3. Intake sensor |
| 4. In-cabin microfilter | 5. Evaporator cover | 6. Heater and cooling unit foot duct RH |
| 7. Blower unit | ← Front | |

REMOVAL

NOTE:

The evaporator and expansion valve assembly cannot be disassembled. Replace them as an assembly.

1. Remove the heater and cooling unit assembly. Refer to [HA-30. "HFC-134a \(R-134a\) Service Procedure"](#).
2. Remove the blower unit. Refer to [VTL-13. "Removal and Installation"](#).
3. Remove the heater and cooling unit foot duct RH.
4. Remove the air mix door motor RH.
5. Remove the evaporator cover.
6. Remove the evaporator and expansion valve assembly.
 - Remove the intake sensor to transfer to the new evaporator and expansion valve assembly.

CAUTION:

- Cap or wrap the joint of the pipes with suitable material such as vinyl tape to avoid the entry of air.
- Mark the mounting position of the intake sensor.

INSTALLATION

Installation is in the reverse order of removal.

CAUTION:

Replace the O-rings with new ones, then apply electric compressor oil to them when installing them.

HEATER CORE

< ON-VEHICLE REPAIR >

HEATER CORE

Removal and Installation

INFOID:000000003070714

COMPONENTS

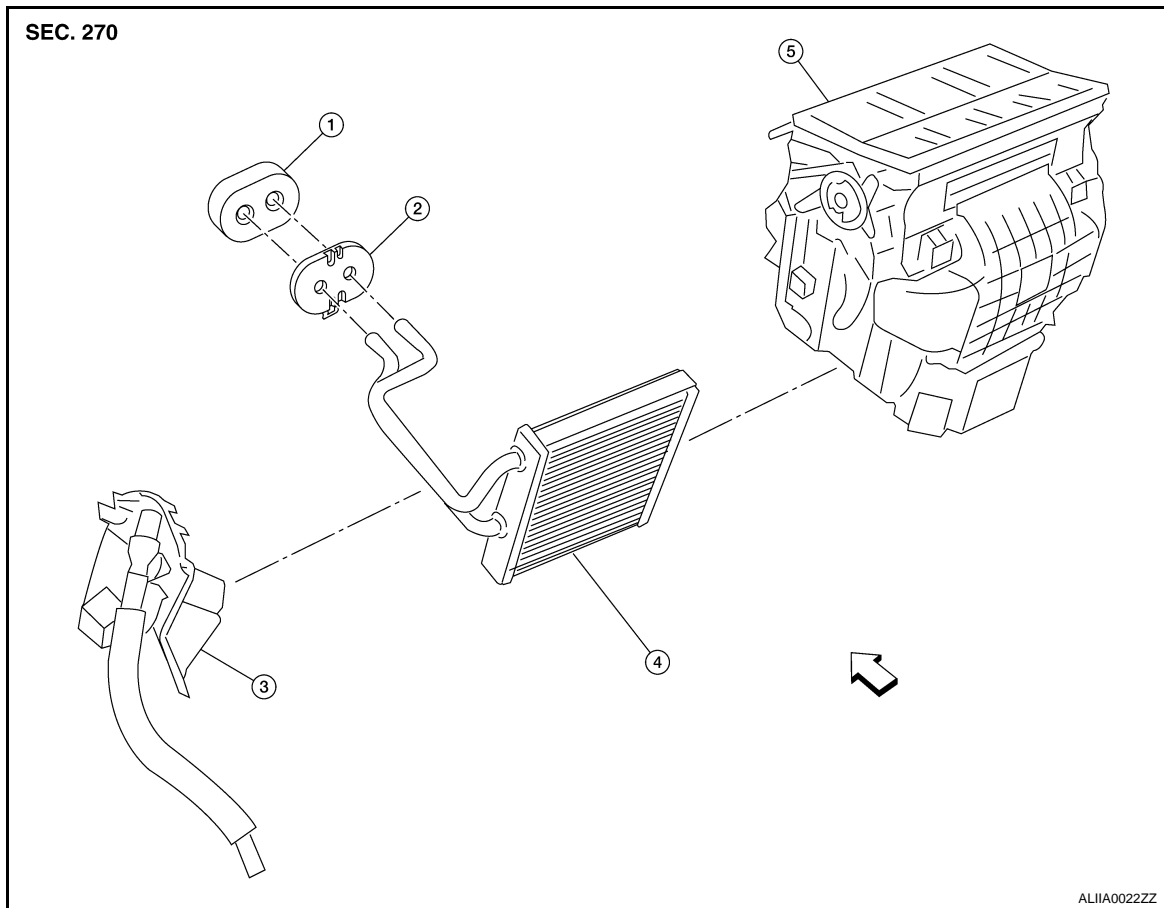

- | | | |
|-------------------|---------------------------------|---|
| 1. Heater grommet | 2. Heater pipe support | 3. Heater and cooling unit foot duct LH |
| 4. Heater core | 5. Heater and cooling unit case | ← Front |

REMOVAL

1. Remove the heater and cooling unit assembly. Refer to [VTL-17. "Removal and Installation"](#).
2. Remove the heater grommet, heater pipe support and heater pipe cover.
3. Remove the heater and cooling unit foot duct LH.
4. Remove the heater core.

INSTALLATION

Installation is in the reverse order of removal.

- Make sure that the aspirator hose is securely attached to the aspirator on the heater and cooling unit foot duct LH.

DUCTS AND GRILLES

< ON-VEHICLE REPAIR >

DUCTS AND GRILLES

DUCTS, NOZZLES AND GRILLES

DUCTS, NOZZLES AND GRILLES : Components

INFOID:000000003070715

Ducts

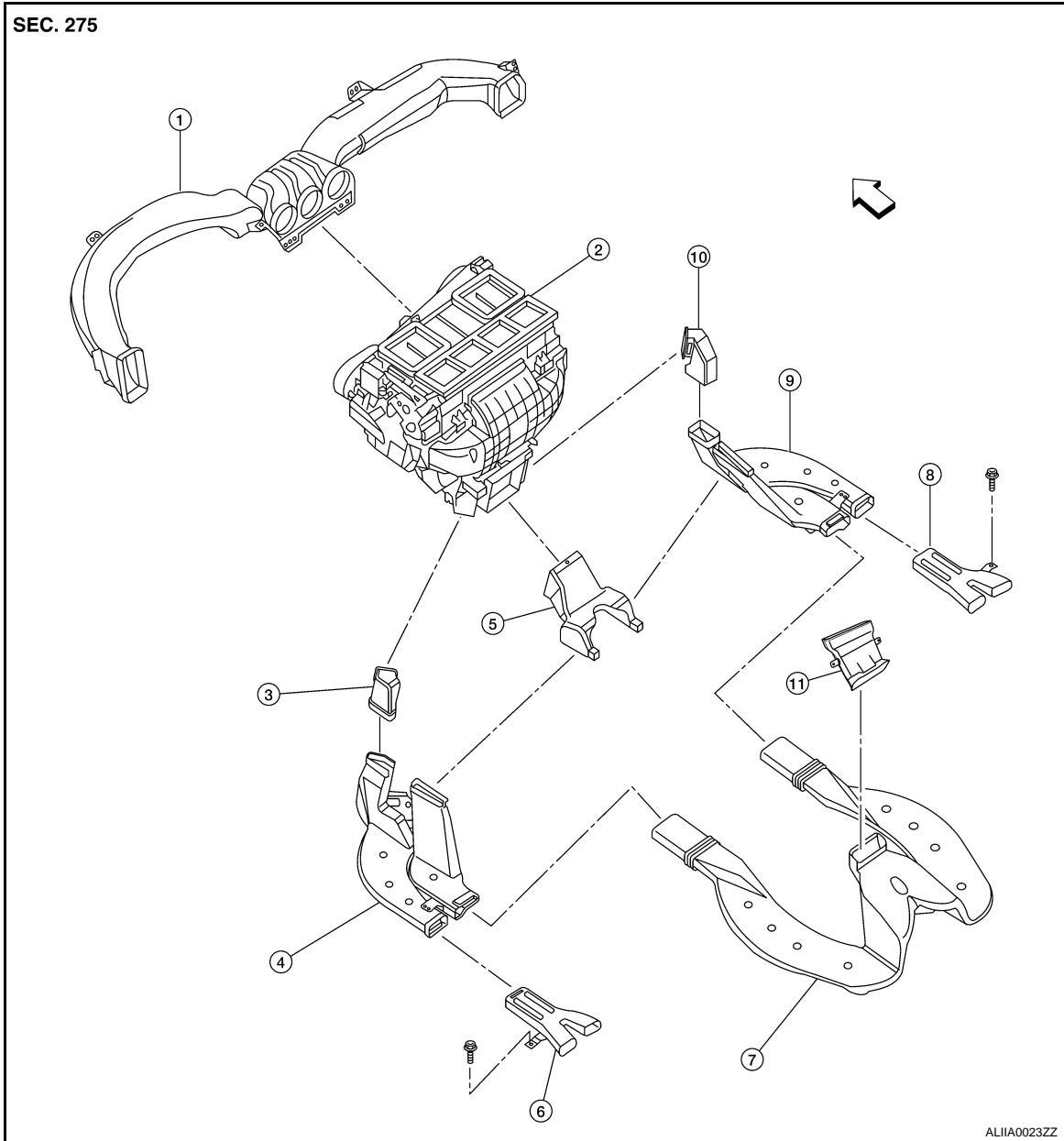

- | | | |
|----------------------------------|-------------------------------------|-------------------------------|
| 1. Upper ventilator duct | 2. Heater and cooling unit assembly | 3. Connector duct (LH) |
| 4. Floor ventilator duct (LH) | 5. Connector duct (center) | 6. Rear floor duct (LH) |
| 7. Rear ventilator duct (center) | 8. Rear floor duct (RH) | 9. Floor ventilator duct (RH) |
| 10. Connector duct (RH) | 11. Rear console duct | ← Front |

A
B
C
D
E
F
G
H
VTL
J
K
L
M
N
O
P

DUCTS AND GRILLES

< ON-VEHICLE REPAIR >

Grilles

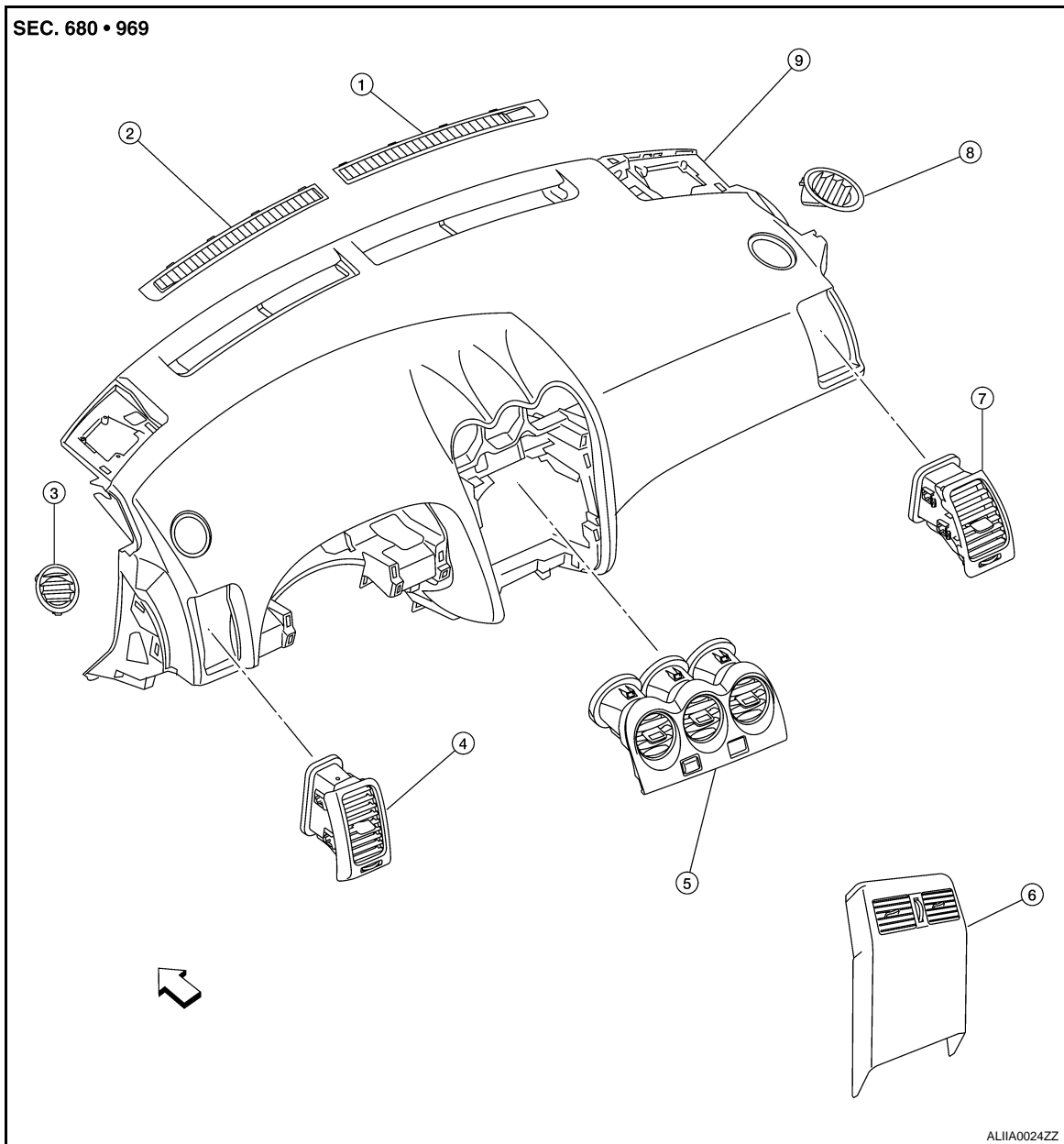

- | | | |
|--------------------------------|--|---|
| 1. Front defroster grille (RH) | 2. Front defroster grille (LH) | 3. Side defroster grille (LH) |
| 4. Side ventilator grille (LH) | 5. Center ventilator grilles (part of cluster lid C) | 6. Rear ventilator grille (part of rear console finisher) |
| 7. Side ventilator grille (RH) | 8. Side defroster grille (RH) | 9. Instrument panel |
- ← Front

CENTER VENTILATOR GRILLES

CENTER VENTILATOR GRILLES : Removal and Installation

INFOID:000000003070716

REMOVAL

1. Remove cluster lid C. Refer to [IP-11, "Removal and Installation"](#).

NOTE:

The center ventilator grilles are part of cluster lid C and replaced as an assembly.

INSTALLATION

Installation is in the reverse order of removal.

SIDE VENTILATOR GRILLES

DUCTS AND GRILLES

< ON-VEHICLE REPAIR >

SIDE VENTILATOR GRILLES : Removal and Installation

INFOID:000000003070717

REMOVAL

Release the tabs and then remove the side ventilator grilles.

CAUTION:

Use a suitable tool to remove the grille to avoid damage to the instrument panel.

INSTALLATION

Installation is in the reverse order of removal.

UPPER VENTILATOR DUCT

UPPER VENTILATOR DUCT : Removal and Installation

INFOID:000000003070718

REMOVAL

1. Remove the instrument panel. Refer to [IP-11, "Removal and Installation"](#).
2. Remove the upper ventilator duct screws using power tools.
3. Remove the upper ventilator duct.

INSTALLATION

Installation is in the reverse order of removal.

FRONT DEFROSTER NOZZLE, SIDE DEFROSTER NOZZLES AND VENTILATOR DUCT

FRONT DEFROSTER NOZZLE, SIDE DEFROSTER NOZZLES AND VENTILATOR DUCT : Removal and Installation

INFOID:000000003070719

REMOVAL

Remove the front defroster grille from the instrument panel.

CAUTION:

Use a suitable tool to remove the grille to avoid damage to the instrument panel.

INSTALLATION

Installation is in the reverse order of removal.

SIDE DEFROSTER GRILLES

SIDE DEFROSTER GRILLES : Removal and Installation

INFOID:000000003070720

REMOVAL

Remove side defroster grilles using a suitable tool.

CAUTION:

Use a suitable tool to remove the grille to avoid damage to the instrument panel.

INSTALLATION

Installation is in the reverse order of removal.

REAR VENTILATOR GRILLE

REAR VENTILATOR GRILLE : Removal and Installation

INFOID:000000003070721

REMOVAL

Remove console rear finisher. Refer to [IP-16, "Exploded View"](#).

NOTE:

The rear ventilator is part of the console rear finisher.

INSTALLATION

Installation is in the reverse order of removal.

REAR VENTILATOR DUCTS

A

B

C

D

E

F

G

H

VTL

J

K

L

M

N

O

P

DUCTS AND GRILLES

< ON-VEHICLE REPAIR >

REAR VENTILATOR DUCTS : Removal and Installation

INFOID:000000003070722

REAR VENTILATOR DUCT (CENTER)

Removal

1. Remove the floor carpet. Refer to [INT-16, "Removal and Installation"](#).
2. Remove the rear ventilator duct (center).

Installation

Installation is in the reverse order of removal.

FLOOR VENTILATOR DUCT (RH, LH)

Removal

1. Remove the floor carpet. Refer to [INT-16, "Removal and Installation"](#).
2. Remove the floor ventilator duct (RH, LH).

Installation

Installation is in the reverse order of removal.

REAR CONSOLE DUCT

Removal

1. Remove the center console. Refer to [IP-16, "Exploded View"](#).
2. Remove the rear console duct screws.
3. Remove the rear console duct.

Installation

Installation is in the reverse order of removal.

REAR FLOOR DUCTS

REAR FLOOR DUCTS : Removal and Installation

INFOID:000000003070723

REMOVAL

1. Remove the floor carpet. Refer to [INT-16, "Removal and Installation"](#).
2. Remove the rear floor duct (RH, LH) clips.
3. Remove the rear floor ducts (RH, LH).

INSTALLATION

Installation is in the reverse order of removal.