

SECTION **ST**
STEERING SYSTEM

A
 B
 C
 D
 E
 F
ST
 H
 I
 J
 K
 L
 M
 N
 O
 P

CONTENTS

SYMPTOM DIAGNOSIS	3	STEERING GEAR AND LINKAGE	17
NOISE, VIBRATION AND HARSHNESS (NVH) TROUBLESHOOTING	3	Exploded View	17
NVH Troubleshooting Chart	3	Removal and Installation	17
PRECAUTION	4	POWER STEERING OIL PUMP	19
PRECAUTIONS	4	QR25DE	19
Supplemental Restraint System (SRS) "AIR BAG" and "SEAT BELT PRE-TENSIONER"	4	QR25DE : Exploded View	19
Necessary for Steering Wheel Rotation after Battery Disconnect	4	QR25DE : Removal and Installation	19
General Precautions	4	VQ35DE	19
Service Notice or Precautions	4	VQ35DE : Exploded View	20
PREPARATION	6	VQ35DE : Removal and Installation	20
PREPARATION	6	HYDRAULIC LINE	21
Special Service Tool	6	QR25DE	21
Commercial Service Tool	7	QR25DE : Exploded View	21
ON-VEHICLE MAINTENANCE	8	QR25DE : Removal and Installation	22
POWER STEERING FLUID	8	VQ35DE	22
Inspection	8	VQ35DE : Exploded View	22
Draining	8	VQ35DE : Removal and Installation	23
Refilling	8	DISASSEMBLY AND ASSEMBLY	25
STEERING WHEEL	10	STEERING COLUMN	25
Inspection	10	Disassembly and Assembly	25
POWER STEERING OIL PUMP	12	STEERING GEAR AND LINKAGE	26
Inspection	12	Exploded View	26
ON-VEHICLE REPAIR	13	Disassembly	26
STEERING WHEEL	13	Inspection	26
Removal and Installation	13	Assembly	27
STEERING COLUMN	14	POWER STEERING OIL PUMP	29
Exploded View	14	QR25DE	29
Removal and Installation	14	QR25DE : Disassembly and Assembly	29
		VQ35DE	29
		VQ35DE : Disassembly and Assembly	29

SERVICE DATA AND SPECIFICATIONS**(SDS) 30****SERVICE DATA AND SPECIFICATIONS****(SDS) 30**

Steering Wheel 30

Steering Angle 30

Steering Column 30

Steering Gear 31

Oil Pump 32

Steering Fluid 32

NOISE, VIBRATION AND HARSHNESS (NVH) TROUBLESHOOTING

< SYMPTOM DIAGNOSIS >

SYMPTOM DIAGNOSIS

NOISE, VIBRATION AND HARSHNESS (NVH) TROUBLESHOOTING

NVH Troubleshooting Chart

INFOID:000000001342132

Use chart below to help you find the cause of the symptom. If necessary, repair or replace these parts.

Symptom	Steering	Possible cause and SUSPECTED PARTS																Reference page												
		Noise	Shake	Vibration	Shimmy	Shudder	Fluid level	Air in hydraulic system	Outer socket ball joint swinging force	Outer socket ball joint rotating torque	Outer socket ball joint end play	Steering fluid leakage	Steering wheel play	Steering gear rack sliding force	Drive belt looseness	Improper steering wheel	Improper installation or looseness of tilt lock lever	Mounting rubber deterioration	Steering column deformation or damage	Improper installation or looseness of steering column	Steering linkage looseness	WHEEL HUB	AXLE and SUSPENSION	TIRES	ROAD WHEEL	DRIVE SHAFT	BRAKES			
		x					x																							ST-8
		x																												—
		x																												ST-26
		x																												ST-26
		x																												ST-26
		x																												ST-8
		x																												ST-10
		x																												ST-26
		x																												EM-16, "Checking Drive Belts" (QR25DE), EM-121, "Checking Drive Belts" (VQ35DE)
			x																											—
				x																										—
				x																										ST-17
				x																										ST-25
				x																										ST-14
				x																										ST-17
				x																										Refer to FAX-2, "NVH Troubleshooting Chart"
				x																										Refer to FSU-2, "NVH Troubleshooting Chart"
				x																										Refer to WT-32, "NVH Troubleshooting Chart"
				x																										Refer to WT-32, "NVH Troubleshooting Chart"
				x																										Refer to FAX-2, "NVH Troubleshooting Chart"
				x																										Refer to BR-3, "NVH Troubleshooting Chart"

x: Applicable

A
B
C
D
E
F
ST
H
I
J
K
L
M
N
O
P

PRECAUTIONS

< PRECAUTION >

PRECAUTION

PRECAUTIONS

Supplemental Restraint System (SRS) "AIR BAG" and "SEAT BELT PRE-TENSIONER"

INFOID:000000001342133

The Supplemental Restraint System such as "AIR BAG" and "SEAT BELT PRE-TENSIONER", used along with a front seat belt, helps to reduce the risk or severity of injury to the driver and front passenger for certain types of collision. This system includes seat belt switch inputs and dual stage front air bag modules. The SRS system uses the seat belt switches to determine the front air bag deployment, and may only deploy one front air bag, depending on the severity of a collision and whether the front occupants are belted or unbelted. Information necessary to service the system safely is included in the SR and SB section of this Service Manual.

WARNING:

- To avoid rendering the SRS inoperative, which could increase the risk of personal injury or death in the event of a collision which would result in air bag inflation, all maintenance must be performed by an authorized NISSAN/INFINITI dealer.
- Improper maintenance, including incorrect removal and installation of the SRS, can lead to personal injury caused by unintentional activation of the system. For removal of Spiral Cable and Air Bag Module, see the SR section.
- Do not use electrical test equipment on any circuit related to the SRS unless instructed to in this Service Manual. SRS wiring harnesses can be identified by yellow and/or orange harnesses or harness connectors.

Necessary for Steering Wheel Rotation after Battery Disconnect

INFOID:000000001342134

NOTE:

- Before removing and installing any control units, first turn the push-button ignition switch to the LOCK position, then disconnect both battery cables.
- After finishing work, confirm that all control unit connectors are connected properly, then re-connect both battery cables.
- Always use CONSULT-III to perform self-diagnosis as a part of each function inspection after finishing work. If a DTC is detected, perform trouble diagnosis according to self-diagnosis results.

This vehicle is equipped with a push-button ignition switch and a steering lock unit.

If the battery is disconnected or discharged, the steering wheel will lock and cannot be turned.

If turning the steering wheel is required with the battery disconnected or discharged, follow the procedure below before starting the repair operation.

OPERATION PROCEDURE

1. Connect both battery cables.

NOTE:

Supply power using jumper cables if battery is discharged.

2. Carry the Intelligent Key or insert it to the key slot and turn the push-button ignition switch to ACC position. (At this time, the steering lock will be released.)
3. Disconnect both battery cables. The steering lock will remain released with both battery cables disconnected and the steering wheel can be turned.
4. Perform the necessary repair operation.
5. When the repair work is completed, re-connect both battery cables. With the brake pedal released, turn the push-button ignition switch from ACC position to ON position, then to LOCK position. (The steering wheel will lock when the push-button ignition switch is turned to LOCK position.)
6. Perform self-diagnosis check of all control units using CONSULT-III.

General Precautions

INFOID:000000001342135

Service Notice or Precautions

INFOID:000000001342136

- In case of removing steering gear assembly, make the final tightening with grounded and unloaded vehicle condition, and then check wheel alignment.

PRECAUTIONS

< PRECAUTION >

- Observe the following precautions when disassembling.
- Before disassembly, thoroughly clean the outside of the unit. A
- Disassembly should be done in a clean work area. It is important to prevent the internal parts from becoming contaminated by dirt or other foreign matter.
- For easier and proper assembly, place disassembled parts in order on a parts rack. B
- Use nylon cloth or paper towels to clean the parts; common shop rags can leave lint that might interfere with their operation.
- Do not reuse non-reusable parts.
- Before assembling, apply the specified grease to the directed parts. C

D

E

F

ST

H

I

J

K

L

M

N

O

P

PREPARATION

< PREPARATION >

PREPARATION

PREPARATION

Special Service Tool

INFOID:000000001342137

The actual shapes of Kent-Moore tools may differ from those of special service tools illustrated here.

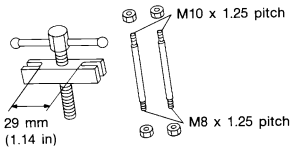
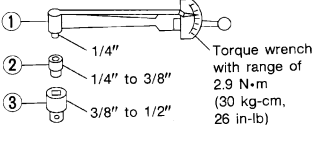
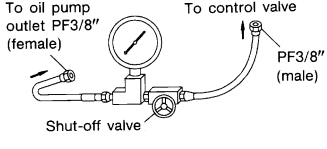
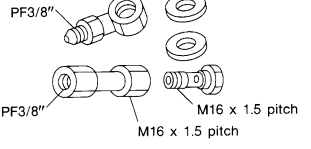
Tool number (Kent-Moore No.) Tool name	Description
ST27180001 (J-25726-A) Steering wheel puller <div style="text-align: center;">  <p>29 mm (1.14 in)</p> <p>M10 x 1.25 pitch</p> <p>M8 x 1.25 pitch</p> <p>S-NT544</p> </div>	Removing steering wheel
ST3127S000 (See J-25765-A) Preload gauge 1. GG9103000 (J-25765-A) Torque wrench 2. HT62940000 (-) Socket adapter 3. HT62900000 (-) Socket adapter <div style="text-align: center;">  <p>1 1/4"</p> <p>2 1/4" to 3/8"</p> <p>3 3/8" to 1/2"</p> <p>Torque wrench with range of 2.9 N·m (30 kg-cm, 26 in-lb)</p> <p>S-NT541</p> </div>	Inspecting of rotating torque for ball joint
KV48103500 (J-26357) Pressure gauge <div style="text-align: center;">  <p>To oil pump outlet PF3/8" (female)</p> <p>To control valve PF3/8" (male)</p> <p>Shut-off valve</p> <p>S-NT547</p> </div>	Measuring oil pump relief pressure
KV48102500 (J-33914) Pressure gauge adapter <div style="text-align: center;">  <p>PF3/8"</p> <p>PF3/8"</p> <p>M16 x 1.5 pitch</p> <p>M16 x 1.5 pitch</p> <p>S-NT542</p> </div>	Measuring oil pump relief pressure

PREPARATION

< PREPARATION >

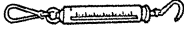
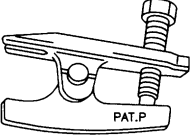
Tool number (Kent-Moore No.) Tool name	Description
— (J-44372) Spring gauge  LST024	Measuring steering wheel turning force or rack sliding force
HT72520000 (J-25730-A) Ball joint remover  PAT.P NT146	Removing ball joint

A
B
C
D
E
F

Commercial Service Tool

INFOID:000000001342138

ST

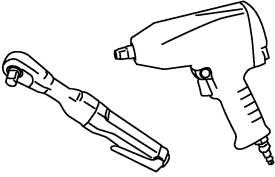
Tool number Tool name	Description
Power tool  PBIC0190E	<ul style="list-style-type: none"> • Removing wheel nuts • Removing undercover

H
I
J
K
L
M
N
O
P

POWER STEERING FLUID

< ON-VEHICLE MAINTENANCE >

ON-VEHICLE MAINTENANCE

POWER STEERING FLUID

Inspection

INFOID:000000001342139

FLUID LEVEL

- Check fluid level with engine stopped.
- Make sure that fluid level is between MIN and MAX.
- Fluid levels at HOT (A) and COLD (B) are different. Do not confuse them.

HOT (A) : Fluid temperature 50 - 80 °C (122 - 176°F)

COLD (B) : Fluid temperature 0 - 30°C (32 - 86°F)

CAUTION:

- The fluid level should not exceed the MAX line. Excessive fluid will cause fluid leakage from the cap.
- Do not reuse drained power steering fluid.
- Recommended fluid is Genuine Nissan PSF or equivalent.

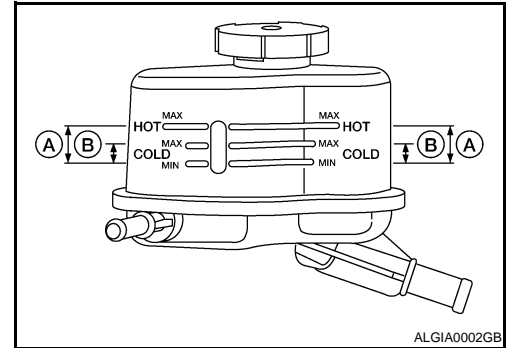

FLUID LEAKAGE

Check hydraulic connections for fluid leakage, cracks, damage, looseness, or wear.

1. Run engine until the fluid temperature reaches 50 to 80° C (122 to 176°F) in reservoir tank, and keep engine speed idle.
2. Turn steering wheel several times from full left stop to full right stop.
3. Hold steering wheel at each lock position for five seconds and carefully, check for fluid leakage.

CAUTION:

Do not hold the steering wheel in a locked position for more than 10 seconds. (There is the possibility that oil pump may be damaged.)

4. If fluid leakage at connections is noticed, then loosen flare nut and then retighten. Do not overtighten connector as this can damage O-ring, washer and connector.
5. If fluid leakage from oil pump is noticed, check oil pump. Refer to [ST-29](#) (QR25DE), [ST-29](#) (VQ35DE).
6. Check steering gear boots for accumulation of fluid indicating from steering gear.

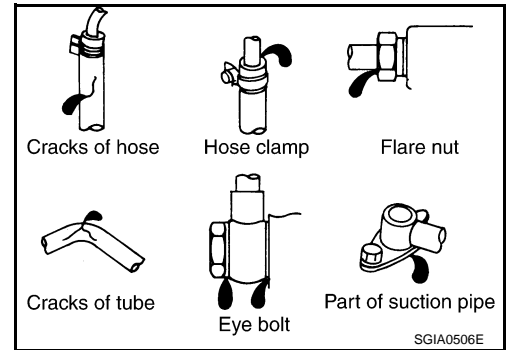

Draining

INFOID:000000001342140

1. Disconnect both high and low pressure lines from power steering gear.
2. Drain into a suitable container.

Refilling

INFOID:000000001342141

FILLING HYDRAULIC SYSTEM

1. Fill power steering reservoir while checking fluid level.
2. Bleed air from hydraulic system.
3. Check for fluid leaks.

AIR BLEEDING HYDRAULIC SYSTEM

If air bleeding is not complete, the following symptoms can be observed.

- Bubbles are created in reservoir tank.
- Clicking noise can be heard from oil pump.
- Excessive buzzing in the oil pump.

NOTE:

POWER STEERING FLUID

< ON-VEHICLE MAINTENANCE >

Fluid noise may occur in the steering gear or oil pump. This does not affect performance or durability of the system.

1. Turn steering wheel several times from full left stop to full right stop with engine off.

CAUTION:

Turn steering wheel while filling reservoir tank with fluid so as not to lower fluid level below the MIN line.

2. Start engine and hold steering wheel at each lock position for 3 seconds at idle to check for fluid leakage.
3. Repeat step 2 above several times at approximately 3 second intervals.

CAUTION:

Do not hold the steering wheel in a locked position for more than 10 seconds. (There is the possibility that oil pump may be damaged.)

4. Check fluid for bubbles and white contamination.
5. Stop engine if bubbles and white contamination do not drain out. Perform step 2 and 3 above after waiting until bubbles and white contamination drain out.
6. Stop the engine, and then check fluid level.

A
B
C
D
E
F
H
I
J
K
L
M
N
O
P

ST

STEERING WHEEL

< ON-VEHICLE MAINTENANCE >

STEERING WHEEL

Inspection

INFOID:000000001342142

INSTALLATION CONDITION

- Check installation conditions of steering gear assembly, front suspension assembly, axle and steering column assembly.
- Check if movement exists when steering wheel is moved up and down, to the left and right and to the axial direction.

Steering wheel axial end play : 0 mm (0 in)

- Check steering gear assembly bolts and nut for looseness. Refer to [ST-17, "Exploded View"](#).

STEERING WHEEL PLAY

- Turn steering wheel so that front wheels come to the straight-ahead position. Start engine and lightly turn steering wheel to the left and right until front wheels start to move. Measure steering wheel movement on the outer circumference.

Steering wheel play : 0 - 35 mm (0 - 1.38 in)

- When the measurement value is outside the standard value, check backlash for each joint of steering column assembly and installation condition of steering gear assembly.

NEUTRAL POSITION OF STEERING WHEEL

- Make sure that steering gear assembly, steering column assembly and steering wheel are installed in the correct position.
- Perform neutral position inspection after wheel alignment. Refer to [FSU-6, "Inspection and Adjustment"](#).
- Set vehicle to the straight-ahead position and confirm steering wheel is in the neutral position.
- Loosen outer socket lock nut and turn inner socket to left and right equally to make fine adjustments if steering wheel is not in the neutral position.

STEERING WHEEL TURNING FORCE

1. Park vehicle on a level, dry surface and set parking brake.
2. Start engine.
3. Bring power steering fluid up to adequate operating temperature. Make sure the fluid temperature is approximately 60° to 80°C (140° to 176°F).
Tires need to be inflated to normal pressure.
4. Check steering wheel turning force when steering wheel has been turned 360° from the neutral position.

Steering wheel turning force : 39 N (4 kg-f, 9 lb-f) or less

5. If steering wheel turning force is out of specification, check rack sliding force. Refer to [ST-26, "Inspection"](#).
6. If rack sliding force is not within specifications, adjust rack sliding force. Refer to [ST-26, "Inspection"](#).
7. If rack sliding force is OK, inspect steering column. Refer to [ST-14, "Removal and Installation"](#).

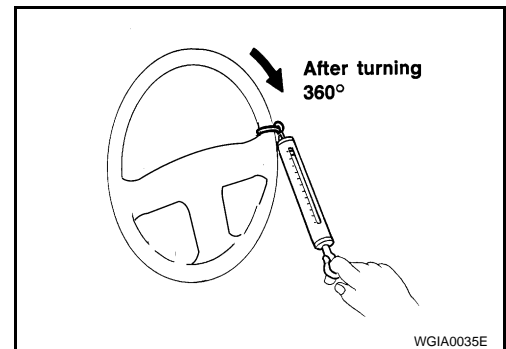

FRONT WHEEL TURNING ANGLE

STEERING WHEEL

< ON-VEHICLE MAINTENANCE >

- Check front wheel turning angle after toe-in inspection. Place front wheels on turning radius gauges and rear wheels on stands. Check the maximum inner and outer wheel turning angles for LH and RH road wheels.

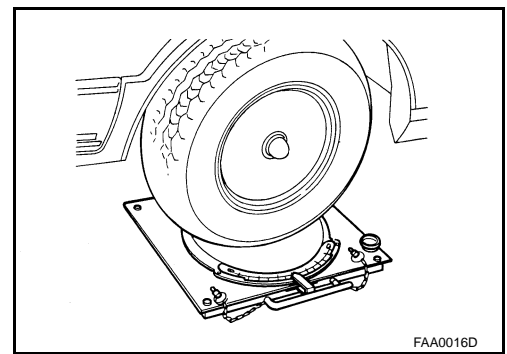

- With the engine at idle, turn steering wheel from full left stop to full right stop and measure the turning angles.

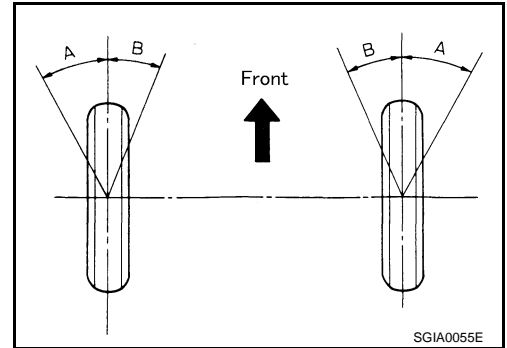

Unit: Degree minute (Decimal Degree)

Tire size		P215/60R16	P215/55R17
Inner wheel (Angle: A)	Minimum	35° 30' (35.5°)	33° 30' (33.5°)
	Nominal	38° 30' (38.5°)	36° 30' (36.5°)
	Maximum	39° 30' (39.5°)	37° 30' (37.5°)
Outer wheel (Angle: B)	Nominal	31° 30' (31.5°)	30° 30' (30.5°)

- Measure rack stroke if angles are outside the specified value.

Engine	QR25DE	VQ35DE
Rack stroke "L"	71.5 mm (2.815 in)	69.0 mm (2.717 in)

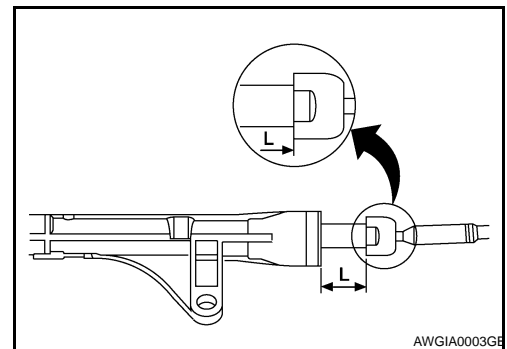

POWER STEERING OIL PUMP

< ON-VEHICLE MAINTENANCE >

POWER STEERING OIL PUMP

Inspection

INFOID:000000001342143

RELIEF OIL PRESSURE

CAUTION:

Make sure that belt tension is normal before starting the following procedure.

1. Connect the Tool between oil pump discharge connector and high-pressure hose. Bleed air from the hydraulic circuit while opening valve fully. Refer to [ST-8, "Inspection"](#).

Tool numbers : KV48103500 (J-26357),
KV48102500 (J-33914)

2. Start engine. Run engine until oil temperature reaches 50° to 80°C (122° to 176°F).

CAUTION:

- Leave the valve of the hydraulic pressure gauge [SST] fully open while starting and running engine. If engine is started with the valve closed, the hydraulic pressure in oil pump goes up to the relief pressure along with unusual increase of oil temperature.
 - Be sure to keep hose clear of belts and other parts when engine is started.
3. Fully close the Tool valve with engine at idle and measure the relief oil pressure.

Relief oil pressure:

8,520 - 9,320 kpa (86.9 - 95.1 kg/cm², 1,235 - 1,351 psi)

CAUTION:

Never keep valve closed for 10 seconds or longer.

4. Open the valve slowly after measuring. Replace oil pump is the relief oil pressure is outside the standard.
5. After inspection, disconnect the Tool from hydraulic circuit, then add fluid and bleed air. Refer to [ST-8, "Inspection"](#).

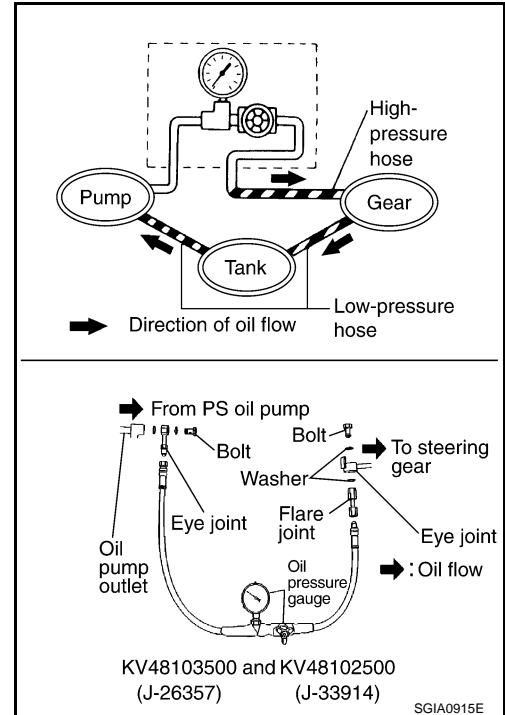

STEERING WHEEL

< ON-VEHICLE REPAIR >

ON-VEHICLE REPAIR

STEERING WHEEL

Removal and Installation

INFOID:000000001342144

REMOVAL

NOTE:

When reconnecting spiral cable, fix cable with a tape so that fixing case and rotating part keep aligned. This will omit neutral position alignment procedure during spiral cable installation.

1. Set vehicle to the straight-ahead position.
2. Remove driver air bag module. Refer to [SR-4, "Removal and Installation"](#).
3. Remove steering wheel lock nut after steering is locked.
4. Remove steering wheel using Tool (A).

Tool number A: ST27180001 (J-25726-A)

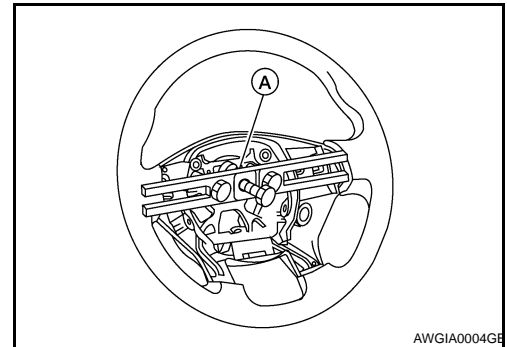

INSTALLATION

Installation is in the reverse order of removal.

1. Adjust the spiral cable locating pin (2) to the steering wheel locating pin hole (1).
2. Set the spiral cable neutral position.
 - Slowly turn the spiral cable clockwise to the end position.
 - Next, turn it counterclockwise (about 2.5 turns) then stop turning at the point when the alignment arrows (B) are directly across from each other.
 - Rotate the spiral cable slightly so the locating pin (2) is positioned at the top.
3. Align the locating hole (1) at the top of the steering wheel with the locating pin of spiral cable during installation.

NOTE:

A service part is installed in the neutral position with a stopper clip in place and should not be adjusted after the stopper clip is removed.

3. Align the locating hole (1) at the top of the steering wheel with the locating pin of spiral cable during installation.

CAUTION:

- The spiral cable may snap by steering operation if the cable is installed in an improper position.
- Do not turn the spiral cable quickly or beyond the limit number of turns. (This can cause the cable to snap.)
- After the work is completed, make sure no system malfunction is detected by air bag warning lamp.
- In case a malfunction is detected by the air bag warning lamp, reset with the self-diagnosis function and delete the memory with CONSULT-III.
- If a malfunction is still detected after the above operation, perform self-diagnosis to repair malfunctions. Refer to [SR-4, "Removal and Installation"](#).

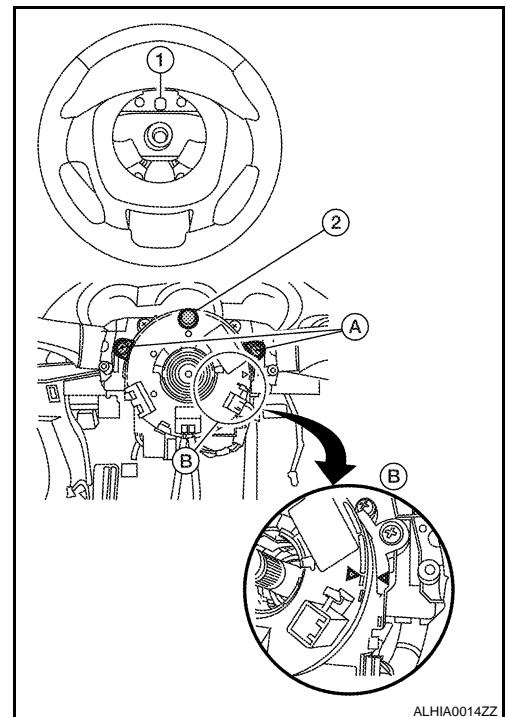

STEERING COLUMN

< ON-VEHICLE REPAIR >

STEERING COLUMN

Exploded View

INFOID:000000001342145

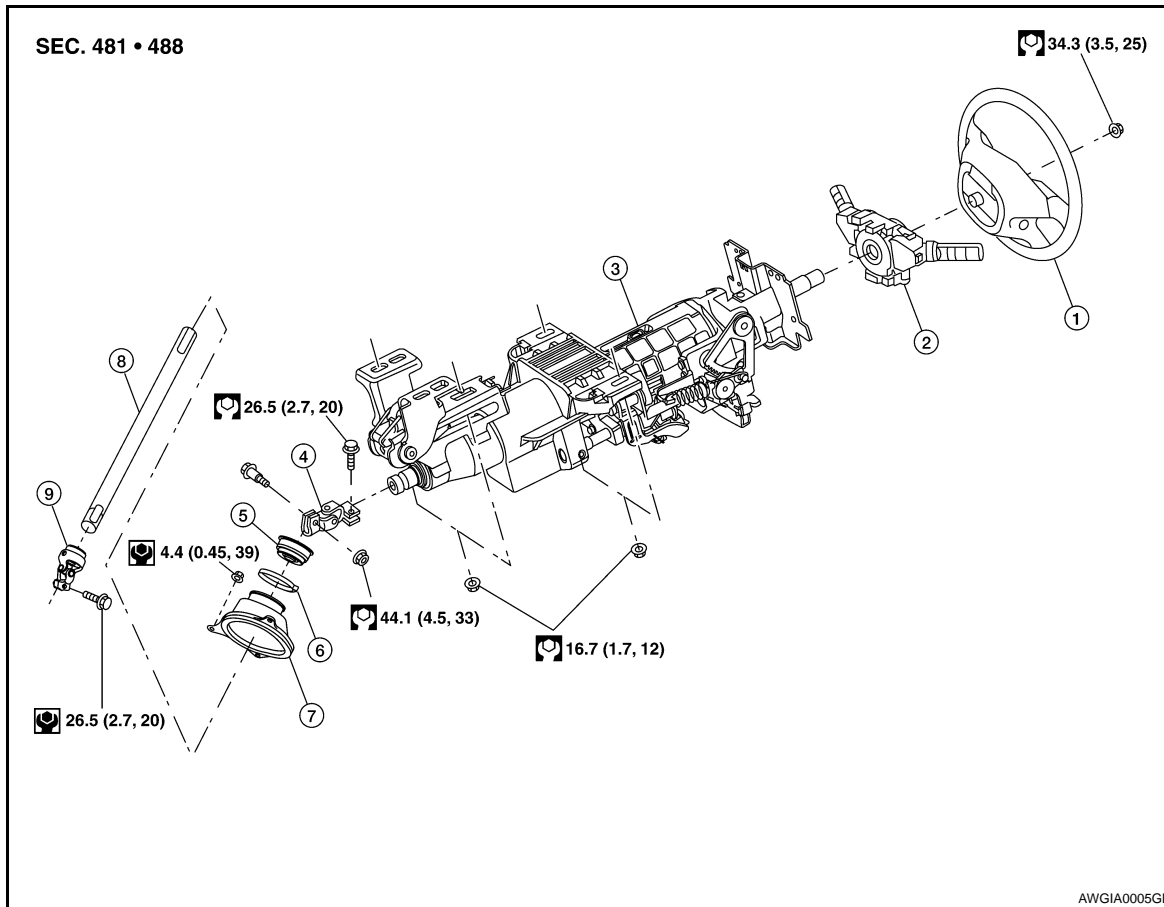

- | | | |
|-------------------|--------------------------------------|-----------------------------|
| 1. Steering wheel | 2. Combination switch & spiral cable | 3. Steering column assembly |
| 4. Upper joint | 5. Hole cover seal | 6. Herbie clip |
| 7. Hole cover | 8. Lower shaft | 9. Lower joint |

Removal and Installation

INFOID:000000001342146

REMOVAL

Upper Joint, Hole Cover Seal, Hole Cover, Lower Shaft and Lower Joint

1. Set wheels to the straight ahead-position.
2. Remove lower side bolt of lower joint.

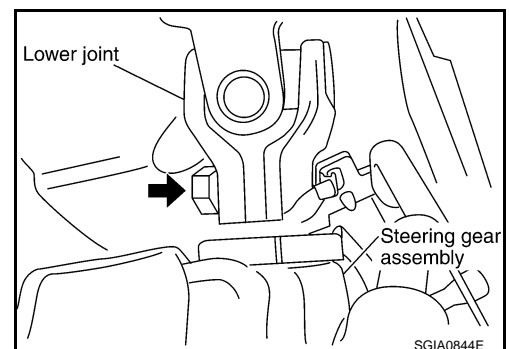

STEERING COLUMN

< ON-VEHICLE REPAIR >

3. Remove bolts and nut of upper joint (1), then remove lower shaft.
4. Loosen herbie clip, then remove hole cover seal from hole cover.
5. Remove nuts of hole cover, and then remove clamp and hole cover from dash panel.

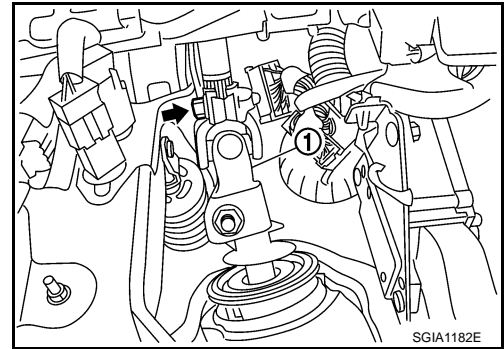

Steering Column Assembly

1. Set wheels to the straight-ahead position.
2. Remove driver air bag module. Refer to [SR-4. "Removal and Installation"](#).
3. Remove steering wheel. Refer to [ST-13. "Removal and Installation"](#).
4. Remove steering column cover. Refer to [IP-10. "Exploded View"](#).
5. Remove combination switch & spiral cable. Refer to [SR-6. "Removal and Installation"](#).
6. Remove instrument driver lower panel. Refer to [IP-10. "Exploded View"](#).
7. Remove knee protector (1) bolts, then remove knee protector (1). Refer to [IP-10. "Exploded View"](#).
8. Remove tire pressure receiver. Refer to [WT-36. "Removal and Installation"](#).
9. Disconnect each switch connector installed to steering column assembly, and then disconnect harness from steering column assembly.

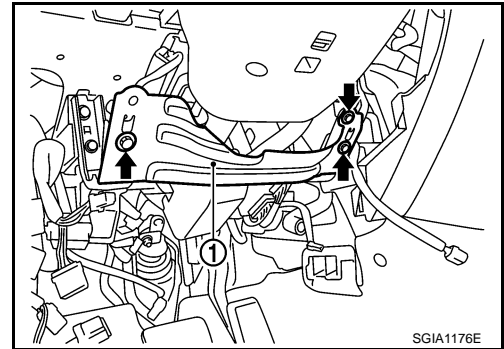

10. Remove bolt of upper joint (1) (steering column assembly side).
11. Remove steering column assembly bolts and nut, then remove steering column assembly.

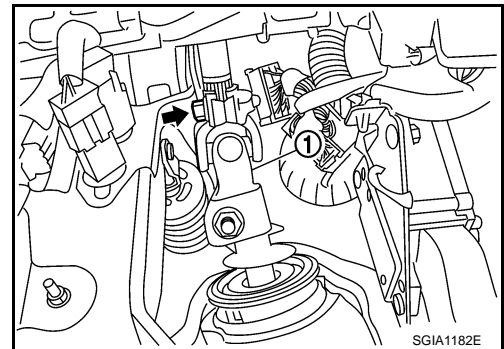

INSPECTION AFTER REMOVAL

Upper Joint, Hole Cover Seal, Hole Cover, Lower Shaft and Lower Joint

Check each part of hole cover seal, hole cover and steering column, lower shaft and lower joint for damage or other malfunctions. Replace if necessary.

Steering Column Assembly

- Check each part of steering column assembly for damage or other malfunctions. Replace if necessary.

STEERING COLUMN

< ON-VEHICLE REPAIR >

- Measure the length “L” as shown if vehicle has been involved in a minor collision. Replace steering column assembly if outside the specifications.

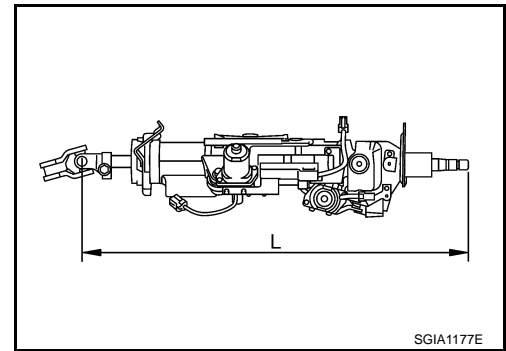

SGIA1177E

Steering column length “L”	Telescopic maximum	513 - 543 mm (20.20 - 21.38 in)
	Telescopic minimum	503 - 513 mm (19.80 - 20.20 in)

- Measure steering column rotating torque using preload gauge. Replace steering column assembly if outside the standard.

Rotating torque : 0 - 0.2 N·m (0 - 0.02 kg·m, 0 - 1 in·lb)

- Check tilt and telescopic mechanism operating range “L¹”, “L²” as shown.

Tilt operating range “L¹” : 41 mm (1.61 in)

Telescopic operating range “L²” : 40 mm (1.57 in)

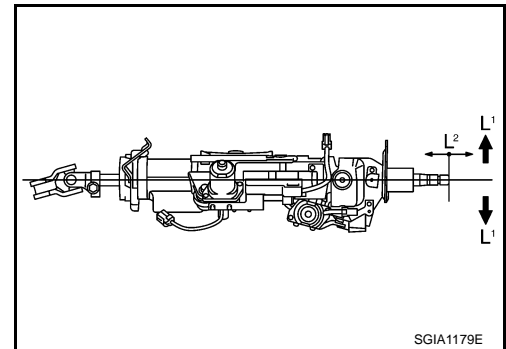

SGIA1179E

INSTALLATION

Steering Column Assembly

Installation is in the reverse order of removal. For tightening specifications, refer to [ST-14, "Exploded View"](#).

Hole Cover Seal, Hole Cover, Lower Shaft, Lower Joint and Steering Column

Installation is in the reverse order of removal. For tightening specifications, refer to [ST-14, "Exploded View"](#).

- When installing lower joint to steering gear assembly, follow the procedure listed below.
 - Set rack of steering gear in the neutral position.

NOTE:

To get the neutral position of rack, turn gear-sub assembly and measure the distance of inner socket, and then measure the intermediate position of the distance.

- Align rear cover cap projection (A) with the marking position (B) of gear housing assembly.
- Install slit part of lower joint (C) aligning with the projection (A) of rear cover cap (1). Make sure that the slit part of lower joint (C) is aligned with both the projection (A) of rear cover cap (1) and the marking position (B) of gear housing assembly.
- Perform final tightening of nuts and bolts on each part under unladen conditions with tires on level ground when removing steering gear assembly. Check wheel alignment. Refer to [FSU-6, "Inspection and Adjustment"](#).

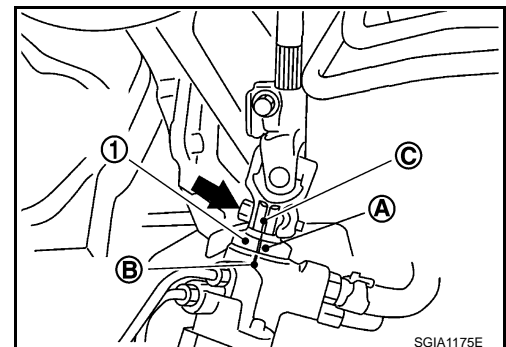

SGIA1175E

STEERING GEAR AND LINKAGE

< ON-VEHICLE REPAIR >

STEERING GEAR AND LINKAGE

Exploded View

INFOID:000000001342147

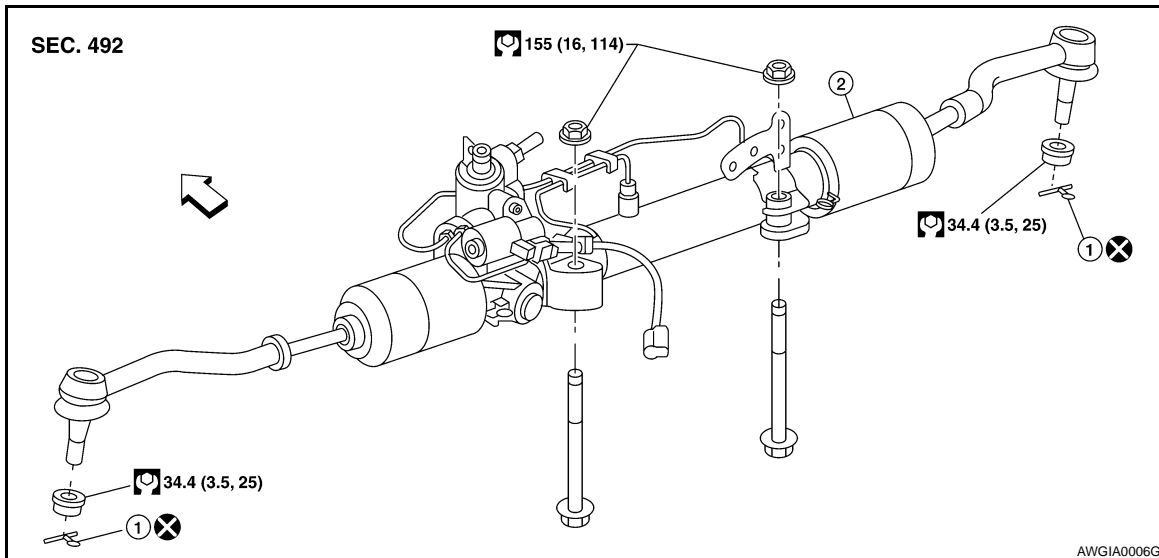

1. Cotter pin
2. Steering gear assembly

Removal and Installation

INFOID:000000001342148

REMOVAL

1. Remove tires using power tool.
2. Remove undercover using power tool.
3. Remove lower side bolt of lower joint.

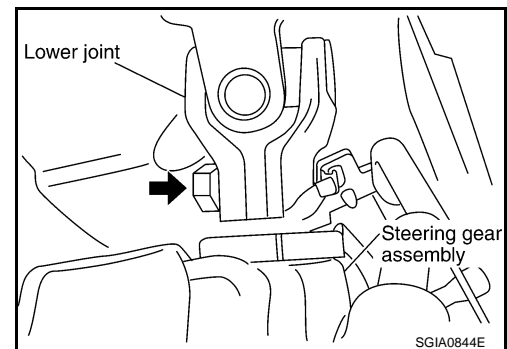

4. Remove cotter pin (1), and then loosen the nut.
5. Remove steering outer socket (2) from steering knuckle (3) so as not to damage ball joint boot (4) using the Tool.

CAUTION:

Temporarily tighten the nut to prevent damage to threads and to prevent the Tool from suddenly coming off.

Tool number : HT72520000 (J-25730-A)

6. Remove high and low pressure piping of hydraulic piping, and then drain power steering fluid. Refer to [ST-8, "Draining"](#).
7. Remove steering hydraulic piping bracket from front suspension member.
8. Remove SSPS valve harness connector. Refer to [ST-26, "Exploded View"](#).
9. Remove bolts and nuts of steering gear assembly, and then remove steering gear assembly from vehicle.

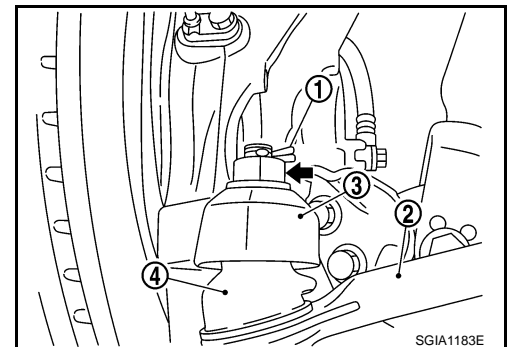

STEERING GEAR AND LINKAGE

< ON-VEHICLE REPAIR >

INSPECTION AFTER REMOVAL

Check for fluid leaks or damage to steering gear. If any exist, replace steering gear as an assembly.

INSTALLATION

Installation is in the reverse order of removal. For tightening specifications, refer to [ST-17, "Exploded View"](#).

- When installing lower joint to steering gear assembly, follow the procedure listed below.

- Set rack of steering gear in the neutral position.

NOTE:

To get the neutral position of rack, turn gear-sub assembly and measure the distance of inner socket, and then measure the intermediate position of the distance.

- Align rear cover cap projection (A) with the marking position (B) of gear housing assembly.

- Install slit part of lower joint (C) aligning with the projection (A) of rear cover cap (1). Make sure that the slit part of lower joint (C) is aligned with both the projection (A) of rear cover cap (1) and the marking position (B) of gear housing assembly.

- After installation, bleed air from the steering hydraulic system. Refer to [ST-8, "Inspection"](#).

- Perform final tightening of nuts and bolts on each part under unladen conditions with tires on level ground when removing steering gear assembly. Check wheel alignment. Refer to [FSU-6, "Inspection and Adjustment"](#).

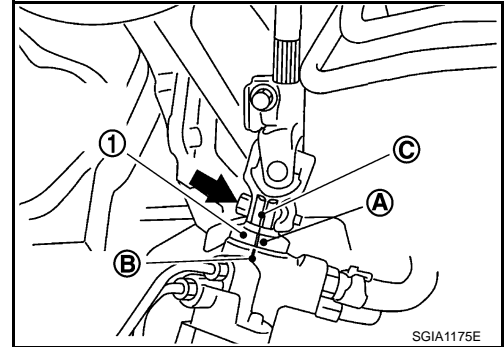

INSPECTION AFTER INSTALLATION

Make sure that steering wheel operates smoothly by turning several times from full left stop to full right stop.

POWER STEERING OIL PUMP

< ON-VEHICLE REPAIR >

POWER STEERING OIL PUMP

QR25DE

QR25DE : Exploded View

INFOID:000000001342149

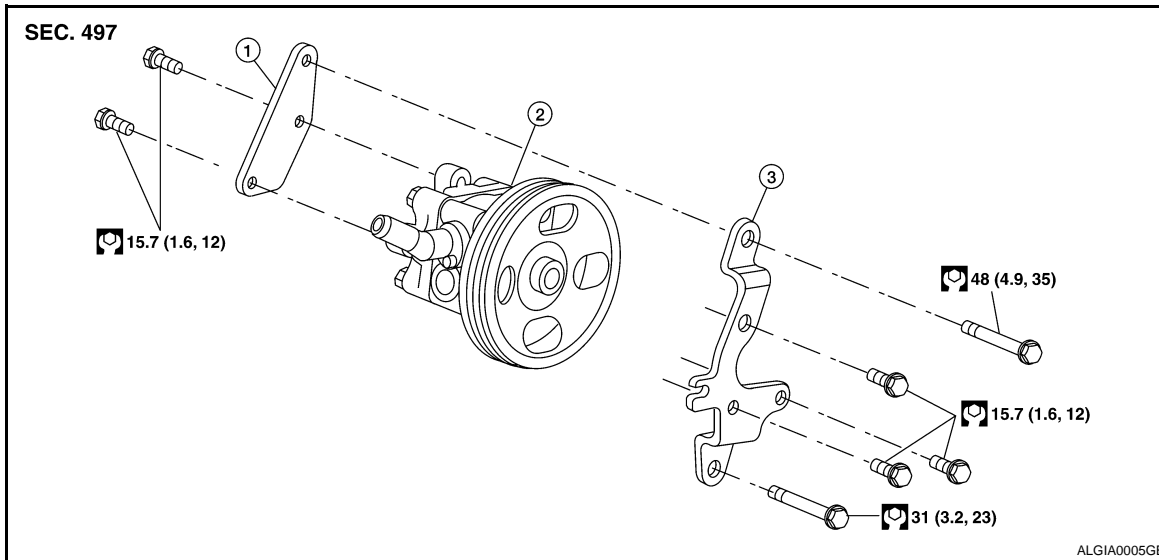

1. Rear bracket

2. Pump assembly

3. Front bracket

QR25DE : Removal and Installation

INFOID:000000001342150

REMOVAL

1. Drain power steering fluid from reservoir tank.
2. Remove undercover using power tool.
3. Loosen drive belt. Refer to [EM-16, "Removal and Installation"](#).
4. Remove drive belt from oil pump pulley.
5. Remove piping of high pressure and low pressure (drain fluid from pipings). Refer to [ST-21, "QR25DE : Exploded View"](#).
6. Remove oil pump bolts, and then remove power steering oil pump. Refer to [ST-19, "QR25DE : Exploded View"](#).

INSPECTION AFTER REMOVAL

INSTALLATION

Installation is in the reverse order of removal. For tightening specifications, refer to [ST-19, "QR25DE : Exploded View"](#).

- Perform the following procedure after installing.
 - For the installation of drive belt, refer to [EM-16, "Tension Adjustment"](#).
 - Bleed air. Refer to [ST-8, "Inspection"](#).

VQ35DE

POWER STEERING OIL PUMP

< ON-VEHICLE REPAIR >

VQ35DE : Exploded View

INFOID:000000001342151

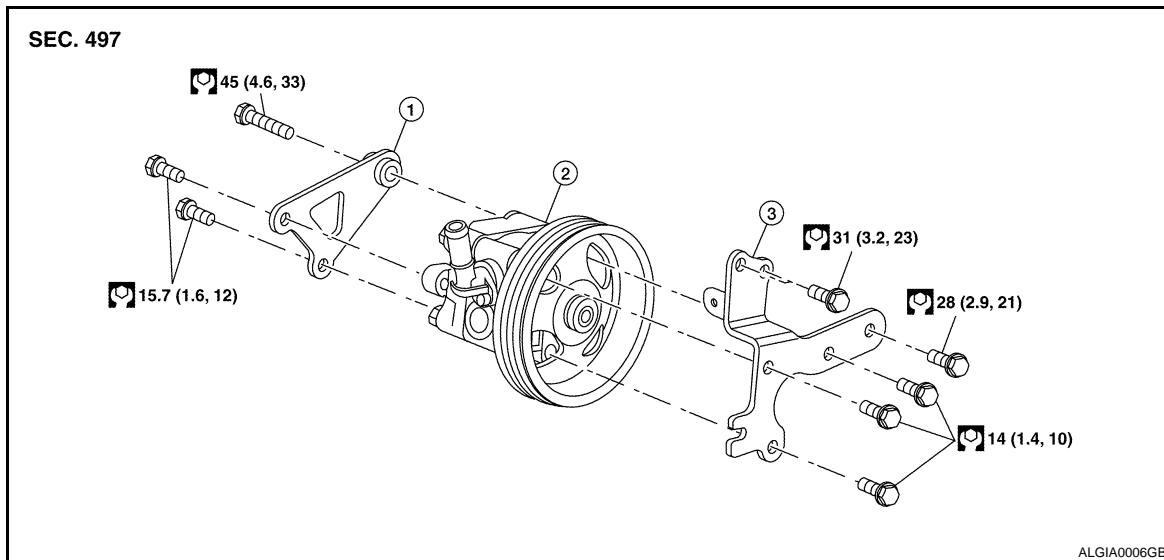

1. Rear bracket

2. Pump assembly

3. Front bracket

VQ35DE : Removal and Installation

INFOID:000000001342152

REMOVAL

1. Drain power steering fluid from reservoir tank.
2. Remove undercover using power tool.
3. Loosen drive belt. Refer to [EM-121, "Removal and Installation"](#).
4. Remove drive belt from oil pump pulley.
5. Remove piping of high pressure and low pressure (drain fluid from pipings). Refer to [ST-22, "VQ35DE : Exploded View"](#).
6. Remove oil pump bolts, and then remove power steering oil pump. Refer to [ST-20, "VQ35DE : Exploded View"](#).

INSPECTION AFTER REMOVAL

INSTALLATION

Installation is in the reverse order of removal.

- When installing power steering oil pump, install all bolts by hand initially, then tighten bolts to specification.
- Perform the following procedure after installing.
 - Adjust belt tension. Refer to [EM-121, "Tension Adjustment"](#).
 - Bleed air. Refer to [ST-8, "Inspection"](#).

HYDRAULIC LINE

< ON-VEHICLE REPAIR >

HYDRAULIC LINE

QR25DE

QR25DE : Exploded View

INFOID:000000001342153

CAUTION:

Securely insert harness connector to pressure sensor.

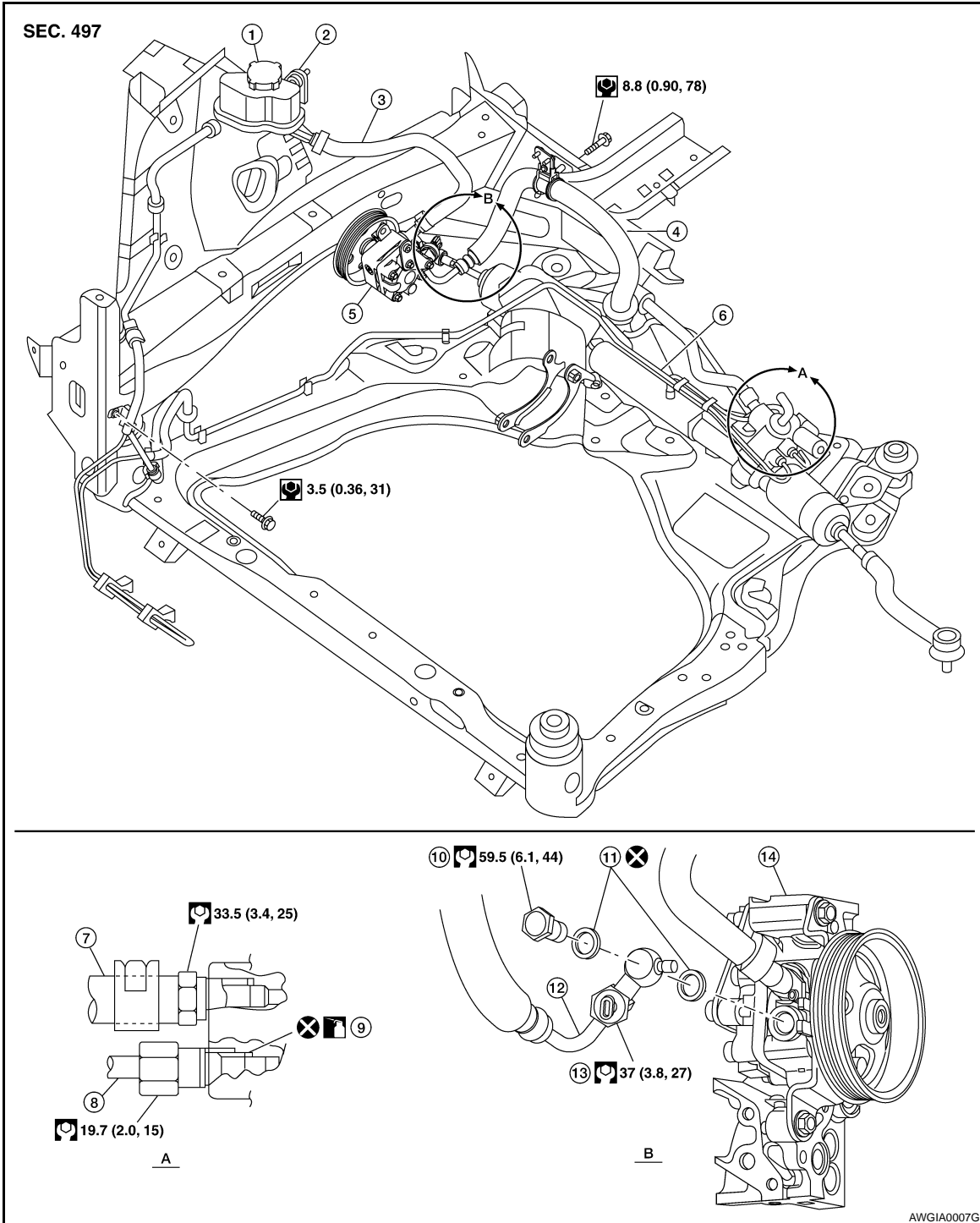

- | | | |
|------------------------|---------------------------|---------------------------|
| 1. Reservoir tank | 2. Reservoir tank bracket | 3. Suction hose |
| 4. High-pressure hose | 5. Oil pump assembly | 6. Steering gear assembly |
| 7. Low pressure piping | 8. High pressure piping | 9. O-ring |

HYDRAULIC LINE

< ON-VEHICLE REPAIR >

- | | | |
|---------------------|---|--|
| 10. Eye-bolt | 11. Copper washer | 12. Eye-joint (assembled to high-pressure side hose) |
| 13. Pressure sensor | 14. Oil pump bracket to engine block mounting point |  Apply Genuine Nissan PSF or equivalent |

QR25DE : Removal and Installation

INFOID:000000001342154

REMOVAL

Refer to [ST-21. "QR25DE : Exploded View"](#) for removal procedure.

INSTALLATION

- Insert hose securely until it contacts tube spool.

CAUTION:

Do not apply fluid.

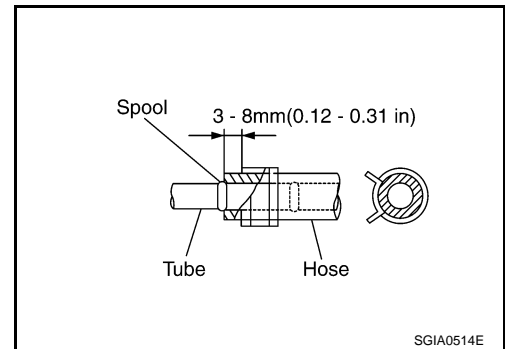

- Install eye-bolt with eye-joint (assembled to high-pressure hose) protrusion facing with pump side cutout, and then tighten it to the specified torque after tightening by hand.

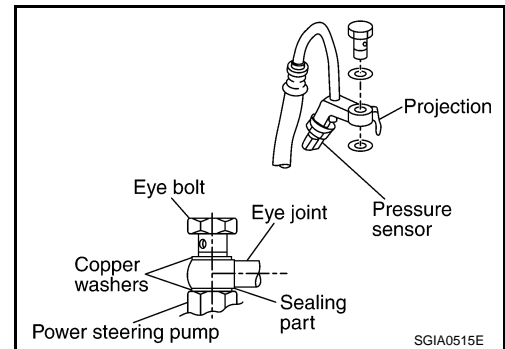

VQ35DE

VQ35DE : Exploded View

INFOID:000000001342155

CAUTION:

Securely insert harness connector to pressure sensor.

HYDRAULIC LINE

< ON-VEHICLE REPAIR >

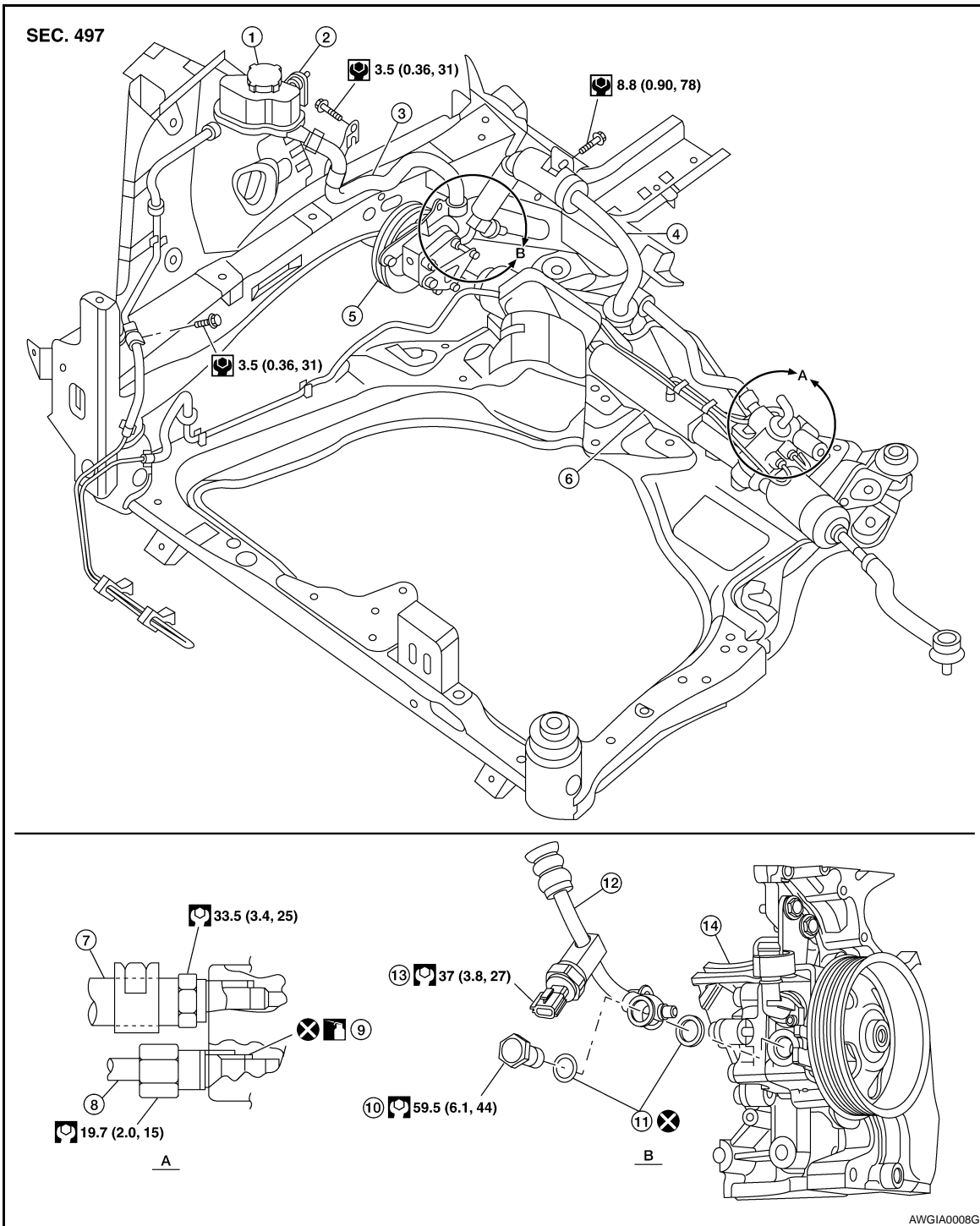

- | | | |
|------------------------|---|--|
| 1. Reservoir tank | 2. Reservoir tank bracket | 3. Suction hose |
| 4. High pressure hose | 5. Oil pump assembly | 6. Steering gear assembly |
| 7. Low pressure piping | 8. High pressure piping | 9. O-ring |
| 10. Eye-bolt | 11. Copper washer | 12. Eye-joint (assembled to high-pressure side hose) |
| 13. Pressure sensor | 14. Oil pump bracket to engine mounting point | Genuine Nissan PSF or equivalent |

VQ35DE : Removal and Installation

INFOID:000000001342156

REMOVAL

HYDRAULIC LINE

< ON-VEHICLE REPAIR >

Refer to [ST-22. "VQ35DE : Exploded View"](#) for removal procedure.

INSTALLATION

- Insert hose securely until it contacts tube spool.

CAUTION:

Do not apply fluid.

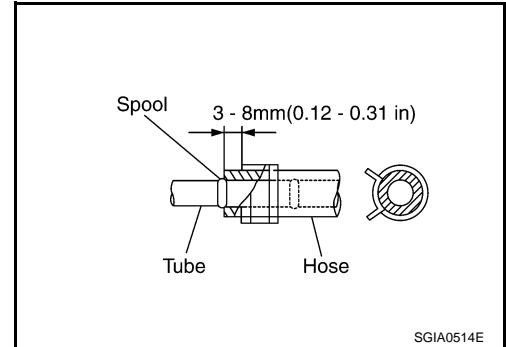

- Install eye-bolt with eye-joint (assembled to high-pressure hose) protrusion facing with pump side cutout, and then tighten it to the specified torque after tightening by hand.

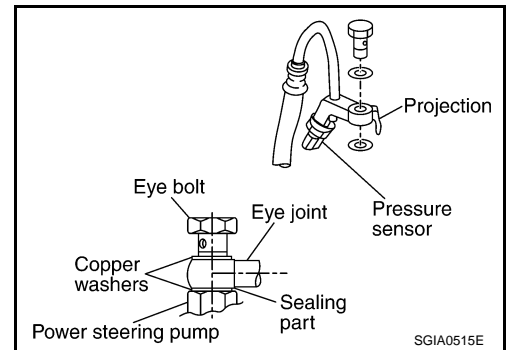

STEERING COLUMN

< DISASSEMBLY AND ASSEMBLY >

DISASSEMBLY AND ASSEMBLY

STEERING COLUMN

Disassembly and Assembly

INFOID:000000001342157

The steering column assembly is not serviceable and must be replaced as an assembly.

A

B

C

D

E

F

ST

H

I

J

K

L

M

N

O

P

STEERING GEAR AND LINKAGE

< DISASSEMBLY AND ASSEMBLY >

STEERING GEAR AND LINKAGE

Exploded View

INFOID:000000001342158

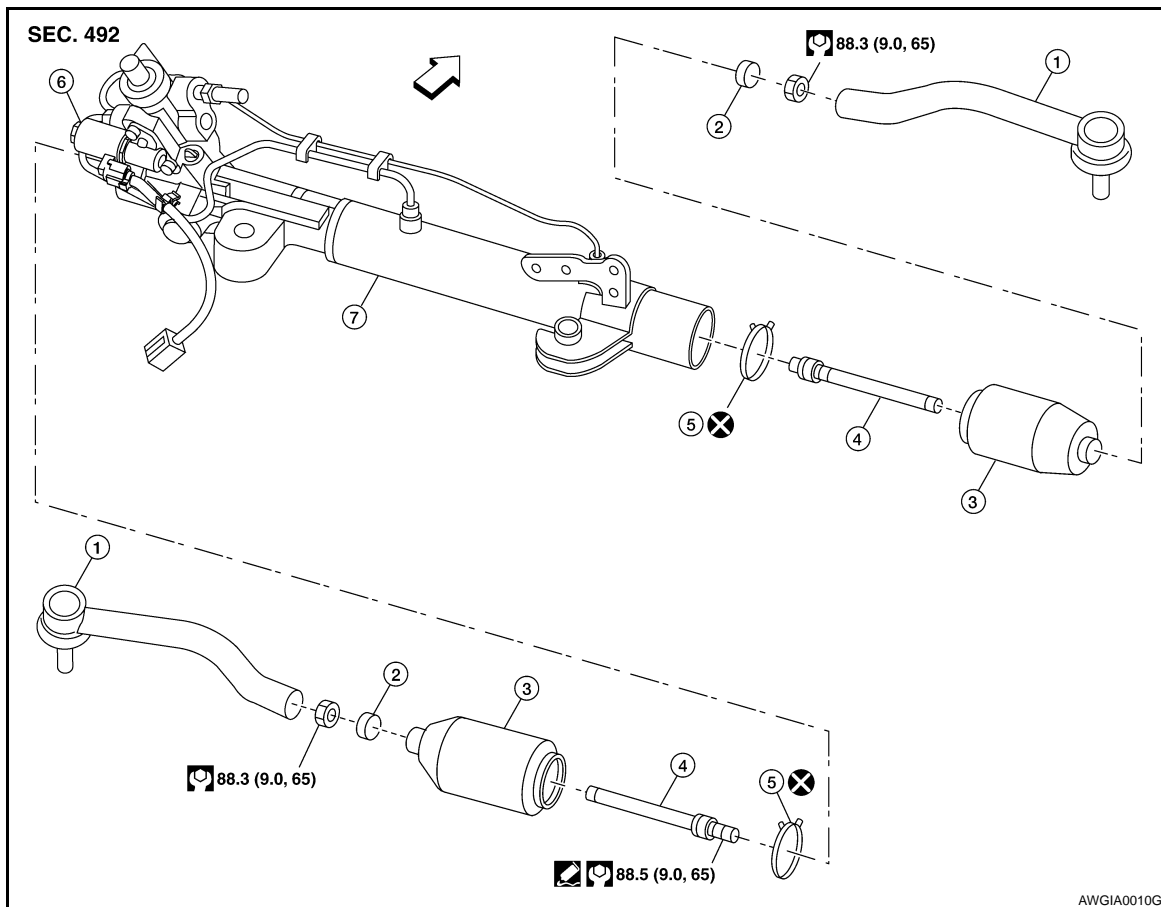

- | | | |
|------------------|---------------|---------------------------------------|
| 1. Outer socket | 2. Boot clamp | 3. Boot |
| 4. Inner socket | 5. Boot clamp | 6. SSPS valve (part of gear assembly) |
| 7. Gear assembly | ← Front | Three Bound TB1111 or equivalent |

Disassembly

INFOID:000000001342159

1. Remove outer socket locknut and outer socket
2. Remove boot clamps and boot.
3. Remove inner socket.

Inspection

INFOID:000000001342160

INSPECTION AFTER DISASSEMBLY

Boot

Check boot for cracks. Replace if there are.

Outer Socket and Inner Socket

1. Ball joint swinging torque

STEERING GEAR AND LINKAGE

< DISASSEMBLY AND ASSEMBLY >

- Hook a spring balance at the point shown in the figure and pull the spring balance. Make sure that the spring balance reads the specified value when ball stud and inner socket start to move. Replace outer socket and steering gear assembly if they are outside the standard.

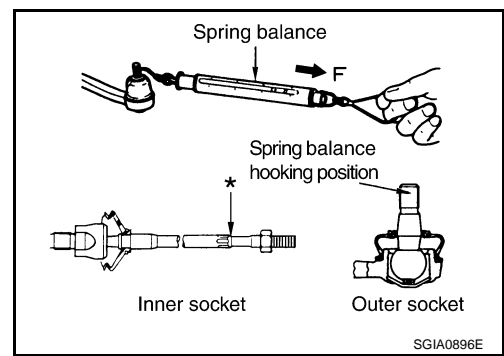

Items	Outer socket	Inner socket
Measuring point of spring balance	Stud cotter pin mounting hole	Measuring point at * mark shown in the figure
Swinging torque	0.1 - 2.9 N·m (0.01 - 0.29 kg-m, 1.0 - 25 in-lb)	0.1 - 7.8 N·m (0.01 - 0.79 kg-m, 1.0 - 69 in-lb)
Spring balance measurement	1.4 - 42.7 N (0.14 - 4.4 kg, 12 - 31 lb)	0.8 - 64 N (0.082 - 6.5 kg, 0.18 - 14.4 lb)

- Ball joint rotating torque
 - Make sure that the reading is within the following specified range using Tool. Replace outer socket if the reading is outside the specified value.

Tool number : ST3127S000 (J-25765-A)

Outer socket rotating torque	0.3 - 2.9 N·m (0.03 - 0.29 kg-m, 3.0 - 25 in-lb)
-------------------------------------	---

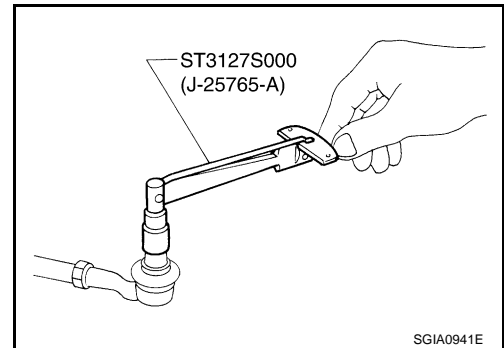

- Ball joint axial end play
 - Apply an axial load of 490 N (50 kg-f, 111 lb-f) to ball stud using a dial gauge. Measure amount of stud movement, and then make sure that the value is within the following specified range. Replace outer socket and inner socket if the measured value is outside the standard.

Outer socket	0.5 mm (0.020 in) or less
Inner socket	0.2 mm (0.008 in) or less

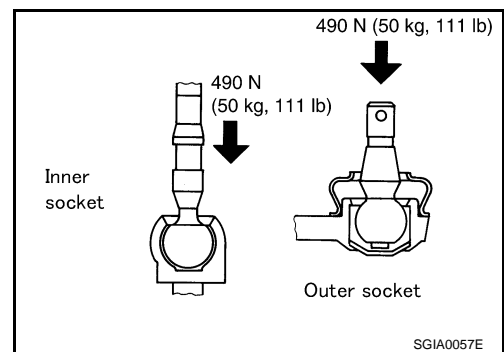

Assembly

INFOID:000000001342161

- Apply Three Bound TB1111 or equivalent to inner socket and turn pinion fully to left with inner socket installed to gear housing assembly.

STEERING GEAR AND LINKAGE

< DISASSEMBLY AND ASSEMBLY >

2. Install large end of boot to gear housing assembly.
3. Install small end of boot to inner socket boot mounting groove.

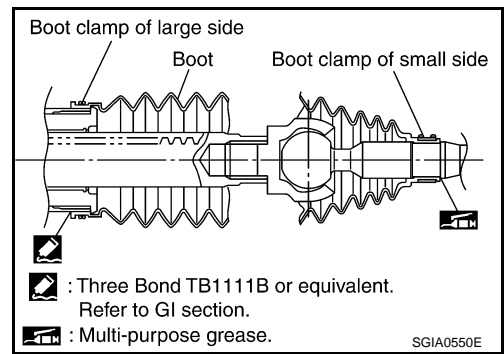

4. Install boot clamp to boot small end.
5. Install boot clamp to boot large end.

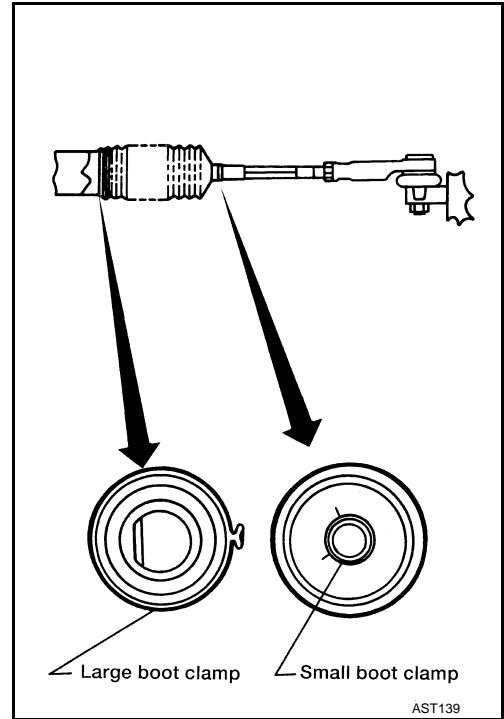

6. Adjust inner socket to standard length "L", and then tighten lock nut to the specified torque. Refer to [ST-26, "Exploded View"](#). Check length of inner socket "L" again after tightening lock nut. Make sure that the length is the standard.

Inner socket length "L"	93.3 mm (3.673 in)
--------------------------------	---------------------------

CAUTION:

Adjust toe-in after this procedure. Length achieved after toe-in adjustment should not be more than 98.3 mm max.

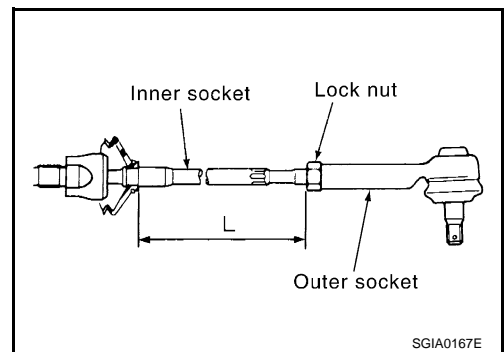

POWER STEERING OIL PUMP

< DISASSEMBLY AND ASSEMBLY >

POWER STEERING OIL PUMP

QR25DE

A

QR25DE : Disassembly and Assembly

INFOID:000000001342162

B

The power steering oil pump and pulley is not serviceable and should be replaced as an assembly. For front and rear bracket removal, refer to [ST-19, "QR25DE : Removal and Installation"](#).

VQ35DE

C

VQ35DE : Disassembly and Assembly

INFOID:000000001342163

D

The power steering oil pump and pulley is not serviceable and should be replaced as an assembly. For front and rear bracket removal, refer to [ST-20, "VQ35DE : Removal and Installation"](#).

E

F

ST

H

I

J

K

L

M

N

O

P

SERVICE DATA AND SPECIFICATIONS (SDS)

< SERVICE DATA AND SPECIFICATIONS (SDS)

SERVICE DATA AND SPECIFICATIONS (SDS)

SERVICE DATA AND SPECIFICATIONS (SDS)

Steering Wheel

INFOID:0000000001342164

Steering wheel axial end play	0 mm (0 in)
Steering wheel play	0 - 35 mm (0 - 1.38 in)

Steering Angle

INFOID:0000000001342165

Unit: Degree minute (Decimal Degree)

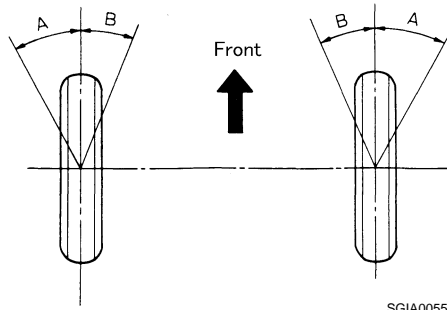

SGIA0055E

Tire size		P215/60R16	P215/55R17
Inner wheel (Angle: A)	Minimum	35° 30' (35.5°)	33° 30' (33.5°)
	Nominal	38° 30' (38.5°)	36° 30' (36.5°)
	Maximum	39° 30' (39.5°)	37° 30' (37.5°)
Outer wheel (Angle: B)	Nominal	31° (31.5°)	30° 30' (30.5°)

Steering Column

INFOID:0000000001342166

STEERING COLUMN LENGTH

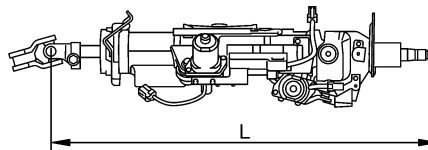

SGIA1177E

Steering column length "L"	Telescopic maximum	513 - 543 mm (20.20 - 21.38 in)
	Telescopic minimum	503 - 513 mm (19.80 - 20.20 in)

TILT MECHANISM OPERATING RANGE

SERVICE DATA AND SPECIFICATIONS (SDS)

< SERVICE DATA AND SPECIFICATIONS (SDS)

Unit: mm (in)

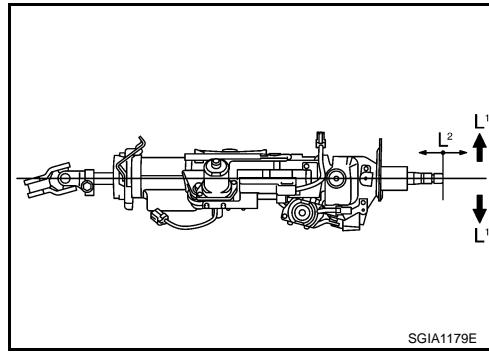

Tilt operating range "L ¹ "	41 (1.61)
Telescopic operating range "L ² "	40 (1.57)

Steering Gear

INFOID:000000001342167

STEERING OUTER SOCKET AND INNER SOCKET

Steering gear type		PR26AF
Outer socket	Swinging torque	0.1 - 2.9 N·m (0.01 - 0.29 kg-m, 1.0 - 25 in-lb)
	Measurement on spring balance Measuring point: cotter pin hole of stud	1.4 - 42.7 N (0.14 - 4.4 kg, 12 - 31 lb)
	Rotating torque	0.3 - 2.9 N·m (0.03 - 0.29 kg-m, 3.0 - 25 in-lb)
	Axial end play	0.5 mm (0.020 in) or less
Inner socket	Swinging torque	0.1 - 7.8 N·m (0.01 - 0.79 kg-m, 1.0 - 69 in-lb)
	• Measurement on spring balance • Measuring point at* mark shown	0.8 - 64 N (0.082 - 6.5 kg, 0.18 - 14.4 lb)
	Axial end play	0.2 mm (0.008 in) or less
Inner socket length "L"	Nominal	93.3 mm (3.673 in) 98.3 mm (3.870 in)
	Maximum	93.3 mm (3.673 in) 98.3 mm (3.870 in)

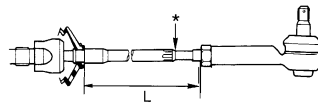

SGIA0950E

RACK STROKE

SERVICE DATA AND SPECIFICATIONS (SDS)

< SERVICE DATA AND SPECIFICATIONS (SDS)

Steering gear model	PR26AF	
Tire size	P215/60R16	P215/55R17
Rack neutral position, dimension "L" (rack stroke)	71.5 mm (2.815 in)	69.0 mm (2.717 in)

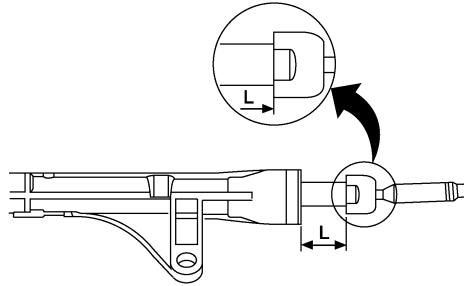

AWGIA0003GB

Oil Pump

INFOID:000000001342168

Oil pump relief hydraulic pressure	8,520 - 9,320 kPa (86.9 - 95.1 kg/cm ² , 1,235 - 1,351 psi)
------------------------------------	--

Steering Fluid

INFOID:000000001342169

Fluid type and capacity	Refer to MA-12. "Fluids and Lubricants" .
-------------------------	---