

A
LU
C

SECTION LU

ENGINE LUBRICATION SYSTEM

CONTENTS

QR25DE	Changing Engine Oil	9 F
PRECAUTION	OIL FILTER	10 G
PRECAUTIONS	Removal and Installation	10
Precautions For High-Voltage System	ON-VEHICLE REPAIR	11 H
Precaution for Liquid Gasket	OIL PUMP	11 I
PREPARATION	Removal and Installation	11
PREPARATION	Disassembly and Assembly	11
Special Service Tool	OIL COOLER	14 J
Commercial Service Tool	Removal and Installation	14
FUNCTION DIAGNOSIS	SERVICE DATA AND SPECIFICATIONS	15 K
LUBRICATION SYSTEM	(SDS)	15
Lubrication Circuit	SERVICE DATA AND SPECIFICATIONS	15 L
Schematic	(SDS)	15
ON-VEHICLE MAINTENANCE	Oil Pressure	15
ENGINE OIL	Oil Pump	15
Inspection	Regulator Valve	15
	Oil Capacity	15
		M
		N
		O
		P

PRECAUTION

PRECAUTIONS

Precautions For High-Voltage System

INFOID:000000001501601

Refer to [GI-24, "Precautions For High-Voltage System"](#).

Precaution for Liquid Gasket

INFOID:000000001501602

REMOVAL OF LIQUID GASKET SEALING

- After removing nuts and bolts, separate the mating surface, using Tool and remove old liquid gasket sealing.

Tool number : KV10111100 (J-37228)

CAUTION:

Be careful not to damage the mating surfaces.

- Tap Tool to insert it, and then slide it by tapping on the side as shown.
- In areas where Tool is difficult to use, use plastic hammer to lightly tap the parts, to remove it.

CAUTION:

If for some unavoidable reason suitable tool such as screw-driver is used, be careful not to damage the mating surfaces.

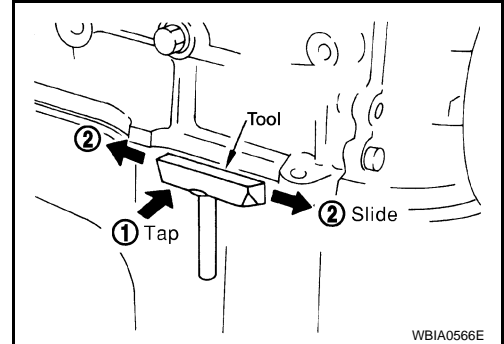

LIQUID GASKET APPLICATION PROCEDURE

1. Remove old liquid gasket adhering to the liquid gasket application surface and the mating surface, Using scraper.
 - Remove liquid gasket completely from the groove of the liquid gasket application surface, bolts, and bolt holes.
2. Thoroughly clean the mating surfaces and remove adhering moisture, grease and foreign materials.

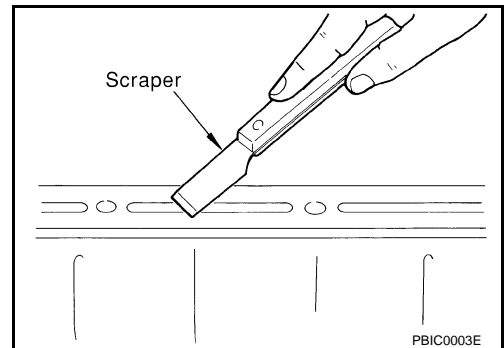

3. Attach liquid gasket tube to Tool.

Tool number : WS39930000 (—)

Use Genuine RTV Silicone Sealant or equivalent. Refer to [GI-15, "Recommended Chemical Products and Sealants"](#).

4. Apply liquid gasket without breaks to the specified location with the specified dimensions.
 - If there is a groove for the liquid gasket application, apply liquid gasket to the groove.

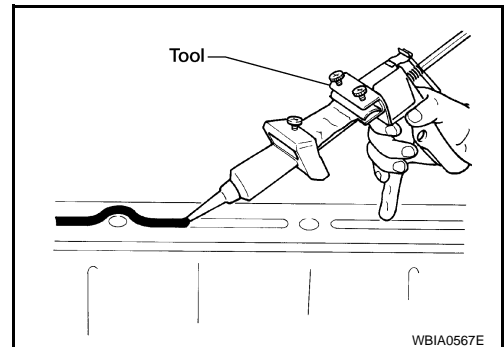

PRECAUTIONS

[QR25DE]

< PRECAUTION >

- As for the bolt holes, normally apply liquid gasket inside the holes. Occasionally, it should be applied outside the holes. Make sure to read the text of service manual.
- Within five minutes of liquid gasket application, install the mating component.
- If liquid gasket protrudes, wipe it off immediately.
- Do not retighten nuts or bolts after the installation.
- After 30 minutes or more have passed from the installation, fill engine oil and engine coolant.

CAUTION:

If there are specific instructions in this manual, observe them.

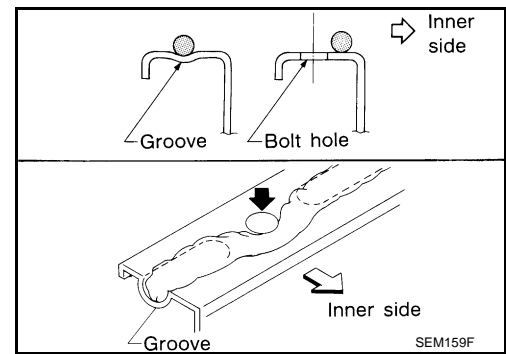

A

LU

C

D

E

F

G

H

I

J

K

L

M

N

O

P

PREPARATION

< PREPARATION >

[QR25DE]

PREPARATION

PREPARATION

Special Service Tool

INFOID:000000001501603

The actual shape of the Kent-Moore tools may differ from those tools illustrated here.

Tool number (Kent Moore No.) Tool name	Description
ST25051001 (J-25695-1) Oil pressure gauge	Measuring oil pressure Maximum measuring range: 2,452 kPa (25 kg/cm², 356 psi)
ST25052000 (J-25695-2) Hose	Adapting oil pressure gauge to cylinder block
KV10115801 (J-38956) Oil filter wrench	Removing and installing oil filter
KV10111100 (J-37228) Seal cutter	Removing steel oil pan and rear timing chain case
WS39930000 (—) Tube presser	Pressing the tube of liquid gasket

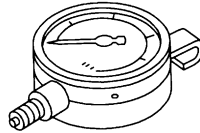

S-NT050

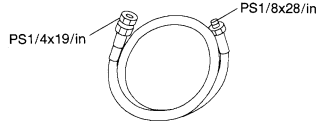

S-NT559

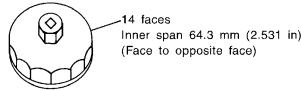

S-NT772

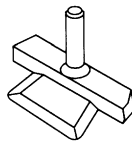

S-NT046

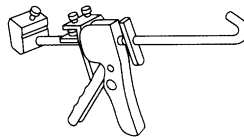

S-NT052

Commercial Service Tool

INFOID:000000001501604

PREPARATION

< PREPARATION >

[QR25DE]

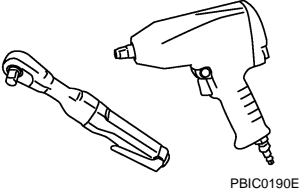
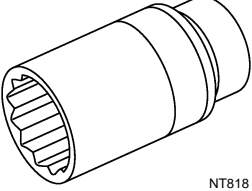
Tool name	Description
<p>Power tool</p>  <p style="text-align: right;">FBIC0190E</p>	<p>Loosening bolts and nuts</p>
<p>Deep socket</p>  <p style="text-align: right;">NT818</p>	<p>Removing and installing oil pressure sensor Deep socket 26 mm, 3/8 drive</p>

A

LU

C

D

E

F

G

H

I

J

K

L

M

N

O

P

LUBRICATION SYSTEM

< FUNCTION DIAGNOSIS >

[QR25DE]

FUNCTION DIAGNOSIS

LUBRICATION SYSTEM

Lubrication Circuit

INFOID:000000001501605

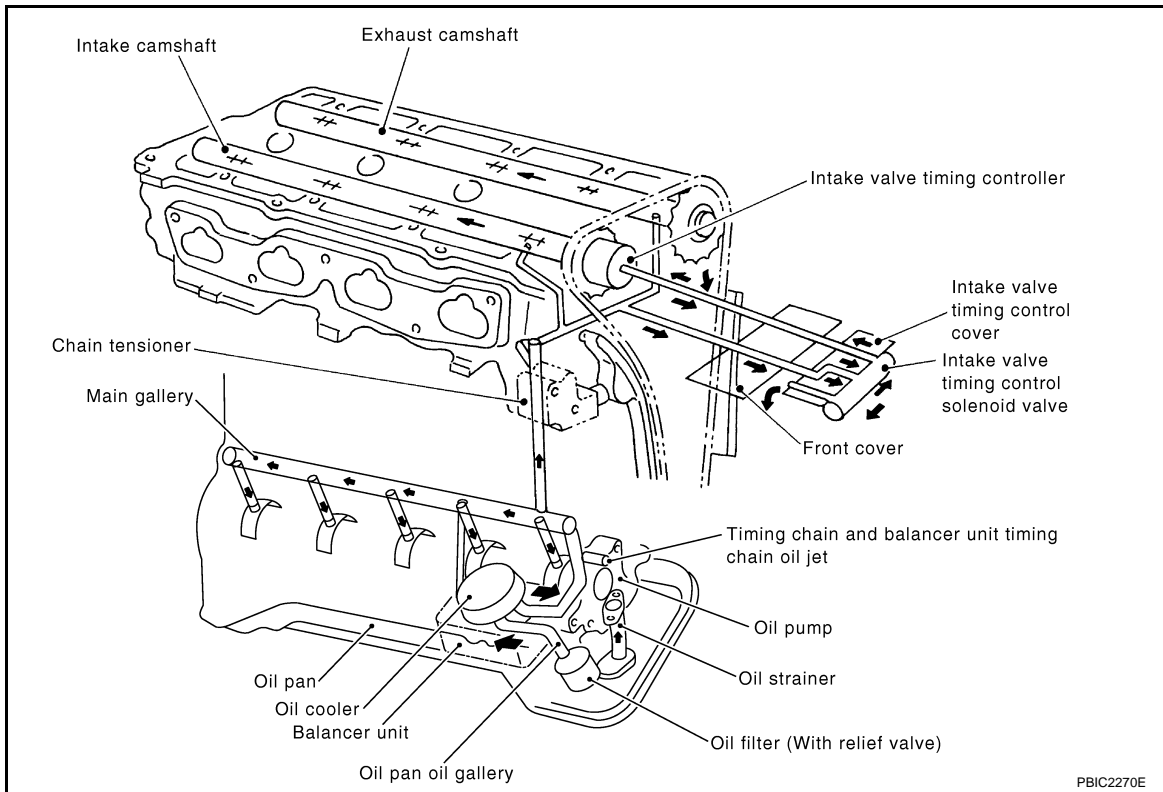

Schematic

INFOID:000000001501606

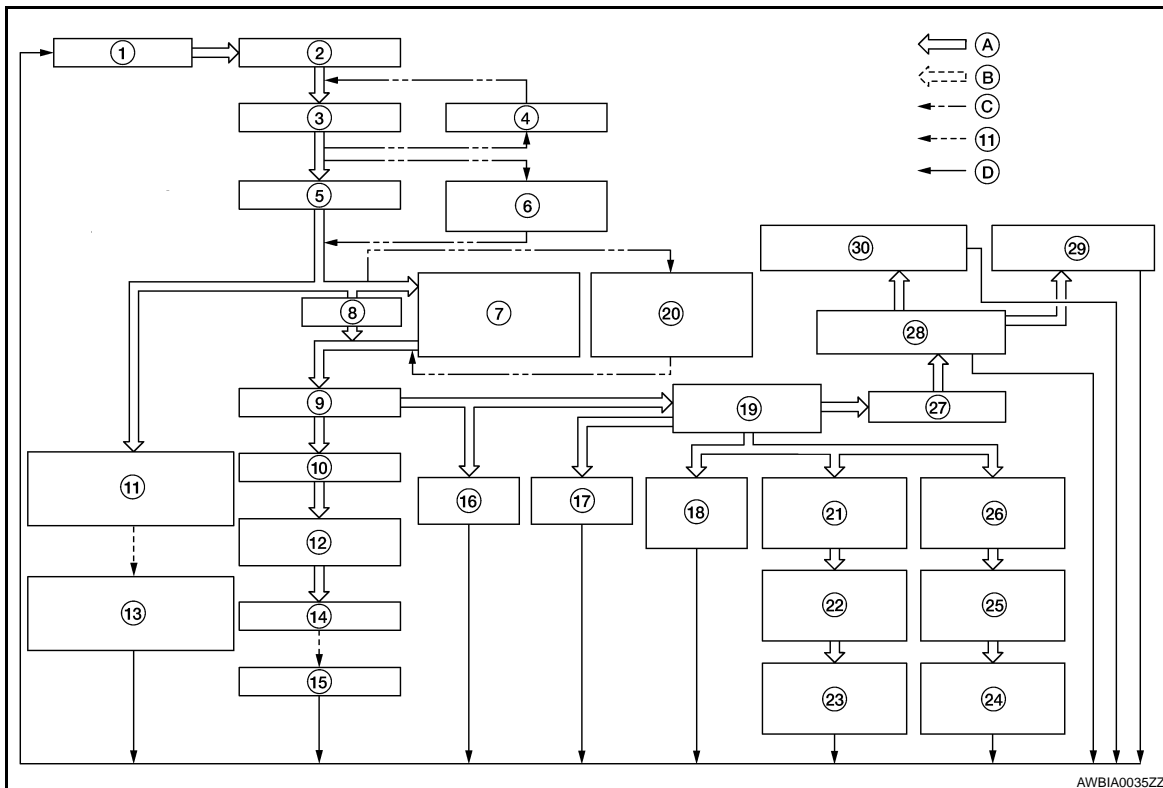

LUBRICATION SYSTEM

< FUNCTION DIAGNOSIS >

[QR25DE]

- | | | | |
|---|---|--|----|
| 1. Oil pan | 2. Oil strainer | 3. Oil pump | A |
| 4. Regulator valve | 5. Oil filter | 6. Relief valve (Built in oil filter) | |
| 7. Oil cooler | 8. Bypass | 9. Main gallery | |
| 10. Main bearing | 11. Timing chain and balancer unit timing chain oil jet | 12. Connecting rod bearing | LU |
| 13. Timing chain and balancer unit timing chain | 14. Connecting rod | 15. Piston | |
| 16. Balancer unit | 17. Chain tensioner | 18. Camshaft bracket (No.1) | C |
| 19. Cylinder head oil gallery | 20. Relief valve | 21. Intake camshaft bracket (No.2) | |
| 22. Intake camshaft oil passage | 23. Intake camshaft journal | 24. Exhaust camshaft journal | D |
| 25. Exhaust camshaft oil passage | 26. Exhaust camshaft bracket (No.2) | 27. Front cover | |
| 28. Intake valve timing control cover | 29. Intake valve timing controller | 30. Intake valve timing control solenoid valve | E |
| A. Oil passage | B. Return oil passage | C. Bypass | |
| D. To oil pan | | | F |
| | | | G |
| | | | H |
| | | | I |
| | | | J |
| | | | K |
| | | | L |
| | | | M |
| | | | N |
| | | | O |
| | | | P |

ON-VEHICLE MAINTENANCE

ENGINE OIL

Inspection

INFOID:000000001501607

OIL LEVEL

- Before turning the Hybrid System, check the oil level. If the Hybrid System is already ON, turn OFF the Hybrid System and allow 10 minutes before checking.
- Check that the oil level is within the range on the dipstick.
- If it is out of range, add oil as necessary. Refer to [LU-8. "Inspection"](#).

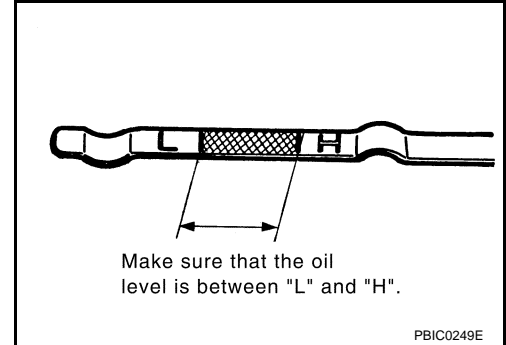

ENGINE OIL APPEARANCE

- Check engine oil for white milky or excessive contamination.
- If engine oil becomes milky, it is highly probable that it is contaminated with engine coolant. Repair or replace damaged parts.

OIL LEAKAGE

Check for oil leakage around the following areas:

- Oil pan
- Oil pan drain plug
- Oil pressure switch
- Oil filter
- IVTC cover
- Front cover
- Mating surface between cylinder block and cylinder head
- Mating surface between cylinder head and rocker cover
- Crankshaft oil seal

OIL PRESSURE CHECK

WARNING:

- **Be careful not to burn yourself, as engine oil may be hot.**
- **For CVT models, put the selector lever in the Park "P" position.**

1. Check engine oil level. Refer to [LU-8. "Inspection"](#).
2. Remove undercover using power tool.
3. Disconnect oil pressure switch harness connector at oil pressure switch, and remove oil pressure switch.

CAUTION:

Do not drop or shock oil pressure switch.

4. Turn Hybrid System ON and warm the engine up to normal operating temperature.
5. Check oil pressure with Hybrid System ON and engine running under no-load, using Tool

Tool numbers : **ST25051001 (J-25695-1)**
 : **ST25052000 (J-25695-2)**

NOTE:

When engine oil temperature is low, engine oil pressure becomes high.

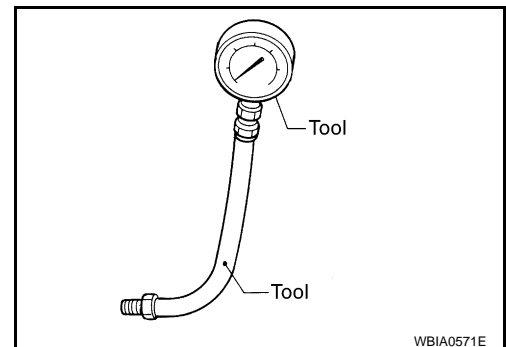

ENGINE OIL

< ON-VEHICLE MAINTENANCE >

[QR25DE]

Engine oil pressure [Oil temperature 80 °C (176 °F)]			
Engine speed (rpm)	Idle speed	2,000	6,000
Engine pressure kPa (kg/cm ² , psi)	Approx. 98 (1.0, 14) or more	Approx. 294 (3.0, 43) or more	Approx. 392 (4.0, 57) or more

If difference is extreme, check oil passage and oil pump for oil leaks.

6. After the inspections, install oil pressure switch as follows:
 - a. Remove old liquid gasket adhering to oil pressure switch and engine.
 - b. Apply liquid gasket and tighten oil pressure switch to the specification.
Use Genuine RTV Silicone Sealant or equivalent. Refer to [GI-15. "Recommended Chemical Products and Sealants"](#).

Oil pressure switch torque : 14.8 N·m (1.5 kg·m, 11 ft·lb)

- c. With the Hybrid System ON and after warming up engine, make sure there is no leakage of engine oil with running engine.

Changing Engine Oil

INFOID:000000001501608

WARNING:

- **Be careful not to burn yourself, as the engine oil may be hot.**
 - **Prolonged and repeated contact with used engine oil may cause skin cancer: try to avoid direct skin contact with used oil. If skin contact is made, wash thoroughly with soap or hand cleaner as soon as possible.**
1. Position the vehicle so it is level on the hoist.
 2. Turn Hybrid System ON and warm up the engine, and check for oil leaks from the engine.
 3. Turn Hybrid System OFF and wait for 10 minutes.
 4. Remove the oil pan drain plug and oil filler cap.
 5. Drain the engine oil.
 6. Install the oil pan drain plug with a new washer and refill the engine with new engine oil.
 - Oil specification and viscosity. Refer to [MA-10. "Fluids and Lubricants"](#).

Oil Capacity (Approximate)

Drain and refill	With oil filter change	4.6 ℓ (4 7/8 US qt, 4 Imp qt)
	Without oil filter change	4.3 ℓ (4 1/2 US qt, 3 3/4 Imp qt)
Dry engine (engine overhaul)		5.4 ℓ (5 3/4 US qt, 4 3/4 Imp qt)

CAUTION:

- **Be sure to clean the drain plug and install using a new washer.**

Oil pan drain plug : 34.3 N·m (3.5 kg·m, 25 ft·lb)

- **The refill capacity depends on the oil temperature and drain time. Use these specifications for reference only. Always use the dipstick to determine when the proper amount of oil is in the engine.**
7. Turn Hybrid System ON and warm up the engine and check the area around the drain plug and oil filter for oil leakage.
 8. Turn the Hybrid System OFF and wait for 10 minutes.
 9. Check the oil level using the dipstick.

CAUTION:

Do not overfill the engine oil.

OIL FILTER

Removal and Installation

INFOID:000000001501609

REMOVAL

1. Remove the oil filter using Tool.

Tool number : KV10115801 (J-38956)

CAUTION:

- Be careful not to get burned when the engine and engine oil are hot.
- When removing, prepare a shop cloth to absorb any oil leakage or spillage.
- Do not allow engine oil to adhere to the drive belts.
- Completely wipe off any oil that adheres to the engine and the vehicle.

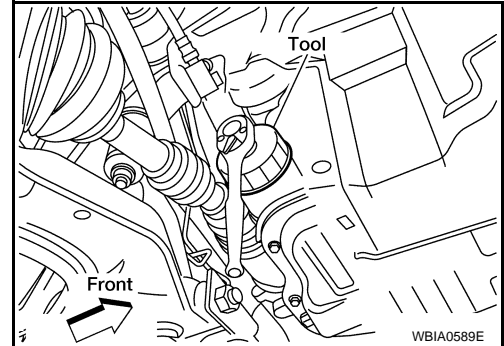

- The oil filter has a built in pressure relief valve. Use a genuine NISSAN oil filter or equivalent

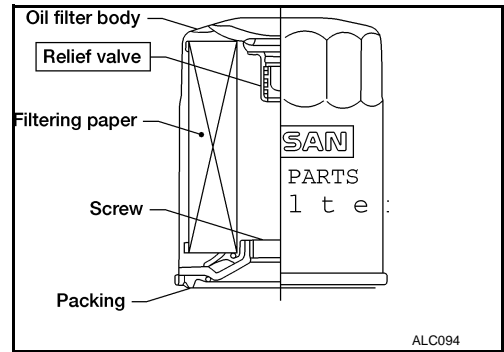

INSTALLATION

1. Clean off any foreign materials adhering to the oil filter installation surface.
2. Apply engine oil to the oil seal surface of the new oil filter.

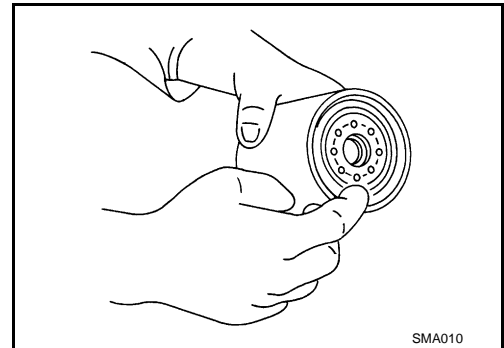

3. Screw the oil filter manually until it touches the installation surface, then tighten it by 2/3 turn. Or tighten to specification below.

Oil filter : 17.6 N·m (1.8 kg·m, 13 ft·lb)

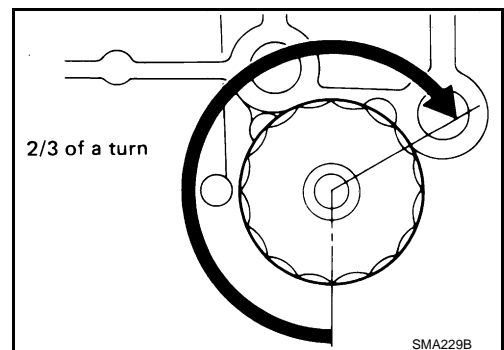

4. Check oil level and add engine oil as necessary. Refer to [LU-8. "Inspection"](#).
5. Turn the Hybrid System ON and after warming up the engine, check for oil leaks.

ON-VEHICLE REPAIR

OIL PUMP

Removal and Installation

INFOID:000000001501610

- Remove the front cover. Refer to [EM-50, "Removal and Installation"](#).

Disassembly and Assembly

INFOID:000000001501611

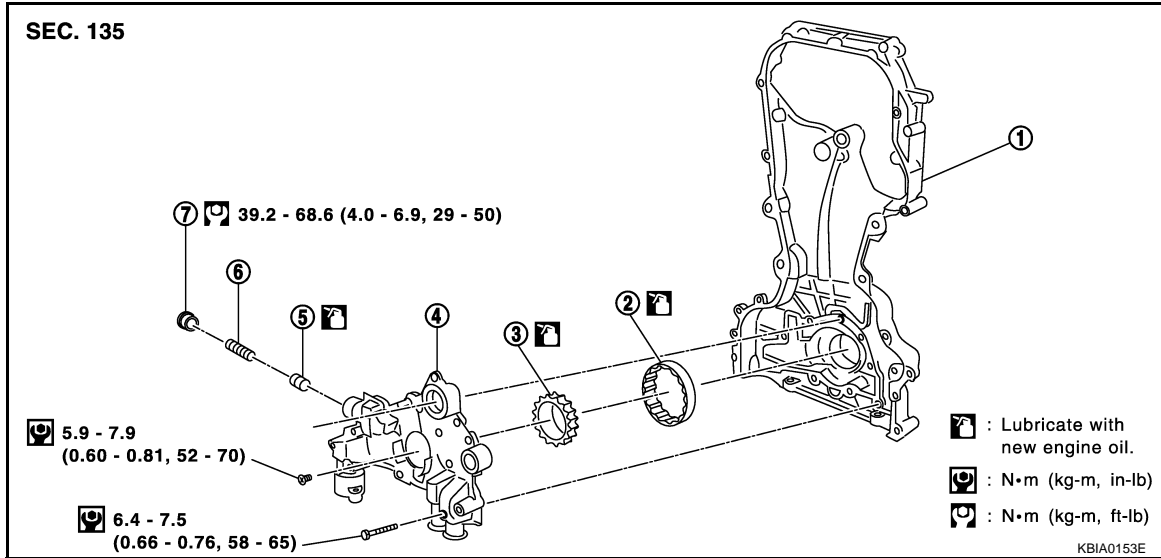

- | | | |
|-------------------|--------------------|----------------|
| 1. Front cover | 2. Outer rotor | 3. Inner rotor |
| 4. Oil pump cover | 5. Regulator valve | 6. Spring |
| 7. Regulator plug | | |

CAUTION:

Before installation, apply new engine oil to the parts as instructed in the figure above.

DISASSEMBLY

1. Remove the oil pump cover.
2. Remove inner rotor and outer rotor from front cover.
3. After removing regulator plug, remove regulator spring and regulator valve.

INSPECTION AFTER DISASSEMBLY

Measure the clearance of the oil pump parts.

- Measure clearance with feeler gauge.
- Clearance between outer rotor and oil pump body (position 1).

Standard : 0.114 - 0.179 mm (0.0045 - 0.0070 in)

- Tip clearance between inner rotor and outer rotor (position 2).

Standard : 0.170 - 0.220 mm (0.0067 - 0.0087 in)

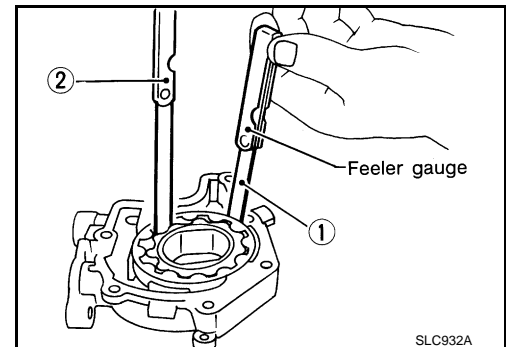

OIL PUMP

[QR25DE]

< ON-VEHICLE REPAIR >

- Measure clearance with feeler gauge and straightedge.
- Side clearance between inner rotor and oil pump body (position 3).

Standard : 0.030 - 0.070 mm (0.0012 - 0.0028 in)

- Side clearance between outer rotor and oil pump body (position 4).

Standard : 0.060 - 0.110 mm (0.0024 - 0.0043 in)

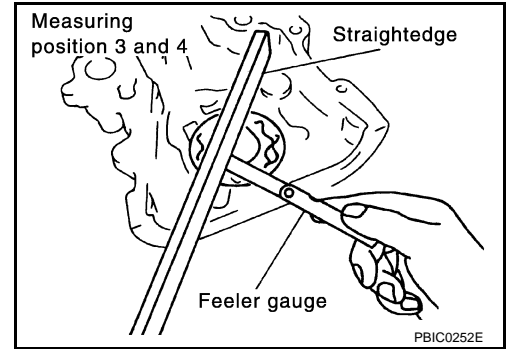

- Calculate the clearance between inner rotor and oil pump body as follows:

1. Measure the outer diameter of protruded portion of inner rotor (Position 5).

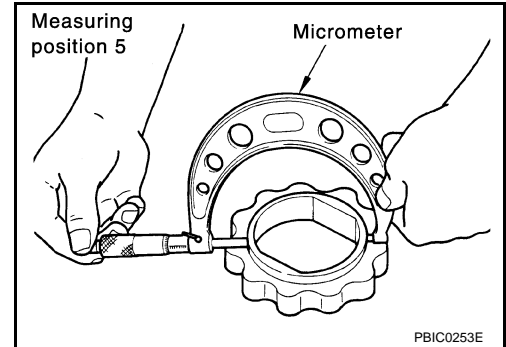

2. Measure the inner diameter of oil pump body with inside micrometer (Position 6).
(Clearance) = (Inner diameter of oil pump body) – (Outer diameter of inner rotor).

Standard : 0.035 - 0.070 mm (0.0014 - 0.0028 in)

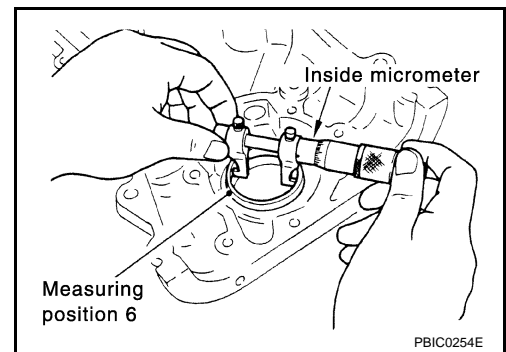

- Regulator valve clearance:
(Clearance) = D1 (Valve hole diameter) – D2 (Outer diameter of valve)

Standard : 0.040 - 0.097 mm (0.0016 - 0.0038 in)

CAUTION:

Coat regulator valve with engine oil.

Check that it falls smoothly into the valve hole by its own weight.

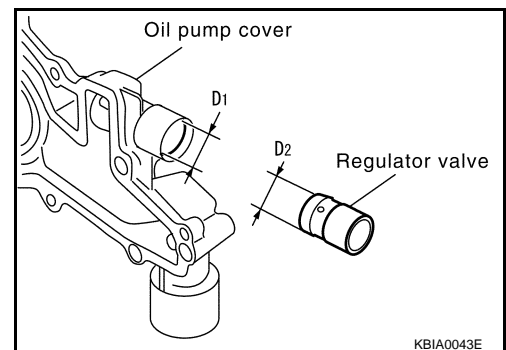

ASSEMBLY

OIL PUMP

[QR25DE]

< ON-VEHICLE REPAIR >

- Assembly is in the reverse order of disassembly.
- Install the inner rotor and outer rotor with the punched marks on the oil pump cover side.

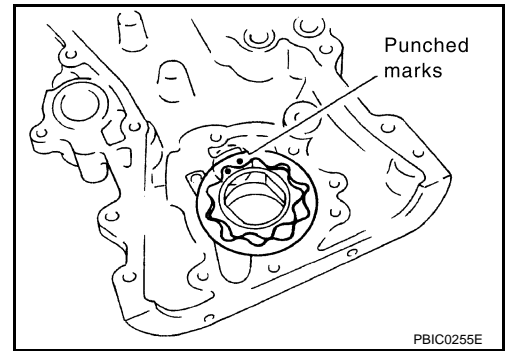

A

LU

C

D

E

F

G

H

I

J

K

L

M

N

O

P

OIL COOLER

Removal and Installation

INFOID:000000001501612

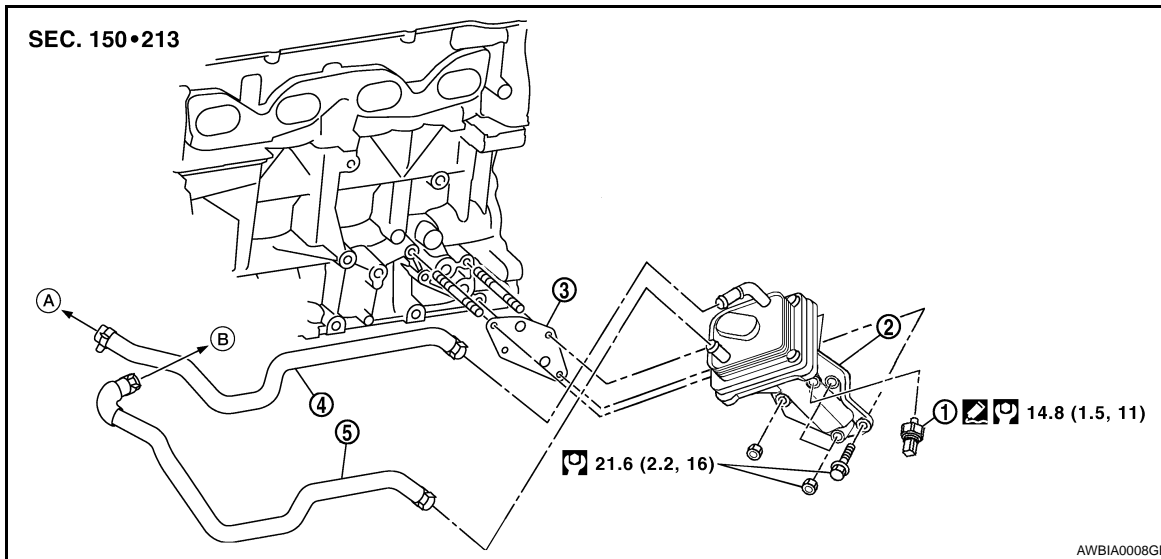

- | | | |
|------------------------|---------------|-----------|
| 1. Oil pressure sensor | 2. Oil cooler | 3. Gasket |
| 4. Water hose | 5. Water hose | |

WARNING:

Be careful not to get burned when engine coolant and engine oil may be hot.

CAUTION:

- When removing the oil cooler, use a shop cloth to absorb any engine oil leaks or spills.
- Completely wipe off any engine oil that adheres to the engine and the vehicle.

REMOVAL

1. Drain engine oil. Refer to [LU-9, "Changing Engine Oil"](#).
2. Drain engine coolant. Refer to [CO-11, "Changing Engine Coolant"](#).

CAUTION:

Do not spill coolant on the drive belt.

3. Disconnect water hoses from oil cooler.

NOTE:

For reference when installing, put matching mark on oil cooler.

4. Remove oil cooler.

INSPECTION AFTER REMOVAL

1. Check oil cooler for cracks.
2. Check oil cooler for clogging by blowing through coolant inlet. If necessary, replace oil cooler assembly.

INSTALLATION

Installation is in reverse order of removal.

INSPECTION AFTER INSTALLATION

Turn the Hybrid System ON and start engine. Check that there are no engine oil or coolant leaks.

SERVICE DATA AND SPECIFICATIONS (SDS)

< SERVICE DATA AND SPECIFICATIONS (SDS)

[QR25DE]

SERVICE DATA AND SPECIFICATIONS (SDS)

SERVICE DATA AND SPECIFICATIONS (SDS)

Oil Pressure

INFOID:000000001501613

LU

Engine speed rpm	Approximate discharge pressure kPa (kg/cm ² , psi)
Idle speed	More than 98 (1.0, 14)
2,000	294 (3.0, 43)
6,000	392 (4.0, 57)

Oil Pump

INFOID:000000001501614

Unit: mm (in)

Body to outer rotor radial clearance	0.114 - 0.179 (0.0045 - 0.0070)
Inner rotor to outer rotor tip clearance	0.170 - 0.220 (0.0067 - 0.0087)
Body to inner rotor axial clearance	0.030 - 0.070 (0.0012 - 0.0028)
Body to outer rotor axial clearance	0.060 - 0.110 (0.0024 - 0.0043)
Inner rotor to brazed portion of housing clearance	0.035 - 0.070 (0.0014 - 0.0028)

Regulator Valve

INFOID:000000001501615

Unit: mm (in)

Regulator valve to oil pump cover clearance	0.040 - 0.097 (0.0016 - 0.0038)
---	---------------------------------

Oil Capacity

INFOID:000000001501616

Unit: ℓ (US qt, Imp qt)

Drain and refill	With oil filter change	Approximately 4.6 (4 7/8, 4)
	Without oil filter change	Approximately 4.3 (4 1/2, 3 3/4)
Dry engine (engine overhaul)		Approximately 5.4 (5 3/4, 4 3/4)