

SECTION **FSU**
FRONT SUSPENSION

A
B
C
D
E
F
G
H
I
J
K
L
M
N
O
P

FSU

CONTENTS

SYMPTOM DIAGNOSIS	2	FRONT COIL SPRING AND STRUT	8	F
NOISE, VIBRATION AND HARSHNESS (NVH) TROUBLESHOOTING	2	Removal and Installation	8	
NVH Troubleshooting Chart	2	Disassembly and Assembly	8	
PRECAUTION	3	Inspection	9	G
PRECAUTIONS	3	TRANSVERSE LINK	11	
Precaution for Supplemental Restraint System (SRS) "AIR BAG" and "SEAT BELT PRE-TENSIONER"	3	Removal and Installation	11	H
Service Notice or Precautions	3	FRONT STABILIZER	12	
PREPARATION	4	Removal and Installation	12	I
PREPARATION	4	REMOVAL AND INSTALLATION	13	
Special Service Tool	4	FRONT SUSPENSION ASSEMBLY	13	J
Commercial Service Tool	5	Exploded View	13	
ON-VEHICLE MAINTENANCE	6	Removal and Installation	14	
FRONT SUSPENSION ASSEMBLY	6	SERVICE DATA AND SPECIFICATIONS (SDS)	15	K
Inspection and Adjustment	6	SERVICE DATA AND SPECIFICATIONS (SDS)	15	L
ON-VEHICLE REPAIR	8	Wheel Alignment	15	
		Ball Joint	15	M
		Wheel Height	16	

NOISE, VIBRATION AND HARSHNESS (NVH) TROUBLESHOOTING

< SYMPTOM DIAGNOSIS >

SYMPTOM DIAGNOSIS

NOISE, VIBRATION AND HARSHNESS (NVH) TROUBLESHOOTING

NVH Troubleshooting Chart

INFOID:000000001503437

Use the chart below to help you find the cause of the symptom. If necessary, repair or replace these parts.

Reference page		FSU-13	FSU-9	—	—	—	FSU-13	FSU-6	FSU-6	WT-29, "NVH Troubleshooting Chart"	WT-29, "NVH Troubleshooting Chart"	FAX-2, "NVH Troubleshooting Chart"	BR-3, "NVH Troubleshooting Chart"	ST-2, "NVH Troubleshooting Chart"
Possible cause and SUSPECTED PARTS		Improper installation, looseness	Shock absorber deformation, damage or deflection	Bushing or mounting deterioration	Parts interference	Spring fatigue	Suspension looseness	Incorrect wheel alignment	Stabilizer bar fatigue	TIRES	ROAD WHEEL	DRIVE SHAFT AND WHEEL HUB	BRAKES	STEERING
Symptom	Noise	x	x	x	x	x	x			x	x	x	x	x
	Shake	x	x	x	x		x			x	x	x	x	x
	Vibration	x	x	x	x	x				x		x		x
	Shimmy	x	x	x	x			x		x	x		x	x
	Shudder	x	x	x						x	x		x	x
	Poor quality ride or handling	x	x	x	x	x		x	x	x	x			

x: Applicable

PRECAUTIONS

< PRECAUTION >

PRECAUTION

PRECAUTIONS

Precaution for Supplemental Restraint System (SRS) "AIR BAG" and "SEAT BELT PRE-TENSIONER"

INFOID:000000001503438

The Supplemental Restraint System such as "AIR BAG" and "SEAT BELT PRE-TENSIONER", used along with a front seat belt, helps to reduce the risk or severity of injury to the driver and front passenger for certain types of collision. This system includes seat belt switch inputs and dual stage front air bag modules. The SRS system uses the seat belt switches to determine the front air bag deployment, and may only deploy one front air bag, depending on the severity of a collision and whether the front occupants are belted or unbelted. Information necessary to service the system safely is included in the SRS and SB section of this Service Manual.

WARNING:

- To avoid rendering the SRS inoperative, which could increase the risk of personal injury or death in the event of a collision which would result in air bag inflation, all maintenance must be performed by an authorized NISSAN/INFINITI dealer.
- Improper maintenance, including incorrect removal and installation of the SRS, can lead to personal injury caused by unintentional activation of the system. For removal of Spiral Cable and Air Bag Module, see the SRS section.
- Do not use electrical test equipment on any circuit related to the SRS unless instructed to in this Service Manual. SRS wiring harnesses can be identified by yellow and/or orange harnesses or harness connectors.

Service Notice or Precautions

INFOID:000000001503439

- When installing rubber bushings, the final tightening must be carried out under unladen conditions with tires on ground. Oil might shorten the life of rubber bushings. Be sure to wipe off any spilled oil.
- Unladen conditions mean that fuel, engine coolant and lubricant are full. Spare tire, jack, hand tools and mats are in designated positions.
- After servicing suspension parts, be sure to check wheel alignment.
- Self-lock nuts are not reusable. Always use new ones when installing. Since new self-lock nuts are pre-oiled, tighten as they are.

PREPARATION

< PREPARATION >

PREPARATION

PREPARATION

Special Service Tool

INFOID:000000001503440

The actual shapes of the Kent-Moore tools may differ from those of special service tools illustrated here.

Tool number (Kent-Moore No.) Tool name	Description
HT7252000 (J-25730-A) Ball joint remover	Removing tie-rod outer and lower ball joint
ST3127S000 (J-25765-A) Preload gauge	Measuring ball joint sliding torque
KV991040S1 (—) CCK gauge attachment <ol style="list-style-type: none"> 1. KV99104020 Adapter A 2. KV99104030 Adapter B 3. KV99104040 Adapter C 4. KV99104050 Adapter D 5. KV99104060 Plate 6. KV99104070 Guide bolt 7. KV99104080 Spring 8. KV99104090 Center plate 	Measuring wheel alignment
ST35652000 (—) Strut attachment	Disassembling and assembling strut
KV101J0010 (J-47242) Engine support table	Front suspension member removal

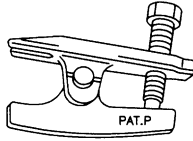

S-NT146

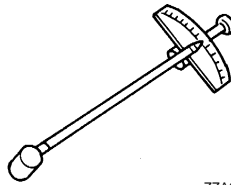

ZZA0806D

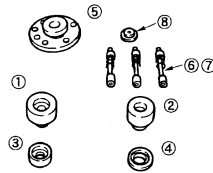

ZZA1167D

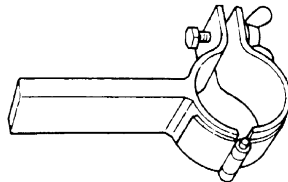

ZZA0807D

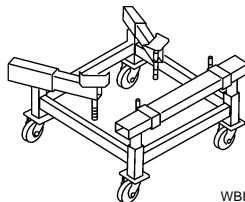



WBIA0658E

PREPARATION

< PREPARATION >

Commercial Service Tool

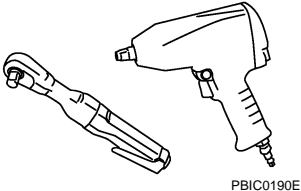
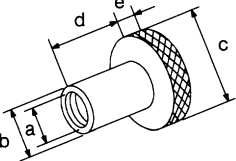
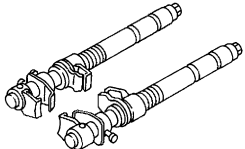
INFOID:000000001503441

Tool name	Description
<p>Power tool</p>  <p>PBIC0190E</p>	<p>Loosening bolts and nuts</p>
<p>Attachment wheel alignment</p> <p>a: screw M24 x 1.5 pitch b: 35 mm (1.38 in) dia. c: 65 mm (2.56 in) dia. d: 56 mm (2.20 in) dia. e: 12 mm (0.47 in) dia.</p>  <p>NT148</p>	<p>Measure wheel alignment</p>
<p>Spring compressor</p>  <p>NT717</p>	<p>Removing and installing coil spring</p>
<p>Engine slinger</p>  <p>LEIA0062E</p>	<p>Removing and installing suspension member with VQ35DE and CVT</p>

A
B
C
D
E
F
G
H
I
J
K
L
M
N
O
P

FSU

FRONT SUSPENSION ASSEMBLY

< ON-VEHICLE MAINTENANCE >

ON-VEHICLE MAINTENANCE

FRONT SUSPENSION ASSEMBLY

Inspection and Adjustment

INFOID:000000001503442

INSPECTION

Make sure the mounting conditions (looseness, back lash) of each component and component conditions (wear, damage) are normal.

LOWER BALL JOINT END PLAY

1. Set front wheels in a straight-ahead position. Do not depress brake pedal.
2. Place an iron bar or similar tool between upper link and steering knuckle.
3. Measure axial end play by prying it up and down. Refer to [FSU-15, "Ball Joint"](#).

CAUTION:

Be careful not to damage ball joint boot. Do not damage the installation position by applying excessive force.

SHOCK ABSORBER

Check for oil leakage, damage and replace if malfunction is detected.

WHEEL ALIGNMENT

Description

Measure wheel alignment under unladen conditions.

NOTE:

"Unladen conditions" means that fuel, engine coolant, and lubricant are full. Spare tire, jack, hand tools and mats are in designated positions.

General Information and Recommendations

- A four-wheel thrust alignment should be performed.
- This type of alignment is recommended for any NISSAN vehicle.
- The four-wheel "thrust" process helps ensure that the vehicle is properly aligned and the steering wheel is centered.
- The alignment rack itself should be capable of accepting any NISSAN vehicle.
- The rack should be checked to ensure that it is level.
- Make sure the machine is properly calibrated.
- Your alignment equipment should be regularly calibrated in order to give correct information.
- Check with the manufacturer of your specific equipment for their recommended Service/Calibration Schedule.

Preliminary Check

Check the following:

1. Tires for improper air pressure and wear.
2. Road wheels for runout. Refer to [WT-38, "Road Wheel"](#).
3. Wheel bearing axial end play. Refer to [FAX-5, "Inspection"](#).
4. Transverse link ball joint axial end play. Refer to [FSU-11, "Removal and Installation"](#).
5. Shock absorber operation.
6. Each mounting part of axle and suspension for looseness and deformation.
7. Each of suspension member, shock absorber, upper link and transverse link for cracks, deformation and other damage.
8. Vehicle height (posture).

Alignment Process

IMPORTANT:

Use only the alignment specifications listed in this Service Manual.

- When displaying the alignment settings, many alignment machines use "indicators" **Do not use these indicators.**: (Green/red, plus or minus, Go/No Go).
- The alignment specifications programmed into your machine that operate these indicators may not be correct.

FRONT SUSPENSION ASSEMBLY

< ON-VEHICLE MAINTENANCE >

- This may result in an ERROR.
- Some newer alignment machines are equipped with an optional "Rolling Compensation" method to "compensate" the sensors (alignment targets or head units). Do not use this "Rolling Compensation" method.
- Use the "Jacking Compensation Method". After installing the alignment targets or head units, raise the vehicle and rotate the wheels 1/2 turn both ways.
- See Instructions in the alignment machine you're using for more information on this.

A
B

ADJUSTMENT

Camber, Caster and Kingpin Inclination Angles

CAUTION:
Camber, caster, kingpin inclination angles cannot be adjusted.

C
D

FSU

F
G
H
I
J
K
L
M
N
O
P

FRONT COIL SPRING AND STRUT

< ON-VEHICLE REPAIR >

ON-VEHICLE REPAIR

FRONT COIL SPRING AND STRUT

Removal and Installation

INFOID:000000001503443

REMOVAL

1. Remove tire using power tool.
2. Remove brake caliper and reposition aside using wire. Refer to [BR-24. "BRAKE CALIPER ASSEMBLY : Removal and Installation"](#).

CAUTION:

Avoid depressing brake pedal with brake caliper removed.

3. Remove wheel sensor electrical harness from strut.
4. Remove brake hose lock plate.
5. Remove mounting bolts and nuts securing steering knuckle to strut.
6. Remove mounting bolts on tower bar then remove strut from vehicle.

INSPECTION AFTER REMOVAL

Check the strut for any oil leakage or other damage and replace as necessary.

INSTALLATION

Installation is in the reverse order of removal.

- Refer to [FSU-13. "Exploded View"](#) for tightening torque.
- Be sure arrows on strut mount insulator and spring upper seat are positioned as shown. Also be sure notch in strut spacer is positioned as shown. Then install strut.
- Assemble upper mounting plate with its notch facing toward the outside.

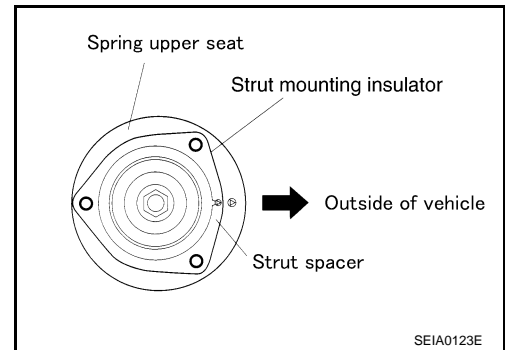

Disassembly and Assembly

INFOID:000000001503444

DISASSEMBLY

1. Install Tool to strut and fix it in a vise.

Tool number : ST35652000 (—)

CAUTION:

When installing Tool, wrap a shop cloth around strut to protect it from damage.

2. Slightly loosen piston rod lock nut.

WARNING:

Do not remove piston rod lock nut completely. If it is removed completely, the coil spring can jump out and may cause serious damage or injury.

3. Compress coil spring using a commercially available spring compressor.

WARNING:

Make sure that the pawls of the two spring compressors are firmly hooked on the spring. The spring compressors must be tightened alternately so as not to tilt the spring.

4. Making sure coil spring is free between upper and lower seats, then remove piston rod lock nut.
5. Remove small parts on strut.

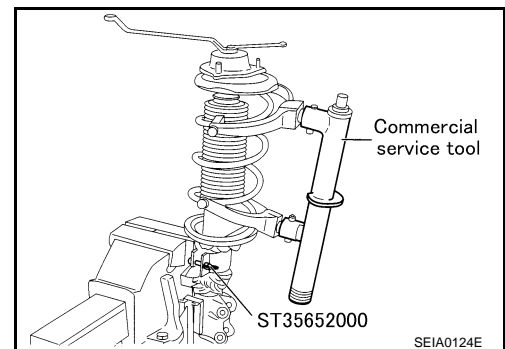

FRONT COIL SPRING AND STRUT

< ON-VEHICLE REPAIR >

- Remove strut spacer, strut mount insulator, strut mounting insulator bracket thrust bearing, spring upper seat, and upper rubber seat. Then remove coil spring.
6. Remove bound bumper from spring upper seat.
 7. Gradually release spring compressor (commercial service tool), and remove coil spring.

ASSEMBLY

1. Compress coil spring using a spring compressor (commercial service tool), and install it onto the strut.
CAUTION:
Face tube side of coil spring downward. Align lower end to spring seat as shown in the figure.
WARNING:
Be sure spring compressor is securely attached to coil spring. Compress coil spring.
2. Connect bound bumper to spring upper seat.
CAUTION:
 - Be sure to install bound bumper to spring upper seat securely.
 - When installing bound bumper, use soapy water. Do not use machine oil or other lubricants.
3. Install small parts to the strut.
 - Connect upper rubber seat, spring upper seats, thrust bearing, strut mount insulator, and strut spacer. Temporarily install piston rod lock nut.**CAUTION:**
Do not reuse piston rod lock nut.
4. Be sure arrows on strut mount insulator and spring upper seat are positioned as shown. Also be sure notch in the strut spacer is positioned as shown.
5. Be sure coil spring is properly set in spring rubber seat. Gradually release spring compressor.
CAUTION:
Be sure upper rubber seat is properly aligned to spring upper seat and coil spring.
6. Tighten piston rod lock nut to the specified torque.
7. Remove Tool from strut.

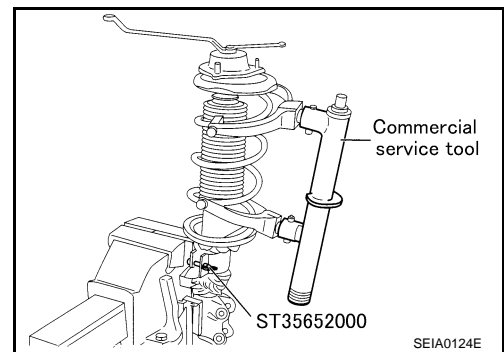
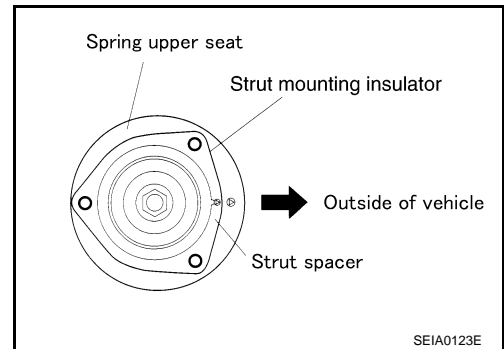
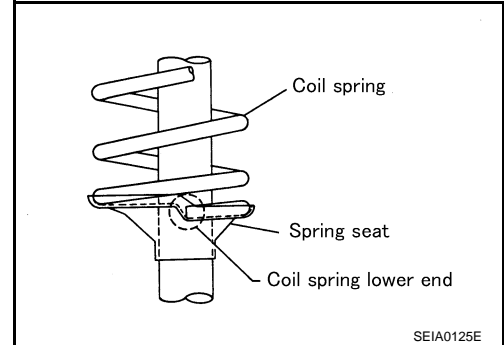

Inspection

INSPECTION AFTER DISASSEMBLY

Strut

- Check strut for deformation, cracks, and damage, and replace if necessary.
- Check piston rod for damage, uneven wear, and distortion, and replace if necessary.
- Check welded and sealed areas for oil leakage, and replace if necessary.

Insulator and Rubber Parts

Check strut mount insulator for cracks and rubber parts for wear. Replace them if necessary.

A
B
C
D
FSU
F
G
H
I
J
K
L
M
N
O
P

FRONT COIL SPRING AND STRUT

< ON-VEHICLE REPAIR >

Coil Spring

Check for cracks, wear, and damage, and replace if necessary.

TRANSVERSE LINK

< ON-VEHICLE REPAIR >

TRANSVERSE LINK

Removal and Installation

INFOID:000000001503446

REMOVAL

1. Remove tire using power tool.
2. Remove steering knuckle from transverse link. Refer to [FSU-13, "Exploded View"](#).
3. Remove mounting nuts and washers on lower portion of stabilizer connecting rod.
4. Slightly loosen transverse link mounting bolts.
5. Remove transverse link mounting bolts and nuts, and remove transverse link from suspension member.

INSPECTION AFTER REMOVAL

Visual Inspection

Check transverse link and bushing for deformation, cracks, and other damage. Replace the entire transverse link assembly if cracks, deformation or any other damage is found.

Ball Joint Inspection

CAUTION:

Before measurement, move the ball joint at least ten times by hand to check for smooth movement.

Swing Torque Inspection

- Hook spring scale at cotter pin mounting hole. Confirm spring scale measurement value is within specifications when ball stud begins moving.

Swing force:

0.50 - 3.4 N-m (0.06 - 0.34 kg-m, 5 - 30 in-lb)

Measurement on spring balance:

7.94 - 53.97 N (0.81 - 5.50 kg, 1.79 - 12.2 lb)

- If the value is outside the standard, replace transverse link.

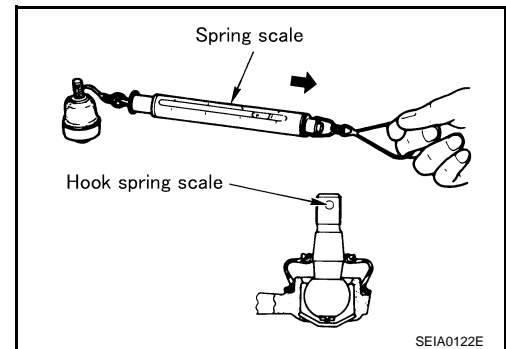

Rotating Torque Inspection

- Attach mounting nut to ball stud. Check that rotating torque is within specifications using Tool.

Tool number : ST3127S000 (J-25765-A)

Rotating torque:

0.50 - 3.4 N-m (0.06 - 0.34 kg-m, 5 - 30 in-lb)

- If the value is outside the standard, replace transverse link.

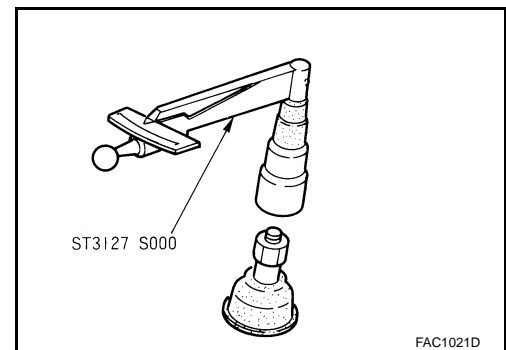

Axial Endplay Inspection

- Move tip of ball joint in axial direction to check for looseness.

Axial endplay : 0.1 mm (0.004 in) or less

- If any looseness is noted, replace transverse link.

INSTALLATION

Installation is in the reverse order of removal.

- Refer to [FSU-13, "Exploded View"](#) for tightening torque.
- Tighten transverse link mounting bolts with vehicle unladen and all four tyre on flat, level ground.
- After installation, check wheel alignment. Refer to [FSU-6, "Inspection and Adjustment"](#).

A
B
C
D
FSU
F
G
H
I
J
K
L
M
N
O
P

FRONT STABILIZER

< ON-VEHICLE REPAIR >

FRONT STABILIZER

Removal and Installation

INFOID:000000001503447

REMOVAL

1. Remove tire using power tool.
2. Remove mounting nuts on upper portion of stabilizer connecting rod.

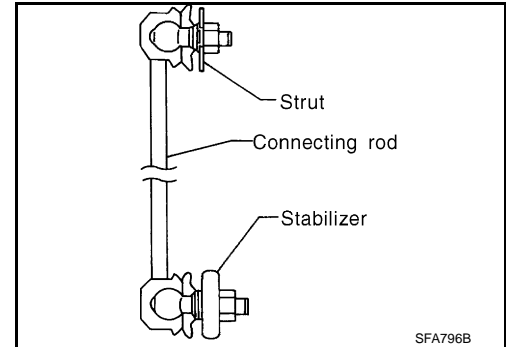

3. Remove stabilizer clamp mounting bolts.
4. Remove stabilizer from the vehicle.

INSPECTION AFTER REMOVAL

Check stabilizer, connecting rod, bushing and clamp for deformation, cracks and damage, and replace if necessary.

INSTALLATION

Installation is in the reverse order of removal. Refer to [FSU-13, "Exploded View"](#) in the reverse order of removal.

- When installing stabilizer, make sure that the clamps are facing in the direction shown.
- Make sure the cut surface of the bushing faces the rear.

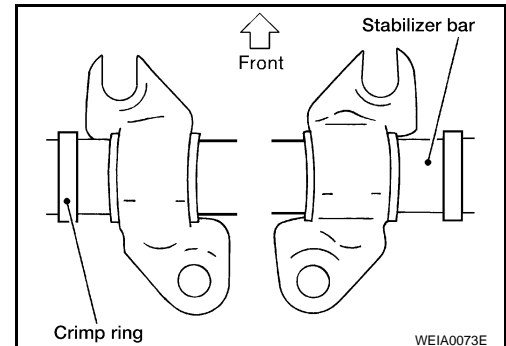

- Stabilizer uses pillow ball type connecting rod. Position ball joint with case on pillow ball head parallel to stabilizer.

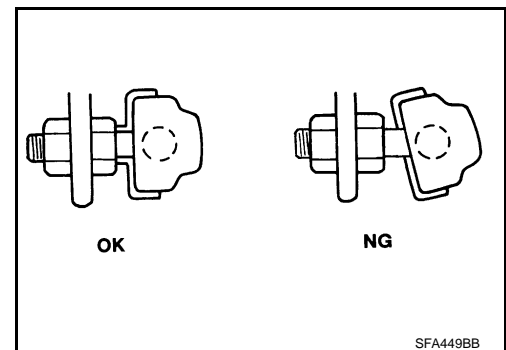

FRONT SUSPENSION ASSEMBLY

< REMOVAL AND INSTALLATION >

REMOVAL AND INSTALLATION

FRONT SUSPENSION ASSEMBLY

Exploded View

INFOID:000000001503448

SEC. 400 • 401 • 406

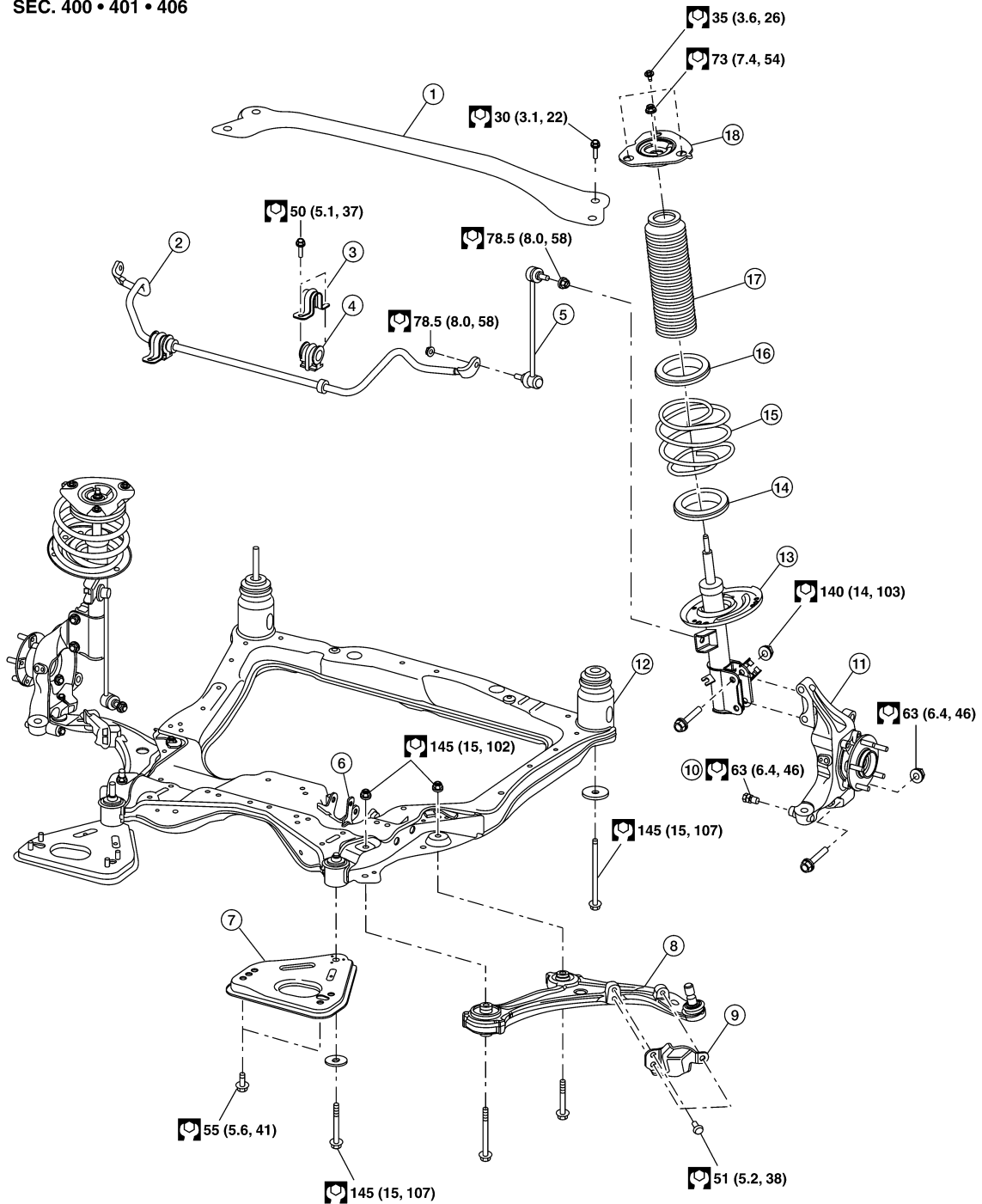

A
B
C
D
E
F
G
H
I
J
K
L
M
N
O
P

FSU

FRONT SUSPENSION ASSEMBLY

< REMOVAL AND INSTALLATION >

- | | | |
|-----------------------|-----------------------|-----------------------------|
| 1. Strut tower bar | 2. Stabilizer bar | 3. Stabilizer clamp |
| 4. Stabilizer bushing | 5. Connecting rod | 6. Engine mount bracket |
| 7. Member pin stay | 8. Transverse link | 9. Steering stop plate |
| 10. Steering stop | 11. Steering knuckle | 12. Front suspension member |
| 13. Strut | 14. Lower rubber seat | 15. Coil spring |
| 16. Upper rubber seat | 17. Dust cover | 18. Strut mount insulator |

Removal and Installation

INFOID:000000001503449

REMOVAL

Engine, transmission and suspension member must be removed as an assembly. Refer to [EM-70, "Removal and Installation"](#).

Once removed as an assembly, lift engine and transmission off of suspension member.

INSTALLATION

- Refer to [FSU-13, "Exploded View"](#) for tightening torque in the reverse order of removal.
- After installation, perform final tightening of each part under unladen conditions with tyre on ground. Check wheel alignment. Refer to [FSU-6, "Inspection and Adjustment"](#).

SERVICE DATA AND SPECIFICATIONS (SDS)

< SERVICE DATA AND SPECIFICATIONS (SDS)

SERVICE DATA AND SPECIFICATIONS (SDS)

SERVICE DATA AND SPECIFICATIONS (SDS)

Wheel Alignment

INFOID:000000001503450

Camber ★ Decimal degree	LH	Minimum	- 1.15°
		Nominal	- 0.40°
		Maximum	0.35°
	RH	Minimum	- 1.40°
		Nominal	- 0.65°
		Maximum	0.10°
	Left and right difference		
Caster ★ Decimal degree	Minimum	4.25°	
	Nominal	5.00°	
	Maximum	5.75°	
	Left and right difference	0.25°	
Kingpin offset ★ Decimal degree	Minimum	11.80°	
	Nominal	12.55°	
	Maximum	13.30°	

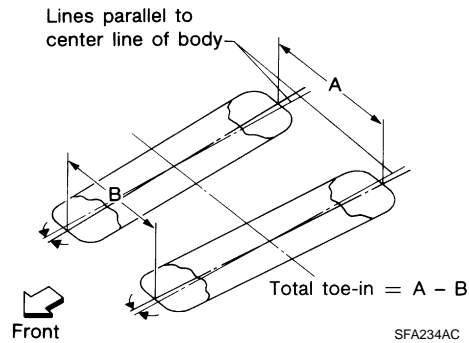

Total toe-in ★	Distance (A - B)	Minimum	0 mm (0 in)
		Nominal	1 mm (0.04 in)
		Maximum	2 mm (0.08 in)
Wheel turning angel ★	Refer to ST-17, "Steering Angle" .		

★: Fuel, radiator coolant and engine oil full. Spare tire, jack, hand tools and mats in designated positions.

Ball Joint

INFOID:000000001503451

Swing torque	0.50 - 3.4 N·m (0.06 - 0.34 kg·m, 5 - 30 in·lb)
Measurement on spring balance (cotter pinhole position)	7.94 - 53.97 N (0.81 - 5.50 kg, 1.79 - 12.2 lb)
Turning torque	0.50 - 3.4 N·m (0.06 - 0.34 kg·m, 5 - 30 in·lb)
Axial endplay	0.1 mm (0.004 in) or less

SERVICE DATA AND SPECIFICATIONS (SDS)

< SERVICE DATA AND SPECIFICATIONS (SDS)

Wheel Height

INFOID:000000001503452

Unit: mm (in)

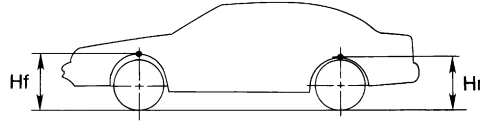

SFA818A

Destination	USA	Canada
Tire size	215/60R16	215/60R16
Front (Hf)*	727 (28.62)	727 (28.62)
Rear (Hr)*	718 (28.27)	719 (28.31)

*: Fuel, engine coolant and engine oil full. Spare tire, jack, hand tools and mats in designated positions.