

SECTION **DEF**  
**DEFOGGER**

A  
B  
C

CONTENTS

<b>BASIC INSPECTION</b> .....	3	Diagnosis Procedure .....	14	F
<b>DIAGNOSIS AND REPAIR WORKFLOW</b> .....	3	Component Inspection .....	15	
Work Flow .....	3	<b>DRIVER SIDE DOOR MIRROR DEFOGGER</b> ...	16	G
<b>FUNCTION DIAGNOSIS</b> .....	6	Description .....	16	
<b>REAR WINDOW DEFOGGER SYSTEM</b> .....	6	Component Function Check .....	16	
System Diagram .....	6	Diagnosis Procedure .....	16	H
System Description .....	6	Component Inspection .....	17	
Component Parts Location .....	7	<b>PASSENGER SIDE DOOR MIRROR DEFOG-</b>		
Component Description .....	7	<b>GER</b> .....	18	I
<b>DIAGNOSIS SYSTEM (BCM)</b> .....	9	Description .....	18	
<b>COMMON ITEM</b> .....	9	Component Function Check .....	18	
COMMON ITEM : CONSULT-III Function (BCM -		Diagnosis Procedure .....	18	J
COMMON ITEM) .....	9	Component Inspection .....	19	
<b>REAR WINDOW DEFOGGER</b> .....	9	<b>ECU DIAGNOSIS</b> .....	20	K
REAR WINDOW DEFOGGER : CONSULT-III		<b>BCM (BODY CONTROL MODULE)</b> .....	20	
Function (BCM - REAR DEFOGGER) .....	9	Reference Value .....	20	
<b>CAN COMMUNICATION</b> .....	10	Wiring Diagram .....	21	DEF
System Description .....	10	<b>SYMPTOM DIAGNOSIS</b> .....	27	
<b>COMPONENT DIAGNOSIS</b> .....	11	<b>REAR WINDOW DEFOGGER AND DOOR</b>		
<b>REAR WINDOW DEFOGGER SWITCH</b> .....	11	<b>MIRROR DEFOGGER DO NOT OPERATE.</b> ....	27	M
Description .....	11	Diagnosis Procedure .....	27	
Component Function Check .....	11	<b>REAR WINDOW DEFOGGER DOES NOT</b>		
Diagnosis Procedure .....	11	<b>OPERATE BUT BOTH OF DOOR MIRROR</b>		N
<b>REAR WINDOW DEFOGGER RELAY</b> .....	12	<b>DEFOGGER OPERATE.</b> .....	28	
Description .....	12	Diagnosis Procedure .....	28	O
Component Function Check .....	12	<b>BOTH DOORS MIRROR DEFOGGER DON'T</b>		
Diagnosis Procedure .....	12	<b>OPERATE BUT REAR WINDOW DEFOG-</b>		
Component Inspection .....	13	<b>GER OPERATES</b> .....	29	P
<b>REAR WINDOW DEFOGGER POWER SUP-</b>		Diagnosis Procedure .....	29	
<b>PLY AND GROUND CIRCUIT</b> .....	14	<b>DRIVER SIDE DOOR MIRROR DEFOGGER</b>		
Description .....	14	<b>DOES NOT OPERATE.</b> .....	30	
Component Function Check .....	14	Diagnosis Procedure .....	30	

<b>PASSENGER SIDE DOOR MIRROR DEFOGGER DOES NOT OPERATE.</b> .....	<b>31</b>	<b>PRECAUTIONS</b> .....	<b>33</b>
Diagnosis Procedure .....	31	Supplemental Restraint System (SRS) "AIR BAG" and "SEAT BELT PRE-TENSIONER" .....	33
<b>REAR WINDOW DEFOGGER SWITCH DOES NOT LIGHT, BUT REAR WINDOW DEFOGGER OPERATES</b> .....	<b>32</b>	<b>ON-VEHICLE REPAIR</b> .....	<b>34</b>
Diagnosis Procedure .....	32	<b>FILAMENT</b> .....	<b>34</b>
<b>PRECAUTION</b> .....	<b>33</b>	Inspection and Repair .....	34
		<b>CONDENSER</b> .....	<b>36</b>
		Exploded View .....	36
		Removal and Installation .....	36

# DIAGNOSIS AND REPAIR WORKFLOW

< BASIC INSPECTION >

## BASIC INSPECTION

### DIAGNOSIS AND REPAIR WORKFLOW

Work Flow

INFOID:000000001502272

OVERALL SEQUENCE

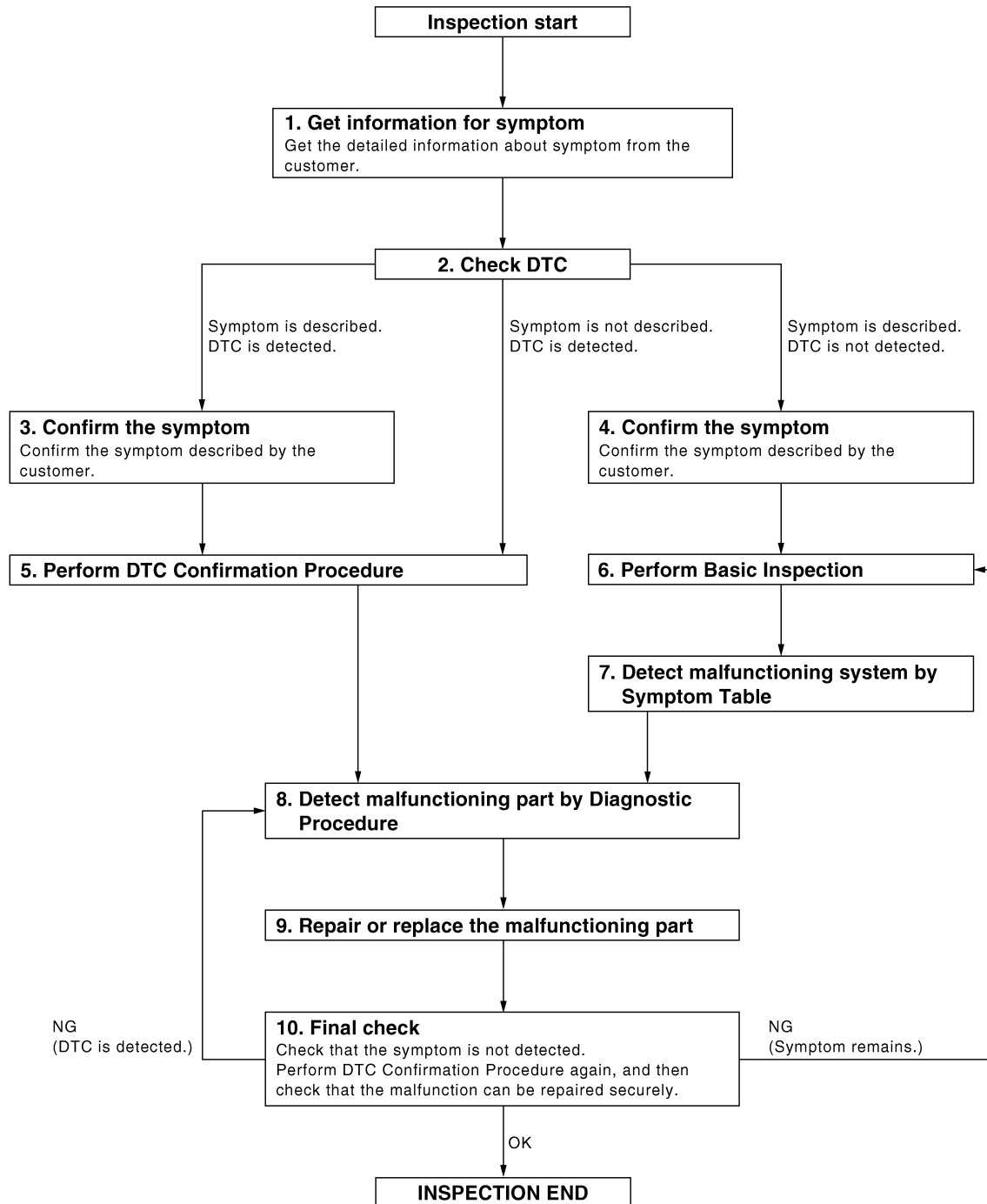

DETAILED FLOW

# DIAGNOSIS AND REPAIR WORKFLOW

< BASIC INSPECTION >

---

## 1. GET INFORMATION FOR SYMPTOM

---

Get the detailed information from the customer about the symptom (the condition and the environment when the incident/malfunction occurred).

>> GO TO 2

## 2. CHECK DTC

---

1. Check DTC.
2. Perform the following procedure if DTC is displayed.
  - Record DTC and freeze frame data (Print them out with CONSULT-III.)
  - Erase DTC.
  - Study the relationship between the cause detected by DTC and the symptom described by the customer.
3. Check related service bulletins for information.

Is any symptom described and any DTC detected?

- Symptom is described, DTC is displayed>>GO TO 3
- Symptom is described, DTC is not displayed>>GO TO 4
- Symptom is not described, DTC is displayed>>GO TO 5

## 3. CONFIRM THE SYMPTOM

---

Confirm the symptom described by the customer.  
Connect CONSULT-III to the vehicle in "DATA MONITOR" mode and check real time diagnosis results.  
Verify relation between the symptom and the condition when the symptom is detected.

>> GO TO 5

## 4. CONFIRM THE SYMPTOM

---

Confirm the symptom described by the customer.  
Connect CONSULT-III to the vehicle in "DATA MONITOR" mode and check real time diagnosis results.  
Verify relation between the symptom and the condition when the symptom is detected.

>> GO TO 6

## 5. PERFORM DTC CONFIRMATION PROCEDURE

---

Perform DTC Confirmation Procedure for the displayed DTC, and then check that DTC is detected again.  
At this time, always connect CONSULT-III to the vehicle, and check diagnostic results in real time.  
If two or more DTCs are detected, refer to [BCS-72. "DTC Inspection Priority Chart"](#) and determine trouble diagnosis order.

### NOTE:

- Freeze frame data is useful if the DTC is not detected.
- Perform Component Function Check if DTC Confirmation Procedure is not included in Service Manual. This simplified check procedure is an effective alternative though DTC cannot be detected during this check.  
If the result of Component Function Check is NG, it is the same as the detection of DTC by DTC Confirmation Procedure.

Is DTC detected?

- YES >> GO TO 8
- NO >> Refer to [GI-42. "Intermittent Incident"](#).

## 6. PERFORM BASIC INSPECTION

---

Perform [DEF-3. "Work Flow"](#).

Inspection End>>GO TO 7

## 7. DETECT MALFUNCTIONING SYSTEM BY SYMPTOM TABLE

---

Detect malfunctioning system according to [DEF-6. "System Description"](#) based on the confirmed symptom in step 4, and determine the trouble diagnosis order based on possible causes and symptom.

>> GO TO 8

# DIAGNOSIS AND REPAIR WORKFLOW

< BASIC INSPECTION >

---

## 8. DETECT MALFUNCTIONING PART BY DIAGNOSTIC PROCEDURE

---

Inspect according to Diagnostic Procedure of the system.

**NOTE:**

The Diagnostic Procedure described based on open circuit inspection. A short circuit inspection is also required for the circuit check in the Diagnostic Procedure.

Is malfunctioning part detected?

YES >> GO TO 9

NO >> Check voltage of related BCM terminals using CONSULT-III.

---

## 9. REPAIR OR REPLACE THE MALFUNCTIONING PART

---

1. Repair or replace the malfunctioning part.
2. Reconnect parts or connectors disconnected during Diagnostic Procedure again after repair and replacement.
3. Check DTC. If DTC is displayed, erase it.

>> GO TO 10

---

## 10. FINAL CHECK

---

When DTC was detected in step 2, perform DTC Confirmation Procedure or Component Function Check again, and then check that the malfunction have been repaired securely.

When symptom was described from the customer, refer to confirmed symptom in step 3 or 4, and check that the symptom is not detected.

Does the symptom reappear?

YES (DTC is detected)>>GO TO 8

YES (Symptom remains)>>GO TO 6

NO >> **INSPECTION END**

A  
B  
C  
D  
E  
F  
G  
H  
I  
J  
K  
M  
N  
O  
P

DEF

# REAR WINDOW DEFOGGER SYSTEM

< FUNCTION DIAGNOSIS >

## FUNCTION DIAGNOSIS

### REAR WINDOW DEFOGGER SYSTEM

#### System Diagram

INFOID:000000001502273

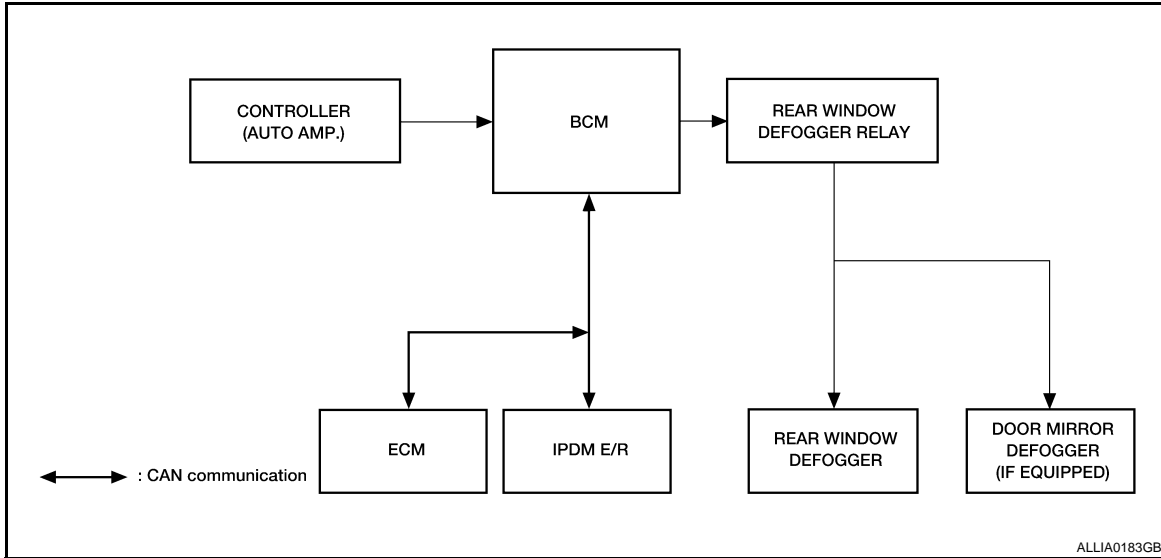

#### System Description

INFOID:000000001502274

#### Operation Description

- Turn rear window defogger switch ON when the ignition switch is turned ON. Then controller (auto amp.) (rear window defogger switch) transmits rear window defogger switch signal to BCM.
- BCM turns rear window defogger relay ON when rear window defogger switch signal is received.
- Rear window defogger and door mirror defogger (with door mirror defogger) are supplied with power and operate when rear window defogger relay turns ON.
- BCM transmits rear window defogger control signal to IPDM E/R via CAN communication when rear window defogger operates.
- Rear window defogger ON is displayed when controller (auto amp.) receives signals.

#### Timer function

- BCM turns rear window defogger relay ON for approximately 15 minutes when rear window defogger switch is turned ON while ignition switch is ON. It makes rear window defogger and door mirror defogger (with door mirror defogger) operate.
- Timer is canceled after pressing rear window defogger switch again during timer operation. Then BCM turns rear window defogger relay OFF. The same reaction also occurs during timer operation, if the ignition switch is turned OFF.

#### INPUT/OUTPUT SIGNAL CHART

Switch	Input signal to BCM	BCM function	Acuator
Rear window defogger switch	Defogger switch signal	Rear window defogger & Door mirror defogger* control	Rear window defogger
Push button ignition switch	Ignition signal		Door mirror defogger*

\*: With door mirror defogger

# REAR WINDOW DEFOGGER SYSTEM

< FUNCTION DIAGNOSIS >

## Component Parts Location

INFOID:000000001502275

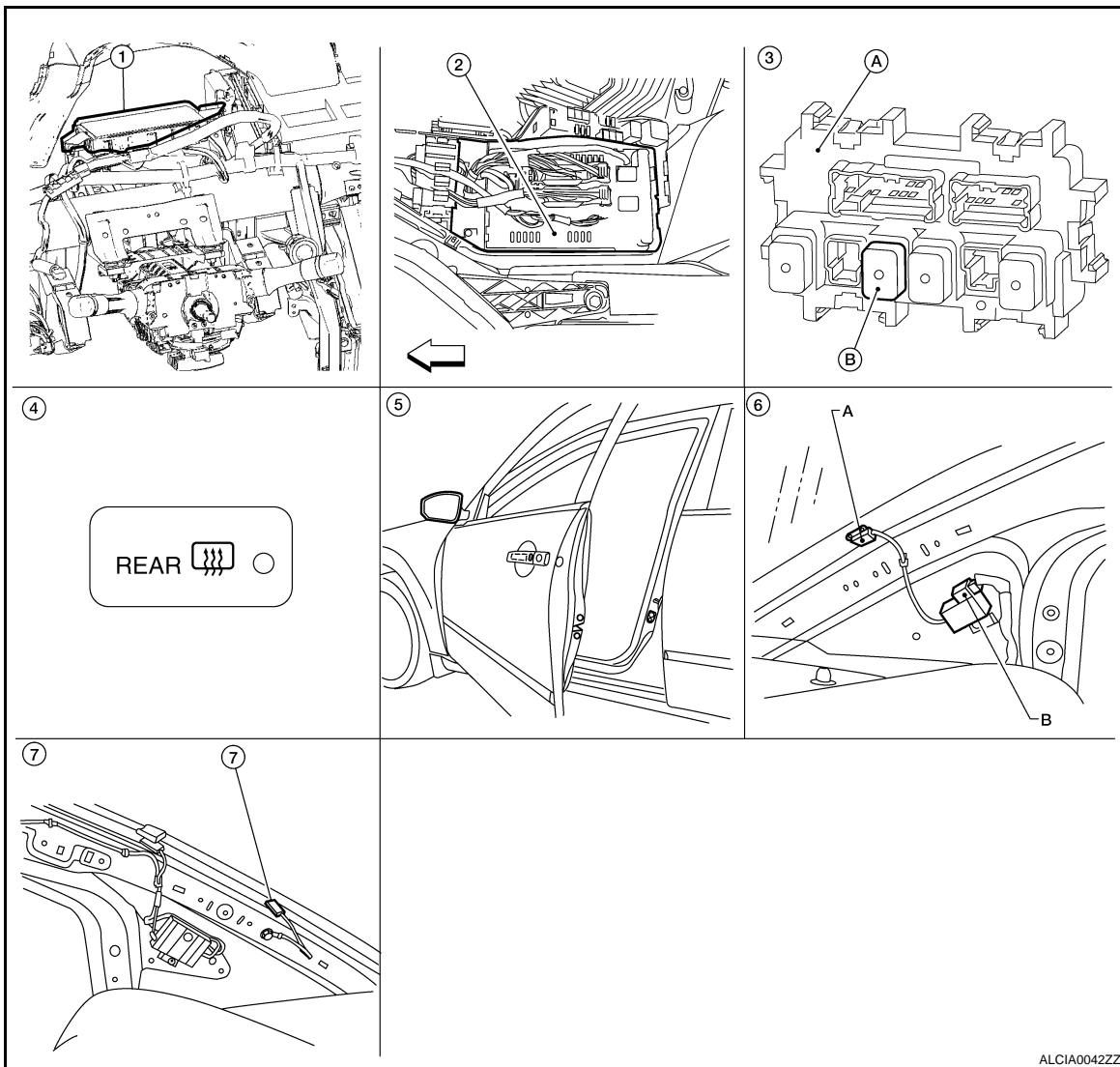

ALCIA004ZZZ

- |   |  |  |
|---|--|--|
| <p>1. BCM M16, M17, M18, M19 (view with instrument panel removed)</p> <p>4. Controller (auto amp.) (rear window defogger switch) M37</p> <p>7. Rear window defogger (-) M54 (view with rear pillar finisher LH removed)</p> | <p>2. IPDM E/R E17</p> <p>5. Door mirror (door mirror defogger) LH D4, RH D107</p> | <p>3. A. Fuse block (J/B)<br/>B. Rear window defogger relay</p> <p>6. A. Rear window defogger (+) B53<br/>B. Condenser B52 (view with rear pillar finisher RH removed)</p> |
|---|--|--|

## Component Description

INFOID:000000001502276

BCM	<ul style="list-style-type: none"> <li>Operates the rear window defogger with the operation of rear window defogger switch.</li> <li>Performs the timer control of rear window defogger.</li> </ul>
Rear window defogger relay	<ul style="list-style-type: none"> <li>Operates the rear window defogger and the door mirror defogger with the control signal from BCM.</li> </ul>
Controller (auto amp.) (rear window defogger switch)	<ul style="list-style-type: none"> <li>The rear window defogger switch is turned ON.</li> <li>Turns the indicator lamp ON when detecting the operation of rear window defogger.</li> </ul>

## REAR WINDOW DEFOGGER SYSTEM

### < FUNCTION DIAGNOSIS >

Rear window defogger	<ul style="list-style-type: none"><li>• Heats the heating wire with the power supply from the rear window defogger relay to prevent the rear window from fogging up.</li></ul>
Door mirror defogger*	<ul style="list-style-type: none"><li>• Heats the heating wire with the power supply from the rear window defogger relay to prevent the door mirror from fogging up.</li></ul>

\*: With door mirror defogger



# DIAGNOSIS SYSTEM (BCM)

< FUNCTION DIAGNOSIS >

## DIAGNOSIS SYSTEM (BCM)

### COMMON ITEM

#### COMMON ITEM : CONSULT-III Function (BCM - COMMON ITEM)

INFOID:000000001502277

#### APPLICATION ITEM

CONSULT-III performs the following functions via CAN communication with BCM.

Diagnosis mode	Function Description
WORK SUPPORT	Changes the setting for each system function.
SELF-DIAG RESULTS	Displays the diagnosis results judged by BCM. Refer to <a href="#">BCS-74, "DTC Index"</a> .
CAN DIAG SUPPORT MNTR	Monitors the reception status of CAN communication viewed from BCM.
DATA MONITOR	The BCM input/output signals are displayed.
ACTIVE TEST	The signals used to activate each device are forcibly supplied from BCM.
ECU IDENTIFICATION	The BCM part number is displayed.
CONFIGURATION	This function is not used even though it is displayed.

#### SYSTEM APPLICATION

BCM can perform the following functions for each system.

**NOTE:**

It can perform the diagnosis modes except the following for all subsystem selection items.

System	Sub system selection item	Diagnosis mode		
		WORK SUPPORT	DATA MONITOR	ACTIVE TEST
Rear window defogger	REAR DEFOGGER		×	×
BCM	BCM	×		

### REAR WINDOW DEFOGGER

#### REAR WINDOW DEFOGGER : CONSULT-III Function (BCM - REAR DEFOGGER)

INFOID:000000001502278

#### Data monitor

Monitor Item	Description
REAR DEF SW	Indicates [ON/OFF] condition of rear defogger switch.
PUSH SW	Indicates [ON/OFF] condition of push switch.

#### ACTIVE TEST

Test Item	Description
REAR DEFOGGER	This test is able to check rear window defogger operation. Rear window defogger operates when "ON" on CONSULT-III screen is touched.

# CAN COMMUNICATION

< FUNCTION DIAGNOSIS >

---

## CAN COMMUNICATION

### System Description

INFOID:000000001502279

Refer to [LAN-7. "System Description"](#).

# REAR WINDOW DEFOGGER SWITCH

< COMPONENT DIAGNOSIS >

## COMPONENT DIAGNOSIS

### REAR WINDOW DEFOGGER SWITCH

#### Description

INFOID:000000001502280

- The rear window defogger is operated by turning the rear window defogger switch ON.
- Turns the indicator lamp in the rear window defogger switch ON when operating the rear window defogger.

#### Component Function Check

INFOID:000000001502281

#### 1. CHECK REAR WINDOW DEFOGGER SWITCH FUNCTION

Check that the indicator lamp of rear window defogger illuminates with rear window defogger switch ON.

Is the inspection result normal?

- YES >> Rear window defogger switch function is OK.  
 NO >> Refer to [DEF-11, "Diagnosis Procedure"](#).

#### Diagnosis Procedure

INFOID:000000001502282

#### 1. CHECK CONTROLLER (AUTO AMP.) (REAR WINDOW DEFOGGER SWITCH)

Does controller (auto amp.) operate normally?

Is the inspection result normal?

- YES >> Inspection End.  
 NO >> GO TO 2

#### 2. CHECK REAR WINDOW DEFOGGER SWITCH INDICATOR CIRCUIT

1. Turn ignition switch ON.
2. Check voltage between controller (auto amp.) connector and ground.

Terminals		(-)	Condition of rear window defogger switch	Voltage (V) (Approx.)
(+)	Terminal			
Controller (auto amp.) connector				
M37	22	Ground	ON	Battery voltage
			OFF	0

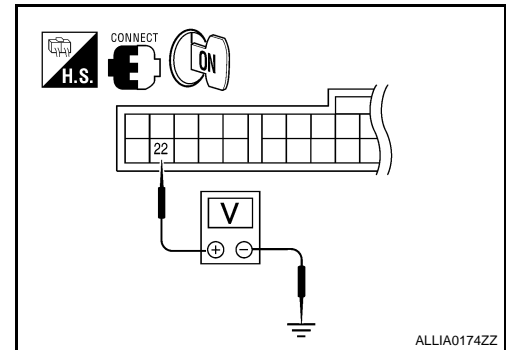

Is the inspection result normal?

- YES >> Repair or replace harness.  
 NO >> Replace controller (auto amp.). Refer to [VTL-8, "Removal and Installation"](#).

A  
B  
C  
D  
E  
F  
G  
H  
I  
J  
K  
DEF  
M  
N  
O  
P

# REAR WINDOW DEFOGGER RELAY

< COMPONENT DIAGNOSIS >

## REAR WINDOW DEFOGGER RELAY

### Description

INFOID:000000001502283

Power is supplied to the rear window defogger with BCM control.

### Component Function Check

INFOID:000000001502284

#### 1. CHECK REAR WINDOW DEFOGGER RELAY POWER SUPPLY CIRCUIT

Check that an operation noise of rear window defogger relay [located in fuse block (J/B)] can be heard when turning the rear window defogger switch ON.

Is the inspection result normal?

- YES >> Rear window defogger relay power supply circuit is OK.
- NO >> Refer to [DEF-12. "Diagnosis Procedure"](#).

### Diagnosis Procedure

INFOID:000000001502285

#### 1. CHECK REAR WINDOW DEFOGGER RELAY GROUND CIRCUIT

1. Turn ignition switch ON.
2. Check voltage between BCM connector and ground.

Terminals		(-)	Condition of rear window defogger switch	Voltage (V) (Approx.)
(+)				
BCM connector	Terminal			
M18	59	Ground	ON	0
			OFF	Battery voltage

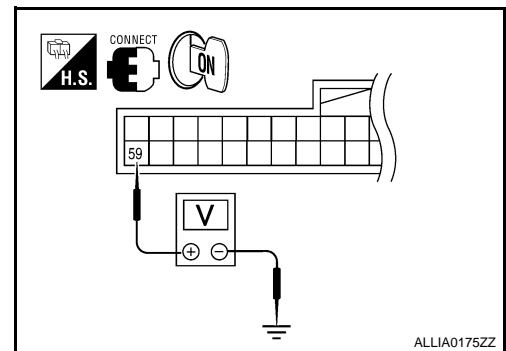

ALLIA0175ZZ

Is the inspection result normal?

- YES >> Rear window defogger power supply circuit is OK.
- NO >> GO TO 2

#### 2. CHECK HARNESS CONTINUITY

1. Turn ignition switch OFF.
2. Disconnect BCM and fuse block (J/B).
3. Check continuity between BCM connector (A) and fuse block (J/B) connector (B).

BCM connector	Terminal	Fuse block (J/B) connector	Terminal	Continuity
M18 (A)	59	M4 (B)	4Q	Yes

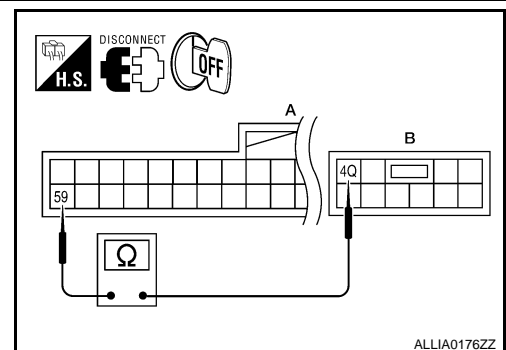

ALLIA0176ZZ

Is the inspection result normal?

- YES >> GO TO 3
- NO >> Repair or replace harness.

#### 3. CHECK REAR WINDOW DEFOGGER RELAY

Check rear window defogger relay.  
Refer to [DEF-13. "Component Inspection"](#).

Is the inspection result normal?

- YES >> GO TO 4
- NO >> Replace rear window defogger relay.

#### 4. CHECK INTERMITTENT INCIDENT

Check intermittent incident.  
Refer to [GI-42. "Intermittent Incident"](#)

Is the inspection result normal?

- YES >> Check the following.

# REAR WINDOW DEFOGGER RELAY

## < COMPONENT DIAGNOSIS >

- Battery power supply circuit.
- Fuse block (J/B).

NO >> Repair or replace the malfunctioning parts.

## Component Inspection

INFOID:000000001502286

### 1. CHECK REAR WINDOW DEFOGGER RELAY

Check rear window defogger relay.

Terminal		Condition	Continuity
Rear window defogger relay			
3	5	12V direct current supply between terminals 1 and 2.	Yes
		No current supply	No

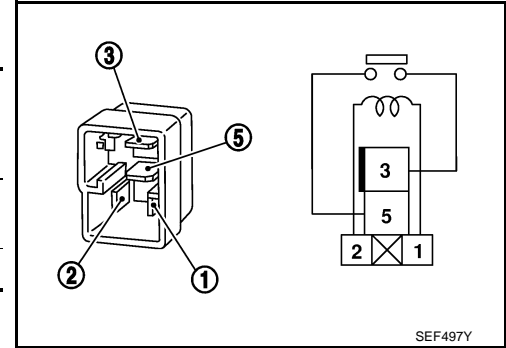

SEF497Y

Is the inspection result normal?

YES >> Inspection End.

NO >> Replace rear window defogger relay.

A  
B  
C  
D  
E  
F  
G  
H  
I  
J  
K  
DEF  
M  
N  
O  
P

# REAR WINDOW DEFOGGER POWER SUPPLY AND GROUND CIRCUIT

< COMPONENT DIAGNOSIS >

## REAR WINDOW DEFOGGER POWER SUPPLY AND GROUND CIRCUIT

### Description

INFOID:000000001502287

Heats the heating wire with the power supply from the rear window defogger relay to prevent the rear window from fogging up.

### Component Function Check

INFOID:000000001502288

### 1. CHECK REAR WINDOW DEFOGGER

Check that the heating wire of rear window defogger is heated when turning the rear window defogger switch ON.

Is the inspection result normal?

- YES >> Rear window defogger is OK.
- NO >> Refer to [DEF-14, "Diagnosis Procedure"](#).

### Diagnosis Procedure

INFOID:000000001502289

#### 1. CHECK POWER SUPPLY CIRCUIT

1. Turn ignition switch ON.
2. Check voltage between rear window defogger connector and ground.

Terminals		(-)	Condition of rear window defogger switch	Voltage (V) (Approx.)
(+)				
Rear window defogger connector	Terminal			
B53	1	Ground	ON	Battery voltage
			OFF	0

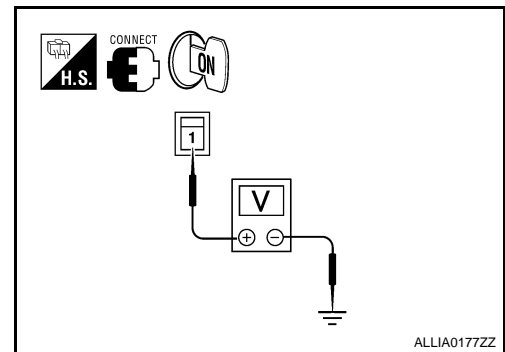

Is the inspection result normal?

- YES >> GO TO 2
- NO >> GO TO 3

#### 2. CHECK GROUND CIRCUIT

1. Turn ignition switch OFF.
2. Disconnect rear window defogger.
3. Check continuity between rear window defogger connector and ground.

Rear window defogger connector	Terminal	Ground	Continuity
B54	2		

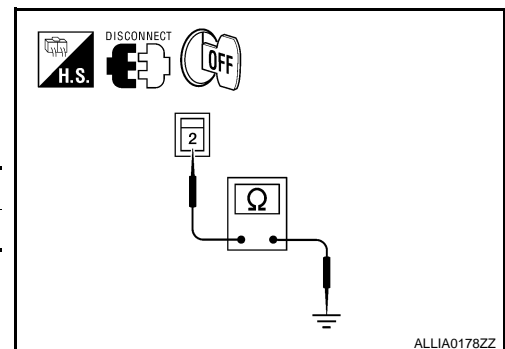

Is the inspection result normal?

- YES >> GO TO 5
- NO >> Repair or replace harness.

#### 3. CHECK HARNESS CONTINUITY 1

# REAR WINDOW DEFOGGER POWER SUPPLY AND GROUND CIRCUIT

## < COMPONENT DIAGNOSIS >

1. Turn ignition switch OFF.
2. Disconnect condenser and rear window defogger.
3. Check continuity between condenser connector (A) and rear window defogger connector (B).

Condenser connector	Terminal	Rear window defogger connector	Terminal	Continuity
B52 (A)	1	B53 (B)	1	Yes

Is the inspection result normal?

- YES >> GO TO 4  
 NO >> Replace condenser. Refer to [DEF-36, "Removal and Installation"](#).

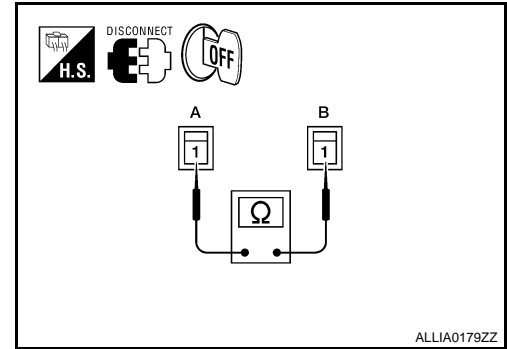

## 4. CHECK HARNESS CONTINUITY 2

1. Disconnect fuse block (J/B).
2. Check continuity between fuse block (J/B) connector (A) and condenser connector (B).

Fuse block (J/B) connector	Terminal	Condenser connector	Terminal	Continuity
B4 (A)	10T	B52 (B)	1	Yes
	11T			

Is the inspection result normal?

- YES >> GO TO 6  
 NO >> Replace or repair harness.

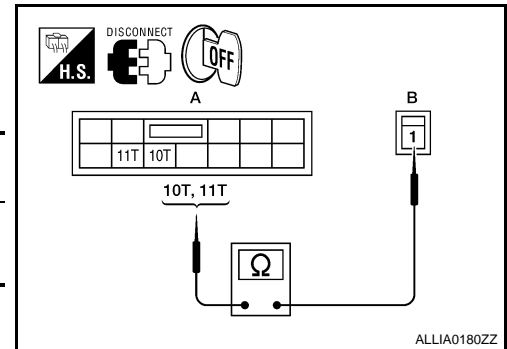

## 5. CHECK FILAMENT

Check filament.

Refer to [DEF-15, "Component Inspection"](#).

Is the inspection result normal?

- YES >> Refer to [GI-42, "Intermittent Incident"](#).  
 NO >> Repair filament. Refer to [DEF-34, "Inspection and Repair"](#).

## 6. CHECK INTERMITTENT INCIDENT

Check intermittent incident.

Refer to [GI-42, "Intermittent Incident"](#).

Is the inspection result normal?

- YES >> Check the following.
- Battery power supply circuit.
  - Fuse block (J/B).
- NO >> Repair or replace the malfunctioning parts.

## Component Inspection

INFOID:000000001502290

## 1. CHECK FILAMENT

Check the filament for damage or open circuits.

Refer to [DEF-34, "Inspection and Repair"](#).

Is the inspection result normal?

- YES >> Inspection End.  
 NO >> Repair filament. Refer to [DEF-34, "Inspection and Repair"](#).

# DRIVER SIDE DOOR MIRROR DEFOGGER

< COMPONENT DIAGNOSIS >

## DRIVER SIDE DOOR MIRROR DEFOGGER

### Description

INFOID:000000001502291

Heats the heating wire with the power supply from the rear window defogger relay to prevent the door mirror from fogging up.

### Component Function Check

INFOID:000000001502292

#### 1. CHECK DOOR MIRROR DEFOGGER LH

Check that heating wire of door mirror defogger LH is heated when turning the rear window defogger switch ON.

Is the inspection result normal?

- YES >> Door mirror defogger is OK.
- NO >> Refer to [DEF-16. "Diagnosis Procedure"](#).

### Diagnosis Procedure

INFOID:000000001502293

#### 1. CHECK POWER SUPPLY CIRCUIT

1. Turn ignition switch OFF.
2. Disconnect door mirror LH.
3. Turn ignition switch ON.
4. Check voltage between door mirror LH connector and ground.

Terminals		(-)	Condition of rear window defogger switch	Voltage (V) (Approx.)
(+)	Terminal			
Door mirror LH connector			ON	Battery voltage
D4	1	Ground	OFF	0

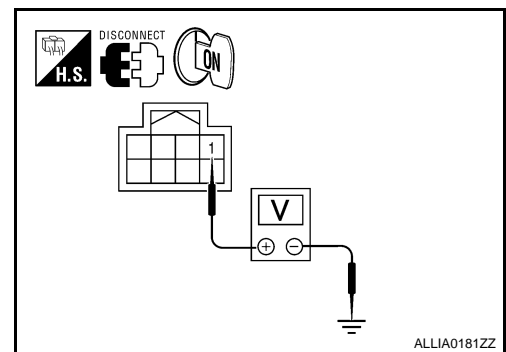

Is the inspection result normal?

- YES >> GO TO 2
- NO >> Repair or replace harness.

#### 2. CHECK GROUND CIRCUIT

1. Turn ignition switch OFF.
2. Check continuity between door mirror LH connector and ground.

Door mirror LH connector	Terminal	Ground	Continuity
D4	2		Yes

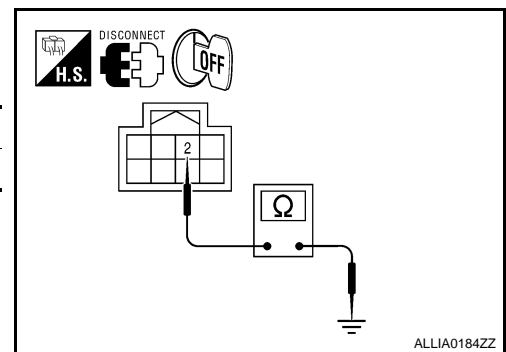

Is the inspection result normal?

- YES >> GO TO 3
- NO >> Repair or replace harness.

#### 3. CHECK DOOR MIRROR DEFOGGER LH

Check door mirror defogger LH.  
Refer to [DEF-17. "Component Inspection"](#).

Is the inspection result normal?

- YES >> GO TO 4
- NO >> Replace door mirror. Refer to [MIR-16. "Removal and Installation"](#).

#### 4. CHECK INTERMITTENT INCIDENT

Check intermittent incident.



# DRIVER SIDE DOOR MIRROR DEFOGGER

## < COMPONENT DIAGNOSIS >

Refer to [GI-42, "Intermittent Incident"](#).

Is the inspection result normal?

- YES >> Check the following.
- Battery power supply circuit.
  - Fuse block (J/B).
- NO >> Repair or replace the malfunctioning parts.

## Component Inspection

INFOID:000000001502294

### 1. CHECK DOOR MIRROR DEFOGGER LH

1. Turn ignition switch OFF.
2. Disconnect door mirror LH.
3. Check continuity between door mirror terminals.

Terminal		Continuity
1	2	Yes

Is the inspection result normal?

- YES >> Inspection End.
- NO >> Replace door mirror LH. Refer to [MIR-16, "Removal and Installation"](#).

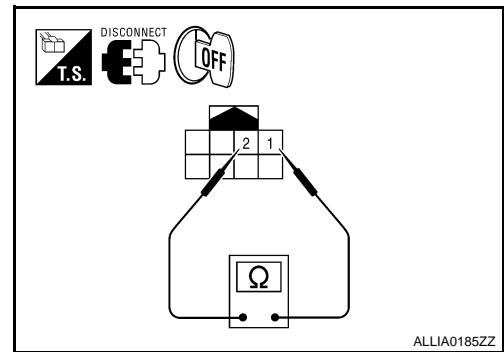

A  
B  
C  
D  
E  
F  
G  
H  
I  
J  
K  
DEF  
M  
N  
O  
P

# PASSENGER SIDE DOOR MIRROR DEFOGGER

< COMPONENT DIAGNOSIS >

## PASSENGER SIDE DOOR MIRROR DEFOGGER

### Description

INFOID:000000001502295

Heats the heating wire with the power supply from the rear window defogger relay to prevent the door mirror from fogging up.

### Component Function Check

INFOID:000000001502296

#### 1. CHECK DOOR MIRROR DEFOGGER RH

Check that the heating wire of door mirror defogger RH is heated when turning the rear window defogger switch ON.

Is the inspection result normal?

- YES >> Door mirror defogger RH is OK.
- NO >> Refer to [DEF-18. "Diagnosis Procedure"](#).

### Diagnosis Procedure

INFOID:000000001502297

#### 1. CHECK POWER SUPPLY CIRCUIT

1. Turn ignition switch OFF.
2. Disconnect door mirror RH.
3. Turn ignition switch ON.
4. Check voltage between door mirror RH connector and ground.

Terminals		(-)	Condition of rear window defogger switch	Voltage (V) (Approx.)
(+)	Terminal			
Door mirror RH connector			ON	Battery voltage
D107	1	Ground	OFF	0

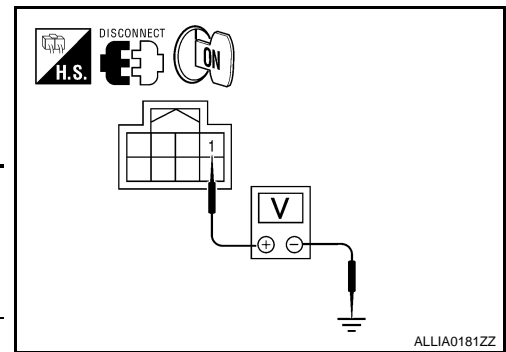

ALLIA0181ZZ

Is the inspection result normal?

- YES >> GO TO 2
- NO >> Repair or replace harness.

#### 2. CHECK GROUND CIRCUIT

1. Turn ignition switch OFF.
2. Check continuity between door mirror RH connector and ground.

Door mirror RH connector	Terminal	Ground	Continuity
D107	2		Yes

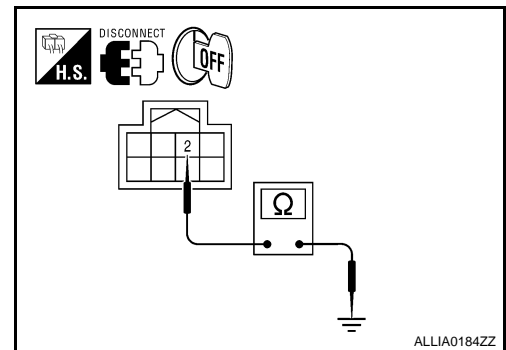

ALLIA0184ZZ

Is the inspection result normal?

- YES >> GO TO 3
- NO >> Repair or replace harness.

#### 3. CHECK PASSENGER SIDE DOOR MIRROR DEFOGGER

Check door mirror defogger RH.  
Refer to [DEF-19. "Component Inspection"](#).

Is the inspection result normal?

- YES >> GO TO 4
- NO >> Replace door mirror RH. Refer to [MIR-16. "Removal and Installation"](#).

#### 4. CHECK INTERMITTENT INCIDENT

Check intermittent incident.

# PASSENGER SIDE DOOR MIRROR DEFOGGER

## < COMPONENT DIAGNOSIS >

Refer to [GI-42. "Intermittent Incident"](#).

Is the inspection result normal?

- YES >> Check the following.
- Battery power supply circuit.
  - Fuse block (J/B).
- NO >> Repair or replace the malfunctioning parts.

## Component Inspection

INFOID:000000001502298

### 1. CHECK DOOR MIRROR DEFOGGER RH

1. Turn ignition switch OFF.
2. Disconnect door mirror RH.
3. Check continuity between door mirror terminals.

Terminal		Continuity
1	2	Yes

Is the inspection result normal?

- YES >> Inspection End.
- NO >> Replace door mirror RH. Refer to [MIR-16. "Removal and Installation"](#).

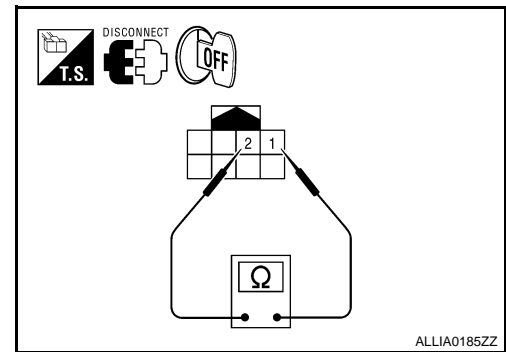

A  
B  
C  
D  
E  
F  
G  
H  
I  
J  
K  
DEF  
M  
N  
O  
P

# BCM (BODY CONTROL MODULE)

< ECU DIAGNOSIS >

## ECU DIAGNOSIS

### BCM (BODY CONTROL MODULE)

Reference Value

INFOID:000000001502299

#### VALUES ON THE DIAGNOSIS TOOL

Monitor Item	Condition	Value/Status
REAR DEF SW	<b>NOTE:</b> The item is indicated, but not monitored.	OFF

#### TERMINAL LAYOUT

Refer to [BCS-43, "Terminal Layout"](#).

#### PHYSICAL VALUES

Refer to [BCS-44, "Physical Values"](#).

# BCM (BODY CONTROL MODULE)

< ECU DIAGNOSIS >

## Wiring Diagram

INFOID:000000001502300

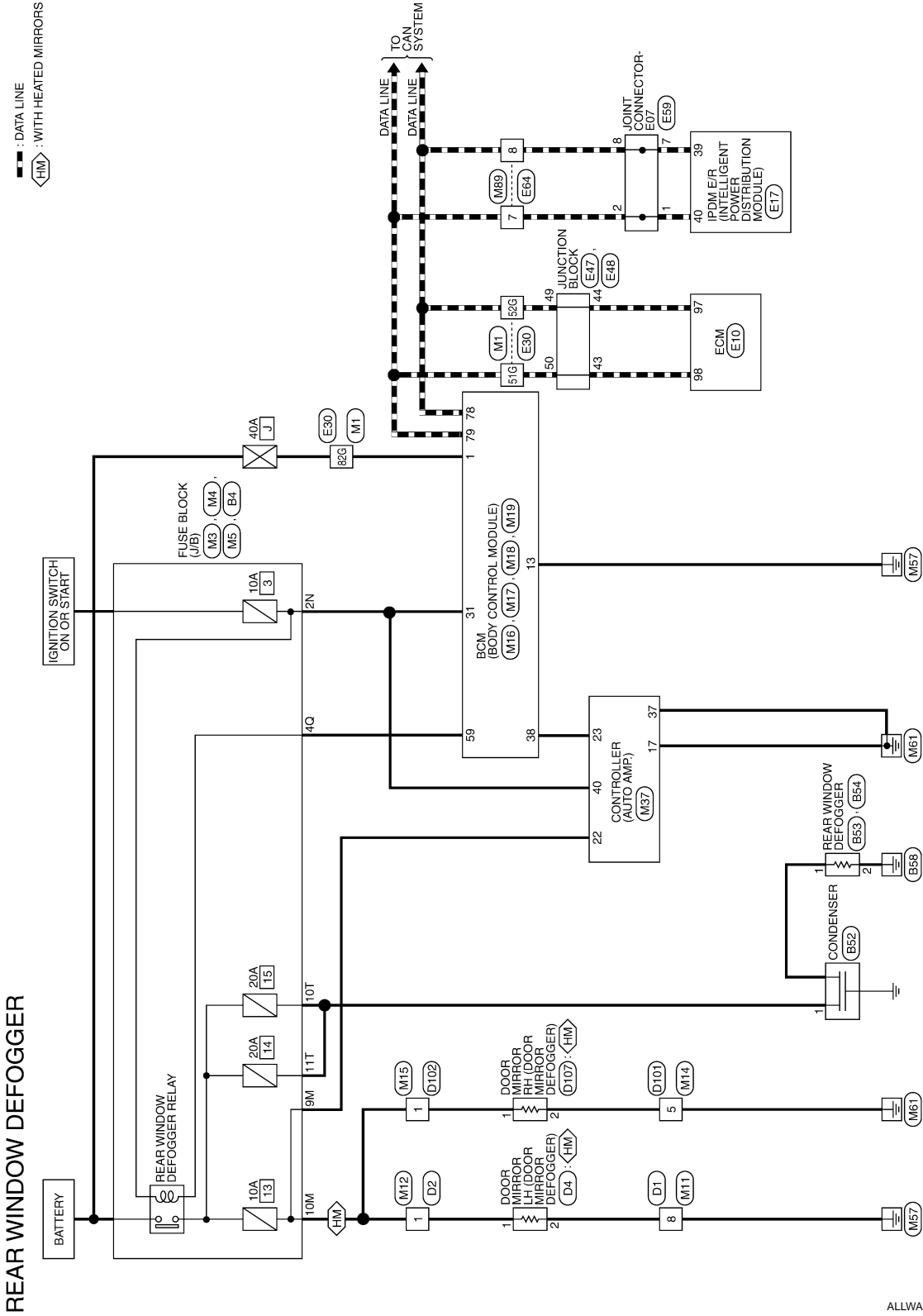

A  
B  
C  
D  
E  
F  
G  
H  
I  
J  
K  
L  
M  
N  
O  
P

DEF

# BCM (BODY CONTROL MODULE)

< ECU DIAGNOSIS >

## REAR WINDOW DEFOGGER CONNECTORS

Connector No.	M1
Connector Name	WIRE TO WIRE
Connector Color	WHITE

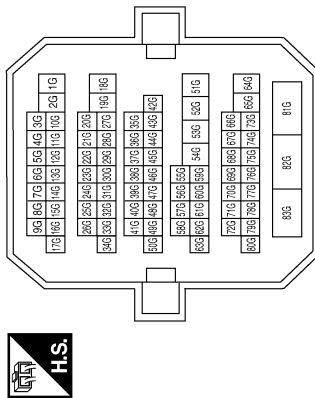

Terminal No.	Color of wire	Signal Name
51G	L	-
52G	P	-
82G	W/B	-

Connector No.	M3
Connector Name	FUSE BLOCK (J/B)
Connector Color	WHITE

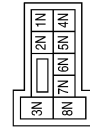

Terminal No.	2N	Color of wire	G	Signal Name	-
--------------	----	---------------	---	-------------	---

Connector No.	M4
Connector Name	FUSE BLOCK (J/B)
Connector Color	WHITE

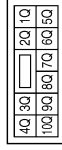

Terminal No.	4Q	Color of wire	G/R	Signal Name	-
--------------	----	---------------	-----	-------------	---

Connector No.	M5
Connector Name	FUSE BLOCK (J/B)
Connector Color	WHITE

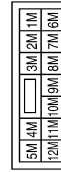

Terminal No.	9M	Color of wire	GR	Signal Name	-
10M	L/Y				-

Connector No.	M11
Connector Name	WIRE TO WIRE
Connector Color	WHITE

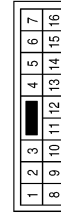

Terminal No.	8	Color of wire	B	Signal Name	-
--------------	---	---------------	---	-------------	---

Connector No.	M12
Connector Name	WIRE TO WIRE
Connector Color	WHITE

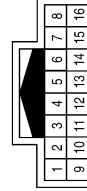

Terminal No.	1	Color of wire	L/Y	Signal Name	-
--------------	---	---------------	-----	-------------	---

ALLIA0098GB

# BCM (BODY CONTROL MODULE)

< ECU DIAGNOSIS >

Connector No.	M16
Connector Name	BCM (BODY CONTROL MODULE)
Connector Color	BLACK



Terminal No.	Color of Wire	Signal Name
1	W/B	BAT_POWER_F/L

Connector No.	M15
Connector Name	WIRE TO WIRE
Connector Color	WHITE

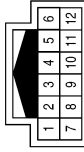

Terminal No.	Color of Wire	Signal Name
1	L/Y	—

Connector No.	M14
Connector Name	WIRE TO WIRE
Connector Color	WHITE

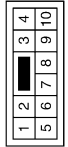

Terminal No.	Color of Wire	Signal Name
5	B	—

Connector No.	M19
Connector Name	BCM (BODY CONTROL MODULE)
Connector Color	BLACK



79	78	77	76	75	74	73	72	71	70	69	68	67	66	65	64	63	62	61	60	99	98	97	96	95	94	93	92	91	90	89	88	87	86	85	84	83	82	81	80
----	----	----	----	----	----	----	----	----	----	----	----	----	----	----	----	----	----	----	----	----	----	----	----	----	----	----	----	----	----	----	----	----	----	----	----	----	----	----	----

Terminal No.	Color of Wire	Signal Name
78	P	CAN-L
79	L	CAN-H

Connector No.	M18
Connector Name	BCM (BODY CONTROL MODULE)
Connector Color	GREEN



39	38	37	36	35	34	33	32	31	30	29	28	27	26	25	24	23	22	21	20	59	58	57	56	55	54	53	52	51	50	49	48	47	46	45	44	43	42	41	40
----	----	----	----	----	----	----	----	----	----	----	----	----	----	----	----	----	----	----	----	----	----	----	----	----	----	----	----	----	----	----	----	----	----	----	----	----	----	----	----

Terminal No.	Color of Wire	Signal Name
31	G	IGN_F/B
38	GR/W	REAR_DEFROGGER_SW
59	G/R	REAR_DEFROGGER_RLY

Connector No.	M17
Connector Name	BCM (BODY CONTROL MODULE)
Connector Color	WHITE

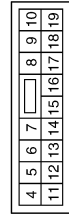

Terminal No.	Color of Wire	Signal Name
13	B	GND1

ALLIA0138GB

A  
B  
C  
D  
E  
F  
G  
H  
I  
J  
K  
DEF  
M  
N  
O  
P

# BCM (BODY CONTROL MODULE)

< ECU DIAGNOSIS >

Connector No.	E10
Connector Name	ECM
Connector Color	BLACK

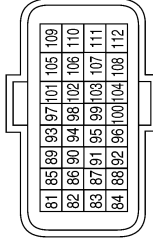

Terminal No.	Color of Wire	Signal Name
97	P	CAN-L
98	L	CAN-H

Connector No.	M89
Connector Name	WIRE TO WIRE
Connector Color	WHITE

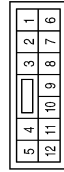

Terminal No.	Color of Wire	Signal Name
7	L	-
8	P	-

Connector No.	M37
Connector Name	CONTROLLER (AUTO AMP.)
Connector Color	WHITE

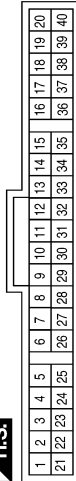

Terminal No.	Color of Wire	Signal Name
17	B	GND
22	GR	RR_DEF F/B
23	GR/W	RR_DEF ON
37	B	GND(POWER)
40	G	IGN

Connector No.	E47
Connector Name	JUNCTION BLOCK
Connector Color	WHITE

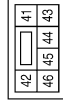

Terminal No.	Color of wire	Signal Name
43	L	-
44	P	-

Connector No.	E30
Connector Name	WIRE TO WIRE
Connector Color	WHITE

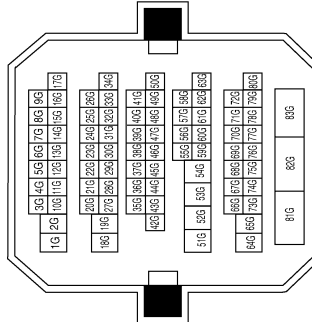

Terminal No.	Color of Wire	Signal Name
51G	L	-
52G	P	-
82G	W/B	-

Connector No.	E17
Connector Name	IPDM E/R (INTELLIGENT POWER DISTRIBUTION MODULE ENGINE ROOM)
Connector Color	WHITE

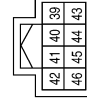

Terminal No.	Color of Wire	Signal Name
39	P	CAN-L
40	L	CAN-H

ALLIA0099GB



# BCM (BODY CONTROL MODULE)

< ECU DIAGNOSIS >

Connector No.	E64
Connector Name	WIRE TO WIRE
Connector Color	WHITE

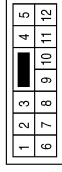

Terminal No.	Color of wire	Signal Name
7	L	-
8	P	-

Connector No.	E59
Connector Name	JOINT CONNECTOR-E07
Connector Color	BLUE

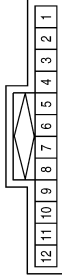

Terminal No.	Color of wire	Signal Name
1	L	-
2	L	-
7	P	-
8	P	-

Connector No.	E48
Connector Name	JUNCTION BLOCK
Connector Color	WHITE

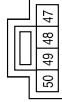

Terminal No.	Color of Wire	Signal Name
49	P	-
50	L	-

Connector No.	B53
Connector Name	REAR WINDOW DEFOGGER
Connector Color	BLACK



Terminal No.	Color of Wire	Signal Name
1	B	-

Connector No.	B52
Connector Name	CONDENSER
Connector Color	WHITE



Terminal No.	Color of Wire	Signal Name
1	R	-

Connector No.	B4
Connector Name	FUSE BLOCK (J/B)
Connector Color	BROWN



Terminal No.	Color of Wire	Signal Name
10T	R	-
11T	R	-

ALLIA0100GB

A  
B  
C  
D  
E  
F  
G  
H  
I  
J  
K  
DEF  
M  
N  
O  
P

# BCM (BODY CONTROL MODULE)

< ECU DIAGNOSIS >

Connector No.	B54
Connector Name	REAR WINDOW DEFOGGER
Connector Color	BLACK



Terminal No.	1	Color of Wire	B	Signal Name	—
--------------	---	---------------	---	-------------	---

Connector No.	D1
Connector Name	WIRE TO WIRE
Connector Color	WHITE

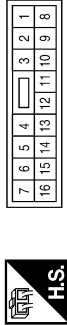

Terminal No.	8	Color of Wire	B	Signal Name	—
--------------	---	---------------	---	-------------	---

Connector No.	D2
Connector Name	WIRE TO WIRE
Connector Color	WHITE

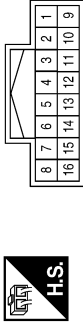

Terminal No.	1	Color of Wire	LY	Signal Name	—
--------------	---	---------------	----	-------------	---

Connector No.	D4
Connector Name	DOOR MIRROR LH
Connector Color	WHITE



Terminal No.	1	Color of Wire	G/R	Signal Name	HEATER(+)
2	B	HEATER_GND			

Connector No.	D101
Connector Name	WIRE TO WIRE
Connector Color	WHITE

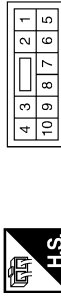

Terminal No.	5	Color of Wire	B	Signal Name	—
--------------	---	---------------	---	-------------	---

Connector No.	D102
Connector Name	WIRE TO WIRE
Connector Color	WHITE

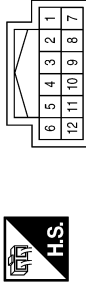

Terminal No.	1	Color of Wire	LY	Signal Name	—
--------------	---	---------------	----	-------------	---

Connector No.	D107
Connector Name	DOOR MIRROR RH
Connector Color	WHITE

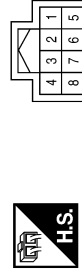

Terminal No.	1	Color of Wire	LY	Signal Name	HEATER(+)
2	B	HEATER_GND			

ALLIA0101GB

# REAR WINDOW DEFOGGER AND DOOR MIRROR DEFOGGER DO NOT OPERATE.

< SYMPTOM DIAGNOSIS >

## SYMPTOM DIAGNOSIS

REAR WINDOW DEFOGGER AND DOOR MIRROR DEFOGGER DO NOT OPERATE.

### Diagnosis Procedure

INFOID:000000001502301

#### 1. CHECK REAR WINDOW DEFOGGER SWITCH

Check rear window defogger switch.

Refer to [DEF-14, "Component Function Check"](#).

Is the inspection result normal?

YES >> GO TO 2

NO >> Repair or replace the malfunctioning parts.

#### 2. CHECK REAR WINDOW DEFOGGER RELAY

Check rear window defogger relay.

Refer to [DEF-12, "Component Function Check"](#).

Is the inspection result normal?

YES >> Refer to [GI-42, "Intermittent Incident"](#).

NO >> Repair or replace the malfunctioning parts.

A  
B  
C  
D  
E  
F  
G  
H  
I  
J  
K  
DEF  
M  
N  
O  
P

DEF

# REAR WINDOW DEFOGGER DOES NOT OPERATE BUT BOTH OF DOOR MIRROR DEFOGGER OPERATE.

< SYMPTOM DIAGNOSIS >

---

REAR WINDOW DEFOGGER DOES NOT OPERATE BUT BOTH OF DOOR MIRROR DEFOGGER OPERATE.

Diagnosis Procedure

INFOID:000000001502302

## 1. CHECK REAR WINDOW DEFOGGER POWER SUPPLY AND GROUND CIRCUIT

---

Check rear window defogger power supply and ground circuit.

Refer to [DEF-14, "Component Function Check"](#).

Is the inspection result normal?

YES >> Refer to [GI-42, "Intermittent Incident"](#).

NO >> Repair or replace the malfunctioning parts.

# BOTH DOORS MIRROR DEFOGGER DON'T OPERATE BUT REAR WINDOW DEFOGGER OPERATES

< SYMPTOM DIAGNOSIS >

## BOTH DOORS MIRROR DEFOGGER DON'T OPERATE BUT REAR WINDOW DEFOGGER OPERATES

### Diagnosis Procedure

INFOID:000000001502303

#### 1. CHECK INTERMITTENT INCIDENT

Check intermittent incident.

Refer to [GI-42, "Intermittent Incident"](#).

Is the inspection result normal?

- YES >> Check the following.
- Battery power supply circuit.
  - Fuse block (J/B).
- NO >> Repair or replace the malfunctioning parts.

A  
B  
C  
D  
E  
F  
G  
H  
I  
J  
K  
DEF  
M  
N  
O  
P

## DRIVER SIDE DOOR MIRROR DEFOGGER DOES NOT OPERATE.

< SYMPTOM DIAGNOSIS >

---

## DRIVER SIDE DOOR MIRROR DEFOGGER DOES NOT OPERATE.

### Diagnosis Procedure

INFOID:000000001502304

#### 1. CHECK DOOR MIRROR DEFOGGER LH

---

Check door mirror defogger LH.

Refer to [DEF-16, "Component Function Check"](#).

Is the inspection result normal?

YES >> Refer to [GI-42, "Intermittent Incident"](#).

NO >> Repair or replace the malfunctioning parts.

# PASSENGER SIDE DOOR MIRROR DEFOGGER DOES NOT OPERATE.

< SYMPTOM DIAGNOSIS >

## PASSENGER SIDE DOOR MIRROR DEFOGGER DOES NOT OPERATE.

### Diagnosis Procedure

INFOID:000000001502305

#### 1. CHECK DOOR MIRROR DEFOGGER RH

Check door mirror defogger RH.

Refer to [DEF-18, "Component Function Check"](#).

Is the inspection result normal?

YES >> Refer to [GI-42, "Intermittent Incident"](#).

NO >> Repair or replace the malfunctioning parts.

A  
B  
C  
D  
E  
F  
G  
H  
I  
J  
K  
DEF  
M  
N  
O  
P

DEF

# REAR WINDOW DEFOGGER SWITCH DOES NOT LIGHT, BUT REAR WINDOW DEFOGGER OPERATES

< SYMPTOM DIAGNOSIS >

---

## REAR WINDOW DEFOGGER SWITCH DOES NOT LIGHT, BUT REAR WINDOW DEFOGGER OPERATES

Diagnosis Procedure

INFOID:000000001502306

### 1. CHECK CONTROLLER (AUTO AMP.) (REAR WINDOW DEFOGGER SWITCH)

---

Check that the controller (auto amp.) (rear window defogger switch) is operating normally.

OK or NG

- OK >> Refer to [GI-42, "Intermittent Incident"](#).
- NG >> Refer to [DEF-11, "Diagnosis Procedure"](#).



# PRECAUTIONS

< PRECAUTION >

## PRECAUTION

### PRECAUTIONS

#### Supplemental Restraint System (SRS) "AIR BAG" and "SEAT BELT PRE-TENSIONER"

INFOID:000000001502307

The Supplemental Restraint System such as "AIR BAG" and "SEAT BELT PRE-TENSIONER", used along with a front seat belt, helps to reduce the risk or severity of injury to the driver and front passenger for certain types of collision. This system includes seat belt switch inputs and dual stage front air bag modules. The SRS system uses the seat belt switches to determine the front air bag deployment, and may only deploy one front air bag, depending on the severity of a collision and whether the front occupants are belted or unbelted. Information necessary to service the system safely is included in the SRS and SB section of this Service Manual.

#### **WARNING:**

- To avoid rendering the SRS inoperative, which could increase the risk of personal injury or death in the event of a collision which would result in air bag inflation, all maintenance must be performed by an authorized NISSAN/INFINITI dealer.
- Improper maintenance, including incorrect removal and installation of the SRS, can lead to personal injury caused by unintentional activation of the system. For removal of Spiral Cable and Air Bag Module, see the SRS section.
- Do not use electrical test equipment on any circuit related to the SRS unless instructed to in this Service Manual. SRS wiring harnesses can be identified by yellow and/or orange harnesses or harness connectors.

A  
B  
C  
D  
E  
F  
G  
H  
I  
J  
K  
DEF  
M  
N  
O  
P

DEF

# FILAMENT

< ON-VEHICLE REPAIR >

## ON-VEHICLE REPAIR

### FILAMENT

#### Inspection and Repair

INFOID:000000001502308

#### INSPECTION

1. When measuring voltage, wrap tin foil around the top of the negative probe. Then press the foil against the wire with your finger.

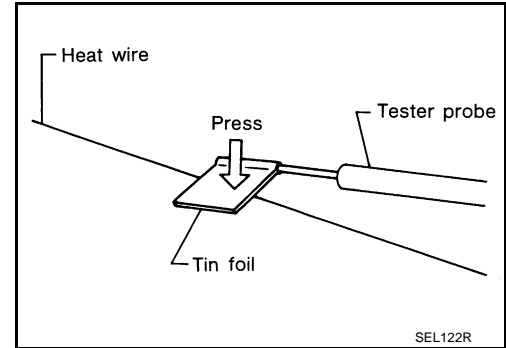

2. Attach probe circuit tester (in Volt range) to middle portion of each filament.

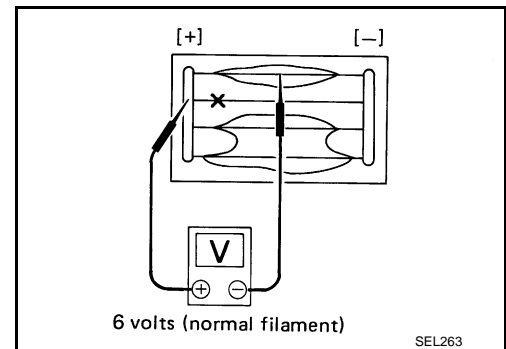

3. If a filament is burned out, circuit tester registers 0 or battery voltage.
4. To locate burned out point, move probe to left and right along filament. Test needle will swing abruptly when probe passes the point.

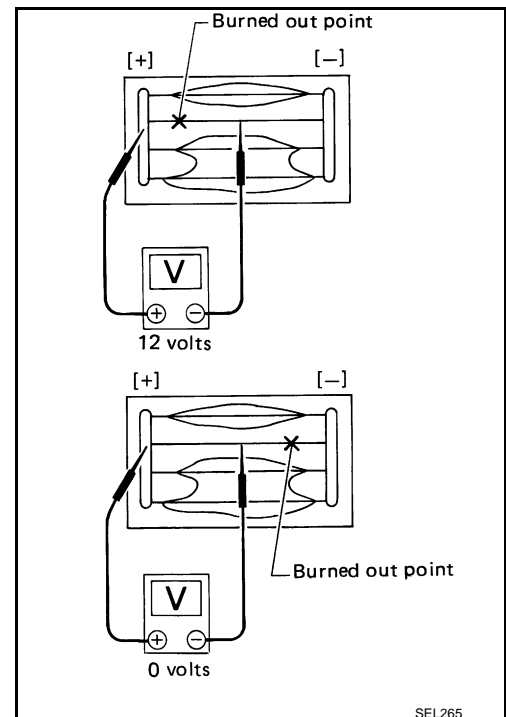

#### REPAIR

#### REPAIR EQUIPMENT

- Conductive silver composition (Dupont No. 4817 or equivalent)

# FILAMENT

## < ON-VEHICLE REPAIR >

- Ruler 30 cm (11.8 in) long
- Drawing pen
- Heat gun
- Alcohol
- Cloth

### REPAIRING PROCEDURE

1. Wipe broken heat wire and its surrounding area clean with a cloth dampened in alcohol.
2. Apply a small amount of conductive silver composition to tip of drawing pen. Shake silver composition container before use.
3. Place ruler on glass along broken line. Deposit conductive silver composition on break with drawing pen. Slightly overlap existing heat wire on both sides [preferably 5 mm (0.20 in)] of the break.

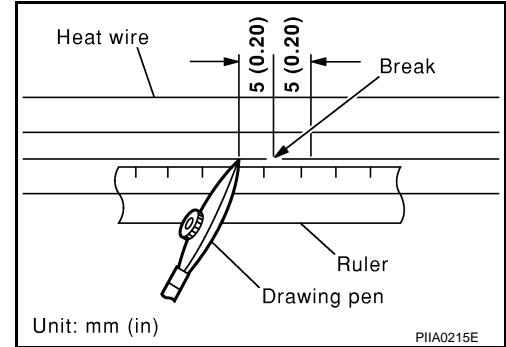

4. After repair has been completed, check repaired wire for continuity. This check should be conducted 10 minutes after silver composition is deposited. Do not touch repaired area while test is being conducted.

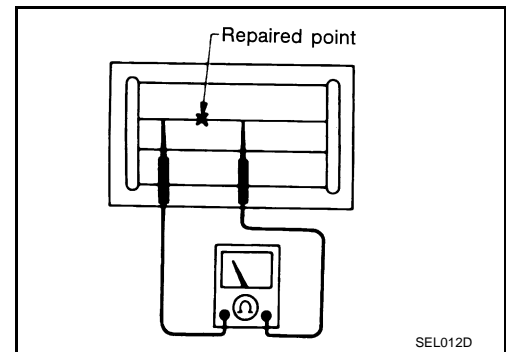

5. Apply a constant stream of hot air directly to the repaired area for approximately 20 minutes with a heat gun. A minimum distance of 3 cm (1.2 in) should be kept between repaired area and hot air outlet. If a heat gun is not available, let the repaired area dry for 24 hours.

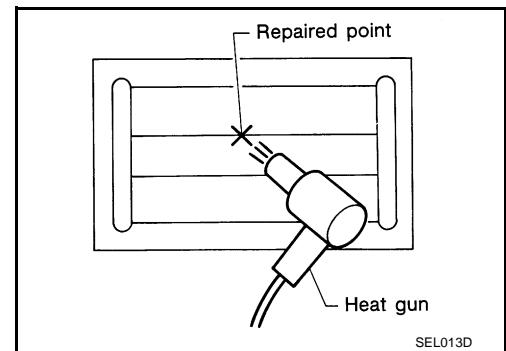

### SPECIAL REPAIR REQUIREMENT

A  
B  
C  
D  
E  
F  
G  
H  
I  
J  
K  
DEF  
M  
N  
O  
P

# CONDENSER

< ON-VEHICLE REPAIR >

## CONDENSER

### Exploded View

INFOID:000000001502309

Refer to [DEF-36, "Exploded View"](#).

### Removal and Installation

INFOID:000000001502310

#### REMOVAL

1. Remove the rear seat cushion and the rear seat back.  
Refer to [SE-20, "Removal and Installation"](#).
2. Remove the rear kickplate, rear wheel well garnish and the rear pillar finisher.  
Refer to [INT-13, "Removal and Installation"](#).
3. Remove bolt (A), and then remove condenser (1) from the vehicle body.

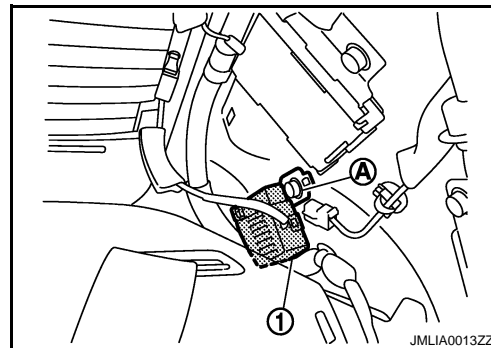

#### INSTALLATION

Install in the reverse order of removal.