

A  
STR  
C  
D  
E  
F  
G  
H  
I  
J  
K  
L  
M  
N  
O  
P

# SECTION STR

## STARTING SYSTEM

### CONTENTS

<b>QR25DE</b>	Commercial Service Tool .....18	F
<b>BASIC INSPECTION</b> ..... 3	<b>ON-VEHICLE REPAIR</b> .....19	
<b>DIAGNOSIS AND REPAIR WORKFLOW</b> ..... 3	<b>STARTER MOTOR</b> .....19	G
Work Flow .....3	Removal and Installation .....19	
<b>FUNCTION DIAGNOSIS</b> ..... 6	Removal and Installation .....19	H
<b>STARTING SYSTEM</b> ..... 6	<b>SERVICE DATA AND SPECIFICATIONS</b>	
System Diagram .....6	<b>(SDS)</b> .....20	
System Description .....6	<b>STARTER MOTOR</b> .....20	I
Component Description .....6	Starter .....20	
<b>COMPONENT DIAGNOSIS</b> ..... 8	<b>VQ35DE</b>	J
<b>B TERMINAL CIRCUIT</b> ..... 8	<b>BASIC INSPECTION</b> .....21	
Description .....8	<b>DIAGNOSIS AND REPAIR WORKFLOW</b> .....21	K
Diagnosis Procedure .....8	Work Flow .....21	
<b>S CONNECTOR CIRCUIT</b> ..... 9	<b>FUNCTION DIAGNOSIS</b> .....24	L
Description .....9	<b>STARTING SYSTEM</b> .....24	
Diagnosis Procedure .....9	System Diagram .....24	
<b>STARTING SYSTEM</b> .....10	System Description .....24	M
Wiring Diagram .....10	Component Description .....24	
<b>SYMPTOM DIAGNOSIS</b> .....16	<b>COMPONENT DIAGNOSIS</b> .....26	
<b>STARTING SYSTEM</b> .....16	<b>B TERMINAL CIRCUIT</b> .....26	N
Symptom Table .....16	Description .....26	
<b>PRECAUTION</b> .....17	Diagnosis Procedure .....26	O
<b>PRECAUTIONS</b> .....17	<b>S CONNECTOR CIRCUIT</b> .....27	
Precaution for Supplemental Restraint System	Description .....27	
(SRS) "AIR BAG" and "SEAT BELT PRE-TEN-	Diagnosis Procedure .....27	P
SIONER" .....17	<b>STARTING SYSTEM</b> .....28	
<b>PREPARATION</b> .....18	Wiring Diagram .....28	
<b>PREPARATION</b> .....18	<b>SYMPTOM DIAGNOSIS</b> .....34	
Special Service Tool .....18	<b>STARTING SYSTEM</b> .....	

Symptom Table .....	34	Commercial Service Tool .....	36
<b>PRECAUTION</b> .....	<b>35</b>	<b>ON-VEHICLE REPAIR</b> .....	<b>37</b>
<b>PRECAUTIONS</b> .....	<b>35</b>	<b>STARTER MOTOR</b> .....	<b>37</b>
Precaution for Supplemental Restraint System (SRS) "AIR BAG" and "SEAT BELT PRE-TEN- SIONER" .....	35	Removal and Installation .....	37
<b>PREPARATION</b> .....	<b>36</b>	Removal and Installation .....	37
<b>PREPARATION</b> .....	<b>36</b>	<b>SERVICE DATA AND SPECIFICATIONS</b> <b>(SDS)</b> .....	<b>39</b>
Special Service Tool .....	36	<b>STARTER MOTOR</b> .....	<b>39</b>
		Starter .....	

## BASIC INSPECTION

### DIAGNOSIS AND REPAIR WORKFLOW

#### Work Flow

INFOID:000000000990440

A

STR

#### OVERALL SEQUENCE

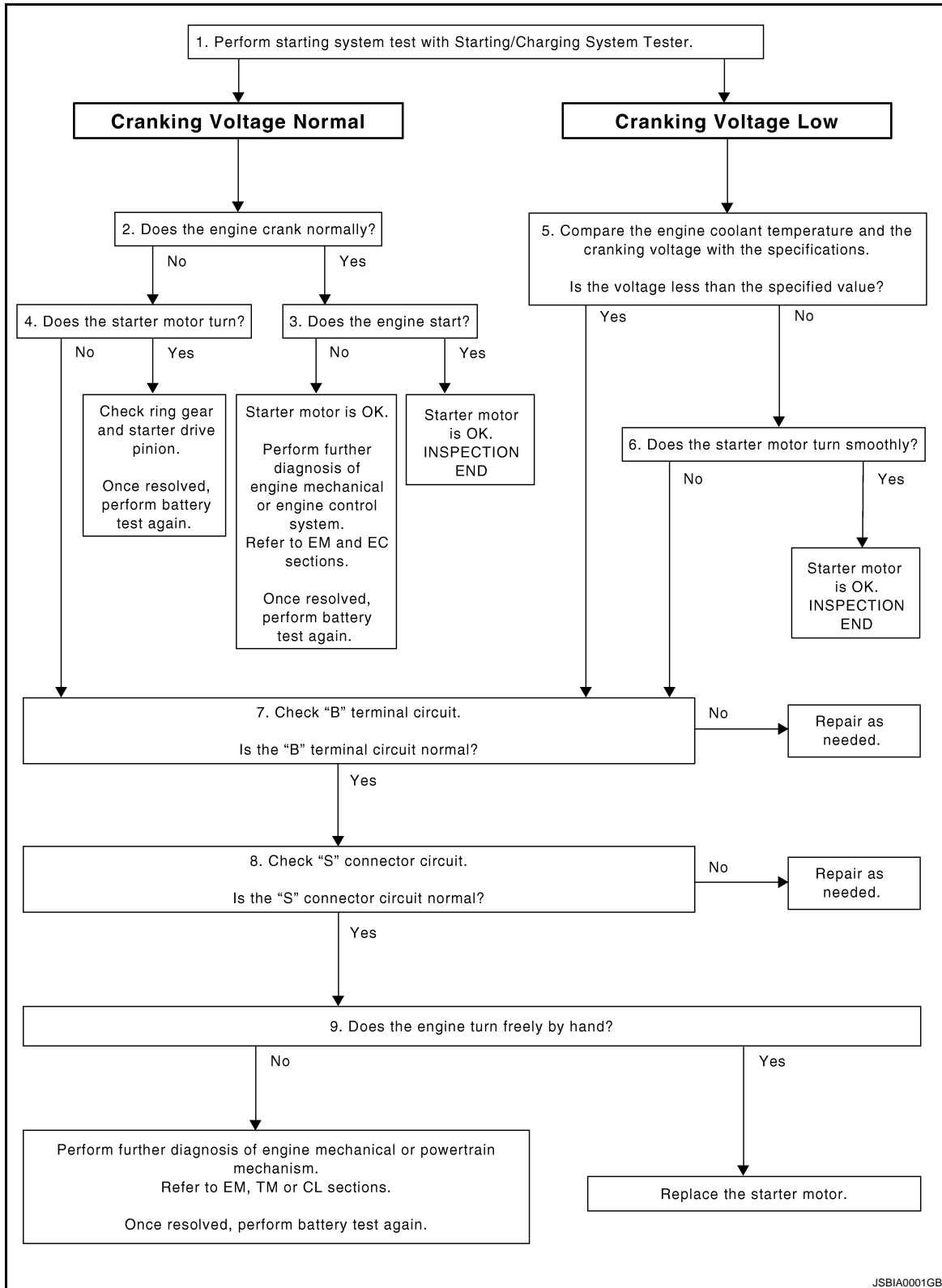

C

D

E

F

G

H

I

J

K

L

M

N

O

P

#### DETAILED FLOW

# DIAGNOSIS AND REPAIR WORKFLOW

[QR25DE]

< BASIC INSPECTION >

## NOTE:

To ensure a complete and thorough diagnosis, the battery, starter motor and alternator test segments must be done as a set from start to finish.

## 1. DIAGNOSIS WITH STARTING/CHARGING SYSTEM TESTER

Perform the starting system test with Starting/Charging System Tester (J-44373). For details and operating instructions, refer to Technical Service Bulletin.

### Test result

CRANKING VOLTAGE NORMAL>>GO TO 2..

CRANKING VOLTAGE LOW>>GO TO 5..

CHARGE BATTERY>>Perform the slow battery charging procedure. (Initial rate of charge is 10A for 12 hours.) Perform battery test again. Refer to Technical Service Bulletin.

REPLACE BATTERY>>Before replacing battery, clean the battery cable clamps and battery posts. Perform battery test again. Refer to Technical Service Bulletin. If second test result is "REPLACE BATTERY", then do so. Perform battery test again to confirm repair.

## 2. CRANKING CHECK

Check that the starter motor operates properly.

### Does the engine crank normally?

YES >> GO TO 3..

NO >> GO TO 4..

## 3. ENGINE START CHECK

Check that the engine starts.

### Does the engine start?

YES >> Starter motor is OK. Inspection end.

NO >> Perform further diagnosis of engine mechanical or engine control system. Refer to EM and EC sections. Once resolved, perform battery test again.

## 4. STARTER MOTOR ACTIVATION

Check that the starter motor operates.

### Does the starter motor turn?

YES >> Check ring gear and starter motor drive pinion. Once resolved, perform battery test again.

NO >> GO TO 7..

## 5. COMPARISON BETWEEN ENGINE COOLANT AND CRANKING VOLTAGE

Compare the engine coolant temperature and verify the cranking voltage is within specification.

Minimum Specification of Cranking Voltage Referencing Coolant Temperature

Engine coolant temperature [°C (°F)]	Voltage [V]
-30 to -20 (-22 to -4)	8.6
-19 to -10 (-2 to 14)	9.1
-9 to 0 (16 to 32)	9.5
More than 1 (More than 34)	9.9

### Is the voltage less than the specified value?

YES >> GO TO 7..

NO >> GO TO 6..

## 6. STARTER OPERATION

Check the starter operation.

### Does the starter motor turn smoothly?

YES >> Starter motor is OK. Inspection end.

NO >> GO TO 7..

## 7. "B" TERMINAL CIRCUIT INSPECTION

Check "B" terminal circuit. Refer to [STR-8, "Diagnosis Procedure"](#).

### Is "B" terminal circuit normal?

# DIAGNOSIS AND REPAIR WORKFLOW

[QR25DE]

< BASIC INSPECTION >

- YES >> GO TO 8..
- NO >> Repair as needed.

A

## 8. "S" CONNECTOR CIRCUIT INSPECTION

Check "S" connector circuit. Refer to [STR-9. "Diagnosis Procedure"](#).

Is "S" connector circuit normal?

- YES >> GO TO 9..
- NO >> Repair as needed.

C

## 9. ENGINE ROTATION STATUS

Check that the engine can be rotated by hand.

Does the engine turn freely by hand?

- YES >> Replace starter motor.
- NO >> Perform further diagnosis of engine mechanical or powertrain mechanism. Refer to EM, TM or CL sections. Once resolved, perform battery test again. Refer to Technical Service Bulletin.

D

E

F

G

H

I

J

K

L

M

N

O

P

STR

## FUNCTION DIAGNOSIS

### STARTING SYSTEM

#### System Diagram

INFOID:000000000990441

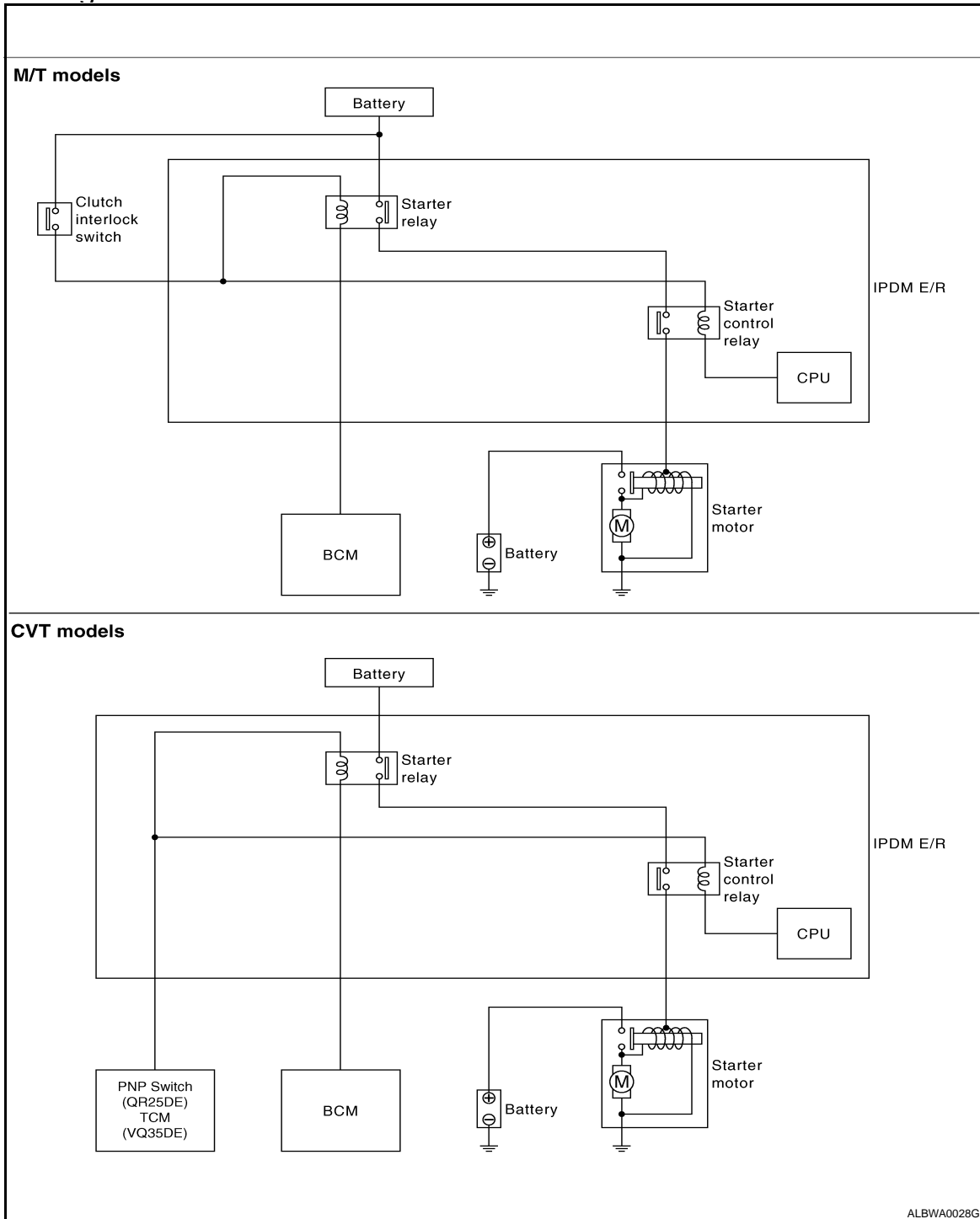

ALBWA0028G

#### System Description

INFOID:000000000990442

The starter motor plunger closes and provides a closed circuit between the battery and the starter motor. The starter motor is grounded to the cylinder block. With power and ground supplied, the starter motor operates.

#### Component Description

INFOID:000000000990443

# STARTING SYSTEM

< FUNCTION DIAGNOSIS >

[QR25DE]

Component part	Description
PNP switch (CVT models)	PNP switch supplies power to the starter relay and starter control relay inside IPDM E/R when the selector lever is shifted to the P or N position.
Clutch interlock switch (M/T models)	The switch turns ON and electric power is supplied to the starter relay and starter control relay inside IPDM E/R when the clutch pedal is depressed.
BCM	BCM controls the starter relay inside IPDM E/R.
IPDM E/R	CPU inside IPDM E/R controls the starter control relay.
Starter motor	The starter motor plunger closes and the motor is supplied with battery power, which in turn cranks the engine, when the "S" terminal is supplied with electric power.

A

STR

C

D

E

F

G

H

I

J

K

L

M

N

O

P

## COMPONENT DIAGNOSIS

### B TERMINAL CIRCUIT

#### Description

INFOID:000000000990444

The "B" terminal is constantly supplied with battery power.

#### Diagnosis Procedure

INFOID:000000000990445

#### CAUTION:

**Perform diagnosis under the condition that the engine cannot start by the following procedure.**

1. Remove fuel pump fuse.
2. Crank or start the engine (where possible) until the fuel pressure is depleted.

#### 1. CHECK TERMINAL B POWER SUPPLY VOLTAGE

1. Turn ignition switch OFF.
2. Make sure that starter motor connector F27 terminal B connection is clean and tight.
3. Check voltage between starter motor connector F27 terminal B and ground.

B - ground

Battery voltage

Is there battery voltage present?

YES >> GO TO 2..

NO >> Check harness between battery and starter motor for open circuit.

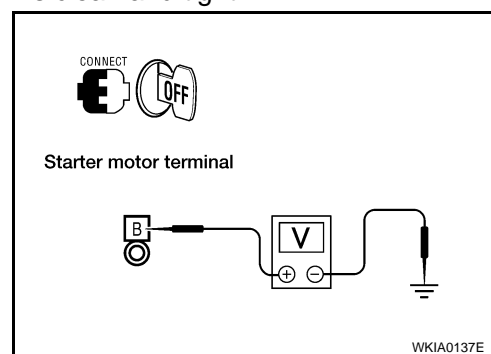

#### 2. CHECK BATTERY CABLE (VOLTAGE DROP TEST)

1. Shift CVT selector lever to "P" or "N" position. (CVT models)  
Press and hold the clutch pedal fully with the control lever in neutral. (M/T models)
2. Check voltage between battery positive terminal and starter motor connector F27 terminal B while cranking the engine.

While cranking the engine

Terminal B - B+ terminal

Less than 0.5V

Is the voltage drop less than 0.5V?

YES >> GO TO 3..

NO >> Check harness between the battery and the starter motor for high resistance.

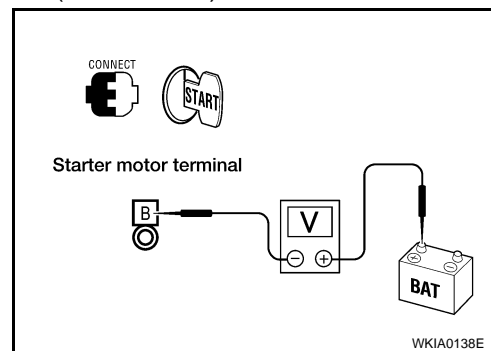

#### 3. CHECK GROUND CIRCUIT STATUS (VOLTAGE DROP TEST)

1. Shift CVT selector lever to "P" or "N" position. (CVT models)  
Press and hold the clutch pedal fully with the control lever in neutral. (M/T models)
2. Check voltage between starter motor case and battery negative terminal while cranking the engine.

While cranking the engine

Starter case - B- terminal

Less than 0.2V

Is the voltage drop less than 0.2V?

YES >> Terminal B circuit is OK. Further inspection necessary.  
Refer to [STR-3. "Work Flow"](#).

NO >> Check the starter motor case to engine mounting for high resistance.

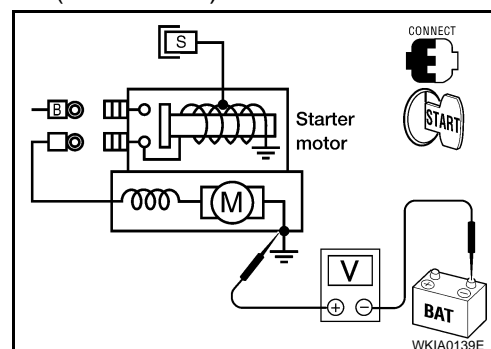



# S CONNECTOR CIRCUIT

< COMPONENT DIAGNOSIS >

[QR25DE]

## S CONNECTOR CIRCUIT

### Description

INFOID:000000000990446

The starter motor magnetic switch is supplied with power when the ignition switch is turned to the START position while the selector lever is in the P or N position (CVT models) or the clutch pedal is fully depressed (M/T models).

### Diagnosis Procedure

INFOID:000000000990447

#### CAUTION:

Perform diagnosis under the condition that engine cannot start by the following procedure.

1. Remove fuel pump fuse.
2. Crank or start the engine (where possible) until the fuel pressure is released.

#### 1. CHECK "S" CONNECTOR CIRCUIT

1. Turn ignition switch OFF.
2. Disconnect starter motor connector F28.
3. Shift CVT selector lever to "P" or "N" position. (CVT models)  
Press and hold the clutch pedal fully with the control lever in neutral. (M/T models)
4. Check voltage between starter motor harness connector F28 terminal S and ground with the ignition in START.

With ignition switch in START

S - ground

Battery voltage

Is battery voltage present?

YES >> "S" circuit is OK. Further inspection necessary. Refer to [STR-3, "Work Flow"](#).

NO >> GO TO 2..

#### 2. CHECK CONNECTOR

1. Turn ignition switch OFF.
2. Check the following terminals and connectors for damage, bent pins and loose connections.
  - IPDM E/R harness connector F10
  - Starter motor harness connector F28

Is the inspection result normal?

YES >> GO TO 3..

NO >> Repair the terminal and connector.

#### 3. CHECK HARNESS CONTINUITY (OPEN CIRCUIT)

1. Disconnect the following harness connectors.
  - IPDM E/R connector F10
  - Starter motor connector F28
2. Check continuity between starter motor harness connector F28 terminal S and IPDM E/R harness connector F10 terminal 80.

S - 80

Continuity exists

Is there proper continuity between the two pins?

YES >> Further inspection necessary. Refer to [STR-3, "Work Flow"](#).

NO >> Repair the harness.

# STARTING SYSTEM

< COMPONENT DIAGNOSIS >

[QR25DE]

## STARTING SYSTEM

### Wiring Diagram

INFOID:00000000990448

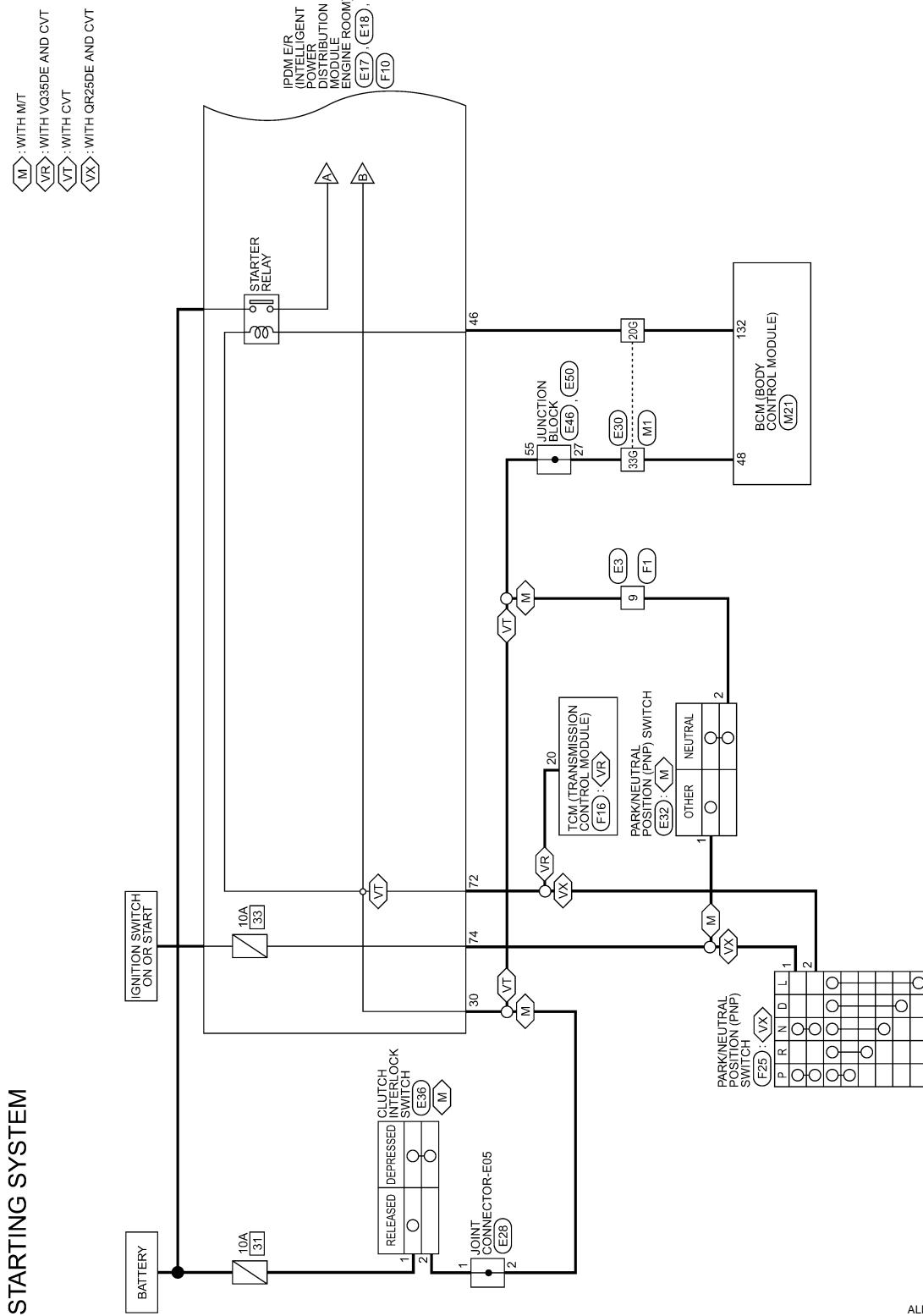

ALBWA0025GE

# STARTING SYSTEM

< COMPONENT DIAGNOSIS >

[QR25DE]

A

STR

C

D

E

F

G

H

I

J

K

L

M

N

O

P

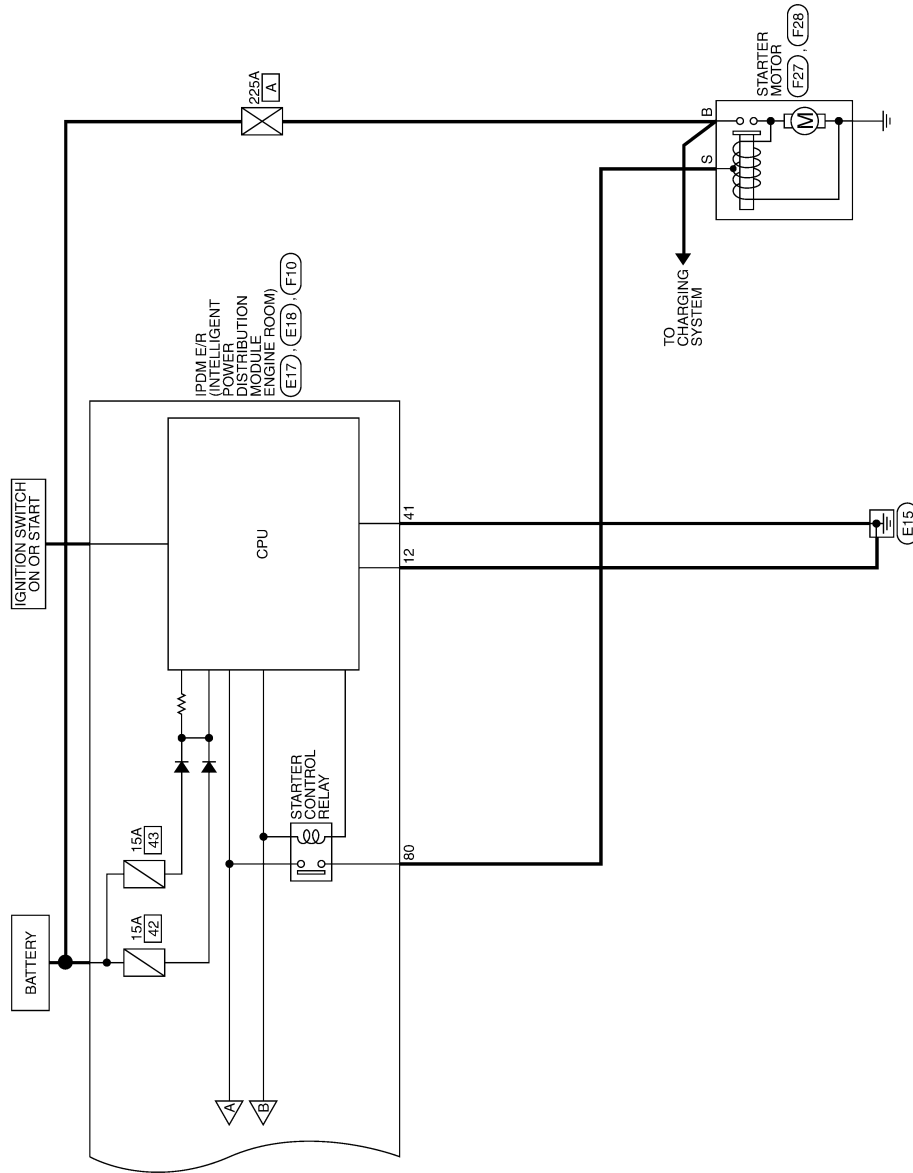

ALBWA0026GE



# STARTING SYSTEM

< COMPONENT DIAGNOSIS >

[QR25DE]

Connector No.	E28
Connector Name	JOINT CONNECTOR-E05
Connector Color	BLACK



Terminal No.	Color of Wire	Signal Name
12	B	P-GND
30	R/B	CLUTCH I/L_SW

Connector No.	E18
Connector Name	IPDM E/R (INTELLIGENT POWER DISTRIBUTION MODULE ENGINE ROOM)
Connector Color	WHITE

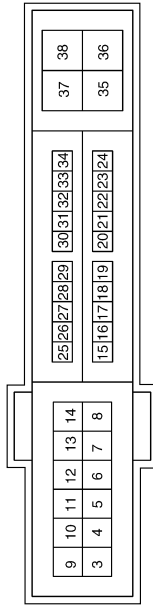

Terminal No.	Color of Wire	Signal Name
1	R/B	—
2	R/B	—

Connector No.	E46
Connector Name	JUNCTION BLOCK
Connector Color	WHITE



Connector No.	E36
Connector Name	CLUTCH INTERLOCK SWITCH
Connector Color	BROWN



Connector No.	E30
Connector Name	WIRE TO WIRE
Connector Color	WHITE

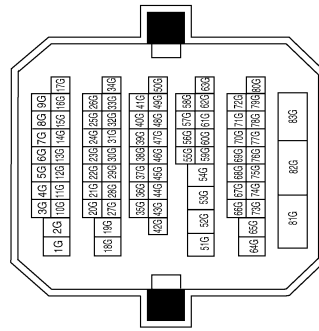

Terminal No.	Color of Wire	Signal Name
27	R/G	—

Terminal No.	Color of Wire	Signal Name
1	G/W	—
2	R/B	—

Terminal No.	Color of Wire	Signal Name
20G	R	—
33G	R/G	—

ALBIA0269GB

A  
STR  
C  
D  
E  
F  
G  
H  
I  
J  
K  
L  
M  
N  
O  
P

# STARTING SYSTEM

< COMPONENT DIAGNOSIS >

[QR25DE]

Connector No.	E50
Connector Name	JUNCTION BLOCK
Connector Color	WHITE

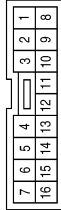

Connector No.	F1
Connector Name	WIRE TO WIRE
Connector Color	WHITE

Terminal No.	55	Color of Wire	R/B	Signal Name	—
--------------	----	---------------	-----	-------------	---

Terminal No.	9	Color of Wire	R/B	Signal Name	—
--------------	---	---------------	-----	-------------	---

Connector No.	F10
Connector Name	IPDM E/R (INTELLIGENT POWER DISTRIBUTION MODULE ENGINE ROOM)
Connector Color	WHITE

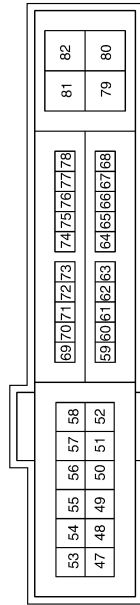

Terminal No.	72	Color of Wire	R/B	Signal Name	NPSW
Terminal No.	74	Color of Wire	Y	Signal Name	START_IG-EGI
Terminal No.	80	Color of Wire	B/W	Signal Name	STARTER MOTOR

Connector No.	F16	(QR25DE)
Connector Name	TCM (TRANSMISSION CONTROL MODULE)	
Connector Color	BLACK	

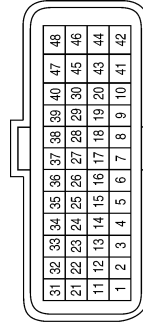

Terminal No.	20	Color of Wire	—	Signal Name	—
--------------	----	---------------	---	-------------	---

ALBIA0270GB

# STARTING SYSTEM

< COMPONENT DIAGNOSIS >

[QR25DE]

Connector No.	F27
Connector Name	STARTER MOTOR
Connector Color	—



Terminal No.	Color of Wire	Signal Name
B	B/R	BATT

Connector No.	F25
Connector Name	PARK/NEUTRAL POSITION (PNP) SWITCH (WITH QR25DE CVT)
Connector Color	BLACK

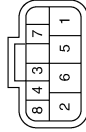

Terminal No.	Color of Wire	Signal Name
1	Y	IGN_P N
2	R/B	P_N OUTPUT

Connector No.	F16 (VQ35DE)
Connector Name	TCM (TRANSMISSION CONTROL MODULE)
Connector Color	BLACK

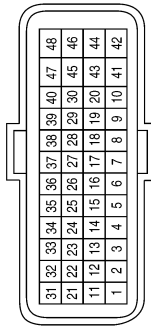

Terminal No.	Color of Wire	Signal Name
20	R/B	ST_RLY

Connector No.	F32
Connector Name	PARK/NEUTRAL POSITION (PNP) SWITCH (WITH M/T)
Connector Color	BLACK



Terminal No.	Color of Wire	Signal Name
1	Y	—
2	R/B	—

Connector No.	F28
Connector Name	STARTER MOTOR (WITH VQ35DE)
Connector Color	—



Terminal No.	Color of Wire	Signal Name
S	B/W	START

Connector No.	F28
Connector Name	STARTER MOTOR (WITH QR25DE)
Connector Color	—



Terminal No.	Color of Wire	Signal Name
S	B/W	START

ALBIA0271GB

A  
STR

C

D

E

F

G

H

I

J

K

L

M

N

O

P

# SYMPTOM DIAGNOSIS

## STARTING SYSTEM

### Symptom Table

INFOID:000000000990449

Symptom	Reference
No normal cranking	Refer to <a href="#">STR-3, "Work Flow"</a> .
Starter motor does not rotate	



# PRECAUTION

## PRECAUTIONS

### Precaution for Supplemental Restraint System (SRS) "AIR BAG" and "SEAT BELT PRE-TENSIONER"

INFOID:000000000990450

The Supplemental Restraint System such as "AIR BAG" and "SEAT BELT PRE-TENSIONER", used along with a front seat belt, helps to reduce the risk or severity of injury to the driver and front passenger for certain types of collision. This system includes seat belt switch inputs and dual stage front air bag modules. The SRS system uses the seat belt switches to determine the front air bag deployment, and may only deploy one front air bag, depending on the severity of a collision and whether the front occupants are belted or unbelted. Information necessary to service the system safely is included in the SRS and SB section of this Service Manual.

**WARNING:**

- To avoid rendering the SRS inoperative, which could increase the risk of personal injury or death in the event of a collision which would result in air bag inflation, all maintenance must be performed by an authorized NISSAN/INFINITI dealer.
- Improper maintenance, including incorrect removal and installation of the SRS, can lead to personal injury caused by unintentional activation of the system. For removal of Spiral Cable and Air Bag Module, see the SRS section.
- Do not use electrical test equipment on any circuit related to the SRS unless instructed to in this Service Manual. SRS wiring harnesses can be identified by yellow and/or orange harnesses or harness connectors.

A  
C  
D  
E  
F  
G  
H  
I  
J  
K  
L  
M  
N  
O  
P

STR

# PREPARATION

< PREPARATION >

[QR25DE]

## PREPARATION

### PREPARATION

#### Special Service Tool

INFOID:000000000990451

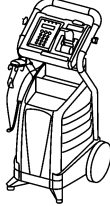
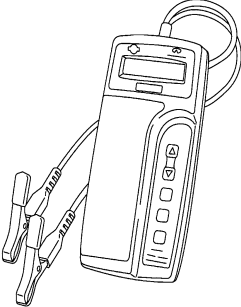
Tool number (Kent Moore No.) Tool name	Description
(J-48087) Battery Service Center  WKIA5280E	Tests Battery. For operating instructions, refer to Technical Service Bulletin and Battery Service Center User Guide.
(J-44373) Model 620 Starting/Charging system tester  SEL403X	Tests starting and charging systems. For operating instructions, refer to Technical Service Bulletin.

#### Commercial Service Tool

INFOID:000000000990452

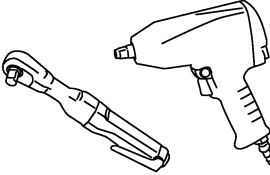
Tool name	Description
Power tool  PBIC0190E	Loosening bolts and nuts

## ON-VEHICLE REPAIR

### STARTER MOTOR

#### Removal and Installation

INFOID:000000000990453

A

STR

#### M/T MODELS

##### Removal

1. Disconnect the negative battery terminal.
2. Disconnect the starter motor harness connectors.
3. Remove the two starter motor bolts, using power tools.
4. Remove the starter motor.

##### Installation

Installation is in the reverse order of removal.

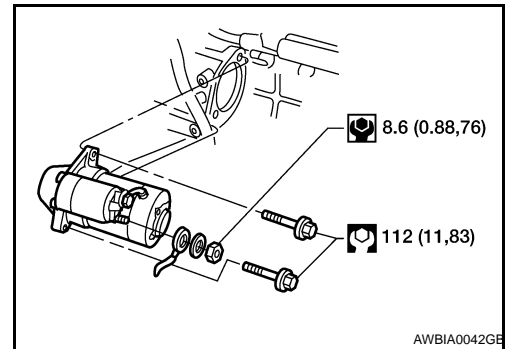

INFOID:000000000990454

#### Removal and Installation

#### CVT Models

##### REMOVAL

1. Disconnect the negative and positive battery terminal.
2. Remove the air duct (front).
3. Remove the battery and battery tray bracket.
4. Disconnect the starter harness connectors.
5. Remove the two starter bolts, using power tools.
6. Remove the starter.

##### INSTALLATION

Installation is in the reverse order of removal.

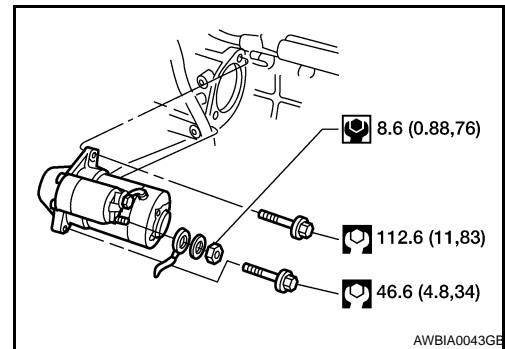

C

D

E

F

G

H

I

J

K

L

M

N

O

P

# STARTER MOTOR

< SERVICE DATA AND SPECIFICATIONS (SDS)

[QR25DE]

## SERVICE DATA AND SPECIFICATIONS (SDS)

### STARTER MOTOR

Starter

INFOID:000000000990455

Application		QR25DE	
		M/T model	CVT model
Manufacturer		Mitsubishi M001T87181ZC	Mitsubishi M001T68781ZC
Type		Reduction gear type	
System voltage		12V	
No-load	Terminal voltage	11V	
	Current	90A Max.	
	Revolution	2,750 rpm Min.	
Minimum diameter of commutator		28.8 mm	
Minimum length of brush		5.5mm	7.0 mm
Brush spring tension		15.0-20.4 N (1.53-2.08 kg, 3.37-4.59 lb)	18.3-24.8 N (1.87-2.53 kg, 4.11-5.58 lb)
Clearance between pinion front edge and pinion stopper		0.5-2.0 mm	

## BASIC INSPECTION

### DIAGNOSIS AND REPAIR WORKFLOW

#### Work Flow

INFOID:000000000990456

A

STR

#### OVERALL SEQUENCE

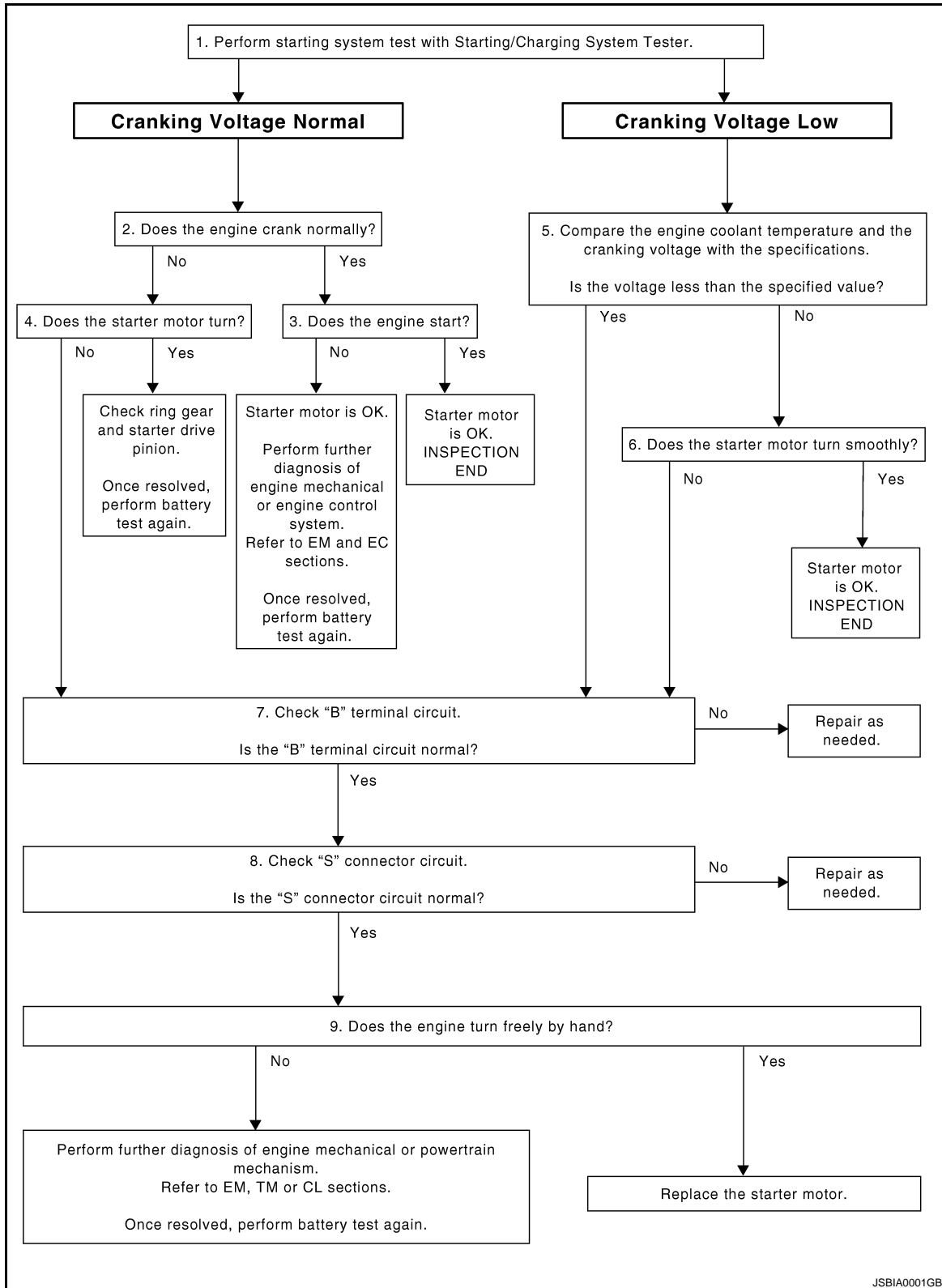

C

D

E

F

G

H

I

J

K

L

M

N

O

P

#### DETAILED FLOW

# DIAGNOSIS AND REPAIR WORKFLOW

[VQ35DE]

< BASIC INSPECTION >

## NOTE:

To ensure a complete and thorough diagnosis, the battery, starter motor and alternator test segments must be done as a set from start to finish.

## 1. DIAGNOSIS WITH STARTING/CHARGING SYSTEM TESTER

Perform the starting system test with Starting/Charging System Tester (J-44373). For details and operating instructions, refer to Technical Service Bulletin.

### Test result

CRANKING VOLTAGE NORMAL>>GO TO 2..

CRANKING VOLTAGE LOW>>GO TO 5..

CHARGE BATTERY>>Perform the slow battery charging procedure. (Initial rate of charge is 10A for 12 hours.) Perform battery test again. Refer to Technical Service Bulletin.

REPLACE BATTERY>>Before replacing battery, clean the battery cable clamps and battery posts. Perform battery test again. Refer to Technical Service Bulletin. If second test result is "REPLACE BATTERY", then do so. Perform battery test again to confirm repair.

## 2. CRANKING CHECK

Check that the starter motor operates properly.

### Does the engine crank normally?

YES >> GO TO 3..

NO >> GO TO 4..

## 3. ENGINE START CHECK

Check that the engine starts.

### Does the engine start?

YES >> Starter motor is OK. Inspection end.

NO >> Perform further diagnosis of engine mechanical or engine control system. Refer to EM and EC sections. Once resolved, perform battery test again.

## 4. STARTER MOTOR ACTIVATION

Check that the starter motor operates.

### Does the starter motor turn?

YES >> Check ring gear and starter motor drive pinion. Once resolved, perform battery test again.

NO >> GO TO 7..

## 5. COMPARISON BETWEEN ENGINE COOLANT AND CRANKING VOLTAGE

Compare the engine coolant temperature and verify the cranking voltage is within specification.

Minimum Specification of Cranking Voltage Referencing Coolant Temperature

Engine coolant temperature [°C (°F)]	Voltage [V]
-30 to -20 (-22 to -4)	8.6
-19 to -10 (-2 to 14)	9.1
-9 to 0 (16 to 32)	9.5
More than 1 (More than 34)	9.9

### Is the voltage less than the specified value?

YES >> GO TO 7..

NO >> GO TO 6..

## 6. STARTER OPERATION

Check the starter operation.

### Does the starter motor turn smoothly?

YES >> Starter motor is OK. Inspection end.

NO >> GO TO 7..

## 7. "B" TERMINAL CIRCUIT INSPECTION

Check "B" terminal circuit. Refer to [STR-26, "Diagnosis Procedure"](#).

### Is "B" terminal circuit normal?

# DIAGNOSIS AND REPAIR WORKFLOW

[VQ35DE]

< BASIC INSPECTION >

- YES >> GO TO 8..
- NO >> Repair as needed.

A

## 8. "S" CONNECTOR CIRCUIT INSPECTION

Check "S" connector circuit. Refer to [STR-27. "Diagnosis Procedure"](#).

Is "S" connector circuit normal?

- YES >> GO TO 9..
- NO >> Repair as needed.

C

## 9. ENGINE ROTATION STATUS

Check that the engine can be rotated by hand.

Does the engine turn freely by hand?

- YES >> Replace starter motor.
- NO >> Perform further diagnosis of engine mechanical or powertrain mechanism. Refer to EM, TM or CL sections. Once resolved, perform battery test again. Refer to Technical Service Bulletin.

D

E

F

G

H

I

J

K

L

M

N

O

P

STR

## FUNCTION DIAGNOSIS

### STARTING SYSTEM

#### System Diagram

INFOID:000000000990457

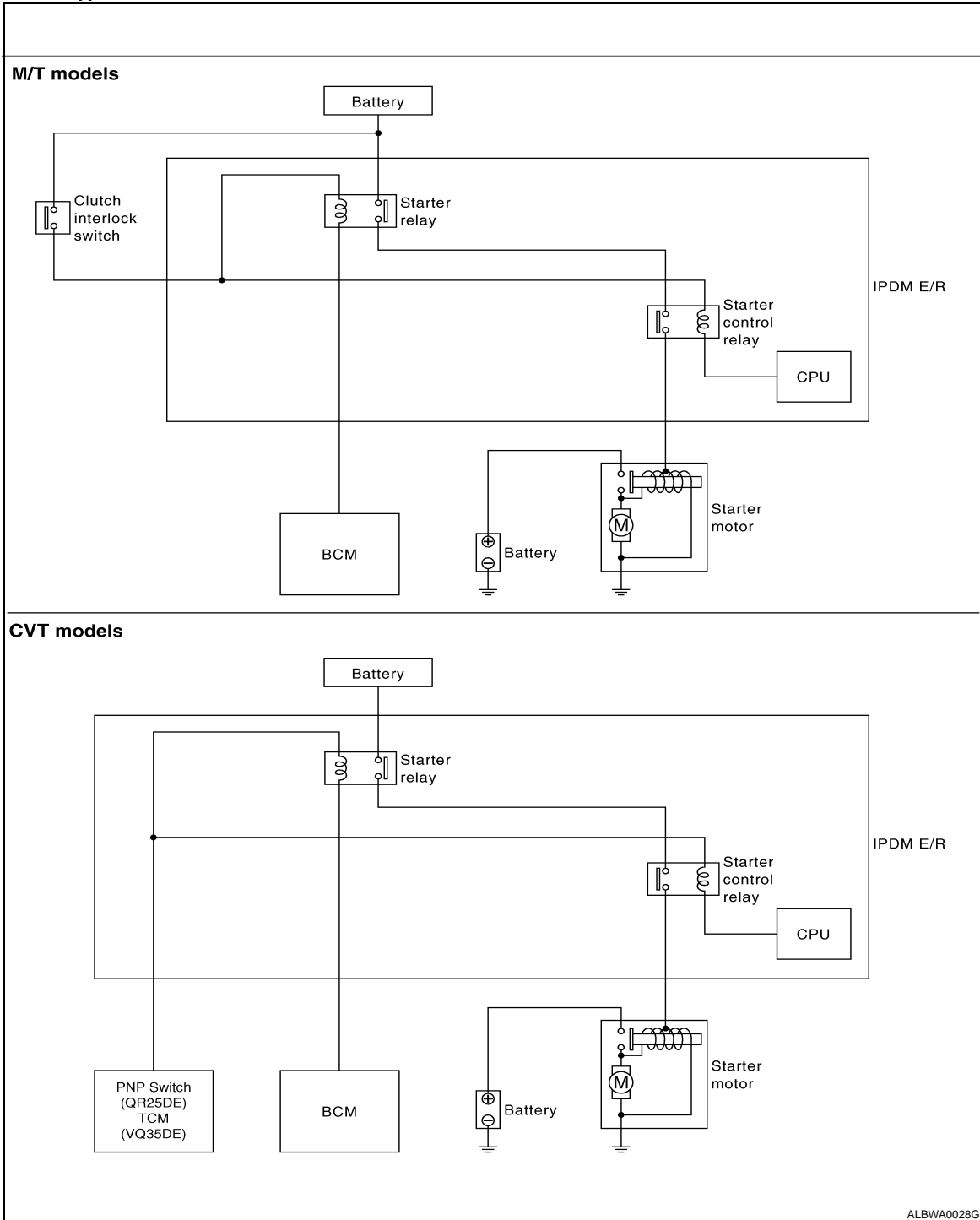

ALBWA0028G

#### System Description

INFOID:000000000990458

The starter motor plunger closes and provides a closed circuit between the battery and the starter motor. The starter motor is grounded to the cylinder block. With power and ground supplied, the starter motor operates.

#### Component Description

INFOID:000000000990459



# STARTING SYSTEM

< FUNCTION DIAGNOSIS >

[VQ35DE]

Component part	Description
TCM (CVT models)	TCM supplies power to the starter relay and starter control relay inside IPDM E/R when the selector lever is shifted to the P or N position.
Clutch interlock switch (M/T models)	The switch turns ON and electric power is supplied to the starter relay and starter control relay inside IPDM E/R when the clutch pedal is depressed.
BCM	BCM controls the starter relay inside IPDM E/R.
IPDM E/R	CPU inside IPDM E/R controls the starter control relay.
Starter motor	The starter motor plunger closes and the motor is supplied with battery power, which in turn cranks the engine, when the "S" terminal is supplied with electric power.

A

STR

C

D

E

F

G

H

I

J

K

L

M

N

O

P

## COMPONENT DIAGNOSIS

### B TERMINAL CIRCUIT

#### Description

INFOID:000000000990460

The "B" terminal is constantly supplied with battery power.

#### Diagnosis Procedure

INFOID:000000000990461

#### CAUTION:

Perform diagnosis under the condition that the engine cannot start by the following procedure.

1. Remove fuel pump fuse.
2. Crank or start the engine (where possible) until the fuel pressure is depleted.

#### 1. CHECK TERMINAL B POWER SUPPLY VOLTAGE

1. Turn ignition switch OFF.
2. Make sure that starter motor connector F27 terminal B connection is clean and tight.
3. Check voltage between starter motor connector F27 terminal B and ground.

B - ground

Battery voltage

Is there battery voltage present?

YES >> GO TO 2..

NO >> Check harness between battery and starter motor for open circuit.

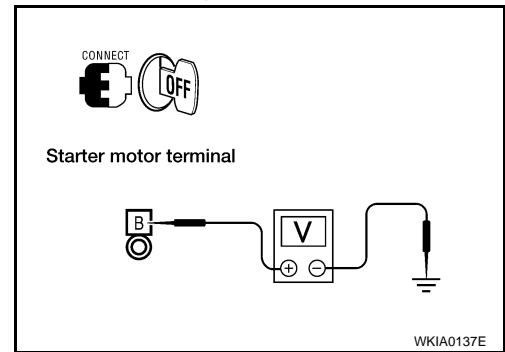

#### 2. CHECK BATTERY CABLE (VOLTAGE DROP TEST)

1. Shift CVT selector lever to "P" or "N" position. (CVT models)  
Press and hold the clutch pedal fully with the control lever in neutral. (M/T models)
2. Check voltage between battery positive terminal and starter motor connector F27 terminal B while cranking the engine.

While cranking the engine

Terminal B - B+ terminal

Less than 0.5V

Is the voltage drop less than 0.5V?

YES >> GO TO 3..

NO >> Check harness between the battery and the starter motor for high resistance.

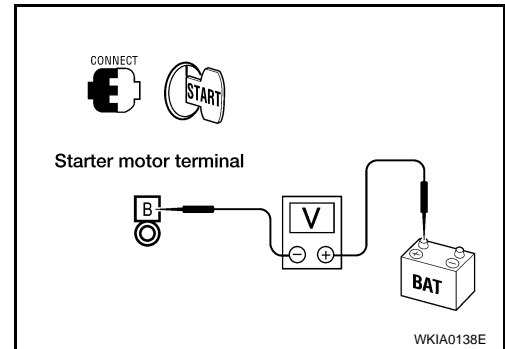

#### 3. CHECK GROUND CIRCUIT STATUS (VOLTAGE DROP TEST)

1. Shift CVT selector lever to "P" or "N" position. (CVT models)  
Press and hold the clutch pedal fully with the control lever in neutral. (M/T models)
2. Check voltage between starter motor case and battery negative terminal while cranking the engine.

While cranking the engine

Starter case - B- terminal

Less than 0.2V

Is the voltage drop less than 0.2V?

YES >> Terminal B circuit is OK. Further inspection necessary.  
Refer to [STR-21, "Work Flow"](#).

NO >> Check the starter motor case to engine mounting for high resistance.

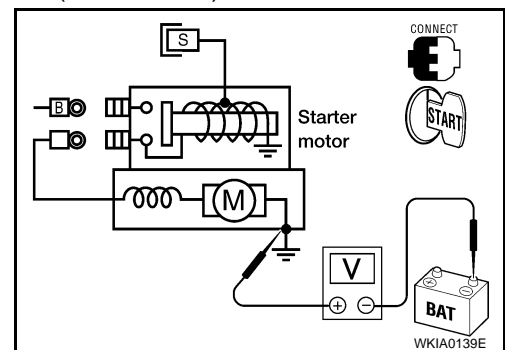

# S CONNECTOR CIRCUIT

< COMPONENT DIAGNOSIS >

[VQ35DE]

## S CONNECTOR CIRCUIT

### Description

INFOID:000000000990462

The starter motor magnetic switch is supplied with power when the ignition switch is turned to the START position while the selector lever is in the P or N position (CVT models) or the clutch pedal is fully depressed (M/T models).

### Diagnosis Procedure

INFOID:000000000990463

#### CAUTION:

Perform diagnosis under the condition that engine cannot start by the following procedure.

1. Remove fuel pump fuse.
2. Crank or start the engine (where possible) until the fuel pressure is released.

#### 1. CHECK "S" CONNECTOR CIRCUIT

1. Turn ignition switch OFF.
2. Disconnect starter motor connector F28.
3. Shift CVT selector lever to "P" or "N" position. (CVT models)  
Press and hold the clutch pedal fully with the control lever in neutral. (M/T models)
4. Check voltage between starter motor harness connector F28 terminal S and ground with the ignition in START.

With ignition switch in START

S - ground

Battery voltage

Is battery voltage present?

YES >> "S" circuit is OK. Further inspection necessary. Refer to [STR-21, "Work Flow"](#).

NO >> GO TO 2..

#### 2. CHECK CONNECTOR

1. Turn ignition switch OFF.
2. Check the following terminals and connectors for damage, bent pins and loose connections.
  - IPDM E/R harness connector F10
  - Starter motor harness connector F28

Is the inspection result normal?

YES >> GO TO 3..

NO >> Repair the terminal and connector.

#### 3. CHECK HARNESS CONTINUITY (OPEN CIRCUIT)

1. Disconnect the following harness connectors.
  - IPDM E/R connector F10
  - Starter motor connector F28
2. Check continuity between starter motor harness connector F28 terminal S and IPDM E/R harness connector F10 terminal 80.

S - 80

Continuity exists

Is there proper continuity between the two pins?

YES >> Further inspection necessary. Refer to [STR-21, "Work Flow"](#).

NO >> Repair the harness.

# STARTING SYSTEM

< COMPONENT DIAGNOSIS >

[VQ35DE]

## STARTING SYSTEM

### Wiring Diagram

INFOID:00000000999493

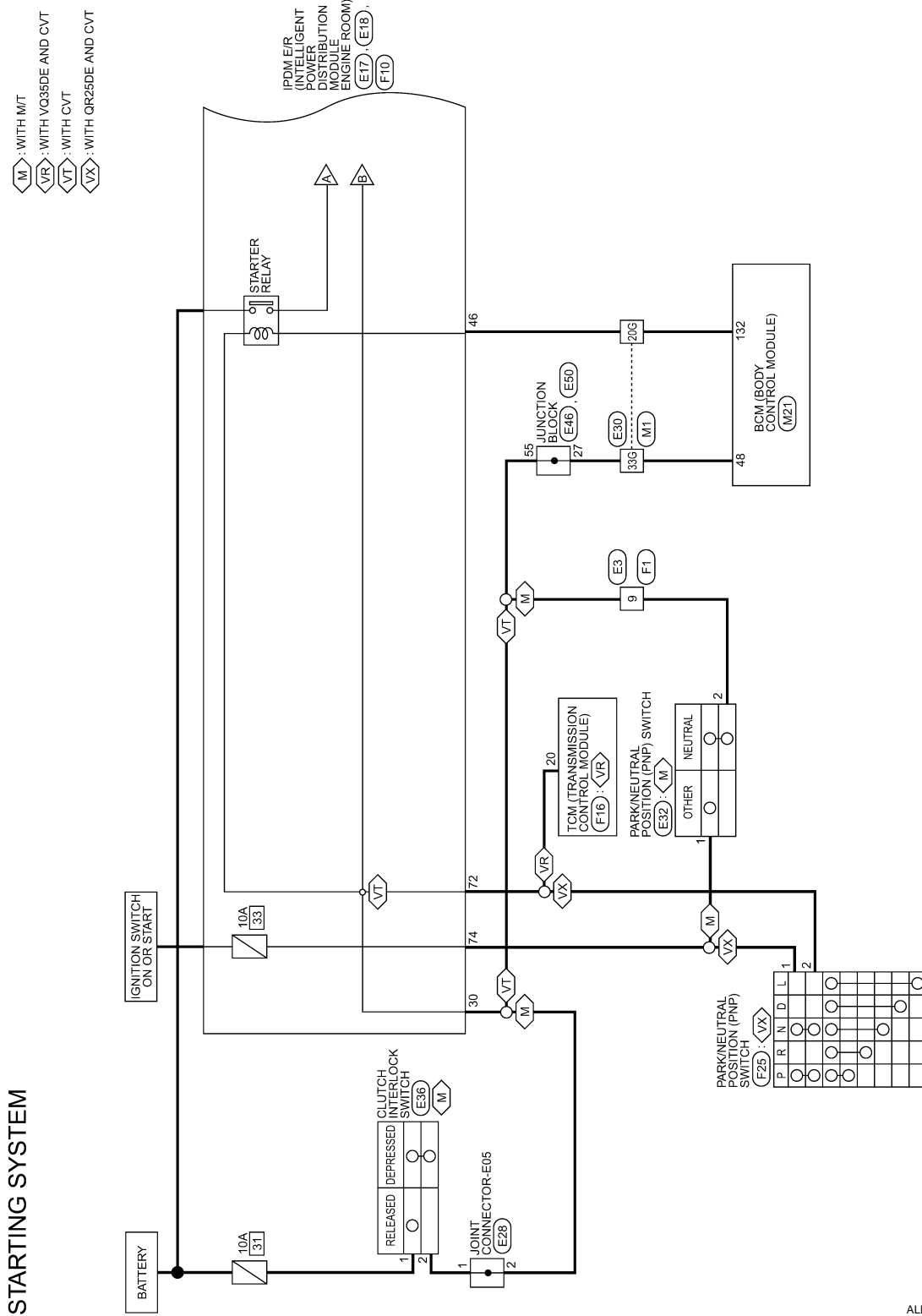

ALBWA0025GE

# STARTING SYSTEM

< COMPONENT DIAGNOSIS >

[VQ35DE]

A

STR

C

D

E

F

G

H

I

J

K

L

M

N

O

P

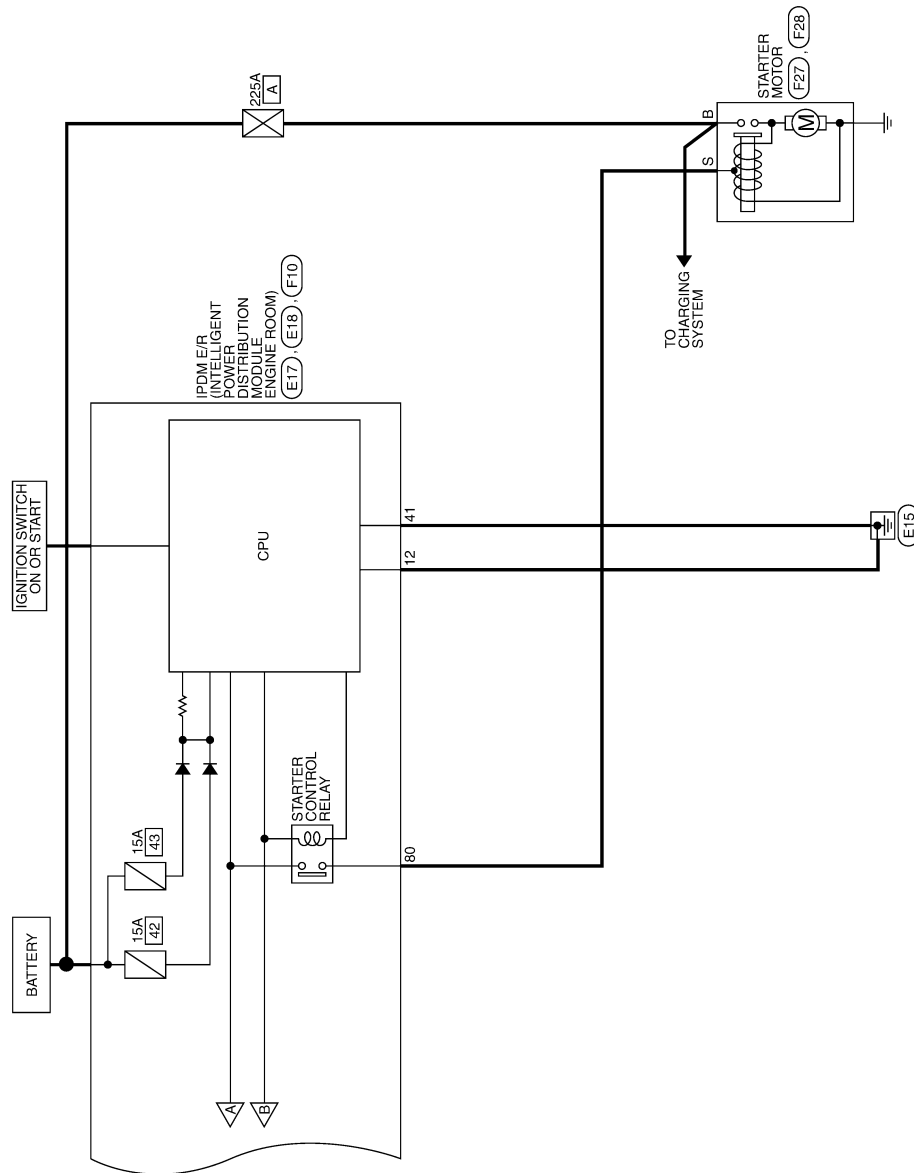

ALBWA0026GE

## STARTING SYSTEM CONNECTORS

Connector No.	M1
Connector Name	WIRE TO WIRE
Connector Color	WHITE

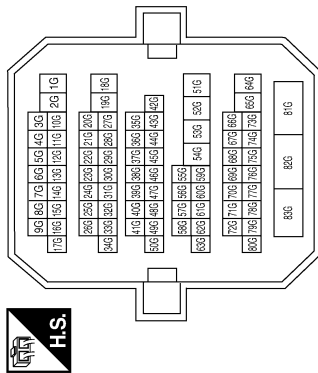

Terminal No.	Color of Wire	Signal Name
20G	R	—
33G	R/G	—

Connector No.	M18
Connector Name	BCM (BODY CONTROL MODULE)
Connector Color	GREEN

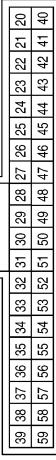

Terminal No.	Color of Wire	Signal Name
48	R/G	SHIFT N/P

Connector No.	M21
Connector Name	BCM (BODY CONTROL MODULE)
Connector Color	GRAY

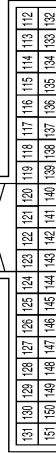

Connector No.	E3
Connector Name	WIRE TO WIRE
Connector Color	WHITE

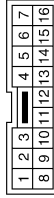

Connector No.	E17
Connector Name	IPDM E/R (INTELLIGENT POWER DISTRIBUTION MODULE ENGINE ROOM)
Connector Color	WHITE

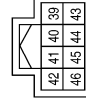

Terminal No.	Color of Wire	Signal Name
132	R	ST_CONT_USM

Terminal No.	Color of Wire	Signal Name
9	R/B	—

Terminal No.	Color of Wire	Signal Name
41	B	S-GND
46	R	START_CONT

# STARTING SYSTEM

< COMPONENT DIAGNOSIS >

[VQ35DE]

Connector No.	E28
Connector Name	JOINT CONNECTOR-E05
Connector Color	BLACK



Terminal No.	Color of Wire	Signal Name
12	B	P-GND
30	R/B	CLUTCH I/L_SW

Connector No.	E18
Connector Name	IPDM E/R (INTELLIGENT POWER DISTRIBUTION MODULE ENGINE ROOM)
Connector Color	WHITE

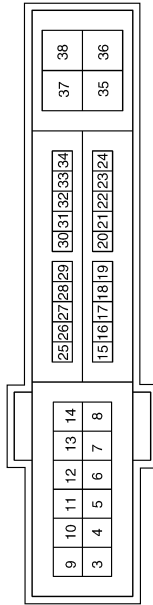

Terminal No.	Color of Wire	Signal Name
1	R/B	—
2	R/B	—

Connector No.	E46
Connector Name	JUNCTION BLOCK
Connector Color	WHITE

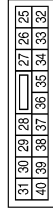

Connector No.	E36
Connector Name	CLUTCH INTERLOCK SWITCH
Connector Color	BROWN



Connector No.	E30
Connector Name	WIRE TO WIRE
Connector Color	WHITE

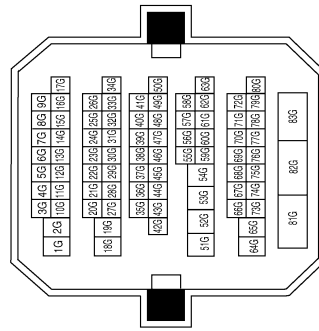

Terminal No.	Color of Wire	Signal Name
27	R/G	—

Terminal No.	Color of Wire	Signal Name
1	G/W	—
2	R/B	—

Terminal No.	Color of Wire	Signal Name
20G	R	—
33G	R/G	—

ALBIA0269GB

A  
STR  
C  
D  
E  
F  
G  
H  
I  
J  
K  
L  
M  
N  
O  
P

# STARTING SYSTEM

< COMPONENT DIAGNOSIS >

[VQ35DE]

Connector No.	E50
Connector Name	JUNCTION BLOCK
Connector Color	WHITE

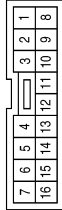

Connector No.	F1
Connector Name	WIRE TO WIRE
Connector Color	WHITE

Terminal No.	55	Color of Wire	R/B	Signal Name	—
--------------	----	---------------	-----	-------------	---

Terminal No.	9	Color of Wire	R/B	Signal Name	—
--------------	---	---------------	-----	-------------	---

Connector No.	F10
Connector Name	IPDM E/R (INTELLIGENT POWER DISTRIBUTION MODULE ENGINE ROOM)
Connector Color	WHITE

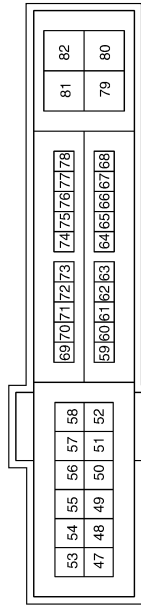

Terminal No.	72	Color of Wire	R/B	Signal Name	NPSW
Terminal No.	74	Color of Wire	Y	Signal Name	START_IG-EGI
Terminal No.	80	Color of Wire	B/W	Signal Name	STARTER MOTOR

Connector No.	F16	(QR25DE)
Connector Name	TCM (TRANSMISSION CONTROL MODULE)	
Connector Color	BLACK	

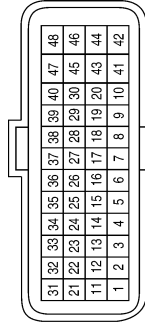

Terminal No.	20	Color of Wire	—	Signal Name	—
--------------	----	---------------	---	-------------	---



# STARTING SYSTEM

< COMPONENT DIAGNOSIS >

[VQ35DE]

Connector No.	F27
Connector Name	STARTER MOTOR
Connector Color	—



Terminal No.	Color of Wire	Signal Name
B	B/R	BATT

Connector No.	F25
Connector Name	PARK/NEUTRAL POSITION (PNP) SWITCH (WITH QR25DE CVT)
Connector Color	BLACK

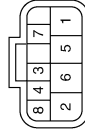

Terminal No.	Color of Wire	Signal Name
1	Y	IGN_P N
2	R/B	P_N OUTPUT

Connector No.	F16 (VQ35DE)
Connector Name	TCM (TRANSMISSION CONTROL MODULE)
Connector Color	BLACK

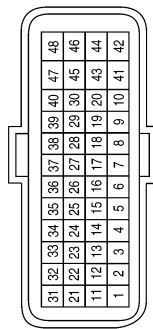

Terminal No.	Color of Wire	Signal Name
20	R/B	ST_RLY

Connector No.	F32
Connector Name	PARK/NEUTRAL POSITION (PNP) SWITCH (WITH M/T)
Connector Color	BLACK



Terminal No.	Color of Wire	Signal Name
1	Y	—
2	R/B	—

Connector No.	F28
Connector Name	STARTER MOTOR (WITH VQ35DE)
Connector Color	—



Terminal No.	Color of Wire	Signal Name
S	B/W	START

Connector No.	F28
Connector Name	STARTER MOTOR (WITH QR25DE)
Connector Color	—



Terminal No.	Color of Wire	Signal Name
S	B/W	START

ALBIA0271GB

A  
STR  
C  
D  
E  
F  
G  
H  
I  
J  
K  
L  
M  
N  
O  
P

# SYMPTOM DIAGNOSIS

## STARTING SYSTEM

### Symptom Table

INFOID:000000000990465

Symptom	Reference
No normal cranking	Refer to <a href="#">STR-21. "Work Flow"</a> .
Starter motor does not rotate	

# PRECAUTION

## PRECAUTIONS

### Precaution for Supplemental Restraint System (SRS) "AIR BAG" and "SEAT BELT PRE-TENSIONER"

INFOID:000000000990466

The Supplemental Restraint System such as "AIR BAG" and "SEAT BELT PRE-TENSIONER", used along with a front seat belt, helps to reduce the risk or severity of injury to the driver and front passenger for certain types of collision. This system includes seat belt switch inputs and dual stage front air bag modules. The SRS system uses the seat belt switches to determine the front air bag deployment, and may only deploy one front air bag, depending on the severity of a collision and whether the front occupants are belted or unbelted. Information necessary to service the system safely is included in the SRS and SB section of this Service Manual.

**WARNING:**

- To avoid rendering the SRS inoperative, which could increase the risk of personal injury or death in the event of a collision which would result in air bag inflation, all maintenance must be performed by an authorized NISSAN/INFINITI dealer.
- Improper maintenance, including incorrect removal and installation of the SRS, can lead to personal injury caused by unintentional activation of the system. For removal of Spiral Cable and Air Bag Module, see the SRS section.
- Do not use electrical test equipment on any circuit related to the SRS unless instructed to in this Service Manual. SRS wiring harnesses can be identified by yellow and/or orange harnesses or harness connectors.

A  
C  
D  
E  
F  
G  
H  
I  
J  
K  
L  
M  
N  
O  
P

STR

# PREPARATION

< PREPARATION >

[VQ35DE]

## PREPARATION

### PREPARATION

#### Special Service Tool

INFOID:000000000990467

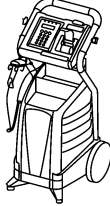
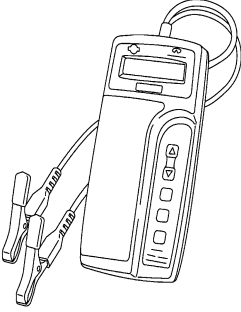
Tool number (Kent Moore No.) Tool name	Description
(J-48087) Battery Service Center  WKIA5280E	Tests Battery. For operating instructions, refer to Technical Service Bulletin and Battery Service Center User Guide.
(J-44373) Model 620 Starting/Charging system tester  SEL403X	Tests starting and charging systems. For operating instructions, refer to Technical Service Bulletin.

#### Commercial Service Tool

INFOID:000000000990468

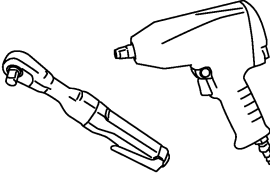
Tool name	Description
Power tool  PBIC0190E	Loosening bolts and nuts

## ON-VEHICLE REPAIR

### STARTER MOTOR

#### Removal and Installation

INFOID:000000000990469

STR

#### M/T Models

##### REMOVAL

1. Disconnect the negative battery terminal.
2. Disconnect the starter motor harness connectors.
3. Remove the two starter motor bolts, using power tools.
4. Remove the starter motor.

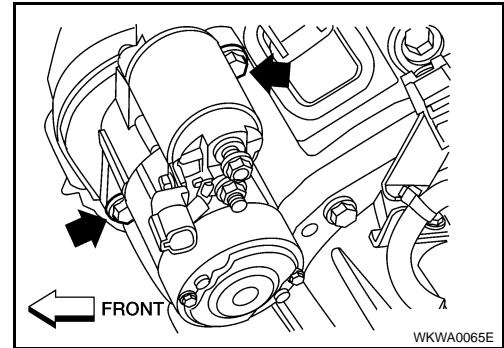

##### INSTALLATION

Installation is in the reverse order of removal.

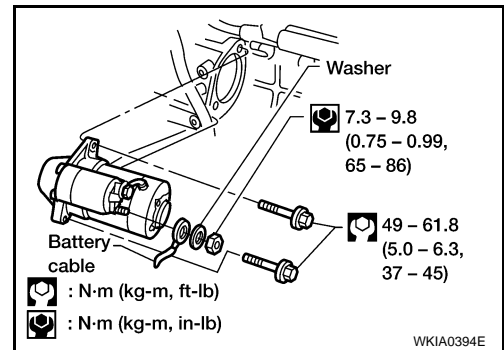

#### Removal and Installation

INFOID:000000000990470

#### CVT Models

##### REMOVAL

1. Disconnect the negative and positive battery terminal.
2. Remove the air cleaner assembly and air ducts.
3. Disconnect the following:
  - ECM
  - CVT control unit (if equipped)
  - IPDM/ER
4. Remove the battery tray.
5. Disconnect the starter harness connectors.
6. Remove the two starter bolts, using power tools.
7. Remove the starter.

##### INSTALLATION

A  
C  
D  
E  
F  
G  
H  
I  
J  
K  
L  
M  
N  
O  
P

# STARTER MOTOR

[VQ35DE]

< ON-VEHICLE REPAIR >

Installation is in the reverse order of removal.

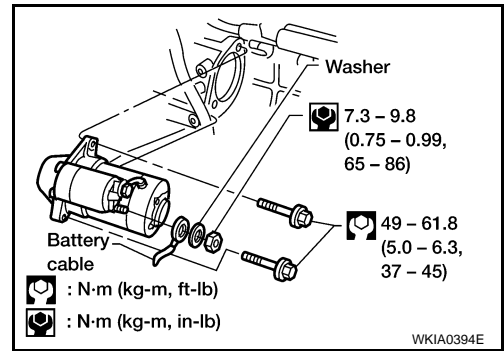

# STARTER MOTOR

< SERVICE DATA AND SPECIFICATIONS (SDS)

[VQ35DE]

## SERVICE DATA AND SPECIFICATIONS (SDS)

### STARTER MOTOR

#### Starter

INFOID:000000000990471

A

STR

Application		VQ35DE	
		M/T model	CVT model
Manufacturer		Mitsubishi M000T87281ZC	Mitsubishi M000T87181ZC
Type		Reduction gear type	
System voltage		12V	
No-load	Terminal voltage	11V	
	Current	90A Max.	
	Revolution	2,800 rpm Min.	
Minimum diameter of commutator		28.8 mm	
Minimum length of brush		7.0 mm	
Brush spring tension		18.3-24.8 N (1.87-2.53 kg, 4.11-5.58 lb)	
Clearance between pinion front edge and pinion stopper		0.5-2.0 mm	

C

D

E

F

G

H

I

J

K

L

M

N

O

P