

A
B
C

SECTION **SRS**

SRS AIRBAG SYSTEM

CONTENTS

<p>PRECAUTION 2</p> <p>PRECAUTIONS 2</p> <p style="padding-left: 20px;">Supplemental Restraint System (SRS) "AIR BAG" and "SEAT BELT PRE-TENSIONER"2</p> <p style="padding-left: 20px;">Service2</p> <p style="padding-left: 20px;">Occupant Classification System2</p> <p>PREPARATION 3</p> <p>PREPARATION 3</p> <p style="padding-left: 20px;">Special Service Tool3</p> <p style="padding-left: 20px;">Commercial Service Tools3</p> <p>ON-VEHICLE REPAIR 4</p> <p>DRIVER AIR BAG MODULE 4</p> <p style="padding-left: 20px;">Exploded View4</p> <p style="padding-left: 20px;">Removal and Installation4</p> <p>SPIRAL CABLE 6</p> <p style="padding-left: 20px;">Removal and Installation6</p> <p>FRONT PASSENGER AIR BAG MODULE 8</p> <p style="padding-left: 20px;">Removal and Installation8</p>	<p>SIDE CURTAIN AIR BAG MODULE10</p> <p style="padding-left: 20px;">Exploded View10</p> <p style="padding-left: 20px;">Removal and Installation10</p> <p>CRASH ZONE SENSOR12</p> <p style="padding-left: 20px;">Exploded View12</p> <p style="padding-left: 20px;">Removal and Installation12</p> <p>SIDE AIR BAG (SATELLITE) SENSOR13</p> <p style="padding-left: 20px;">Exploded View13</p> <p style="padding-left: 20px;">Removal and Installation13</p> <p>DIAGNOSIS SENSOR UNIT14</p> <p style="padding-left: 20px;">Exploded View14</p> <p style="padding-left: 20px;">Removal and Installation14</p> <p>OCCUPANT CLASSIFICATION SYSTEM CONTROL UNIT16</p> <p style="padding-left: 20px;">Removal and Installation16</p> <p>COLLISION DIAGNOSIS17</p> <p style="padding-left: 20px;">For Frontal Collision17</p> <p style="padding-left: 20px;">For Side and Rollover Collision18</p>	<p>D E F G H I J K L M N O P</p>
------------------------------------------------------------------------------------------------------------------------------------------------------------------------------------------------------------------------------------------------------------------------------------------------------------------------------------------------------------------------------------------------------------------------------------------------------------------------------------------------------------------------------------------------------------------------------------------------------------------------------------------------------------------------------------------------------------------------------------------------------------------------------------------------------------------------------------------------------------------------------------------------------------------------------------------------------------------------	---------------------------------------------------------------------------------------------------------------------------------------------------------------------------------------------------------------------------------------------------------------------------------------------------------------------------------------------------------------------------------------------------------------------------------------------------------------------------------------------------------------------------------------------------------------------------------------------------------------------------------------------------------------------------------------------------------------------------------------------------------------------------------------------------------------------------------------------------------------------------------------------------------------------------------------------------------------------------------------------------------------------------------------------	----------------------------------------------------------------------------------

SRS

PRECAUTIONS

< PRECAUTION >

PRECAUTION

PRECAUTIONS

Supplemental Restraint System (SRS) "AIR BAG" and "SEAT BELT PRE-TENSIONER"

INFOID:000000000992974

The Supplemental Restraint System such as "AIR BAG" and "SEAT BELT PRE-TENSIONER", used along with a front seat belt, helps to reduce the risk or severity of injury to the driver and front passenger for certain types of collision. This system includes seat belt switch inputs and dual stage front air bag modules. The SRS system uses the seat belt switches to determine the front air bag deployment, and may only deploy one front air bag, depending on the severity of a collision and whether the front occupants are belted or unbelted. Information necessary to service the system safely is included in the SRS and SB section of this Service Manual.

WARNING:

- To avoid rendering the SRS inoperative, which could increase the risk of personal injury or death in the event of a collision which would result in air bag inflation, all maintenance must be performed by an authorized NISSAN/INFINITI dealer.
- Improper maintenance, including incorrect removal and installation of the SRS, can lead to personal injury caused by unintentional activation of the system. For removal of Spiral Cable and Air Bag Module, see the SRS section.
- Do not use electrical test equipment on any circuit related to the SRS unless instructed to in this Service Manual. SRS wiring harnesses can be identified by yellow and/or orange harnesses or harness connectors.

Service

INFOID:000000000992975

- Do not use electrical test equipment to check SRS circuits unless instructed to in this Service Manual.
- Before servicing the SRS, turn ignition switch OFF, disconnect both battery cables and wait at least 3 minutes.
For approximately 3 minutes after the cables are removed, it is still possible for the air bag and seat belt pretensioner to deploy. Therefore, do not work on any SRS connectors or wires until at least 3 minutes have passed.
- Diagnosis sensor unit must always be installed with their arrow marks "⇐" pointing towards the front of the vehicle for proper operation. Also check diagnosis sensor unit for cracks, deformities or rust before installation and replace as required.
- The spiral cable must be aligned with the neutral position since its rotations are limited. Do not turn steering wheel and column after removal of steering gear.
- Handle air bag module carefully. Always place driver and front passenger air bag modules with the pad side facing upward and seat mounted front side air bag module standing with the stud bolt side facing down.
- Conduct self-diagnosis to check entire SRS for proper function after replacing any components.
- After air bag inflates, the front instrument panel assembly should be replaced if damaged.
- Always replace instrument panel pad following front passenger air bag deployment.

Occupant Classification System

INFOID:000000000992976

- Replace occupant classification system control unit and passenger front seat cushion as an assembly. Refer to [SE-25, "PASSENGER SIDE : Disassembly"](#).

PREPARATION

< PREPARATION >

PREPARATION

PREPARATION

Special Service Tool

INFOID:000000000992977

The actual shapes of Kent-Moore tools may differ from those of special service tools illustrated here.

Tool number (Kent-Moore No.) Tool name	Description
<p>— (J-44615) Air bag lock master key set</p>  <p>LRS191</p>	<p>Removing and installing air bag lock</p>

Commercial Service Tools

INFOID:000000000992978

Tool name	Description
<p>Power tools</p>  <p>PIIB1407E</p>	<p>Loosening bolts, nuts and screws</p>

A
B
C
D
E
F
G
I
J
K
L
M
N
O
P

SRS

DRIVER AIR BAG MODULE

< ON-VEHICLE REPAIR >

ON-VEHICLE REPAIR

DRIVER AIR BAG MODULE

Exploded View

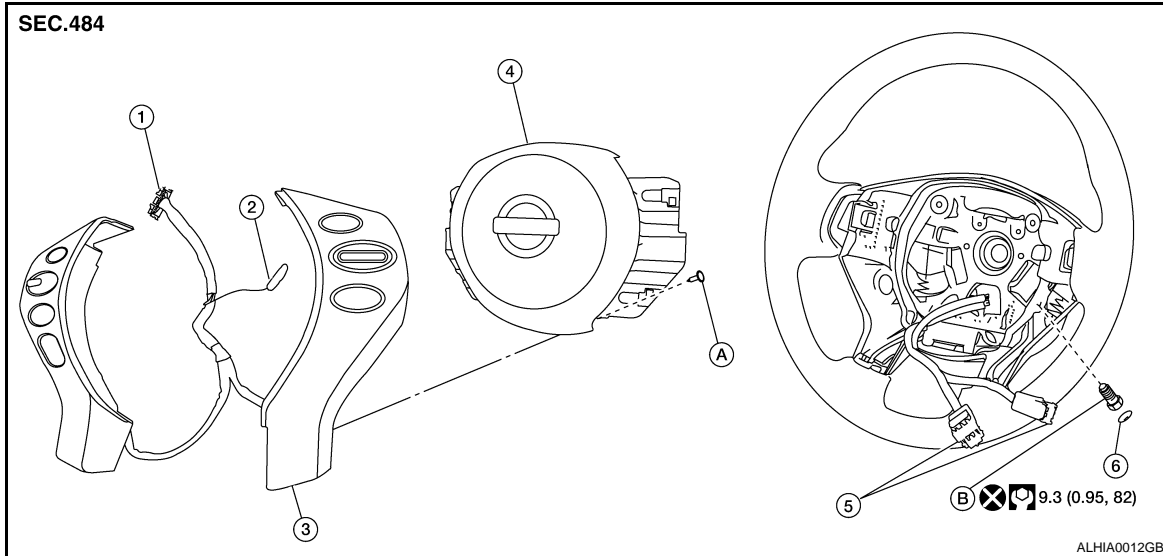

- | | | |
|------------------------------|---------------------------------------|----------------------|
| 1. Steering switch connector | 2. Steering switch ground connector | 3. Steering switches |
| 4. Driver air bag module | 5. Driver air bag module connectors | 6. Side lid (RH/LH) |
| A. Steering switch screw | B. Driver air bag module bolt (RH/LH) | |

Removal and Installation

INFOID:000000000992980

REMOVAL

CAUTION:

- Before servicing, turn ignition switch OFF, disconnect both battery terminal and wait at least 3 minutes.
- Do not use air tools or electric tools for servicing.
- Always work from the side of air bag module. Do not work from the front of it.
- Always place air bag module with pad side facing upward.
- Do not use old bolts after removal; replace with new bolts.
- Do not cause impact to the air bag module by dropping etc. Replace the air bag module if it has been dropped or sustained an impact.

1. Disconnect the negative and positive battery cables, then wait at least 3 minutes.
2. Remove side lids, then remove the driver air bag module bolts (RH/LH).
3. Raise driver air bag module away from the steering wheel, then disconnect the steering switch.
4. Disconnect the driver air bag module connectors, then remove driver air bag module from steering wheel.
 - For installing/removing direct-connect SRS connectors, refer to [SRC-8, "Direct-connect SRS Component Connectors"](#).

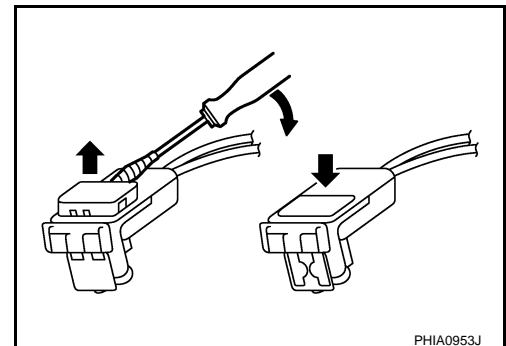

DRIVER AIR BAG MODULE

< ON-VEHICLE REPAIR >

5. Disconnect the steering switch ground connector (1), then release the harness (2) from the clips.
6. Remove the steering switch screws (RH/LH) (1), then remove the steering switches from driver air bag module.

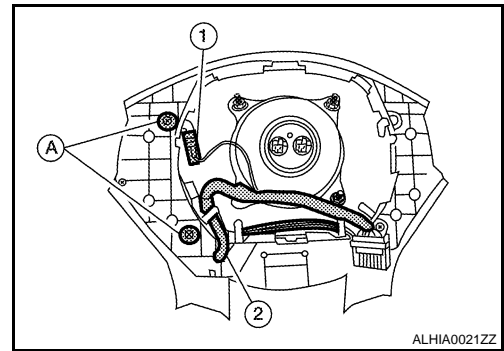

INSTALLATION

Installation is in the reverse order of removal.

CAUTION:

- Be careful not to damage the harness while installing.
- Tighten the driver air bag module bolts after centering the holes between the driver air bag module and the steering wheel horn contact bracket. If the holes are misaligned, the bolt threads may become damaged and the module will not install securely.
- After the work is completed, make sure no system malfunction is detected by air bag warning lamp.
- In case a malfunction is detected by the air bag warning lamp, reset by the self-diagnosis function and delete the memory by CONSULT-III.
- If a malfunction is still detected after the above operation, perform self-diagnosis to repair malfunctions. Refer to [SRC-12. "SRS Operation Check"](#).

A
B
C
D
E
F
G
I
J
K
L
M
N
O
P

SRS

SPIRAL CABLE

< ON-VEHICLE REPAIR >

SPIRAL CABLE

Removal and Installation

INFOID:00000000992981

REMOVAL

CAUTION:

- Before servicing, turn ignition switch OFF, disconnect both battery terminal and wait at least 3 minutes.
 - Do not use air tools or electric tools for servicing.
 - Do not disassemble the spiral cable.
 - Do not allow oil, grease, detergent or water to come in contact with the spiral cable.
 - Do not cause impact to the spiral cable by dropping etc. Replace the spiral cable if it has been dropped or sustained an impact.
 - With the steering linkage disconnected, the cable may snap by turning the steering wheel beyond the limited number of turns. The spiral cable can be turned counterclockwise about 2.5 turns from the neutral position.
1. Disconnect the negative and positive battery cables, then wait at least 3 minutes.
 2. Remove the steering wheel. Refer to [ST-13, "Removal and Installation"](#).
 3. Remove the column cover. Refer to [IP-11, "Removal and Installation"](#).
 4. Disconnect the harness connectors (2) from spiral cable (1).

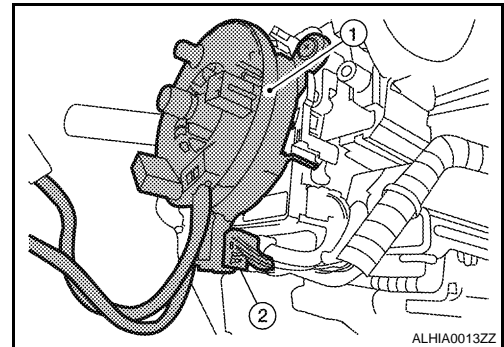

5. Rotate the spiral cable slightly so the locating pin (2) is positioned at the top.
6. Remove the screws (A), then remove spiral cable from the steering column.

CAUTION:

Do not turn the spiral cable quickly or beyond the limit number of turns (approximately 2.5 turns from the neutral position), this may cause the cable to snap.

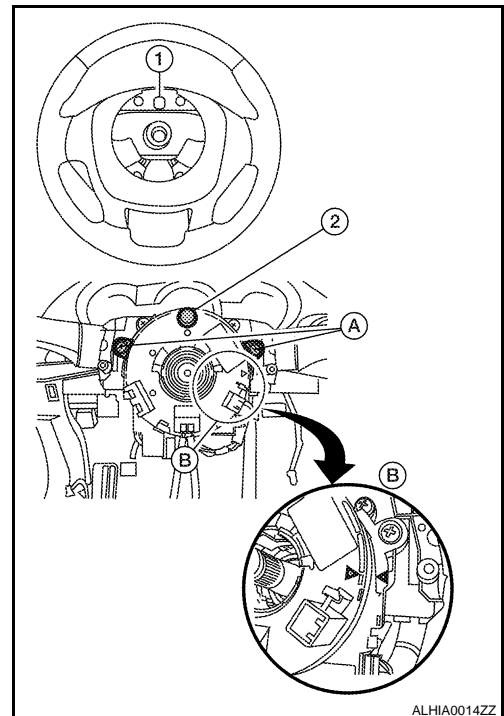

INSTALLATION

1. Set the spiral cable neutral position.
 1. Slowly turn the spiral cable clockwise to the end position.

SPIRAL CABLE

< ON-VEHICLE REPAIR >

2. Next, turn it counterclockwise (about 2.5 turns) then stop turning at the point when the alignment arrows (B) are directly across from each other. A
3. Rotate the spiral cable slightly so the locating pin (2) is positioned at the top. B

NOTE:

A service part is installed in the neutral position with a stopper clip in place and should not be adjusted after the stopper clip is removed. B

2. Install the spiral cable in the reverse order of removal.
3. Align the locating hole (1) at the top of the steering wheel with the locating pin of spiral cable during installation. C

CAUTION:

- The spiral cable may snap by steering operation if the cable is installed in an improper position. D
- Do not turn the spiral cable quickly or beyond the limit number of turns. (This can cause the cable to snap.) E
- After the work is completed, make sure no system malfunction is detected by air bag warning lamp.
- In case a malfunction is detected by the air bag warning lamp, reset with the self-diagnosis function and delete the memory with CONSULT-III. E
- If a malfunction is still detected after the above operation, perform self-diagnosis to repair malfunctions. Refer to [SRC-12, "SRS Operation Check"](#). F

G

SRS

I

J

K

L

M

N

O

P

FRONT PASSENGER AIR BAG MODULE

< ON-VEHICLE REPAIR >

FRONT PASSENGER AIR BAG MODULE

Removal and Installation

INFOID:00000000992982

REMOVAL

CAUTION:

- Before servicing, turn ignition switch OFF, disconnect both battery terminal and wait at least 3 minutes.
- Do not use air tools or electric tools for servicing.
- Always work from the side of air bag module. Do not work from the front of it.
- Always place air bag module with pad side facing upward.
- Do not use old bolts after removal; replace with new bolts.
- Do not cause impact to the air bag module by dropping etc. Replace the air bag module if it has been dropped or sustained an impact.

1. Disconnect the negative and positive battery cables, then wait at least 3 minutes.
2. Remove the glove box assembly. [IP-11, "Removal and Installation"](#).
3. Disconnect both front passenger air bag module connectors (1).

⇐ Vehicle front.

NOTE:

The figure shows installed condition of the front passenger air bag module. (Under view of the module installed without glove box in place.)

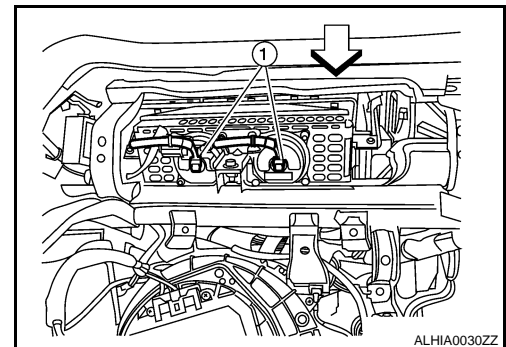

4. Remove front passenger air bag module bolt (A).
5. Remove the remaining instrument panel from the vehicle. Refer to [IP-11, "Removal and Installation"](#).

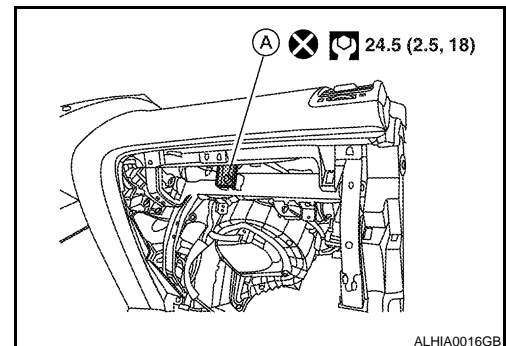

6. Remove the front passenger air bag module screws (A).
⇐ Vehicle front.
7. Rotate the front passenger air bag module and release the rear side hooks (1) from the instrument panel.
8. Remove the front passenger air bag module from the instrument panel.

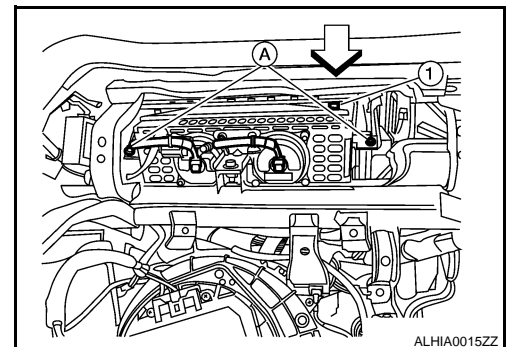

INSTALLATION - ORIGINAL PASSENGER AIR BAG MODULE

Installation is in the reverse order of removal.

CAUTION:

- Be careful not to damage the harness while installing.
- After the work is completed, make sure no system malfunction is detected by air bag warning lamp.
- In case a malfunction is detected by the air bag warning lamp, reset with the self-diagnosis function and delete the memory by CONSULT-III.

FRONT PASSENGER AIR BAG MODULE

< ON-VEHICLE REPAIR >

- If a malfunction is still detected after the above operation, perform self-diagnosis to repair malfunctions. Refer to [SRC-12, "SRS Operation Check"](#).

INSTALLATION - SERVICE REPLACEMENT PASSENGER AIR BAG MODULE

1. Install front passenger air bag module to the instrument panel assembly.
2. Install the instrument panel assembly. Refer to [IP-11, "Removal and Installation"](#).
3. Connect the front passenger air bag module harness connector to yellow 4-pin service replacement connector and fasten to mounting bracket.

Wiring Harness Modification

The front passenger air bag module originally installed in the vehicle uses direct-connect style harness connectors. Service replacement passenger air bag modules use tab-locking style harness connectors. If the front passenger air bag module is replaced, or if the direct-connect harness connectors are damaged, the vehicle wiring harness must be modified to allow connection of the service replacement front passenger air bag module.

NOTE:

The wiring harness modification is to be performed only if the vehicle is equipped with the original front passenger air bag module which uses direct-connect harness connectors. If the front passenger air bag module is to be replaced in a vehicle that has already had the service replacement front passenger air bag module installed, the wiring harness modification is not required.

1. Locate the yellow and orange direct-connect front passenger air bag module harness connectors.
2. Use wire cutters to cut back both previously used direct-connect front passenger air bag module harness connectors from the vehicle wiring harness approximately 50 mm (1.9 in) from the connectors.
3. Remove approximately 150 mm (5.9 in) of the vehicle harness covering from the cut end.
4. Slide a piece of dual-wall heat shrink tubing (provided in the passenger air bag module service kit) onto each wire of the previously used vehicle wiring harness.

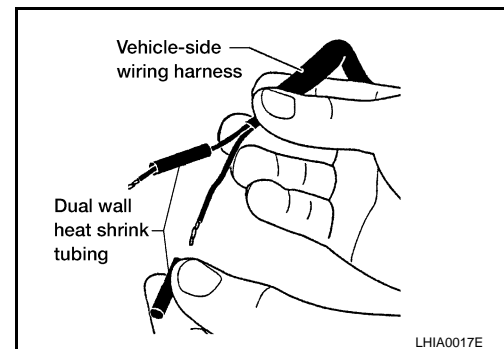

5. Fold each wire back and insert into the end of the heat shrink tubing so that the end of the wire is approximately centered in the heat shrink tubing.
6. Use a heat gun to shrink the heat shrink tubing and seal the wire.
7. Use electrical tape to secure the modified circuits to the outside of the wiring harness.

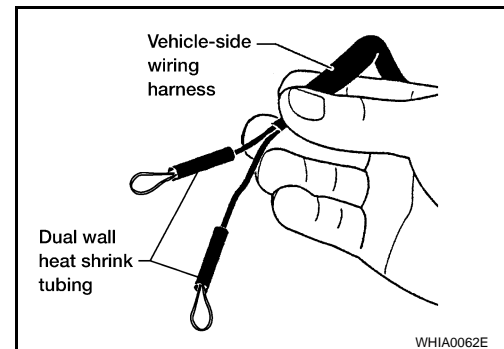

8. Locate the front passenger air bag module service replacement connector that is taped back to the main harness. Unwrap the tape to access the yellow service replacement connector and remove the dust cover from the connector.
 9. Connect service connector to front passenger air bag module.
 10. Clip to service connector clipping point.
- After the work is completed, perform self-diagnosis to check that no malfunction is detected. Refer to [SRC-12, "SRS Operation Check"](#).

A
B
C
D
E
F
G
I
J
K
L
M
N
O
P

SRS

SIDE CURTAIN AIR BAG MODULE

< ON-VEHICLE REPAIR >

SIDE CURTAIN AIR BAG MODULE

Exploded View

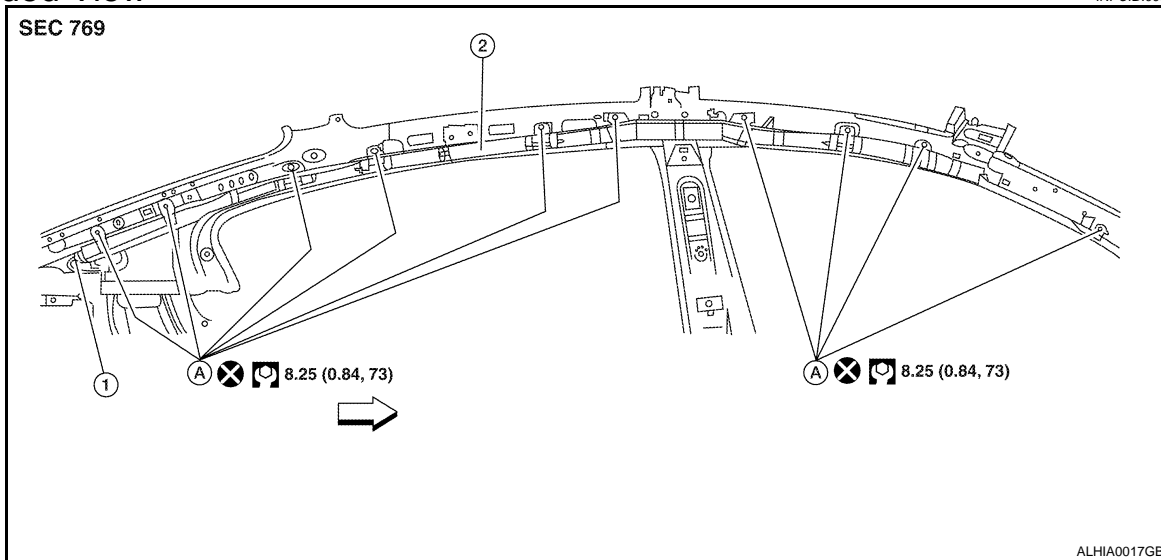

1. Side curtain air bag module connector 2. Side curtain air bag module A. Side curtain air bag module bolt

← Vehicle front

Removal and Installation

INFOID:000000000992984

REMOVAL

CAUTION:

- Before servicing, turn ignition switch OFF, disconnect both battery terminal and wait at least 3 minutes.
- Do not use air tools or electric tools for servicing.
- Always work from the side of air bag module. Do not work from the front of it.
- Always place the curtain air bag module with air bag deployment side facing upward.
- Do not cause impact to the air bag module by dropping etc. Replace the air bag module if it has been dropped or sustained an impact.

1. Disconnect the negative and positive battery cables, then wait at least 3 minutes.
2. Remove the headlining. Refer to [INT-19, "Removal and Installation"](#).
3. Disconnect the side curtain air bag module connector.
 - For installing/removing direct-connect SRS connectors, refer to [SRC-8, "Direct-connect SRS Component Connectors"](#).
4. Remove the bolts, then remove side curtain air bag module.

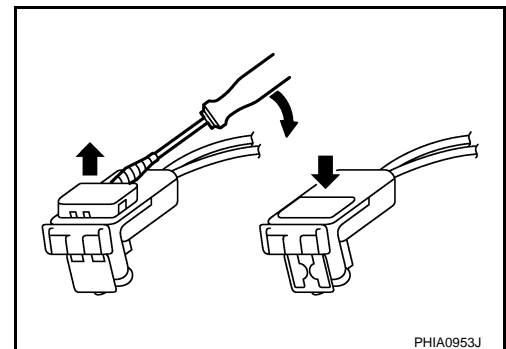

INSTALLATION

Installation is in the reverse order of removal.

CAUTION:

- Be careful not to damage the air bag harness.
- After the work is completed, make sure no system malfunction is detected by air bag warning lamp.
- In case a malfunction is detected by the air bag warning lamp, reset by the self-diagnosis function and delete the memory by CONSULT-III.

SIDE CURTAIN AIR BAG MODULE

< ON-VEHICLE REPAIR >

- If a malfunction is still detected after the above operation, perform self-diagnosis to repair malfunctions. Refer to [SRC-12, "SRS Operation Check"](#).
- Make sure the side curtain air bag module is not twisted at any point along the vehicle when installed.

A

B

C

D

E

F

G

SRS

I

J

K

L

M

N

O

P

CRASH ZONE SENSOR

< ON-VEHICLE REPAIR >

CRASH ZONE SENSOR

Exploded View

INFOID:000000000992985

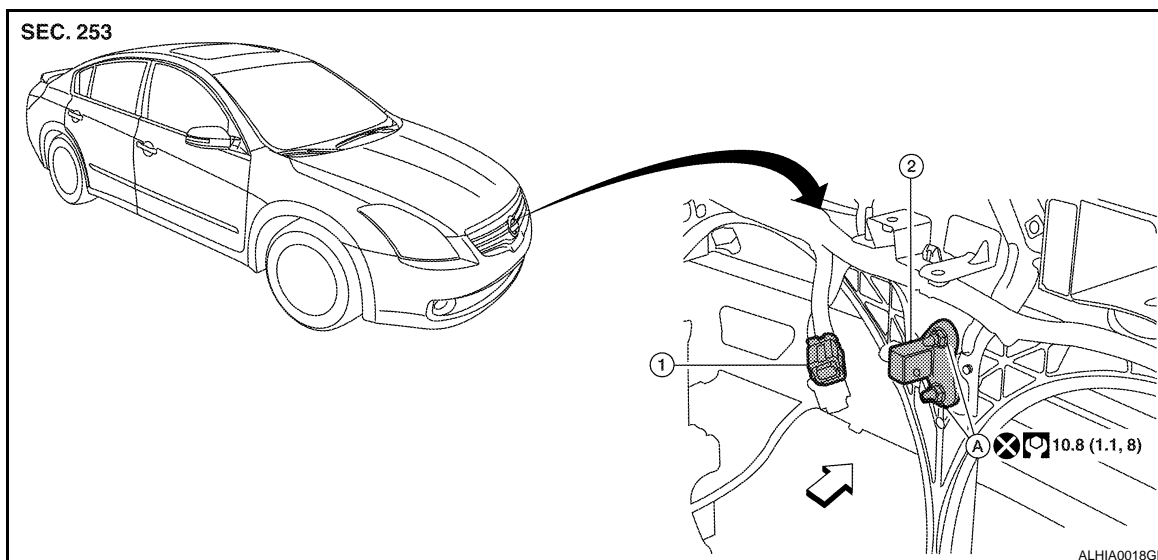

1. Crash zone sensor harness connector
2. Crash zone sensor
A. Crash zone sensor nuts

↶ Vehicle front

Removal and Installation

INFOID:000000000992986

REMOVAL

CAUTION:

- Before servicing, turn ignition switch OFF, disconnect both battery terminal and wait at least 3 minutes.
- Do not use air tools or electric tools for servicing.
- Do not use old fixing nuts after removal; replace with new nuts.
- Do not cause impact to the crash zone sensor by dropping etc. Replace the crash zone sensor if it has been dropped or sustained an impact.
- Replace the crash zone sensor of deployed SRS driver air bag and deployed SRS front passenger air bag.

1. Disconnect the negative and positive battery cables, then wait at least 3 minutes.
2. Remove the cover and the air duct.
3. Remove the center clamp screw for upper radiator hose and position aside.
4. Disconnect the crash zone sensor harness connector.
5. Remove the nuts, then remove crash zone sensor.

INSTALLATION

Installation is in the reverse order of removal.

CAUTION:

- Be careful not to damage the crash zone sensor harness.
- After the work is completed, make sure no system malfunction is detected by air bag warning lamp.
- In case a malfunction is detected by the air bag warning lamp, reset by the self-diagnosis function and delete the memory by CONSULT-III.
- If a malfunction is still detected after the above operation, perform self-diagnosis to repair malfunctions. Refer to [SRC-12, "SRS Operation Check"](#).

SIDE AIR BAG (SATELLITE) SENSOR

< ON-VEHICLE REPAIR >

SIDE AIR BAG (SATELLITE) SENSOR

Exploded View

INFOID:000000000992987

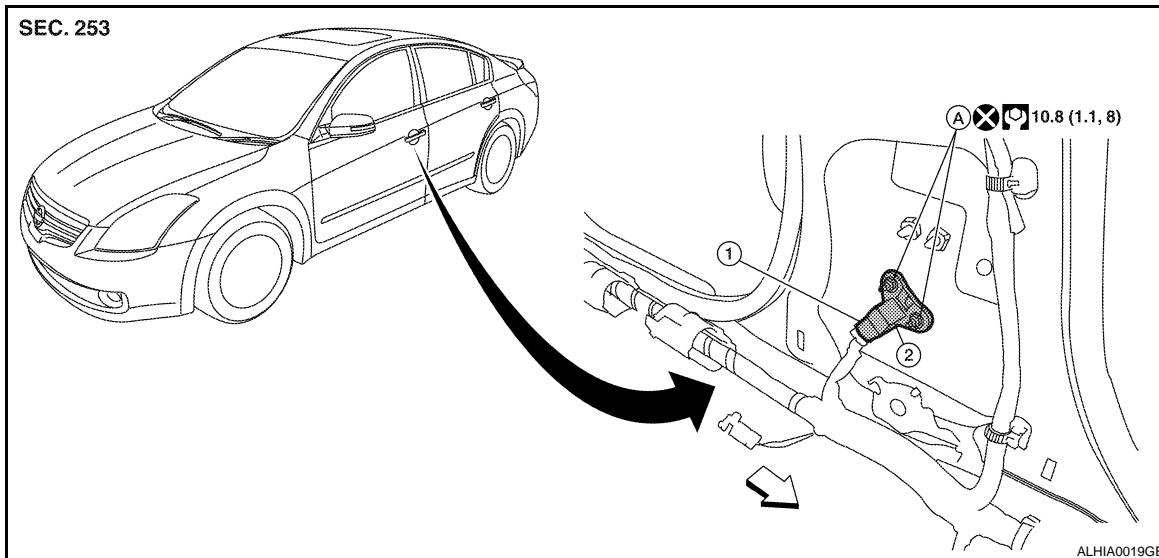

1. Side air bag (satellite) sensor harness connector 2. Side air bag (satellite) sensor A. Side air bag (satellite) sensor nuts

← Vehicle front

SRS

Removal and Installation

INFOID:000000000992988

REMOVAL

CAUTION:

- Before servicing, turn ignition switch OFF, disconnect both battery terminal and wait at least 3 minutes.
- Do not use air tools or electric tools for servicing.
- Do not use old fixing nuts after removal; replace with new nuts.
- Do not cause impact to the side air bag (satellite) sensor by dropping etc. Replace the side air bag (satellite) sensor if it has been dropped or sustained an impact.
- Replace the satellite sensor of deployed SRS front side air bag and deployed SRS side curtain air bag.

1. Disconnect the negative and positive battery cables, then wait at least 3 minutes.
2. Remove the front seat belt retractor. Refer to [SB-6, "SEAT BELT RETRACTOR : Removal and Installation"](#).
3. Disconnect the side air bag (satellite) sensor harness connector.
4. Remove the nuts, then remove side air bag (satellite) sensor.

INSTALLATION

Installation is in the reverse order of removal.

CAUTION:

- Be careful not to damage the satellite sensor harness.
- After the work is completed, make sure no system malfunction is detected by air bag warning lamp.
- In case a malfunction is detected by the air bag warning lamp, reset by the self-diagnosis function and delete the memory by CONSULT-III.
- If a malfunction is still detected after the above operation, perform self-diagnosis to repair malfunctions. Refer to [SRC-12, "SRS Operation Check"](#).

DIAGNOSIS SENSOR UNIT

< ON-VEHICLE REPAIR >

DIAGNOSIS SENSOR UNIT

Exploded View

INFOID:000000000992989

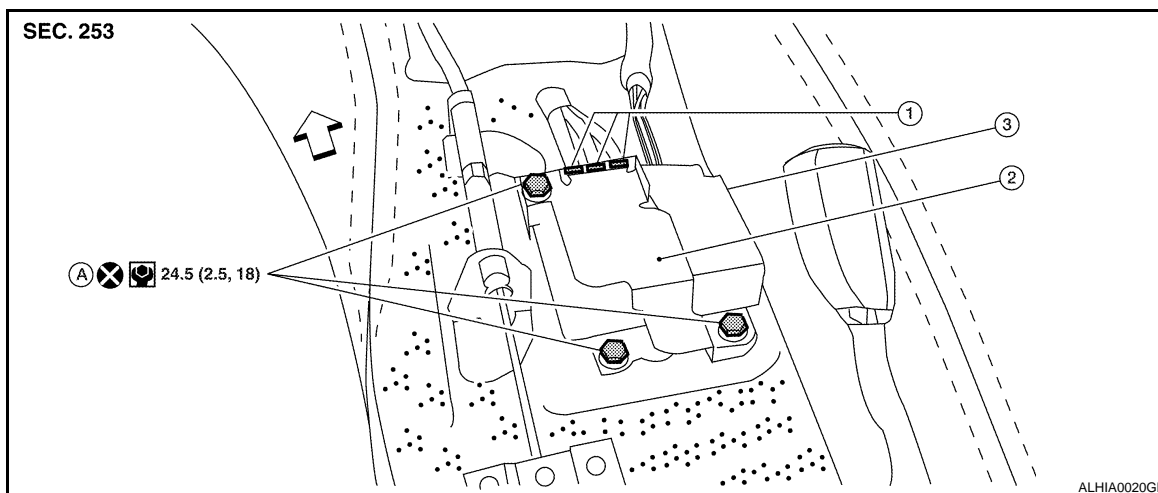

1. Diagnosis sensor unit harness connector 2. Diagnosis sensor unit shield 3. Diagnosis sensor unit
- A. Diagnosis sensor unit bolts ← Vehicle front

Removal and Installation

INFOID:000000000992990

REMOVAL

CAUTION:

- Before servicing, turn ignition switch OFF, disconnect both battery terminal and wait at least 3 minutes.
- Before disconnecting the air bag sensor unit harness connector, be sure to disconnect the harness connector of each air bag module and pre-tensioner seat belt to prevent air bag deployment by static electricity.
- Do not use air tools or electric tools for servicing.
- Do not use old bolts after removal; replace with new bolts.
- Do not cause an impact to the diagnosis sensor unit by dropping etc. Replace the diagnosis sensor unit if it has been dropped or sustained an impact.
- Replace the diagnosis sensor unit of deployed SRS air bag and deployed SRS front seat belt pre-tensioner.

1. Disconnect the negative and positive battery cables, then wait at least 3 minutes.
2. Disconnect connector of each air bag module and seat belt pre-tensioner. Refer to [SRS-4. "Removal and Installation"](#), [SRS-8. "Removal and Installation"](#), [SRS-10. "Removal and Installation"](#), [SE-19. "Removal and Installation"](#), [SB-6. "SEAT BELT RETRACTOR : Removal and Installation"](#).
3. Remove the center console. Refer to [IP-16. "Disassembly and Assembly"](#).
4. Disconnect the diagnosis sensor unit harness connectors.
5. Remove the bolts, then remove the diagnosis sensor unit.

INSTALLATION

Installation is in the reverse order of removal.

CAUTION:

- Be careful not to damage the diagnosis sensor unit harness.
- After the work is completed, make sure no system malfunction is detected by air bag warning lamp.
- In case a malfunction is detected by the air bag warning lamp, reset by the self-diagnosis function and delete the memory by CONSULT-III.
- If a malfunction is still detected after the above operation, perform self-diagnosis to repair malfunctions. Refer to [SRC-12. "SRS Operation Check"](#).

DIAGNOSIS SENSOR UNIT

< ON-VEHICLE REPAIR >

ECU DISCRIMINATED NO.

After replacing the diagnosis sensor unit, confirm that the diagnosis sensor unit identification is correct for the vehicle as equipped. Refer to [SRC-14, "CONSULT-III Function \(AIR BAG\)"](#).

A

B

C

D

E

F

G

SRS

I

J

K

L

M

N

O

P

OCCUPANT CLASSIFICATION SYSTEM CONTROL UNIT

< ON-VEHICLE REPAIR >

OCCUPANT CLASSIFICATION SYSTEM CONTROL UNIT

Removal and Installation

INFOID:000000000992991

The occupant classification system control unit, occupant classification system sensor, and sensor mat are an integral part of the front passenger seat cushion and are replaced as an assembly. Refer to [SE-25. "PASSENGER SIDE : Disassembly"](#).

COLLISION DIAGNOSIS

< ON-VEHICLE REPAIR >

COLLISION DIAGNOSIS

For Frontal Collision

INFOID:00000000992992

Check the SRS components using the following table.

- After the work is completed, perform self-diagnosis to check that no malfunction is detected. Refer to [SRC-12. "SRS Operation Check"](#).

SRS INSPECTION (FOR FRONTAL COLLISION)

Part	SRS is activated	SRS is NOT activated
Driver air bag module	If the driver air bag has deployed: REPLACE Install with new fasteners.	If the driver air bag has NOT been activated: 1. Remove driver air bag module. Check harness cover and connectors for damage, terminals for deformities, and harness for binding. 2. Install driver air bag module into the steering wheel to check fit and alignment with the wheel. 3. If no damage is found, reinstall with new fasteners. 4. If damaged—REPLACE. Install driver air bag modules with new fasteners.
Front passenger air bag module	If the front passenger air bag has deployed: REPLACE Install with new fasteners.	If the front passenger air bag has NOT been activated: 1. Remove front passenger air bag module. Check harness cover and connectors for damage, terminals for deformities, and harness for binding. 2. Install front passenger air bag module into the instrument panel to check fit with the instrument panel. 3. If no damage is found, reinstall with new fasteners. 4. If damaged—REPLACE. Install front passenger air bag modules with new fasteners.
Crash zone sensor	If any of the front air bags or seat belt pre-tensioners* have been activated: REPLACE the crash zone sensor and bracket with new fasteners. *: Confirm seat belt pre-tensioner activation using CONSULT-III only.	If the front air bags or seat belt pre-tensioners have NOT been activated: 1. Remove the crash zone sensor. Check harness connectors for damage, terminals for deformities, and harness for binding. 2. Check for visible signs of damage (dents, cracks, deformation) of the crash zone sensor and bracket. 3. Install the crash zone sensor to check fit. 4. If no damage is found, reinstall with new fasteners. 5. If damaged—REPLACE the crash zone sensor and bracket with new fasteners.
Seat belt pre-tensioner assemblies (All applicable locations: buckle, reel, lap outer)	If either the driver or passenger seat belt pre-tensioner* has been activated: REPLACE all seat belt pre-tensioner assemblies with new fasteners. *: Confirm seat belt pre-tensioner activation using CONSULT-III only.	If the pre-tensioners have NOT been activated: 1. Remove seat belt pre-tensioners. Check harness cover and connectors for damage, terminals for deformities, and harness for binding. 2. Check belts for damage and anchors for loose mounting. 3. Check retractor for smooth operation. 4. Check seat belt adjuster for damage. 5. Check for deformities of the center pillar inner. 6. If the center pillar inner has no damage, REPLACE the seat belt pre-tensioner assembly. 7. If no damage is found, reinstall seat belt pre-tensioner assembly. 8. If damaged—REPLACE. Install the seat belt pre-tensioners with new fasteners.
Diagnosis sensor unit	If any of the SRS components have been activated: REPLACE the diagnosis sensor unit. Install with new fasteners.	If none of the SRS components have been activated: 1. Check case for dents, cracks or deformities. 2. Check connectors for damage, and terminals for deformities. 3. If no damage is found, reinstall with new fasteners. 4. If damaged—REPLACE. Install diagnosis sensor unit with new fasteners.

A

B

C

D

E

F

G

SRS

I

J

K

L

M

N

O

P

COLLISION DIAGNOSIS

< ON-VEHICLE REPAIR >

Part	SRS is activated	SRS is NOT activated
Steering wheel	<ol style="list-style-type: none"> 1. Visually check steering wheel for deformities. 2. Check harness (built into steering wheel) and connectors for damage, and terminals for deformities. 3. Install driver air bag module into the steering wheel to check fit and alignment with the wheel. 4. Check steering wheel for excessive free play. 5. If no damage is found, reinstall. 6. If damaged—REPLACE. 	
Spiral cable	If the driver front air bag has deployed: REPLACE the spiral cable.	If the driver front air bag has not deployed: <ol style="list-style-type: none"> 1. Visually check spiral cable and combination switch for damage. 2. Check connectors and protective tape for damage. 3. Check steering wheel for noise, binding or heavy operation. 4. If no damage is found, reinstall. 5. If damaged—REPLACE.
Occupant classification system (Passenger seat)	<ol style="list-style-type: none"> 1. Remove passenger seat. 2. Check control unit case for dents, cracks or deformities. 3. Check connectors and pressure sensor tube for damage, and terminals for deformities. 4. Check seat frame and cushion pan for dents or deformities. 5. If no damage is found, reinstall seat with new fasteners. 6. If damaged — REPLACE seat cushion assembly with new fasteners. 	
Harness and connectors	<ol style="list-style-type: none"> 1. Check connectors for poor connection, damage, and terminals for deformities. 2. Check harness for binding, chafing, cuts, or deformities. 3. If no damage is found, reinstall the harness and connectors. 4. If damaged—REPLACE the damaged harness. Do not attempt to repair, splice or modify any SRS harness. 	
Instrument panel	If the passenger front air bag has deployed: REPLACE the instrument panel assembly.	If the passenger front air bag has NOT deployed: <ol style="list-style-type: none"> 1. Visually check instrument panel for damage. 2. If no damage is found, reinstall the instrument panel. 3. If damaged—REPLACE the instrument panel.

For Side and Rollover Collision

INFOID:000000000992993

Check the SRS components using the following table.

- After the work is completed, perform self-diagnosis to check that no malfunction is detected. Refer to [SRC-12. "SRS Operation Check"](#).

WHEN SRS IS ACTIVATED IN THE SIDE OR ROLLOVER COLLISION

1. Replace the following components:
 - Front seat back assembly (on the side on which side air bag is activated)
 - Diagnosis sensor unit
 - (LH or RH) side air bag (satellite) sensor (on the side on which side air bag is activated)
2. Check the SRS components and the related parts using the following table.
 - Replace any SRS components and the related parts showing visible signs of damage (dents, cracks, deformation).
3. Conduct self-diagnosis using CONSULT-III and "AIR BAG" warning lamp. Refer to [SRC-12. "SRS Operation Check"](#) for details. Make sure entire SRS operates properly.

WHEN SRS IS NOT ACTIVATED IN THE SIDE OR ROLLOVER COLLISION

1. Check the SRS components and the related parts using the following table.
 - If the front seat back assembly is damaged, the front seat back assembly must be replaced.
2. Conduct self-diagnosis using CONSULT-III and "AIR BAG" warning lamp. Refer to [SRC-12. "SRS Operation Check"](#) for details. Make sure entire SRS operates properly.

SRS INSPECTION (FOR SIDE AND ROLLOVER COLLISION)

COLLISION DIAGNOSIS

< ON-VEHICLE REPAIR >

Part	SRS is activated	SRS is NOT activated
LH side curtain air bag module	If the LH side curtain air bag has deployed: REPLACE the LH side curtain air bag module. (Repair the center pillar inner, etc. before installing new one if damaged.)	If the LH side curtain air bag has NOT deployed: <ol style="list-style-type: none"> 1. Check for visible signs of damage (dents, tears, deformation) of the center pillar on the collision side. 2. If damaged—Remove the LH side curtain air bag module. 3. Check for visible signs of damaged (tears etc.) of the LH side curtain air bag module. 4. Check harness and connectors for damage, and terminals for deformities. 5. If no damage is found, reinstall the LH side curtain air bag module with new fasteners. 6. If damaged—REPLACE the LH side curtain air bag module with new fasteners.
RH side curtain air bag module	If the RH side curtain air bag has deployed: REPLACE the RH side curtain air bag module. (Repair the center pillar inner, etc. before installing new one if damaged.)	If the RH side curtain air bag has NOT deployed: <ol style="list-style-type: none"> 1. Check for visible signs of damage (dents, tears, deformation) of the center pillar on the collision side. 2. If damaged—Remove the RH side curtain air bag module. 3. Check for visible signs of damaged (tears etc.) of the RH side curtain air bag module. 4. Check harness and connectors for damage, and terminals for deformities. 5. If no damage is found, reinstall the RH side curtain air bag module with new fasteners. 6. If damaged—REPLACE the RH side curtain air bag module with new fasteners.
Front LH side air bag module	If the front LH side air bag has deployed: REPLACE front LH seatback assembly.	If the front LH side air bag has NOT deployed: <ol style="list-style-type: none"> 1. Check for visible signs of damage (dents, tears, deformation) of the seat back on the collision side. 2. Check harness and connectors for damage, and terminals for deformities. 3. If damaged—REPLACE the front LH seatback assembly.
Front RH side air bag module	If the front RH side air bag has deployed: REPLACE front RH seatback assembly.	If the front RH side air bag has NOT deployed: <ol style="list-style-type: none"> 1. Check for visible signs of damage (dents, tears, deformation) of the seat back on the collision side. 2. Check harness and connectors for damage, and terminals for deformities. 3. If damaged—REPLACE the front RH seatback assembly.
(LH or RH) side air bag (satellite) sensor	If any of the SRS components have deployed: REPLACE the side air bag (satellite) sensor on the collision side with new fasteners. (Repair the center pillar inner, etc. before installing new one if damaged.)	If none of the SRS components have been activated: <ol style="list-style-type: none"> 1. Remove the side air bag (satellite) sensor on the collision side. Check harness connectors for damage, terminals for deformities, and harness for binding. 2. Check for visible signs of damage (dents, cracks, deformation) of the side air bag (satellite) sensor. 3. Install the side air bag (satellite) sensor to check fit. 4. If no damage is found, reinstall the side air bag (satellite) sensor with new fasteners. 5. If damaged—REPLACE the side air bag (satellite) sensor with new fasteners.
Diagnosis sensor unit	If any of the SRS components have deployed: REPLACE the diagnosis sensor unit with new fasteners.	If none of the SRS components have been activated: <ol style="list-style-type: none"> 1. Check case and bracket for dents, cracks or deformities. 2. Check connectors for damage, and terminals for deformities. 3. If no damage is found, reinstall the diagnosis sensor unit with new fasteners. 4. If damaged—REPLACE the diagnosis sensor unit with new fasteners.
Seat belt pre-tensioner assemblies (All applicable locations: buckle, reel, lap outer)	If either the driver or passenger seat belt pre-tensioner* has been activated: REPLACE all seat belt pre-tensioner assemblies with new fasteners. *: Confirm seat belt pre-tensioner activation using CONSULT-III only.	If the pre-tensioners have NOT been activated: <ol style="list-style-type: none"> 1. Remove seat belt pre-tensioners. Check harness cover and connectors for damage, terminals for deformities, and harness for binding. 2. Check belts for damage and anchors for loose mounting. 3. Check retractor for smooth operation. 4. Check seat belt adjuster for damage. 5. Check for deformities of the center pillar inner. 6. If the center pillar inner has no damage, REPLACE the seat belt pre-tensioner assembly. 7. If no damage is found, reinstall seat belt pre-tensioner assembly. 8. If damaged—REPLACE. Install the seat belt pre-tensioners with new fasteners.

A

B

C

D

E

F

G

SRS

I

J

K

L

M

N

O

P

COLLISION DIAGNOSIS

< ON-VEHICLE REPAIR >

Part	SRS is activated	SRS is NOT activated
Seat (with front side air bag)	If either the front LH or front RH side air bag modules has been deployed: REPLACE front seat-back assembly on the deployed side.	If the front LH or front RH side air bag modules have NOT deployed: <ol style="list-style-type: none"> 1. Visually check the seat on the collision side. 2. Remove the seat on the collision side and check the following for damage and deformities. <ul style="list-style-type: none"> - Harness, connectors and terminals - Frame and recliner (for front and rear seat), and also adjuster and slides (for front seat) 3. If no damage is found, reinstall the seat. 4. If damaged—REPLACE the damaged seat parts using new fasteners. If the front seat back is damaged, the front seat back assembly must be replaced.
Center inner pillar	<ol style="list-style-type: none"> 1. Check the center inner pillar on the collision side for damage (dents, cracks, deformation). 2. If damaged—REPAIR the center inner pillar. 	
Trim/headlining	<ol style="list-style-type: none"> 1. Check for visible signs of damage (dents, cracks, deformation) of the interior trim on the collision side. 2. If damaged—REPLACE the damaged trim parts. 	