

A
FL
C
D
E
F
G
H
I
J
K
L
M
N
O
P

SECTION FL
FUEL SYSTEM

CONTENTS

PRECAUTION	2	ON-VEHICLE REPAIR	7
PRECAUTIONS	2	FUEL LEVEL SENSOR UNIT, FUEL FILTER AND FUEL PUMP ASSEMBLY	7
Precaution for Supplemental Restraint System (SRS) "AIR BAG" and "SEAT BELT PRE-TENSIONER"	2	Exploded View	7
PREPARATION	3	Removal and Installation	7
PREPARATION	3	Inspection	10
Special Service Tool	3	FUEL TANK	11
Commercial Service Tool	3	Exploded View	11
ON-VEHICLE MAINTENANCE	4	Removal and Installation	11
FUEL SYSTEM	4	Inspection	13
Inspection	4	SERVICE DATA AND SPECIFICATIONS (SDS)	15
Quick Connector	4	SERVICE DATA AND SPECIFICATIONS (SDS)	15
FUEL SYSTEM	5	Fuel Tank	15
Checking Fuel Line	5		
General Precaution	5		

PRECAUTIONS

< PRECAUTION >

PRECAUTION

PRECAUTIONS

Precaution for Supplemental Restraint System (SRS) "AIR BAG" and "SEAT BELT PRE-TENSIONER"

INFOID:000000000990416

The Supplemental Restraint System such as "AIR BAG" and "SEAT BELT PRE-TENSIONER", used along with a front seat belt, helps to reduce the risk or severity of injury to the driver and front passenger for certain types of collision. This system includes seat belt switch inputs and dual stage front air bag modules. The SRS system uses the seat belt switches to determine the front air bag deployment, and may only deploy one front air bag, depending on the severity of a collision and whether the front occupants are belted or unbelted. Information necessary to service the system safely is included in the SRS and SB section of this Service Manual.

WARNING:

- To avoid rendering the SRS inoperative, which could increase the risk of personal injury or death in the event of a collision which would result in air bag inflation, all maintenance must be performed by an authorized NISSAN/INFINITI dealer.
- Improper maintenance, including incorrect removal and installation of the SRS, can lead to personal injury caused by unintentional activation of the system. For removal of Spiral Cable and Air Bag Module, see the SRS section.
- Do not use electrical test equipment on any circuit related to the SRS unless instructed to in this Service Manual. SRS wiring harnesses can be identified by yellow and/or orange harnesses or harness connectors.

PREPARATION

< PREPARATION >

PREPARATION

PREPARATION

Special Service Tool

INFOID:000000000990417

A

FL

The actual shape of the Kent-Moore tools may differ from those tools illustrated here.

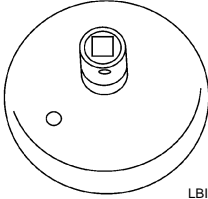
Tool number (Kent-Moore No.) Tool name	Description
KV991J0090 (J-46214) Fuel tank lock ring wrench  LBIA0353E	Removing and installing fuel tank lock ring

C

D

E

F

Commercial Service Tool

INFOID:000000000990418

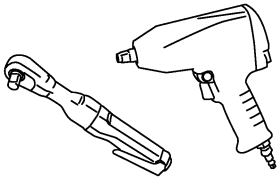
Tool name	Description
Power tool  PBIC0190E	Loosening bolts and nuts

G

H

I

J

K

L

M

N

O

P

FUEL SYSTEM

< ON-VEHICLE MAINTENANCE >

ON-VEHICLE MAINTENANCE

FUEL SYSTEM

Inspection

INFOID:000000000990419

Inspect fuel lines, fuel filler cap and fuel tank for improper attachment, leaks, cracks, damage, loose connections, chafing or deterioration.

If necessary, repair or replace damaged parts.

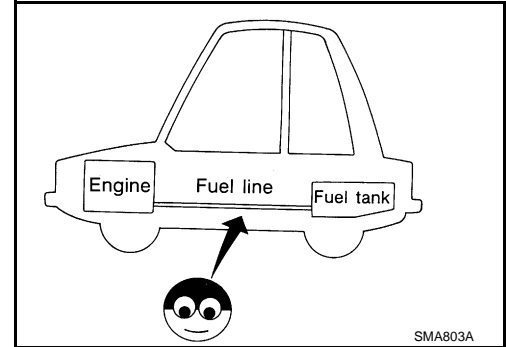

Quick Connector

INFOID:000000000990420

CAUTION:

- After connecting fuel tube quick connectors, make sure quick connectors are secure. Ensure that connector and resin tube do not contact any adjacent parts.

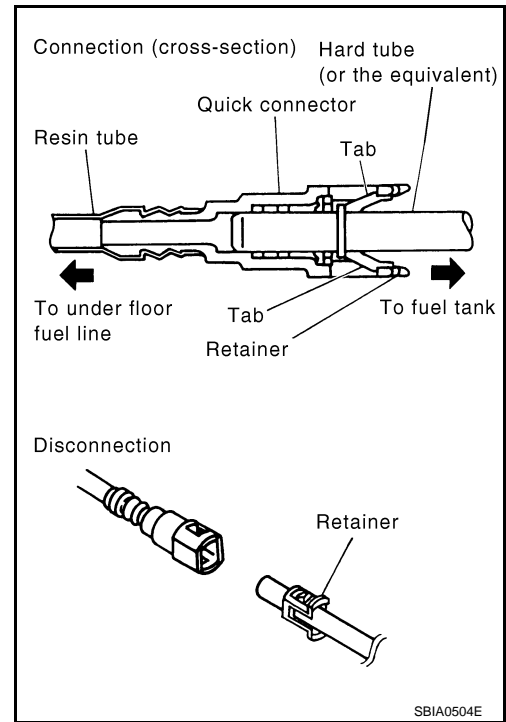

FUEL SYSTEM

< ON-VEHICLE MAINTENANCE >

FUEL SYSTEM

Checking Fuel Line

INFOID:000000000990421

Inspect fuel lines, filler cap and tank for improper attachment, leaks, cracks, damage, loose connections, chafing or deterioration. If necessary, repair or replace faulty parts as necessary.

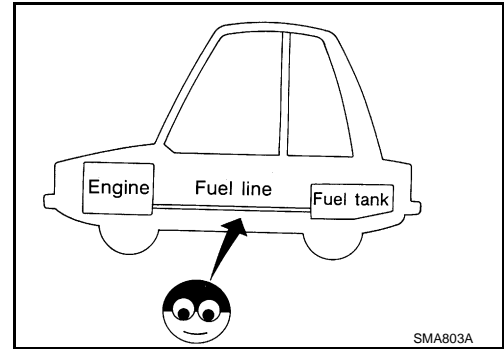

General Precaution

INFOID:000000000990422

WARNING:

When replacing fuel line parts, be sure to observe the following.

- Put a "CAUTION: FLAMMABLE" sign in the work area.
- Be sure to work in a well ventilated area and have a CO² fire extinguisher.
- Do not smoke while working on the fuel system. Keep open flames and sparks away from the work area.

CAUTION:

Before removing fuel line parts, carry out the following procedures:

- Put drained fuel in an explosion-proof container and put the lid on securely. Keep the container in safe area.
- Release fuel pressure from the fuel lines. Refer to [EC-1038, "Inspection"](#) (QR25DE), [EC-522, "Inspection"](#) (VQ35DE).
- Disconnect the battery ground cable.
- Always replace O-rings and clamps with new ones.
- Do not kink or twist tubes when they are being installed.
- Do not tighten hose clamps excessively to avoid damaging hoses.

Tighten high-pressure rubber hose clamp so that clamp end is 3 mm (0.12 in) from hose end.

Tightening torque specifications are the same for all rubber hose clamps.

Ensure that screw does not contact adjacent parts.

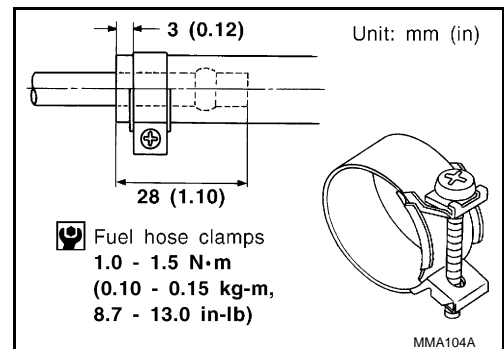

FUEL SYSTEM

< ON-VEHICLE MAINTENANCE >

- After connecting the fuel tube quick connectors, make sure the quick connectors are secure. Check that the connector and resin tube do not contact any adjacent parts.
- a) Apply fuel pressure to the fuel system by turning the ignition switch to ON (without starting the engine). Then check for fuel leaks at the fuel tube connections.
- b) Start the engine and rev the engine, then check for fuel leaks at the fuel tube connections.
- After installing the tubes, run the engine and check for fuel leaks at the connections.
- Use only a Genuine NISSAN fuel filler cap as a replacement. If an incorrect fuel filler cap is used, the MIL may come on.
- For servicing "Evaporative Emission System" parts, refer to [EC-1112, "System Description"](#) (QR25DE except California), [EC-595, "System Description"](#) (QR25DE for California), [EC-92, "System Description"](#) (VQ35DE).
- For servicing "On Board Refueling Vapor Recovery (ORVR)" parts, refer to [EC-1112, "System Description"](#) (QR25DE except California), [EC-973, "Description"](#) (QR25DE for California), [EC-448, "Description"](#) (VQ35DE).

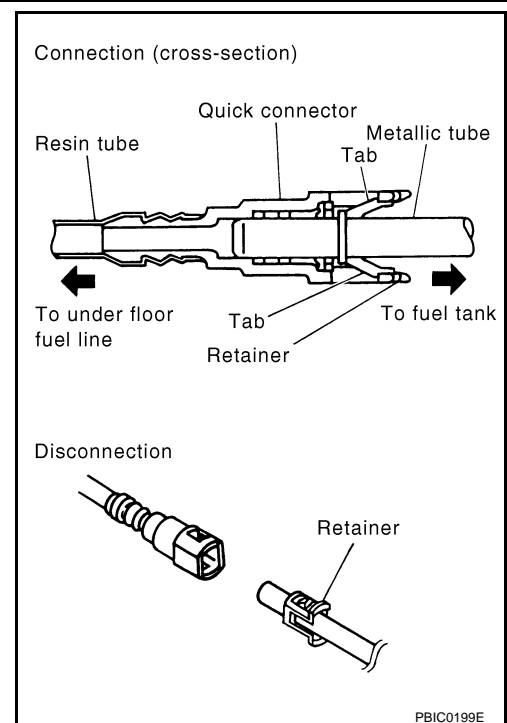

FUEL LEVEL SENSOR UNIT, FUEL FILTER AND FUEL PUMP ASSEMBLY

< ON-VEHICLE REPAIR >

ON-VEHICLE REPAIR

FUEL LEVEL SENSOR UNIT, FUEL FILTER AND FUEL PUMP ASSEMBLY

Exploded View

INFOID:000000000990423

A

FL

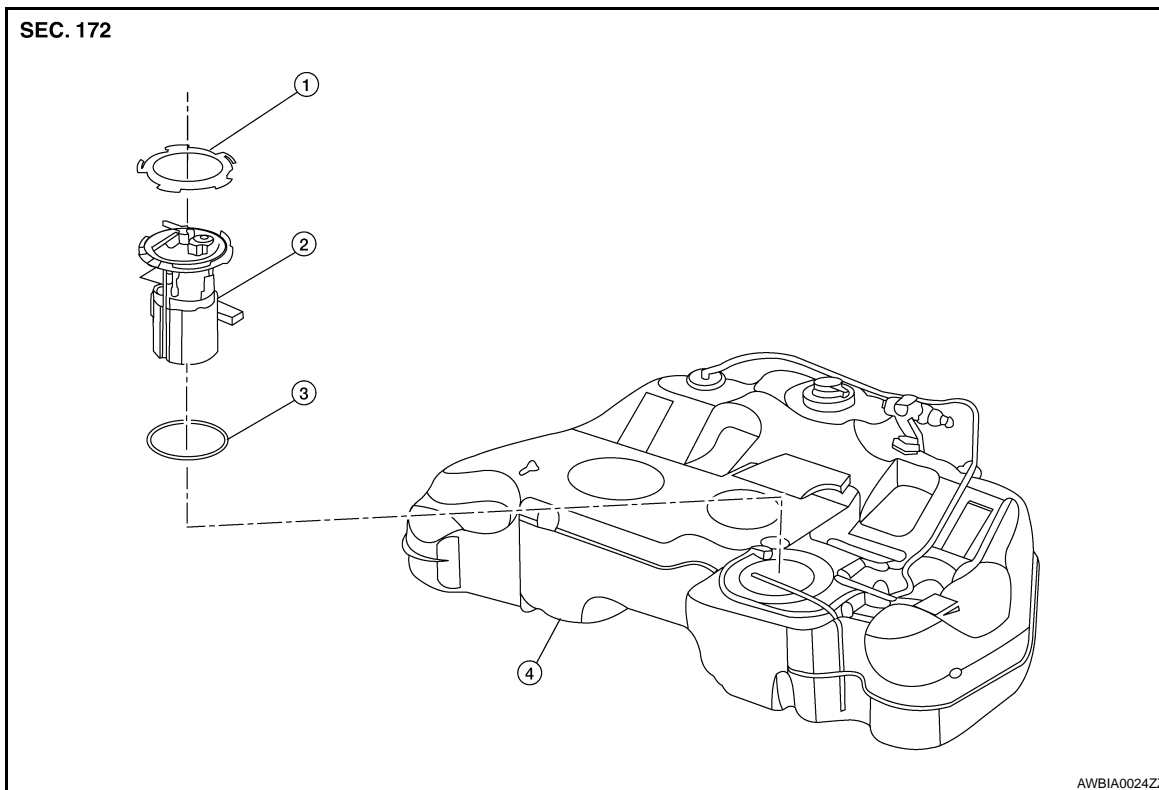

1. Lock ring
2. Fuel level sensor unit, fuel filter and fuel pump assembly
3. O-ring
4. Fuel Tank

Removal and Installation

INFOID:000000000990424

REMOVAL

WARNING:

Read "General Precautions" before working on the fuel system.

Refer to [GI-25, "General Precautions"](#).

1. Unscrew the fuel filler cap to release the pressure inside the fuel tank.
2. Release the fuel pressure from the fuel lines. Refer to [EC-1038, "Inspection"](#) (QR25DE), [EC-522, "Inspection"](#) (VQ35DE).
3. Disconnect the battery negative terminal.
4. Remove the rear seat bottom. Refer to [SE-21, "Removal and Installation"](#).

FUEL LEVEL SENSOR UNIT, FUEL FILTER AND FUEL PUMP ASSEMBLY

< ON-VEHICLE REPAIR >

- Turn the four retainers 90° in a clockwise direction and remove the fuel pump inspection hole cover.

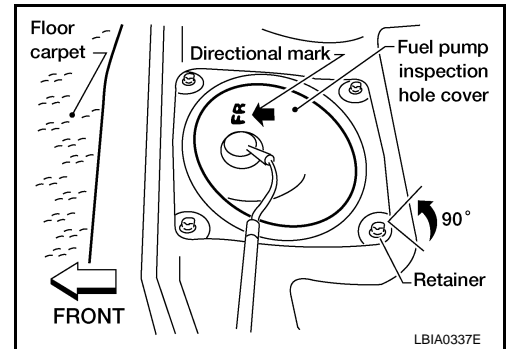

- Disconnect the fuel level sensor, fuel filter, and fuel pump assembly electrical connector, EVAP hose quick connector, and the fuel feed hose quick connector from the fuel level sensor unit, fuel filter, and fuel pump assembly.

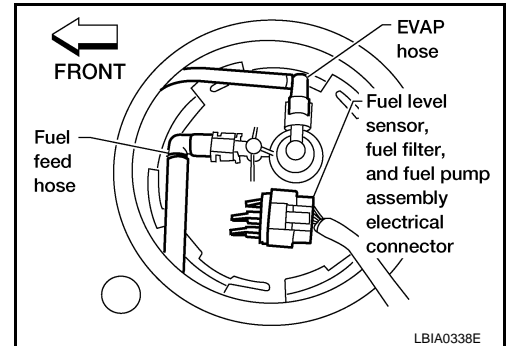

Remove the quick connector as follows:

- Hold the sides of the connector, push in tabs and pull out the tube.
- If the connector and the tube are stuck together, push and pull several times until they start to move. Then disconnect them by pulling.

CAUTION:

- The tube can be removed when the tabs are completely depressed. Do not twist it more than necessary.
- Do not use any tools to remove the quick connector.
- Keep the resin tube away from heat. Be especially careful when welding near the tube.
- Prevent acid liquid such as battery electrolyte, etc. from getting on the resin tube.
- Do not bend or twist the tube during installation and removal.
- Only when the tube is replaced, remove the remaining retainer on the tube or fuel level sensor, fuel filter, and fuel pump assembly.
- When the tube or fuel level sensor, fuel filter, and fuel pump assembly is replaced, also replace the retainer with a new one (green colored retainer).
- To keep the connecting portion clean and to avoid damage and foreign materials, cover them completely with plastic bags or something similar.

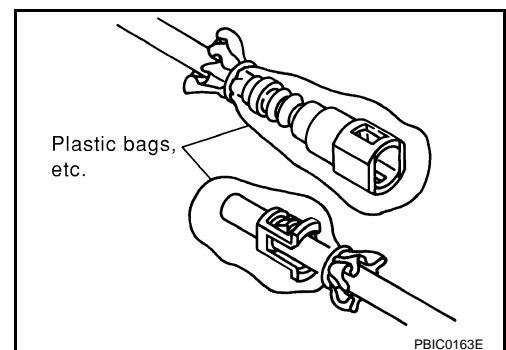
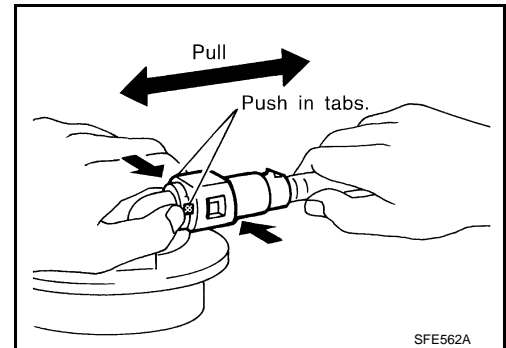

FUEL LEVEL SENSOR UNIT, FUEL FILTER AND FUEL PUMP ASSEMBLY

< ON-VEHICLE REPAIR >

7. Remove the lock ring using a socket drive handle and Tool as shown.

Tool number : KV991J0090 (J-46214)

CAUTION:

- Discard the lock ring, do not reuse the lock ring.
- Discard the ring seal, do not reuse the ring seal.

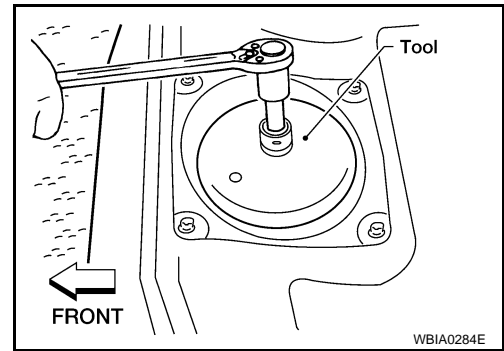

8. Remove the fuel level sensor, fuel filter, and fuel pump assembly.

CAUTION:

- Do not bend the float arm during removal.
- Discard the ring seal, do not reuse the ring seal.

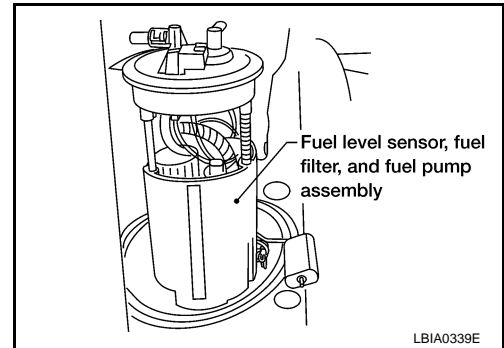

INSPECTION AFTER REMOVAL

Inspect the fuel level sensor, fuel filter, and fuel pump for any defects and foreign materials. Replace as necessary.

INSTALLATION

Installation is in the reverse order of removal.

- Install the fuel level sensor, fuel filter, and fuel pump assembly with the fuel feed hose facing the front of the vehicle as shown. Use a new ring seal.

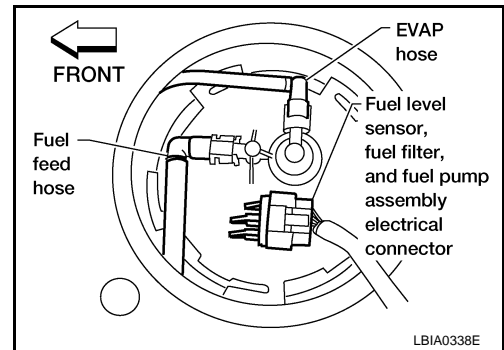

- Connect the quick connector as follows:
 - Check the connection for damage or any foreign materials.
 - Align the connector with the tube, then insert the connector straight into the tube until a click is heard.
- After the tube is connected, make sure the connection is secure by performing the following checks:
 - Pull the tube and the connector to make sure they are securely connected.

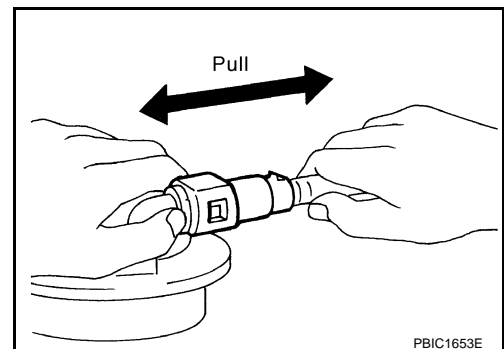

FUEL LEVEL SENSOR UNIT, FUEL FILTER AND FUEL PUMP ASSEMBLY

< ON-VEHICLE REPAIR >

- Visually confirm that the two retainer tabs are connected to the quick connector.

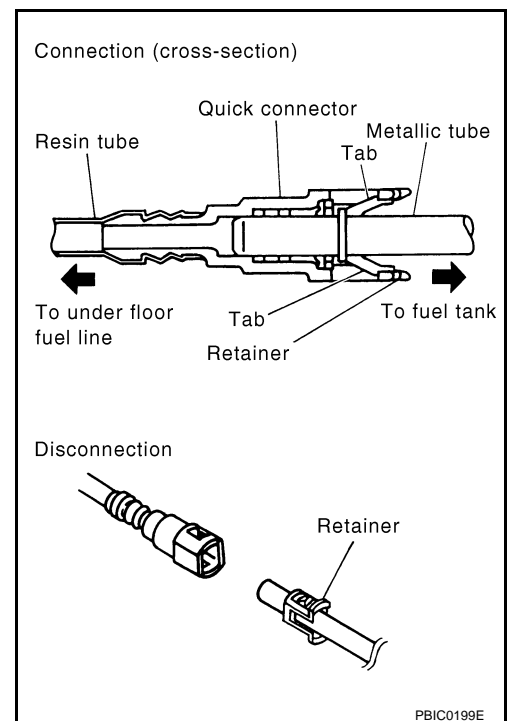

INSPECTION AFTER INSTALLATION

Use the following procedure to check for fuel leaks.

1. Turn the ignition switch to ON (without starting the engine) to apply fuel pressure to the fuel system, then check the connections for fuel leaks.
2. Start the engine and let it idle and check for fuel leaks at the fuel system connections.

Inspection

INFOID:000000000990425

INSPECTION AFTER INSTALLATION

Use the following procedure to check for fuel leaks.

1. Turn ignition switch "ON" (with engine stopped), then check connections for leaks by applying fuel pressure to fuel piping.
2. Start engine and let it idle and make sure there are no fuel leaks at the fuel system connections.

FUEL TANK

< ON-VEHICLE REPAIR >

FUEL TANK

Exploded View

INFOID:000000000990426

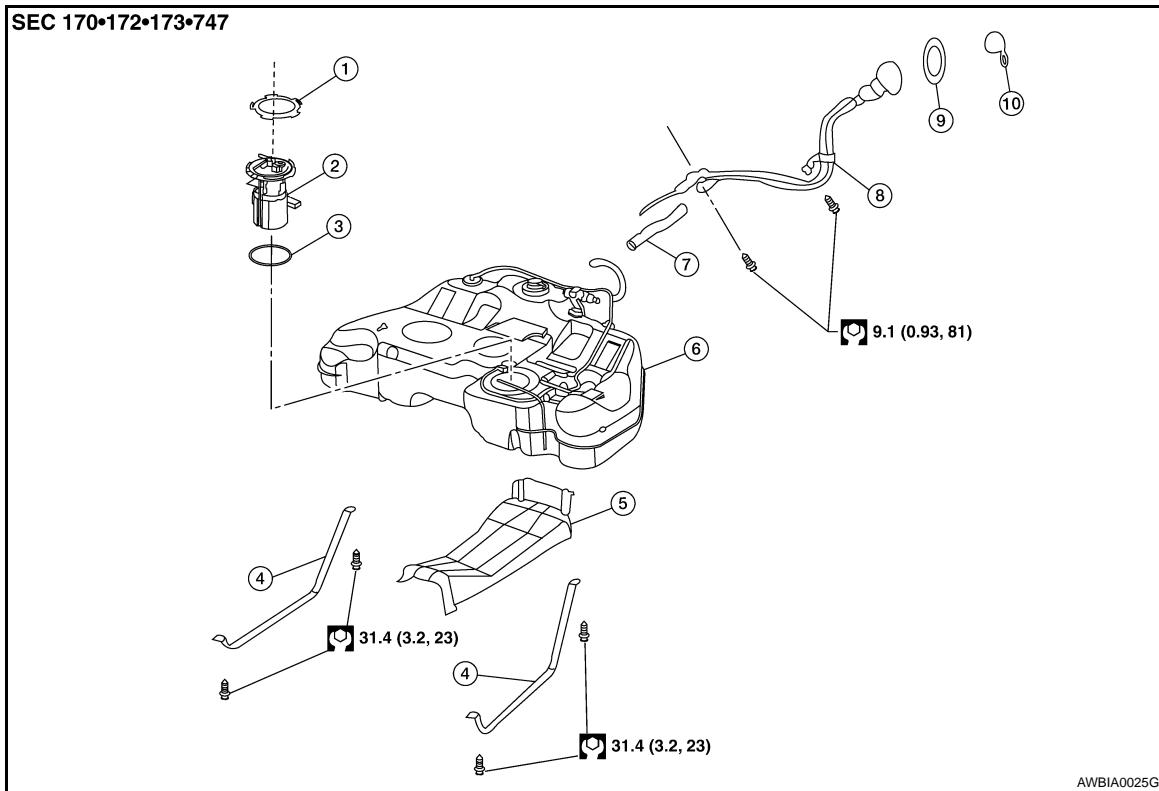

- | | | |
|------------------------------|---|--------------|
| 1. Lock ring | 2. Fuel level sensor, fuel filter, and fuel pump assembly | 3. Seal ring |
| 4. Fuel tank mounting straps | 5. Fuel tank protector | 6. Fuel tank |
| 7. Fuel filler hose | 8. Fuel filler hose | 9. Grommet |
| 10. Fuel filler cap | | |

Removal and Installation

INFOID:000000000990427

REMOVAL

WARNING:

Read "General Precautions" before working on the fuel system. Refer to [FL-5. "General Precaution"](#).

1. Disconnect the battery negative terminal.
2. Check the fuel level with the vehicle on a level surface. If the fuel gauge indicates more than the level as shown (7/8 full), drain the fuel from the fuel tank until the fuel gauge indicates a level at or below as shown (7/8 full).
 - In case the fuel pump does not operate, use the following procedure.
- a. Insert fuel tubing of less than 25mm (0.98in) diameter into the fuel filler tube through the fuel filler opening to drain fuel from the fuel filler tube.
- b. Disconnect the fuel filler hose from the fuel filler tube.
- c. Insert fuel tubing into the fuel tank through the fuel filler hose to drain fuel from the fuel tank.

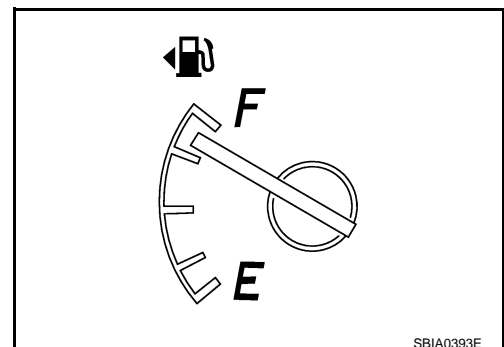

SBIA0393E

FUEL TANK

< ON-VEHICLE REPAIR >

- As a guide, the fuel level reaches or is less than the level on the fuel gauge as shown, when approximately 10 ℓ (2 5/8 US gal, 2 1/4 Imp gal) of fuel is drained from a full fuel tank.
3. Open the fuel filler cap to release the pressure inside the fuel tank.
 4. Release fuel pressure from fuel line, Refer to [PB-5, "PEDAL TYPE : Exploded View"](#) (QR25DE), [EC-522, "Inspection"](#) (VQ35DE).
 5. Remove rear seat bottom. Refer to [SE-21, "Removal and Installation"](#).
 6. Turn the four retainers 90° in a clockwise direction and remove the fuel pump inspection hole cover.

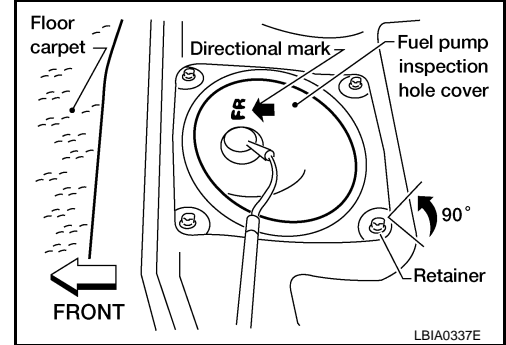

7. Disconnect the fuel level sensor, fuel filter, and fuel pump assembly electrical connector, EVAP hose quick connector, and fuel feed hose quick connector.

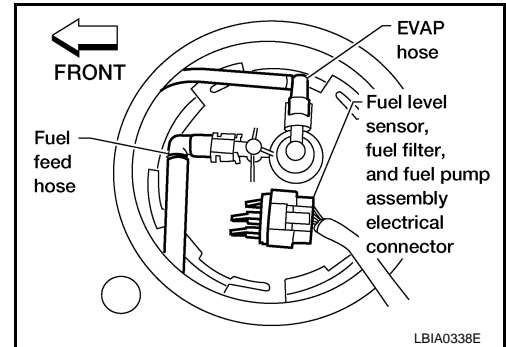

- a. Disconnect the quick connectors as follows:
 - Hold the sides of the connector, push in tabs and pull out the tube.
 - If the connector and the tube are stuck together, push and pull several times until they start to move. Then disconnect them by pulling.

CAUTION:

- The tube can be removed when the tabs are completely depressed. Do not twist it more than necessary.
- Do not use any tools to remove the quick connector.
- Keep the resin tube away from heat. Be especially careful when welding near the tube.
- Prevent acid liquid such as battery electrolyte, from getting on the resin tube.
- Do not bend or twist the tube during installation and removal.
- Only when the tube is replaced, remove the remaining retainer on the tube or fuel level sensor, fuel filter, and fuel pump assembly.
- When the tube or fuel level sensor, fuel filter, and fuel pump assembly is replaced, also replace the retainer with a new one (green colored retainer).
- To keep the connecting portion clean and to avoid damage and foreign materials, cover them completely with plastic bags or something similar.

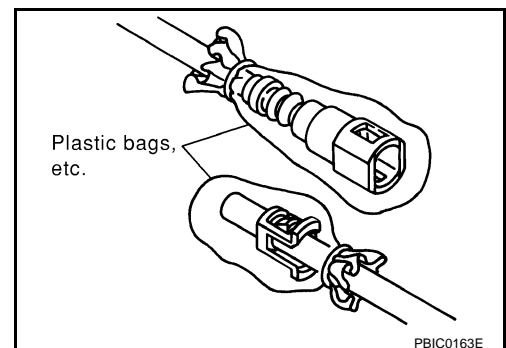
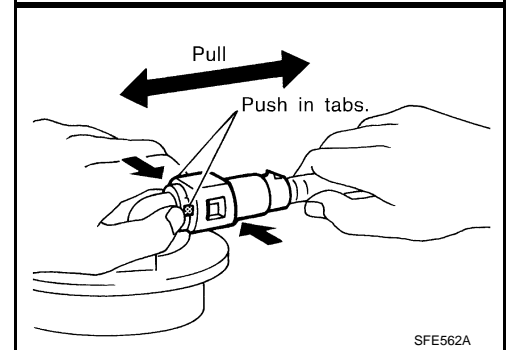

FUEL TANK

< ON-VEHICLE REPAIR >

8. Remove the center exhaust tube, with muffler(s). Refer to [PB-5, "PEDAL TYPE : Exploded View"](#) (QR25DE), [EX-8, "Removal and Installation"](#) (VQ35DE).
9. Disconnect the fuel filler hose and the recirculation hose at the fuel tank side.
10. Disconnect the three parking brake cable mounting brackets on each cable and position the cables out of the way. Refer to [PB-5, "PEDAL TYPE : Exploded View"](#) (pedal), [PB-6, "LEVER TYPE : Exploded View"](#) (lever).
11. Remove the fuel tank protector.
12. Disconnect the fuel tank mounting straps while supporting the fuel tank.
13. Remove the fuel tank.
14. If replacing the fuel tank, remove the fuel level sensor, fuel filter and fuel pump assembly to transfer to the new fuel tank.

INSTALLATION

Install in the reverse order of removal paying attention to the following.

- Before tightening the fuel tank mounting straps, temporarily install the filler hose and the recirculation hose. Tighten all fuel tank mounting strap bolts to specification, then tighten the hose clamps.
- Connect the quick connector as follows:
 - Check the connection for damage or any foreign materials.
 - Align the connector with the tube, then insert the connector straight into the tube until a click is heard.
 - After the tube is connected, make sure the connection is secure by performing the following checks:
 - Pull on the tube and the connector to make sure they are securely connected.
- Visually confirm that the two retainer tabs are connected to the quick connector.

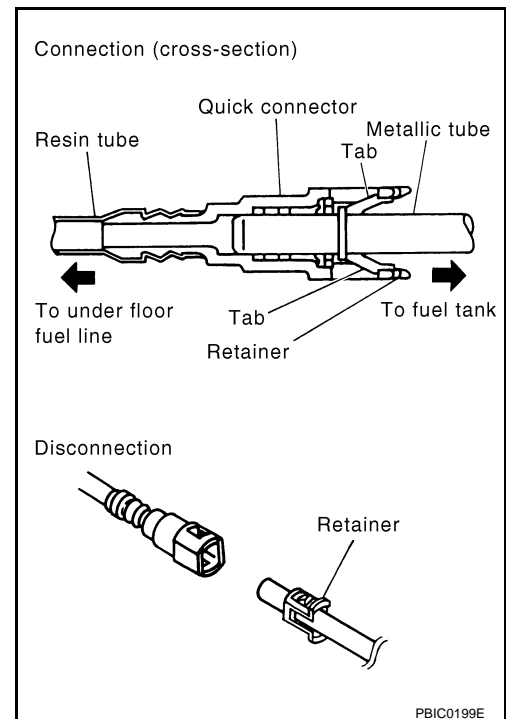
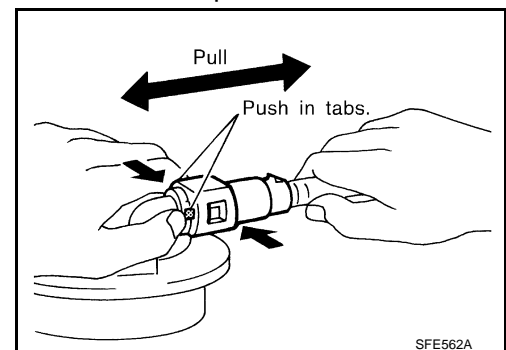

INSPECTION AFTER INSTALLATION

Use the following procedure to check for fuel leaks.

1. Turn the ignition switch ON (without starting the engine). Then check the connections for fuel leaks by applying fuel pressure to the fuel piping.
2. Run the engine and check for fuel leaks at the fuel system tube and hose connections.

Inspection

FUEL TANK

< ON-VEHICLE REPAIR >

INSPECTION AFTER INSTALLATION

Use the following procedure to check for fuel leaks.

1. Turn ignition switch "ON" (with engine stopped), and check connections for leakage by applying fuel pressure to fuel piping.
2. Start engine and rev it up and make sure there are no fuel leaks at the fuel system tube and hose connections.

SERVICE DATA AND SPECIFICATIONS (SDS)

< SERVICE DATA AND SPECIFICATIONS (SDS)

SERVICE DATA AND SPECIFICATIONS (SDS)

SERVICE DATA AND SPECIFICATIONS (SDS)

Fuel Tank

INFOID:000000000990429

A

FL

Standard and Limit

Fuel tank capacity	Approx. 76 ℓ (20 US gal, 16-5/8 Imp gal)
Fuel recommendation	Refer to MA-11, "Fluids and Lubricants"

C

D

E

F

G

H

I

J

K

L

M

N

O

P