

SECTION **BR**
BRAKE SYSTEM

A
B
C
D
E

CONTENTS

<p>PRECAUTIONS 3</p> <p style="padding-left: 20px;">Precautions for Supplemental Restraint System (SRS) "AIR BAG" and "SEAT BELT PRE-TENSIONER" 3</p> <p style="padding-left: 20px;">Precautions for Brake System 3</p> <p>PREPARATION 4</p> <p style="padding-left: 20px;">Special Service Tool 4</p> <p style="padding-left: 20px;">Commercial Service Tools 4</p> <p>NOISE, VIBRATION, AND HARSHNESS (NVH)</p> <p>TROUBLESHOOTING 5</p> <p style="padding-left: 20px;">NVH Troubleshooting Chart 5</p> <p>BRAKE PEDAL 6</p> <p style="padding-left: 20px;">Inspection and Adjustment 6</p> <p style="padding-left: 40px;">INSPECTION 6</p> <p style="padding-left: 40px;">ADJUSTMENT 6</p> <p style="padding-left: 20px;">Removal and Installation 7</p> <p style="padding-left: 40px;">REMOVAL 7</p> <p style="padding-left: 40px;">INSPECTION AFTER REMOVAL 7</p> <p style="padding-left: 40px;">INSTALLATION 7</p> <p>BRAKE FLUID 9</p> <p style="padding-left: 20px;">Checking Brake Fluid Level 9</p> <p style="padding-left: 20px;">Changing Brake Fluid 9</p> <p style="padding-left: 20px;">Bleeding Brake System 9</p> <p>BRAKE PIPING AND HOSE 10</p> <p style="padding-left: 20px;">Hydraulic Circuit 10</p> <p style="padding-left: 20px;">Front Brake Piping and Hose 10</p> <p style="padding-left: 40px;">REMOVAL 10</p> <p style="padding-left: 40px;">INSTALLATION 11</p> <p style="padding-left: 20px;">Rear Brake Piping and Hose 11</p> <p style="padding-left: 40px;">REMOVAL 11</p> <p style="padding-left: 40px;">INSTALLATION 12</p> <p style="padding-left: 20px;">Inspection 13</p> <p>BRAKE MASTER CYLINDER 14</p> <p style="padding-left: 20px;">On-board Inspection 14</p> <p style="padding-left: 40px;">LEAK INSPECTION 14</p> <p style="padding-left: 20px;">Components 14</p> <p style="padding-left: 20px;">Removal and Installation 14</p> <p style="padding-left: 40px;">REMOVAL 15</p>	<p style="padding-left: 20px;">INSTALLATION 15</p> <p style="padding-left: 20px;">Disassembly and Assembly 15</p> <p style="padding-left: 40px;">DISASSEMBLY 15</p> <p style="padding-left: 40px;">INSPECTION AFTER REMOVAL 16</p> <p style="padding-left: 40px;">ASSEMBLY 16</p> <p>BRAKE BOOSTER 17</p> <p style="padding-left: 20px;">On-vehicle Service 17</p> <p style="padding-left: 40px;">OPERATING CHECK 17</p> <p style="padding-left: 40px;">AIRTIGHT CHECK 17</p> <p style="padding-left: 20px;">Removal and Installation 17</p> <p style="padding-left: 40px;">REMOVAL 18</p> <p style="padding-left: 40px;">INSPECTION AFTER REMOVAL 18</p> <p style="padding-left: 40px;">INSTALLATION 18</p> <p>VACUUM LINES 19</p> <p style="padding-left: 20px;">Removal and Installation 19</p> <p style="padding-left: 20px;">Inspection 20</p> <p style="padding-left: 40px;">VISUAL INSPECTION 20</p> <p style="padding-left: 40px;">CHECK VALVE INSPECTION 20</p> <p style="text-align: center;">CLZ25VD</p> <hr/> <p>FRONT DISC BRAKE 21</p> <p style="padding-left: 20px;">Component 21</p> <p style="padding-left: 20px;">On-vehicle Service 21</p> <p style="padding-left: 40px;">PAD WEAR INSPECTION 21</p> <p style="padding-left: 40px;">REMOVAL AND INSTALLATION OF BRAKE PAD 22</p> <p style="padding-left: 20px;">Removal and Installation of Caliper Assembly and Disc Rotor 22</p> <p style="padding-left: 40px;">REMOVAL 22</p> <p style="padding-left: 40px;">INSTALLATION 23</p> <p style="padding-left: 20px;">Disassembly and Assembly of Caliper Assembly... 23</p> <p style="padding-left: 40px;">DISASSEMBLY 23</p> <p style="padding-left: 40px;">INSPECTION AFTER DISASSEMBLY 24</p> <p style="padding-left: 40px;">ASSEMBLY 25</p> <p style="padding-left: 20px;">Brake Burnishing Procedure 26</p> <p style="text-align: center;">CLZ25VE</p> <hr/> <p>FRONT DISC BRAKE 27</p> <p style="padding-left: 20px;">Component 27</p>
--	---

BR

G
H
I
J
K
L
M

On-board Inspection	28	REMOVAL AND INSTALLATION OF BRAKE	
PAD WEAR INSPECTION	28	PAD	34
Removal and Installation of Brake Pad	28	Removal and Installation	35
REMOVAL	28	REMOVAL	35
INSTALLATION	28	INSTALLATION	35
Removal and Installation of Caliper Assembly and		Disassembly and Assembly	36
Disc Rotor	29	DISASSEMBLY	36
REMOVAL	29	CALIPER INSPECTION	37
INSTALLATION	29	ASSEMBLY	37
Disassembly and Assembly of Caliper Assembly...	30	DISC ROTOR INSPECTION	38
DISASSEMBLY	30	Brake Burnishing	39
CALIPER INSPECTION	30	DUAL PROPORTIONING VALVE	40
ASSEMBLY	31	Inspection	40
DISC ROTOR INSPECTION	31	SERVICE DATA AND SPECIFICATIONS (SDS)	41
Brake Burnishing	32	General Specifications	41
REAR DISC BRAKE	33	Disc Brake	41
Component	33	Brake Pedal	42
On-Vehicle Service	34	Control Valve	42
PAD WEAR INSPECTION	34	Brake Booster	42

PRECAUTIONS

PRECAUTIONS

PFP:00001

Precautions for Supplemental Restraint System (SRS) “AIR BAG” and “SEAT BELT PRE-TENSIONER”

EFS007A0

The Supplemental Restraint System such as “AIR BAG” and “SEAT BELT PRE-TENSIONER”, used along with a front seat belt, helps to reduce the risk or severity of injury to the driver and front passenger for certain types of collision. This system includes seat belt switch inputs and dual stage front air bag modules. The SRS system uses the seat belt switches to determine the front air bag deployment, and may only deploy one front air bag, depending on the severity of a collision and whether the front occupants are belted or unbelted. Information necessary to service the system safely is included in the SRS and SB section of this Service Manual.

WARNING:

- To avoid rendering the SRS inoperative, which could increase the risk of personal injury or death in the event of a collision which would result in air bag inflation, all maintenance must be performed by an authorized NISSAN/INFINITI dealer.
- Improper maintenance, including incorrect removal and installation of the SRS, can lead to personal injury caused by unintentional activation of the system. For removal of Spiral Cable and Air Bag Module, see the SRS section.
- Do not use electrical test equipment on any circuit related to the SRS unless instructed to in this Service Manual. SRS wiring harnesses can be identified by yellow and/or orange harnesses or harness connectors.

Precautions for Brake System

EFS0045K

- Always use new brake fluid. Refer to [MA-12. "RECOMMENDED FLUIDS AND LUBRICANTS"](#).
- Never reuse drained brake fluid.
- Be careful not to splash brake fluid on painted areas.
- To clean or wash all parts of master cylinder, disc brake caliper and wheel cylinder, use clean brake fluid.
- Never use mineral oils such as gasoline or kerosene. They will ruin rubber parts of the hydraulic system.
- Use flare nut wrench when removing and installing brake tube.
- Always tighten brake lines to specified torque when installing.
- Burnish the brake contact surfaces after refinishing or replacing drums or rotors, after replacing pads or linings, or if a soft pedal occurs at very low mileage.

WARNING:

- Clean brake pads and shoes with a waste cloth, then wipe with a dust collector.

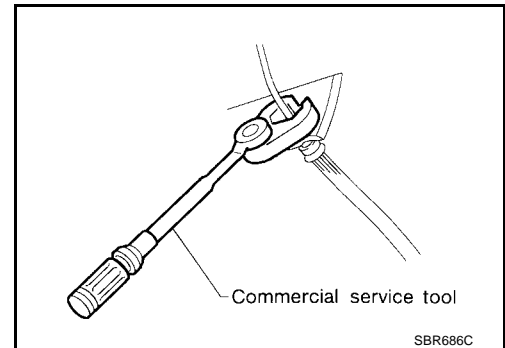

PREPARATION

PREPARATION

PFP:00002

Special Service Tool

EFS004M6

The actual shapes of Kent-Moore tools may differ from those of special service tools illustrated here.

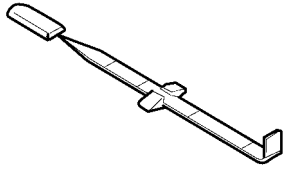
Tool number (Kent-Moore No.) Tool name	Description
<p>— (J-46532) Brake and clutch pedal height measurement tool</p>  <p style="text-align: right; font-size: small;">LFIA0227E</p>	<p>Measuring brake pedal height</p>

Commercial Service Tools

EFS0045M

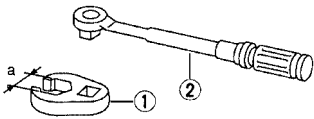
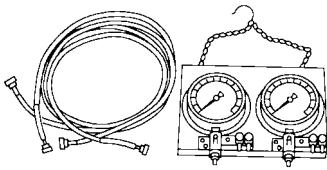
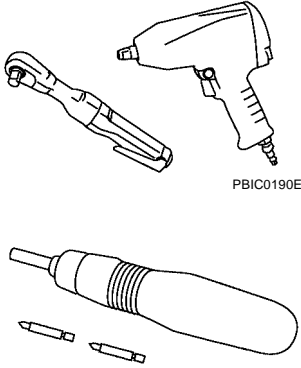
Tool name	Description
<p>1 Flare nut crowfoot 2 Torque wrench</p>  <p style="text-align: right; font-size: small;">S-NT360</p>	<p>Removing and installing each brake piping a: 10 mm (0.39 in)</p>
<p>Brake fluid pressure gauge</p>  <p style="text-align: right; font-size: small;">NT151</p>	<p>Measuring brake fluid pressure</p>
<p>Power tool</p>  <p style="text-align: right; font-size: small;">PBIC0190E PBIC0191E</p>	<p>Loosening nuts, bolts, and screws</p>

NOISE, VIBRATION, AND HARSHNESS (NVH) TROUBLESHOOTING

NOISE, VIBRATION, AND HARSHNESS (NVH) TROUBLESHOOTING

PF0:0003

NVH Troubleshooting Chart

EF50045N

Use the chart below to help you find the cause of the symptom. If necessary, repair or replace these parts.

Symptom		Possible cause and SUSPECTED PARTS															
		Pads - damaged	Pads - uneven wear	Shims damaged	Rotor imbalance	Rotor damage	Rotor runout	Rotor deformation	Rotor deflection	Rotor rust	Rotor thickness variation	DRIVE SHAFT	WHEEL HUB	SUSPENSION	TIRES	ROAD WHEEL	STEERING
Noise	Noise	x	x	x								x	x	x	x	x	x
	Shake				x							x	x	x	x	x	x
	Shimmy, Shudder				x	x	x	x	x	x		x	x	x	x	x	x
Reference page		BR-21, BR-33	BR-21, BR-34	BR-21, BR-33	BR-24, BR-38	BR-21, BR-33	BR-24, BR-38	BR-24, BR-38	BR-24, BR-38	BR-26, BR-26	BR-21, BR-39	FAX-4, "NVH Troubleshooting Chart"	FAX-4, "NVH Troubleshooting Chart", RAX-4, "NVH Troubleshooting Chart"	FSU-4, "NVH Troubleshooting Chart", RSU-4, "NVH Troubleshooting Chart"	WT-3, "NVH Troubleshooting Chart"	WT-3, "NVH Troubleshooting Chart"	PS-5, "NVH Troubleshooting Chart"

x: Applicable

A
B
C
D
E
F
BR
G
H
I
J
K
L
M

BRAKE PEDAL

PFP:46501

EFS00450

BRAKE PEDAL

Inspection and Adjustment INSPECTION

Inspect the brake pedal free height "H" from dash reinforcement panel using Tool. Adjust if necessary. Refer to [BR-6, "ADJUSTMENT"](#).

Tool : — (J-46532)

- Input rod (A)
- Floor carpet (B)
- Dash insulator (C)
- Floor panel (D)
- Dash reinforcement panel (E)
- Dash insulator (F)
- Floor carpet (G)
- Gap (I1, I2)
- Stop lamp switch and ASCD switch (J)

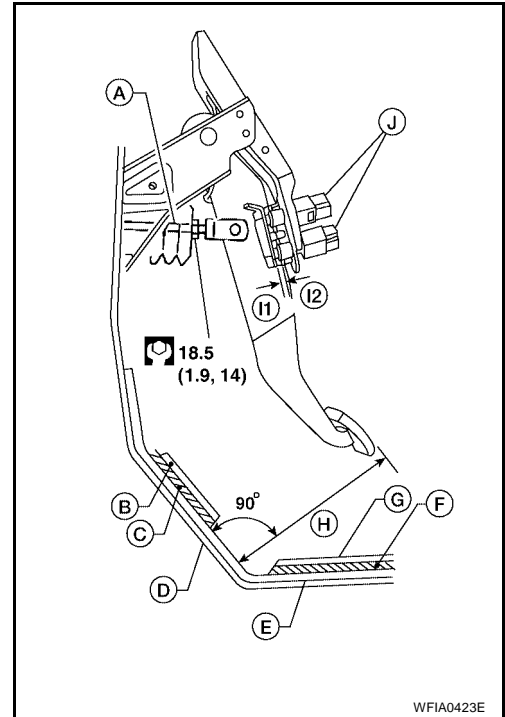

Unit: mm (in)

Free height "H"	: Refer to BR-42, "Brake Pedal" .	
Clearance between pedal stopper and threaded end of stop lamp switch and ASCD switch "I1, I2"	: 0.74 - 1.96 (0.0291 - 0.0772)	
Pedal height (with engine running, brake pedal force 490 N {50 kg-f, 110 lb-f}) "H"	M/T	: More than 84 (3.31)
	A/T	: More than 90.3 (3.55)
Pedal play	: 3 - 11 (0.12 - 0.43)	

ADJUSTMENT

1. Loosen the stop lamp switch and ASCD switch (if equipped) by turning 45° counterclockwise.
2. Loosen lock nut on the input rod.

CAUTION:

Make sure that the screw portion of the end of input rod is located inside the clevis as shown.

3. Turn input rod to adjust the pedal to specified height. Refer to [BR-6, "INSPECTION"](#) . When finished adjusting, tighten lock nut to specification. Refer to [BR-17, "Removal and Installation"](#) .
4. With the pedal pulled up and held by hand, press the stop lamp switch and the ASCD switch (if equipped) in until threaded ends contact rubber stops.
5. With the threaded ends of the stop lamp switch and ASCD switch (if equipped) contacting the rubber stops, turn the switches 45° clockwise to lock in place.

CAUTION:

Make sure that the gap (I¹ , I²) between the rubber stops and switch ends are within specification.

6. Check the pedal play.

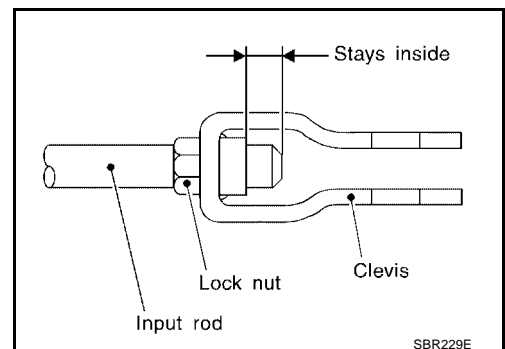

BRAKE PEDAL

CAUTION:

Make sure that the stop lamp goes off when the pedal is released.

7. Start the engine and check the height of the brake pedal when depressing it.

Removal and Installation

EFS0045P

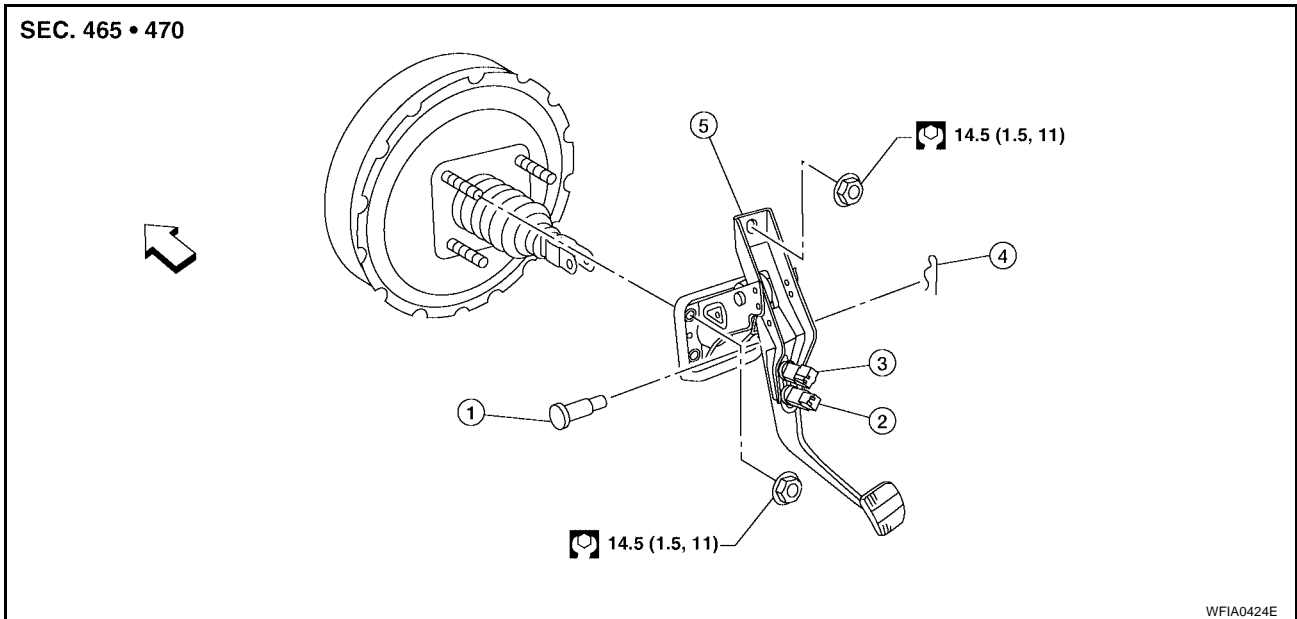

- | | | |
|---------------|-------------------------|-----------------------|
| 1. Clevis Pin | 2. Stop lamp switch | 3. ASCD cancel switch |
| 4. Snap pin | 5. Brake pedal assembly | ← Front |

REMOVAL

WARNING:

Do not deform the brake tube.

1. Remove the instrument lower cover LH. Refer to [IP-13, "INSTRUMENT LOWER COVER LH"](#).
2. Remove the stop lamp switch from the pedal assembly.
3. Remove ASCD switch (if equipped) from pedal assembly.
4. Remove snap pin and clevis pin from the clevis of brake booster.
5. Remove mounting nuts from the pedal assembly and carefully remove the brake pedal from the brake booster.

CAUTION:

Temporarily secure brake booster to bulkhead with a hand tightened nut, to prevent damaging to brake tubes.

INSPECTION AFTER REMOVAL

Check brake pedal for following items.

- Crack or deformation of clevis pin stopper
- Clevis pin deformation
- Crack of any welded portion
- Brake pedal bend

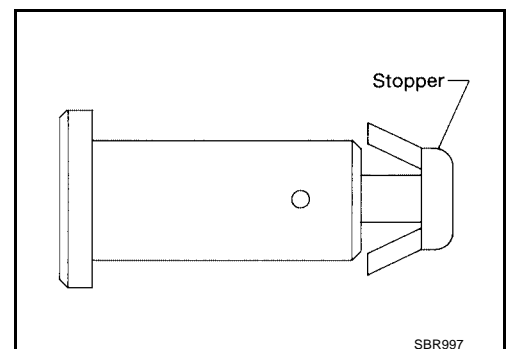

INSTALLATION

Installation is in the reverse order of removal.

BRAKE PEDAL

- After installing the brake pedal assembly in the vehicle, be sure to adjust it. Refer to [BR-6, "Inspection and Adjustment"](#) .

BRAKE FLUID

Checking Brake Fluid Level

EFS0045Q

- Check fluid level in reservoir tank. It should be between Max and Min lines on reservoir tank.
- Visually check around the reservoir tank for leaks.
- If fluid level is extremely low, check brake system for leaks.
- Release parking brake lever and see if brake warning lamp goes off. If not, check brake system for leaks.

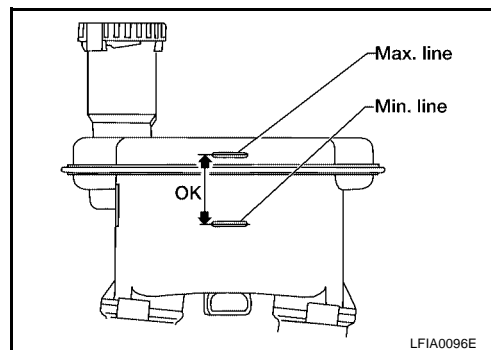

EFS0045R

Changing Brake Fluid

CAUTION:

- Refill with new brake fluid. Refer to [MA-12, "RECOMMENDED FLUIDS AND LUBRICANTS"](#) .
 - Always keep fluid level higher than minimum line on reservoir tank.
 - Never reuse drained brake fluid.
 - Be careful not to splash brake fluid on painted areas; it may cause paint damage. If brake fluid is splashed on painted areas, wash it away with water immediately.
1. Connect a vinyl tube and container to the air bleeder.
 2. Depressing the brake pedal, drain the brake fluid gradually from the air bleeder of each wheel.
 3. Turn the ignition switch to OFF and disconnect the ABS actuator and control unit connector.
 4. Clean inside of reservoir tank, and refill with new brake fluid.
 5. Loosen the air bleeder, depress the pedal slowly to the full stroke and then release it. Repeat the procedure every 2 or 3 seconds until the new brake fluid comes out, then close the air bleeder while depressing the pedal. Refer to [BR-9, "Bleeding Brake System"](#) .

Bleeding Brake System

EFS0045S

CAUTION:

- Carefully monitor brake fluid level at master cylinder during bleeding operation.
 - Fill reservoir with new brake fluid. Refer to [MA-12, "RECOMMENDED FLUIDS AND LUBRICANTS"](#) . Make sure it is full at all times while bleeding air out of system.
 - Place a container under master cylinder to avoid spillage of brake fluid.
 - Do not loosen the connecting portion of the actuator during air bleeding.
1. For models with ABS, turn ignition switch OFF and disconnect ABS actuator and control unit connectors or battery ground cable.
 2. Connect a transparent vinyl tube and container to air bleeder valve.
 3. Fully depress brake pedal several times.
 4. With brake pedal depressed, open air bleeder valve to release air.
 5. Close air bleeder valve.
 6. Release brake pedal slowly.
 7. Tighten air bleeder valve to specification.
Air bleeder valve : 8 N-m (0.8 kg-m, 69 in-lb)
 8. Repeat steps 2. through 7. until no more air bubbles come out of air bleeder valve.
 9. Bleed the brake hydraulic system air bleeder valves in the following order:
Right rear brake → Left front brake → Left rear brake → Right front brake

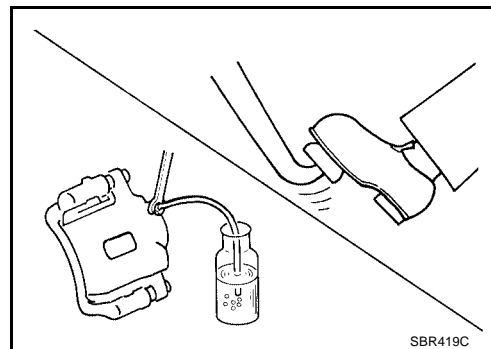

BRAKE PIPING AND HOSE

BRAKE PIPING AND HOSE

PFP:46210

Hydraulic Circuit

EFS0045T

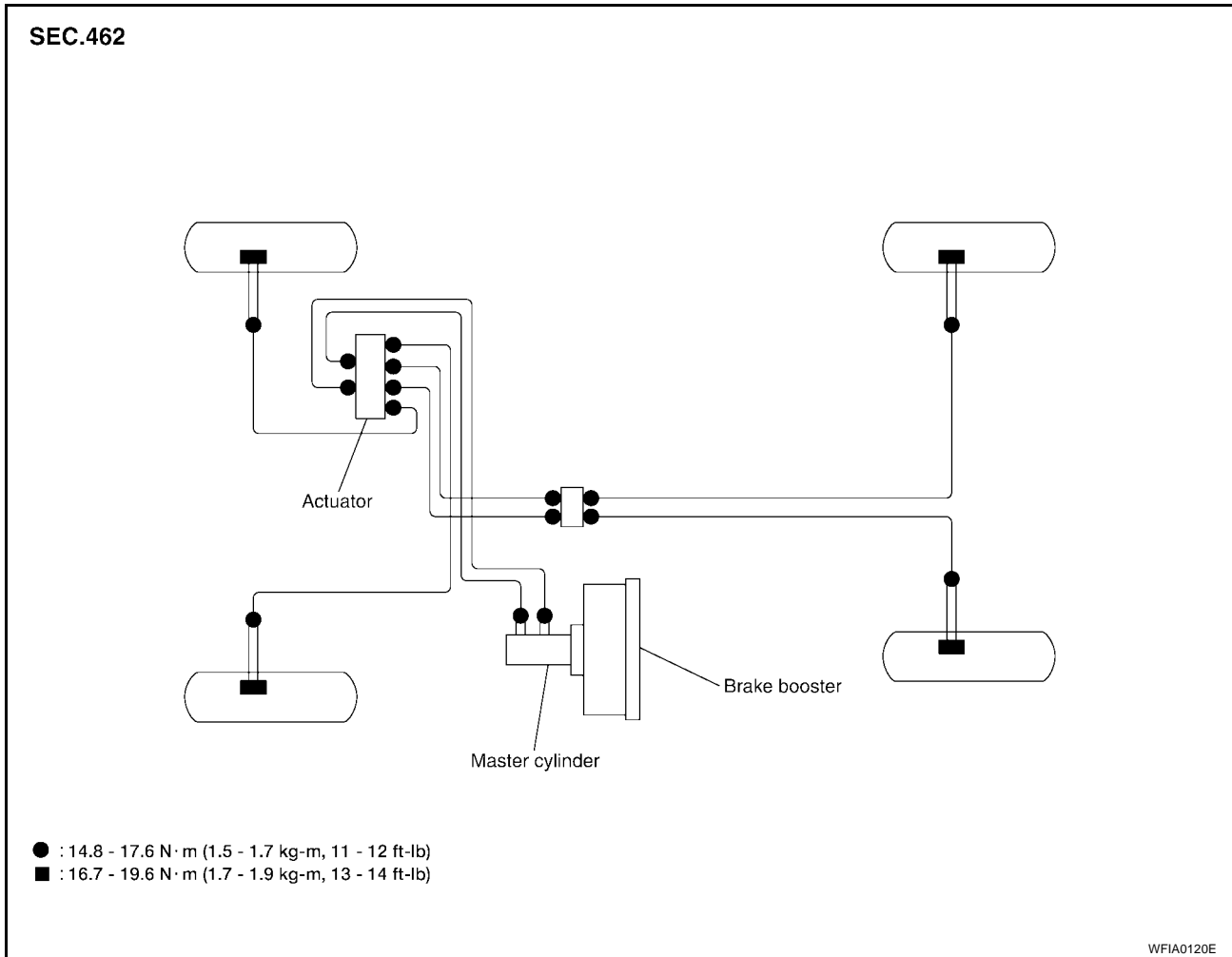

Front Brake Piping and Hose REMOVAL

EFS0045U

CAUTION:

- Be careful not to splash brake fluid on painted areas; it may cause paint damage. If brake fluid is splashed on painted areas, wash it away with water immediately.
 - All hoses must be free from excessive bending, twisting and pulling.
 - Cover the open end of lines and hoses when disconnecting to prevent entrance of dirt.
1. Connect vinyl tube and container to air bleeder valve.
 2. Drain brake fluid from each air bleeder valve by depressing brake pedal.

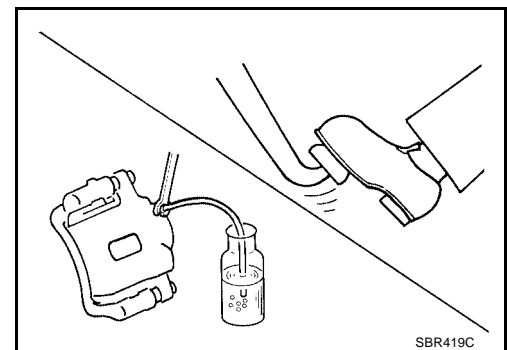

BRAKE PIPING AND HOSE

3. Remove the flare nut connecting the brake tube and hose, then withdraw the lock spring.
4. Remove the connecting bolt and disconnect the brake hose from the cylinder body.
5. Remove lock spring from the mounting portion of the brake tube and the mounting portion of the strut.

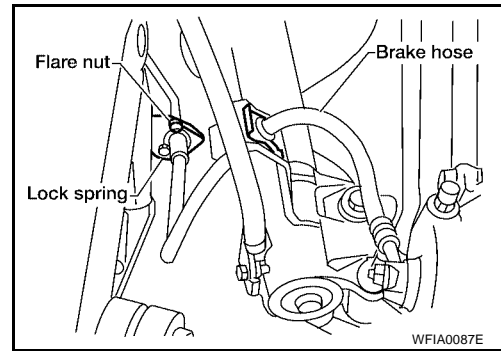

INSTALLATION

CAUTION:

- Refill with new brake fluid. Refer to [MA-12, "RECOMMENDED FLUIDS AND LUBRICANTS"](#) .
 - Never reuse drained brake fluid.
1. Attach the brake hose to the cylinder body, then temporarily tighten the connecting bolt by hand.

CAUTION:

- Correctly attach the brake hose to the cylinder body.
 - The copper washers of the connecting bolt have to be replaced with new ones every time the fitting is disconnected.
2. Attach the brake hose to the strut, then secure it with a lock spring.
 3. Attach the brake hose to the brake tube and temporarily tighten the flare nut as much as possible by hand, then secure it with a lock spring.
 4. Tighten all flare nuts and connecting bolts to specification, using tool. Refer to [BR-10, "Hydraulic Circuit"](#) .

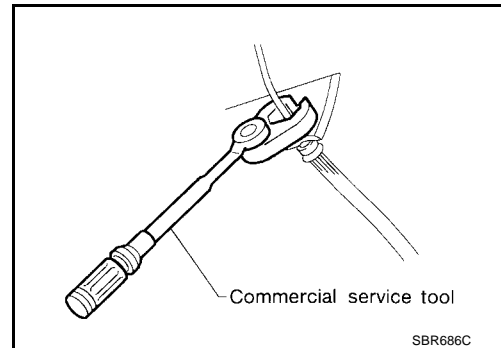

5. Refill until new brake fluid comes out of each air bleeder valve.
6. Bleed air. Refer to [BR-9, "Bleeding Brake System"](#) .

Rear Brake Piping and Hose REMOVAL

EFS0045V

CAUTION:

- Be careful not to splash brake fluid on painted areas; it may cause paint damage. If brake fluid is splashed on painted areas, wash it away with water immediately.
 - All hoses must be free from excessive bending, twisting and pulling.
 - Cover the open end of lines and hoses when disconnecting to prevent entrance of dirt.
1. Connect vinyl tube and container to air bleeder valve.

BRAKE PIPING AND HOSE

2. Drain brake fluid from each air bleeder valve by depressing brake pedal.

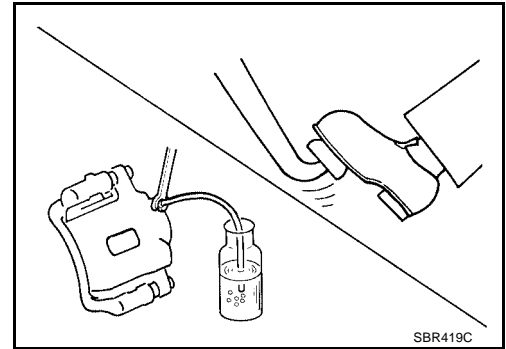

3. Remove flare nut connecting brake tube and hose, then withdraw lock spring.
4. Remove connecting bolt and disconnect brake hose from cylinder body.

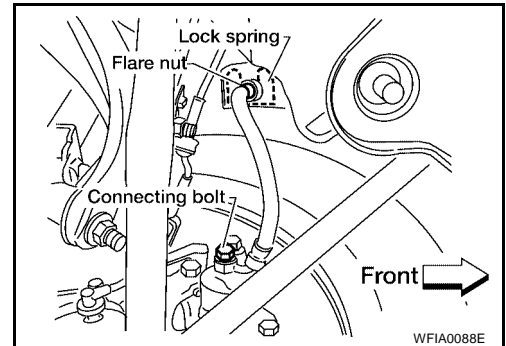

INSTALLATION

CAUTION:

- Refill with new brake fluid. Refer to [MA-12, "RECOMMENDED FLUIDS AND LUBRICANTS"](#).
 - Never reuse drained brake fluid.
1. Attach the brake hose to the brake tube and temporarily tighten the flare nut as much as possible by hand.

CAUTION:

- Correctly attach the brake hose to the cylinder body.
 - The copper washers of the connecting bolt have to be replaced with new ones every time the fitting is disconnected.
2. Attach the brake hose with a lock spring, then tighten flare nut and connecting bolt to specification, using tool. Refer to [BR-10, "Hydraulic Circuit"](#).

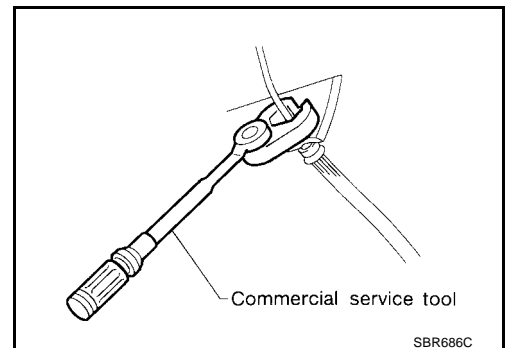

3. Refill until new brake fluid comes out of each air bleeder valve.
4. Bleed air from the brake system. Refer to [BR-9, "Bleeding Brake System"](#).

BRAKE PIPING AND HOSE

Inspection

EFS0045W

CAUTION:

If leakage occurs around hose and tube connections, retighten or, if necessary, replace damaged parts.

1. Check brake lines (tubes and hoses) for leaks, cracks, distortion, deformation, without interfering with other parts or loosening connecting parts, deterioration or other damage. Replace any damaged parts.
2. Apply a stepping force of 784 N (80 kg-f, 176 lb-f) to the brake pedal with the engine running and keep it for about 5 seconds, then check each part for leaks.

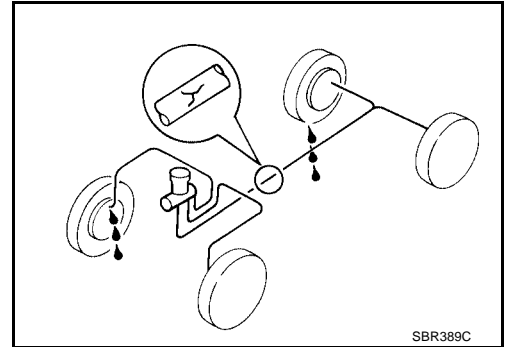

A
B
C
D
E

BR

G
H
I
J
K
L
M

BRAKE MASTER CYLINDER

PFP:46010

BRAKE MASTER CYLINDER

On-board Inspection LEAK INSPECTION

EFS0045X

Check for leaking in master cylinder installation surface, the reservoir tank installation surface, the reservoir hose connections, and the brake tube connections.

Components

EFS0045Y

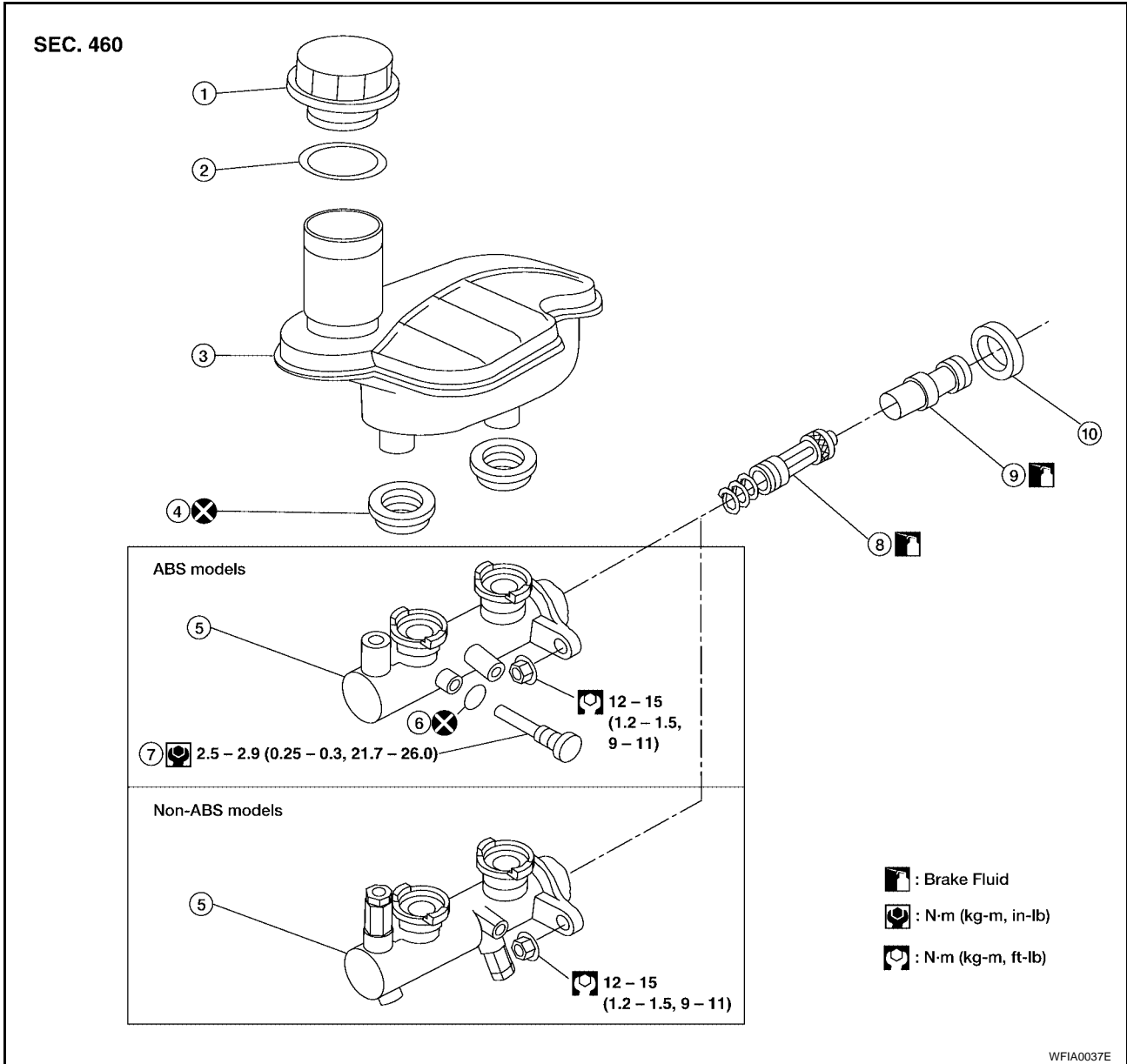

- | | | |
|-------------------|------------------------------|----------------------------|
| 1. Reservoir cap | 2. O-ring | 3. Reservoir tank |
| 4. Seal | 5. Cylinder body | 6. O-ring |
| 7. Piston stopper | 8. Secondary piston assembly | 9. Primary piston assembly |
| 10. Stopper cap | | |

Removal and Installation

EFS0045Z

CAUTION:

Be careful not to splash brake fluid on painted areas; it may cause paint damage. If brake fluid is splashed on painted areas, wash it away with water immediately.

BRAKE MASTER CYLINDER

REMOVAL

1. Remove air cleaner and inlet duct. Refer to [EM-17, "Removal and Installation"](#) (QR25DE), [EM-118, "Removal and Installation"](#) (VQ35DE).
2. Remove clutch fluid reservoir without disconnecting hose and position aside. Refer to [CL-8, "CLUTCH MASTER CYLINDER"](#).
3. Connect a vinyl tube and container to air bleeder valve.
4. Drain brake fluid from each air bleeder valve by depressing brake pedal to empty fluid from the master cylinder. Remove the harness connector of the brake fluid master cylinder level sensor.
5. Remove brake pipe flare nuts.
6. Disconnect fluid level sensor.
7. Remove master cylinder nuts and master cylinder.
8. Remove reservoir tank and seals, if necessary.

INSTALLATION

CAUTION:

- Refill with new brake fluid. Refer to [MA-12, "RECOMMENDED FLUIDS AND LUBRICANTS"](#).
- Never reuse drained brake fluid.

Installation is in the reverse order of removal.

- Plug all ports on master cylinder with fingers to prevent air suction while releasing brake pedal.
- Have driver depress brake pedal slowly several times until no air comes out of master cylinder.
- Install the brake lines to master cylinder.
- Tighten flare nuts to specification. Refer to [BR-10, "BRAKE PIPING AND HOSE"](#).
- Bleed air from the brake system. Refer to [BR-9, "Bleeding Brake System"](#).

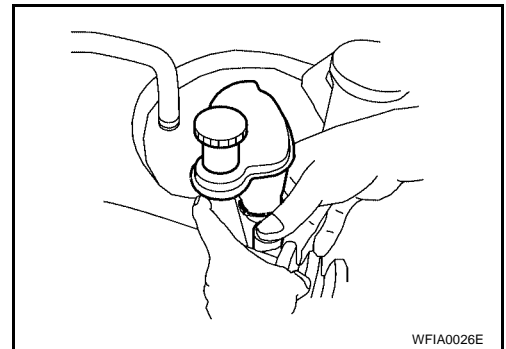

EFS00460

Disassembly and Assembly

DISASSEMBLY

1. Bend claws of stopper cap outward.

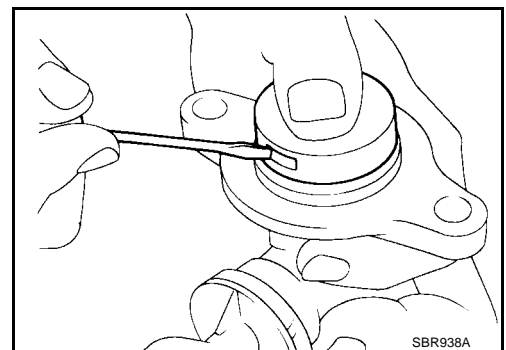

2. Remove piston stopper while piston is pushed into cylinder.
3. Remove piston assemblies.
If it is difficult to remove secondary piston assembly, gradually apply compressed air through fluid outlet.
4. Remove the reservoir tank.

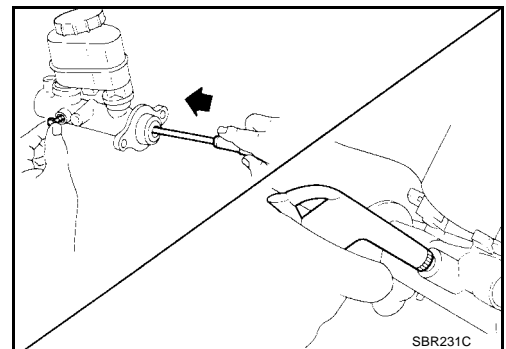

BRAKE MASTER CYLINDER

INSPECTION AFTER REMOVAL

Master Cylinder Inner Wall

- Check the inner wall of the cylinder for damage, abrasion, corrosion and pin holes. If defective, replace the master cylinder.

Piston

- Check for deformation of or scratches on piston cups.

ASSEMBLY

1. Insert secondary piston assembly. Then insert primary piston assembly.
 - Pay attention to alignment of secondary piston slit with piston stopper mounting hole of cylinder body.

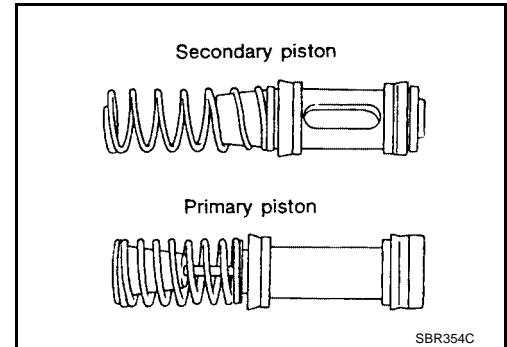

2. Install stopper cap.
Before installing stopper cap, ensure that claws are bent inward.

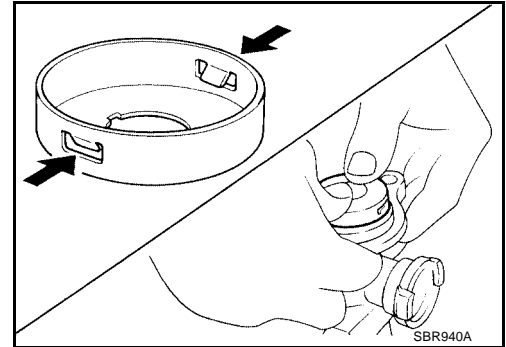

3. Push reservoir tank seals into cylinder body.
4. Push reservoir tank into cylinder body.
5. Install piston stopper while piston is pushed into cylinder.

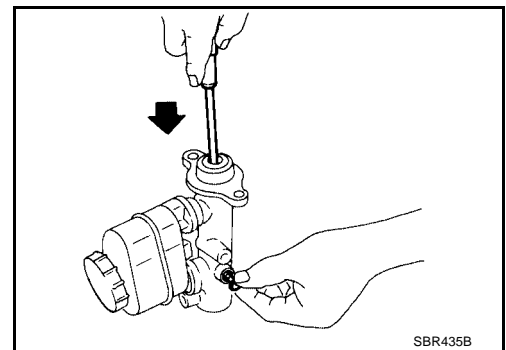

BRAKE BOOSTER

PFP:47200

EFS00461

BRAKE BOOSTER

On-vehicle Service OPERATING CHECK

1. Stop engine and depress brake pedal several times. Check that pedal stroke does not change.
2. Depress brake pedal, then start engine. If pedal goes down slightly, operation is normal.

CAUTION:

Depress brake pedal in 5 second intervals.

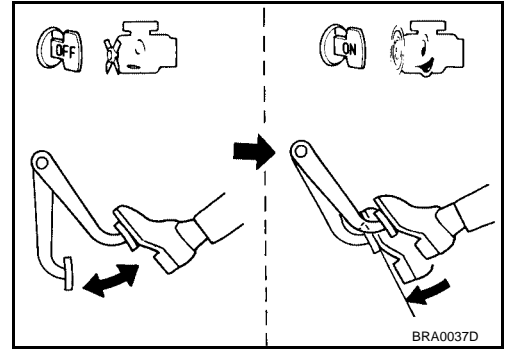

AIRTIGHT CHECK

- Start engine, and stop it after one or two minutes. Depress brake pedal several times slowly. The pedal should go further down the first time, and then it should gradually rise thereafter.
- Depress brake pedal while engine is running, and stop engine with pedal depressed. The pedal stroke should not change after holding pedal down for 30 seconds.

CAUTION:

Depress brake pedal in 5 second intervals.

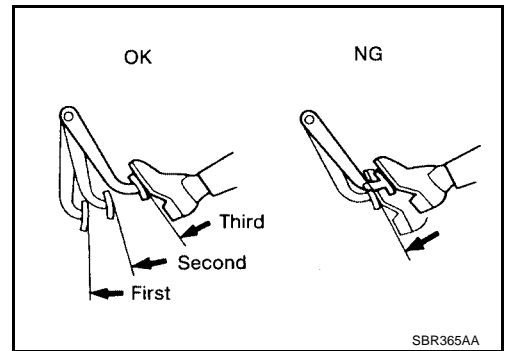

Removal and Installation

EFS00462

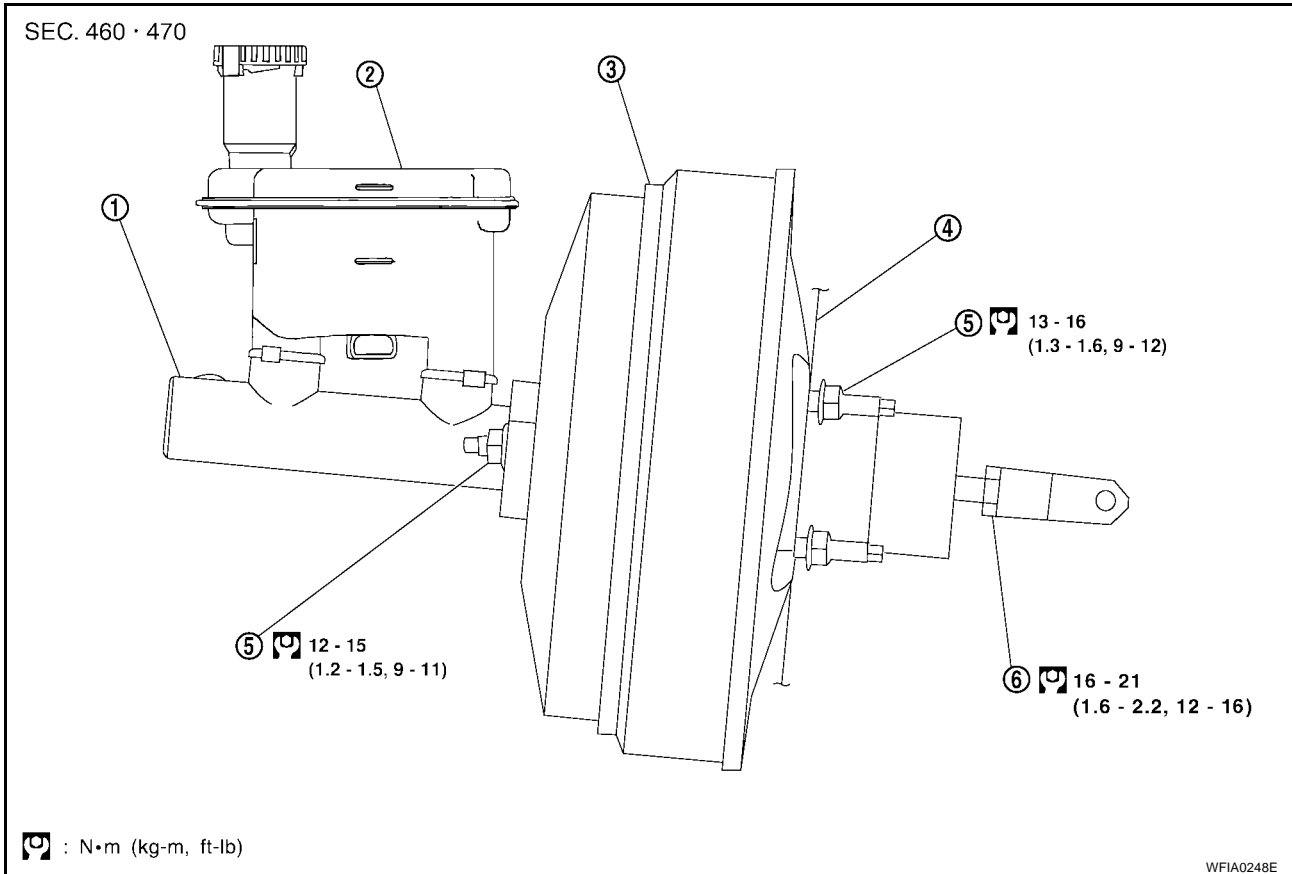

BRAKE BOOSTER

- | | | |
|--------------------|-------------------|------------------|
| 1. Master cylinder | 2. Reservoir tank | 3. Brake booster |
| 4. Gasket | 5. Nut | 6. Lock nut |

REMOVAL

CAUTION:

- Be careful not to splash brake fluid on painted areas; it may cause paint damage. If brake fluid is splashed on painted areas, wash it away with water immediately.
 - Be careful not to deform or bend brake pipes during removal of booster.
 - Replace clevis pin if damaged.
 - Refill with new brake fluid. Refer to [MA-12, "RECOMMENDED FLUIDS AND LUBRICANTS"](#) .
 - Never reuse drained brake fluid.
 - Take care not to damage brake booster mounting bolt thread when installing. Due to the acute angle of installation, the threads can be damaged with the dash panel.
1. Remove air cleaner and inlet duct. Refer to [EM-17, "Removal and Installation"](#) (QR25DE), [EM-17, "AIR CLEANER AND AIR DUCT"](#) (VQ35DE).
 2. Remove clutch fluid reservoir without disconnecting hose and position aside. Refer to [CL-9, "CLUTCH RESERVOIR TANK"](#) .
 3. Remove the brake master cylinder. Refer to [BR-14, "Removal and Installation"](#) .
 4. Remove vacuum hose from the brake booster. Refer to [BR-19, "Removal and Installation"](#) .
 5. Remove instrument lower cover LH. Refer to [IP-13, "INSTRUMENT LOWER COVER LH"](#) .
 6. Remove the brake pedal attachment snap pin and clevis pin from inside the vehicle.
 7. Remove the nuts on the brake booster and brake pedal assembly.
 8. Remove brake booster assembly from the engine compartment side.

INSPECTION AFTER REMOVAL

Output Rod Length Check

1. Apply vacuum of -66.7 kPa (-500 mmHg, -19.69 inHg) to brake booster with a hand vacuum pump.
2. Add preload of 19.6 N (2 kg, 4.4 lb) to output rod.
3. Check output rod length.

**Specified length : 10.275 - 10.525 mm
(0.4045 - 0.4144 in)**

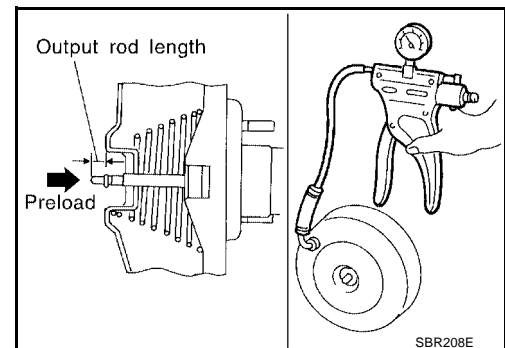

INSTALLATION

Installation is in the reverse order of removal.

- Adjust the length of the input rod by loosening the lock nut so that the dimensions shown match the standard value.

Standard value : 125 mm (4.92 in)

- Tighten the lock nut temporarily and when installing the booster assembly in the vehicle.
- Adjust the height and play of the brake pedal. Refer to [BR-6, "Inspection and Adjustment"](#) .
- Bleed air from brake system. Refer to [BR-9, "Bleeding Brake System"](#) .

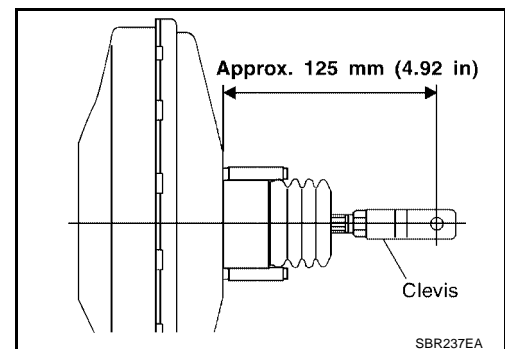

VACUUM LINES

VACUUM LINES

Removal and Installation

PFV:41920

EFS00463

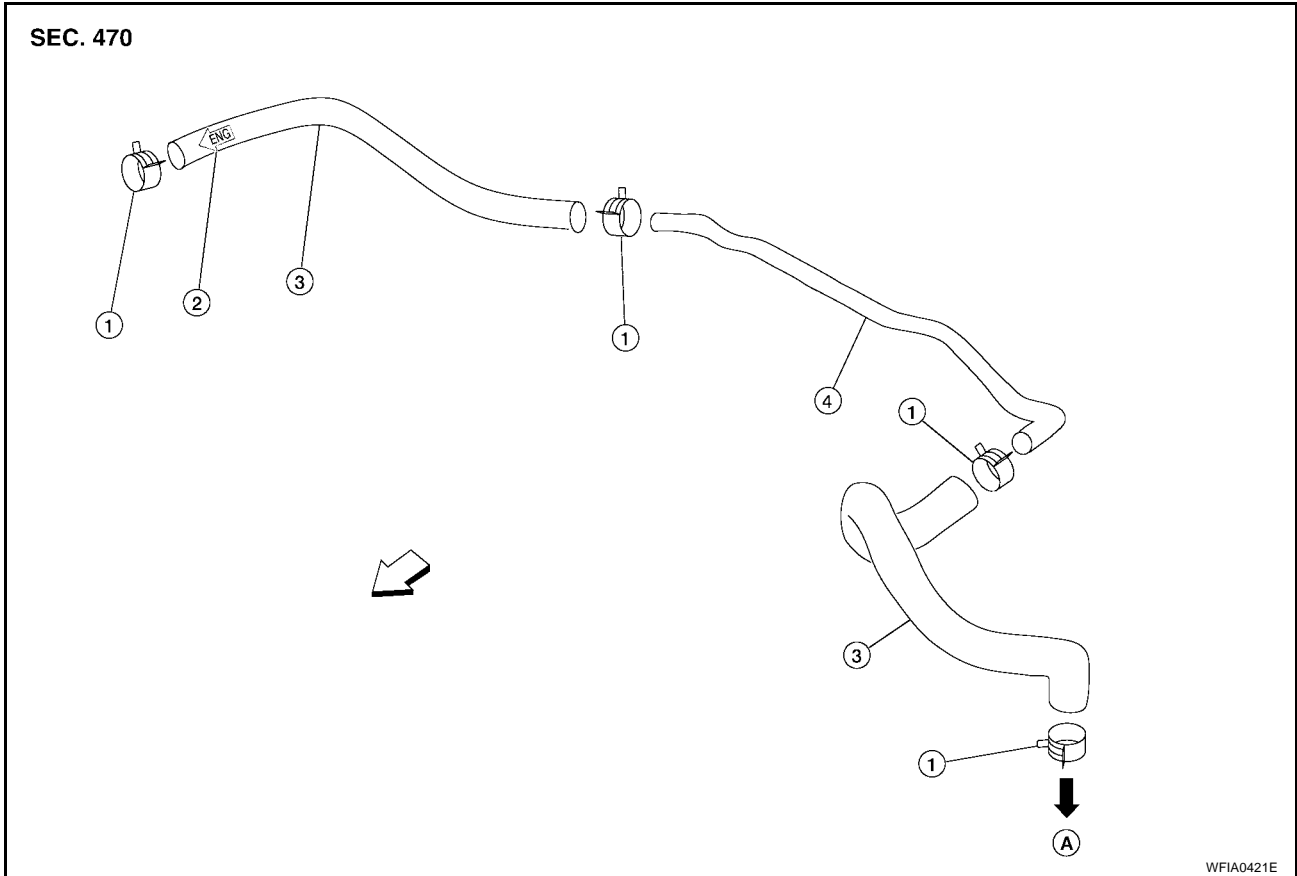

1. Clamp
 2. Check valve inclusion position stamp
 3. Vacuum hose
 4. Vacuum piping
- ← Brake booster

CAUTION:

- Because vacuum hose contains a check valve, it must be installed in the correct orientation. Refer to the stamp or label to confirm correct installation. The brake booster will not operate normally if the hose is installed in the wrong direction.
- Insert the vacuum hose at least 24 mm (0.94 in).
- Never use lubricating oil during assembly.

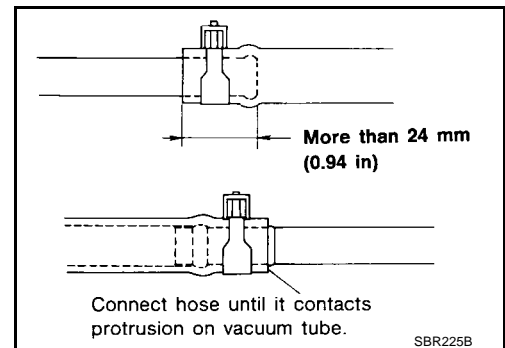

VACUUM LINES

EFS00464

Inspection

VISUAL INSPECTION

Check for improper assembly, damage and deteriorate.

CHECK VALVE INSPECTION

Airtightness Inspection

Use a hand-held vacuum pump to check.

When connected to booster side:

Vacuum decrease should be within 1.3 kPa (10 mmHg, 0.39 inHg) for 15 seconds under a vacuum of (-66.7 kPa) [(-500 mmHg), (-19.69 inHg)]

When connected to engine side:

No vacuum will be applied

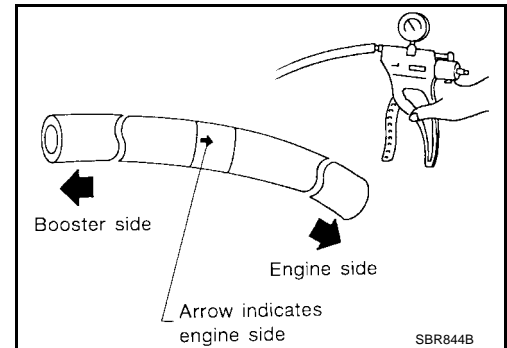

FRONT DISC BRAKE

PFP:41000

Component

EFS00465

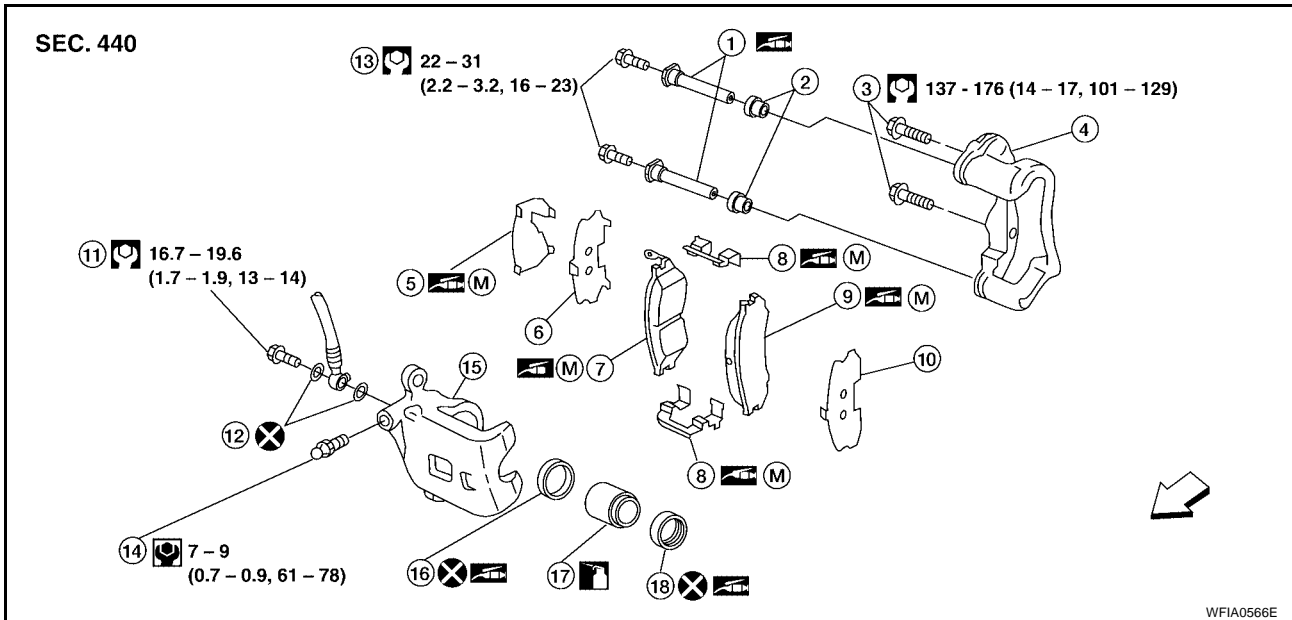

- | | | |
|--|---------------------|-----------------------|
| 1. Main pin (apply grease only to sliding portion) | 2. Pin boot | 3. Torque member bolt |
| 4. Torque member | 5. Shim cover | 6. Inner shim |
| 7. Inner pad | 8. Pad retainer | 9. Outer pad |
| 10. Outer shim | 11. Connecting bolt | 12. Copper washer |
| 13. Main pin bolt | 14. Bleed valve | 15. Cylinder body |
| 16. Piston seal | 17. Piston | 18. Piston boot |
- ← Front

WARNING:

Clean brake pads with a vacuum dust collector to minimize the hazard of airborne particles or other materials.

CAUTION:

- When cylinder body is open, do not depress the brake pedal because the piston will pop out.
- It is not necessary to remove connecting bolt except for disassembly or replacement of cylinder body. In this case, suspend cylinder body with wire so as not to stretch brake hose.
- Be careful not to damage piston boot or get oil on rotor. Always replace shims when replacing pads.
- Burnish the brake contact surfaces after refinishing or replacing rotors, after replacing pads, or if a soft pedal occurs at very low mileage.
Refer to [BR-26, "Brake Burnishing Procedure"](#).

On-vehicle Service PAD WEAR INSPECTION

EFS00466

- Remove a wheel with the vehicle lifted up, and then check the thickness of the pad from the inspection hole of the cylinder body. If necessary, check it with a micrometer.

Standard pad thickness : 11 mm (0.43 in)
Pad wear limit : 2.0 mm (0.079 in)

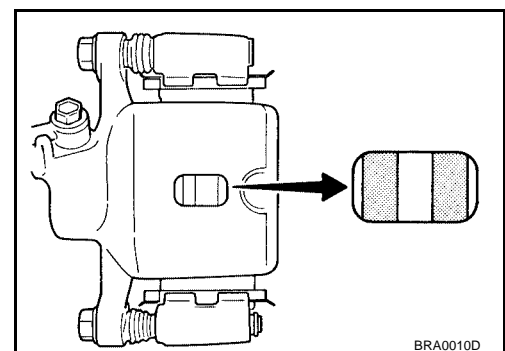

BRA0010D

REMOVAL AND INSTALLATION OF BRAKE PAD

Removal

- If shims are rusted or show peeling of the rubber coat, replace them with new shims.
 - Whenever the brake pads are replaced, the inner shim, the outer shim and the shim cover have to be replaced as a set.
1. Remove master cylinder reservoir cap.
 2. Remove pin bolt, using power tool.

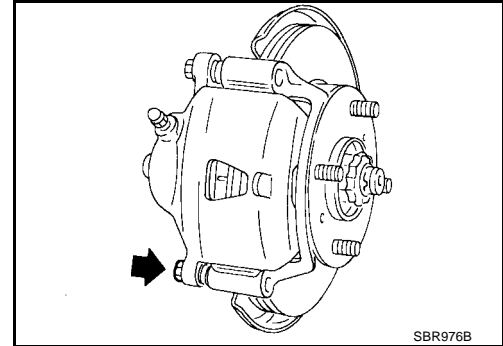

3. Suspend the cylinder body with wire. Then remove pads with retainers, inner and outer shims and pad return springs.

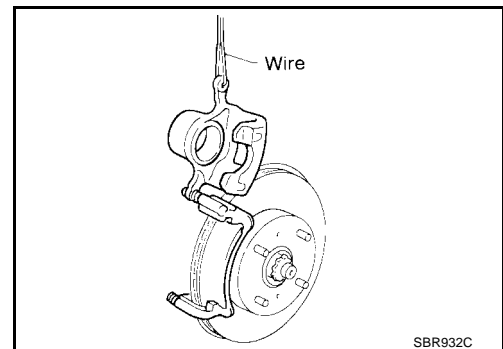

Installation

1. Apply Molykote M-77 grease between pad plate and shim, shim and shim cover, and shim cover and piston. Refer to [MA-12, "RECOMMENDED FLUIDS AND LUBRICANTS"](#).
2. Attach the inner shim and shim cover to the inner pad and attach the outer shim to the outer pad.
3. Apply grease to the contact surface of pad retainer with the pads, then attach the pad retainer and pads to the torque member. Make sure the upper pad retainer end is inserted through the loop on the audible wear indicator as shown.
4. Install the cylinder body to the torque member.
5. Insert a main pin bolt (on the lower side) and tighten it to specification. Refer to [BR-21, "Component"](#).
6. Inspect fluid level, then install master cylinder reservoir cap.
7. Check the brakes for drag.

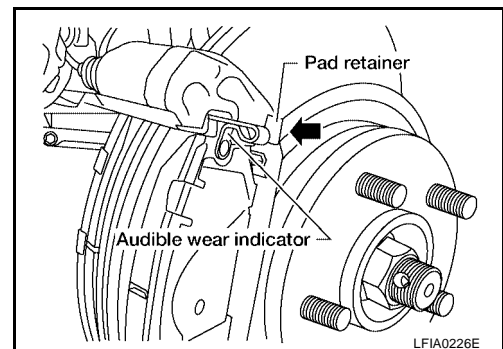

CAUTION:

Burnish the brake contact surfaces after refinishing or replacing brake rotors, after replacing pads, or if a soft pedal occurs at very low mileage. Refer to [BR-26, "Brake Burnishing Procedure"](#).

Removal and Installation of Caliper Assembly and Disc Rotor

EFS00467

REMOVAL

1. Remove master cylinder reservoir cap.
2. Connect the vinyl tube and container to the air bleeder.
3. Depress the brake pedal and drain the brake fluid gradually from the air bleeder.

FRONT DISC BRAKE

[CLZ25VD]

4. Remove connecting bolt and torque member fixing bolts, using power tool.
5. Remove the brake caliper.
6. Remove disc rotor.
7. Separate brake caliper from torque member as required.

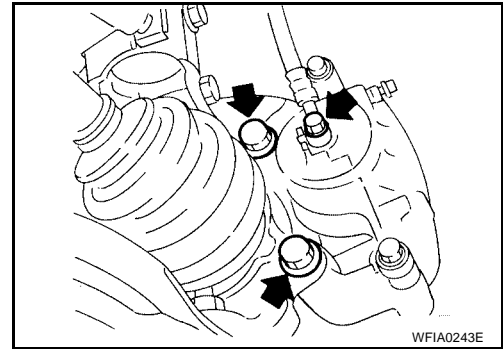

INSTALLATION

CAUTION:

- Refill with new brake fluid. Refer to [MA-12, "RECOMMENDED FLUIDS AND LUBRICANTS"](#) .
- Never reuse drained brake fluid.

1. Install disc rotor.
2. Install the brake caliper to torque member and tighten main pin bolt to specification, if required. Refer to [BR-21, "Component"](#) .

CAUTION:

When installing the cylinder body in the vehicle, wipe oil from the seating surface of the knuckle spindle washer and the mounting surface of the cylinder body.

3. Install brake cylinder body to steering knuckle and tighten torque member bolts.
4. Install brake hose to caliper and tighten connecting bolt.

CAUTION:

- The copper washer of the connecting bolt has to be replaced every time the fitting is disconnected.
- Correctly attach the brake hose to the projecting portion of the cylinder body.

5. Inspect brake fluid level, then install master cylinder reservoir cap.
6. Bleed air from brake system. Refer to [BR-9, "Bleeding Brake System"](#) .

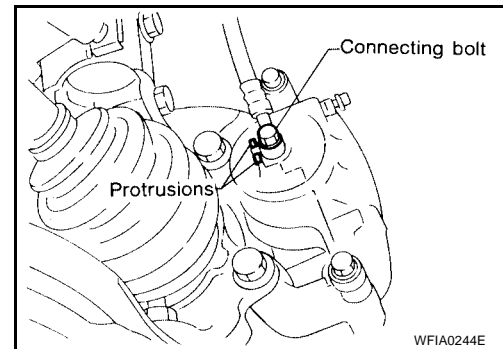

CAUTION:

Burnish the brake contact surfaces after refinishing or replacing brake rotors, after replacing pads, or if a soft pedal occurs at very low mileage. Refer to [BR-26, "Brake Burnishing Procedure"](#) .

Disassembly and Assembly of Caliper Assembly

EFS00468

1. Push out piston with piston boot using compressed air.

WARNING:

Do not place your fingers in front of piston.

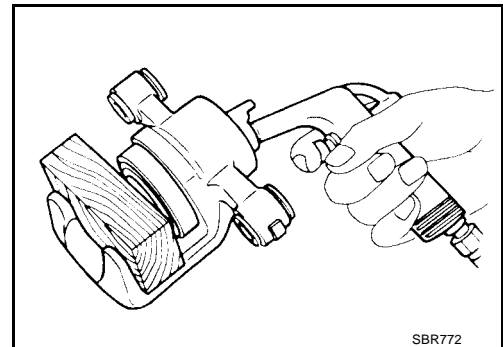

- Remove piston seal with a suitable tool.

CAUTION:

Do not scratch or score cylinder wall.

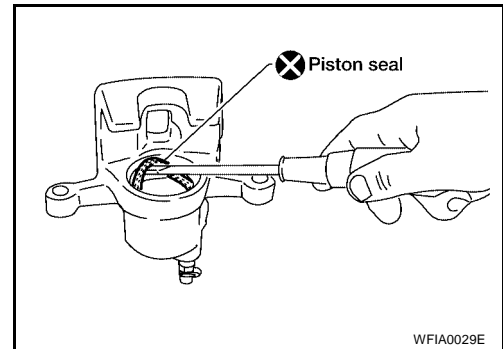

INSPECTION AFTER DISASSEMBLY

Caliper

CYLINDER BODY

CAUTION:

Use brake fluid to clean. Never use mineral oil.

- Check inside surface of cylinder for score, rust, wear, damage or presence of foreign materials. If any of the above conditions are observed, replace cylinder body.
- Minor damage from rust or foreign materials may be eliminated by polishing surface with a fine emery paper. Replace cylinder body if necessary.

TORQUE MEMBER

Check for wear, cracks or other damage. Replace if necessary.

PISTON

CAUTION:

Piston sliding surface is plated. Do not polish with emery paper even if rust or foreign materials are stuck to sliding surface.

Check piston for score, rust, wear, damage or presence of foreign materials. Replace if any of the above conditions are observed.

SLIDE PIN, PIN BOLT AND PIN BOOT

Check for wear, cracks or other damage. Replace if any of the conditions are observed.

Rotor

VISUAL INSPECTION

Check rotor for roughness, cracks or chips.

RUNOUT

- Secure rotor to wheel hub with at least two nuts (M12 x 1.25).
- Check runout using a dial indicator. Make sure that wheel bearing axial end play is within the specifications before measuring runout. Refer to [FAX-5, "FRONT WHEEL BEARING"](#).
- Change relative positions of rotor and wheel hub so that runout is minimized.

Maximum runout : 0.07 mm (0.0028 in)

- If the runout is still out of specification, turn rotor with on-car brake lathe ("MAD, DL-8700", "AMMCO 700 and 705" or equivalent).

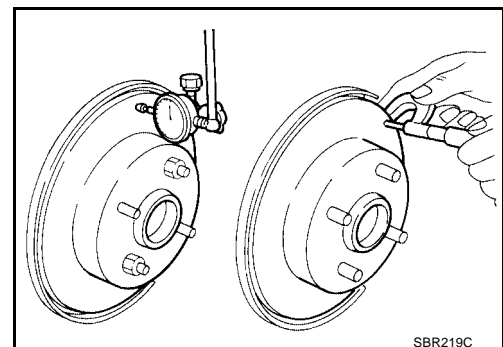

THICKNESS

Check thickness using a micrometer.

**Thickness variation : Maximum 0.015 mm
(At least 8 positions) (0.0006 in)**

If thickness variation exceeds the specification, turn rotor with on-car brake lathe.

**Rotor thickness : 22.0 mm (0.866 in)
repair limit**

ASSEMBLY

1. Apply rubber grease to new piston seal and insert seal into groove on cylinder body.

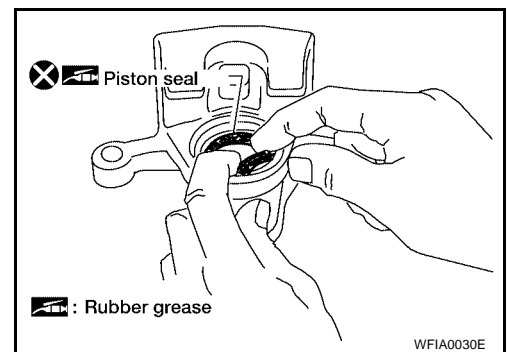
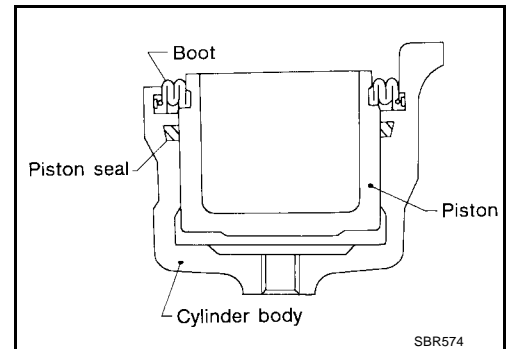

2. With piston boot fitted to piston, insert piston boot into groove on cylinder body and install piston.

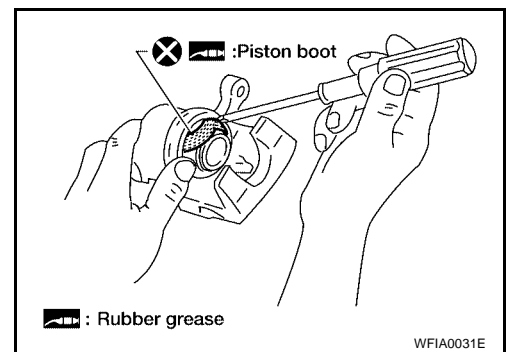

3. Make sure piston boot is properly installed.

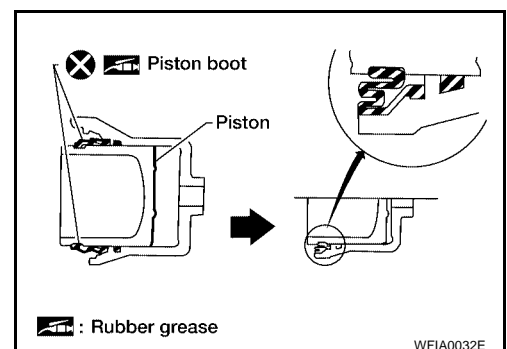

A
B
C
D
E
BR
G
H
I
J
K
L
M

Brake Burnishing Procedure

Burnish the brake contact surfaces according to the following procedure after refinishing or replacing brake rotors, after replacing pads or linings, or if a soft pedal occurs at very low mileage.

CAUTION:

Only perform this procedure under safe road and traffic conditions. Use extreme caution.

1. Drive the vehicle on a straight smooth road at 50 km/h (31 MPH).
2. Use medium brake pedal/foot effort to bring the vehicle to a complete stop from 50 km/h (31 MPH). Adjust brake pedal/foot pressure so that vehicle stopping time equals 3 to 5 seconds.
3. To cool the brake system, drive the vehicle at 50 km/h (31 MPH) for 1 minute without stopping.
4. Repeat steps 1 to 3, 10 times or more to complete the burnishing procedure.

FRONT DISC BRAKE

Component

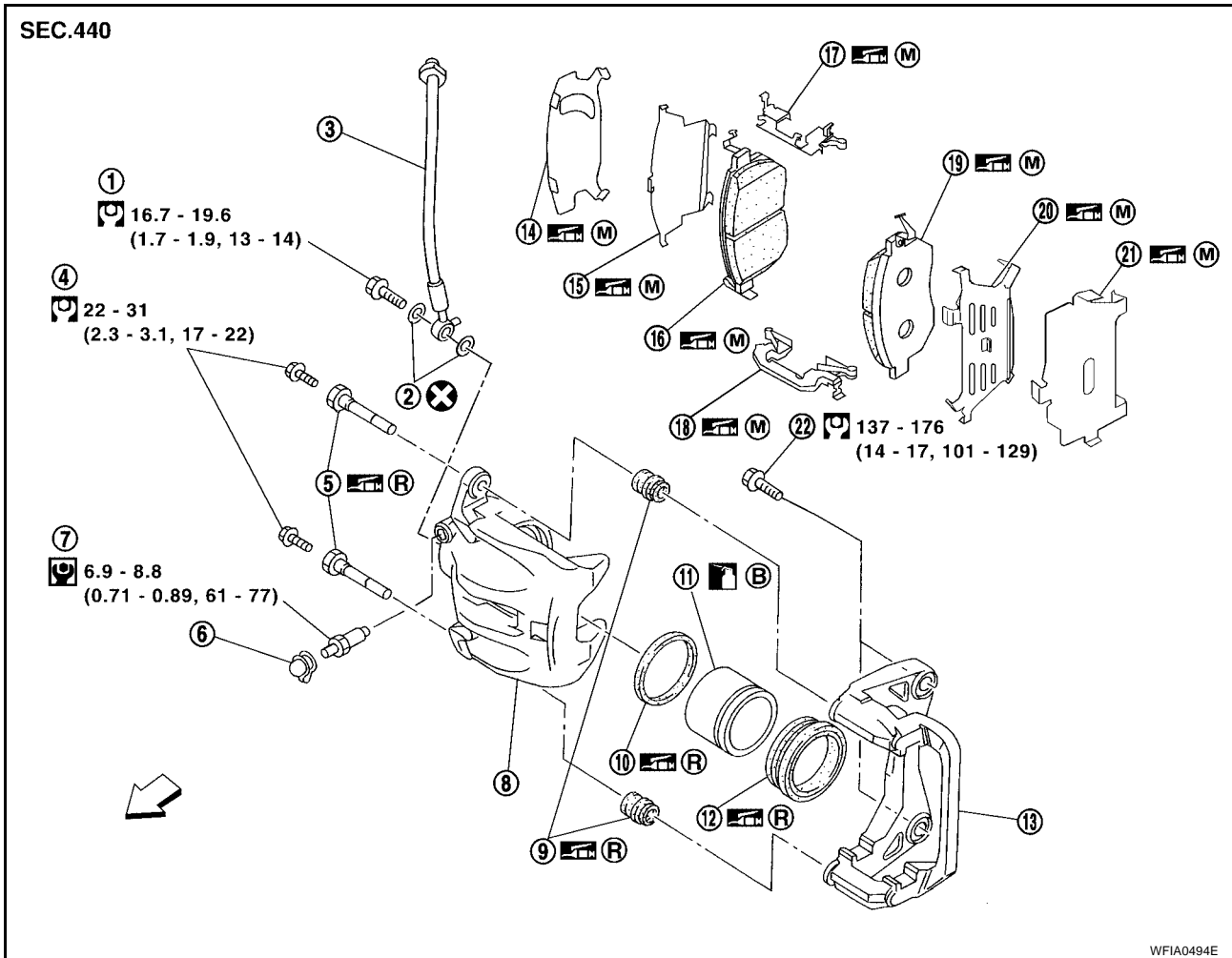

- | | | |
|-------------------------|----------------------|----------------------|
| 1. Union bolt | 2. Copper washer | 3. Brake hose |
| 4. Sliding pin bolt | 5. Sliding pin | 6. Cap |
| 7. Air bleeder | 8. Cylinder body | 9. Sliding pin boot |
| 10. Piston seal | 11. Piston | 12. Piston boot |
| 13. Torque member | 14. Inner shim cover | 15. Inner shim |
| 16. Inner pad | 17. Pad retainer | 18. Pad retainer |
| 19. Outer pad | 20. Outer shim | 21. Outer shim cover |
| 22. Torque member bolts | ← Front | |

CAUTION:

- Clean dust on caliper and brake pad with a vacuum dust collector. Do not blow with compressed air.
- While the brake pad and cylinder body are separated, the piston may suddenly jump out, so do not depress the brake pedal.
- It is not necessary to remove bolts on torque member and brake hose except for disassembly or replacement of the caliper assembly. In this case, hang cylinder body with a wire so that brake hose is not under tension.
- Do not damage piston boot.
- If any shim is subject to serious corrosion, replace it with a new one.
- Always replace shims and shim covers as a set when replacing brake pads.
- Keep the rotor clean of brake fluid.

- Burnish the brake contact surfaces when refinishing or replacing brake rotors, after replacing pads or linings, or if a soft pedal occurs at very low mileage. Refer to [BR-32, "Brake Burnishing"](#) .

On-board Inspection PAD WEAR INSPECTION

EFS004MA

- Inspect the thickness of the pad through the cylinder body inspection hole. Use a scale for inspection if necessary.

Standard pad thickness : 9.5 mm (0.374 in)
Pad wear limit : 2.0 mm (0.079 in)

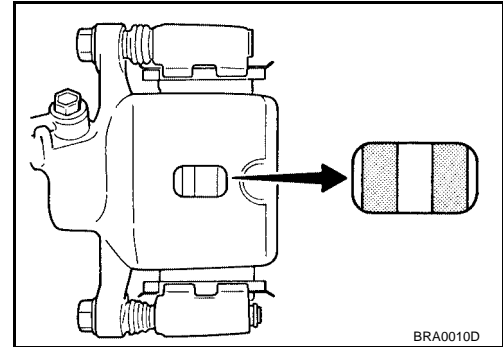

Removal and Installation of Brake Pad REMOVAL

EFS004MB

1. Remove tires from vehicle using power tool.
2. Remove lower sliding pin bolt.
3. Hang the cylinder body with a wire then remove the pads, pad retainers, and shims from the torque member.

CAUTION:

When removing the pad retainer from the torque member, lift the pad retainer in the direction shown by the arrow (shown in the figure) so as not to deform it.

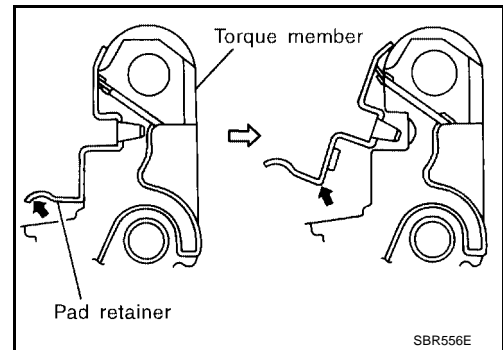

INSTALLATION

1. Apply Molykote M-77 grease between pad plate and shim, shim and shim cover, and shim cover and piston. Refer to [MA-12, "RECOMMENDED FLUIDS AND LUBRICANTS"](#) .
2. Attach the pad retainer and pad to the torque member.

CAUTION:

- When attaching the pad retainer, attach it firmly so that it does not float up higher than the torque member, as shown in the figure.

3. Push the piston in so that the pad is firmly attached and attach the cylinder body to the torque member.

NOTE:

Using a disc brake piston tool (commercial service tool), makes it easier to push in the piston.

CAUTION:

- By pushing in the piston, the brake fluid returns to the master cylinder reservoir tank. Watch the level of the surface of the reservoir tank.

4. Install the sliding pin bolt and tighten to specification. Refer to [BR-27, "Component"](#) .
5. Check brake for drag.
6. Attach the tires to the vehicle. Refer to [WT-7, "Rotation"](#) .

CAUTION:

Burnish the brake contact surfaces when refinishing or replacing brake rotors, after replacing pads or linings, or if a soft pedal occurs at very low mileage. Refer to [BR-32, "Brake Burnishing"](#) .

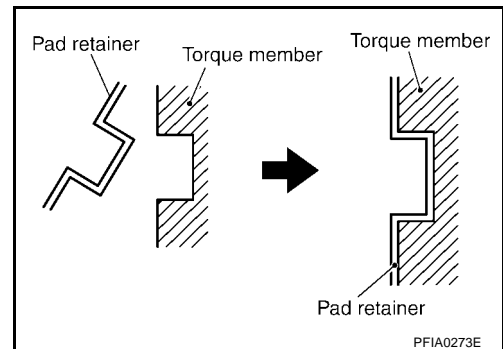

Removal and Installation of Caliper Assembly and Disc Rotor**REMOVAL**

1. Remove tires from vehicle with power tool.
2. Drain brake fluid. Refer to [BR-9, "Changing Brake Fluid"](#).
3. Remove union bolt and torque member bolts using power tool, then remove caliper assembly.
4. Remove disc rotor.
 - Prior to removing disc rotor, make alignment mark using a marker between the hub and disc rotor.

INSTALLATION**CAUTION:**

- Refill with new brake fluid. Refer to [MA-12, "RECOMMENDED FLUIDS AND LUBRICANTS"](#).
- Never reuse drained brake fluid.

1. Install disc rotor.
 - Align marks made during removal on the hub and disc rotor.
2. Install caliper assembly to the vehicle, and tighten torque member bolts to the specification. Refer to [BR-27, "Component"](#).

CAUTION:

When attaching the caliper assembly to the vehicle, wipe any oil off the knuckle spindle washers and caliper assembly attachment surfaces.

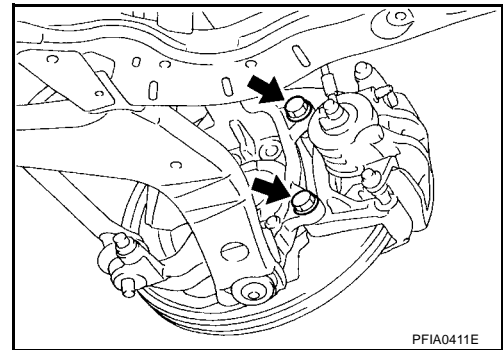

3. Install brake hose to the caliper assembly, and tighten union bolt to the specification. Refer to [BR-27, "Component"](#).

CAUTION:

- Do not reuse the copper washer for union bolts.
- Attach the brake hose to the protrusion on the caliper assembly attachment part.

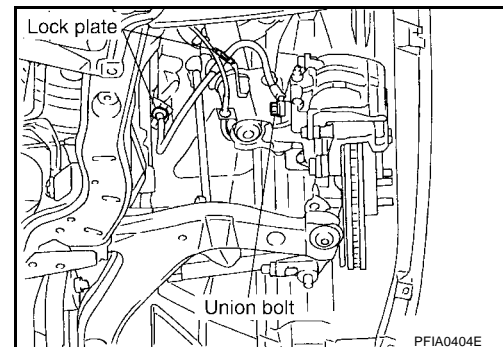

4. Refill new brake fluid and bleed air. Refer to [BR-9, "Bleeding Brake System"](#).
5. Attach the tires to the vehicle. Refer to [WT-7, "Rotation"](#).

CAUTION:

Burnish the brake contact surfaces when refinishing or replacing brake rotors, after replacing pads or linings, or if a soft pedal occurs at very low mileage. Refer to [BR-32, "Brake Burnishing"](#).

Disassembly and Assembly of Caliper Assembly DISASSEMBLY

1. Remove the sliding pin bolt, and then remove the pad, shim, shim cover, and pad retainer from the torque member.

CAUTION:

When removing the pad retainer from the torque member, lift it in the direction indicated by the arrow in the figure so that it does not deform.

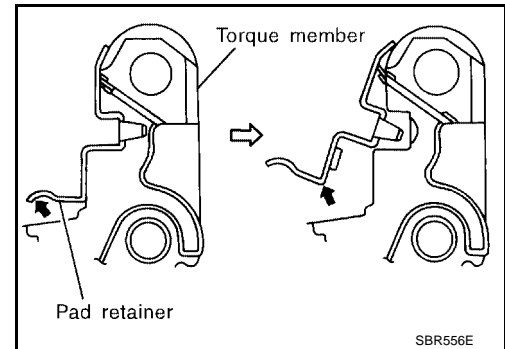

2. Remove sliding pins and sliding pin boots from torque member.
3. Place a wooden block as shown, and blow air from union bolt mounting hole to remove pistons and piston boots.

CAUTION:

Do not get your fingers caught in the piston.

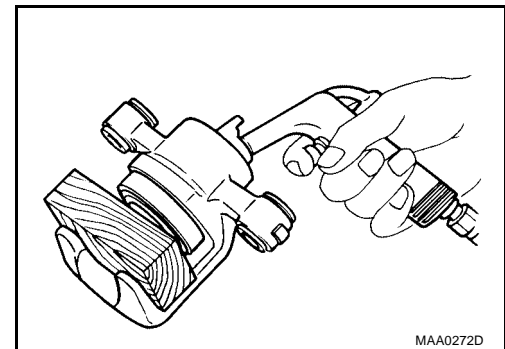

4. Remove the piston seal from the cylinder body using a screwdriver or suitable tool.

CAUTION:

Be careful not to damage cylinder inner wall.

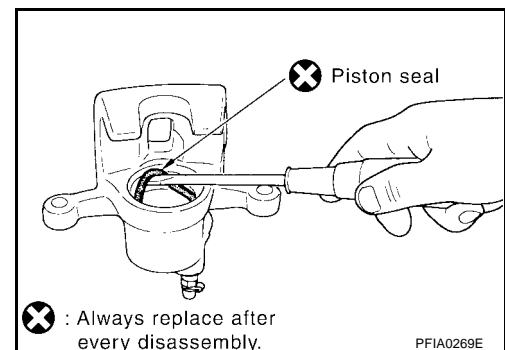

CALIPER INSPECTION

Cylinder Body

CAUTION:

- Use new brake fluid to clean. Never use mineral oils such as gasoline or kerosene.
- Check for corrosion, wear, or damage to the cylinder inner wall, and replace the caliper if there are any non-standard conditions.
- Minor flaws caused by corrosion or a foreign material can be removed by polishing the surface with a fine sandpaper. Replace the cylinder body, if necessary.

Torque Member

Check for wear, cracks, and damage. If damage or deformation is present, replace the affected part.

Piston

CAUTION:

- Since the piston surface is plated, do not repair using sandpaper.
- Check piston surface for corrosion, wear, and damage. If any non-standard condition is detected, replace applicable part.

Sliding Pins, Sliding Pin Bolts, and Sliding Pin Boots

Check sliding pins, sliding pin bolts, and sliding pin boot for wear, damage, and cracks. If damage or deformation is present, replace the affected part.

ASSEMBLY

CAUTION:

Do not use Nissan Rubber Grease (KRE00 00010 or KRE00 00010 01) when assembling.

1. Apply rubber grease to the piston seal and attach to cylinder body.

CAUTION:

Do not reuse the piston seals.

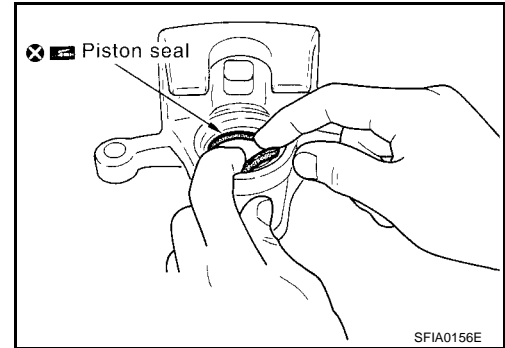

2. Apply brake fluid or rubber grease to the piston boot, place it on the piston, and firmly insert the piston boot cylinder-side lip into the cylinder body groove.

CAUTION:

Do not reuse the piston boot.

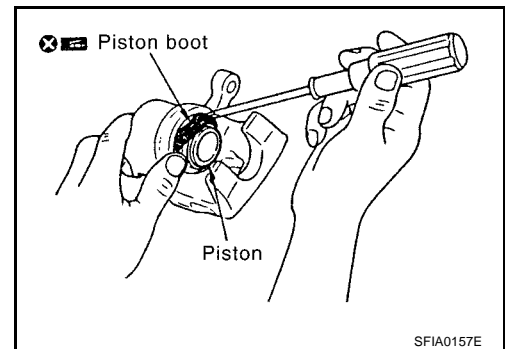

3. Apply brake fluid or rubber grease to the piston, insert into the cylinder body by hand and firmly attach the piston boot piston-side lip into the piston groove.

CAUTION:

Press the piston evenly and vary the pressing point to prevent cylinder inner wall from being rubbed.

4. Install sliding pins and sliding pin boots to torque member.

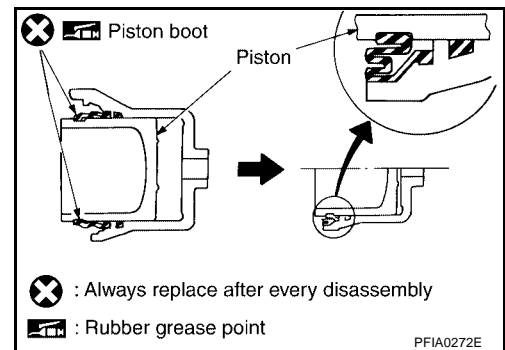

5. Attach the inner shim and shim cover to the inner pad and the outer shim to the outer pad.
6. Install cylinder body. Tighten sliding pin bolt to the specified torque.

DISC ROTOR INSPECTION

Visual Inspection

Check surface of the disc rotor for uneven wear, cracks, and serious damage. If any non-standard condition is detected, replace applicable part.

Runout Inspection

1. Using wheel nuts, fix disc rotor to the wheel hub in 2 or more positions.

- Inspect runout using a dial gauge.

Standard value
 (measured at 10 mm (0.39 in) inside the disc edge)
Runout limit : 0.07 mm (0.0028 in)
 (with it attached to the vehicle) or less

CAUTION:

Before measuring, make sure the axle endplay is 0 mm (0 in). Refer to [FAX-5, "FRONT WHEEL BEARING"](#).

- If runout is outside the limit, find the minimum runout point by shifting mounting positions of the disc rotor and wheel hub by one hole.

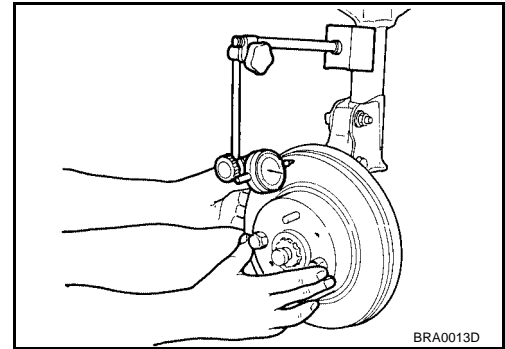

BRA0013D

Thickness Inspection

Using a micrometer, check thickness of the disc rotor. If thickness does not meet specification, replace disc rotor.

Standard thickness : 28 mm (1.10 in)
Minimum thickness : 26 mm (1.02 in)
Maximum uneven wear : 0.015 mm (0.0006 in) or
 (measured at 8 positions) less

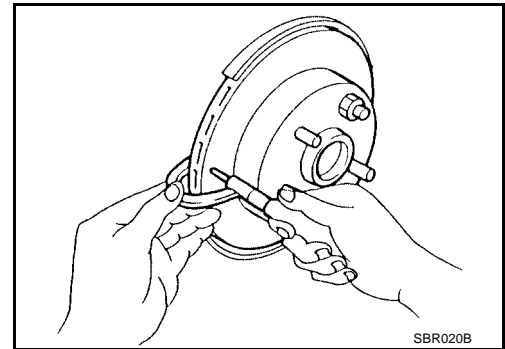

SBR020B

Brake Burnishing

Burnish the brake contact surface according to the following procedure after refinishing or replacing rotors, after replacing pads, or if a soft pedal occurs at very low mileage.

CAUTION:

Only perform this procedure under safe road and traffic conditions. Use extreme caution.

- Drive the vehicle on a straight smooth road at 50 km/h (31 MPH).
- Use medium brake pedal /foot effort to bring the vehicle to a complete stop from 50 km/h (31 MPH). Adjust brake pedal /foot pressure such that vehicle stopping time equals 3 to 5 seconds.
- To cool the brake system, drive the vehicle at 50 km/h (31 MPH) for 1 minute without stopping.
- Repeat steps 1 to 3, 10 times or more to complete the burnishing procedure.

EFS004ME

REAR DISC BRAKE

PFP:44000

EFS0046A

REAR DISC BRAKE

Component

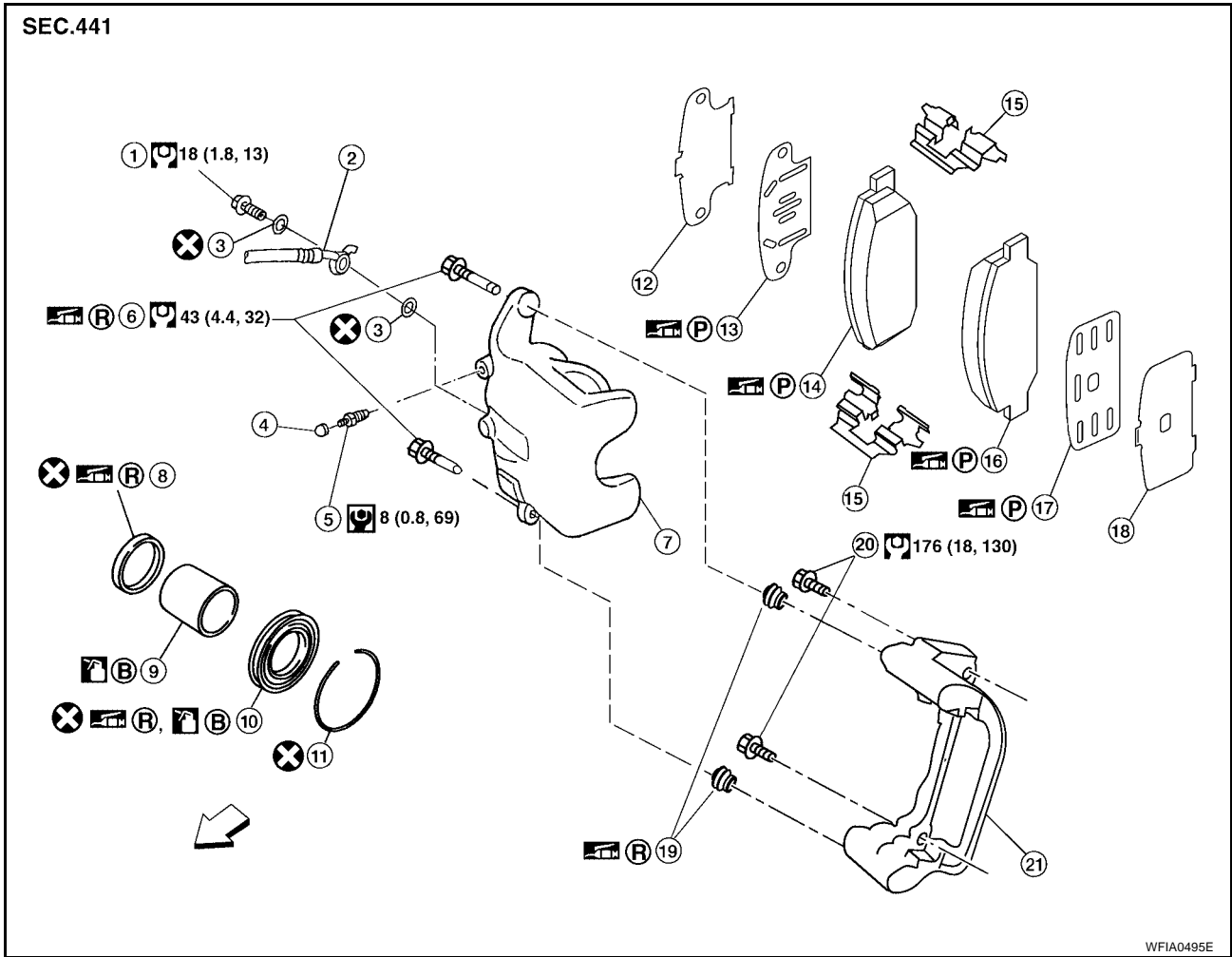

A
B
C
D
E
BR
G
H
I
J
K
L
M

- | | | |
|----------------------|-------------------------|----------------------|
| 1. Connecting bolt | 2. Brake hose | 3. Copper washer |
| 4. Cap | 5. Air bleeder | 6. Sliding pin |
| 7. Cylinder body | 8. Piston seal | 9. Piston |
| 10. Piston boot | 11. Retaining ring | 12. Inner shim cover |
| 13. Inner shim | 14. Inner pad | 15. Pad retainer |
| 16. Outer pad | 17. Outer shim | 18. Outer shim cover |
| 19. Sliding pin boot | 20. Torque member bolts | 21. Torque member |
- ← Front

WARNING:

Clean dust on caliper and brake pad with a vacuum dust collector. Do not blow with compressed air.

CAUTION:

- While removing cylinder body, never depress the brake pedal because the piston will pop out.
- It is not necessary to remove bolts on torque member and brake hose except for disassembly or replacement of the cylinder body. In this case, hang cylinder body with a wire so that brake hose is not under tension.
- Do not damage piston boot.
- Always replace shims and shim covers as a set when replacing brake pads.
- Keep the rotor clean of brake fluid.
- Burnish the brake contact surfaces when refinishing or replacing brake rotors, after replacing pads or linings, or if a soft pedal occurs at very low mileage. Refer to [BR-39, "Brake Burnishing"](#).

REAR DISC BRAKE

EFS0046B

On-Vehicle Service PAD WEAR INSPECTION

- Inspect the thickness of the pad through the cylinder body inspection hole. Use a scale for inspection if necessary.

Standard pad thickness : 8.0 mm (0.315 in)

Pad wear limit : 1.5 mm (0.059 in)

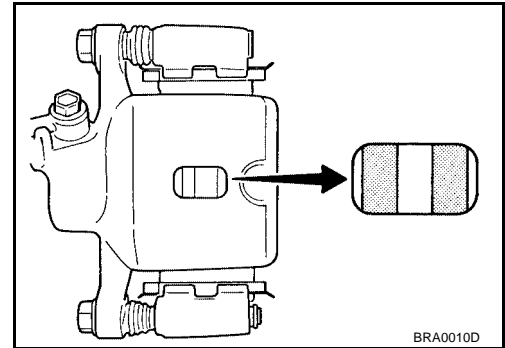

REMOVAL AND INSTALLATION OF BRAKE PAD

Removal

- Remove master cylinder reservoir cap.
- Remove tires from vehicle with power tool.
- Remove bottom sliding pin bolt.
- Hang cylinder body with a wire, and remove pads, pad retainers, shims from torque member.

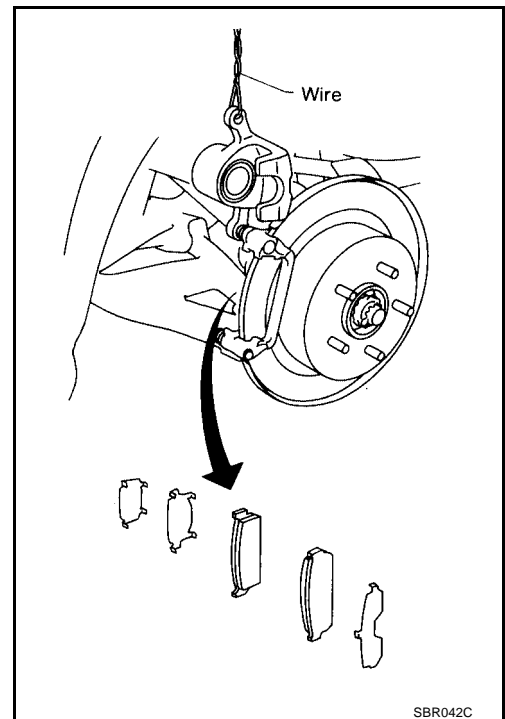

Installation

- Apply PBC (Poly Butyl Cuprysil) grease or silicone-based grease between pad plate and shim, shim and shim cover, and shim cover and piston. Refer to [MA-12, "RECOMMENDED FLUIDS AND LUBRICANTS"](#)
- Attach the inner shim and shim cover to the inner pad, and the outer shim and outer shim cover to the outer pad.
- Attach the pad retainer and pad to the torque member.
- Push the piston in so that the pad is firmly attached and attach the cylinder body to the torque member.

NOTE:

Using a disc brake piston tool (commercial service tool), makes it easier to push in the piston.

CAUTION:

By pushing in the piston, the brake fluid returns to the master cylinder reservoir tank. Watch the level of the surface of the reservoir tank.

- Install the sliding pin bolt and tighten to the specified torque.

REAR DISC BRAKE

Sliding pin bolt : 38 – 48 N·m (3.9 – 4.8 kg-m, 25 – 35 ft-lb)

6. Inspect brake fluid level, then install master cylinder reservoir cap.
7. Check brake for drag.
8. Attach the tires to the vehicle. Refer to [WT-7, "Rotation"](#) .

CAUTION:

Burnish the brake contact surfaces when refinishing or replacing brake rotors, after replacing pads or linings, or if a soft pedal occurs at very low mileage. Refer to [BR-39, "Brake Burnishing"](#) .

Removal and Installation

EFS0046C

REMOVAL

1. Remove master cylinder reservoir cap.
2. Remove tires from vehicle using power tool.
3. Drain brake fluid. Refer to [BR-9, "Bleeding Brake System"](#) .
4. Remove connecting bolt and torque member bolts using power tool, and remove cylinder body.

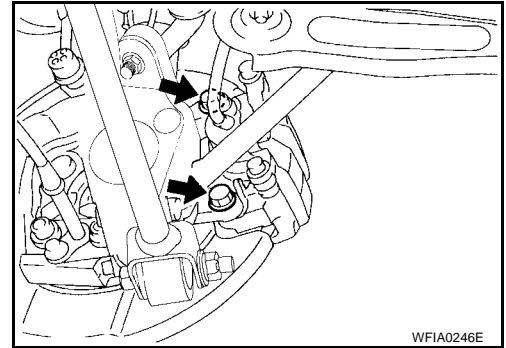

5. Remove caliper and disc rotor. If the disc rotor cannot be removed, remove as follows:

- Make sure parking brake lever is completely disengaged.
- Hold down the disc rotor with the wheel nut and remove the adjuster hole plug.
- Insert a flat-bladed screwdriver through the plug opening and rotate the star wheel on the adjuster assembly in the direction shown to loosen and retract the brake shoes.
- Prior to removing disc rotor, make alignment mark using a marker between the hub and disc rotor.
- Remove wheel nut and rotor.

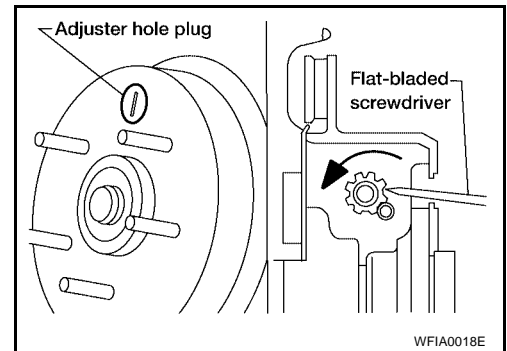

INSTALLATION

CAUTION:

- Refill with new brake fluid. Refer to [MA-12, "RECOMMENDED FLUIDS AND LUBRICANTS"](#) .
- Never reuse drained brake fluid.

1. Install disc rotor.
 - Align marks made during removal on the hub and disc rotor.
2. Install cylinder body to the vehicle, and tighten torque member bolts to the specified torque.

Torque member bolts : 157 –196 N·m (16 –19 kg-m, 116 – 144 ft-lb)

CAUTION:

Before installing cylinder body to the vehicle, wipe off oil and grease on washer seats on axle assembly and mounting surface of cylinder body.

3. Install brake hose to cylinder body and tighten connecting bolt to the specified torque.

Connecting bolt : 16.7 – 19.6 N·m (1.7 – 1.9 kg-m, 13 – 14 ft-lb)

CAUTION:

- Do not reuse the copper washer for connecting bolts.

REAR DISC BRAKE

- **Securely attach brake hose to protrusion on cylinder body.**

4. Add new brake fluid and bleed air. Refer to [BR-9, "Bleeding Brake System"](#).
5. Install master cylinder reservoir cap.
6. Adjust the parking brake. Refer to [PB-5, "Adjustment"](#).
7. Attach the tires to the vehicle. Refer to [WT-7, "Rotation"](#).

CAUTION:

Burnish the brake contact surfaces when refinishing or replacing brake rotors, after replacing pads, or if a soft pedal occurs at very low mileage. Refer to [BR-39, "Brake Burnishing"](#).

Disassembly and Assembly

DISASSEMBLY

EFS0046D

1. Remove the sliding pin bolt, and then remove the pad, shim, shim cover, and pad retainer from the torque member and cylinder.
2. Remove sliding pin boot from torque member.
3. Remove the retaining ring from the cylinder body using a screwdriver or suitable tool, as shown.

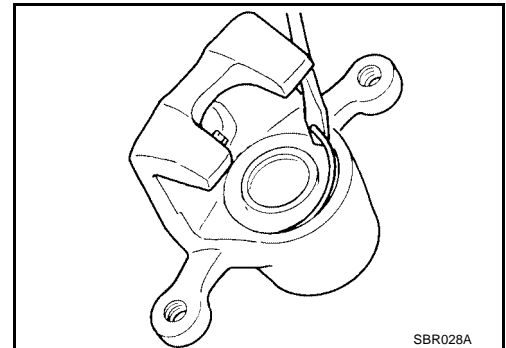

4. Place a wooden block as shown, and blow air from connecting bolt mounting hole to remove pistons and piston boots.

WARNING:

Do not place your finger in front of piston.

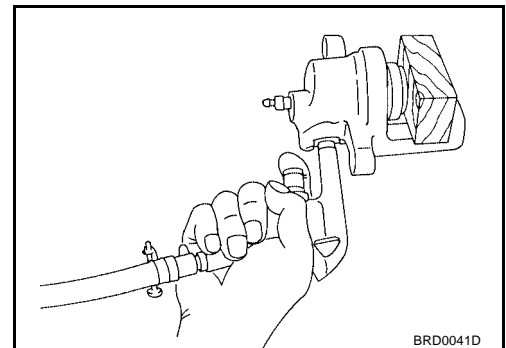

5. Remove piston seals from cylinder body using a screwdriver or suitable tool, as shown.

CAUTION:

Be careful not to damage cylinder inner wall.

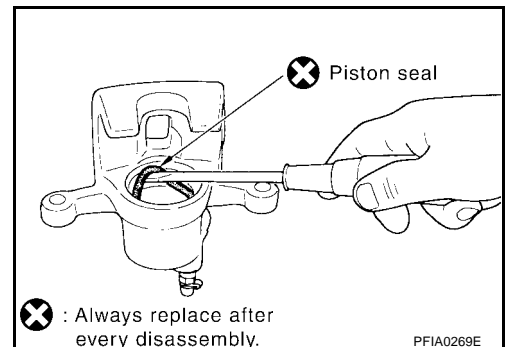

REAR DISC BRAKE

CALIPER INSPECTION

Cylinder Body

CAUTION:

- Use new brake fluid to clean. Never use mineral oils such as gasoline or kerosene.
- Check inner wall of cylinder for corrosion, wear, and damage. If any non-standard condition is detected, replace cylinder body.
- Minor flaws caused by corrosion or a foreign material can be removed by polishing the surface with a fine sandpaper. Replace the cylinder body, if necessary.

Torque Member

Check for wear, cracks, and damage. If damage or deformation is present, replace the affected part.

Piston

CAUTION:

Since the piston surface is plated, do not repair using sandpaper.

Check piston surface for corrosion, wear, and damage. If any non-standard condition is detected, replace applicable part.

Sliding Pin Bolts and Sliding Pin Boots

Check that there is no wear, damage, or cracks in the sliding pin bolts and sliding pin boots, and if there are, replace them.

ASSEMBLY

CAUTION:

Do not use Nissan Rubber Grease (KRE00 00010 or KRE00 00010 01) when assembling.

1. Apply a rubber grease to the piston seal and attach to cylinder body.

CAUTION:

Do not reuse the piston seals.

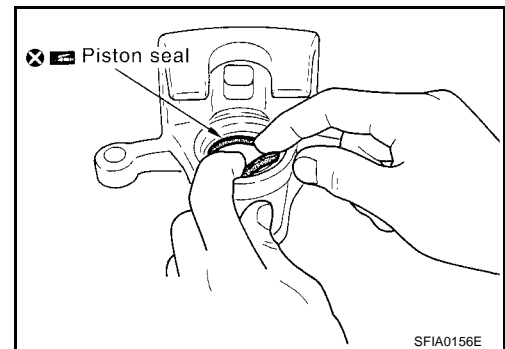

2. Apply brake fluid or rubber grease to the piston boot, place it on the piston, and firmly insert the piston boot cylinder-side lip into the cylinder body groove.

CAUTION:

Do not reuse the piston boot.

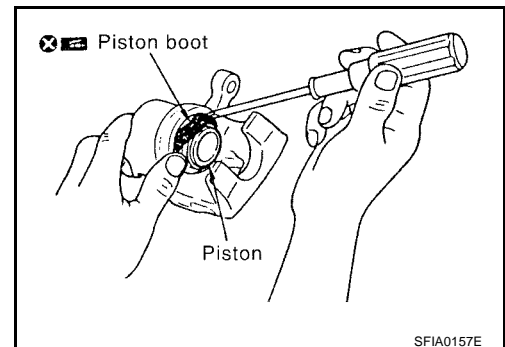

REAR DISC BRAKE

3. Apply a brake fluid to the piston, insert into the cylinder body by hand and firmly attach the piston boot piston-side lip into the piston boot.

CAUTION:

Press the piston evenly and vary the pressing point to prevent cylinder inner wall from being rubbed.

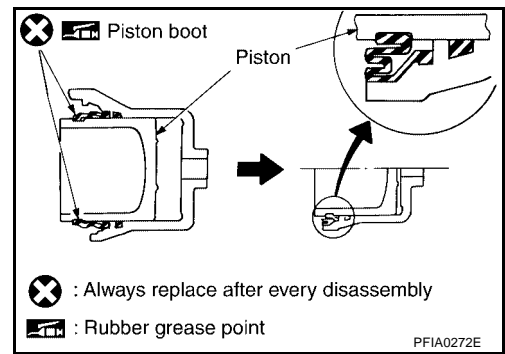

4. Fix piston boot with retaining ring.

CAUTION:

- Make sure the boot is firmly in the cylinder body groove.
- Do not reuse the retaining ring.

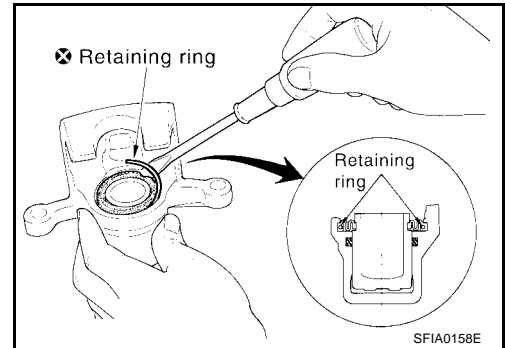

5. Attach the sliding pin bolt and sliding pin boot to the torque member.
6. Apply PBC (Poly Butyl Cuprysil) grease or silicone-based grease to the rear of the pad and to both sides of the shim, and attach the inner shim and shim cover to the inner pad, and the outer shim and outer shim cover to the outer pad.
7. Attach the pad retainer and pad to the torque member.

CAUTION:

When attaching the pad retainer, attach it firmly so that it does not float up higher than the torque member, as shown in the figure.

8. After assembling shims and shim covers to pad, install it to the torque member.
9. Install cylinder body. Tighten sliding pin bolts to the specified torque.

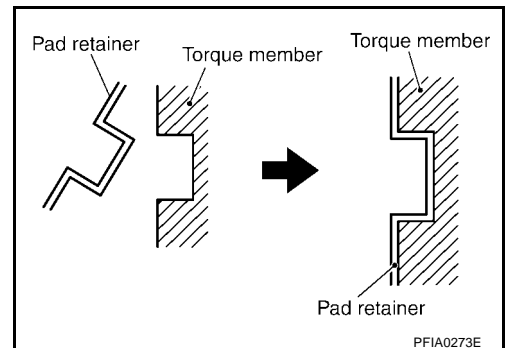

DISC ROTOR INSPECTION

Visual Inspection

Check surface of the disc rotor for uneven wear, cracks, and serious damage. If any non-standard condition is detected, replace applicable part.

Runout Inspection

1. Using wheel nuts, fix disc rotor to the wheel hub in two or more positions.
2. Inspect runout using a dial gauge.

Measurement position : At a point 10 mm (0.39 in) from outer edge of the disc.

Runout limit (with it attached to the vehicle) : 0.07 mm (0.0028 in) or less

CAUTION:

Before measuring, make sure the axle endplay is 0 mm (0 in).

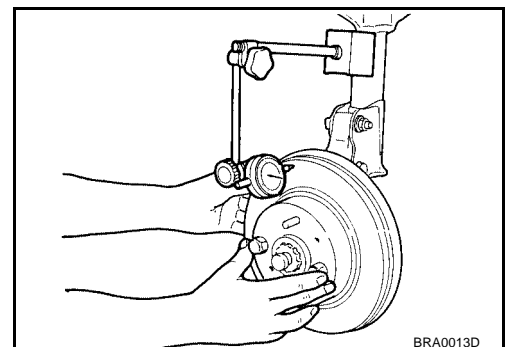

REAR DISC BRAKE

3. If runout is outside the limit, find the minimum runout point by shifting mounting positions of the disc rotor and wheel hub by one hole.

Thickness Inspection

Using a micrometer, check thickness of the disc rotor. If thickness is not within specification, replace disc rotor.

Standard thickness	: 9.0 mm (0.350 in)
Minimum thickness	: 8.0 mm (0.310 in)
Maximum uneven wear (measured at 8 positions)	: 0.015 mm (0.0006 in) or less

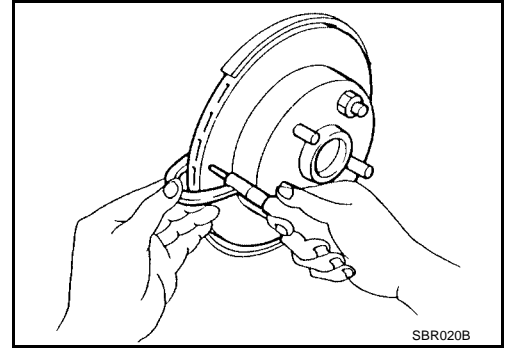

EFS0046E

Brake Burnishing

Burnish the brake contact surface according to the following procedure after refinishing or replacing rotors, after replacing pads, or if a soft pedal occurs at very low mileage.

CAUTION:

Only perform this procedure under safe road and traffic conditions. Use extreme caution.

1. Drive the vehicle on a straight smooth road at 50 km/h (31 MPH).
2. Use medium brake pedal /foot effort to bring the vehicle to a complete stop from 50 km/h (31 MPH). Adjust brake pedal /foot pressure such that vehicle stopping time equals 3 to 5 seconds.
3. To cool the brake system, drive the vehicle at 50 km/h (31 MPH) for 1 minute without stopping.
4. Repeat steps 1 to 3, 10 times or more to complete the burnishing procedure.

DUAL PROPORTIONING VALVE

DUAL PROPORTIONING VALVE

PF:46400

Inspection

EFS0046F

CAUTION:

- Carefully monitor brake fluid level at master cylinder.
 - Use new brake fluid. Refer to [MA-12, "RECOMMENDED FLUIDS AND LUBRICANTS"](#) .
 - Be careful not to splash brake fluid on painted areas; it may cause paint damage. If brake fluid is splashed on paint areas, wash it away with water immediately.
1. Connect Tool to air bleeders of front and rear brakes on either LH and RH side.

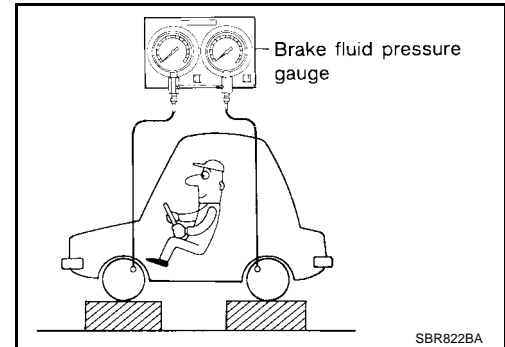

2. Bleed air from the Tool.
3. Check fluid pressure by depressing brake pedal.

**Applied pressure : 7,355 kPa (75 kg/cm², 1,067 psi)
(Front brake)**

**Output pressure : 5,100 - 5,492 kPa (52 - 56 kg/cm²,
(Rear brake) 739 - 796 psi)**

If output pressure is out of specification, replace dual proportioning valve.

4. Bleed air after disconnecting the Tool. Refer to [BR-9, "Bleeding Brake System"](#) .

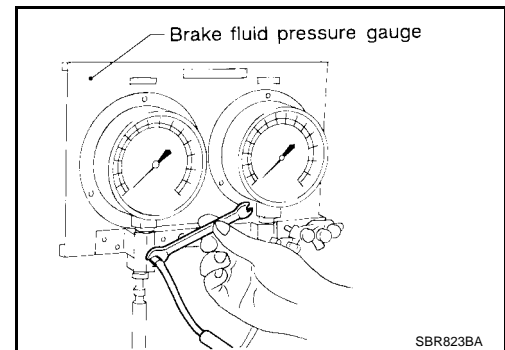

SERVICE DATA AND SPECIFICATIONS (SDS)

SERVICE DATA AND SPECIFICATIONS (SDS)

PFP:00030

General Specifications

EFS0046G

Unit: mm (in)

Front brake	Brake model		CLZ25VD disc brake	CLZ25VE disc brake
	Cylinder bore diameter		57.2 (2.25)	57.2 (2.25)
	Pad Length × width × thickness		125.6 × 46 × 11 (4.94 × 1.81 × 0.43)	111.0 × 62.5 × 9.5 (4.37 × 2.46 × 0.37)
	Rotor outer diameter × thickness		297 × 24 (11.7 × 0.94)	320 × 28 (12.6 × 1.10)
Rear brake	Brake model		AD9A disc brake	
	Cylinder bore diameter		34.9 (1.3740)	
	Pad Length × width × thickness		89.1 × 39.5 × 10 (3.508 × 1.555 × 0.31)	
	Rotor outer diameter × thickness		292 × 9 (11.5 × 0.35)	
Master cylinder	Cylinder bore diameter		23.81 (15/16)	
Control valve	Screw in type		30 × 0.4 (1.18 × 0.02)	
Brake booster	Booster model		M215T	
	Diaphragm diameter	Primary	230 (9.06)	
		Secondary	205 (8.07)	
Recommended brake fluid			Refer to MA-12. "RECOMMENDED FLUIDS AND LUBRICANTS"	

Disc Brake

EFS004M7

Unit: mm (in)

Brake model		CLZ25VD	CLZ25VE	AD9A
Pad wear limit	Minimum thickness	2.0 (0.079)	2.0 (0.079)	1.5 (0.059)
	Maximum runout	0.07 (0.0028)	0.07 (0.0028)	0.07 (0.0028)
Rotor repair limit	Minimum thickness	22.0 (0.866)	26.0 (1.02)	8.0 (0.31)
	Maximum thickness variation (At least 8 positions)	0.015 (0.0006)		

SERVICE DATA AND SPECIFICATIONS (SDS)

Brake Pedal

EFS0046I

Unit: mm (in)

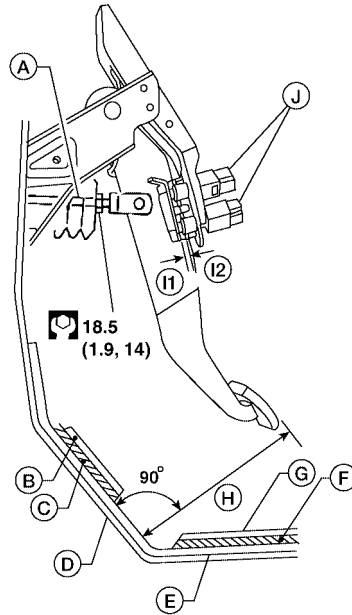

WFIA0423E

Free height "H"	M/T	164.1 - 174.1 (6.46 - 6.85)
	A/T	173.1 - 183.1 (6.81 - 7.21)
Pedal height (with engine running, brake pedal force 490 N {50 kg-f, 110 lb-f}) "H"	M/T	More than 84 (3.31)
	A/T	More than 90.3 (3.55)
Clearance "I1 or I2" between pedal stopper and threaded end of stop lamp switch or ASCD switch		0.74 - 1.96 (0.0291 - 0.0772)
Pedal play		3 - 11 (0.12 - 0.43)

*: Measured from surface of dash reinforcement panel to surface of pedal pad

A: Input rod

B: Floor carpet

C: Dash Insulator

D: Floor Panel

E: Dash reinforcement panel

F: Dash insulator

G: Floor carpet

I1, I2: Gap

J: Stop lamp switch and ASCD switch

Control Valve

EFS0046J

Unit: kPa (kg/cm², psi)

Applied pressure (front)	7,355 (75, 1,067)
Output pressure (rear)	5,100 - 5,492 (52 - 56, 739 - 796)

Brake Booster

EFS0046K

Unit: mm (in)

Output rod length	10.275 - 10.525 (0.4045 - 0.4144)
Clevis length	130 (5.12)