

SECTION **BCS**

BODY CONTROL SYSTEM

A
B
C
D
E
F
G
H
I
J
L
M

CONTENTS

<p>PRECAUTIONS 2</p> <p style="padding-left: 20px;">Precautions for Supplemental Restraint System (SRS) "AIR BAG" and "SEAT BELT PRE-TENSIONER" 2</p> <p>BCM (BODY CONTROL MODULE) 3</p> <p style="padding-left: 20px;">System Description 3</p> <p style="padding-left: 40px;">BCM FUNCTION 3</p> <p style="padding-left: 40px;">COMBINATION SWITCH READING FUNCTION 3</p> <p style="padding-left: 20px;">CAN COMMUNICATION CONTROL 5</p> <p style="padding-left: 20px;">BCM STATUS CONTROL 5</p> <p style="padding-left: 20px;">SYSTEMS CONTROLLED BY BCM DIRECTLY.... 6</p> <p style="padding-left: 20px;">SYSTEMS CONTROLLED BY BCM AND IPDM E/R 6</p> <p style="padding-left: 20px;">MAJOR COMPONENTS AND CONTROL SYSTEM 6</p>	<p>CAN Communication System Description 7</p> <p style="padding-left: 20px;">FOR TCS MODELS 7</p> <p style="padding-left: 20px;">FOR A/T MODELS 8</p> <p style="padding-left: 20px;">FOR M/T MODELS 10</p> <p style="padding-left: 20px;">Schematic 12</p> <p>CONSULT-II 14</p> <p style="padding-left: 20px;">CONSULT-II INSPECTION PROCEDURE 14</p> <p style="padding-left: 40px;">ITEMS OF EACH PART 14</p> <p>CAN Communication Inspection Using CONSULT-II (Self-Diagnosis) 15</p> <p>Combination Switch Inspection According to Self-Diagnostic Results 16</p> <p>Malfunctioning Operation of Lamps and Wipers 19</p> <p>Inspection of BCM Power Supply and Ground Circuit 21</p>
---	--

BCS

PRECAUTIONS

PRECAUTIONS

PF0:00001

Precautions for Supplemental Restraint System (SRS) “AIR BAG” and “SEAT BELT PRE-TENSIONER”

EKS002J7

The Supplemental Restraint System such as “AIR BAG” and “SEAT BELT PRE-TENSIONER”, used along with a front seat belt, helps to reduce the risk or severity of injury to the driver and front passenger for certain types of collision. Information necessary to service the system safely is included in the SRS and SB section of this Service Manual.

WARNING:

- To avoid rendering the SRS inoperative, which could increase the risk of personal injury or death in the event of a collision which would result in air bag inflation, all maintenance must be performed by an authorized NISSAN/INFINITI dealer.
- Improper maintenance, including incorrect removal and installation of the SRS, can lead to personal injury caused by unintentional activation of the system. For removal of Spiral Cable and Air Bag Module, see the SRS section.
- Do not use electrical test equipment on any circuit related to the SRS unless instructed to in this Service Manual. SRS wiring harnesses can be identified by yellow and/or orange harness connectors.

BCM (BODY CONTROL MODULE)

System Description

- BCM (Body Control Module) controls the operation of various electrical units installed on the vehicle.

BCM FUNCTION

BCM has a combination switch reading function for reading the operation of combination switches (light, wiper washer, turn signal) in addition to the function for controlling the operation of various electrical components. Also, it functions as an interface that receives signals from the A/C control unit (with manual A/C), A/C auto amplifier (with auto A/C), and sends signals to ECM using CAN communication.

COMBINATION SWITCH READING FUNCTION

1. Description

- BCM reads combination switch (light, wiper washer, turn signal) status, and controls various electrical components according to the results.
- BCM reads information of 20 switches and 5 diagnostic results by combining five output terminals (OUTPUT 1 - 5) and five input terminals (INPUT 1 - 5).

2. Operation description

- BCM outputs battery voltage from input terminals (INPUT 1 - 5) all the time. At the same time output terminals (OUTPUT 1 - 5) activate transistors in turn, and allow current to flow. At this time, if any (1 or more) of the switches are ON, the input terminals corresponding to these switches detect current flow, and BCM judges switches are ON.

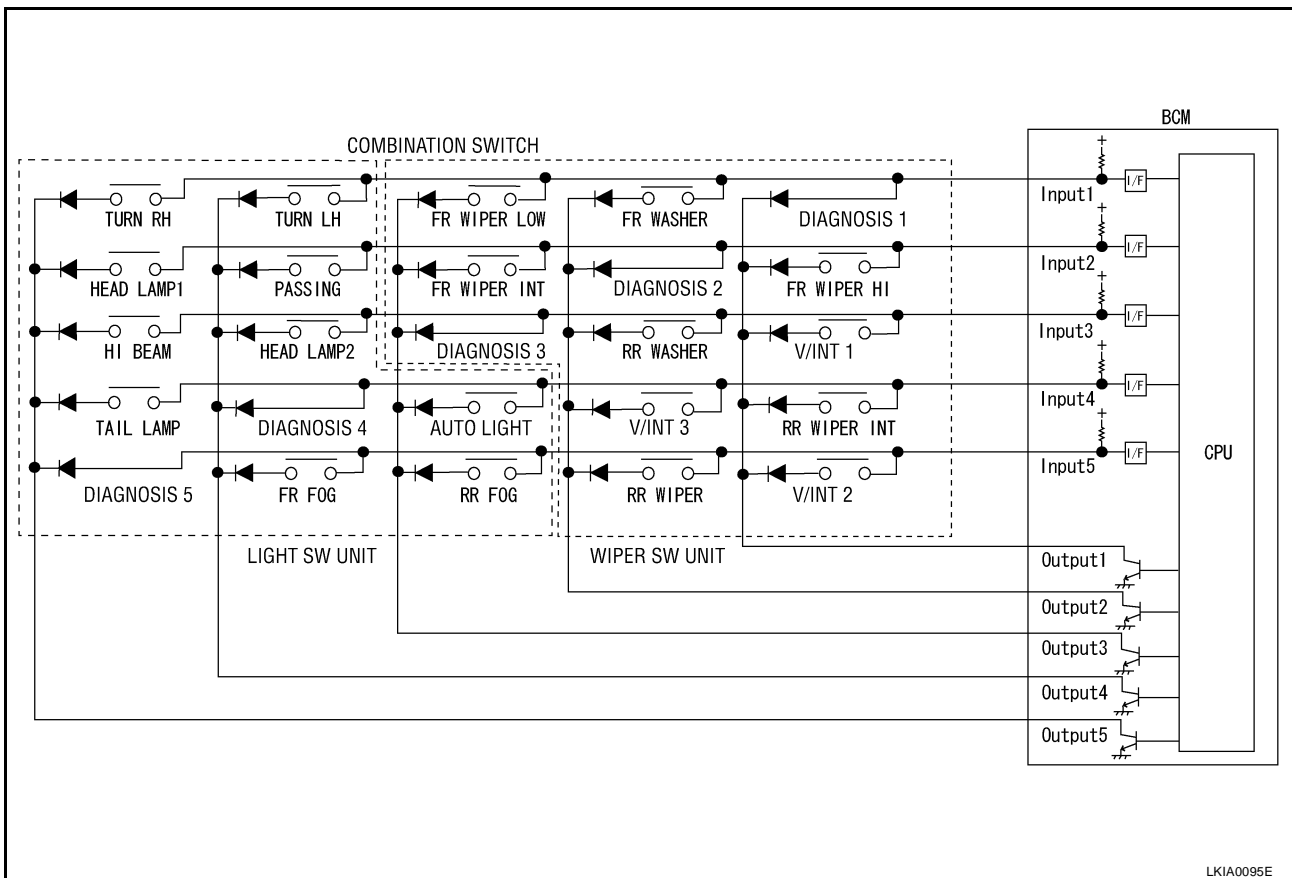

3. Example (When fog lamp switch is turned ON)

- When fog lamp switch is turned ON, contact in combination switch turns ON. At this time if OUTPUT 4 transistor is activated, BCM detects current flow in INPUT 5.
- When OUTPUT 4 transistor is ON, BCM detects current flow in INPUT5, and judges fog lamp switch is ON. Then BCM sends fog lamp ON signal to IPDM E/R using CAN communication.
- When OUTPUT 4 transistor is activated again, BCM detects current flow in INPUT 5, and confirms fog lamp switch is continuously ON.

BCM (BODY CONTROL MODULE)

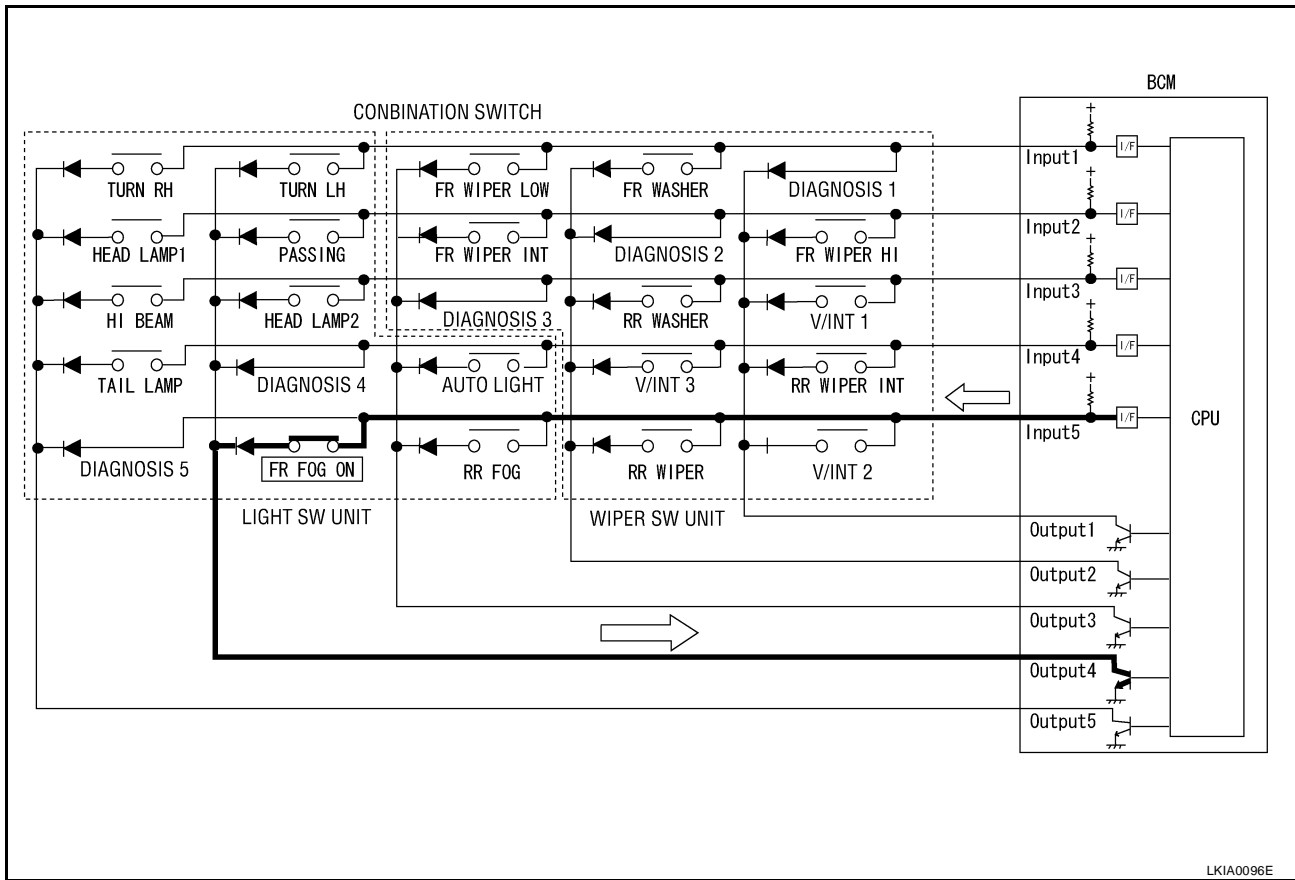

LKIA0096E

NOTE:

Each OUTPUT terminal transistor is activated at 10 ms interval. Therefore, after a switch is turned ON, the electrical loads are activated with a time delay. But this time delay is so short that it cannot be noticed.

4. BCM - Operation table of combination switches

- BCM reads operation status of combination switches by the combination shown in the table.

	COMB SW INPUT 1		COMB SW INPUT 2		COMB SW INPUT 3		COMB SW INPUT 4		COMB SW INPUT 5	
	ON	OFF	ON	OFF	ON	OFF	ON	OFF	ON	OFF
COMB SW OUTPUT 1	DIAGNOSIS 1 OK	DIAGNOSIS 1 NG	FR WIPER HI ON	FR WIPER HI OFF	V/INT 1 ON	V/INT 1 OFF	RR WIPER INT ON	RR WIPER INT OFF	V/INT 2 ON	V/INT 2 OFF
COMB SW OUTPUT 2	FR WASHER ON	FR WASHER OFF	DIAGNOSIS 2 OK	DIAGNOSIS 2 NG	RR WASHER ON	RR WASHER OFF	V/INT 3 ON	V/INT 3 OFF	RR WIPER ON	RR WIPER OFF
COMB SW OUTPUT 3	FR WIPER LOW ON	FR WIPER LOW OFF	FR WIPER INT ON	FR WIPER INT OFF	DIAGNOSIS 3 OK	DIAGNOSIS 3 NG	AUTO LIGHT ON	AUTO LIGHT OFF	RR FOG ON	RR FOG OFF
COMB SW OUTPUT 4	TURN LH ON	TURN LH OFF	PASSING ON	PASSING OFF	HEAD LAMP 2 ON	HEAD LAMP 2 OFF	DIAGNOSIS 4 OK	DIAGNOSIS 4 NG	FR FOG ON	FR FOG OFF
COMB SW OUTPUT 5	TURN RH ON	TURN RH OFF	HEAD LAMP ON	HEAD LAMP OFF	HI BEAM ON	HI BEAM OFF	LIGHTING SWITCH 1ST POSITION ON	LIGHTING SWITCH 1ST POSITION OFF	DIAGNOSIS 5 OK	DIAGNOSIS 5 NG

LKIA0097E

NOTE:

Headlamp has a dual system switch for safe operation.

5. Operation mode

BCM (BODY CONTROL MODULE)

- Combination switch reading function has operation modes shown below.
- Normal mode
 - When BCM is not in sleep mode, each OUTPUT (1 - 5) terminal turns ON-OFF at 10 ms intervals.
 - Sleep mode
 - When BCM is in sleep mode, transistors of OUTPUT 1 and 2 stop the output, and BCM enters low-current-consumption mode. OUTPUTS (3 - 5) turn ON-OFF at 60 ms intervals, and receives lighting switch input only.

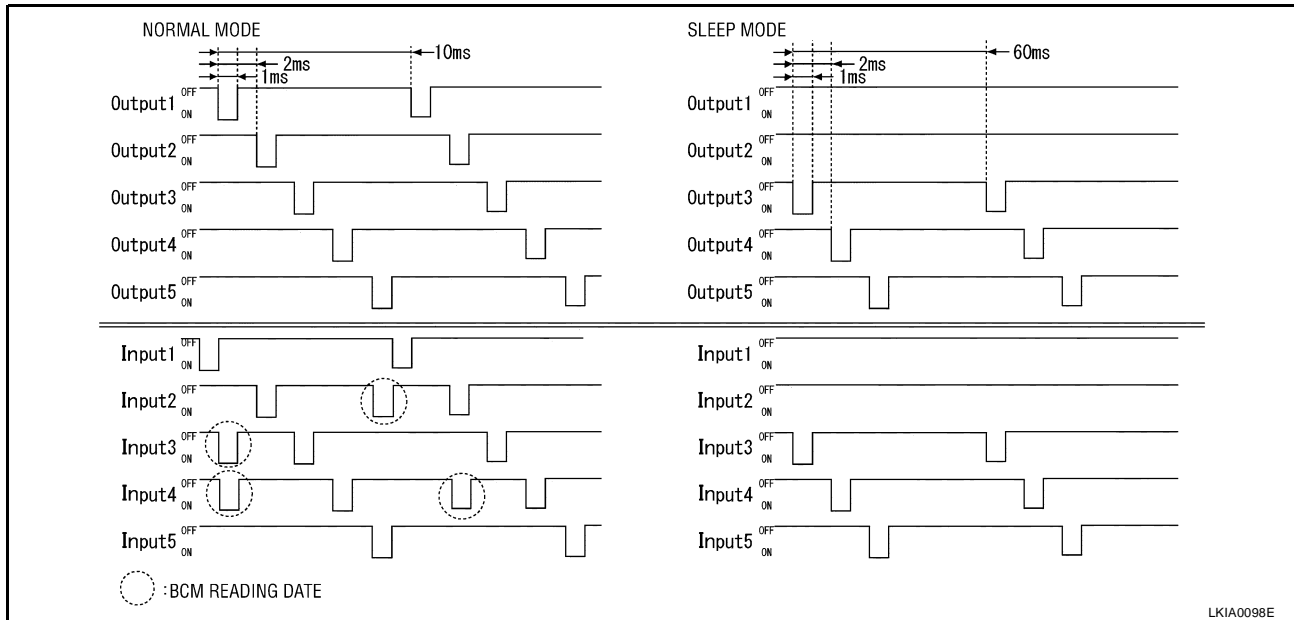

CAN COMMUNICATION CONTROL

CAN communication is capable of dealing with a lot of information through the two communication lines (CAN L-line, CAN H-line) connecting control units in the system. Also each control unit functions to transmit and receive data, and reads necessary information only.

BCM STATUS CONTROL

BCM changes its status depending on the operation status in order to save power consumption.

- CAN communication status
 - With ignition switch ON, CAN communicates with other control units normally.
 - Control by BCM is being operated properly.
 - When ignition switch is OFF, switching to sleep mode is possible.
 - Even when ignition switch is OFF, if CAN communication with IPDM E/R and combination meter is active, CAN communication status is active.
- Sleep status
 - This is the status to stop CAN communication when ignition switch is turned OFF.
 - It transmits sleep request signal to IPDM E/R and combination meter.
 - Two seconds after CAN communication with other control unit stops, it switches to CAN communication inactive status.
- CAN communication inactive status
 - With ignition switch OFF, CAN communication is not active.
 - With ignition switch OFF, control performed only by BCM is active.
 - Two seconds after CAN communication with other control unit stops, it switches to CAN communication inactive status.
- Sleep status
 - BCM is activated with low-current-consumption mode.
 - CAN communication is not active.

BCM (BODY CONTROL MODULE)

- When CAN communication operation is detected, it switches to CAN communication status.
- When control performed only by BCM is required by switch, it shifts to CAN communication inactive mode.
- It changes combination switch reading function.

SYSTEMS CONTROLLED BY BCM DIRECTLY

- Power door lock system. Refer to [BL-16, "POWER DOOR LOCK SYSTEM"](#) .
- Remote keyless entry system. Refer to [BL-43, "REMOTE KEYLESS ENTRY SYSTEM"](#) .
- Power window system. Refer to [GW-15, "POWER WINDOW SYSTEM"](#) . NOTE
- Sunroof system. Refer to [RF-10, "SUNROOF"](#) . NOTE
- Room lamp timer. Refer to [LT-123, "INTERIOR ROOM LAMP"](#) .
- Key reminder
- Warning chime
- Turn signal and hazard warning lamps

NOTE:

Power supply only. No system control.

SYSTEMS CONTROLLED BY BCM AND IPDM E/R

- Headlamp, tail lamp, fog lamp, auto light system
- Wiper
- Front washer
- Rear window defogger

MAJOR COMPONENTS AND CONTROL SYSTEM

System	Input	Output
Remote keyless entry system	—	All-door locking actuator Trunk lid opener actuator
Power door lock system	<ul style="list-style-type: none"> ● Power door lock switch ● Driver door lock switch 	All-door locking actuator
Power supply (IGN) to power window, sunroof	Ignition power supply	Power supply to power window and sunroof system
Power supply (BAT) to power window, sunroof and power seat	Battery power supply	Power supply to power window, sunroof system and power seat
Auto light system	Auto light sensor Combination switch	IPDM E/R
Headlamp	Combination switch	IPDM E/R
Tail lamp	Combination switch	IPDM E/R
Fog lamp	Combination switch	IPDM E/R
Turn signal lamp	Combination switch	Turn signal lamp Combination meter
Hazard lamp	Hazard switch	Turn signal lamp Combination meter
Room lamp timer	Key detection switch Driver door lock switch Driver door switch All-door switch	Interior room lamp
Key warning chime	Key detection switch Driver door switch	Combination meter (warning buzzer)
Light warning chime	Combination switch Key detection switch Driver door switch	Combination meter (warning buzzer)
Vehicle-speed-sensing intermittent wiper	Combination switch Combination meter	IPDM E/R

BCM (BODY CONTROL MODULE)

System	Input	Output
Front washer	Combination switch	Front washer motor IPDM E/R
Rear window defogger	Rear defogger switch	IPDM E/R
Air conditioner switch signal	A/C auto amplifier (with auto A/C) A/C control unit (with manual A/C)	ECM
Blower fan switch signal	A/C auto amplifier (with auto A/C) A/C control unit (with manual A/C)	ECM

CAN Communication System Description

EKS002J9

CAN (Controller Area Network) is a serial communication line for real time application. It is an on-vehicle multiplex communication line with high data communication speed and excellent error detection ability. Many electronic control units are equipped onto a vehicle, and each control unit shares information and links with other control units during operation (not independent). In CAN communication, control units are connected with 2 communication lines (CAN H line, CAN L line) allowing a high rate of information transmission with less wiring. Each control unit transmits/receives data but selectively reads required data only.

FOR TCS MODELS

System diagram

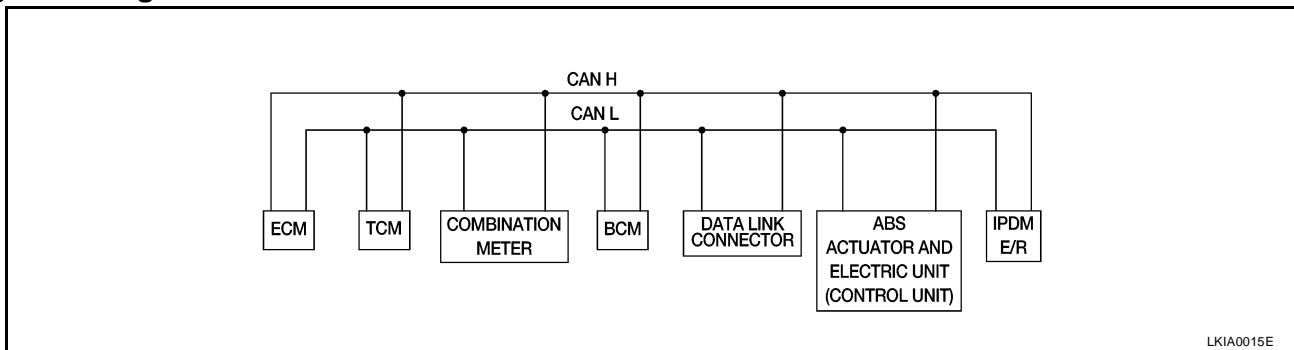

LKIA0015E

Input/output signal chart

T: Transmit R: Receive

Signals	ECM	TCM	COMBINATION METER	BCM	ABS/TCS control unit	IPDM E/R
Engine speed signal	T		R		R	
Engine coolant temperature signal	T		R			
Accelerator pedal position signal	T					
Fuel consumption monitor signal	T		R			
A/T warning lamp signal		T	R			
A/T position indicator signal	R		R	R ^(R range only)	R	
ABS operation signal	R				T	
TCS operation signal	R	R			T	
Air conditioner switch signal	R			T		
Air conditioner compressor signal	R					T
A/C compressor request signal	T					R
Cooling fan motor operation signal	R					T
Cooling fan speed request signal	T					R
Position lights request			R	T		R
Position lights status				R		T
Low beam request				T		R
Low beam status	R			R		T

BCM (BODY CONTROL MODULE)

Signals	ECM	TCM	COMBINATION METER	BCM	ABS/TCS control unit	IPDM E/R
High beam request			R	T		R
High beam status	R			R		T
Front fog lights request				T		R
Front fog light status				R		T
OD cancel switch signal		R	T			R
Brake switch signal		R	T			
Vehicle speed signal	R	T				
	R		T	R		
Oil pressure switch			R			T
Sleep request1			R	T		
Sleep request2				T		R
N range switch signal		R	T			
P range switch signal		R	T			
Seat belt buckle switch signal			T	R		
Door switch signal			R	T		R
Tail lamp request			R	T		R
Turn indicator signal			R	T		
Buzzer output signal			R	T		
Trunk switch signal			R	T		
ASCD main switch signal	T		R			
ASCD cruise signal	T		R			
Wiper operation				R		T
Wiper stop position signal				R		T
Rear window defogger switch signal				T		R
Rear window defogger control signal	R			R		T

FOR A/T MODELS

System diagram

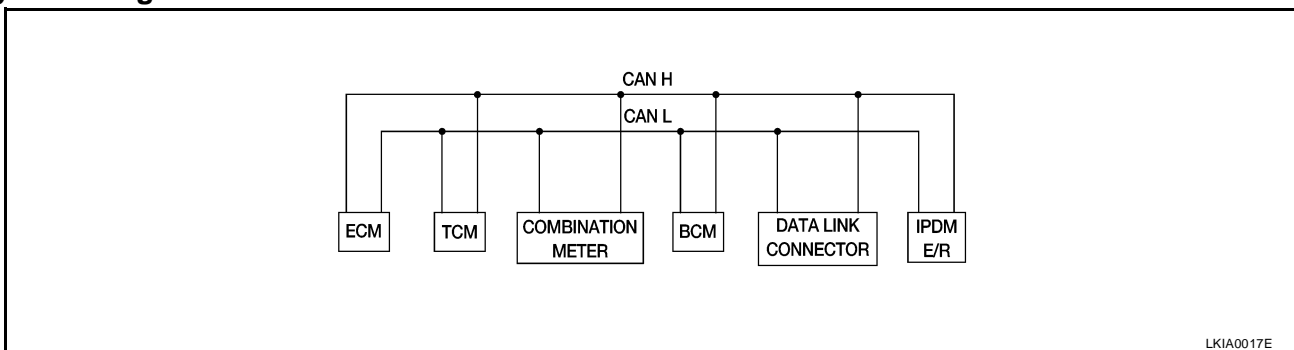

LKIA0017E

Input/output signal chart

T: Transmit R: Receive

Signals	ECM	TCM	COMBINATION METER	BCM	IPDM E/R
Engine speed signal	T		R		
Engine coolant temperature signal	T		R		
Accelerator pedal position signal	T				R

BCM (BODY CONTROL MODULE)

Signals	ECM	TCM	COMBINATION METER	BCM	IPDM E/R	
Fuel consumption monitor signal	T		R			A
A/T warning lamp signal		T	R			B
A/T position indicator signal	R	T	R	R(R range only)		B
Air conditioner switch signal	R			T		
Air conditioner compressor signal	R				T	C
A/C compressor request signal	T				R	
Blower fan switch signal	R(QR25DE)			T		D
Cooling fan motor operation signal	R			T		
Cooling fan speed request signal	T				R	
Position lights request			R	T	R	E
Position lights status				R	T	
Low beam request				T	R	
Low beam status	R			R	T	F
High beam request			R	T	R	
High beam status	R			R	T	G
Front fog lights request				T	R	
Front fog light status				R	T	
OD cancel switch signal		R	T		R	H
Brake switch signal		R	T			
Vehicle speed signal	R	T				I
	R		T	R		
Oil pressure switch			R		T	
Sleep request1			R	T		J
Sleep request2				T	R	
N range switch signal		R	T			
P range switch signal		R	T			
Seat belt buckle switch signal			T	R		
Door switch signal			R	T	R	L
Tail lamp request			R	T	R	
Turn indicator signal			R	T		
Buzzer output signal			R	T		M
Trunk switch signal			R	T		
ASCD main switch signal	T		R			
ASCD cruise signal	T		R			
Wiper operation				R	T	
Wiper stop position signal				R	T	
Rear window defogger switch signal				T	R	
Rear window defogger control signal	R			R	T	

BCS

BCM (BODY CONTROL MODULE)

FOR M/T MODELS

System diagram

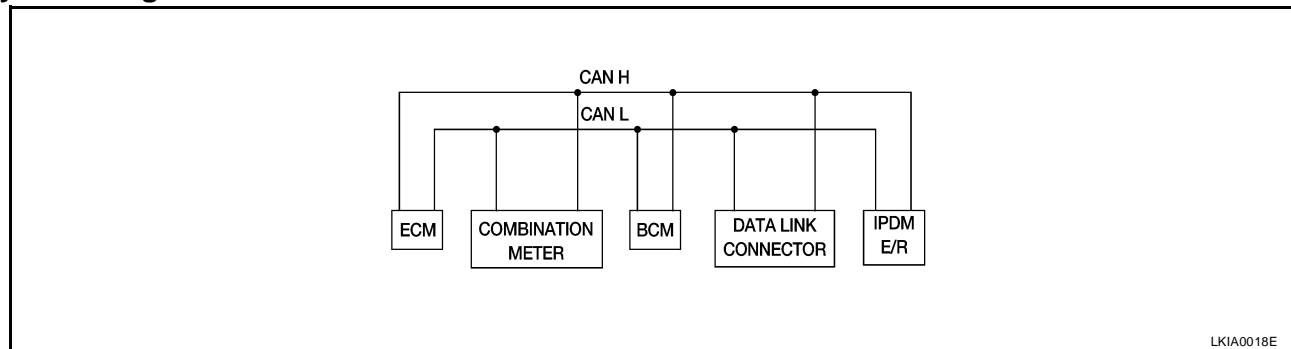

LKIA0018E

Input/output signal chart

T: Transmit R: Receive

Signals	ECM	COMBINATION METER	BCM	IPDM E/R
Engine speed signal	T			
Engine coolant temperature signal	T			
Fuel consumption monitor signal	T			
Air conditioner switch signal	R		T	
Air conditioner compressor signal	R			T
A/C compressor request signal	T			R
Blower fan switch signal	R(QR25DE)		T	
Cooling fan motor operation signal	R			T
Cooling fan speed request signal	T			R
Position lights request		R	T	R
Position lights status			R	T
Low beam request			T	R
Low beam status	R		R	T
High beam request		R	T	R
High beam status	R		R	T
Front fog lights request			T	R
Front fog light status			R	T
Vehicle speed signal	R	T		
Oil pressure switch		R		T
Sleep request1		R	T	
Sleep request2			T	R
Seat belt buckle switch signal		T	R	
Door switch signal		R	T	R
Tail lamp request		R	T	R
Turn indicator signal		R	T	
Buzzer output signal		R	T	
Trunk switch signal		R	T	
ASCD main switch signal	T	R		
ASCD cruise signal	T	R		
Wiper operation			R	T
Wiper stop position signal			R	T

BCM (BODY CONTROL MODULE)

Signals	ECM	COMBINATION METER	BCM	IPDM E/R
Rear window defogger switch signal			T	R
Rear window defogger control signal	R		R	T

A

B

C

D

E

F

G

H

I

J

BCS

L

M

BCM (BODY CONTROL MODULE)

Schematic

EKS002JA

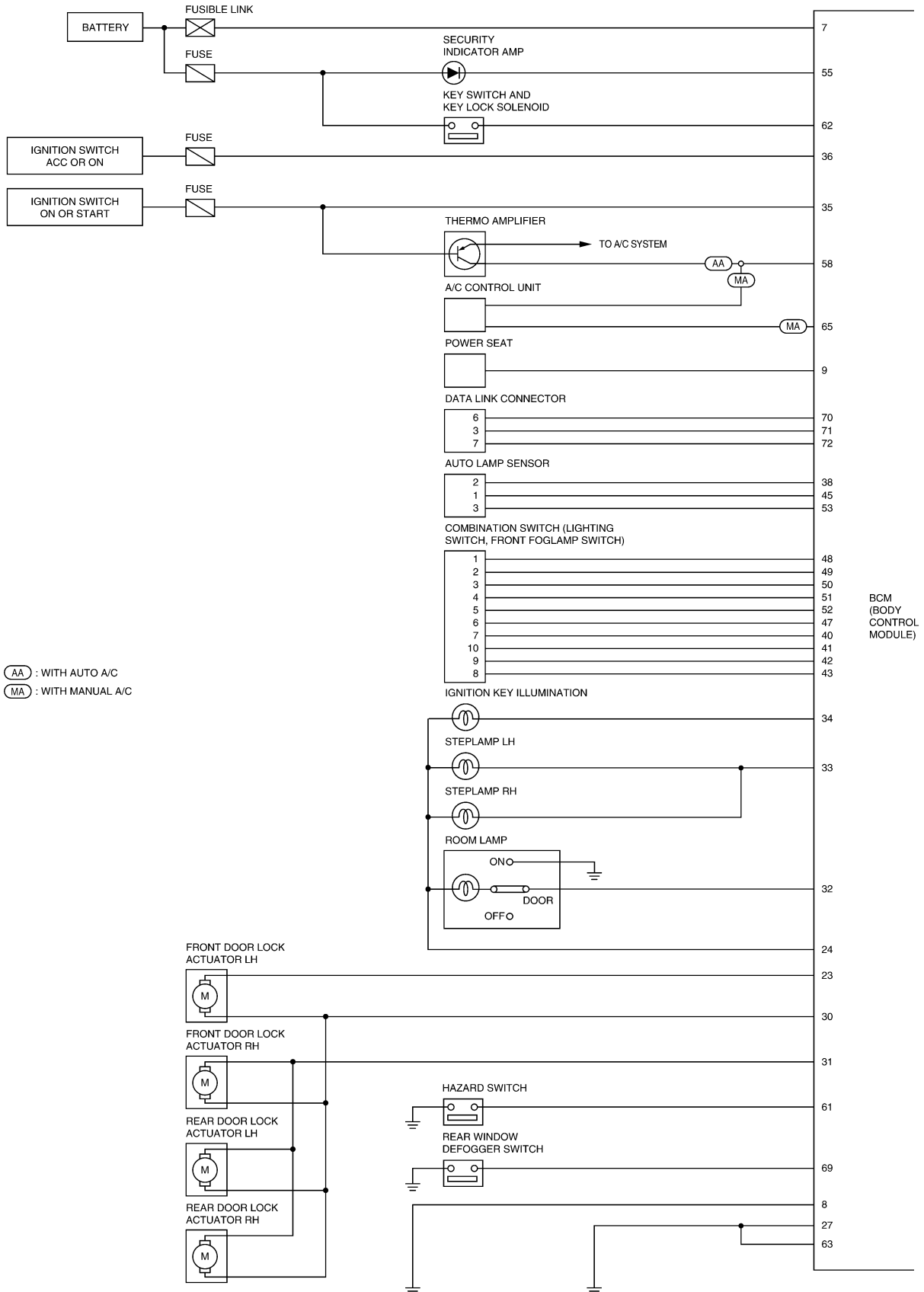

LKWA0071E

BCM (BODY CONTROL MODULE)

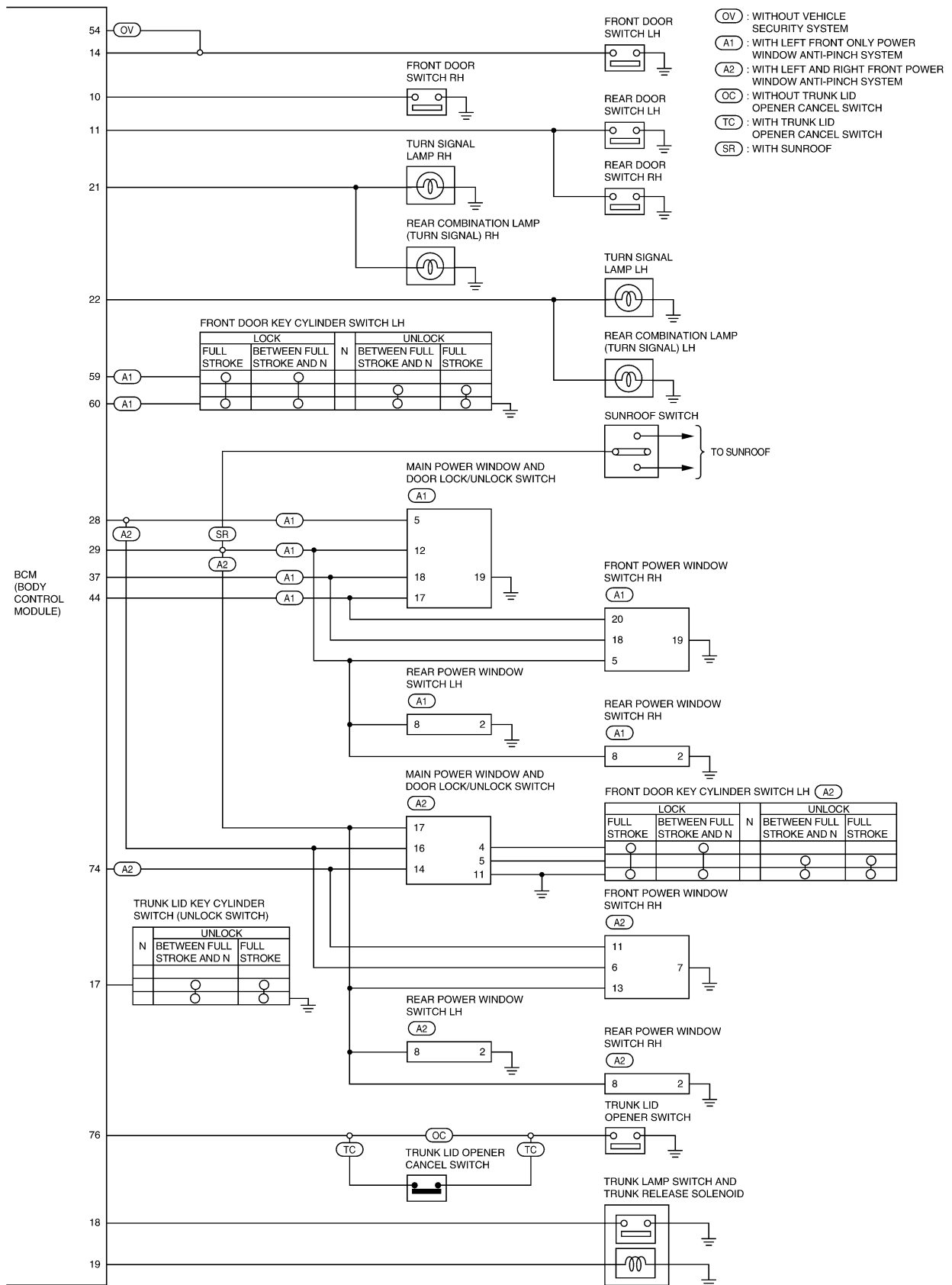

A
B
C
D
E
F
G
H
I
J
L
M

BCS

BCM (BODY CONTROL MODULE)

EKS002JB

CONSULT-II

CONSULT-II can display each diagnostic item using the following diagnostic test modes: work support, self-diagnostic results, data monitor and active test through data reception and command transmission via the BCM communication line.

BCM diagnostic test item	Check item, diagnostic test mode	Content
Inspection by part	Work support	Changes setting of each function.
	Self-diag results	BCM performs self-diagnosis of CAN communication and combination switch.
	Data monitor	Displays the input data of BCM in real time.
	Active test	Gives a drive signal to a load to check the operation.

CONSULT-II INSPECTION PROCEDURE

1. With ignition switch OFF, connect CONSULT-II to data link connector and turn ON ignition switch.
2. Touch "START".

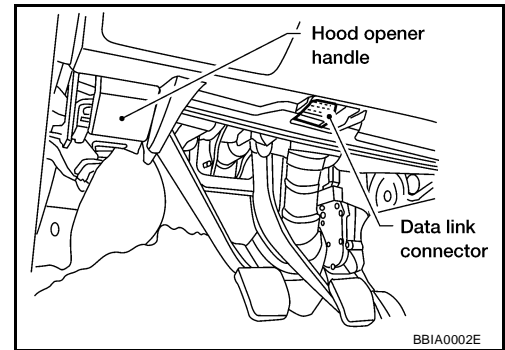

3. Touch "BCM" on "SELECT SYSTEM" screen.

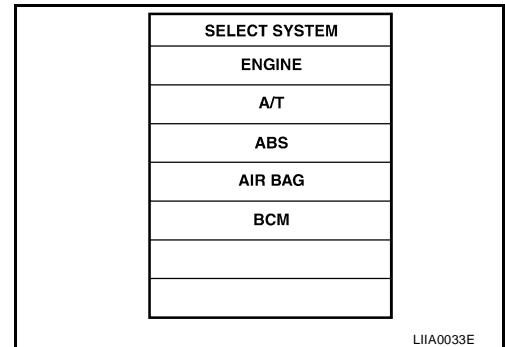

4. Select item to be diagnosed on "SELECT TEST ITEM" screen.

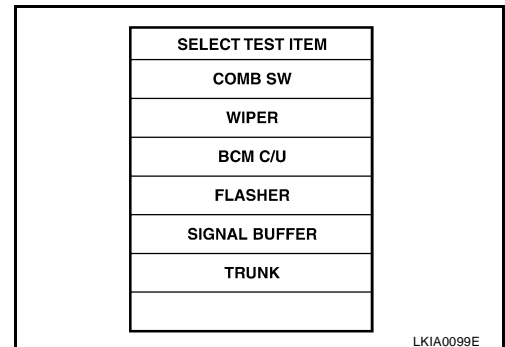

ITEMS OF EACH PART

System and item	CONSULT-II display	Diagnostic test mode (Inspection by part)			
		WORK SUPPORT	SELF-DIAG RESULTS	DATA MONITOR	ACTIVE TEST
Power door lock system	Door lock			×	×
Rear defogger	Rear defogger			×	×
Key reminder	Key reminder			×	×

BCM (BODY CONTROL MODULE)

System and item	CONSULT-II display	Diagnostic test mode (Inspection by part)			
		WORK SUPPORT	SELF-DIAG RESULTS	DATA MONITOR	ACTIVE TEST
Light reminder	Light reminder			×	×
Room lamp timer	Interior room lamp	×		×	×
Power supply (IGN) to power window and sunroof	RAP			×	×
Remote keyless entry system	Keyless entry	×		×	×
Headlamp	Headlamp	× NOTE 1		× NOTE 2	
Combination switch	Combination switch			× NOTE 2	
BCM	BCM control unit		×	×	
Turn signal lamp Hazard lamp	Flasher			×	×
Air conditioner switch signal Blower fan switch signal	Signal buffer			×	
Reverse warning buzzer	Reverse warning			×	×

CAUTION:

- For vehicles with auto light only
- For vehicles without auto light, related items are displayed, but monitoring cannot be performed.

CAN Communication Inspection Using CONSULT-II (Self-Diagnosis)

EKS002JC

1. SELF-DIAGNOSTIC RESULT CHECK

- Connect to CONSULT-II, and select "BCM" on "SELECT SYSTEM" screen.
- Select "BCM control unit" on "SELECT WORK ITEM" screen, and select "SELF-DIAG RESULTS".
- Check display content in self-diagnostic results.

CONSULT-II display code	Diagnosis item
U1000	CAN COMM
	CAN CIRC 1
	CAN CIRC 2
	CAN CIRC 3
	CAN CIRC 4

Contents displayed

No malfunction>>Inspection End
Malfunction in CAN communication system>>GO TO 2.

2. SYMPTOM CHECK

- Select "CAN diagnosis support monitor" in data monitor.
- Select "START" and check display content.

Diagnosis item	Self-diagnostic result content	
	Normal	Not normal (Example)
CAN COMM	OK	NG
CAN CIRC 1	OK	UNKWN
CAN CIRC 2	OK	UNKWN
CAN CIRC 3	OK	UNKWN
CAN CIRC 4	OK	UNKWN

>> After printing the monitor items, go to "CAN System". Refer to [LAN-4, "CAN COMMUNICATION"](#).

BCM (BODY CONTROL MODULE)

Combination Switch Inspection According to Self-Diagnostic Results

EKS002JD

1. SELF-DIAGNOSTIC RESULT CHECK

1. Connect to CONSULT-II, and select "BCM" on "SELECT SYSTEM" screen.
2. Select "BCM control unit" on "SELECT WORK ITEM" screen, and select "SELF-DIAG RESULTS".
3. Check display content in self-diagnostic results.

CONSULT-II display code	Self-diagnostic result content	Malfunctioning switch system	Detection conditions	Possible causes
B2049	OPEN DETECT 1	The following switch operation shown below cannot be input. <ul style="list-style-type: none"> ● Front wiper Hi ● Intermittent control 1 ● Intermittent control 2 	BCM terminal No. 48 (Input 1) does not change. (Open circuit in diagnosis 1 system line or open malfunction in output 1 transistor.)	<ul style="list-style-type: none"> ● Vehicle harness between BCM and combination switch ● Wiper switch ● BCM
B2050	OPEN DETECT 2	The following switch operation shown below cannot be input. <ul style="list-style-type: none"> ● Front washer ● Intermittent control 3 	BCM terminal No. 47 (Input 2) does not change. (Open circuit in diagnosis 2 system line or open malfunction in output 2 transistor.)	<ul style="list-style-type: none"> ● Vehicle harness between BCM and combination switch ● Wiper switch ● BCM
B2051	OPEN DETECT 3	The following switch operation shown below cannot be input. <ul style="list-style-type: none"> ● Front wiper Lo ● Front wiper INT ● Auto light 	BCM terminal No. 46 (Input 3) does not change. (Open circuit in diagnosis 3 system line or open malfunction in output 3 transistor.)	<ul style="list-style-type: none"> ● Vehicle harness between BCM and combination switch ● Wiper switch (Front wiper Lo, INT) ● Lighting switch (Auto light) ● BCM
B2052	OPEN DETECT 4	The following switch operation shown below cannot be input. <ul style="list-style-type: none"> ● TURN LH ● PASSING ● Headlamp 2 ● Front fog lamp 	BCM terminal No. 45 (Input 4) does not change. (Open circuit in diagnosis 4 system line or open malfunction in output 4 transistor.)	<ul style="list-style-type: none"> ● Vehicle harness between BCM and combination switch ● Lighting switch ● BCM
B2053	OPEN DETECT 5	The following switch operation shown below cannot be input. <ul style="list-style-type: none"> ● TURN RH ● Headlamp 1 ● HI BEAM ● Lighting switch 1st position 	BCM terminal No. 44 (Input 5) does not change. (Open circuit in diagnosis 5 system line or open malfunction in output 5 transistor.)	<ul style="list-style-type: none"> ● Vehicle harness between BCM and combination switch ● Lighting switch ● BCM
B2054	HEADLAMP 1 SW NG	Headlamp 1 malfunction	Headlamp 1 switch OFF Headlamp 2 switch ON	Lighting switch
B2055	HEADLAMP 2 SW NG	Headlamp 2 malfunction	Headlamp 1 switch ON Headlamp 2 switch OFF	Lighting switch

Display content

No malfunction>>Inspection End

Malfunction in diagnosis system>>GO TO 2.

Malfunction in headlamp switch system>>Replace lamp switch.

BCM (BODY CONTROL MODULE)

2. HARNESS INSPECTION

1. Disconnect BCM connector and combination switch connector.
2. Check continuity between BCM harness connector of applicable malfunctioning system and combination switch connector terminals.

Self-diagnostic result content	Terminals				Continuity	
	BCM(+)		Combination switch(-)			
	Connector	Terminal (wire color)	Connector	Terminal (wire color)		
OPEN DETECT 1	M19	Input 1	48(G/W)	M28	1(G/W)	Yes
		Output 1	47(R/W)		6(R/W)	
OPEN DETECT 2		Input 2	49(G/B)		2(G/B)	
		Output 2	40(R/B)		7(R/B)	
OPEN DETECT 3		Input 3	50(G/R)		3(G/R)	
		Output 3	41(R/G)		10(R/G)	
OPEN DETECT 4		Input 4	51(G/Y)		4(G/Y)	
		Output 4	42(R/Y)		9(R/Y)	
OPEN DETECT 5		Input 5	52(L/W)		5(L/W)	
		Output 5	43(L)		8(L)	

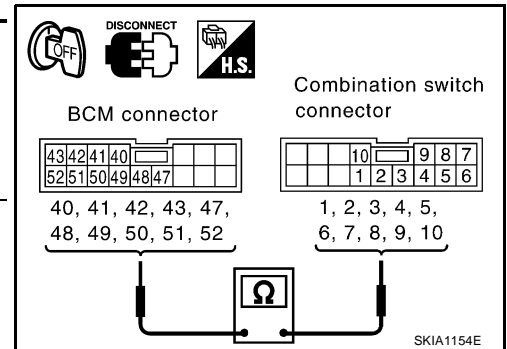

- Refer to [LT-12. "Wiring Diagram — H/LAMP —"](#).

OK or NG

OK >> GO TO 3.

NG >> Check harness between BCM and combination switch for open or short circuit.

3. INSPECTION OF BCM INPUT TERMINAL VOLTAGE

Connect BCM connector, and check BCM input terminal voltage of applicable malfunctioning system.

Self-diagnostic result content	Terminals		Voltage	
	BCM			
	Connector	Terminal (wire color)		
OPEN DETECT 1	M19	Input 1	48(G/W)	4.5V or more
OPEN DETECT 2		Input 2	49(G/B)	
OPEN DETECT 3		Input 3	50(G/R)	
OPEN DETECT 4		Input 4	51(G/Y)	
OPEN DETECT 5		Input 5	52(L/W)	

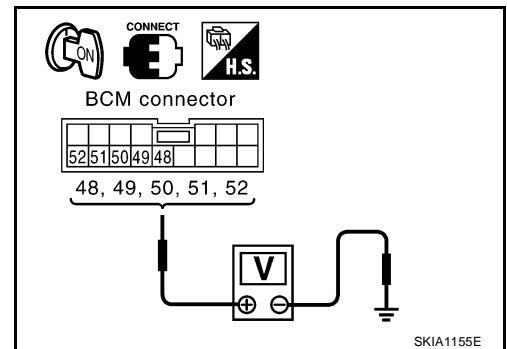

- Refer to [LT-12. "Wiring Diagram — H/LAMP —"](#).

OK or NG

OK >> GO TO 4.

NG >> Replace BCM.

BCM (BODY CONTROL MODULE)

4. BCM OUTPUT TERMINAL INSPECTION

Connect combination switch connector, and check BCM output terminal voltage waveform of applicable malfunctioning system.

Self-diagnostic result content	Terminals		
	BCM		
	Connector	Terminal (wire color)	
OPEN DETECT 1	M19	Output 1	47(R/W)
OPEN DETECT 2		Output 2	40(R/B)
OPEN DETECT 3		Output 3	41(R/G)
OPEN DETECT 4		Output 4	42(R/Y)
OPEN DETECT 5		Output 5	43(L)

- Refer to [LT-12, "Wiring Diagram — H/LAMP —"](#).

OK or NG

OK >> Combination switch malfunction, go to 5.

NG >> Replace BCM.

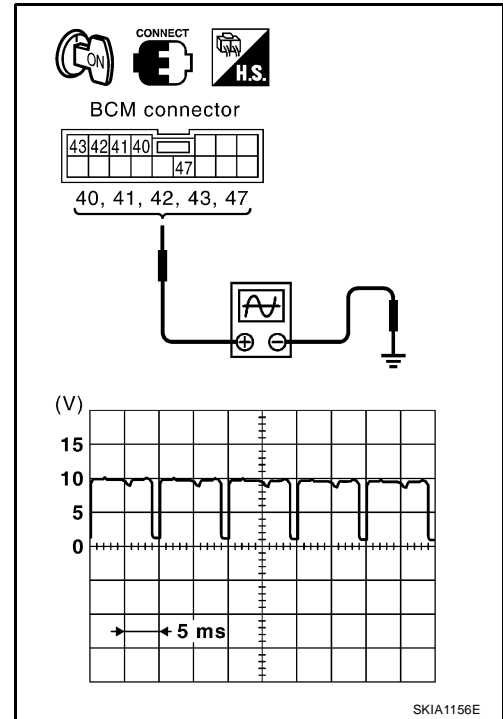

5. COMBINATION SWITCH INSPECTION

Following the table below, check switches by procedure of appropriate malfunctioning system.

Self-diagnostic result content	Procedure									
	1	2	3	4	5	6	7	8	9	10
OPEN DETECT 1	Wiper switch replacement	Confirm self-diagnostic results again.	OK	Inspection End	—					
			NG	Confirm symptom again.						
OPEN DETECT 2	Wiper switch replacement	Confirm self-diagnostic results again.	OK	Inspection End	—					
			NG	Confirm symptom again.						
OPEN DETECT 3	Lighting switch replacement	Confirm self-diagnostic results again.	OK	Inspection End	Confirm self-diagnostic results again.	OK	Inspection End	Confirm self-diagnostic results again.	OK	Inspection End
			NG	Wiper switch replacement		NG	Switch base replacement		NG	Confirm symptom again.
OPEN DETECT 4	Lighting switch replacement	Confirm self-diagnostic results again.	OK	Inspection End	Confirm self-diagnostic results again.	OK	Inspection End	Confirm self-diagnostic results again.	OK	Inspection End
			NG	Wiper switch replacement		NG	Switch base replacement		NG	Confirm symptom again.
OPEN DETECT 5	Lighting switch replacement	Confirm self-diagnostic results again.	OK	Inspection End	Confirm self-diagnostic results again.	OK	Inspection End	Confirm self-diagnostic results again.	OK	Inspection End
			NG	Wiper switch replacement		NG	Switch base replacement		NG	Confirm symptom again.

BCM (BODY CONTROL MODULE)

>> Inspection End

Malfunctioning Operation of Lamps and Wipers

EKS002JE

1. SYMPTOM CHECK

Confirm symptom, and confirm malfunctioning system No. from the table below.

Ignition switch	Symptom	Malfunctioning system	Possible causes
ON	<ul style="list-style-type: none"> ● LH Turn signal lamp and RH Turn signal lamp on ● Front wiper on (LO speed) 	1	<ul style="list-style-type: none"> ● Vehicle harness shorted between BCM input terminal No. 1 and BCM output terminal No. 1 ● BCM ● Combination switch
OFF	—		
ON	<ul style="list-style-type: none"> ● Headlamp on (HI and LO) ● Front wiper on (HI speed) 	2	<ul style="list-style-type: none"> ● Vehicle harness shorted between BCM input terminal No. 2 and BCM output terminal No. 2 ● BCM ● Combination switch
OFF	Headlamp on (HI and LO)		
ON	Headlamp on (HI and LO)	3	<ul style="list-style-type: none"> ● Vehicle harness shorted between BCM input terminal No. 3 and BCM output terminal No. 3 ● BCM ● Combination switch
OFF	Headlamp on (HI and LO)		
ON	<ul style="list-style-type: none"> ● Parking lamp and Tail lamp on ● Headlamp on at certain degrees of brightness 	4	<ul style="list-style-type: none"> ● Vehicle harness shorted between BCM input terminal No. 4 and BCM output terminal No. 4 ● BCM ● Combination switch
OFF	Parking lamp and Tail lamp on		
ON	Front fog lamp on	5	<ul style="list-style-type: none"> ● Vehicle harness shorted between BCM input terminal No. 5 and BCM output terminal No. 5 ● BCM ● Combination switch
OFF	Front fog lamp on		

>> GO TO 2.

BCS

BCM (BODY CONTROL MODULE)

2. HARNESS INSPECTION

1. Disconnect BCM connector and combination switch connector.
2. Check continuity between BCM harness connector of applicable malfunctioning system and body ground.

Self-diagnostic result content	Terminals			Continuity	
	BCM(+)		(-)		
	Connector	Terminal (wire color)			
OPEN DETECT 1	M19	Input 1	48(G/W)	Ground	No
		Output 1	47(R/W)		
OPEN DETECT 2		Input 2	49(G/B)		
		Output 2	40(R/B)		
OPEN DETECT 3		Input 3	50(G/R)		
		Output 3	41(R/G)		
OPEN DETECT 4		Input 4	51(G/Y)		
		Output 4	42(R/Y)		
OPEN DETECT 5		Input 5	52(L/W)		
		Output 5	43(L)		

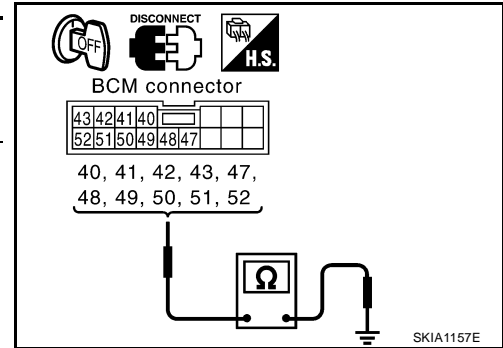

- Refer to [LT-12, "Wiring Diagram — H/LAMP —"](#) .

OK or NG

OK >> GO TO 3.

NG >> Check harness between BCM and combination switch for short circuit.

3. INSPECTION OF BCM INPUT TERMINAL VOLTAGE

Connect BCM connector. Check voltage between BCM input terminal of applicable malfunctioning system and body ground.

Self-diagnostic result content	Terminals			Voltage
	BCM(+)		(-)	
	Connector	Terminal (wire color)		
OPEN DETECT 1	M19	48(G/W)	Ground	4.5V or more
OPEN DETECT 2		49(G/B)		
OPEN DETECT 3		50(G/R)		
OPEN DETECT 4		51(G/Y)		
OPEN DETECT 5		52(L/W)		

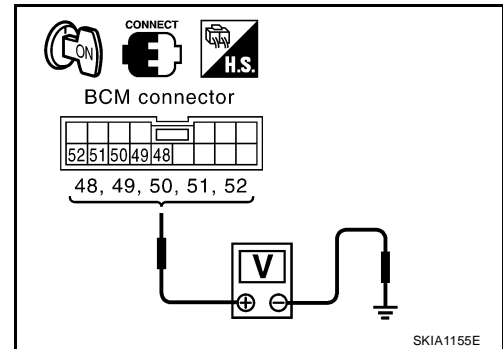

- Refer to [LT-12, "Wiring Diagram — H/LAMP —"](#) .

OK or NG

OK >> Combination switch malfunction, go to 4.

NG >> Replace BCM.

BCM (BODY CONTROL MODULE)

4. COMBINATION SWITCH INSPECTION

Following the table below, check combination switch.

Procedure									
1	2		3	4		5	6		7
Lighting switch replacement	Confirm self-diagnostic results again.	OK	Inspection End	Confirm self-diagnostic results again.	OK	Inspection End	Confirm self-diagnostic results again.	OK	Inspection End
		NG	Wiper switch replacement		NG	Replacement of switch base		NG	Confirm symptom again.

>> Inspection End

Inspection of BCM Power Supply and Ground Circuit

EKS002JF

1. FUSE AND FUSIBLE LINK INSPECTION

Check if any of the following BCM fuses and fusible links are blown.

Terminal No.	Signal name	Fuse No., fusible link No.
7	Battery	f
35	Ignition switch ON or START	12
36	Ignition switch ACC or ON	6

- Refer to [LT-12, "Wiring Diagram — H/LAMP —"](#).

OK or NG

OK >> GO TO 2.

NG >> Replace fuse or fusible link.

2. POWER SUPPLY CIRCUIT INSPECTION

Disconnect BCM connector. To measure voltage, connect following connector terminals to positive probe and body ground to negative one.

Terminals		(-)	Power source	Ignition switch	Reference voltage (V)
(+)	Connector				
7	E39	Ground	Battery power	OFF	Approx. 12
35	M19		Ignition power supply	ON	Approx. 12
36			ACC power supply	ACC	Approx. 12

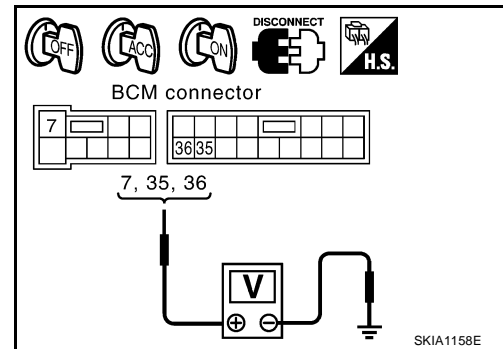

- Refer to [LT-12, "Wiring Diagram — H/LAMP —"](#).

OK or NG

OK >> GO TO 3.

NG >> Replace BCM power supply circuit harness.

BCM (BODY CONTROL MODULE)

3. GROUND CIRCUIT INSPECTION

Check continuity between the following connector of BCM and body ground.

Terminals		Power source	Ignition switch	Continuity
(+)	(-)			
Connector	Terminal (wire color)			
E39	8	Ground	OFF	YES

- Refer to [LT-12, "Wiring Diagram — H/LAMP —"](#).

OK or NG

- OK >> Normal
- NG >> Replace BCM ground circuit harness.

