

SECTION **MT**

GI

MA

EM

LC

EC

FE

CL

MT

AT

FA

RA

BR

ST

RS

BT

HA

EL

IDX



CONTENTS

PREPARATION	2	DISASSEMBLY	17
Special Service Tools.....	2	REPAIR FOR COMPONENT PARTS	20
Commercial Service Tools.....	4	Input Shaft and Gears.....	20
NOISE, VIBRATION AND HARSHNESS (NVH)		Mainshaft and Gears.....	25
TROUBLESHOOTING	5	Final Drive.....	29
NVH Troubleshooting Chart.....	5	Shift Control Components.....	32
Manual Transaxle.....	5	Case Components.....	32
DESCRIPTION	6	ADJUSTMENT	33
Cross-sectional View.....	6	Input Shaft End Play and Differential Side	
ON-VEHICLE SERVICE	7	Bearing Preload.....	33
Replacing Oil Seal.....	7	Mainshaft Bearing Preload.....	34
Position Switch Check.....	8	ASSEMBLY	37
REMOVAL AND INSTALLATION	9	SERVICE DATA AND SPECIFICATIONS (SDS)	41
Removal.....	9	General Specifications.....	41
Installation.....	12	Inspection and Adjustment.....	42
TRANSAXLE GEAR CONTROL	13		
MAJOR OVERHAUL	14		
Case Components.....	14		
Gear Components.....	15		
Shift Control Components.....	16		

PREPARATION

Special Service Tools

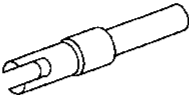
The actual shapes of Kent-Moore tools may differ from those of special service tools illustrated here.

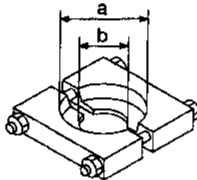
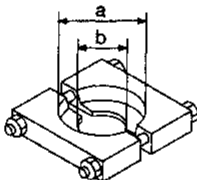
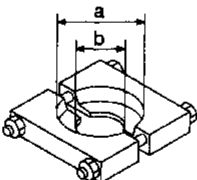
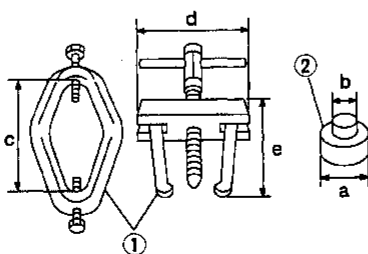
Tool number (Kent-Moore No.) Tool name	Description
KV38106500 (J34284) Preload adapter	 <p>Measuring turning torque of final drive assembly Measuring total turning torque Measuring clearance between side gear and differential case with washer Selecting differential side bearing adjusting shim</p> <p>NT087</p>
KV32101000 (J25689-A) Pin punch	 <p>Removing and installing retaining pin</p> <p>NT410</p> <p>a: 4 mm (0.16 in) dia.</p>
ST22730000 (J25681) Puller	 <p>Removing mainshaft front and rear bearing inner race</p> <p>NT411</p> <p>a: 82 mm (3.23 in) dia. b: 30 mm (1.18 in) dia.</p>
ST30031000 (J22912-01) Puller	 <p>Removing input shaft front and rear bearing Removing 4th & 5th main gear</p> <p>NT411</p> <p>a: 90 mm (3.54 in) dia. b: 50 mm (1.97 in) dia.</p>
ST30021000 (J22912-01) Puller	 <p>Removing 5th synchronizer Removing 3rd & 4th synchronizer Removing 2nd & 3rd main gear</p> <p>NT411</p> <p>a: 110 mm (4.33 in) dia. b: 68 mm (2.68 in) dia.</p>
ST3306S001 (J22888-D) Differential side bearing puller set ① ST33051001 (J22888-D) Puller ② ST33061000 (J8107-2) Adapter	 <p>Removing differential side bearing inner race</p> <p>AMT153</p> <p>a: 38 mm (1.50 in) dia. b: 28.5 mm (1.122 in) dia. c: 130 mm (5.12 in) d: 135 mm (5.31 in) e: 100 mm (3.94 in)</p>

PREPARATION

Special Service Tools (Cont'd)

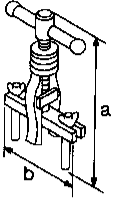
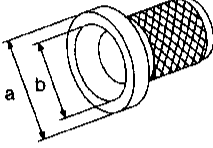
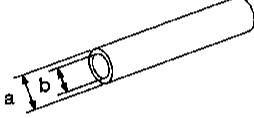
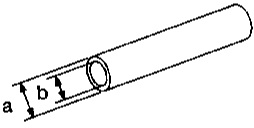
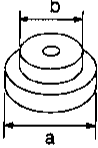
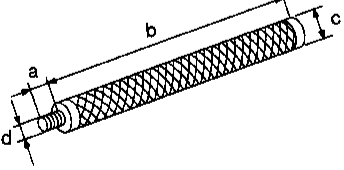
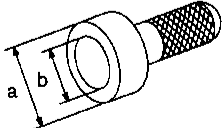
Tool number (Kent-Moore No.) Tool name	Description		
ST33290001 (J34286) Puller	 <p style="text-align: center;">NT414</p>	Removing differential oil seal Removing mainshaft rear bearing outer race Removing differential side bearing outer race a: 250 mm (9.84 in) b: 160 mm (6.30 in)	GI MA EM LC
ST33400001 (J26082) Drift	 <p style="text-align: center;">NT086</p>	Installing differential oil seal a: 60 mm (2.36 in) dia. b: 47 mm (1.85 in) dia.	EC FE
ST30600000 (J25863-01) Drift	 <p style="text-align: center;">NT065</p>	Installing input shaft front bearing a: 36 mm (1.42 in) dia. b: 31 mm (1.22 in) dia.	CL <div style="background-color: black; color: white; padding: 2px; display: inline-block;">MT</div> AT
ST22452000 (J34335) Drift	 <p style="text-align: center;">NT065</p>	Installing 3rd, 4th and 5th main gear a: 45 mm (1.77 in) dia. b: 36 mm (1.42 in) dia.	FA RA
ST30621000 (J25742-5) Drift	 <p style="text-align: center;">NT073</p>	Installing mainshaft rear bearing outer race (Use with ST30611000.) a: 79 mm (3.11 in) dia. b: 59 mm (2.32 in) dia.	BR ST RS
ST30611000 (J25742-1) Drift	 <p style="text-align: center;">NT419</p>	Installing mainshaft rear bearing outer race (Use with ST30621000.) a: 15 mm (0.59 in) b: 335 mm (13.19 in) c: 25 mm (0.98 in) dia. d: M12 x 1.5P	BT HA
ST307200000 (J25405) Drift	 <p style="text-align: center;">NT115</p>	Installing differential side bearing outer race a: 77 mm (3.03 in) dia. b: 55.5 mm (2.185 in) dia.	EL IDX

PREPARATION

Special Service Tools (Cont'd)

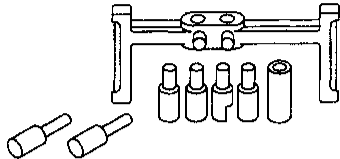
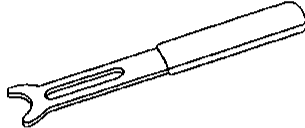
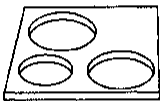
Tool number (Kent-Moore No.) Tool name	Description	
(J34290) Shim selecting tool set	 <p style="text-align: center;">NT080</p>	Selecting differential side bearing adjusting shim
(J34305) Snap ring remover and installer	 <p style="text-align: center;">NT081</p>	Removing and installing stopper ring of shift fork
(J25407-2)	 <p style="text-align: center;">NT082</p>	Measuring reverse baulk ring wear

Commercial Service Tools

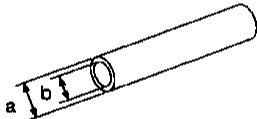
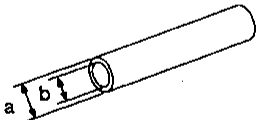
Tool name	Description	
Drift	 <p style="text-align: center;">NT065</p>	Installing differential side bearing inner race a: 45 mm (1.77 in) dia. b: 41 mm (1.61 in) dia.
Drift	 <p style="text-align: center;">NT065</p>	Installing striking rod oil seal a: 38 mm (1.50 in) dia. b: 20 mm (0.79 in) dia.

NVH Troubleshooting Chart

Use the chart below to help you find the cause of the symptom. The numbers indicate the order of inspection. If necessary, repair or replace these parts.

MANUAL TRANSAXLE

Symptom		SUSPECTED PARTS (Possible cause)												Reference page			
		Oil (Oil level is low.)	Oil (Wrong oil)	Oil (Oil level is too high.)	GASKET (Damaged)	OIL SEAL (Worn or damaged)	O-RING (Worn or damaged)	CONTROL ROD (Worn)	CHECK PLUG RETURN SPRING AND CHECK BALL (Worn or damaged)	SHIFT FORK (Worn)	GEAR (Worn or damaged)	BEARING (Worn or damaged)	BAULK RING (Worn or damaged)		INSERT SPRING (Damaged)		
Noise	Oil leakage	1	2								3	3					Refer to MA section ("Checking M/T Oil", "CHASSIS AND BODY MAINTENANCE").
	Hard to shift or will not shift		1	1				2					3	3			MT-14
	Jumps out of gear							1	2	3	3						MT-14

GI
MA
EM
LC
EC
FE
CL
MT
AT
FA
RA
BR
ST
RS
BT
HA
EL
IDX

DESCRIPTION

Cross-sectional View

RS5F50A

8

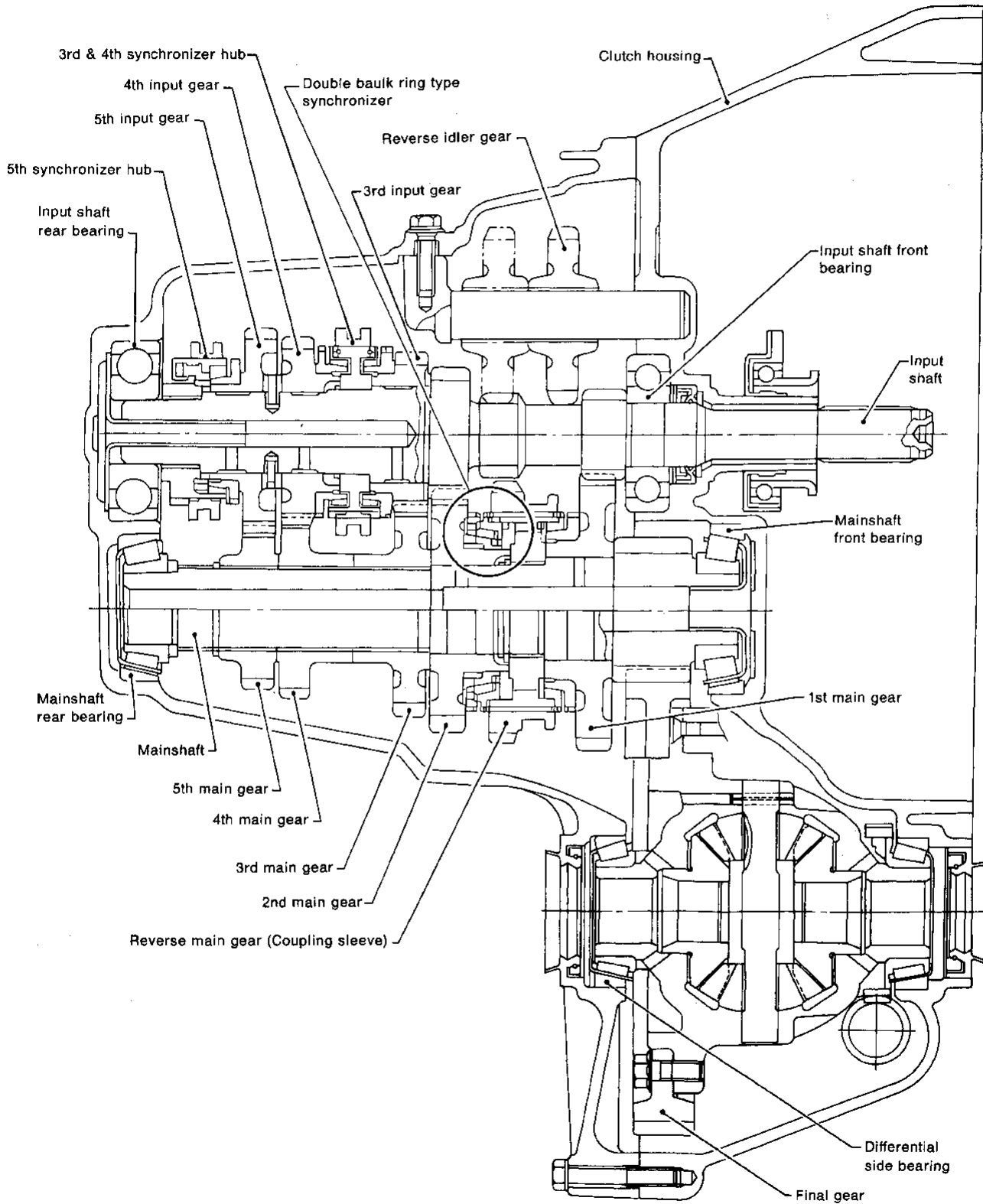

SMT196D

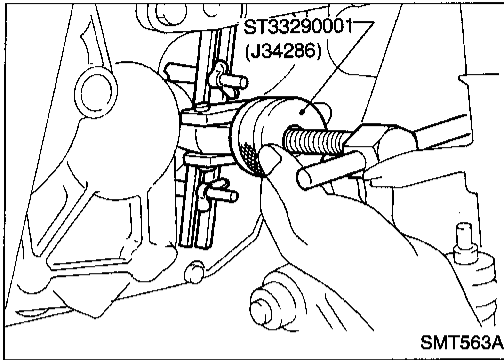

Replacing Oil Seal

DIFFERENTIAL OIL SEAL

1. Drain gear oil from transaxle.
2. Remove drive shafts. Refer to FA section ("REMOVAL", "FRONT AXLE — Drive Shaft").
3. Remove differential oil seal with Tool.
 - Always replace with a new seal once it has been removed.

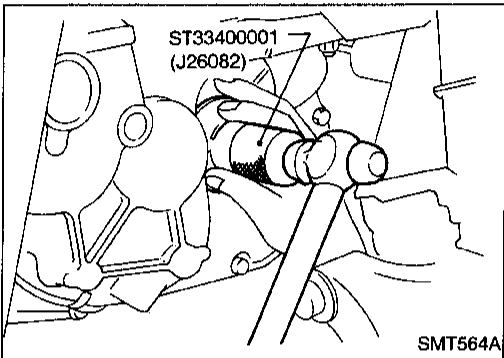

4. Install differential oil seal.
 - **Apply multi-purpose grease to seal lip of oil seal before installing.**
5. Install drive shafts. Refer to FA section ("INSTALLATION", "FRONT AXLE — Drive Shaft").

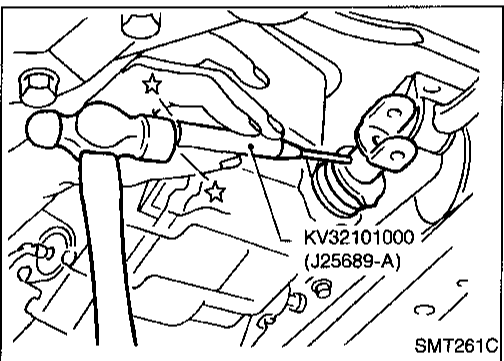

STRIKING ROD OIL SEAL

1. Remove transaxle control rod from yoke.
2. Remove yoke retaining pin with Tool.
 - **Be careful not to damage boot.**

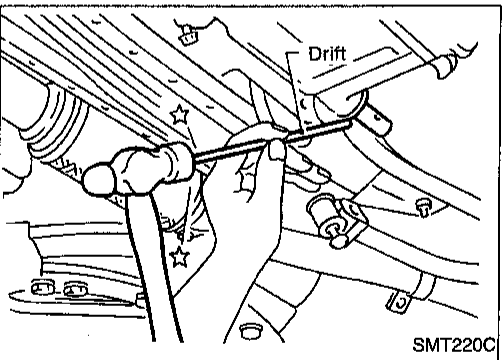

3. Remove striking rod oil seal.

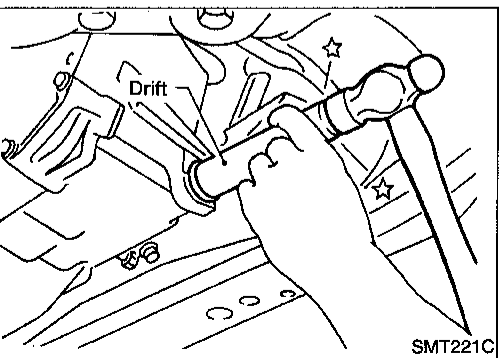

4. Install striking rod oil seal.
 - **Apply multi-purpose grease to seal lip of oil seal before installing.**

GI

MA

EM

LC

EC

FE

CL

MT

AT

FA

RA

BR

ST

RS

BT

HA

EL

IDX

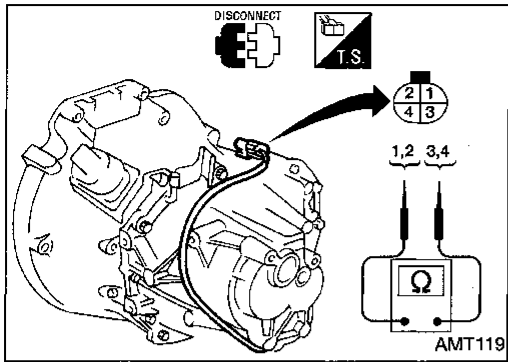

Position Switch Check

BACK-UP LAMP SWITCH AND PARK/NEUTRAL POSITION (PNP) SWITCH

- Check continuity.

Gear position	Continuity
Reverse	① — ③
Neutral	② — ④
Except reverse and neutral	No

Removal

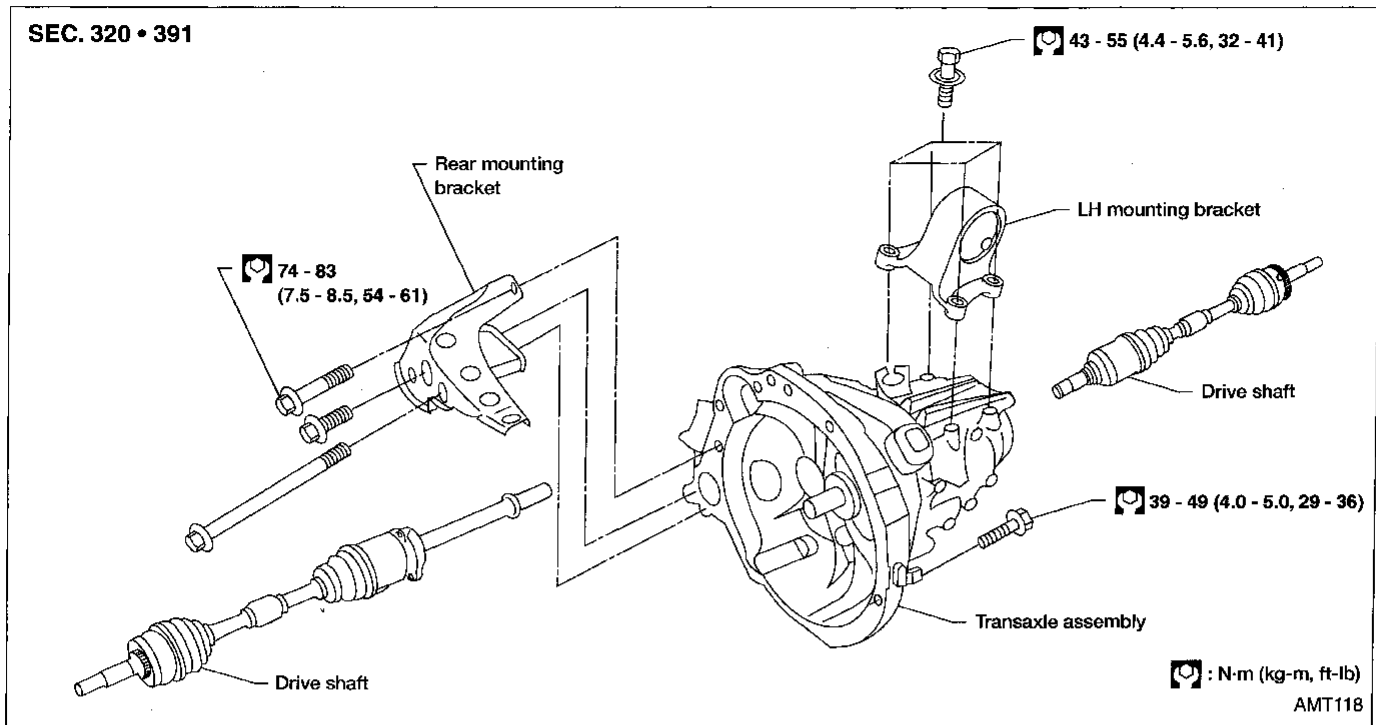

GI
MA
EM
LC
EC
FE
CL
MT

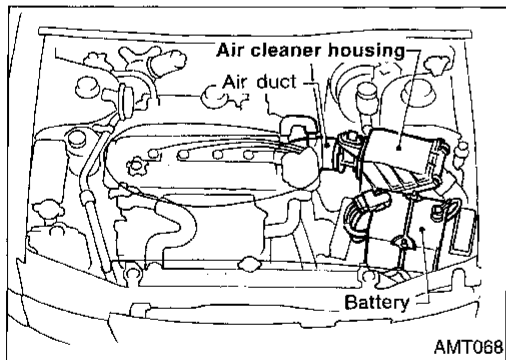

CAUTION:

Before separating transaxle from engine, remove the crankshaft position sensor (OBD) from transaxle. Be careful not to damage sensor edge or ring gear teeth.

1. Remove battery and its bracket.
2. Remove air cleaner housing with mass air flow sensor.
3. Remove air duct.

AT
FA
RA
BR

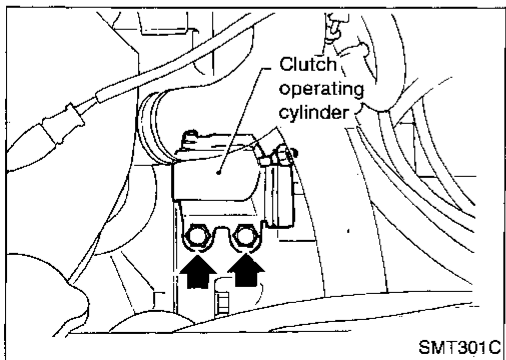

4. Remove clutch operating cylinder from transaxle.
5. Disconnect speedometer pinion, park/neutral position (PNP) switch and ground harness connectors.

HA
EL
IDX

REMOVAL AND INSTALLATION

Removal (Cont'd)

6. Remove starter motor from transaxle.

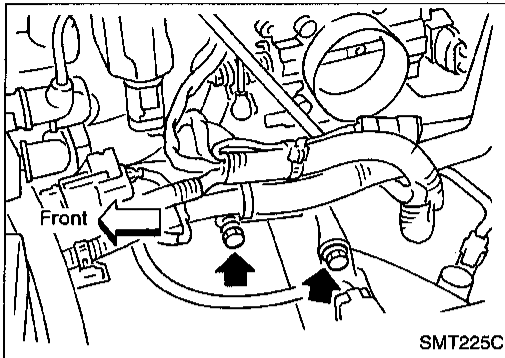

7. Remove crankshaft position sensor (OBD) from transaxle.
 - Be careful not to damage sensor tip.

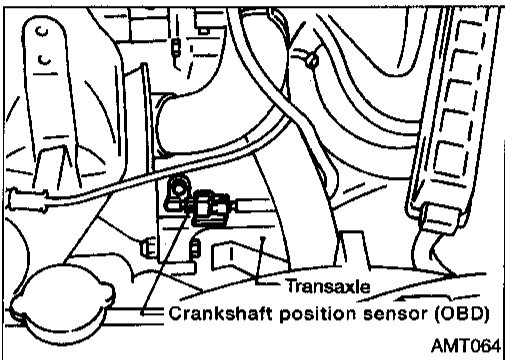

8. Remove shift control rod from transaxle.
9. Drain gear oil from transaxle.

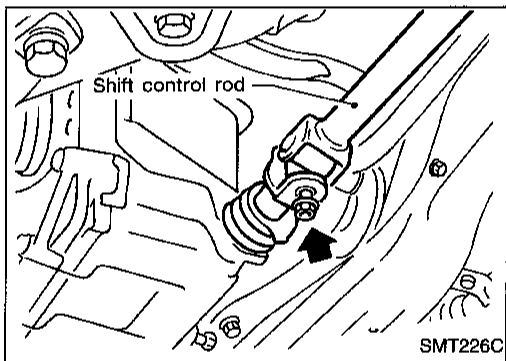

REMOVAL AND INSTALLATION

Removal (Cont'd)

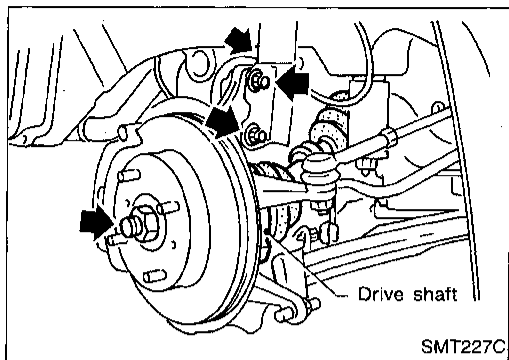

10. Draw out drive shafts from transaxle. Refer to FA section ("REMOVAL", "FRONT AXLE — Drive Shaft").

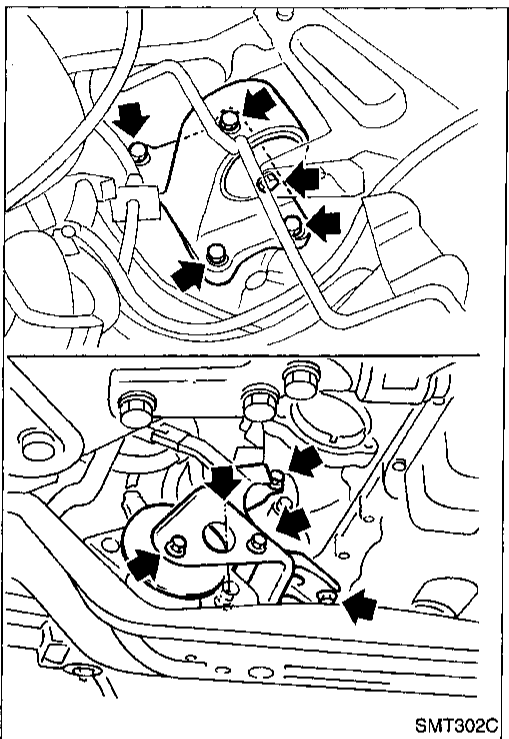

11. Support engine by placing a jack under oil pan.

CAUTION:

Do not place jack under oil pan drain plug.

12. Remove rear and LH engine mounts.

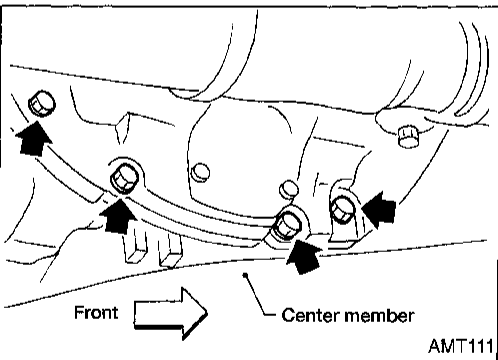

13. Raise jack for access to lower housing bolts. Remove bolts. Lower jack.

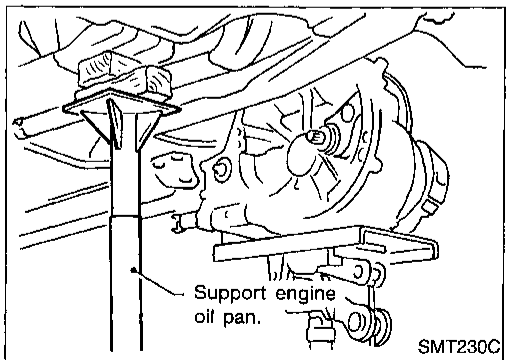

14. Remove bolts securing transaxle.

15. Lower transaxle while supporting it with a jack.

GI

MA

EM

LC

EC

FE

CL

MT

AT

FA

RA

BR

ST

RS

BT

HA

EL

IDX

REMOVAL AND INSTALLATION

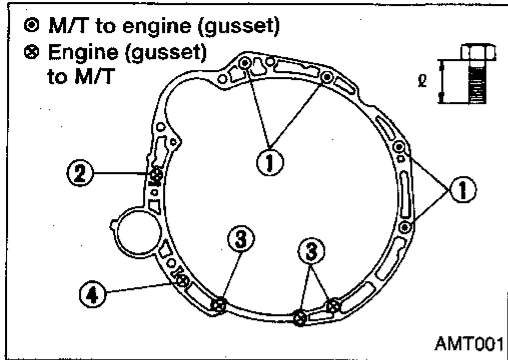

Installation

- Tighten transaxle to starter motor
 \square : 30.40 - 41.29 N·m (3.1 - 4.2 kg-m, 22.4 - 30.5 ft-lb)
- Tighten bolts securing transaxle and install any part removed.

Bolt No.	Tightening torque N·m (kg-m, ft-lb)	ℓ mm (in)
①	39 - 49 (4.0 - 5.0, 29 - 36)	45 (1.77)
②	39 - 49 (4.0 - 5.0, 29 - 36)	48 (1.89)
③	30 - 40 (3.1 - 4.1, 22 - 30)	30 (1.18)
④	30 - 40 (3.1 - 4.1, 22 - 30)	40 (1.57)

TRANSAXLE GEAR CONTROL

SEC. 341

GI

MA

EM

LC

EC

FE

CL

MT

AT

FA

RA

BR

ST

RS

BT

HA

EL

IDX

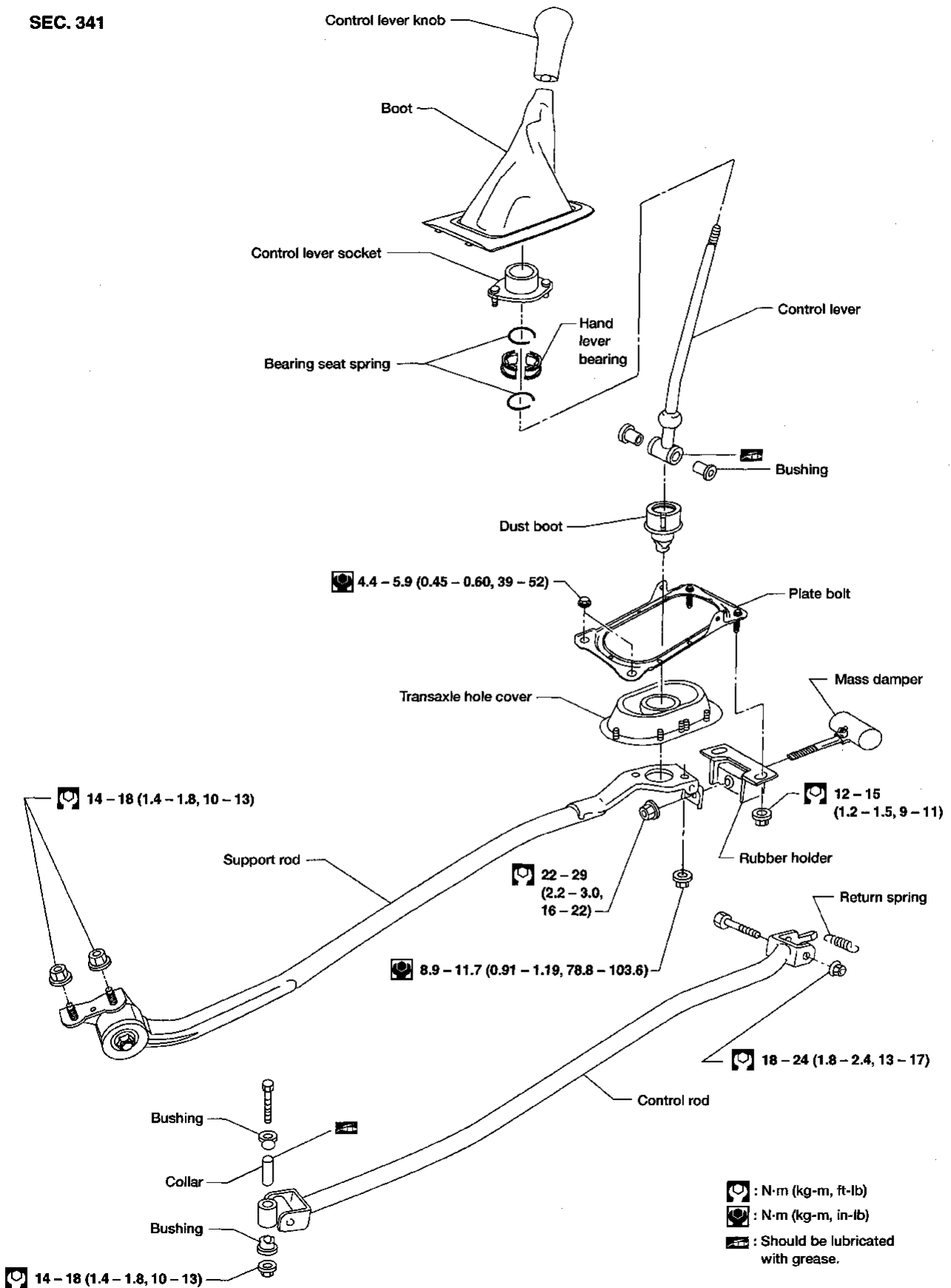

AMT117

MT-13

647

MAJOR OVERHAUL

Case Components

SEC. 320

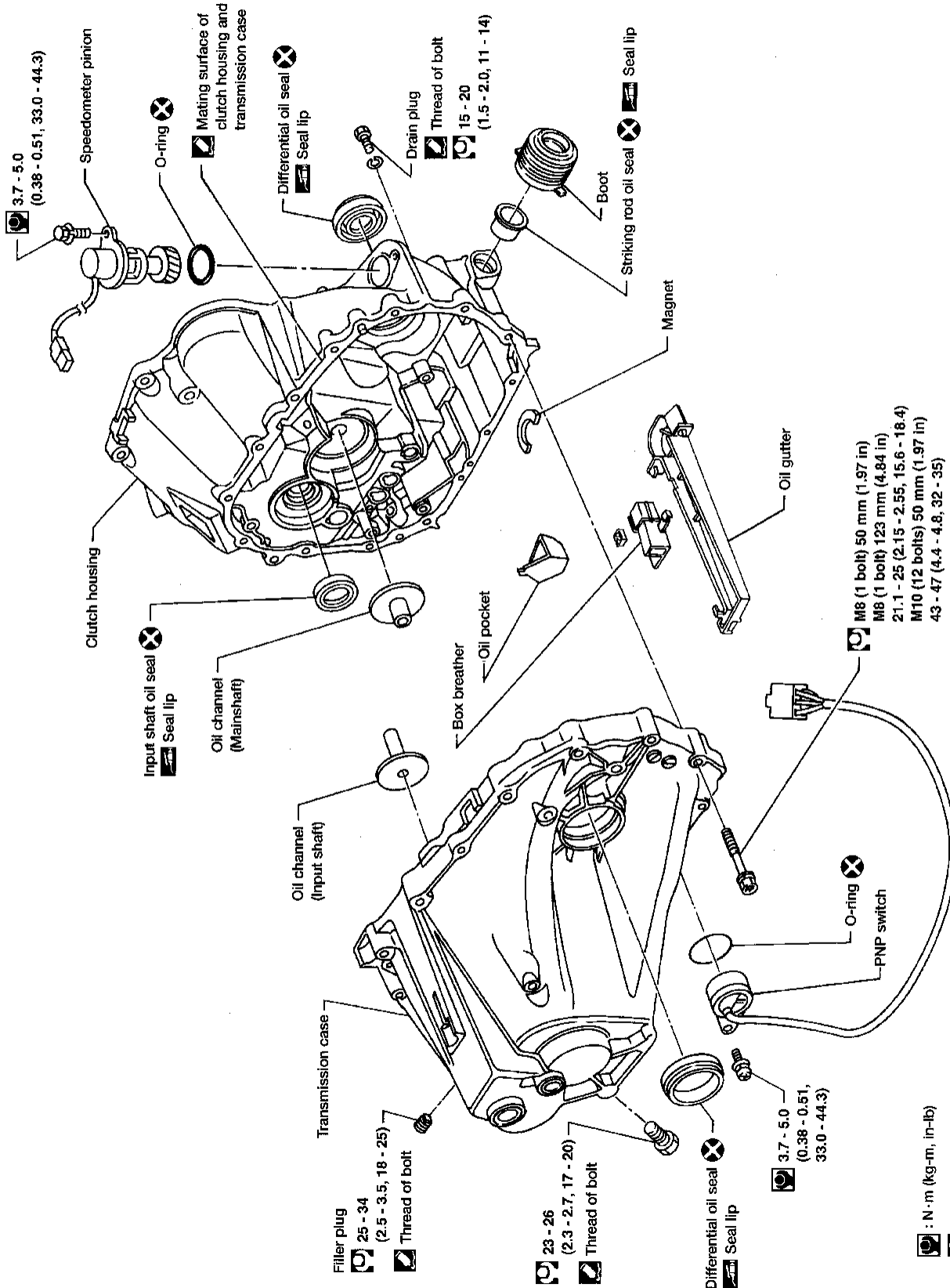

- : N·m (kg-m, in-lb)
- : N·m (kg-m, ft-lb)
- : Apply genuine anaerobic liquid gasket, Three Bond TB1215, Loctite Part No. 51813 or equivalent.

AMT148

Gear Components

SEC. 322

Apply gear oil to gears, shafts, synchronizers and bearings when assembling.

: N · m (kg-m, in-lb)

: N · m (kg-m, ft-lb)

★ : Select proper thickness.

: Apply genuine anaerobic liquid gasket, Three Bond TB1215, Loctite Part No. 51813 or equivalent.

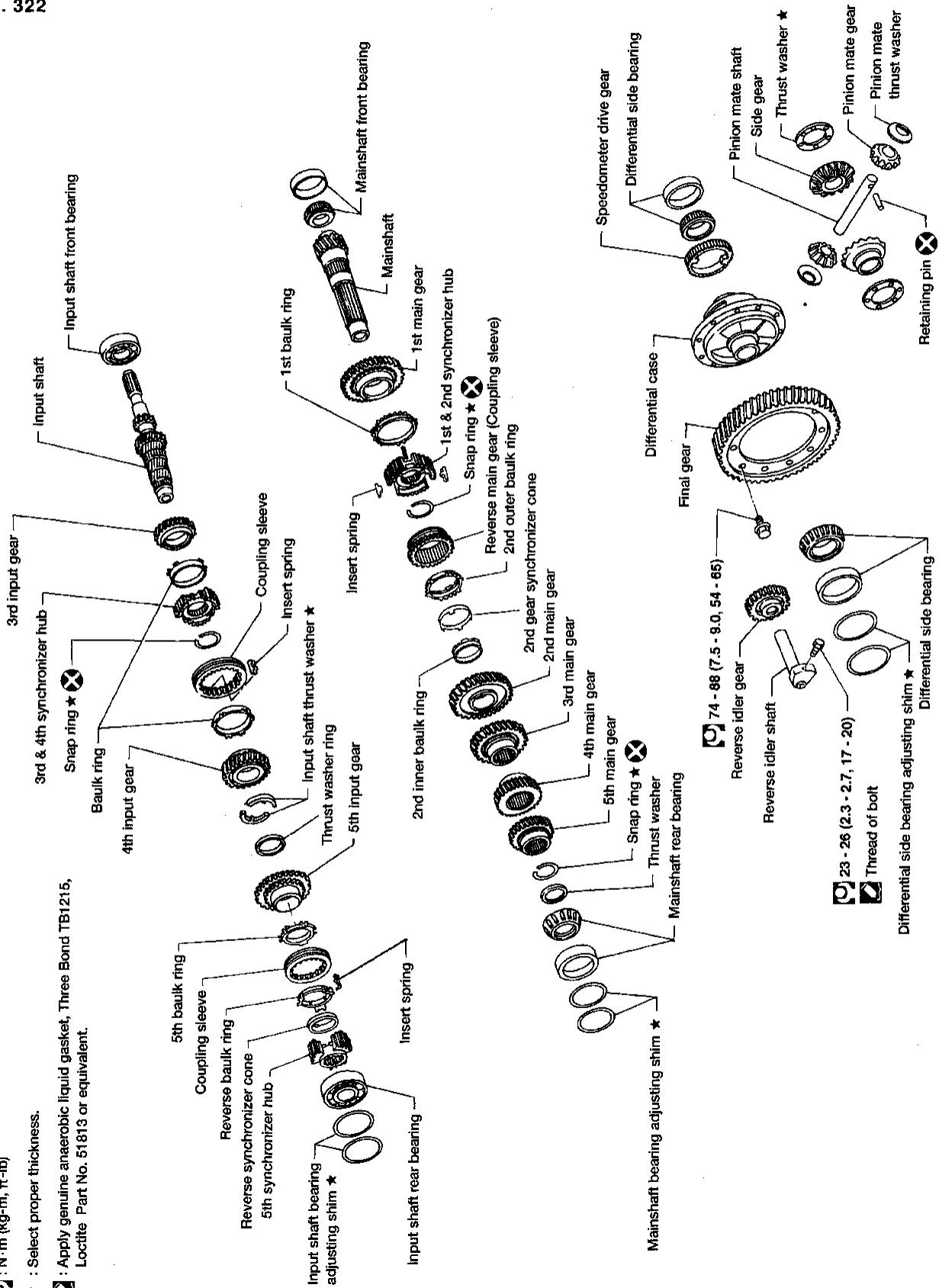

74 - 88 (7.5 - 9.0, 54 - 65)

23 - 26 (2.3 - 2.7, 17 - 20)

GI
MA
EM
LC
EC
FE
CL
MT
AT
FA
RA
BR
ST
RS
BT
HA
EL
IDX

Shift Control Components

SEC. 328

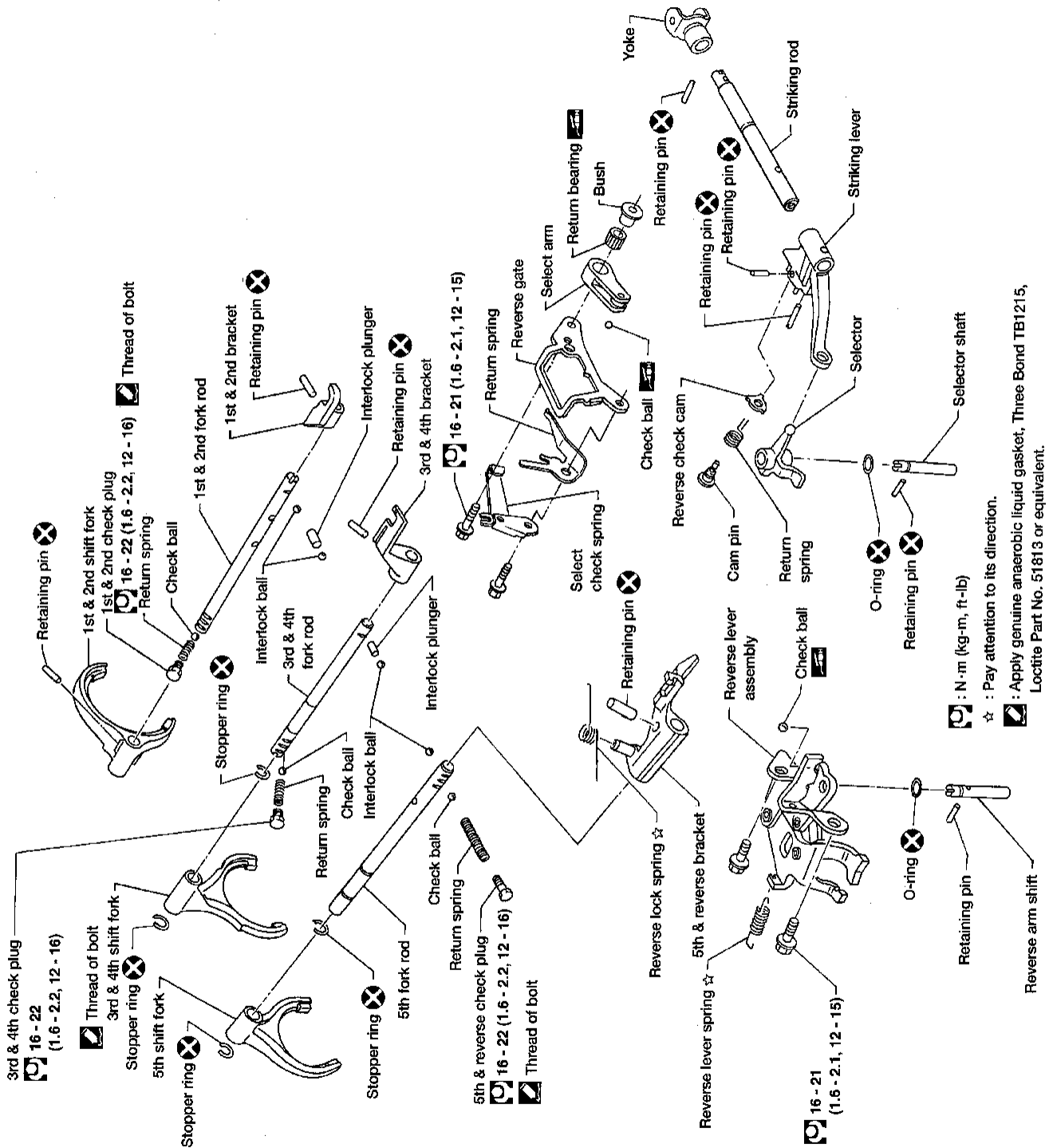

☆ : N·m (kg-m, ft-lb)
 ☆ : Pay attention to its direction.
 □ : Apply genuine anaerobic liquid gasket, Three Bond TB1215, Loctite Part No. 51813 or equivalent.

DISASSEMBLY

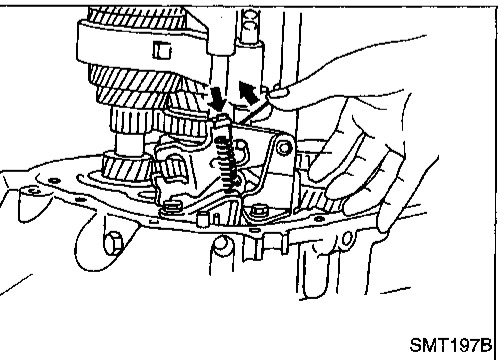
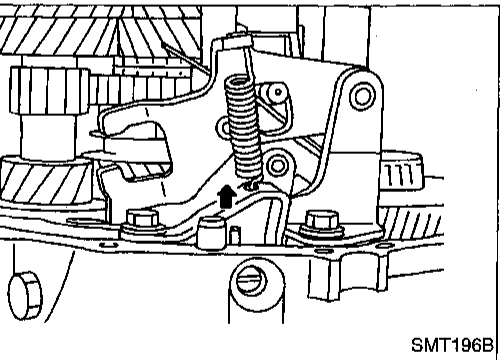
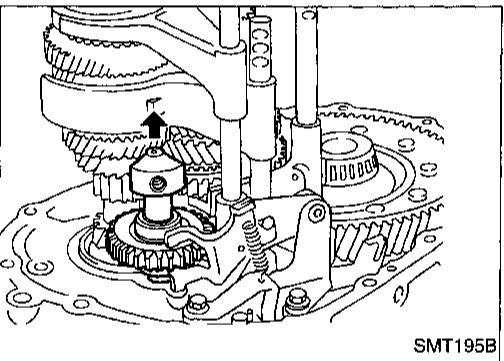
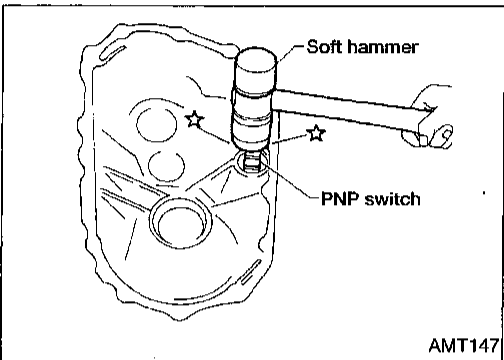
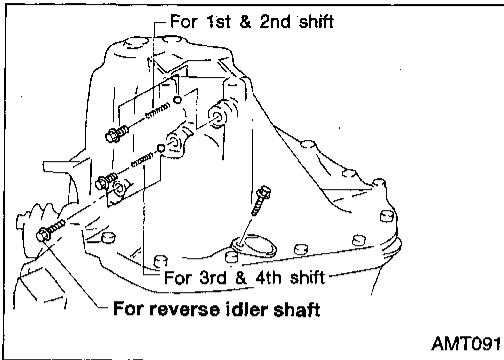

1. Before removing transmission case, remove bolts, check plugs, springs and check balls as shown left.
 - **Be careful not to lose check balls.**
2. Remove transmission case.

3. Remove park/neutral position (PNP) switch.

4. Mesh 4th gear, then remove reverse idler shaft and reverse idler gear.

5. Pull out retaining pin.

6. Remove reverse lever spring and reverse lock spring from reverse lever assembly.

GI

MA

EM

LC

EC

FE

CL

MT

AT

FA

RA

BR

ST

RS

BT

HA

EL

IDX

DISASSEMBLY

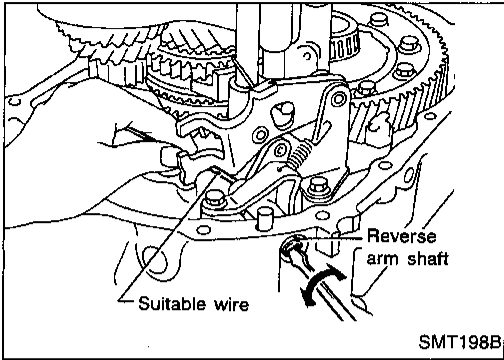

7. Remove reverse arm shaft while rotating it.

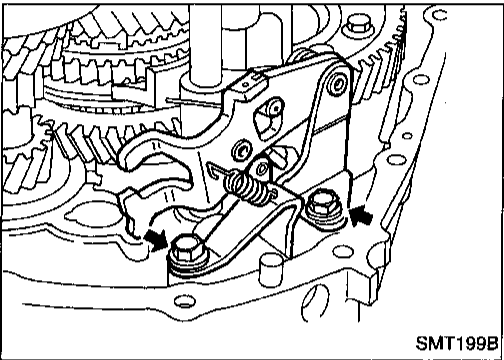

8. Remove reverse lever assembly and check ball.
● Be careful not to lose check ball.

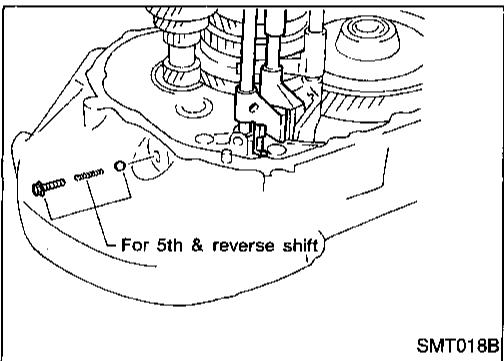

9. Remove 5th & reverse check plug, spring and ball.
● Be careful not to lose check ball.

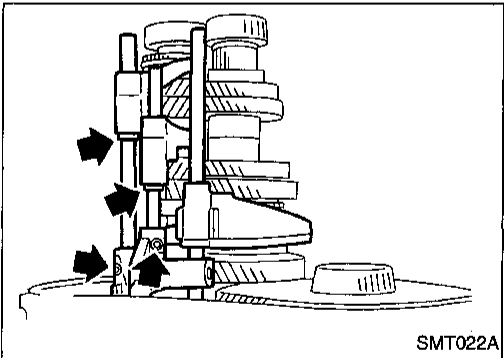

10. Remove stopper rings and retaining pins from 5th & reverse and 3rd & 4th fork rods.
11. Remove 5th & reverse and 3rd & 4th fork rods. Then remove forks and brackets.

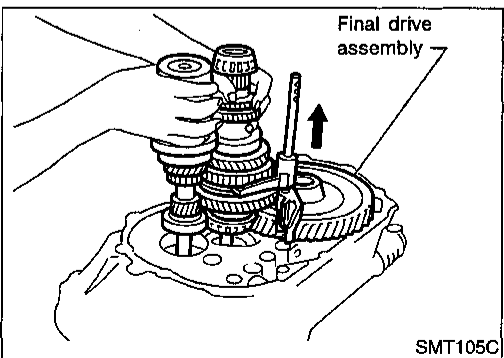

12. Remove input shaft and mainshaft with 1st & 2nd fork and fork rod as a set.
13. Remove final drive assembly.

CAUTION:

Always withdraw mainshaft straight out. Failure to do so can damage resin oil channel on clutch housing side.

DISASSEMBLY

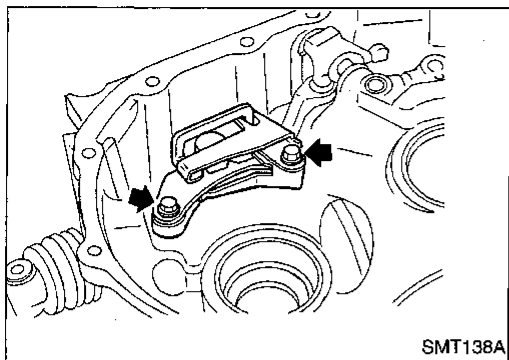

14. Remove reverse check assembly and check ball.

- **Be careful not to lose check ball.**

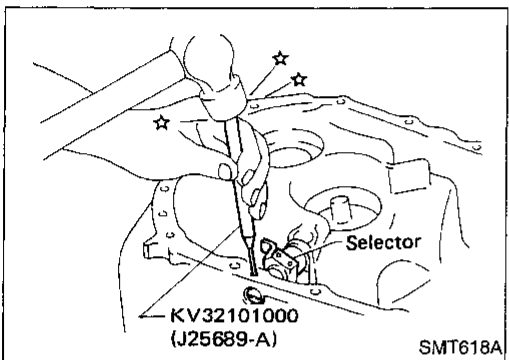

15. Remove retaining pin with Tool and detach the selector.

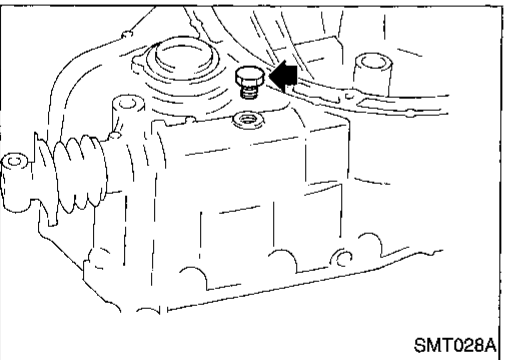
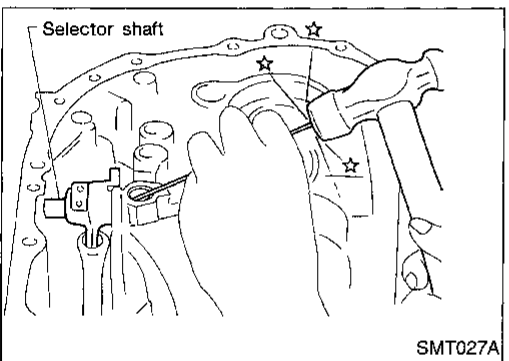

16. Remove drain plug for convenience in removing retaining pin which holds striking lever to striking rod.

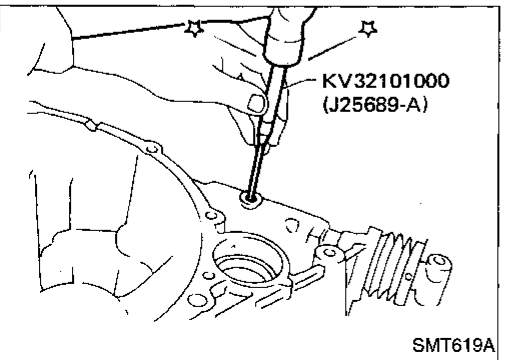

17. Remove retaining pin with Tool and then withdraw striking lever and striking rod.

GI

MA

EM

LC

EC

FE

CL

MT

AT

FA

RA

BR

ST

RS

BT

HA

EL

IDX

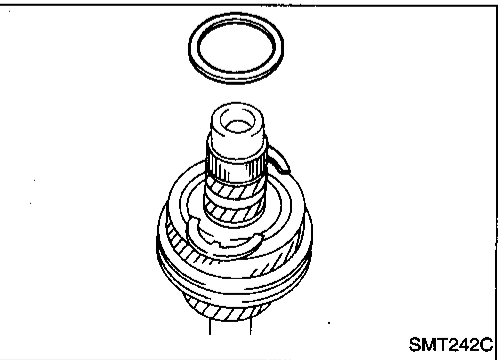
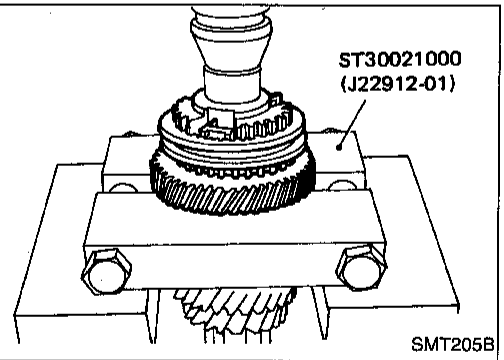
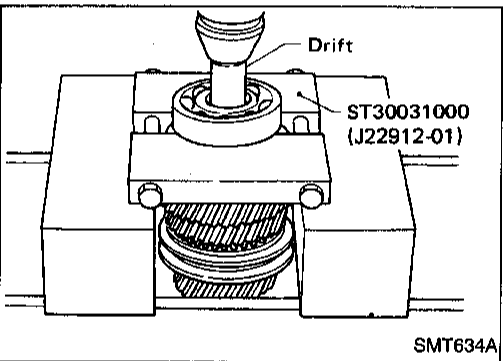
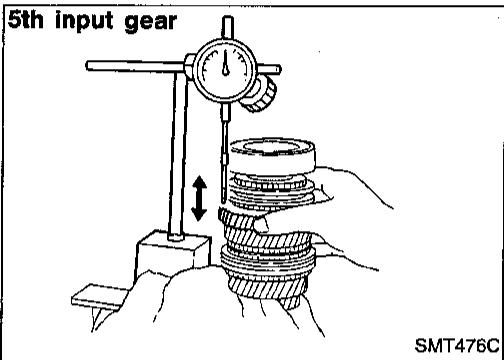
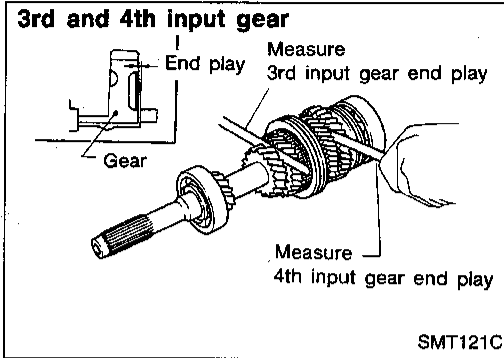

Input Shaft and Gears

DISASSEMBLY

1. Before disassembly, check 3rd, 4th and 5th input gear end plays.

Gear end play:
Refer to SDS, MT-42.

- If not within specification, disassemble and check contact surface of gear, shaft and hub. Check clearance of snap ring groove. Refer to "ASSEMBLY", MT-22.

2. Remove input shaft rear bearing with Tool.

3. Remove 5th & reverse synchronizer and 5th input gear with Tool.

4. Remove thrust washer ring, thrust washers and 4th input gear.

REPAIR FOR COMPONENT PARTS

Input Shaft and Gears (Cont'd)

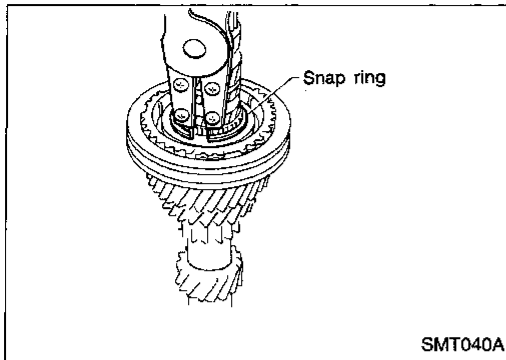

5. Remove snap ring.

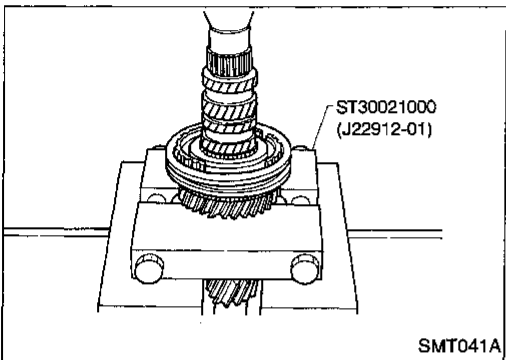

6. Remove 3rd & 4th synchronizer and 3rd input gear with Tool.

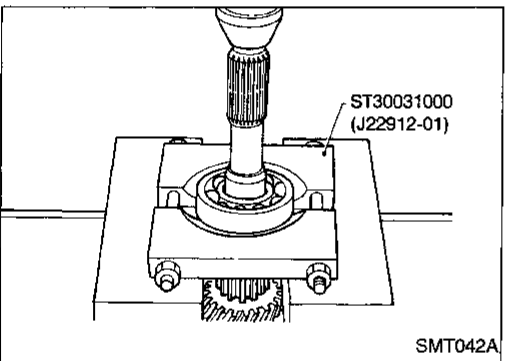

7. Remove input shaft front bearing with Tool.

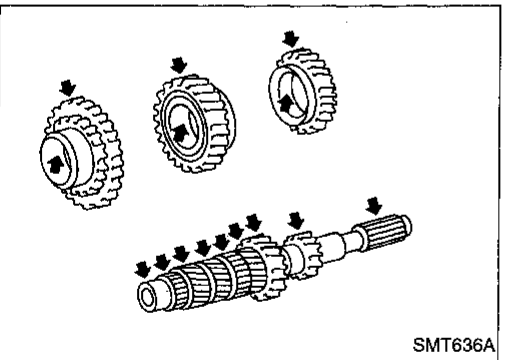

INSPECTION

Gear and shaft

- Check shaft for cracks, wear and bending.
- Check gears for excessive wear, chips and cracks.

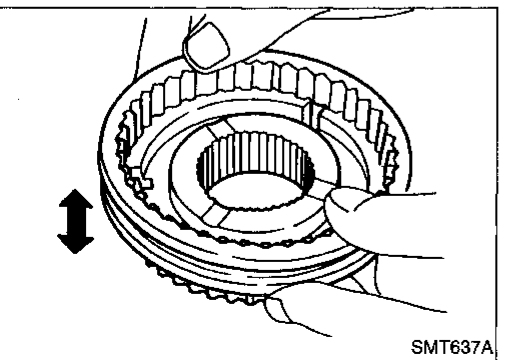

Synchronizer

- Check spline portion of coupling sleeves, hubs and gears for wear or cracks.
- Check baulk rings for cracks and deformation.
- Check insert springs for wear and deformation.

GI

MA

EM

LC

EC

FE

CL

MT

AT

FA

RA

BR

ST

RS

BT

HA

EL

IDX

REPAIR FOR COMPONENT PARTS

Input Shaft and Gears (Cont'd)

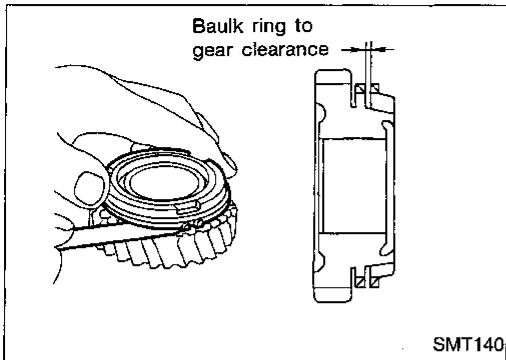

- Measure clearance between baulk ring and gear (3rd, 4th and 5th).

**Clearance between baulk ring and gear:
Refer to SDS, MT-42.**

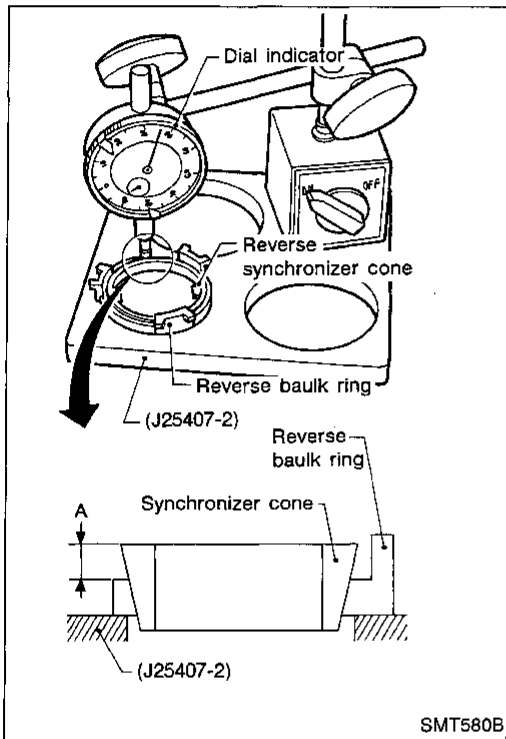

- **Measure wear of reverse baulk ring.**
 - a. Place reverse baulk ring on Tool and then place reverse synchronizer cone on reverse baulk ring.
- **Make sure projection of synchronizer cone is positioned over the recess on Tool.**
 - b. While holding reverse synchronizer cone against reverse baulk ring as firmly as possible, measure dimension "A" with dial indicator.

Wear limit (Dimension "A"):

Refer to SDS, MT-42.

- c. If dimension "A" is smaller than the wear limit, replace baulk ring.

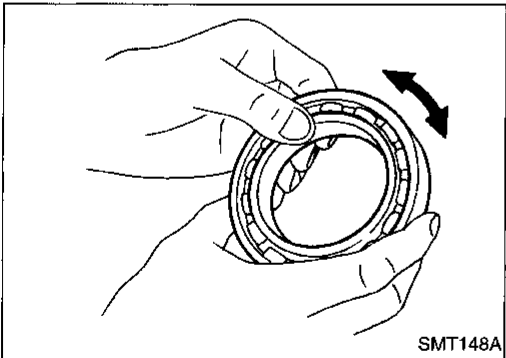

Bearing

- Make sure bearings roll freely and are free from noise, cracks, pitting and wear.

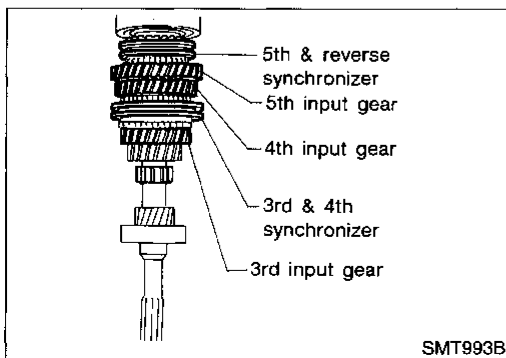

ASSEMBLY

REPAIR FOR COMPONENT PARTS

Input Shaft and Gears (Cont'd)

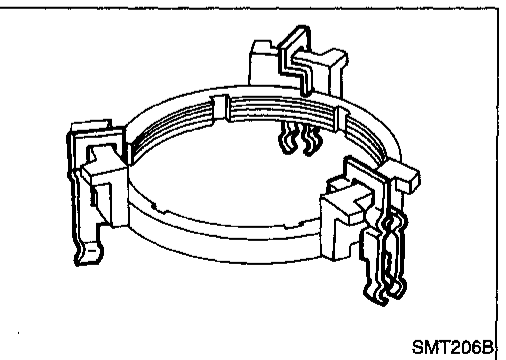
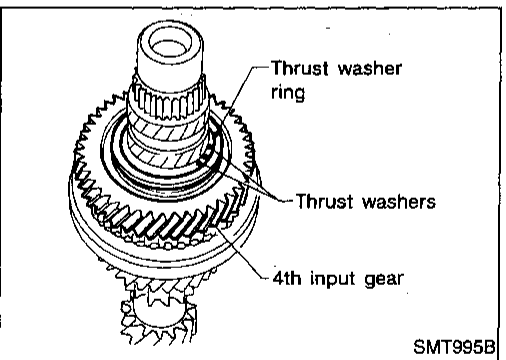
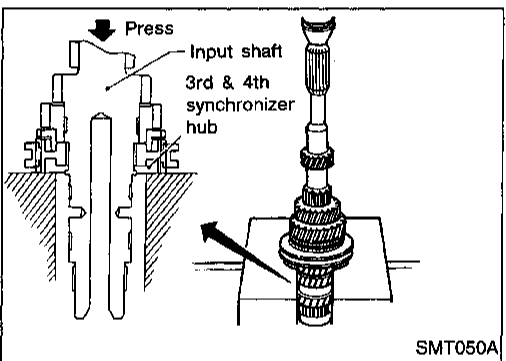
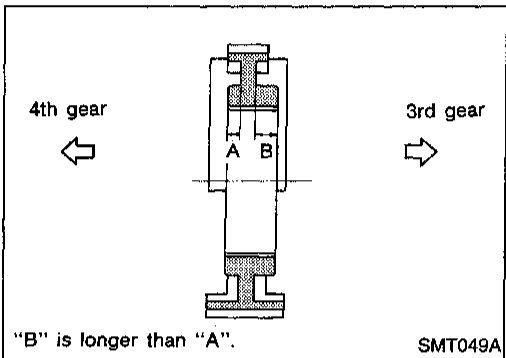
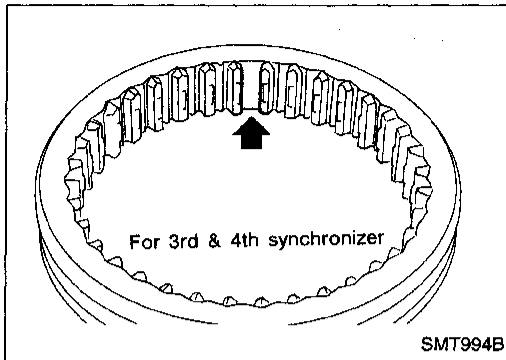

1. Place inserts in three grooves on coupling sleeve (3rd & 4th synchronizer).

2. Install 3rd input gear and 3rd baulk ring.
3. Press on 3rd & 4th synchronizer hub.
- **Pay attention to its direction.**
4. Select proper snap ring of 3rd & 4th synchronizer hub to minimize clearance of groove, and then install it.

Allowable clearance of groove:

0 - 0.1 mm (0 - 0.004 in)

Snap ring of 3rd & 4th synchronizer hub:

Refer to SDS, MT-42.

5. Install 4th input gear.
6. Select proper thrust washers to minimize clearance of groove.

Then install them and thrust washer ring.

Allowable clearance of groove:

0 - 0.06 mm (0 - 0.0024 in)

Input shaft thrust washer:

Refer to SDS, MT-43.

7. Install 5th & reverse synchronizer assembly.
 - a. Hook insert springs on reverse baulk ring.

GI

MA

EM

LC

EC

FE

CL

MT

AT

FA

RA

BR

ST

RS

BT

HA

EL

IDX

REPAIR FOR COMPONENT PARTS

Input Shaft and Gears (Cont'd)

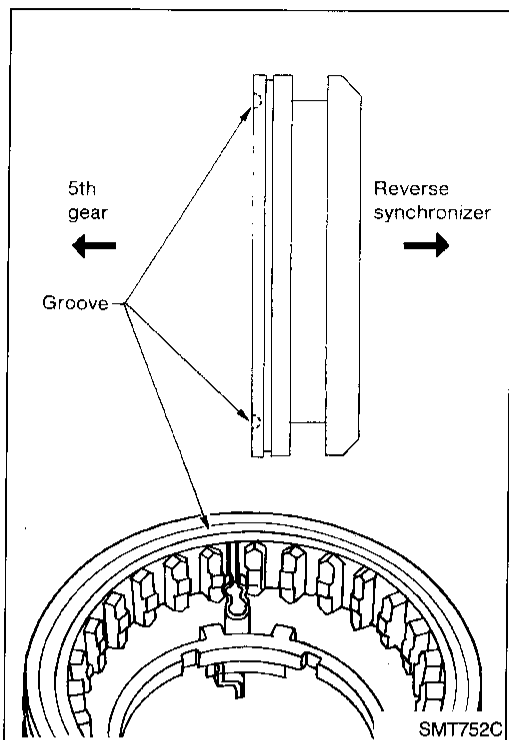

- b. Install insert springs with reverse baulk ring onto coupling sleeve.
- **Pay attention to position of insert springs.**
- c. Place 5th baulk ring on 5th input gear.
- d. Install reverse synchronizer cone on reverse baulk ring.

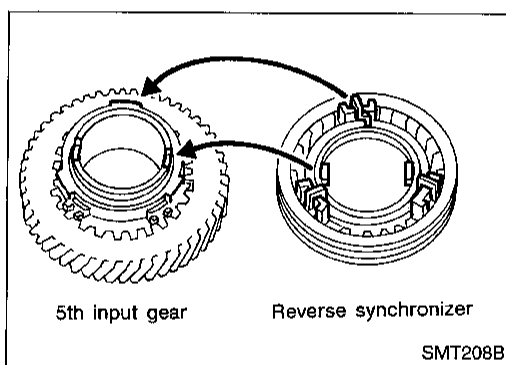

- e. Place reverse synchronizer assembly on 5th input gear.
- **Mesh recesses of 5th input gear with projections of reverse synchronizer cone.**
- **Put insert spring mounts on reverse baulk ring upon those on 5th baulk ring.**

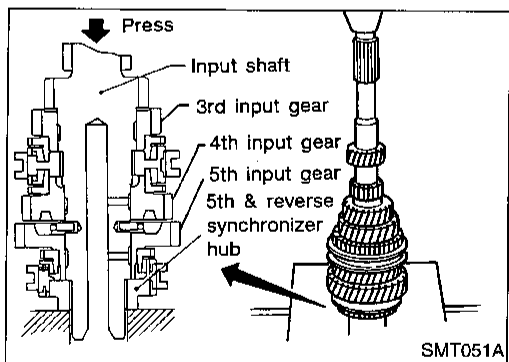

- f. Press on 5th & reverse synchronizer assembly with 5th input gear.

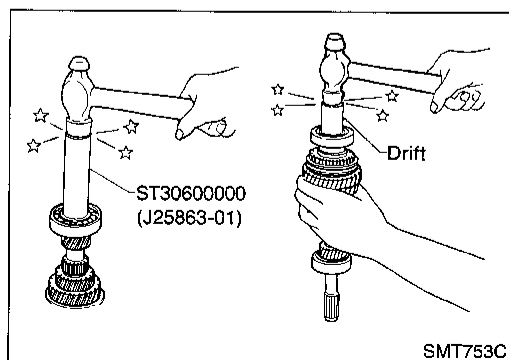

8. Install input shaft front and rear bearings with Tool.
9. Measure gear end play as the final check. Refer to "DISASSEMBLY" MT-20.

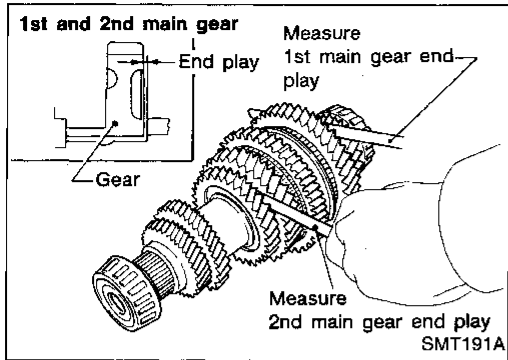

Mainshaft and Gears

DISASSEMBLY

1. Before disassembly, check 1st and 2nd main gear end plays.

Gear end play:
Refer to SDS, MT-42.

- If not within specification, disassemble and check contact surface of gear, shaft and hub. Then check clearance of snap ring groove. Refer to "ASSEMBLY", MT-27.

2. Press out mainshaft rear bearing with Tool.

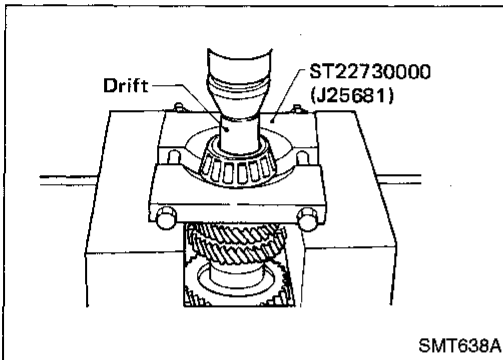

3. Remove thrust washer and snap ring.

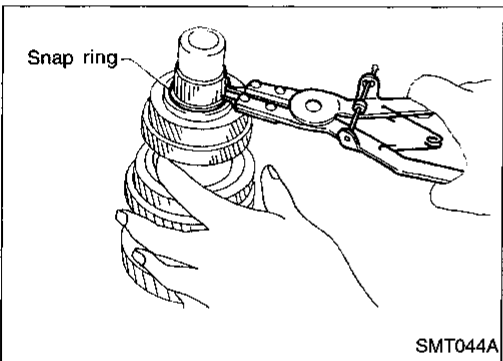

4. Press out 5th main gear and 4th main gear with Tool.

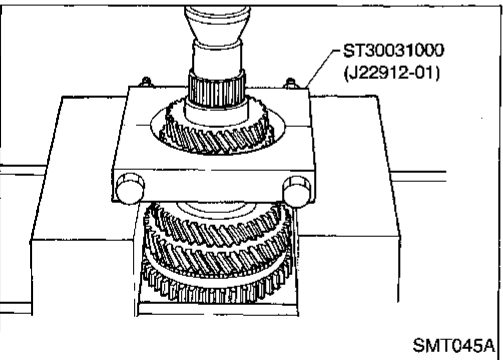

5. Press out 3rd main gear and 2nd main gear with Tool.

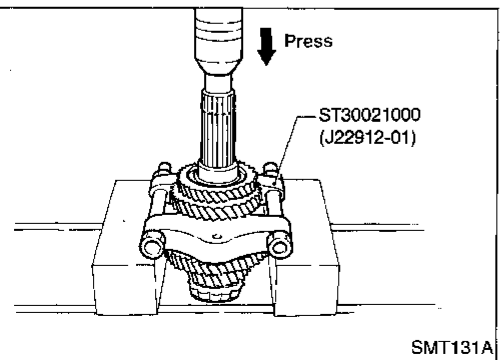

GI

MA

EM

LC

EC

FE

CL

MT

AT

FA

RA

BR

ST

RS

BT

HA

EL

IDX

REPAIR FOR COMPONENT PARTS

Mainshaft and Gears (Cont'd)

6. Remove snap ring.

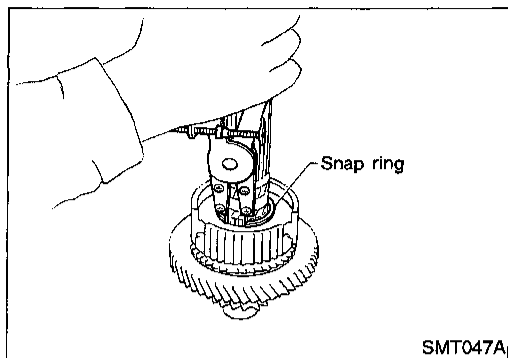

7. Remove 1st & 2nd synchronizer and 1st main gear.

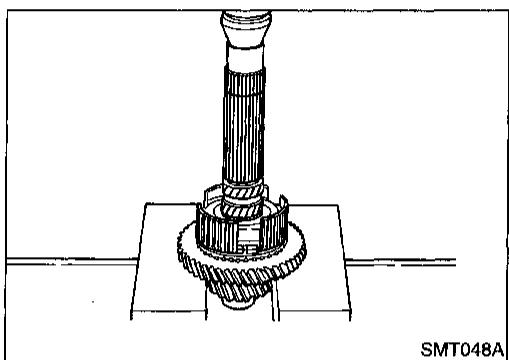

8. Remove mainshaft front bearing with Tool.

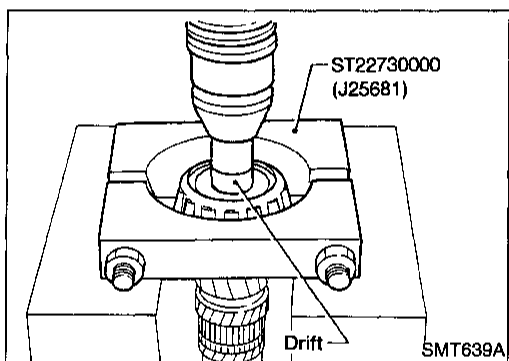

INSPECTION

Gear and shaft

- Check shaft for cracks, wear and bending.
- Check gears for excessive wear, chips and cracks.

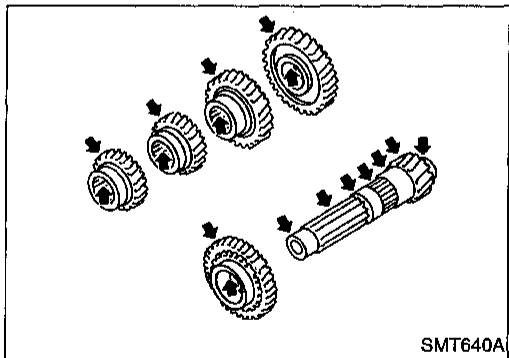

Synchronizer

- Check spline portion of coupling sleeves, hubs and gears for wear and cracks.
- Check baulk rings for cracks and deformation.
- Check insert springs for deformation.

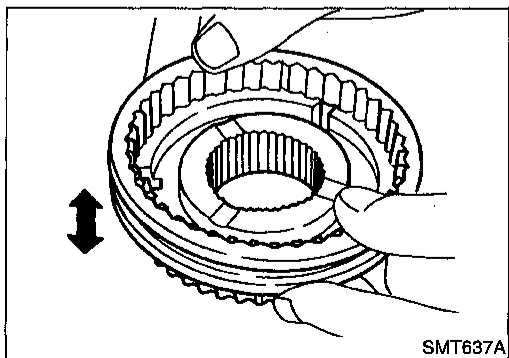

REPAIR FOR COMPONENT PARTS

Mainshaft and Gears (Cont'd)

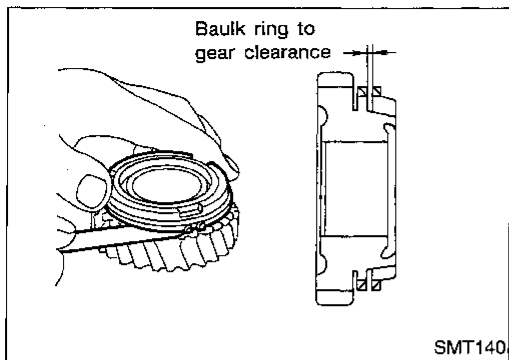

- Measure clearance between baulk ring and gear (1st).
Clearance between baulk ring and gear:
Refer to SDS, MT-42.

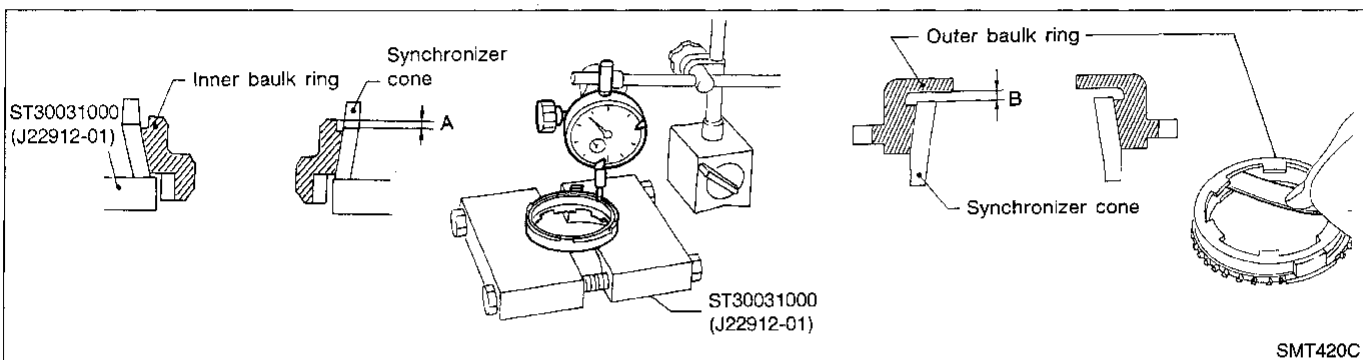

- Measure wear of 2nd baulk rings.
 - a. Place baulk rings in position on synchronizer cone.
 - b. While holding baulk ring against synchronizer cone as far as it will go, measure dimensions "A" and "B".
Standard and wear limit:
Refer to SDS, MT-42.
 - c. If dimension "A" or "B" is smaller than the wear limit, replace baulk ring.

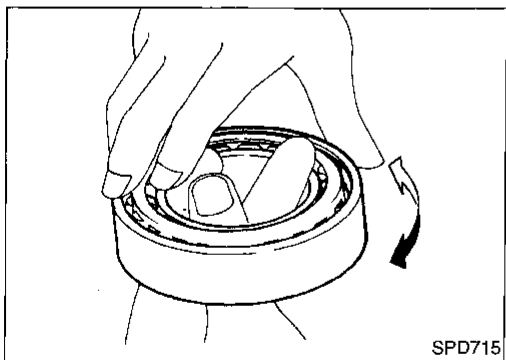

Bearing

- Make sure bearings roll freely and are free from noise, cracks, pitting and wear.
- **When replacing tapered roller bearing, replace outer and inner race as a set.**

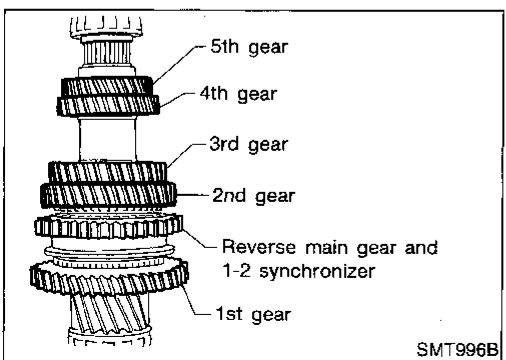

ASSEMBLY

REPAIR FOR COMPONENT PARTS

Mainshaft and Gears (Cont'd)

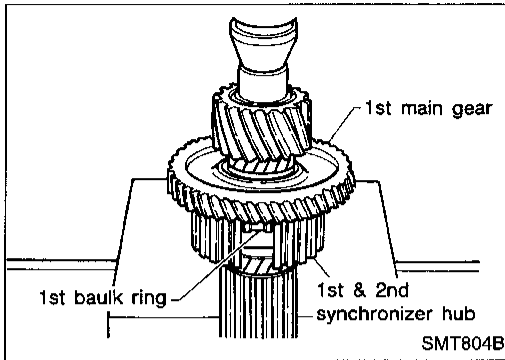

1. Press on 1st main gear, 1st baulk ring and 1st & 2nd synchronizer hub.
 - Pay attention to direction of 1st & 2nd synchronizer hub.

2. Select proper snap ring of 1st & 2nd synchronizer hub to minimize clearance of groove and then install it.

Allowable clearance of groove:

0 - 0.1 mm (0 - 0.004 in)

Snap ring of 1st & 2nd synchronizer hub:

Refer to SDS, MT-42.

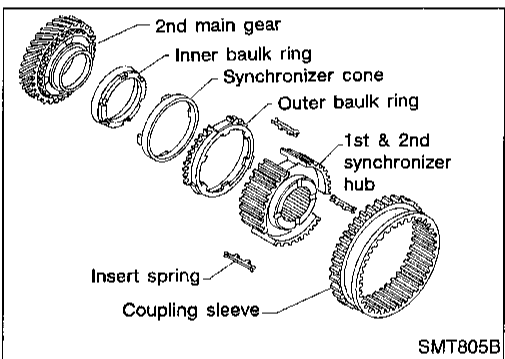
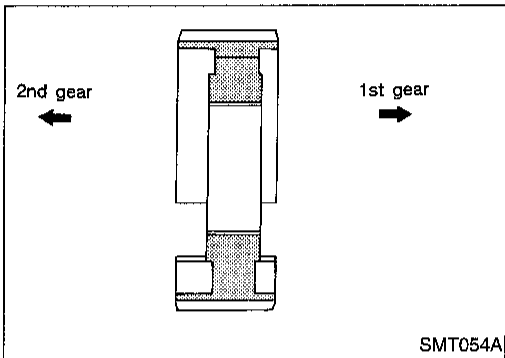

3. Install 2nd synchronizer cone, inner & outer baulk rings. Insert springs and 1st & 2nd coupling sleeve.
4. Install 2nd main gear.
 - Ensure four protrusions of 2nd synchronizer cone are set in 2nd main gear holes.

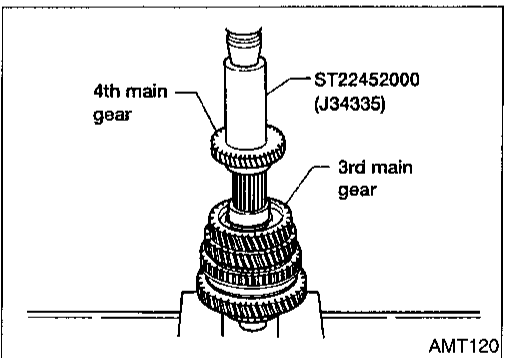

5. Use Tool to press on 3rd main gear.
6. Use Tool to press on 4th main gear.

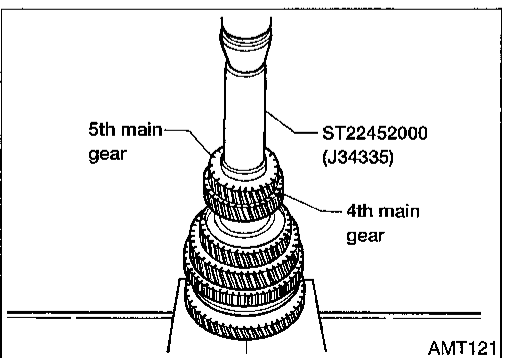

7. Use Tool to press on 5th main gear.
8. Select proper snap ring of 5th main gear to minimize clearance of groove and then install it.

Allowable clearance of groove:

0 - 0.15 mm (0 - 0.0059 in)

Snap ring of 5th main gear:

Refer to SDS, MT-42.

REPAIR FOR COMPONENT PARTS

Mainshaft and Gears (Cont'd)

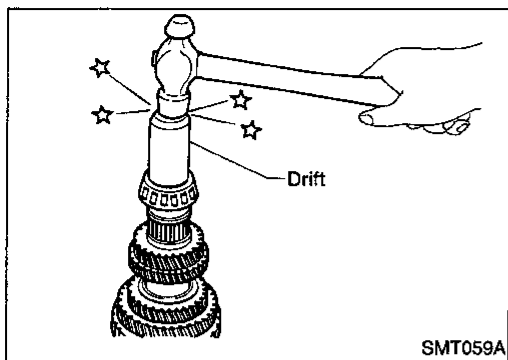

9. Press on thrust washer and press on mainshaft rear bearing.

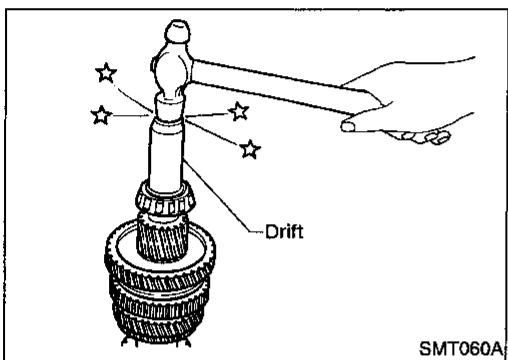

10. Press on mainshaft front bearing.
11. Measure gear end play as the final check. Refer to "DISASSEMBLY" MT-25.

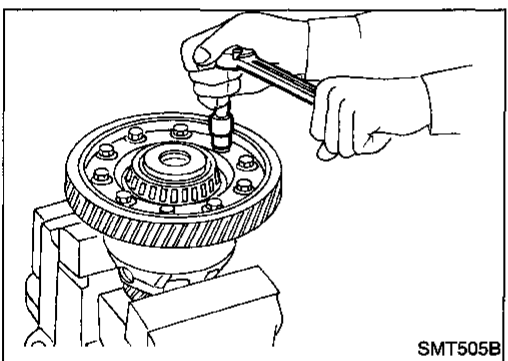

Final Drive

DISASSEMBLY

1. Remove final gear.
2. Remove speedometer drive gear by cutting it.

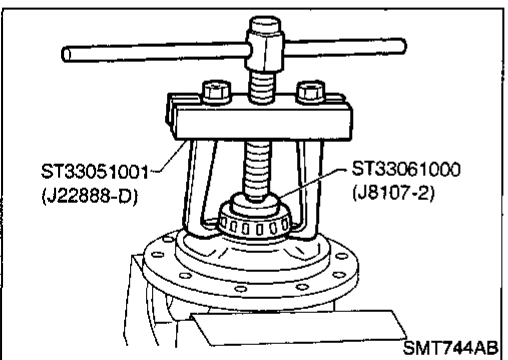

3. Press out differential side bearings with Tool.
 - Be careful not to mix up the right and left bearings.

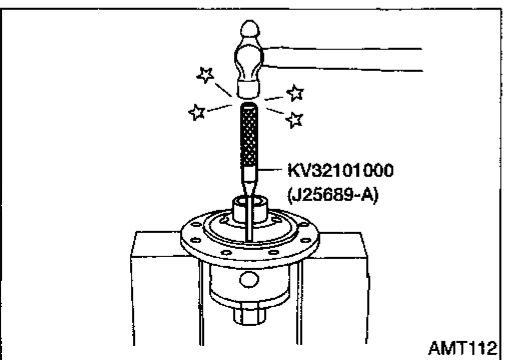

4. Drive out retaining pin and draw out pinion mate shaft.
5. Remove pinion mate gears and side gears.

GI

MA

EM

LC

EC

FE

CL

MT

AT

FA

RA

BR

ST

RS

BT

HA

EL

IDX

REPAIR FOR COMPONENT PARTS

Final Drive (Cont'd)

INSPECTION

Gear, washer, shaft and case

- Check mating surfaces of differential case, side gears and pinion mate gears.
- Check washers for wear.

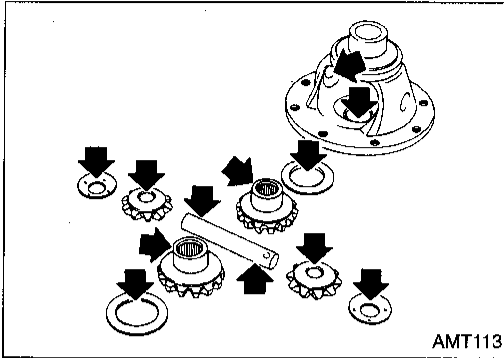

Bearing

- Make sure bearings roll freely and are free from noise, cracks, pitting and wear.
- **When replacing tapered roller bearing, replace outer and inner race as a set.**

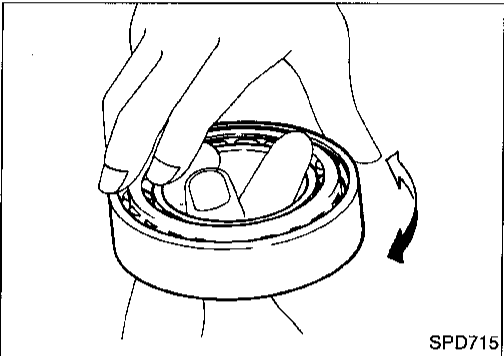

ASSEMBLY

1. Install side gear and thrust washers in differential case.
2. Install pinion mate gears and thrust washers in differential case while rotating them.
 - **When inserting, be careful not to damage pinion mate thrust washers.**
 - **Apply gear oil to gears, shafts, synchronizers and bearings when assembling.**

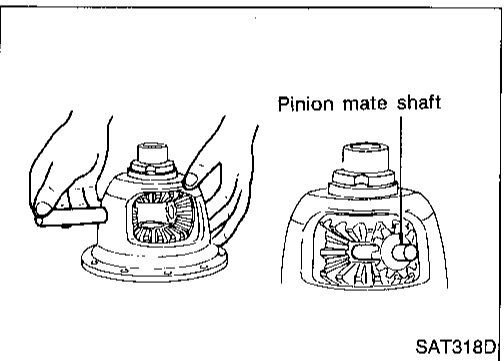

3. Measure clearance between side gear and differential case with washers following the procedure below:
 - a. Set Tool and dial indicator on side gear.
 - b. Move side gear up and down to measure dial indicator deflection. Always measure indicator deflection on both side gears.

Clearance between side gear and differential case with washers:

0.1 - 0.2 mm (0.004 - 0.008 in)

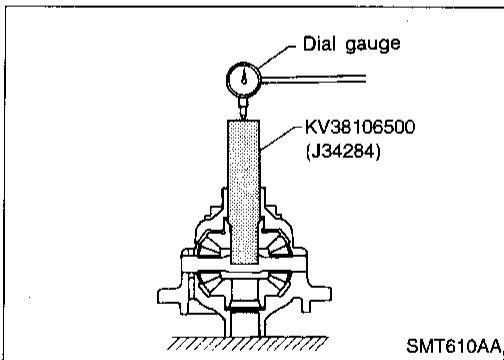

REPAIR FOR COMPONENT PARTS

Final Drive (Cont'd)

- c. If not within specification, adjust clearance by changing thickness of side gear thrust washers.

**Side gear thrust washer:
Refer to SDS, MT-43.**

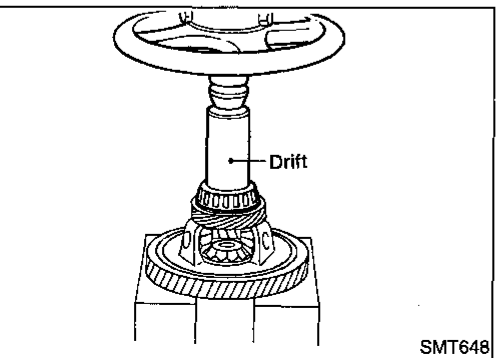
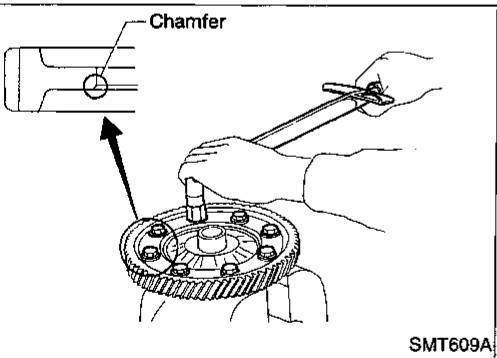
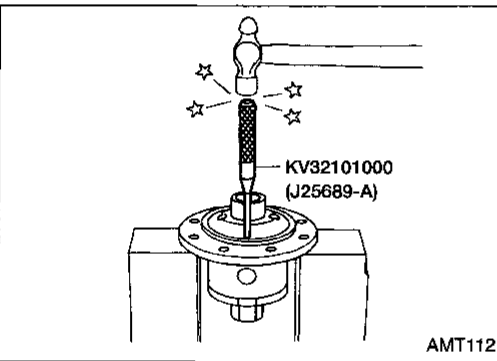
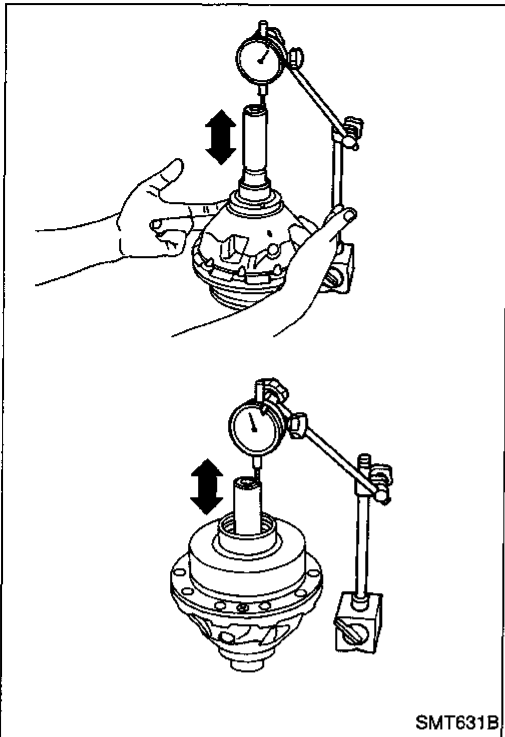

4. Install retaining pin.
● **Make sure that retaining pin is flush with case.**

6. Install final gear.
● **Apply locking sealant to final gear fixing bolts before installing.**
7. Install speedometer drive gear.

8. Press on differential side bearings.

GI

MA

EM

LC

EC

FE

CL

MT

AT

FA

RA

BR

ST

RS

BT

HA

EL

IDX

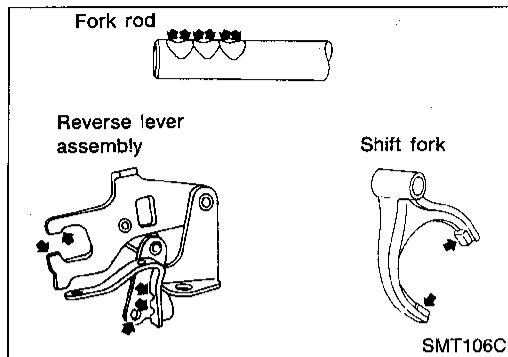

Shift Control Components

INSPECTION

- Check contact surface and sliding surface for wear, scratches, projections and other damage.

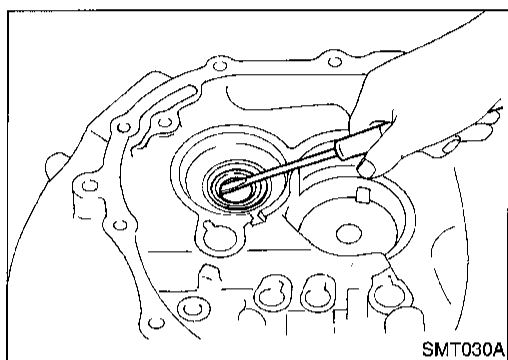

Case Components

REMOVAL AND INSTALLATION

Input shaft oil seal

- Apply multi-purpose grease to seal lip of oil seal before installing.

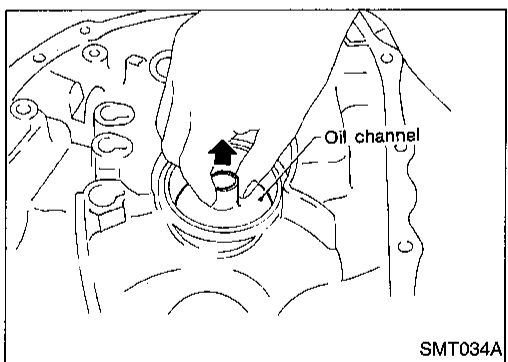
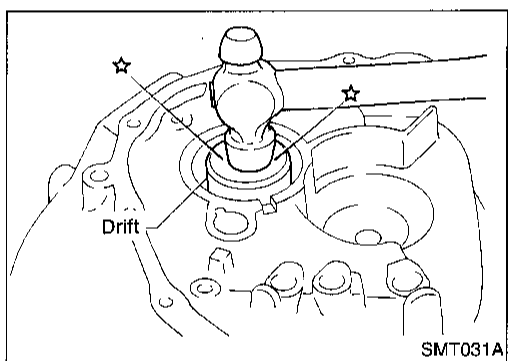

Mainshaft front bearing outer race

- Pull out oil channel (mainshaft) to remove front bearing outer race.

Mainshaft rear bearing outer race

Refer to MT-34.

Differential side bearing outer race

Refer to MT-33.

ADJUSTMENT

Input Shaft End Play and Differential Side Bearing Preload

If any of the following parts are replaced, adjust input shaft end play.

- Input shaft
- Input shaft bearing
- Clutch housing
- Transmission case

If any of the following parts are replaced, adjust differential side bearing preload.

- Differential case
- Differential side bearing
- Clutch housing
- Transmission case

GI

MA

EM

LC

EC

FE

CL

MT

AT

FA

RA

BR

ST

RS

BT

HA

EL

IDX

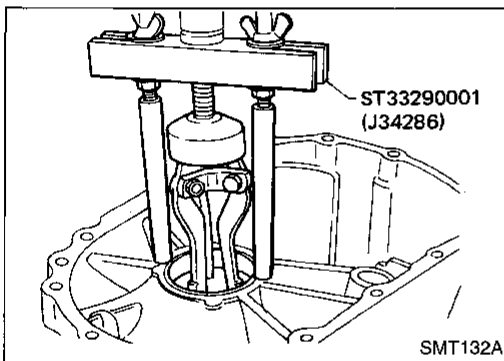

1. Remove differential side bearing outer race (transmission case side) and shim(s).

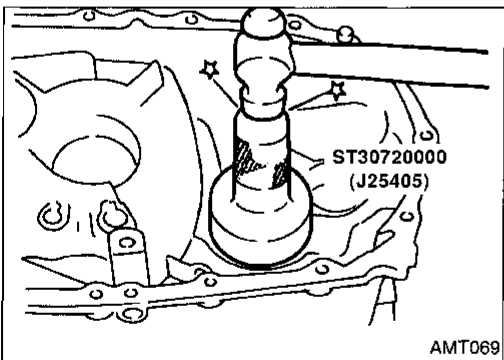

2. Install differential side bearing outer race without shim(s).
3. Install input shaft and final drive assembly on clutch housing.
4. Install transmission case without input shaft bearing shim(s). Tighten it to the specified torque. Refer to MT-14.

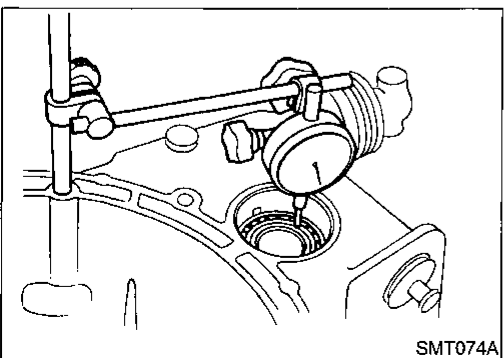

5. Using the following procedures, measure clearance between bearings and transmission case.
 - Differential side
 - a. Attach dial indicator. If clamp diameter of dial indicator is too small or too large, attach dial indicator using a magnetic stand.

ADJUSTMENT

Input Shaft End Play and Differential Side Bearing Preload (Cont'd)

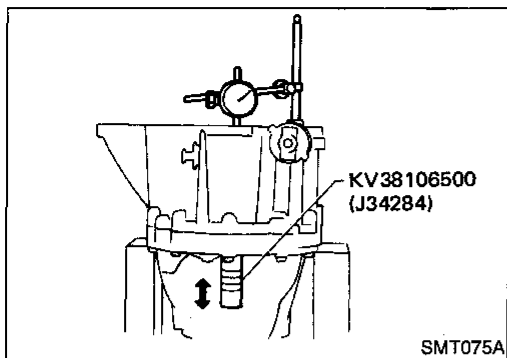

- b. Insert Tool all the way into differential side gear. Move Tool up and down and measure dial indicator deflection.

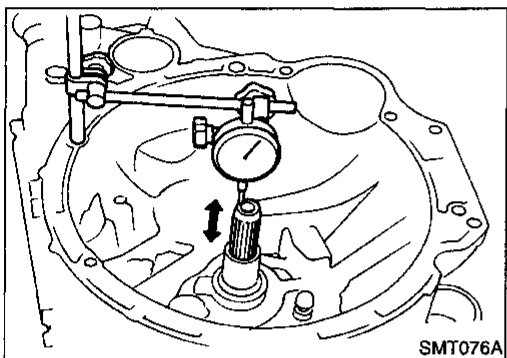

- **Input shaft side**
 - a. Set dial indicator on rear end of input shaft.
 - b. Move input shaft up and down and measure dial indicator deflection.
- 6. Select shims with proper thickness with SDS table as a guide. Refer to MT-44.
- 7. Install selected differential side bearing adjusting shim and differential side bearing outer race.

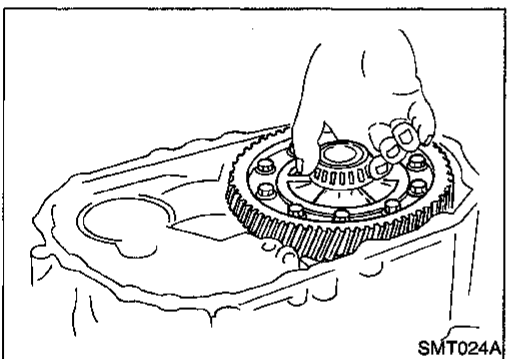

8. Check differential side bearing turning torque.
 - a. Install final drive assembly on clutch housing.
 - b. Install transmission case on clutch housing.
- **Tighten transmission case fixing bolts to the specified torque.**

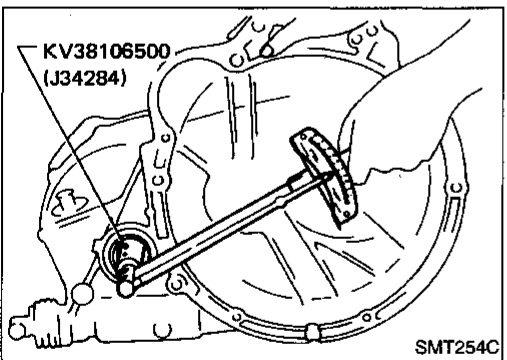

- c. Measure turning torque of final drive assembly.

Turning torque of final drive assembly (New bearing):
4.9 - 7.8 N·m (50 - 80 kg·cm, 43 - 69 in·lb)

 - When old bearing is used again, turning torque will be slightly less than the above.
 - Make sure torque is close to the specified range.

Mainshaft Bearing Preload

If any of the following parts are replaced, adjust mainshaft bearing preload.

- **Mainshaft**
- **Mainshaft bearings**
- **Clutch housing**
- **Transmission case**

ADJUSTMENT

Mainshaft Bearing Preload (Cont'd)

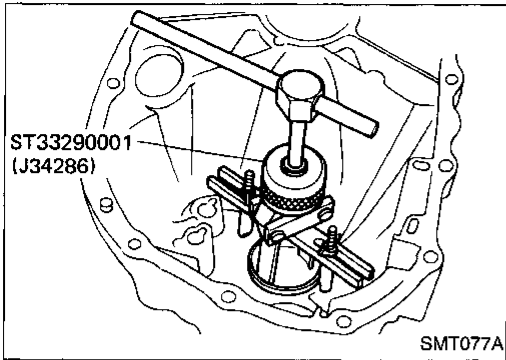

1. Remove mainshaft rear bearing outer race and shim(s).

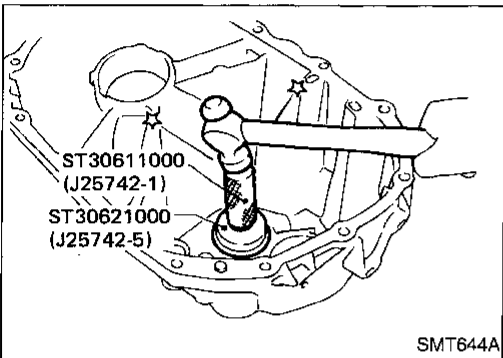

2. Reinstall mainshaft rear bearing outer race without shims.
3. Clean mating surfaces of clutch housing and transmission case with solvent.
4. Install mainshaft and mainshaft front bearing outer race into transmission case. Turn mainshaft while holding bearing outer race so that bearings are properly seated.

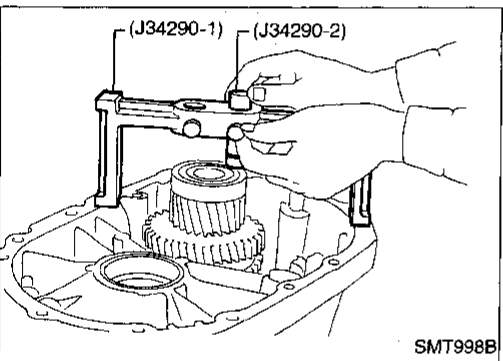

5. Place Tools (bridge and gauging cylinder) onto machined surface of transmission case. Allow gauging cylinder to rest on surface of mainshaft front bearing outer race. Use proper screw in bridge to lock gauging cylinder in place.

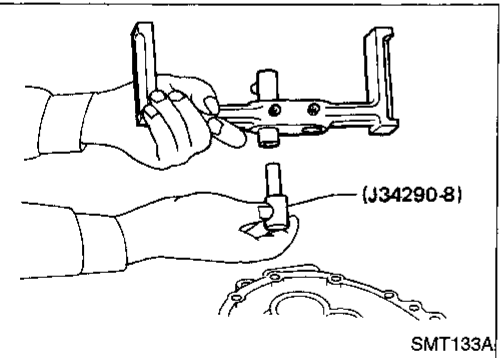

6. Turn bridge over and place Tool (gauging plunger) into gauging cylinder.

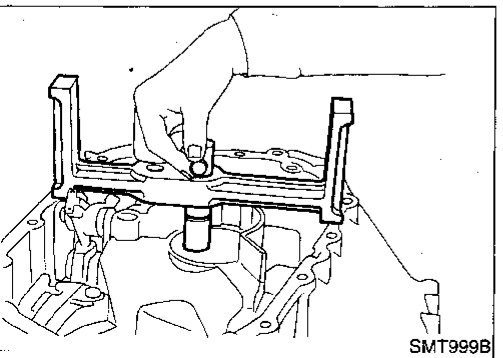

7. Place bridge, legs up, onto machined surface of clutch housing. Allow gauging plunger to rest upon mating surface where mainshaft front bearing outer race fits.

GI

MA

EM

LC

EC

FE

CL

MT

AT

FA

RA

BR

ST

RS

BT

HA

EL

IDX

ADJUSTMENT

Mainshaft Bearing Preload (Cont'd)

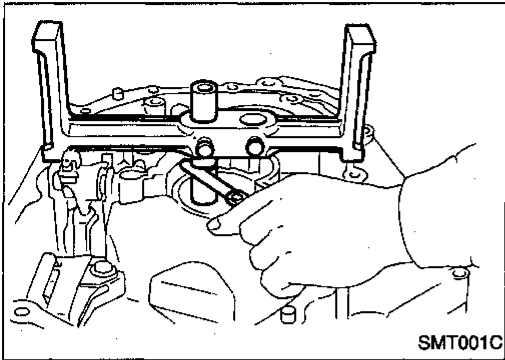

8. Use feeler gauge to measure the distance between gauging cylinder and shoulder of gauging plunger.
9. Use feeler gauge reading to select correct mainshaft preload shim(s).

Mainshaft bearing adjusting shim:

Refer to SDS, MT-43.

10. Install selected mainshaft bearing adjusting shim and mainshaft bearing outer race.
11. Check total turning torque after assembly. Refer to "ASSEMBLY" MT-37.

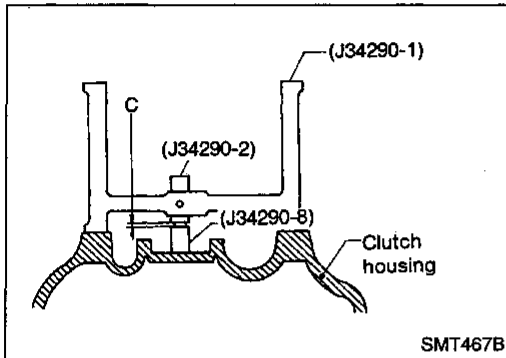

ASSEMBLY

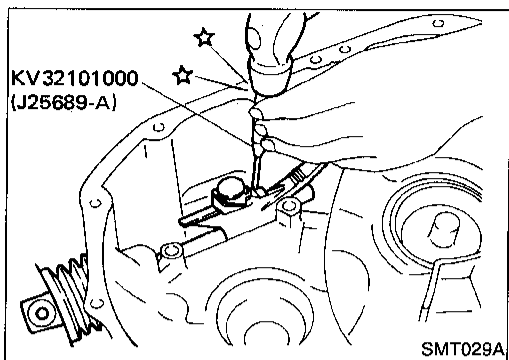

1. Install striking lever and striking rod with Tool.

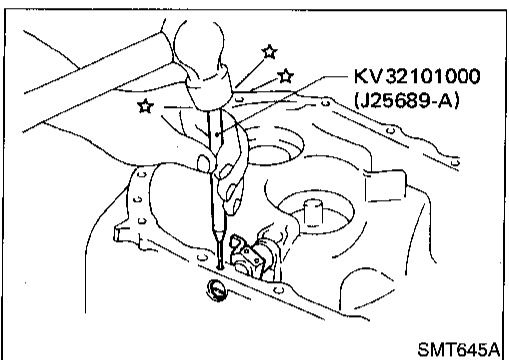

2. Install selector and retaining pin with Tool.

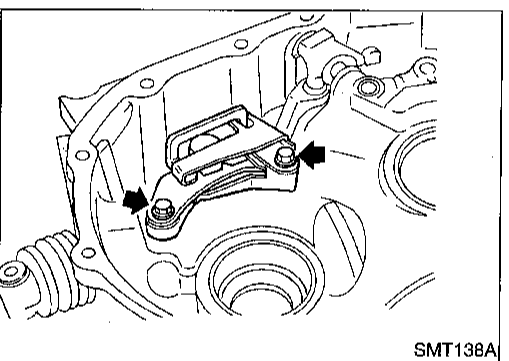

3. Install check ball and reverse check assembly.
 • **Before installation, rotate striking rod as shown in the figure to avoid interference.**

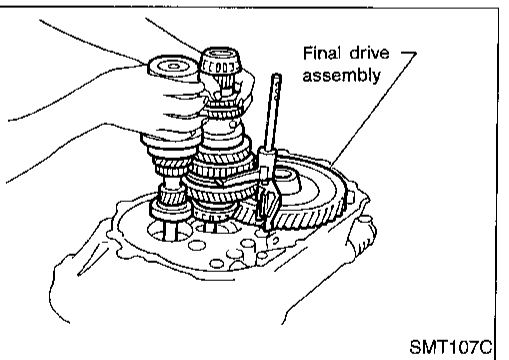

4. Install final drive assembly.
 5. Install input shaft and mainshaft with 1st & 2nd shift fork assembly.
 • **Be careful not to damage input shaft oil seal.**

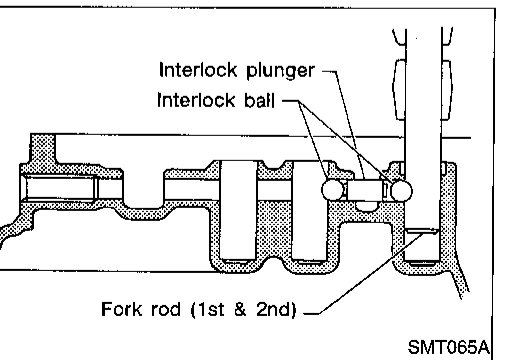

6. Install interlock balls and plunger.

GI

MA

EM

LC

EC

FE

CL

MT

AT

FA

RA

BR

ST

RS

BT

HA

EL

IDX

ASSEMBLY

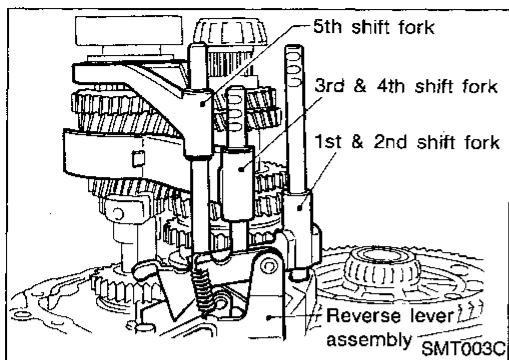

7. Install 3rd & 4th shift fork and bracket, then install 3rd & 4th fork rod, stopper ring and retaining pin.

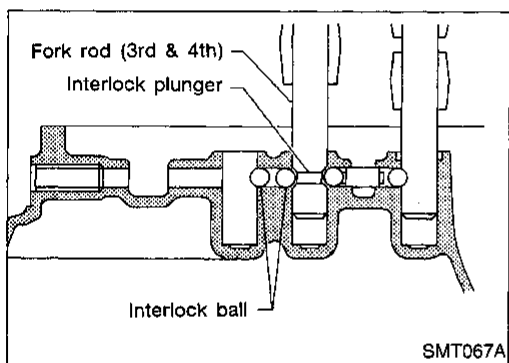
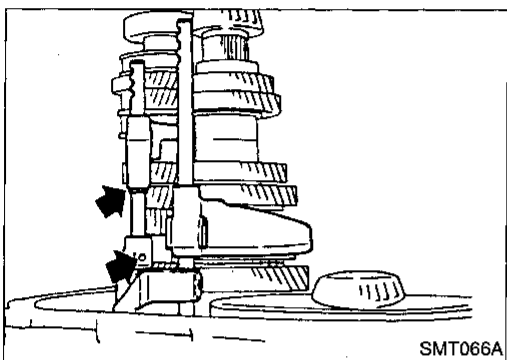

8. Install interlock balls.

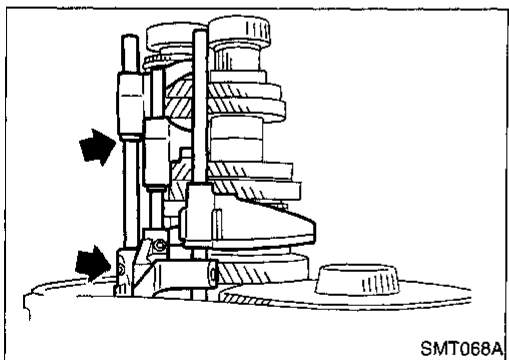

9. Install 5th shift fork and bracket, then install fork rod, stopper ring and retaining pin.

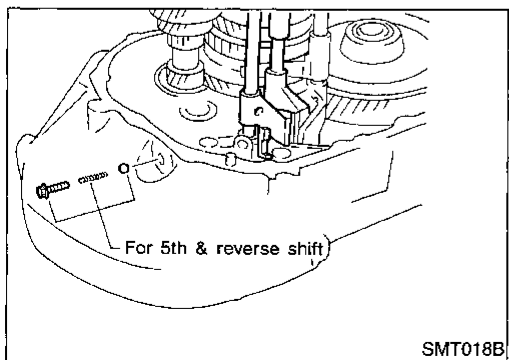

10. Install 5th & reverse check plug, spring and ball.

ASSEMBLY

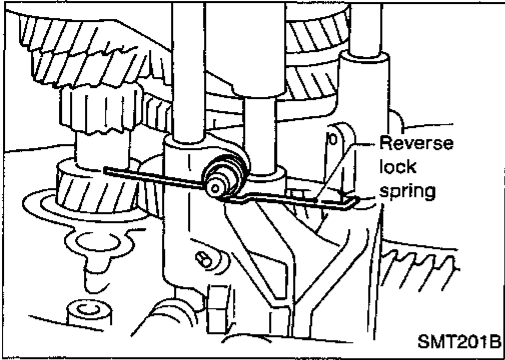

11. Install reverse lock spring on 5th & reverse bracket.
 - Pay attention to its direction.

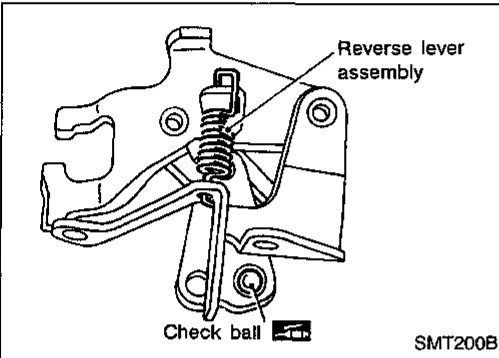

12. Install check ball and reverse lever spring on reverse lever assembly.
 - Apply multi-purpose grease to check ball.
 - Pay attention to direction of reverse lever spring.

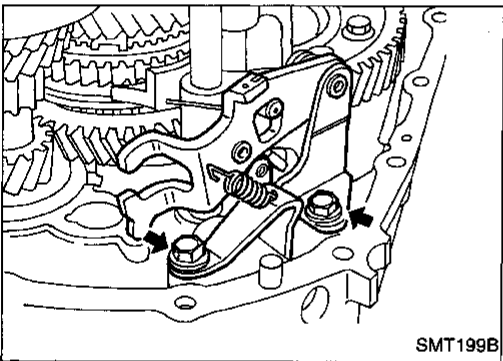

13. Install reverse lever assembly on clutch housing.

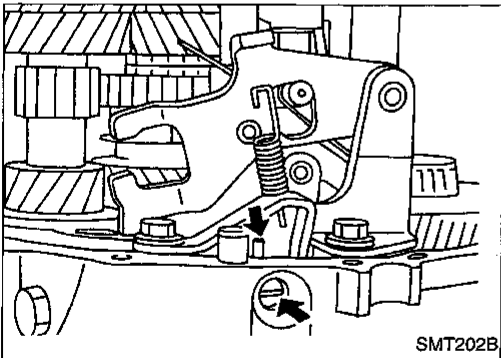

14. Install reverse arm shaft and retaining pin.

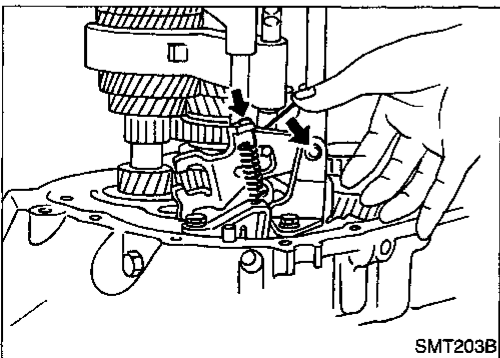

15. Hook reverse lock spring and reverse lever spring on reverse lever assembly.

GI

MA

EM

LC

EC

FE

CL

MT

AT

FA

RA

BR

ST

RS

BT

HA

EL

IDX

ASSEMBLY

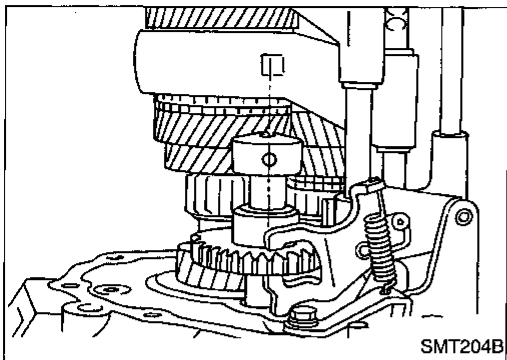

16. Mesh 4th gear, then install reverse idler gear and shaft.

- Pay attention to direction of tapped hole.

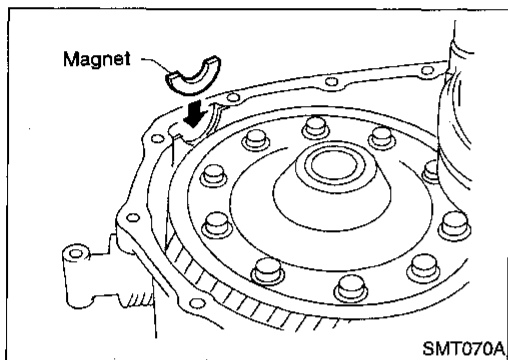

17. Place magnet on clutch housing.

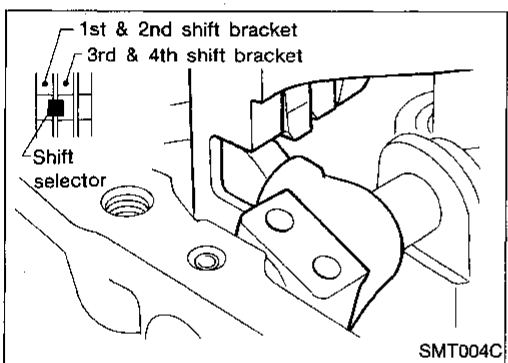

18. If bearing preload was adjusted, install selected shim(s) into transmission case.

- To aid in installation of transmission case, place shift selector in the 1st & 2nd shift bracket or between 1st & 2nd bracket and 3rd & 4th bracket.

19. Apply genuine anaerobic liquid gasket, Three Bond TB1215, Loctite 51813 or equivalent to mating surface of transmission case and install it.

20. Install park/neutral position (PNP) switch.

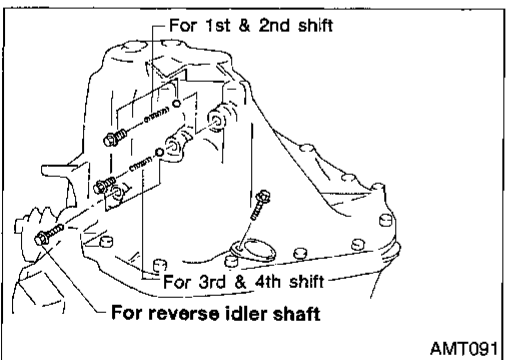

21. Apply genuine anaerobic liquid gasket, Three Bond TB1215, Loctite 51813 or equivalent to threads of check plugs. Install balls, springs and plugs.

22. After assembly, check that you can shift into each gear smoothly.

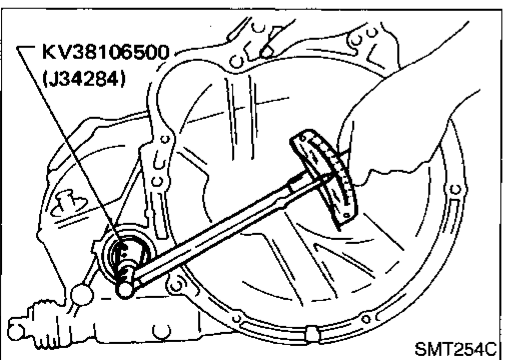

23. Measure total turning torque.

Total turning torque (New bearing):

8.8 - 21.6 N·m (90 - 220 kg·cm, 78 - 191 in·lb)

- When old bearing is used again, preload will be slightly less than the above. Make sure torque is close to the specified range.

SERVICE DATA AND SPECIFICATIONS (SDS)

General Specifications

TRANSAXLE

Engine		KA24DE	
Transaxle model		RS5F50A	
Number of speeds		5	
Synchronesh type		Warner	
Shift pattern			
Gear ratio	1st	3.285	
	2nd	1.850	
	3rd	1.206	
	4th	0.954	
	5th	0.740	
	Rev.	3.428	
Number of teeth	Input gear	1st	14
		2nd	20
		3rd	29
		4th	44
		5th	50
		Rev.	14
	Main gear	1st	46
		2nd	37
		3rd	35
		4th	42
		5th	37
		Rev.	48
Reverse idler gear		29	
Oil capacity ℓ (US pt, Imp pt)		4.5 - 4.8 (9-1/2 - 10-1/8, 7-7/8 - 8-1/2)	
Double baulk ring type synchronizer		2nd synchronizer	

FINAL GEAR

Transaxle model		RS5F50A	
Final gear ratio		3.650	
Number of teeth			
Final gear/Pinion		73/20	
Side gear/Pinion		16/10	

GI

MA

EM

LC

EC

FE

CL

MT

AT

FA

RA

BR

ST

RS

BT

HA

EL

IDX

SERVICE DATA AND SPECIFICATIONS (SDS)

Inspection and Adjustment

GEAR END PLAY

Gear	End play mm (in)
1st main gear	0.23 - 0.43 (0.0091 - 0.0169)
2nd main gear	0.23 - 0.58 (0.0091 - 0.0228)
3rd input gear	0.23 - 0.43 (0.0091 - 0.0169)
4th input gear	0.25 - 0.55 (0.0098 - 0.0217)
5th input gear	0.23 - 0.48 (0.0091 - 0.0189)

CLEARANCE BETWEEN BAULK RING AND GEAR

1st, 3rd, 4th & 5th

Unit: mm (in)

	Standard	Wear limit
1st	1.0 - 1.35 (0.0394 - 0.0531)	0.7 (0.028)
3rd & 4th	1.0 - 1.35 (0.0394 - 0.0531)	0.7 (0.028)
5th	1.0 - 1.35 (0.0394 - 0.0531)	0.7 (0.028)

Reverse baulk ring

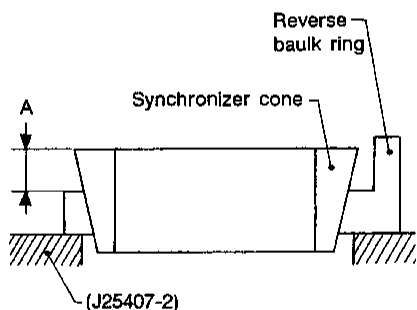

SMT581B

Dimension	Wear limit
A	1.2 mm (0.047 in)

2nd double baulk ring

Unit: mm (in)

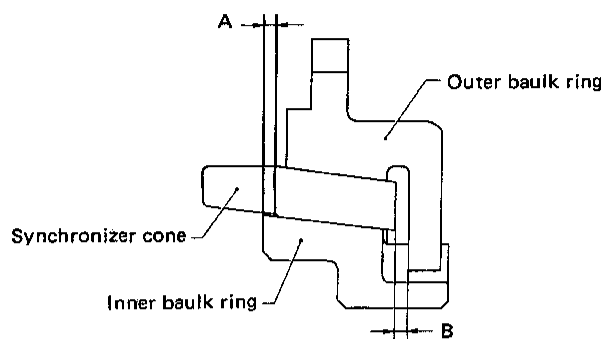

SMT806B

Dimension	Standard	Wear limit
A	0.6 - 0.8 (0.024 - 0.031)	0.2 (0.008)
B	0.6 - 1.1 (0.024 - 0.043)	

AVAILABLE SNAP RING

3rd & 4th synchronizer hub (At input shaft)

Allowable clearance		0 - 0.1 mm (0 - 0.004 in)
Thickness mm (in)	Part number	
1.95 (0.0768)	32269-03E03	
2.00 (0.0787)	32269-03E00	
2.05 (0.0807)	32269-03E01	
2.10 (0.0827)	32269-03E02	

1st & 2nd synchronizer hub (At mainshaft)

Allowable clearance		0 - 0.1 mm (0 - 0.004 in)
Thickness mm (in)	Part number	
1.95 (0.0768)	32269-03E03	
2.00 (0.0787)	32269-03E00	
2.05 (0.0807)	32269-03E01	
2.10 (0.0827)	32269-03E02	

5th main gear (At mainshaft)

Allowable clearance		0 - 0.15 mm (0 - 0.0059 in)
Thickness mm (in)	Part number	
1.95 (0.0768)	32348-05E00	
2.05 (0.0807)	32348-05E01	
2.15 (0.0846)	32348-05E02	
2.25 (0.0886)	32348-05E03	

SERVICE DATA AND SPECIFICATIONS (SDS)

Inspection and Adjustment (Cont'd)

AVAILABLE THRUST WASHER

4th input gear (At input shaft)

Allowable clearance		0 - 0.06 mm (0 - 0.0024 in)	
Thickness mm (in)	Part number		
4.500 (0.1772)	32278-03E01		
4.525 (0.1781)	32278-03E02		
4.550 (0.1791)	32278-03E03		
4.575 (0.1801)	32278-03E04		

Differential side gear thrust washer

Allowable clearance between side gear and differential case with washer		0.1 - 0.2 mm (0.004 - 0.008 in)	
Thickness mm (in)	Part number		
0.75 (0.0295)	38424-E3020		
0.80 (0.0315)	38424-E3021		
0.85 (0.0335)	38424-E3022		
0.90 (0.0354)	38424-E3023		

AVAILABLE SHIM

— INPUT SHAFT END PLAY AND MAINSHAFT AND DIFFERENTIAL SIDE BEARING PRELOAD AND ADJUSTING SHIM

Bearing preload and end play Unit: mm (in)

Mainshaft bearing preload	0.06 - 0.11 (0.0024 - 0.0043)
Input shaft end play	0 - 0.05 (0 - 0.0020)
Differential side bearing preload	0.40 - 0.45 (0.0157 - 0.0177)

Turning torque (New bearing)

Unit: N·m (kg·cm, in·lb)

Final drive only	4.9 - 7.8 (50 - 80, 43 - 69)
Total	8.8 - 21.6 (90 - 220, 78 - 191)

Mainshaft bearing adjusting shim

Thickness mm (in)	Part number
0.40 (0.0157)	32139-03E11
0.44 (0.0173)	32139-03E00
0.48 (0.0189)	32139-03E01
0.52 (0.0205)	32139-03E12
0.56 (0.0220)	32139-03E02
0.60 (0.0236)	32139-03E03
0.64 (0.0252)	32139-03E04
0.68 (0.0268)	32139-03E05
0.72 (0.0283)	32139-03E06
0.76 (0.0299)	32139-03E07
0.80 (0.0315)	32139-03E08
1.20 (0.0472)	32139-03E13

GI

MA

EM

LC

EC

FE

CL

MT

AT

FA

RA

BR

ST

RS

BT

HA

EL

IDX

SERVICE DATA AND SPECIFICATIONS (SDS)

Inspection and Adjustment (Cont'd)

Table for selecting mainshaft adjusting shim(s)

Unit: mm (in)

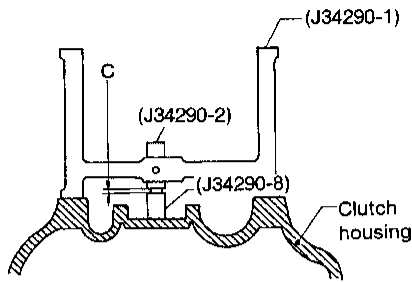

SMT467B

Dimension "C"	Suitable shim(s)
0.30 - 0.34 (0.0118 - 0.0134)	0.40 (0.0157)
0.34 - 0.38 (0.0134 - 0.0150)	0.44 (0.0173)
0.38 - 0.42 (0.0150 - 0.0165)	0.48 (0.0189)
0.42 - 0.46 (0.0165 - 0.0181)	0.52 (0.0205)
0.46 - 0.50 (0.0181 - 0.0197)	0.56 (0.0220)
0.50 - 0.54 (0.0197 - 0.0213)	0.60 (0.0236)
0.54 - 0.58 (0.0213 - 0.0228)	0.64 (0.0252)
0.58 - 0.62 (0.0228 - 0.0244)	0.68 (0.0268)
0.62 - 0.66 (0.0244 - 0.0260)	0.72 (0.0283)
0.66 - 0.70 (0.0260 - 0.0276)	0.76 (0.0299)
0.70 - 0.74 (0.0276 - 0.0291)	0.80 (0.0315)
0.74 - 0.78 (0.0291 - 0.0307)	0.40 + 0.44 (0.0157 + 0.0173)
0.78 - 0.82 (0.0307 - 0.0323)	0.44 + 0.44 (0.0173 + 0.0173)
0.82 - 0.86 (0.0323 - 0.0339)	0.44 + 0.48 (0.0173 + 0.0189)
0.86 - 0.90 (0.0339 - 0.0354)	0.48 + 0.48 (0.0189 + 0.0189)
0.90 - 0.94 (0.0354 - 0.0370)	0.48 + 0.52 (0.0189 + 0.0205)
0.94 - 0.98 (0.0370 - 0.0386)	0.52 + 0.52 (0.0205 + 0.0205)
0.98 - 1.02 (0.0386 - 0.0402)	0.52 + 0.56 (0.0205 + 0.0220)
1.02 - 1.06 (0.0402 - 0.0417)	0.56 + 0.56 (0.0220 + 0.0220)
1.06 - 1.10 (0.0417 - 0.0433)	0.56 + 0.60 (0.0220 + 0.0236)
1.10 - 1.14 (0.0433 - 0.0449)	0.60 + 0.60 (0.0236 + 0.0236)
1.14 - 1.18 (0.0449 - 0.0465)	0.60 + 0.64 (0.0236 + 0.0252)
1.18 - 1.22 (0.0465 - 0.0480)	0.64 + 0.64 (0.0252 + 0.0252)
1.22 - 1.26 (0.0480 - 0.0496)	0.64 + 0.68 (0.0252 + 0.0268)
1.26 - 1.30 (0.0496 - 0.0512)	0.68 + 0.68 (0.0268 + 0.0268)
1.30 - 1.34 (0.0512 - 0.0528)	0.68 + 0.72 (0.0268 + 0.0283)
1.34 - 1.38 (0.0528 - 0.0543)	0.72 + 0.72 (0.0283 + 0.0283)
1.38 - 1.42 (0.0543 - 0.0559)	0.72 + 0.76 (0.0283 + 0.0299)
1.42 - 1.46 (0.0559 - 0.0575)	0.76 + 0.76 (0.0299 + 0.0299)
1.46 - 1.50 (0.0575 - 0.0591)	0.76 + 0.80 (0.0299 + 0.0315)

Input shaft bearing adjusting shim

Thickness mm (in)	Part number
0.40 (0.0157)	32225-08E00
0.44 (0.0173)	32225-08E01
0.48 (0.0189)	32225-08E02
0.52 (0.0205)	32225-08E03
0.56 (0.0220)	32225-08E04
0.60 (0.0236)	32225-08E05
0.64 (0.0252)	32225-08E06
0.68 (0.0268)	32225-08E07
0.72 (0.0283)	32225-08E08
0.76 (0.0299)	32225-08E09
0.80 (0.0315)	32225-08E10
1.20 (0.0472)	32225-08E11

Table for selecting input shaft bearing adjusting shim(s)

Unit: mm (in)

Dial indicator deflection	Suitable shim(s)
0.65 - 0.69 (0.0256 - 0.0272)	0.64 (0.0252)
0.69 - 0.73 (0.0272 - 0.0287)	0.68 (0.0268)
0.73 - 0.77 (0.0287 - 0.0303)	0.72 (0.0283)
0.77 - 0.81 (0.0303 - 0.0319)	0.76 (0.0299)
0.81 - 0.85 (0.0319 - 0.0335)	0.80 (0.0315)
0.85 - 0.89 (0.0335 - 0.0350)	0.40 + 0.44 (0.0157 + 0.0173)
0.89 - 0.93 (0.0350 - 0.0366)	0.44 + 0.44 (0.0173 + 0.0173)
0.93 - 0.97 (0.0366 - 0.0382)	0.44 + 0.48 (0.0173 + 0.0189)
0.97 - 1.01 (0.0382 - 0.0398)	0.48 + 0.48 (0.0189 + 0.0189)
1.01 - 1.05 (0.0398 - 0.0413)	0.48 + 0.52 (0.0189 + 0.0205)
1.05 - 1.09 (0.0413 - 0.0429)	0.52 + 0.52 (0.0205 + 0.0205)
1.09 - 1.13 (0.0429 - 0.0445)	0.52 + 0.56 (0.0205 + 0.0220)
1.13 - 1.17 (0.0445 - 0.0461)	0.56 + 0.56 (0.0220 + 0.0220)
1.17 - 1.21 (0.0461 - 0.0476)	0.56 + 0.60 (0.0220 + 0.0236)
1.21 - 1.25 (0.0476 - 0.0492)	0.60 + 0.60 (0.0236 + 0.0236)
1.25 - 1.29 (0.0492 - 0.0508)	0.60 + 0.64 (0.0236 + 0.0252)
1.29 - 1.33 (0.0508 - 0.0524)	0.64 + 0.64 (0.0252 + 0.0252)
1.33 - 1.37 (0.0524 - 0.0539)	0.64 + 0.68 (0.0252 + 0.0268)
1.37 - 1.41 (0.0539 - 0.0555)	0.68 + 0.68 (0.0268 + 0.0268)
1.41 - 1.45 (0.0555 - 0.0571)	0.68 + 0.72 (0.0268 + 0.0283)
1.45 - 1.49 (0.0571 - 0.0587)	0.72 + 0.72 (0.0283 + 0.0283)
1.49 - 1.53 (0.0587 - 0.0602)	0.72 + 0.76 (0.0283 + 0.0299)
1.53 - 1.57 (0.0602 - 0.0618)	0.76 + 0.76 (0.0299 + 0.0299)
1.57 - 1.61 (0.0618 - 0.0634)	0.76 + 0.80 (0.0299 + 0.0315)
1.61 - 1.65 (0.0634 - 0.0650)	0.80 + 0.80 (0.0315 + 0.0315)
1.65 - 1.69 (0.0650 - 0.0665)	0.44 + 1.20 (0.0173 + 0.0472)

SERVICE DATA AND SPECIFICATIONS (SDS)

Inspection and Adjustment (Cont'd)

Differential side bearing adjusting shim

Thickness mm (in)	Part number
0.40 (0.0157)	38453-96E00
0.44 (0.0173)	38453-96E01
0.48 (0.0189)	38453-96E02
0.52 (0.0205)	38453-96E03
0.56 (0.0220)	38453-96E04
0.60 (0.0236)	38453-96E05
0.64 (0.0252)	38453-96E06
0.68 (0.0268)	38453-96E07
0.72 (0.0283)	38453-96E08
0.76 (0.0299)	38453-96E09
0.80 (0.0315)	38453-96E10
0.84 (0.0331)	38453-96E11
0.88 (0.0346)	38453-96E12
1.20 (0.0472)	38453-96E13

Table for selecting differential side bearing adjusting shim(s)

Dial indicator deflection	Suitable shim(s)	Unit: mm (in)
0.47 - 0.51 (0.0185 - 0.0201)	0.44 + 0.48 (0.0173 + 0.0189)	GI
0.51 - 0.55 (0.0201 - 0.0217)	0.48 + 0.48 (0.0189 + 0.0189)	MA
0.55 - 0.59 (0.0217 - 0.0232)	0.48 + 0.52 (0.0189 + 0.0205)	EM
0.59 - 0.63 (0.0232 - 0.0248)	0.52 + 0.52 (0.0205 + 0.0205)	LC
0.63 - 0.67 (0.0248 - 0.0264)	0.52 + 0.56 (0.0205 + 0.0220)	EC
0.67 - 0.71 (0.0264 - 0.0280)	0.56 + 0.56 (0.0220 + 0.0220)	FE
0.71 - 0.75 (0.0280 - 0.0295)	0.56 + 0.60 (0.0220 + 0.0236)	CL
0.75 - 0.79 (0.0295 - 0.0311)	0.60 + 0.60 (0.0236 + 0.0236)	MT
0.79 - 0.83 (0.0311 - 0.0327)	0.60 + 0.64 (0.0236 + 0.0252)	AT
0.83 - 0.87 (0.0327 - 0.0343)	0.64 + 0.64 (0.0252 + 0.0252)	FA
0.87 - 0.91 (0.0343 - 0.0358)	0.64 + 0.68 (0.0252 + 0.0268)	RA
0.91 - 0.95 (0.0358 - 0.0374)	0.68 + 0.68 (0.0268 + 0.0268)	BR
0.95 - 0.99 (0.0374 - 0.0390)	0.68 + 0.72 (0.0268 + 0.0283)	ST
0.99 - 1.03 (0.0390 - 0.0406)	0.72 + 0.72 (0.0283 + 0.0283)	RS
1.03 - 1.07 (0.0406 - 0.0421)	0.72 + 0.76 (0.0283 + 0.0299)	BT
1.07 - 1.11 (0.0421 - 0.0437)	0.76 + 0.76 (0.0299 + 0.0299)	HA
1.11 - 1.15 (0.0437 - 0.0453)	0.76 + 0.80 (0.0299 + 0.0315)	EL
1.15 - 1.19 (0.0453 - 0.0469)	0.80 + 0.80 (0.0315 + 0.0315)	IDX
1.19 - 1.23 (0.0469 - 0.0484)	0.44 + 1.20 (0.0173 + 0.0472)	
1.23 - 1.27 (0.0484 - 0.0500)	0.48 + 1.20 (0.0189 + 0.0472)	
1.27 - 1.31 (0.0500 - 0.0516)	0.52 + 1.20 (0.0205 + 0.0472)	