

SECTION **EL**

When you read wiring diagrams:

- Read GI section, "HOW TO READ WIRING DIAGRAMS".

When you perform trouble diagnoses, read GI section, "HOW TO FOLLOW FLOW CHART IN TROUBLE DIAGNOSES" and "HOW TO PERFORM EFFICIENT DIAGNOSIS FOR AN ELECTRICAL INCIDENT".

- Check for any service bulletins before servicing the vehicle.

CONTENTS

PRECAUTIONS AND PREPARATION	2	Combination Switch/Check.....	34
Supplemental Restraint System (SRS) "AIR BAG"	2	Replacement.....	35
HARNESS CONNECTOR	3	Steering Switch/Check.....	36
Description	3	HEADLAMP	37
STANDARDIZED RELAY	4	System Description (For USA)	37
Description	4	Wiring Diagram (For USA) — H/LAMP —	38
POWER SUPPLY ROUTING	6	Trouble Diagnoses.....	39
Schematic	6	Bulb Replacement.....	40
Wiring Diagram — POWER —	8	Aiming Adjustment	40
Fuse	15	HEADLAMP — Daytime Light System —	42
Fusible Link.....	15	System Description (For Canada)	42
Circuit Breaker Inspection.....	15	Operation (For Canada).....	43
GROUND DISTRIBUTION	16	Schematic (For Canada).....	44
BATTERY	19	Wiring Diagram (For Canada) — DTRL —	45
How to Handle Battery.....	19	Trouble Diagnoses (For Canada)	48
Service Data and Specifications (SDS).....	22	Bulb Replacement.....	49
STARTING SYSTEM	23	Aiming Adjustment	49
System Description	23	PARKING, LICENSE AND TAIL LAMPS	50
Wiring Diagram — START —	25	Wiring Diagram — TAIL/L —	50
Construction.....	27	STOP LAMP	52
Removal and Installation	27	Wiring Diagram — STOP/L —	52
Pinion/Clutch Check.....	27	BACK-UP LAMP	53
Service Data and Specifications (SDS).....	28	Wiring Diagram — BACK/L —	53
CHARGING SYSTEM	29	FRONT FOG LAMP	54
System Description	29	System Description	54
Wiring Diagram — CHARGE —	30	Wiring Diagram — F/FOG —	55
Trouble Diagnoses.....	31	Aiming Adjustment	56
Construction.....	32	TURN SIGNAL AND HAZARD WARNING LAMPS	57
Removal and Installation	33	System Description	57
Service Data and Specifications (SDS).....	33	Wiring Diagram — TURN —	60
COMBINATION SWITCH	34	Trouble Diagnoses.....	62

CONTENTS (Cont'd.)

Electrical Components Inspection	62	Trouble Diagnoses (For models without power door locks)	120
ILLUMINATION	63	Electrical Components Inspection	121
System Description	63	Filament Check	121
Wiring Diagram — ILL —	64	Filament Repair	122
INTERIOR ROOM LAMP	66	AUDIO	124
Component Parts and Harness Connector		System Description	124
Location	66	Wiring Diagram — AUDIO —	126
System Description	67	Trouble Diagnoses	129
Wiring Diagram — ROOM/L —	70	Inspection	130
Trouble Diagnoses (For models with power door lock)	73	AUDIO ANTENNA	131
SPOT, TRUNK ROOM AND VANITY MIRROR LAMPS	74	System Description	131
Wiring Diagram — INT/L —	74	Wiring Diagram — P/ANT —	132
METER AND GAUGES	76	Trouble Diagnoses	133
Component Parts and Harness Connector		Location of Antenna	133
Location	76	Antenna Rod Replacement	133
System Description	77	Fixed Antenna Rod Replacement	135
Wiring Diagram — METER —	79	Removal	135
Trouble Diagnoses	80	Installation	135
WARNING LAMPS	84	Window Antenna Repair	136
System Description	84	ELECTRIC SUNROOF	137
Schematic	86	Wiring Diagram — SROOF —	137
Wiring Diagram — WARN —	87	POWER DOOR MIRROR	139
Electrical Components Inspection	90	Wiring Diagram — MIRROR —	139
WARNING CHIME	91	POWER SEAT	140
Component Parts and Harness Connector		Wiring Diagram — SEAT —	140
Location	91	AUTOMATIC SPEED CONTROL DEVICE (ASCD)	141
System Description	92	Component Parts and Harness Connector	
Wiring Diagram — CHIME —	94	Location	141
Trouble Diagnoses	96	System Description	142
Electrical Components Inspection	102	Schematic	144
FRONT WIPER AND WASHER	104	Wiring Diagram — ASCD —	145
System Description	104	Fail-safe System Description	149
Wiring Diagram — WIPER —	106	Fail-Safe System Check	150
Trouble Diagnoses	108	Trouble Diagnoses	151
Removal and Installation	110	ASCD Wire Adjustment	159
Washer Nozzle Adjustment	111	Electrical Components Inspection	160
Washer Tube Layout	111	POWER WINDOW	161
HORN	112	System Description	161
Wiring Diagram — HORN —	112	Wiring Diagram — WINDOW —	164
CIGARETTE LIGHTER	113	Trouble Diagnoses	166
Wiring Diagram — CIGAR —	113	POWER DOOR LOCK	167
REAR WINDOW DEFOGGER	114	Component Parts and Harness Connector	
Component Parts and Harness Connector		Location	167
Location	114	System Description	168
System Description	115	Schematic	170
Wiring Diagram — DEF —	117	Wiring Diagram — D/LOCK —	171
Trouble Diagnoses (For models with power door locks)	119	Trouble Diagnoses	174
		MULTI-REMOTE CONTROL SYSTEM	182

CONTENTS (Cont'd.)

Component Parts and Harness Connector		Passenger Compartment.....	228	
Location.....	182	HARNES LAYOUT	230	GI
System Description	183	Outline.....	230	
Schematic	185	How to Read Harness Layout	231	MA
Wiring Diagram — MULTI —.....	186	Main Harness.....	232	
Trouble Diagnoses.....	189	Engine Room Harness.....	234	
Electrical Components Inspection	195	Engine Control Harness.....	238	EM
ID Code Entry Procedure	196	Engine No. 2 Harness	240	
THEFT WARNING SYSTEM	197	Body Harness	242	
Component Parts and Harness Connector		Tail Harness	244	LC
Location.....	197	Room Lamp	245	
System Description	199	Door Harness (LH side).....	246	EC
Schematic	203	Door Harness (RH side)	247	
Wiring Diagram — THEFT —.....	204	Air Bag Harness.....	248	
Trouble Diagnoses.....	208	BULB SPECIFICATIONS	249	FE
SMART ENTRANCE CONTROL UNIT	221	Headlamp.....	249	
Description	221	Exterior Lamp.....	249	
Input/Output Operation Signal	222	Interior Lamp.....	249	CL
Schematic	224	WIRING DIAGRAM CODES (CELL CODES)	250	
LOCATION OF ELECTRICAL UNITS	226			MT
Engine Compartment.....	226			

WIRING DIAGRAM REFERENCE CHART

ECCS	EC SECTION
A/T CONTROL, SHIFT LOCK CONTROL	AT SECTION
ANTI-LOCK BRAKE SYSTEM	BR SECTION
SRS "AIR BAG"	RS SECTION
HEATER AND AIR CONDITIONER	HA SECTION

EL

IDX

Supplemental Restraint System (SRS) “AIR BAG”

The Supplemental Restraint System “Air Bag”, used along with a seat belt, helps to reduce the risk or severity of injury to the driver and front passenger in a frontal collision. The Supplemental Restraint System consists of air bag modules (located in the center of the steering wheel and on the instrument panel on the passenger side), a diagnosis sensor unit, warning lamp, wiring harness and spiral cable. Information necessary to service the system safely is included in the **RS section** of this Service Manual.

WARNING:

- **To avoid rendering the SRS inoperative, which could increase the risk of personal injury or death in the event of a collision which would result in air bag inflation, all maintenance must be performed by an authorized NISSAN dealer.**
- **Improper maintenance, including incorrect removal and installation of the SRS, can lead to personal injury caused by unintentional activation of the system.**
- **Do not use electrical test equipment on any circuit related to the SRS unless instructed to in this Service Manual. SRS wiring harnesses are covered with yellow insulation just before the harness connectors for easy identification.**

HARNESS CONNECTOR

Description

HARNESS CONNECTOR

- All harness connectors have been modified to prevent accidental looseness or disconnection.
- The connector can be disconnected by pushing or lifting the locking section.

CAUTION:

Do not pull the harness when disconnecting the connector.

[Example]

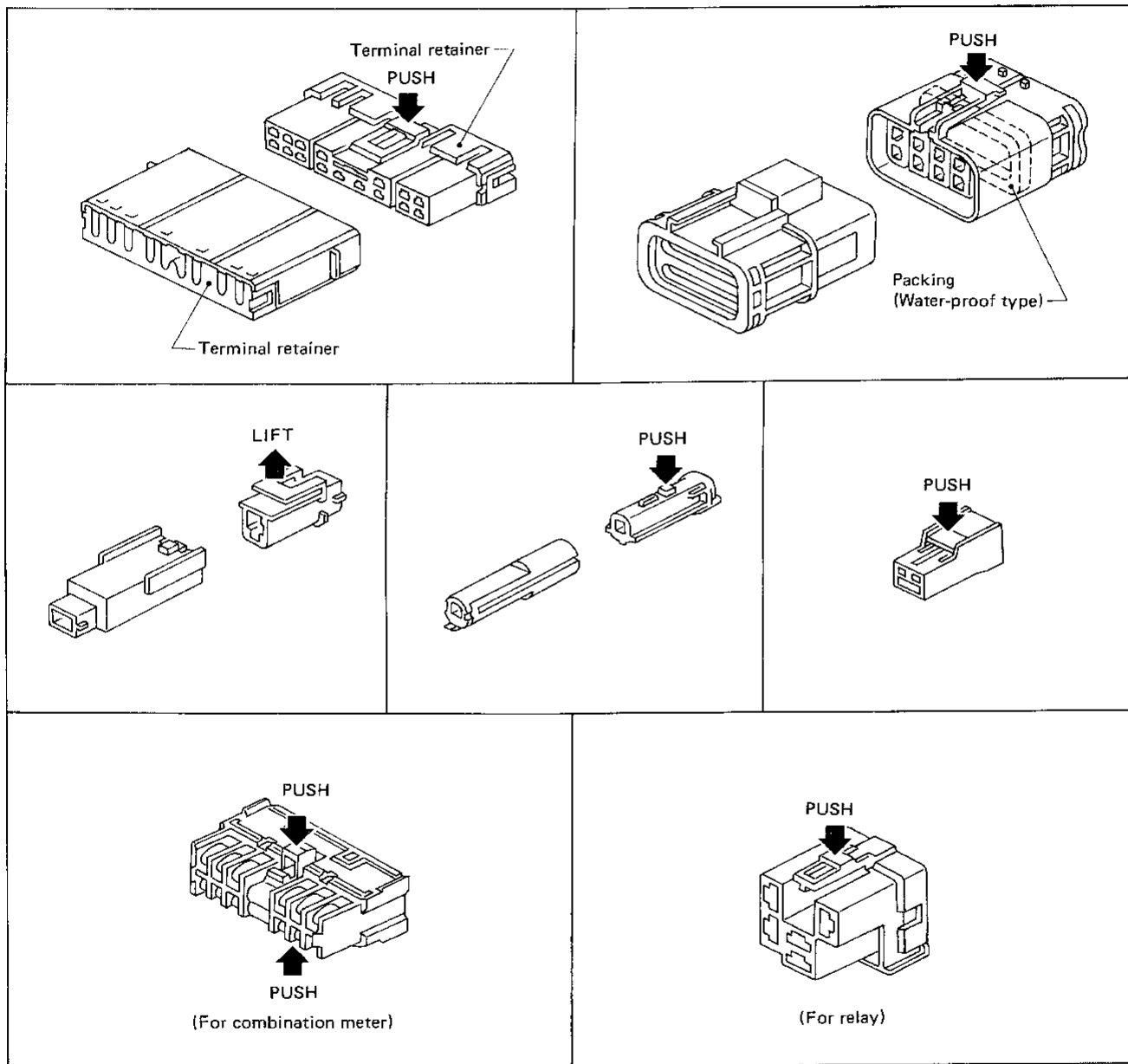

GI

MA

EM

LC

EC

FE

CL

MT

AT

FA

RA

BR

ST

RS

BT

HA

EL

IDX

SEL769D

STANDARDIZED RELAY

Description

NORMAL OPEN, NORMAL CLOSED AND MIXED TYPE RELAYS

Relays can be divided into three main types: normal open, normal closed and mixed type relays.

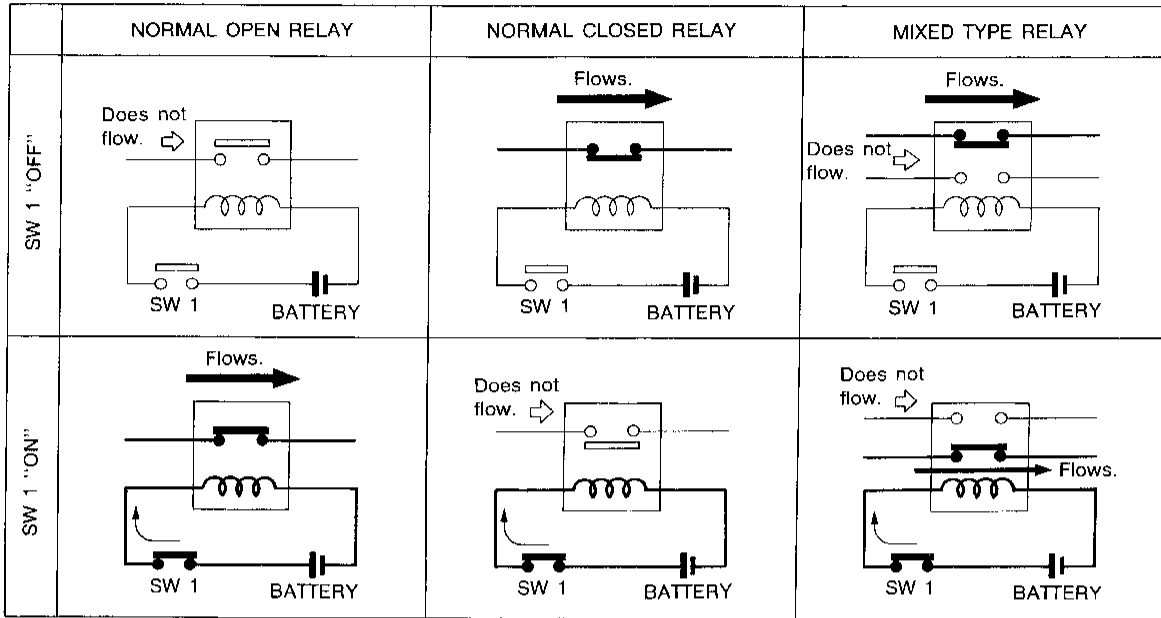

SEL881H

TYPES OF STANDARDIZED RELAYS

1M 1 Make 2M 2 Make
 1T 1 Transfer 1M-1B 1 Make 1 Break

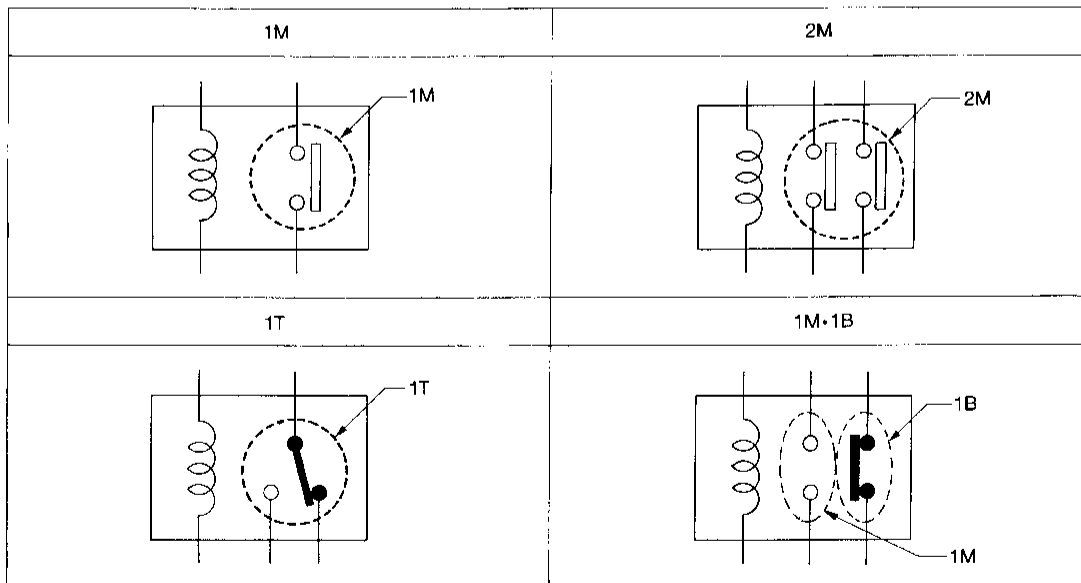

SEL882H

STANDARDIZED RELAY

Description (Cont'd)

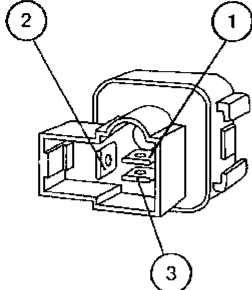
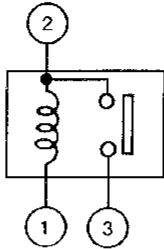
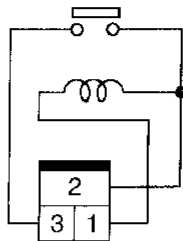
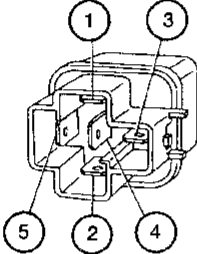
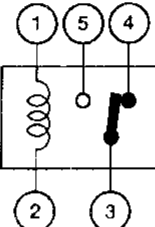
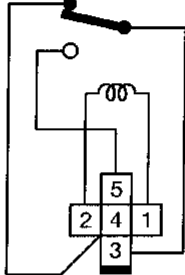
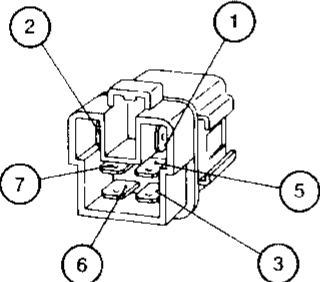
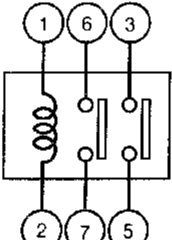
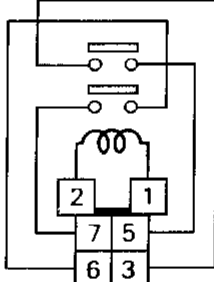
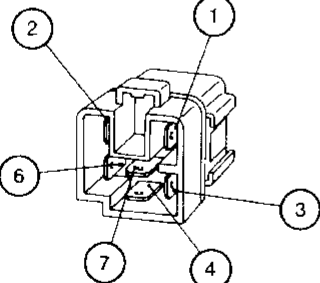
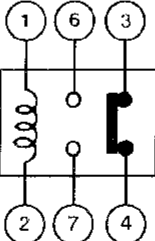
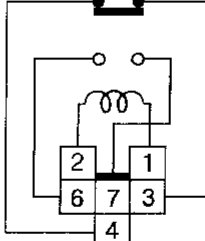
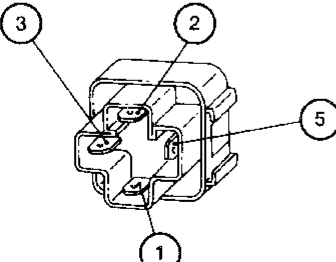
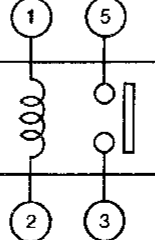
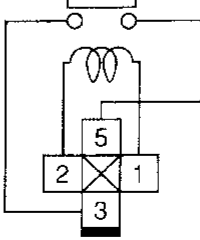
Type	Outer view	Circuit	Connector symbol and connection	Case color
1M				WHITE
1T				BLACK
2M				BROWN
1M-1B				GRAY
1M				BLUE

The arrangement of terminal numbers on the actual relays may differ from those shown above.

GI

MA

EM

LC

EC

FE

CL

MT

AT

FA

RA

BR

ST

RS

BT

HA

EL

IDX

POWER SUPPLY ROUTING

Schematic

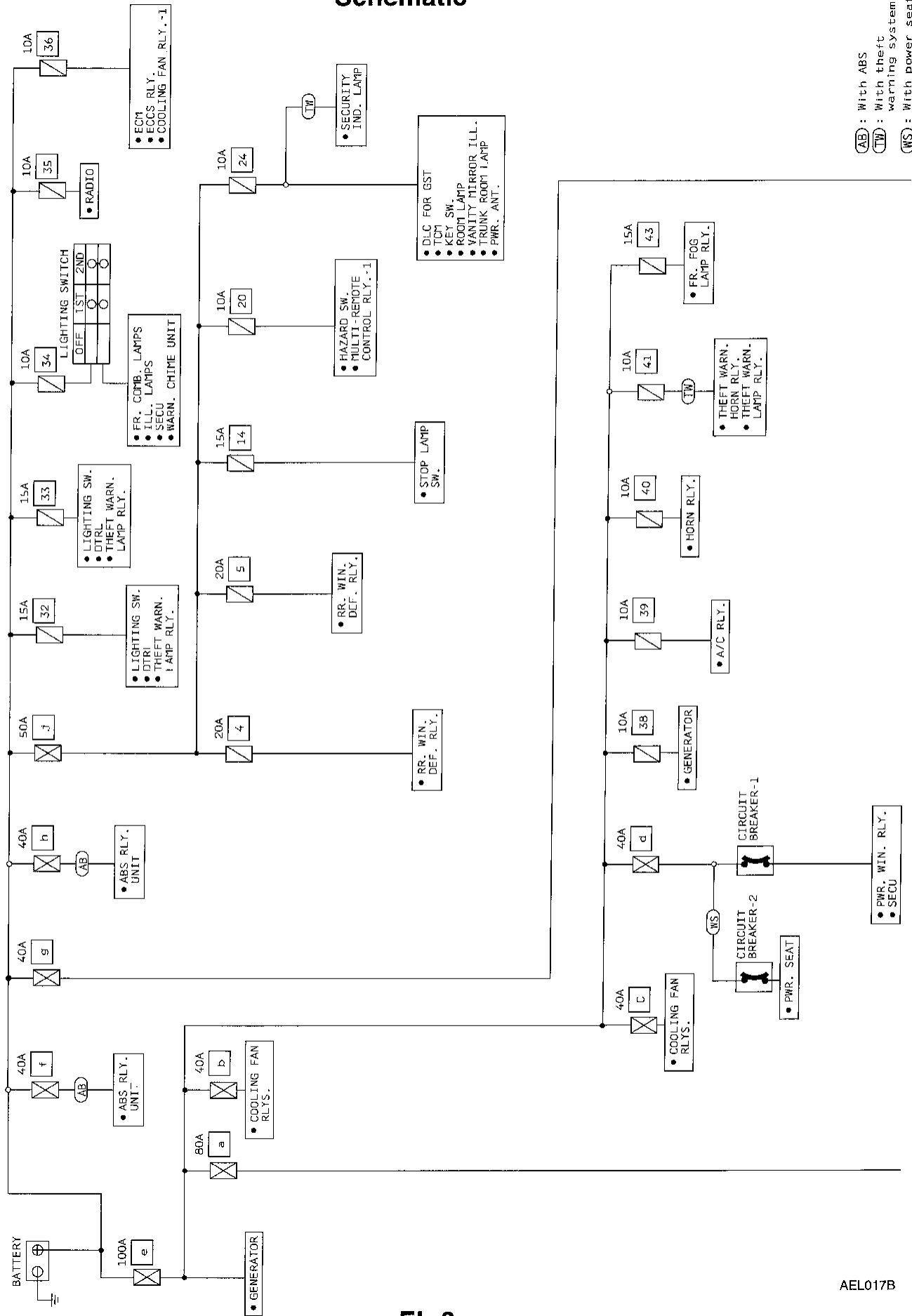

POWER SUPPLY ROUTING

Wiring Diagram — POWER —

BATTERY POWER SUPPLY – IGNITION SW. IN ANY POSITION

EL-POWER-01

: With theft warning system
 : With power seat

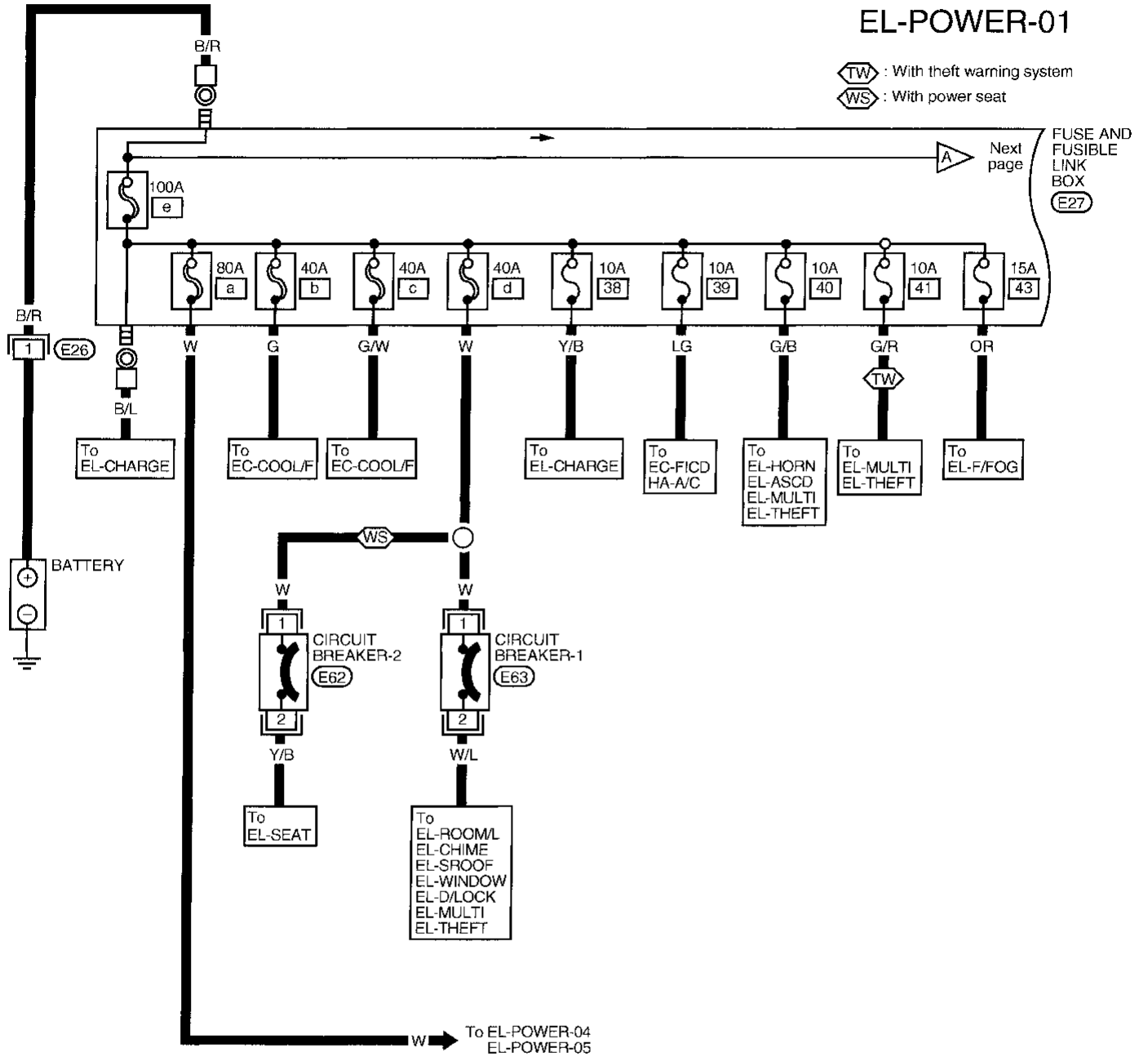

POWER SUPPLY ROUTING

Wiring Diagram — POWER — (Cont'd)

EL-POWER-02

: With ABS

: With theft warning system

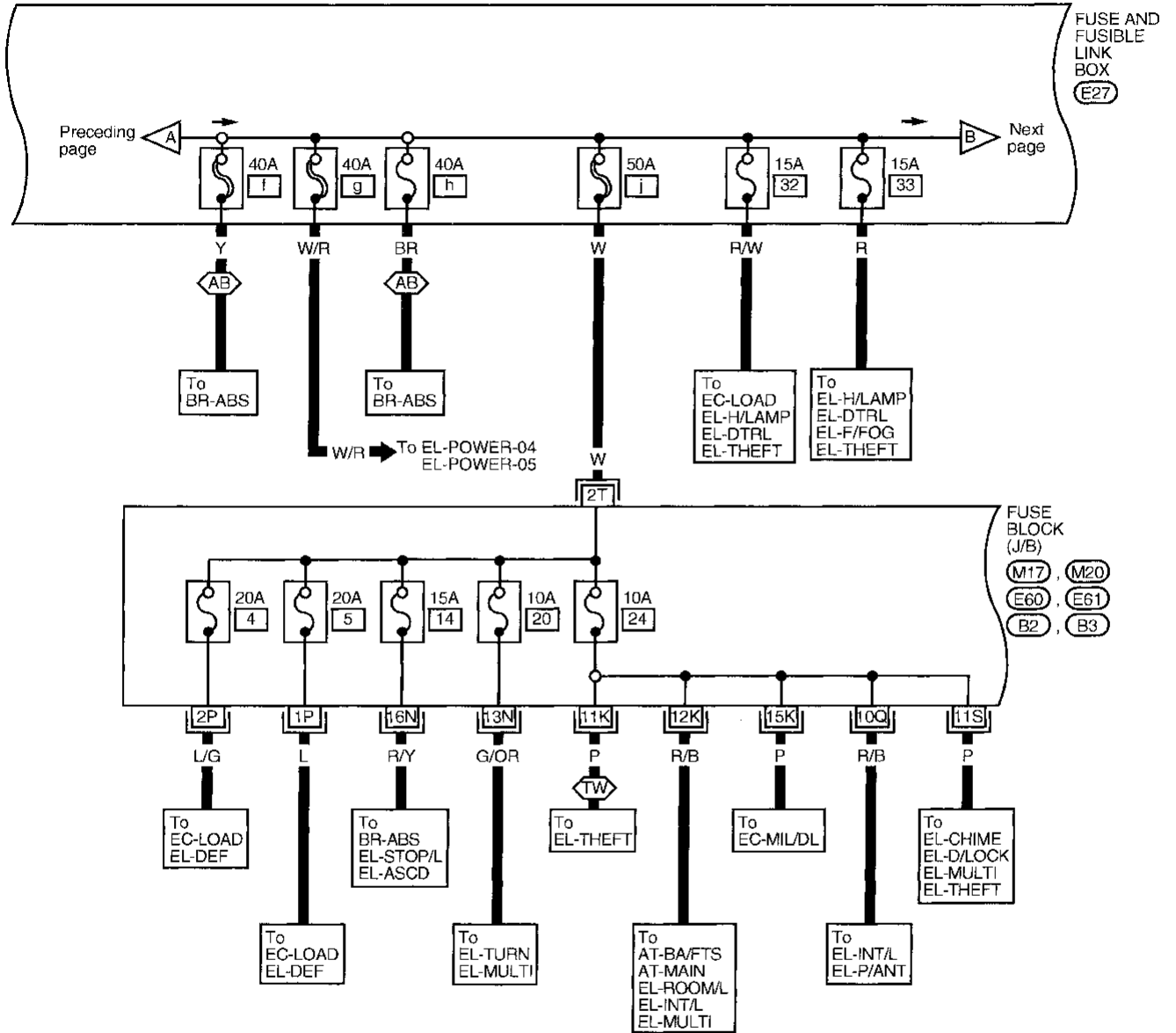

Refer to last page (Foldout page).

1	2	3	4	5
6	7	8	9	10
11	12	13	14	15
16	17	18	19	20
21	22	23		
24	25	26		
27	28	29		

AEL021B

POWER SUPPLY ROUTING

Wiring Diagram — POWER — (Cont'd)

EL-POWER-03

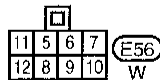
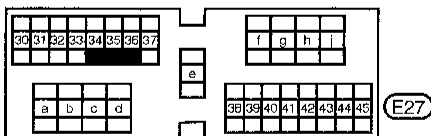
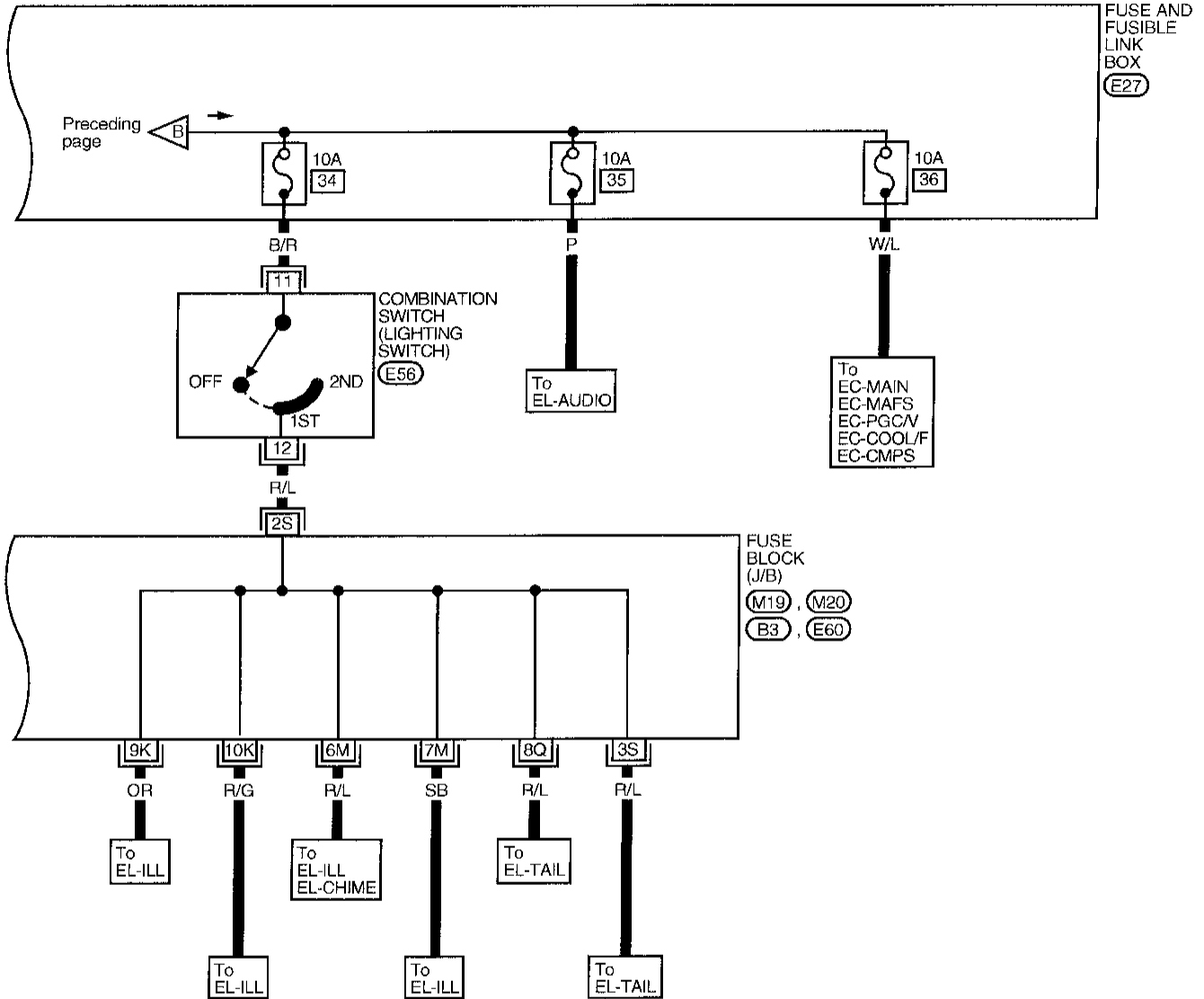

Refer to last page (Foldout page).

M19, M20, B3, E60

1	2	3	4	5
6	7	8	9	10
11	12	13	14	15
16	17	18	19	20
21	22	23		
24	25	26		
27	28	29		

POWER SUPPLY ROUTING

Wiring Diagram — POWER — (Cont'd)

ACCESSORY POWER SUPPLY – IGNITION SW. IN “ACC” OR “ON”

EL-POWER-04 GI

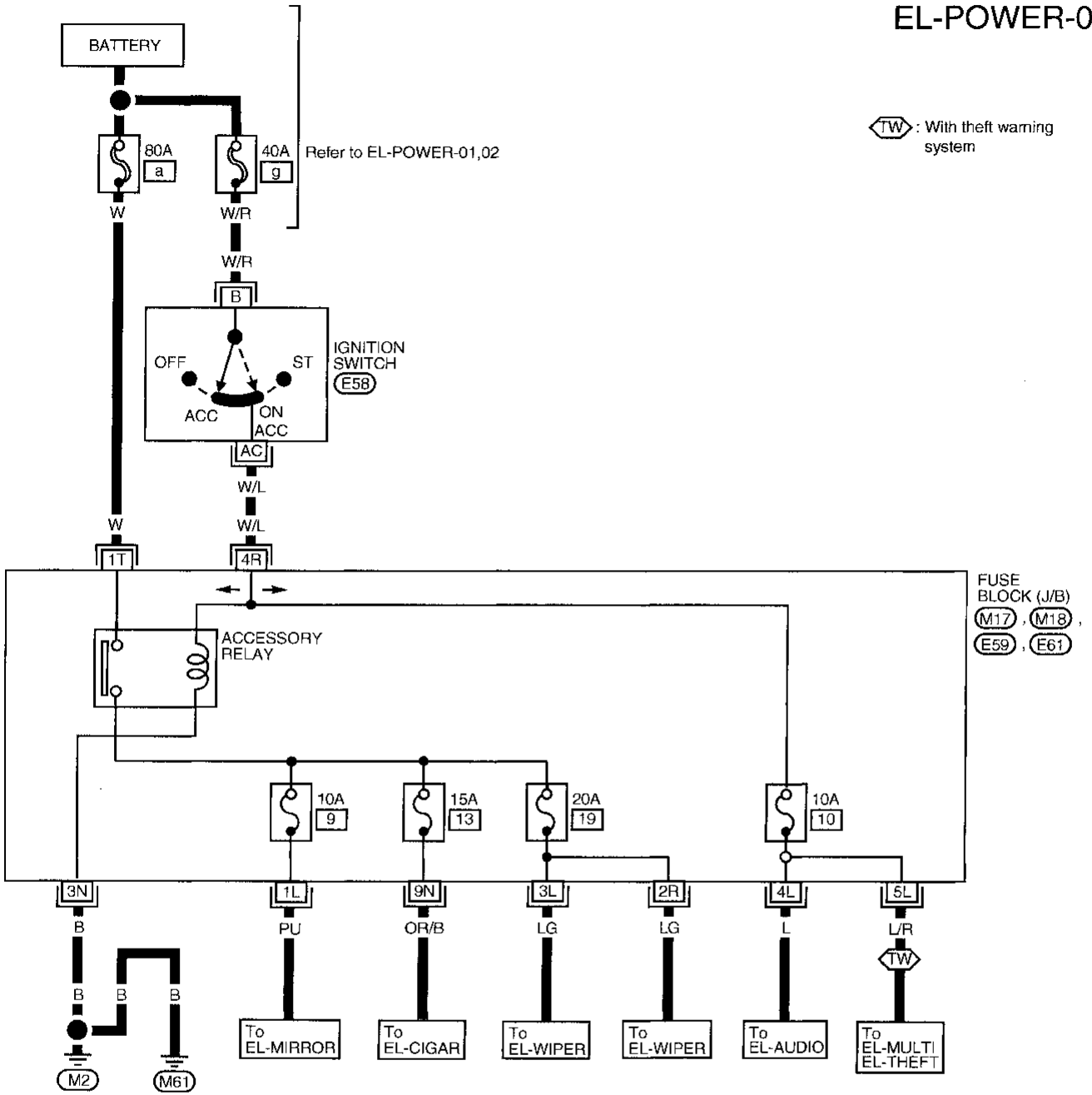

: With theft warning system

FUSE BLOCK (J/B)
 (M17), (M18),
 (E59), (E61)

B	11	ST	(E58)
R	AC	12	

W

Refer to last page (Foldout page).

(M17), (M18), (E59), (E61)				
1	2	3	4	5
6	7	8	9	10
11	12	13	14	15
16	17	18	19	20
21	22	23		
24	25	26		
27	28	29		

MA

EM

LC

EC

FE

CL

MT

AT

FA

RA

BR

ST

RS

BT

HA

EL

IDX

POWER SUPPLY ROUTING

Wiring Diagram — POWER — (Cont'd)

EL-POWER-06

AB : With ABS
N : For Canada

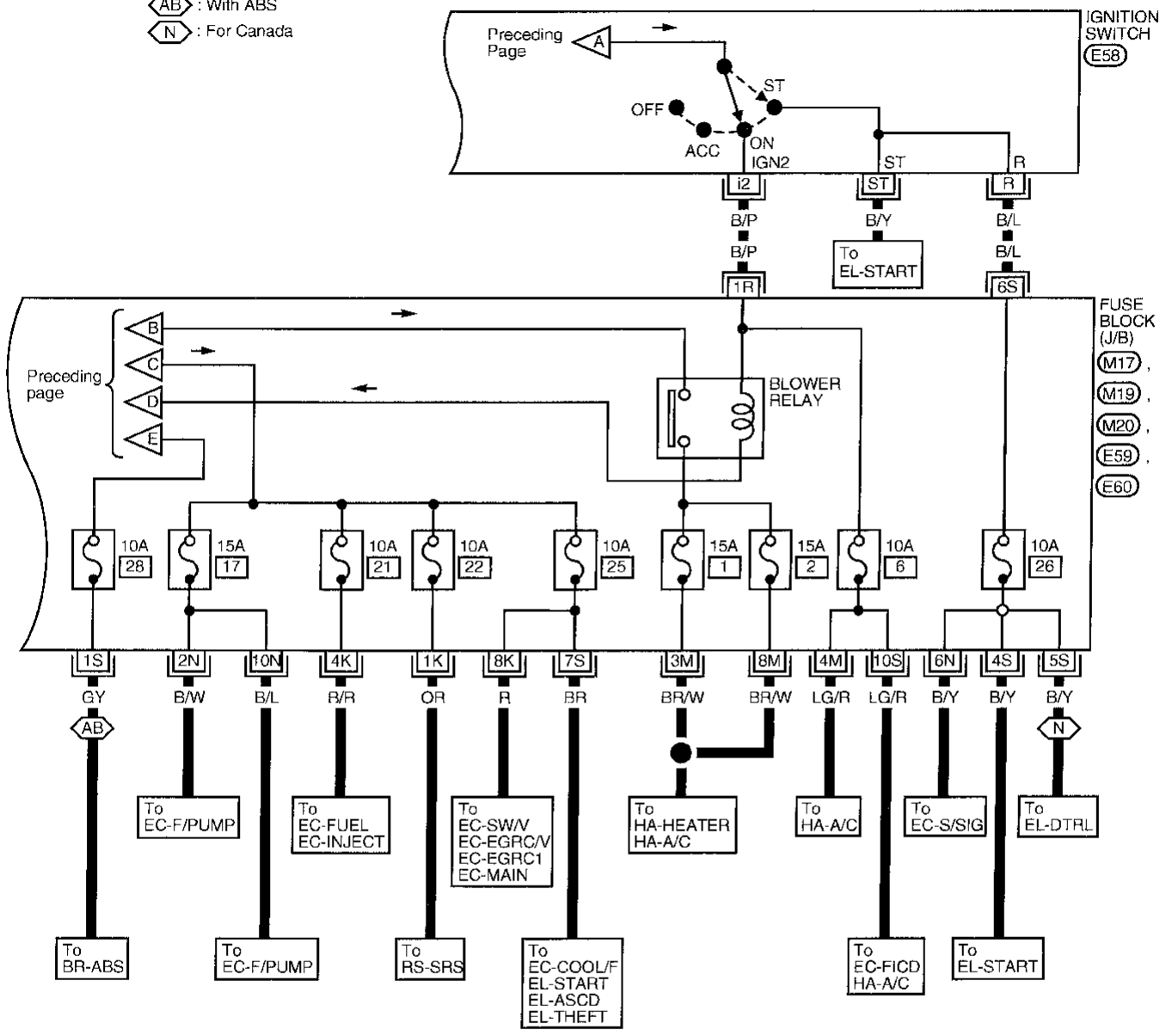

GI
MA
EM
LC
EC
FE
CL
MT
AT
FA
RA
BR
ST
RS
BT
HA
EL
IDX



Refer to last page (Foldout page).

(M17), (M19), (M20), (E59)
(E60)

1	2	3	4	5
6	7	8	9	10
11	12	13	14	15
16	17	18	19	20
21	22	23		
24	25	26		
27	28	29		

NOTES

POWER SUPPLY ROUTING

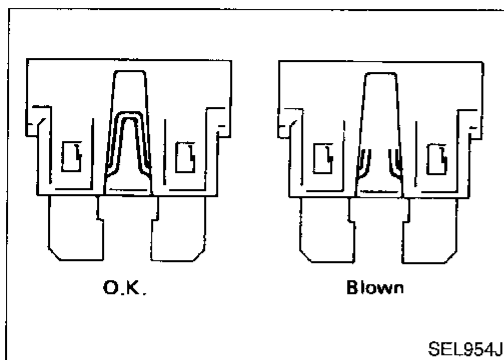

Fuse

- If fuse is blown, be sure to eliminate cause of problem before installing new fuse.
- Use fuse of specified rating. Never use fuse of more than specified rating.
- Do not partially install fuse; always insert it into fuse holder properly.
- Remove fuse for "ELECTRICAL PARTS (BAT)" if vehicle is not used for a long period of time.

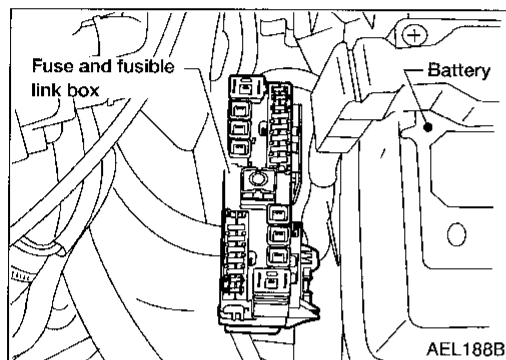

Fusible Link

A melted fusible link can be detected either by visual inspection or by feeling with finger tip. If its condition is questionable, use circuit tester or test lamp.

CAUTION:

- If fusible link should melt, it is possible that critical circuit (power supply or large current carrying circuit) is shorted. In such a case, carefully check and eliminate cause of problem.
- Never wrap outside of fusible link with vinyl tape. Important: Never let fusible link touch any other wiring harness, vinyl or rubber parts.

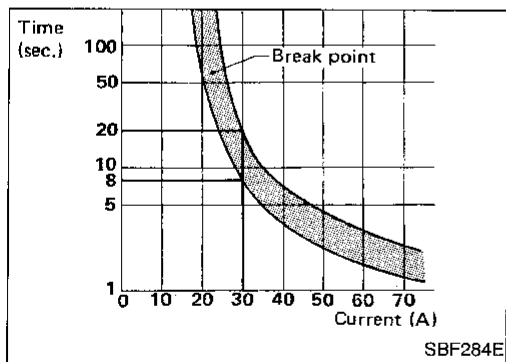

Circuit Breaker Inspection

For example, when current is 30A, the circuit is broken within 8 to 20 seconds.

Circuit breakers are used in the following systems.

- Power window & power door lock
- Power sunroof
- Power seat
- Multi-remote control system
- Theft warning system

CI

MA

EM

LC

EC

FE

CL

MT

AT

FA

RA

BR

ST

RS

BT

HA

EL

IDX

GROUND DISTRIBUTION

GROUND	CONNECT TO	CONN. NO.	CELL CODE
M2/M61	A/T DEVICE	M50	AT-SHIFT
	A/T DEVICE (OVERDRIVE CONTROL SWITCH)	M50	AT-NONDTC
	ASCD CONTROL UNIT	M30	EL-ASCD
	ASCD HOLD RELAY	M28: A/T M29: M/T	EL-ASCD
	ASCD MAIN SWITCH	M22	EL-ASCD
	CIGARETTE LIGHTER SOCKET	M58	EL-CIGAR
	CLUTCH INTERLOCK SWITCH	M27	EL-START
	COMBINATION FLASHER UNIT	M34	EL-TURN
	COMBINATION METER (AIR BAG WARNING LAMP)	M36	RS-SRS, EL-WARN
	COMBINATION METER (FUEL GAUGE)	M36	EL-METER
	COMBINATION METER (HIGH BEAM INDICATOR)	M14	EL-H/LAMP, EL-DTRL
	COMBINATION METER (SPEEDOMETER)	M36	EC-VSS, AT-VSSMTR, EL-ASCD, EL-METER
	COMBINATION METER (TACHOMETER)	M36	EL-METER
	COMBINATION METER (TURN SIGNAL INDICATOR)	M37	EL-TURN
	COMBINATION METER (WATER TEMPERATURE GAUGE)	M36	EL-METER
	DATA LINK CONNECTOR FOR CONSULT	M15	EC-MIL/DL, AT-NONDTC
	DATA LINK CONNECTOR FOR GST	M16	EL-MIL/DL
	DOOR MIRROR REMOTE CONTROL SWITCH	M23	EL-MIRROR
	FAN SWITCH	M46	EC-LOAD, HA-A/C, HA-HEATER
	FULL COOL SWITCH	M49	HA-A/C
	FUSE BLOCK (ACCESSORY RELAY)	M17	EL-POWER
	FUSE BLOCK (BLOWER RELAY)	M17	EL-POWER
	FUSE BLOCK (IGNITION RELAY)	M17	EL-POWER
	GLOVE BOX LAMP	M54	EL-ILL
	ILLUMINATION CONTROL SWITCH	M21	EL-ILL
	INTAKE DOOR MOTOR	M53	HA-A/C
	MODE DOOR MOTOR	M39	HA-A/C
	POWER WINDOW RELAY	M9	EL-SROOF, EL-WINDOW
	PUSH CONTROL UNIT	M48	HA-A/C
	REAR WINDOW DEFOGGER SWITCH	M35	EL-DEF
	REAR WINDOW DEFOGGER TIMER	M32	EL-DEF
	SMART ENTRANCE CONTROL UNIT	M33	EL-CHIME, EL-D/LOCK, EL-DEF, EL-ROOM/L, EL-MULTI, EL-THEFT
	WARNING CHIME UNIT	M31	EL-CHIME
	WIPER AMPLIFIER	M65	EL-WIPER
	WIPER MOTOR	M64	EL-WIPER
	VANITY MIRROR ILLUMINATION LH	R2	EL-INT/L
	VANITY MIRROR ILLUMINATION RH	R4	EL-INT/L
	FRONT DOOR KEY CYLINDER SWITCH LH	D9	EL-D/LOCK, EL-THEFT
	FRONT DOOR KEY CYLINDER SWITCH RH	D28	EL-D/LOCK, EL-THEFT
	FRONT DOOR LOCK ACTUATOR LH (DOOR UNLOCK SENSOR)	D10	EL-D/LOCK, EL-MULTI, EL-THEFT, EL-ROOM/L
FRONT DOOR LOCK ACTUATOR RH (DOOR UNLOCK SENSOR)	D29	EL-D/LOCK, EL-MULTI, EL-THEFT	
MAIN POWER WINDOW AND DOOR LOCK/UNLOCK SWITCH	D7	EL-D/LOCK, EL-WINDOW	
REAR DOOR LOCK ACTUATOR RH (DOOR UNLOCK SENSOR)	D53	EL-MULTI, EL-THEFT	
AIR BAG DIAGNOSIS SENSOR UNIT	Z2	RS-SRS	

GROUND DISTRIBUTION

GROUND	CONNECT TO	CONN. NO.	CELL CODE
E10/E34	AMBIENT TEMPERATURE SWITCH	E3	EC-FICD, HA-A/C
	ABS RELAY UNIT	E43	BR-ABS
	BRAKE FLUID LEVEL SWITCH	E51	EL-WARN
	COMBINATION SWITCH (FRONT FOG LAMP SWITCH)	E55	EL-F/FOG
	COOLING FAN MOTOR-1	E8	EC-COOL/F
	COOLING FAN MOTOR-2	E9	EC-COOL/F
	COOLING FAN RELAY-2 (HI-RELAY)	E16	EC-COOL/F
	COOLING FAN RELAY-3 (HI-RELAY)	E22	EC-COOL/F
	DAYTIME LIGHT CONTROL UNIT	E32	EL-DTRL
	FRONT COMBINATION LAMP LH (PARKING LAMP)	E33	EL-TAIL/L
	FRONT COMBINATION LAMP LH (TURN SIGNAL LAMP)	E33	EL-TURN
	FRONT COMBINATION LAMP RH (PARKING LAMP)	E11	EL-TAIL/L
	FRONT COMBINATION LAMP RH (TURN SIGNAL LAMP)	E11	EL-TURN
	FRONT FOG LAMP LH	E6	EL-F/FOG
	FRONT FOG LAMP RH	E1	EL-F/FOG
	HEADLAMP LH	E5	EL-H/LAMP, EL-THEFT
	HEADLAMP RH	E2	EL-H/LAMP, EL-DTRL, EL-THEFT
	HOOD SWITCH	E46	EL-THEFT
	INHIBITOR SWITCH	E204	AT-INH/SW, AT-NONDTTC, EL-ASCD, EL-START
	NEUTRAL POSITION SWITCH	E216	EC-PNP/SW
THEFT WARNING HORN RELAY	E21	EL-MULTI, EL-THEFT	
TRIPLE PRESSURE SWITCH	E7	HA-A/C	
WIPER SWITCH	E53	EL-WIPER	
E35	ABS CONTROL UNIT	E67	BR-ABS
E37	GENERATOR	E41	EL-CHARGE
E66	SHIELD WIRE (FRONT WHEEL SENSOR RH)	M62	BR-ABS
	SHIELD WIRE (FRONT WHEEL SENSOR LH)	E48	BR-ABS
	SHIELD WIRE (REAR WHEEL SENSOR LH)	B103	BR-ABS
	SHIELD WIRE (REAR WHEEL SENSOR RH)	B102	BR-ABS

GI
 MA
 EM
 LC
 EC
 FE
 CL
 MT
 AT
 FA
 RA
 BR
 ST
 RS
 BT
 HA
EL
 IDX

GROUND DISTRIBUTION

GROUND	CONNECT TO	CONN. NO.	CELL CODE
F2/F4	DATA LINK CONNECTOR FOR GST	M16	EC-MIL/DL
	SHIELD WIRE (KNOCK SENSOR)	E302	EC-KS
	DISTRIBUTOR	F9	EC-IGN/SG
	DISTRIBUTOR (CAMSHAFT POSITION SENSOR)	F9	EC-CMPS
	ECM (ECCS CONTROL MODULE)	F30	EC-MAIN
	REAR HEATED OXYGEN SENSOR	F24	EC-RRO2, EC-RRO2/H
	SHIELD WIRE (ABSOLUTE PRESSURE SENSOR)	F17	EC-AP/SEN
	SHIELD WIRE (CAMSHAFT POSITION SENSOR)	F9	EC-CMPS
	SHIELD WIRE (FRONT HEATED OXYGEN SENSOR)	F11	EC-FRO2, EC-FRO2/H, EC-FUEL
	SHIELD WIRE (MASS AIR FLOW SENSOR)	F15	EC-MAFS
	SHIELD WIRE (REAR HEATED OXYGEN SENSOR)	F24	EC-RRO2, EC-RRO2/H
	SHIELD WIRE (REVOLUTION SENSOR)	F14	AT-VSSA/T
	SHIELD WIRE (THROTTLE POSITION SENSOR)	F19	EC-TPS, AT-TPS
	SHIELD WIRE [CRANKSHAFT POSITION SENSOR (OBD)]	F12	EC-CKPS
	TRANSMISSION CONTROL MODULE	F29	AT-MAIN
	SHIELD WIRE (EVAP CONTROL SYSTEM PRESSURE SENSOR)	B28	EC-PRE/SE
B13/B19	FRONT DOOR SWITCH LH	B11	RS-SRS, EL-CHIME
	FUEL PUMP	B15	EC-F/PUMP
	FUEL TANK GAUGE UNIT	B14	EL-METER, EL-WARN
	FUEL TANK GAUGE UNIT (TANK FUEL TEMPERATURE SENSOR)	B14	EC-TFTS
	HIGH-MOUNTED STOP LAMP	B22	EL-STOP/L
	POWER SEAT	B9	EL-SEAT
	SEAT BELT BUCKLE SWITCH	B10	EL-CHIME, EL-WARN
	REAR DOOR LOCK ACTUATOR LH (DOOR UNLOCK SENSOR)	D43	EL-MULTI, EL-THEFT
B105	REAR WINDOW DEFOGGER	B104	EL-DEF
T6/T9	HIGH-MOUNTED STOP LAMP	T12	EL-STOP/L
	LICENSE PLATE LAMP LH	T7	EL-TAIL/L
	LICENSE PLATE LAMP RH	T8	EL-TAIL/L
	POWER ANTENNA	T11	EL-P/ANT
	REAR COMBINATION LAMP LH (BACK-UP LAMP)	T5	EL-BACK/L
	REAR COMBINATION LAMP LH (STOP LAMP)	T5	EL-STOP/L
	REAR COMBINATION LAMP LH (TAIL LAMP)	T5	EL-TAIL/L
	REAR COMBINATION LAMP LH (TURN SIGNAL LAMP)	T5	EL-TURN
	REAR COMBINATION LAMP RH (BACK-UP LAMP)	T10	EL-BACK/L
	REAR COMBINATION LAMP RH (STOP LAMP)	T10	EL-STOP/L
	REAR COMBINATION LAMP RH (TAIL LAMP)	T10	EL-TAIL/L
	REAR COMBINATION LAMP RH (TURN SIGNAL LAMP)	T10	EL-TURN
	TRUNK LID KEY CYLINDER SWITCH (UNLOCK SWITCH)	T3	EL-THEFT
	TRUNK ROOM LAMP SWITCH	T1	EL-INT/L, EL-THEFT

BATTERY

CAUTION:

If it becomes necessary to start the engine with a booster battery and jumper cables:

- Use a 12-volt booster battery.
- After connecting battery cables, ensure that they are tightly clamped to battery terminals for good contact.
- Never add distilled water through the hole used to check specific gravity.

GI

MA

EM

LC

EC

FE

CL

MT

AT

FA

RA

BR

ST

RS

BT

HA

EL

IDX

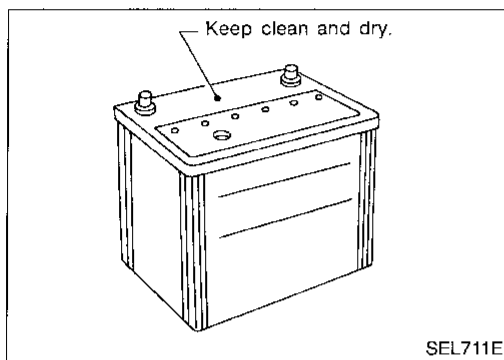

SEL711E

How to Handle Battery

METHODS OF PREVENTING OVER-DISCHARGE

The following precautions must be taken to prevent over-discharging a battery.

- The battery surface (particularly its top) should always be kept clean and dry.
- The terminal connections should be clean and tight.
- At every routine maintenance, check the electrolyte level.

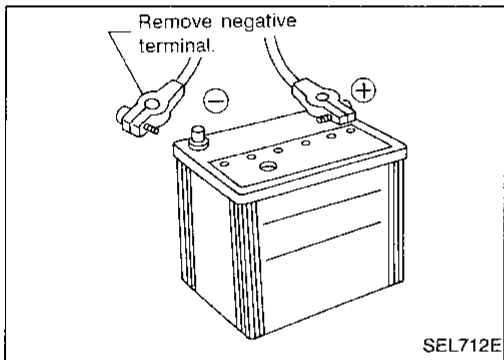

SEL712E

- When the vehicle is not going to be used over a long period of time, disconnect the negative battery terminal. (If the vehicle has an extended storage switch, turn it off.)

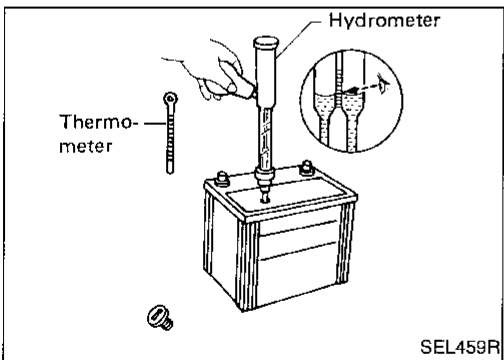

SEL459R

- Check the charge condition of the battery. Periodically check the specific gravity of the electrolyte. Keep a close check on charge condition to prevent overdischarge.

BATTERY

How to Handle Battery (Cont'd)

CHECKING ELECTROLYTE LEVEL

WARNING:

Do not allow battery fluid to come in contact with skin, eyes, fabrics, or painted surfaces. After touching a battery, do not touch or rub your eyes until you have thoroughly washed your hands. If the acid contacts the eyes, skin or clothing, immediately flush with water for 15 minutes and seek medical attention.

Normally the battery does not require additional water. However, when the battery is used under severe conditions, adding distilled water may be necessary during the battery life.

- Remove the cell plug using a suitable tool.
- Add distilled water up to the MAX level.

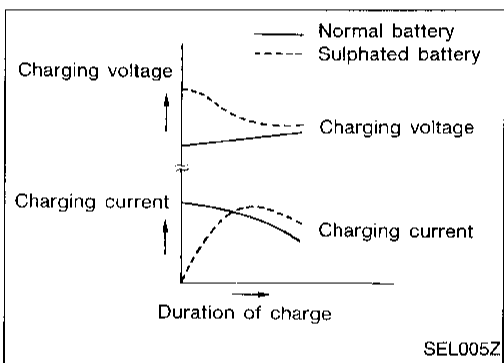
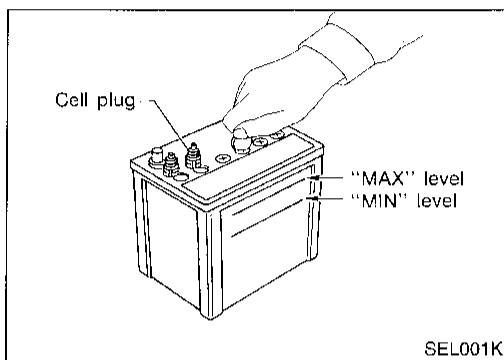

SULPHATION

A battery will be completely discharged if it is left unattended for a long time and the specific gravity becomes less than 1.100. This may result in sulphation on the cell plates.

To determine if a battery has been "sulphated", note its voltage and current when charging it. As shown in the figure, less current and higher voltage are observed in the initial stage of charging sulphated batteries.

A sulphated battery may sometimes be brought back into service by means of a long, slow charge, 12 hours or more, followed by a battery capacity test.

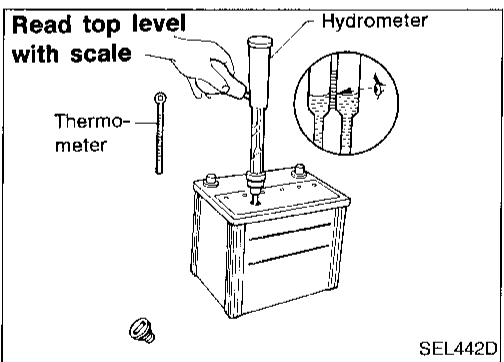

SPECIFIC GRAVITY CHECK

1. Read hydrometer and thermometer indications at eye level.

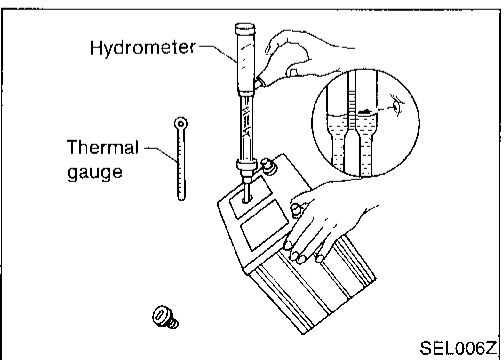

- When electrolyte level is too low, tilt battery case to raise it for easy measurement.

BATTERY

How to Handle Battery (Cont'd)

2. Use the chart below to correct your hydrometer reading according to electrolyte temperature.

Hydrometer temperature correction

Battery electrolyte temperature °C (°F)	Add to specific gravity reading
71 (160)	0.032
66 (150)	0.028
60 (140)	0.024
54 (129)	0.020
49 (120)	0.016
43 (110)	0.012
38 (100)	0.008
32 (90)	0.004
27 (80)	0
21 (70)	-0.004
16 (60)	-0.008
10 (50)	-0.012
4 (39)	-0.016
-1 (30)	-0.020
-7 (20)	-0.024
-12 (10)	-0.028
-18 (0)	-0.032

Corrected specific gravity	Approximate charge condition
1.260 - 1.280	Fully charged
1.230 - 1.250	3/4 charged
1.200 - 1.220	1/2 charged
1.170 - 1.190	1/4 charged
1.140 - 1.160	Almost discharged
1.110 - 1.130	Completely discharged

GI

MA

EM

LC

EC

FE

CL

MT

AT

FA

RA

BR

ST

RS

BT

HA

EL

IDX

BATTERY

How to Handle Battery (Cont'd)

CHARGING THE BATTERY

CAUTION:

- Do not "quick charge" a fully discharged battery.
- Keep the battery away from open flame while it is being charged.
- When connecting the charger, connect the leads first, then turn on the charger. Do not turn on the charger first, as this may cause a spark.
- If battery electrolyte temperature rises above 60°C (140°F), stop charging. Always charge battery at a temperature below 60°C (140°F).

Charging rates

Amps	Time
50	1 hour
25	2 hours
10	5 hours
5	10 hours

Do not charge at more than 50 ampere rate.

Note: The ammeter reading on your battery charger will automatically decrease as the battery charges. This indicates that the voltage of the battery is increasing normally as the state of charge improves. The charging amps indicated above refer to initial charge rate.

- If, after charging, the specific gravity of any two cells varies more than .050, the battery should be replaced.
- After the battery is charged, always perform a capacity test to assure that the battery is serviceable.

Service Data and Specifications (SDS)

Applied area		USA	Canada
Type		55D23R	65D26R
Capacity	V-AH	12-60	12-65
Cold cranking current (For reference value)	A	356	413

System Description

M/T MODELS

Power is supplied at all times:

- to ignition switch terminal **B**
- through 40A fusible link (letter **g**), located in the fuse and fusible link box).

With the ignition switch in the START position, power is supplied:

- through terminal **57** of the ignition switch
- to clutch interlock relay terminal **3**.

For models with theft warning system

With the ignition switch in the ON or START position, power is supplied:

- through 10A fuse [No. **25**, located in the fuse block (J/B)]
- to theft warning relay terminal **1**.

With the ignition switch in the START position, power is supplied:

- through 10A fuse [No. **26**, located in the fuse block (J/B)]
- to theft warning relay terminal **3**.

If the theft warning system is triggered, terminal **2** of the theft warning relay is grounded through terminal **32** of the smart entrance control unit and power to the clutch interlock relay is interrupted.

When the theft warning system is not operating, power is supplied:

- through theft warning relay terminal **4**
- to clutch interlock relay terminal **1**.

For models without theft warning system

With the ignition switch in the START position, power is supplied:

- through 10A fuse [No. **26**, located in the fuse block (J/B)]
- to clutch interlock relay terminal **1**.

Ground is supplied to clutch interlock relay terminal **2**, when the clutch pedal is depressed through the clutch interlock switch and body grounds **M2** and **M61**.

The clutch interlock relay is energized and power is supplied:

- from terminal **5** of the clutch interlock relay
- to terminal **2** of the starter motor windings.

The starter motor plunger closes and provides a closed circuit between the battery and the starter motor. The starter motor is grounded to the engine block. With power and ground supplied, cranking occurs and the engine starts.

GI

MA

EM

LC

EC

FE

CL

MT

AT

FA

RA

BR

ST

RS

BT

HA

EL

IDX

STARTING SYSTEM

System Description (Cont'd)

A/T MODELS

Power is supplied at all times:

- through 40A fusible link (letter **g**), located in the fuse and fusible link box)
- to ignition switch terminal **B**.

For models with theft warning system

With the ignition switch in the ON or START position, power is supplied:

- through 10A fuse [No. **25**, located in the fuse block (J/B)]
- to theft warning relay terminal **1**
- to theft warning relay terminal **3**
- through theft warning relay terminal **4**
- to inhibitor relay terminal **1**.

If the theft warning system is triggered, terminal **2** of the theft warning relay is grounded through smart entrance control unit terminal **32** and power to the inhibitor relay is interrupted.

When the theft warning system is not triggered and the ignition switch is in the START position, power is supplied:

- from ignition switch terminal **5T**
- to inhibitor relay terminal **6**.

With the selector lever in the "P" or "N" position, ground is supplied:

- from inhibitor switch terminal **1**
- to inhibitor relay terminal **2**
- through inhibitor switch terminal **2**
- to body grounds **E10** and **E34**.

The inhibitor relay is energized, and power is supplied:

- from inhibitor relay terminal **7**
- to terminal **2** of the starter motor windings.

The starter motor plunger closes and provides a closed circuit between the battery and starter motor. The starter motor is grounded to the engine block. With power and ground supplied, cranking occurs and the engine starts.

For models without theft warning system

With the ignition switch in the ON or START position, power is supplied:

- through 10A fuse [No. **25**, located in the fuse block (J/B)]
- to inhibitor relay terminal **1**.

With the ignition switch in the START position, power is supplied:

- from ignition switch terminal **5T**
- to inhibitor relay terminal **6**.

With the selector lever in the "P" or "N" position, ground is supplied:

- from inhibitor switch terminal **1**
- to inhibitor relay terminal **2**
- through inhibitor switch terminal **2**
- to body grounds **E10** and **E34**.

The inhibitor relay is energized and power is supplied:

- from inhibitor relay terminal **7**
- to terminal **2** of the starter motor windings.

The starter motor plunger closes and provides a closed circuit between the battery and starter motor. The starter motor is grounded to the engine block. With power and ground supplied, cranking occurs and the engine starts.

THEFT WARNING SYSTEM

The theft warning system will interrupt power supply to clutch interlock relay (M/T models) or inhibitor relay (A/T models) if the system is triggered. The starter motor will then not crank, and the engine will not start. Refer to "THEFT WARNING SYSTEM" (EL-197).

STARTING SYSTEM

Wiring Diagram — START —

M/T MODELS

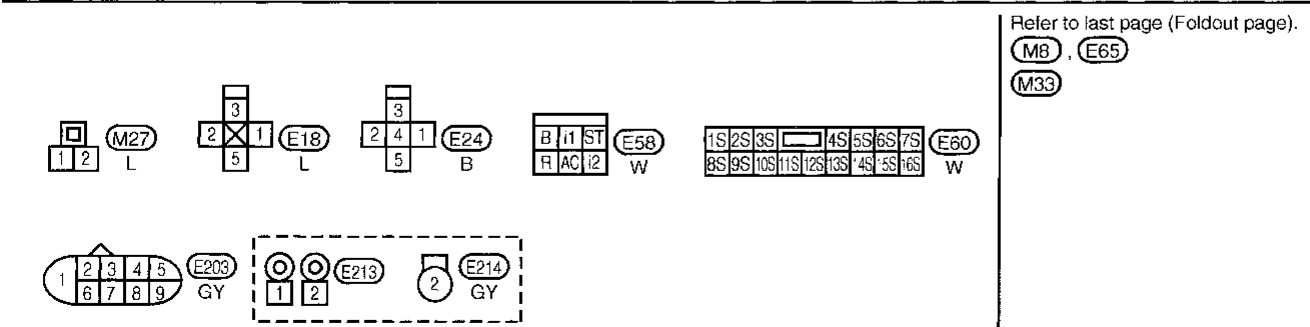
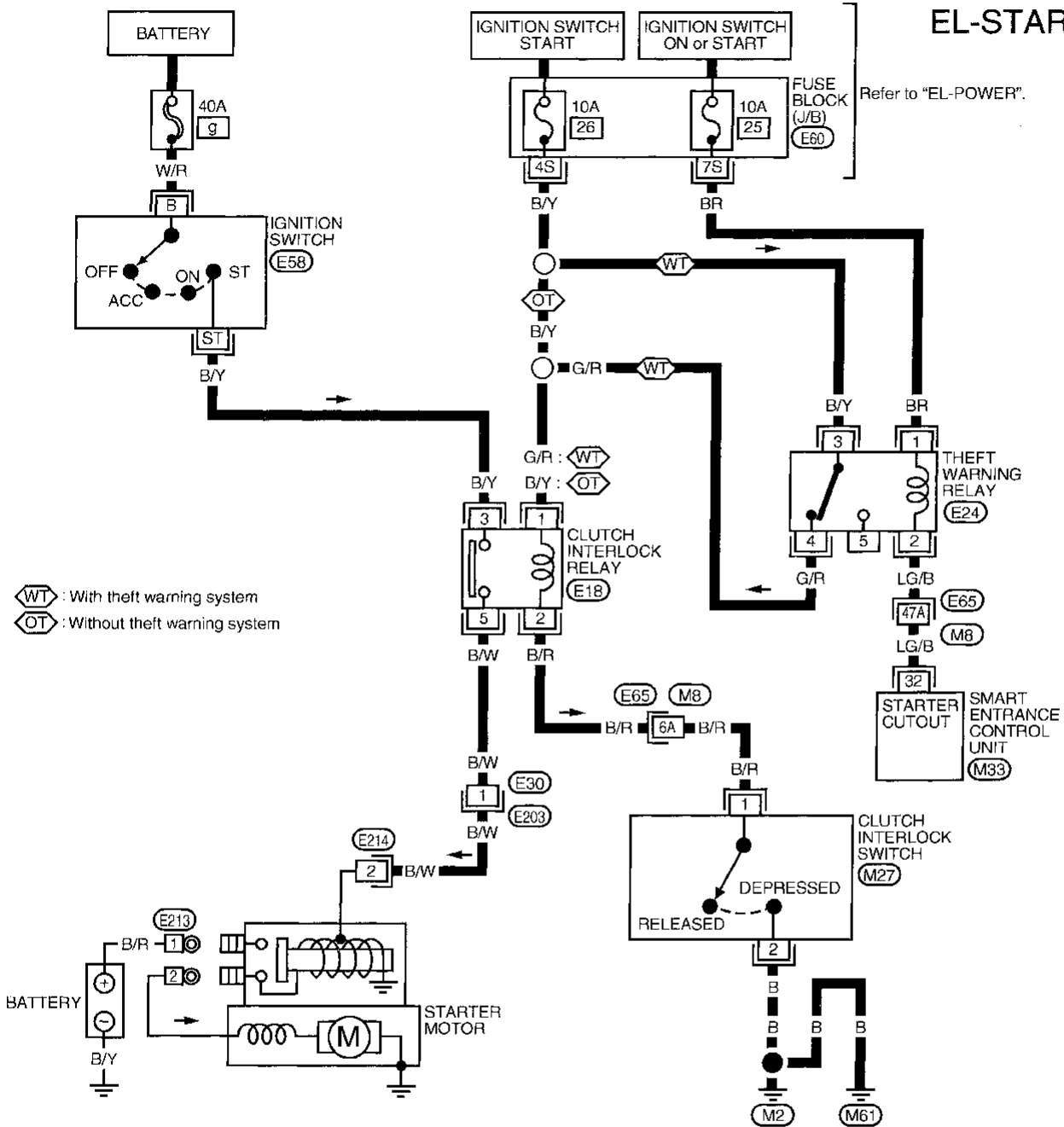

GI
 MA
 EM
 LC
 EC
 FE
 CL
 WT
 AT
 FA
 RA
 BR
 ST
 RS
 BT
 HA
EL
 IDX

STARTING SYSTEM

Wiring Diagram — START — (Cont'd)

A/T MODELS

EL-START-02

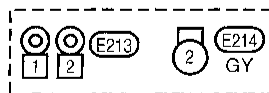
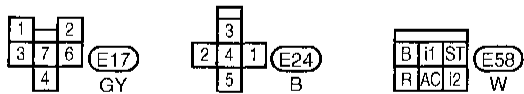
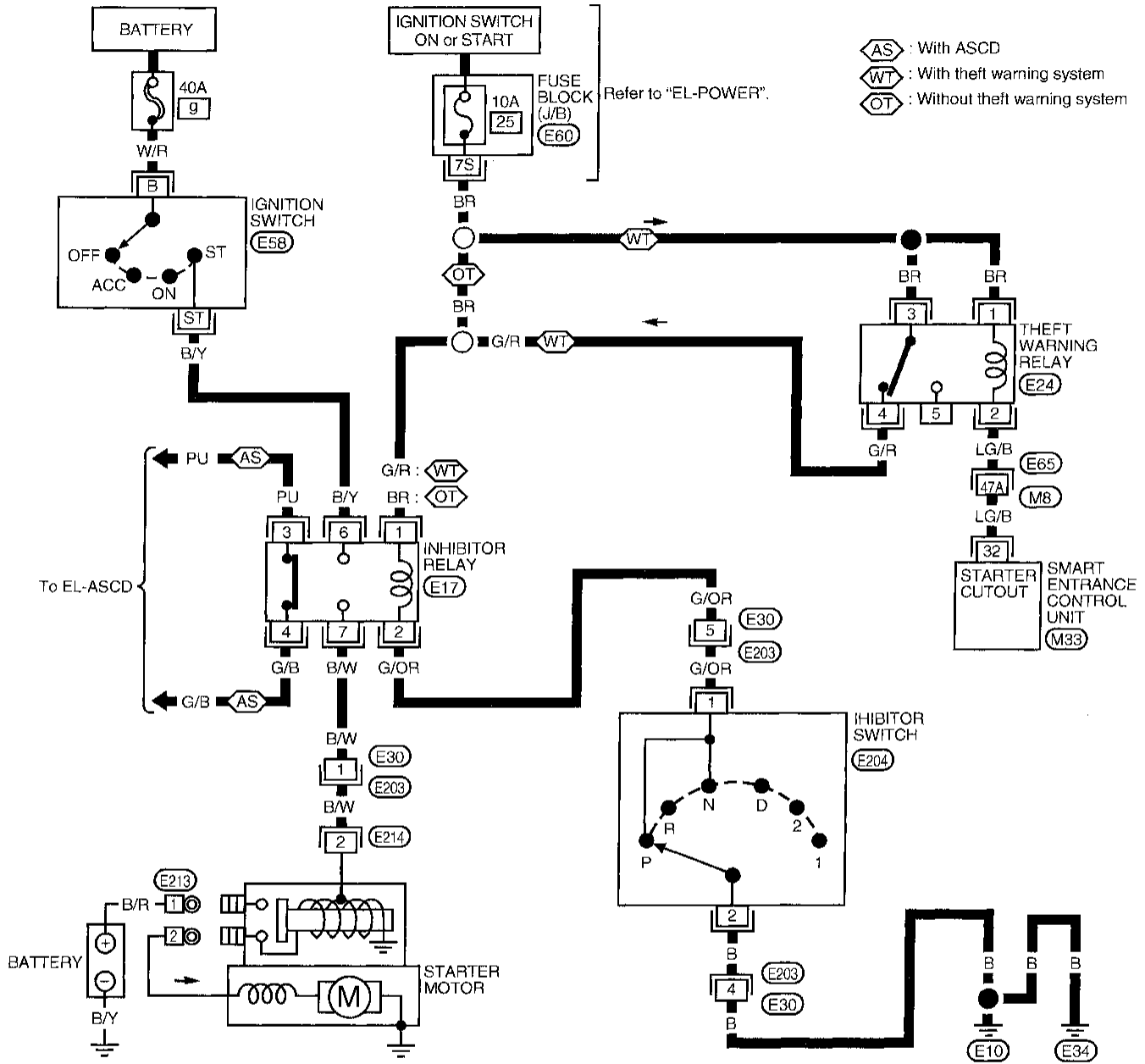

Refer to last page (Foldout page).

(M8) (E65)
(M33)

STARTING SYSTEM

Construction

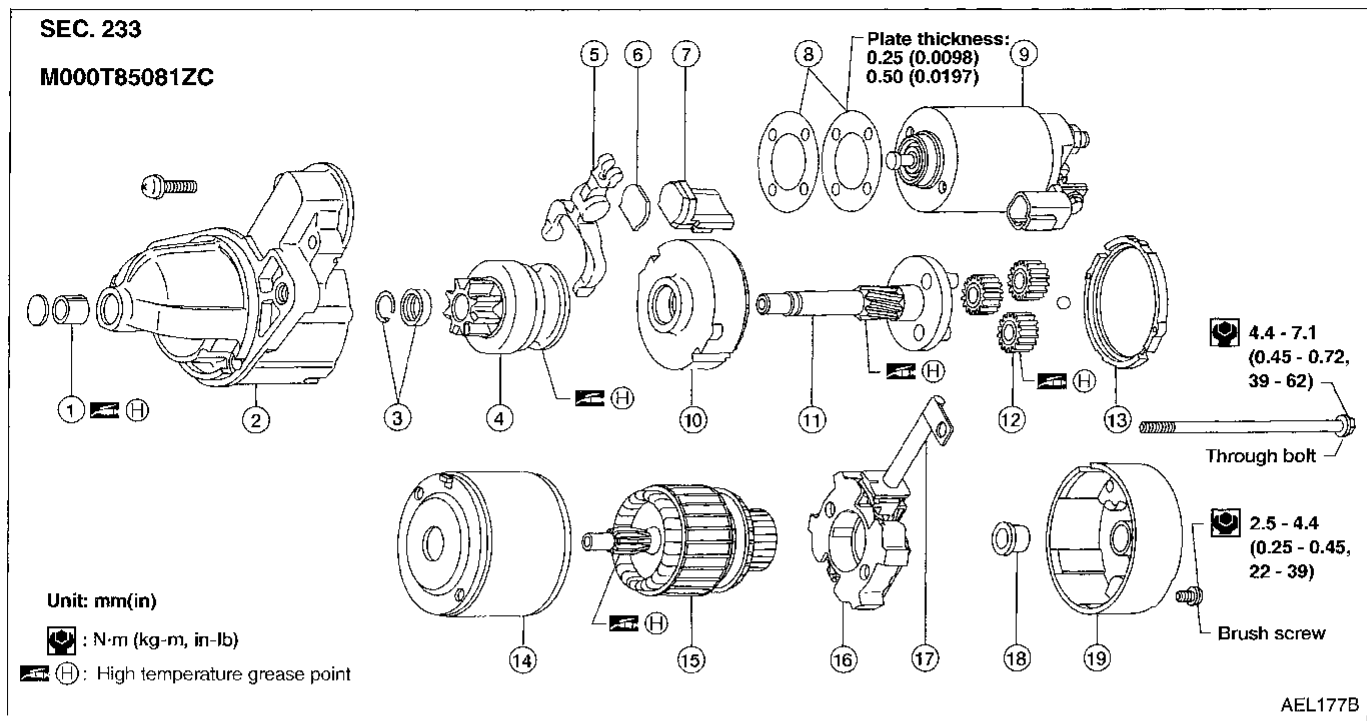

- | | | |
|-------------------|----------------------------|-----------------------------------|
| ① Sleeve bearing | ⑧ Adjusting plate | ⑮ Armature |
| ② Gear case | ⑨ Magnetic switch assembly | ⑯ Connector brush holder assembly |
| ③ Pinion stopper | ⑩ Internal gear | ⑰ Brush (+) |
| ④ Pinion assembly | ⑪ Shaft | ⑱ Brush spring |
| ⑤ Shift lever | ⑫ Planetary gear | ⑲ Rear cover |
| ⑥ Plate | ⑬ Packing | |
| ⑦ Packing | ⑭ Yoke | |

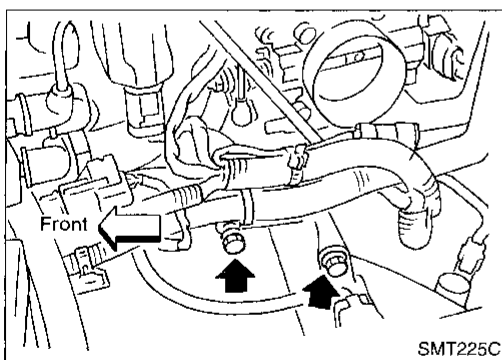

Removal and Installation

REMOVAL

1. Remove air inlet tube.
2. Remove harness bracket.
3. Disconnect starter.
4. Remove two bolts and starter.

INSTALLATION

To install, reverse the removal procedure.

Pinion/Clutch Check

1. Inspect pinion teeth.
 - Replace pinion if teeth are worn or damaged. (Also check condition of ring gear teeth.)
2. Inspect reduction gear teeth.
 - Replace reduction gear if teeth are worn or damaged. (Also check condition of armature shaft gear teeth.)
3. Check to see if pinion locks in one direction and rotates smoothly in the opposite direction.
 - If it locks or rotates in both directions, or unusual resistance is evident, replace.

STARTING SYSTEM

Service Data and Specifications (SDS)

STARTER

Type		M000T85081ZC
		MELMAC
		Reduction gear type
Applied model		All
System voltage	V	12
No-load		
Terminal voltage	V	11.0
Current	A	Less than 90
Revolution	rpm	More than 2,500
Minimum diameter of commutator		
	mm (in)	28.8 (1.134)
Minimum length of brush		
	mm (in)	12.0 (0.472)
Brush spring tension		
	N (kg, lb)	13.7 - 25.5 (1.4 - 2.6, 3.1 - 5.7)
Clearance of bearing metal and armature shaft		
	mm (in)	—
Clearance "t" between pinion front edge and pinion stopper		
	mm (in)	0.5 - 2.0 (0.020 - 0.079)
Installed current	A	140

CHARGING SYSTEM

System Description

The generator provides DC voltage to operate the vehicle's electrical system and to keep the battery charged. The voltage output is controlled by the IC regulator.

Power is supplied at all times to generator terminal ④ through:

- 100A fusible link (letter **e**, located in the fuse and fusible link box), and
- 10A fuse (No. **38**, located in the fuse and fusible link box).

Terminal ① supplies power to charge the battery and operate the vehicle's electrical system. Output voltage is controlled by the IC regulator at terminal ④ detecting the input voltage. The charging circuit is protected by the 100A fusible link.

Terminal ② of the generator supplies ground through body ground **(E37)**.

With the ignition switch in the ON or START position, power is supplied:

- through 10A fuse [No. **12**, located in the fuse block (J/B)]
- to combination meter terminal **④3** for the charge warning lamp.

Ground is supplied to terminal **④4** of the combination meter through terminal **③** of the generator. With power and ground supplied, the charge warning lamp will illuminate. When the generator is providing sufficient voltage with the engine running, the ground is opened and the charge warning lamp will go off. If the charge warning lamp illuminates with the engine running, a fault is indicated.

GI

MA

EM

LC

EC

FE

CL

MT

AT

FA

RA

BR

ST

RS

BT

HA

EL

IDX

CHARGING SYSTEM

Wiring Diagram — CHARGE —

EL-CHARGE-01

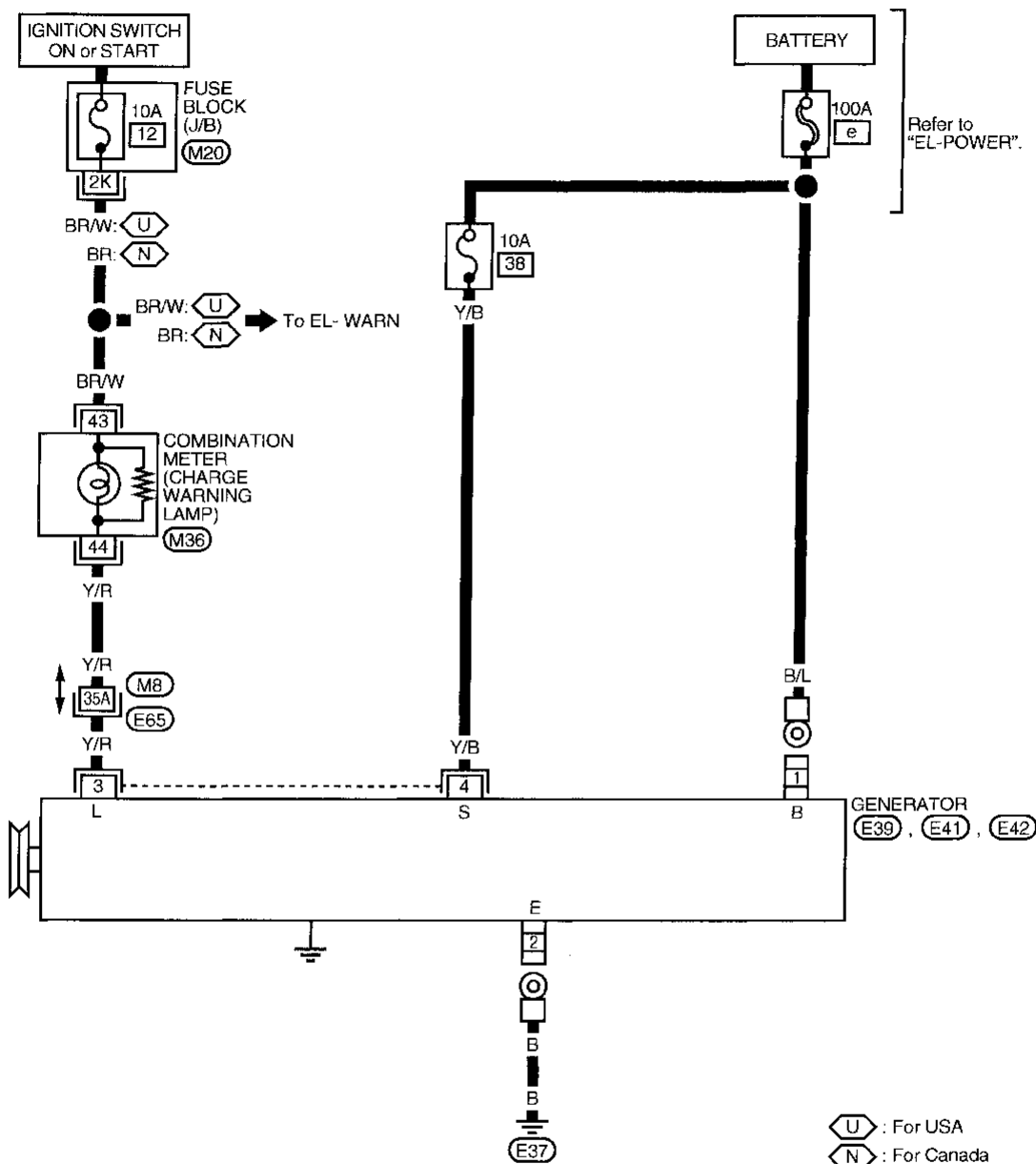

Refer to last page (Foldout page).

M8, E65

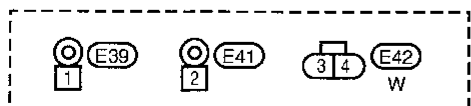
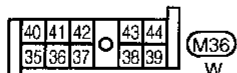

CHARGING SYSTEM

Trouble Diagnoses

Before conducting a generator test, make sure that the battery is fully charged. A 30-volt voltmeter and suitable test probes are necessary for the test. The generator can be checked easily by referring to the Inspection Table.

- Before starting, inspect the fusible link.
- Use fully charged battery.

WITH IC REGULATOR

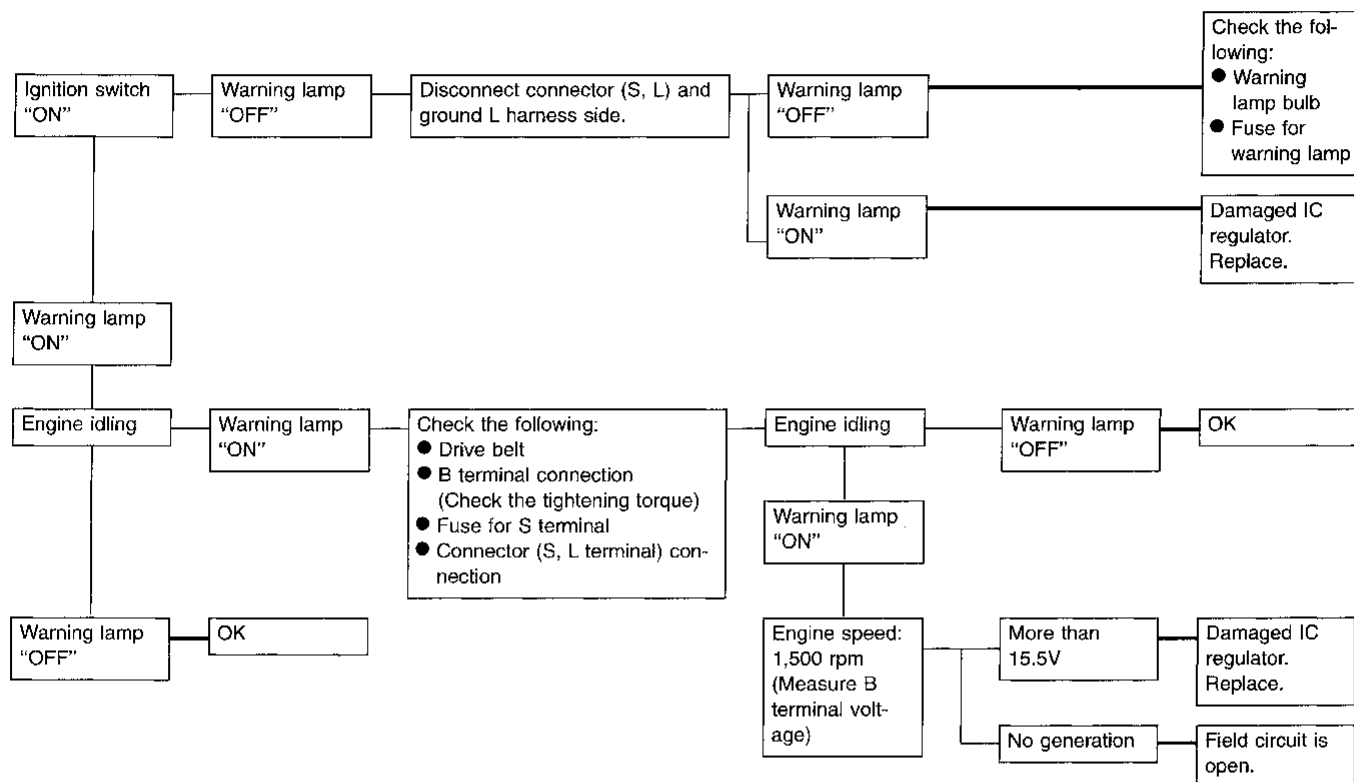

Warning lamp: "CHARGE" warning lamp in combination meter

Note:

★: When field circuit is open, check condition of rotor coil, rotor slip ring and brush. If necessary, replace faulty parts with new ones.

MALFUNCTION INDICATOR

The IC regulator warning function activates to illuminate "CHARGE" warning lamp, if any of the following symptoms occur while generator is operating:

- Excessive voltage is produced.
- B Terminal is disconnected.
- S Terminal is disconnected or related circuit is open.
- Field circuit is open.

CHARGING SYSTEM

Construction

SEC. 231
LR1100-709B

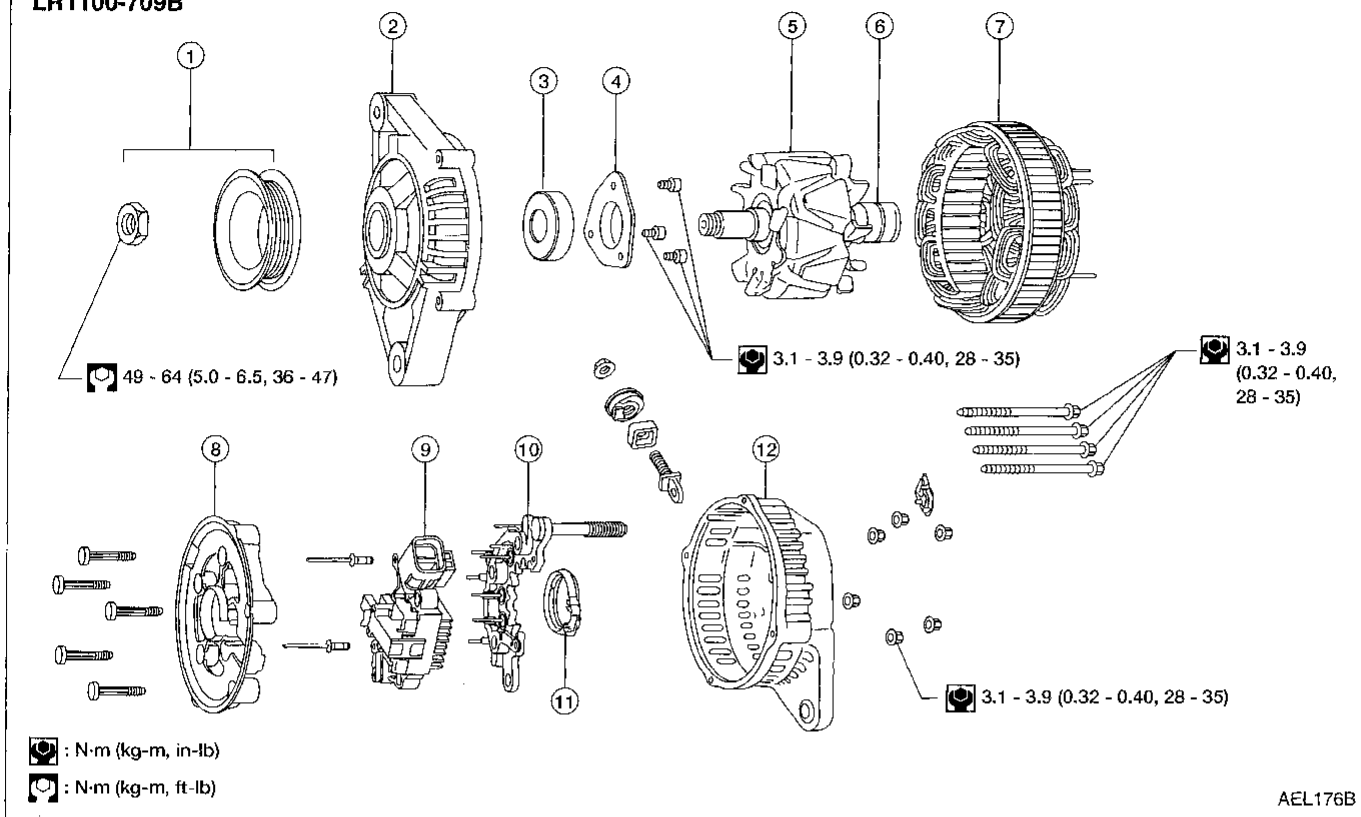

AEL176B

- ① Pulley assembly
- ② Front cover
- ③ Front bearing
- ④ Retainer

- ⑤ Rotor
- ⑥ Slip ring
- ⑦ Stator
- ⑧ Fan guide

- ⑨ IC regulator assembly
- ⑩ Diode assembly
- ⑪ Packing
- ⑫ Rear cover

CHARGING SYSTEM

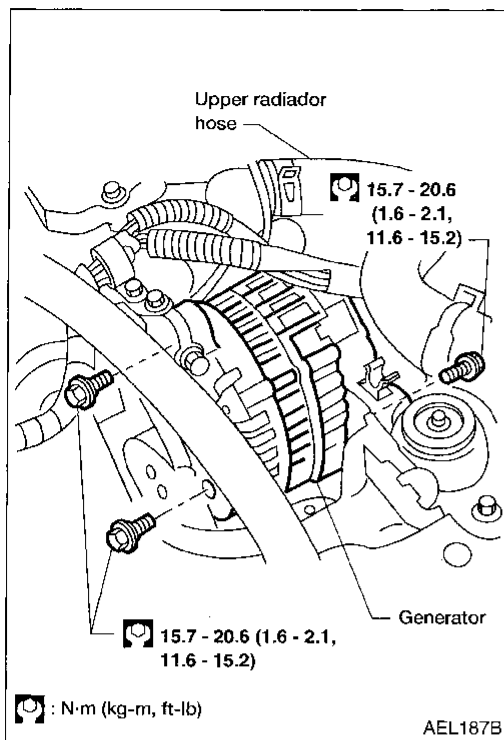

Removal and Installation

REMOVAL

1. Remove upper radiator hose.
2. Disconnect harness connectors, harness stay and harness to A/C compressor.
3. Release accelerator wire.
4. Back off adjustment bolt, remove belt.
5. Remove three generator bolts and generator.

INSTALLATION

To install, reverse the removal procedure.

Service Data and Specifications (SDS)

GENERATOR

Type		LR1100-709B
		HAP
Nominal rating	V-A	12-100
Ground polarity		Negative
Minimum revolution under no-load (When 13.5 volts is applied)	rpm	Less than 1,000
Hot output current (When 13.5 volts is applied)	A/rpm	More than 24/1,300 More than 71/2,500 More than 98/5,000
Regulated output voltage	V	14.1 - 14.7
Minimum length of brush	mm (in)	6.00 (0.236)
Brush spring pressure	N (g, oz)	1.000 - 2.432 (102 - 250, 3.60 - 8.82)
Slip ring minimum diameter	mm (in)	26.0 (1.024)
Rotor (field coil) resistance	Ω	2.05

GI

MA

EM

LC

EC

FE

CL

MT

AT

FA

RA

BR

ST

RS

BT

HA

EL

IDX

COMBINATION SWITCH

Combination Switch/Check

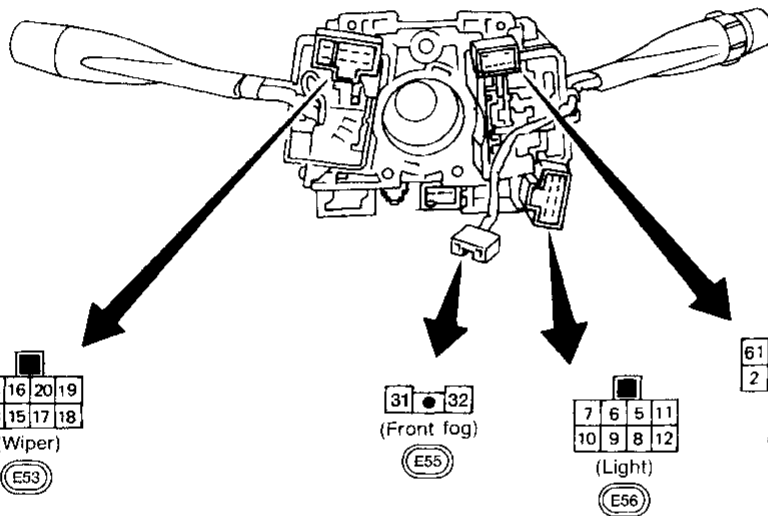
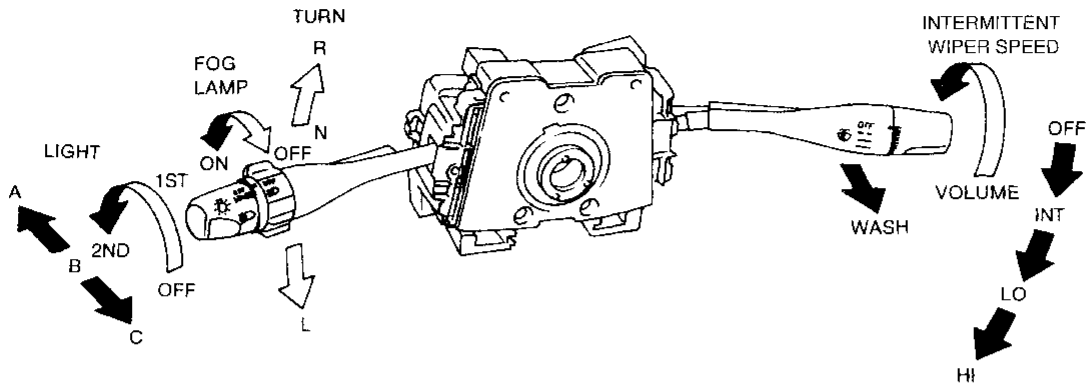

LIGHTING SWITCH

	OFF			1ST			2ND		
	A	B	C	A	B	C	A	B	C
5			○			○	○	○	○
6		○			○	○		○	
7									○
8		○			○	○	○	○	○
9		○			○	○	○	○	○
10									○
11			○	○	○	○	○	○	○
12				○	○	○	○	○	○

WIPER SWITCH

	OFF	INT	LO	HI	WASH
13	○	○			
14	○	○	○		
15		○			
16				○	
17		○	○	○	○
18					○

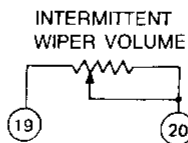

TURN SIGNAL SWITCH

	R	N	L
1	○		○
2	○		○
3			

FRONT FOG LAMP SWITCH

	OFF	ON
31		○
32		○

COMBINATION SWITCH

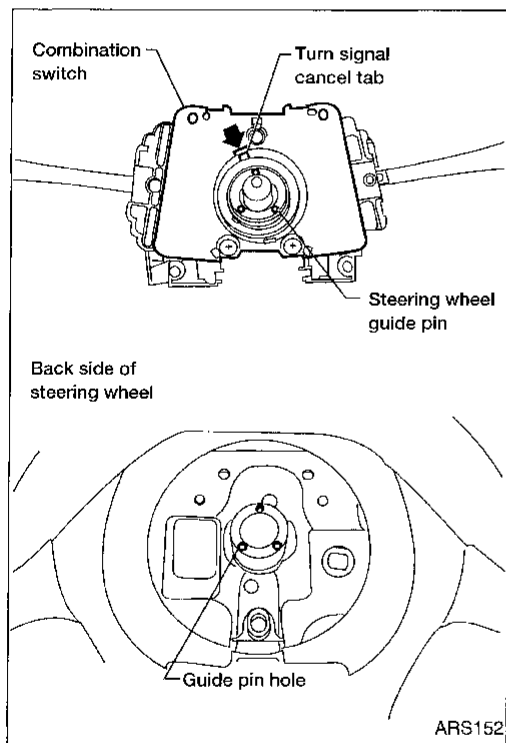
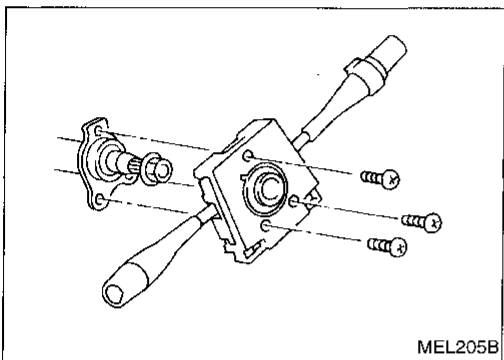
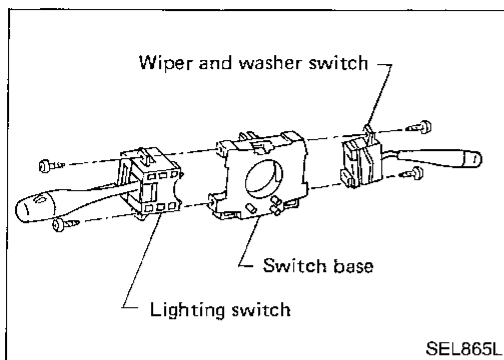

Replacement

For removal and installation of spiral cable, refer to RS section ["Driver — Air Bag Module and Spiral Cable", "SUPPLEMENTAL RESTRAINT SYSTEM (SRS)"].

- Each switch can be replaced without removing combination switch base.

- To remove combination switch base, remove base attaching screws.

- Before installing the steering wheel, align the turn signal cancel tab with the notch of combination switch. Refer to RS section ("INSTALLATION", "Driver Air Bag Module and Spiral Cable").

GI

MA

EM

LC

EC

FE

CL

MT

AT

FA

RA

BR

ST

RS

BT

HA

EL

IDX

COMBINATION SWITCH

Steering Switch/Check

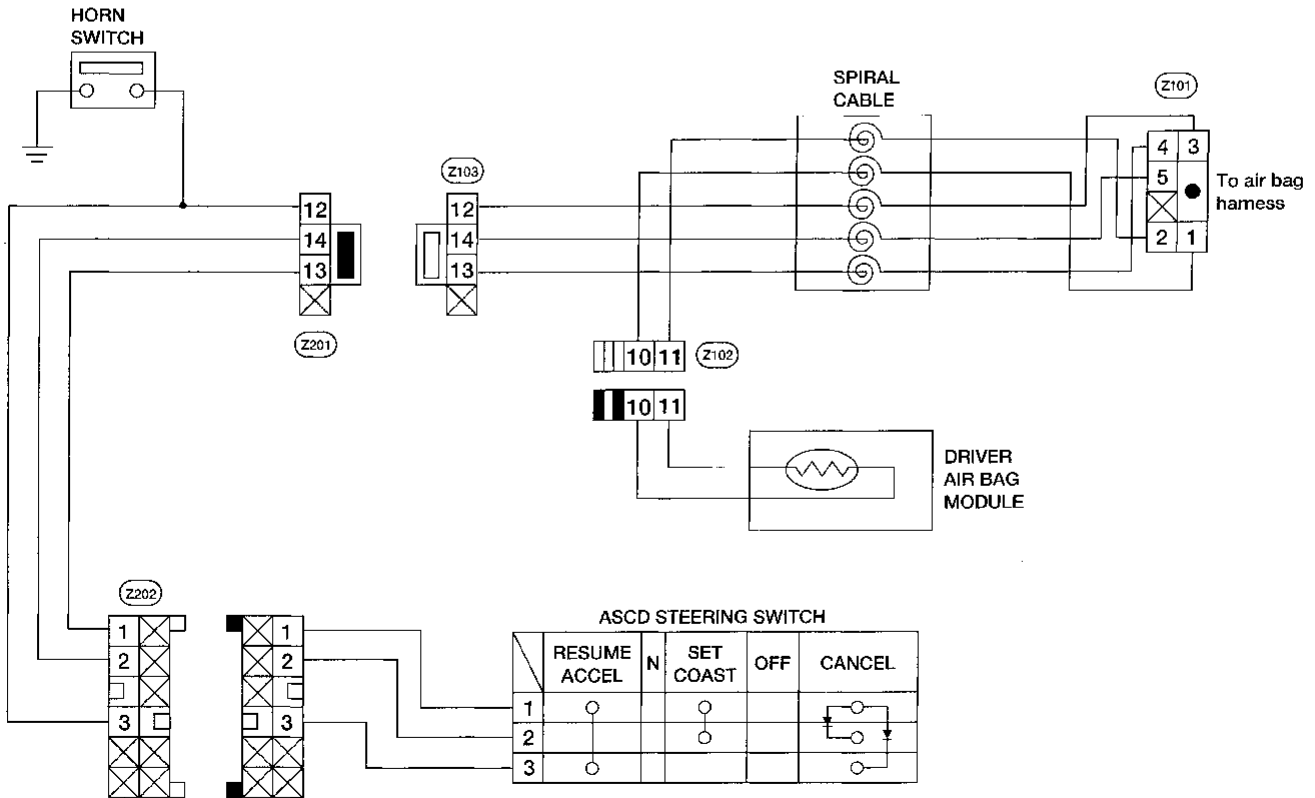
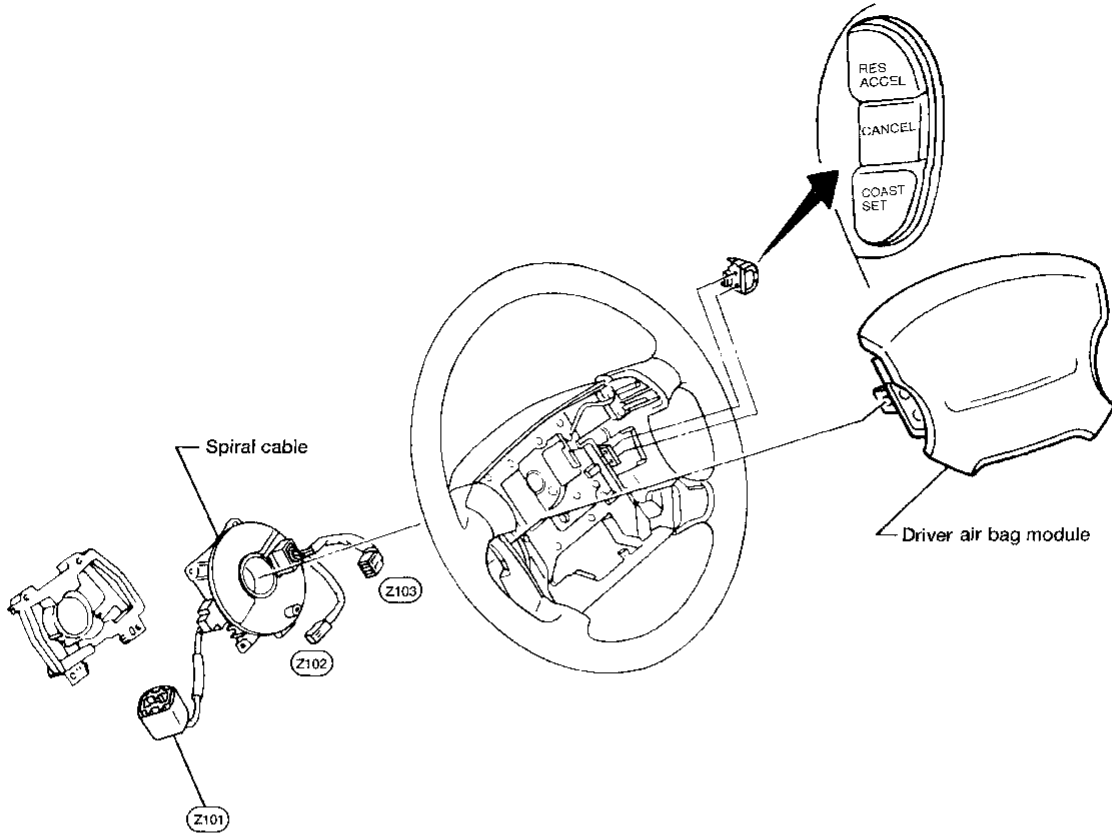

System Description (For USA)

The headlamps are controlled by the lighting switch which is built into the combination switch. Power is supplied at all times:

- to lighting switch terminal ⑤
- through 15A fuse (No. ③③, located in the fuse and fusible link box), and
- to lighting switch terminal ⑧
- through 15A fuse (No. ③②, located in the fuse and fusible link box).

Low beam operation

When the lighting switch is turned to headlamp "ON" (2ND) position, "LOW BEAM" (B), power is supplied:

- from lighting switch terminal ⑩
- to terminal ①⑨ of the LH headlamp, and
- from lighting switch terminal ⑦
- to terminal ①⑨ of the RH headlamp.

Terminal ⑤ of each headlamp supplies ground through body grounds ⑤⑩ and ⑤③④.

With power and ground supplied, the headlamp(s) will illuminate.

High beam operation/flash-to-pass operation

When the lighting switch is turned to headlamp "ON" (2ND) position, "HIGH BEAM" (A) or "FLASH TO PASS" (C) position, power is supplied:

- from lighting switch terminal ⑥
- to terminal ①① of RH headlamp, and
- from lighting switch terminal ⑨
- to terminal ①① of LH headlamp, and
- to combination meter terminal ①① for the high beam indicator.

Ground is supplied to terminal ⑩ of the combination meter through body grounds ①② and ①⑥①.

Terminal ⑤ of each headlamp supplies ground through body grounds ⑤⑩ and ⑤③④.

With power and ground supplied, the high beams and the high beam indicator illuminate.

Theft warning system

The theft warning system will flash the high beams if the system is triggered. Refer to "THEFT WARNING SYSTEM" (EL-197).

GI

MA

EM

LC

EC

FE

GL

MT

AT

FA

RA

BR

ST

RS

BT

HA

EL

IDX

HEADLAMP

Wiring Diagram (For USA) — H/LAMP —

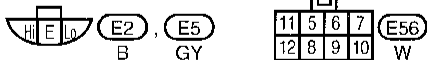
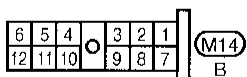
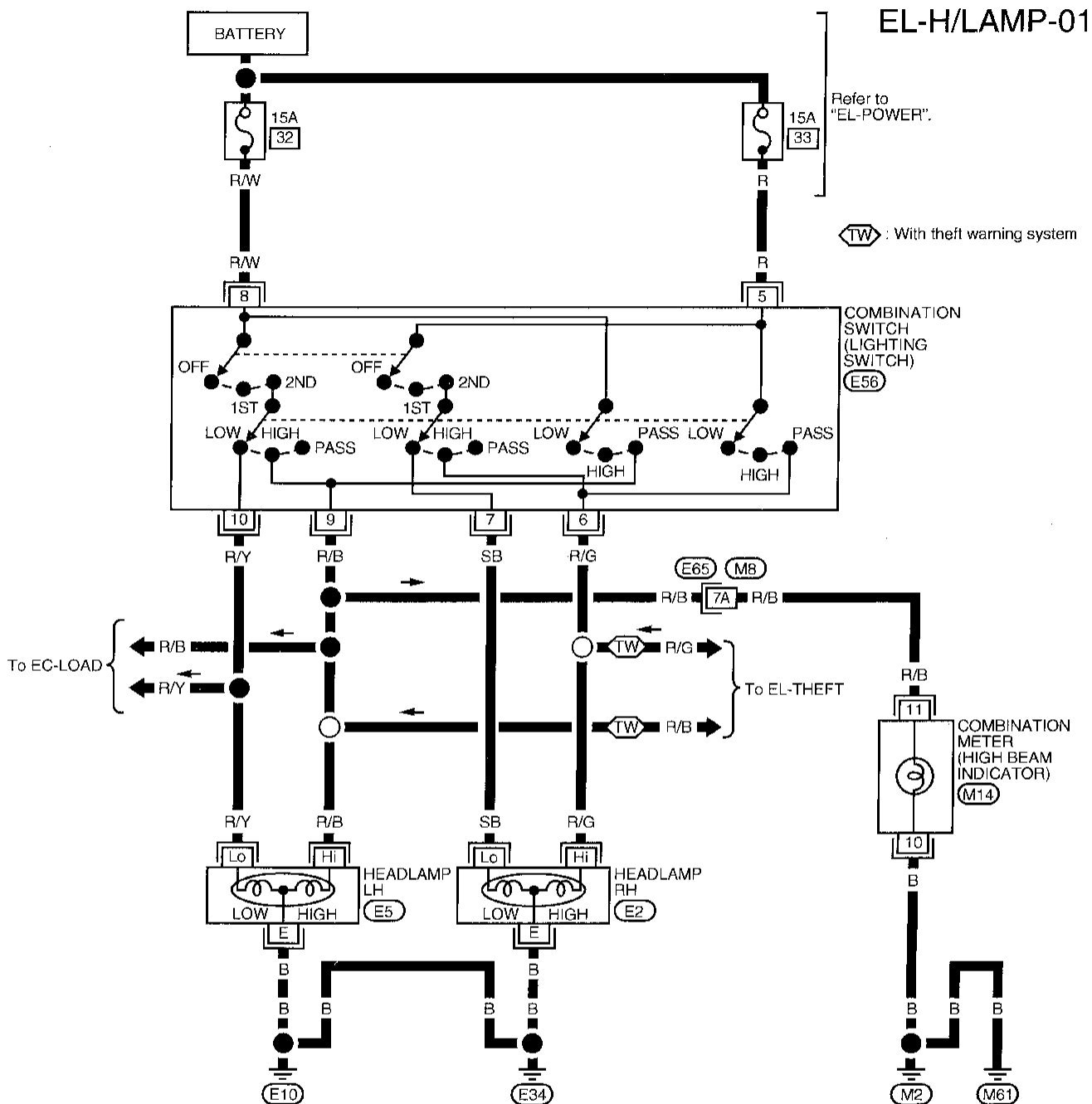

HEADLAMP

Trouble Diagnoses

Symptom	Possible cause	Repair order
LH headlamps do not operate.	<ol style="list-style-type: none"> 1. Bulb 2. Grounds (E10) and (E34) 3. 15A fuse 4. Lighting switch 	<ol style="list-style-type: none"> 1. Check bulb. 2. Check grounds (E10) and (E34) . 3. Check 15A fuse (No. 32), located in fuse and fusible link box). Verify battery positive voltage is present at terminal (8) of lighting switch. 4. Check lighting switch.
RH headlamps do not operate.	<ol style="list-style-type: none"> 1. Bulb 2. Grounds (E10) and (E34) 3. 15A fuse 4. Lighting switch 	<ol style="list-style-type: none"> 1. Check bulb. 2. Check grounds (E10) and (E34) . 3. Check 15A fuse (No. 33), located in fuse and fusible link box). Verify battery positive voltage is present at terminal (5) of lighting switch. 4. Check lighting switch.
LH high beams do not operate, but LH low beam operates.	<ol style="list-style-type: none"> 1. Bulbs 2. Open in LH high beams circuit 3. Lighting switch 	<ol style="list-style-type: none"> 1. Check bulbs. 2. Check R/B wire between lighting switch and LH headlamps for an open circuit. 3. Check lighting switch.
LH low beam does not operate, but LH high beam operates.	<ol style="list-style-type: none"> 1. Bulb 2. Open in LH low beam circuit 3. Lighting switch 	<ol style="list-style-type: none"> 1. Check bulb. 2. Check R/Y wire between lighting switch and LH headlamp for an open circuit. 3. Check lighting switch.
RH high beams do not operate, but RH low beam operates.	<ol style="list-style-type: none"> 1. Bulbs 2. Open in RH high beams circuit 3. Lighting switch 	<ol style="list-style-type: none"> 1. Check bulbs. 2. Check R/G wire between lighting switch and RH headlamps for an open circuit. 3. Check lighting switch.
RH low beam does not operate, but RH high beam operates.	<ol style="list-style-type: none"> 1. Bulb 2. Open in RH low beam circuit 3. Lighting switch 	<ol style="list-style-type: none"> 1. Check bulb. 2. Check SB wire between lighting switch and RH headlamp for an open circuit. 3. Check lighting switch.
High beam indicator does not work.	<ol style="list-style-type: none"> 1. Bulb 2. Grounds (M2) and (M61) 3. Open in high beam circuit 	<ol style="list-style-type: none"> 1. Check bulb in combination meter. 2. Check grounds (M2) and (M61) . 3. Check R/B wire between lighting switch and combination meter for an open circuit.

GI

MA

EM

LC

EC

FE

CL

MT

AT

FA

RA

BR

ST

RS

BT

HA

EL

IDX

HEADLAMP

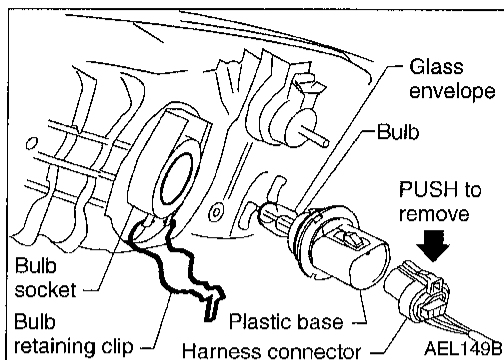

Bulb Replacement

The headlamp is a semi-sealed beam type which uses a replaceable halogen bulb. The bulb can be replaced from the engine compartment side without removing the headlamp body.

- **Grasp only the plastic base when handling the bulb. Never touch the glass envelope.**

1. Disconnect the battery cable.
2. Disconnect the harness connector from the back side of the bulb.
3. Unclip the bulb retaining clip, and then remove it.
4. Remove the headlamp bulb carefully. Do not shake or rotate the bulb when removing it.
5. Install in the reverse order of removal.

CAUTION:

- **Do not leave headlamp reflector without bulb for a long period of time. Dust, moisture, smoke, etc. entering headlamp body may affect the performance of the headlamp. Remove headlamp bulb from the headlamp reflector just before a replacement bulb is installed.**

Aiming Adjustment

When performing headlamp aiming adjustment, use an aiming machine, aiming wall screen or headlamp tester. Aimers should be in good repair, calibrated and operated in accordance with respective operation manuals.

If any aimer is not available, aiming adjustment can be done as follows:

For details, refer to the regulations in your own country.

- a. **Keep all tires inflated to correct pressures.**
- b. **Place vehicle and tester on one and same flat surface.**
- c. **See that there is no-load in vehicle (coolant, engine oil filled up to correct level and full fuel tank) other than the driver (or equivalent weight placed in driver's position).**

HEADLAMP

Aiming Adjustment (Cont'd)

AIMER ADJUSTMENT MARK

When using a mechanical aimer, adjust adapter legs to the data marked on the headlamps.

Adjustment value for mechanical aimer

	Mechanical aimer level
Horizontal side	-4 to 4
Vertical side	-4 to 4

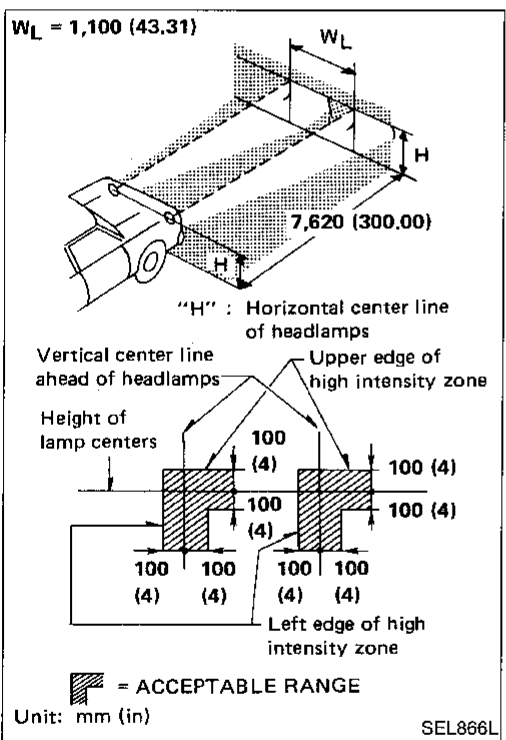
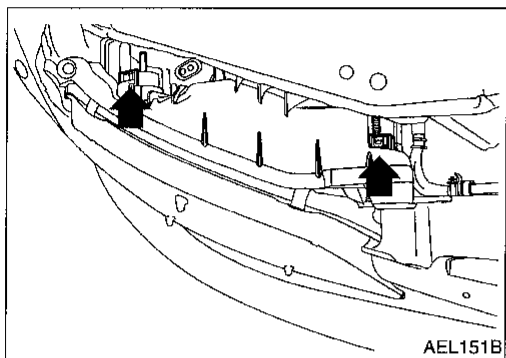
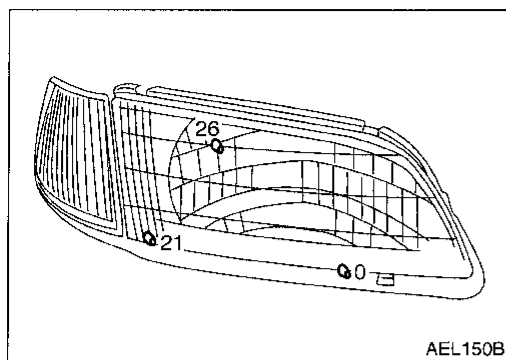

LOW BEAM

1. Turn headlamp low beam on.
 2. Use a #2 cross-recessed screwdriver to adjust the aim of the lamp.
- Cover the opposite lamp and ensure fog lamps, if equipped, are turned off.

If the vehicle front body has been repaired and/or the headlamp assembly has been replaced, check aiming. Use the aiming chart shown in the figure.

- Upper edge and left edge of high intensity zone should be within the range shown at left. Adjust headlamps accordingly.
- Dotted lines in illustration show center of headlamp.

“H”: Horizontal center line of headlamps

“ W_L ”: Distance between each headlamp center

GI

MA

EM

LG

EC

FE

CL

MT

AT

FA

RA

BR

ST

RS

BT

HA

EL

IDX

System Description (For Canada)

The headlamp system for Canada vehicles contains a daytime light control unit that activates the high beam headlamps at approximately half illumination whenever the engine is running. If the parking brake is applied before the engine is started the daytime lights will not be illuminated. The daytime lights will illuminate once the parking brake is released. Thereafter, the daytime lights will continue to operate when the parking brake is applied. If the daytime light control unit receives a ground signal from the generator the daytime lights will not be illuminated. The daytime lights will illuminate once a battery positive voltage signal is sent to the daytime light control unit from the generator.

Power is supplied at all times:

- through 15A fuse (No. 32, located in the fuse and fusible link box)
- to daytime light control unit terminal ③ and
- to lighting switch terminal ⑧.

Power is also supplied at all times:

- through 15A fuse (No. 33, located in the fuse and fusible link box)
- to daytime light control unit terminal ② and
- to lighting switch terminal ⑤.

With the ignition switch in the ON or START position, power is supplied:

- through 10A fuse [No. 8, located in the fuse block (J/B)]
- to daytime light control unit terminal ⑫.

With the ignition switch in the START position, power is supplied:

- through 10A fuse [No. 26, located in the fuse block (J/B)]
- to daytime light control unit terminal ①.

Ground is supplied to daytime light control unit terminal ⑨ through body grounds E10 and E34.

HEADLAMP OPERATION

Low beam operation

When the lighting switch is turned to headlamp “ON” (2ND) position, “LOW BEAM” (B), power is supplied:

- from lighting switch terminal ⑦
- to RH headlamp terminal L9
- to daytime light control unit terminal ④.

Ground is supplied to RH headlamp terminal E through body grounds E10 and E34.

Also, when the lighting switch is turned to headlamp “ON” (2ND) position, “LOW BEAM” (B), power is supplied:

- from lighting switch terminal ⑩
- to LH headlamp terminal L9.

Ground is supplied:

- to LH headlamp terminal E
- from daytime light control unit terminal ⑦
- through daytime light control unit terminal ⑨
- through body grounds E10 and E34.

With power and ground supplied, the low beam headlamps illuminate.

High beam operation/flash-to-pass operation

When the lighting switch is turned to headlamp “ON” (2ND) position, “HIGH BEAM” (A) or “FLASH TO PASS” (C) position, power is supplied:

- from lighting switch terminal ⑥
- to terminal Hi of RH headlamp.

When the lighting switch is turned to headlamp “ON” (2ND) position, “HIGH BEAM” (A) or “FLASH TO PASS” (C) position, power is supplied:

- from lighting switch terminal ⑨
- to daytime light control terminal ⑤
- to combination meter terminal ⑪ for the high beam indicator
- through daytime light control terminal ⑥
- to terminal Hi of LH headlamp.

Ground is supplied in the same manner as low beam operation.

Ground is supplied to terminal ⑩ of the combination meter through body grounds M2 and M61.

With power and ground supplied, the high beam headlamps and HI BEAM indicator illuminate.

HEADLAMP — Daytime Light System —

System Description (For Canada) (Cont'd)

DAYTIME LIGHT OPERATION

With the engine running, the lighting switch in the "OFF" or parking lamp (1ST) position and parking brake released, power is supplied:

- to daytime light control unit terminal ③
- through daytime light control unit terminal ⑥
- to terminal ④ of LH headlamp
- through terminal ⑤ of LH headlamp
- to daytime light control unit terminal ⑦
- through daytime light control unit terminal ⑧
- to terminal ④ of RH headlamp.

Ground is supplied to terminal ⑤ of RH headlamp through body grounds ⑩ and ⑩. Because the high beam headlamps are now wired in series, they operate at half illumination.

Operation (For Canada)

After starting the engine with the lighting switch in the "OFF" or parking lamp (1ST) position, the headlamp high beam automatically turns on. Lighting switch operations other than the above are the same as conventional light systems.

Engine		With engine stopped									With engine running								
		OFF			1ST			2ND			OFF			1ST			2ND		
Lighting switch		A	B	C	A	B	C	A	B	C	A	B	C	A	B	C	A	B	C
Headlamp	High beam	X	X	○	X	X	○	○	X	○	△*	△*	○	△*	△*	○	○	X	○
	Low beam	X	X	X	X	X	X	X	○	X	X	X	X	X	X	X	X	○	X
Parking and tail lamp		X	X	X	○	○	○	○	○	○	X	X	X	○	○	○	○	○	○
License and instrument illumination lamp		X	X	X	○	○	○	○	○	○	X	X	X	○	○	○	○	○	○

A : "HIGH BEAM" position

B : "LOW BEAM" position

C : "FLASH TO PASS" position

○ : Lamp "ON"

X : Lamp "OFF"

△ : Lamp on at half brightness.

□ : Added functions

*: When starting the engine with the parking brake released, the daytime light will come ON.

When starting the engine with the parking brake pulled, the daytime light won't come ON.

HEADLAMP — Daytime Light System —

Wiring Diagram (For Canada) — DTRL —

EL-DTRL-01

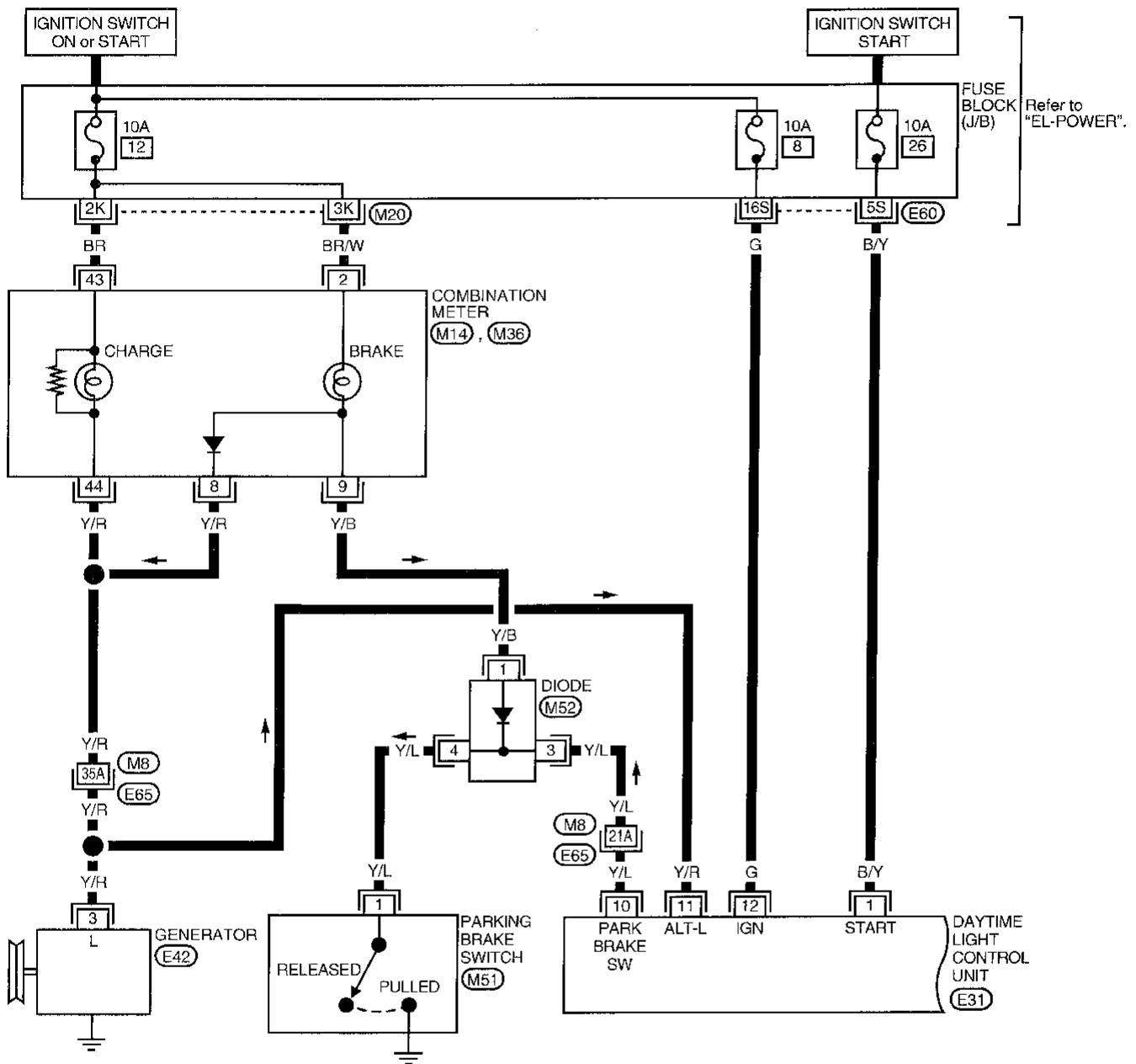

GI
MA
EM
LC
EC
FE
CL
MT
AT
FA
RA
BR
ST
RS
BT

Refer to last page (Foldout page).
(M8), (E65)

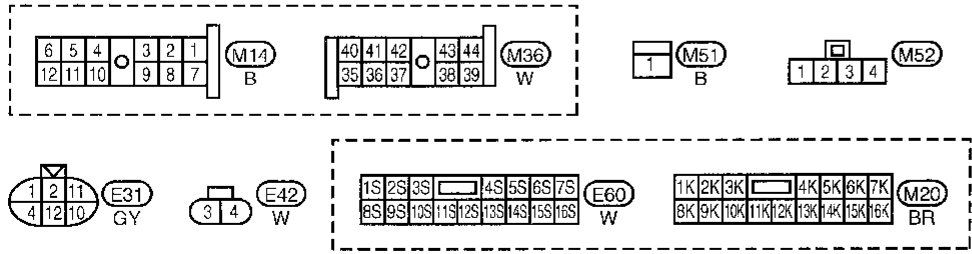

HA
EL
IDX

HEADLAMP — Daytime Light System —

Wiring Diagram (For Canada) — DTRL — (Cont'd)

EL-DTRL-02

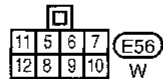
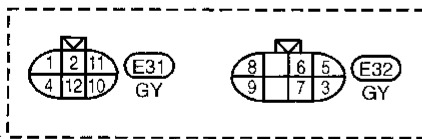
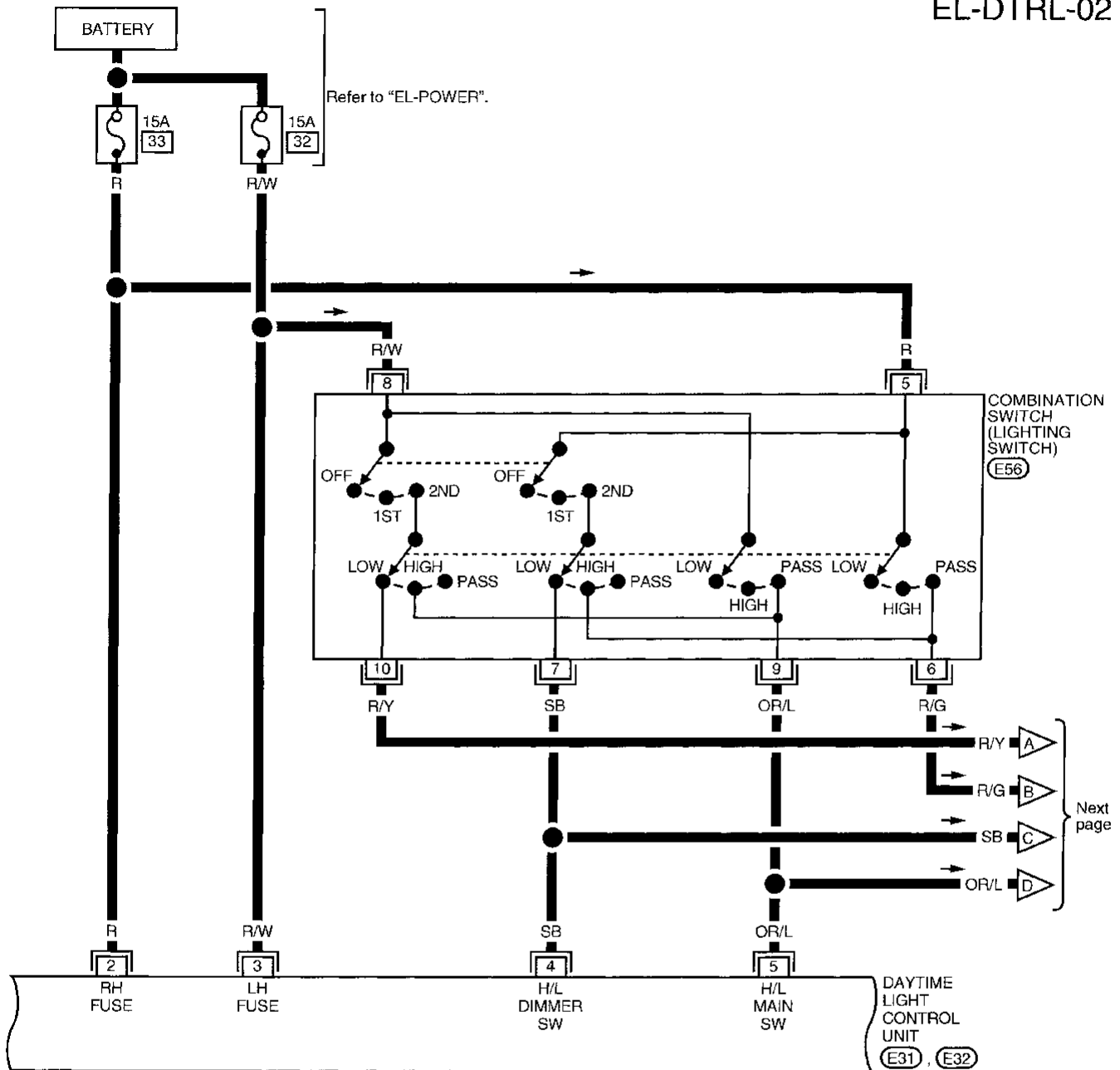

HEADLAMP — Daytime Light System —

Wiring Diagram (For Canada) — DTRL — (Cont'd)

: With theft warning system

EL-DTRL-03

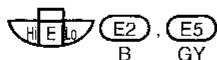
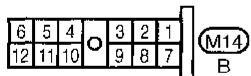
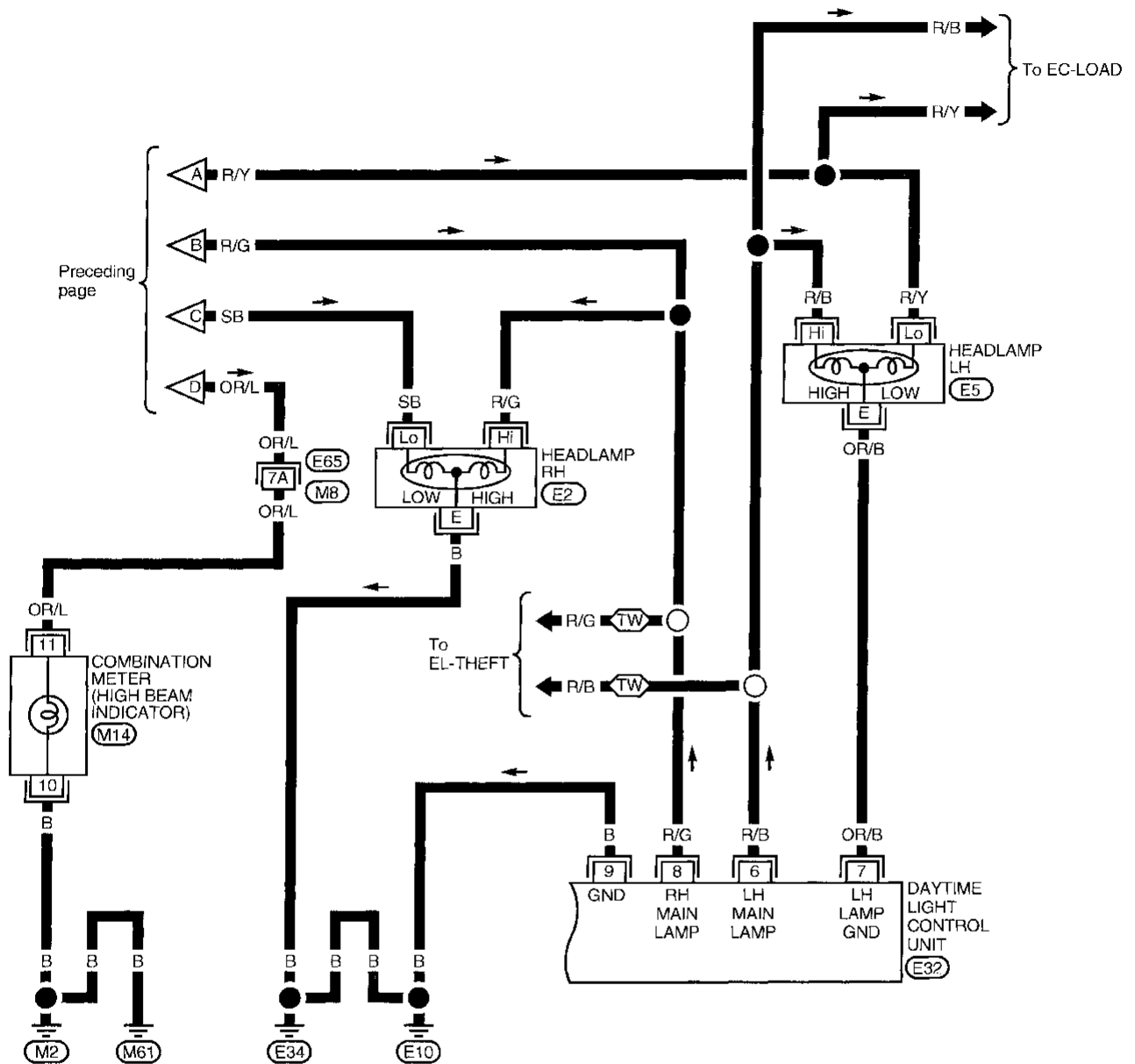









Refer to last page (Foldout page).

GI
MA
EM
LC
EC
FE
CL
MT
AT
FA
RA
BR
ST
RS
BT
HA
EL
IDX

HEADLAMP — Daytime Light System —





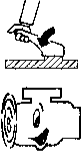
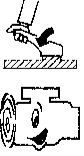

Trouble Diagnoses (For Canada)

DAYTIME LIGHT CONTROL UNIT INSPECTION TABLE

Terminal No.	Item	Condition	Voltage (Approximate values)
1	Start signal	 When turning ignition switch to "ST"	Battery voltage
		 When turning ignition switch to "ON" from "ST"	Less than 1V
		 When turning ignition switch to "OFF"	Less than 1V
2	Power source	 When turning ignition switch to "ON"	Battery voltage
		 When turning ignition switch to "OFF"	Battery voltage
3	Power source	 When turning ignition switch to "ON"	Battery voltage
		 When turning ignition switch to "OFF"	Battery voltage
4	Lighting switch (Lo beam)	When turning lighting switch to headlamp "ON" (2ND) position, "LOW BEAM"	Battery voltage
5	Lighting switch (Hi beam)	When turning lighting switch to "HI BEAM"	Battery voltage
		When turning lighting switch to "FLASH TO PASS"	Battery voltage
6	LH hi beam	When turning lighting switch to "HI BEAM"	Battery voltage
		 When releasing parking brake with engine running and turning lighting switch to "OFF" (daytime light operation) CAUTION: Block wheels and ensure selector lever is in N or P position.	Battery voltage
7	LH headlamp control (ground)	When lighting switch is turned to headlamp "ON" (2ND) position, "LOW BEAM"	Less than 1V
		 When releasing parking brake with engine running and turning lighting switch to "OFF" (daytime light operation) CAUTION: Block wheels and ensure selector lever is in N or P position.	Approx. half battery voltage
8	RH hi beam	When turning lighting switch to "HI BEAM"	Battery voltage
		 When releasing parking brake with engine running and turning lighting switch to "OFF" (daytime light operation) CAUTION: Block wheels and ensure selector lever is in N or P position.	Approx. half battery voltage
9	Ground	—	—

HEADLAMP — Daytime Light System —

Trouble Diagnoses (For Canada) (Cont'd)

Terminal No.	Item	Condition		Voltage (Approximate values)	
10	Parking brake switch		When parking brake is released	Battery voltage	
			When parking brake is set	Less than 1.5V	
11	Generator		When turning ignition switch to "ON"	Less than 4.6V	
				When engine is running	Battery voltage
					When turning ignition switch to "OFF"
12	Power source		When turning ignition switch to "ON"	Battery voltage	
			When turning ignition switch to "ST"	Battery voltage	
			When turning ignition switch to "OFF"	Less than 1V	

Bulb Replacement

Refer to "HEADLAMP" (EL-40).

Aiming Adjustment

Refer to "HEADLAMP" (EL-40).

GI

MA

EM

LC

EC

FE

CL

MT

AT

FA

RA

BR

ST

RS

BT

HA

EL

IDX

PARKING, LICENSE AND TAIL LAMPS

Wiring Diagram — TAIL/L —

EL-TAIL/L-01

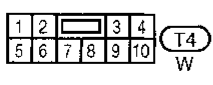
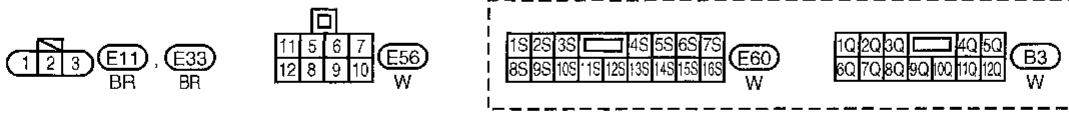
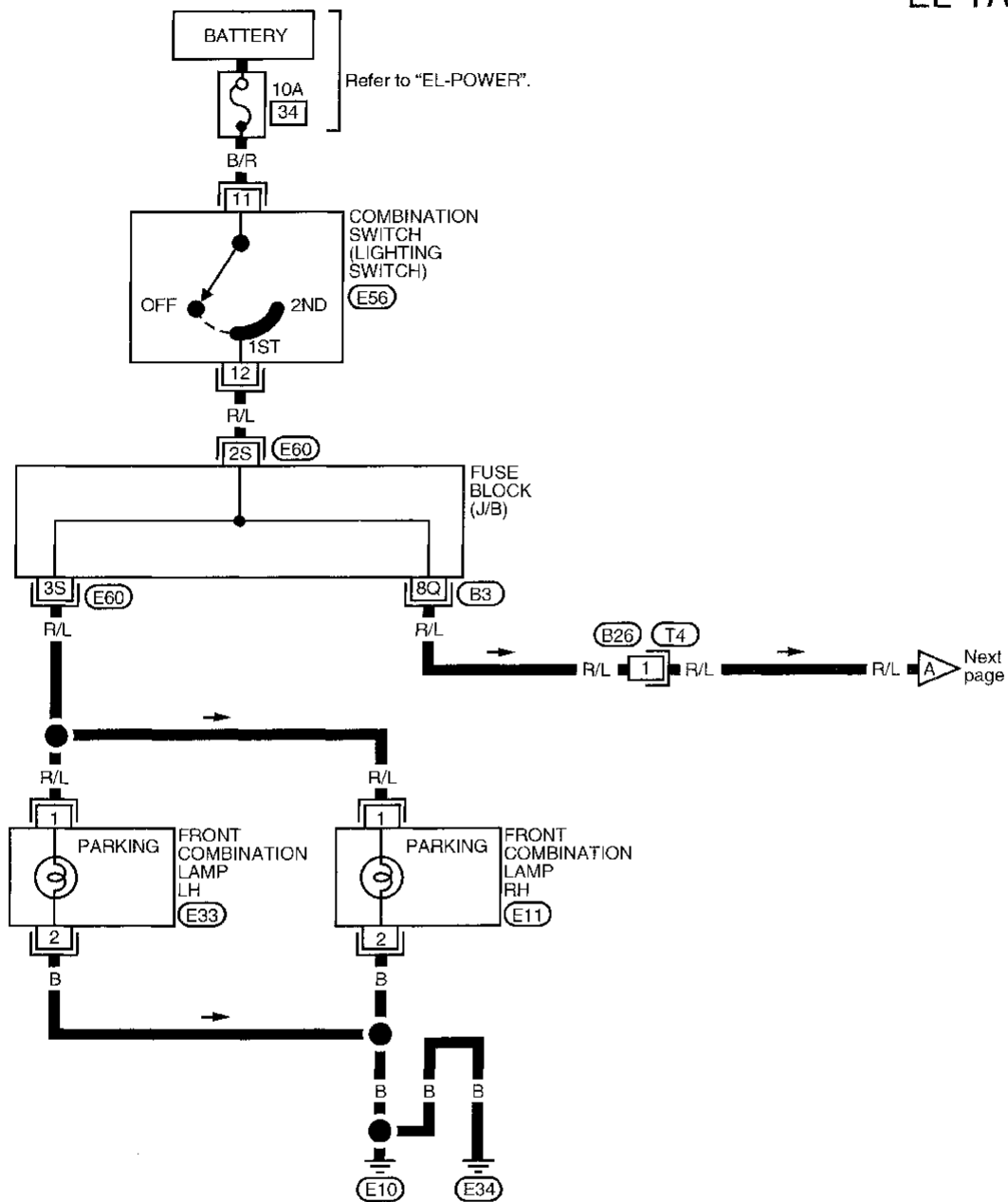

PARKING, LICENSE AND TAIL LAMPS

Wiring Diagram — TAIL/L — (Cont'd)

EL-TAIL/L-02

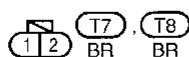
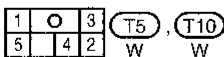
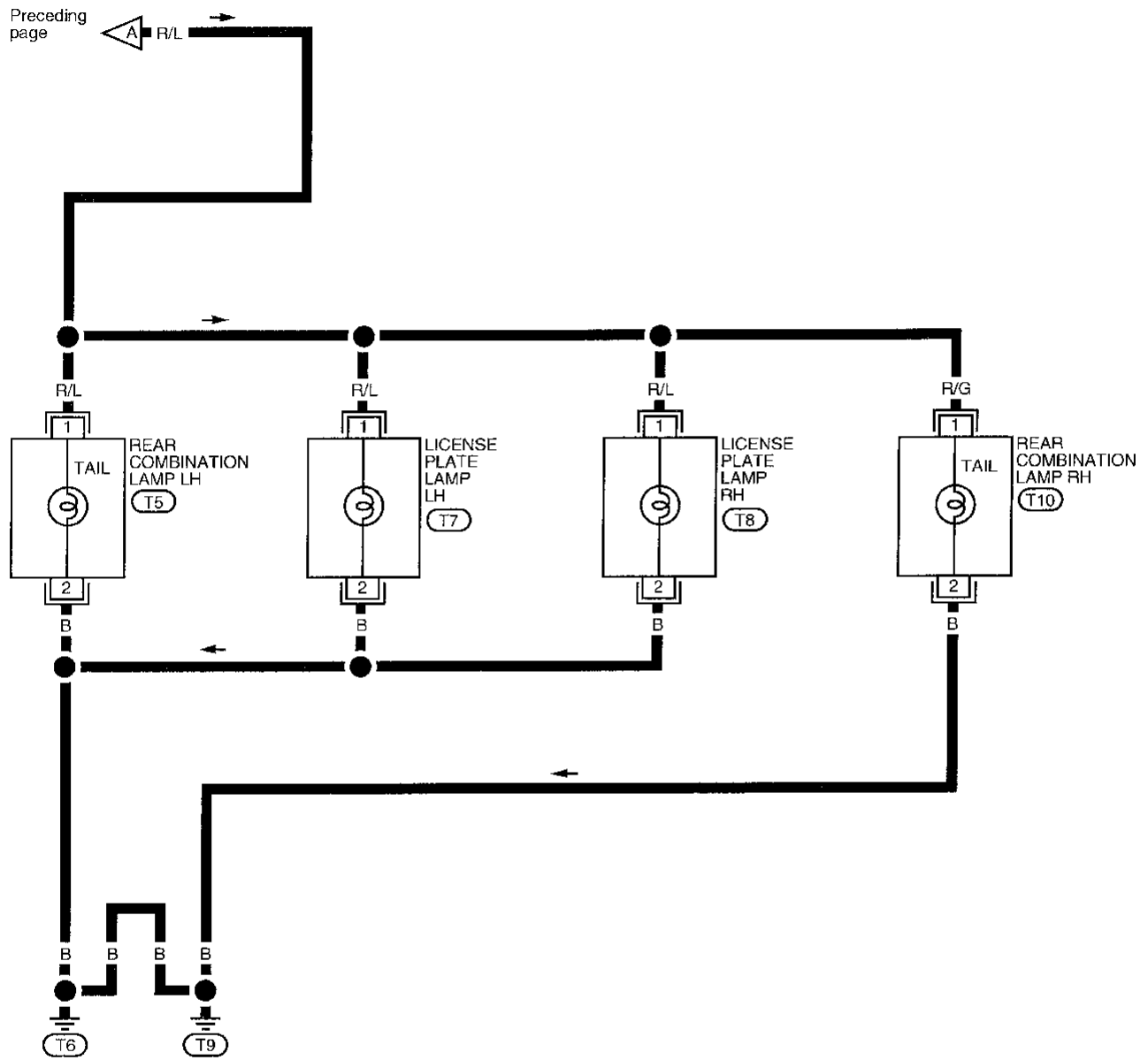

GI
MA
EM
LC
EC
FE
CL
MT
AT
FA
RA
BR
ST
RS
BT
HA
EL
IDX

STOP LAMP

Wiring Diagram — STOP/L —

EL-STOP/L-01

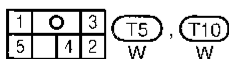
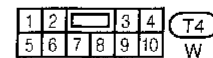
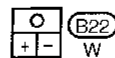
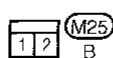
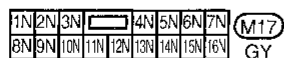
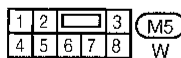
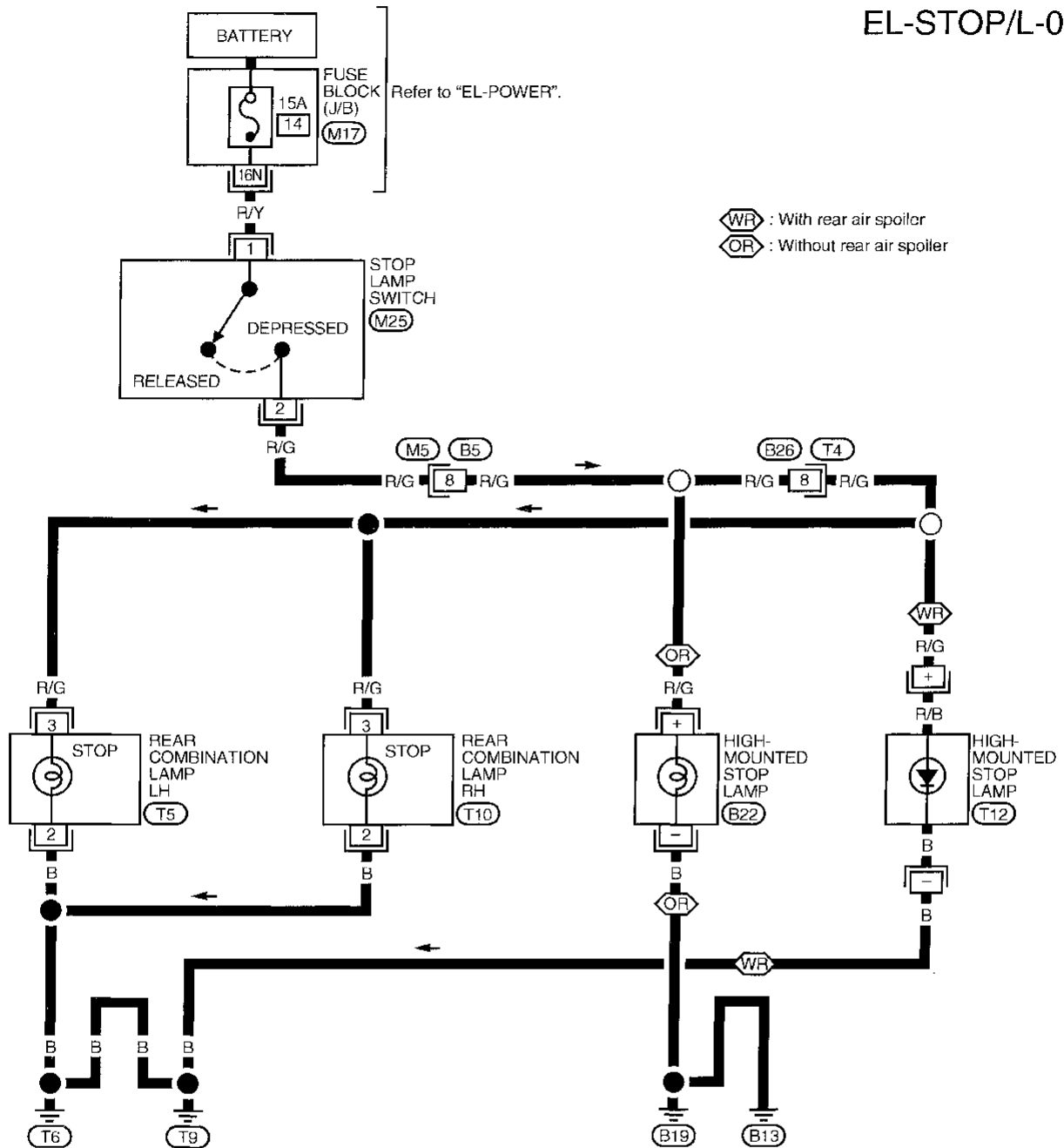

BACK-UP LAMP

Wiring Diagram — BACK/L —

EL-BACK/L-01

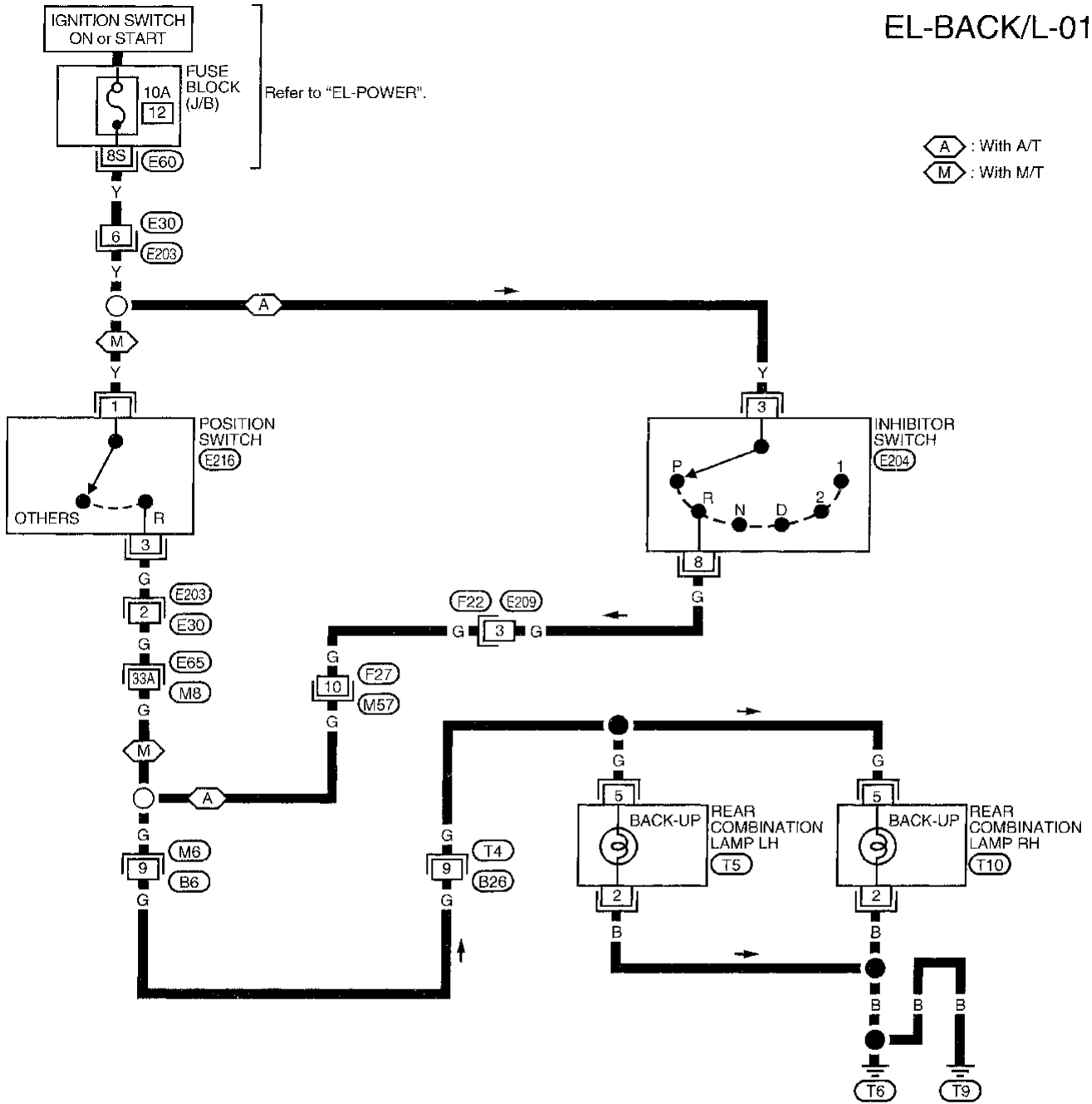

⬡ : With A/T
⬢ : With M/T

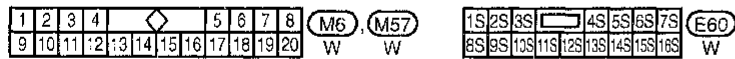

Refer to last page (Foldout page).

⬢ . ⬢

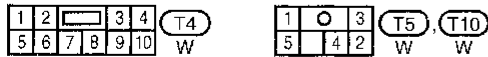
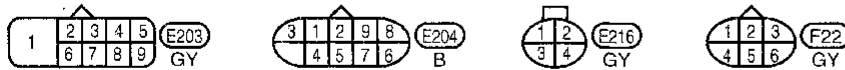

GI

WA

EM

LC

EC

FE

CL

MT

AT

FA

RA

BR

ST

RS

BT

HA

EL

IDX

FRONT FOG LAMP

System Description

Power is supplied at all times to front fog lamp relay terminal ③ through:

- 15A fuse (No. 43), located in the fuse and fusible link box).

With the lighting switch in headlamp "ON" (2ND) position, "LOW BEAM" (B), power is supplied:

- through 15A fuse (No. 33), located in the fuse and fusible link box)
- to lighting switch terminal ⑤
- through terminal ⑦ of the lighting switch
- to front fog lamp relay terminal ①.

Fog lamp operation

The fog lamp switch is built into the combination switch. The lighting switch must be in headlamp "ON" (2ND) position, "LOW BEAM" (B) for fog lamp operation.

With the front fog lamp switch in the ON position:

- ground is supplied to front fog lamp relay terminal ② through the front fog lamp switch and body grounds E10 and E34 .

The fog lamp relay is energized and power is supplied:

- from front fog lamp relay terminal ⑤
- to terminal ① of each front fog lamp.

Ground is supplied to terminal ② of each front fog lamp through body grounds E10 and E34 .

With power and ground supplied, the front fog lamps illuminate.

FRONT FOG LAMP

Wiring Diagram — F/FOG —

EL-F/FOG-01

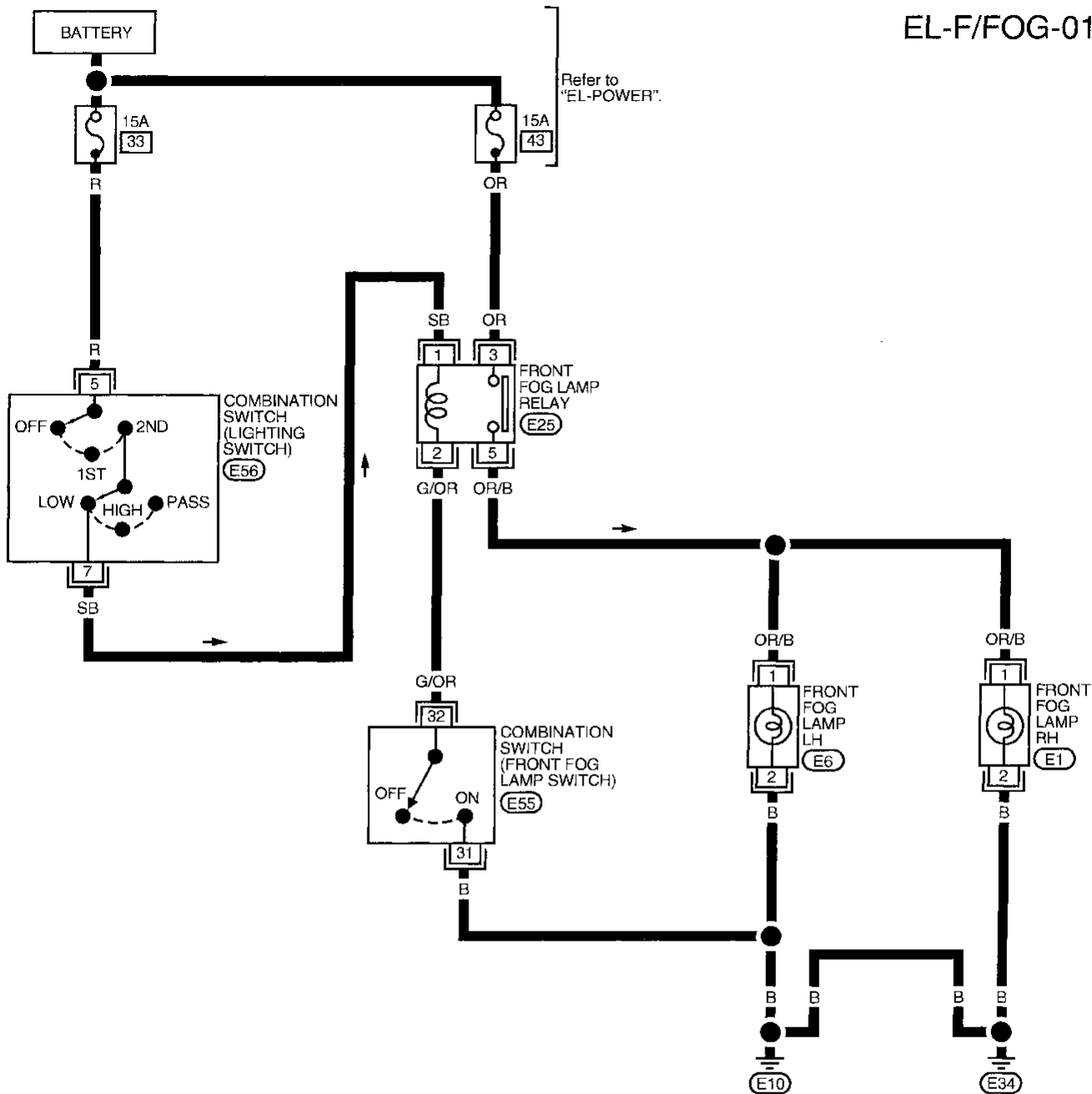

Refer to "EL-POWER".

GI
MA
EM
LC
EC
FE
CL
MT
AT
FA
RA
BR
ST
RS
BT

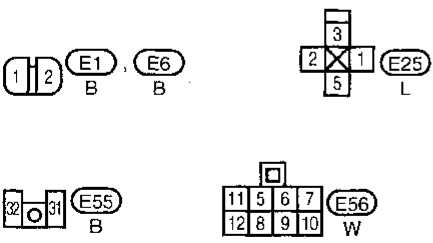

HA
EL
IDX

FRONT FOG LAMP

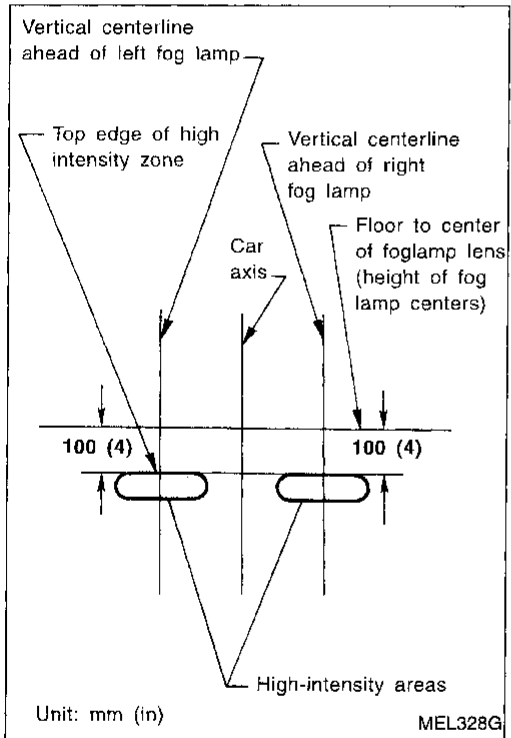
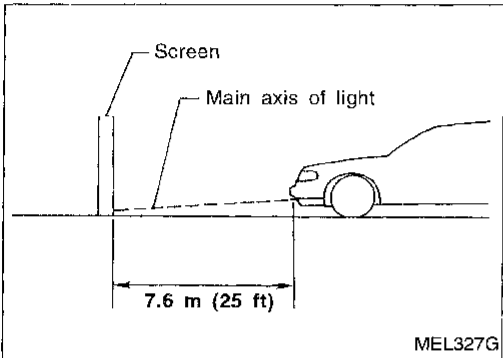
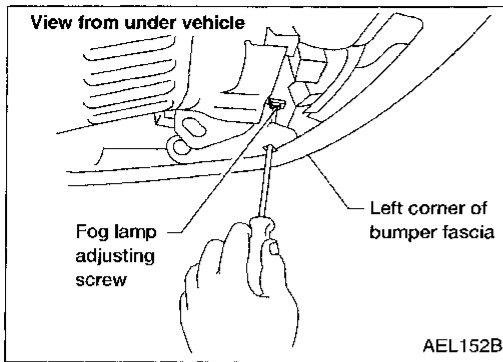

Aiming Adjustment

Before performing aiming adjustment, make sure of the following.

- Keep all tires inflated to correct pressure.
- Place vehicle on level ground.
- Check that vehicle is unloaded (except for full levels of coolant, engine oil and fuel, and spare tire, jack, and tools). Have the driver or equivalent weight placed in driver's seat.

- Set the distance between the screen and the center of the fog lamp lens as shown at left.
- Turn front fog lamps ON.

- Adjust front fog lamps so that the top edge of the high intensity zone is 100 mm (4 in) below the height of the fog lamp centers as shown at left.

- When performing adjustment, if necessary, cover the headlamps and opposite fog lamp.**

System Description

TURN SIGNAL OPERATION

With the hazard switch in the OFF position and the ignition switch in the ON or START position, power is supplied:

- through 10A fuse [No. 11], located in the fuse block (J/B)
- to hazard switch terminal ②
- through terminal ① of the hazard switch
- to combination flasher unit terminal ①
- through terminal ③ of the combination flasher unit
- to turn signal switch terminal ①.

Ground is supplied to combination flasher unit terminal ② through body grounds M2 and M61.

LH turn

When the turn signal switch is moved to the LH position, power is supplied from turn signal switch terminal ③ to:

- front combination lamp LH terminal ③
- combination meter terminal ⑩
- rear combination lamp LH terminal ④.

Ground is supplied to the front combination lamp LH terminal ② through body grounds E10 and E34.

Ground is supplied to the rear combination lamp LH terminal ② through body grounds T6 and T9.

Ground is supplied to combination meter terminal ⑩ through body grounds M2 and M61.

With power and ground supplied, the combination flasher unit controls the flashing of the LH combination lamps.

RH turn

When the turn signal switch is moved to the RH position, power is supplied from turn signal switch terminal ② to:

- front combination lamp RH terminal ③
- combination meter terminal ⑩
- rear combination lamp RH terminal ④.

Ground is supplied to the front combination lamp RH terminal ② through body grounds E10 and E34.

Ground is supplied to the rear combination lamp RH terminal ② through body grounds T6 and T9.

Ground is supplied to combination meter terminal ⑩ through body grounds M2 and M61.

With power and ground supplied, the combination flasher unit controls the flashing of the RH combination lamps.

HAZARD LAMP OPERATION

Power is supplied at all times to hazard switch terminal ③ through:

- 10A fuse [No. 20], located in the fuse block (J/B).

With the hazard switch in the ON position, power is supplied:

- through terminal ① of the hazard switch
- to combination flasher unit terminal ①
- through terminal ③ of the combination flasher unit
- to hazard switch terminal ④.

Ground is supplied to combination flasher unit terminal ② through body grounds M2 and M61.

Power is supplied through terminal ⑤ of the hazard switch to:

- front combination lamp LH terminal ③
- combination meter terminal ⑩
- rear combination lamp LH terminal ④.

Power is supplied through terminal ⑥ of the hazard switch to:

- front combination lamp RH terminal ③
- rear combination lamp RH terminal ④
- combination meter terminal ⑩.

Ground is supplied to terminal ② of each front combination lamp through body grounds E10 and E34.

Ground is supplied to terminal ② of each rear combination lamp through body grounds T6 and T9.

TURN SIGNAL AND HAZARD WARNING LAMPS

System Description (Cont'd)

Ground is supplied to combination meter terminal ⑳ through body grounds M2 and M61 .
With power and ground supplied, the combination flasher unit controls the flashing of the hazard warning lamps.

WITH MULTI-REMOTE CONTROL SYSTEM

Power is supplied at all times:

- through 10A fuse [No. 20, located in the fuse block (J/B)]
- to multi-remote control relay-1 terminals ①, ③ and ⑥.

Ground is supplied to multi-remote control relay-1 terminal ②, when the multi-remote control system is triggered through the smart entrance control unit.

Refer to "MULTI-REMOTE CONTROL SYSTEM" (EL-182).

When multi-remote control relay-1 is energized.

Power is supplied through terminal ⑤ of the multi-remote control relay-1:

- to front combination lamp LH terminal ③
- to combination meter terminal ⑳
- to rear combination lamp LH terminal ④.

Power is supplied through terminal ⑦ of the multi-remote control relay-1:

- to front combination lamp RH terminal ③
- to combination meter terminal ⑳
- to rear combination lamp RH terminal ④.

Ground is supplied to terminal ② of each front combination lamp through body grounds E10 and E34 .

Ground is supplied to terminal ② of each rear combination lamp through body grounds T6 and T9 .

Ground is supplied to combination meter terminal ⑳ through body grounds M2 and M61 .

With power and ground supplied, the smart entrance control unit controls the flashing of the hazard warning lamps.

TURN SIGNAL AND HAZARD WARNING LAMPS

NOTES

GI

MA

EM

LC

EC

FE

CL

MT

AT

FA

RA

BR

ST

RS

BT

HA

EL

IDX

TURN SIGNAL AND HAZARD WARNING LAMPS

Wiring Diagram — TURN —

EL-TURN-01

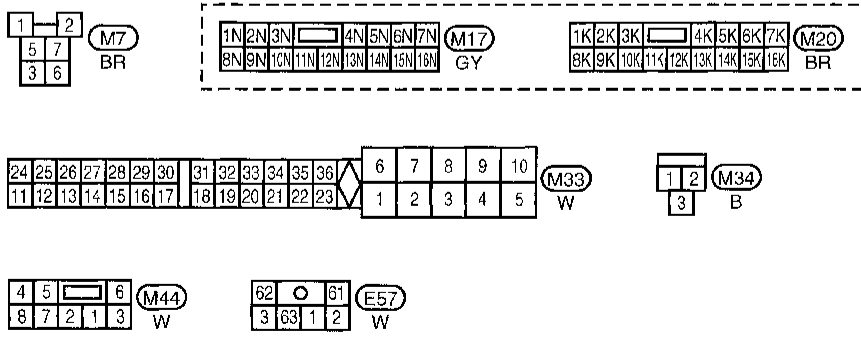
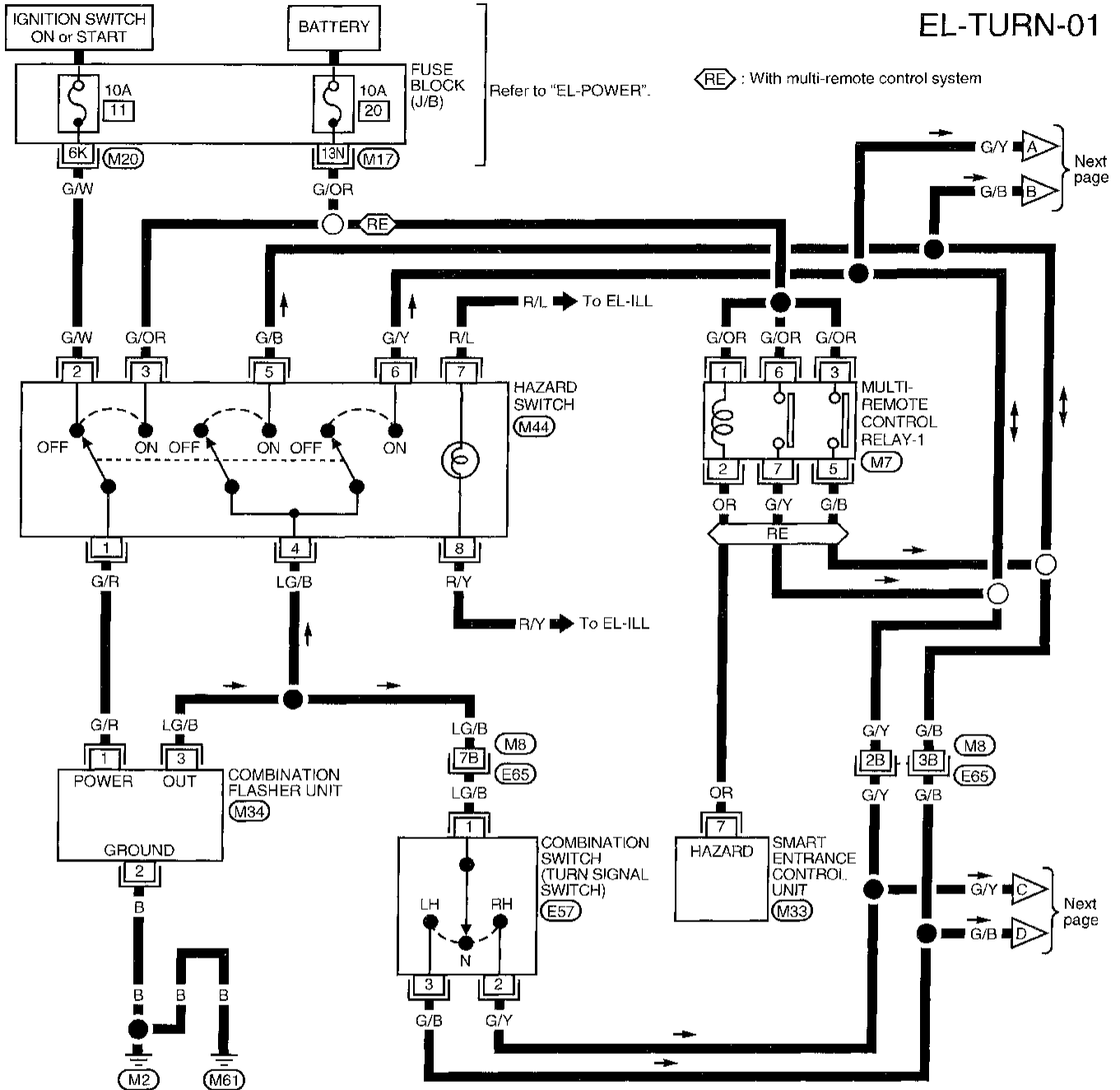

Refer to last page (Foldout page).
 (M8), (E65)

TURN SIGNAL AND HAZARD WARNING LAMPS

Wiring Diagram — TURN — (Cont'd)

EL-TURN-02

GI
 MA
 EM
 LC
 EC
 PE
 CL
 MT
 AT
 FA
 RA
 BR
 ST
 RS
 BT

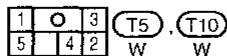
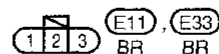
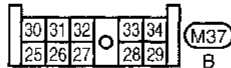
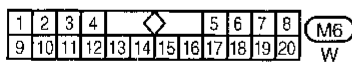
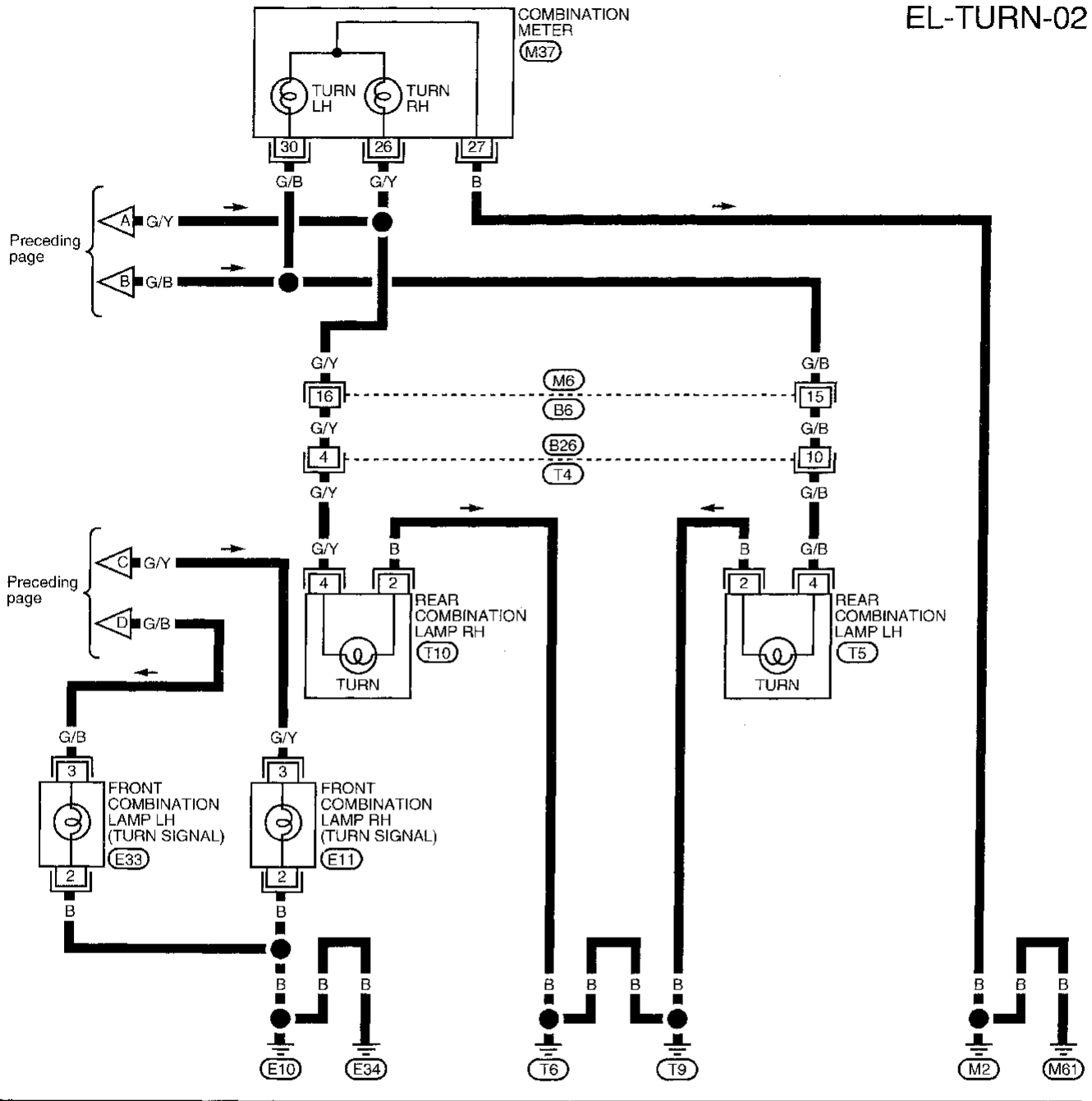

EL

IDX

TURN SIGNAL AND HAZARD WARNING LAMPS

Trouble Diagnoses

Symptom	Possible cause	Repair order
Turn signal and hazard warning lamps do not operate.	<ol style="list-style-type: none"> 1. Hazard switch 2. Combination flasher unit 3. Open in combination flasher unit circuit 	<ol style="list-style-type: none"> 1. Check hazard switch. 2. Refer to combination flasher unit check. 3. Check wiring to combination flasher unit for open circuit.
Turn signal lamps do not operate but hazard warning lamps operate.	<ol style="list-style-type: none"> 1. 10A fuse 2. Hazard switch 3. Turn signal switch 4. Open in turn signal switch circuit 	<ol style="list-style-type: none"> 1. Check 10A fuse [No. 11], located in fuse block (J/B). Turn ignition switch ON and verify battery positive voltage is present at terminal 2 of hazard switch. 2. Check hazard switch. 3. Check turn signal switch. 4. Check LG/B wire between combination flasher unit and turn signal switch for open circuit.
Hazard warning lamps do not operate but turn signal lamps operate.	<ol style="list-style-type: none"> 1. 10A fuse 2. Hazard switch 3. Open in hazard switch circuit 	<ol style="list-style-type: none"> 1. Check 10A fuse [No. 20], located in fuse block (J/B). Verify battery positive voltage is present at terminal 3 of hazard switch. 2. Check hazard switch. 3. Check LG/B wire between combination flasher unit and hazard switch for open circuit.
Front turn signal lamp LH or RH does not operate.	<ol style="list-style-type: none"> 1. Bulb 2. Grounds E10 and E34 	<ol style="list-style-type: none"> 1. Check bulb. 2. Check grounds E10 and E34 .
Rear turn signal lamp LH does not operate.	<ol style="list-style-type: none"> 1. Bulb 2. Grounds T6 and T9 	<ol style="list-style-type: none"> 1. Check bulb. 2. Check grounds T6 and T9 .
Rear turn signal lamp RH does not operate.	<ol style="list-style-type: none"> 1. Bulb 2. Grounds T6 and T9 	<ol style="list-style-type: none"> 1. Check bulb. 2. Check grounds T6 and T9 .
LH and RH turn indicators do not operate.	<ol style="list-style-type: none"> 1. Ground 	<ol style="list-style-type: none"> 1. Check grounds M2 and M61 .
LH or RH turn indicator does not operate.	<ol style="list-style-type: none"> 1. Bulb 	<ol style="list-style-type: none"> 1. Check bulb in combination meter.

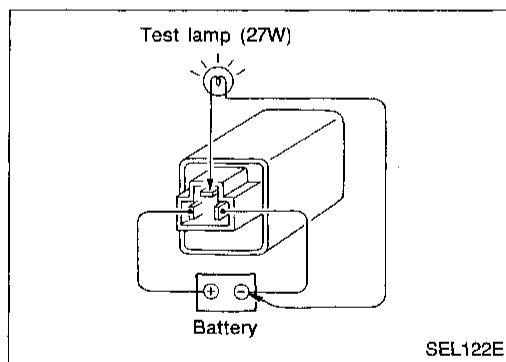

Electrical Components Inspection

COMBINATION FLASHER UNIT CHECK

- Before checking, ensure that bulbs meet specifications.
- Connect a battery and test lamp to the combination flasher unit, as shown. Combination flasher unit is properly functioning if it blinks when power is supplied to the circuit.

ILLUMINATION

System Description

Power is supplied at all times:

- through 10A fuse (No. 34, located in the fuse and fusible link box)
- to lighting switch terminal ⑪.

The lighting switch must be in parking lamp (1ST) or headlamp "ON" (2ND) position for illumination.

The illumination control switch controls the amount of current to the illumination system. As the amount of current increases, the illumination becomes brighter.

The following chart shows the power and ground connector terminals for the components included in the illumination system.

Component	Connector No.	Power terminal	Ground terminal
Illumination control switch	M21	①	⑤
ASCD main switch	M22	⑤	⑥
Combination meter	M36	④①	④①
Hazard switch	M44	⑦	⑧
Rear window defogger switch	M35	⑤	⑥
Glove box lamp	M54	⊕	⊖
Push control unit	M47, M48	⑮	⑮
A/T device indicator	M50	③	④
Radio	M40	⑧	⑦
Main power window and door lock/unlock switch	D7	③	⑧

The ground for all of the components except for the glove box lamp is controlled through terminal ④ of the illumination control switch and body grounds ② and ⑥.

GI

MA

EM

LC

EC

FE

CL

MT

AT

FA

RA

BR

ST

RS

BT

HA

EL

IDX

ILLUMINATION

Wiring Diagram — ILL —

EL-ILL-01

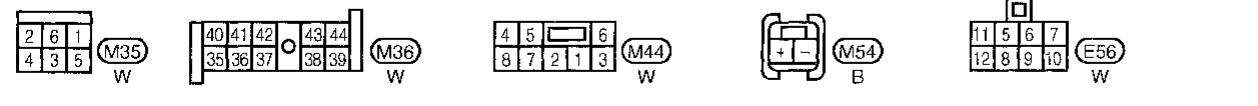
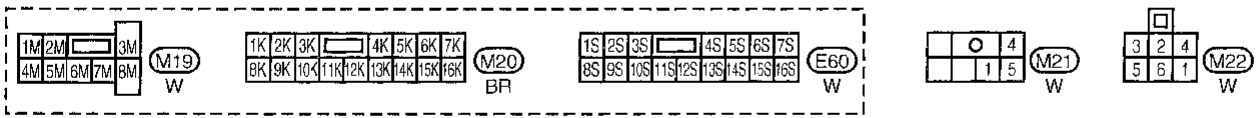
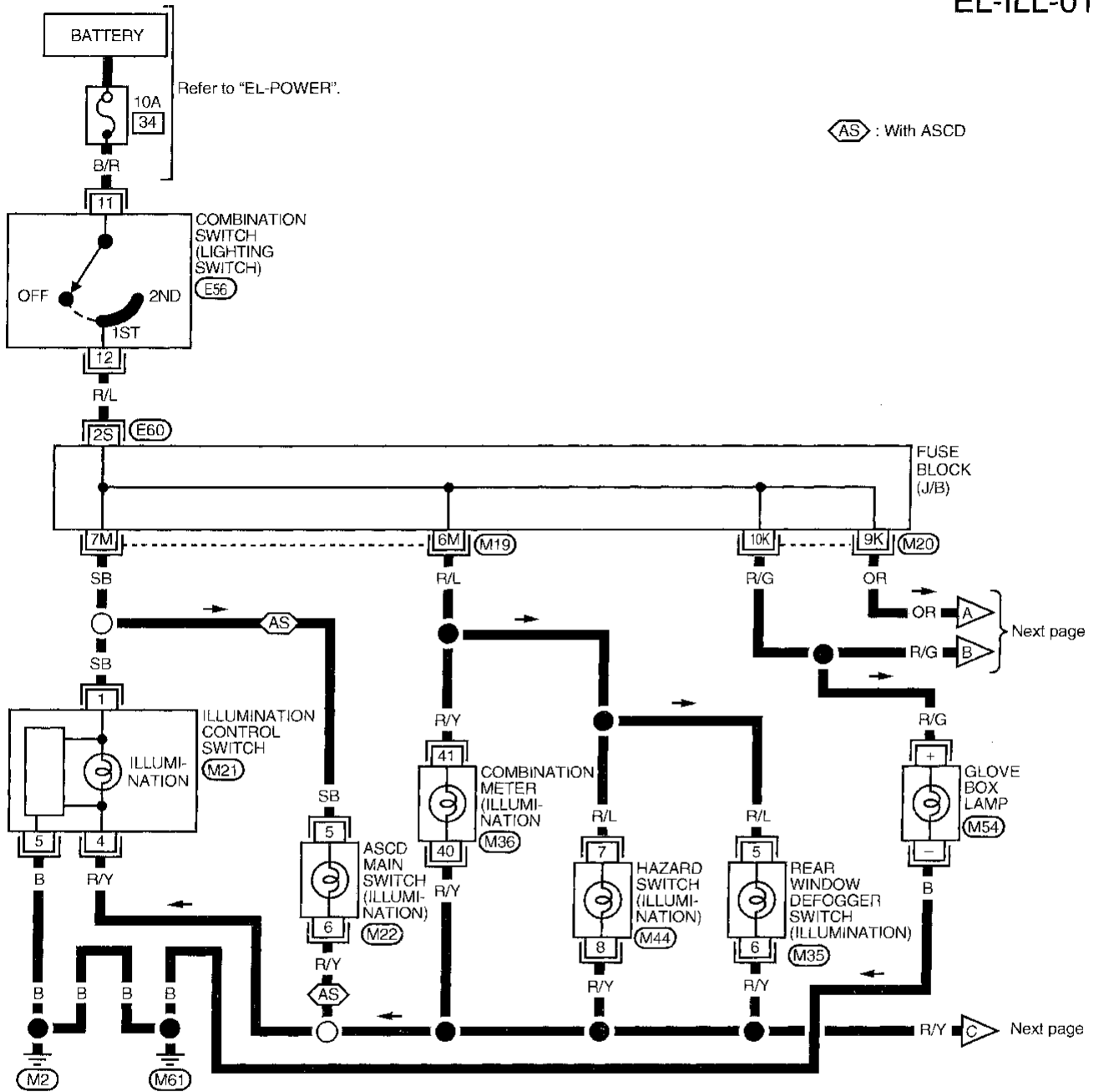

ILLUMINATION

Wiring Diagram — ILL — (Cont'd)

EL-ILL-02 GI

AC : With air conditioner MA
A : With A/T EM

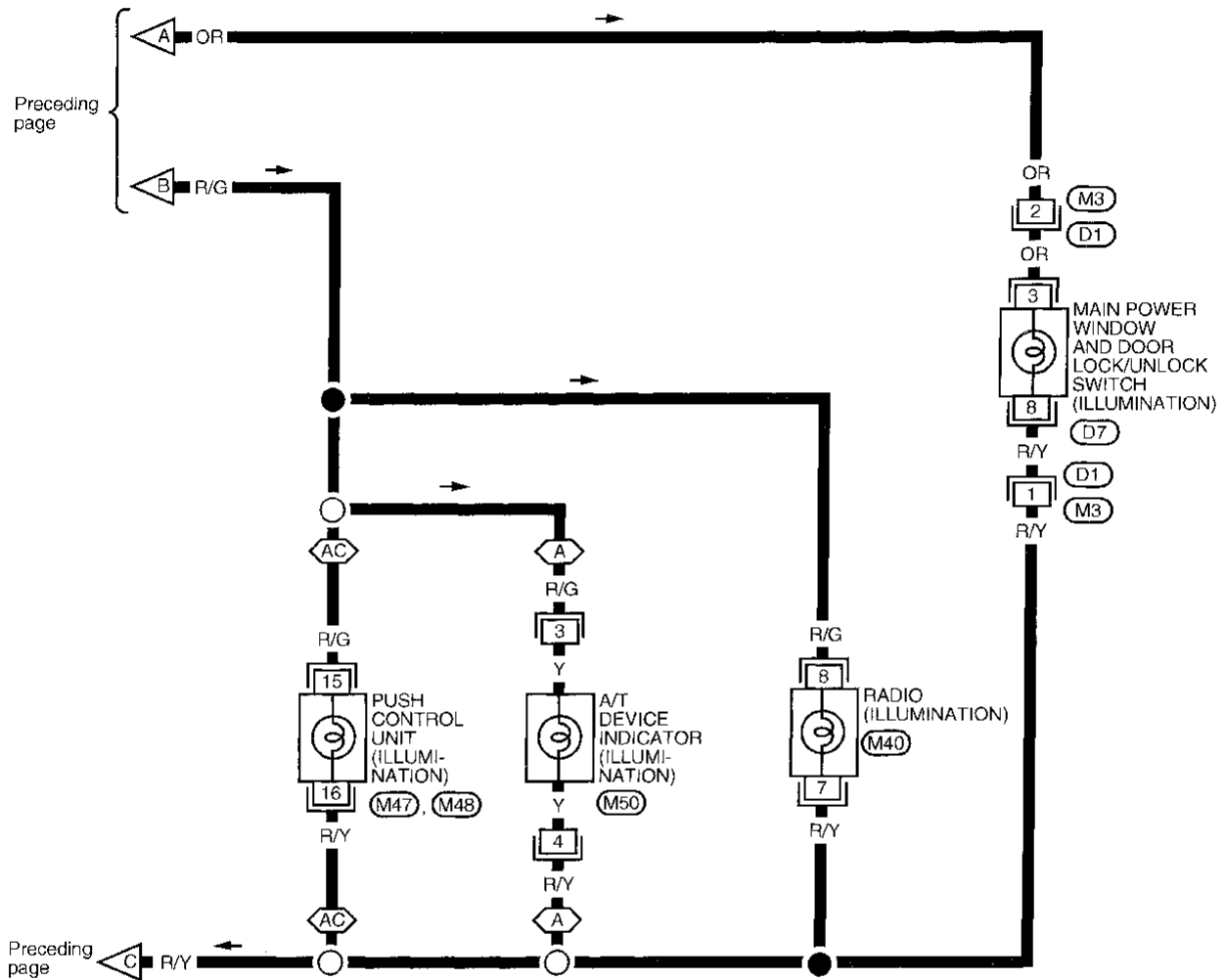

LC
 EC
 FE
 CL
 MT
 AT
 FA
 RA
 BR
 ST
 RS
 BT

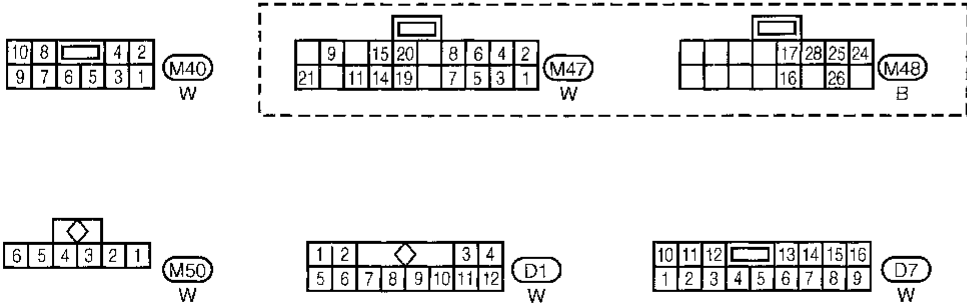

HA
EL
 IDX

INTERIOR ROOM LAMP

Component Parts and Harness Connector Location

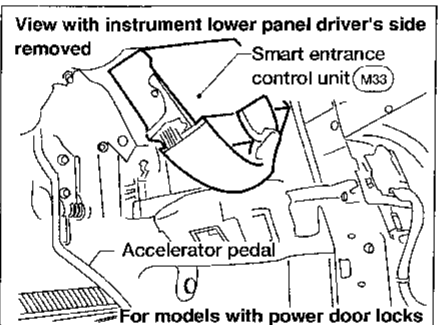
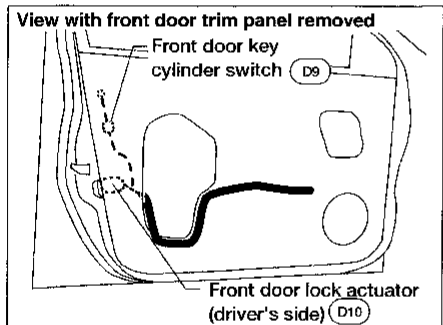
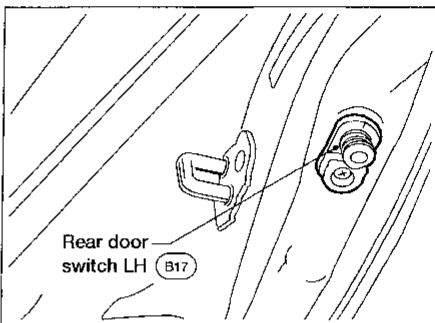
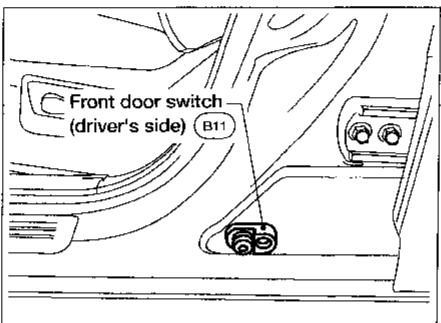
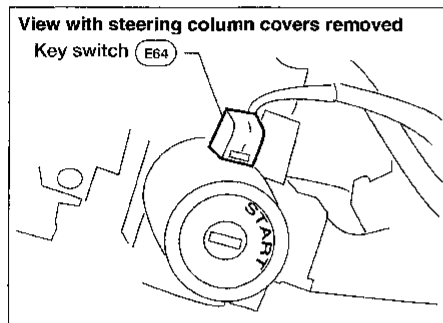
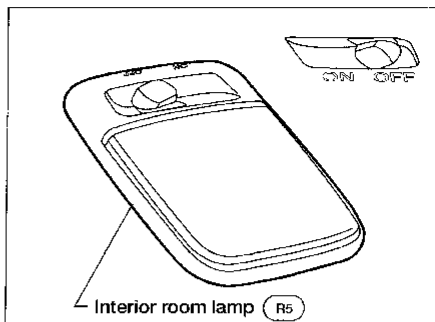
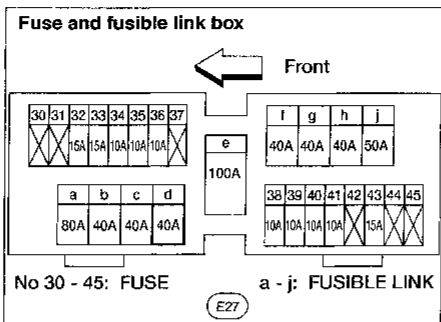
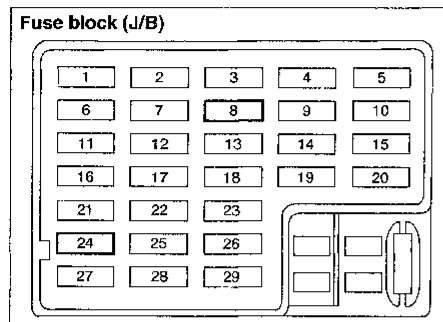

System Description

MODELS WITH POWER DOOR LOCKS

Power supply and ground

Power is supplied at all times:

- through 40A fusible link (Letter **d**, located in the fuse and fusible link box)
- to circuit breaker-1 terminal ①
- through circuit breaker-1 terminal ②
- to smart entrance control unit terminal ①.

Power is supplied at all times:

- through 10A fuse [No. **24**, located in the fuse block (J/B)]
- to key switch terminal ② and
- to room lamp terminal ③

When the key is removed from ignition key cylinder, power is interrupted:

- through terminal key switch ①
- to smart entrance control unit terminal ②4.

With the ignition key switch in the ON or START position, power is supplied:

- through 10A fuse [No. **8**, located in the fuse block (J/B)]
- to smart entrance control unit terminal ①1.

Ground is supplied:

- to smart entrance control unit terminal ⑩
- through body grounds terminal **M2** and **M61**.

When the front LH door is opened, ground is supplied:

- from front door switch LH terminal ①
- to smart entrance control unit terminal ⑮.

When any other door is opened ground is supplied to smart entrance control unit terminal ⑮ or ⑳ in the same manner as the front door switch LH.

When the front door LH is unlocked using remote controller, the smart entrance control unit receives a ground signal:

- through body grounds terminal **M2** and **M61**
- to front door unlock sensor terminal ②
- from front door unlock sensor terminal ④
- to smart entrance control unit terminal ⑫.

When a signal, or combination of signals is received by the smart entrance control unit, ground is supplied:

- through smart entrance control unit terminal ⑨
- to room lamp terminal ④.

With power and ground supplied, the interior room lamp illuminates.

Switch operation

When the room lamp switch is ON, ground is supplied:

- to room lamp
- through case ground of room lamp.

With power and ground supplied, the room lamp turns ON.

Interior room lamp timer operation

When the room lamp switch is in the "DOOR" position, the smart entrance control unit keeps the interior room lamp illuminated for about 30 seconds when:

- unlock signal is supplied from multi-remote controller (Models with multi-remote control system)
- key is removed from ignition key cylinder while driver's door is closed
- driver's door is opened and then closed while ignition switch is not in the ON position.

The timer is canceled, and interior room lamp turns off when:

- driver's door is locked with remote controller, or
- ignition switch is turned ON.

The smart entrance control unit will shut off the room light if left on for 30 minutes.

ON-OFF control

When the driver side door, front passenger door, rear LH or RH door is opened, the room lamp turns on while the room lamp switch is in the "DOOR" position.

GI

MA

EM

LC

EC

FE

CL

MT

AT

FA

RA

BR

ST

RS

BT

HA

EL

IDX

INTERIOR ROOM LAMP

System Description (Cont'd)

When any door is opened and then closed while the ignition switch is not in the ON position, the room lamp timer operates.

MODELS WITHOUT POWER DOOR LOCKS

Power is supplied at all times:

- through 10A fuse [No. 24, located in the fuse block (J/B)]
- to room lamp terminal ⊕.

With the room lamp switch ON, ground is supplied to turn room lamp ON.

When a door switch is opened with the room lamp switch in "DOOR" position, ground is supplied:

- to room lamp switch terminal ⊖
- through front door switch LH terminal ①, rear door switch LH or RH terminal ①.

With power and ground supplied, the room lamp turns ON.

INTERIOR ROOM LAMP

NOTES

GI

MA

EM

LC

EC

FE

CL

MT

AT

FA

RA

BR

ST

RS

BT

HA

EL

IDX

INTERIOR ROOM LAMP

Wiring Diagram — ROOM/L —

MODELS WITH POWER DOOR LOCKS

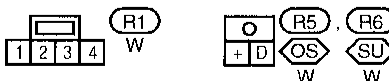
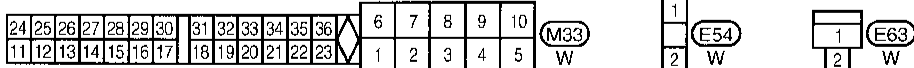
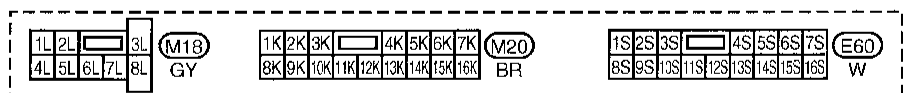
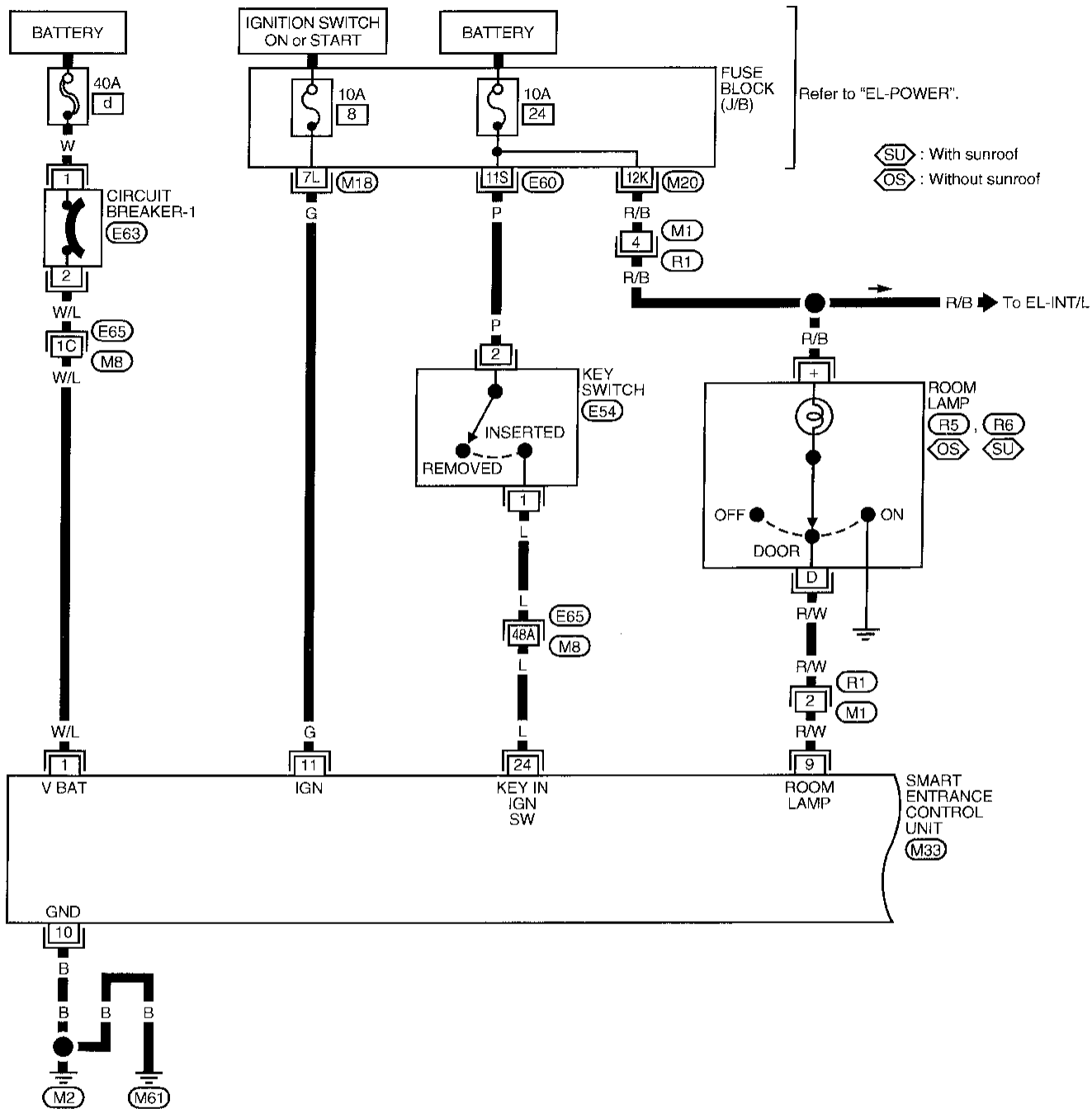

INTERIOR ROOM LAMP

Wiring Diagram — ROOM/L — (Cont'd)

EL-ROOM/L-02

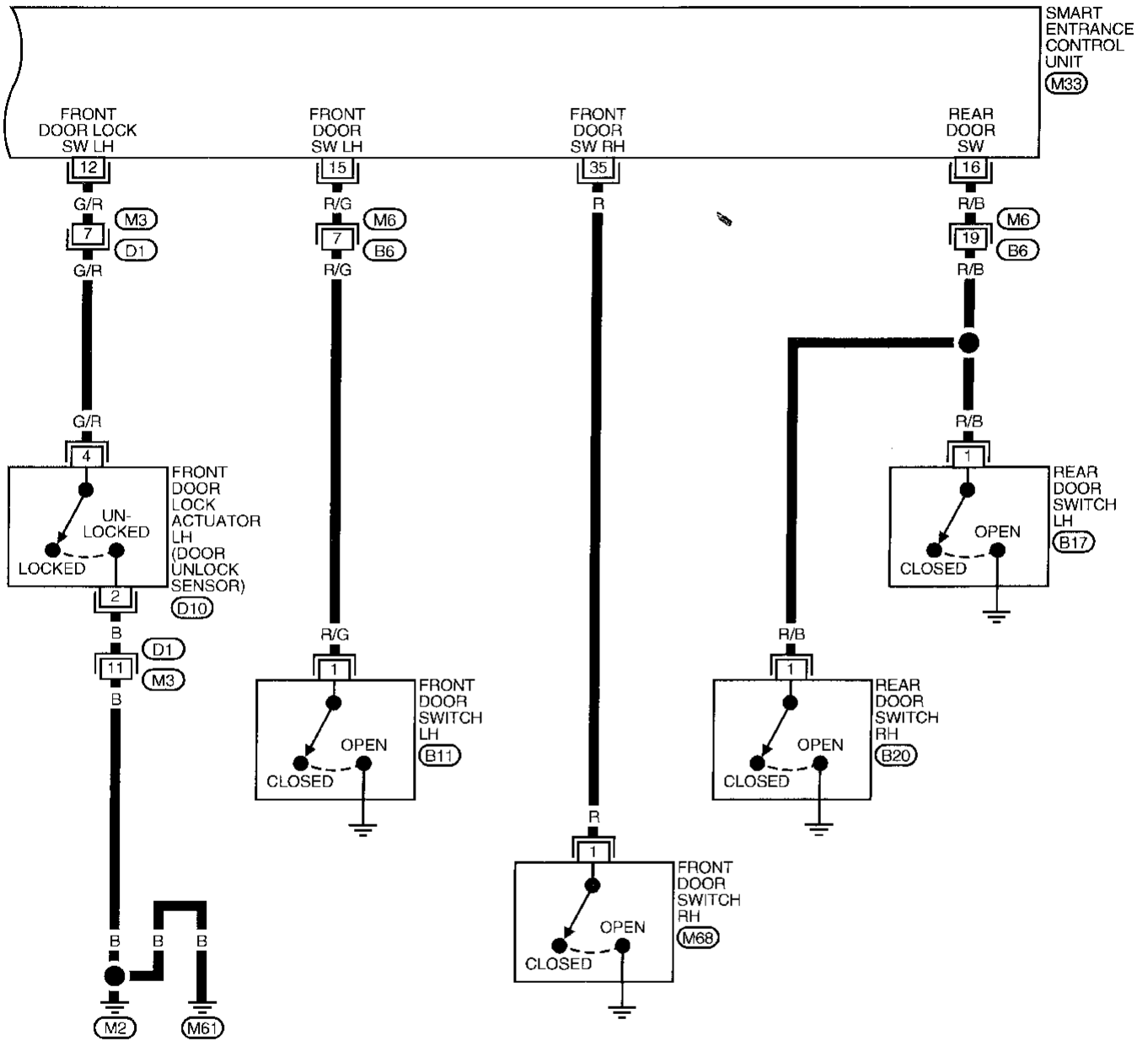

1	2	3	4	◇	5	6	7	8	M6			
9	10	11	12	13	14	15	16	17	18	19	20	W

24	25	26	27	28	29	30	31	32	33	34	35	36	◇	6	7	8	9	10	M33
11	12	13	14	15	16	17	18	19	20	21	22	23	◇	1	2	3	4	5	W

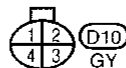
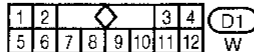
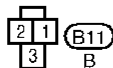
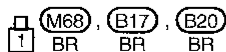

GI
MA
EM
LC
EC
FE
CL
MT
AT
FA
RA
BR
ST
RS
BT
HA
EL
IDX

INTERIOR ROOM LAMP

Wiring Diagram — ROOM/L — (Cont'd)

MODELS WITHOUT POWER DOOR LOCKS

EL-ROOM/L-03

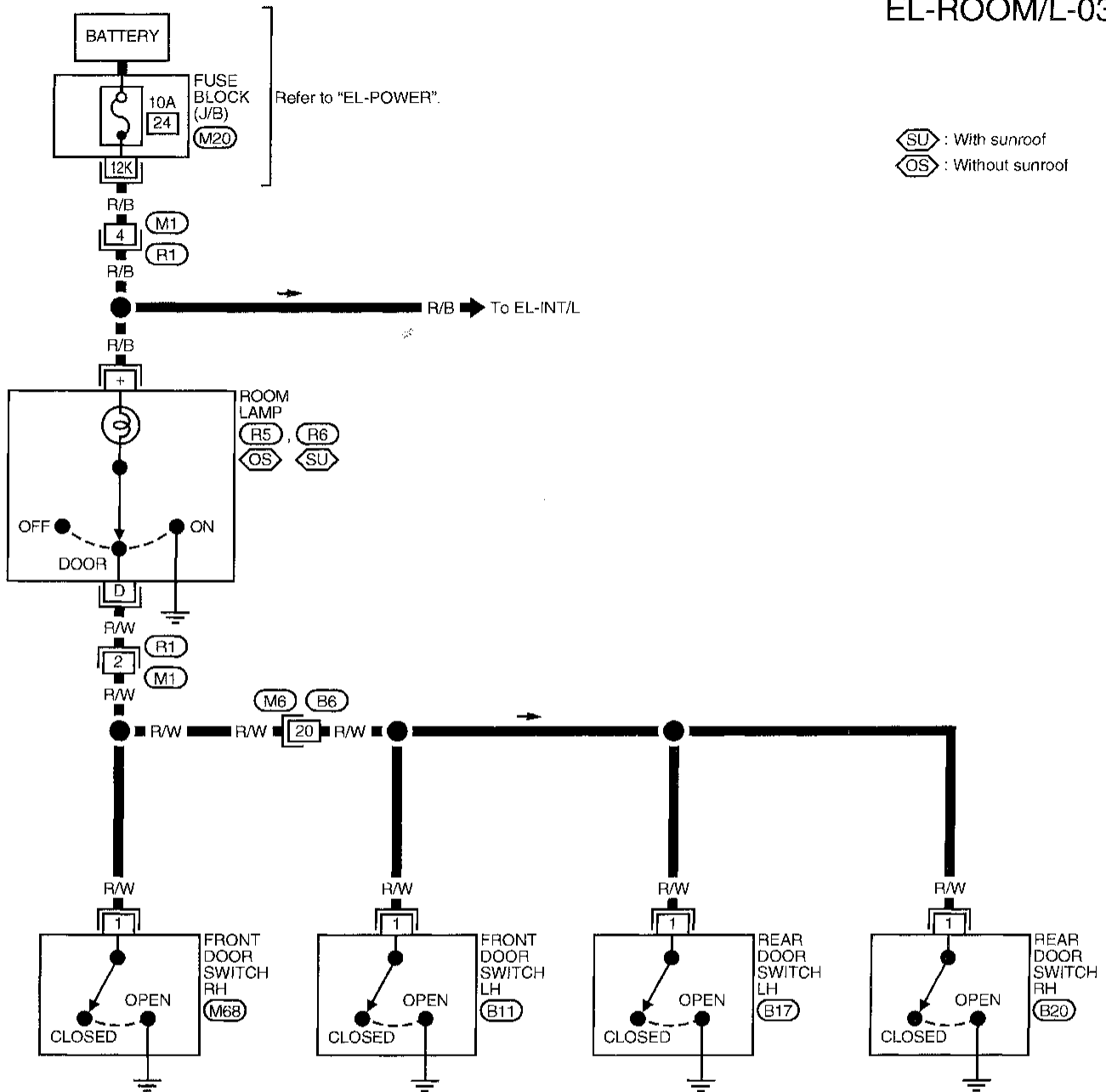

SU : With sunroof
OS : Without sunroof

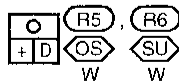
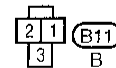
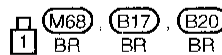
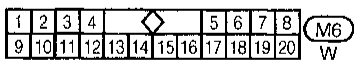

INTERIOR ROOM LAMP

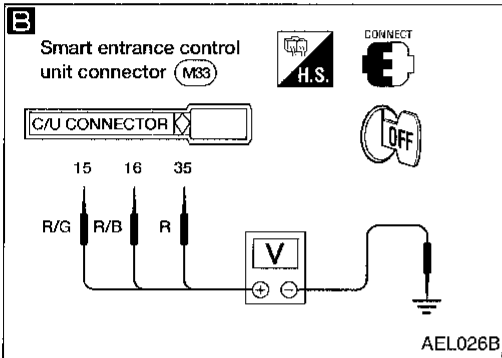
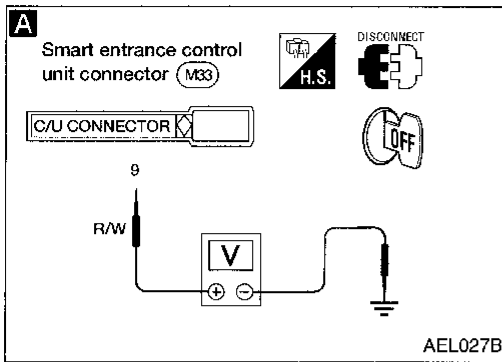

Trouble Diagnoses (For models with power door lock)

DIAGNOSTIC PROCEDURE

SYMPTOM: Room lamp does not turn on when any door is opened, or timer does not operate properly.

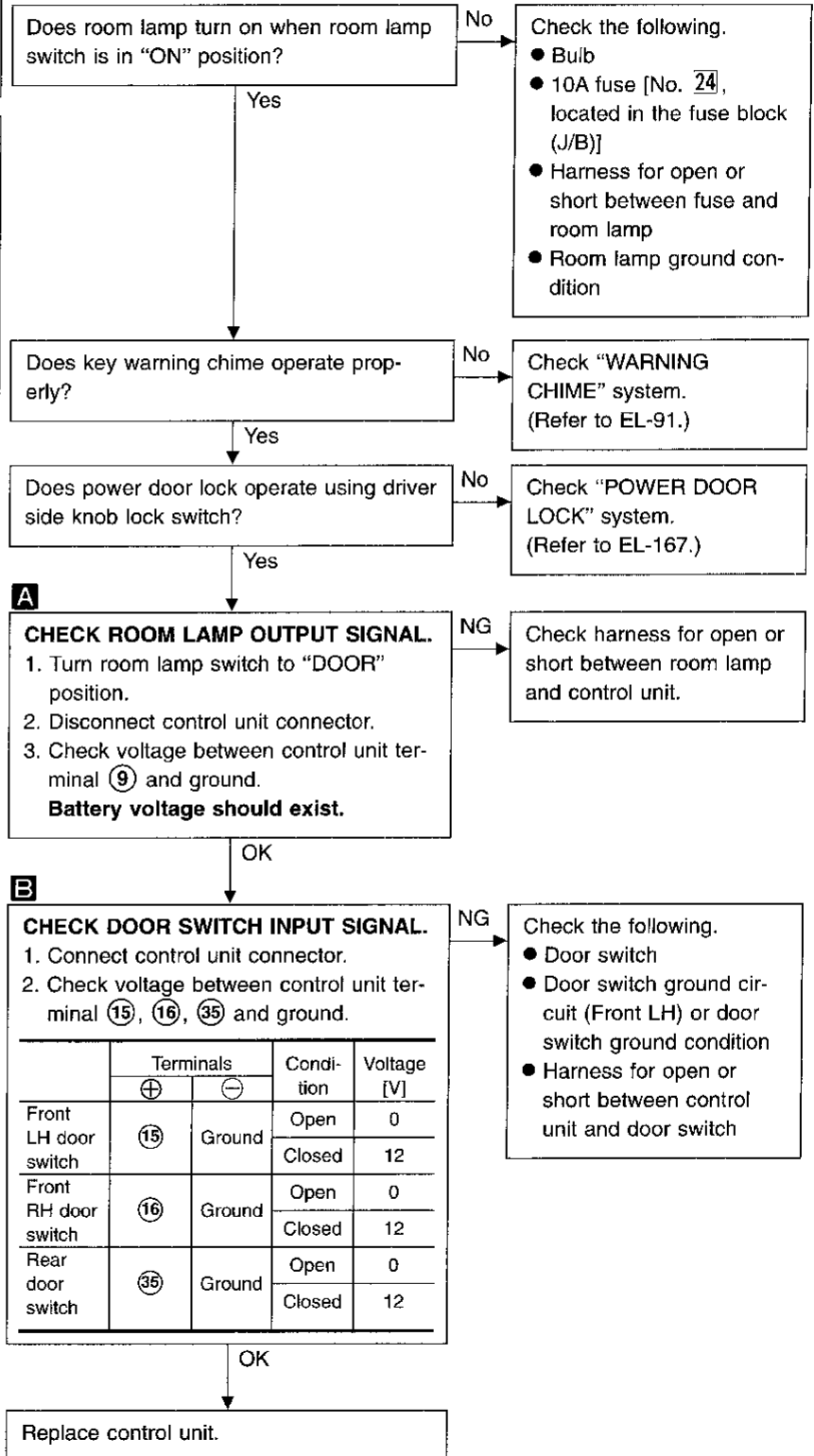

GI

MA

EM

LC

EC

FE

CL

WT

AT

FA

RA

BR

ST

RS

BT

HA

EL

IDX

SPOT, TRUNK ROOM AND VANITY MIRROR LAMPS

Wiring Diagram — INT/L —

EL-INT/L-01

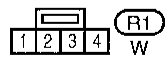
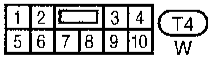
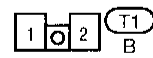
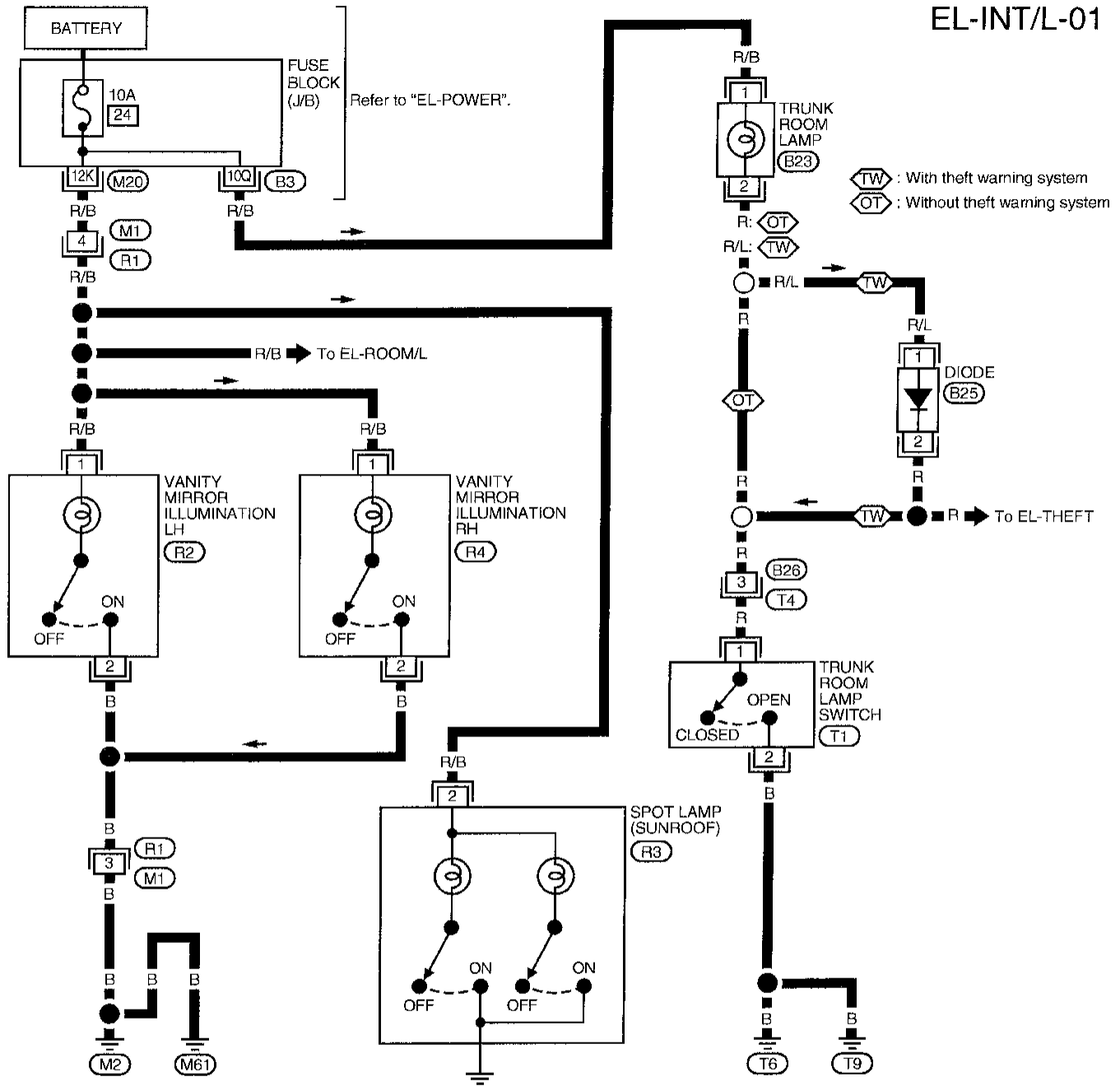

SPOT, TRUNK ROOM AND VANITY MIRROR LAMPS

NOTES

GI

MA

EM

LC

EC

FE

CL

MT

AT

FA

PA

BR

ST

RS

BT

HA

EL

IDX

METER AND GAUGES

Component Parts and Harness Connector Location

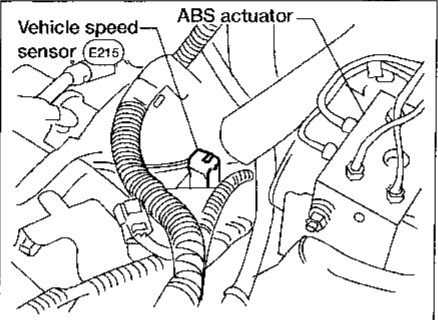
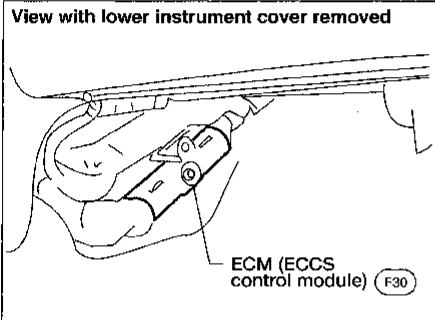
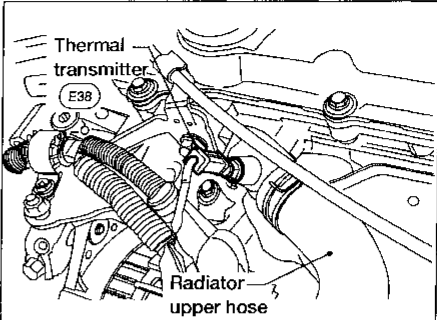
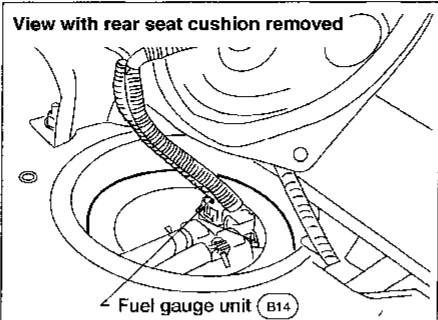
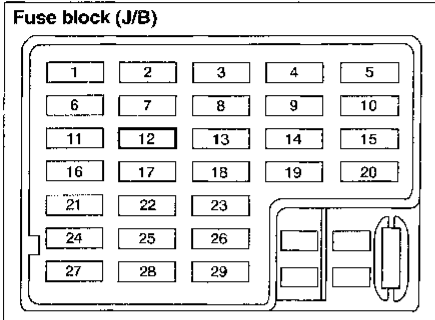

System Description

POWER SUPPLY AND GROUND CIRCUIT

With the ignition switch in the ON or START position, power is supplied:

- through 10A fuse [No. 12, located in the fuse block (J/B)]
- to combination meter terminals ②, ②② and ④③.

Ground is supplied:

- to combination meter terminal ③⑧
- through body grounds M2 and M61.

FUEL GAUGE

The fuel gauge indicates the approximate fuel level in the fuel tank.

The fuel gauge is regulated by a variable ground signal supplied:

- to combination meter terminal ④ for the fuel gauge
- from terminal ⑥ of the fuel tank gauge unit
- through terminal ⑤ of the fuel tank gauge unit and
- through body grounds B13 and B19.

WATER TEMPERATURE GAUGE

The water temperature gauge indicates the engine coolant temperature. The reading on the gauge is based on the resistance of the thermal transmitter.

As the temperature of the coolant increases, the resistance of the thermal transmitter decreases. A variable ground is supplied to terminal ③⑦ of the combination meter for the water temperature gauge. The needle on the gauge moves from "C" to "H".

TACHOMETER

The tachometer indicates engine speed in revolutions per minute (rpm).

The tachometer is regulated by a signal:

- from terminal ③ of the ECM (ECCS control module)
- to combination meter terminal ③⑤ for the tachometer.

SPEEDOMETER

The vehicle speed sensor provides a voltage signal to the combination meter for the speedometer.

The voltage is supplied:

- to combination meter terminals ③ and ①⑨ for the speedometer
- from terminals ① and ② of the vehicle speed sensor.

The speedometer converts the voltage into the vehicle speed displayed.

GI

MA

EM

LC

EC

FE

CL

MT

AT

FA

RA

BR

ST

RS

BT

HA

EL

IDX

METER AND GAUGES

System Description (Cont'd)

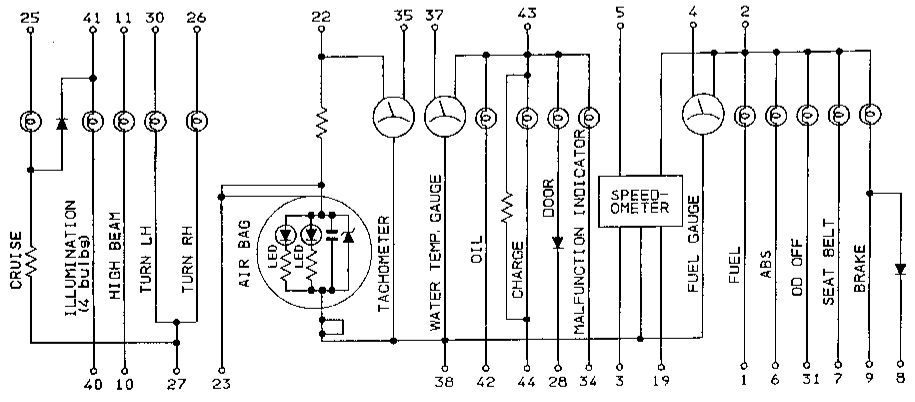
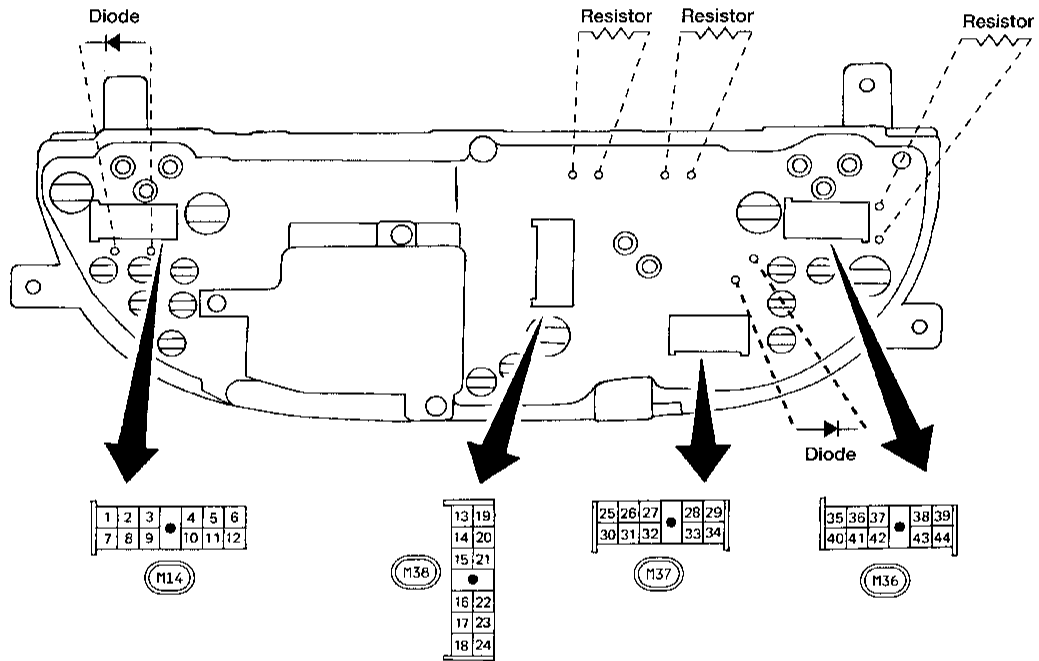
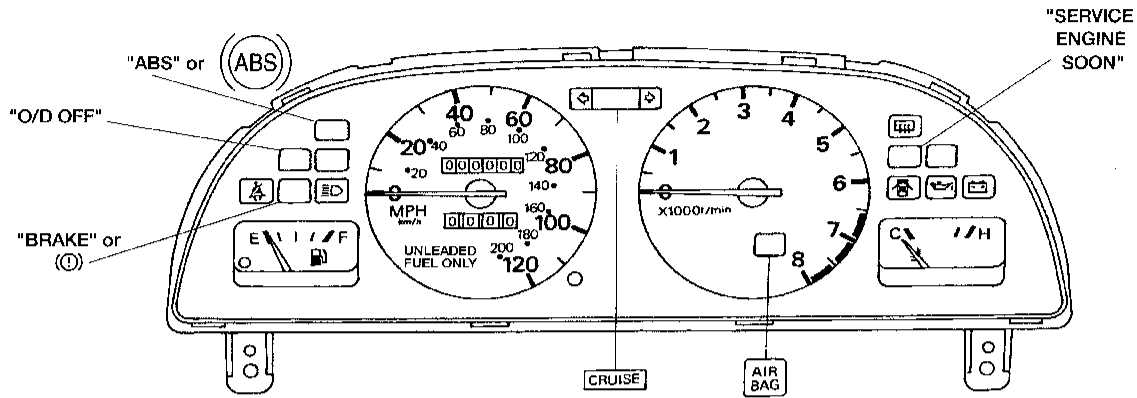

METER AND GAUGES

Wiring Diagram — METER —

EL-METER-01

GI
MA
EM
LC
EC
FE
CL
MT
AT
FA
RA
BR
ST
RS
BT

EL

FDX

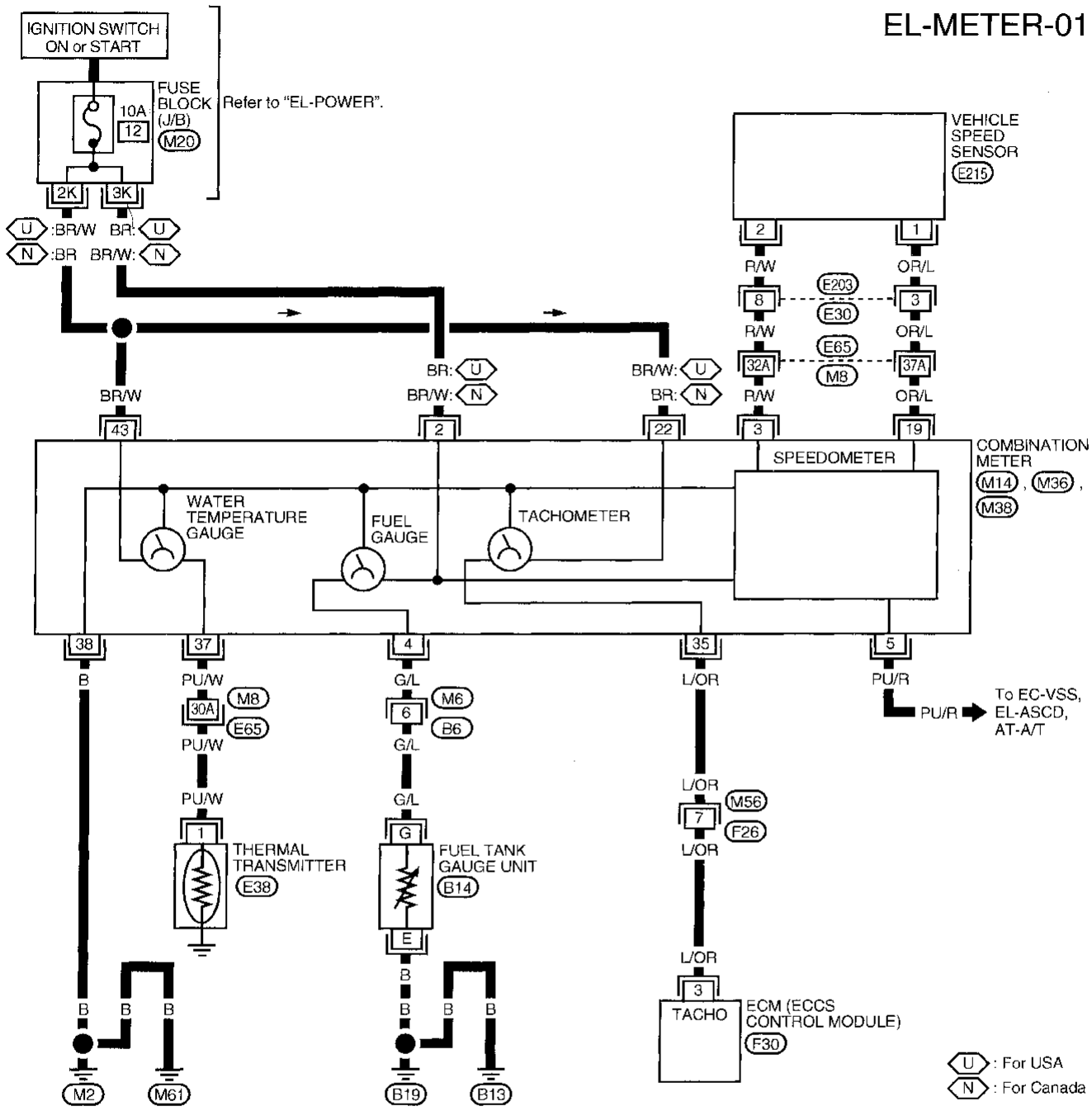

Refer to last page (Foldout page).

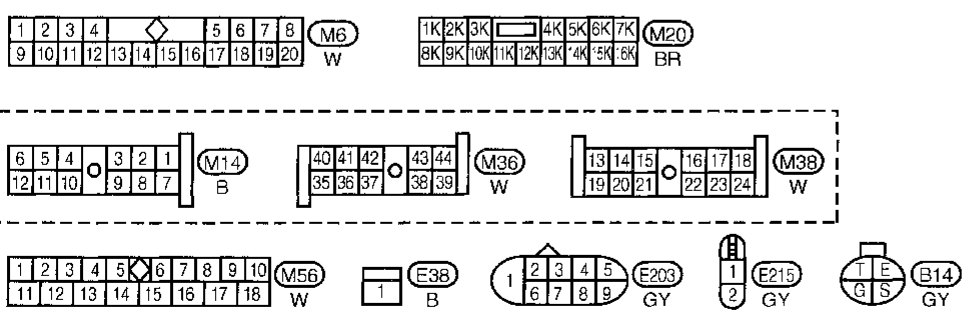

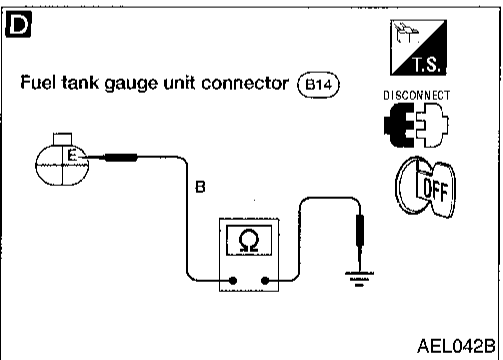
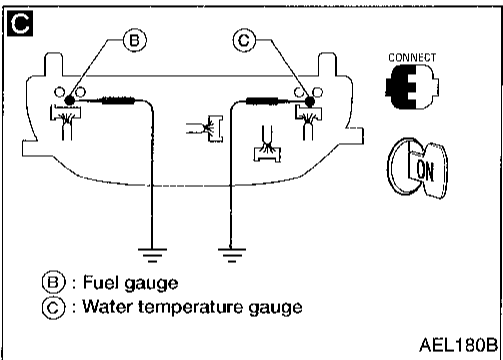
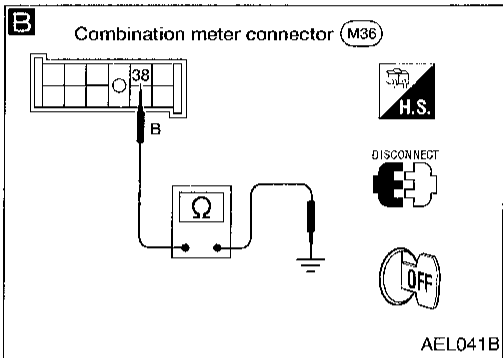
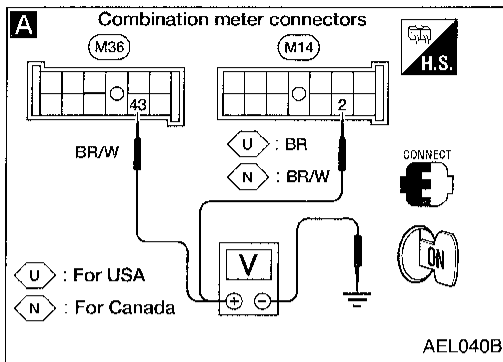

Trouble Diagnoses

INSPECTION/FUEL GAUGE AND/OR WATER TEMPERATURE GAUGE

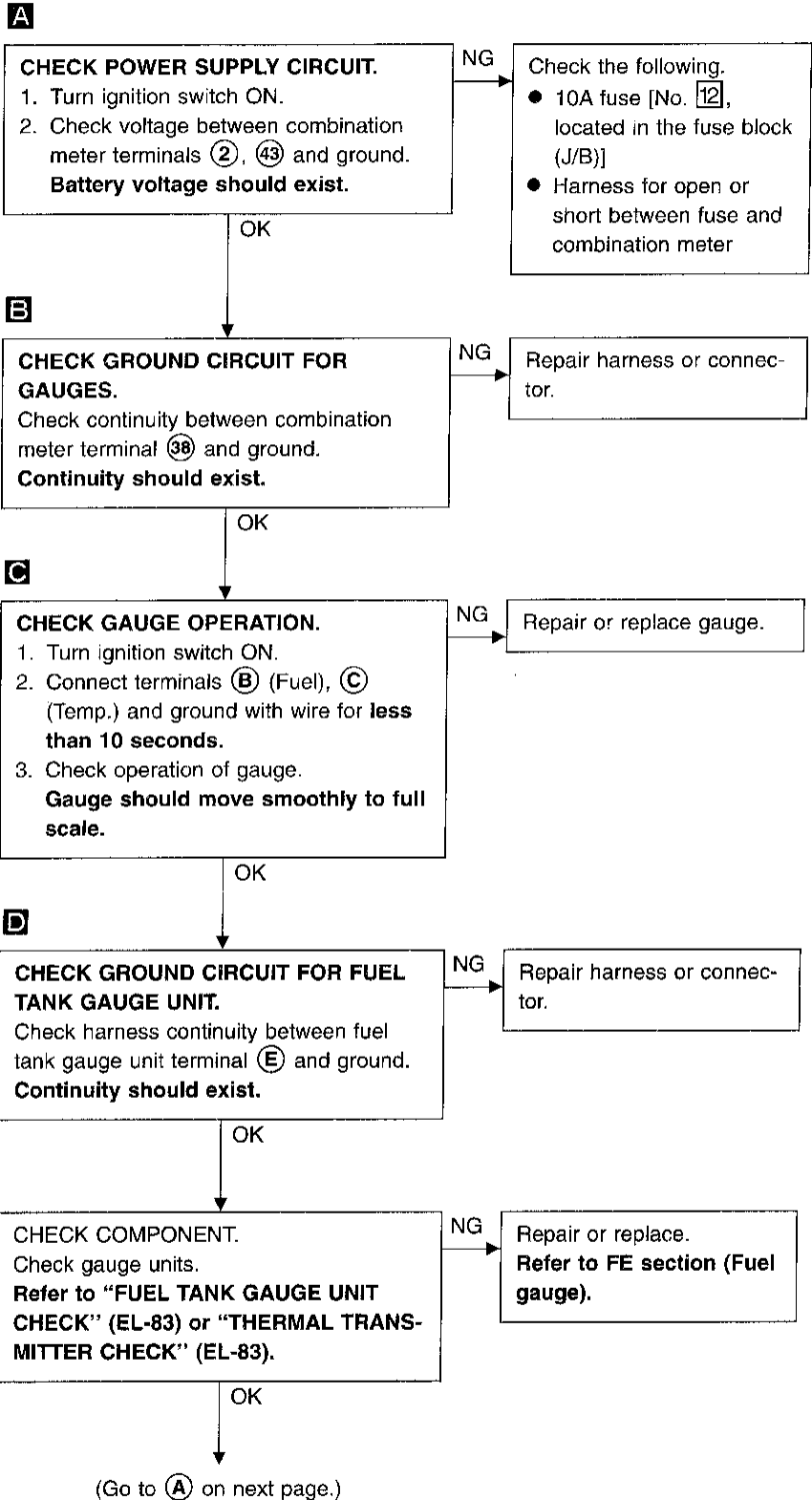

METER AND GAUGES

Trouble Diagnoses (Cont'd)

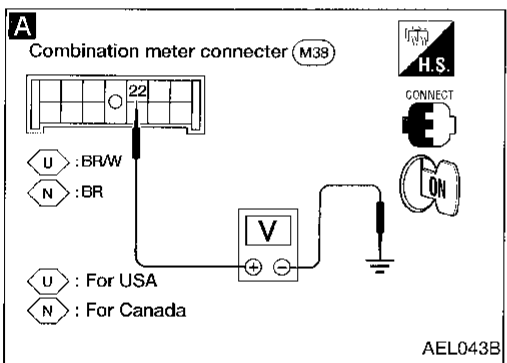
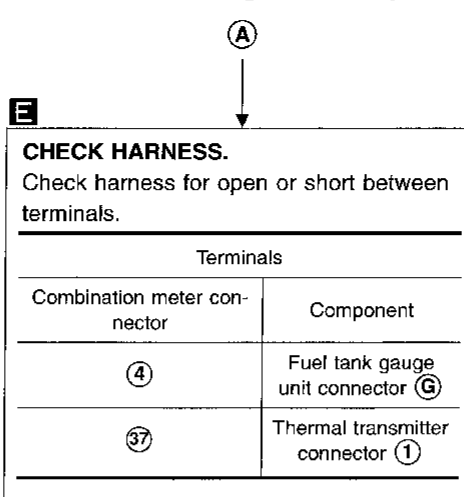
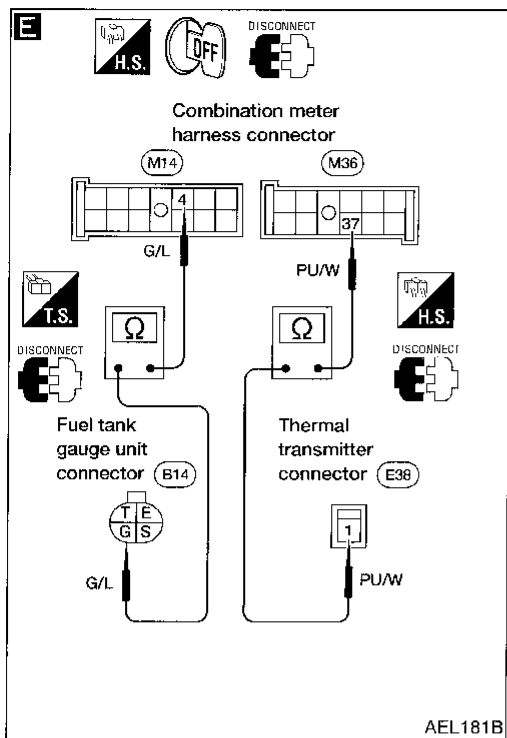

INSPECTION/TACHOMETER

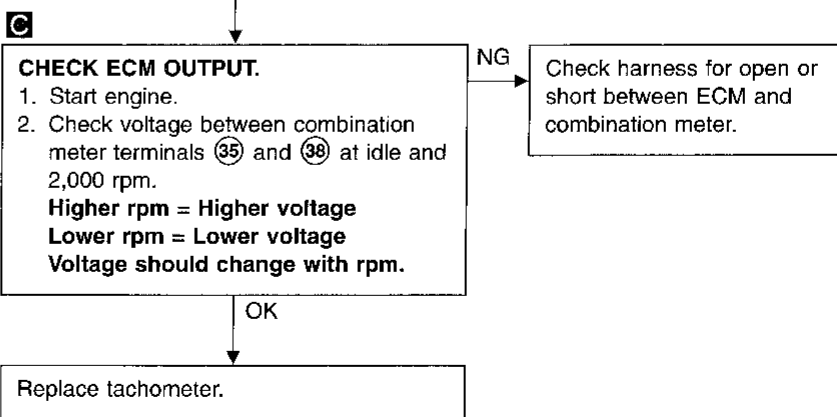
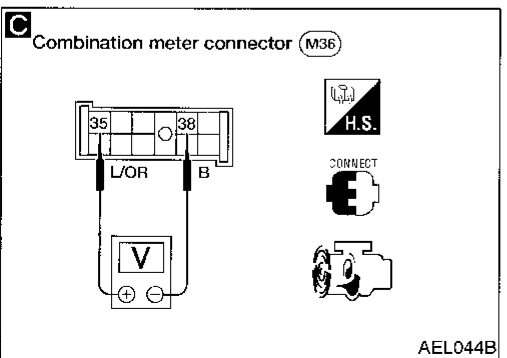
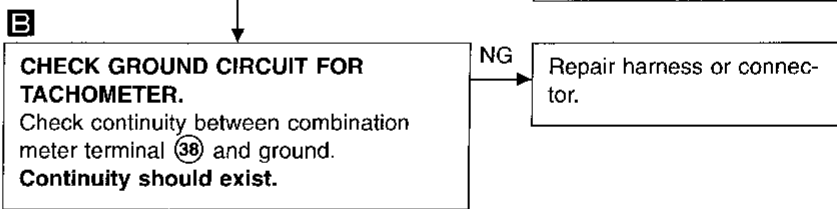
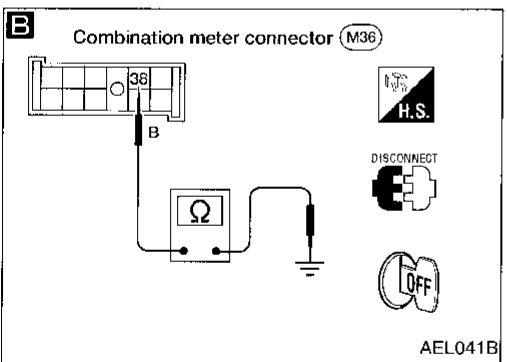
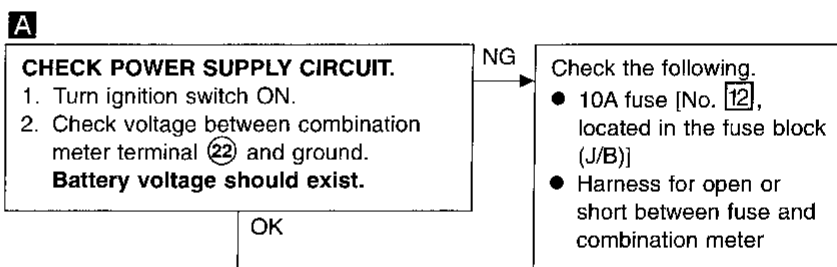

GI
MA
EM
LC
EC
FE
CL
MT
AT
FA
RA
BR
ST
RS
BT
HA
EL
IDX

METER AND GAUGES

Trouble Diagnoses (Cont'd)

INSPECTION/SPEEDOMETER AND VEHICLE SPEED SENSOR

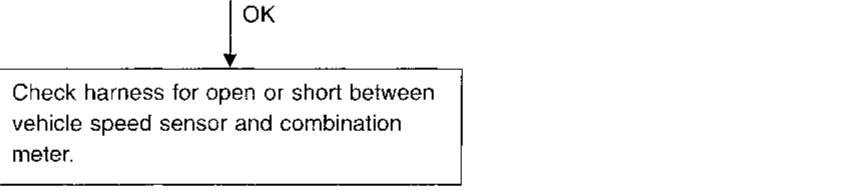
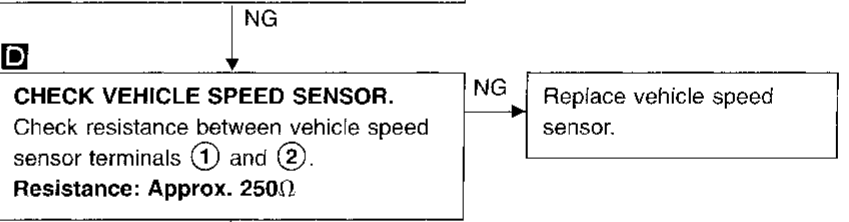
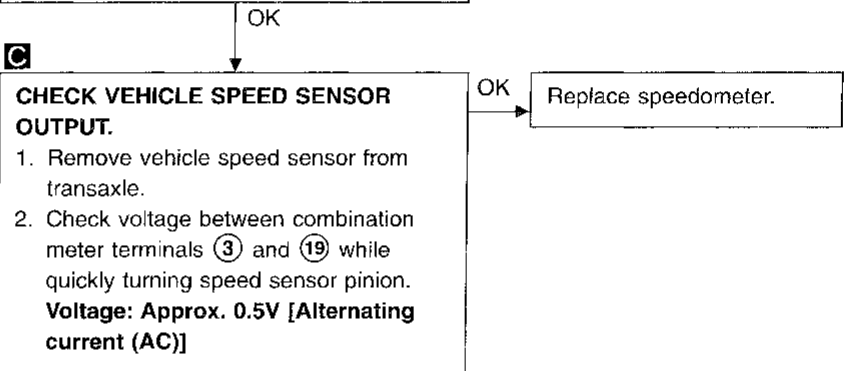
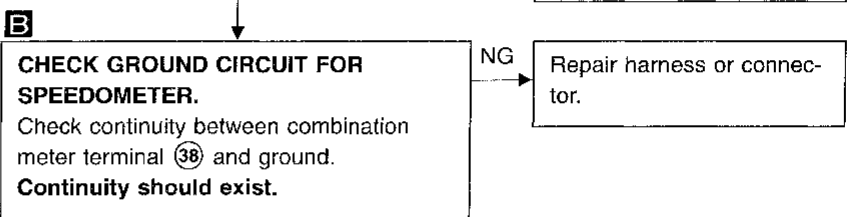
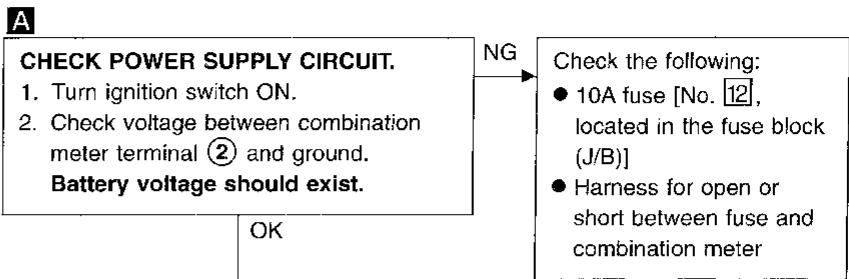
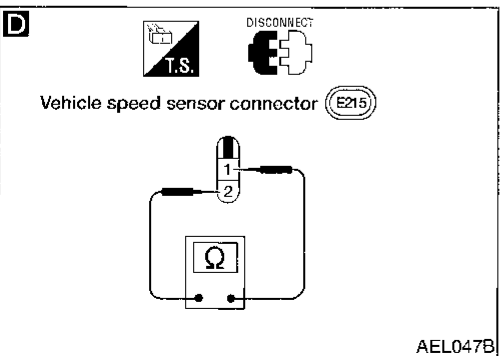
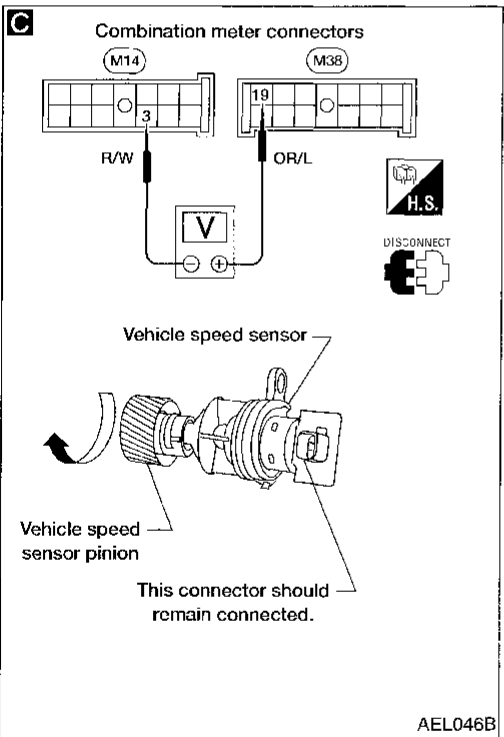
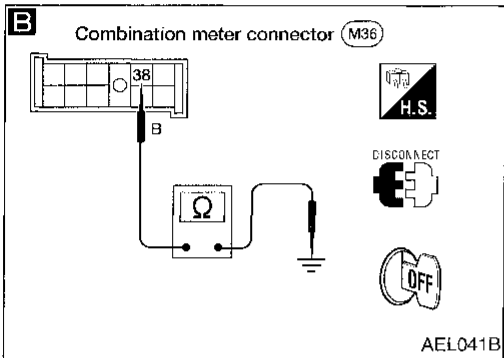
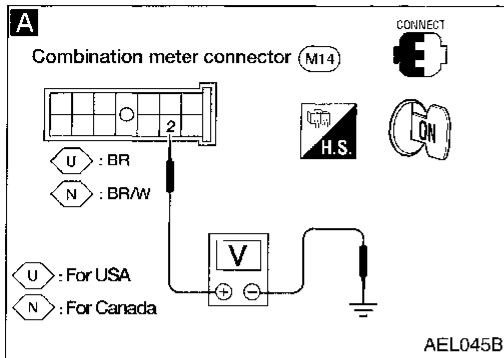

METER AND GAUGES

Trouble Diagnoses (Cont'd) FUEL TANK GAUGE UNIT CHECK

- For removal, refer to FE section.
- Check the resistance between terminals **(G)** and **(E)**.

Ohmmeter		Float position		Resistance value (Ω)
(+)	(-)	mm (in)		
(G)	(E)	*3	Full	80.5 (3.169)
		*2	1/2	29.4 (1.157)
		*1	Empty	19 (0.748)

*1 and *3: When float rod is in contact with stopper.

GI

MA

EM

LC

EC

FE

CL

MT

AT

FA

RA

BR

ST

RS

BT

HA

EL

IDX

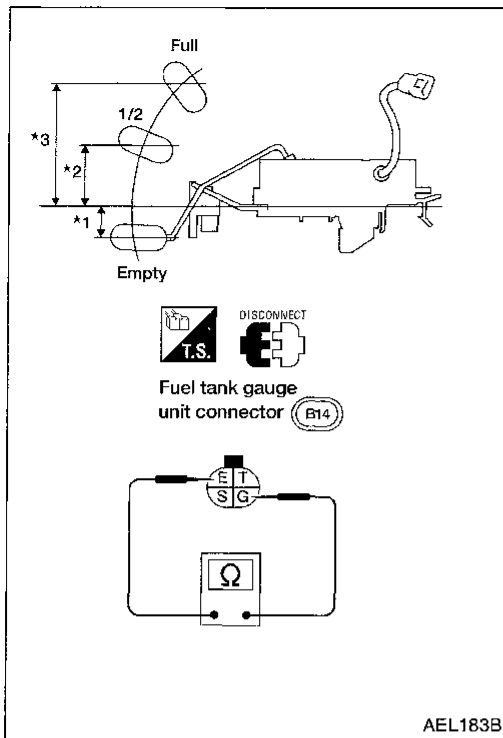

AEL183B

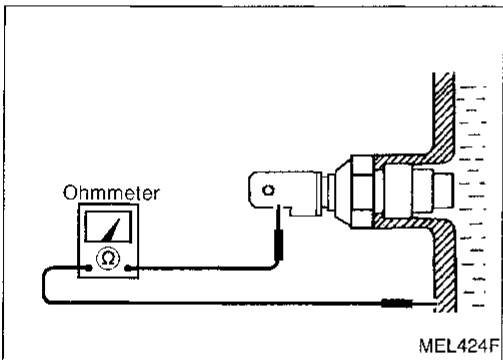

MEL424F

THERMAL TRANSMITTER CHECK

Check the resistance between the terminals of thermal transmitter and body ground.

Water temperature	Resistance (Ω)
60°C (140°F)	Approx. 170 - 210
100°C (212°F)	Approx. 47 - 53

VEHICLE SPEED SENSOR SIGNAL CHECK

- Remove vehicle speed sensor from transmission.
- Turn vehicle speed sensor pinion quickly and measure voltage between terminals ① and ②.

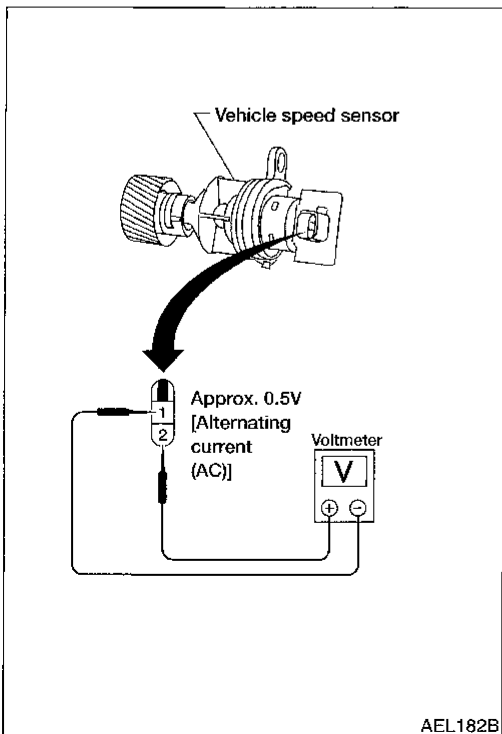

AEL182B

System Description

With the ignition switch in the ON or START position, power is supplied:

- through 10A fuse (No. 12, located in the fuse block [J/B])
- to combination meter terminals 2, 22 and 43.

Ground is supplied:

- to combination meter terminal 38
- through body grounds M2 and M61 .

Ground is supplied:

- to fuel tank gauge unit terminal E and
- seat belt buckle switch terminal 2
- through body grounds B13 and B19 .

Ground is supplied:

- to brake fluid level switch terminal 2
- through body grounds E10 and E34 .

AIR BAG WARNING LAMP

During prove out or when an air bag malfunction occurs, the ground path is interrupted:

- from the air bag diagnosis sensor unit terminal 15
- to combination meter terminal 23.

Ground is supplied:

- through combination meter terminal 39.

With power and ground supplied, the air bag warning lamp (LEDs) illuminate.

For further information, refer to RS section (“TROUBLE DIAGNOSES”).

DOOR AJAR WARNING LAMP

When a door is open, ground is supplied:

- to combination meter terminal 28
- from smart entrance control unit terminal 9 (With power door locks)
- from door switches terminal 1 (Without power door locks).

With power and ground supplied, the door ajar warning lamp illuminates.

MALFUNCTION INDICATOR LAMP

During prove out or when an engine control malfunction occurs, ground is supplied:

- to combination meter terminal 34
- from ECM terminal 18.

With power and ground supplied, the malfunction indicator lamp illuminates.

For further information, refer to EC section [“Malfunction Indicator Lamp (MIL)”, “ON BOARD DIAGNOSTIC SYSTEM DESCRIPTION”].

LOW OIL PRESSURE WARNING LAMP

Low oil pressure causes oil pressure switch terminal 1 to provide ground to combination meter terminal 42.

With power and ground supplied, the low oil pressure warning lamp illuminates.

WARNING LAMPS

System Description (Cont'd)

CHARGE WARNING LAMP

During prove out or when a generator malfunction occurs, ground is supplied:

- to combination meter terminals ④ and ⑧
- from generator terminal ③.

With power and ground supplied, the charge warning lamp and brake lamp illuminate.

BRAKE WARNING LAMP

When the parking brake is applied, or the brake fluid level is low, ground is supplied:

- to combination meter terminal ⑨
- from parking brake switch terminal ①, or
- brake fluid level switch terminal ①.

With power and ground supplied, the brake warning lamp illuminates.

LOW FUEL LEVEL WARNING LAMP

The amount of fuel in the fuel tank is determined by the fuel level sensor in the fuel tank. A signal is sent from fuel tank gauge unit terminal ⑤ to combination meter terminal ①. The fuel level sensor will illuminate the low fuel level warning lamp when the fuel level is low.

With power and ground supplied, the low fuel level warning lamp illuminates.

SEAT BELT WARNING LAMP

When the driver's seat belt is unfastened, ground is supplied:

- to combination meter terminal ⑦
- from seat belt buckle switch terminal ①.

With power and ground supplied, the seat belt warning lamp illuminates.

ABS WARNING LAMP

During prove out or when an ABS malfunction occurs, ground is supplied:

- to combination meter terminal ⑥
- from ABS control unit terminal ⑩.

With power and ground supplied, the ABS warning lamp illuminates.

For further information, refer to BR section ("Self-diagnosis", "TROUBLE DIAGNOSES").

GI

MA

EM

LC

EC

FE

CL

MT

AT

FA

RA

BR

ST

RS

BT

HA

EL

IDX

WARNING LAMPS

Schematic

- ① : For U.S.A.
- ② : For Canada
- ③ : With power door locks
- ④ : Without power door locks
- ⑤ : With smart entrance
- ⑥ : Without smart entrance

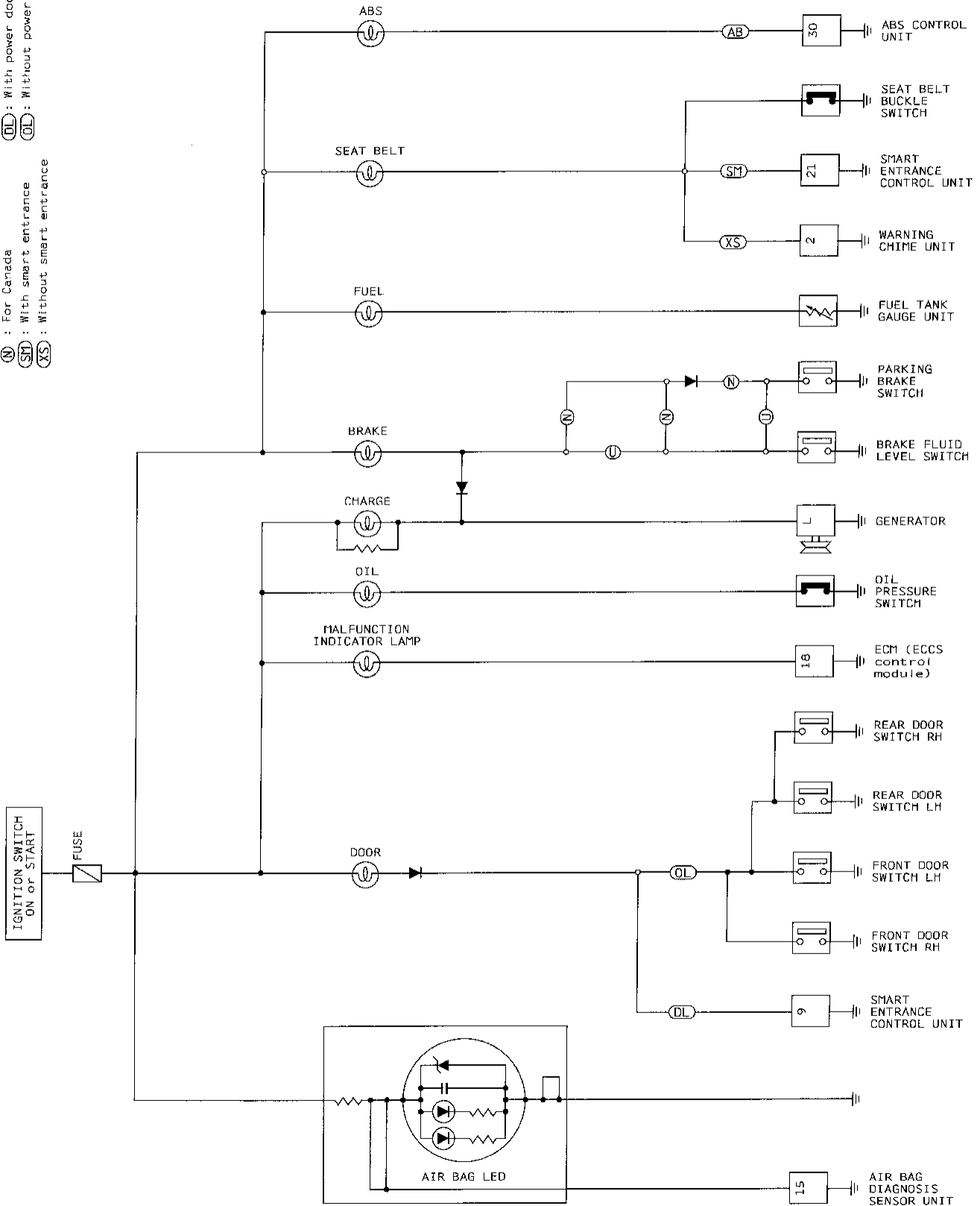

AEL979A

WARNING LAMPS

Wiring Diagram — WARN —

EL-WARN-01

GI

MA

EM

LC

EC

FE

CL

MT

AT

FA

RA

BR

ST

RS

BT

HA

EL

IDX

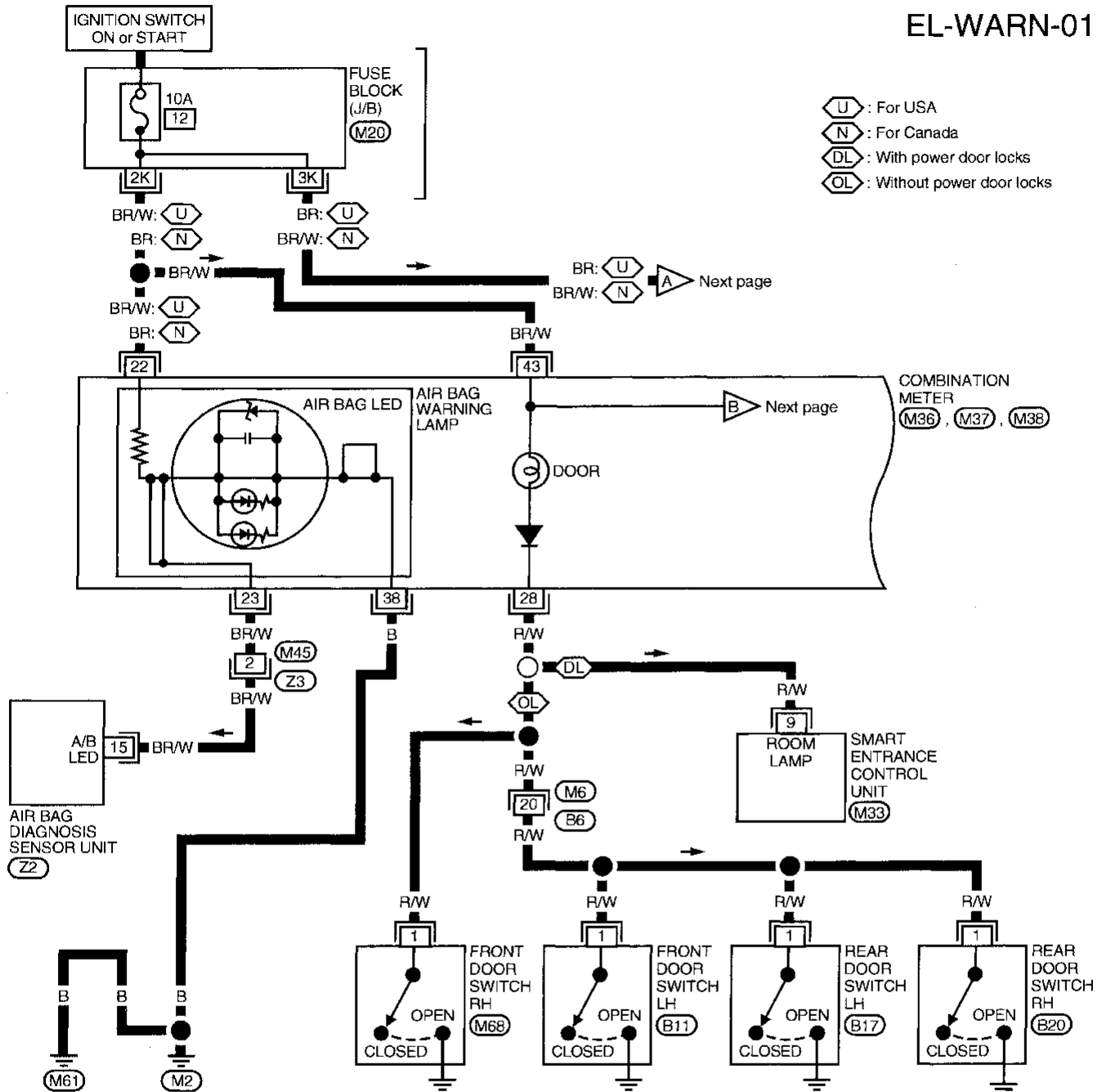

1	2	3	4	5	6	7	8	9	10	(M6)
11	12	13	14	15	16	17	18	19	20	W

1K	2K	3K	4K	5K	6K	7K	(M20)		
8K	9K	10K	11K	12K	13K	14K	15K	16K	BR

24	25	26	27	28	29	30	31	32	33	34	35	36	6	7	8	9	10	(M33)
11	12	13	14	15	16	17	18	19	20	21	22	23	1	2	3	4	5	W

40	41	42	43	44	(M36)	30	31	32	33	34	(M37)	13	14	15	16	17	18	(M38)
35	36	37	38	39	W	25	26	27	28	29	B	19	20	21	22	23	24	B

1	(M68)	(B17)	(B20)	2	1	(B11)	17	9	14	18	7	15	20	1	21	8	22	10	(Z2)	1	2	3	4	(Z3)				
BR	BR	BR		3	B		5	16	3	19	11	13	12	4	2	6	Y			5	6	7	8	9	10	11	12	W

WARNING LAMPS

Wiring Diagram — WARN — (Cont'd)

EL-WARN-03

- : With ABS
- : With smart entrance
- : Without smart entrance

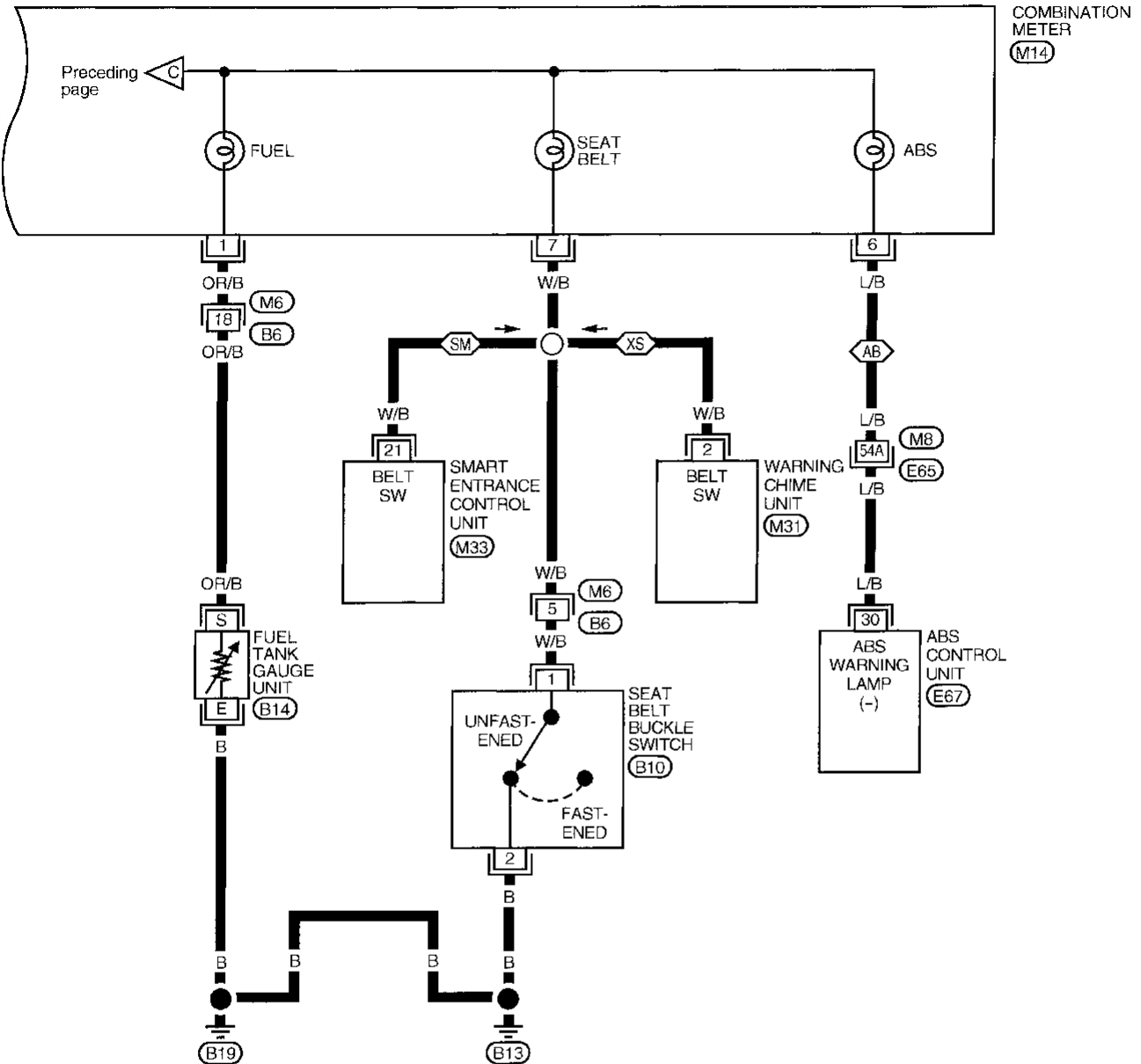

GI
MA
EM
LC
EC
FE
CL
MT
AT
FA
RA
BR
ST
RS
BT
HA
EL
IDX

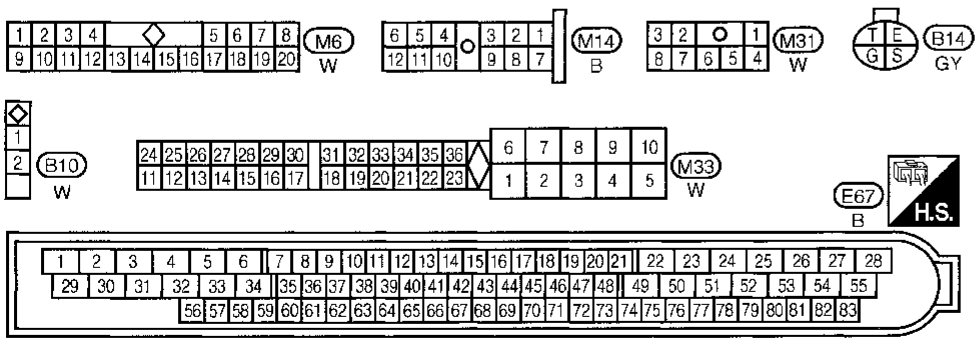

Refer to last page (Foldout page).
M8, E65

Electrical Components Inspection

FUEL WARNING LAMP SENSOR CHECK

- It will take a short time for the bulb to light.

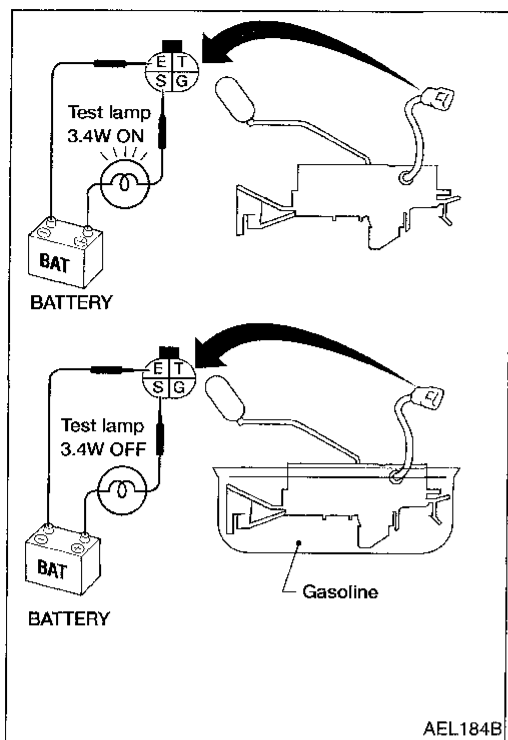

AEL184B

OIL PRESSURE SWITCH CHECK

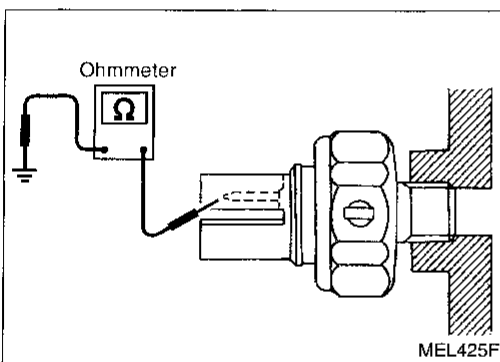

MEL425F

	Oil pressure kPa (kg/cm ² , psi)	Continuity
Engine start	More than 10 - 20 (0.1 - 0.2, 1 - 3)	NO
Engine stop	Less than 10 - 20 (0.1 - 0.2, 1 - 3)	YES

Check the continuity between the terminals of oil pressure switch and body ground.

DIODE CHECK

- Check continuity using an ohmmeter.
- Diode is functioning properly if test results are as shown in the figure at left.

NOTE: Specification may vary depending on the type of tester. Before performing this inspection, be sure to refer to the instruction manual for the tester to be used.

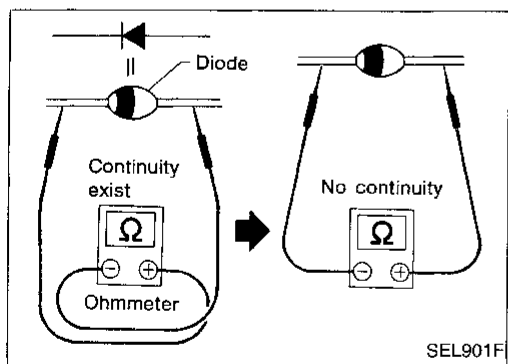

SEL901F

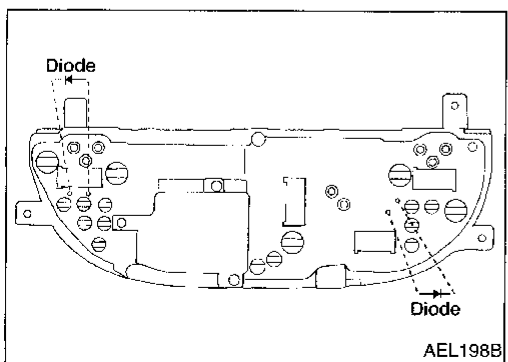

AEL198B

- Diodes for warning lamps are built into the combination meter printed circuit.

WARNING CHIME

Component Parts and Harness Connector Location

GI
MA
EM
LC
EC
FE
CL
MT
AT
FA
RA
BR
ST
RS
BT
HA
EL
IDX

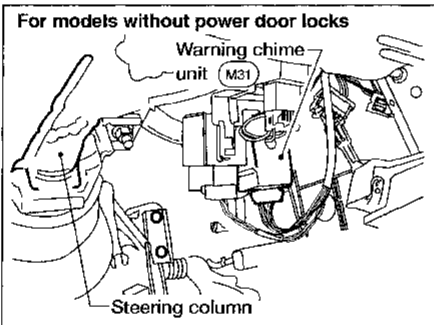
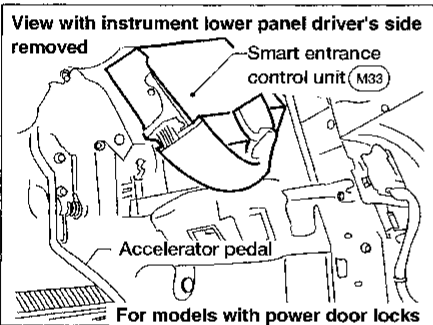
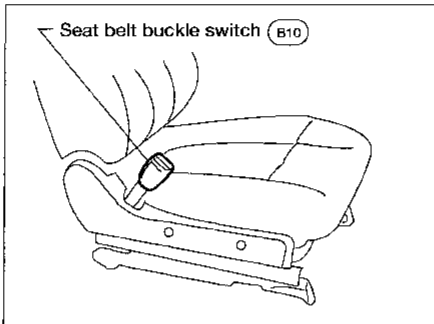
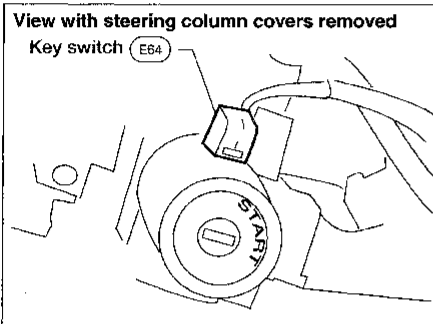
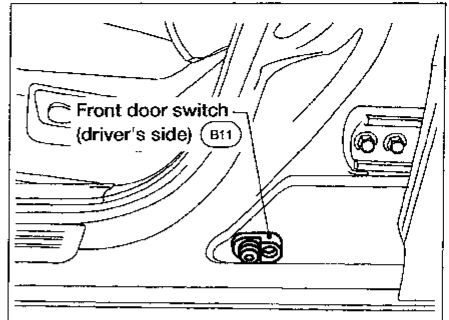
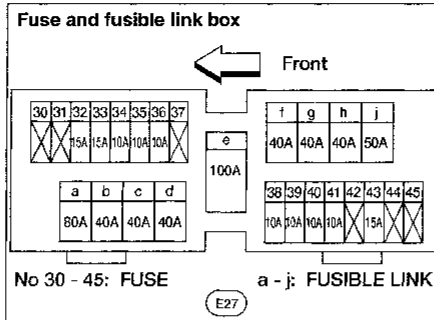
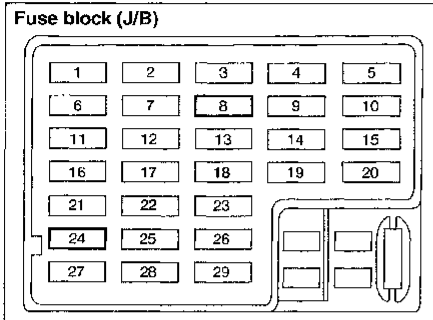

System Description

MODELS WITH POWER DOOR LOCKS

The warning chime is integral with the smart entrance control unit, which controls its operation.

Power is supplied at all times:

- through 10A fuse [No. 24], located in the fuse block (J/B)]
- to key switch terminal ②.

Power is supplied at all times:

- through 10A fuse (No. 34), located in the fuse and fusible link box)
- to lighting switch terminal ⑩.

Power is supplied at all times:

- through 40A fusible link (letter [d], located in the fuse and fusible link box).
- to circuit breaker - 1 terminal ①
- through circuit breaker - 1 terminal ②
- to smart entrance control unit terminal ①.

With the ignition switch in the ON or START position, power is supplied:

- through 10A fuse [No. 8], located in the fuse block (J/B)]
- to smart entrance control unit terminal ⑩.

Ground is supplied to smart entrance control unit terminal ⑩ through body grounds M2 and M61 .

When a signal, or combination of signals, is received by the smart entrance control unit, the warning chime will sound.

Ignition key warning chime

With the key in the ignition key cylinder, the ignition switch in the OFF or ACC position, and the driver's door open, the warning chime will sound. A battery positive voltage is supplied:

- from key switch terminal ①
- to smart entrance control unit terminal 24.

Ground is supplied:

- from front door switch LH terminal ①
- to smart entrance control unit terminal 15.

Light warning chime

With ignition switch in the OFF or ACC position, driver's door open, and lighting switch in 1ST or 2ND position, warning chime will sound. A battery positive voltage is supplied:

- from lighting switch terminal 12
- to smart entrance control unit terminal 25

Ground is supplied:

- from front door switch LH terminal ①
- to smart entrance control unit terminal 15.

Seat belt warning chime

The warning chime sounds for about 6 seconds when ignition switch is turned from OFF to ON and seat belt is unfastened.

Ground is supplied:

- from seat belt buckle switch terminal ①
- to smart entrance control unit terminal 21.

Seat belt buckle switch terminal ② is grounded through body grounds B13 and B19 .

WARNING CHIME

System Description (Cont'd)

MODELS WITHOUT POWER DOOR LOCKS

The warning chime is integral with the warning chime unit, which controls its operation.

Power is supplied at all times:

- through 10A fuse [No. 24], located in the fuse block (J/B)
- to key switch terminal ②.

Power is supplied at all times:

- through 10A fuse (No. 34), located in the fuse and fusible link box)
- to lighting switch terminal ⑪.

With the ignition switch in the ON or START position, power is supplied:

- through 10A fuse [No. 8], located in the fuse block (J/B)
- to warning chime unit terminal ①.

Ground is supplied to warning chime unit terminal ⑧ through body grounds M2 and M61.

When a signal, or combination of signals, is received by the warning chime unit, the warning chime will sound.

Ignition key warning chime

With the key in the ignition switch in the OFF or ACC position, and the driver's door open, the warning chime will sound. A battery positive voltage is supplied:

- from key switch terminal ①
- to warning chime unit terminal ⑤.

Ground is supplied:

- to warning chime unit terminal ⑦
- from front door switch LH terminal ②.

Front door switch LH terminal ③ is grounded through body grounds B13 and B19.

Light warning chime

With ignition switch OFF or ACC, driver's door open, and lighting switch in 1ST or 2ND position, warning chime will sound. A battery positive voltage is supplied:

- from lighting switch terminal ⑫
- to warning chime unit terminal ④.

Ground is supplied:

- to warning chime unit terminal ⑦
- from front door switch LH terminal ②.

Front door switch LH terminal ③ is grounded through body grounds B13 and B19.

Seat belt warning chime

With ignition switch turned to ON or START and seat belt unfastened, warning chime will sound for approximately 6 seconds.

Ground is supplied:

- to warning chime unit terminal ②
- from seat belt buckle switch terminal ①.

Seat belt buckle switch terminal ② is grounded through body grounds B13 and B19.

GI

MA

EM

LC

EC

FE

CL

MT

AT

FA

RA

BR

ST

RS

BT

HA

EL

IDX

WARNING CHIME

Wiring Diagram — CHIME —

MODELS WITH POWER DOOR LOCKS

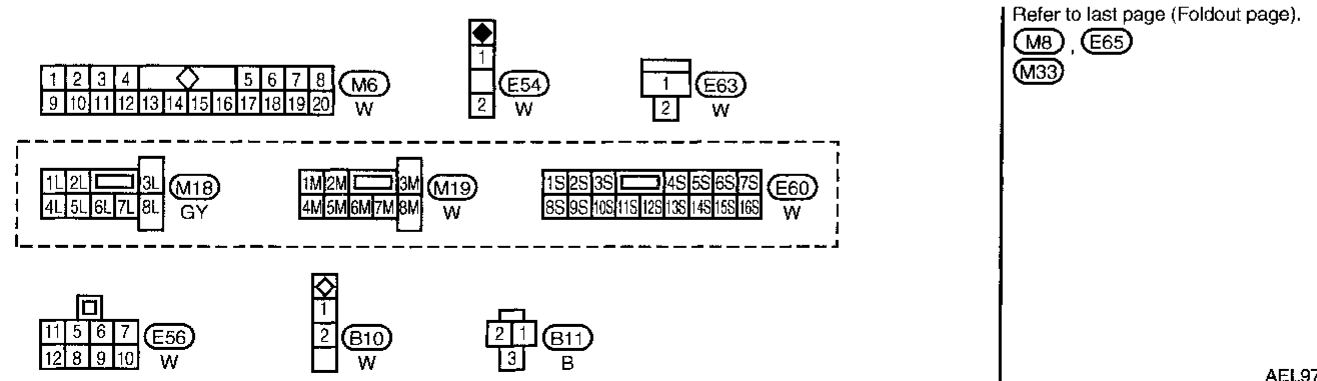
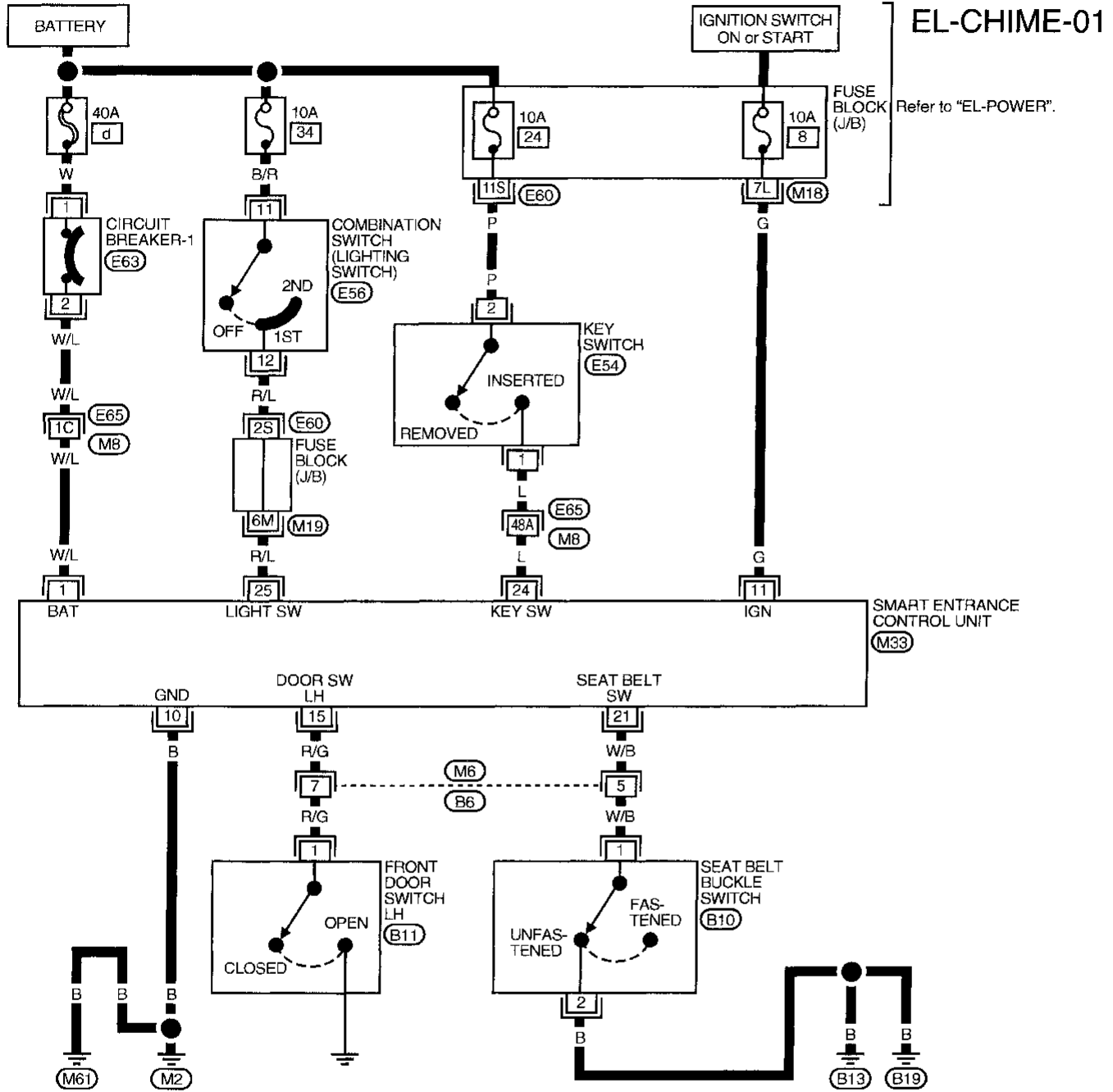

WARNING CHIME

Wiring Diagram — CHIME — (Cont'd)

MODELS WITHOUT POWER DOOR LOCKS

EL-CHIME-02

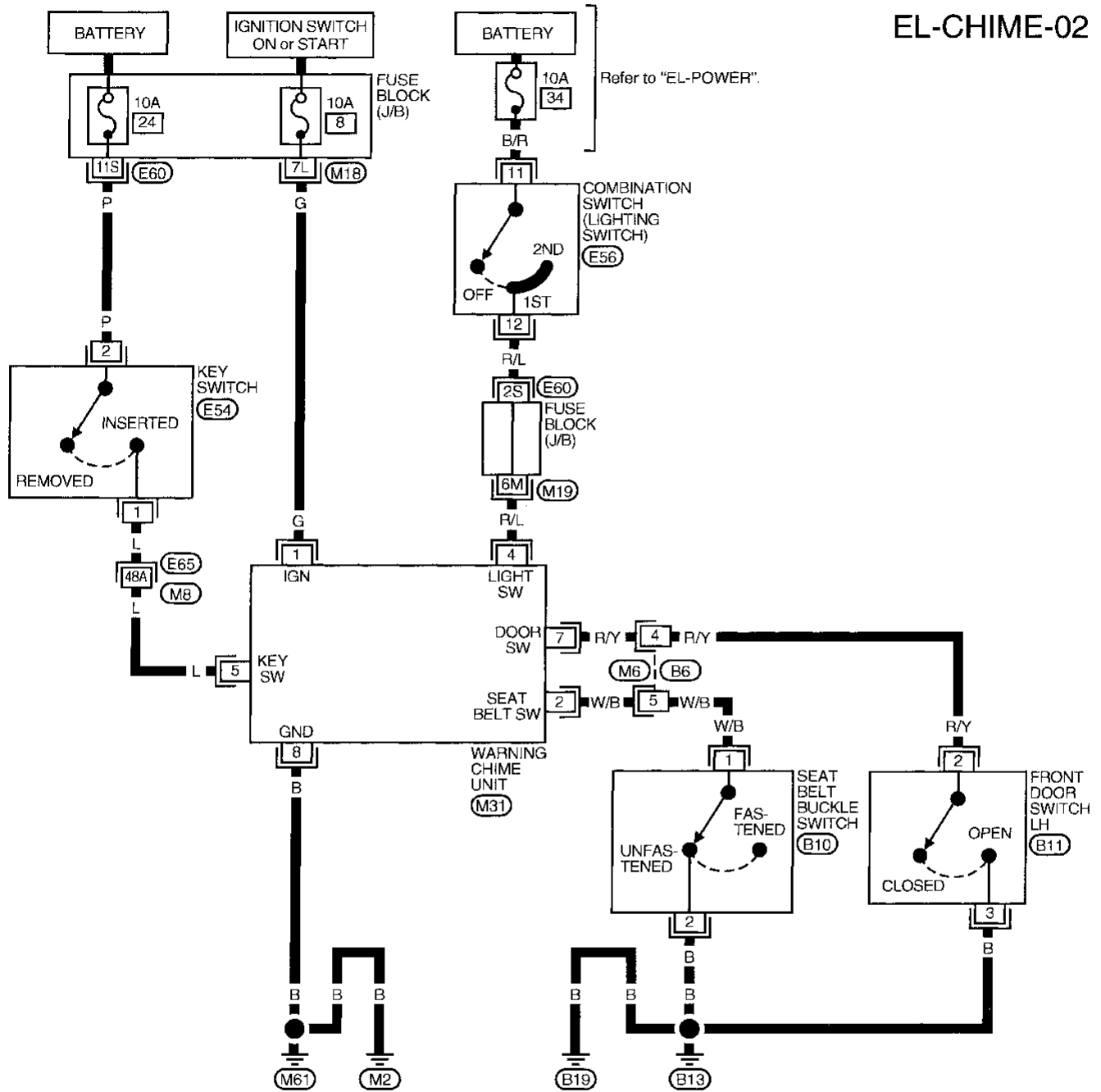

GI
MA
EM
LC
EC
FE
CL
MT
AT
FA
RA
BR
ST
RS
BT
HA

Refer to last page (Foldout page).

(M8), (E65)

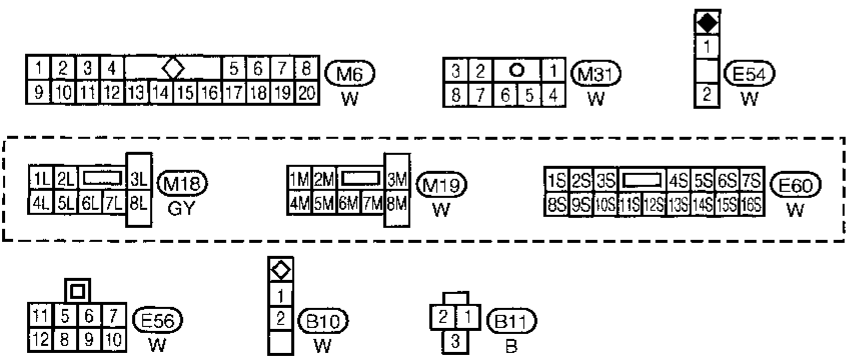

EL

IDX

WARNING CHIME

Trouble Diagnoses

SYMPTOM CHART

REFERENCE PAGE	EL-97	EL-98	EL-99	EL-100	EL-101
SYMPTOM	POWER SUPPLY AND GROUND CIRCUIT CHECK	DIAGNOSTIC PROCEDURE 1 (Lighting switch input signal check)	DIAGNOSTIC PROCEDURE 2 (Key switch input signal check)	DIAGNOSTIC PROCEDURE 3 (Seat belt buckle switch input signal check)	DIAGNOSTIC PROCEDURE 4 (Driver side door switch input signal check)
Light warning chime does not activate.	X	X			X
Ignition key warning chime does not activate.	X		X		X
Seat belt warning chime does not activate.	X			X	X
All warning chimes do not activate.	X				X

WARNING CHIME

Trouble Diagnoses (Cont'd)

MAIN POWER SUPPLY AND GROUND CIRCUIT CHECK

Main power supply circuit check

- Models with power door locks

Terminals		Ignition switch position		
⊕	⊖	OFF	ACC	ON
①	Ground	Battery voltage	Battery voltage	Battery voltage
⑪	Ground	0V	0V	Battery voltage

- Models without power door locks

Terminals		Battery voltage existence condition		
		Ignition switch position		
⊕	⊖	OFF	ACC	ON
①	Ground	0V	0V	Battery voltage

Ground circuit check

- Models with power door locks

Terminals	Continuity
⑩ - Ground	Yes

- Models without power door locks

Terminals	Continuity
⑧ - Ground	Yes

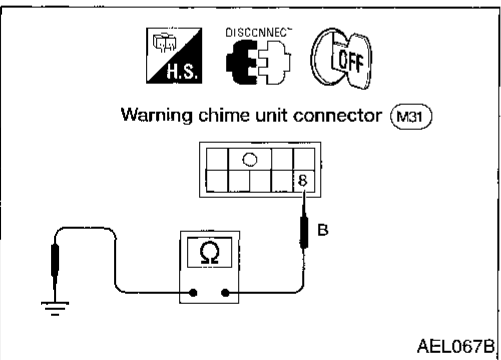
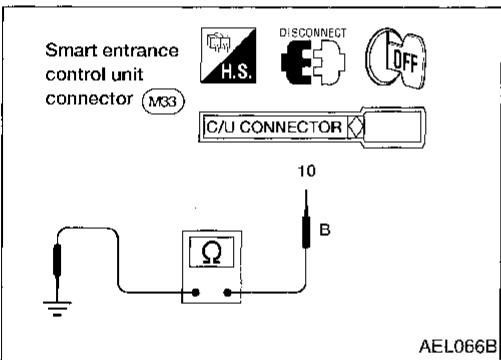
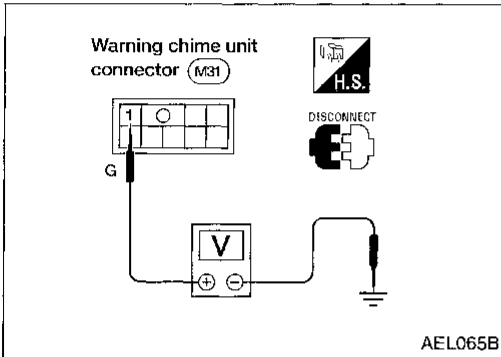
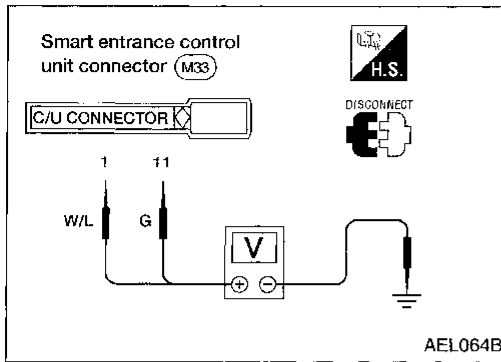

GI

MA

EM

LC

EC

FE

CL

WT

AT

FA

RA

BR

ST

RS

BT

HA

EL

IDX

WARNING CHIME

Trouble Diagnoses (Cont'd)

DIAGNOSTIC PROCEDURE 1

(Lighting switch input signal check)

Models with power door locks

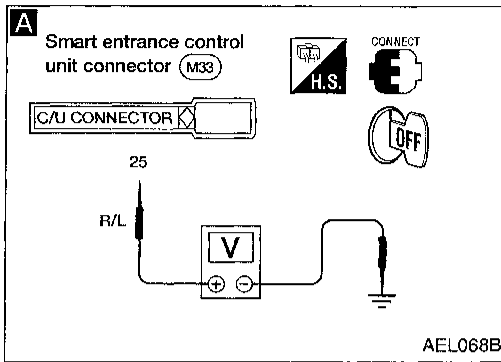

A

CHECK LIGHTING SWITCH INPUT SIGNAL.

Check voltage between control unit terminal (25) and ground.

Condition of lighting switch	Voltage [V]
1ST or 2ND	Approx. 12
OFF	0

NG

Check the following.

- 10A fuse (No. 34, located in the fuse and fusible link box)
- Harness for open or short between control unit and lighting switch

OK

Go to Diagnostic Procedure 4, EL-101.

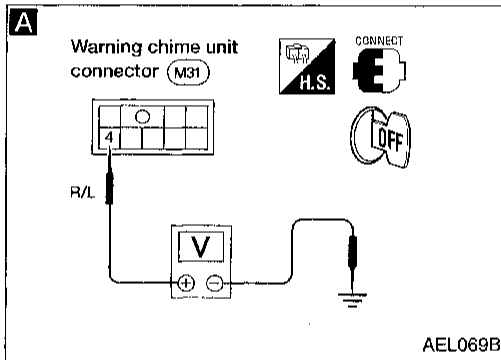

Models without power door locks

A

CHECK LIGHTING SWITCH INPUT SIGNAL.

Check voltage between warning chime unit terminal (4) and ground.

Condition of lighting switch	Voltage [V]
1ST or 2ND	Approx. 12
OFF	0

NG

Check the following.

- 10A fuse (No. 34, located in the fuse and fusible link box)
- Harness for open or short between warning chime unit and lighting switch

OK

Go to Diagnostic Procedure 4, EL-101.

WARNING CHIME

Trouble Diagnoses (Cont'd)

DIAGNOSTIC PROCEDURE 2

(Key switch input signal check)

Models with power door locks

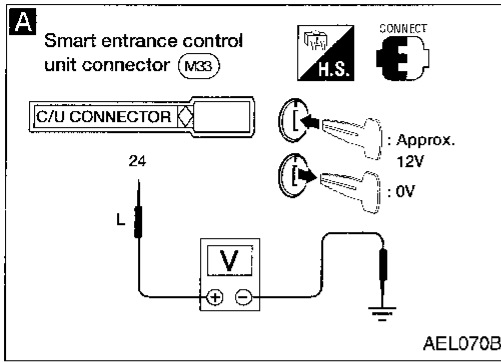

A

CHECK KEY SWITCH INPUT SIGNAL.

Check voltage between control unit terminal (24) and ground.

Condition of key switch	Voltage [V]
Key is inserted.	Approx. 12
Key is withdrawn.	0

NG

Check the following.

- Key switch
Refer to "Electrical Components Inspection" (EL-102).
- 10A fuse [No. 24], located in fuse block (J/B)]
- Harness for open or short between key switch and fuse
- Harness for open or short between control unit and key switch

OK

Go to Diagnostic Procedure 4, EL-101.

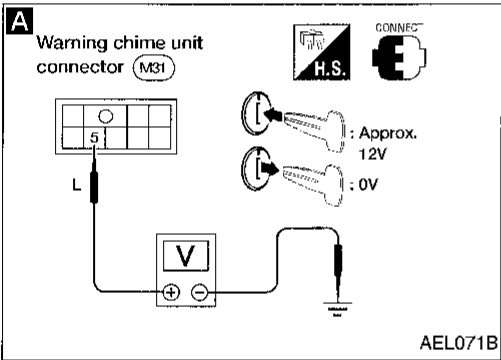

Models without power door locks

A

CHECK KEY SWITCH INPUT SIGNAL.

Check voltage between warning chime unit terminal (5) and ground.

Condition of key switch	Voltage [V]
Key is inserted.	Approx. 12
Key is withdrawn.	0

NG

Check the following.

- Key switch
Refer to "Electrical Components Inspection" (EL-102).
- 10A fuse [No. 24], located in fuse block (J/B)]
- Harness for open or short between key switch and fuse
- Harness for open or short between warning chime unit and key switch

OK

Go to Diagnostic Procedure 4, EL-101.

GI

MA

EM

LC

EC

FE

CL

MT

AT

FA

RA

BR

ST

RS

BT

HA

EL

IDX

WARNING CHIME

Trouble Diagnoses (Cont'd)

DIAGNOSTIC PROCEDURE 3

(Seat belt buckle switch input signal check)

Models with power door locks

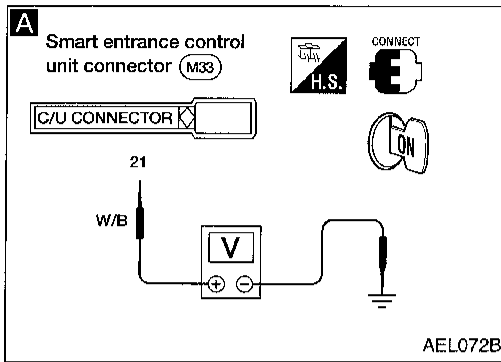

A

CHECK SEAT BELT BUCKLE SWITCH INPUT SIGNAL.

1. Turn ignition switch ON.
2. Check voltage between control unit terminal (21) and ground.

Condition of seat belt buckle switch	Voltage [V]
Fastened	Approx. 12
Unfastened	0

OK

Go to Diagnostic Procedure 4, EL-101.

NG

Check the following.

- Seat belt buckle switch
Refer to "Electrical Components Inspection" (EL-102).
- Seat belt buckle switch ground circuit
- Harness for open or short between control unit and seat belt buckle switch

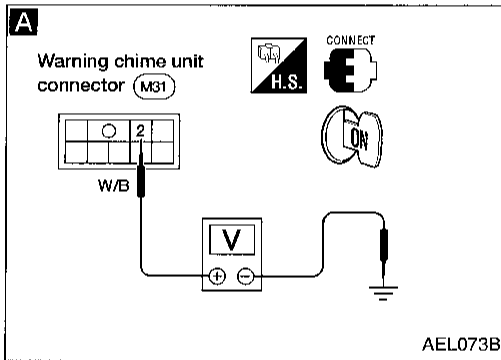

Models without power door locks

A

CHECK SEAT BELT BUCKLE SWITCH INPUT SIGNAL.

1. Turn ignition switch ON.
2. Check voltage between warning chime unit terminal (2) and ground.

Condition of seat belt buckle switch	Voltage [V]
Fastened	Approx. 12
Unfastened	0

OK

Go to Diagnostic Procedure 4, EL-101.

NG

Check the following.

- Seat belt buckle switch
Refer to "Electrical Components Inspection" (EL-102).
- Seat belt buckle switch ground circuit
- Harness for open or short between warning chime unit and seat belt buckle switch

WARNING CHIME

Trouble Diagnoses (Cont'd)

DIAGNOSTIC PROCEDURE 4

(Driver side door switch input signal check)

Models with power door locks

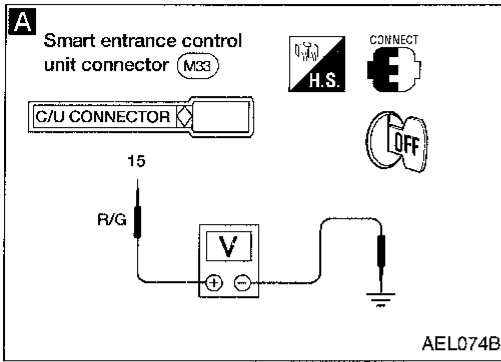

A

CHECK DOOR SWITCH INPUT SIGNAL.
Check voltage between control unit terminal (15) and ground.

Condition of driver's door	Voltage [V]
Driver side door is closed.	Approx. 12
Driver side door is open.	0

NG

Check the following.

- Driver side door switch
Refer to "Electrical Components Inspection" (EL-102).
- Door switch ground condition
- Harness for open or short between control unit and door switch

OK

Replace smart entrance control unit.

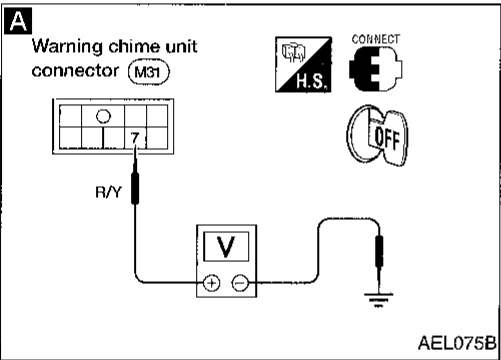

Models without power door locks

A

CHECK DOOR SWITCH INPUT SIGNAL.
Check voltage between control unit terminal (7) and ground.

Condition of driver's door	Voltage [V]
Driver side door is closed.	Approx. 12
Driver side door is open.	0

NG

Check the following.

- Driver side door switch
Refer to "Electrical Components Inspection" (EL-102).
- Door switch ground circuit
- Harness for open or short between control unit and door switch

OK

Replace warning chime unit.

GI

MA

EM

LC

EC

FE

CL

MT

AT

FA

RA

BR

ST

RS

BT

HA

EL

IDX

WARNING CHIME

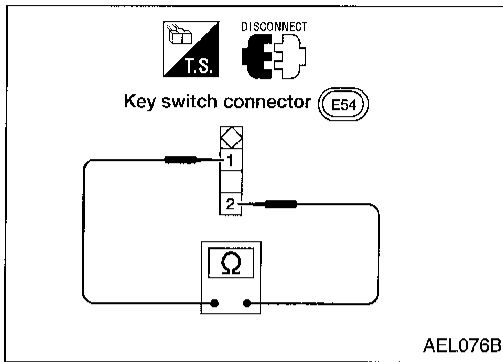

Electrical Components Inspection

KEY SWITCH (insert)

Check continuity between terminals when key is inserted in ignition key cylinder and key is removed from ignition key cylinder.

Terminal No.	Condition	Continuity
① - ②	Key is inserted.	Yes
	Key is removed.	No

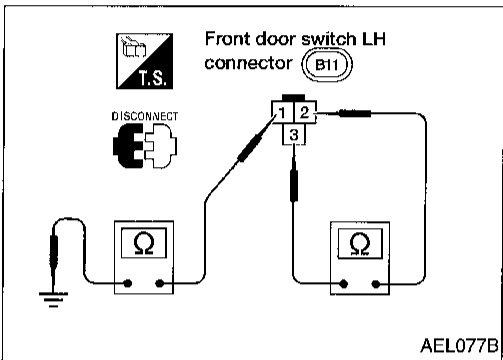

DRIVER SIDE DOOR SWITCH

Check continuity between terminals when door switch is pushed and released.

Terminal No.	Condition	Continuity
① - ground, ② - ③	Door switch is pushed.	No
	Door switch is released.	Yes

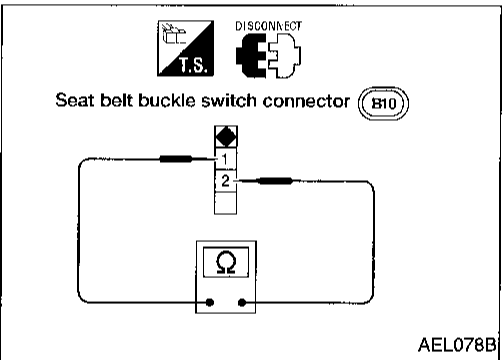

SEAT BELT BUCKLE SWITCH

Check continuity between terminals when seat belt is fastened and unfastened.

Terminal No.	Condition	Continuity
① - ②	Seat belt is fastened.	No
	Seat belt is unfastened.	Yes

WARNING CHIME

NOTES

GI

MA

EM

LC

EC

FE

CL

MT

AT

FA

RA

BR

ST

RS

BT

HA

EL

IDX

System Description

WIPER OPERATION

The wiper switch is controlled by a lever built into the combination switch. There are three wiper switch positions:

- LO speed
- HI speed
- INT (Intermittent).

With the ignition switch in the ACC or ON position, power is supplied:

- through 20A fuse [No. 19, located in the fuse block (J/B)]
- to wiper motor terminal (B) and
- to wiper amplifier terminal (5).

Ground is supplied to wiper amplifier terminal (3) through body grounds (M2) and (M61).

Low and high speed wiper operation

Ground is supplied to wiper switch terminal (17) through body grounds (E10) and (E34).

When the wiper switch is placed in the LO position, ground is supplied:

- through terminal (14) of the wiper switch
- to wiper motor terminal (L).

With power and ground supplied, the wiper motor operates at low speed.

When the wiper switch is placed in the HI position, ground is supplied:

- through terminal (16) of the wiper switch
- to wiper motor terminal (H).

With power and ground supplied, the wiper motor operates at high speed.

Auto stop operation

With wiper switch turned OFF, wiper motor will continue to operate until wiper arms reach windshield base.

When wiper arms are not located at base of windshield with wiper switch OFF, ground is supplied:

- from terminal (14) of the wiper switch
- to wiper motor terminal (L), in order to continue wiper motor operation at low speed.

Ground is also supplied:

- through terminal (13) of the wiper switch
- to wiper amplifier terminal (2)
- through terminal (7) of the wiper amplifier
- to wiper motor terminal (P)
- through terminal (E) of the wiper motor, and
- through body grounds (M2) and (M61).

When wiper arms reach base of windshield, wiper motor terminals (P) and (B) are connected instead of terminals (P) and (E). Wiper motor will then stop wiper arms at the PARK position.

Intermittent operation

The wiper motor operates the wiper arms one time at low speed at a set interval of approximately 3 to 13 seconds. This feature is controlled by the wiper amplifier.

When the wiper switch is placed in the INT position, ground is supplied:

- to wiper amplifier terminal (1)
- from wiper switch terminal (15)
- through body grounds (E10) and (E34)
- to wiper motor terminal (L)
- through the wiper switch terminal (14)
- to wiper switch terminal (13)
- through wiper amplifier terminal (2)
- to wiper amplifier terminal (3)
- through body grounds (M2) and (M61).

The desired interval time is input:

- to wiper amplifier terminal (8)
- from wiper switch terminal (19)
- to wiper switch terminal (20)
- through body grounds (E10) and (E34).

The wiper motor operates at low speed at the desired time interval.

FRONT WIPER AND WASHER

System Description (Cont'd)

WASHER OPERATION

With the ignition switch in the ACC or ON position, power is supplied:

- through 20A fuse [No. 19, located in the fuse block (J/B)]
- to washer motor terminal ②.

When the lever is pulled to the WASH position, ground is supplied:

- to washer motor terminal ①, and
- to wiper amplifier terminal ⑥
- from terminal ⑱ of the wiper switch
- through terminal ⑰ of the wiper switch, and
- through body grounds E10 and E34 .

With power and ground supplied, the washer motor operates.

When the lever is pulled to the WASH position for one second or more, the wiper motor operates at low speed for approximately 3 seconds to clean windshield. This feature is controlled by the wiper amplifier in the same manner as the intermittent operation.

GI

MA

EM

LC

EC

FE

CL

MT

AT

FA

RA

BR

ST

RS

BT

HA

EL

IDX

FRONT WIPER AND WASHER

Wiring Diagram — WIPER — (Cont'd)

EL-WIPER-02

GI
MA
EM
LC
EC
FE
CL
MT
AT
FA
RA
BR
ST
RS
BT
HA
EL
IDX

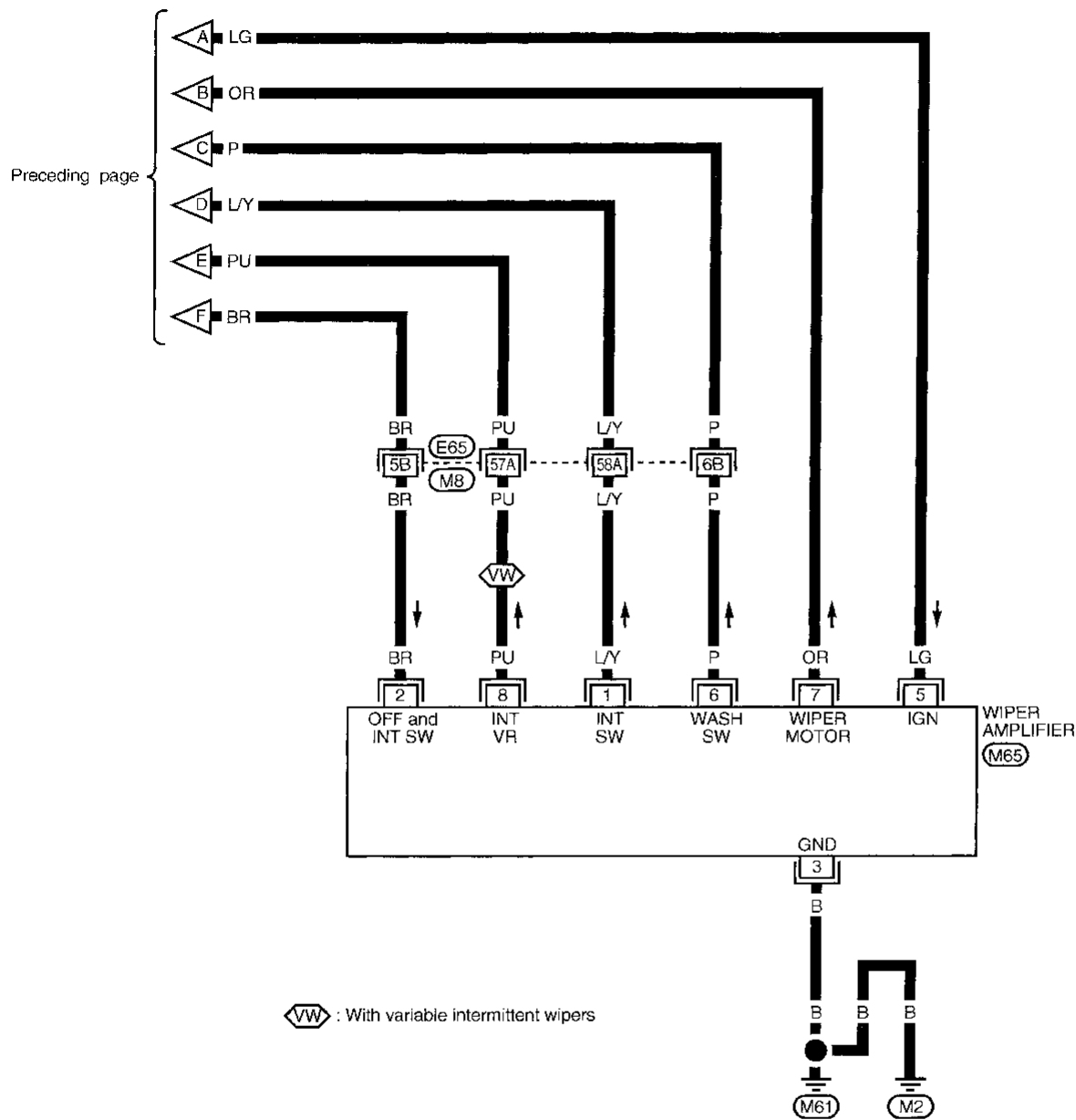

Refer to last page (Foldout page).

(M8), (E65)

	3	2	1	(M65) W
8	7	6	5	

FRONT WIPER AND WASHER

Trouble Diagnoses

DIAGNOSTIC PROCEDURE 1

SYMPTOM: Intermittent wiper does not operate.

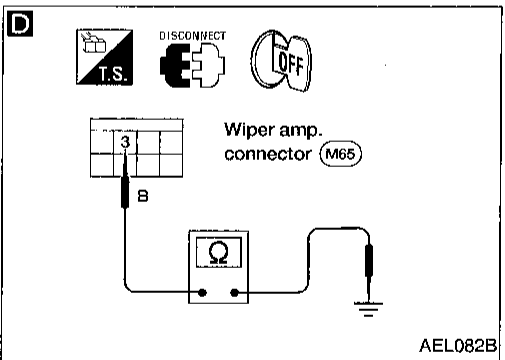
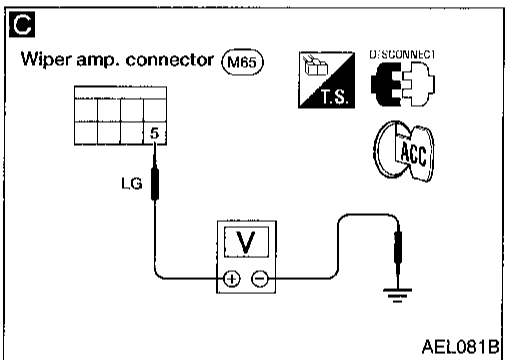
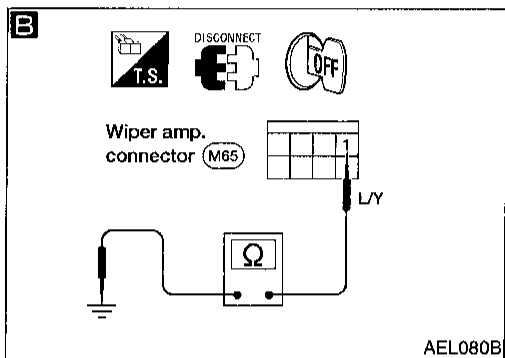
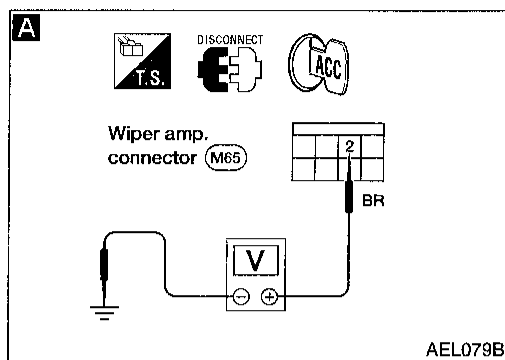

Check whether wiper operates with the wiper switch at LO position.

NG

Check the following.

- 20A fuse [No. 19], located in fuse block (J/B)]
- Wiper motor
- Wiper switch
- Harness for open or short

OK

A

1. Turn front wiper switch to OFF.
2. Disconnect wiper amp. connector.
3. Check voltage between wiper amp. terminal ② and ground.

Battery voltage should exist.

NG

Check the following.

- Wiper switch
- Harness for open or short between wiper amp. terminal ② and wiper switch terminal ⑬

OK

B

CHECK INTERMITTENT SWITCH INPUT SIGNAL.

Check harness continuity between wiper amp. terminal ① and ground.

NG

Check the following.

- Wiper switch
- Harness for open or short between wiper amp. terminal ① and wiper switch terminal ⑮
- Ground circuit for front wiper switch terminal ⑰

OK

Condition of wiper switch	Continuity
OFF	No
INT	Yes

C

CHECK WIPER AMP. POWER SUPPLY CIRCUIT.

Check voltage between wiper amp. terminal ⑤ and ground while ignition switch is in ACC.

Battery voltage should exist.

NG

Check the following.

- Harness for open or short between wiper amp. and fuse

OK

D

CHECK WIPER AMP. GROUND CIRCUIT.

Check harness continuity between wiper amp. terminal ③ and body ground.

Continuity should exist.

NG

Repair harness or connector.

OK

Replace wiper amp.

FRONT WIPER AND WASHER

Trouble Diagnoses (Cont'd)

DIAGNOSTIC PROCEDURE 2

SYMPTOM: Intermittent time of wiper cannot be adjusted.

GI

MA

EM

LC

EC

FE

CL

MT

AT

FA

RA

BR

ST

RS

BT

HA

EL

IDX

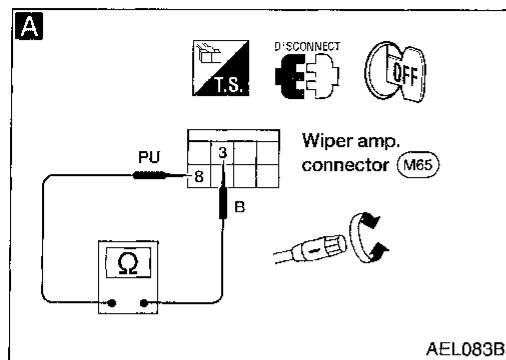

A

CHECK INTERMITTENT WIPER VOLUME INPUT SIGNAL.

1. Disconnect wiper amp. connector.
2. Measure resistance between wiper amp. terminals (8) and (3) while turning intermittent wiper volume.

Position of wiper knob	Resistance [Ω]
S	0
L	Approx. 1 k

NG

Check the following.

- Harness for open or short between wiper amp. terminal (8) and wiper switch terminal (19)
- Ground circuit for front wiper switch terminal (20)

OK

Check intermittent wiper volume.

NG

Replace wiper switch.

DIAGNOSTIC PROCEDURE 3

SYMPTOM: Wiper and washer activate individually but not in combination.

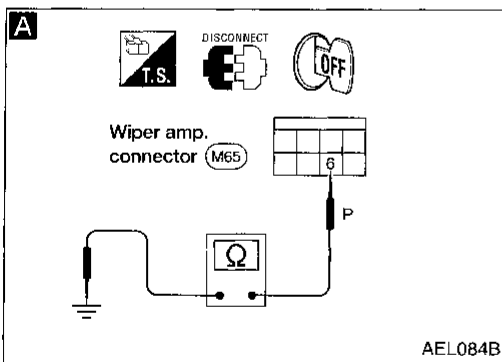

A

CHECK WASHER SWITCH INPUT SIGNAL.

1. Turn ignition switch OFF.
2. Disconnect wiper amp. connector.
3. Check harness continuity between wiper amp. terminal (6) and ground.

Condition of washer switch	Continuity
OFF	No
ON	Yes

OK

Go to DIAGNOSTIC PROCEDURE 1.

NG

Replace wiper amp.

FRONT WIPER AND WASHER

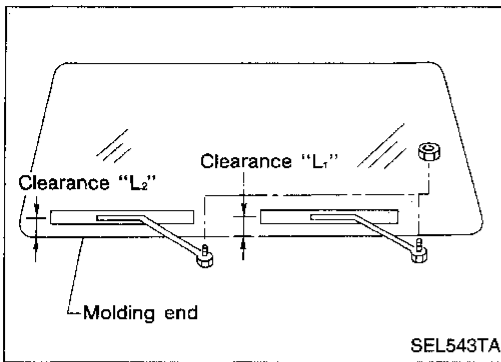

Removal and Installation

WIPER ARMS

1. Prior to wiper arm installation, turn on wiper switch to operate wiper motor and then turn it OFF (Auto Stop).
 2. Lift the blade up and then set it down onto glass surface to set the blade center to clearance "L₁" & "L₂" immediately before tightening nut.
 3. Eject washer fluid. Turn on wiper switch to operate wiper motor and then turn it OFF.
 4. Ensure that wiper blades stop within clearance "L₁" & "L₂".
 - Clearance "L₁": 45 mm (1.77 in)
 - Clearance "L₂": 38 mm (1.50 in)
- Tighten wiper arm nuts to specified torque.
Front wiper: 17 - 23 N·m (1.7 - 2.3 kg·m, 12 - 17 ft·lb)

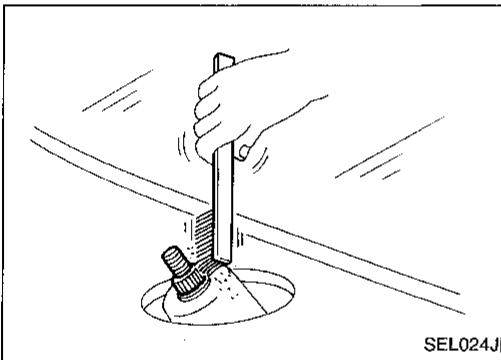

- Before reinstalling wiper arm, clean up the pivot area as illustrated. This will reduce possibility of wiper arm looseness.

WIPER LINKAGE

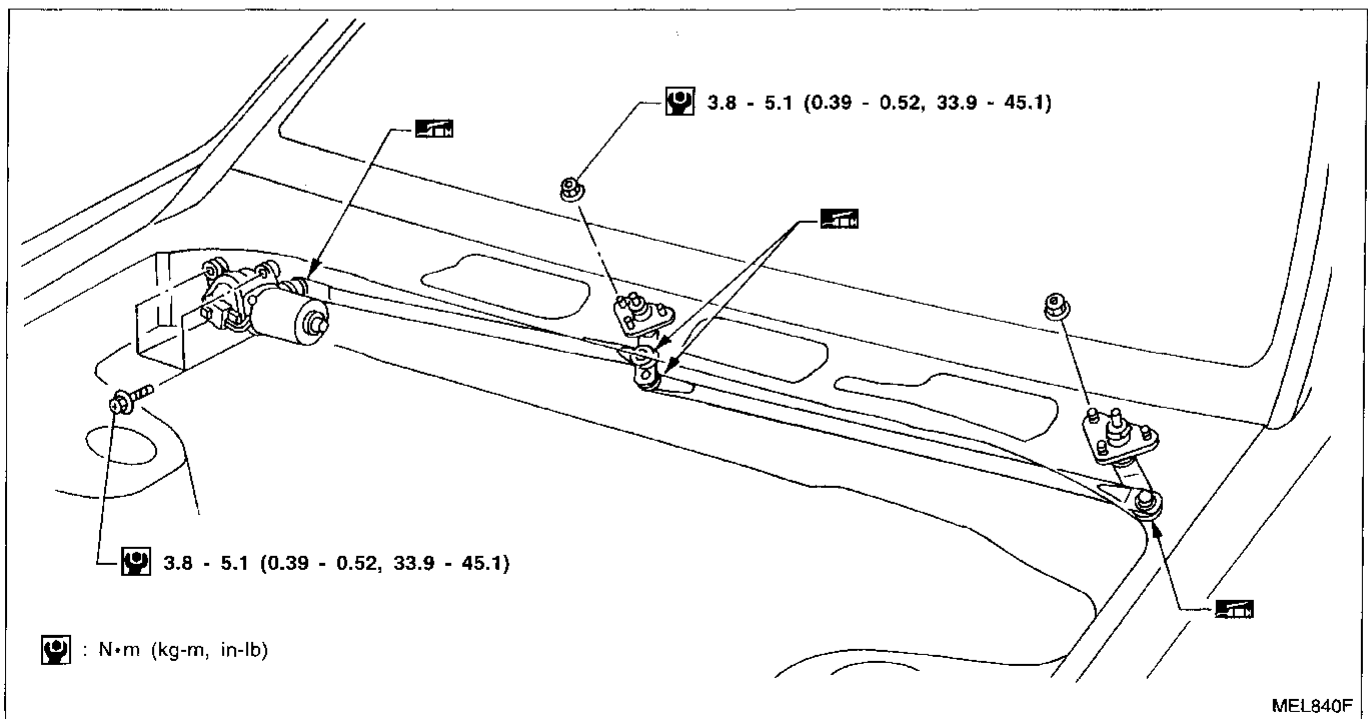

FRONT WIPER AND WASHER

Removal and Installation (Cont'd)

Removal

1. Remove 4 bolts that secure wiper motor.
2. Detach wiper motor from wiper linkage at ball joint.
3. Remove wiper linkage.

Be careful not to break ball joint rubber boot.

Installation

- Grease ball joint portion before installation.
1. Installation is the reverse order of removal.

GI

MA

EM

LG

EC

FE

CL

MT

AT

FA

RA

BR

ST

RS

BT

HA

EL

IDX

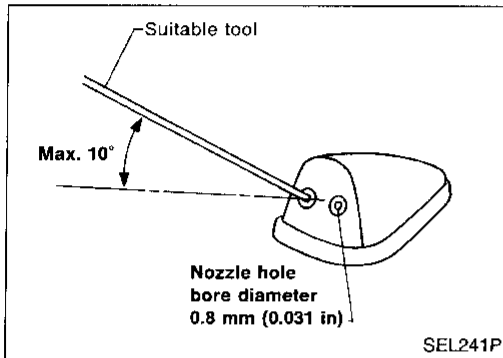

Washer Nozzle Adjustment

- Adjust washer nozzle with suitable tool as shown in the figure at left.

Adjustable range: $\pm 10^\circ$

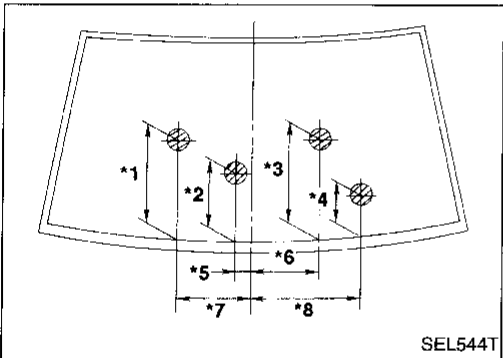

Unit: mm (in)

*1	350 (13.78)	*5	135 (5.31)
*2	190 (7.48)	*6	230 (9.06)
*3	320 (12.60)	*7	275 (10.83)
*4	135 (5.31)	*8	440 (17.32)

*: The diameters of these circles are less than 80 mm (3.15 in).

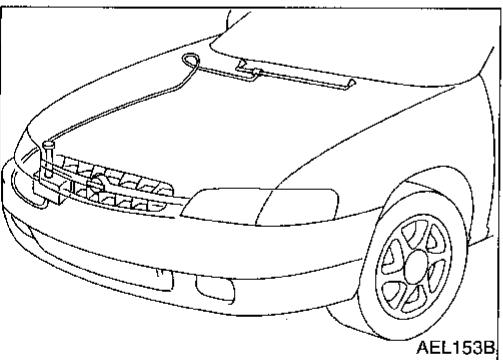

Washer Tube Layout

HORN

Wiring Diagram — HORN —

EL-HORN-01

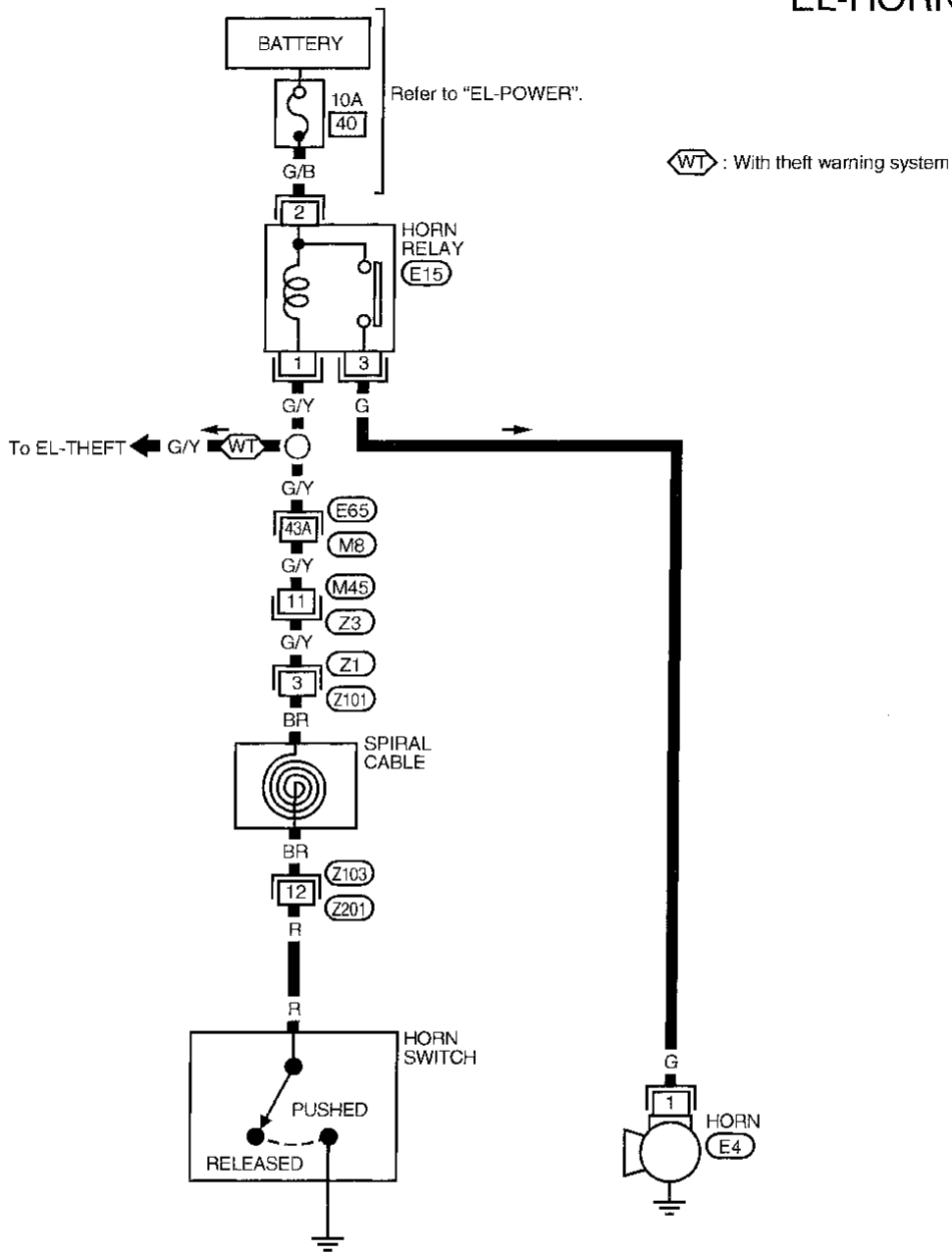

Refer to last page (Foldout page).

(M8) (E65)

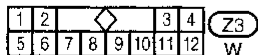
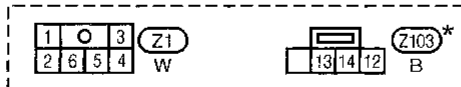
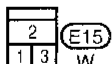

* : This connector is not shown in "HARNES LAYOUT" of EL section.

CIGARETTE LIGHTER

Wiring Diagram — CIGAR —

EL-CIGAR-01

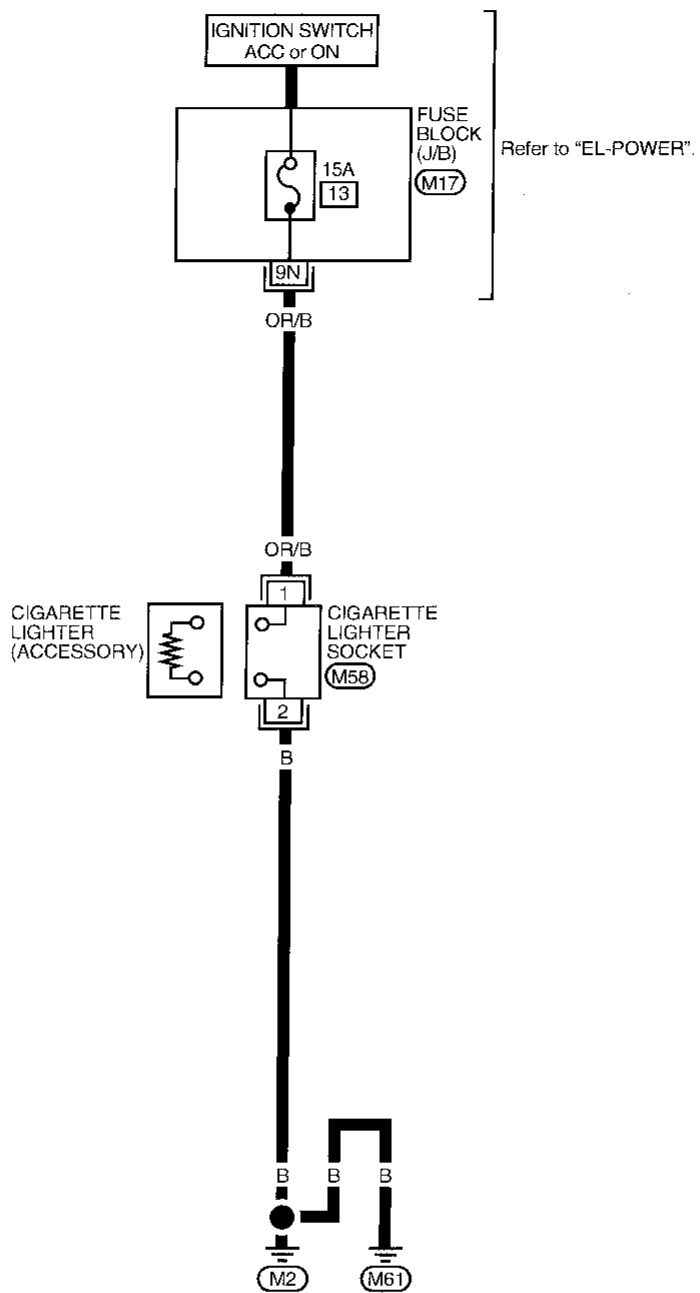

- GI
- MA
- EM
- LC
- EC
- FE
- CL
- MT
- AT
- FA
- RA
- BR
- ST
- RS
- BT
- HA
- EL**
- IDX

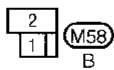

REAR WINDOW DEFOGGER

Component Parts and Harness Connector Location

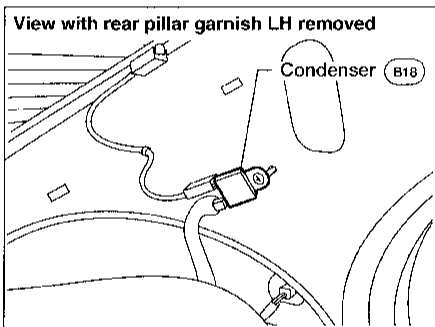
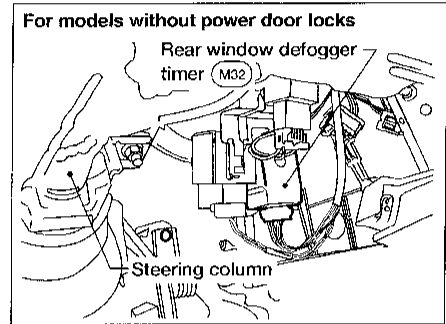
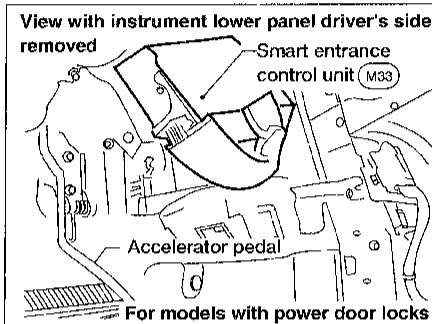
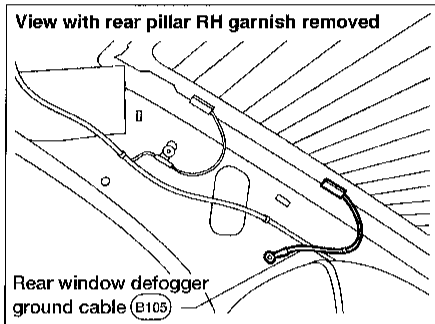
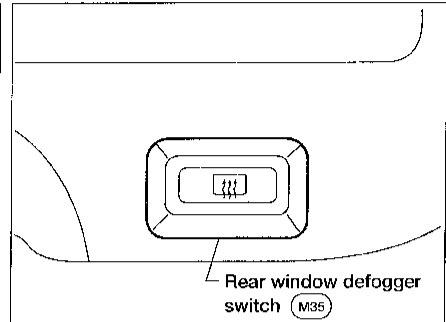
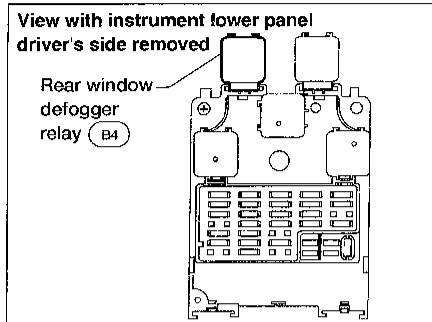
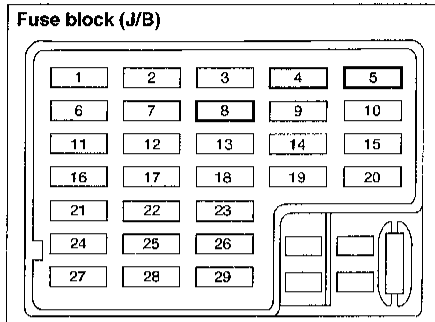

System Description

MODELS WITH POWER DOOR LOCKS

The rear window defogger system is controlled by the smart entrance control unit. The rear window defogger operates for approximately 15 minutes.

Power is supplied at all times:

- to rear window defogger relay terminal ③
- through 20A fuse [No. ⑤], located in the fuse block (J/B) and
- to rear window defogger relay terminal ⑥
- through 20A fuse [No. ④], located in the fuse block (J/B).

With the ignition switch in the ON or START position, power is supplied:

- to rear window defogger relay terminal ① and
- to smart entrance control unit terminal ⑪
- through 10A fuse [No. ⑧], located in the fuse block (J/B).

Ground is supplied to terminal ⑩ of the smart entrance control unit through body grounds M2 and M61.

Ground is also supplied to terminal ② of the rear window defogger switch through body grounds M2 and M61.

When the rear window defogger switch is turned ON, ground is supplied:

- through terminal ① of the rear window defogger switch
- to smart entrance control unit terminal ⑳.

Terminal ⑳ of the smart entrance control unit then supplies ground to the rear window defogger relay terminal ②.

With power and ground supplied, the rear window defogger relay is energized.

Power is supplied:

- through terminals ⑤ and ⑦ of the rear window defogger relay
- to condenser terminal ⊕
- through condenser terminal ⊖
- to the rear window defogger terminal ⊕.

Ground is supplied to terminal ⊖ of the rear window defogger through body ground B105.

With power and ground supplied, the rear window defogger filaments heat and defog the rear window.

When the system is activated, the rear window defogger indicator illuminates in the rear window defogger switch.

Power is supplied:

- to terminal ③ of the rear window defogger switch
- from terminals ⑤ and ⑦ of the rear window defogger relay.

Terminal ④ of the rear window defogger switch is grounded through body grounds M2 and M61.

GI

MA

EM

LC

EC

FE

CL

MT

AT

FA

RA

BR

ST

RS

BT

HA

EL

IDX

REAR WINDOW DEFOGGER

System Description (Cont'd)

MODELS WITHOUT POWER DOOR LOCKS

If not equipped with power door locks, the rear defogger system is controlled by the rear window defogger timer. The rear window defogger operates for approximately 15 minutes.

Power is supplied at all times:

- through 20A fuse (No. 4), located in the fuse block [J/B])
- to rear window defogger relay terminal 6 and
- through 20A fuse (No. 5), located in the fuse block [J/B])
- to rear window defogger relay terminal 3.

With the ignition switch in the ON or START position, power is supplied:

- through 10A fuse (No. 8), located in the fuse block [J/B])
- to rear window defogger relay terminal 1 and
- to rear window defogger timer terminal 1.

Ground is supplied to terminal 4 of the rear window defogger timer through body grounds M2 and M61.

Ground is also supplied to terminal 2 of the rear window defogger switch through body grounds M2 and M61.

When the rear window defogger switch is turned ON, ground is supplied:

- through terminal 1 of the rear window defogger switch
- to rear window defogger timer terminal 3.

Terminal 2 of the rear window defogger timer then supplies ground to the rear window defogger relay terminal 2.

With power and ground supplied, the rear window defogger relay is energized.

Power is supplied:

- through terminals 5 and 7 of the rear window defogger relay
- to condenser terminal +
- through condenser terminal -
- to rear window defogger terminal +.

Ground is supplied to terminal - of rear window defogger through body ground B105.

With power and ground supplied, the rear window defogger filaments heat and defog the rear window.

When the system is activated, the rear window defogger indicator illuminates in the rear window defogger switch.

Power is supplied:

- to terminal 3 of the rear window defogger switch
- from terminals 5 and 7 of the rear window defogger relay.

Terminal 4 of the rear window defogger switch is grounded through body grounds M2 and M61.

REAR WINDOW DEFOGGER

Wiring Diagram — DEF —

MODELS WITH POWER DOOR LOCKS

EL-DEF-01

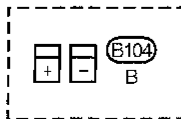
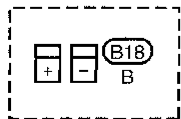
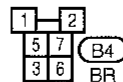
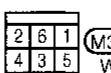
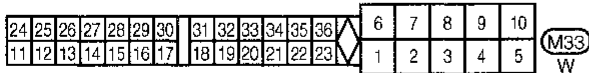
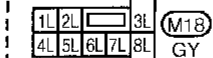
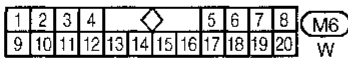
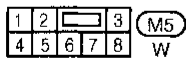
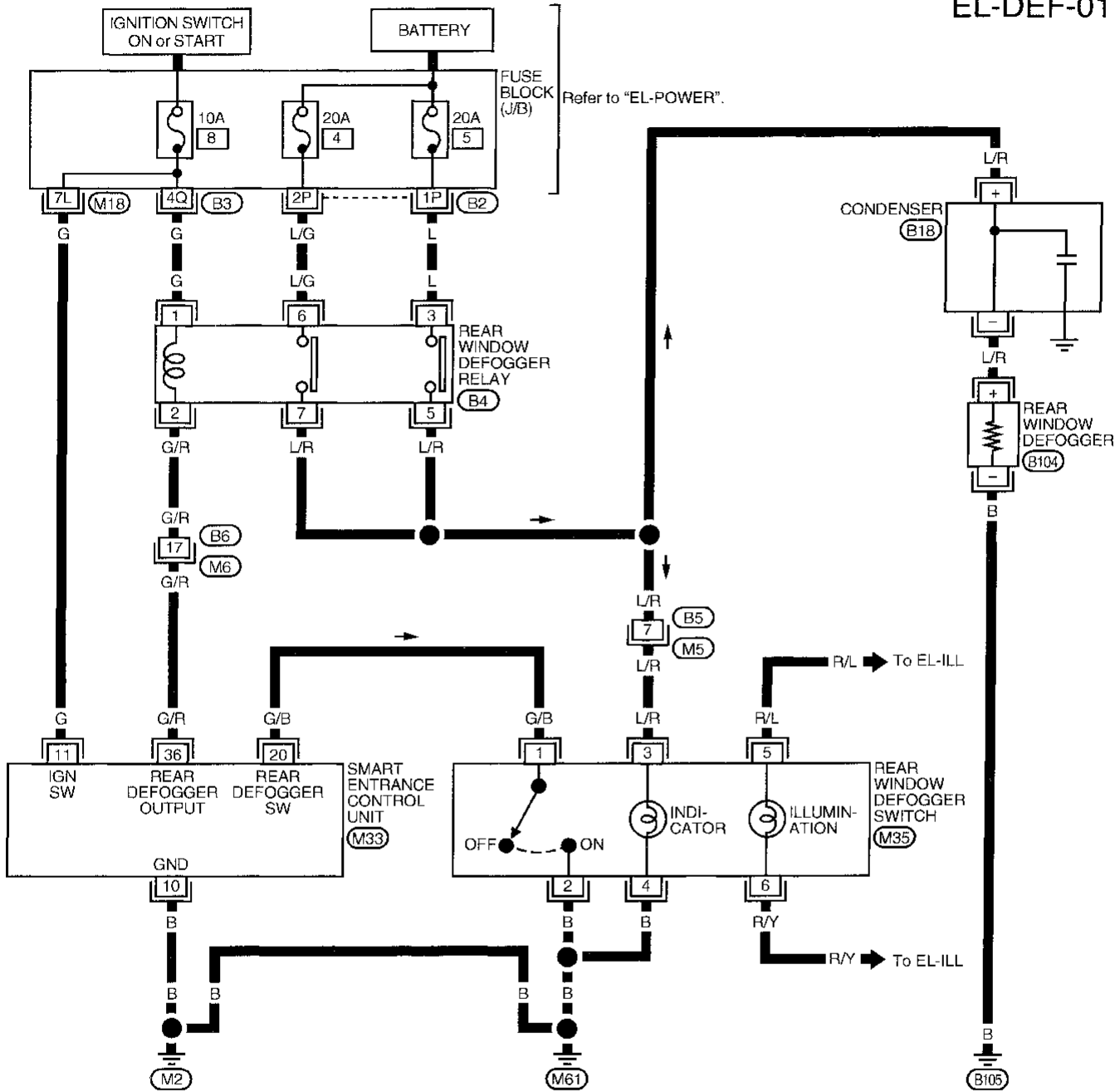

AEL969A

REAR WINDOW DEFOGGER

Wiring Diagram — DEF — (Cont'd)

MODELS WITHOUT POWER DOOR LOCKS

EL-DEF-02

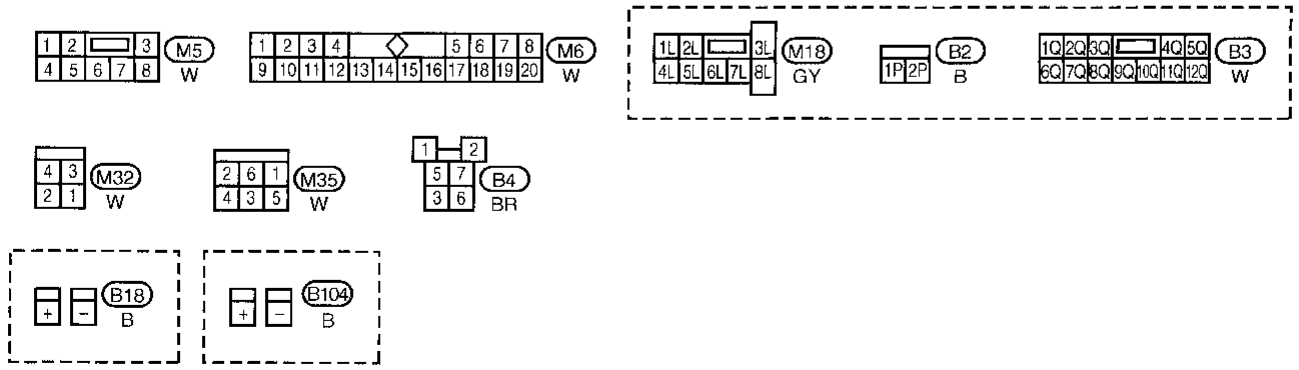
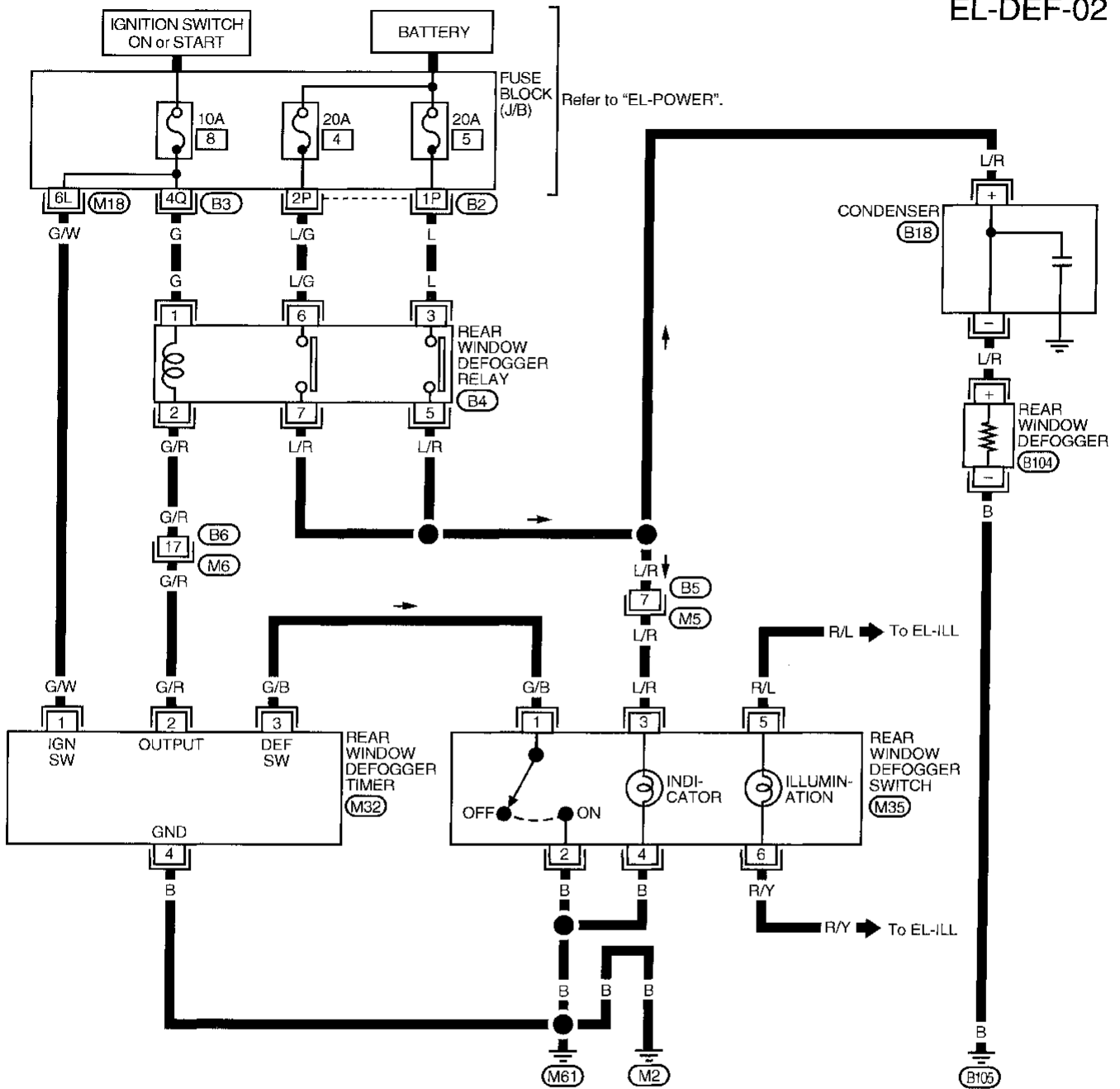

REAR WINDOW DEFOGGER

Trouble Diagnoses (For models with power door locks)

DIAGNOSTIC PROCEDURE

SYMPTOM: Rear window defogger does not activate, or does not go off after activating.

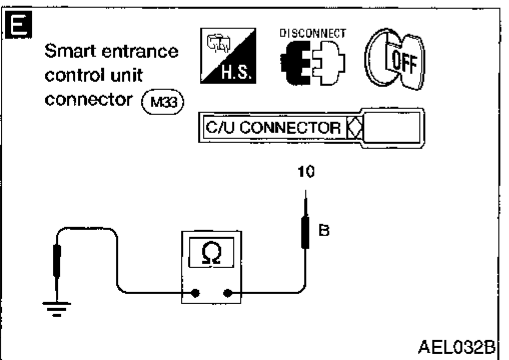
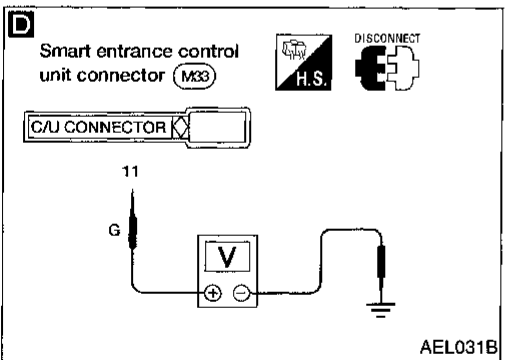
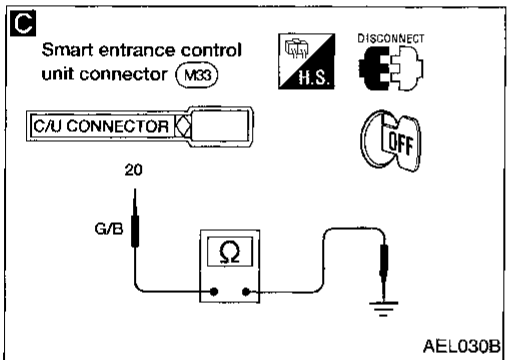
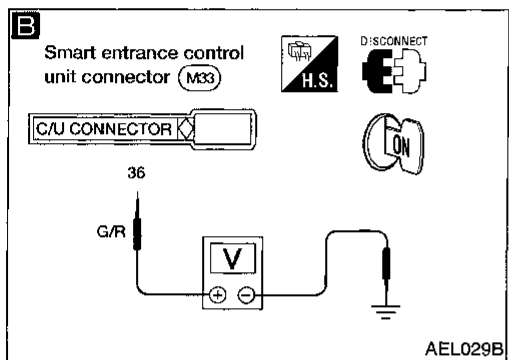
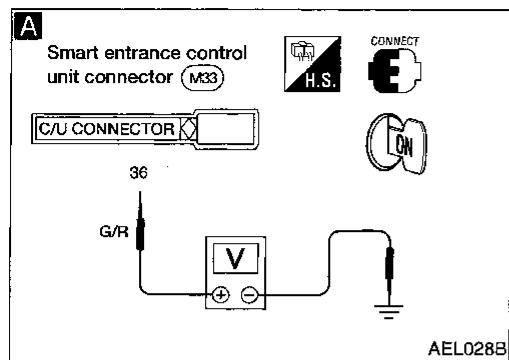

A CHECK REAR WINDOW DEFOGGER OUTPUT SIGNAL.

1. Turn ignition switch to ON position.
2. Check voltage between control unit harness terminal (36) and ground.

Condition	Voltage [V]
Rear window defogger switch is OFF.	Approx. 12
Rear window defogger switch is ON.	0

- OK →
- Check the following.
- Rear window defogger relay (Refer to EL-121.)
 - Rear window defogger circuit
 - Rear window defogger filament (Refer to EL-121.)

- NG ↓
- B**
1. Disconnect control unit connector.
 2. Turn ignition switch to ON position.
 3. Check voltage between control unit terminal (36) and ground.
- Battery voltage should exist.**

- NG →
- Check the following.
- 10A fuse [No. 8], located in the fuse block (J/B)
 - Rear window defogger relay
 - Harness for open or short between fuse and rear window defogger relay
 - Harness for open or short between rear window defogger relay and control unit

- OK ↓
- C**
- #### CHECK REAR WINDOW DEFOGGER SWITCH INPUT SIGNAL.
- Check continuity between control unit terminal (20) and ground.

Condition of defogger switch	Continuity
Rear window defogger switch is pushed.	Yes
Rear window defogger switch is released.	No

- NG →
- Check the following.
- Rear window defogger switch (Refer to EL-121.)
 - Harness for open or short between control unit and rear window defogger switch
 - Rear window defogger switch ground circuit

- OK ↓
- D**
- #### CHECK IGNITION INPUT SIGNAL.
- Check voltage between control unit terminal (11) and ground.

Condition	Voltage [V]
Ignition switch is ON.	Approx. 12
Ignition switch is OFF.	0

- NG →
- Check the following.
- 10A fuse [No. 8], located in the fuse block (J/B)
 - Harness for open or short between control unit and fuse

- OK ↓
- E**
- #### CHECK CONTROL UNIT GROUND CIRCUIT.
- Check continuity between control unit terminal (10) and ground.
- Continuity should exist.**

- NG →
- Repair harness or connectors.

OK ↓

Replace control unit.

GI
MA
EM
LC
EC
FE
CL
MT
AT
FA
RA
BR
ST
RS
BT
HA
EL
IDX

REAR WINDOW DEFOGGER

Trouble Diagnoses (For models without power door locks)

DIAGNOSTIC PROCEDURE

SYMPTOM: Rear window defogger does not activate, or does not go off after activating.

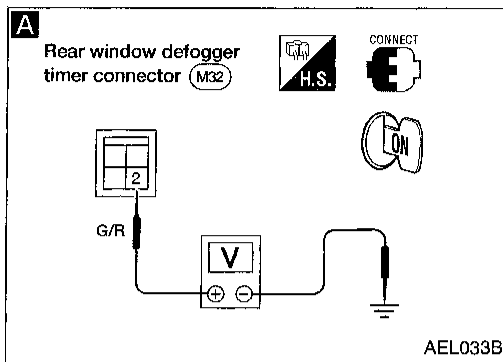

A

CHECK REAR WINDOW DEFOGGER OUTPUT SIGNAL.
1. Turn ignition switch to ON position.
2. Check voltage between rear window defogger timer terminal ② and ground.

Condition	Voltage [V]
Rear window defogger switch is OFF.	Approx. 12
Rear window defogger switch is ON.	0

- OK → Check the following.
- Rear window defogger relay (Refer to EL-121.)
 - Rear window defogger circuit
 - Rear window defogger filament (Refer to EL-121.)

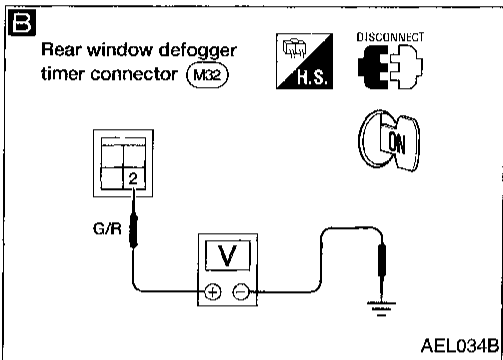

NG ↓

B

1. Disconnect rear window defogger timer connector.
2. Turn ignition switch to ON position.
3. Check voltage between rear window defogger timer terminal ② and ground. **Battery voltage should exist.**

- NG → Check the following.
- 10A fuse [No. 8], located in the fuse block (J/B)
 - Rear window defogger relay
 - Harness for open or short between fuse and rear window defogger relay
 - Harness for open or short between rear window defogger relay and rear window defogger timer

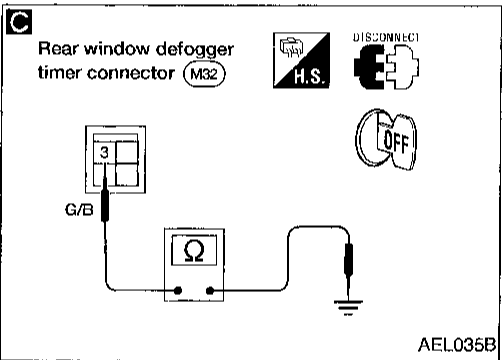

OK ↓

C

CHECK REAR WINDOW DEFOGGER SWITCH INPUT SIGNAL.
Check continuity between rear window defogger timer terminal ③ and ground.

Condition of defogger switch	Continuity
Rear window defogger switch is pushed.	Yes
Rear window defogger switch is released.	No

- NG → Check the following.
- Rear window defogger switch (Refer to EL-121.)
 - Harness for open or short between rear window defogger timer and rear window defogger switch
 - Rear window defogger switch ground circuit

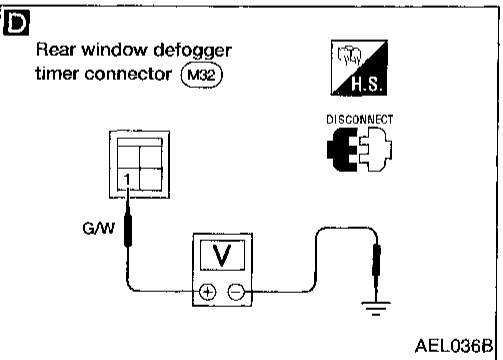

OK ↓

D

CHECK IGNITION INPUT SIGNAL.
Check voltage between rear window defogger timer terminal ① and ground.

Condition	Voltage [V]
Ignition switch is ON.	Approx. 12
Ignition switch is OFF.	0

- NG → Check the following.
- 10A fuse [No. 8], located in the fuse block (J/B)
 - Harness for open or short between rear window defogger timer and fuse

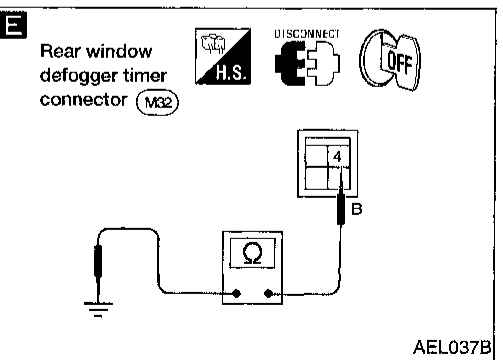

OK ↓

E

CHECK REAR WINDOW DEFOGGER TIMER GROUND CIRCUIT.
Check continuity between rear window defogger timer terminal ④ and ground. **Continuity should exist.**

OK ↓

Replace rear window defogger timer.

- NG → Repair harness or connectors.

REAR WINDOW DEFOGGER

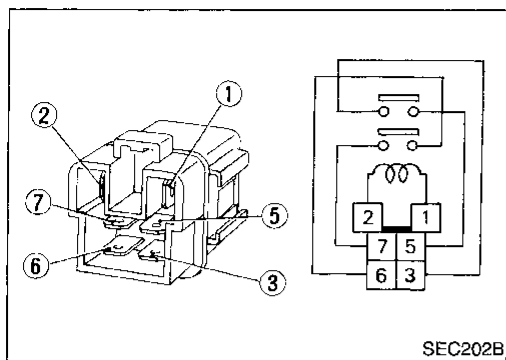

SEC202B

Electrical Components Inspection

REAR WINDOW DEFOGGER RELAY

Check continuity between terminals ③ and ⑤, ⑥ and ⑦.

Condition	Continuity
12V direct current supply between terminals ① and ②	Yes
No current supply	No

GI

MA

EM

LC

EC

FE

CL

MT

AT

FA

RA

BR

ST

RS

BT

HA

EL

IDX

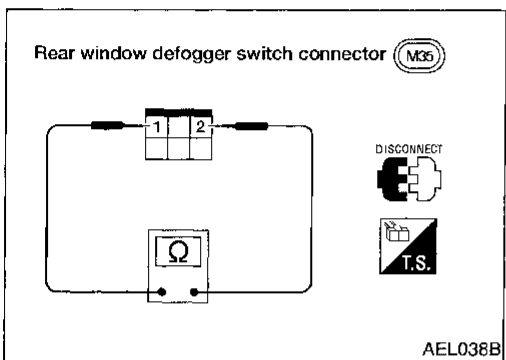

AEL038B

REAR WINDOW DEFOGGER SWITCH

Check continuity between terminals when rear window defogger switch is pushed and released.

Terminals	Condition	Continuity
① - ②	Rear window defogger switch is pushed.	Yes
	Rear window defogger switch is released.	No

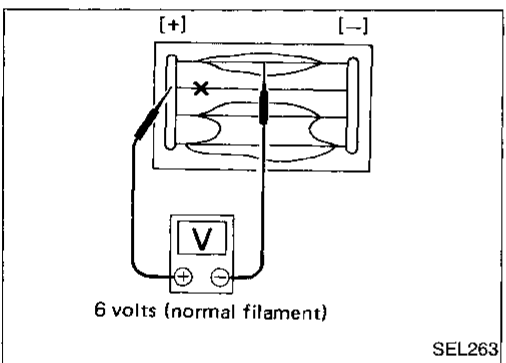

SEL263

Filament Check

1. Attach probe circuit tester (in volt range) to middle portion of each filament.

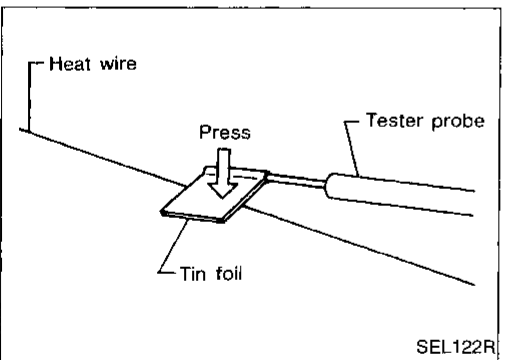

SEL122R

- When measuring voltage, wrap tin foil around the top of the negative probe. Then press the foil against the wire with your finger.

REAR WINDOW DEFOGGER

Filament Check (Cont'd)

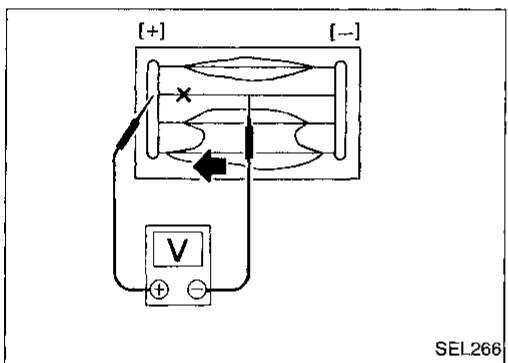
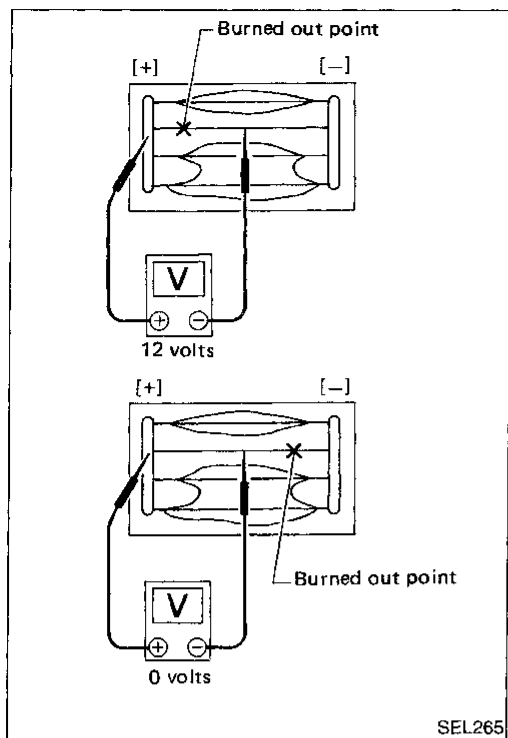

2. If a filament is burned out, circuit tester registers 0 or 12 volts.

3. To locate burned out point, move probe to left and right along filament. Test needle will swing abruptly when probe passes the point.

Filament Repair

REPAIR EQUIPMENT

1. Conductive silver composition (Dupont No. 4817 or equivalent)
2. Ruler 30 cm (11.8 in) long
3. Drawing pen
4. Heat gun
5. Alcohol
6. Cloth

REPAIRING PROCEDURE

1. Wipe broken heat wire and its surrounding area clean with a cloth dampened in alcohol.
2. Apply a small amount of conductive silver composition to tip of drawing pen.

Shake silver composition container before use.

3. Place ruler on glass along broken line. Deposit conductive silver composition on break with drawing pen. Slightly overlap existing heat wire on both sides [preferably 5 mm (0.20 in)] of the break.

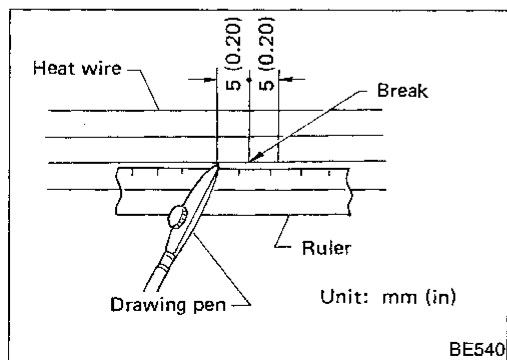

REAR WINDOW DEFOGGER

Filament Repair (Cont'd)

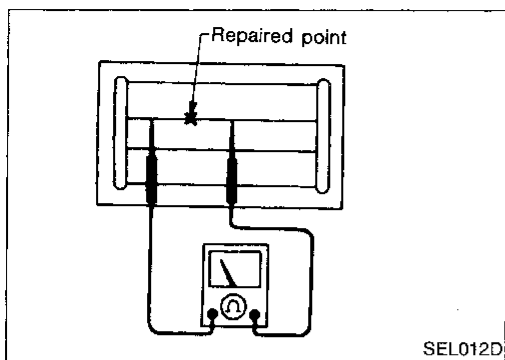

4. After repair has been completed, check repaired wire for continuity. This check should be conducted 10 minutes after silver composition is deposited.

Do not touch repaired area while test is being conducted.

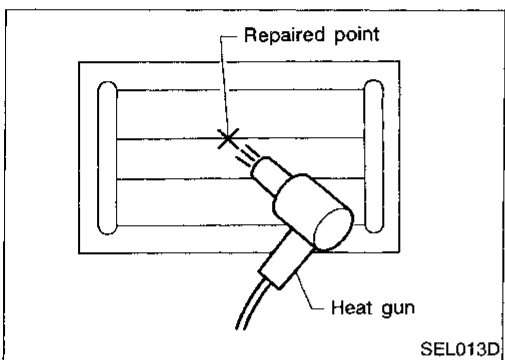

5. Apply a constant stream of hot air directly to the repaired area for approximately 20 minutes with a heat gun. A minimum distance of 3 cm (1.2 in) should be kept between repaired area and hot air outlet. If a heat gun is not available, let the repaired area dry for 24 hours.

GI

MA

EM

LC

EC

FE

CL

MT

AT

FA

RA

BR

ST

RS

BT

HA

EL

IDX

System Description

Refer to Owner's Manual for audio system operating instructions.

Power is supplied at all times:

- through 10A fuse (No. 35, located in the fuse and fusible link box)
- to radio terminal ⑥.

With the ignition switch in the ACC or ON position, power is supplied:

- through 10A fuse [No. 10, located in the fuse block (J/B)]
- to audio terminal ⑩.

Ground is supplied through the case of the audio.

When the audio power knob is pushed to the ON position, audio signals are supplied:

- through audio terminals ①, ②, ③, ④, ⑬, ⑭, ⑮, and ⑯
- to the front and rear speakers or tweeters.

NOTES

GI

MA

EM

LC

EC

FE

CL

MT

AT

FA

RA

BR

ST

RS

BT

HA

EL

IDX

AUDIO

Wiring Diagram — AUDIO —

MODELS WITH PREMIUM AUDIO SYSTEM

EL-AUDIO-01

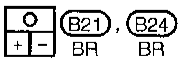
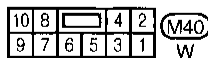
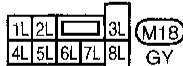
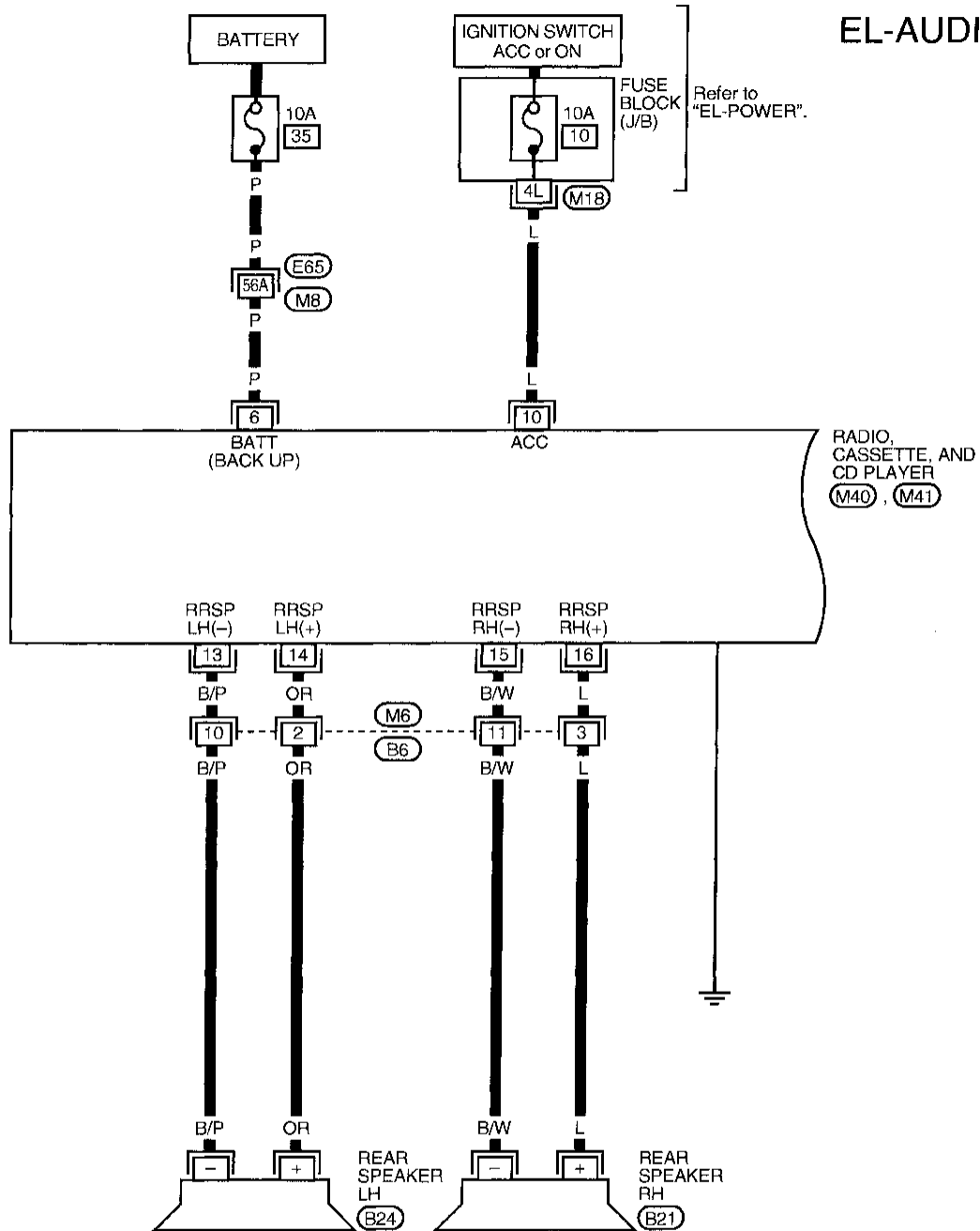

Refer to last page (Foldout page).

M8, E65

AUDIO

Wiring Diagram — AUDIO — (Cont'd)

EL-AUDIO-02

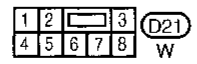
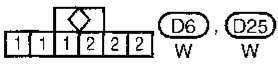
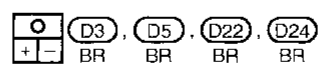
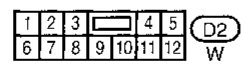
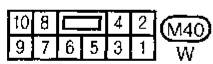
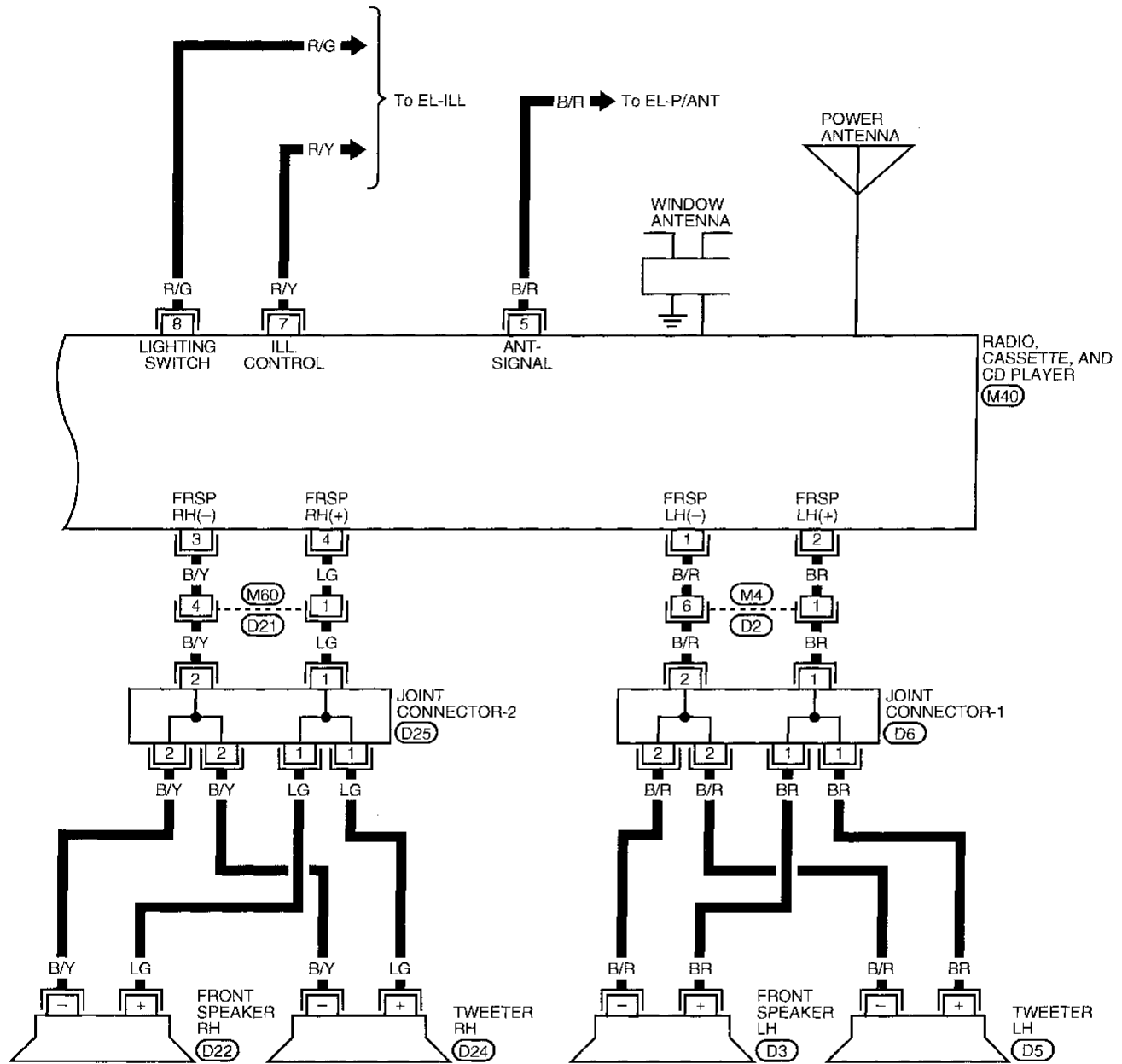

GI
 MA
 EM
 LC
 EC
 FE
 CL
 MT
 AT
 FA
 RA
 BR
 ST
 RS
 BT
 HA
EL
 IX

AUDIO

Wiring Diagram — AUDIO — (Cont'd)

MODELS WITH BASE AUDIO SYSTEM

EL-AUDIO-03

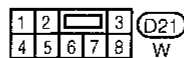
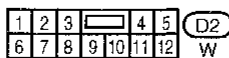
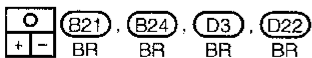
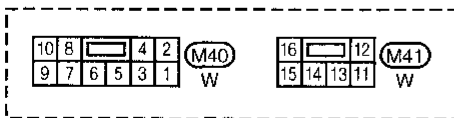
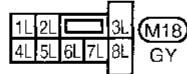
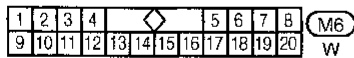
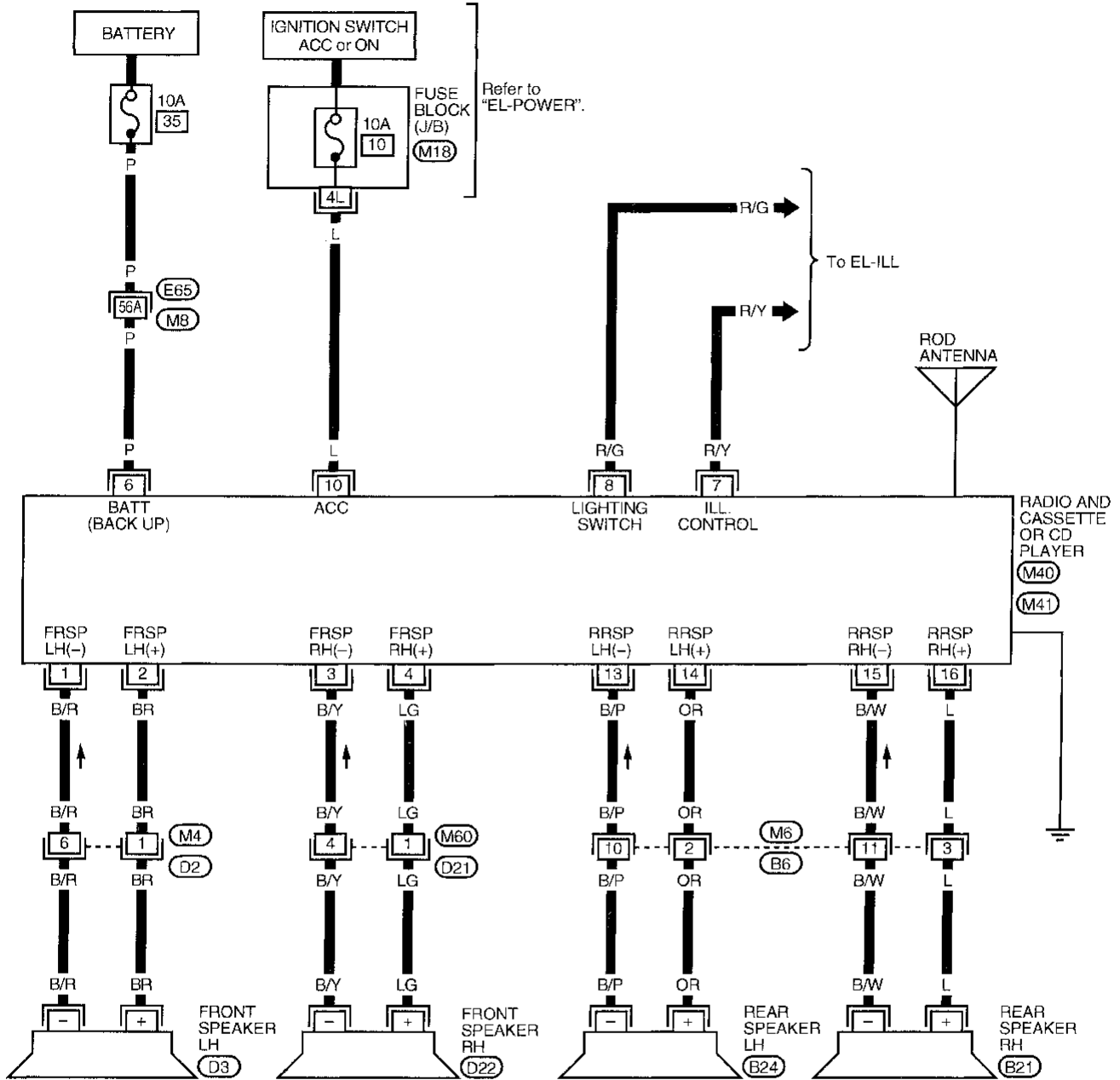

Refer to last page (Foldout page).

(M8), (E65)

AUDIO

Trouble Diagnoses

RADIO

Symptom	Possible causes	Repair order
Radio inoperative (no digital display and no sound from speakers).	<ol style="list-style-type: none"> 10A fuse Poor radio case ground Radio 	<ol style="list-style-type: none"> Check 10A fuse [No. 10], located in fuse block (J/B)]. Turn ignition switch ON and verify that battery positive voltage is present at terminal 10 of radio. Check radio case ground. Remove radio for repair.
Radio controls are operational, but no sound is heard from any speaker.	<ol style="list-style-type: none"> Radio output Radio 	<ol style="list-style-type: none"> Check radio/amp. output voltage. Remove radio/amp. for repair.
Radio presets are lost when ignition switch is turned OFF.	<ol style="list-style-type: none"> 10A fuse Radio 	<ol style="list-style-type: none"> Check 10A fuse (No. 35), located in fuse and fusible link box) and verify that battery positive voltage is present at terminal 6 of radio. Remove radio for repair.
Individual speaker is noisy or inoperative.	<ol style="list-style-type: none"> Speaker Radio output Speaker circuit Radio 	<ol style="list-style-type: none"> Check speaker. Check radio output voltages. Check wires for open or short between radio and speaker. Remove radio for repair.
Radio stations are weak or noisy	<ol style="list-style-type: none"> Antenna Poor radio ground Radio 	<ol style="list-style-type: none"> Check antenna. Check radio ground. Remove radio for repair.
FM stations are weak or noisy (AM stations OK). (For premium audio system)	<ol style="list-style-type: none"> Window antenna Radio 	<ol style="list-style-type: none"> Check window antenna. Remove radio for repair.
Radio generates noise in AM and FM modes with engine running.	<ol style="list-style-type: none"> Poor radio ground Loose or missing ground bonding straps Ignition condenser or rear window defogger noise suppressor condenser Generator Ignition coil or secondary wiring Radio 	<ol style="list-style-type: none"> Check radio ground. Check ground bonding straps. Replace ignition condenser or rear window defogger noise suppressor condenser. Check generator. Check ignition coil and secondary wiring. Remove radio for repair.
Radio generates noise in AM and FM modes with accessories on (switch pops and motor noise).	<ol style="list-style-type: none"> Poor radio ground Antenna Accessory ground Faulty accessory 	<ol style="list-style-type: none"> Check radio ground. Check antenna. Check accessory ground. Replace accessory.

GI

MA

EM

LC

EC

FE

CL

MT

AT

FA

RA

BR

ST

RS

BT

HA

EL

IDX

Inspection

SPEAKER

1. Disconnect speaker harness connector.
2. Measure the resistance between speaker terminals ⊕ and ⊖.
 - The resistance should be 2 - 4Ω.
3. Using jumper wires, momentarily connect a 9V battery between speaker terminals ⊕ and ⊖.
 - A momentary hum or pop should be heard.

ANTENNA

Using a jumper wire, clip an auxiliary ground between antenna and body.

- If reception improves, check antenna ground (at body surface).
- If reception does not improve, check main feeder cable for short circuit or open circuit.

RADIO

All voltage inspections are made with:

- Ignition switch ON or ACC
- Radio ON
- Radio connected (If removed for inspection, supply a ground to the case using a jumper wire).

AUDIO ANTENNA

System Description

Power is supplied at all times:

- through 10A fuse [No. 24, located in the fuse block (J/B)]
- to power antenna terminal ⑥.

Ground is supplied to the power antenna terminal ② through body grounds T6 and T9 .

When the audio is turned to the ON position, battery positive voltage is supplied:

- through audio terminal ⑤
- to power antenna terminal ④.

The antenna rises and is held in the extended position.

When the audio is turned to the OFF position, battery positive voltage is interrupted:

- from audio terminal ⑤
- to power antenna terminal ④.

The antenna retracts.

GI

MA

EM

LC

EC

FE

CL

MT

AT

FA

RA

BR

ST

RS

BT

HA

EL

IDX

AUDIO ANTENNA

Wiring Diagram — P/ANT —

EL-P/ANT-01

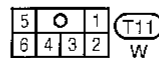
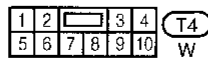
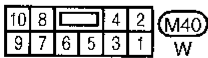
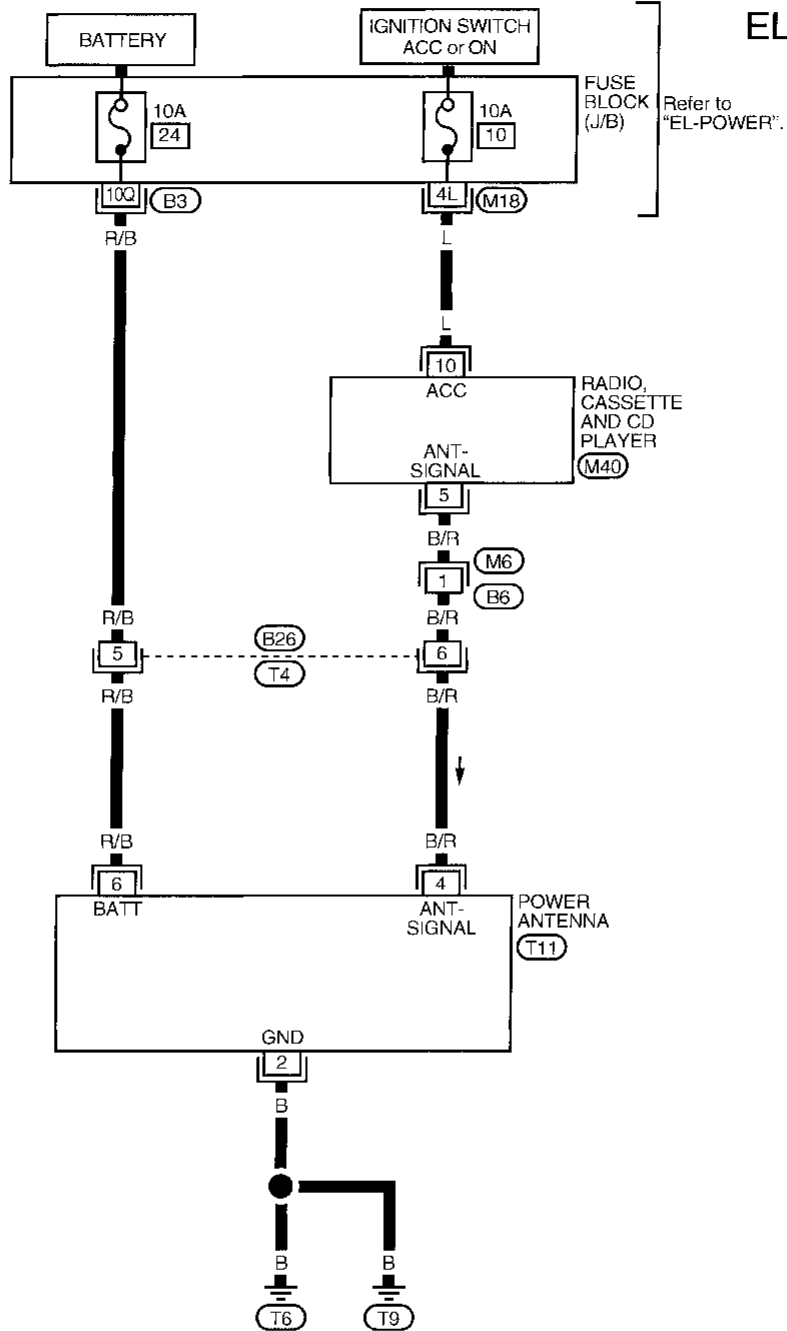

AUDIO ANTENNA

Trouble Diagnoses

POWER ANTENNA

Symptom	Possible causes	Repair order
Power antenna does not operate.	<ol style="list-style-type: none"> 10A fuse Radio signal Grounds T6 and T9 	<ol style="list-style-type: none"> Check 10A fuse [No. 24, located in fuse block (J/B)]. Verify that battery positive voltage is present at terminal 6 of power antenna. Turn ignition switch and radio ON. Verify that battery positive voltage is present at terminal 4 of power antenna. Check grounds T6 and T9.

Location of Antenna

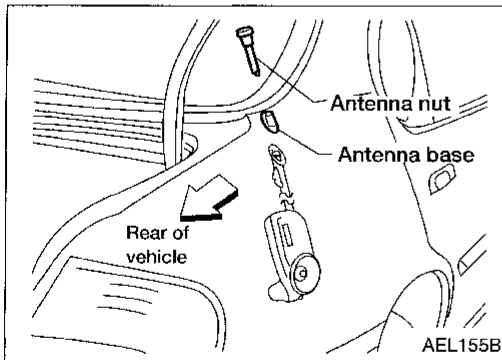
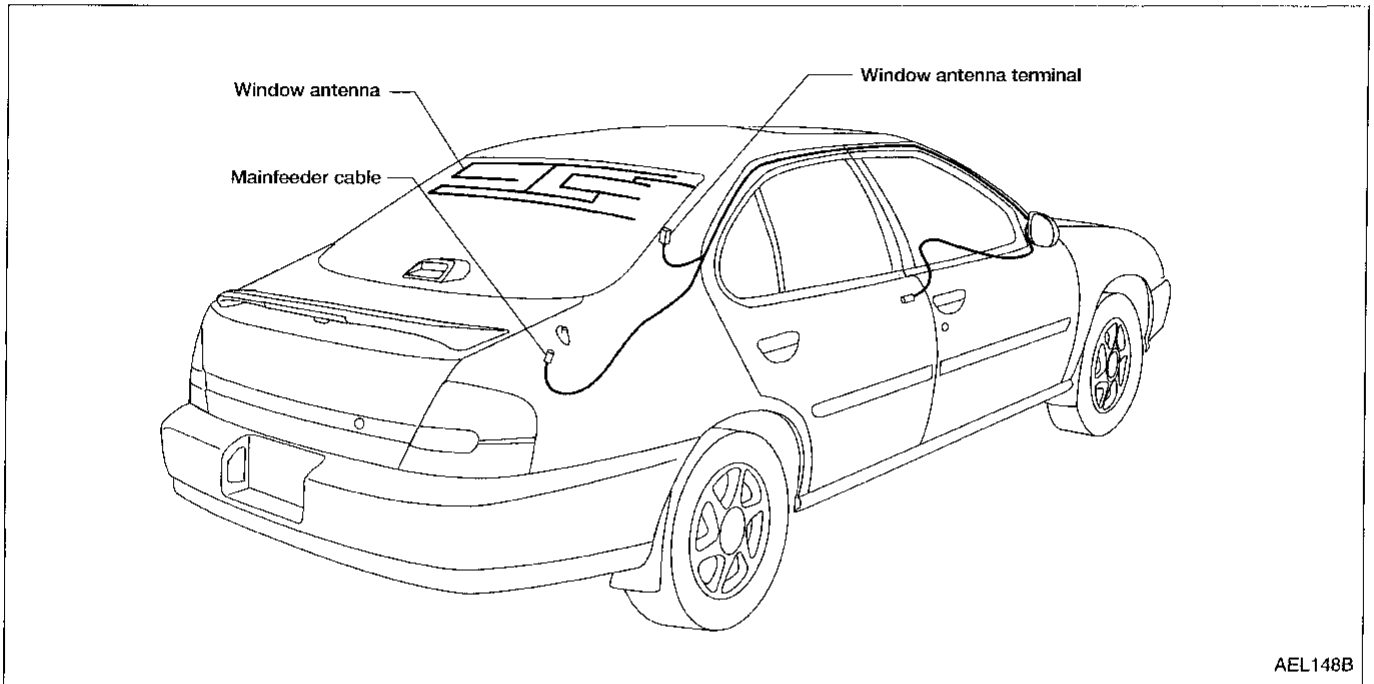

Antenna Rod Replacement

REMOVAL

1. Remove antenna nut and antenna base.

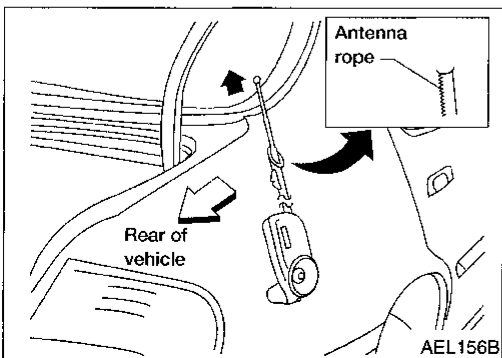

2. Withdraw antenna rod while raising it by operating antenna motor.

AUDIO ANTENNA

Antenna Rod Replacement (Cont'd)

INSTALLATION

1. Lower antenna rod by operating antenna motor.
2. Insert gear section of antenna rope into place with it facing toward antenna motor.
3. As soon as antenna rope is wound on antenna motor, stop antenna motor. Insert antenna rod lower end into antenna motor pipe.
4. Retract antenna rod completely by operating antenna motor.
5. Install antenna nut and base.

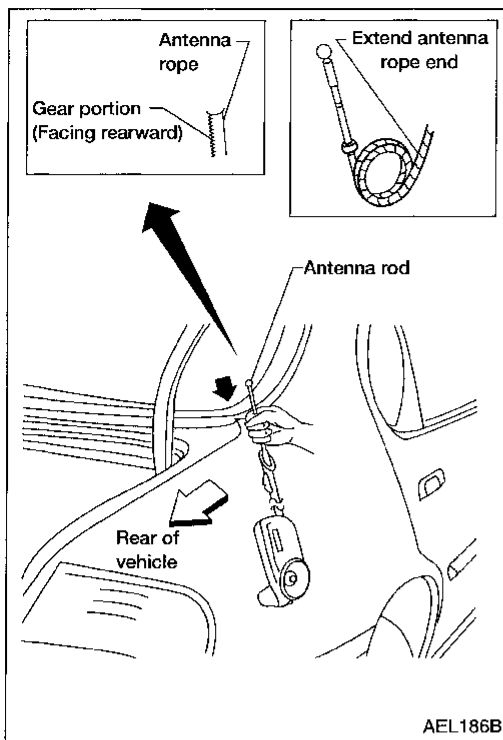

AUDIO ANTENNA

Fixed Antenna Rod Replacement

REMOVAL

1. Remove antenna mast.
2. Remove antenna nut and antenna base.
3. Disconnect antenna cable.
4. Remove bolt and antenna.

INSTALLATION

Install in reverse order of removal.

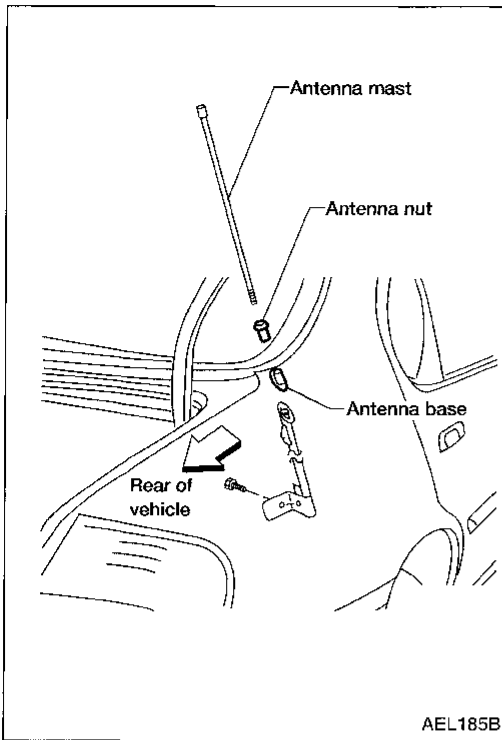

GI

MA

EM

LC

EC

FE

CL

MT

AT

FA

RA

BR

ST

RS

BT

HA

EL

IDX

Window Antenna Repair

ELEMENT CHECK

1. Attach probe circuit tester (in ohm range) to antenna terminal on each side.

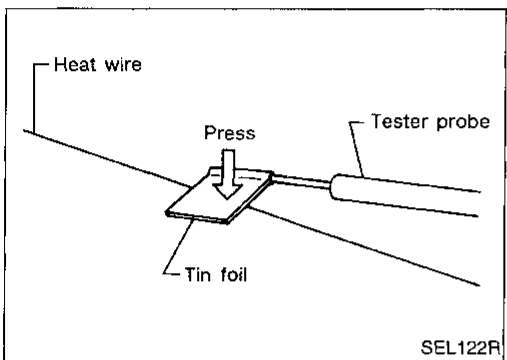
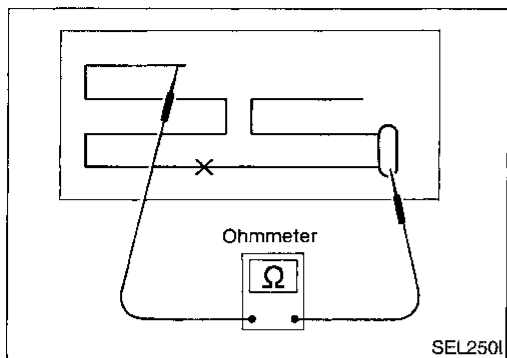

- When measuring continuity, wrap tin foil around the top of probe. Then press the foil against the wire with your finger.

2. If an element is broken, no continuity will exist.

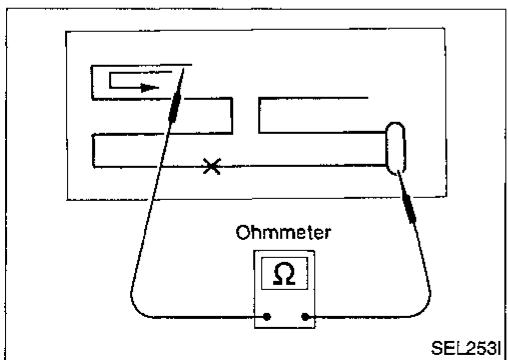
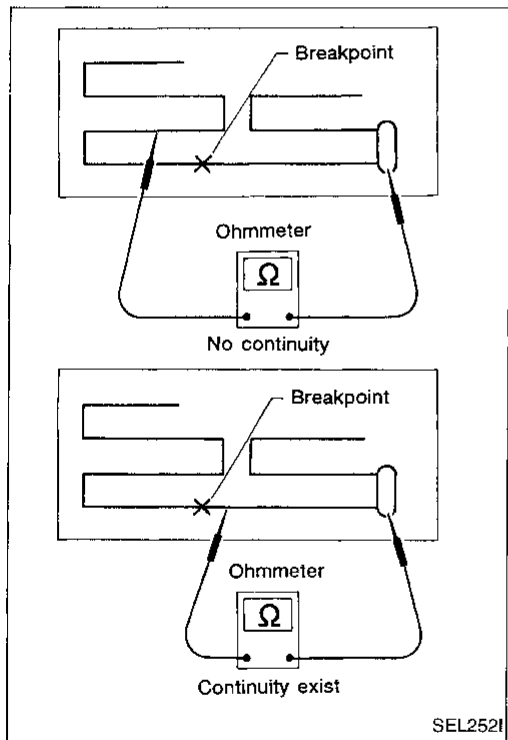

3. To locate broken point, move probe along element. Tester needle will swing abruptly when probe passes the point.

ELEMENT REPAIR

Refer to "Filament Repair", "REAR WINDOW DEFOGGER" (EL-122).

ELECTRIC SUNROOF

Wiring Diagram — SROOF — (Cont'd)

EL-SROOF-02

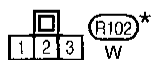
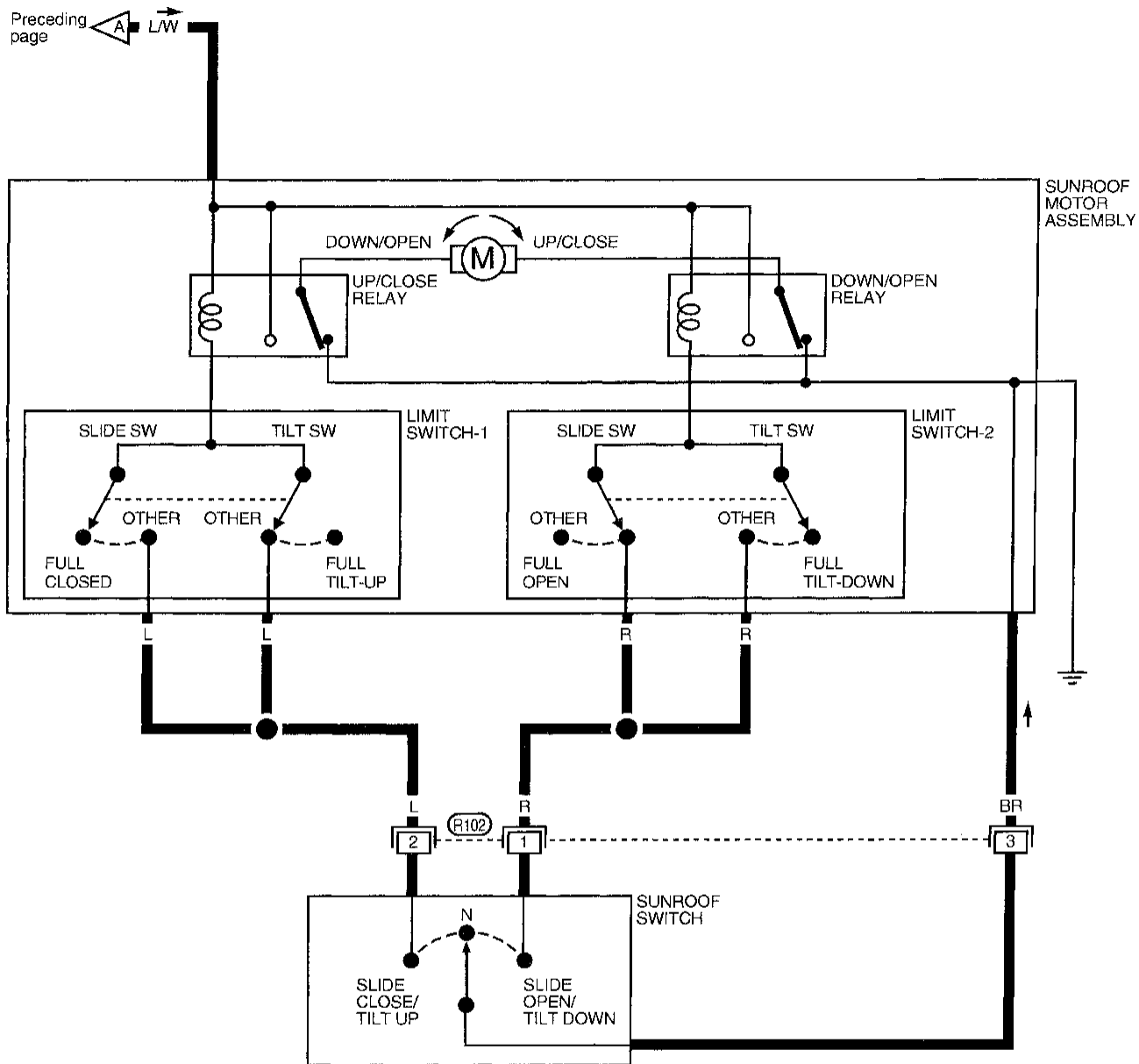

* : This connector is not shown in "HARNESS LAYOUT" of EL section.

POWER DOOR MIRROR

Wiring Diagram — MIRROR —

EL-MIRROR-01

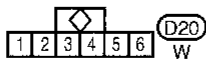
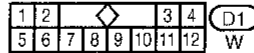
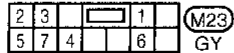
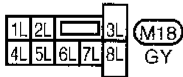
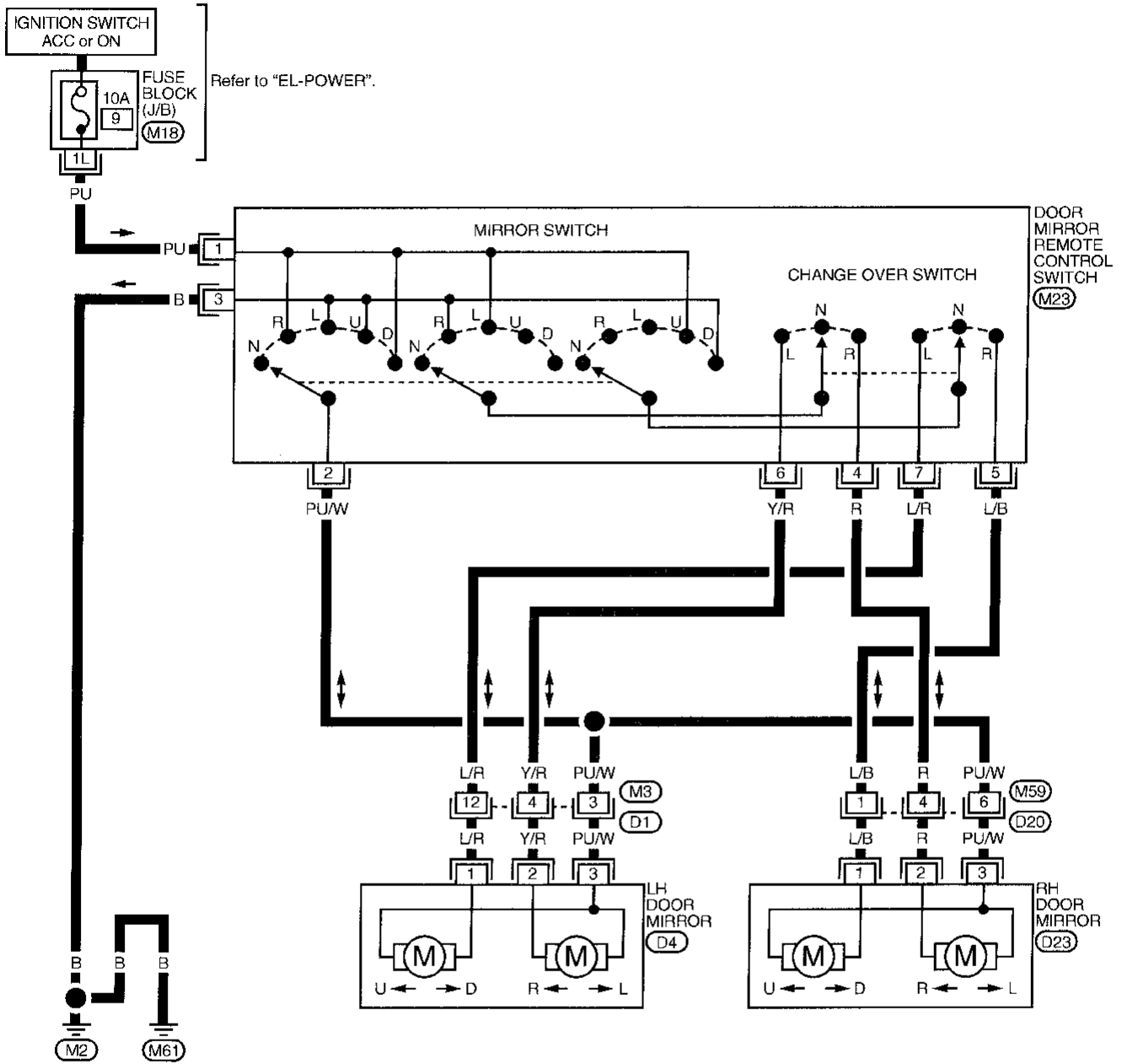

GI
MA
EM
LC
EC
FE
CL
MT
AT
FA
RA
BR
ST
RS
BT
HA
EL
IDX

AUTOMATIC SPEED CONTROL DEVICE (ASCD)

Component Parts and Harness Connector Location

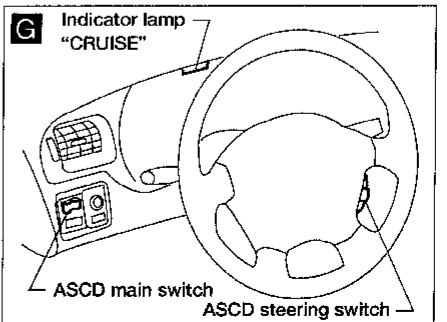
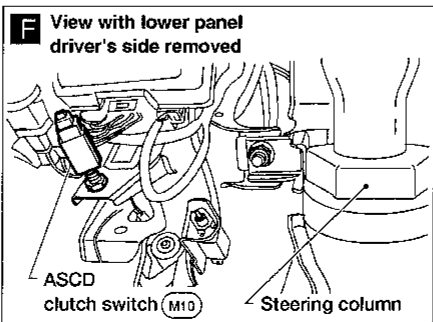
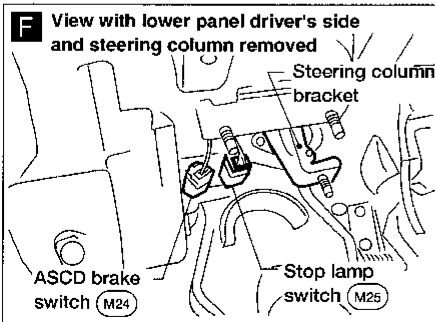
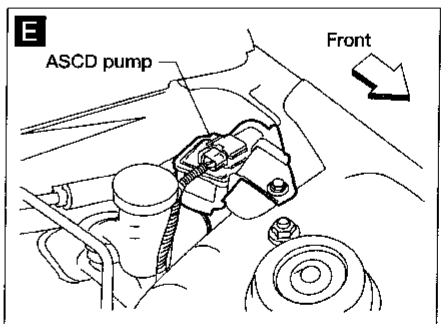
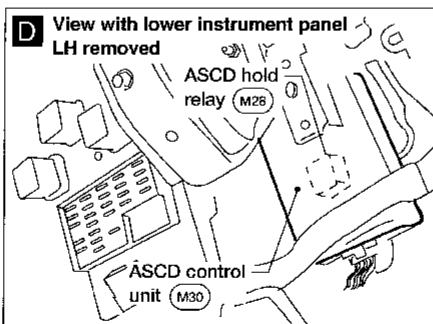
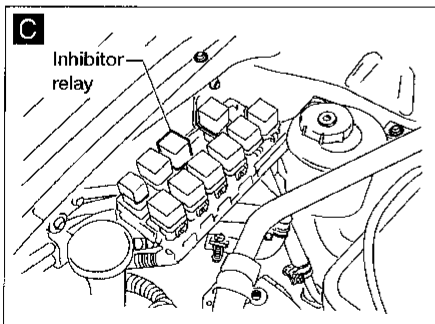
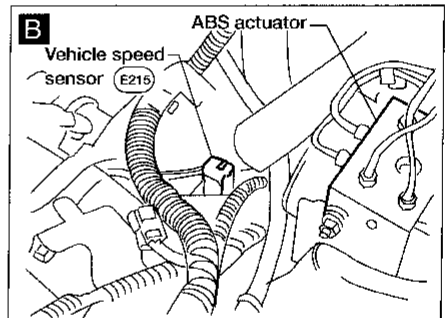
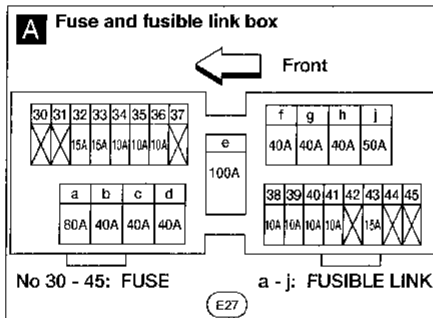
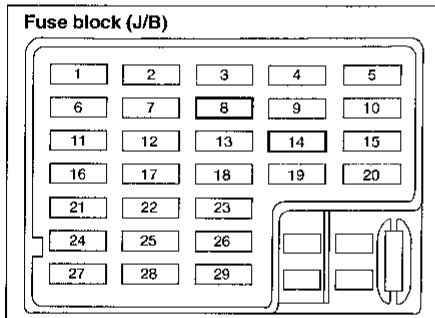
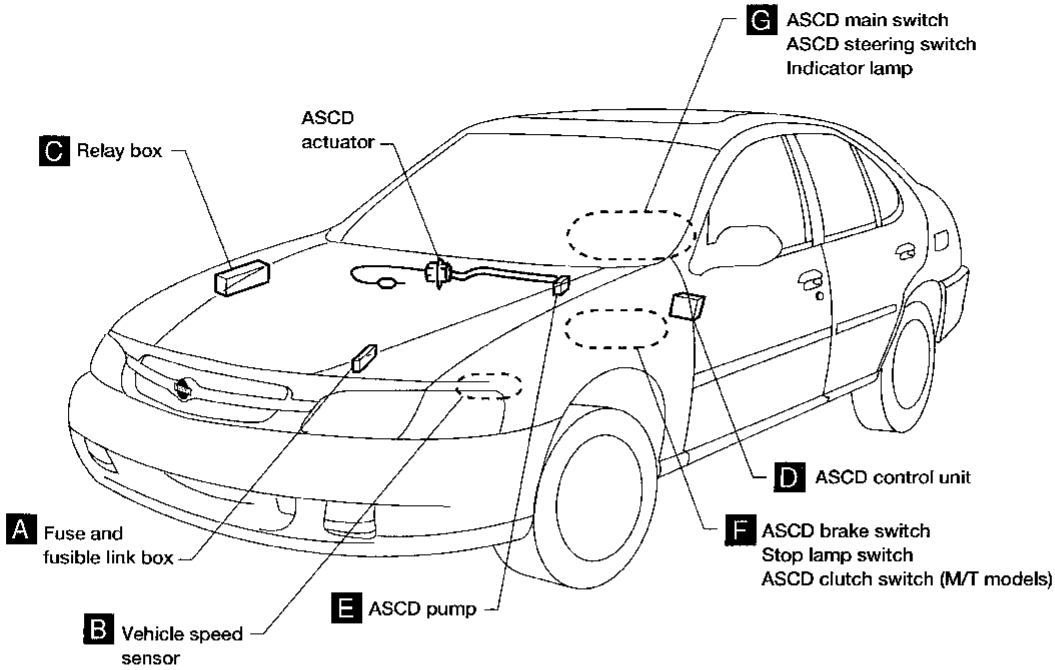

GI
MA
EM
LC
EC
FE
CL
MT
AT
FA
RA
BR
ST
RS
BT
HA
EL
IDX

System Description

Refer to Owner's Manual for ASCD operating instructions.

When the ignition switch is in the ON or START position, power is supplied:

- through 10A fuse [No. 8], located in the fuse block (J/B)]
- to ASCD main switch terminal ① and
- to ASCD hold relay terminal ⑤
- to ASCD brake switch terminal ② (with A/T)
- through ASCD brake switch terminal ①
- to ASCD hold relay terminal ⑥ (with A/T).

When ASCD main switch is in the ON position, power is supplied:

- from terminal ② of the ASCD main switch
- to ASCD control unit terminal ④ and
- from terminal ③ of the ASCD main switch
- to ASCD hold relay terminal ① (with M/T) terminal ② (with A/T).

Ground is supplied:

- to ASCD main switch terminal ④
- to ASCD hold relay terminal ② (with M/T) terminal ① (with A/T)
- through body grounds (M2) and (M61).

With power and ground supplied, the ASCD hold relay is activated, and power is supplied:

- from terminal ③ of the ASCD hold relay
- through ASCD main switch terminals ② and ③
- to ASCD hold relay terminal ① (with M/T) terminal ② (with A/T).

Power remains supplied when the ASCD switch is released to the N (neutral) position:

- from terminal ③ of ASCD hold relay
- to ASCD control unit terminal ④ and
- to ASCD clutch switch terminal ① (with M/T)
- from terminal ⑦ of ASCD hold relay (with A/T)
- to inhibitor relay terminal ③ (with A/T).

Ground is supplied:

- to ASCD control unit terminal ③
- through body grounds (M2) and (M61).

INPUTS

At this point, the system is ready to activate or deactivate, based on inputs from the following:

- speedometer in the combination meter
- stop lamp switch
- ASCD steering switch
- ASCD clutch switch (M/T models) or
- inhibitor relay (A/T models)
- ASCD brake switch.

A vehicle speed input is supplied:

- to ASCD control unit terminal ⑦
- from terminal ⑤ of the combination meter.

Power is supplied at all times:

- to stop lamp switch terminal ①
- through 15A fuse [No. 14], located in the fuse block (J/B)].

When the brake pedal is depressed, power is supplied:

- from terminal ② of the stop lamp switch
- to ASCD control unit terminal ⑩.

Power is supplied at all times:

- through 10A fuse [No. 40], located in the fuse and fusible link box]
- to horn relay terminal ②
- through terminal ① of the horn relay
- to ASCD steering switch terminal ③.

When the SET/COAST switch is depressed, power is supplied:

- from terminal ② of the ASCD steering switch
- to ASCD control unit terminal ②.

When the RESUME/ACCEL switch is depressed, power is supplied:

AUTOMATIC SPEED CONTROL DEVICE (ASCD)

System Description (Cont'd)

- from terminal ① of the ASCD steering switch
- to ASCD control unit terminal ①.

When the system is activated, power is supplied:

- from ASCD brake switch terminal ② (with M/T) or
- from inhibitor relay terminal ④ (with A/T)
- to ASCD control unit terminal ⑤.

Power is interrupted when:

- the ASCD main switch is turned to OFF
- the clutch switch is depressed (M/T models),
- the A/T selector lever is placed in P or N (A/T models) or
- the ASCD brake switch is depressed.

OUTPUTS

The ASCD actuator controls the throttle drum via the ASCD wire based on inputs from the ASCD control unit. The ASCD pump consists of a vacuum motor, an air valve, and a release valve.

Power is supplied:

- from terminal ⑧ of the ASCD control unit
- to ASCD pump terminal ①.

Ground is supplied to the vacuum motor:

- from terminal ⑨ of the ASCD control unit
- to ASCD pump terminal ④.

Ground is supplied to the air valve:

- from terminal ⑩ of the ASCD control unit
- to ASCD pump terminal ②.

Ground is supplied to the release valve:

- from terminal ⑭ of the ASCD control unit
- to ASCD pump terminal ③.

When the system is activated, power is supplied:

- from terminal ⑬ of the ASCD control unit
- to combination meter terminal ⑳ and
- to transmission control module terminal ⑳ (A/T models).

Ground is supplied:

- to combination meter terminals ⑳ and ㉑
- through body grounds M2 and M61.

With power and ground supplied, the CRUISE indicator illuminates.

When vehicle speed is approximately 8 km/h (5 MPH) below set speed on A/T models, a signal is sent

- from terminal ⑫ of the ASCD control unit
- to transmission control module unit terminal ㉒.

When this occurs, the transmission control module cancels overdrive.

After vehicle speed is approximately 3 km/h (2 MPH) above set speed, overdrive is reactivated.

GI

MA

EM

LC

EC

FE

CL

MT

AT

FA

RA

BR

ST

RS

BT

HA

EL

IDX

AUTOMATIC SPEED CONTROL DEVICE (ASCD)

Schematic

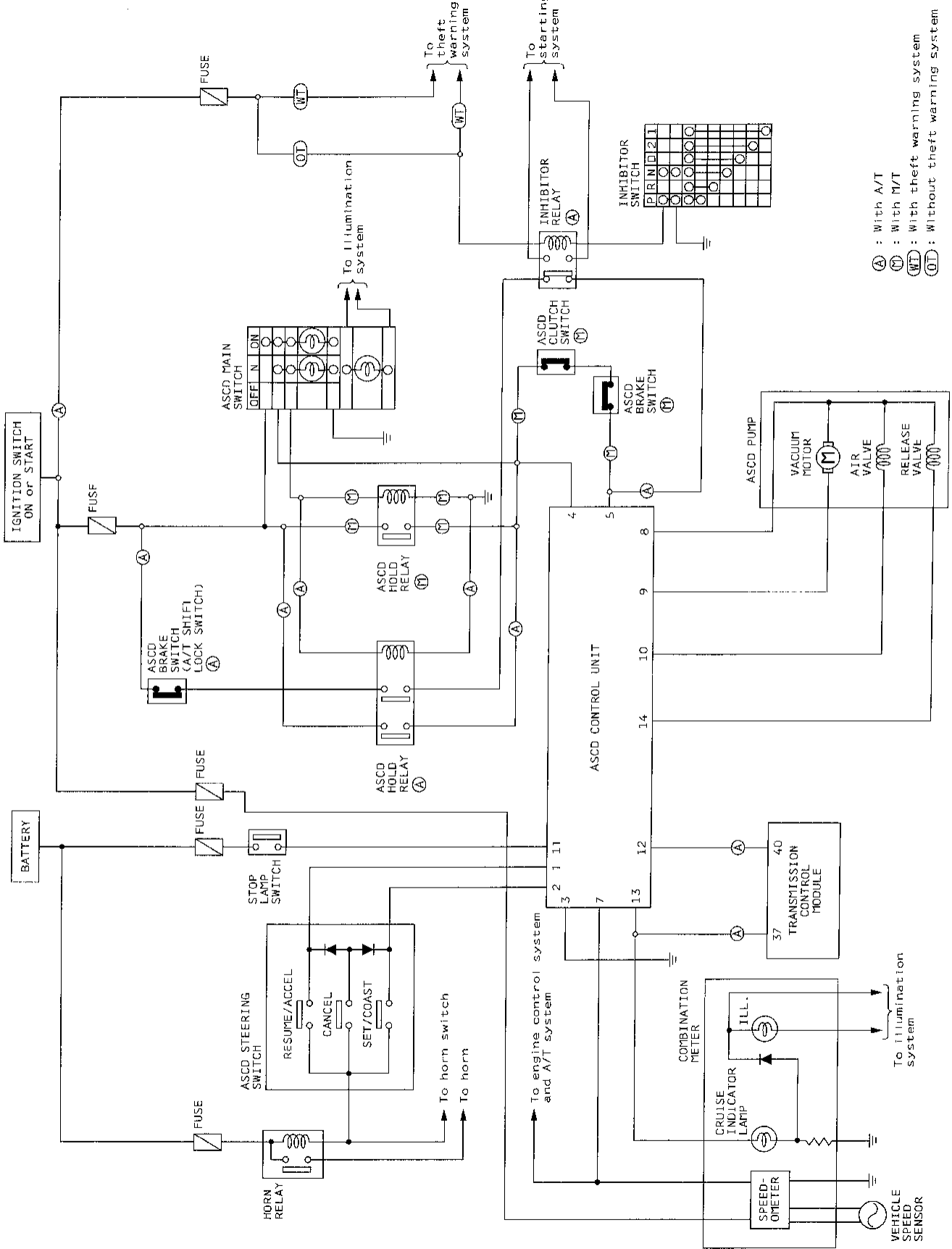

AUTOMATIC SPEED CONTROL DEVICE (ASCD)

Wiring Diagram — ASCD —

EL-ASCD-01

GI

MA

EM

LC

EC

FE

CL

MT

AT

FA

RA

BR

ST

RS

BT

HA

EL

IDX

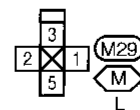
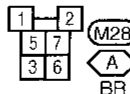
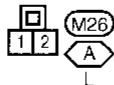
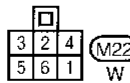
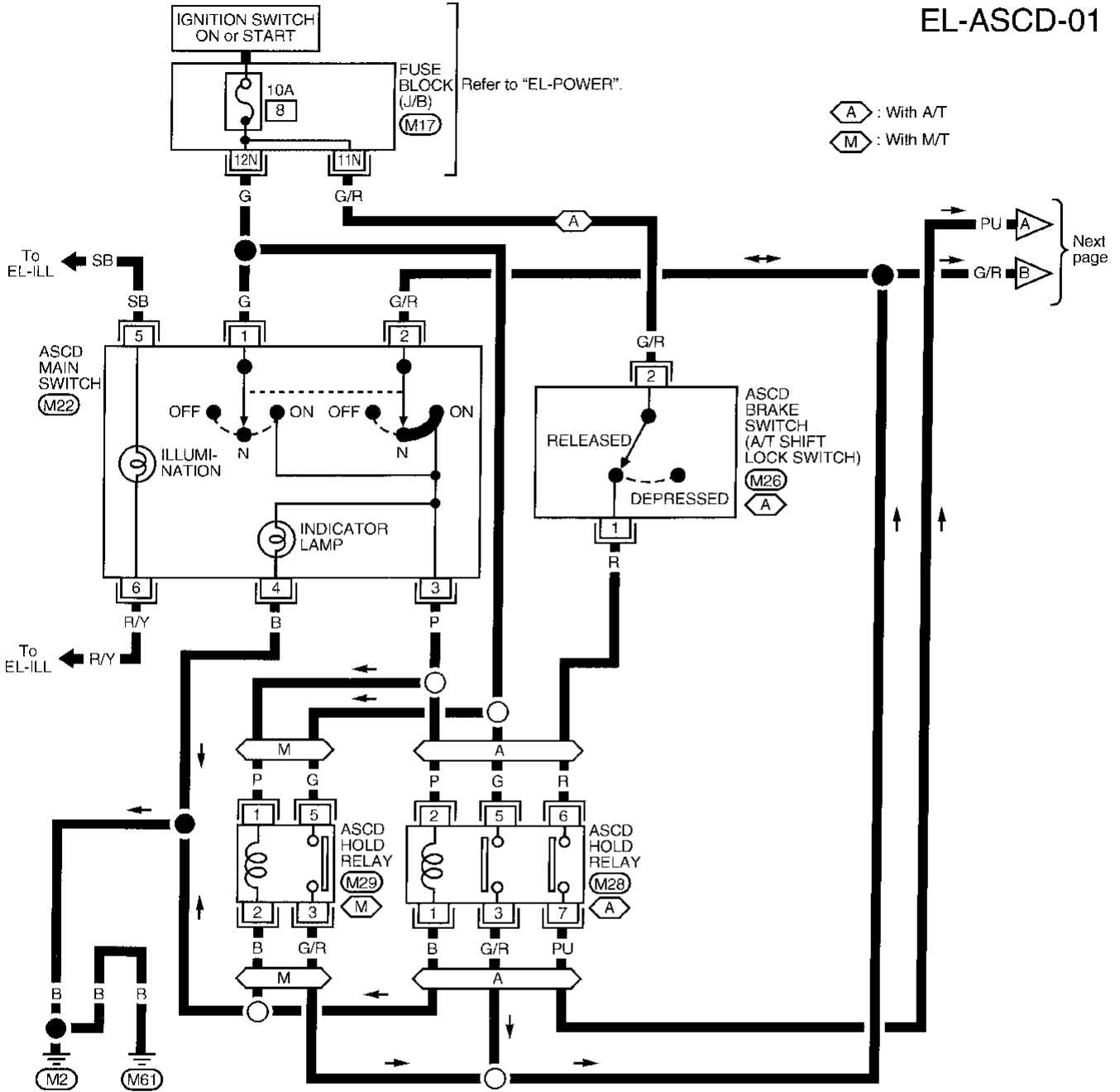

AUTOMATIC SPEED CONTROL DEVICE (ASCD)

Wiring Diagram — ASCD — (Cont'd)

EL-ASCD-02

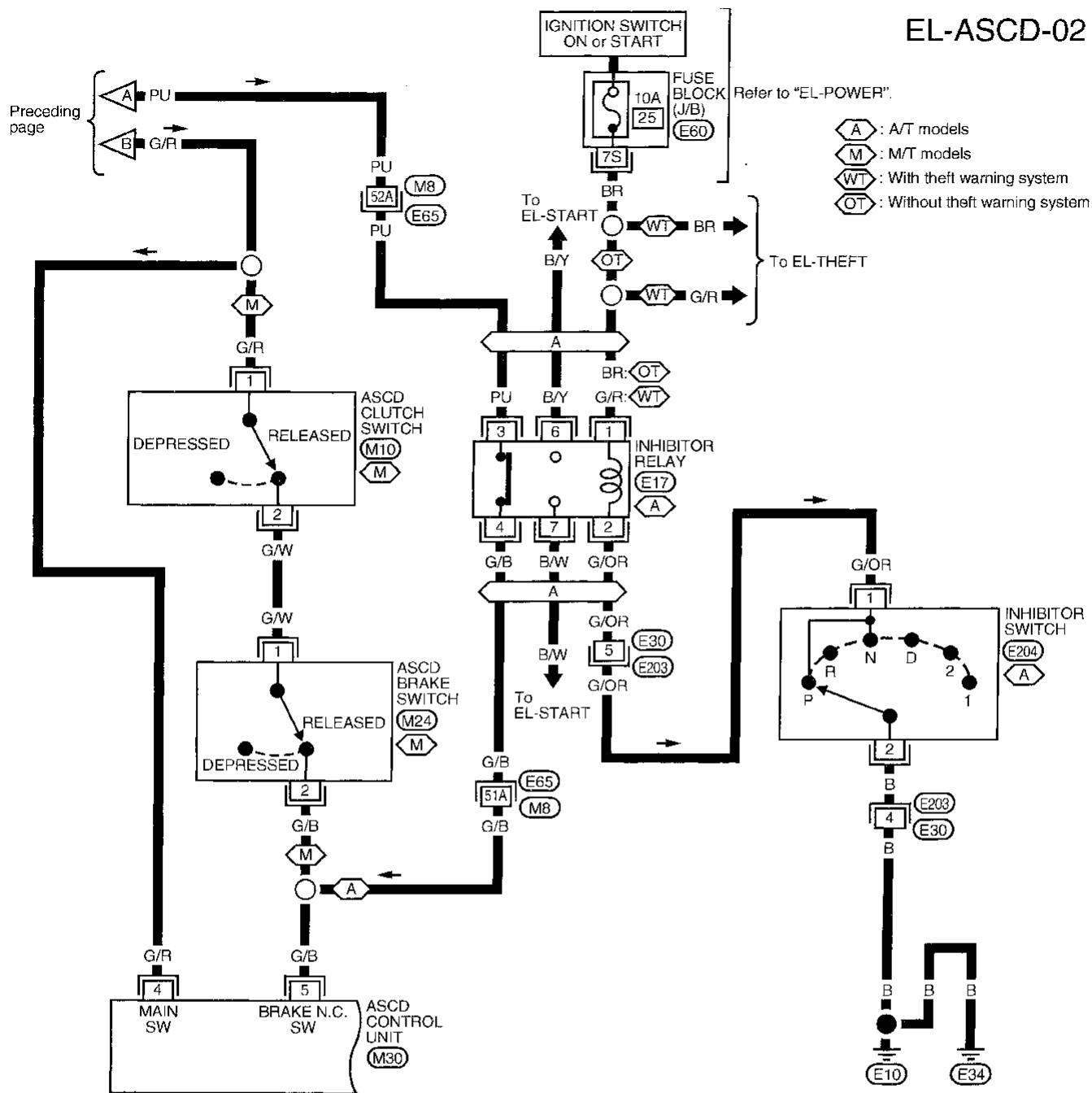

- (A) : A/T models
- (M) : M/T models
- (WT) : With theft warning system
- (OT) : Without theft warning system

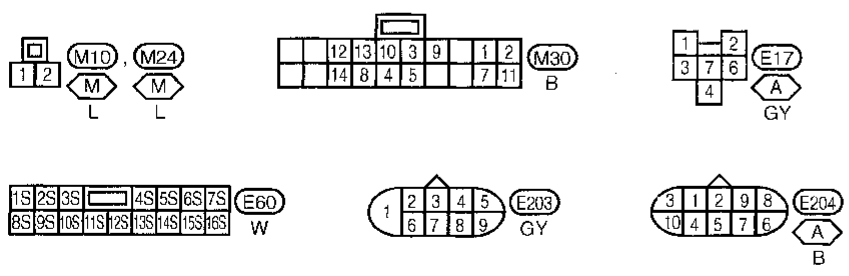

Refer to last page (Foldout page).
 (M8), (E65)

AUTOMATIC SPEED CONTROL DEVICE (ASCD)

Wiring Diagram — ASCD — (Cont'd)

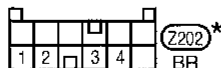
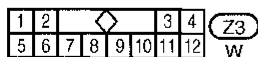
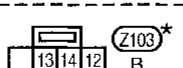
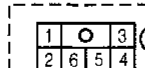
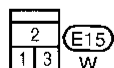
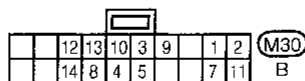
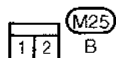
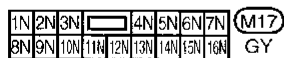
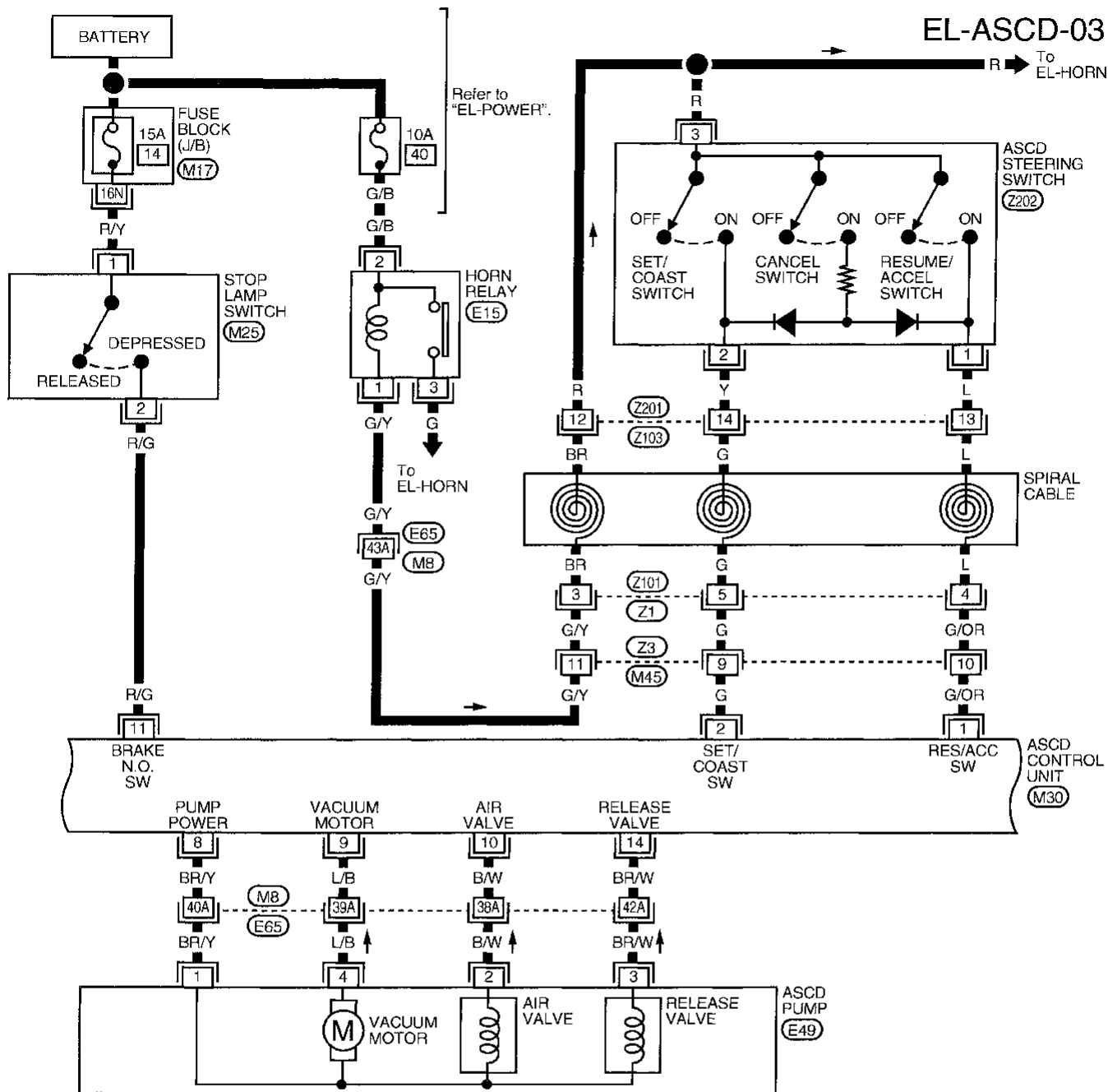

Refer to last page (Foldout page).

(M8), (E65)

* : This connector is not shown in "HARNES LAYOUT" of EL section.

AUTOMATIC SPEED CONTROL DEVICE (ASCD)

Wiring Diagram — ASCD — (Cont'd)

EL-ASCD-04

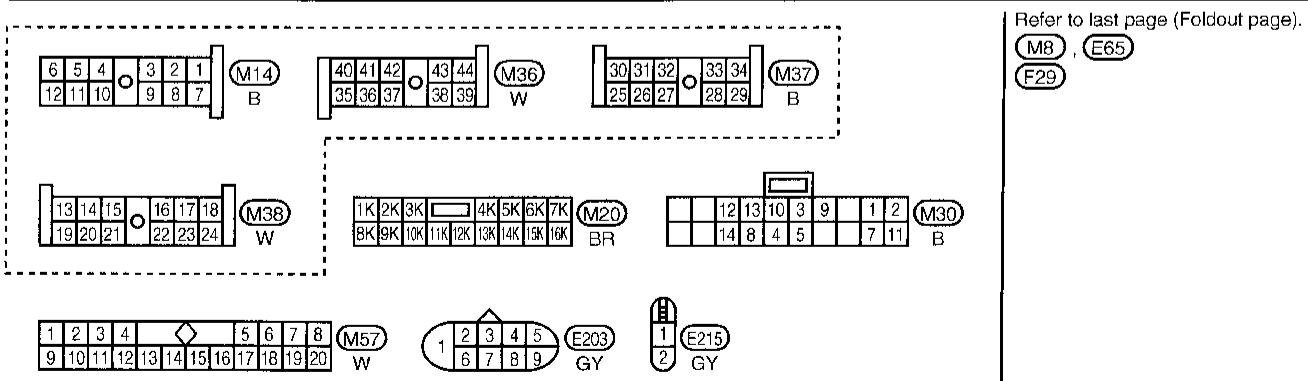
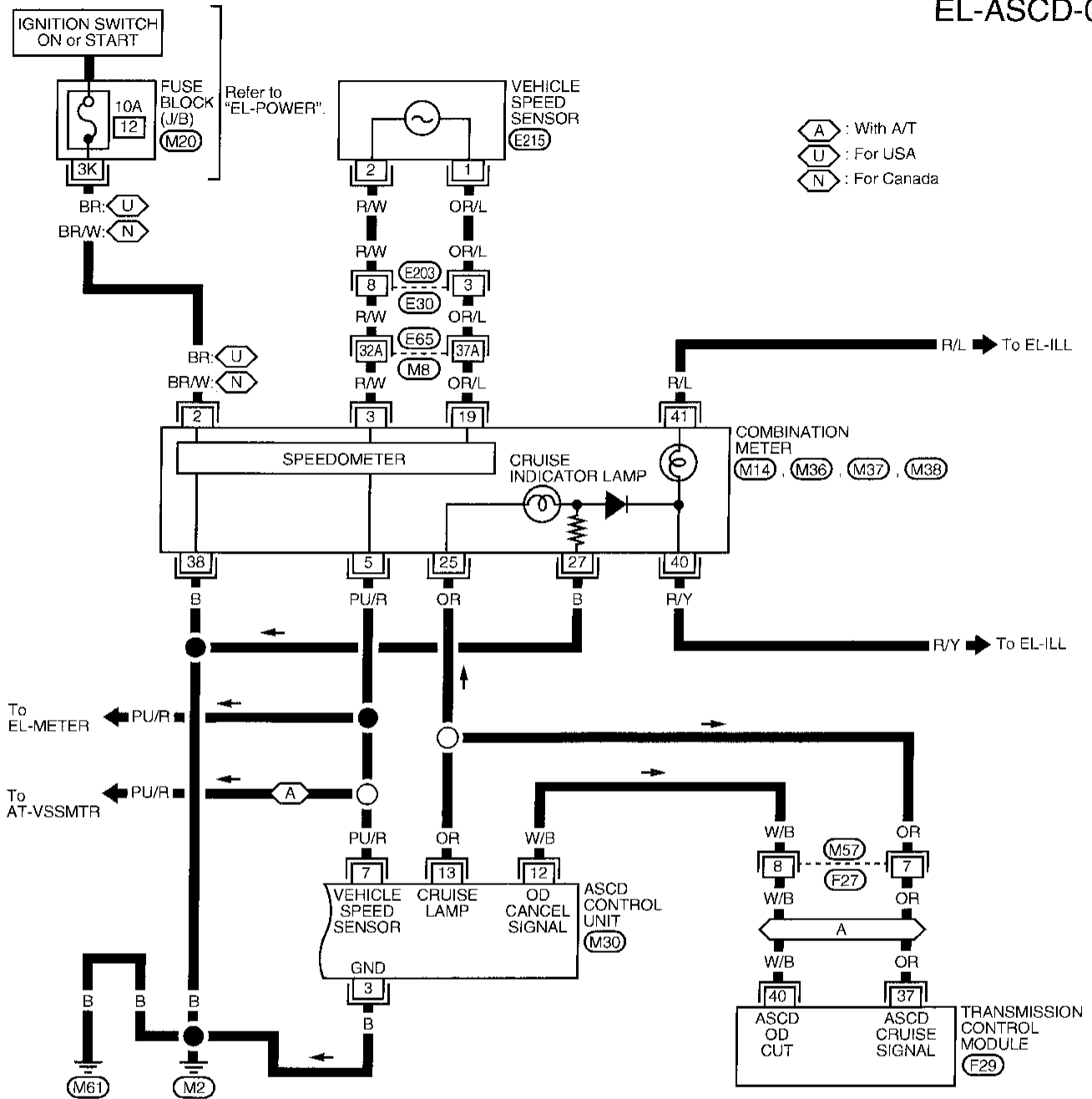

AUTOMATIC SPEED CONTROL DEVICE (ASCD)

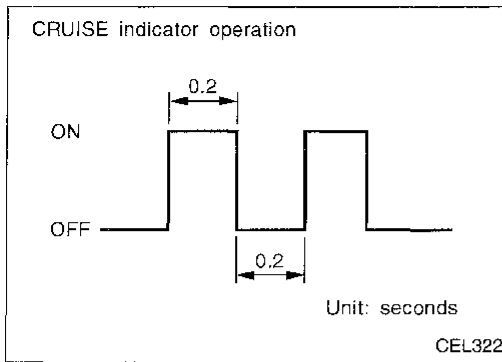

Fail-safe System Description

When the fail-safe system senses a malfunction, it deactivates ASCD operation. The CRUISE indicator in the combination meter will then flash.

MALFUNCTION DETECTION CONDITIONS

Detection conditions	ASCD operation during malfunction detection
<ul style="list-style-type: none"> ● ASCD steering (RESUME/ACCEL, CANCEL, SET/COAST) switch is stuck. ● Vacuum motor ground circuit or power circuit is open or shorted. ● Air valve ground circuit or power circuit is open or shorted. ● Release valve ground circuit or power circuit is open or shorted. ● Vehicle speed sensor is faulty. ● ASCD control unit internal circuit is malfunctioning. 	<ul style="list-style-type: none"> ● ASCD is deactivated. ● Vehicle speed memory is canceled.
<ul style="list-style-type: none"> ● ASCD brake switch or stop lamp switch is faulty. 	<ul style="list-style-type: none"> ● ASCD is deactivated. ● Vehicle speed memory is not canceled.

GI

MA

EM

LC

EC

FE

CL

MT

AT

FA

RA

BR

ST

RS

BT

HA

EL

IDX

AUTOMATIC SPEED CONTROL DEVICE (ASCD)

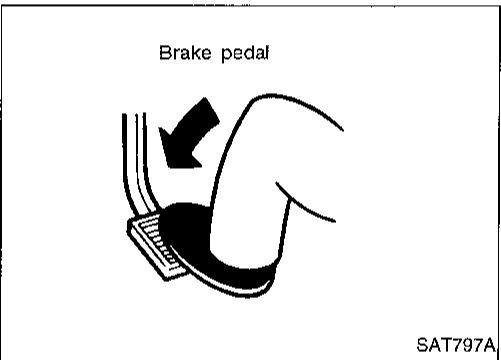
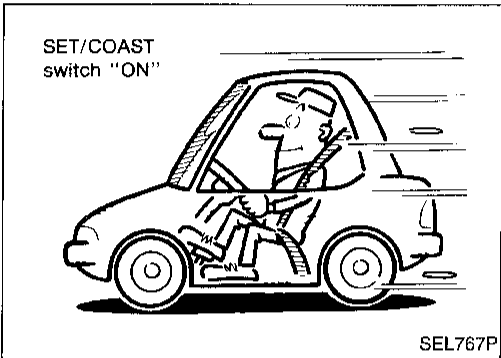
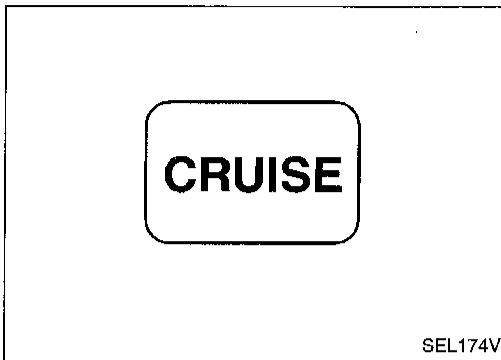

Fail-Safe System Check

1. Turn ignition switch ON.
2. Turn ASCD main switch to ON position and check if the "cruise indicator" blinks.

If the indicator lamp blinks, check the following.

- ASCD steering switch. Refer to "DIAGNOSTIC PROCEDURE 5" (EL-155).

3. Drive the vehicle at more than 48 km/h (30 MPH) and push SET/COAST switch.

If the indicator lamp blinks, check the following:

- Vehicle speed sensor. Refer to "DIAGNOSTIC PROCEDURE 6" (EL-156).
- ASCD pump circuit. Refer to "DIAGNOSTIC PROCEDURE 7" (EL-157).
- Replace control unit.

4. Depress brake pedal slowly (brake pedal should be depressed more than 5 seconds).

If the indicator lamp blinks, check the following:

- ASCD brake/stop lamp switch. Refer to "DIAGNOSTIC PROCEDURE 4" (EL-154).

5. END. (System is OK.)

AUTOMATIC SPEED CONTROL DEVICE (ASCD)

Trouble Diagnoses

SYMPTOM CHART

PROCEDURE	Diagnostic procedure								
REFERENCE PAGE	EL-150	EL-152	EL-152	EL-153	EL-154	EL-155	EL-156	EL-157	EL-158
SYMPTOM	Fail-safe system check	DIAGNOSTIC PROCEDURE 1 (POWER SUPPLY AND GROUND CIRCUIT CHECK)	DIAGNOSTIC PROCEDURE 2 (ASCD MAIN SWITCH CHECK)	DIAGNOSTIC PROCEDURE 3 (ASCD HOLD RELAY CHECK)	DIAGNOSTIC PROCEDURE 4 (ASCD BRAKE/STOP LAMP SWITCH CHECK)	DIAGNOSTIC PROCEDURE 5 (ASCD STEERING SWITCH CHECK)	DIAGNOSTIC PROCEDURE 6 (VEHICLE SPEED SENSOR CHECK)	DIAGNOSTIC PROCEDURE 7 (ASCD PUMP CIRCUIT CHECK)	DIAGNOSTIC PROCEDURE 8 (ASCD ACTUATOR/PUMP CHECK)
ASCD cannot be set. ("CRUISE" indicator lamp does not blink.)		X	X	X		X	X		
ASCD cannot be set. ("CRUISE" indicator lamp blinks.★1)	X				X	X	X	X	
Vehicle speed does not decrease after SET/COAST switch has been pressed.						X			X
Vehicle speed does not return to the set speed after RESUME/ACCEL switch has been pressed.★2						X			X
Vehicle speed does not increase after RESUME/ACCEL switch has been pressed.						X			X
System is not released after CANCEL switch (steering) has been pressed.						X			X
Large difference between set speed and actual vehicle speed.									X
Deceleration is greatest immediately after ASCD has been set.									X

★1: It indicates that system is in fail-safe. After completing diagnostic procedures, perform "Fail-Safe System Check" (EL-150) to verify repairs.

★2: If vehicle speed is greater than 48 km/h (30 MPH) after system has been released, pressing RESUME/ACCEL switch returns vehicle speed to the set speed previously achieved. However, doing so when the ASCD main switch is turned to "OFF", vehicle speed will not return to the set speed since the memory is canceled.

AUTOMATIC SPEED CONTROL DEVICE (ASCD)

Trouble Diagnoses (Cont'd)

DIAGNOSTIC PROCEDURE 1

(POWER SUPPLY AND GROUND CIRCUIT CHECK)

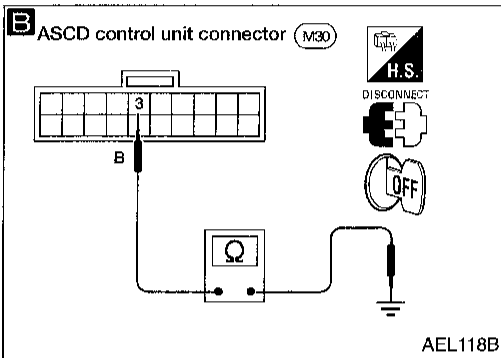
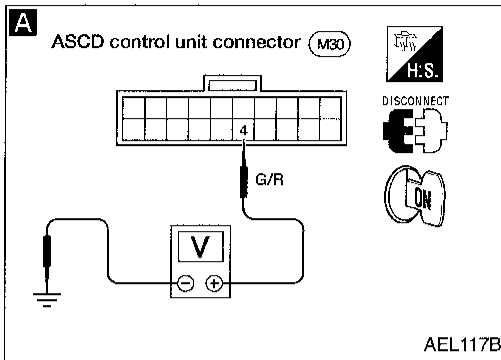

1. Turn ignition switch ON.
2. Turn ASCD main switch "ON" to make sure indicators illuminate.

NG

Go to DIAGNOSTIC PROCEDURE 2 (ASCD MAIN SWITCH CHECK).

OK

A

CHECK POWER SUPPLY CIRCUIT FOR ASCD CONTROL UNIT.

1. Disconnect ASCD control unit connector.
2. Turn ignition switch ON.
3. Turn ASCD main switch "ON".
4. Check voltage between control unit connector terminal ④ and ground. **Battery voltage should exist.**

Refer to wiring diagram in EL-146.

NG

Go to DIAGNOSTIC PROCEDURE 3 (ASCD HOLD RELAY CIRCUIT CHECK). Refer to EL-153.

OK

B

CHECK GROUND CIRCUIT FOR ASCD CONTROL UNIT.

Check continuity between ASCD control unit harness terminal ③ and body ground.

Refer to wiring diagram in EL-148.

NG

Repair harness.

OK

Go to next procedure.

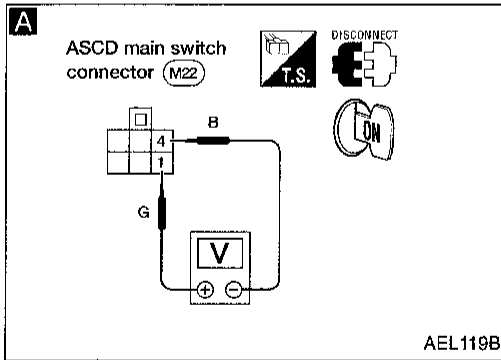

DIAGNOSTIC PROCEDURE 2

(ASCD MAIN SWITCH CHECK)

A

CHECK POWER SUPPLY FOR ASCD MAIN SWITCH.

1. Disconnect ASCD main switch connector.
2. Measure voltage between main switch terminals ① and ④. **Battery voltage should exist.**

Refer to wiring diagram in EL-145.

NG

- Check the following.
- 10A fuse [No. ⑧], located in the fuse block (J/B)
 - Harness for open or short between fuse and ASCD main switch
 - Ground circuit for ASCD main switch

OK

CHECK ASCD MAIN SWITCH. Refer to "Electrical Components Inspection", EL-160.

NG

Replace ASCD main switch.

OK

Go to next procedure.

AUTOMATIC SPEED CONTROL DEVICE (ASCD)

Trouble Diagnoses (Cont'd)

DIAGNOSTIC PROCEDURE 3

(ASCD HOLD RELAY CHECK)

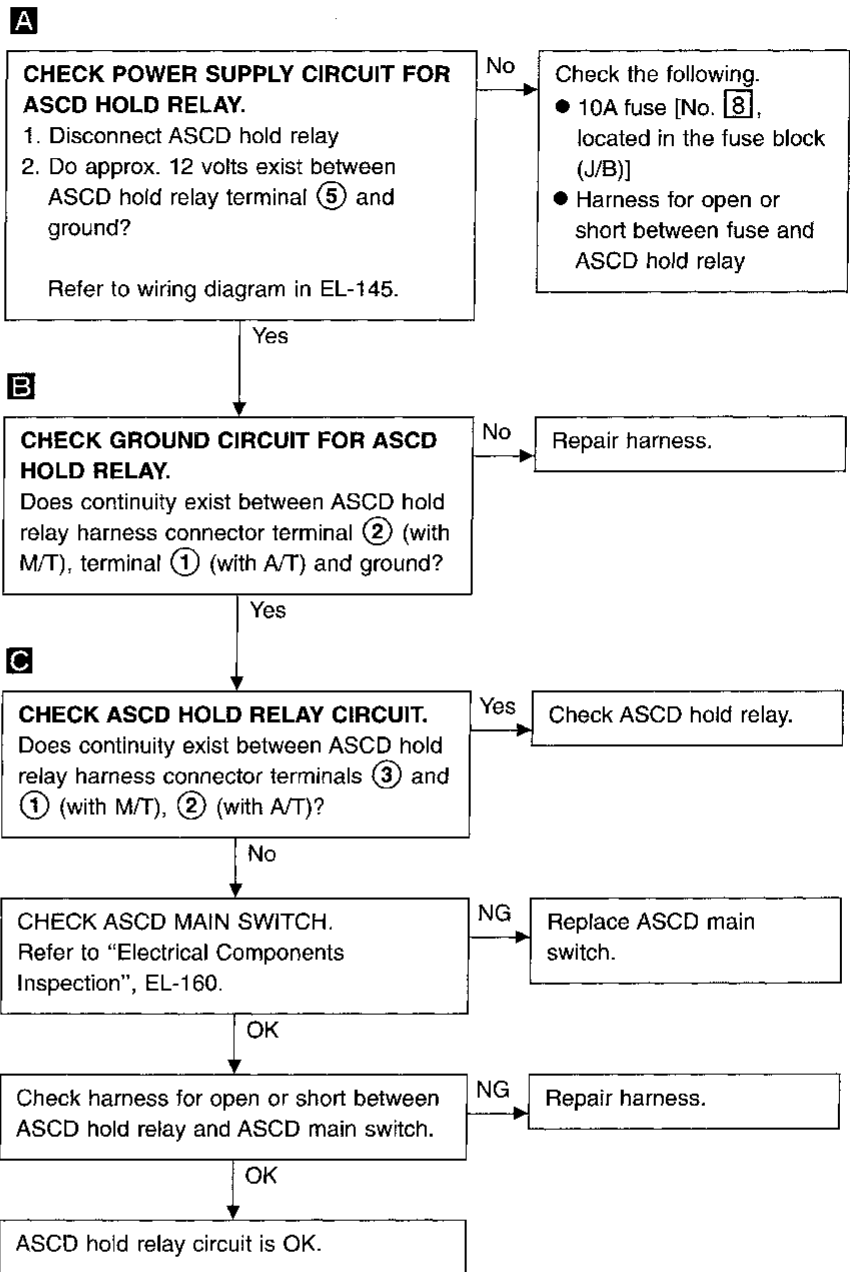
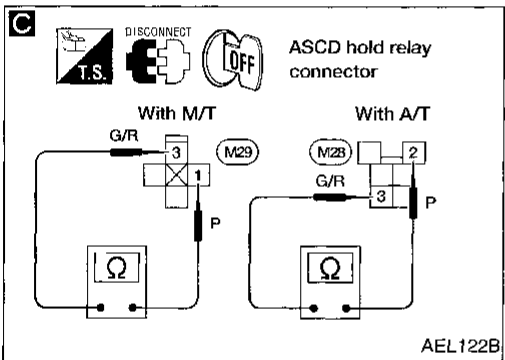
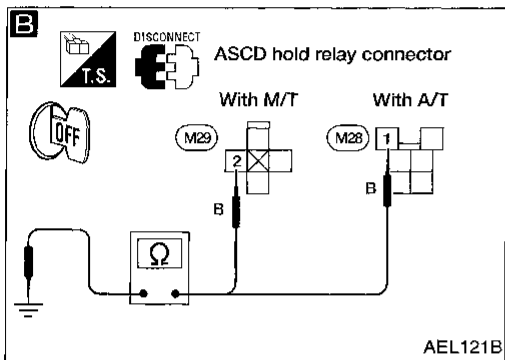
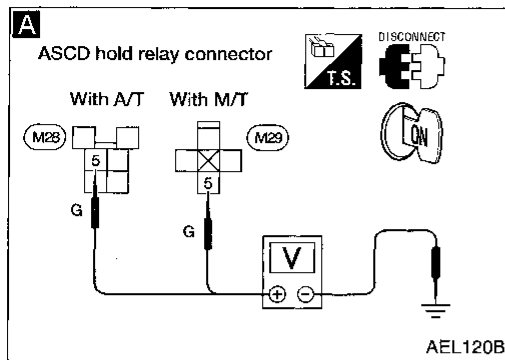

GI
MA
EM
LC
EC
FE
CL
MT
AT
FA
RA
BR
ST
RS
BT
HA
EL
IDX

AUTOMATIC SPEED CONTROL DEVICE (ASCD)

Trouble Diagnoses (Cont'd)

DIAGNOSTIC PROCEDURE 4

(ASCD BRAKE/STOP LAMP SWITCH CHECK)

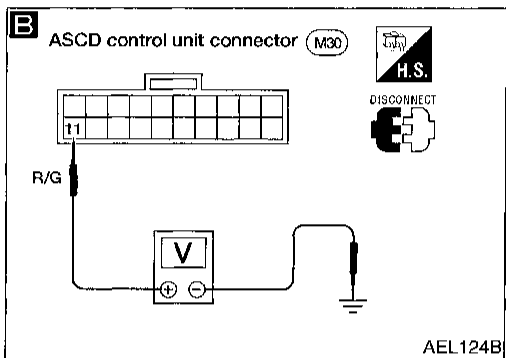
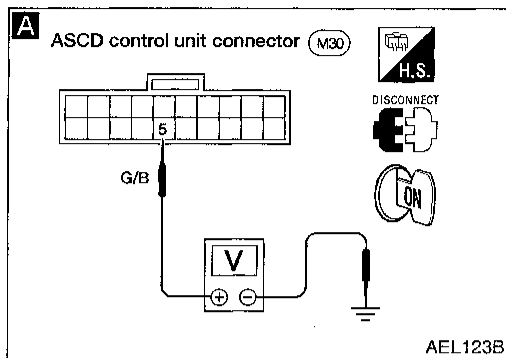

A CHECK ASCD BRAKE SWITCH CIRCUIT.

1. Disconnect control unit connector.
2. Turn ignition switch ON.
3. Turn ASCD main switch "ON".
4. Check voltage between control unit connector terminal (5) and ground. When brake pedal or clutch pedal (M/T) is depressed or A/T selector lever (A/T) is in "N" or "P" range:

Approx. 0V

When brake pedal and clutch pedal (M/T) are released or A/T selector lever (A/T) is not in "N" or "P" range:

Battery voltage should exist.

Refer to wiring diagram in EL-146.

NG

Check the following.

- ASCD brake switch
Refer to "Electrical Components Inspection", EL-160.
- ASCD clutch switch (M/T model)
Refer to "Electrical Components Inspection", EL-160.
- Inhibitor switch (A/T model)
Refer to "Electrical Components Inspection", EL-160.
- ASCD hold relay
- Harness for open or short

OK

B

CHECK STOP LAMP SWITCH CIRCUIT.

1. Disconnect control unit connector.
2. Check voltage between control unit terminal (11) and ground.

Condition		Voltage [V]
Stop lamp switch	Depressed	Approx. 12
	Released	0

Refer to wiring diagram in EL-147.

NG

Check the following.

- 15A fuse [No. 14], located in the fuse block (J/B)]
- Harness for open or short between ASCD control unit and stop lamp switch
- Stop lamp switch
Refer to "Electrical Components Inspection", EL-160.

OK

ASCD brake/stop lamp switch circuit is OK.

AUTOMATIC SPEED CONTROL DEVICE (ASCD)

Trouble Diagnoses (Cont'd)

DIAGNOSTIC PROCEDURE 5

(ASCD STEERING SWITCH CHECK)

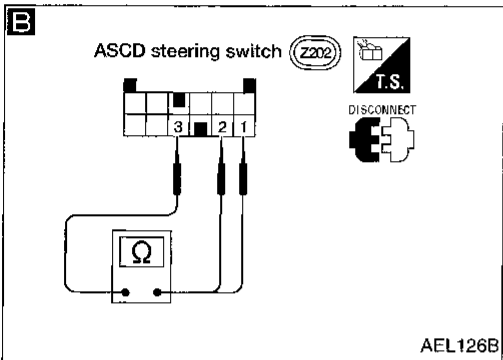
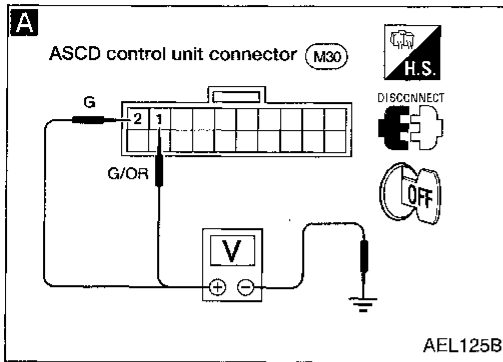

A

CHECK ASCD STEERING SWITCH CIRCUIT FOR ASCD CONTROL UNIT.

1. Disconnect control unit connector.
2. Check voltage between control unit harness terminals and ground.

	Terminal No.		Switch condition	
	⊕	⊖	Pressed	Released
SET/COAST SW	②	Ground	12V	0V
RESUME/ACC SW	①	Ground	12V	0V
CANCEL SW	②	Ground	12V	0V
	①	Ground	12V	0V

Refer to wiring diagram in EL-147.

OK → ASCD steering switch is OK.

NG

CHECK POWER SUPPLY FOR ASCD STEERING SWITCH.
Does horn work?

- NG → Check the following.
- 10A fuse (No. 40, located in the fuse and fusible link box)
 - Horn relay
 - Harness for open or short between horn and fuse

OK

B

CHECK ASCD STEERING SWITCH.

1. Disconnect ASCD steering switch.
2. Check continuity between terminals by pushing each switch.

Switch	Terminal		
	③	②	①
RESUME/ACCEL	○	—	○
SET/COAST	○	○	
CANCEL	○	→ ○	
	○	→	○

NG → Replace ASCD steering switch.

OK

Check harness for open or short between ASCD steering switch and ASCD control unit.

GI
MA
EM
LC
EC
FE
CL
MT
AT
FA
RA
BR
ST
RS
BT
HA
EL
IDX

AUTOMATIC SPEED CONTROL DEVICE (ASCD)

Trouble Diagnoses (Cont'd)

DIAGNOSTIC PROCEDURE 6

(VEHICLE SPEED SENSOR CHECK)

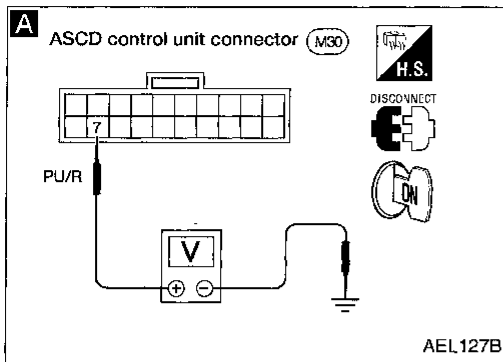

A

CHECK VEHICLE SPEED SENSOR CIRCUIT.

1. Apply wheel chocks and jack up drive wheel.
2. Disconnect control unit connector.
3. Connect voltmeter between control unit terminal ⑦ and ground.
4. Slowly turn drive wheel.
5. Check deflection of voltmeter pointer.

Refer to wiring diagram in EL-148.

OK

Vehicle speed sensor is OK.

NG

Does speedometer operate normally?

No

Check speedometer and vehicle speed sensor circuit. Refer to EL-82.

Yes

Check harness for open or short between ASCD control unit terminal ⑦ and combination meter terminal ⑤.

AUTOMATIC SPEED CONTROL DEVICE (ASCD)

Trouble Diagnoses (Cont'd)

DIAGNOSTIC PROCEDURE 7

(ASCD PUMP CIRCUIT CHECK)

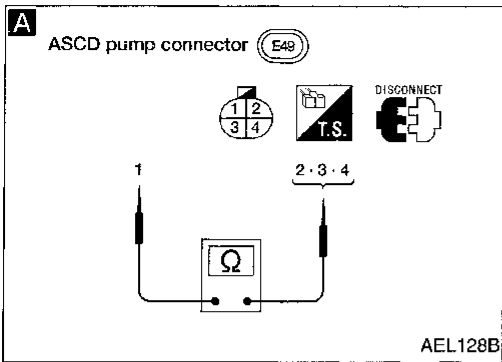

A

CHECK ASCD PUMP.

1. Disconnect ASCD pump connector.
2. Measure resistance between ASCD pump terminals ① and ②, ③, ④.

Terminals	Resistance [Ω]	
①	④	Approx. 11.8
	②	Approx. 67
	③	Approx. 67.3

Refer to wiring diagram in EL-147.

NG

Replace ASCD pump.

OK

Check harness for open or short between ASCD pump and ASCD control unit.

GI

MA

EM

LC

EC

FE

CL

MT

AT

FA

RA

BR

ST

RS

BT

HA

EL

IDX

AUTOMATIC SPEED CONTROL DEVICE (ASCD)

Trouble Diagnoses (Cont'd)

DIAGNOSTIC PROCEDURE 8

(ASCD ACTUATOR/PUMP CHECK)

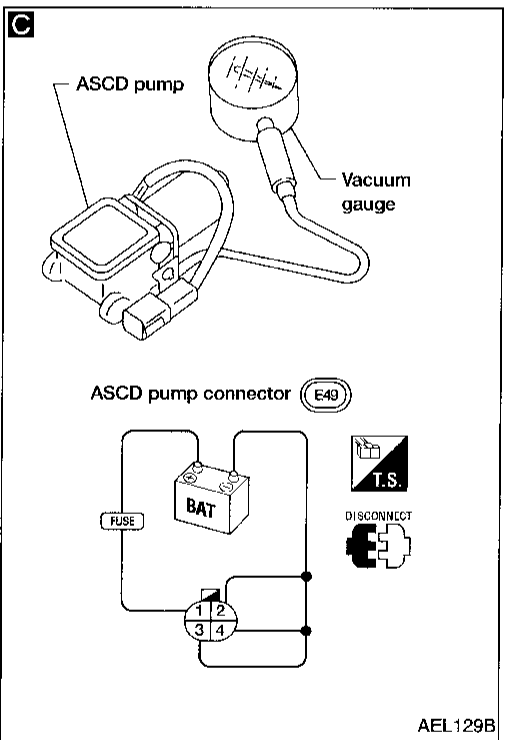
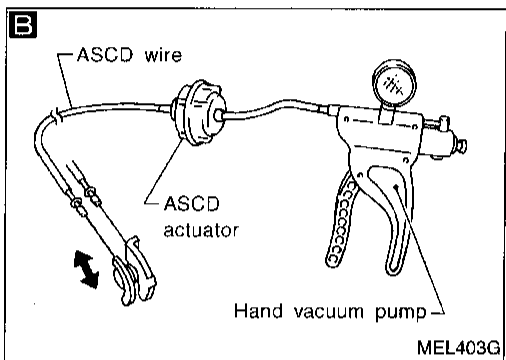
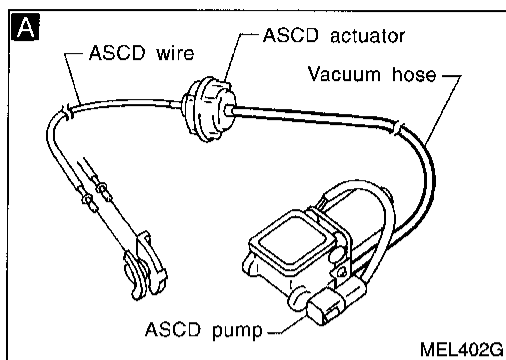

A

CHECK VACUUM HOSE.

Check vacuum hose (between ASCD actuator and ASCD pump) for breakage, cracks or fracture.

NG

Repair or replace hose.

OK

B

CHECK ASCD WIRE.

Check wire for improper installation, rust formation or breaks.

NG

Repair or replace wire. Refer to "ASCD Wire Adjustment", EL-159.

OK

B

CHECK ASCD ACTUATOR.

1. Disconnect vacuum hose from ASCD actuator.
2. Apply -40 kPa (-0.400 bar , -0.41 kg/cm^2 , -5.8 psi) vacuum to ASCD actuator with hand vacuum pump.

ASCD wire should move to pull throttle drum.

3. Wait 10 seconds and check for decrease in vacuum pressure.

Vacuum pressure decrease:

Less than 2.7 kPa (0.0270 bar , 0.028 kg/cm^2 , 0.39 psi)

NG

Replace ASCD actuator.

OK

C

CHECK ASCD PUMP.

1. Disconnect vacuum hose from ASCD pump and ASCD pump connector.
2. If necessary remove ASCD pump.
3. Connect vacuum gauge to ASCD pump.
4. Apply 12V direct current to ASCD pump and check operation.

NG

Replace ASCD pump.

	12V direct current supply terminals		Operation
	⊕	⊖	
Air valve		②	Close
Release valve	①	③	Close
Vacuum motor		④	Operate

A vacuum pressure of at least -35 kPa (-0.350 bar , -0.36 kg/cm^2 , -5.1 psi) should be generated.

OK

INSPECTION END

ASCD Wire Adjustment

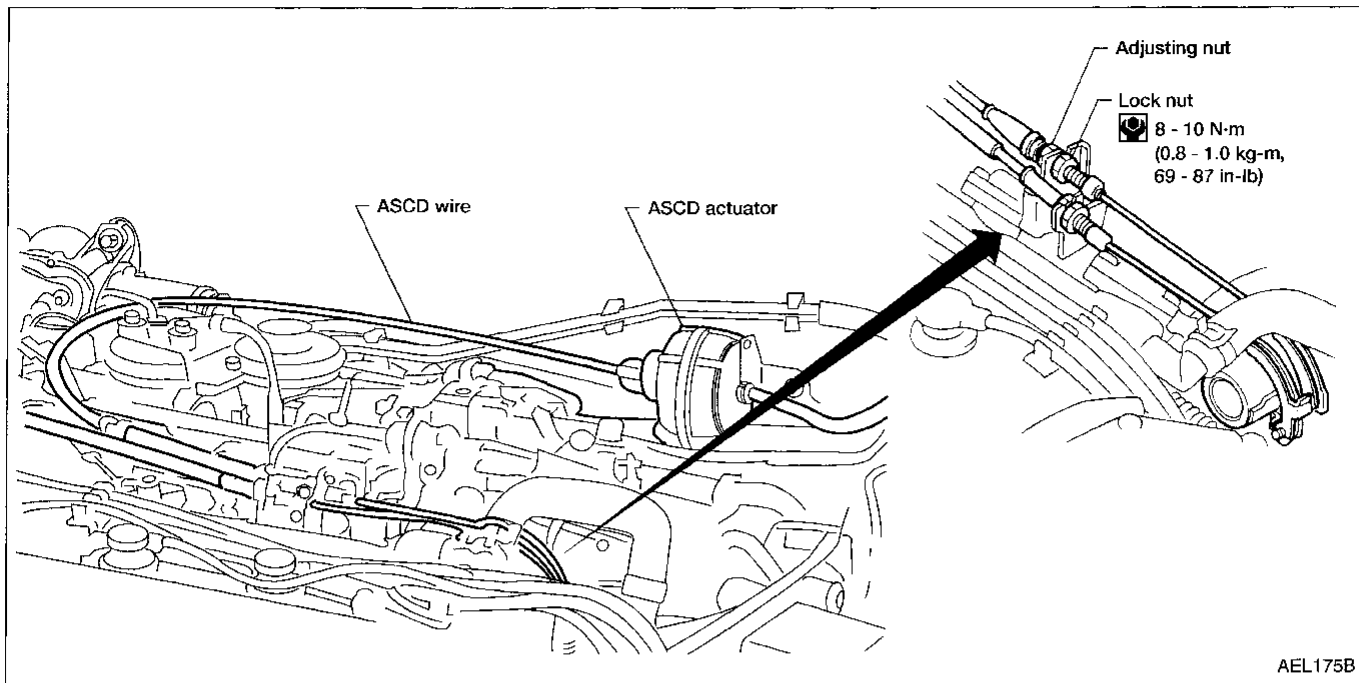

CAUTION:

- Be careful not to twist ASCD wire when removing it.
- Do not tense ASCD wire excessively during adjustment.

Adjust the tension of ASCD wire in the following manner.

- (1) Loosen lock nut and adjusting nut.
- (2) Make sure that accelerator wire is properly adjusted. Refer to FE section ("ACCELERATOR CONTROL SYSTEM").
- (3) Tighten adjusting nut just until throttle drum starts to move.
- (4) Loosen adjusting nut again 1/2 to 1 turn.
- (5) Tighten lock nut.

GI

MA

EM

LC

EC

FE

CL

AEL175B

MT

AT

FA

RA

BR

ST

RS

BT

HA

EL

IDX

AUTOMATIC SPEED CONTROL DEVICE (ASCD)

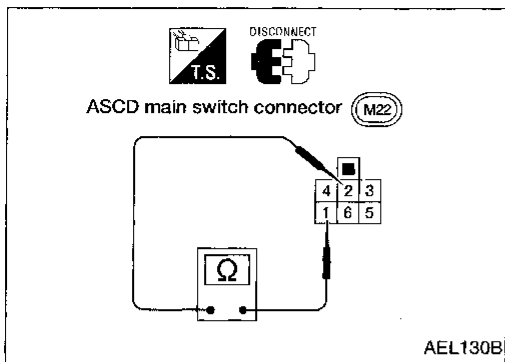

Electrical Components Inspection

ASCD MAIN SWITCH

Check continuity between terminals by pushing switch to each position.

Switch position	Terminals					
	1	2	3	4	5	6
ON	○	○	○	○		
N		○	○	○		
OFF			○	○	○	○

ILL. (Interlock) is shown between terminals 5 and 6.

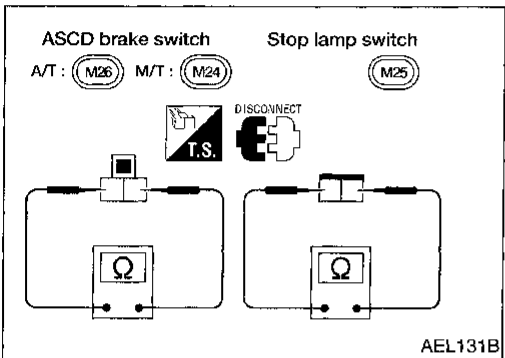

ASCD BRAKE SWITCH AND STOP LAMP SWITCH

Condition	Continuity	
	ASCD brake switch	Stop lamp switch
When brake pedal is depressed	No	Yes
When brake pedal is released	Yes	No

Check each switch after adjusting brake pedal — refer to BR section.

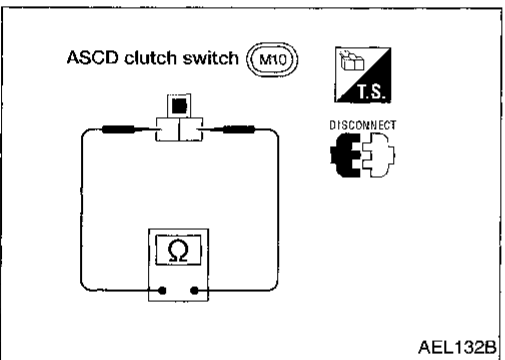

ASCD CLUTCH SWITCH (For M/T models)

Condition	Continuity
When clutch pedal is depressed	No
When clutch pedal is released	Yes

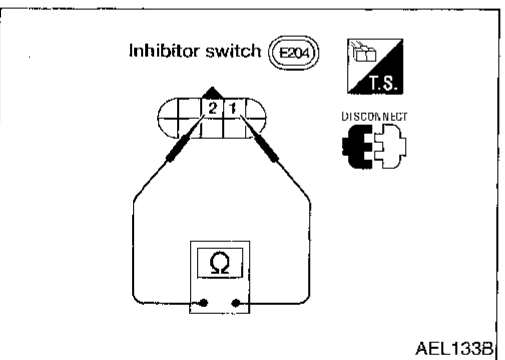

INHIBITOR SWITCH (For A/T models)

A/T selector lever position	Continuity
	Between terminals ① and ②
"P"	Yes
"N"	Yes
Except "P" and "N"	No

System Description

Power is supplied at all times:

- from 40A fusible link (Letter **d**), located in the fuse and fusible link box
- to circuit breaker-1 terminal **①**
- through circuit breaker-1 terminal **②**
- to power window relay terminal **③**.

GI

MA

EM

LC

EC

FE

CL

MT

AT

FA

RA

BR

ST

RS

BT

HA

EL

IDX

With ignition switch in ON or START position, power is supplied:

- through 10A fuse [No. **8**] located in the fuse block (J/B)
- to power window relay terminal **①**.

Ground is supplied to power window relay terminal **②**:

- through body grounds **(M2)** and **(M61)**.

The power window relay is energized and power is supplied:

- through power window relay terminal **⑤**
- to main power window and door lock/unlock switch terminal **②**,
- to power window switches terminal **③**.

MANUAL OPERATION

Front door LH

Ground is supplied:

- to main power window and door lock/unlock switch terminal **⑩**
- through body grounds **(M2)** and **(M61)**.

WINDOW UP

When the front LH switch in the main power window and door lock/unlock switch is pressed in the up position, power is supplied:

- to front power window motor LH terminal **②**
- through power window main switch terminal **⑫**.

Ground is supplied:

- to front power window motor LH terminal **①**
- through power window main switch terminal **⑫**.

Then, the motor raises the window until the switch is released.

WINDOW DOWN

When the LH switch in the main power window and door lock/unlock switch is pressed in the down position, power is supplied:

- to front power window motor LH terminal **①**
- through power window main switch terminal **⑫**.

Ground is supplied:

- to front power window motor LH terminal **②**
- through power window main switch terminal **⑫**.

Then, the motor lowers the window until the switch is released.

Front door RH

Ground is supplied:

- to main power window and door lock/unlock switch terminal **⑩**
- through body grounds **(M2)** and **(M61)**.

NOTE:

Numbers in parentheses are terminal numbers, when power window switch is pressed in the UP and DOWN positions respectively.

MAIN SWITCH OPERATION

Power is supplied:

- through main power window and door lock/unlock switch (**⑭**, **⑬**)
- to front power window switch RH (**②**, **④**).

The subsequent operation is the same as the power window switch operation.

POWER WINDOW

System Description (Cont'd)

POWER WINDOW SWITCH OPERATION

Power is supplied:

- to front power window switch (②, ④)
- through front power window switch (⑤, ⑥)
- to front power window motor RH (①, ②).

Ground is supplied:

- to front power window motor RH (①, ②)
- to front power window switch (⑤, ⑥)
- through front power window switch (②, ④)
- through power window main switch (⑬, ⑭).

Then, the motor raises or lowers the window until the switch is released.

Rear door

Rear door windows will rise and lower in the same manner as front door RH window.

AUTO OPERATION

The power window AUTO feature enables the driver to lower the driver's window without holding the window switch in the down position.

The AUTO feature only operates on the driver's window downward movement.

POWER WINDOW LOCK

The power window lock is designed to lock operation of all windows except for driver's door window. When the lock switch is pressed to lock position, ground of the power window switches in the main power window and door lock/unlock switch is disconnected. This prevents the power window motors from operating.

POWER WINDOW

NOTES

GI

MA

EM

LC

EC

FE

CL

MT

AT

FA

RA

BR

ST

RS

BT

HA

EL

IDX

POWER WINDOW

Wiring Diagram — WINDOW —

EL-WINDOW-01

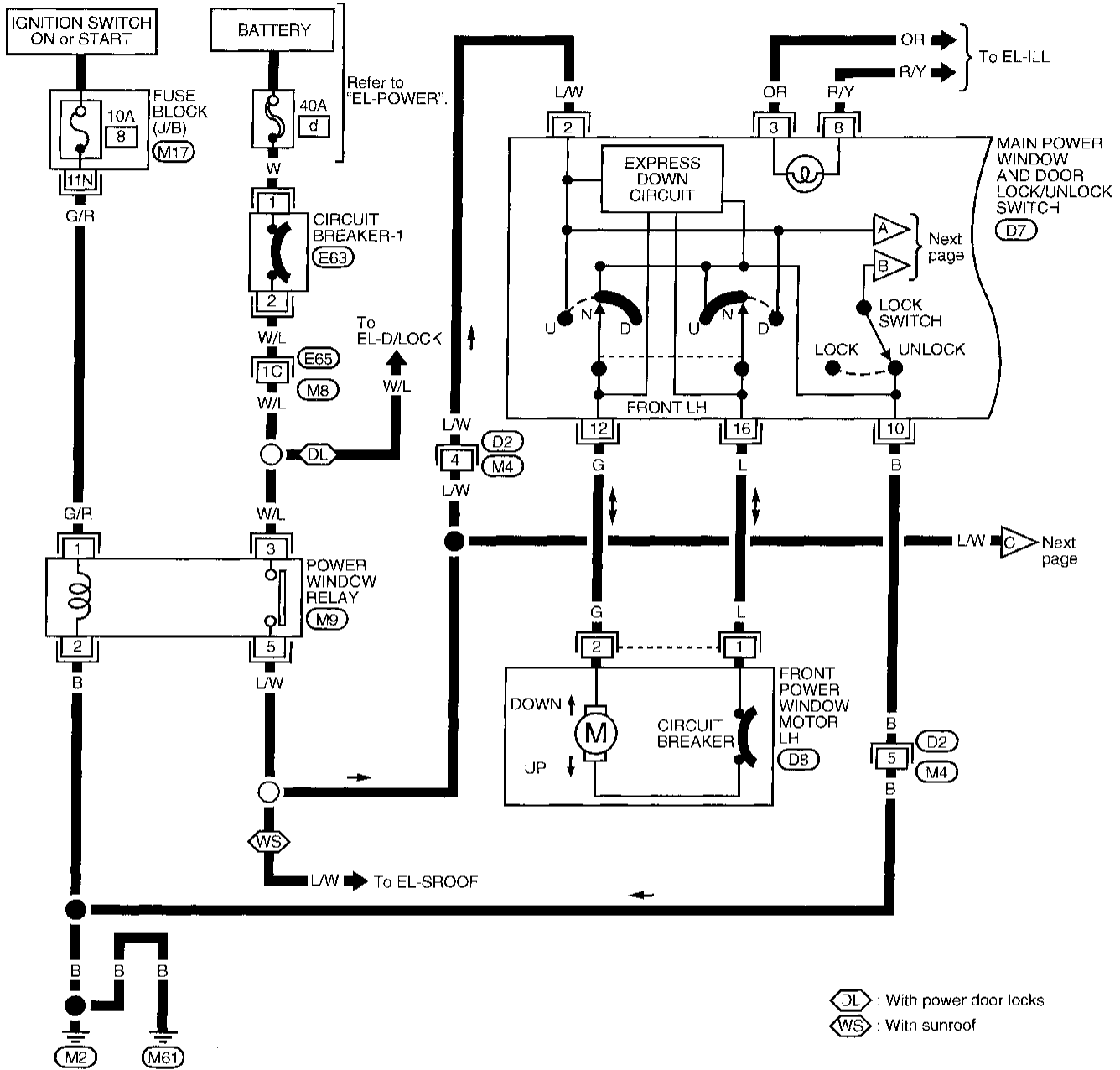

DL : With power door locks
WS : With sunroof

Refer to last page (Foldout page).

M8, E65

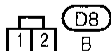
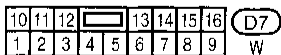
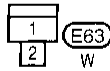
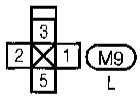

POWER WINDOW

Wiring Diagram — WINDOW — (Cont'd)

EL-WINDOW-02

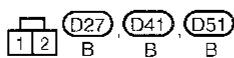
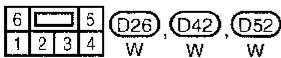
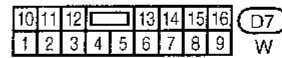
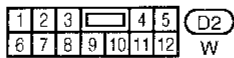
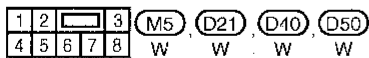
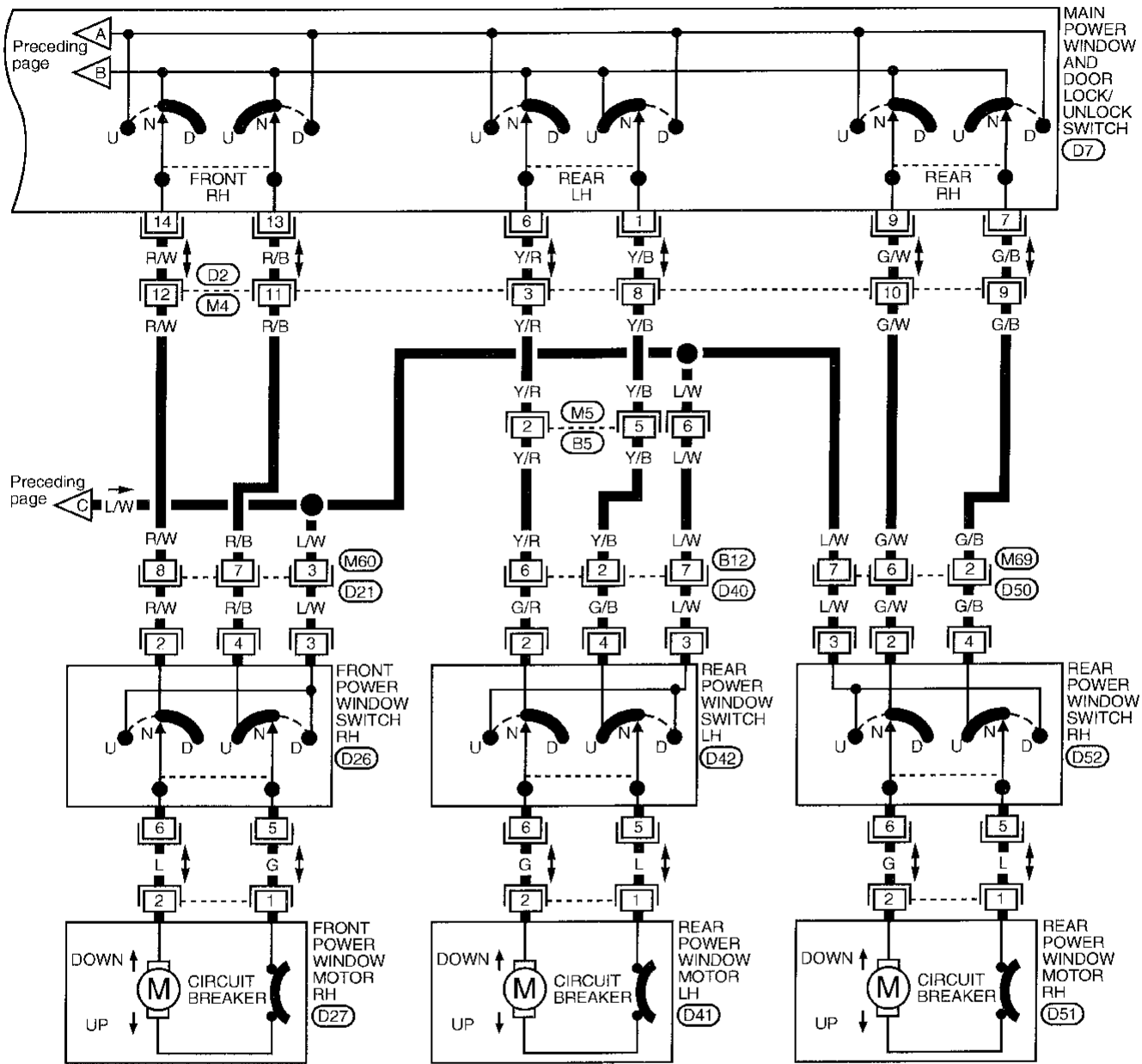

GI

MA

EM

LC

EC

FE

CL

MT

AT

FA

RA

BR

ST

RS

BT

HA

EL

IDX

POWER WINDOW

Trouble Diagnoses

Symptom	Possible cause	Repair order
None of the power windows can be operated using any switch.	<ol style="list-style-type: none"> 1. 10A fuse, 40A fusible link and E63 circuit breaker 2. Grounds M2 and M61 3. Power window relay 4. Open/short in main power window switch circuit 	<ol style="list-style-type: none"> 1. Check 10A fuse (No. 8), located in fuse block [J/B]), 40A fusible link (letter d), located in fuse and fusible link box) and E63 circuit breaker. Turn ignition switch ON and verify battery positive voltage is present at terminal 2 of main power window switch and terminal 3 of passenger switches. 2. Check grounds M2 and M61. 3. Check power window relay. 4. Check L/W wire between power window relay and main power window switch for open/short circuit.
Driver side power window cannot be operated but other windows can be operated.	<ol style="list-style-type: none"> 1. Driver side power window motor circuit 2. Driver side power window motor 	<ol style="list-style-type: none"> 1. Check harness between main power window switch and front power window motor LH for open or short circuit. 2. Check front power window motor LH.
Passenger power window cannot be operated.	<ol style="list-style-type: none"> 1. Passenger power window switch 2. Passenger power window motor 3. Main power window switch 4. Power window circuit 	<ol style="list-style-type: none"> 1. Check passenger power window switch. 2. Check passenger power window motor. 3. Check main power window switch. 4-1. Check harnesses between main power window switch and passenger power window switch for open/short circuit. 4-2. Check harnesses between passenger power window switch and passenger power window motor for open/short circuit.
Passenger power window cannot be operated using main power window switch but can be operated by passenger power window switch.	<ol style="list-style-type: none"> 1. Main power window switch 	<ol style="list-style-type: none"> 1. Check main power window switch.
Driver side power window auto function cannot be operated using main power window switch.	<ol style="list-style-type: none"> 1. Main power window switch 	<ol style="list-style-type: none"> 1. Check main power window switch.

Passenger refers to front RH, or rear LH or RH.

POWER DOOR LOCK

Component Parts and Harness Connector Location

GI

MA

EM

LC

EC

FE

CL

MT

AT

FA

RA

BR

ST

RS

BT

HA

EL

IDX

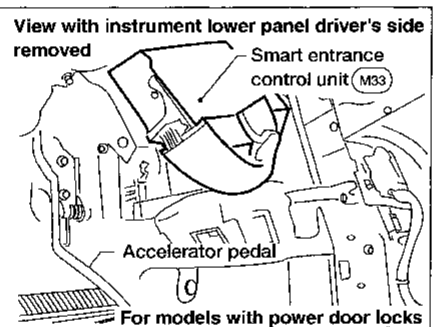
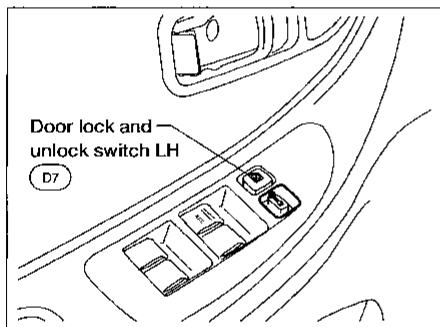
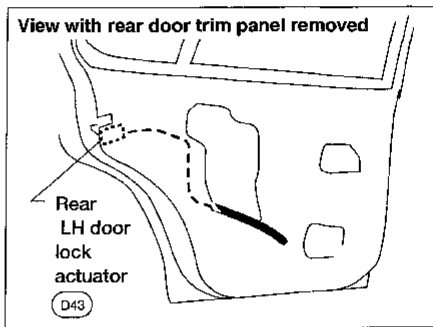
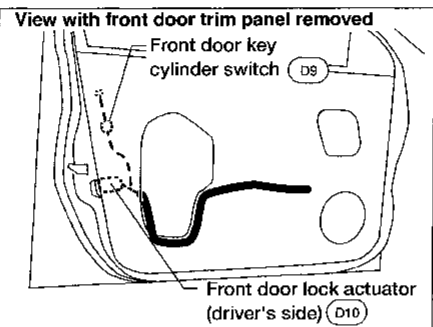
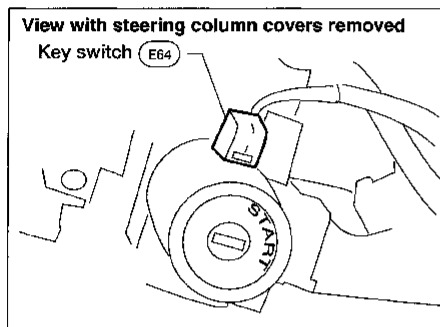
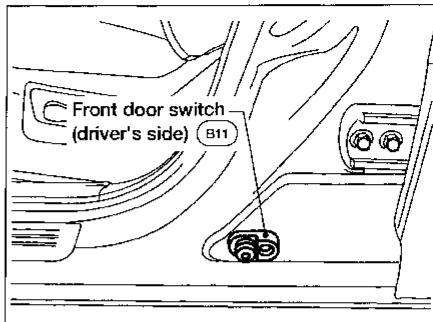
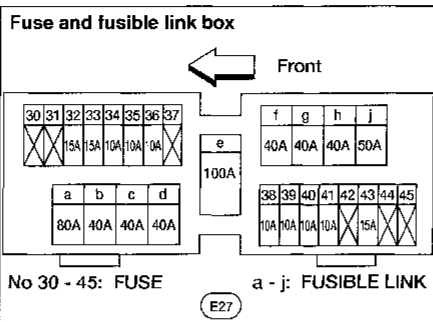
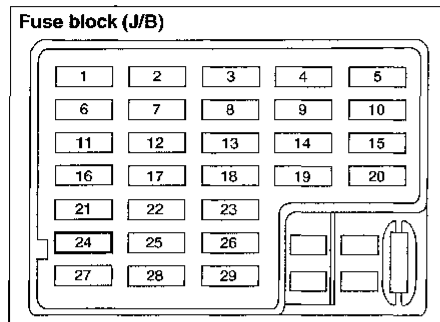

POWER DOOR LOCK

System Description

Power is supplied at all times:

- through 40A fusible link (Letter **d**), located in the fuse and fusible link box)
- to circuit breaker-1 terminal ①
- through circuit breaker-1 terminal ②
- to smart entrance control unit terminal ①.

Power is supplied at all times:

- through 10A fuse [No. **24**], located in the fuse block (J/B)]
- to key switch terminal ②.

Ground is supplied:

- to smart entrance control unit terminal ⑩
- through body grounds **M2** and **M61** .

INPUT

Power is supplied through key switch terminal ① to smart entrance control unit terminal ②④ when the ignition key is inserted in the key switch.

Ground is supplied:

- to smart entrance control unit terminal ⑮ or ⑳
- through front LH or RH door switch terminal ① when front LH or RH door is open.

Ground is supplied:

- to smart entrance control unit terminal ⑳
- from front LH door key cylinder switch terminal ③ or RH door key cylinder switch terminal ①.
- through front LH or RH door key cylinder switch terminal ② when door key cylinder is BETWEEN FULL STROKE AND N position
- through body grounds **M2** and **M61** .

Ground is supplied:

- to smart entrance control unit terminal ⑫ or ⑬
- from door unlock sensor (in the front LH or RH door lock actuator) terminal ④ when door lock is in UNLOCKED position
- through door unlock sensor (in the front LH or RH door lock actuator) terminal ②
- through body grounds **M2** and **M61** .

Ground is supplied:

- to smart entrance control unit terminal ⑲ or ⑱
- from main power window and door lock/unlock switch terminal ⑪ or ⑮
- through main power window and door lock/unlock switch terminal ⑩ (when switch is pressed in lock or unlock position)
- through body grounds **M2** and **M61** .

OUTPUT

Unlock

Power is supplied:

- from smart entrance control unit terminal ③ (with multi-remote control system) or terminal ② (without multi-remote control system)
- to front LH door lock actuator terminal ①.

Power is supplied:

- from smart entrance control unit terminal ②
- to front RH door lock actuator or rear door lock actuator terminals ①.

Ground is supplied:

- from smart entrance control unit terminal ④
- to all door actuator terminals ③.

With power and ground supplied, the door actuators move to the unlocked position.

POWER DOOR LOCK

System Description (Cont'd)

Lock

Power is supplied:

- from smart entrance control unit terminal ④
- to all door actuator terminals ③.

Ground is supplied:

- from smart entrance control unit terminal ③ (with multi-remote control system) or terminal ② (without multi-remote control system)
- to front LH door lock actuator terminal ①.

Ground is supplied:

- from smart entrance control unit terminal ②
- to RH door lock actuator or rear door lock actuator terminals ①.

With power and ground supplied, the door actuators move to the locked position.

OPERATION

- The lock and unlock switch on driver's door trim can lock and unlock all doors.
- With the lock knob on front LH or RH door set to LOCKED, all doors are locked (signal from door unlock sensor).
- With the door key inserted in the key cylinder on front LH or RH door, turning it to LOCK will lock all doors; turning it to UNLOCK once unlocks the corresponding door; turning it to UNLOCK again within 5 seconds after the first unlock operation unlocks all of the other doors (signal from front door key cylinder switch).

However, if the ignition key is in the ignition key cylinder and one or more of the front doors are open, setting the lock and unlock switch, lock knob, or the door key to LOCK locks the doors once but then immediately unlocks them (combination signals from key switch, front LH or RH door switch and front LH or RH door unlock sensor). — (KEY REMINDER DOOR SYSTEM)

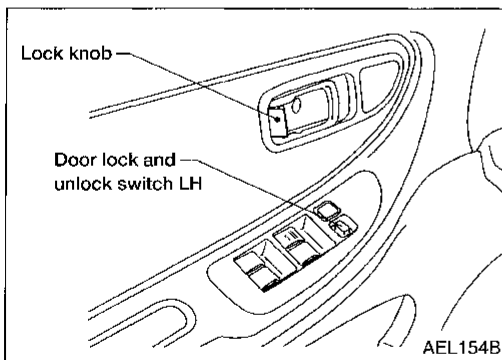

GI

MA

EM

LC

EC

FE

CL

MT

AT

FA

RA

BR

ST

RS

BT

HA

EL

IDX

POWER DOOR LOCK

Schematic

RE : With multi-remote control system
OE : Without multi-remote control system

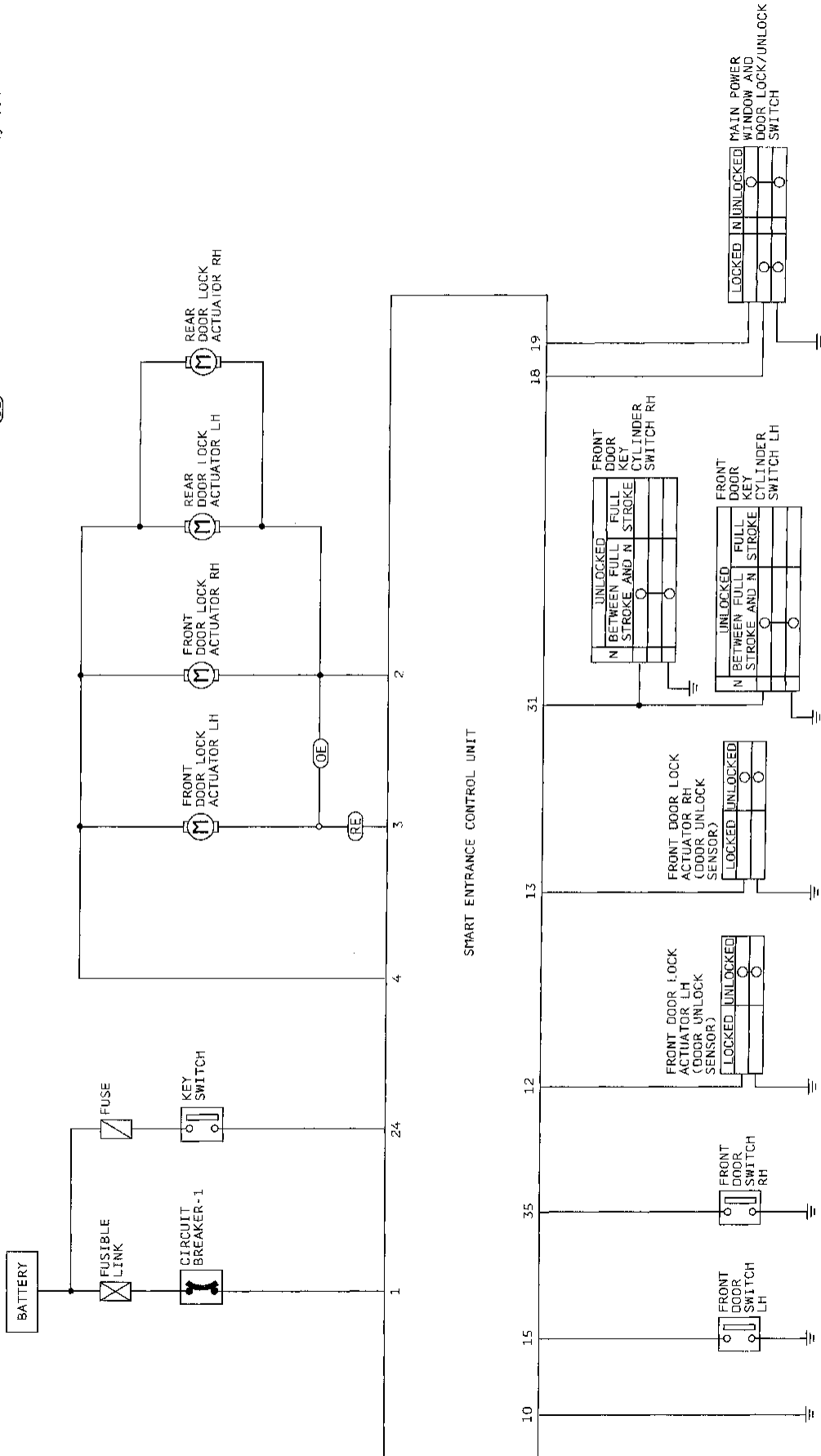

POWER DOOR LOCK

Wiring Diagram — D/LOCK —

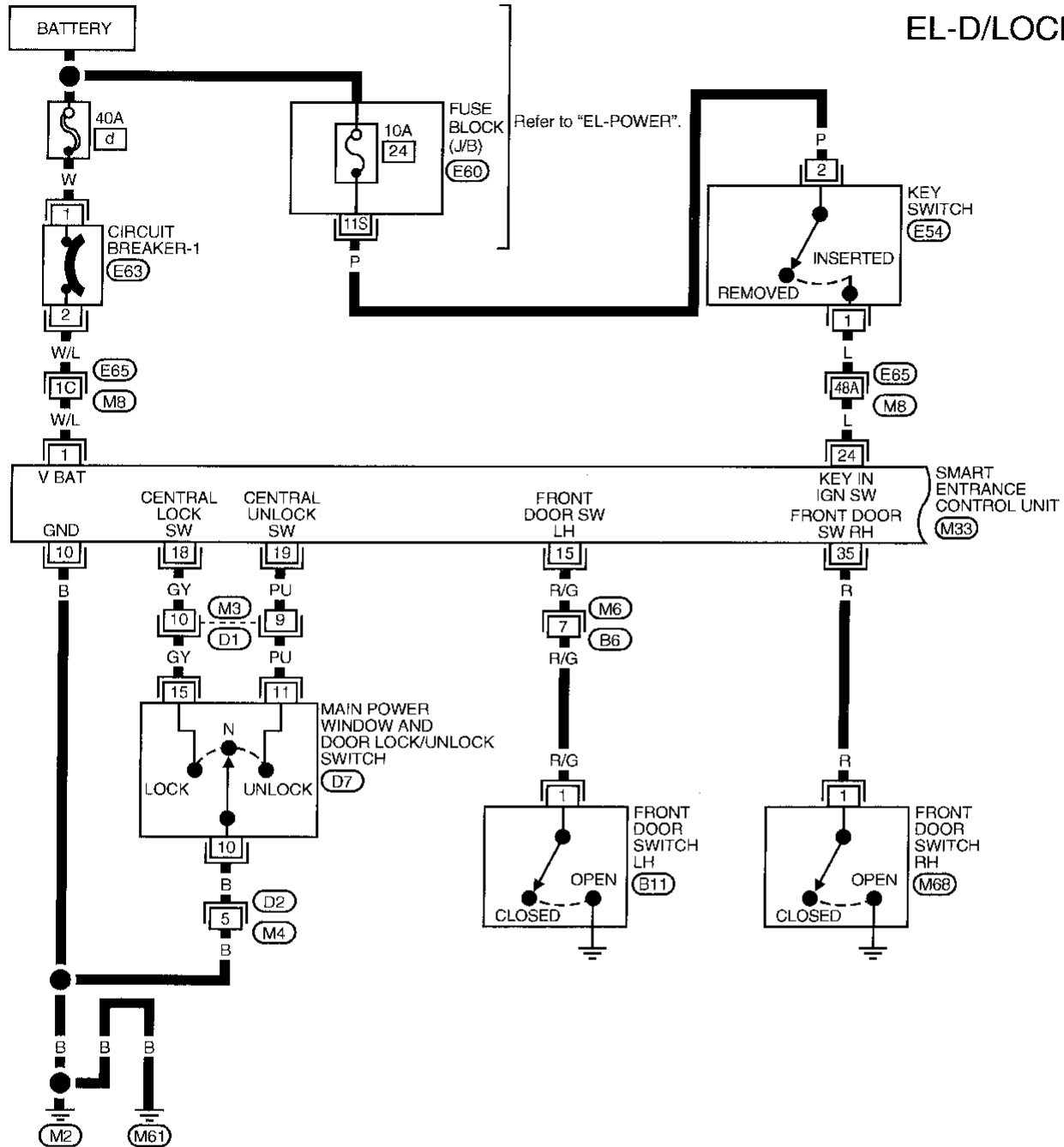

GI
MA
EM
LC
EC
FE
CL
MT
AT
FA
RA
BR
ST
RS
BT

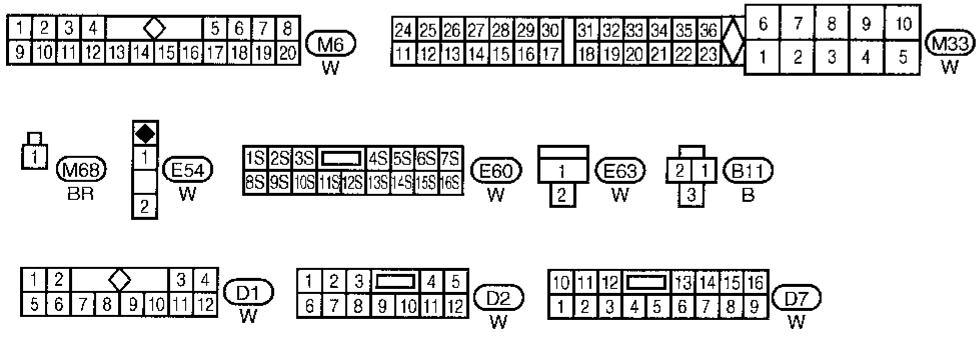

HA
EL
IDX

POWER DOOR LOCK

Wiring Diagram — D/LOCK — (Cont'd)

EL-D/LOCK-02

RE : With multi-remote control system
 OE : Without multi-remote control system

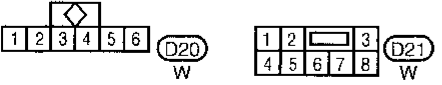
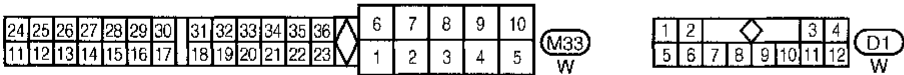
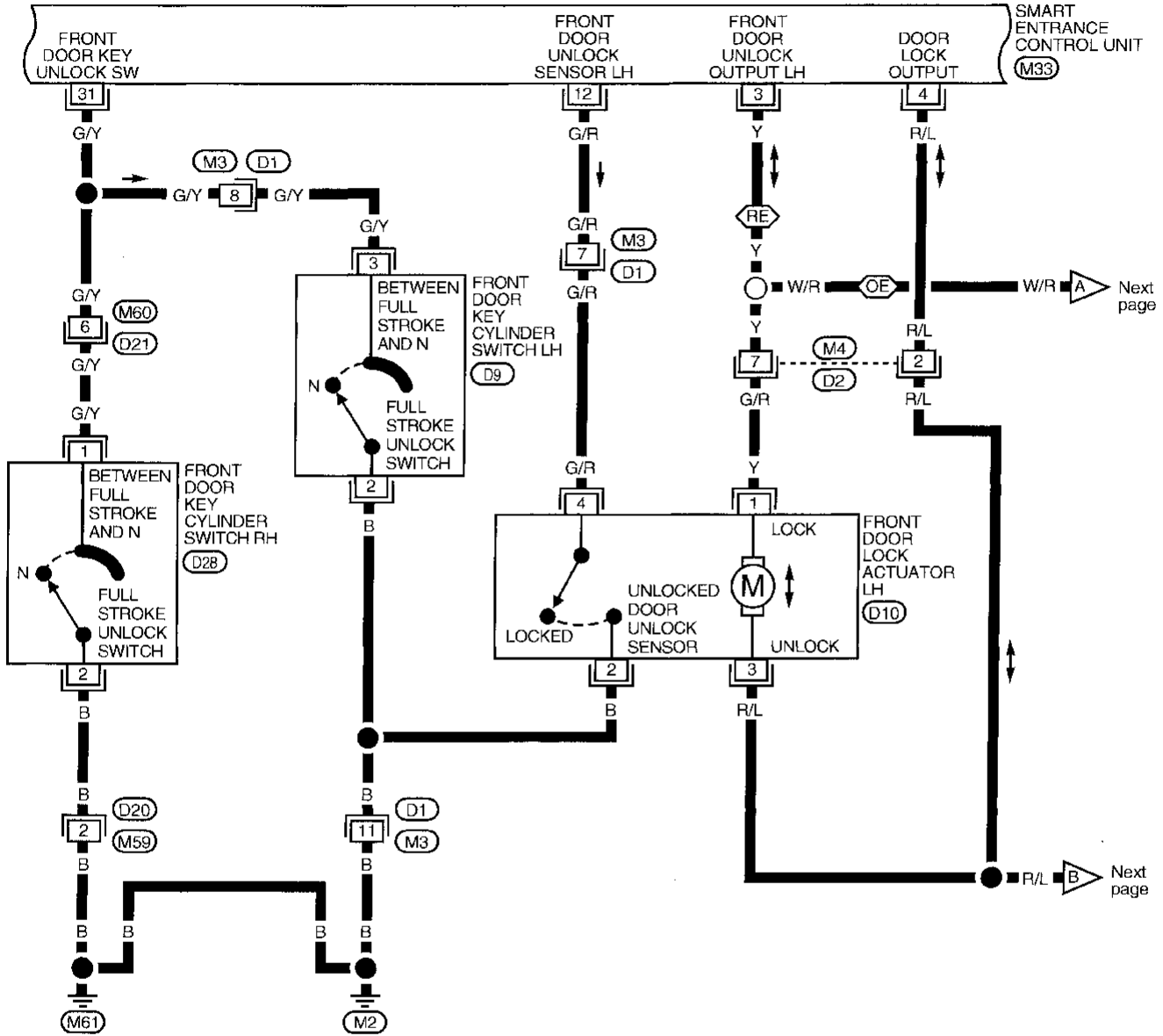

POWER DOOR LOCK

Wiring Diagram — D/LOCK — (Cont'd)

EL-D/LOCK-03

: Without multi-remote control system

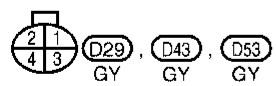
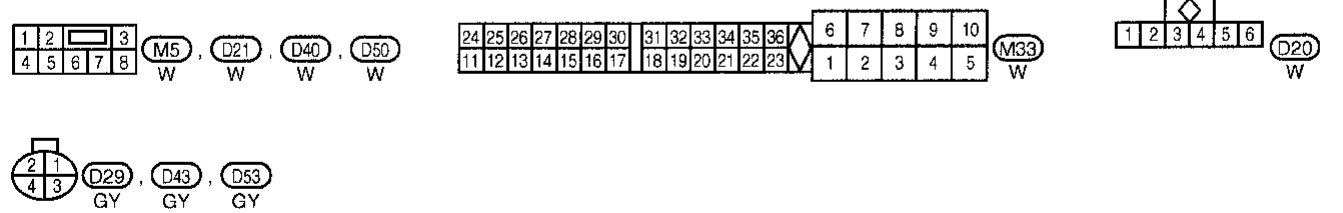
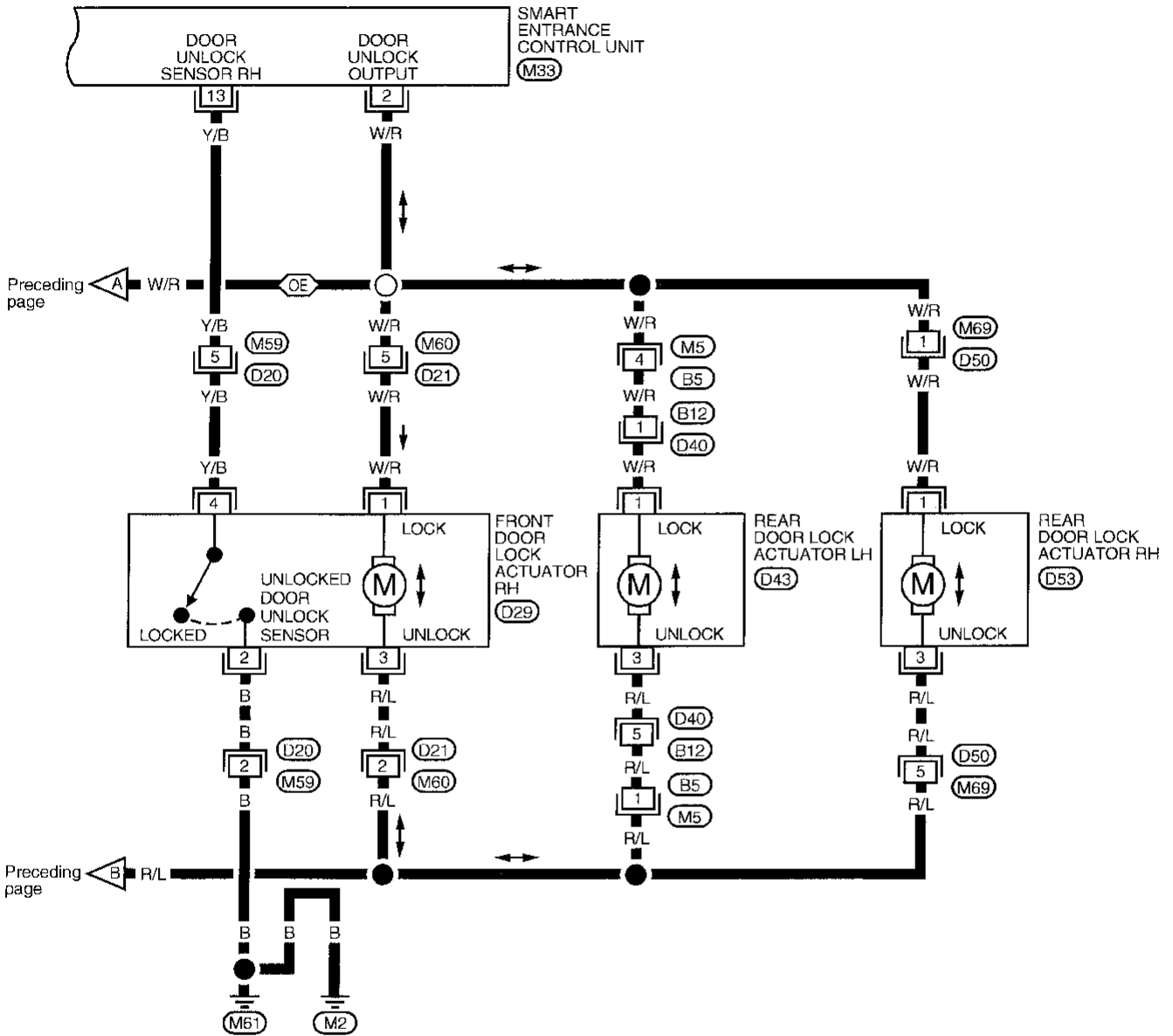

GI
MA
EM
LC
EC
FE
CL
MT
AT
FA
RA
BR
ST
RS
BT
HA
EL
IDX

POWER DOOR LOCK

Trouble Diagnoses

SYMPTOM CHART

PROCEDURE	Main power supply and ground circuit check		Diagnostic procedure					
	EL-175	EL-175	EL-211	EL-177	EL-178	EL-216	EL-215	EL-181
SYMPTOM	Main power supply for door lock control unit	Ground circuit for door lock control unit	Procedure 1 (Front door switch check)	Procedure 2 [Key switch (insert) check]	Procedure 3 (Lock/unlock switch check)	Procedure 4 (Front door key cylinder switch check)	Procedure 5 (Front door unlock sensor check)	Procedure 6 (Door lock actuator check)
Key reminder door system does not operate properly.	X	X	X	X			X	X
One or more doors are not locked and/or unlocked.	X	X					X	X
Lock & unlock switch does not operate.	X	X			X			
None of the doors lock/unlock when operating front door key cylinder switch.	X	X				X		
None of the doors lock when operating front door knob lock switch.	X	X					X	

Perform "Main Power Supply and Ground Circuit Check" before starting with power door lock diagnostic procedure.

POWER DOOR LOCK

Trouble Diagnoses (Cont'd)

MAIN POWER SUPPLY AND GROUND CIRCUIT CHECK

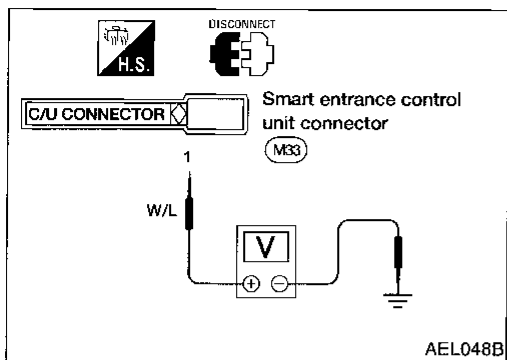

Main power supply circuit check

Terminal		Ignition switch		
⊕	⊖	OFF	ACC	ON
①	Ground	Battery voltage	Battery voltage	Battery voltage

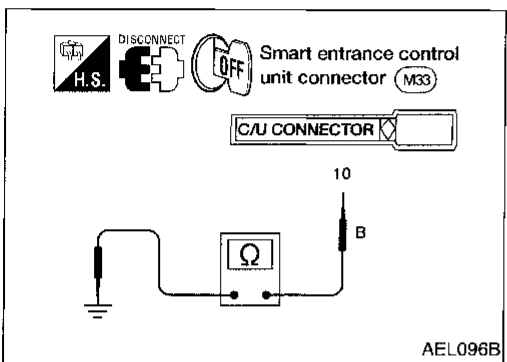

Ground circuit check

Terminals	Continuity
⑩ - Ground	Yes

GI
MA
EM
LC
EC
FE
CL
MT
AT
FA
RA
BR
ST
RS
BT
HA
EL
IDX

POWER DOOR LOCK

Trouble Diagnoses (Cont'd)

DIAGNOSTIC PROCEDURE 1 (Front door switch check)

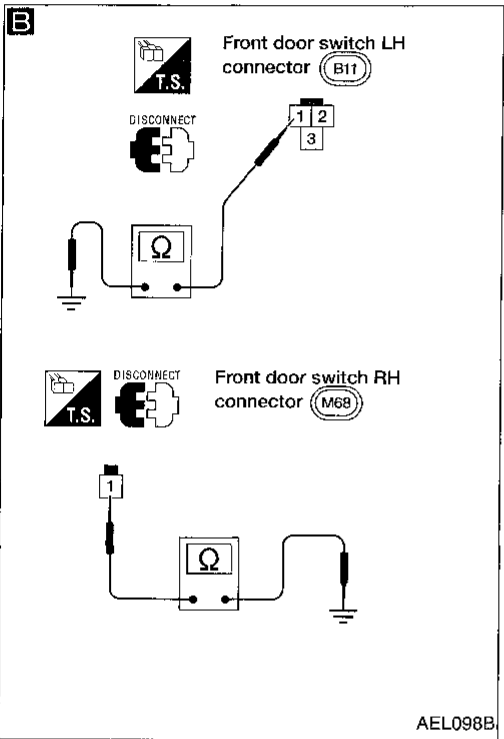
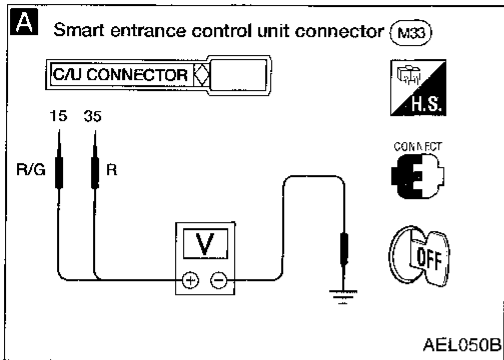

A

CHECK DOOR SWITCH INPUT SIGNAL.
Check voltage between control unit terminals ⑮ or ⑳ and ground.

	Terminals		Condition	Voltage [V]
	⊕	⊖		
Front LH door switch	⑮	Ground	Open	0
			Closed	Approx. 12
Front RH door switch	⑳	Ground	Open	0
			Closed	Approx. 12

Refer to wiring diagram in EL-171.

OK → Door switch is OK.

NG

B

CHECK DOOR SWITCH.
1. Disconnect door switch connector.
2. Check continuity between door switch terminals.

	Terminals	Condition	Continuity
Front LH door switch	① - Ground	Closed	No
		Open	Yes
Front RH door switch	① - Ground	Closed	No
		Open	Yes

NG → Replace door switch.

OK

Check the following.

- Door switch ground circuit (Front LH) or door switch ground condition
- Harness for open or short between control unit and door switch

POWER DOOR LOCK

Trouble Diagnoses (Cont'd)

DIAGNOSTIC PROCEDURE 2

[Key switch (insert) check]

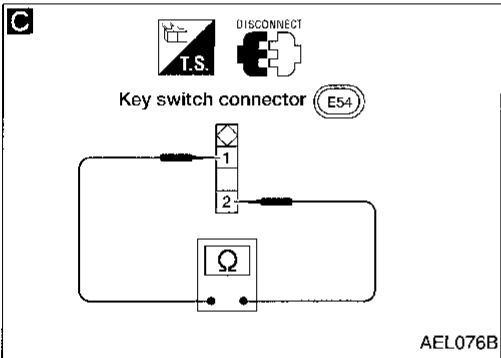
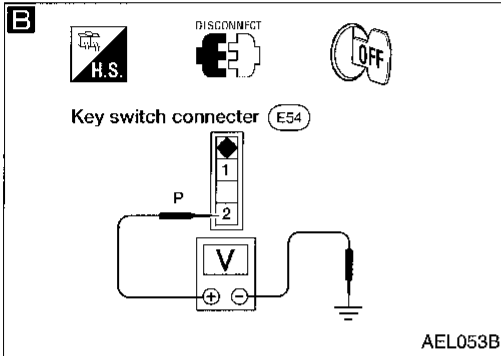
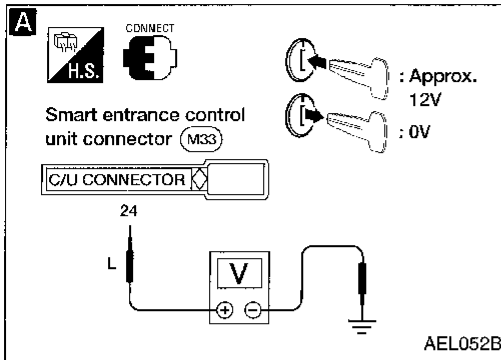

A

CHECK KEY SWITCH INPUT SIGNAL.

Check voltage between control unit terminal (24) and ground.

Condition of key switch	Voltage [V]
Key is inserted.	Approx. 12
Key is withdrawn.	0

Refer to wiring diagram in EL-171.

OK → Key switch (insert) is ok.

NG

B

CHECK KEY SWITCH POWER SUPPLY.

1. Disconnect key switch connector.
2. Check voltage between key switch harness terminal (2) and ground.

Battery voltage should exist.

NG → Check the following.

- 10A fuse [No. 24], located in fuse block (J/B)
- Harness for open or short between key switch and fuse

OK

C

CHECK KEY SWITCH.

Check continuity between key switch terminals.

Terminals	Condition	Continuity
(1) - (2)	Key is inserted.	Yes
	Key is withdrawn.	No

NG → Replace key switch.

OK

Check harness for open or short between control unit and key switch.

GI

MA

EM

LC

EC

FE

CL

WT

AT

FA

FA

BR

ST

RS

BT

HA

EL

IDX

POWER DOOR LOCK

Trouble Diagnoses (Cont'd)

DIAGNOSTIC PROCEDURE 3

(Door lock/unlock switch check)

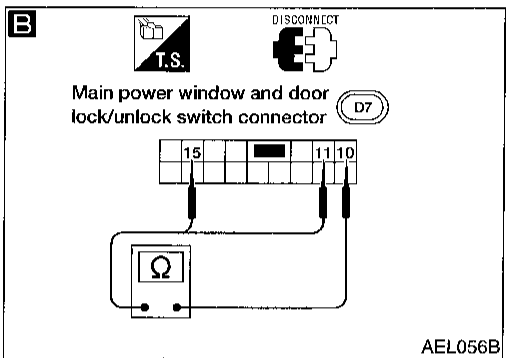
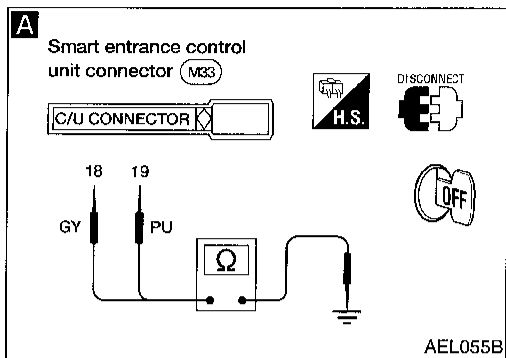

A

CHECK DOOR LOCK/UNLOCK SWITCH INPUT SIGNAL.

1. Disconnect control unit connector.
2. Check continuity between control unit terminal (18) or (19) and ground.

Terminals	Door lock/unlock switch (LH or RH) condition	Continuity
(18) - Ground	Lock	Yes
	N and Unlock	No
(19) - Ground	Unlock	Yes
	N and Lock	No

Refer to wiring diagram in EL-171.

OK → Door lock/unlock switch is OK.

B

CHECK DOOR LOCK/UNLOCK SWITCH.

1. Disconnect main power window and door lock/unlock switch connector.
2. Check continuity between main power window and door lock/unlock switch terminals.

Condition	Terminals		
	10	11	15
Lock	○	○	○
N	No continuity		
Unlock	○	○	

NG → Replace main power window and door lock/unlock switch.

OK

Check the following.

- Ground circuit for door lock/unlock switch
- Harness for open or short between door lock/unlock switch and control unit connector

POWER DOOR LOCK

Trouble Diagnoses (Cont'd)

DIAGNOSTIC PROCEDURE 4

(Front door key cylinder switch check)

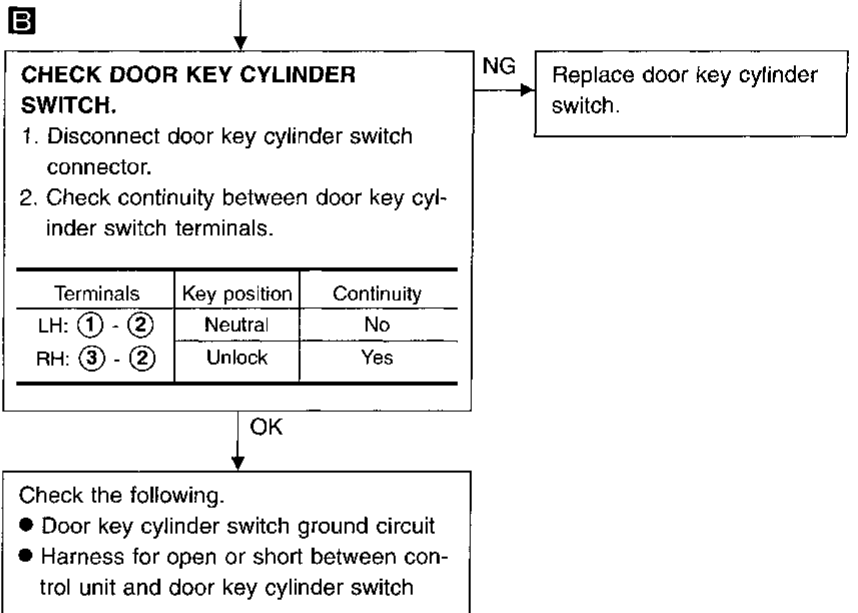
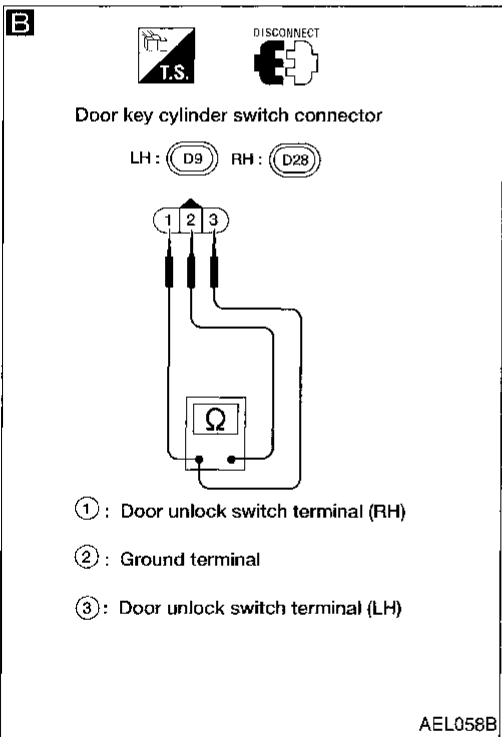
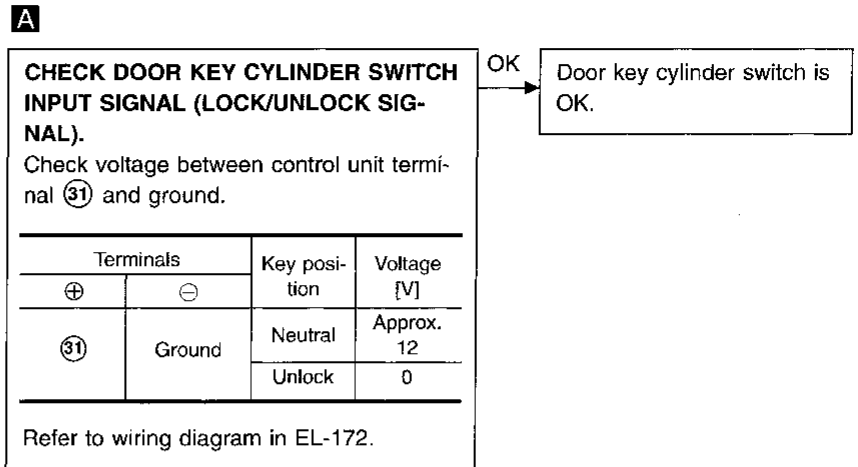
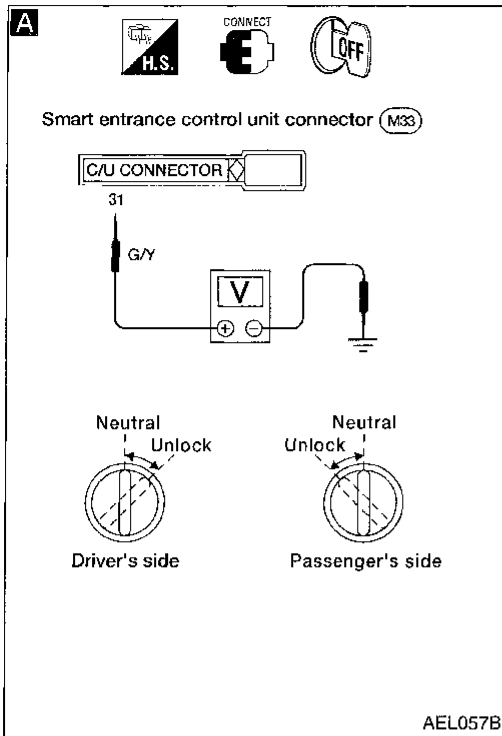

GI

MA

EM

LC

EC

FE

CL

MT

AT

FA

RA

BR

ST

RS

BT

HA

EL

IDX

POWER DOOR LOCK

Trouble Diagnoses (Cont'd)

DIAGNOSTIC PROCEDURE 5 (Front door unlock sensor check)

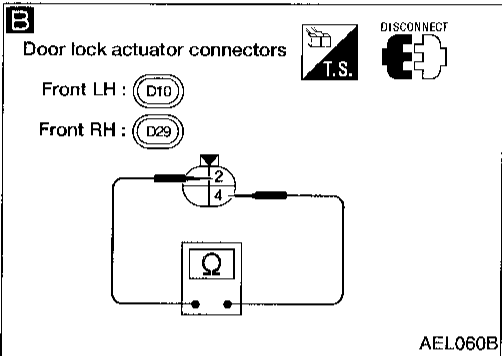
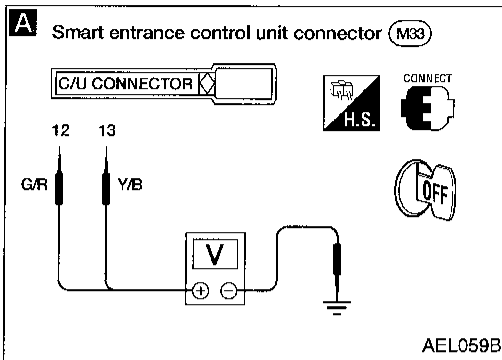

A

CHECK DOOR UNLOCK SENSOR INPUT SIGNAL.

Check voltage between control unit terminals (12), (13) and ground.

	Terminals		Condition	Voltage [V]
	⊕	⊖		
Front LH door	(12)	Ground	Locked	Approx. 12
			Unlocked	0
Front RH door	(13)	Ground	Locked	Approx. 12
			Unlocked	0

Refer to wiring diagram in EL-172 or 173.

OK

Door unlock sensor is OK.

NG

B

CHECK DOOR UNLOCK SENSOR.

1. Disconnect door unlock sensor connector.
2. Check continuity between door unlock sensor terminals.

Terminals	Condition	Continuity
(4) - (2)	Locked	No
	Unlocked	Yes

NG

Replace door unlock sensor.

OK

Check the following.

- Door unlock sensor ground circuit
- Harness for open or short between control unit and door unlock sensor

POWER DOOR LOCK

Trouble Diagnoses (Cont'd)

DIAGNOSTIC PROCEDURE 6

(Door lock actuator check)

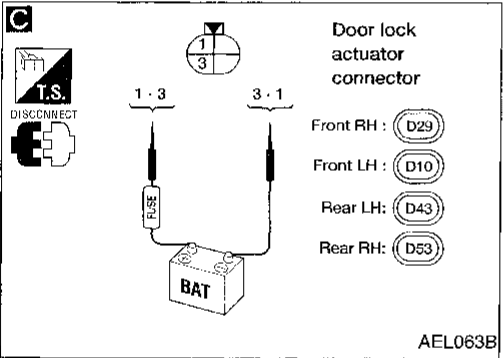
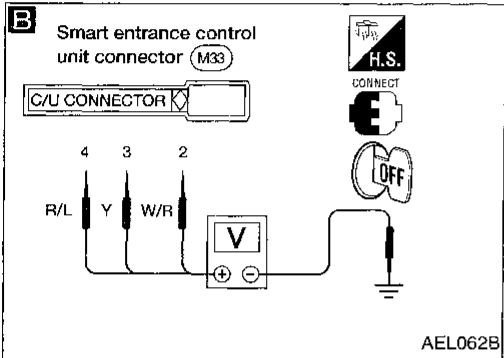
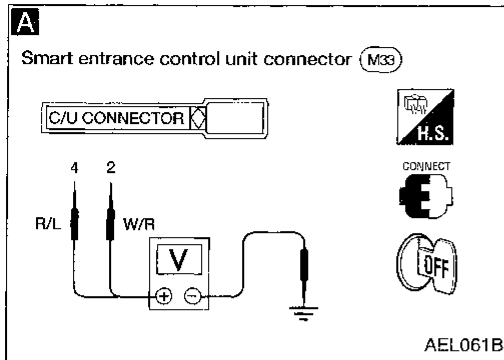

A B CHECK DOOR LOCK ACTUATOR OUTPUT.
Check voltage for door lock actuator.

A Models without multi-remote control system

Door lock/unlock switch condition	Terminals		Voltage (V)
	⊕	⊖	
Lock	④	Ground	Battery voltage
Unlock	②	Ground	

B Models with multi-remote control system

Door lock/unlock switch condition	Terminals		Voltage (V)
	⊕	⊖	
Lock	④	Ground	Battery voltage
Unlock	③ ②	Ground	

Refer to wiring diagram in EL-172 or EL-173.

NG → Replace smart entrance control unit. (Before replacing control unit, perform other procedures following SYMPTOM CHART.)

C CHECK DOOR LOCK ACTUATOR.
1. Disconnect door lock actuator connector.
2. Apply 12V direct current to door lock actuator and check operation.

Door lock actuator operation	Terminals	
	⊕	⊖
Unlocked → Locked	③	①
Locked → Unlocked	①	③

NG → Replace door lock actuator.

OK → Check harness for open or short between control unit connector and door lock actuator.

GI
MA
EM
LC
EC
FE
CL
MT
AT
FA
RA
BR
ST
RS
BT
HA
EL
IDX

MULTI-REMOTE CONTROL SYSTEM

Component Parts and Harness Connector Location

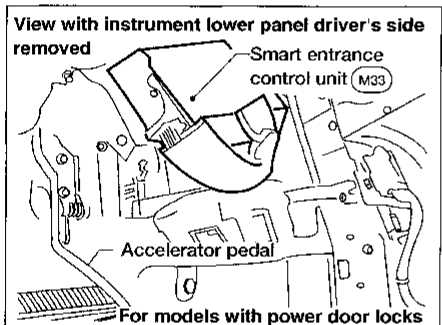
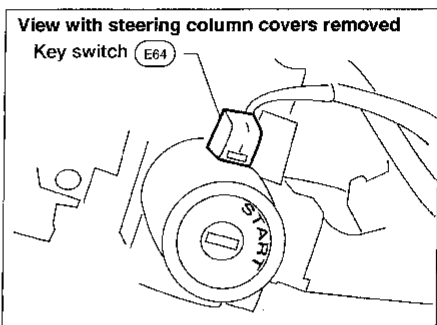
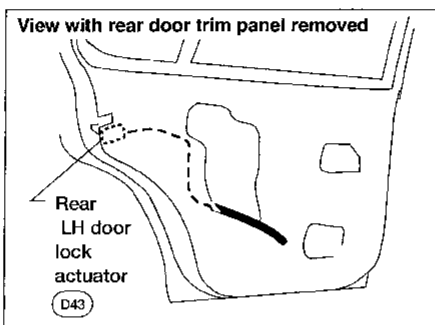
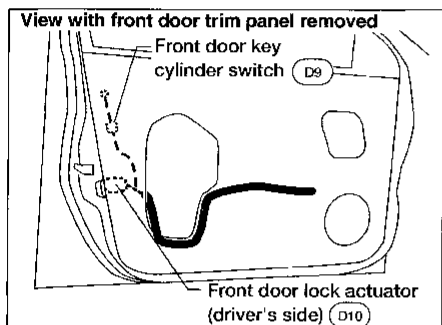
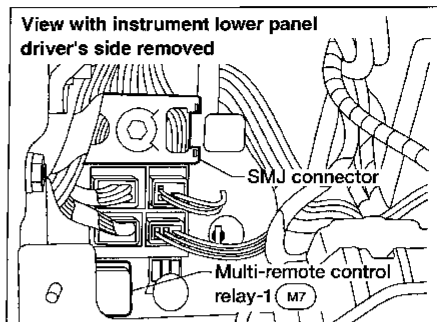
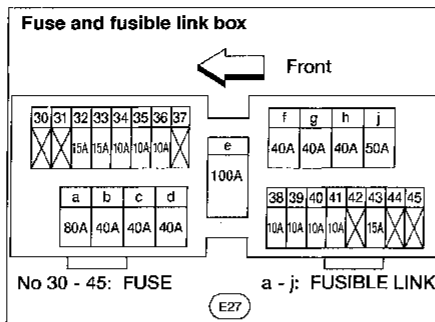
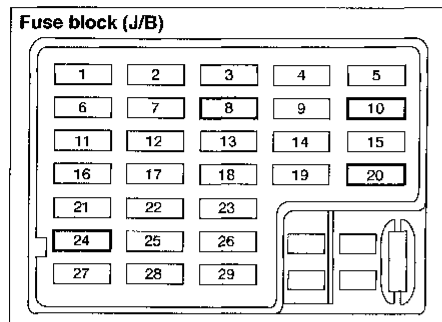

System Description

For detailed description, refer to "THEFT WARNING SYSTEM", EL-199.

Power is supplied at all times:

- through 40A fusible link (letter **d**, located in the fuse and fusible link box)
- to circuit breaker-1 terminal **①**
- through circuit breaker-1 terminal **②**
- to smart entrance control unit terminal **①**.

Power is supplied at all times:

- through 10A fuse [No. **24**, located in the fuse block (J/B)]
- to interior lamp terminal **+**
- to key switch terminal **②**.

Power is supplied at all times:

- through 10A fuse [No. **20**, located in the fuse block (J/B)]
- to multi-remote control relay-1 terminal **①**, **③** and **⑥**.

With the ignition switch in the ON or START position, power is supplied:

- through 10A fuse [No. **8**, located in the fuse block (J/B)]
- to smart entrance control unit terminal **⑪**.

With the ignition switch in the ACC or ON position, power is supplied:

- through 10A fuse [No. **10**, located in the fuse block (J/B)]
- to smart entrance control unit terminal **⑰**.

Ground is supplied:

- to smart entrance control unit terminal **⑩**
- through body grounds **M2** and **M61**.

INPUTS

When the key switch is ON (ignition key is inserted in key cylinder), power is supplied:

- through key switch terminal **①**
- to smart entrance control unit terminal **24**.

When the front door switch LH is OPEN, ground is supplied:

- to smart entrance control unit terminal **⑮**
- through front door switch LH terminal **①**
- through each door switch body ground.

When the front door switch RH is OPEN, ground is supplied:

- to smart entrance control unit terminal **35**
- through front door switch RH terminal **①**
- through each door switch body ground.

When the rear door switch is OPEN, ground is supplied:

- to smart entrance control unit terminal **⑯**
- through each rear door switch terminal **①**
- through each door switch body ground.

When the front door lock actuator LH (door unlock sensor) is UNLOCKED, ground is supplied:

- to smart entrance control unit terminal **⑫**
- through door lock actuator LH (door unlock sensor) terminal **④**
- to door lock actuator LH (door unlock sensor) terminal **②**
- through body grounds **M2** and **M61**.

When the front door lock actuator RH (door unlock sensor) is UNLOCKED, ground is supplied to smart entrance control unit terminal **⑬** in the same manner as front door lock actuator LH.

When the rear door lock actuator (door unlock sensor) is UNLOCKED, ground is supplied:

- to smart entrance control unit terminal **⑭**
- through rear door lock actuator RH or LH (door unlock sensor) terminal **④**
- to rear door lock actuator RH or LH (door unlock sensor) terminal **②**
- through body grounds **M2** and **M61** for the rear door lock actuator RH and
- through body grounds **B13** and **B19** for the rear door lock actuator LH.

Remote controller signal input:

- through internal antenna.

GI

MA

EM

LC

EC

FE

CL

MT

AT

FA

RA

BR

ST

RS

BT

HA

EL

IDX

MULTI-REMOTE CONTROL SYSTEM

System Description (Cont'd)

The multi-remote control system controls operation of the

- power door lock
- interior lamp
- panic alarm
- hazard reminder.

OPERATION PROCEDURE

Power door lock operation

When one or both of the following input signals are both supplied:

- key switch OFF (when ignition key is not inserted in key cylinder);
- door switch CLOSED (when all the doors are closed).

The above two signals are already input into the smart entrance control unit. At this point, smart entrance control unit receives a LOCK signal from the remote controller. The smart entrance control unit locks all doors with input of the LOCK signal from the remote controller.

And then ground is supplied:

- to multi-remote control relay-1 terminal ②
- through smart entrance control unit terminal ⑦.

Multi-remote control relays are now energized, and the hazard warning lamp flashes twice as a reminder—**HAZARD REMINDER**. For detailed description, refer to "Turn Signal and Hazard Warning Lamps", EL-57.

When an UNLOCK signal is sent from the remote controller once, the driver's door will be unlocked.

Then, if an UNLOCK signal is sent from the remote controller again within 5 seconds, all other doors will be unlocked.

To deactivate the horn chirp when using the remote controller, press both unlock and lock buttons for two seconds. With the horn deactivated, the exterior lights do not flash when the unlock button is pressed.

To activate the horn chirp, press both unlock and lock buttons for two seconds.

Interior lamp operation

When the following input signals are both supplied:

- key switch OFF (when ignition key is not inserted in key cylinder);
- door switch CLOSED (when all the doors are closed);

multi-remote control system turns on interior lamp (for 30 seconds) with input of UNLOCK signal from remote controller.

For detailed description, refer to "INTERIOR ROOM LAMP", EL-67.

Panic alarm operation

When key switch is OFF (when ignition key is not inserted in key cylinder), multi-remote control system turns on and off horn and headlamp intermittently with input of PANIC ALARM signal from remote controller.

For detailed description, refer to "THEFT WARNING SYSTEM", EL-199.

MULTI-REMOTE CONTROL SYSTEM

Schematic

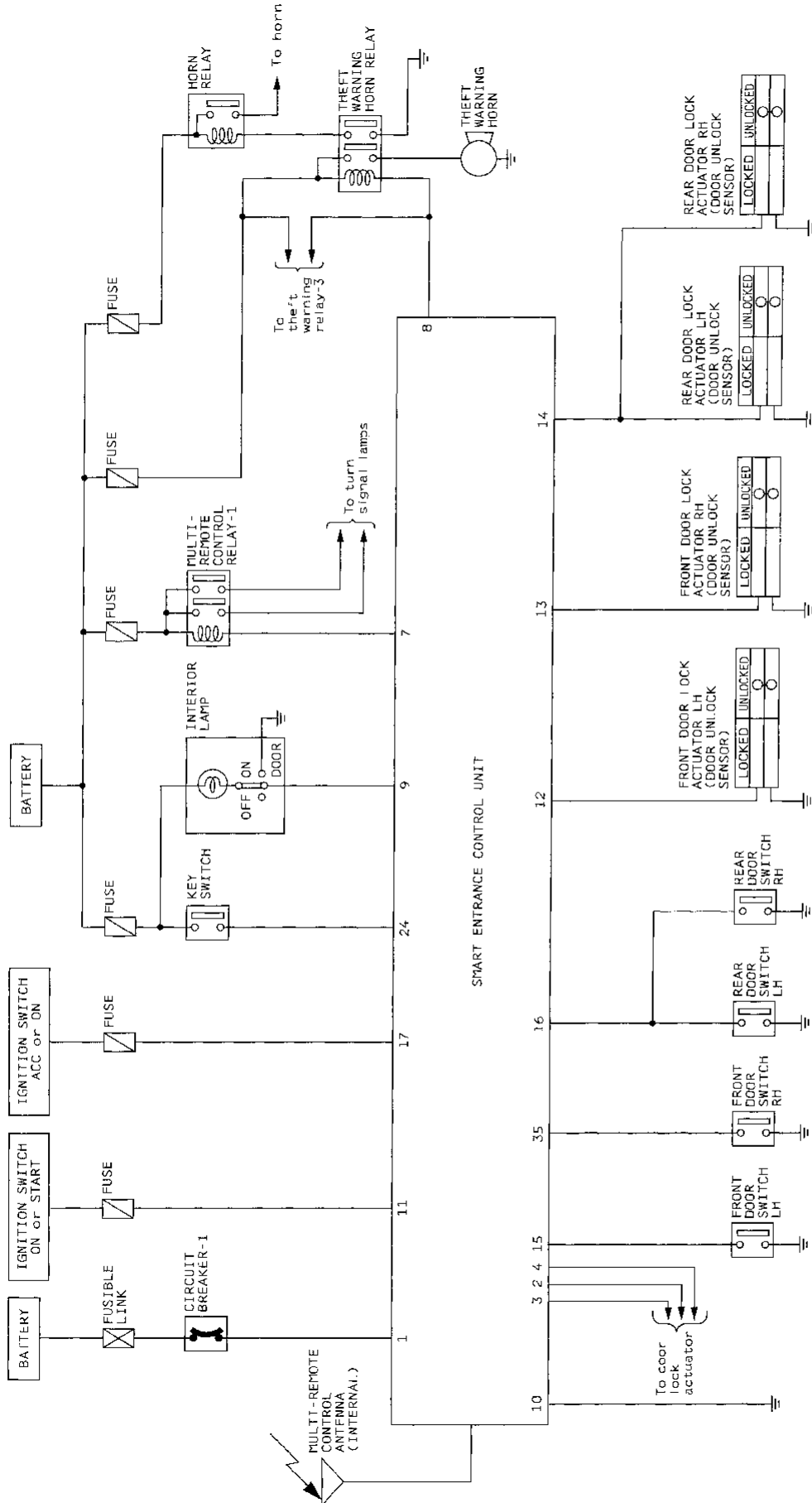

- GI
- MA
- EM
- LC
- EC
- FE
- CL
- MT
- AT
- FA
- RA
- BR
- ST
- RS
- BT
- HA
- EL**
- IDX

MULTI-REMOTE CONTROL SYSTEM

Wiring Diagram — MULTI —

EL-MULTI-01

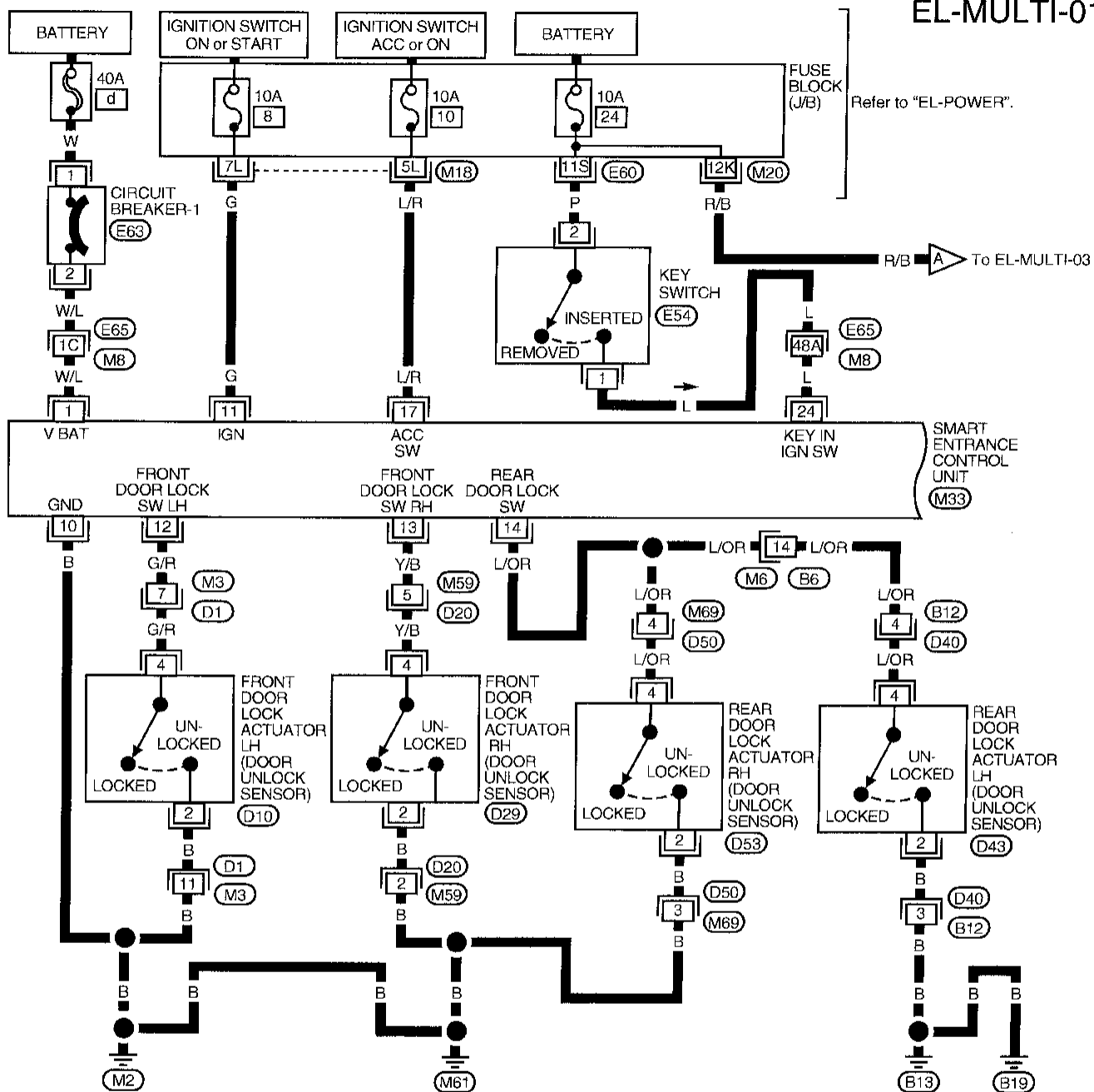

Refer to "EL-POWER".

SMART ENTRANCE CONTROL UNIT (M33)

Refer to last page (Foldout page).

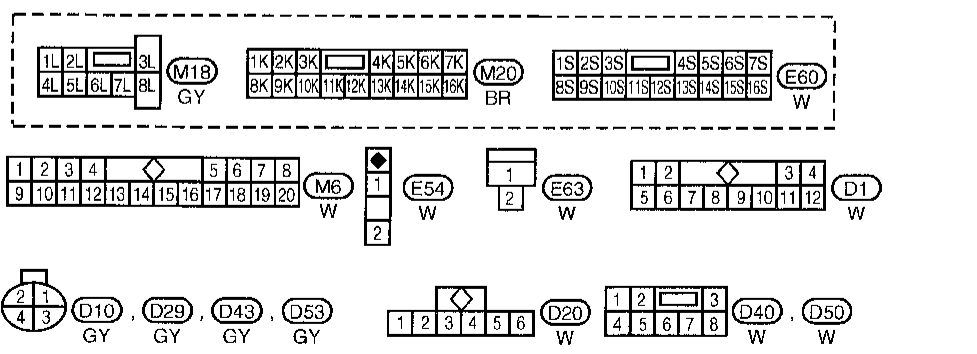

MB, E65, M33

MULTI-REMOTE CONTROL SYSTEM

Wiring Diagram — MULTI — (Cont'd)

EL-MULTI-02

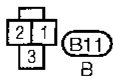
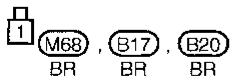
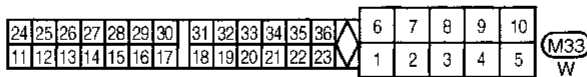
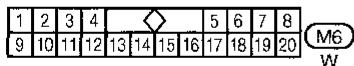
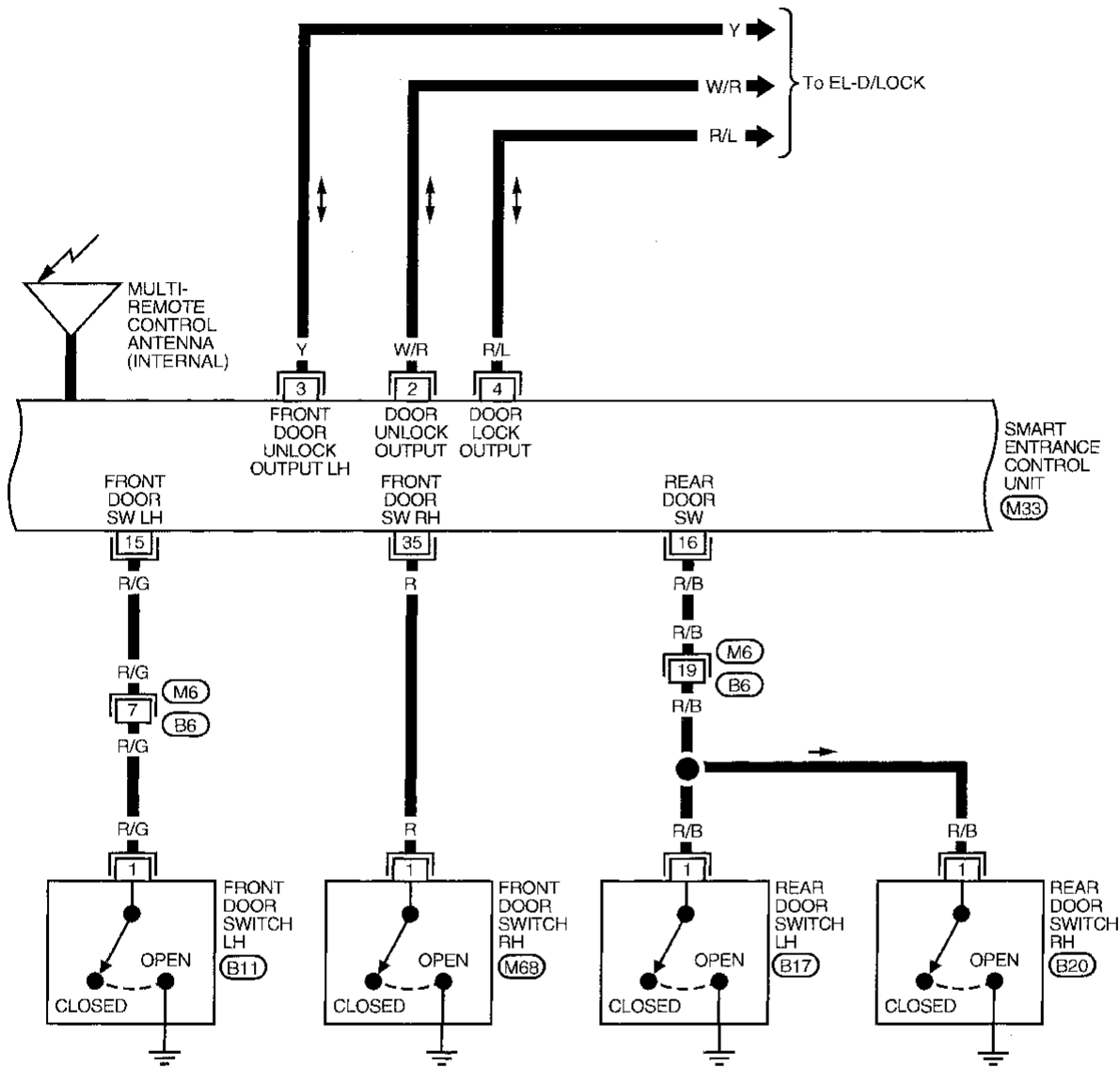

GI

MA

EM

LC

EC

FE

CL

MT

AT

FA

RA

BR

ST

RS

BT

HA

EL

IDX

MULTI-REMOTE CONTROL SYSTEM

Wiring Diagram — MULTI — (Cont'd)

EL-MULTI-03

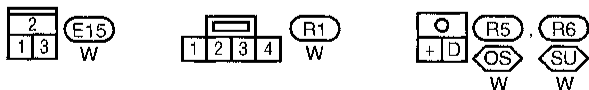
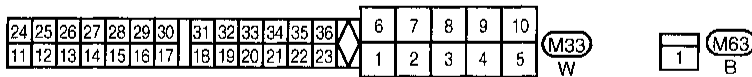
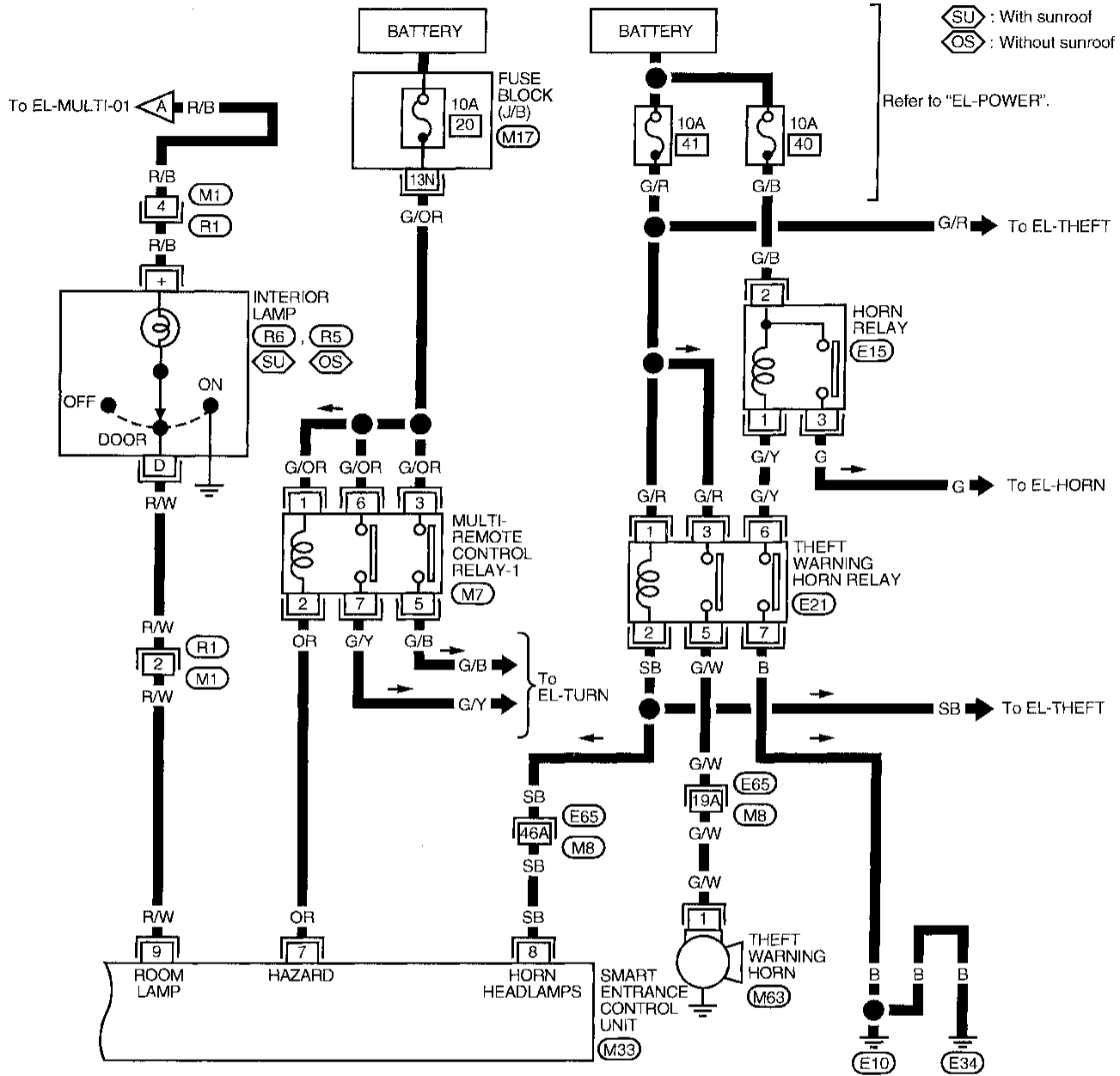

Refer to last page (Foldout page).

M8 , E65

MULTI-REMOTE CONTROL SYSTEM

Trouble Diagnoses

TROUBLE SYMPTOM

- All functions of remote control system do not operate.

GI

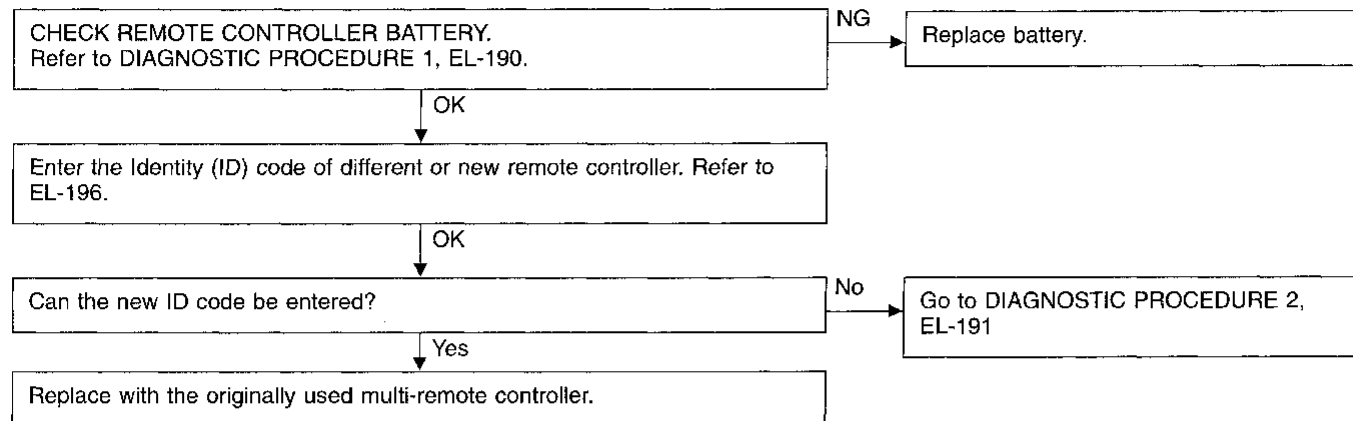

MA

EM

LC

EC

FE

- Some functions of multi-remote controller do not operate.

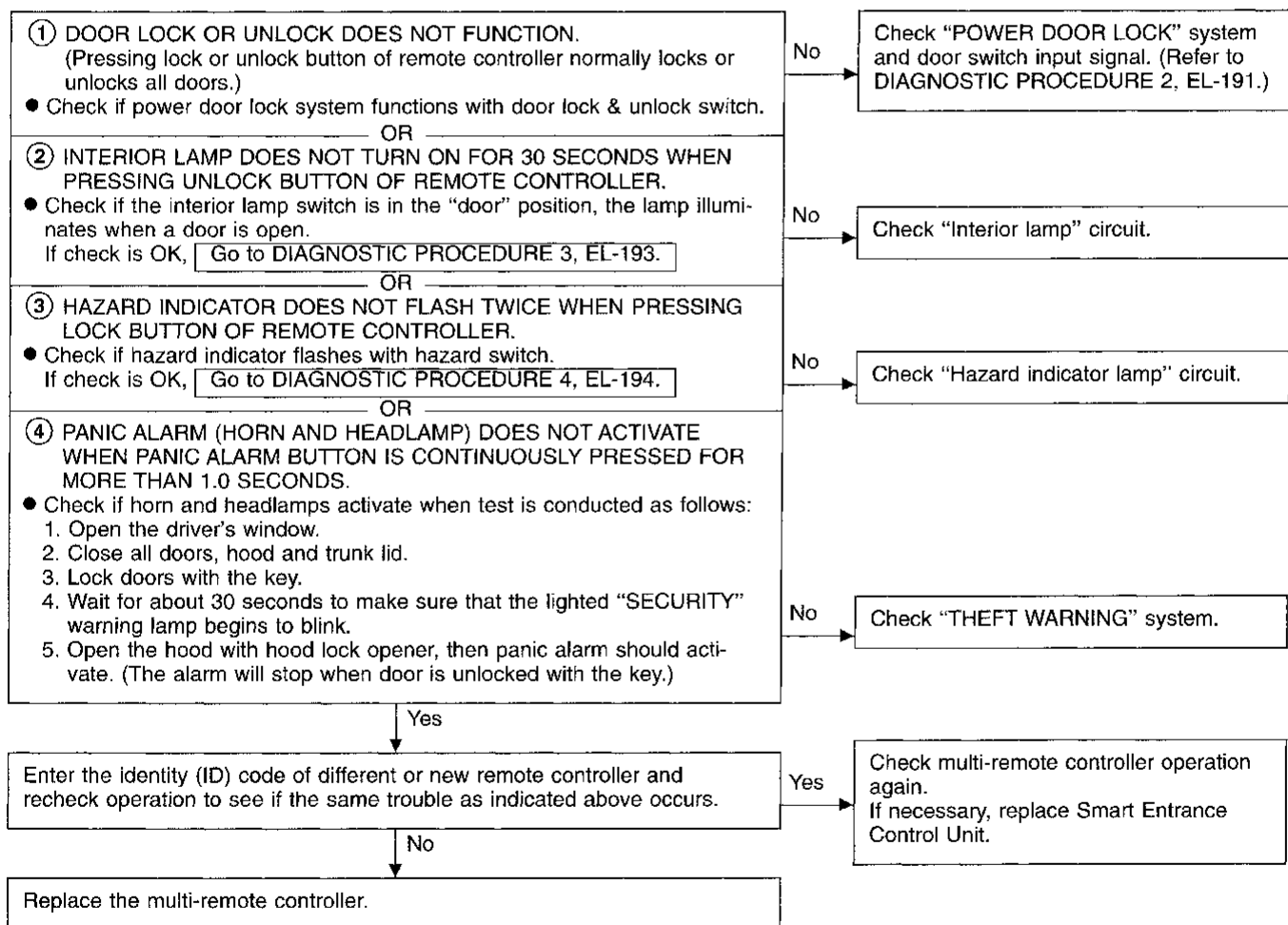

CL

MT

AT

FA

RA

BR

ST

RS

BT

HA

EL

Note: • The unlock and panic alarm operation of the multi-remote control system does not activate with the ignition key inserted in the ignition key cylinder.

IDX

- The lock operation of the multi-remote control system does not activate with the key inserted in the ignition key cylinder and one or more of the front doors are open.

MULTI-REMOTE CONTROL SYSTEM

Trouble Diagnoses (Cont'd)

DIAGNOSTIC PROCEDURE 1

Check remote controller battery.

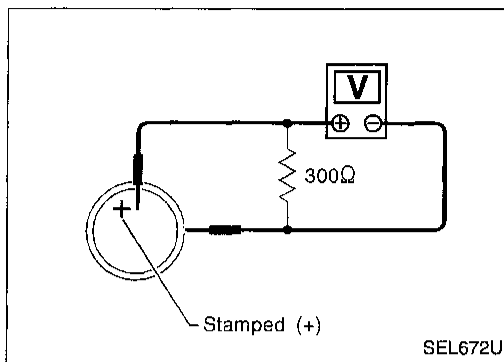

CHECK REMOTE CONTROLLER BATTERY.

Remove battery and measure voltage across battery positive and negative terminals, ⊕ and ⊖.

Measuring terminal		Standard value
⊕	⊖	
Battery positive terminal ⊕	Battery negative terminal ⊖	2.5 - 3.0V

Note:

Remote controller does not function if battery is not set correctly.

MULTI-REMOTE CONTROL SYSTEM

Trouble Diagnoses (Cont'd)

DIAGNOSTIC PROCEDURE 2

All remote controls do not function even if remote controller is operated properly.

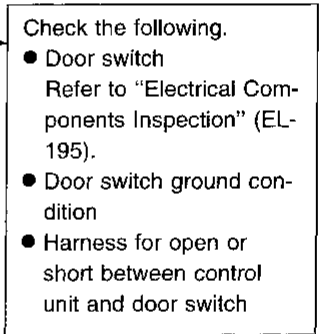
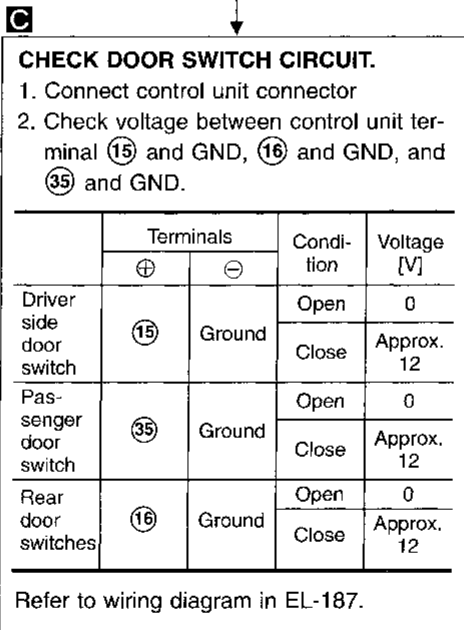
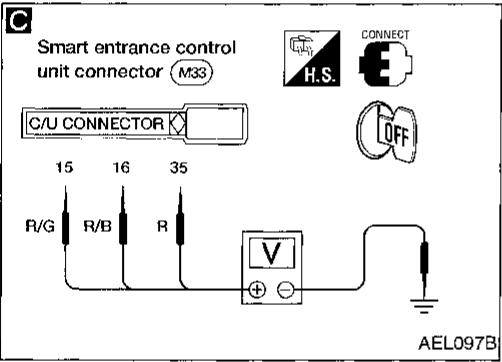
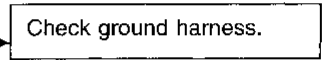
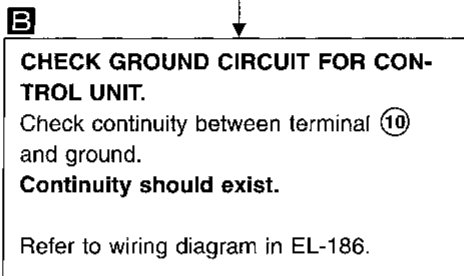
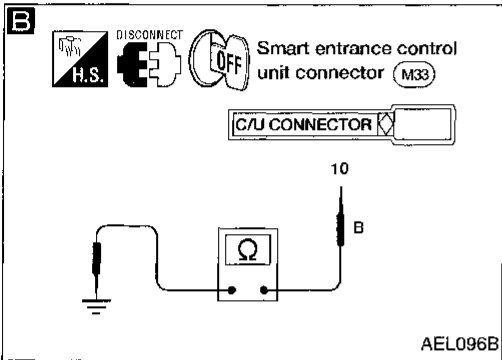
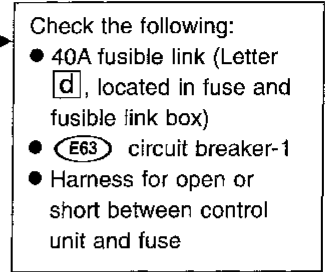
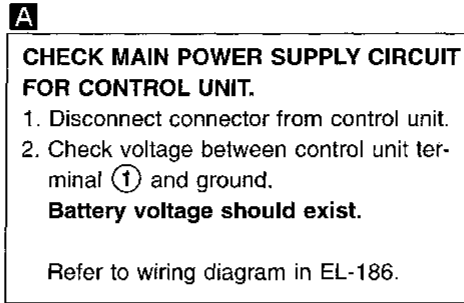
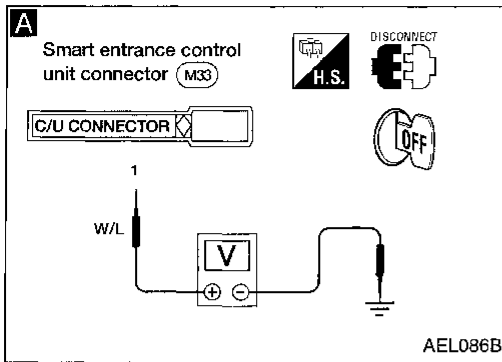

OK

Ⓐ

(Go to next page.)

GI

MA

EM

LC

EC

FE

CL

MT

AT

FA

RA

BR

ST

RS

BT

HA

EL

IDX

MULTI-REMOTE CONTROL SYSTEM

Trouble Diagnoses (Cont'd)

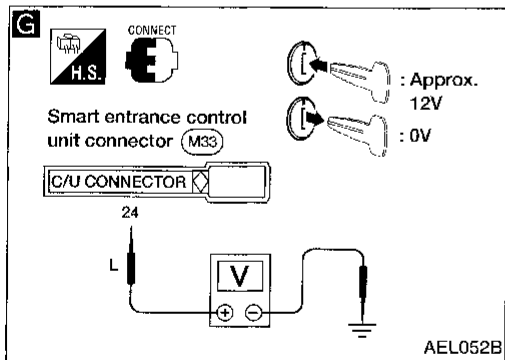
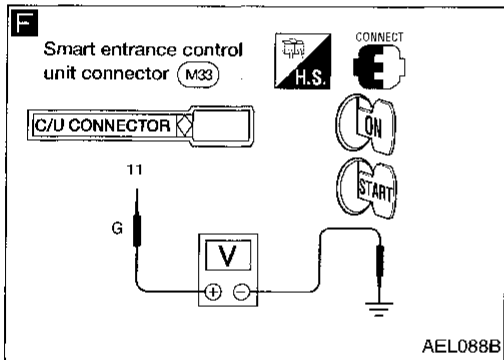
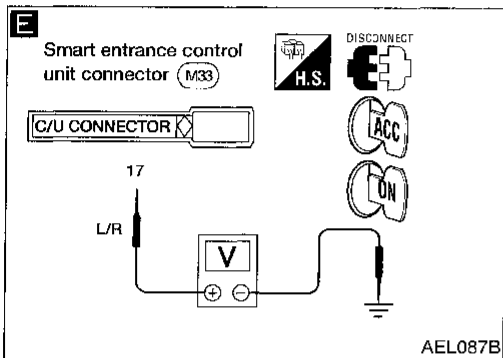
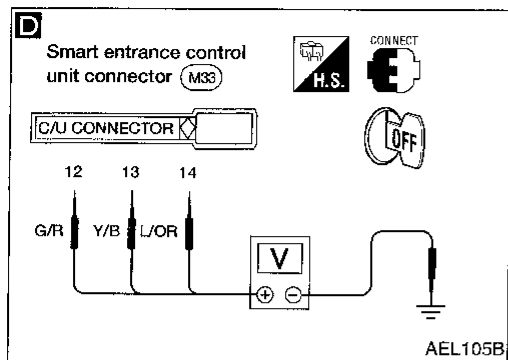

D

CHECK UNLOCK SENSOR CIRCUIT.
Check voltage between control unit terminal (12) and ground, (13) and ground, and (14) and ground.

	Terminals		Condition	Voltage [V]
	⊕	⊖		
Front LH door	(12)	Ground	Unlock	0
			Lock	Approx. 12
Front RH door	(13)	Ground	Unlock	0
			Lock	Approx. 12
Rear doors	(14)	Ground	Unlock	0
			Lock	Approx. 12

Refer to wiring diagram in EL-186.

NG → Check the following:

- Door unlock sensor
- Refer to "Electrical Components Inspection", EL-195.
- Door unlock sensor ground circuit
- Harness for open or short between control unit and unlock sensor

E

CHECK IGNITION SWITCH "ACC" OR "ON" CIRCUIT.

1. Disconnect control unit connector.
2. Check voltage between control unit terminal (17) and ground while ignition switch is in ACC or ON position. **Battery voltage should exist.**

Refer to wiring diagram in EL-186.

NG → Check the following:

- 10A fuse [No. 10], located in fuse block (J/B)
- Harness for open or short between control unit and fuse

F

CHECK IGNITION SWITCH "ON" OR "START" CIRCUIT.
Check voltage between control unit terminal (11) and ground while ignition switch is in ON or START position. **Battery voltage should exist.**

Refer to wiring diagram in EL-186

NG → Check the following:

- 10A fuse [No. 8], located in fuse block (J/B)
- Harness for open or short between control unit and fuse

G

CHECK KEY SWITCH INPUT SIGNAL.

1. Connect control unit connector.
2. Check voltage between control unit terminals (24) and ground.

Condition	Voltage [V]
Key is inserted.	Approx. 12
Key is withdrawn.	0

Refer to wiring diagram in EL-186.

NG → Check the following:

- 10A fuse [No. 24], located in fuse block (J/B)
- Key switch
- Refer to "Electrical Components Inspection", EL-195.
- Harness for open or short between key switch and fuse
- Harness for open or short between control unit and key switch

Check operation parts in multi-remote control system for function.

MULTI-REMOTE CONTROL SYSTEM

Trouble Diagnoses (Cont'd)

DIAGNOSTIC PROCEDURE 3

Interior lamp does not turn on for 30 seconds when pressing unlock button of remote controller. Everything else functions.

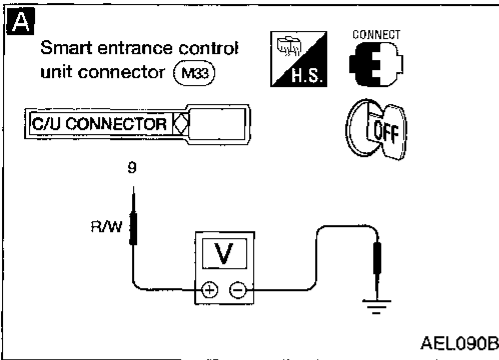

A

CHECK INTERIOR LAMP CIRCUIT.
When interior lamp switch is "DOOR" position, check voltage across control unit terminal ⑨ and ground.
Does battery voltage exist?

Refer to wiring diagram in EL-188.

No

Repair harness between control unit and interior lamp.

Yes

A

Push unlock button of remote controller and check voltage across control unit terminal ⑨ and ground.

No

Check harness for open or short between interior lamp and control unit.

Multi-remote controller button condition	Voltage (V)
Unlock button is pushed.	0
Unlock button is not pushed.	Battery voltage

Yes

Check system again.

GI

MA

EM

LC

EC

FE

CL

MT

AT

FA

RA

BR

ST

RS

BT

HA

EL

IDX

MULTI-REMOTE CONTROL SYSTEM

Trouble Diagnoses (Cont'd)

DIAGNOSTIC PROCEDURE 4

Hazard indicator does not flash twice when pressing lock button of remote controller. Everything else functions.

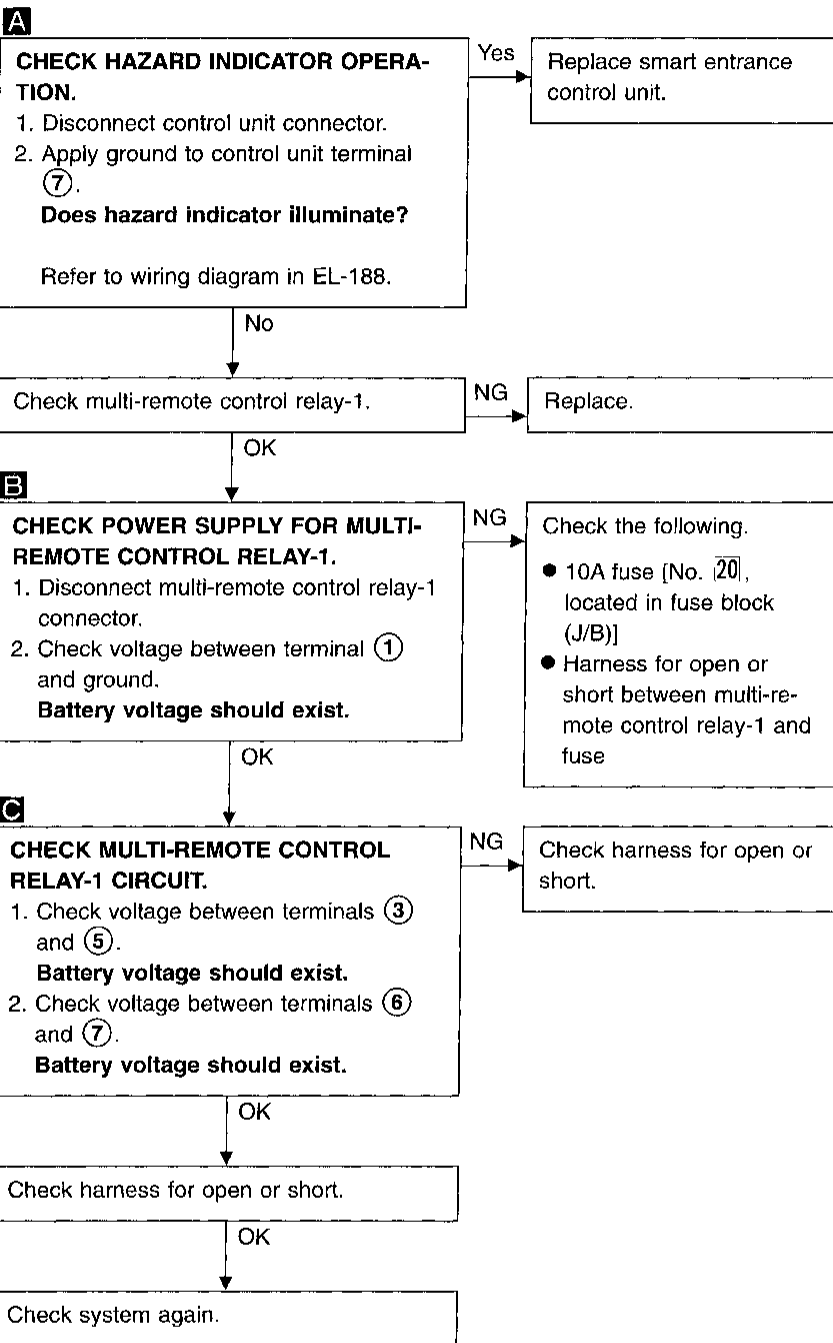
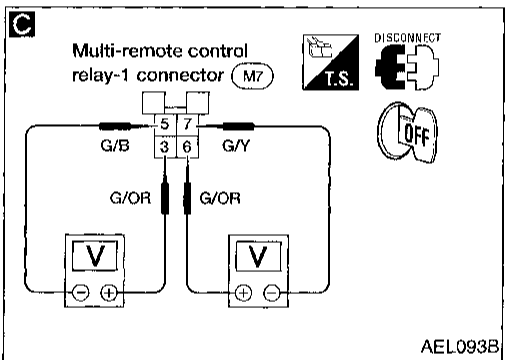
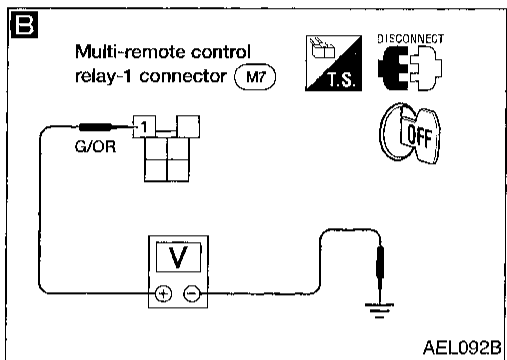
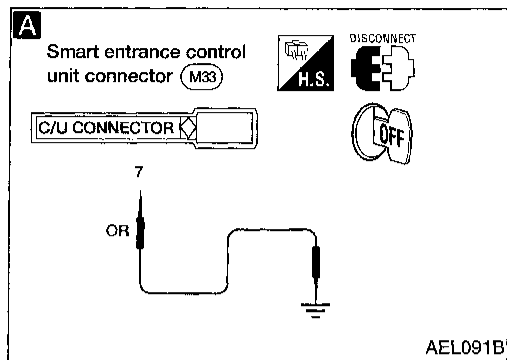

MULTI-REMOTE CONTROL SYSTEM

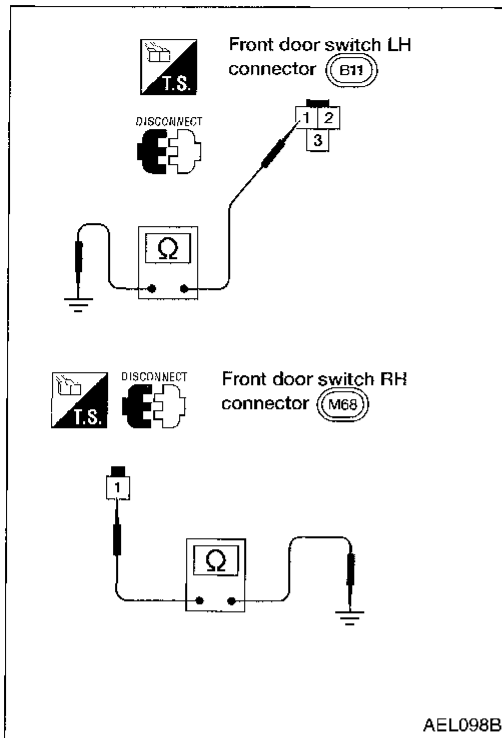

Electrical Components Inspection

DOOR SWITCHES

Check continuity between terminals when door switch is pushed and released.

	Terminal No.	Condition	Continuity
Front LH door switch	① - ground	Door switch is pushed.	No
		Door switch is released.	Yes
Other door switches	① - ground	Door switch is pushed.	No
		Door switch is released.	Yes

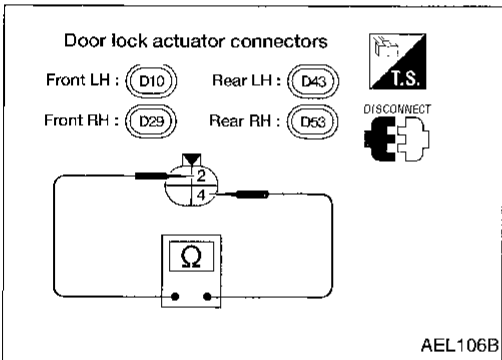

DOOR LOCK ACTUATOR (Door unlock sensor)

Check continuity between terminals when door is locked and unlocked.

Terminal No.	Condition	Continuity
④ - ②	Door is locked.	No
	Door is unlocked.	Yes

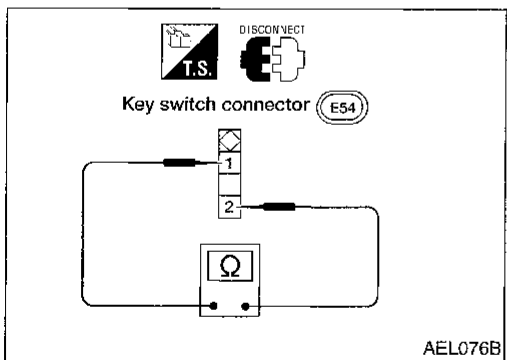

KEY SWITCH (insert)

Check continuity between terminals when key is inserted in ignition key cylinder and key is removed from ignition key cylinder.

Terminal No.	Condition	Continuity
① - ②	Key is inserted.	Yes
	Key is removed.	No

GF

MA

EM

LC

EC

FE

CL

MT

AT

FA

RA

BR

ST

RS

BT

HA

EL

IDX

MULTI-REMOTE CONTROL SYSTEM

ID Code Entry Procedure

Enter the identity (ID) code manually when:

- remote controller or control unit is replaced.
- an additional remote controller is activated.

To enter the ID code, follow the procedures below.

PROCEDURE

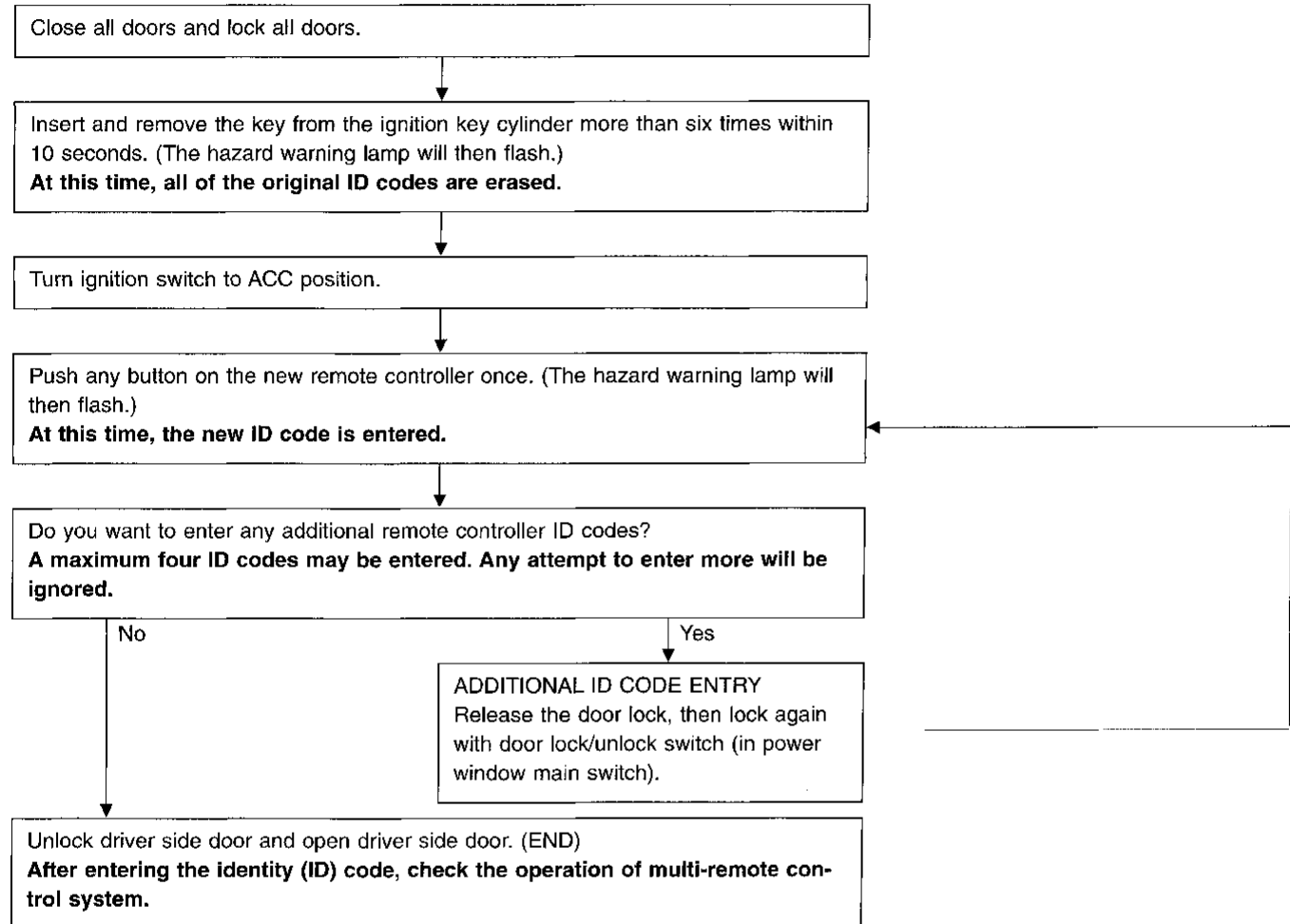

NOTE:

- If you need to activate more than two additional new remote controllers, repeat the procedure "Additional ID code entry" for each new remote controller.
- If the same ID code that exists in the memory is input, the entry will be ignored.
- Entry of four ID codes maximum is allowed and any attempt to enter more will be ignored.
- Any ID codes entered after termination of the "setting mode" will not be accepted. Additional remote control signals will be inhibited if not entered during the "setting" mode.

THEFT WARNING SYSTEM

Component Parts and Harness Connector Location

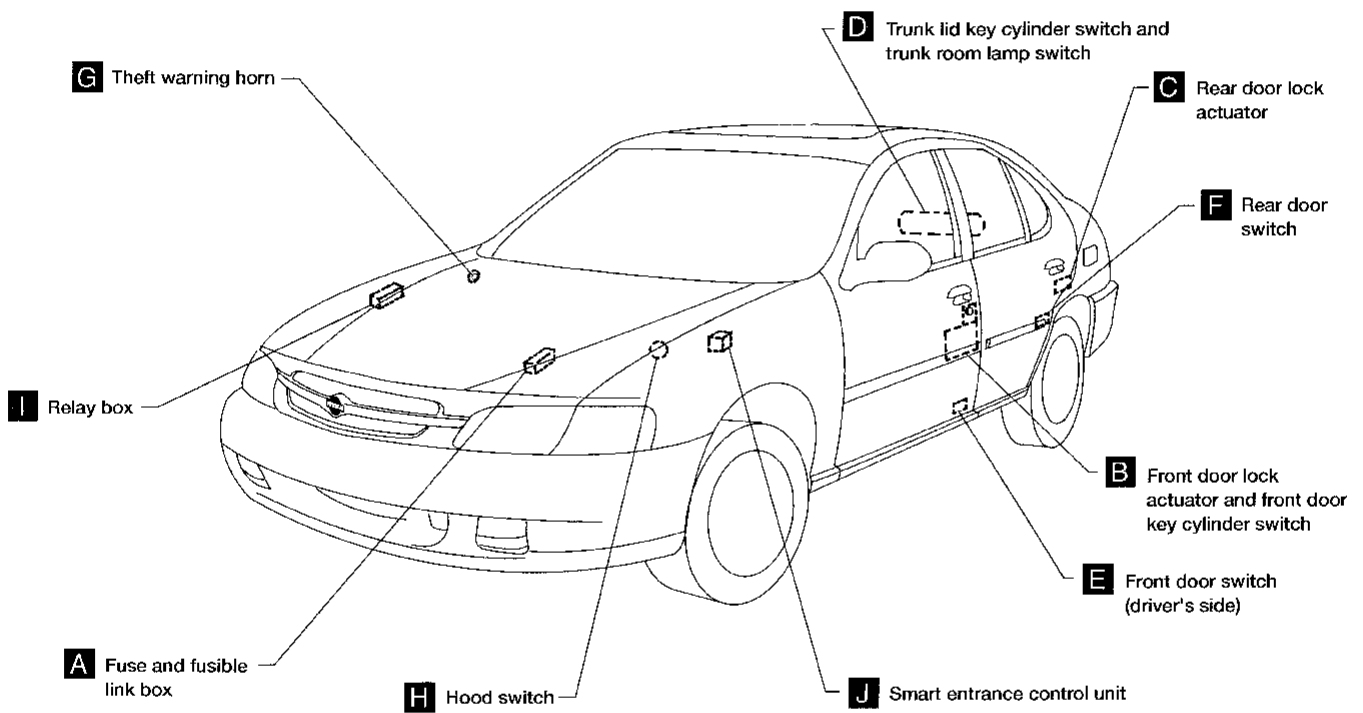

GI

MA

EM

LC

EC

FE

CL

MT

AT

FA

RA

BR

ST

RS

BT

HA

EL

IDX

THEFT WARNING SYSTEM

Component Parts and Harness Connector Location (Cont'd)

Fuse block (J/B)

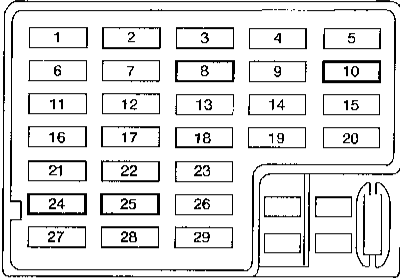

A Fuse and fusible link box

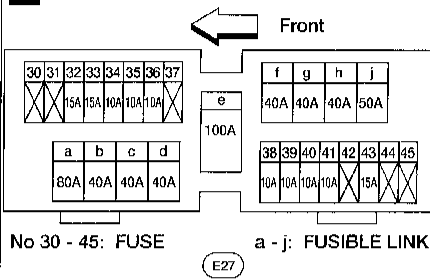

Security indicator lamp

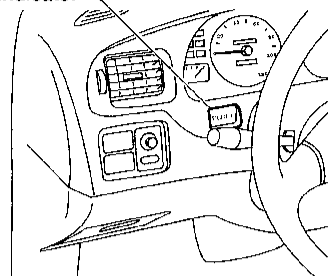

B View with front door trim panel removed

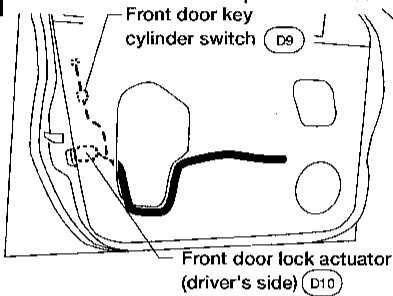

C View with rear door trim panel removed

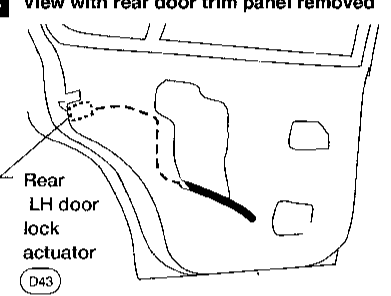

D Trunk lid

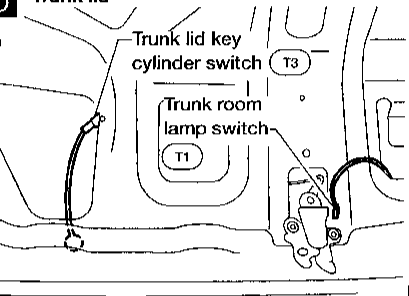

E Front door switch (driver's side) (B11)

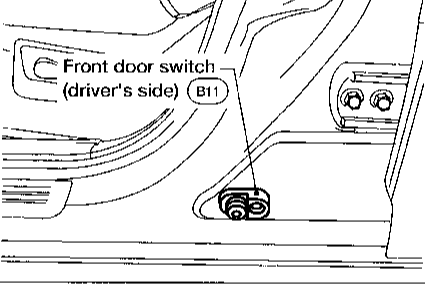

F Rear door switch LH (B17)

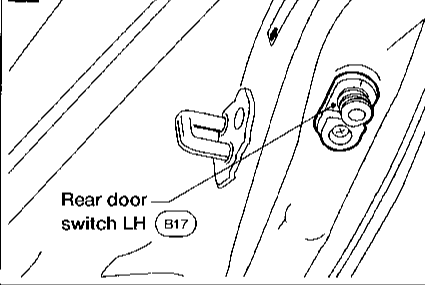

G Theft warning horn



H Hood switch (E46)

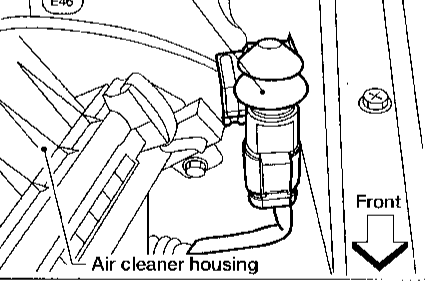

I Theft warning relay (E24)

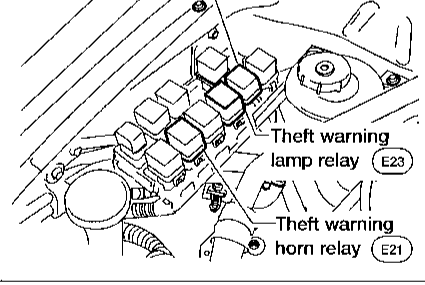

J View with instrument lower panel driver's side removed

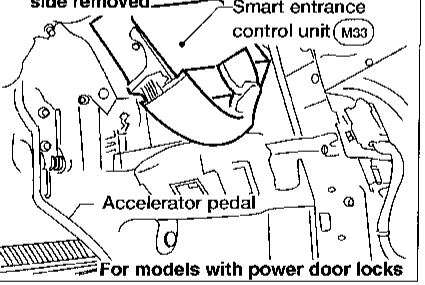

THEFT WARNING SYSTEM

System Description (Cont'd)

POWER SUPPLY AND GROUND CIRCUIT

Power is supplied at all times:

- through 10A fuse [No. 24, located in the fuse block (J/B)]
- to security indicator lamp terminal ①
- to key switch terminal ②.

When the key switch is ON (ignition key is inserted in key cylinder), power is supplied:

- through key switch terminal ①
- to smart entrance control unit terminal ②4.

Power is supplied at all times:

- through 40A fusible link (letter d, located in the fuse and fusible link box)
- to circuit breaker-1 terminal ①
- through circuit breaker-1 terminal ②
- to smart entrance control unit terminal ①.

With the ignition switch in the ACC or ON position, power is supplied:

- through 10A fuse [No. 10, located in the fuse block (J/B)]
- to smart entrance control unit terminal ①7.

With the ignition switch in the ON or START position, power is supplied:

- through 10A fuse [No. 8, located in the fuse block (J/B)]
- to smart entrance control unit terminal ①1.

Ground is supplied:

- to smart entrance control unit terminal ①0
- through body grounds M2 and M61.

INITIAL CONDITION TO ACTIVATE THE SYSTEM

The operation of the theft warning system is controlled by the doors, hood and trunk lid.

To activate the theft warning system, the smart entrance control unit must receive signals indicating the doors, hood and trunk lid are closed and the doors are locked.

When a door is open, smart entrance control unit terminals ①5, ①6 or ③5 receives a ground signal from each door switch.

When a door is unlocked, smart entrance control unit terminals ①2, ①3 or ①4 receives a ground signal:

- from terminal ④ of each door unlock sensor
- through terminal ② of each door unlock sensor
- through body grounds M2 and M61 for the front door unlock sensors LH or RH and rear door unlock sensor RH
- through body grounds B13 and B19 for the rear door unlock sensor LH.

When the hood is open, smart entrance control unit terminal ②9 receives a ground signal:

- from terminal ① of the hood switch
- through terminal ② of the hood switch
- through body grounds E34 and E10.

When the trunk lid is open, smart entrance control unit terminal ②6 receives a ground signal:

- from terminal ① of the trunk room lamp switch
- through terminal ② of the trunk room lamp switch
- through body grounds T6 and T9,

when the theft warning system is in disarmed phase,

if one of the described conditions exist, the theft warning indicator will blink every second.

THEFT WARNING SYSTEM ACTIVATION (With key or remote controller used to lock doors)

If the key is used to lock doors, smart entrance control unit terminal ③0 receives a ground signal:

- from terminal ① of the front door key cylinder switch LH
- from terminal ③ of the front door key cylinder switch RH
- through terminal ② of the front door key cylinder switch LH or RH
- through body grounds M2 and M61.

If this signal or lock signal from remote controller is received by the smart entrance control unit, the theft warning system will activate automatically.

Once the theft warning system has been activated, smart entrance control unit terminal ③3 supplies ground to terminal ② of the security indicator lamp.

THEFT WARNING SYSTEM

System Description (Cont'd)

The security lamp will illuminate for approximately 30 seconds and then blink every 2.4 seconds. Now the theft warning system is in armed phase.

THEFT WARNING SYSTEM ALARM OPERATION

The theft warning system is triggered by:

- opening a door
- opening the trunk lid
- opening the hood
- unlocking door without using the key or multi-remote controller.

Once the theft warning system is in armed phase, if the smart entrance control unit receives a ground signal at terminal ⑫, ⑬, ⑭ (door unlock sensor), ⑮, ⑯, ⑰ (door switch), ⑱ (trunk room lamp switch) or ⑲ (hood switch), the theft warning system will be triggered. The headlamps flash and the horns sound intermittently, and the starting system is interrupted.

With the IGN SW in ON or START position, power is supplied:

- through 10A fuse [No. ⑳], located in the fuse block (J/B).
- to theft warning relay terminal ①.

If the theft warning system is triggered, ground is supplied:

- from terminal ㉑ of the smart entrance control unit
- to theft warning relay terminal ②.

With power and ground supplied, power to the clutch interlock relay (M/T models) or inhibitor relay (A/T models) is interrupted. The starter motor will not crank and the engine will not start.

Power is supplied at all times:

- through 10A fuse (No. ㉒), located in fuse and fusible link box
- to theft warning lamp relay terminal ① and
- to theft warning horn relay terminal ①

When the theft warning system is triggered, ground is supplied intermittently:

- from terminal ㉓ of the smart entrance control unit
- to theft warning lamp relay terminal ② and
- to theft warning horn relay terminal ②.

The headlamps flash and the horns sound intermittently.

The alarm automatically turns off after 2 or 3 minutes but will reactivate if the vehicle is tampered with again.

GI

MA

EM

LC

EC

FE

CL

MT

AT

FA

RA

BR

ST

RS

BT

HA

EL

IDX

THEFT WARNING SYSTEM

System Description (Cont'd)

THEFT WARNING SYSTEM DEACTIVATION

To deactivate the theft warning system, a door or the trunk lid must be unlocked with the key or remote controller.

When the key is used to unlock a door, smart entrance control unit terminal ③① receives a ground signal:

- from terminal ③ of the front door key cylinder switch LH
- from terminal ① of the front door key cylinder switch RH
- through terminal ② of the front door key cylinder switch LH or RH
- through body grounds M2 and M61.

When the key is used to unlock the trunk lid, smart entrance control unit terminal ②⑦ receives a ground signal:

- from terminal ① of the trunk lid key cylinder switch
- through terminal ② of the trunk lid key cylinder switch
- through body grounds T6 and T9.

When the smart entrance control unit receives either one of these signals or unlock signal from remote controller, the theft warning system is deactivated. (Disarmed phase)

PANIC ALARM OPERATION

Multi-remote control system may or may not operate theft warning system (horn and headlamps) as required.

When the multi-remote control system is triggered, ground is supplied intermittently:

- from smart entrance control unit terminal ⑧
- to theft warning lamp relay terminal ② and
- to theft warning horn relay terminal ②.

The headlamp flashes and the horn sounds intermittently.

The alarm automatically turns off after 30 seconds or when smart entrance control unit receives any signal from multi-remote controller.

THEFT WARNING SYSTEM

Schematic

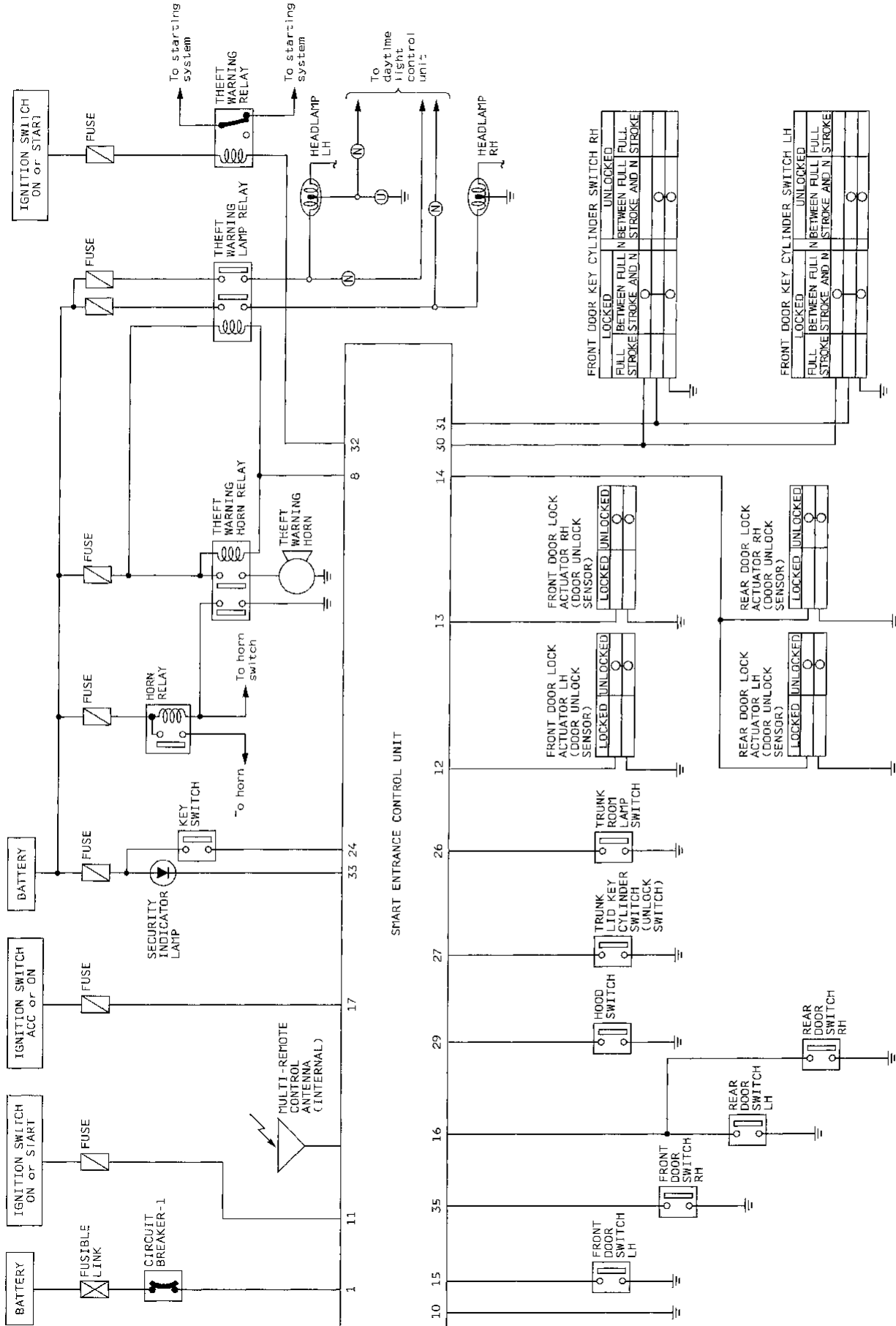

GI
MA
EM
LC
EC
FE
CL
MT
AT
FA
BA
BR
ST
RS
BT
HA
EL
IDX

Ⓢ : For USA
Ⓝ : For Canada

AEL991A

THEFT WARNING SYSTEM

Wiring Diagram — THEFT —

EL-THEFT-01

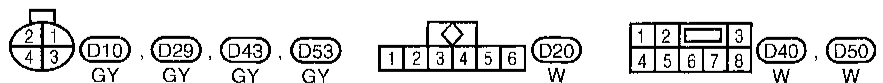
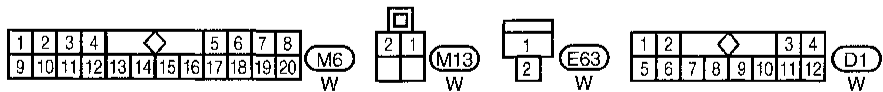
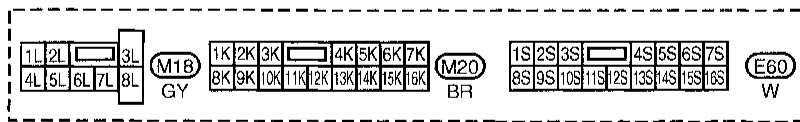
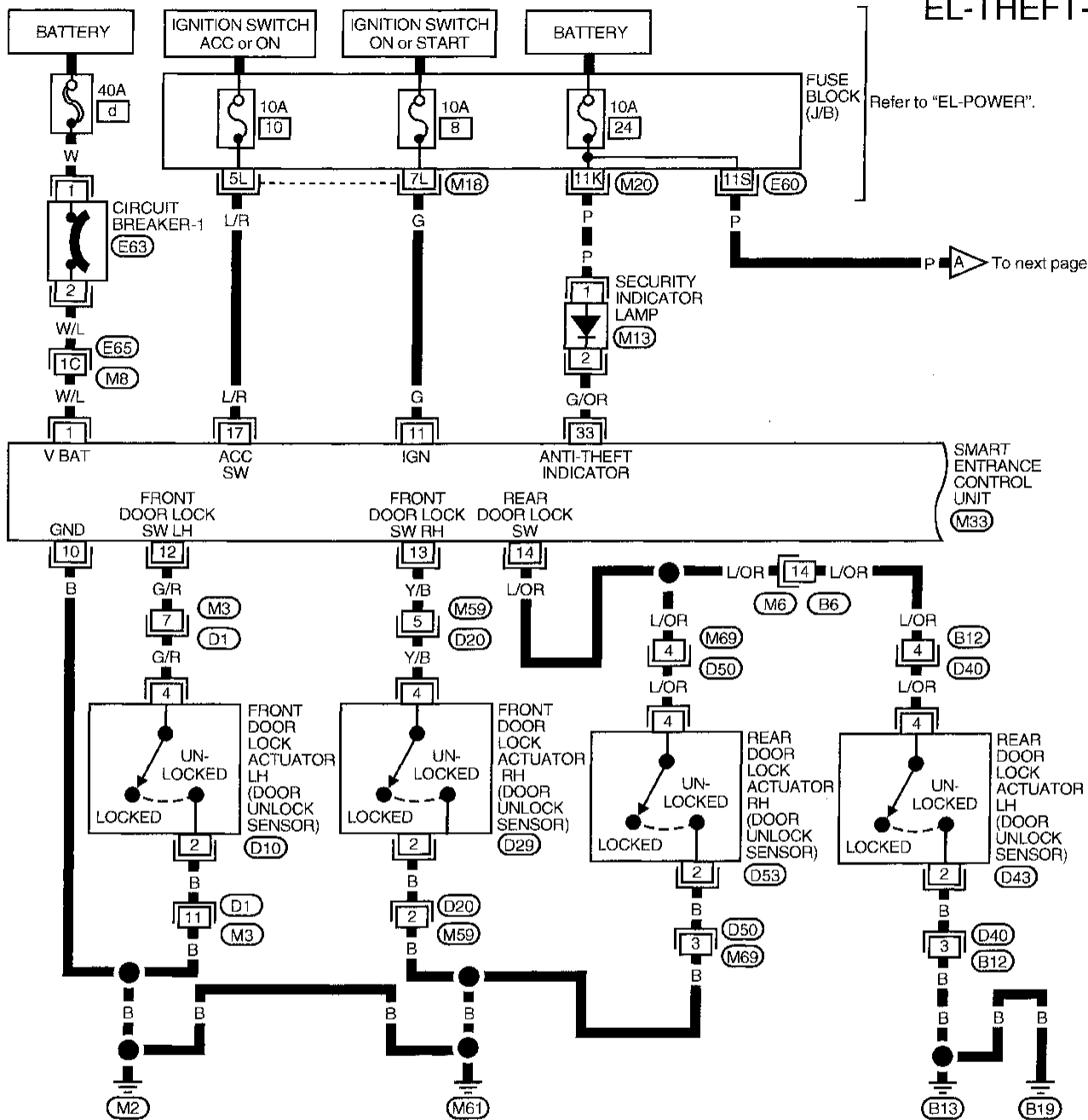

Refer to last page (Foldout page).

M8, E65
M33

THEFT WARNING SYSTEM

Wiring Diagram — THEFT — (Cont'd)

EL-THEFT-02

GI

MA

EM

LC

EC

FE

CL

MT

AT

FA

RA

BR

ST

RS

BT

HA

EL

IDX

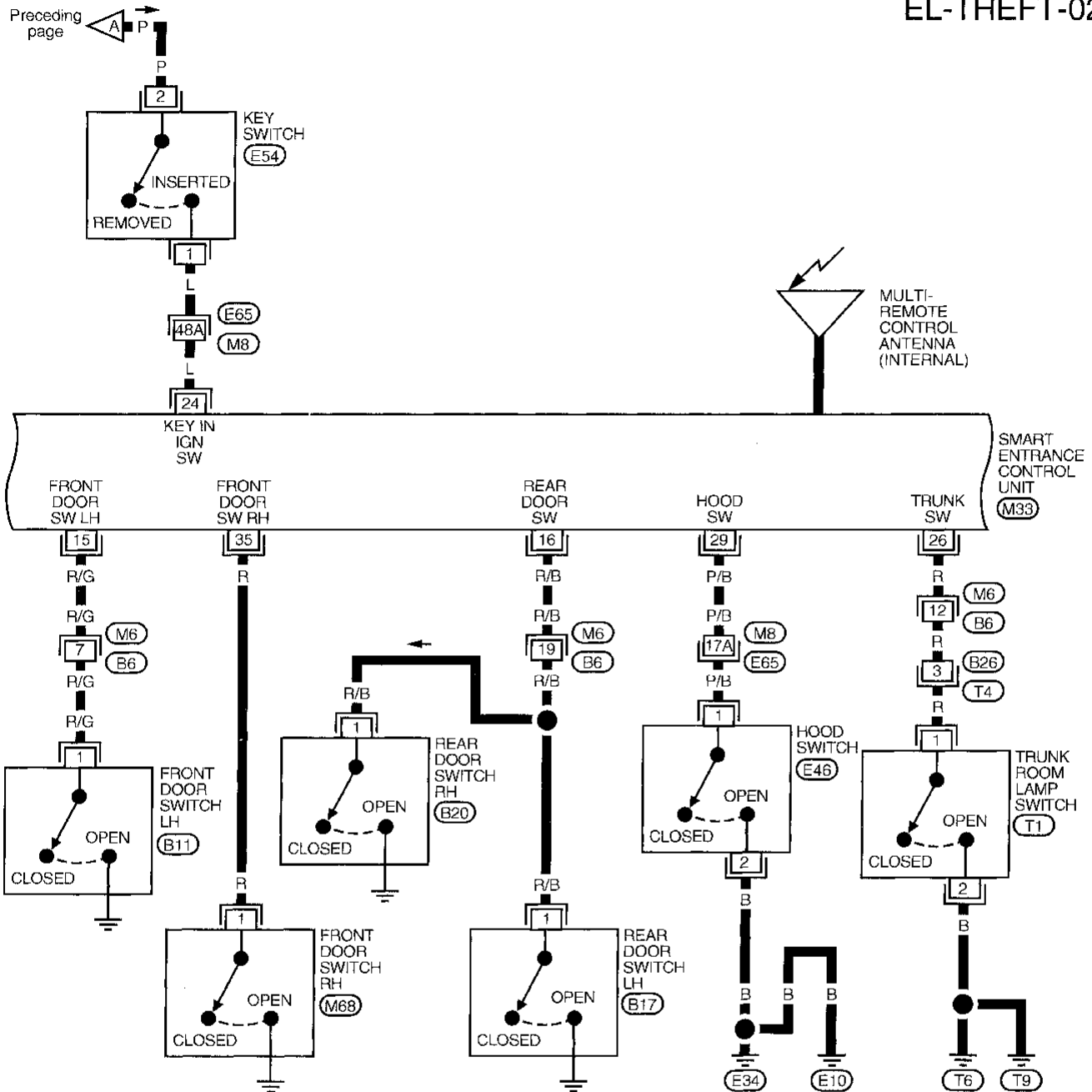

Refer to last page (Foldout page).

(M8), (E65)

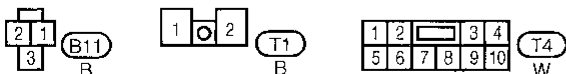
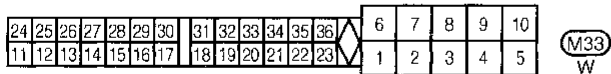

THEFT WARNING SYSTEM

Wiring Diagram — THEFT — (Cont'd)

EL-THEFT-03

M : M/T model
A : A/T model

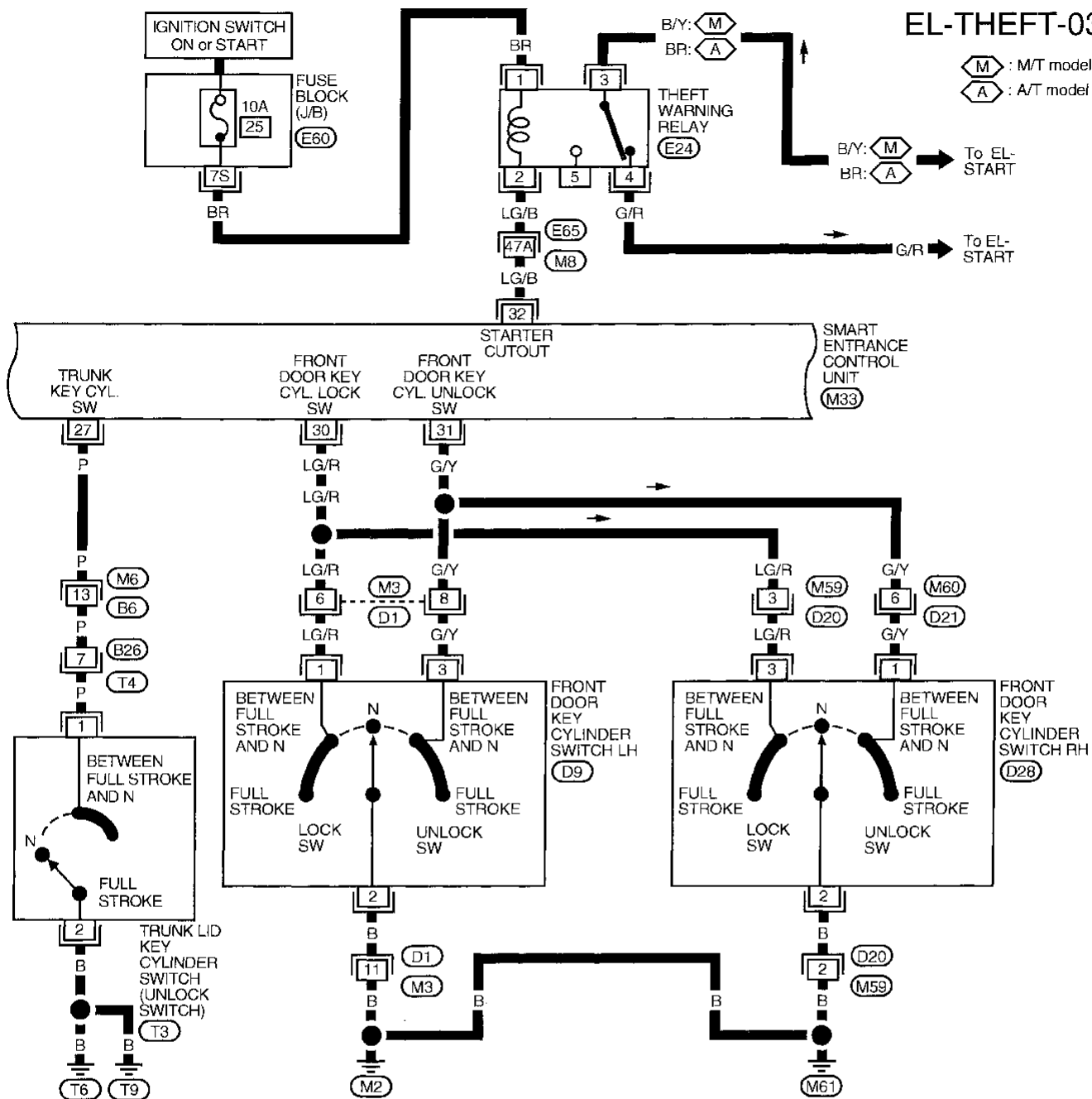

Refer to last page (Foldout page).

M8, E65

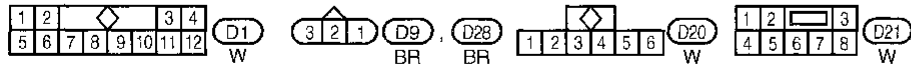
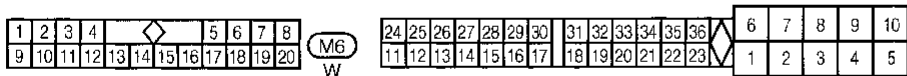

THEFT WARNING SYSTEM

Wiring Diagram — THEFT — (Cont'd)

EL-THEFT-04

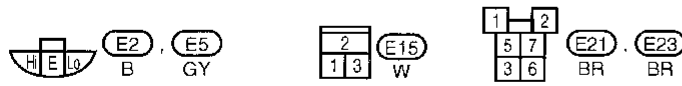
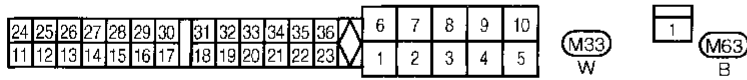
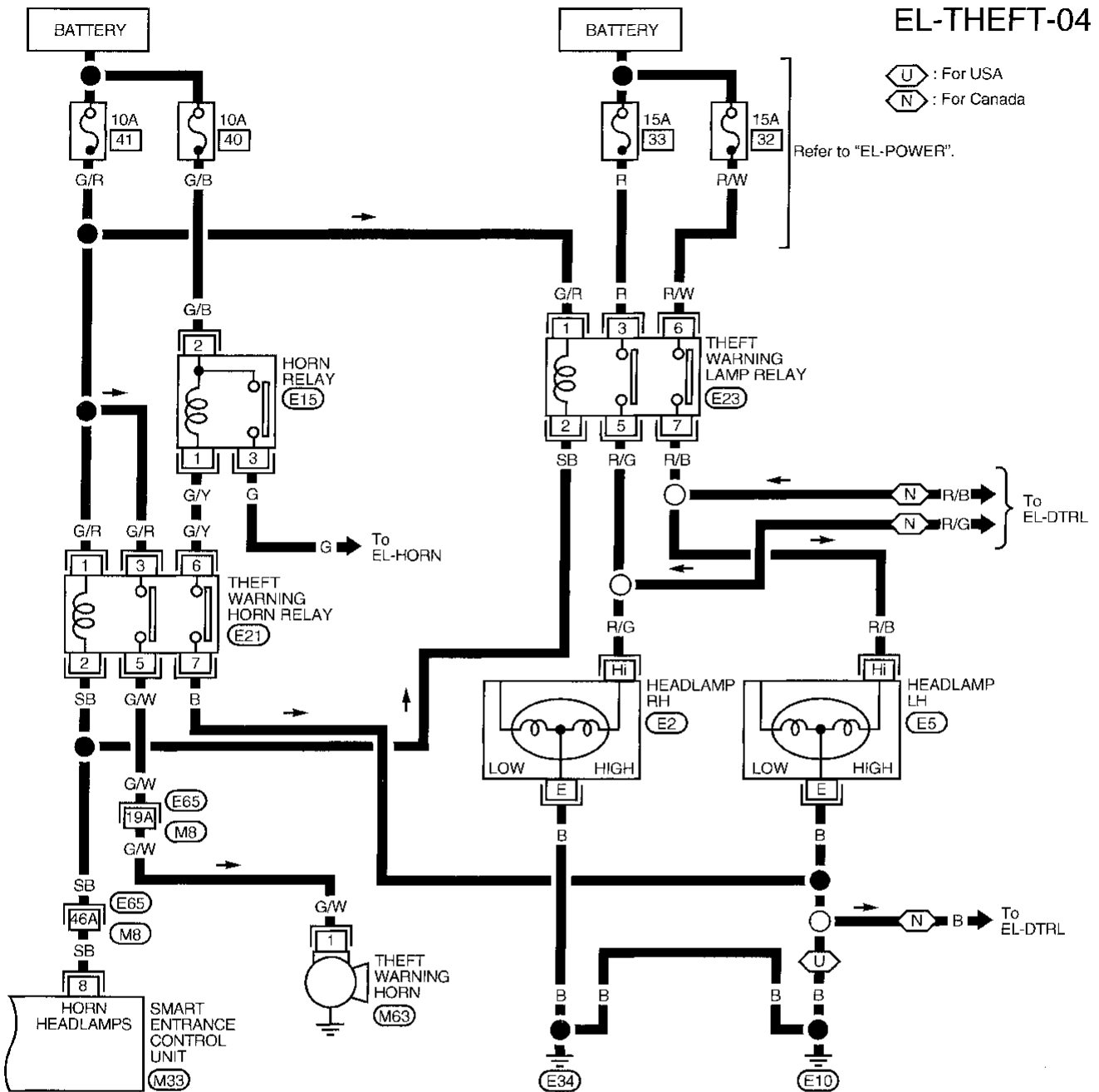

Refer to last page (Foldout page).
M8, E65

GI
MA
EM
LC
EC
FE
CL
MT
AT
FA
RA
BR
ST
RS
BT
HA
EL
IDX

THEFT WARNING SYSTEM

Trouble Diagnoses

PRELIMINARY CHECK

The system operation is canceled by turning ignition switch to ACC at any step between START and ARMED in the following flow chart.

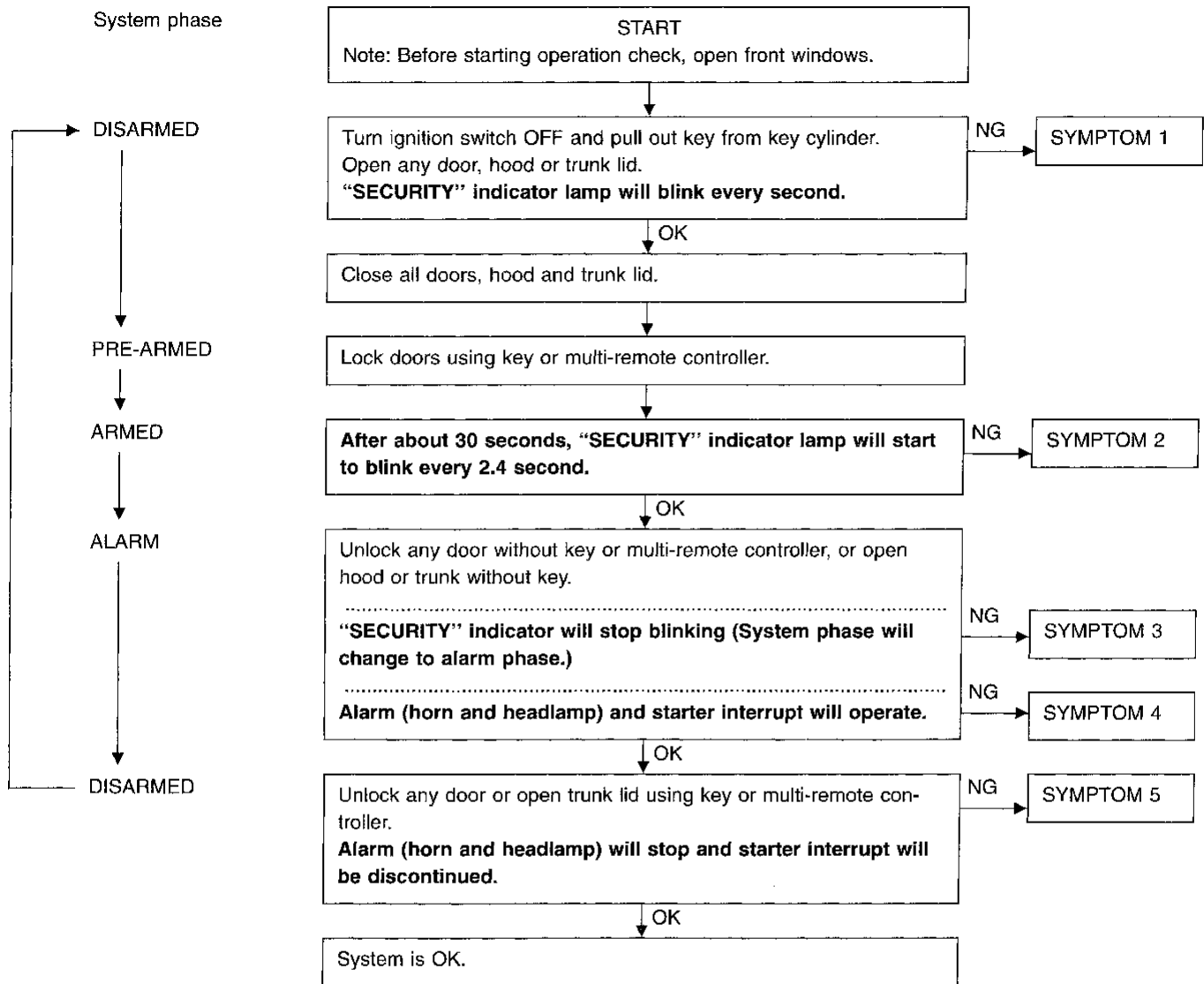

After performing preliminary check, go to symptom chart on next page.

THEFT WARNING SYSTEM

Trouble Diagnoses (Cont'd)

Before starting trouble diagnoses below, perform preliminary check, EL-208.

Symptom numbers in the symptom chart correspond with those of preliminary check.

SYMPTOM CHART

PROCEDURE		—	Power supply and ground circuit check		Diagnostic procedure								—	
			EL-208	EL-210	EL-210	EL-176	EL-214	EL-180	EL-179	EL-217	EL-218	EL-219		EL-220
REFERENCE PAGE														
SYMPTOM		Preliminary check	Power supply circuit check	Ground circuit check	Diagnostic Procedure 1 (Door, hood and trunk room lamp switch check)	Diagnostic Procedure 2 (Security Indicator lamp check)	Diagnostic Procedure 3 (Door unlock sensor check)	Diagnostic Procedure 4 (Door key cylinder switch check)	Diagnostic Procedure 5 (Trunk lid key cylinder switch check)	Diagnostic Procedure 6 (Theft warning horn alarm check)	Diagnostic Procedure 7 (Headlamp alarm check)	Diagnostic Procedure 8 (Starter interrupt system check)	Check "MULTI-REMOTE CONTROL" system.	
1	Theft warning indicator does not turn "ON" or blinking.	X	X	X		X								
2	Theft warning system cannot be set by ...	All items	X	X	X	X		X						
		Door out side key	X	X	X				X					
		Multi-remote control	X	X	X								X	
3	*1 Theft warning system does not alarm when ...	Any door is opened.	X	X	X	X								
		Any door is unlocked without using key or multi-remote controller	X	X	X			X						
4	Theft warning system does not activate.	All function	X	X	X	X		X						
		Horn alarm	X	X	X					X				
		Headlamp alarm	X	X	X							X		
		Starter interrupt	X	X	X								X	
5	Theft warning system cannot be canceled by ...	Door out side key	X	X	X			X						
		Trunk lid key	X	X	X				X					
		Multi-remote control	X	X	X								X	

X : Applicable

*1: Make sure the system is in the armed phase.

GI

MA

EM

LC

EC

FE

CL

MT

AT

FA

RA

BR

ST

RS

BT

HA

EL

IDX

THEFT WARNING SYSTEM

Trouble Diagnoses (Cont'd)

POWER SUPPLY AND GROUND CIRCUIT CHECK

Power supply circuit check

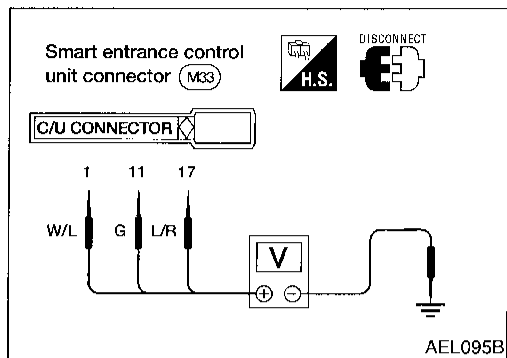

Terminals		Ignition switch position		
⊕	⊖	OFF	ACC	ON
①	Ground	Battery voltage	Battery voltage	Battery voltage
⑪	Ground	0V	0V	Battery voltage
⑰	Ground	0V	Battery voltage	Battery voltage

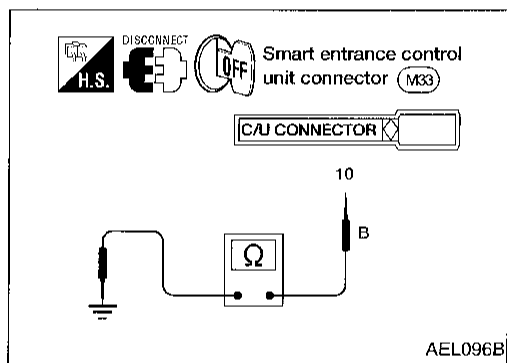

Ground circuit check

Terminals	Continuity
⑩ - Ground	Yes

THEFT WARNING SYSTEM

Trouble Diagnoses (Cont'd)

DIAGNOSTIC PROCEDURE 1-(1) (Door switch check)

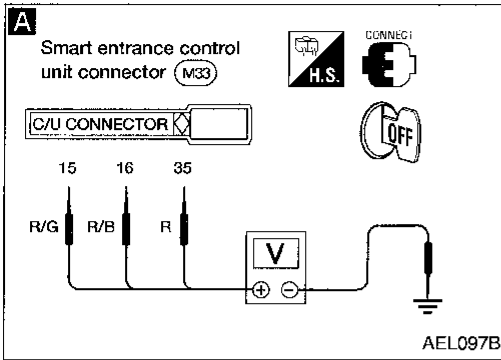

1. Turn ignition switch OFF and remove key from key cylinder.
2. Close all doors, hood and trunk lid. **"SECURITY" indicator lamp should turn off.**
3. Open any passenger door. **"SECURITY" indicator lamp should blink every second.**

OK → Door switch is OK.

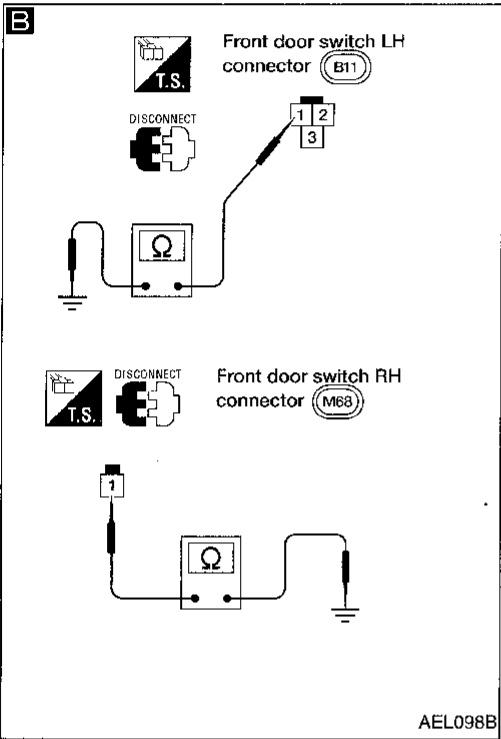

- A**
- CHECK DOOR SWITCH INPUT SIGNAL.**
Check voltage between control unit terminals (15), (16) or (35) and ground.

	Terminals		Condition	Voltage [V]
	⊕	⊖		
Front LH door switch	(15)	Ground	Open	0
			Closed	Approx. 12
Front RH door switch	(35)	Ground	Open	0
			Closed	Approx. 12
Rear door switches	(16)	Ground	Open	0
			Closed	Approx. 12

Refer to wiring diagram in EL-204.

OK → Door switch is OK.

- B**
- CHECK DOOR SWITCH.**
1. Disconnect door switch connector.
2. Check continuity between door switch terminals.

	Terminals	Condition	Continuity
Front LH door switch	① - Ground	Closed	No
		Open	Yes
Other door switches	① - Ground	Closed	No
		Open	Yes

NG → Replace door switch.

- OK
- Check the following.
- Door switch ground circuit (Front LH) or door switch ground condition
 - Harness for open or short between control unit and door switch

GI

MA

EM

LC

EC

FE

CL

MT

AT

FA

RA

BR

ST

RS

BT

HA

EL

IDX

THEFT WARNING SYSTEM

Trouble Diagnoses (Cont'd)

DIAGNOSTIC PROCEDURE 1-(2) (Hood switch check)

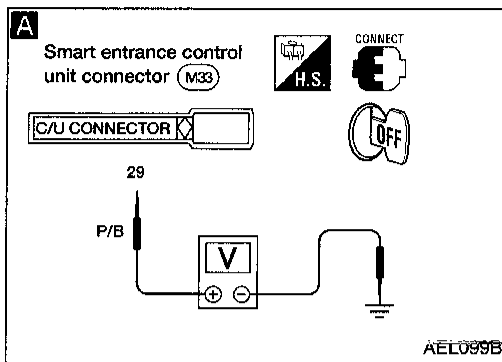

1. Turn ignition switch OFF and remove key from key cylinder.
2. Close all doors, hood and trunk lid. **"SECURITY" indicator lamp should turn off.**
3. Open hood. **"SECURITY" indicator lamp should blink every second.**

OK → Hood switch is OK.

NG

Check hood switch and hood fitting condition.

NG → Adjust installation of hood switch or hood.

OK

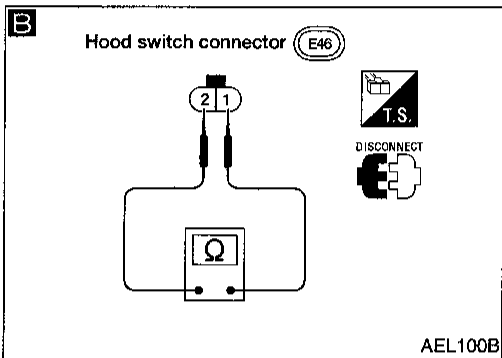

A

CHECK HOOD SWITCH INPUT SIGNAL.
Check voltage between control unit terminal (29) and ground.

OK → Hood switch is OK.

Condition	Voltage [V]
Hood is open.	0
Hood is closed.	Approx. 12

Refer to wiring diagram in EL-205.

NG

B

CHECK HOOD SWITCH.
1. Disconnect hood switch connector.
2. Check continuity between hood switch terminals.

NG → Replace hood switch.

Terminals	Condition	Continuity
① - ②	Pushed	No
	Released	Yes

OK

Check the following.

- Hood switch ground circuit
- Harness for open or short between control unit and hood switch

THEFT WARNING SYSTEM

Trouble Diagnoses (Cont'd)

DIAGNOSTIC PROCEDURE 1-(3) (Trunk room lamp switch check)

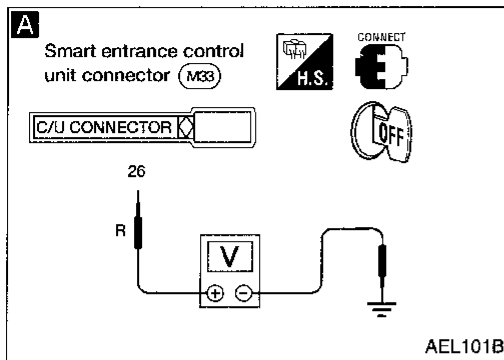

1. Turn ignition switch OFF and remove key from key cylinder.
2. Close all doors, hood and trunk lid. **"SECURITY" indicator lamp should turn off.**
3. Open trunk lid. **"SECURITY" indicator lamp should blink every second.**

OK → Trunk room lamp switch is OK.

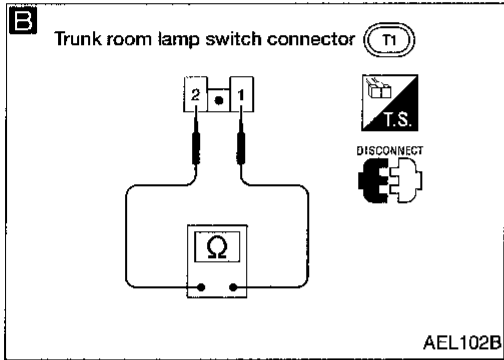

A

CHECK TRUNK ROOM LAMP SWITCH INPUT SIGNAL.
Check voltage between control unit terminal (26) and ground.

Condition	Voltage [V]
Trunk lid is open.	Approx. 0
Trunk lid is closed.	Approx. 12

Refer to wiring diagram in EL-205.

OK → Trunk room lamp switch is OK.

B

CHECK TRUNK ROOM LAMP SWITCH.

1. Disconnect trunk room lamp switch connector.
2. Check continuity between trunk room lamp switch terminals.

Terminals	Condition	Continuity
① - ②	Closed	No
	Open	Yes

NG → Replace trunk room lamp switch.

- OK →
- Check the following.
- Trunk room lamp switch ground circuit
 - Harness for open or short between control unit and trunk room lamp switch

GI
MA
EM
LC
EC
FE
CL
MT
AT
FA
RA
BR
ST
RS
BT
HA
EL
IDX

THEFT WARNING SYSTEM

Trouble Diagnoses (Cont'd)

DIAGNOSTIC PROCEDURE 2 (Security indicator lamp check)

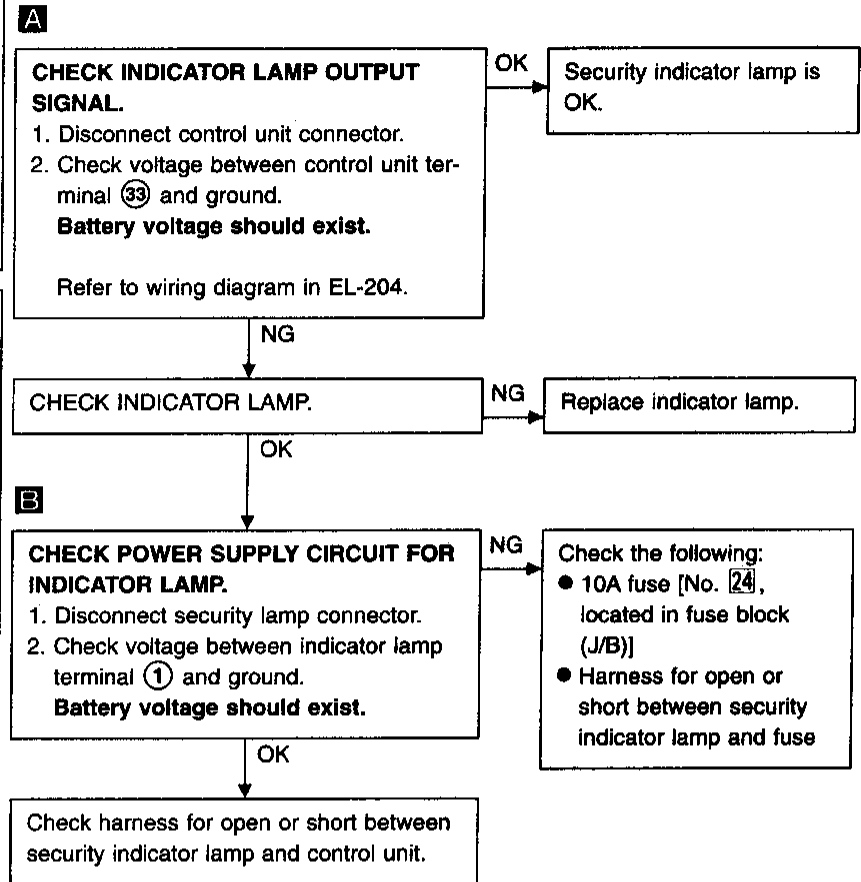
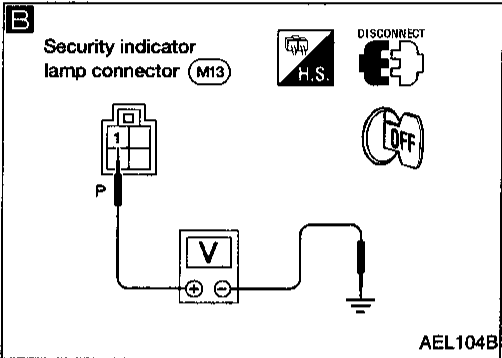
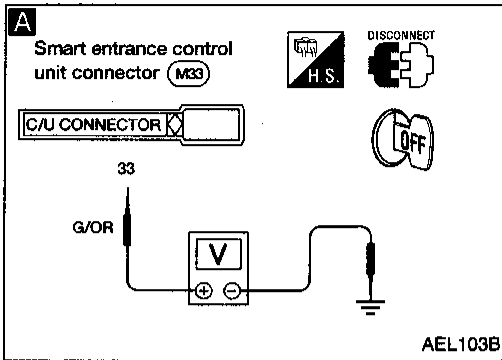

THEFT WARNING SYSTEM

Trouble Diagnoses (Cont'd)

DIAGNOSTIC PROCEDURE 3 (Door unlock sensor check)

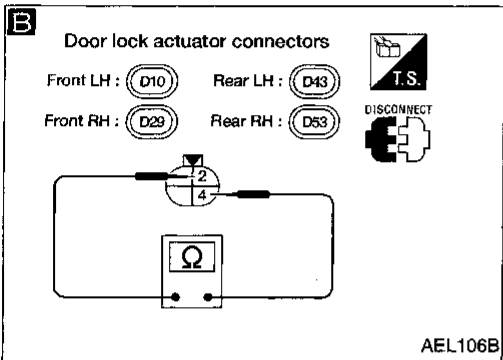
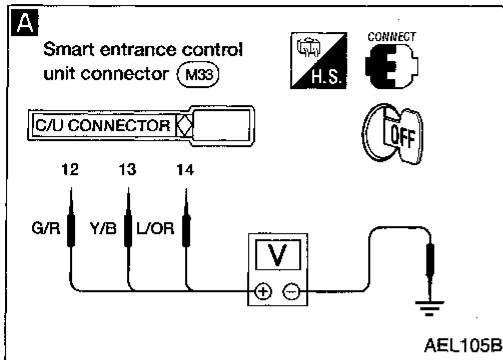

A

CHECK DOOR UNLOCK SENSOR INPUT SIGNAL.
Check voltage between control unit terminals (12), (13) or (14) and ground.

	Terminals		Condition	Voltage [V]
	⊕	⊖		
Front LH door	(12)	Ground	Locked	Approx. 12
			Unlocked	0
Front RH door	(13)	Ground	Locked	Approx. 12
			Unlocked	0
Rear door	(14)	Ground	Locked	Approx. 12
			Unlocked	0

Refer to wiring diagram in EL-204.

OK → Door unlock sensor is OK.

B

CHECK DOOR UNLOCK SENSOR.
1. Disconnect door unlock sensor connector.
2. Check continuity between door unlock sensor terminals.

Terminals	Condition	Continuity
(4) - (2)	Locked	No
	Unlocked	Yes

NG → Replace door unlock sensor.

OK →

Check the following.

- Door unlock sensor ground circuit
- Harness for open or short between control unit and door unlock sensor

GI

MA

EM

LC

EC

FE

CL

MT

AT

FA

RA

BR

ST

RS

BT

HA

EL

IDX

THEFT WARNING SYSTEM

Trouble Diagnoses (Cont'd)

DIAGNOSTIC PROCEDURE 4 (Door key cylinder switch check)

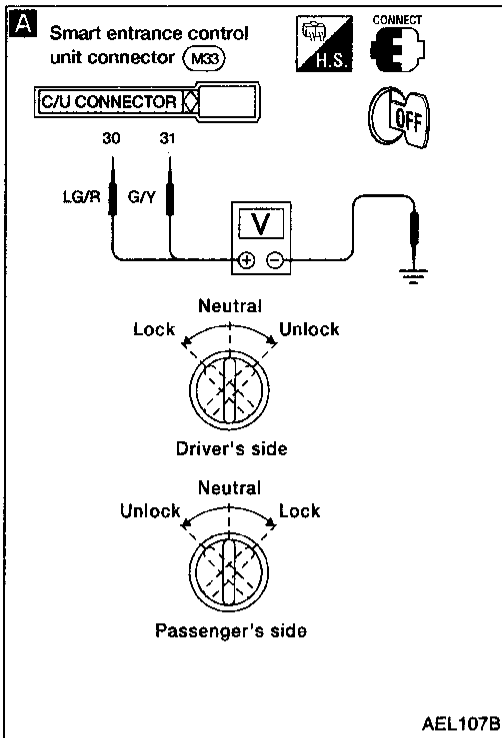

A

CHECK DOOR KEY CYLINDER SWITCH INPUT SIGNAL (LOCK/UNLOCK SIGNAL).

Check voltage between control unit terminals ③⑩ or ③⑪ and ground.

Terminals		Key position	Voltage [V]
⊕	⊖		
③⑩	Ground	Neutral	Approx. 12
		Lock	0
③⑪	Ground	Neutral	Approx. 12
		Unlock	0

Refer to wiring diagram in EL-206.

OK

Door key cylinder switch is OK.

NG

B

CHECK DOOR KEY CYLINDER SWITCH.

1. Disconnect door key cylinder switch connector.
2. Check continuity between door key cylinder switch terminals.

Terminals	Key position	Continuity
LH: ① - ②	Neutral	No
RH: ③ - ②	Lock	Yes
LH: ③ - ②	Neutral	No
RH: ① - ②	Unlock	Yes

NG

Replace door key cylinder switch.

OK

Check the following:

- Door key cylinder switch ground circuit
- Harness for open or short between control unit and door key cylinder switch

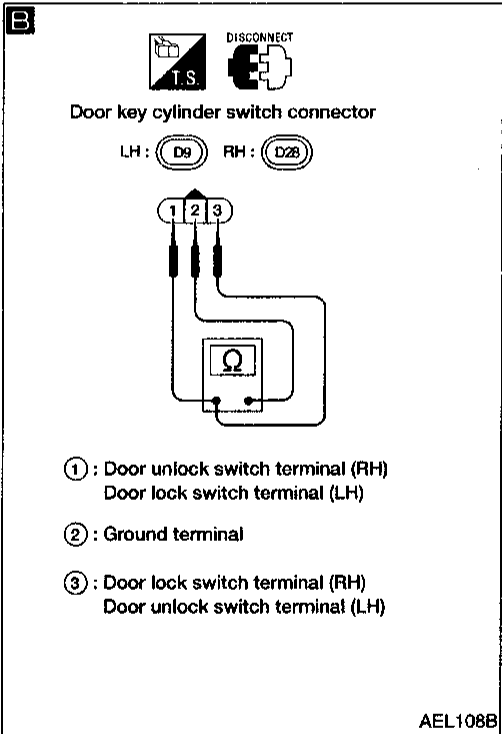

THEFT WARNING SYSTEM

Trouble Diagnoses (Cont'd)

DIAGNOSTIC PROCEDURE 5

(Trunk lid key cylinder switch check)

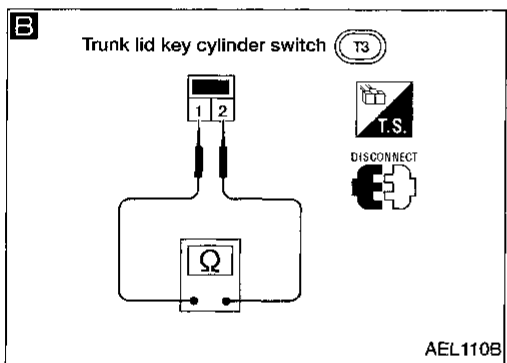
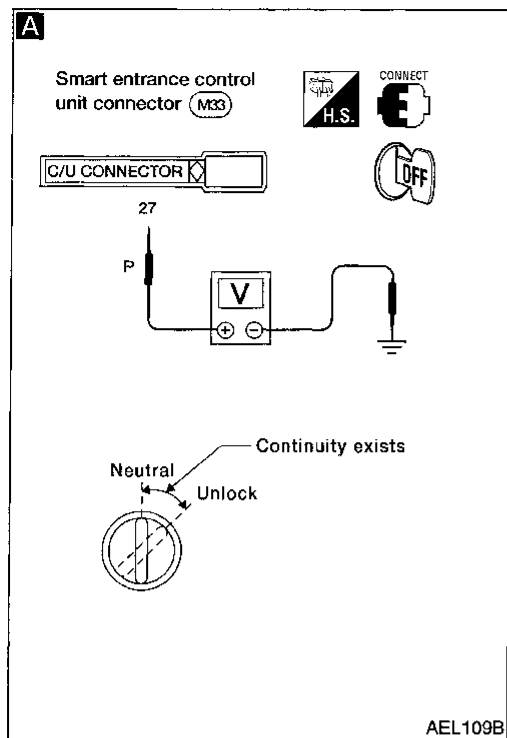

A

CHECK TRUNK LID KEY CYLINDER SWITCH INPUT SIGNAL (UNLOCK SIGNAL).

Check voltage between control unit terminal (27) and ground.

Key position	Voltage [V]
Neutral	Approx. 12
Between neutral and unlock	0

Refer to wiring diagram in EL-206.

OK → Trunk lid key cylinder switch is OK.

B

CHECK TRUNK LID KEY CYLINDER SWITCH.

1. Disconnect trunk lid key cylinder switch connector.
2. Check continuity between trunk lid key cylinder switch terminals.

Key position	Continuity
Neutral and lock	No
Between neutral and unlock	Yes

NG → Replace trunk lid key cylinder switch.

OK

Check the following:

- Trunk lid key cylinder switch ground circuit
- Harness for open or short between control unit and trunk lid key cylinder switch

GI
MA
EM
LC
EC
FE
CL
MT
AT
FA
RA
BR
ST
RS
BT
HA
EL
IDX

THEFT WARNING SYSTEM

Trouble Diagnoses (Cont'd)

DIAGNOSTIC PROCEDURE 6 (Theft warning horn alarm check)

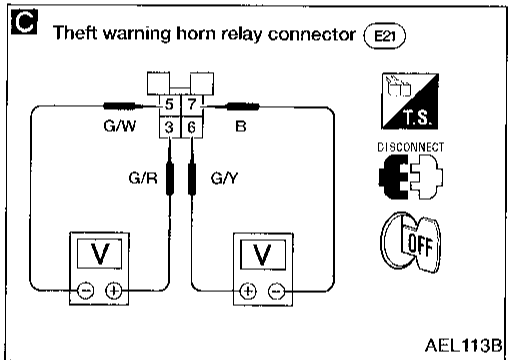
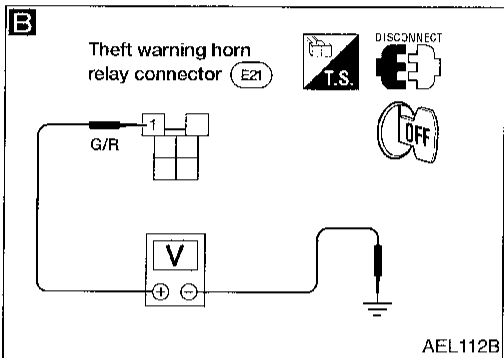
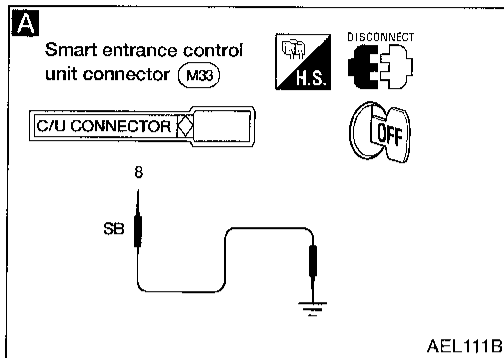

A

CHECK THEFT WARNING HORN ALARM OPERATION.

1. Disconnect control unit connector.
2. Apply ground to control unit terminal (8).

Does horn alarm activate?

Refer to wiring diagram in EL-207.

Yes → Horn alarm is OK.

No

Check theft warning horn relay.

NG → Replace.

OK

B

CHECK POWER SUPPLY FOR THEFT WARNING HORN RELAY.

1. Disconnect theft warning horn relay connector.
2. Check voltage between terminal (1) and ground.

Battery voltage should exist.

NG → Check the following:
 ● 10A fuse (No. 41), located in the fuse and fusible link box
 ● Harness for open or short between theft warning horn relay and fuse

OK

C

CHECK THEFT WARNING HORN RELAY CIRCUIT.

1. Disconnect theft warning horn relay connector.
2. Check voltage between terminals (3) and (5).
3. Check voltage between terminals (6) and (7).

Battery voltage should exist.

NG → Check harness for open or short.

OK

Check harness for open or short between theft warning horn relay and control unit.

THEFT WARNING SYSTEM

Trouble Diagnoses (Cont'd)

DIAGNOSTIC PROCEDURE 7

(Theft warning headlamp alarm check)

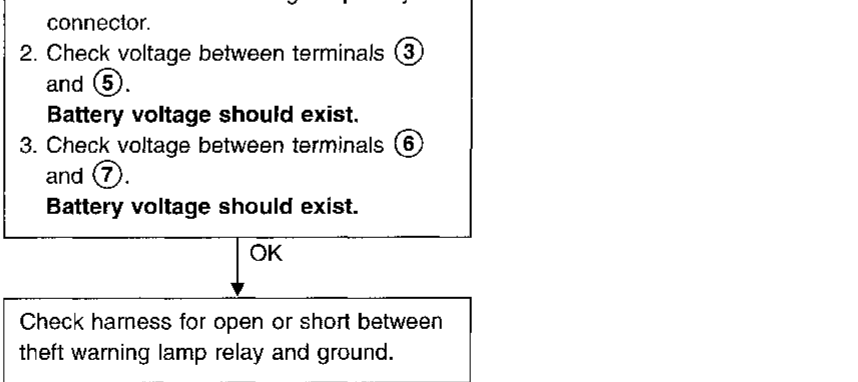
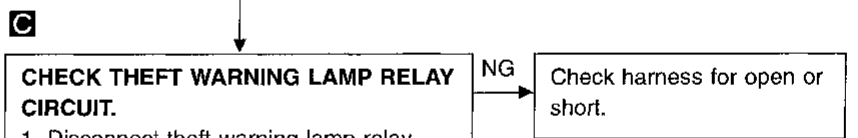
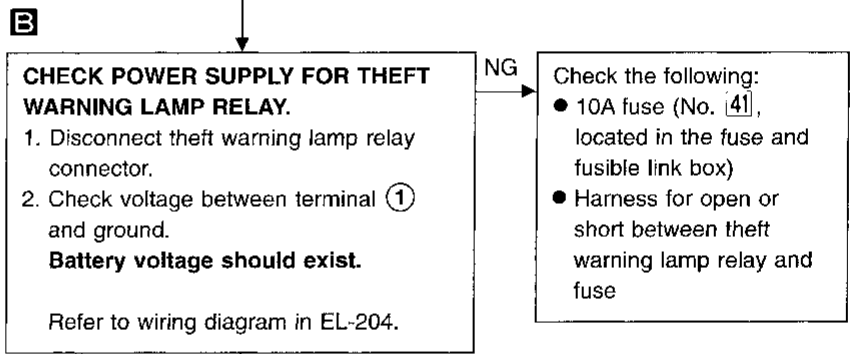
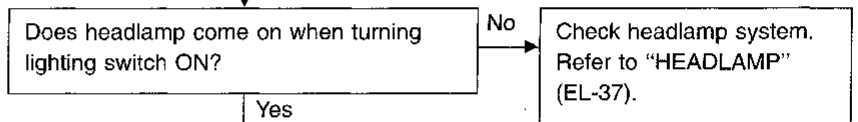
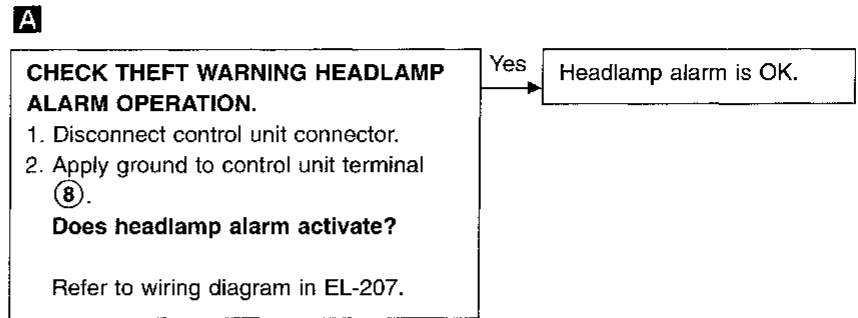
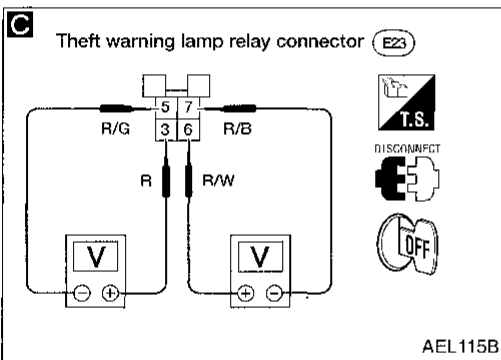
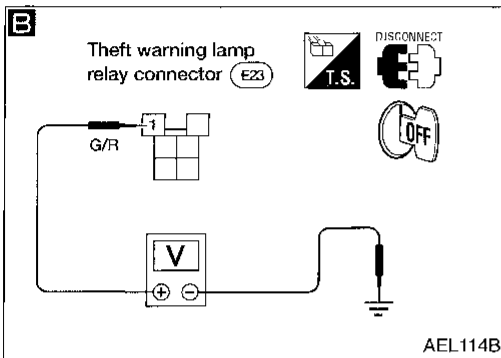
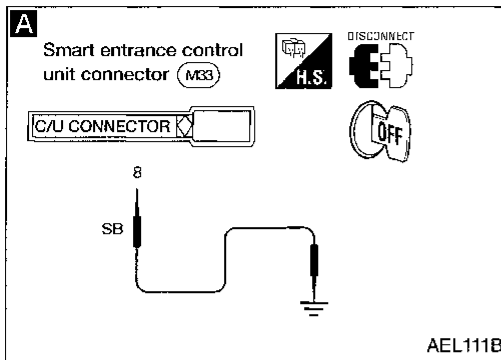

G1
MA
EM
LC
EC
FE
CL
MT
AT
FA
RA
BR
ST
RS
BT
HA
EL
IDX

THEFT WARNING SYSTEM

Trouble Diagnoses (Cont'd)

DIAGNOSTIC PROCEDURE 8

(Starter interrupt system check)

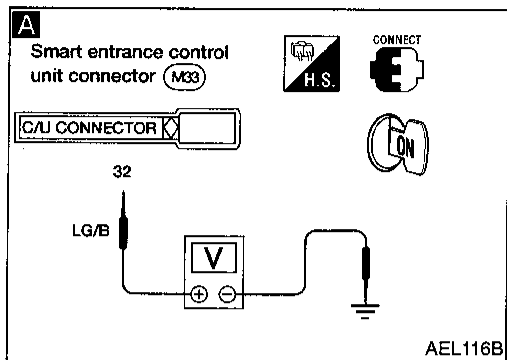

A

CHECK STARTER MOTOR INTERRUPT SIGNAL.

1. Turn ignition switch ON.
2. Check voltage between control unit terminal (32) and ground.

Condition	Voltage [V]
Except starter interrupted phase	Approx. 12
Starter interrupted phase	0

Refer to wiring diagram in EL-206.

NG

Check the following:

- 10A fuse [No. 25], located in fuse block (J/B)]
- Harness for open or short between theft warning relay terminal and fuse
- Harness for open or short between control unit terminal and theft warning relay terminal

OK

Check theft warning relay.

NG

Replace relay.

OK

Check starting system. Refer to "STARTING SYSTEM" (EL-206).

SMART ENTRANCE CONTROL UNIT

Description

The following systems are controlled by the smart entrance control unit.

- Warning chime
- Rear window defogger timer
- Power door lock
- Multi-remote control system
- Theft warning system.

For detailed description and wiring diagrams, refer to the relevant pages for the each system.

The control unit receives data from the switches and sensors to control their corresponding system relays and actuators.

System	Input	Output
Power door lock	Door lock and unlock switches	Door lock actuators
Multi-remote control	Key switch (Insert) Ignition switch (ACC) Door switch Door unlock sensors Antenna (remote controller signal)	Theft warning horn relay Theft warning lamp relay Interior lamp Multi-remote control relay-1 Door lock actuators
Warning chime	Key switch (Insert) Ignition switch (ON) Lighting switch (1st) Seat belt buckle switch Front door switch LH	Warning chime
Rear window defogger timer	Ignition switch (ON) Rear window defogger switch	Rear window defogger relay
Theft warning	Ignition switch (ACC, ON) Door switches Hood switch Trunk room lamp switch Door key cylinder switches (lock/unlock) Trunk lid key cylinder switch (unlock) Door unlock sensors	Theft warning horn relay Theft warning lamp relay Theft warning relay (Starter interrupt) Security indicator

GI

MA

EM

LC

EC

FE

CL

MT

AT

FA

RA

BR

ST

RS

BT

HA

EL

IDX

SMART ENTRANCE CONTROL UNIT

Input/Output Operation Signal

Terminal No.	Connections	Operated condition	Voltage (V) (Approximate values)
1	Power source (C/B)	—	12V
2	Passenger door lock actuator	Door lock & unlock switch	Unlocked
3	Driver door lock actuator		Free
4	Driver and passenger door lock actuators	Door lock & unlock switch	Locked
			Free
7	Multi-remote control relay-1	When doors are locked using remote controller	12V → 0V
8	Theft warning horn relay	When panic alarm is operated using remote controller	12V → 0V
9	Interior lamp	When interior lamp is operated using remote controller. (Lamp switch in "DOOR" position)	12V → 0V
10	Ground	—	—
11	Ignition switch (ON)	Ignition key is in "ON" position	12V
12	Driver door unlock sensor	Driver door: Locked → Unlocked	12V → 0V
13	Passenger door unlock sensor	Passenger door: Locked → Unlocked	12V → 0V
14	Rear door unlock sensor	Rear door LH & RH: Locked → Unlocked	12V → 0V
15	Driver door switch	OFF (Closed) → ON (Open)	12V → 0V
16	Passenger door switch	OFF (Closed) → ON (Open)	12V → 0V
17	Ignition switch (ACC)	"ACC" position	12V
18	Door key cylinder switches (lock)	Neutral → Locks	12V → 0V
19	Door key cylinder switches (unlock)	Neutral → Unlocks	12V → 0V
20	Rear window defogger switch	OFF → ON	12V → 0V
21	Seat belt buckle switch	Unfasten → Fasten (Ignition key is in "ON" position)	0V → 12V
23	Warning chime	OFF → ON	12V → 0V
24	Ignition key switch (Insert)	IGN key inserted → IGN key removed from IGN key cylinder	12V → 0V
25	Lighting switch (1ST)	1ST, 2ND positions: ON → OFF	12V → 0V
26	Trunk room lamp switch	ON (Open) → OFF (Closed)	0V → 12V
27	Trunk lid key cylinder switch (unlock)	OFF (Neutral) → ON (Unlocked)	12V → 0V
29	Hood open signal	ON (Open) → OFF (Closed)	0V → 12V
30	Door key cylinder lock switch	OFF (Neutral) → ON (Locked)	12V → 0V
31	Door key cylinder lock switch	OFF (Neutral) → ON (Unlocked)	12V → 0V
32	Theft warning relay (Starter cut)	OFF → ON (Ignition key is in "ON" position)	12V → 0V
33	Theft warning indicator	Goes off → Illuminates	12V → 0V
36	Rear defogger relay	OFF → ON (Ignition key is in "ON" position)	12V → 0V

SMART ENTRANCE CONTROL UNIT

NOTES

GI

MA

EM

LC

EC

FE

CL

MT

AT

FA

RA

BR

ST

RS

BT

HA

EL

IDX

SMART ENTRANCE CONTROL UNIT

Schematic

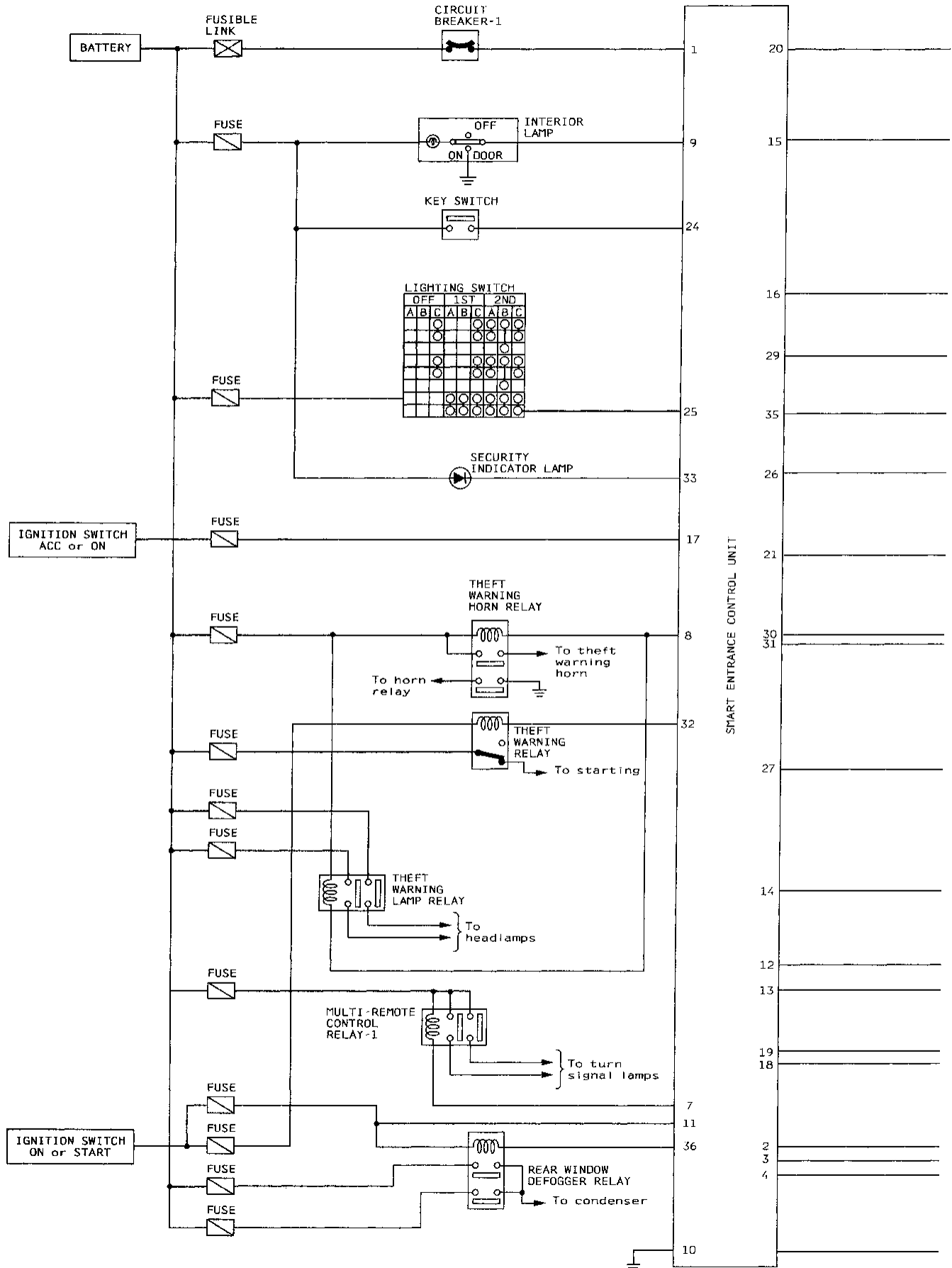

AEL996A

SMART ENTRANCE CONTROL UNIT

Schematic (Cont'd)

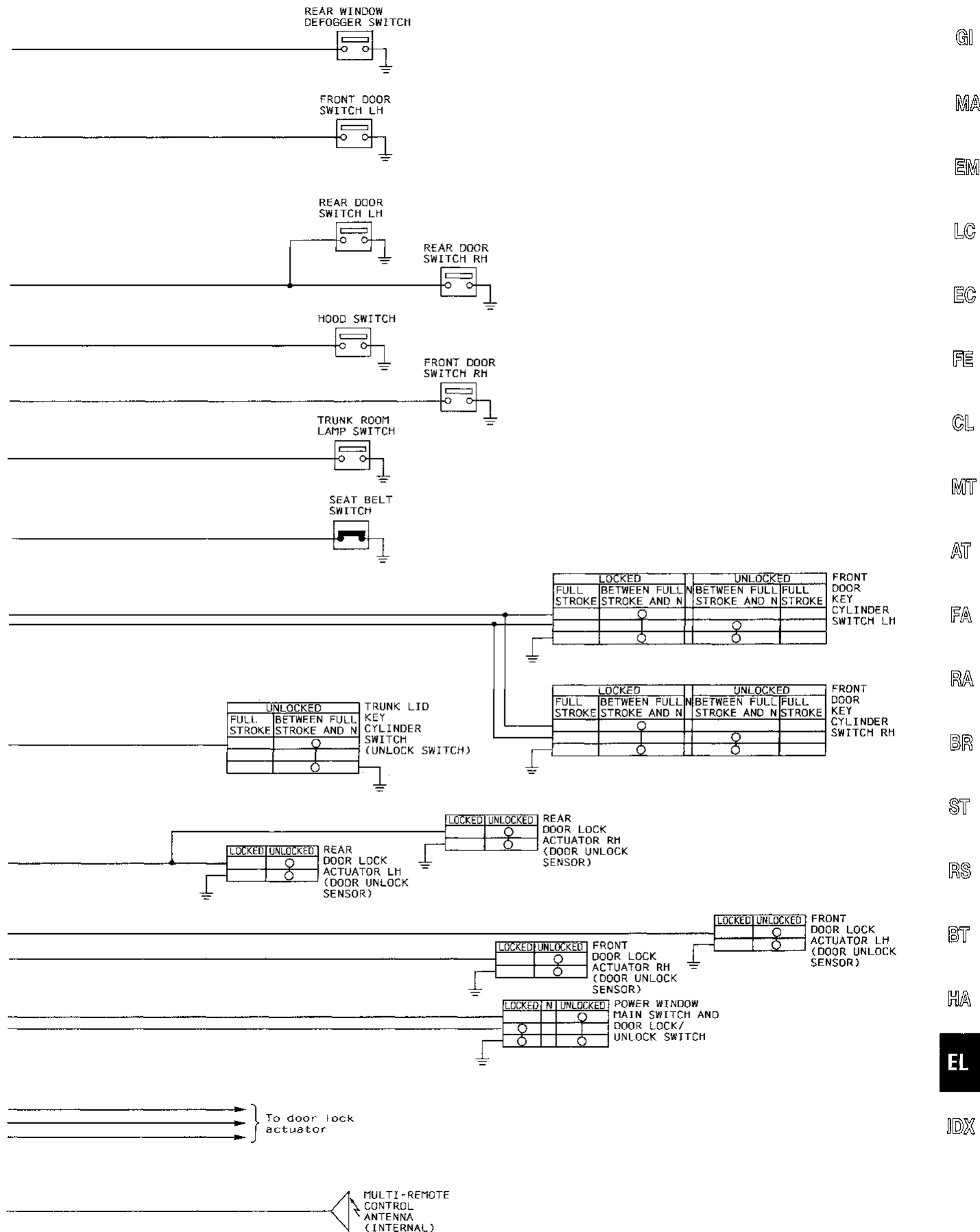

GI
MA
EM
LC
EC
FE
CL
MT
AT
FA
RA
BR
ST
RS
BT
HA
EL
IDX

LOCATION OF ELECTRICAL UNITS

Engine Compartment

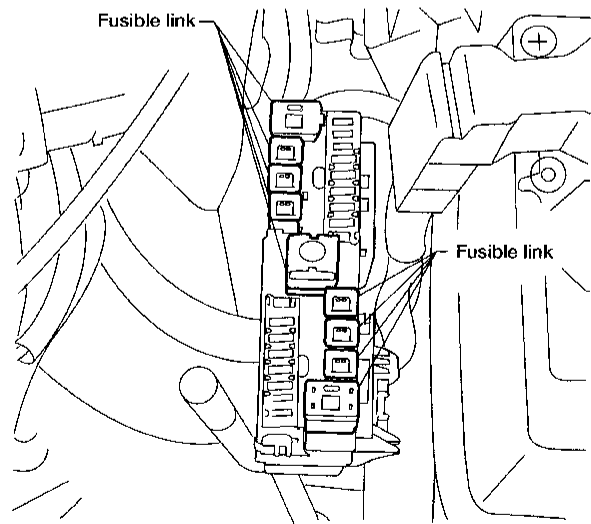
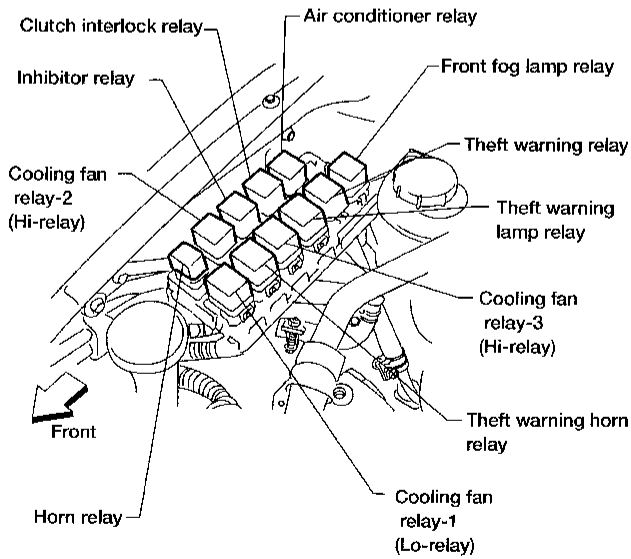
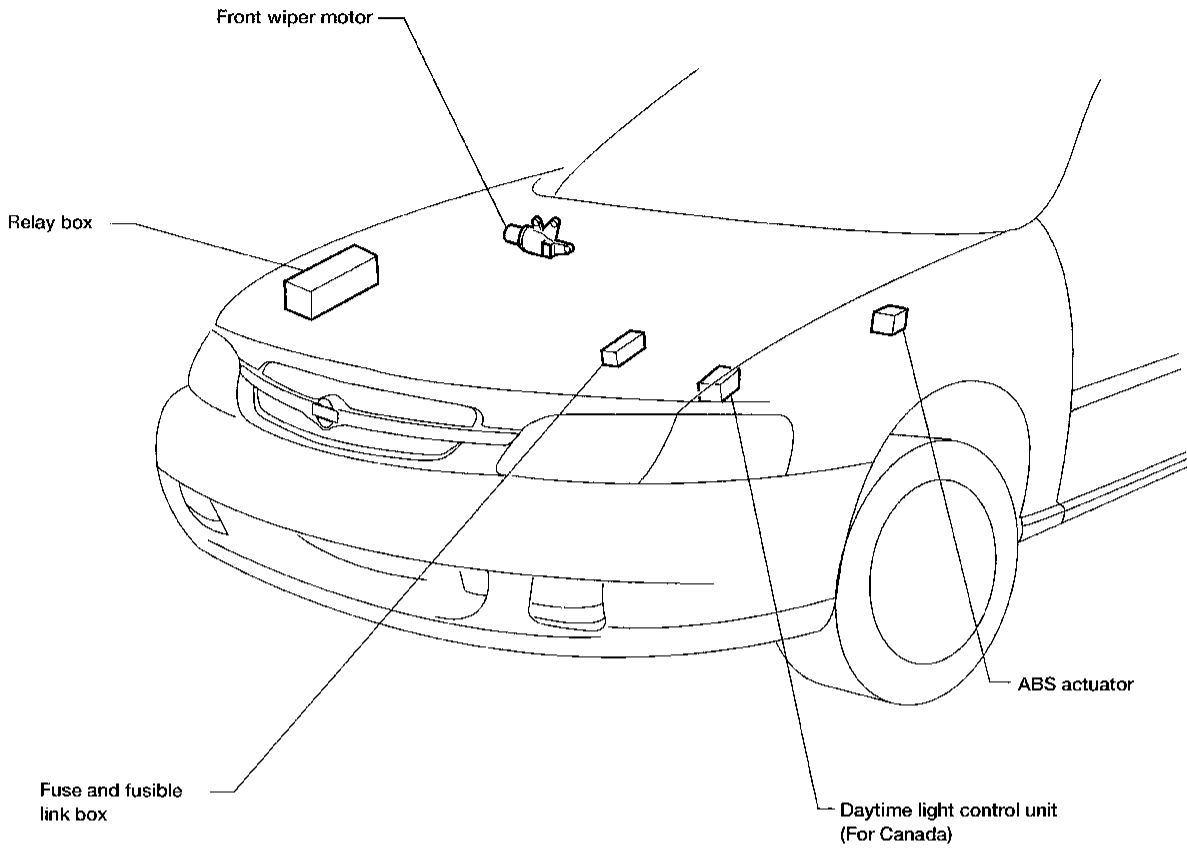

LOCATION OF ELECTRICAL UNITS

NOTES

GI

MA

EM

LC

EC

FE

CL

MT

AT

FA

RA

BR

ST

RS

BT

HA

EL

IDX

LOCATION OF ELECTRICAL UNITS

Passenger Compartment

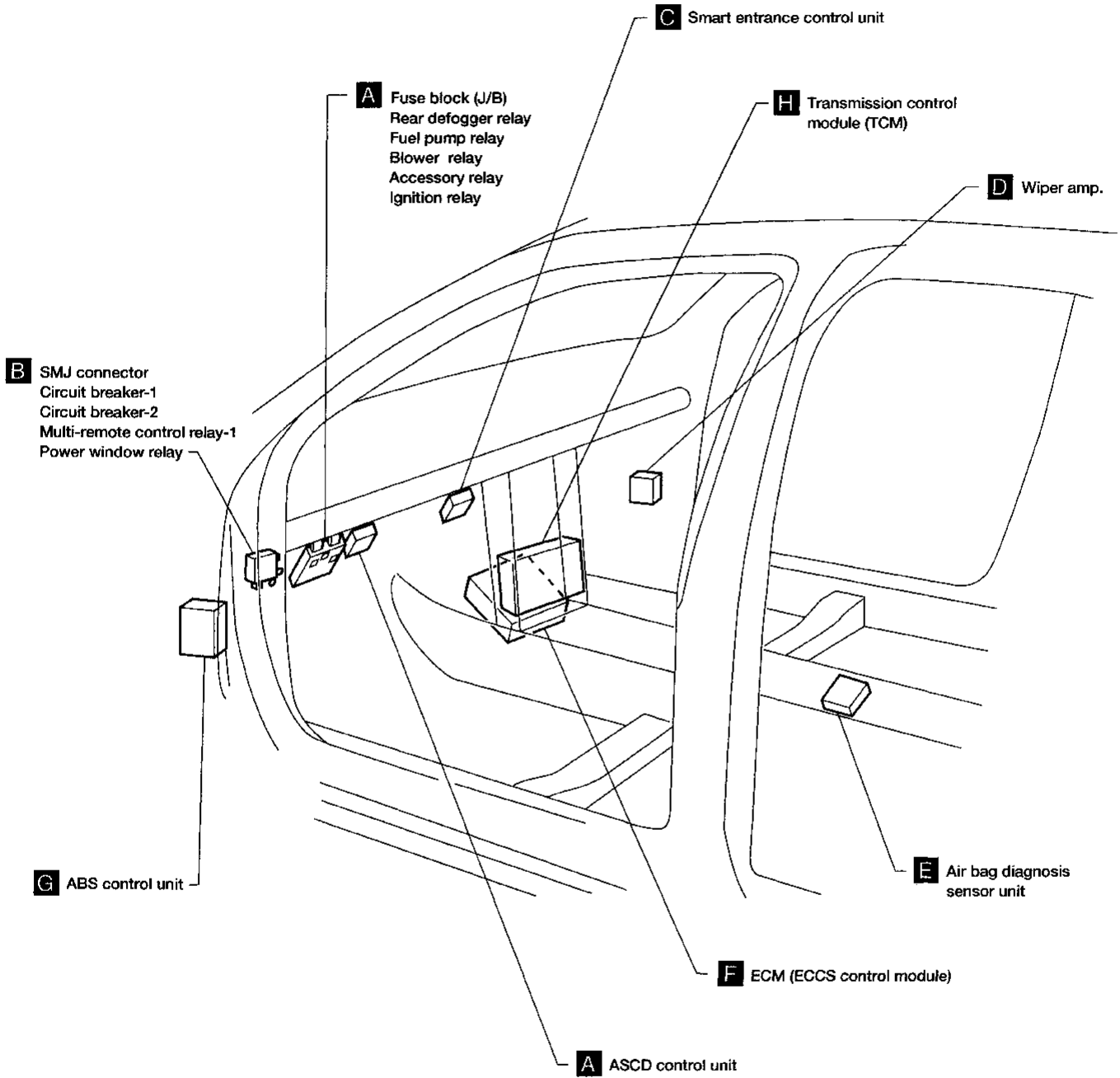

LOCATION OF ELECTRICAL UNITS

Passenger Compartment (Cont'd)

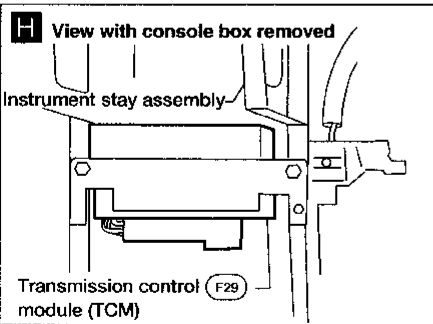
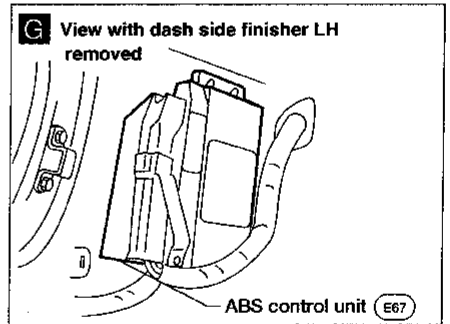
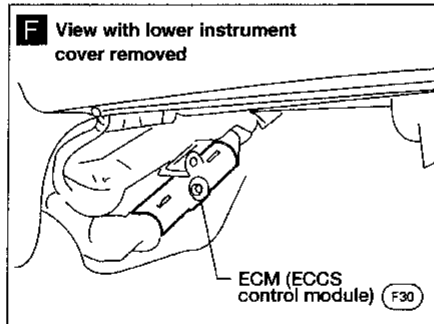
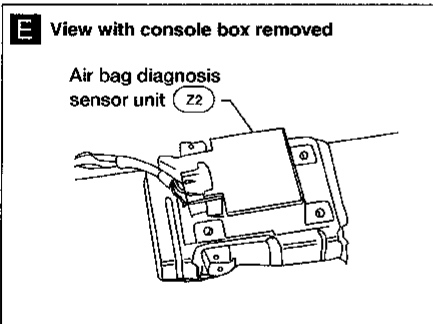
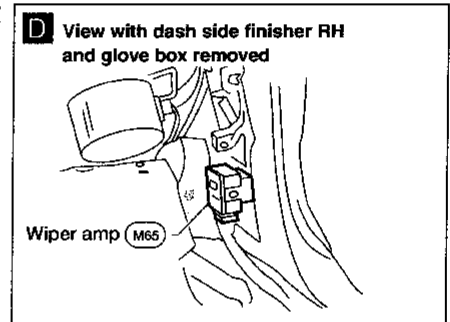
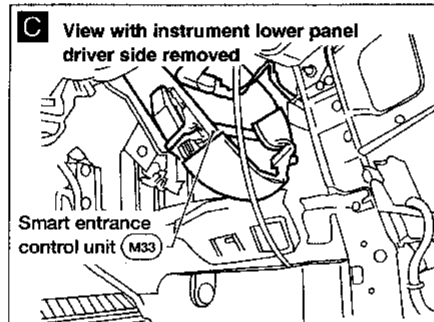
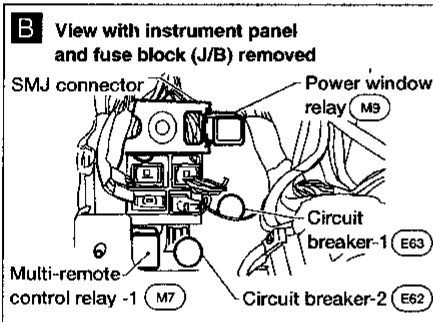
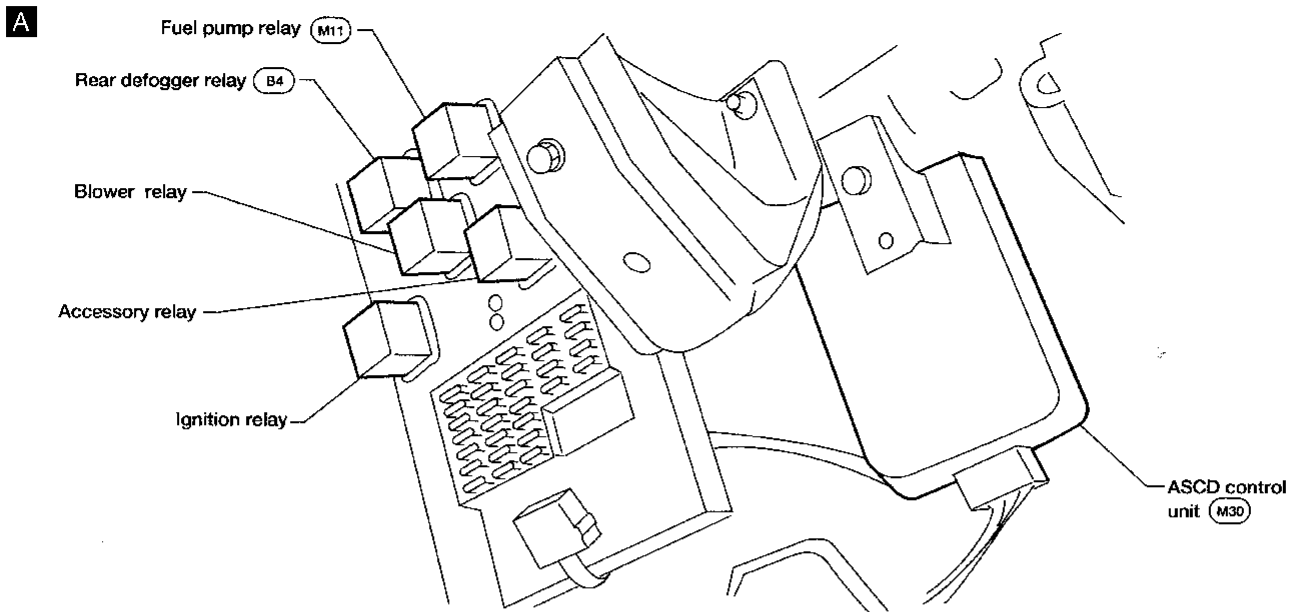

GI
 MA
 EM
 LC
 EC
 FE
 CL
 MT
 AT
 FA
 RA
 BR
 ST
 RS
 BT
 HA
EL
 IDX

HARNES LAYOUT

Outline

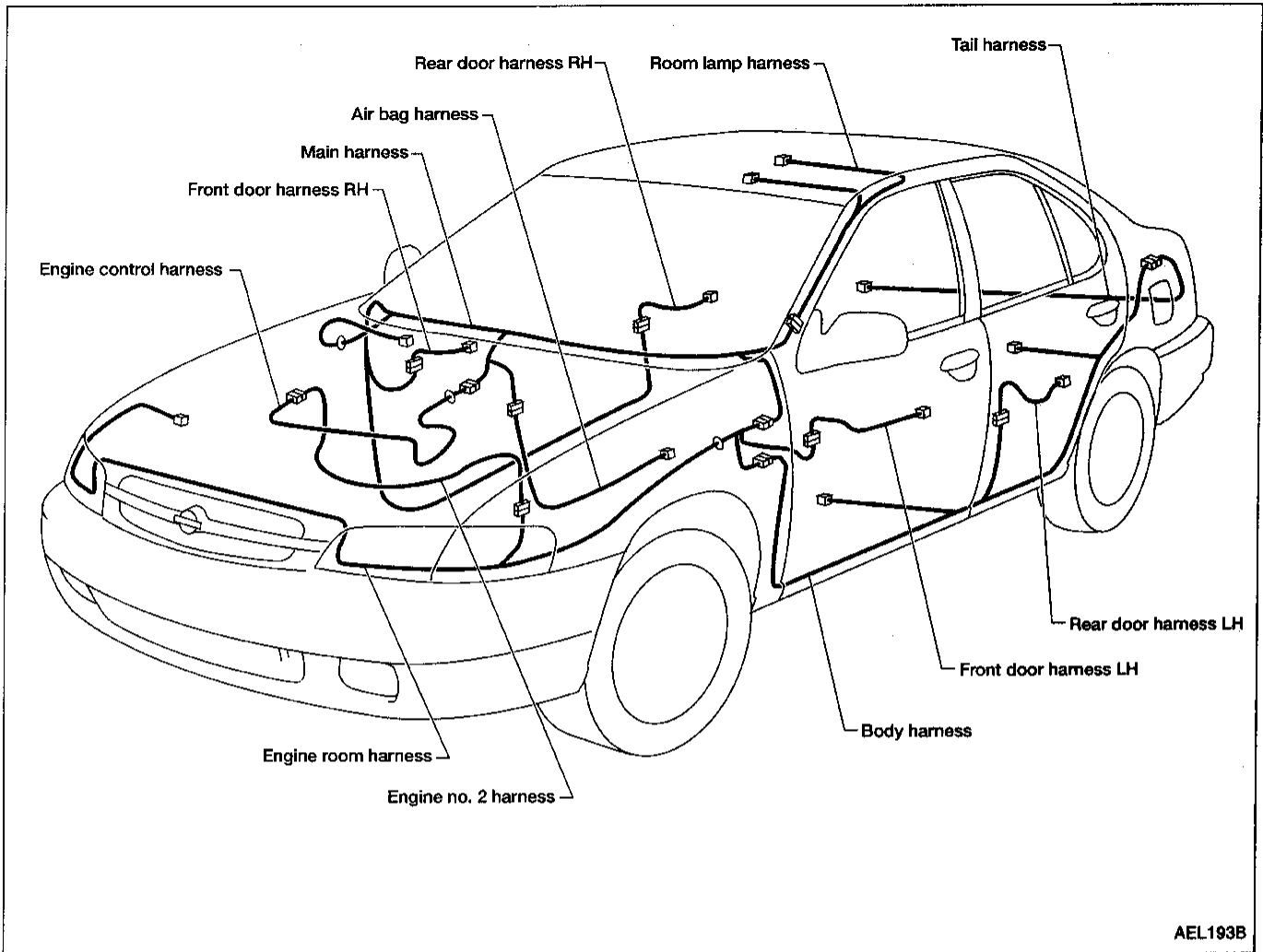

HARNESS LAYOUT

How to Read Harness Layout

Example:

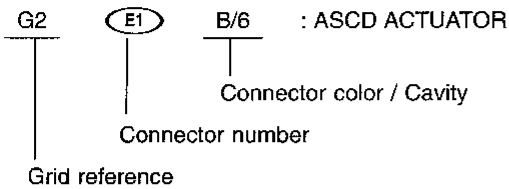

The following Harness Layouts use a map style grid to help locate connectors on the drawings:

- Main Harness
- Engine Room Harness (Engine Compartment)
- Engine Control Harness
- Body Harness

To use the grid reference

- 1) Find the desired connector number on the connector list.
- 2) Find the grid reference.
- 3) On the drawing, find the crossing of the grid reference letter column and number row.
- 4) Find the connector number in the crossing zone.
- 5) Follow the line (if used) to the connector.

CONNECTOR SYMBOL

Main symbols of connector (in Harness Layout) are indicated in the below.

Connector type	Water proof type		Standard type	
	Male	Female	Male	Female
<ul style="list-style-type: none"> ● Cavity: Less than 4 ● Relay connector 				
<ul style="list-style-type: none"> ● Cavity: From 5 to 8 				
<ul style="list-style-type: none"> ● Cavity: More than 9 				
<ul style="list-style-type: none"> ● Ground terminal etc. 	—			

GI

MA

EM

LC

EC

FE

CL

MT

AT

FA

RA

BR

ST

RS

BT

HA

EL

IDX

HARNESS LAYOUT

Main Harness

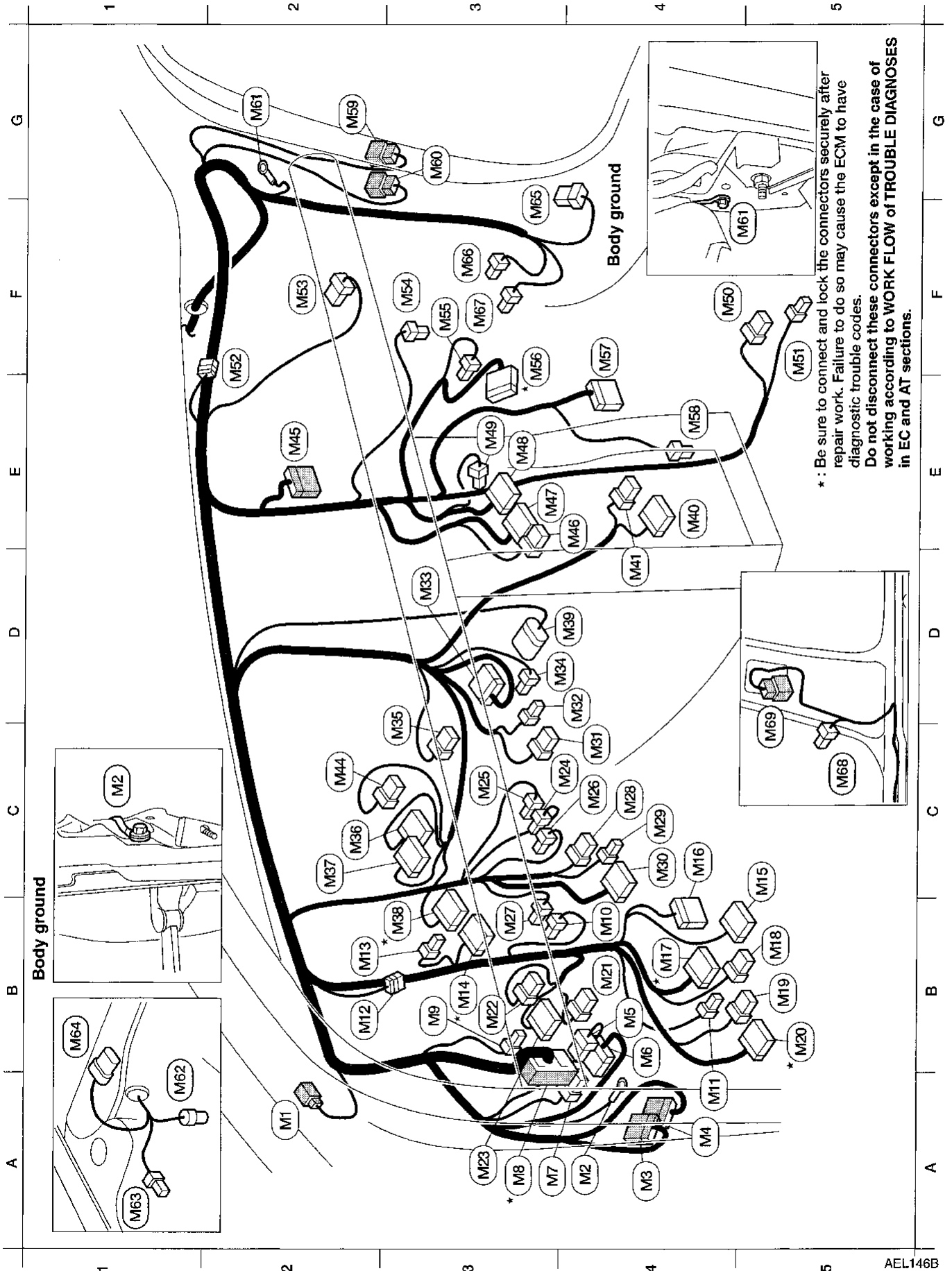

* : Be sure to connect and lock the connectors securely after repair work. Failure to do so may cause the ECM to have diagnostic trouble codes.
 Do not disconnect these connectors except in the case of working according to **WORK FLOW of TROUBLE DIAGNOSES** in EC and AT sections.

HARNESS LAYOUT

Main Harness (Cont'd)

A2	(M1) W/4	: To (R1)	E3	(M49) B/2	: Full cool switch
A4	(M2) —	: Body ground	F4	(M50) W/6	: A/T device
A4	(M3) W/12	: To (D1)	F5	(M51) B/1	: Parking brake switch
A4	(M4) W/12	: To (D2)	F2	(M52) SB/4	: Diode
B4	(M5) W/8	: To (E5)	F2	(M53) W/8	: Intake door motor
B4	(M6) W/20	: To (E6)	F3	(M54) B/2	: Glove box lamp
A3	(M7) BR/6	: Multi-remote control relay-1	F3	(M55) W/3	: Thermo control amplifier
A3 *	(M8) SMJ	: To (E8)	F3 *	(M56) W/18	: To (E28)
B3	(M9) L/4	: Power window relay	F4	(M57) W/20	: To (E27)
B4	(M10) L/2	: ASCD clutch switch	E4	(M58) B/2	: Cigarette lighter socket
A4	(M11) L/4	: Fuel pump relay	G2	(M59) W/6	: To (D20)
B2	(M12) W/2	: Diode	G3	(M60) W/8	: To (D21)
B2	(M13) W/4	: Security indicator lamp	G2	(M61) —	: Body ground
B3 *	(M14) B/12	: Combination meter	A1	(M62) GY/2	: Front wheel sensor RH
C5	(M15) GY/14	: Data link connector for CONSULT	A1	(M63) B/1	: Theft warning horn
C4	(M16) W/16	: Data link connector for GST	B1	(M64) GY/6	: Wiper motor
B4 *	(M17) GY/16	: Fuse block (J/B)	F3	(M65) W/8	: Wiper amplifier
B5	(M18) GY/8	: Fuse block (J/B)	F3	(M66) W/2	: Blower motor
B5	(M19) W/8	: Fuse block (J/B)	F3	(M67) BR/4	: Fan resistor
B5 *	(M20) BR/16	: Fuse block (J/B)	C5	(M68) BR/1	: Front door switch RH
B4	(M21) W/6	: Illumination control switch	D5	(M69) W/8	: To (D50)
B3	(M22) W/6	: ASCD main switch			
A3	(M23) GY/12	: Door mirror remote control switch			
C3	(M24) L/2	: ASCD brake switch			
C3	(M25) B/2	: Stop lamp switch			
C4	(M26) L/2	: A/T shift lock switch (ASCD brake switch)			
B3	(M27) L/2	: Clutch interlock switch			
C4	(M28) BR/6	: ASCD hold relay (A/T)			
C4	(M29) L/4	: ASCD hold relay (M/T)			
C4	(M30) B/20	: ASCD control unit			
C4	(M31) W/8	: Warning chime unit			
D4	(M32) W/4	: Rear window defogger timer			
D3	(M33) W/36	: Smart entrance control unit			
D3	(M34) B/3	: Combination flasher unit			
D3	(M35) W/6	: Rear window defogger switch			
C2	(M36) W/10	: Combination meter			
C2	(M37) B/10	: Combination meter			
B3 *	(M38) W/12	: Combination meter			
D4	(M39) BR/10	: Mode door motor			
E4	(M40) W/10	: Radio and cassette player			
D4	(M41) W/6	: Radio and cassette player			
C2	(M44) W/8	: Hazard switch			
E2	(M45) W/12	: To (Z3)			
E4	(M46) W/6	: Fan switch			
E3	(M47) B/20	: Push control unit			
E3	(M48) B/16	: Push control unit			

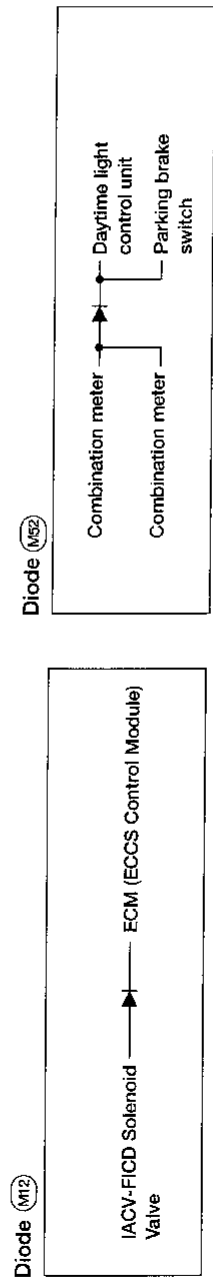

* : Be sure to connect and lock the connectors securely after repair work. Failure to do so may cause the ECM to have diagnostic trouble codes.
Do not disconnect these connectors except in the case of working according to WORK FLOW of TROUBLE DIAGNOSES in EC and AT sections.

- EL
- IDX
- BT
- RS
- ST
- BR
- RA
- FA
- AT
- MT
- CL
- FE
- EC
- LC
- EM
- MA
- GI

HARNESS LAYOUT

Engine Room Harness

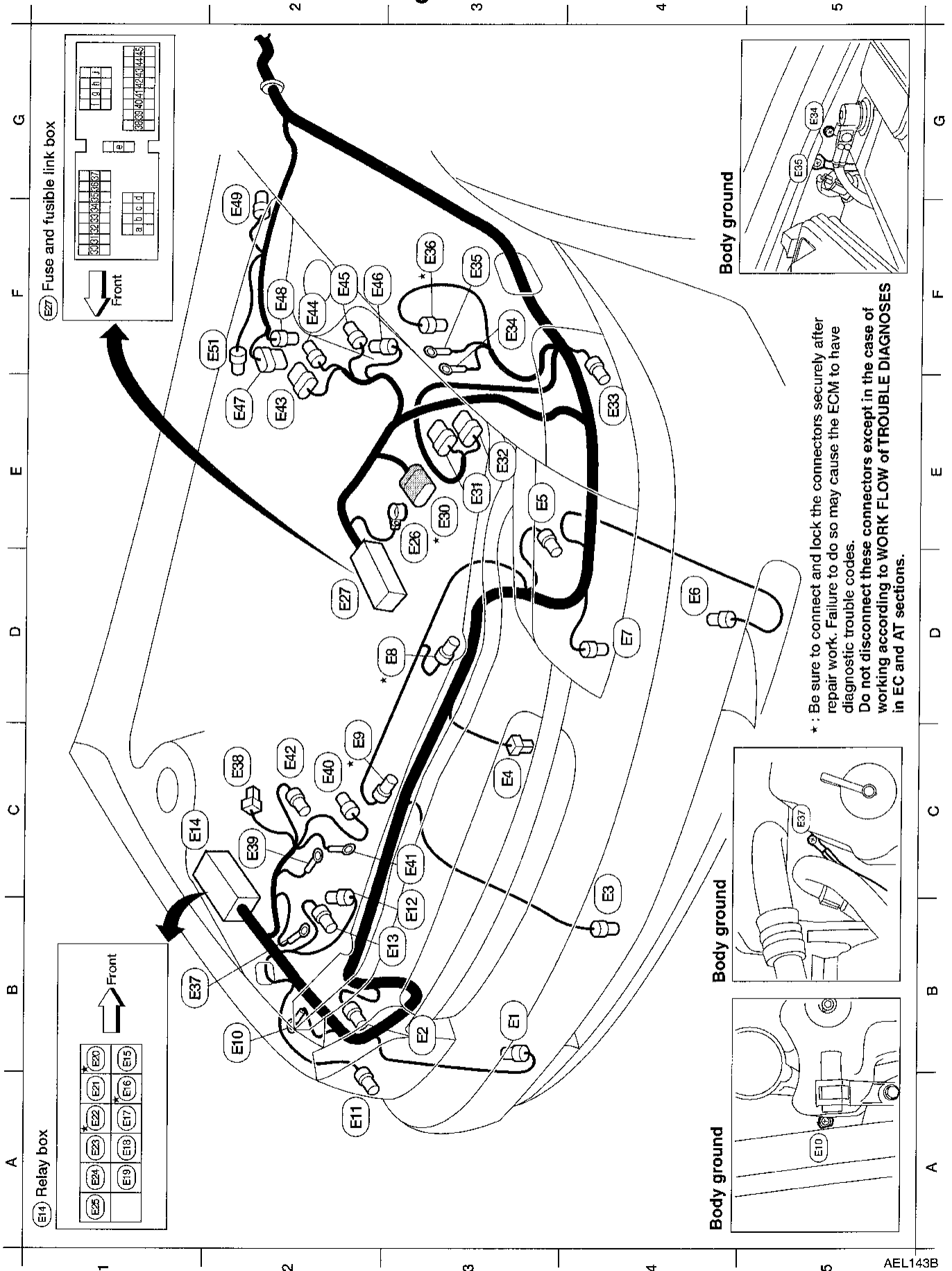

HARNESS LAYOUT

Engine Room Harness (Cont'd)

B3	E1	B/2	: Front fog lamp RH	E3	E26	—	: Battery
B3	E2	B/3	: Headlamp RH	D2	E27	—	: Fuse and fusible link box
C4	E3	GY/2	: Ambient temperature switch	E3 *	E30	GY/9 : To E20	
C3	E4	B/1	: Horn	E3	E31	GY/6	: Daytime light control unit (For Canada)
E3	E5	B/3	: Headlamp LH	E3	E32	GY/8	: Daytime light control unit (For Canada)
D4	E6	B/2	: Front fog lamp LH	E4	E33	BR/3	: Front combination lamp LH
D4	E7	B/4	: Triple pressure switch	F3	E34	—	: Body ground
D3 *	E8	GY/4	: Cooling fan motor-1	F3	E35	—	: Body ground
C2 *	E9	GY/4	: Cooling fan motor-2	F3 *	E36	GY/2	: Intake air temperature sensor
B2	E10	—	: Body ground	B1	E37	—	: Body ground
A2	E11	BR/3	: Front combination lamp RH	C2	E38	B/1	: Thermal transmitter
B3	E12	BR/2	: Washer fluid level switch	C2	E39	—	: Generator
B3	E13	GY/2	: Washer motor	C2	E40	B/1	: A/C compressor
C1	E14	—	: Relay box	C3	E41	—	: Generator
B1	E15	W/3	: Horn relay	C2	E42	W/2	: Generator
A1 *	E16	BR/6	: Cooling fan relay-2 (Hi-relay)	E2	E43	B/8	: ABS relay unit
A1	E17	GY/6	: Inhibitor relay	F2	E44	B/2	: ABS relay unit
A1	E18	L/4	: Clutch interlock relay	F2	E45	GY/2	: Dropping resistor
A1	E19	L/4	: Air conditioner relay	F2	E46	GY/2	: Hood switch
B1 *	E20	BR/6	: Cooling fan relay-1 (Lo-relay)	E2	E47	GY/8	: ABS actuator
A1	E21	BR/6	: Theft warning horn relay	F2	E48	BR/2	: Front wheel sensor LH
A1 *	E22	BR/6	: Cooling fan relay-3 (Hi-relay)	F2	E49	GY/4	: ASCD pump
A1	E23	BR/6	: Theft warning lamp relay	F2	E50	GY/2	: Brake fluid level switch
A1	E24	B/5	: Theft warning relay				
A1	E25	L/4	: Front fog lamp relay				

Relay box

* : Be sure to connect and lock the connectors securely after repair work. Failure to do so may cause the ECM to have diagnostic trouble codes.
Do not disconnect these connectors except in the case of working according to WORK FLOW of TROUBLE DIAGNOSES in EC and AT sections.

GI

MA

EM

LC

EC

FE

CL

MT

AT

FA

RA

BR

ST

RS

BT

HA

EL

IDX

HARNESS LAYOUT

Engine Room Harness (Cont'd)

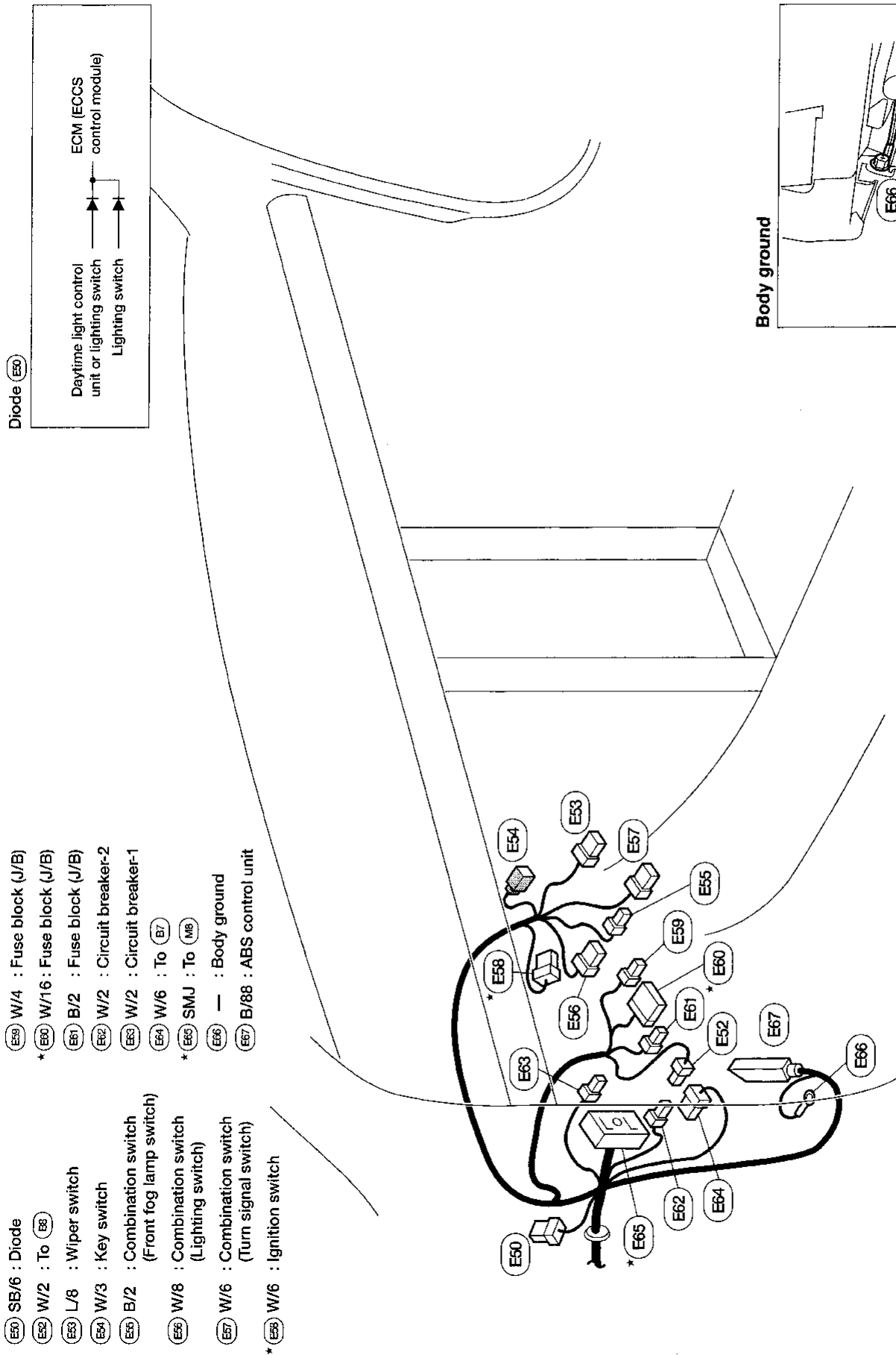

- (E59) W/4 : Fuse block (J/B)
- (E60) W/16 : Fuse block (J/B)
- (E61) B/2 : Fuse block (J/B)
- (E62) W/2 : Circuit breaker-2
- (E63) W/2 : Circuit breaker-1
- (E64) W/6 : To (B7)
- (E65) SMJ : To (MB)
- (E66) — : Body ground
- (E67) B/88 : ABS control unit

- (E50) SB/6 : Diode
- (E52) W/2 : To (E58)
- (E53) L/8 : Wiper switch
- (E54) W/3 : Key switch
- (E55) B/2 : Combination switch (Front fog lamp switch)
- (E56) W/8 : Combination switch (Lighting switch)
- (E57) W/6 : Combination switch (Turn signal switch)
- (E58) W/6 : Ignition switch

* : Be sure to connect and lock the connectors securely after repair work. Failure to do so may cause the ECM to have diagnostic trouble codes. Do not disconnect these connectors except in the case of working according to WORK FLOW of TROUBLE DIAGNOSES in EC and AT sections.

HARNESS LAYOUT

NOTES

GI

MA

EM

LC

EC

FE

CL

MT

AT

FA

RA

BR

ST

RS

BT

HA

EL

IDX

HARNESS LAYOUT

Engine Control Harness

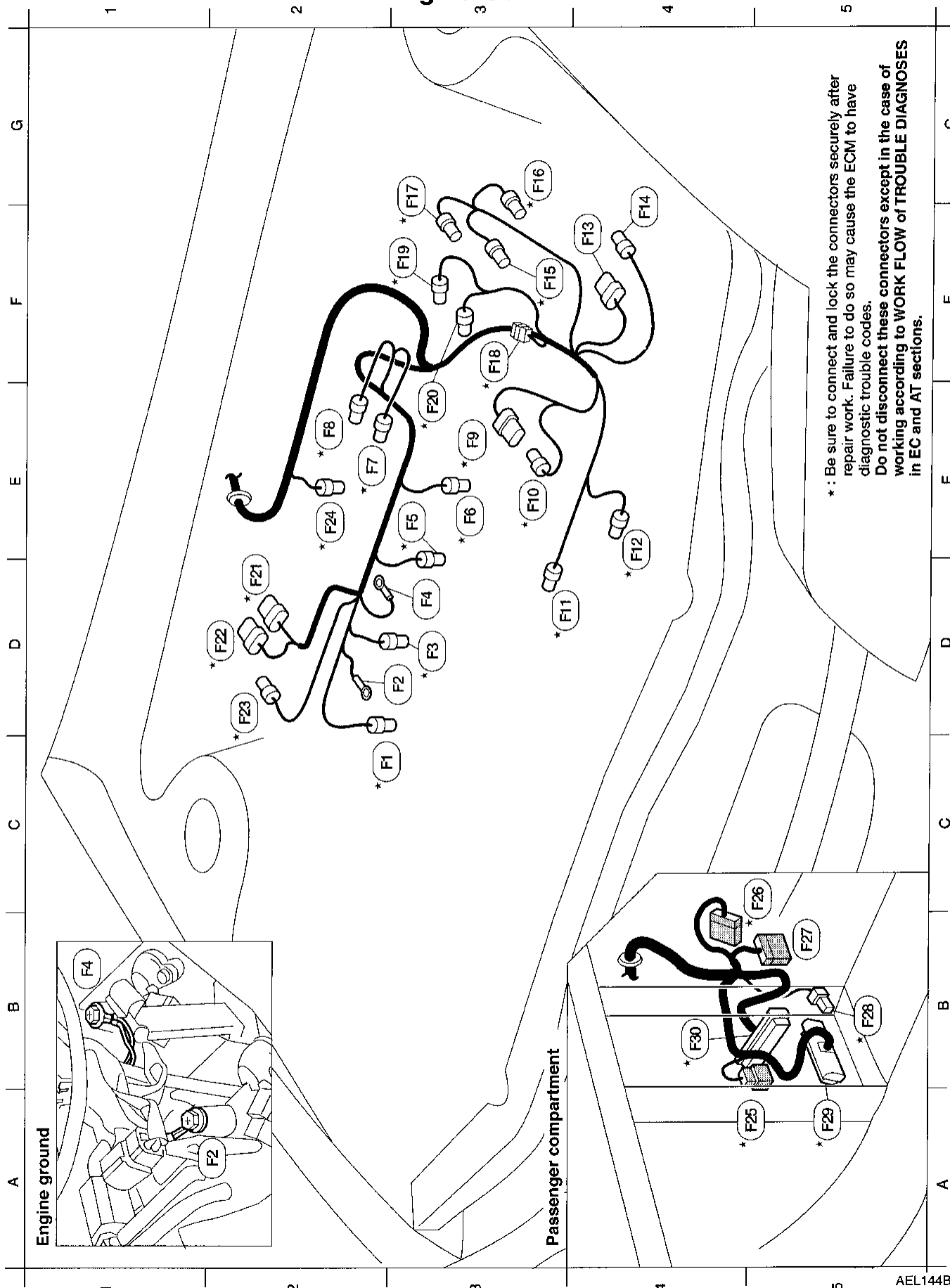

HARNESS LAYOUT

Engine Control Harness (Cont'd)

C2 * (F1) B/2 : Injector No. 1
 D3 (F2) — : Engine ground
 D3 * (F3) B/2 : Injector No. 2
 D3 (F4) — : Engine ground
 E3 * (F5) B/2 : Injector No. 3
 E3 * (F6) B/2 : Injector No. 4
 E2 * (F7) L/2 : EVAP canister purge
 volume control solenoid valve
 E2 * (F8) GY/2 : EGR temperature sensor
 E3 * (F9) GY/6 : Distributor (camshaft position sensor)
 E3 * (F10) GY/2 : Distributor
 D3 * (F11) GY/3 : Front heated oxygen sensor
 E4 * (F12) GY/2 : Crankshaft position sensor (OBD)
 F4 (F13) BR/8 : A/T solenoid valve
 F4 (F14) GY/3 : Revolution sensor
 F3 * (F15) BR/4 : Mass air flow sensor

G3 * (F16) G/2 : MAP/BARO switch solenoid valve
 G3 * (F17) GY/3 : Absolute pressure sensor
 F3 * (F18) GY/2 : Resistor
 F3 * (F19) BR/3 : Throttle position sensor
 E3 * (F20) GY/3 : Throttle position switch
 D2 * (F21) B/8 : To (E210)
 D2 * (F22) GY/6 : To (E208)
 D2 * (F23) G/2 : EGRC-solenoid valve
 E2 * (F24) GY/4 : Rear heated oxygen sensor
 A5 * (F25) W/8 : To (E1)
 C5 * (F26) W/18 : To (M56)
 B5 (F27) W/20 : To (M57)
 B5 * (F28) L/4 : ECCS relay
 A5 * (F29) W/48 : Transmission control module
 B4 * (F30) W/88 : ECM (ECCS control module)

* : Be sure to connect and lock the connectors securely after repair work. Failure to do so may cause the ECM to have diagnostic trouble codes.
 Do not disconnect these connectors except in the case of working according to WORK FLOW of TROUBLE DIAGNOSES in EC and AT sections.

GI

MA

EM

LC

EC

FE

CL

MT

AT

FA

RA

BR

ST

RS

BT

HA

EL

IDX

Engine No. 2 Harness

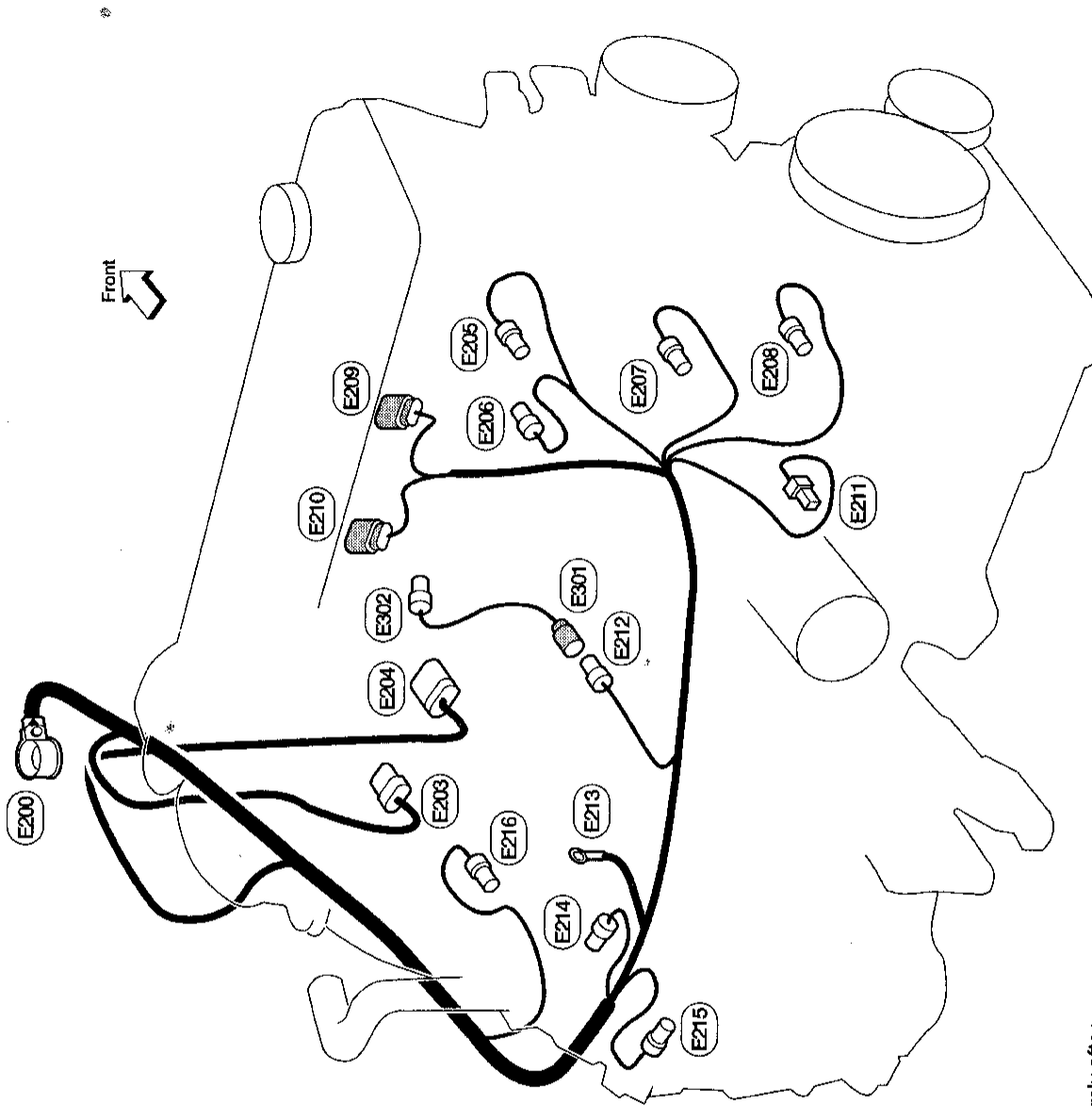

Engine Harness No. 2

- (E200) — : Battery
 - * (E201) GY/8 : To (E30)
 - * (E202) B/10 : Inhibitor switch (With A/T)
 - * (E203) GY/2 : Engine coolant temperature sensor
 - * (E204) BR/2 : IACV-AAC valve
 - (E205) PU/2 : IACV-FICD solenoid valve
 - (E206) GY/1 : Power steering oil pressure switch
 - * (E207) GY/6 : To (F22)
 - * (E210) B/8 : To (F21)
 - (E211) B/1 : Oil pressure switch
 - (E212) GY/2 : To (E30)
 - (E213) — : Starter motor
 - (E214) GY/1 : Starter motor
 - (E215) GY/2 : Vehicle speed sensor
 - * (E216) GY/4 : Neutral position switch (With M/T)
- Sub-harness**
- (E30) GY/2 : To (E212)
 - (E302) B/2 : Knock sensor

* : Be sure to connect and lock the connectors securely after repair work. Failure to do so may cause the ECM to have diagnostic trouble codes.
Do not disconnect these connectors except in the case of working according to WORK FLOW of TROUBLE DIAGNOSES in EC and AT sections.

HARNESS LAYOUT

NOTES

GI

MA

EM

LC

EC

FE

CL

MT

AT

FA

RA

BR

ST

RS

BT

HA

EL

IDX

HARNESS LAYOUT

Body Harness

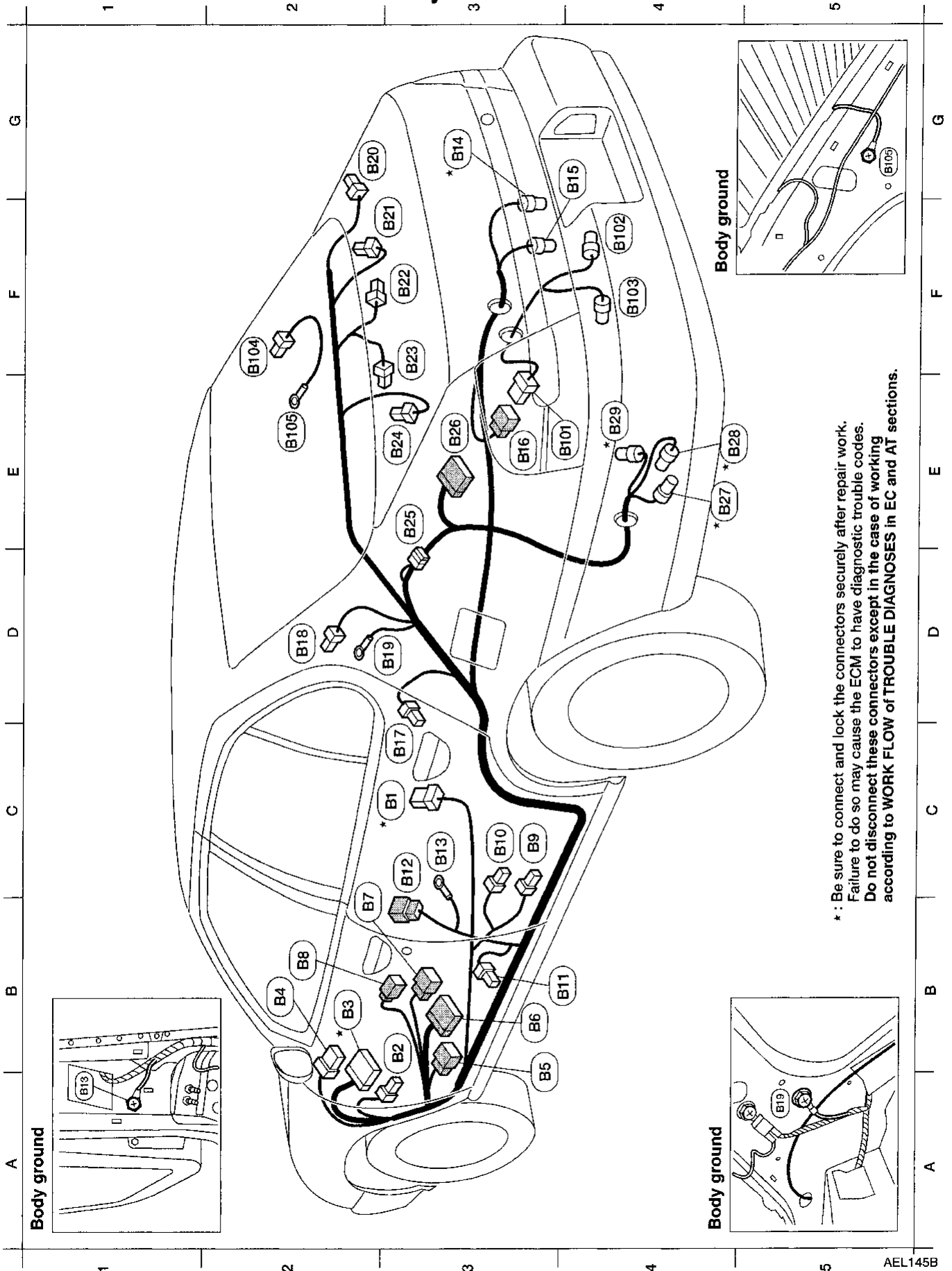

* : Be sure to connect and lock the connectors securely after repair work. Failure to do so may cause the ECM to have diagnostic trouble codes. Do not disconnect these connectors except in the case of working according to WORK FLOW of TROUBLE DIAGNOSES in EC and AT sections.

HARNES LAYOUT

Body Harness (Cont'd)

<p>C3 * (B1) W/8 : To (F25)</p> <p>B3 (B2) B/2 : Fuse block (J/B)</p> <p>B2 * (B3) W/12 : Fuse block (J/B)</p> <p>B2 (B4) BR/6 : Rear window defogger relay</p> <p>A3 (B5) W/8 : To (M5)</p> <p>B3 (B6) W/20 : To (M6)</p> <p>B2 (B7) W/6 : To (E54)</p> <p>B2 (B8) W/2 : To (E52)</p> <p>C3 (B9) W/2 : Power seat (Driver's side)</p> <p>C3 (B10) W/3 : Seat belt buckle switch</p> <p>B4 (B11) B/3 : Front door switch LH</p> <p>C3 (B12) W/8 : To (D40)</p> <p>C3 (B13) — : Body ground</p> <p>G3 * (B14) GY/4 : Fuel tank gauge unit</p> <p>G4 (B15) GY/2 : Fuel pump</p>	<p>E3 (B16) W/6 : To (B10)</p> <p>C3 (B17) BR/1 : Rear door switch LH</p> <p>D2 (B18) B/1 : Condenser</p> <p>D3 (B19) — : Body ground</p> <p>G2 (B20) BR/1 : Rear door switch RH</p> <p>F3 (B21) BR/2 : Rear speaker RH</p> <p>F3 (B22) W/2 : High-mounted stop lamp</p> <p>F3 (B23) W/2 : Trunk room lamp</p> <p>E3 (B24) BR/2 : Rear speaker LH</p> <p>E3 (B25) W/2 : Diode</p> <p>E3 (B26) W/10 : To (T4)</p> <p>E4 * (B27) B/2 : EVAP canister vent control valve</p> <p>E5 * (B28) GY/3 : EVAP control system pressure sensor</p> <p>E4 * (B29) G/2 : Vacuum cut valve bypass valve</p>	<p style="text-align: center;">Sub-harness</p> <p>E3 (B10) W/6 : To (B16)</p> <p>F4 (B10) GY/2 : Rear wheel sensor RH</p> <p>F4 (B10) BR/2 : Rear wheel sensor LH</p> <p>F2 (B10) B/1 : Rear window defogger (Ground)</p> <p>E2 (B10) — : Body ground</p>
---	--	---

* : Be sure to connect and lock the connectors securely after repair work. Failure to do so may cause the ECM to have diagnostic trouble codes.
 Do not disconnect these connectors except in the case of working according to WORK FLOW of TROUBLE DIAGNOSES in EC and AT sections.

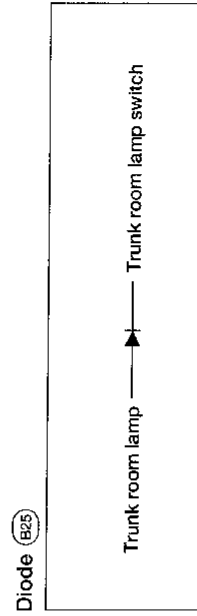

GI
 MA
 EM
 LC
 EC
 FE
 CL
 MT
 AT
 FA
 RA
 BR
 ST
 RS
 BT
 HA
EL
 DX

HARNESS LAYOUT

Tail Harness

- (T1) B/2 : Trunk room lamp switch
- (T2) W/2 : Trunk lid key cylinder switch (unlock switch)
- (T4) W/10 : To (B26)
- (T5) W/6 : Rear combination lamp LH
- (T6) — : Body ground
- (T7) BR/2 : License plate lamp LH
- (T8) BR/2 : License plate lamp RH
- (T9) — : Body ground
- (T10) W/6 : Rear combination lamp RH
- (T11) W/6 : Power antenna
- (T12) BR/2 : High-mounted stop lamp (with rear spoiler)

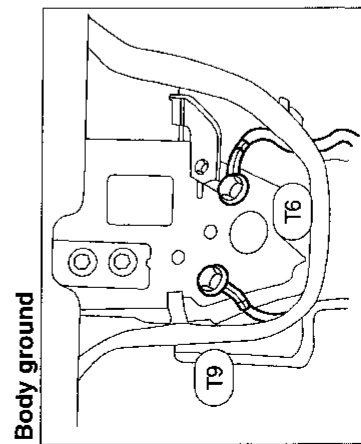
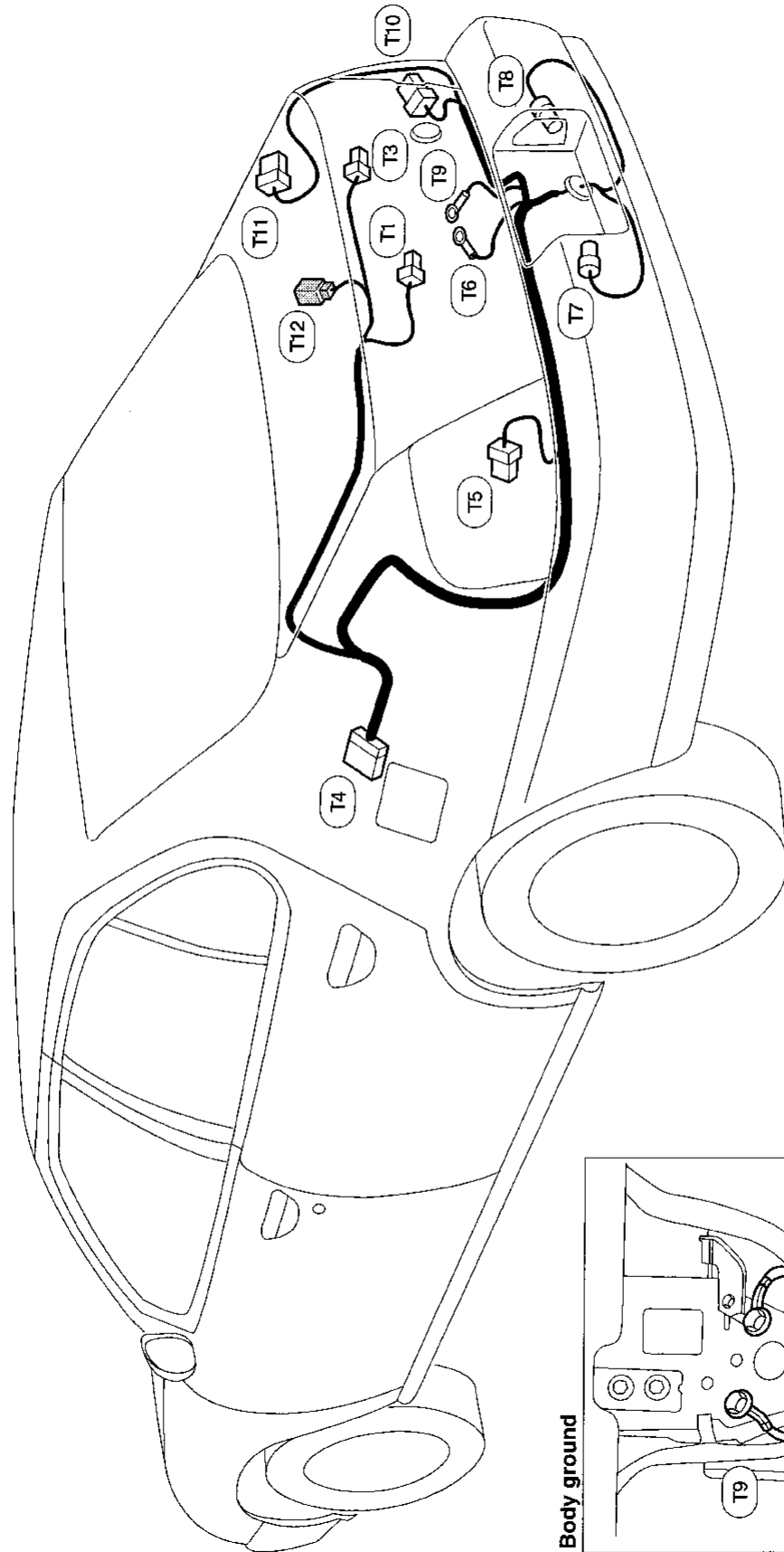

HARNESS LAYOUT

Room Lamp

- Ⓡ1 W/4 : To Ⓜ1
- Ⓡ2 B/2 : Vanity mirror illumination LH
- Ⓡ3 W/2 : Spot lamp
- Ⓡ4 B/2 : Vanity mirror illumination RH
- Ⓡ5 W/2 : Room lamp (Without sunroof)
- Ⓡ6 W/2 : Room lamp (With sunroof)

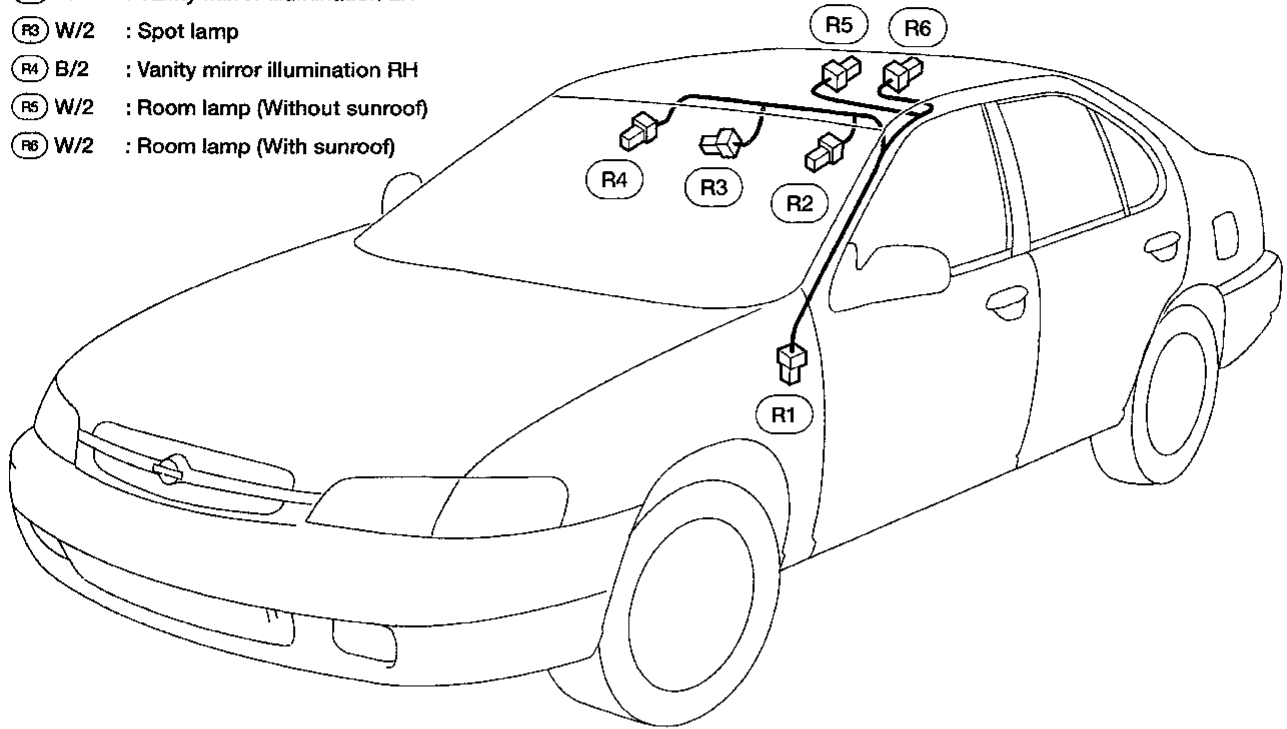

GI

MA

EM

LC

EC

FE

CL

MT

AT

FA

RA

BR

ST

RS

BT

HA

EL

IDX

HARNESS LAYOUT

Door Harness (LH side)

FRONT

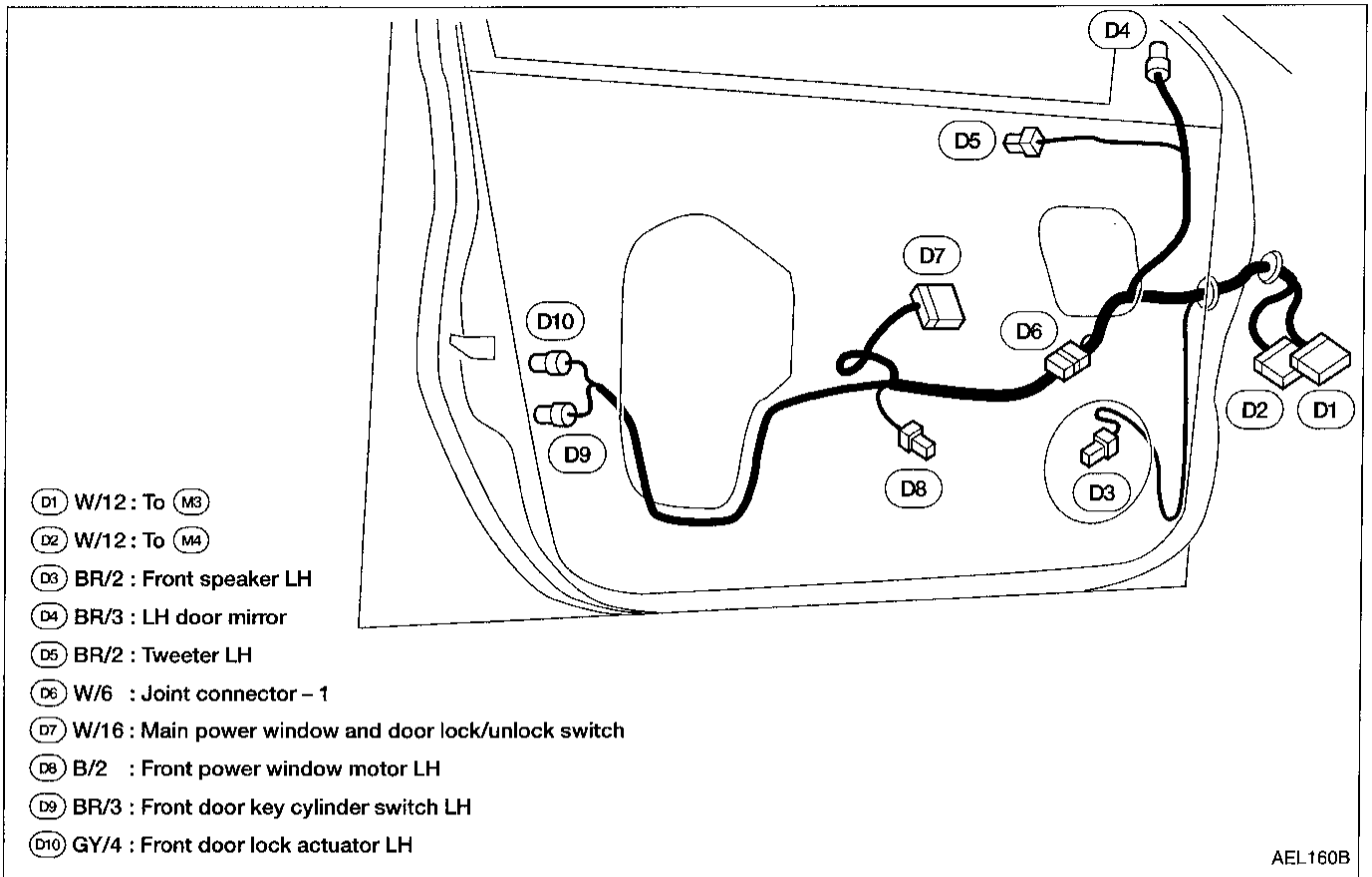

REAR

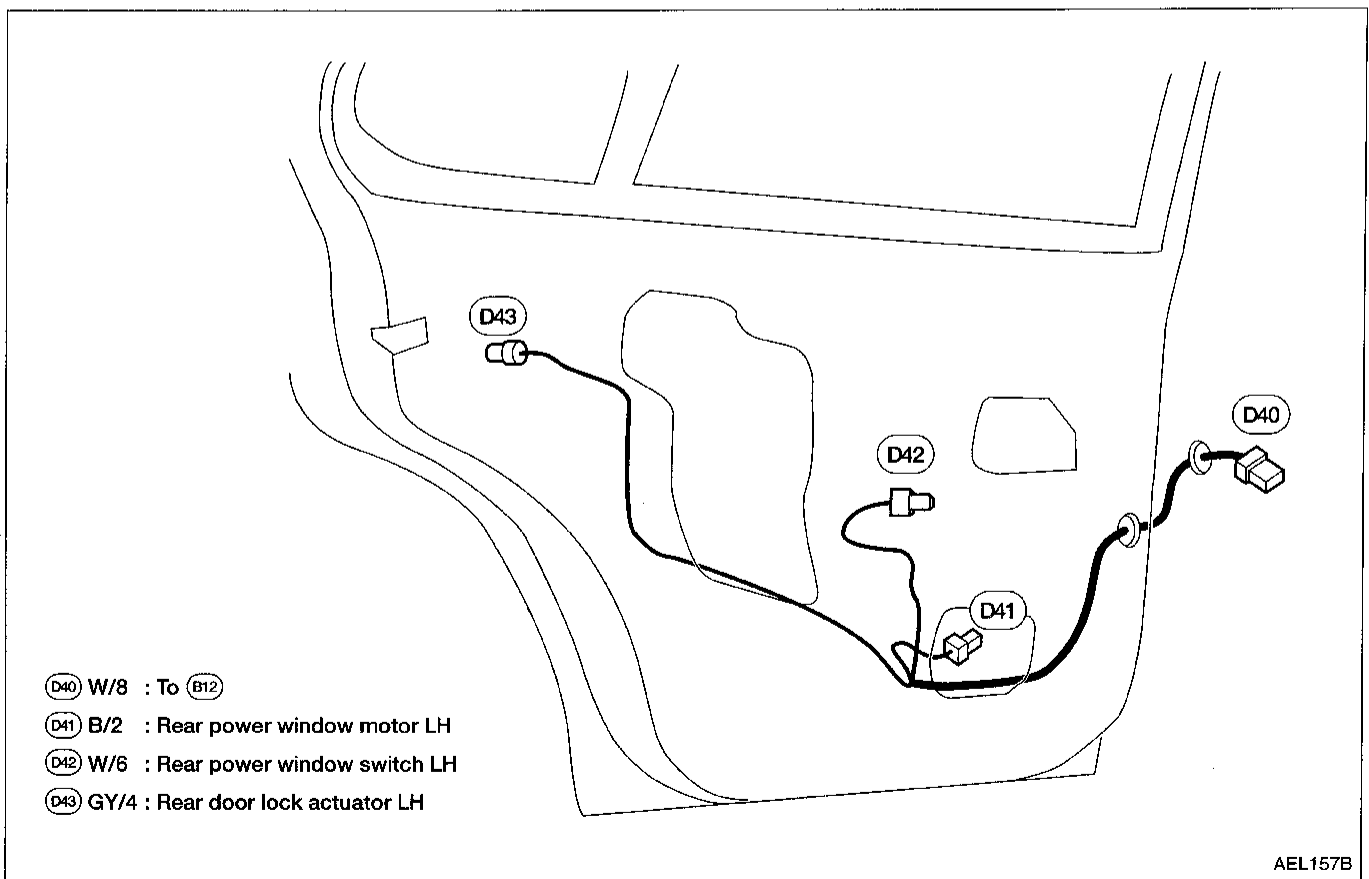

HARNESS LAYOUT

Door Harness (RH side)

FRONT

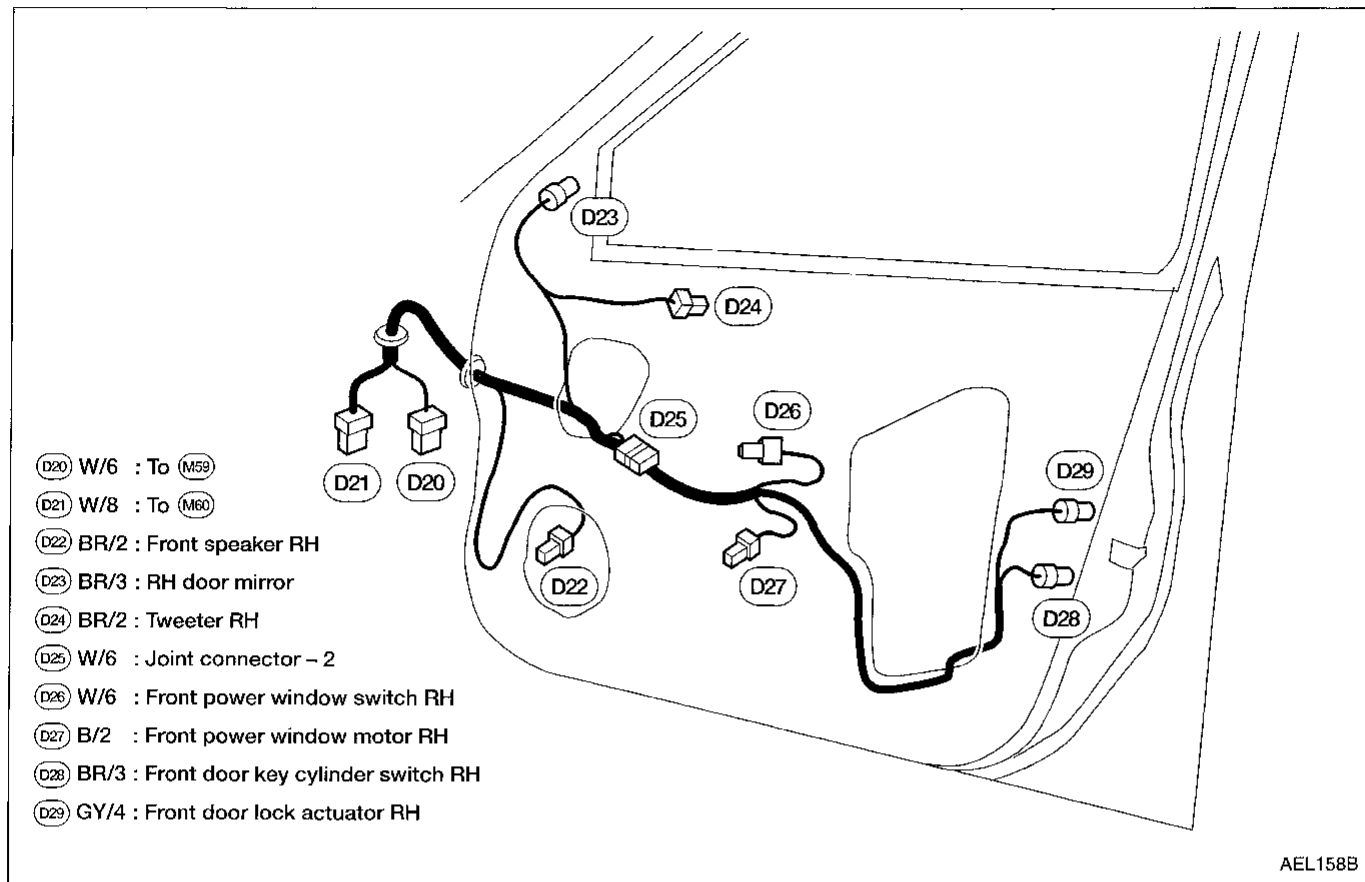

REAR

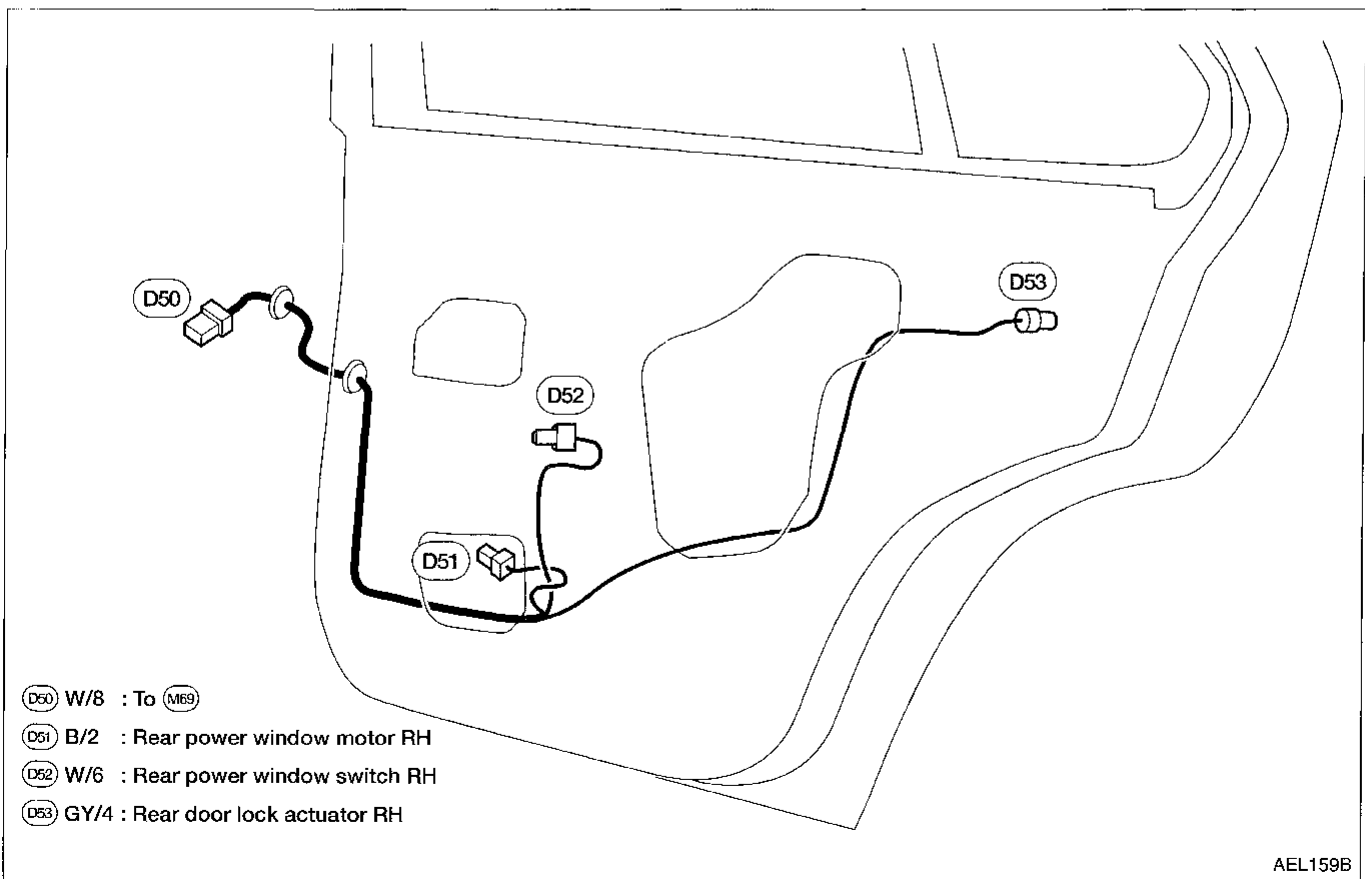

GI
MA
EM
LC
EC
FE
CL
MT
AT
FA
RA
BR
ST
RS
BT
HA
EL
IDX

HARNES LAYOUT

Air Bag Harness

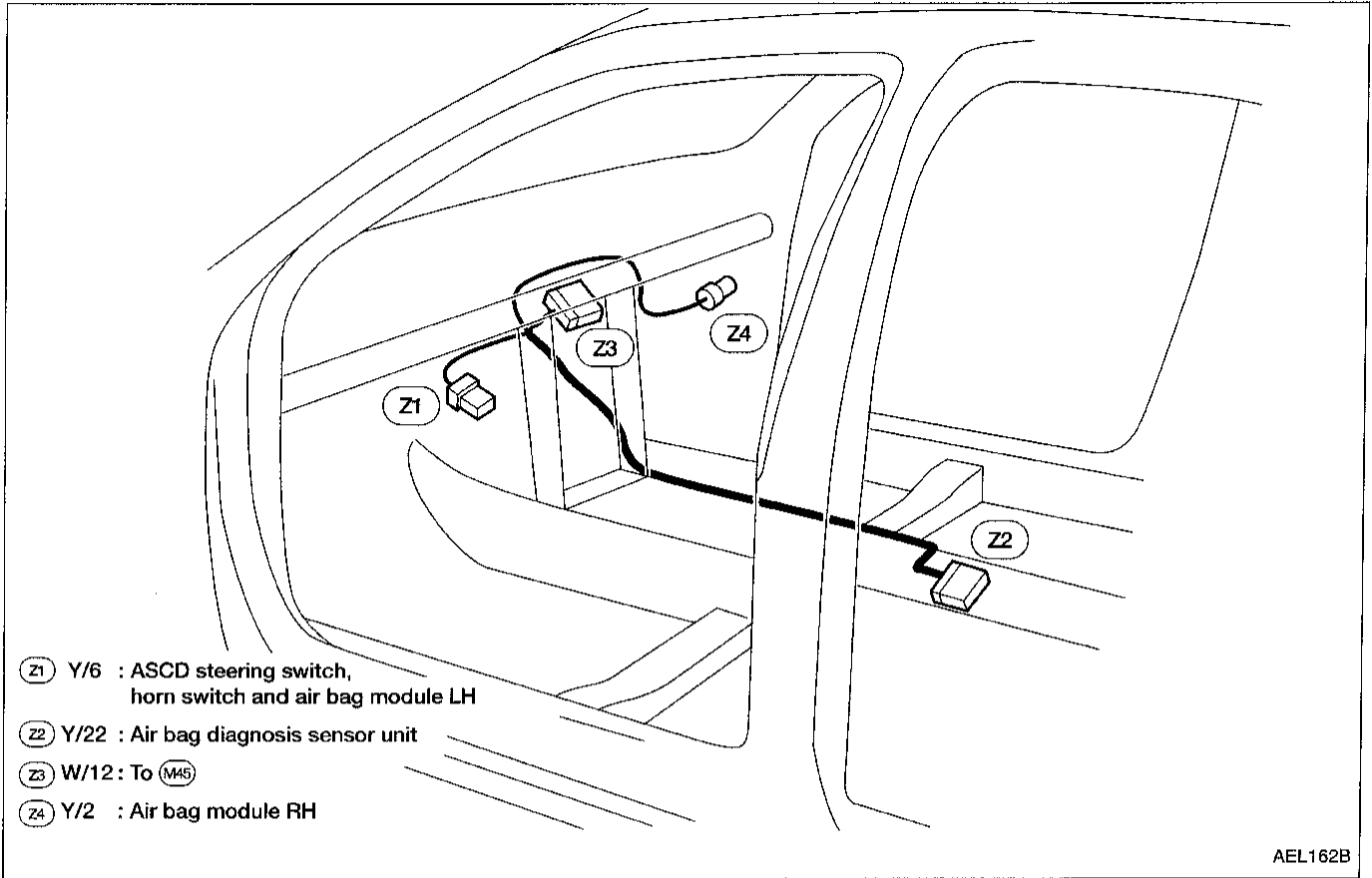

BULB SPECIFICATIONS

Headlamp

	Wattage (12 volt)	
High/low	65/55 (HB5)	GI

Exterior Lamp

		Wattage (12 volt)	
Front combination lamp	Turn/Park	27/8	EM
Front fog lamp		37.5	
Rear combination lamp	Turn signal	27	LC
	Stop/Tail	8/27	
	Back-up	18	
License plate lamp		5	EC
High mounted stop lamp		18	

Interior Lamp

	Wattage (12 volt)	
Interior lamp	8	CL
Map lamp	10	
Trunk room lamp	3.4	MT

AT

FA

RA

BR

ST

RS

BT

HA

EL

IDX

WIRING DIAGRAM CODES (CELL CODES)

Use the chart below to find out what each wiring diagram code stands for.

Code	Section	Wiring Diagram Name
1ST	AT	A/T 1st Gear Function
2ND	AT	A/T 2nd Gear Function
3RD	AT	A/T 3rd Gear Function
4TH	AT	A/T 4th Gear Function
A/C	HA	Air Conditioner
AAC/V	EC	IACV-AAC Valve
ABS	BR	Anti-Lock Brake System
AP/SEN	EC	Absolute Pressure Sensor
ASCD	EL	Automatic Speed Control Device (ASCD)
AT/C	EC	A/T Control
ATDIAG	EC	A/T Diagnosis Communication Line
AUDIO	EL	Audio
BA/FTS	AT	A/T Fluid Temperature Sensor and A/T Control Unit Power Supply
BACK/L	EL	Back-up Lamp
BYPS/V	EC	Vacuum Cut Valve Bypass Valve
CHARGE	EL	Charging System
CHIME	EL	Warning Chime
CIGAR	EL	Cigarette Lighter
CKPS	EC	Crankshaft Position Sensor (OBD)
CMPS	EC	Camshaft Position Sensor
COOL/F	EC	Cooling Fan Control
CORNER	EL	Cornering Lamp
D/LOCK	EL	Power Door Lock
DEF	EL	Rear Window Defogger
DTRL	EL	Headlamp-With Daytime Light System
ECTS	EC	Engine Coolant Temperature Sensor
EGR/TS	EC	EGR Temperature Sensor
EGRC/V	EC	EGRC-Solenoid Valve
EGRC1	EC	EGR Function
ENGSS	AT	Engine Speed Signal
F/FOG	EL	Front Fog Lamp
F/PUMP	EC	Fuel Pump
FICD	EC	IACV-FICD Solenoid Valve
FRO2	EC	Front Heated Oxygen Sensor
FRO2/H	EC	Front Heated Oxygen Sensor Heater
FTS	AT	A/T Fluid Temperature Sensor
FUEL	EC	Fuel Injection System Function
H/LAMP	EL	Headlamp
HEATER	HA	Heater System

Code	Section	Wiring Diagram Name
HORN	EL	Horn
IATS	EC	Intake Air Temperature Sensor
IGN/SG	EC	Ignition Signal
ILL	EL	Illumination
INH/SW	AT	Inhibitor Switch
INJECT	EC	Injector
INT/L	EL	Spot, Trunk Room and Vanity Mirror Lamp
KS	EC	Knock Sensor
LOAD	EC	Load Signal
LPSV	AT	Line Pressure Solenoid Valve
MAFS	EC	Mass Air Flow Sensor
MAIN	AT	Main Power Supply and Ground Circuit
MAIN	EC	Main Power Supply and Ground Circuit
METER	EL	Meter and Gauges
MIL/DL	EC	MIL and Data Link Connectors
MIRROR	EL	Door Mirror
MULTI	EL	Multi-remote Control System
NONDTC	AT	Non-detective Items
OVRCSV	AT	Over Run Clutch Solenoid Valve
P/ANT	EL	Power Antenna
PGC/V	EC	EVAP Canister Purge Volume Control Solenoid Valve
PNP/SW	EC	Neutral Position Switch
POWER	EL	Power Supply Routing
PRE/SE	EC	EVAP Control System Pressure Sensor
PST/SW	EC	Power Steering Oil Pressure Switch
ROOM/L	EL	Interior Room Lamp
RRO2	EC	Rear Heated Oxygen Sensor
RRO2/H	EC	Rear Heated Oxygen Sensor Heater
S/SIG	EC	Start Signal
SEAT	EL	Power Seat
SHIFT	AT	A/T Shift Lock System
SROOF	EL	Sunroof
SRS	RS	Supplemental Restraint System
SSV/A	AT	Shift Solenoid Valve A
SSV/B	AT	Shift Solenoid Valve B
START	EL	Starting System
STOP/L	EL	Stop Lamp

WIRING DIAGRAM CODES (CELL CODES)

Code	Section	Wiring Diagram Name
SW/V	EC	MAP/BARO Switch Solenoid Valve
TAIL/L	EL	Parking, License, and Tail Lamps
TCCSIG	AT	A/T TCC Signal (Lock Up)
TCV	AT	Torque Convertor Clutch Solenoid Valve
TFTS	EC	Tank Fuel Temperature Sensor
THEFT	EL	Theft Warning System
TP/SW	EC	Throttle Position Switch
TPS	AT	Throttle Position Sensor
TPS	EC	Throttle Position Sensor
TURN	EL	Turn Signal and Hazard Warning Lamps

Code	Section	Wiring Diagram Name
VENT/V	EC	EVAP Canister Vent Control Valve
VSS	EC	Vehicle Speed Sensor
VSSA/T	AT	Vehicle Speed Sensor A/T (Revolution Sensor)
VSSMTR	AT	Vehicle Speed Sensor MTR
WARN	EL	Warning Lamps
WINDOW	EL	Power Window
WIPER	EL	Front Wiper and Washer

GI

MA

EM

LC

EC

FE

CL

MT

AT

FA

RA

BR

ST

RS

BT

HA

EL

IDX