

SECTION AT

CONTENTS

DIAGNOSTIC TROUBLE CODE INDEX.....	2	TROUBLE DIAGNOSIS — General Description ...	67
Alphabetical & P No. Index for DTC.....	2	Symptom Chart.....	67
PRECAUTIONS AND PREPARATION.....	3	TCM Terminals and Reference Value.....	70
Supplemental Restraint System (SRS) "AIR BAG".....	3	TROUBLE DIAGNOSIS FOR POWER SUPPLY.....	74
Precautions for On Board Diagnostic (OBD) System of A/T and Engine.....	3	Main Power Supply and Ground Circuit.....	74
Precautions.....	4	TROUBLE DIAGNOSIS FOR DTC P0705.....	76
Service Notice or Precautions.....	5	Inhibitor Switch.....	76
Special Service Tools.....	7	TROUBLE DIAGNOSIS FOR DTC P0710.....	81
Commercial Service Tools.....	10	A/T Fluid Temperature Sensor.....	81
OVERALL SYSTEM.....	11	TROUBLE DIAGNOSIS FOR DTC P0720.....	86
A/T Electrical Parts Location.....	11	Vehicle Speed Sensor-A/T (Revolution sensor) ...	86
Circuit Diagram for Quick Pinpoint Check.....	12	TROUBLE DIAGNOSIS FOR DTC P0725.....	90
Cross-sectional View.....	13	Engine Speed Signal.....	90
Hydraulic Control Circuit.....	14	TROUBLE DIAGNOSIS FOR DTC P0731.....	94
Shift Mechanism.....	15	A/T 1st Gear Function.....	94
Control System.....	24	TROUBLE DIAGNOSIS FOR DTC P0732.....	101
Control Mechanism.....	26	A/T 2nd Gear Function.....	101
Control Valve.....	31	TROUBLE DIAGNOSIS FOR DTC P0733.....	107
ON BOARD DIAGNOSTIC SYSTEM		A/T 3rd Gear Function.....	107
DESCRIPTION.....	32	TROUBLE DIAGNOSIS FOR DTC P0734.....	113
Introduction.....	32	A/T 4th Gear Function.....	113
OBD-II Function for A/T System.....	32	TROUBLE DIAGNOSIS FOR DTC P0740.....	122
One or Two Trip Detection Logic of OBD-II.....	32	Torque Converter Clutch Solenoid Valve.....	122
OBD-II Diagnostic Trouble Code (DTC).....	32	TROUBLE DIAGNOSIS FOR DTC P0744.....	127
Malfunction Indicator Lamp (MIL).....	36	A/T TCC S/V Function (Lock-up).....	127
CONSULT.....	36	TROUBLE DIAGNOSIS FOR DTC P0745.....	135
Diagnostic Procedure Without CONSULT.....	43	Line Pressure Solenoid Valve.....	135
TROUBLE DIAGNOSIS — Introduction.....	47	TROUBLE DIAGNOSIS FOR DTC P0750.....	140
Introduction.....	47	Shift Solenoid Valve A.....	140
Diagnostic Worksheet.....	48	TROUBLE DIAGNOSIS FOR DTC P0755.....	145
Work Flow.....	51	Shift Solenoid Valve B.....	145
TROUBLE DIAGNOSIS — Basic Inspection.....	52	TROUBLE DIAGNOSIS FOR DTC P1705.....	150
A/T Fluid Check.....	52	Throttle Position Sensor.....	150
Stall Test.....	52	TROUBLE DIAGNOSIS FOR DTC P1760.....	157
Pressure Test.....	55	Overrun Clutch Solenoid Valve.....	157
Road Test.....	56	TROUBLE DIAGNOSIS FOR BATT/FLUID TEMP SEN.....	162

CONTENTS (Cont'd.)

A/T Fluid Temperature Sensor Circuit and TCM Power Source	162	Shift Lock System Electrical Parts Location.....	197	GI
TROUBLE DIAGNOSIS FOR VHCL SPEED		Wiring Diagram — SHIFT —	198	
SEN-MTR	167	Diagnostic Procedure.....	199	
Vehicle Speed Sensor-MTR.....	167	Key Interlock Cable.....	201	MA
TROUBLE DIAGNOSES FOR SYMPTOMS	171	Component Check	202	
Non-detectable Items.....	171	ON-VEHICLE SERVICE	204	
1. O/D OFF Indicator Lamp Does Not Come On	174	Control Valve Assembly and Accumulator.....	204	EM
2. Engine Cannot Be Started In “P” and “N” Position	175	Revolution Sensor Replacement	205	LC
3. In “P” Position, Vehicle Moves Forward or Backward When Pushed	175	Inhibitor Switch Adjustment.....	205	LC
4. In “N” Position, Vehicle Moves	176	Control Cable Adjustment.....	206	
5. Large Shock. “N” → “R” Position	177	Differential Side Oil Seal Replacement	206	
6. Vehicle Does Not Creep Backward In “R” Position	178	REMOVAL AND INSTALLATION	207	EC
7. Vehicle Does Not Creep Forward In “D”, “2” or “1” Position	179	Removal	207	
8. Vehicle Cannot Be Started From D ₁	180	Installation.....	208	
9. A/T Does Not Shift: D ₁ → D ₂ or Does Not Kickdown: D ₄ → D ₂	181	MAJOR OVERHAUL	210	FE
10. A/T Does Not Shift: D ₂ → D ₃	182	Locations of Adjusting Shims, Needle Bearings, Thrust Washers and Snap Rings	213	
11. A/T Does Not Shift: D ₃ → D ₄	183	Oil Channel	214	CL
12. A/T Does Not Perform Lock-up	184	DISASSEMBLY	215	
13. A/T Does Not Hold Lock-up Condition	185	REPAIR FOR COMPONENT PARTS	229	MT
14. Lock-up Is Not Released.....	185	Manual Shaft.....	229	
15. Engine Speed Does Not Return To Idle (Light Braking D ₄ → D ₃)	186	Oil Pump	231	
16. Vehicle Does Not Start From D ₁	187	Control Valve Assembly	235	AT
17. A/T Does Not Shift: D ₄ → D ₃ , When Overdrive Control Switch “ON” → “OFF”	187	Control Valve Upper Body	243	
18. A/T Does Not Shift: D ₃ → 2 ₂ , When Selector Lever “D” → “2” Position.....	188	Control Valve Lower Body	247	FA
19. A/T Does Not Shift: 2 ₂ → 1 ₁ , When Selector Lever “2” → “1” Position	188	Reverse Clutch	249	
20. Vehicle Does Not Decelerate By Engine Brake.....	189	High Clutch	252	
21. TCM Self-diagnosis Does Not Activate (Inhibitor, Overdrive Control and Throttle Position Switch Circuit Checks).....	189	Forward Clutch and Overrun Clutch.....	256	RA
TROUBLE DIAGNOSES — A/T Shift Lock		Low & Reverse Brake.....	262	
System	197	Rear Internal Gear, Forward Clutch Hub and Overrun Clutch Hub	264	BR
Description	197	Output Shaft, Idler Gear, Reduction Pinion Gear and Bearing Retainer.....	268	
		Band Servo Piston Assembly	273	ST
		Final Drive.....	278	
		ASSEMBLY	282	RS
		Assembly 1	282	
		Adjustment 1	282	
		Assembly 2	287	BT
		Adjustment 2.....	293	
		Assembly 3	295	
		SERVICE DATA AND SPECIFICATIONS (SDS) ...	301	HA
		General Specifications	301	
		Specifications and Adjustments	301	EL

When you read wiring diagrams:

- Read GI section, “HOW TO READ WIRING DIAGRAMS”.
- See EL section, “POWER SUPPLY ROUTING” for power distribution circuit.

When you perform trouble diagnoses, read GI section, “HOW TO FOLLOW FLOW CHART IN TROUBLE DIAGNOSES” and “HOW TO PERFORM EFFICIENT DIAGNOSIS FOR AN ELECTRICAL INCIDENT”.

DIAGNOSTIC TROUBLE CODE INDEX

Alphabetical & P No. Index for DTC

ALPHABETICAL INDEX FOR DTC

Items (CONSULT screen terms)	DTC		Reference page
	ECM*1	CONSULT GST*2	
A/T 1ST GR FNCTN	1103	P0731	AT-94
A/T 2ND GR FNCTN	1104	P0732	AT-101
A/T 3RD GR FNCTN	1105	P0733	AT-107
A/T 4TH GR FNCTN	1106	P0734	AT-113
A/T TCC S/V FNCTN	1107	P0744	AT-127
ENGINE SPEED SIG*4	1207	P0725	AT-90
ATF TEMP SEN/CIRC	1208	P0710	AT-81
INHIBITOR SW/CIRC	1101	P0705	AT-76
L/PRESS SOL/CIRC	1205	P0745	AT-135
O/R CLTCH SOL/CIRC	1203	P1760	AT-157
SFT SOL A/CIRC*3	1108	P0750	AT-140
SFT SOL B/CIRC*3	1201	P0755	AT-145
TP SEN/CIRC A/T*3	1206	P1705	AT-150
TCC SOLENOID/CIRC	1204	P0740	AT-122
VEH SPD SEN/CIR AT*4	1102	P0720	AT-86

P NO. INDEX FOR DTC

DTC		Items (CONSULT screen terms)	Reference page
CONSULT GST*2	ECM*1		
P0705	1101	INHIBITOR SW/CIRC	AT-76
P0710	1208	ATF TEMP SEN/CIRC	AT-81
P0720	1102	VEH SPD SEN/CIR AT*4	AT-86
P0725	1207	ENGINE SPEED SIG*4	AT-90
P0731	1103	A/T 1ST GR FNCTN	AT-94
P0732	1104	A/T 2ND GR FNCTN	AT-101
P0733	1105	A/T 3RD GR FNCTN	AT-107
P0734	1106	A/T 4TH GR FNCTN	AT-113
P0740	1204	TCC SOLENOID/CIRC	AT-122
P0744	1107	A/T TCC S/V FNCTN	AT-127
P0745	1205	L/PRESS SOL/CIRC	AT-135
P0750	1108	SFT SOL A/CIRC*3	AT-140
P0755	1201	SFT SOL B/CIRC*3	AT-145
P1705	1206	TP SEN/CIRC A/T*3	AT-150
P1760	1203	O/R CLTCH SOL/CIRC	AT-157

*1: In Diagnostic Test Mode II (Self-diagnostic results), these numbers are controlled by NISSAN.

*2: These numbers are prescribed by SAE J2012.

*3: When the fail-safe operation occurs, the MIL illuminates.

*4: The MIL illuminates after TCM enters the fail-safe mode in two consecutive trips, if both the "Revolution sensor" and the "Engine speed signal" meet the fail-safe condition at the same time.

Supplemental Restraint System (SRS) "AIR BAG"

The Supplemental Restraint System "Air Bag", used along with a seat belt, helps to reduce the risk or severity of injury to the driver and front passenger in a frontal collision. The Supplemental Restraint System consists of air bag modules (located in the center of the steering wheel and in the instrument panel on the passenger side), a diagnosis sensor unit, warning lamp, wiring harness and spiral cable. Information necessary to service the system safely is included in the **RS section** of this Service Manual.

WARNING:

- To avoid rendering the SRS inoperative, which could increase the risk of personal injury or death in the event of a collision which would result in air bag inflation, all maintenance must be performed by an authorized NISSAN dealer.
- Improper maintenance, including incorrect removal and installation of the SRS, can lead to personal injury caused by unintentional activation of the system.
- Do not use electrical test equipment on any circuit related to the SRS unless instructed to in this Service Manual. SRS wiring harnesses are covered with yellow insulation just before the harness connectors for easy identification.

Precautions for On Board Diagnostic (OBD) System of A/T and Engine

The ECM (ECCS control module) has an on board diagnostic system. It will light up the malfunction indicator lamp (MIL) to warn the driver of a malfunction causing emission deterioration.

CAUTION:

- Be sure to turn the ignition switch OFF and disconnect the negative battery terminal before any repair or inspection work. The open/short circuit of related switches, sensors, solenoid valves, etc. will cause the MIL to light up.
- Be sure to connect and lock the connectors securely after work. A loose (unlocked) connector will cause the MIL to light up due to an open circuit. (Be sure the connector is free from water, grease, dirt, bent terminals, etc.)
- Be sure to route and secure the harnesses properly after work. Interference of the harness with a bracket, etc. may cause the MIL to light up due to a short circuit.
- Be sure to connect rubber tubes properly after work. A misconnected or disconnected rubber tube may cause the MIL to light up due to a malfunction of the EGR system or fuel injection system, etc.
- Be sure to erase the unnecessary malfunction information (repairs completed) from the TCM or ECM before returning the vehicle to the customer.

PRECAUTIONS AND PREPARATION

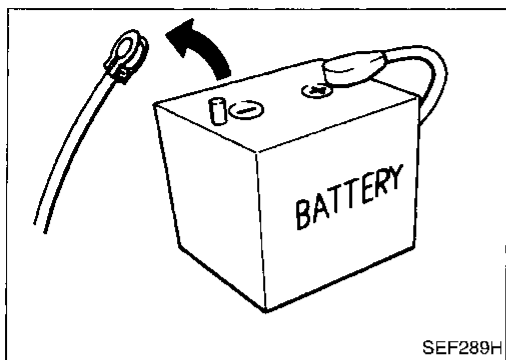

Precautions

- Before connecting or disconnecting the TCM harness connector, turn ignition switch OFF and disconnect negative battery terminal. Failure to do so may damage the TCM. Because battery voltage is applied to TCM even if ignition switch is turned off.

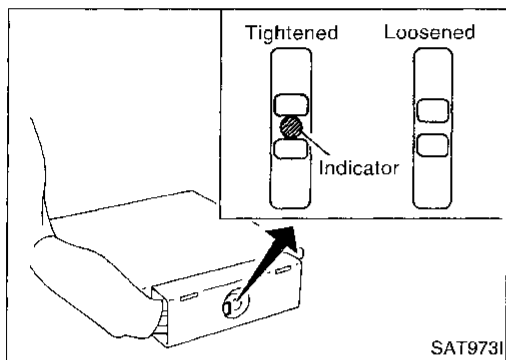

- When connecting TCM harness connector, tighten securing bolt until the orange indicator appears.
⚙️: 3.0 - 5.0 N·m (0.3 - 0.5 kg-m, 26 - 43 in-lb)

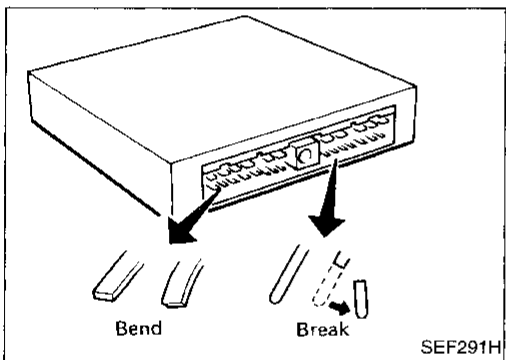

- When connecting or disconnecting pin connectors into or from TCM, take care not to damage pin terminals (bend or break).
Make sure that there are not any bends or breaks on TCM pin terminal, when connecting pin connectors.

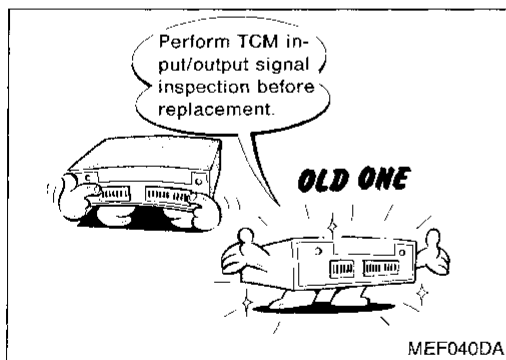

- Before replacing TCM, perform TCM input/output signal inspection and make sure whether TCM functions properly or not. (See page AT-70.)

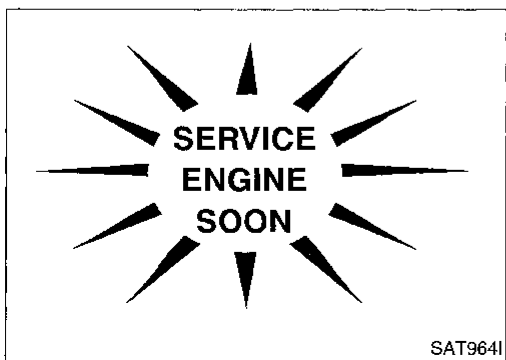

- After performing each TROUBLE DIAGNOSIS, perform "DTC (Diagnostic Trouble Code) CONFIRMATION PROCEDURE".
The DTC should not be displayed in the "DTC CONFIRMATION PROCEDURE" if the repair is completed.

PRECAUTIONS AND PREPARATION

Precautions (Cont'd)

- Before proceeding with disassembly, thoroughly clean the outside of the transaxle. It is important to prevent the internal parts from becoming contaminated by dirt or other foreign matter.
- Disassembly should be done in a clean work area.
- Use lint-free cloth or towels for wiping parts clean. Common shop rags can leave fibers that could interfere with the operation of the transaxle.
- Place disassembled parts in order for easier and proper assembly.
- All parts should be carefully cleaned with a general purpose, non-flammable solvent before inspection or reassembly.
- Gaskets, seals and O-rings should be replaced any time the transaxle is disassembled.
- It is very important to perform functional tests whenever they are indicated.
- The valve body contains precision parts and requires extreme care when parts are removed and serviced. Place disassembled valve body parts in order for easier and proper assembly. Care will also prevent springs and small parts from becoming scattered or lost.
- Properly installed valves, sleeves, plugs, etc. will slide along bores in valve body under their own weight.
- Before assembly, apply a coat of recommended ATF to all parts. Apply petroleum jelly to protect O-rings and seals, or hold bearings and washers in place during assembly. Do not use grease.
- Extreme care should be taken to avoid damage to O-rings, seals and gaskets when assembling.
- Replace ATF cooler if excessive foreign material is found in oil pan or clogging strainer. Refer to "ATF COOLER SERVICE" (Refer to AT-6).
- After overhaul, refill the transmission with new ATF.
- When the A/T drain plug is removed, only some of the fluid is drained. Old A/T fluid will remain in torque converter and ATF cooling system.

Always follow the procedures under "Changing A/T Fluid" in the MA section when changing A/T fluid.

Service Notice or Precautions

FAIL-SAFE

The TCM has an electronic Fail-Safe (limp home mode). This allows the vehicle to be driven even if a major electrical input/output device circuit is damaged.

Under Fail-Safe, the vehicle always runs in third gear, even with a shift lever position of "1", "2" or "D". The customer may complain of sluggish or poor acceleration.

When the ignition key is turned "ON" following Fail-Safe operation, O/D OFF indicator lamp blinks for about 8 seconds. (For "TCM SELF-DIAGNOSTIC PROCEDURE (No Tools)", refer to AT-43.)

Fail-Safe may occur without electrical circuit damage if the vehicle is driven under extreme conditions (such as excessive wheel spin followed by sudden braking). To recover normal shift pattern, turn the ignition key "OFF" for 5 seconds, then "ON".

The blinking of the O/D OFF indicator lamp for about 8 seconds will appear only once and be cleared. The customer may resume normal driving conditions.

Always follow the "WORK FLOW" (Refer to AT-51).

The SELF-DIAGNOSIS results will be as follows:

The first SELF-DIAGNOSIS will indicate damage to the vehicle speed sensor or the revolution sensor.

During the next SELF-DIAGNOSIS, performed after checking the sensor, no damages will be indicated.

TORQUE CONVERTER SERVICE

The torque converter should be replaced under any of the following conditions:

- External leaks in the hub weld area.
- Converter hub is scored or damaged.
- Converter pilot is broken, damaged or fits poorly into crankshaft.
- Steel particles are found after flushing the cooler and cooler lines.
- Pump is damaged or steel particles are found in the converter.
- Vehicle has TCC shudder and/or no TCC apply. Replace only after all hydraulic and electrical diagnoses have been made. (Converter clutch material may be glazed.)
- Converter is contaminated with engine coolant containing antifreeze.
- Internal failure of stator roller clutch.
- Heavy clutch debris due to overheating (blue converter).

PRECAUTIONS AND PREPARATION

Service Notice or Precautions (Cont'd)

- Steel particles or clutch lining material found in fluid filter or on magnet when no internal parts in unit are worn or damaged — indicates that lining material came from converter.

The torque converter should not be replaced if:

- The oil has an odor, is discolored, and there is no evidence of metal or clutch facing particles.
- The threads in one or more of the converter bolt holes are damaged.
- Transaxle failure did not display evidence of damaged or worn internal parts, steel particles or clutch plate lining material in unit and inside the fluid filter.
- Vehicle has been exposed to high mileage (only). The exception may be where the torque converter clutch dampener plate lining has seen excess wear by vehicles operated in heavy and/or constant traffic, such as taxi, delivery or police use.

ATF COOLER SERVICE

Replace ATF cooler if excessive foreign material is found in oil pan or clogging strainer.

Replace radiator lower tank (which includes ATF cooler) with a new one and flush cooler line using cleaning solvent and compressed air.

OBD-II SELF-DIAGNOSIS

- A/T self-diagnosis is performed by the TCM in combination with the ECM. The results can be read through the blinking pattern of the O/D OFF indicator or the malfunction indicator lamp (MIL). Refer to the table on AT-37 for the indicator used to display each self-diagnostic result.
- The self-diagnostic results indicated by the MIL are automatically stored in both the ECM and TCM memories.

Always perform the procedure “HOW TO ERASE DTC” on AT-34 to complete the repair and avoid unnecessary blinking of the MIL.



- The following self-diagnostic items can be detected using ECM self-diagnostic results mode* only when the O/D OFF indicator lamp does not indicate any malfunctions.
 - Inhibitor switch
 - A/T 1st, 2nd, 3rd, or 4th gear function
 - A/T TCC S/V function (lock-up).

*: For details of OBD-II, refer to EC section (“ON BOARD DIAGNOSTIC SYSTEM DESCRIPTION”).

PRECAUTIONS AND PREPARATION

Special Service Tools

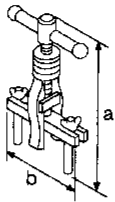
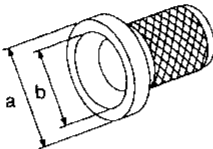
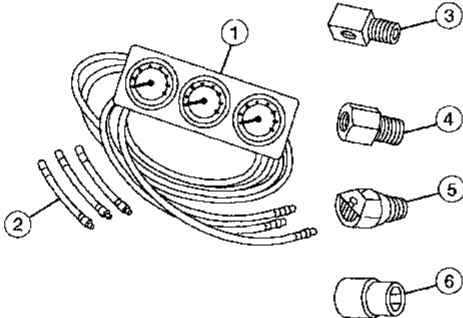
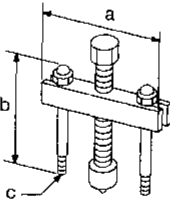
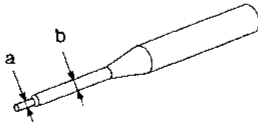
The actual shapes of Kent-Moore tools may differ from those of special service tools illustrated here.

Tool number (Kent-Moore No.) Tool name	Description	
KV381054S0 (J34286) Puller	 <p>NT414</p> <ul style="list-style-type: none"> ● Removing differential side oil seals ● Removing differential side bearing outer race ● Removing idler gear bearing outer race <p>a: 250 mm (9.84 in) b: 160 mm (6.30 in)</p>	GI MA EM LC
ST33400001 (J26082) Drift	 <p>NT086</p> <p>Installing differential side oil seal (RH side) Installing oil seal on oil pump housing</p> <p>a: 60 mm (2.36 in) dia. b: 47 mm (1.85 in) dia.</p>	EC FE
(J34301-C) Oil pressure gauge set ① (J34301-1) Oil pressure gauge ② (J34301-2) Hoses ③ (J34298) Adapter ④ (J34282-2) Adapter ⑤ (790-301-1230-A) 60° Adapter ⑥ (J34301-15) Square socket	<p>Measuring line pressure</p>  <p>AAT896</p>	CL MT AT FA RA BR
ST27180001 (J25726-A) Puller	 <p>NT424</p> <p>Removing idler gear</p> <p>a: 100 mm (3.94 in) b: 110 mm (4.33 in) c: M8 x 1.25P</p>	ST RS BT
ST23540000 (J25689-A) Pin punch	 <p>NT442</p> <p>Removing and installing parking rod plate and manual plate pins</p> <p>a: 2.3 mm (0.091 in) dia. b: 4 mm (0.16 in) dia.</p>	HA
ST25710000 (J25689-A) Pin punch	 <p>NT410</p> <p>Aligning groove of manual shaft and hole of transmission case</p> <p>a: 2 mm (0.08 in) dia.</p>	EL IDX

PRECAUTIONS AND PREPARATION

Special Service Tools (Cont'd)

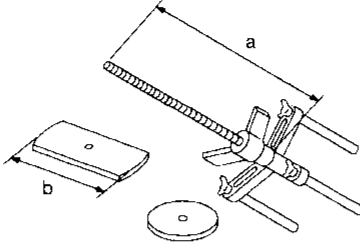
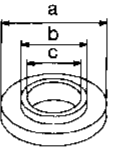
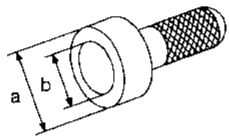
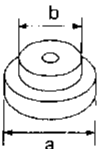
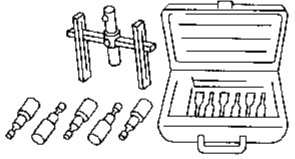
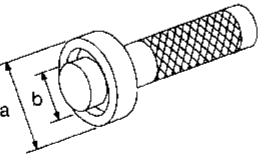
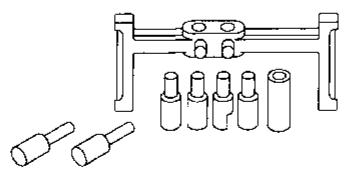
<p>KV32101000 (J25689-A) Pin punch</p>	 <p>NT410</p>	<p>Installing manual shaft retaining pin</p> <p>a: 4 mm (0.16 in) dia.</p>
<p>KV31102400 (J34285 and J34285-87) Clutch spring compressor</p>	 <p>NT423</p>	<ul style="list-style-type: none"> ● Removing and installing clutch return springs ● Installing low and reverse brake piston <p>a: 320 mm (12.60 in) b: 174 mm (6.85 in)</p>
<p>KV40100630 (J26092) Drift</p>	 <p>NT107</p>	<ul style="list-style-type: none"> ● Installing reduction gear bearing inner race ● Installing idler gear bearing inner race <p>a: 67.5 mm (2.657 in) dia. b: 44 mm (1.73 in) dia. c: 38.5 mm (1.516 in) dia.</p>
<p>ST30720000 (J25405 and J34331) Bearing installer</p>	 <p>NT115</p>	<ul style="list-style-type: none"> ● Installing idler gear bearing outer race <p>a: 77 mm (3.03 in) dia. b: 55.5 mm (2.185 in) dia.</p>
<p>ST35321000 (—) Drift</p>	 <p>NT073</p>	<ul style="list-style-type: none"> ● Installing output shaft bearing <p>a: 49 mm (1.93 in) dia. b: 41 mm (1.61 in) dia.</p>
<p>(J34291-A) Shim setting gauge set</p>	 <p>NT101</p>	<ul style="list-style-type: none"> ● Selecting oil pump cover bearing race and oil pump thrust washer ● Selecting side gear thrust washer
<p>ST33230000 (J25805-01) Drift</p>	 <p>NT084</p>	<ul style="list-style-type: none"> ● Installing differential side bearing <p>a: 51 mm (2.01 in) dia. b: 28.5 mm (1.122 in) dia.</p>
<p>(J34290) Shim selecting tool set</p>	 <p>NT080</p>	<p>Selecting differential side bearing adjusting shim</p>

PRECAUTIONS AND PREPARATION

Special Service Tools (Cont'd)

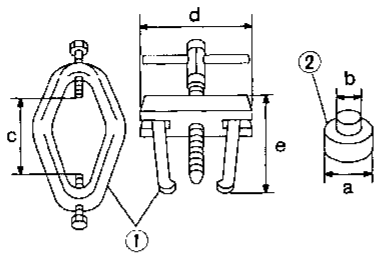
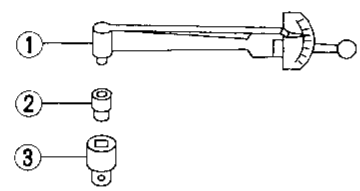
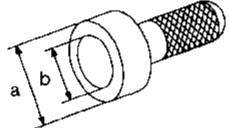
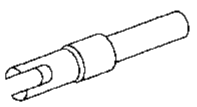
<p>ST3306S001 (J22888-D) Differential side bearing puller set</p> <p>① ST33051001 (J22888-D) Puller</p> <p>② ST33061000 (J8107-2) Adapter</p>	 <p>NT413</p>	<p>Removing differential side bearing inner race</p> <p>a: 38 mm (1.50 in) dia. b: 28.5 mm (1.122 in) dia. c: 130 mm (5.12 in) d: 135 mm (5.31 in) e: 100 mm (3.94 in)</p>	<p>GI MA EM LC</p>
<p>ST3127S000 (J25765-A) Preload gauge</p> <p>① GG91030000 (J25765-A) Torque wrench</p> <p>② HT62940000 () Socket adapter</p> <p>③ HT62900000 () Socket adapter</p>	 <p>NT124</p>	<p>Checking differential side bearing preload</p>	<p>EC FE CL MT</p>
<p>ST35271000 (J26091) Drift</p>	 <p>NT115</p>	<p>Installing idler gear</p> <p>a: 72 mm (2.83 in) dia. b: 63 mm (2.48 in) dia.</p>	<p>AT FA</p>
<p>(J39713) Preload adapter</p>	 <p>NT087</p>	<ul style="list-style-type: none"> ● Selecting differential side bearing adjusting shim ● Checking differential side bearing preload 	<p>RA BR</p>

ST
RS
BT
HA
EL
IDX

PRECAUTIONS AND PREPARATION

Commercial Service Tools

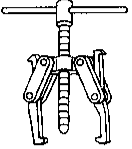
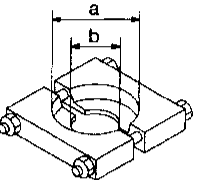
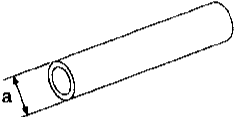
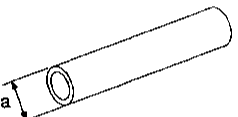
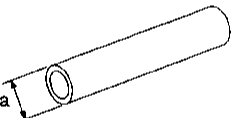
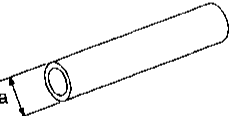
Tool name	Description
Puller	 <ul style="list-style-type: none"> ● Removing idler gear bearing inner race ● Removing and installing band servo piston snap ring <p>NT077</p>
Puller	 <p>Removing reduction gear bearing inner race</p> <p>a: 60 mm (2.36 in) dia. b: 35 mm (1.38 in) dia.</p> <p>NT411</p>
Drift	 <p>Installing differential side oil seal (Left side)</p> <p>a: 90 mm (3.54 in) dia.</p> <p>NT083</p>
Drift	 <p>Installing needle bearing on bearing retainer</p> <p>a: 36 mm (1.42 in) dia.</p> <p>NT083</p>
Drift	 <p>Removing needle bearing from bearing retainer</p> <p>a: 33.5 mm (1.319 in) dia.</p> <p>NT083</p>
Drift	 <p>Installing differential side bearing outer race</p> <p>a: 75 mm (2.95 in) dia.</p> <p>NT083</p>

OVERALL SYSTEM

A/T Electrical Parts Location

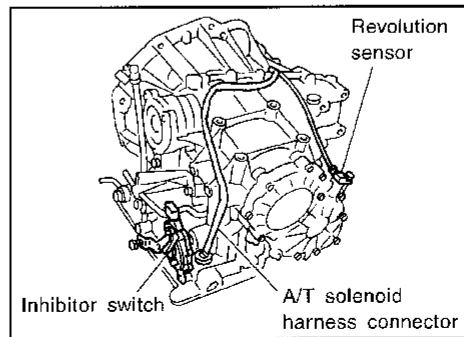
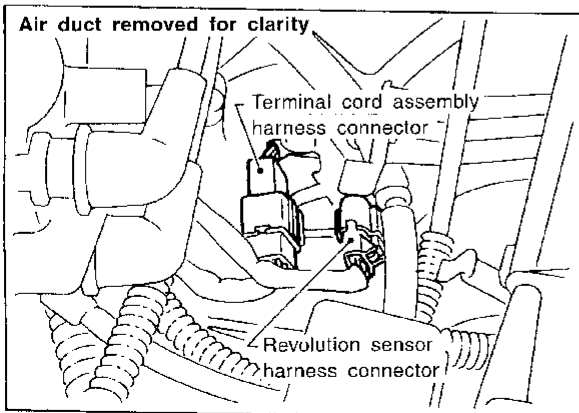
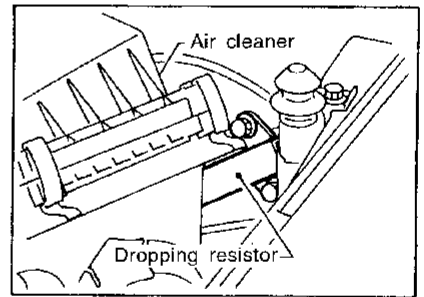
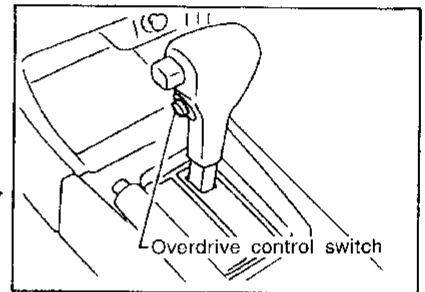
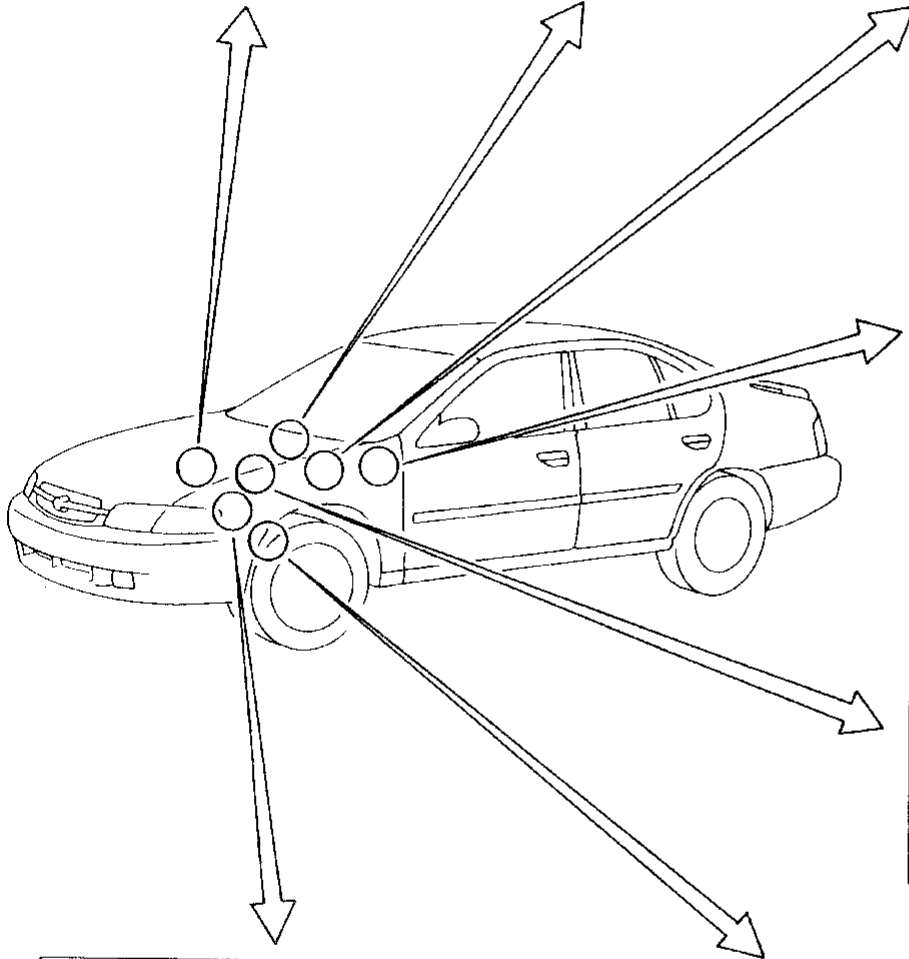
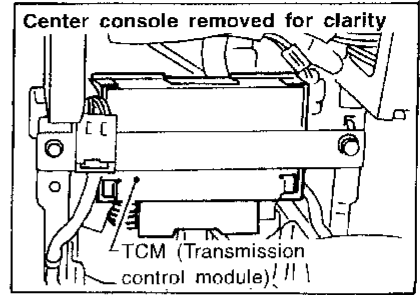
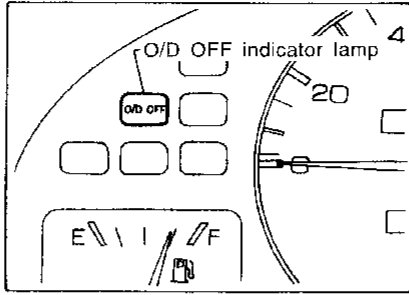
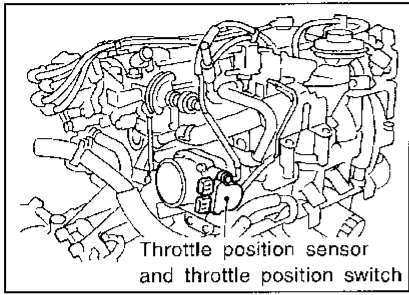

- GI
- MA
- EM
- LC
- EC
- FE
- CL
- MT
- AT**
- FA
- RA
- BR
- ST
- RS
- BT
- HA
- EL
- IDX

OVERALL SYSTEM

Circuit Diagram for Quick Pinpoint Check

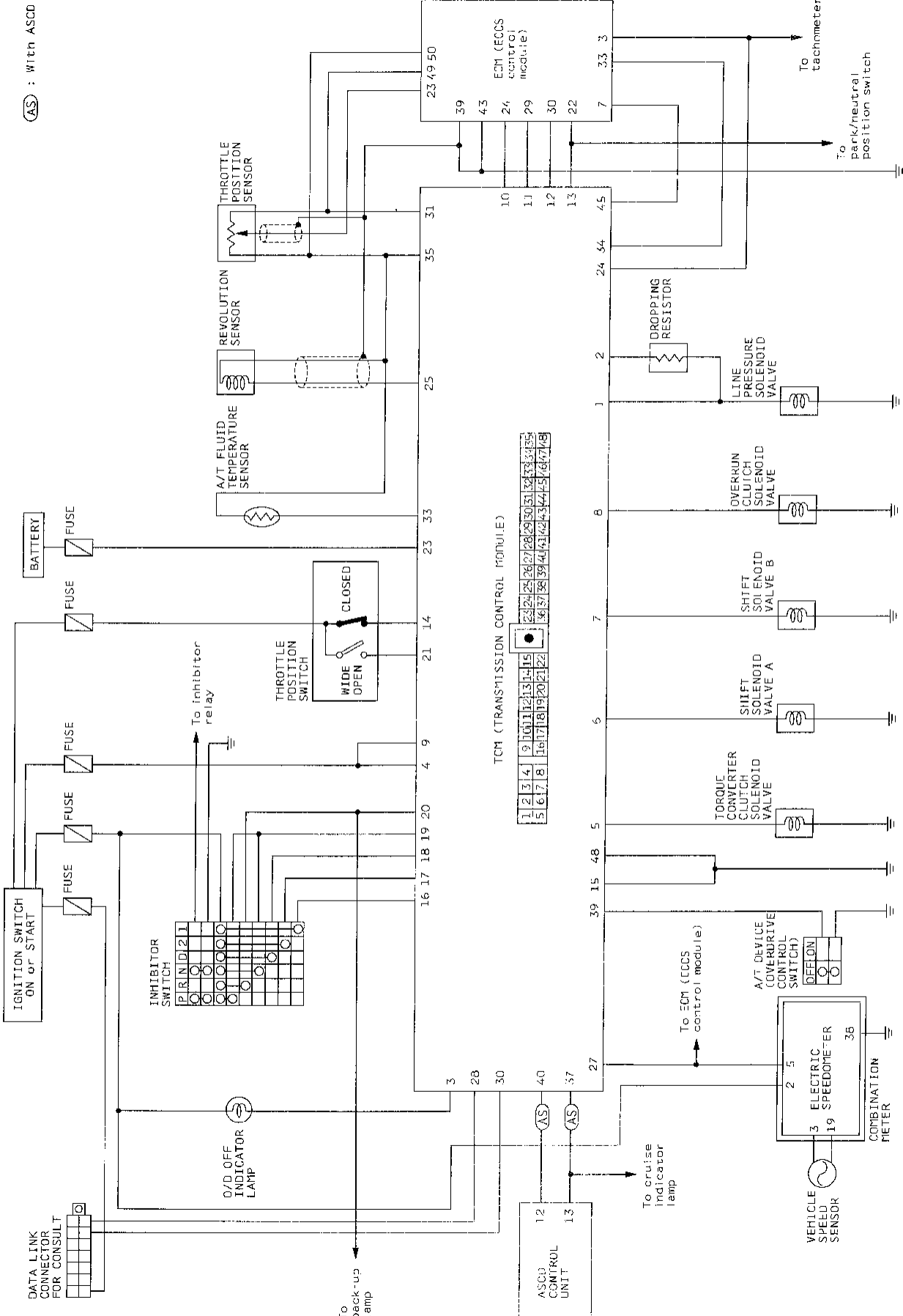

OVERALL SYSTEM

Cross-sectional View

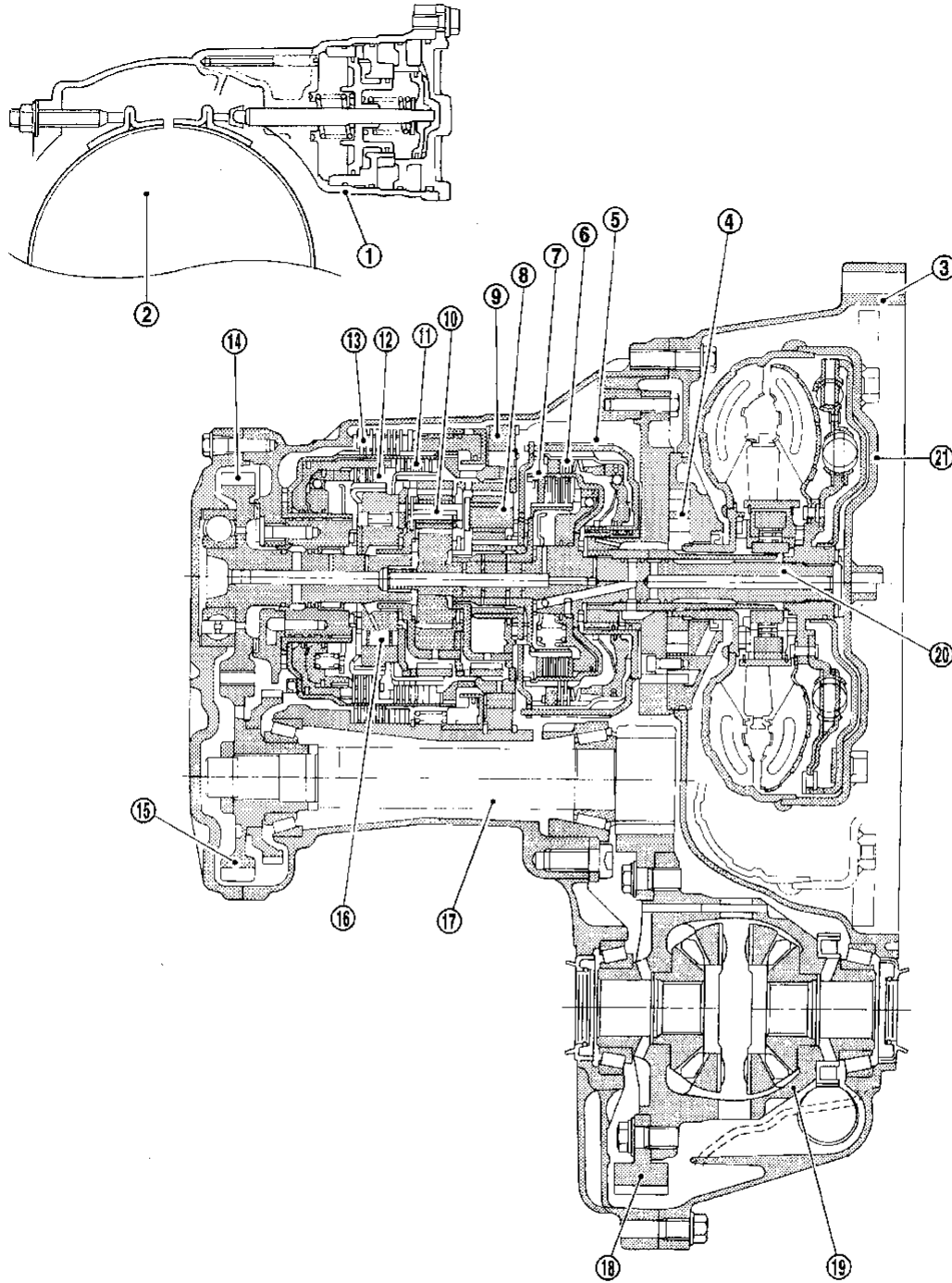

GI
MA
EM
LC
EC
FE
CL
WT
AT
FA
RA
BR
ST
RS
BT
HA
FL
IDX

SAT9011

- | | | |
|-----------------------|------------------------|--------------------------|
| ① Band servo piston | ⑧ Front planetary gear | ⑮ Idler gear |
| ② Reverse clutch drum | ⑨ Low one-way clutch | ⑯ Forward one-way clutch |
| ③ Converter housing | ⑩ Rear planetary gear | ⑰ Pinion reduction gear |
| ④ Oil pump | ⑪ Forward clutch | ⑱ Final gear |
| ⑤ Brake band | ⑫ Overrun clutch | ⑲ Differential case |
| ⑥ Reverse clutch | ⑬ Low & reverse brake | ⑳ Input shaft |
| ⑦ High clutch | ⑭ Output gear | ㉑ Torque converter |

OVERALL SYSTEM

Hydraulic Control Circuit

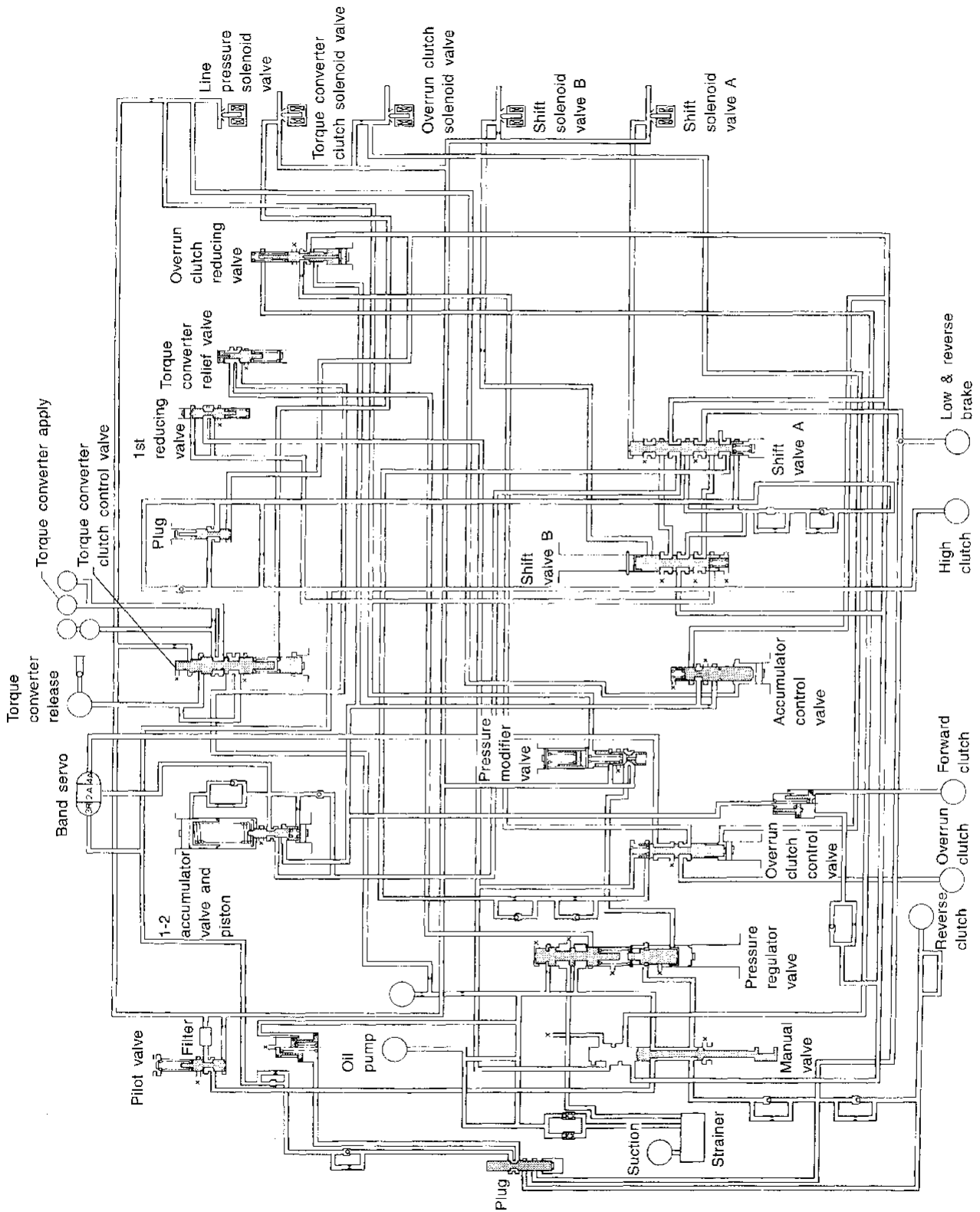

OVERALL SYSTEM

Shift Mechanism CONSTRUCTION

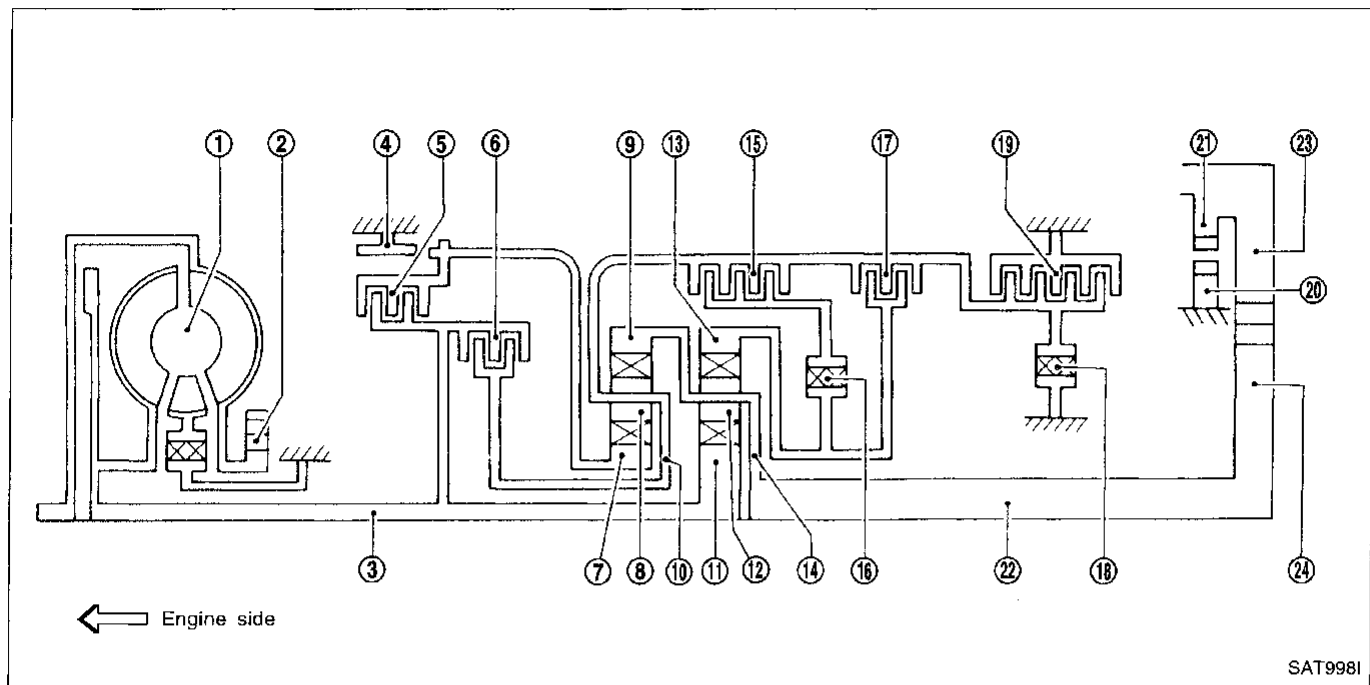

- ① Torque converter
- ② Oil pump
- ③ Input shaft
- ④ Brake band
- ⑤ Reverse clutch
- ⑥ High clutch
- ⑦ Front sun gear
- ⑧ Front pinion gear

- ⑨ Front internal gear
- ⑩ Front planetary carrier
- ⑪ Rear sun gear
- ⑫ Rear pinion gear
- ⑬ Rear internal gear
- ⑭ Rear planetary carrier
- ⑮ Forward clutch
- ⑯ Forward one-way clutch

- ⑰ Overrun clutch
- ⑱ Low one-way clutch
- ⑲ Low & reverse brake
- ⑳ Parking pawl
- ㉑ Parking gear
- ㉒ Output shaft
- ㉓ Idle gear
- ㉔ Output gear

GI
MA
EM
LC
EC
FE
CL
MT
AT
FA
RA
BR
ST
RS
BT
HA
EL
IDX

OVERALL SYSTEM

Shift Mechanism (Cont'd)

POWER TRANSMISSION

"N" and "P" positions

- "N" position
Power from the input shaft is not transmitted to the output shaft because the clutches do not operate.
- "P" position
Similar to the "N" position, the clutches do not operate. The parking pawl engages with the parking gear to mechanically hold the output shaft so that the power train is locked.

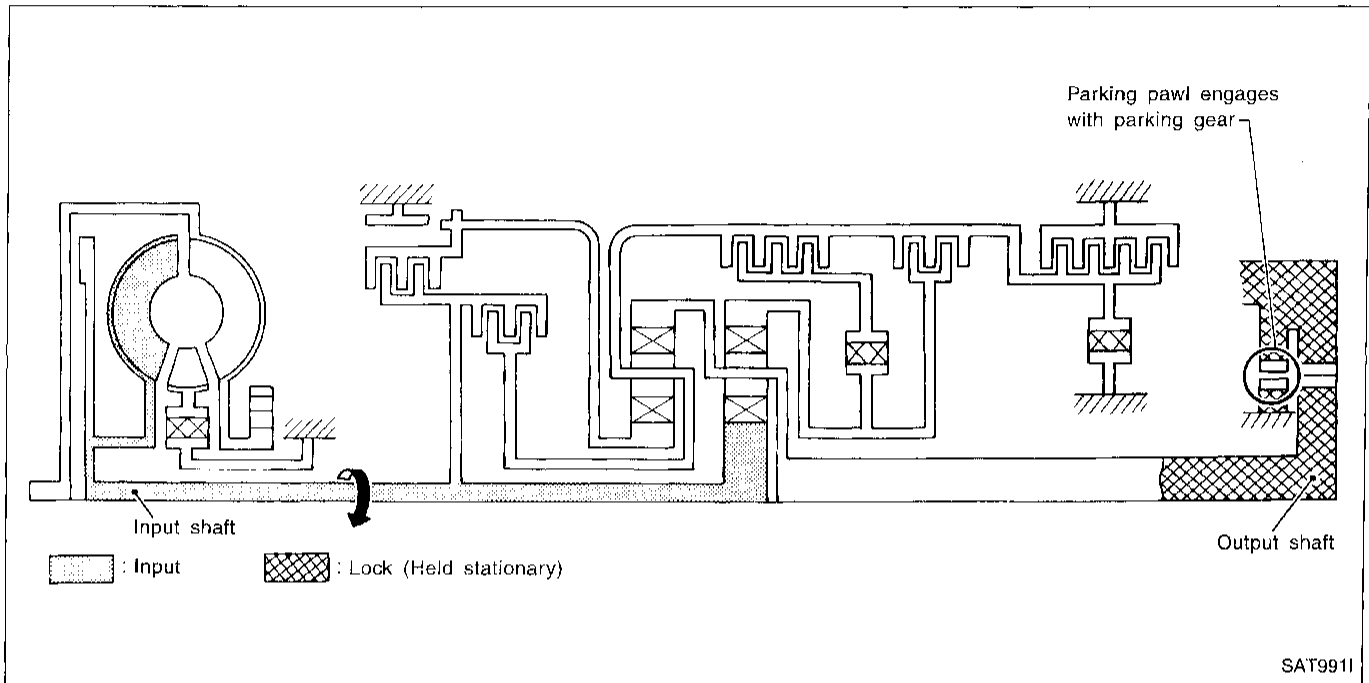

OVERALL SYSTEM

Shift Mechanism (Cont'd)

"1," position

<ul style="list-style-type: none"> ● Forward clutch ● Forward one-way clutch ● Overrun clutch ● Low and reverse brake 	<p>As overrun clutch engages, rear internal gear is locked by the operation of low and reverse brake.</p> <p>This is different from that of D_1 and 2_1.</p>
<p>Engine brake</p>	<p>Overrun clutch always engages, therefore engine brake can be obtained when decelerating.</p>
<p>Power flow</p>	<pre> Input shaft ↓ Rear sun gear ↓ Rear pinion gear ↓ Rear planetary carrier ↓ Output shaft </pre>

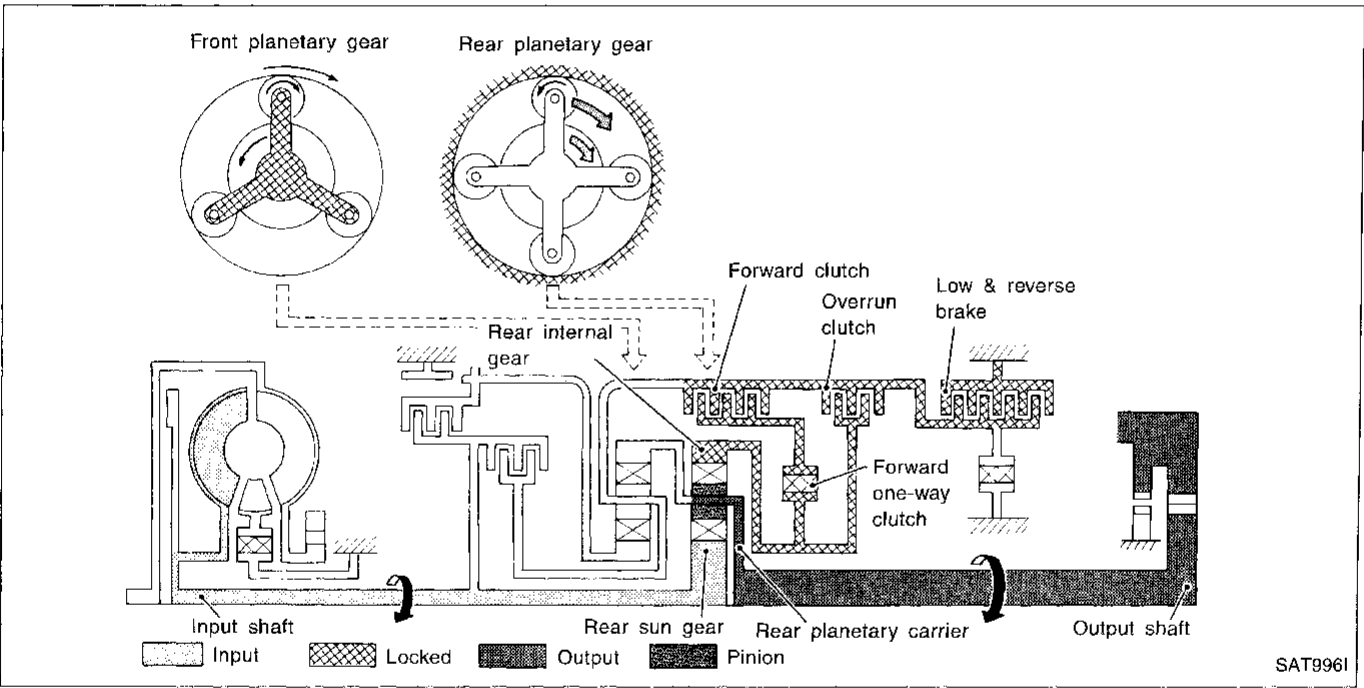

OVERALL SYSTEM

Shift Mechanism (Cont'd)

"D₁" and "2₁" positions

<ul style="list-style-type: none"> ● Forward one-way clutch ● Forward clutch ● Low one-way clutch 	Rear internal gear is locked to rotate counterclockwise because of the functioning of these three clutches.
Overrun clutch engagement conditions (Engine brake)	D ₁ : Overdrive control switch "OFF" and throttle opening is less than 3/16 2 ₁ : Always engaged At D ₁ and 2 ₁ positions, engine brake is not activated due to free turning of low one-way clutch.
Power flow	<pre> Input shaft ↓ Rear sun gear ↓ Rear planetary carrier ↓ Output shaft </pre>

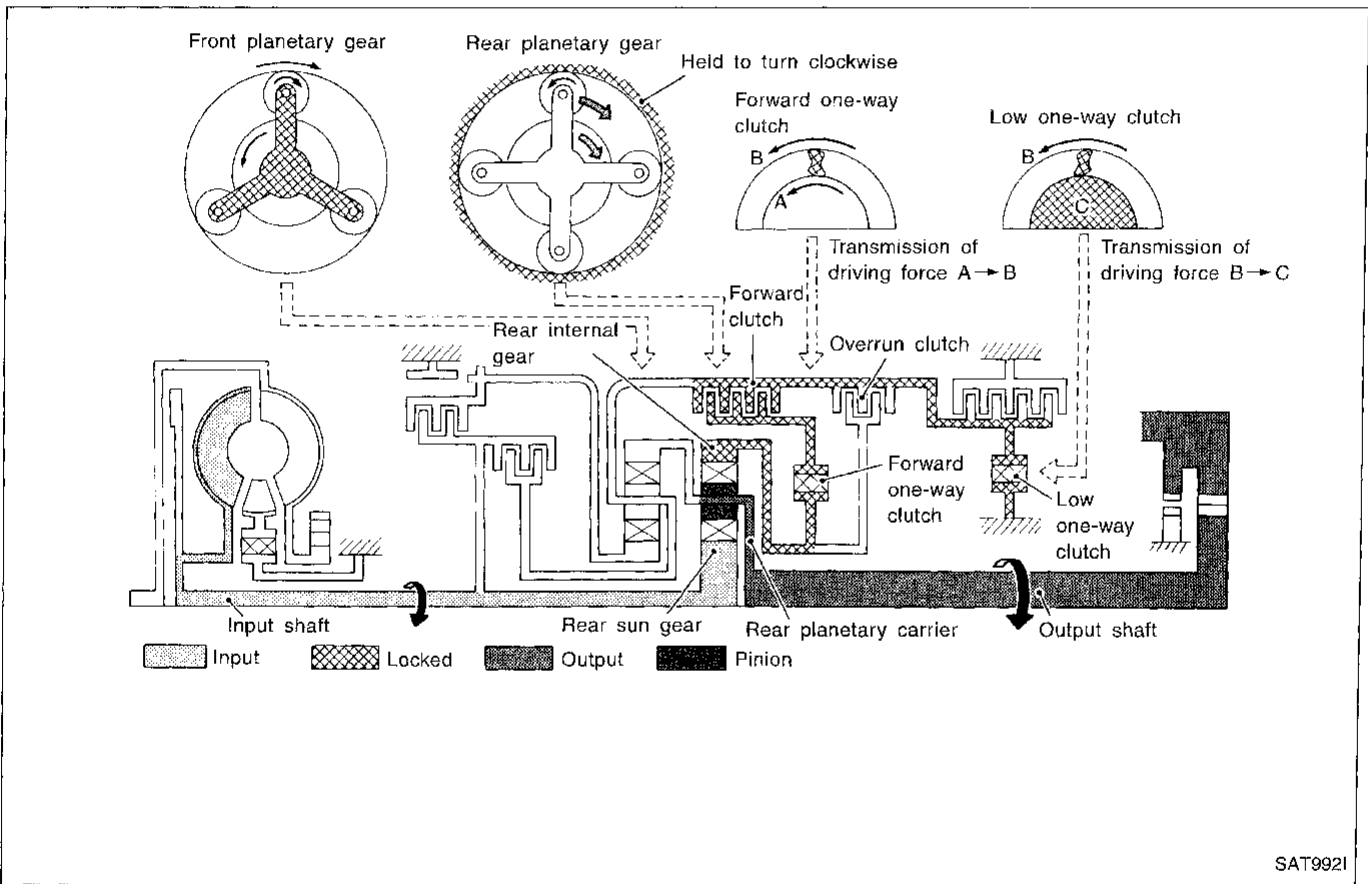

SAT9921

OVERALL SYSTEM

Shift Mechanism (Cont'd)

"D₂", "2₂" and "1₂" positions

<ul style="list-style-type: none"> • Forward clutch • Forward one-way clutch • Brake band 	<p>Rear sun gear drives rear planetary carrier and combined front internal gear. Front internal gear now rotates around front sun gear accompanying front planetary carrier.</p> <p>As front planetary carrier transfers the power to rear internal gear through forward clutch and forward one-way clutch, this rotation of rear internal gear increases the speed of rear planetary carrier compared with that of the 1st speed.</p>
<p>Overrun clutch engagement conditions</p>	<p>D₂: Overdrive control switch "OFF" and throttle opening is less than 3/16 2₂ and 1₂: Always engaged</p>
<p>Power flow</p>	<pre> graph TD IS[Input shaft] --> RS[Rear sun gear] RS --> RP[Rear pinion gear] RP --> RPC[Rear planetary carrier] RPC --> OS[Output shaft] RPC --> FI[Front internal gear] FI --> FP[Front pinion gear] FP --> FPC[Front planetary carrier] FPC --> FC[Forward clutch] FC --> FOC[Forward one-way clutch] FOC --> RI[Rear internal gear] RI --> RP </pre>

GI
MA
EM
LC
EC
FE
CL
MT
AT
FA
RA
BR
ST
RS
BT
HA
EL
IDX

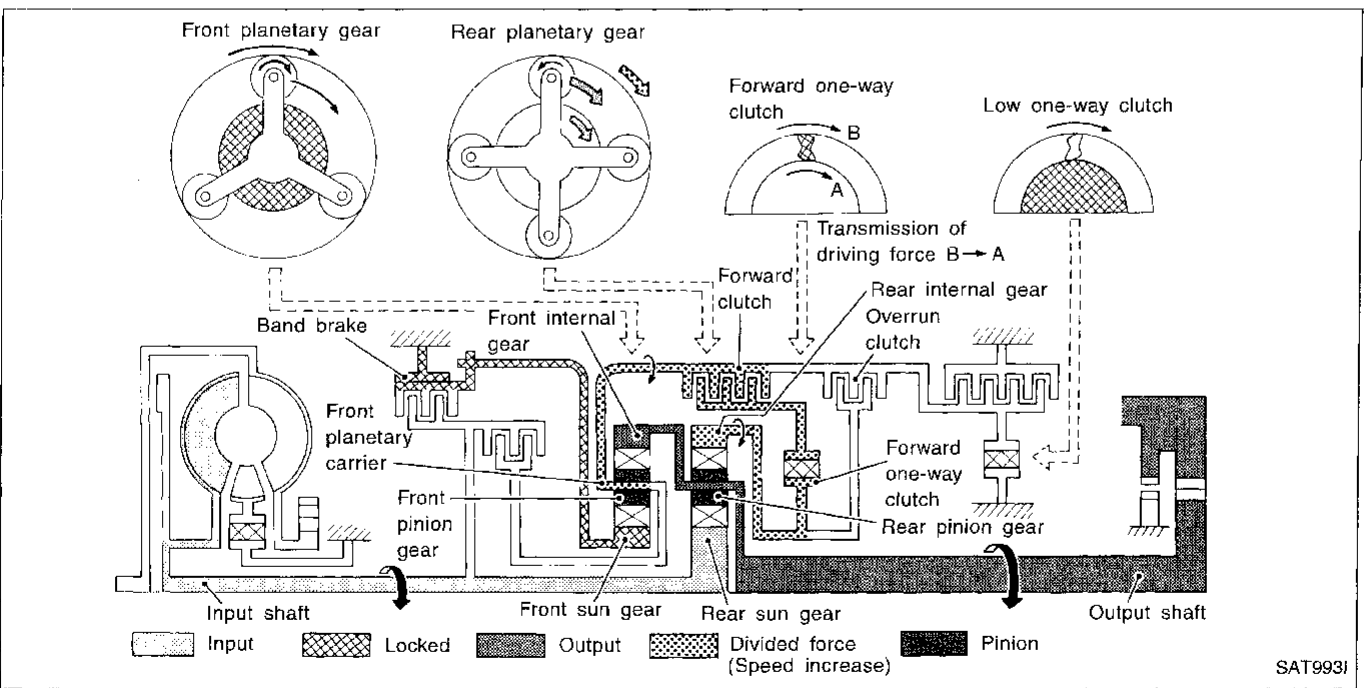

OVERALL SYSTEM

Shift Mechanism (Cont'd)

"D₃" position

<ul style="list-style-type: none"> ● High clutch ● Forward clutch ● Forward one-way clutch 	<p>Input power is transmitted to front planetary carrier through high clutch. And front planetary carrier is connected to rear internal gear by operation of forward clutch and forward one-way clutch. This rear internal gear rotation and another input (the rear sun gear) accompany rear planetary carrier to turn at the same speed.</p>
<p>Overrun clutch engagement conditions</p>	<p>D₃: Overdrive control switch "OFF" and throttle opening is less than 3/16</p>
<p>Power flow</p>	<pre> graph TD IS[Input shaft] --> HC[High clutch] IS --> RS[Rear sun gear] HC --> FC[Front carrier] FC --> FW[Forward clutch] FW --> FOW[Forward one-way clutch] FOW --> RI[Rear internal gear] RI --> RP[Rear pinion gear] RS --> RP RP --> RPC[Rear planetary carrier] RPC --> OS[Output shaft] </pre>

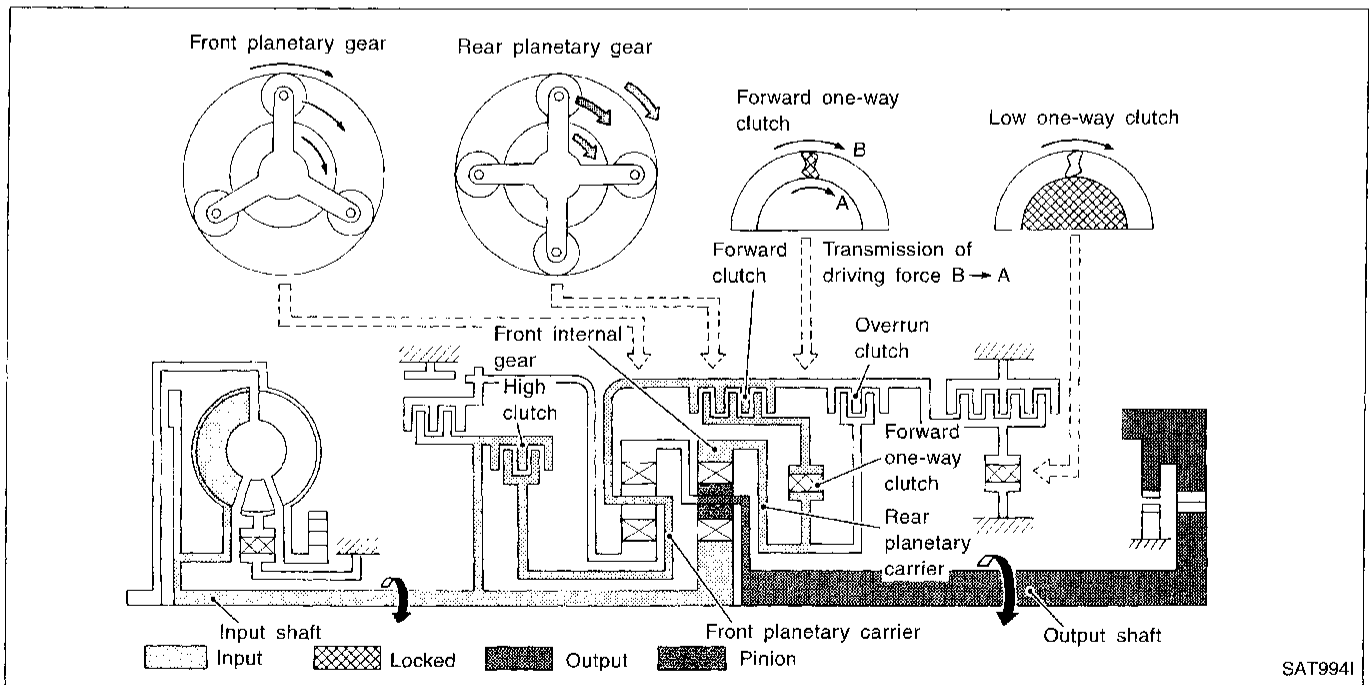

OVERALL SYSTEM

Shift Mechanism (Cont'd)

"D₄" (OD) position

<ul style="list-style-type: none"> ● High clutch ● Brake band ● Forward clutch (Does not affect power transmission) 	<p>Input power is transmitted to front carrier through high clutch. This front carrier turns around the sun gear which is fixed by brake band and makes front internal gear (output) turn faster.</p>
<p>Engine brake</p>	<p>At D₄ position, there is no one-way clutch in the power transmission line and engine brake can be obtained when decelerating.</p>
<p>Power flow</p>	<pre> Input shaft ↓ High clutch ↓ Front planetary carrier ↓ Front pinion gear ↓ Front internal gear ↓ Rear planetary carrier ↓ Output shaft </pre>

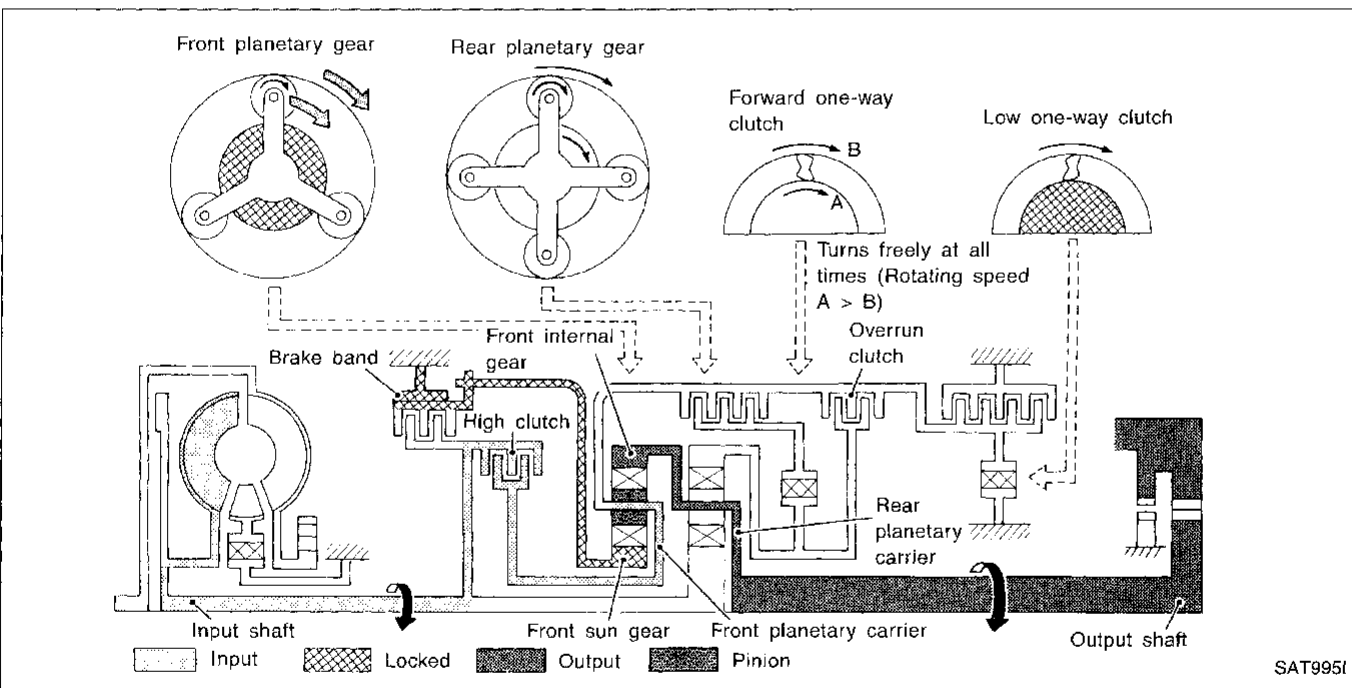

OVERALL SYSTEM

Shift Mechanism (Cont'd)

"R" position

<ul style="list-style-type: none">● Reverse clutch● Low and reverse brake	Front planetary carrier is stationary because of the operation of low and reverse brake. Input power is transmitted to front sun gear through reverse clutch, which drives front internal gear in the opposite direction.
Engine brake	As there is no one-way clutch in the power transmission line, engine brake can be obtained when decelerating.
Power flow	<p style="text-align: center;">Input shaft ↓ Reverse clutch ↓ Front sun gear ↓ Front pinion gear ↓ Front internal gear ↓ Output shaft</p>

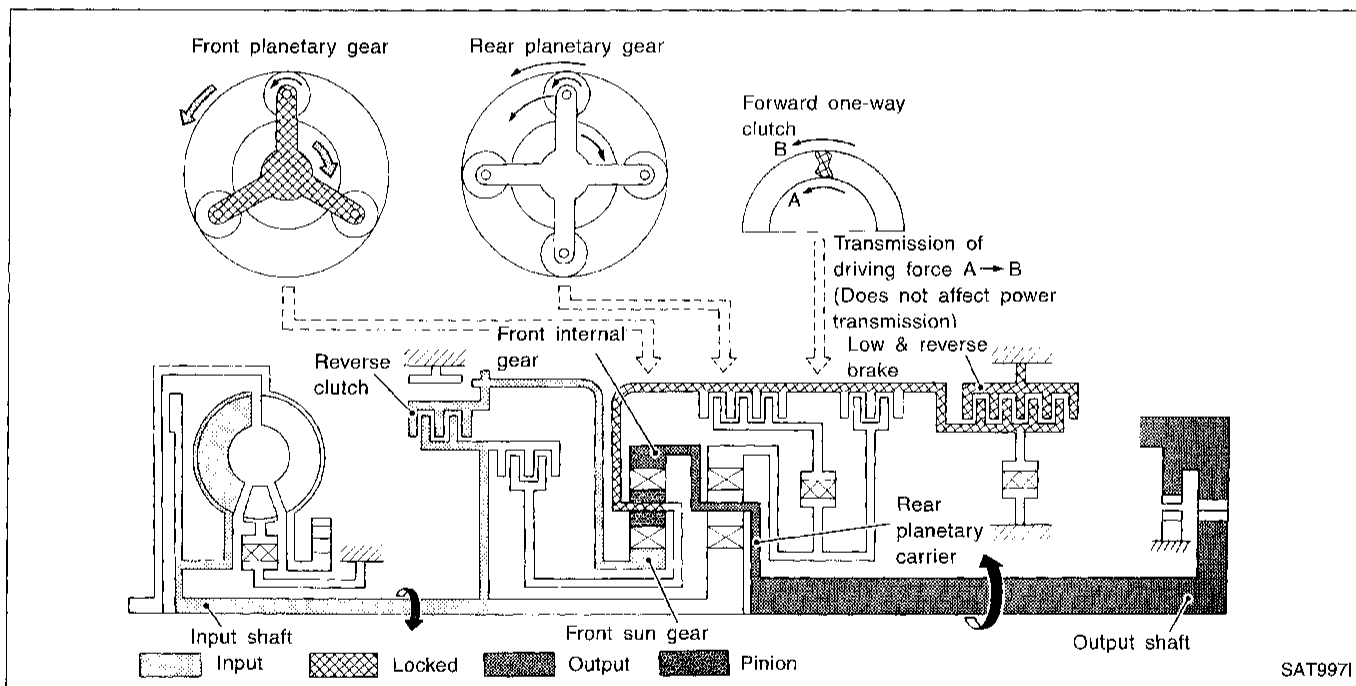

OVERALL SYSTEM

Shift Mechanism (Cont'd)

FUNCTION OF CLUTCH AND BRAKE

Clutch and brake components	Abbr.	Function
⑤ Reverse clutch	R/C	To transmit input power to front sun gear ⑦.
⑥ High clutch	H/C	To transmit input power to front planetary carrier ⑩.
⑮ Forward clutch	F/C	To connect front planetary carrier ⑩ with forward one-way clutch ⑮.
⑰ Overrun clutch	O/C	To connect front planetary carrier ⑩ with rear internal gear ⑬.
④ Brake band	B/B	To lock front sun gear ⑦.
⑯ Forward one-way clutch	F/O.C	When forward clutch ⑮ is engaged, to stop rear internal gear ⑬ from rotating in opposite direction against engine revolution.
⑱ Low one-way clutch	L/O.C	To stop front planetary carrier ⑩ from rotating in opposite direction against engine revolution.
⑲ Low & reverse brake	L & R/B	To lock front planetary carrier ⑩.

CLUTCH AND BAND CHART

Shift position	Reverse clutch ⑤	High clutch ⑥	Forward clutch ⑮	Overrun clutch ⑰	Band servo			Forward one-way clutch ⑯	Low one-way clutch ⑱	Low & reverse brake ⑲	Lock-up	Remarks
					2nd apply	3rd release	4th apply					
P												PARK POSITION
R	○									○		REVERSE POSITION
N												NEUTRAL POSITION
D*4	1st		○	*1⊗				●	●			Automatic shift 1 ↔ 2 ↔ 3 ↔ 4
	2nd		○	*1⊙	○			●				
	3rd		○	○	*1⊙	*2⊗	⊗	●			*5○	
	4th		○	⊗		*3⊗	⊗	○			○	
2	1st		○	⊗				●	●			Automatic shift 1 ↔ 2 ↔ 3
	2nd		○	⊙	○			●				
1	1st		○	○				●		○		Locks (held stationary) in 1st speed 1 ← 2 ← 3
	2nd		○	○	○			●				

*1: Operates when overdrive control switch is set in "OFF" position.

*2: Oil pressure is applied to both 2nd "apply" side and 3rd "release" side of band servo piston. However, brake band does not contract because oil pressure area on the "release" side is greater than that on the "apply" side.

*3: Oil pressure is applied to 4th "apply" side in condition *2 above, and brake band contracts.

*4: A/T will not shift to 4th when overdrive control switch is set in "OFF" position.

*5: Operates when overdrive control switch is "OFF".

○ : Operates

⊙ : Operates when throttle opening is less than 3/16, activating engine brake.

● : Operates during "progressive" acceleration.

⊗ : Operates but does not affect power transmission.

⊗ : Operates when throttle opening is less than 3/16, but does not affect engine brake.

OVERALL SYSTEM

Control System

OUTLINE

The automatic transaxle senses vehicle operating conditions through various sensors. It always controls the optimum shaft position and reduces shifting and lock-up shocks.

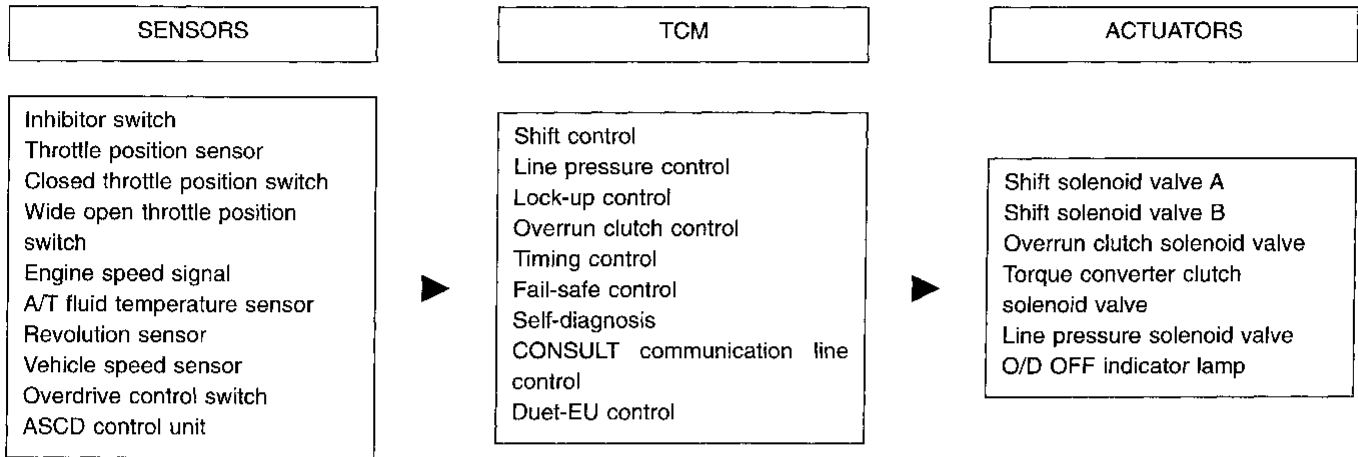

CONTROL SYSTEM

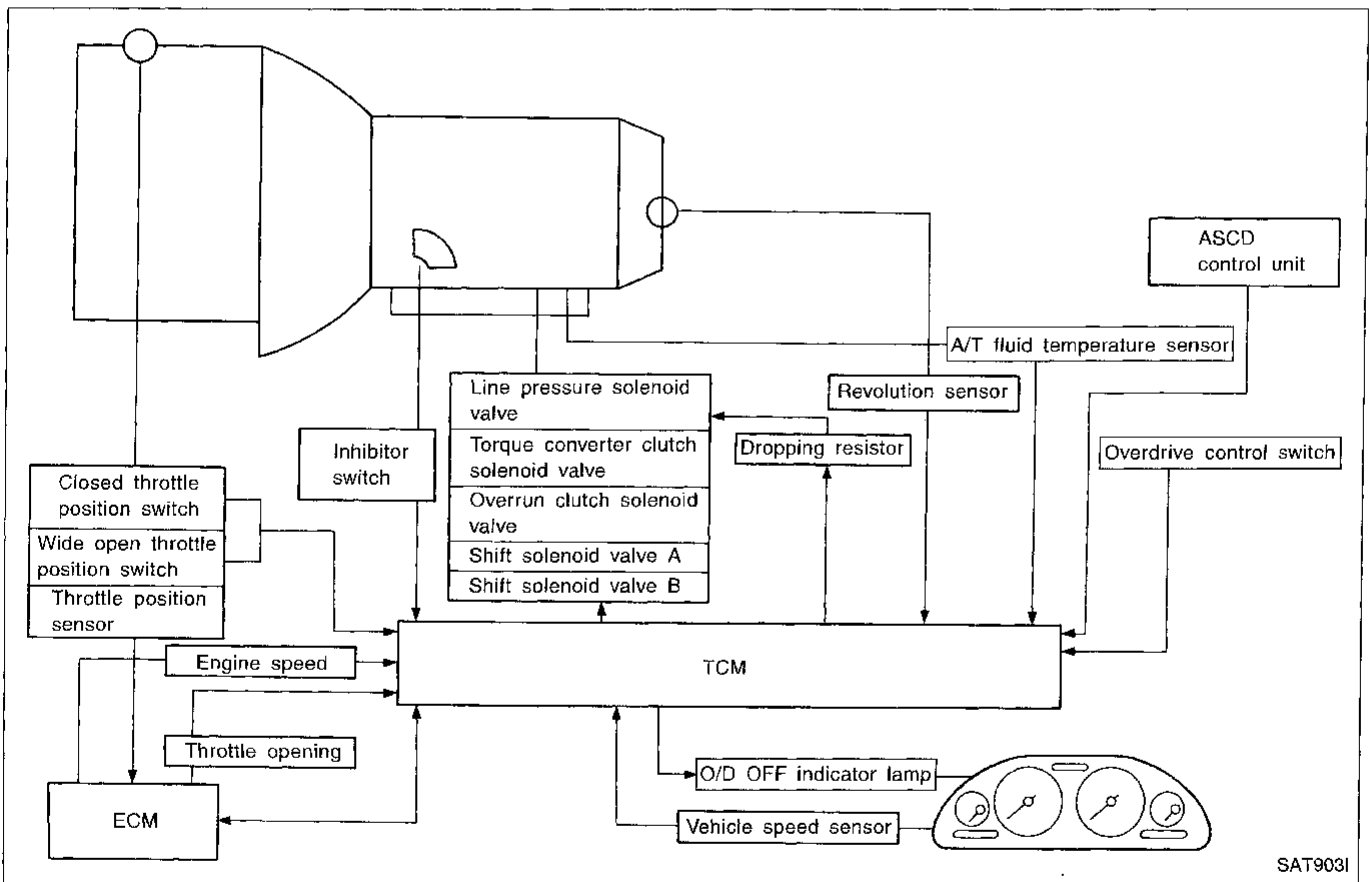

OVERALL SYSTEM

Control System (Cont'd)

TCM FUNCTION

The function of the TCM is to:

- Receive input signals sent from various switches and sensors.
- Determine required line pressure, shifting point, lock-up operation, and engine brake operation.
- Send required output signals to the respective solenoids.

INPUT/OUTPUT SIGNAL OF TCM

	Sensors and solenoid valves	Function	
Input	Inhibitor switch	Detects select lever position and sends a signal to TCM.	GI
	Throttle position sensor	Detects throttle valve position and sends a signal to TCM.	MA
	Closed throttle position switch	Detects throttle valve's fully-closed position and sends a signal to TCM.	EM
	Wide open throttle position switch	Detects a throttle valve position of greater than 1/2 of full throttle and sends a signal to TCM.	LC
	Engine speed signal	From ECM (ECCS control module).	EC
	A/T fluid temperature sensor	Detects transmission fluid temperature and sends a signal to TCM.	FE
	Revolution sensor	Detects output shaft rpm and sends a signal to TCM.	CL
	Vehicle speed sensor	Used as an auxiliary vehicle speed sensor. Sends a signal when revolution sensor (installed on transmission) malfunctions.	CL
	Overdrive control switch	Sends a signal, which prohibits a shift to "D ₄ " (overdrive) position, to the TCM.	MT
ASCD control unit	Sends the cruise signal and D ₄ (overdrive) cancellation signal from ASCD control unit to TCM.	MT	
Output	Shift solenoid valve A/B	Selects shifting point suited to driving conditions in relation to a signal sent from TCM.	AT
	Line pressure solenoid valve	Regulates (or decreases) line pressure suited to driving conditions in relation to a signal sent from TCM.	FA
	Torque converter clutch solenoid valve	Regulates (or decreases) lock-up pressure suited to driving conditions in relation to a signal sent from TCM.	RA
	Overrun clutch solenoid valve	Controls an "engine brake" effect suited to driving conditions in relation to a signal sent from TCM.	RA
	O/D OFF indicator lamp	Shows TCM faults, when A/T control components malfunction.	BR

ST

RS

BT

HA

EL

IDX

Control Mechanism

LINE PRESSURE CONTROL

TCM has various line pressure control characteristics to match the driving conditions.

An ON-OFF duty signal is sent to the line pressure solenoid valve based on TCM characteristics.

Hydraulic pressure on the clutch and brake is electronically controlled through the line pressure solenoid valve to accommodate engine torque. This results in smooth shift operation.

Normal control

The line pressure to throttle opening characteristics is set for suitable clutch operation.

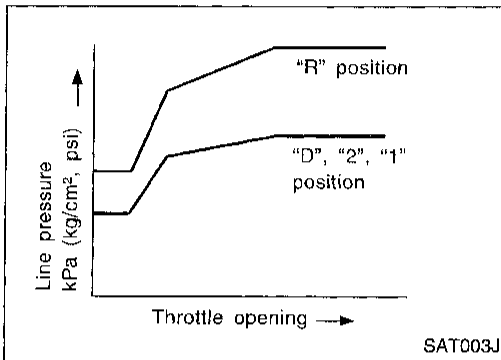

Back-up control (Engine brake)

If the selector lever is shifted to "2" position while driving in D_4 (OD) or D_3 , great driving force is applied to the clutch inside the transmission. Clutch operating pressure (line pressure) must be increased to deal with this driving force.

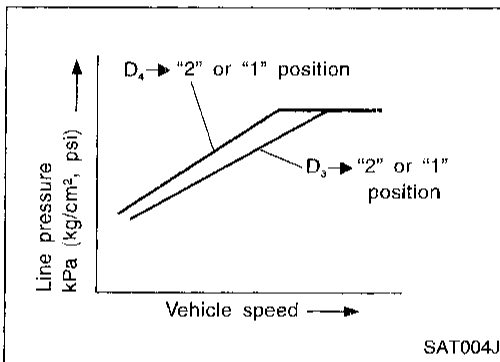

During shift change

The line pressure is temporarily reduced corresponding to a change in engine torque when shifting gears (that is, when the shift solenoid valve is switched for clutch operation) to reduce shifting shock.

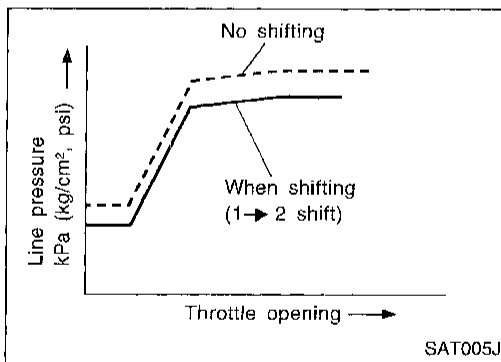

At low fluid temperature

- Fluid viscosity and frictional characteristics of the clutch facing change with fluid temperature. Clutch engaging or band-contacting pressure is compensated for, according to fluid temperature, to stabilize shifting quality.

OVERALL SYSTEM

Control Mechanism (Cont'd)

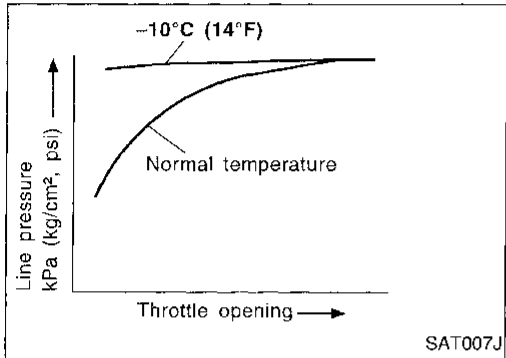
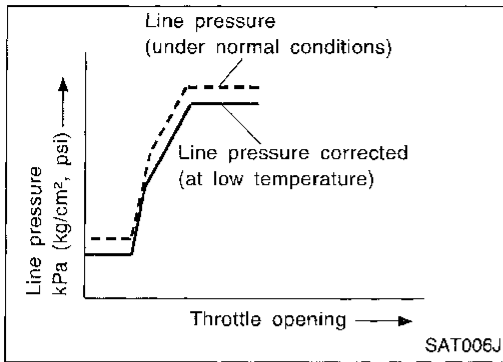

- The line pressure is reduced below 60°C (140°F) to prevent shifting shock due to low viscosity of automatic transmission fluid when temperature is low.

- Line pressure is increased to a maximum irrespective of the throttle opening when fluid temperature drops to -10°C (14°F). This pressure rise is adopted to prevent a delay in clutch and brake operation due to extreme drop of fluid viscosity at low temperature.

SHIFT CONTROL

The shift is regulated entirely by electronic control to accommodate vehicle speed and varying engine operations. This is accomplished by electrical signals transmitted by the revolution sensor and throttle position sensor. This results in improved acceleration performance and fuel economy.

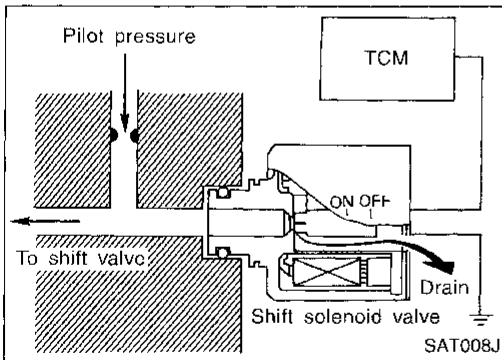

Control of shift solenoid valves A and B

The TCM activates shift solenoid valves A and B according to signals from the throttle position sensor and revolution sensor to select the optimum gear position on the basis of the shift schedule memorized in the TCM.

The shift solenoid valve performs simple ON-OFF operation. When set to ON, the drain circuit closes and pilot pressure is applied to the shift valve.

Relation between shift solenoid valves A and B and gear positions

Gear position	D ₁ , 2 ₁ , 1 ₁	D ₂ , 2 ₂ , 1 ₂	D ₃	D ₄ (OD)	N-P
Shift solenoid valve					
A	ON (Closed)	OFF (Open)	OFF (Open)	ON (Closed)	ON (Closed)
B	ON (Closed)	ON (Closed)	OFF (Open)	OFF (Open)	ON (Closed)

OVERALL SYSTEM

Control Mechanism (Cont'd)

Control of shift valves A and B

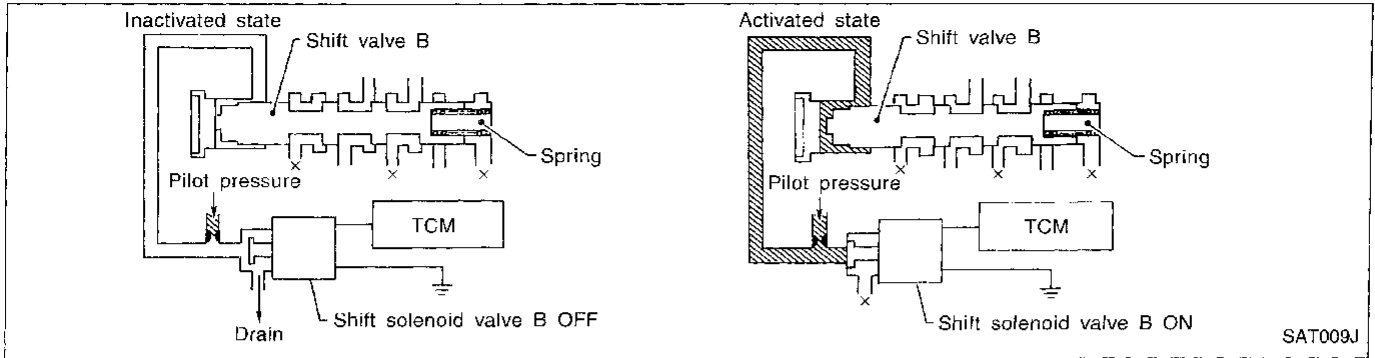

Pilot pressure generated by the operation of shift solenoid valves A and B is applied to the end face of shift valves A and B.

The drawing above shows the operation of shift valve B. When the shift solenoid valve is ON, pilot pressure applied to the end face of the shift valve overcomes spring force, moving the valve upward.

LOCK-UP CONTROL

The lock-up piston in the torque converter is locked to eliminate torque converter slip to increase power transmission efficiency. The solenoid valve is controlled by an ON-OFF duty signal sent from the TCM. The signal is converted to an oil pressure signal which controls the lock-up piston.

Conditions for lock-up operation

When vehicle is driven in 4th gear position, vehicle speed and throttle opening are detected. If the detected values fall within the lock-up zone memorized in the TCM, lock-up is performed.

Overdrive control switch	ON	OFF
Selector lever	"D" position	
Gear position	D ₄	D ₃
Vehicle speed sensor	More than set value	
Throttle position sensor	Less than set opening	
Closed throttle position switch	OFF	
A/T fluid temperature sensor	More than 40°C (104°F)	

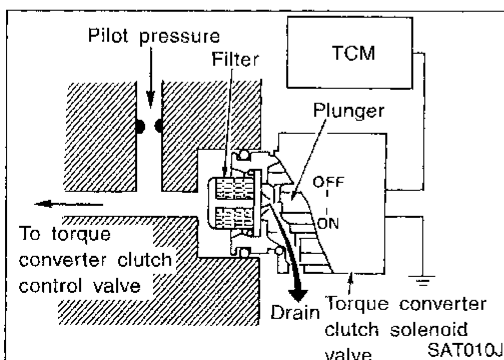

Torque converter clutch solenoid valve control

The torque converter clutch solenoid valve is controlled by the TCM. The plunger closes the drain circuit during the OFF period, and opens the circuit during the ON period. If the percentage of OFF-time increases in one cycle, the pilot pressure drain time is reduced and pilot pressure remains high.

The lock-up piston is designed to slip to adjust the ratio of ON-OFF, thereby reducing lock-up shock.

OVERALL SYSTEM

Control Mechanism (Cont'd)

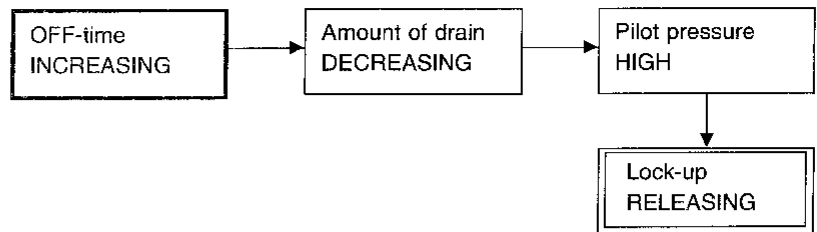
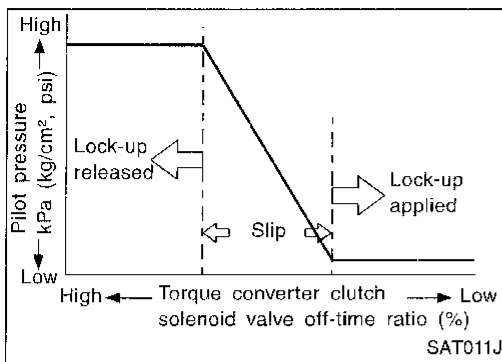

Torque converter clutch control valve operation

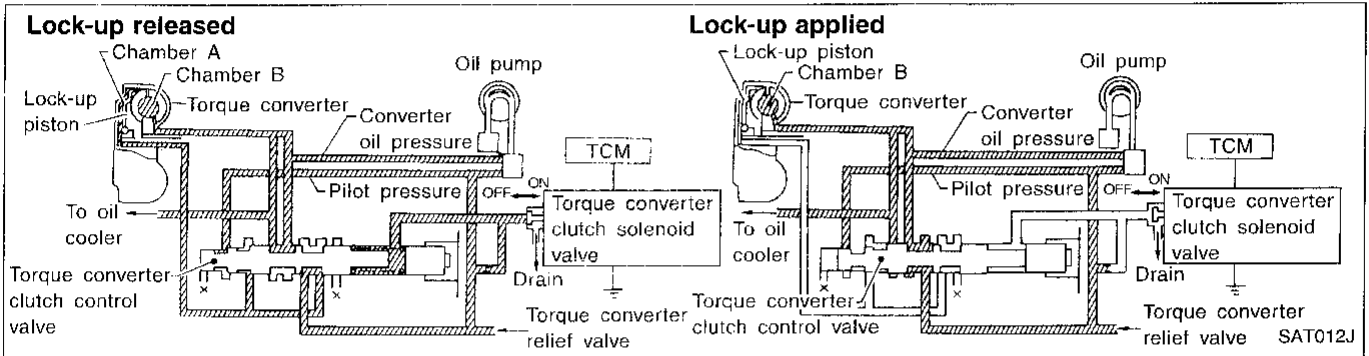

Lock-up released

The OFF-duration of the torque converter clutch solenoid valve is long, and pilot pressure is high. The pilot pressure pushes the end face of the torque converter clutch control valve in combination with spring force to move the valve to the left. As a result, converter pressure is applied to chamber A (lock-up piston release side). Accordingly, the lock-up piston remains unlocked.

Lock-up applied

When the OFF-duration of the torque converter clutch solenoid valve is short, pilot pressure drains and becomes low. Accordingly, the control valve moves to the right by the pilot pressure of the other circuit and converter pressure. As a result, converter pressure is applied to chamber B, keeping the lock-up piston applied.

Also smooth lock-up is provided by transient application and release of the lock-up.

OVERRUN CLUTCH CONTROL (ENGINE BRAKE CONTROL)

Forward one-way clutch is used to reduce shifting shocks in downshifting operations. This clutch transmits engine torque to the wheels. However, drive force from the wheels is not transmitted to the engine because the one-way clutch rotates idle. This means the engine brake is not effective.

The overrun clutch operates when the engine brake is needed.

Overrun clutch operating conditions

	Gear position	Throttle opening
"D" position	D ₁ , D ₂ , D ₃ gear position	Less than 3/16
"2" position	2 ₁ , 2 ₂ gear position	
"1" position	1 ₁ , 1 ₂ gear position	At any position

OVERALL SYSTEM

Control Mechanism (Cont'd)

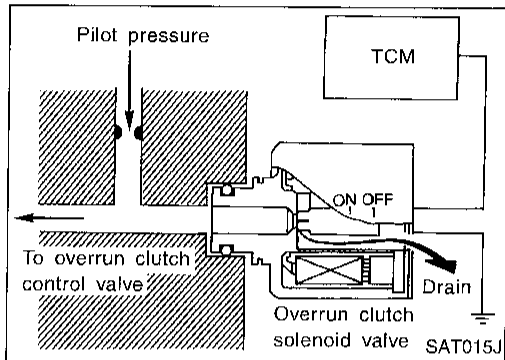
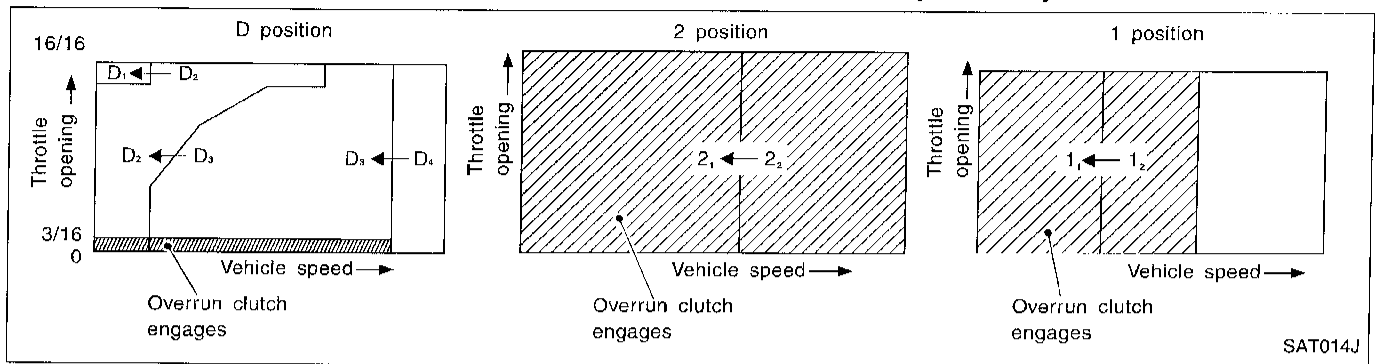

Overrun clutch solenoid valve control

The overrun clutch solenoid valve is operated by an ON-OFF signal transmitted by the TCM to provide overrun clutch control (engine brake control).

When this solenoid valve is ON, the pilot pressure drain port closes. When it is OFF, the drain port opens.

During the solenoid valve ON pilot pressure is applied to the end face of the overrun clutch control valve.

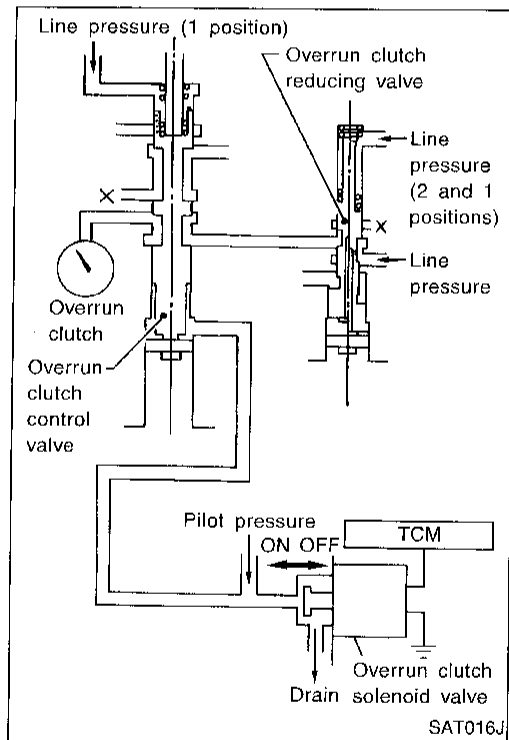

Overrun clutch control valve operation

When the solenoid valve is ON, pilot pressure is applied to the overrun clutch control valve. This pushes up the overrun clutch control valve. The line pressure is then shut off so that the clutch does not engage.

When the solenoid is OFF, pilot pressure is not generated. At this point, the overrun clutch control valve moves downward by spring force. As a result, overrun clutch operation pressure is provided by the overrun clutch reducing valve. This causes the overrun clutch to engage.

In the 1 position, the overrun clutch control valve remains pushed down so that the overrun clutch is engaged at all times.

OVERALL SYSTEM

Control Valve

FUNCTION OF CONTROL VALVES

Valve name	Function
Pressure regulator valve, plug and sleeve	Regulates oil discharged from the oil pump to provide optimum line pressure for all driving conditions.
Pressure modifier valve and sleeve	Used as a signal supplementary valve to the pressure regulator valve. Regulates pressure-modifier pressure (signal pressure) which controls optimum line pressure for all driving conditions.
Pilot valve	Regulates line pressure to maintain a constant pilot pressure level which controls lock-up mechanism, overrun clutch, shift timing.
Accumulator control valve	Regulates accumulator backpressure to pressure suited to driving conditions.
Manual valve	Directs line pressure to oil circuits corresponding to select positions. Hydraulic pressure drains when the shift lever is in Neutral.
Shift valve A	Simultaneously switches four oil circuits using output pressure of shift solenoid valve A to meet driving conditions (vehicle speed, throttle opening, etc.). Provides automatic downshifting and up-shifting (1st→2nd→3rd→4th gears/4th→3rd→2nd→1st gears) in combination with shift valve B.
Shift valve B	Simultaneously switches three oil circuits using output pressure of shift solenoid valve B in relation to driving conditions (vehicle speed, throttle opening, etc.). Provides automatic downshifting and up-shifting (1st→2nd→3rd→4th gears/4th→3rd→2nd→1st gears) in combination with shift valve A.
Overrun clutch control valve	Switches hydraulic circuits to prevent engagement of the overrun clutch simultaneously with application of the brake band in D ₄ . (Interlocking occurs if the overrun clutch engages during D ₄ .)
"1" reducing valve	Reduces low & reverse brake pressure to dampen engine-brake shock when down-shifting from the "1" position 1 ₂ to 1 ₁ .
Overrun clutch reducing valve	Reduces oil pressure directed to the overrun clutch and prevents engine-brake shock. In "1" and "2" positions, line pressure acts on the overrun clutch reducing valve to increase the pressure-regulating point, with resultant engine brake capability.
Torque converter relief valve	Prevents an excessive rise in torque converter pressure.
Torque converter clutch control valve, plug and sleeve	Activates or inactivates the lock-up function. Also provides smooth lock-up through transient application and release of the lock-up system.
1-2 accumulator valve and piston	Dampens the shock encountered when 2nd gear band servo contracts, and provides smooth shifting.

GI

MA

EM

LC

EC

FE

CL

MT

AT

FA

RA

BR

ST

RS

BT

HA

EL

IDX

Introduction

The A/T system has two self-diagnostic systems.

The first is the emission-related on board diagnostic system (OBD-II) performed by the TCM (transmission control module) in combination with the ECM (ECCS control module). The malfunction is indicated by the MIL (malfunction indicator lamp) and is stored as a DTC in the ECM memory but not the TCM memory.

The second is the TCM original self-diagnosis indicated by the O/D OFF indicator lamp. The malfunction is stored in the TCM memory. The detected items are overlapped with OBD-II self-diagnostic items. For detail, refer to AT-45.

OBD-II Function for A/T System

The ECM (ECCS control module) provides emission-related on board diagnostic (OBD-II) functions for the A/T system. One function is to receive a signal from the TCM used with OBD-related parts of the A/T system. The signal is sent to the ECM when a malfunction occurs in the corresponding OBD-related part. The other function is to indicate a diagnostic result by means of the MIL (malfunction indicator lamp) on the instrument panel. Sensors, switches and solenoid valves are used as sensing elements.

The MIL automatically illuminates in One or Two Trip Detection Logic when a malfunction is sensed in relation to A/T system parts.

One or Two Trip Detection Logic of OBD-II

ONE TRIP DETECTION LOGIC

If a malfunction is sensed during the first test drive, the MIL will illuminate and the malfunction will be stored in the ECM memory as a DTC. The TCM is not provided with such a memory function.

TWO TRIP DETECTION LOGIC

When a malfunction is sensed during the first test drive, it is stored in the ECM memory as a 1st trip DTC (diagnostic trouble code) or 1st trip freeze frame data. At this point, the MIL will not illuminate. — First Trip

If the same malfunction as that experienced during the first test drive is sensed during the second test drive, the MIL will illuminate. — Second Trip

A/T-related parts for which the MIL illuminates during the first or second test drive are listed below.

Items	MIL	
	One trip detection	Two trip detection
Shift solenoid valve A — DTC: P0750 (1108)	X	
Shift solenoid valve B — DTC: P0755 (1201)	X	
Throttle position sensor or switch — DTC: P1705 (1206)	X	
Except above		X

The “trip” in the “One or Two Trip Detection Logic” means a driving mode in which self-diagnosis is performed during vehicle operation.

OBD-II Diagnostic Trouble Code (DTC)

How to read DTC and 1st trip DTC

DTC and 1st trip DTC can be read by the following methods.

 1. The number of blinks of the malfunction indicator lamp in the Diagnostic Test Mode II (Self-Diagnostic Results) Examples: 1101, 1102, 1103, 1104, etc. For details, refer to EC section [“Malfunction Indicator Lamp (MIL)”, “ON BOARD DIAGNOSTIC SYSTEM DESCRIPTION”]. These DTCs are controlled by NISSAN.

 2. CONSULT or GST (Generic Scan Tool) Examples: P0705, P0710, P0720, P0725, etc. These DTCs are prescribed by SAE J2012.

 (CONSULT also displays the malfunctioning component or system.)

ON BOARD DIAGNOSTIC SYSTEM DESCRIPTION

OBD-II Diagnostic Trouble Code (DTC) (Cont'd)

- 1st trip DTC No. is the same as DTC No.
- Output of the diagnostic trouble code indicates that the indicated circuit has a malfunction. However, in case of the Mode II and GST they do not indicate whether the malfunction is still occurring or occurred in the past and returned to normal. CONSULT can identify them as shown below. Therefore, using CONSULT (if available) is recommended.

GI

MA

EM

LC

EC

FE

CL

MT

AT

FA

RA

BR

ST

RS

BT

HA

EL

IDX

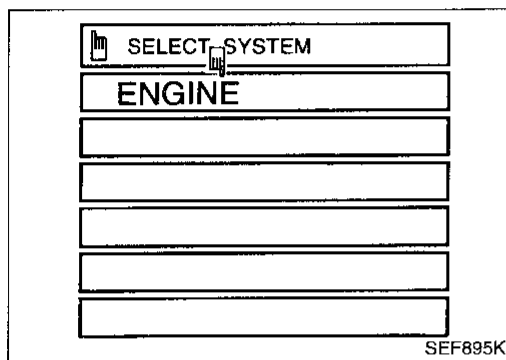

A sample of CONSULT display for DTC is shown at left. DTC or 1st trip DTC of a malfunction is displayed in SELF-DIAGNOSTIC RESULTS mode for "ENGINE" with CONSULT. Time data indicates how many times the vehicle was driven after the last detection of a DTC.

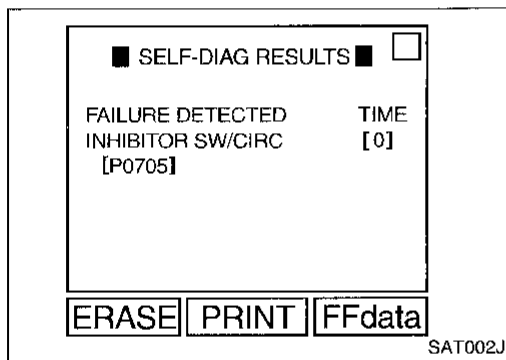

If the DTC is being detected currently, the time data will be "0".

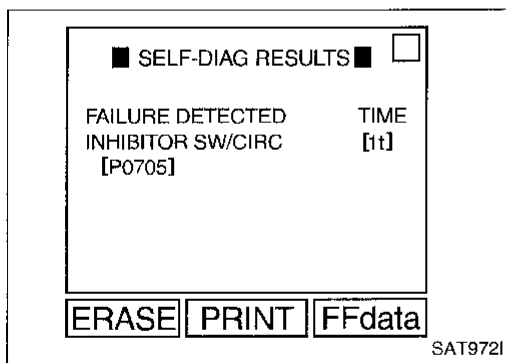

If a 1st trip DTC is stored in the ECM, the time data will be "[1t]".

ON BOARD DIAGNOSTIC SYSTEM DESCRIPTION

OBD-II Diagnostic Trouble Code (DTC) (Cont'd)

FREEZE FRAME DATA AND 1ST TRIP FREEZE FRAME DATA

The ECM has a memory function, which stores the driving condition such as fuel system status, calculated load value, engine coolant temperature, short term fuel trim, long term fuel trim, engine speed and vehicle speed at the moment the ECM detects a malfunction.

Data which are stored in the ECM memory, along with the 1st trip DTC, are called 1st trip freeze frame data, and the data, stored together with the DTC data, are called freeze frame data and displayed on CONSULT or GST. The 1st trip freeze frame data can only be displayed on the CONSULT screen, not on the GST. For detail, refer to EC section (“CONSULT”, “ON BOARD DIAGNOSTIC SYSTEM DESCRIPTION”).

Only one set of freeze frame data (either 1st trip freeze frame data or freeze frame data) can be stored in the ECM. 1st trip freeze frame data is stored in the ECM memory along with the 1st trip DTC. There is no priority for 1st trip freeze frame data and it is updated each time a different 1st trip DTC is detected. However, once freeze frame data (2nd trip detection/MIL on) is stored in the ECM memory, 1st trip freeze frame data is no longer stored. Remember, only one set of freeze frame data can be stored in the ECM. The ECM has the following priorities to update the data.

Priority	Items	
1	Freeze frame data	Misfire — DTC: P0300 - P0306 (0701, 0603 - 0608) Fuel Injection System Function — DTC: P0171 (0115), P0172 (0114), P0174 (0209), P0175 (0210)
2		Except the above items (Includes A/T related items)
3	1st trip freeze frame data	

Both 1st trip freeze frame data and freeze frame data (along with the DTCs) are cleared when the ECM memory is erased.

HOW TO ERASE DTC

The diagnostic trouble code can be erased by CONSULT, GST or ECM DIAGNOSTIC TEST MODE as described following.

- **If the battery terminal is disconnected, the diagnostic trouble code will be lost within 24 hours.**
- **When you erase the DTC, using CONSULT or GST is easier and quicker than switching the mode selector on the ECM.**

The following emission-related diagnostic information is cleared from the ECM memory when erasing DTC related to OBD-II. For details, refer to EC section (“Emission-related Diagnostic Information”, “ON BOARD DIAGNOSTIC SYSTEM DESCRIPTION”).

- **Diagnostic trouble codes (DTC)**
- **1st trip diagnostic trouble codes (1st trip DTC)**
- **Freeze frame data**
- **1st trip freeze frame data**
- **System readiness test (SRT) codes**
- **Test values**

HOW TO ERASE DTC (With CONSULT)

- **If a DTC is displayed for both ECM and TCM, it needs to be erased for both ECM and TCM.**
1. If the ignition switch stays “ON” after repair work, be sure to turn ignition switch “OFF” once. Wait at least 5 seconds and then turn it “ON” (engine stopped) again.
 2. Turn CONSULT “ON” and touch “A/T”.
 3. Touch “SELF-DIAG RESULTS”.
 4. Touch “ERASE”. (The DTC in the TCM will be erased.) Then touch “BACK” twice.
 5. Touch “ENGINE”.
 6. Touch “SELF-DIAG RESULTS”.
 7. Touch “ERASE”. (The DTC in the ECM will be erased.)

ON BOARD DIAGNOSTIC SYSTEM DESCRIPTION

OBD-II Diagnostic Trouble Code (DTC) (Cont'd)

How to erase DTC (With CONSULT)

1. If the ignition switch stays "ON" after repair work, be sure to turn ignition switch "OFF" once. Wait at least 5 seconds and then turn it "ON" (engine stopped) again.

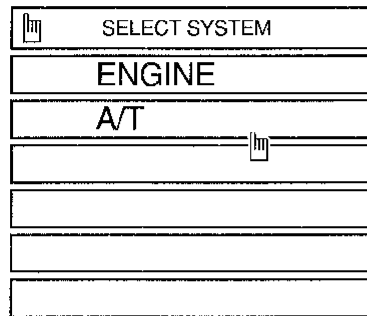

2. Turn CONSULT "ON", and touch "A/T".

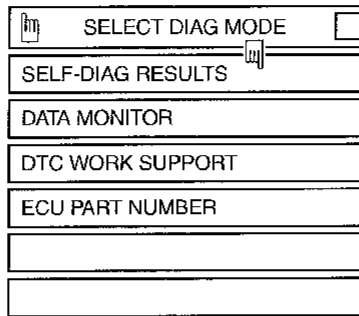

3. Touch "SELF-DIAG RESULTS".

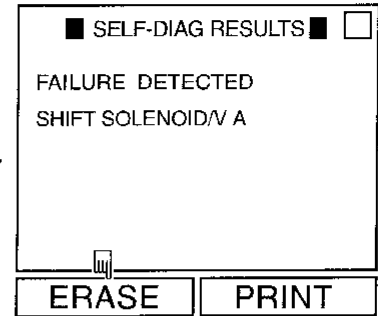

4. Touch "ERASE". (The DTC in the TCM will be erased.)

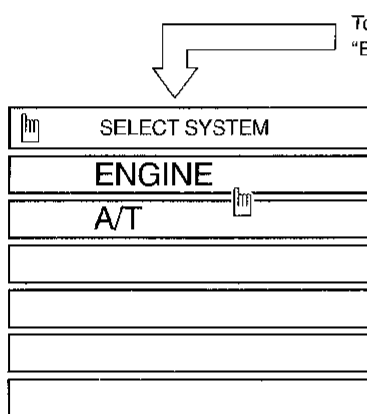

5. Touch "ENGINE".

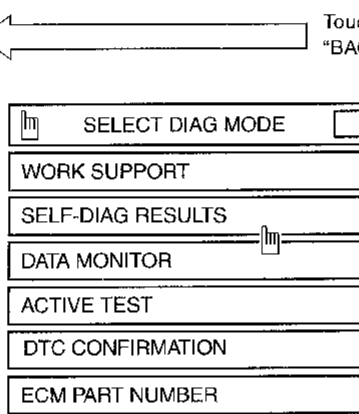

6. Touch "SELF-DIAG RESULTS".

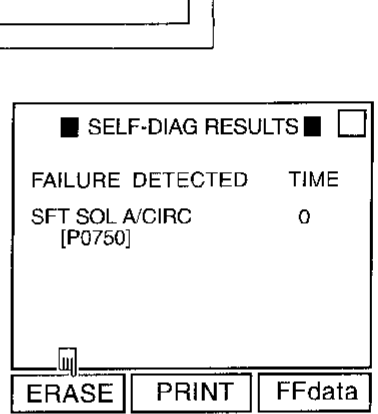

7. Touch "ERASE". (The DTC in the ECM will be erased.)

SAT904I

HOW TO ERASE DTC (With GST)

1. If the ignition switch stays "ON" after repair work, be sure to turn ignition switch "OFF" once. Wait at least 5 seconds and then turn it "ON" (engine stopped) again.
2. Perform "OBD-II SELF-DIAGNOSTIC PROCEDURE (No Tools)". Refer to AT-43. (The engine warm-up step can be skipped when performing the diagnosis only to erase the DTC.)
3. Select Mode 4 with Generic Scan Tool (GST). For details, refer to EC section ["Generic Scan Tool (GST)", "ON BOARD DIAGNOSTIC SYSTEM DESCRIPTION"].

HOW TO ERASE DTC (No Tools)

1. If the ignition switch stays "ON" after repair work, be sure to turn ignition switch "OFF" once. Wait at least 5 seconds and then turn it "ON" (engine stopped) again.
2. Perform "TCM SELF-DIAGNOSTIC PROCEDURE (No Tools)". Refer to AT-43. (The engine warm-up step can be skipped when performing the diagnosis only to erase the DTC.)
3. Change the diagnostic test mode from Mode II to Mode I by turning the mode selector on the ECM. Refer to EC section ["HOW TO SWITCH DIAGNOSTIC TEST MODES", "Malfunction Indicator Lamp (MIL)", "ON BOARD DIAGNOSTIC SYSTEM DESCRIPTION"].

GI
MA
EW
LC
EC
FE
CL
MT
AT
FA
RA
BR
ST
RS
BT
HA
EL
IDX

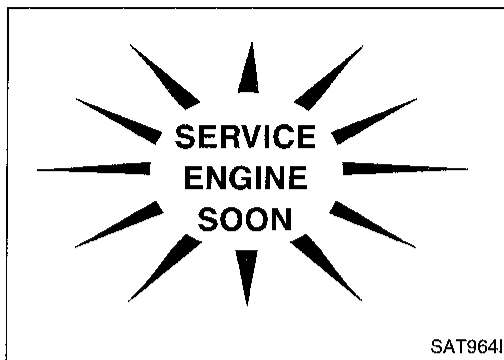

Malfunction Indicator Lamp (MIL)

1. The malfunction indicator lamp will light up when the ignition switch is turned ON without the engine running. This is for checking the lamp.
 - If the malfunction indicator lamp does not light up, refer to EL section ("Warning Lamps/System Description", "WARNING LAMPS AND CHIME"). (Or see MIL & Data Link Connectors in EC section.)
2. When the engine is started, the malfunction indicator lamp should go off. If the lamp remains on, the on board diagnostic system has detected an emission-related (OBD-II) malfunction. For detail, refer to EC section ("ON BOARD DIAGNOSTIC SYSTEM DESCRIPTION").

CONSULT

NOTICE

1. The CONSULT electrically displays shift timing and lock-up timing (that is, operation timing of each solenoid).

Check for time difference between actual shift timing and the CONSULT display. If the difference is noticeable, mechanical parts (except solenoids, sensors, etc.) may be malfunctioning. Check mechanical parts using applicable diagnostic procedures.
2. Shift schedule (which implies gear position) displayed on CONSULT and that indicated in Service Manual may differ slightly. This occurs because of the following reasons:
 - Actual shift schedule has more or less tolerance or allowance,
 - Shift schedule indicated in Service Manual refers to the point where shifts start, and
 - Gear position displayed on CONSULT indicates the point where shifts are completed.
3. Shift solenoid valve "A" or "B" is displayed on CONSULT at the start of shifting. Gear position is displayed upon completion of shifting (which is computed by TCM).
4. Additional CONSULT information can be found in the Operation Manual supplied with the CONSULT unit.

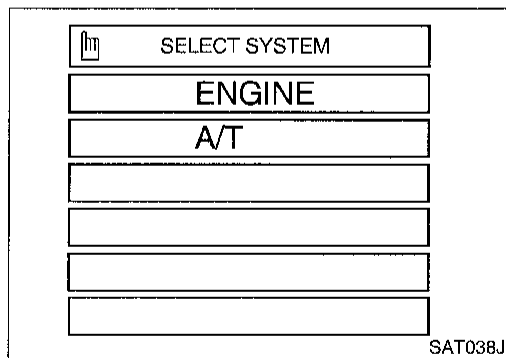

SELF-DIAGNOSIS

After performing this procedure, place check marks for results on the "DIAGNOSTIC WORKSHEET", AT-49. Reference pages are provided following the items.

SELF-DIAGNOSTIC PROCEDURE (With CONSULT)

1. Turn on CONSULT and touch "ENGINE" for OBD-II detected items or touch "A/T" for TCM self-diagnosis. If A/T is not displayed, check TCM power supply and ground circuit. Refer to AT-70. If result is NG, refer to EL section ("POWER SUPPLY ROUTING").

ON BOARD DIAGNOSTIC SYSTEM DESCRIPTION

CONSULT (Cont'd)

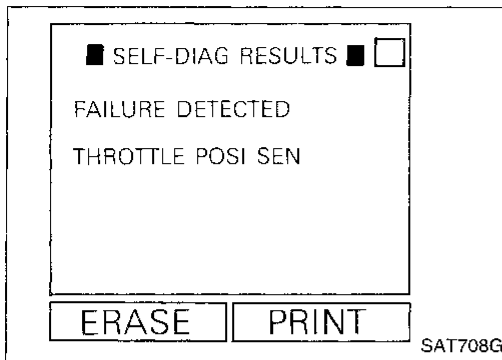

2. Touch "SELF-DIAG RESULTS".

Display shows malfunction experienced since the last erasing operation.

CONSULT performs REAL-TIME SELF-DIAGNOSIS.

Also, any malfunction detected while in this mode will be displayed at real time.

SELF-DIAGNOSTIC RESULT TEST MODE

Detected items (Screen terms for CONSULT, "SELF-DIAG RESULTS" test mode)		Malfunction is detected when ...	TCM self-diagnosis	OBD-II (DTC)
"A/T"	"ENGINE"		Available by O/D OFF indicator lamp or "A/T" on CONSULT	Available by malfunction indicator lamp*2, "ENGINE" on CONSULT or GST
Inhibitor switch circuit		● TCM does not receive the correct voltage signal (based on the gear position) from the switch.	—	P0705
—	INHIBITOR SW/CIRC			
Revolution sensor		● TCM does not receive the proper voltage signal from the sensor.	X	P0720
VHCL SPEED SEN-A/T	VEH SPD SEN/CIR AT			
Vehicle speed sensor (Meter)		● TCM does not receive the proper voltage signal from the sensor.	X	—
VHCL SPEED SEN-MTR	—			
A/T 1st gear function		● A/T cannot be shifted to the 1st gear position even if electrical circuit is good.	—	P0731*1
—	A/T 1ST GR FNCTN			
A/T 2nd gear function		● A/T cannot be shifted to the 2nd gear position even if electrical circuit is good.	—	P0732*1
—	A/T 2ND GR FNCTN			
A/T 3rd gear function		● A/T cannot be shifted to the 3rd gear position even if electrical circuit is good.	—	P0733*1
—	A/T 3RD GR FNCTN			
A/T 4th gear function		● A/T cannot be shifted to the 4th gear position even if electrical circuit is good.	—	P0734*1
—	A/T 4TH GR FNCTN			
A/T TCC S/V function (lock-up)		● A/T cannot perform lock-up even if electrical circuit is good.	—	P0744*1
—	A/T TCC S/V FNCTN			
Shift solenoid valve A		● TCM detects an improper voltage drop when it tries to operate the solenoid valve.	X	P0750
SHIFT SOLENOID/V A	SFT SOL A/CIRC			
Shift solenoid valve B		● TCM detects an improper voltage drop when it tries to operate the solenoid valve.	X	P0755
SHIFT SOLENOID/V B	SFT SOL B/CIRC			
Overrun clutch solenoid valve		● TCM detects an improper voltage drop when it tries to operate the solenoid valve.	X	P1760
OVERRUN CLUTCH S/V	O/R CLUCH SOL/CIRC			
T/C clutch solenoid valve		● TCM detects an improper voltage drop when it tries to operate the solenoid valve.	X	P0740
T/C CLUTCH SOL/V	TCC SOLENOID/CIRC			
Line pressure solenoid valve		● TCM detects an improper voltage drop when it tries to operate the solenoid valve.	X	P0745
LINE PRESSURE S/V	L/PRESS SOL/GRC			
Throttle position sensor, throttle position switch		● TCM receives an excessively low or high voltage from the sensor.	X	P1705
THROTTLE POSI SEN	TP SEN/CIRC A/T			
Engine speed signal		● TCM does not receive the proper voltage signal from the ECM.	X	P0725
ENGINE SPEED SIG	—			
A/T fluid temperature sensor		● TCM receives an excessively low or high voltage from the sensor.	X	P0710
BATT/FLUID TEMP SEN	ATF TEMP SEN/CIRC			
Initial start		● This is not a malfunction message (Whenever shutting off a power supply to the TCM, this message appears on the screen.)	X	—
INITIAL START	—			
No failure (NO SELF DIAGNOSTIC FAILURE INDICATED FURTHER TESTING MAY BE REQUIRED**)		● No failure has been detected.	X	X

X : Applicable

— : Not applicable

*1 : These malfunctions cannot be displayed by MIL if another malfunction is assigned to MIL.

*2 : Refer to EC section ["Malfunction Indicator Lamp (MIL)", "ON BOARD DIAGNOSTIC SYSTEM DESCRIPTION"].

ON BOARD DIAGNOSTIC SYSTEM DESCRIPTION

CONSULT (Cont'd)

DATA MONITOR MODE (A/T)

Item	Display	Monitor item		Description	Remarks
		ECU input signals	Main signals		
Vehicle speed sensor 1 (A/T) (Revolution sensor)	VHCL/S SE-A/T [km/h] or [mph]	X	—	● Vehicle speed computed from signal of revolution sensor is displayed.	When racing engine in "N" or "P" position with vehicle stationary, CONSULT data may not indicate 0 km/h (0 mph).
Vehicle speed sensor 2 (Meter)	VHCL/S SE-MTR [km/h] or [mph]	X	—	● Vehicle speed computed from signal of vehicle speed sensor is displayed.	Vehicle speed display may not be accurate under approx. 10 km/h (6 mph). It may not indicate 0 km/h (0 mph) when vehicle is stationary.
Throttle position sensor	THRTL POS SEN [V]	X	—	● Throttle position sensor signal voltage is displayed.	
A/T fluid temperature sensor	FLUID TEMP SE [V]	X	—	● A/T fluid temperature sensor signal voltage is displayed. ● Signal voltage lowers as fluid temperature rises.	
Battery voltage	BATTERY VOLT [V]	X	—	● Source voltage of TCM is displayed.	
Engine speed	ENGINE SPEED [rpm]	X	X	● Engine speed, computed from engine speed signal, is displayed.	Engine speed display may not be accurate under approx. 800 rpm. It may not indicate 0 rpm even when engine is not running.
Overdrive control switch	OVERDRIVE SW [ON/OFF]	X	—	● ON/OFF state computed from signal of overdrive control SW is displayed.	
P/N position switch	P/N POSI SW [ON/OFF]	X	—	● ON/OFF state computed from signal of P/N position SW is displayed.	
R position switch	R POSITION SW [ON/OFF]	X	—	● ON/OFF state computed from signal of R position SW is displayed.	
D position switch	D POSITION SW [ON/OFF]	X	—	● ON/OFF state computed from signal of D position SW is displayed.	
2 position switch	2 POSITION SW [ON/OFF]	X	—	● ON/OFF status, computed from signal of 2 position SW, is displayed.	
1 position switch	1 POSITION SW [ON/OFF]	X	—	● ON/OFF status, computed from signal of 1 position SW, is displayed.	
ASCD cruise signal	ASCD-CRUISE [ON/OFF]	X	—	● Status of ASCD cruise signal is displayed. ON ... Cruising state OFF ... Normal running state	● This is displayed even when no ASCD is mounted.
ASCD OD cut signal	ASCD-OD CUT [ON/OFF]	X	—	● Status of ASCD OD release signal is displayed. ON ... OD released OFF ... OD not released	● This is displayed even when no ASCD is mounted.
Kickdown switch	KICKDOWN SW [ON/OFF]	X	—	● ON/OFF status, computed from signal of kickdown SW, is displayed.	● This is displayed even when no kickdown switch is equipped.
Closed throttle position switch	CLOSED THL/SW [ON/OFF]	X	—	● ON/OFF status, computed from signal of closed throttle position SW, is displayed.	
Wide open throttle position switch	W/O THRL/P-SW [ON/OFF]	X	—	● ON/OFF status, computed from signal of wide open throttle position SW, is displayed.	
Gear position	GEAR	—	X	● Gear position data used for computation by TCM, is displayed.	

ON BOARD DIAGNOSTIC SYSTEM DESCRIPTION

CONSULT (Cont'd)

Item	Display	Monitor item		Description	Remarks
		ECU input signals	Main signals		
Selector lever position	SLCT LVR POSI	—	X	● Selector lever position data, used for computation by TCM, is displayed.	● A specific value used for control is displayed if fail-safe is activated due to error.
Vehicle speed	VEHICLE SPEED [km/h] or [mph]	—	X	● Vehicle speed data, used for computation by TCM, is displayed.	
Throttle position	THROTTLE POSI [8]	—	X	● Throttle position data, used for computation by TCM, is displayed.	● A specific value used for control is displayed if fail-safe is activated due to error.
Line pressure duty	LINE PRES DTY [%]	—	X	● Control value of line pressure solenoid valve, computed by TCM from each input signal, is displayed.	
Torque converter clutch solenoid valve duty	TCC S/V DUTY [%]	—	X	● Control value of torque converter clutch solenoid valve, computed by TCM from each input signal, is displayed.	
Shift solenoid valve A	SHIFT S/V A [ON/OFF]	—	X	● Control value of shift solenoid valve A, computed by TCM from each input signal, is displayed.	Control value of solenoid is displayed even if solenoid circuit is disconnected. The "OFF" signal is displayed if solenoid circuit is shorted.
Shift solenoid valve B	SHIFT S/V B [ON/OFF]	—	X	● Control value of shift solenoid valve B, computed by TCM from each input signal, is displayed.	
Overrun clutch solenoid valve	OVERRUN/C S/V [ON/OFF]	—	X	● Control value of overrun clutch solenoid valve computed by TCM from each input signal is displayed.	
Self-diagnosis display lamp (O/D OFF indicator lamp)	SELF-D DP LMP [ON/OFF]	—	X	● Control status of O/D OFF indicator lamp is displayed.	

X: Applicable
—: Not applicable

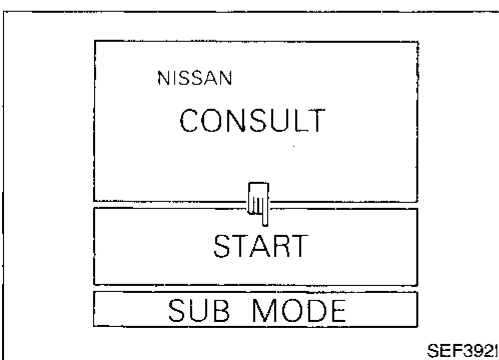
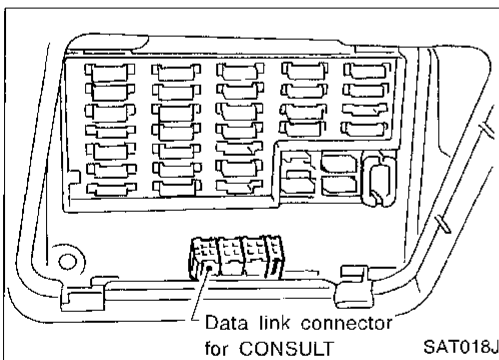

DTC WORK SUPPORT MODE WITH CONSULT

CONSULT setting procedure

1. Turn ignition switch "OFF".
2. Connect CONSULT to Data link connector for CONSULT. Data link connector for CONSULT is located in left side dash panel.
3. Turn ignition switch "ON".
4. Touch "START".

ON BOARD DIAGNOSTIC SYSTEM DESCRIPTION

CONSULT (Cont'd)

5. Touch "A/T".

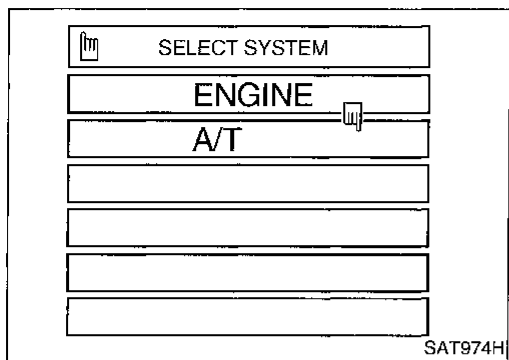

6. Touch "DTC WORK SUPPORT".

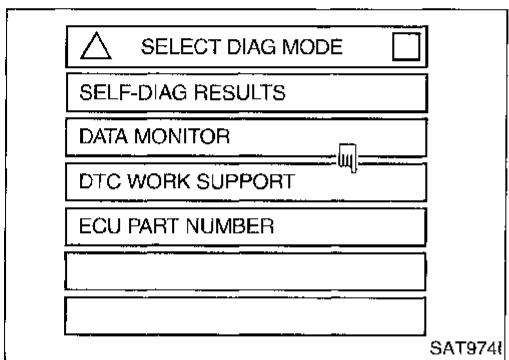

7. Touch select item menu (1ST, 2ND, etc.).

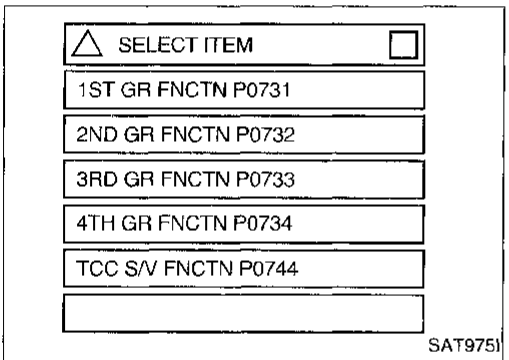

8. Touch "START".

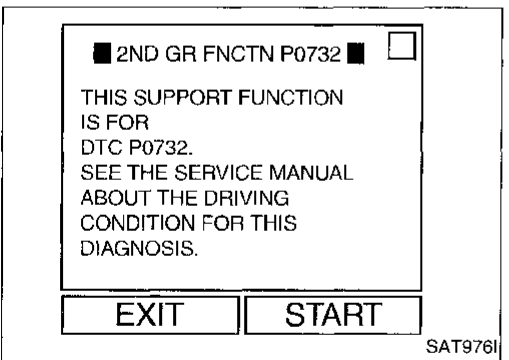

9. Perform driving test according to "DTC CONFIRMATION PROCEDURE" in "TROUBLE DIAGNOSIS FOR DTC".

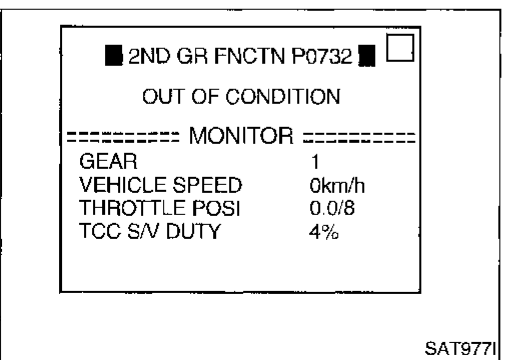

ON BOARD DIAGNOSTIC SYSTEM DESCRIPTION

CONSULT (Cont'd)

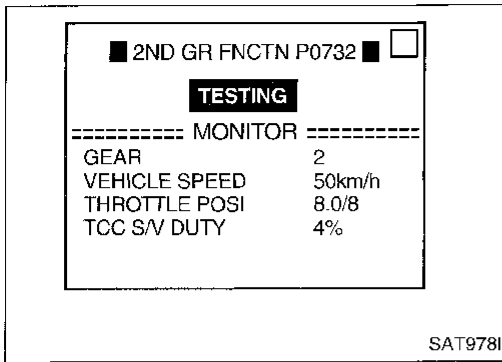

- When testing conditions are satisfied, CONSULT screen changes from "OUT OF CONDITION" to "TESTING".

GI

MA

EM

LC

EC

FE

CL

MT

AT

FA

FA

BR

ST

RS

BT

HA

EL

IDX

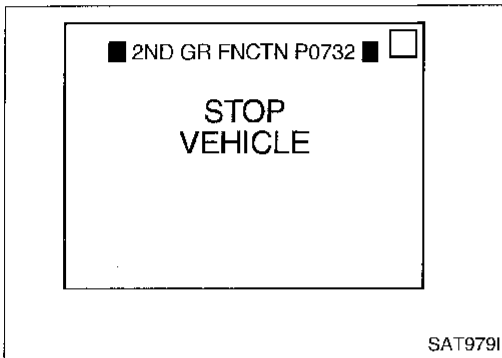

- Stop vehicle. If "NG" appears on the screen, malfunction may exist. Go to "DIAGNOSTIC PROCEDURE".

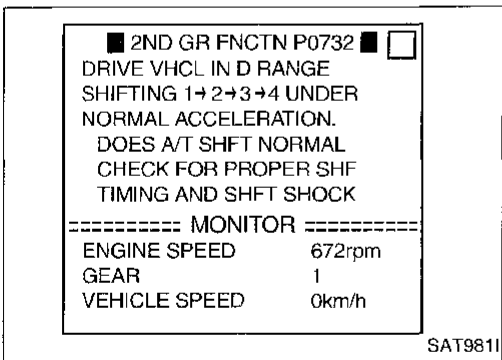
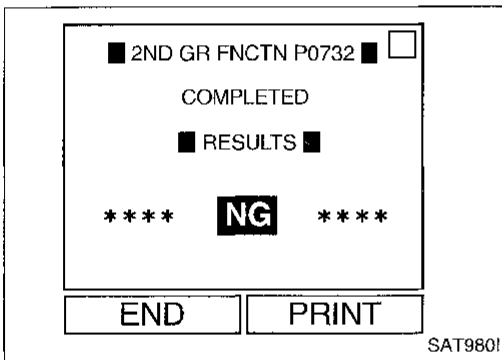

- Perform test drive to check gear shift feeling in accordance with instructions displayed.

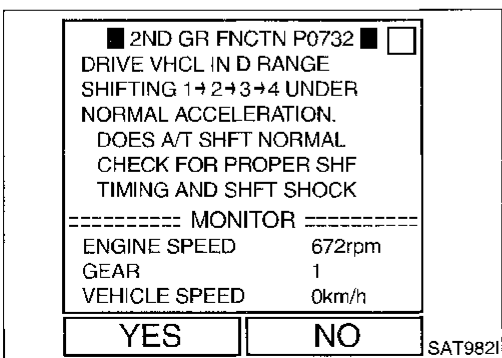

- Touch "YES" or "NO".

ON BOARD DIAGNOSTIC SYSTEM DESCRIPTION

CONSULT (Cont'd)

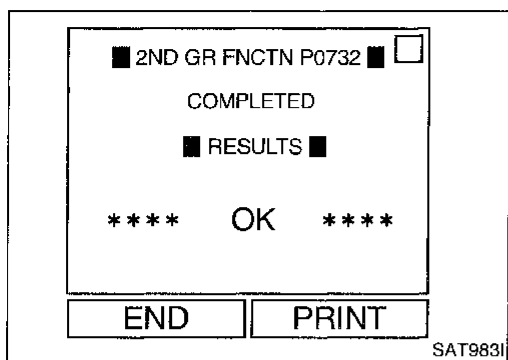

13. CONSULT procedure ended.

If "NG" appears on the screen, a malfunction may exist. Go to "DIAGNOSTIC PROCEDURE".

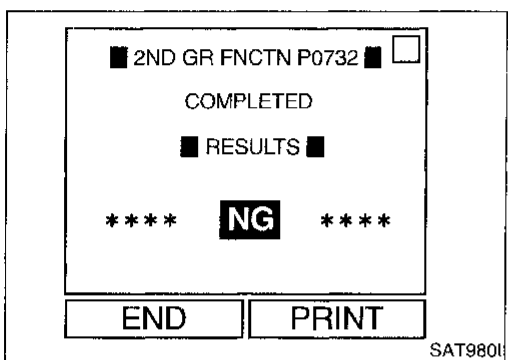

DTC WORK SUPPORT MODE

DTC work support item	Description	Check item
1ST GR FNCTN P0731	<p>Following items for "A/T 1st gear function (P0731)" can be confirmed.</p> <ul style="list-style-type: none"> ● Self-diagnosis status (whether the diagnosis is being conducted or not) ● Self-diagnosis result (OK or NG) 	<ul style="list-style-type: none"> ● Shift solenoid valve A ● Shift solenoid valve B ● Each clutch ● Hydraulic control circuit
2ND GR FNCTN P0732	<p>Following items for "A/T 2nd gear function (P0732)" can be confirmed.</p> <ul style="list-style-type: none"> ● Self-diagnosis status (whether the diagnosis is being conducted or not) ● Self-diagnosis result (OK or NG) 	<ul style="list-style-type: none"> ● Shift solenoid valve B ● Each clutch ● Hydraulic control circuit
3RD GR FNCTN P0733	<p>Following items for "A/T 3rd gear function (P0733)" can be confirmed.</p> <ul style="list-style-type: none"> ● Self-diagnosis status (whether the diagnosis is being conducted or not) ● Self-diagnosis result (OK or NG) 	<ul style="list-style-type: none"> ● Shift solenoid valve A ● Each clutch ● Hydraulic control circuit
4TH GR FNCTN P0734	<p>Following items for "A/T 4th gear function (P0734)" can be confirmed.</p> <ul style="list-style-type: none"> ● Self-diagnosis status (whether the diagnosis is being conducted or not) ● Self-diagnosis result (OK or NG) 	<ul style="list-style-type: none"> ● Shift solenoid valve A ● Shift solenoid valve B ● Overrun clutch solenoid valve ● Line pressure solenoid valve ● Each clutch ● Hydraulic control circuit
TCC S/V FNCTN P0744	<p>Following items for "A/T TCC S/V function (lock-up)" can be confirmed.</p> <ul style="list-style-type: none"> ● Self-diagnosis status (whether the diagnosis is being conducted or not) ● Self-diagnosis result (OK or NG) 	<ul style="list-style-type: none"> ● Torque converter clutch solenoid valve ● Each clutch ● Hydraulic control circuit

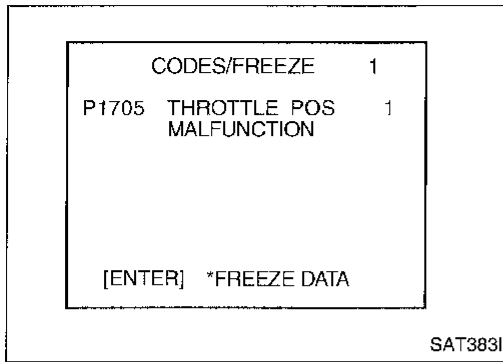

Diagnostic Procedure Without CONSULT



OBD-II SELF-DIAGNOSTIC PROCEDURE (With GST)

Refer to EC section ["Generic Scan Tool (GST)", "ON BOARD DIAGNOSTIC SYSTEM DESCRIPTION"].



OBD-II SELF-DIAGNOSTIC PROCEDURE (No Tools)

Refer to EC section ["Malfunction Indicator Lamp (MIL)", "ON BOARD DIAGNOSTIC SYSTEM DESCRIPTION"].

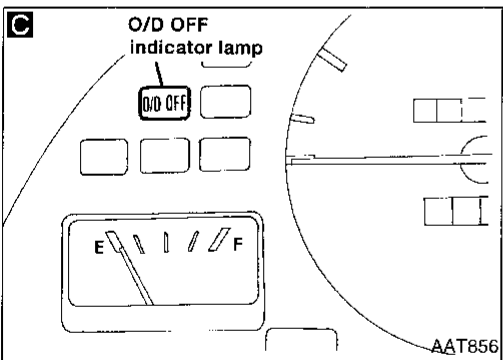
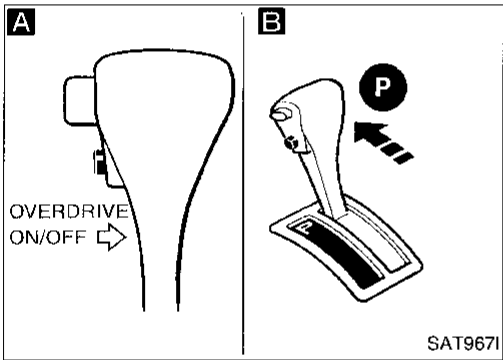

TCM SELF-DIAGNOSTIC PROCEDURE (No Tools)

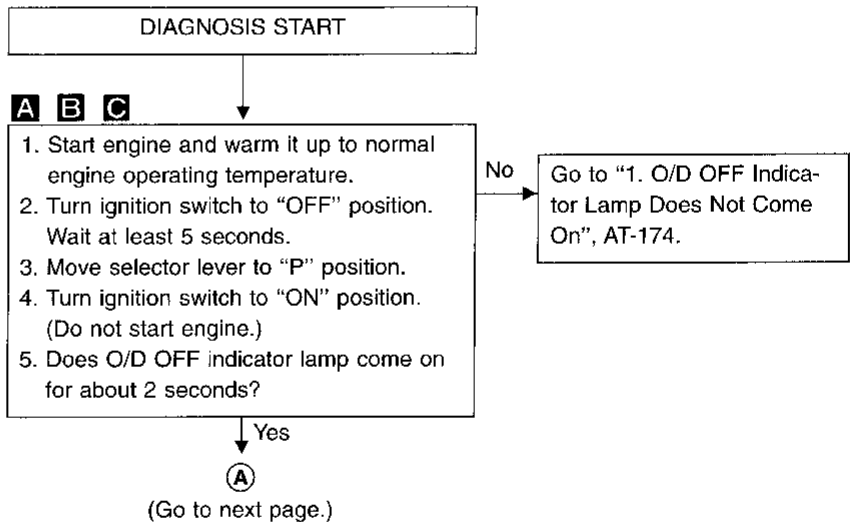

GI
MA
EM
LC
EC
FE
CL
MT
AT
FA
RA
BR
ST
RS
BT
HA
EL
IDX

ON BOARD DIAGNOSTIC SYSTEM DESCRIPTION

Diagnostic Procedure Without CONSULT (Cont'd)

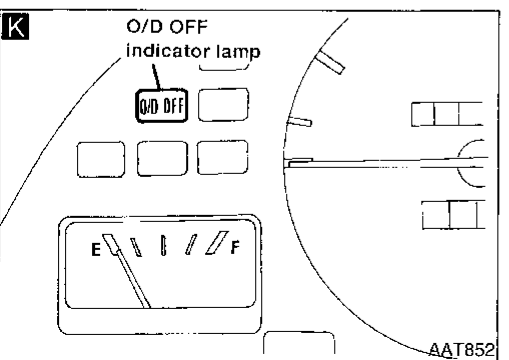
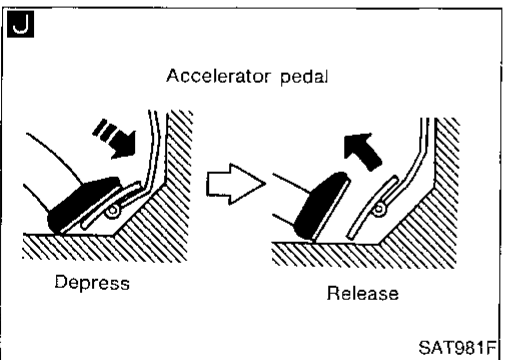
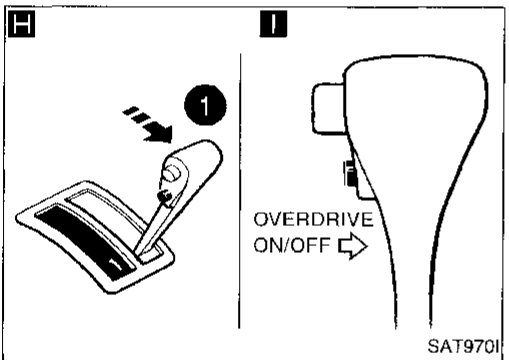
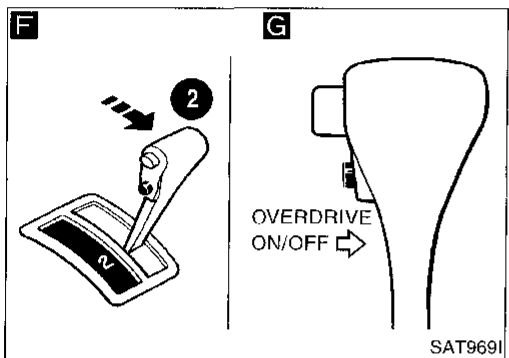
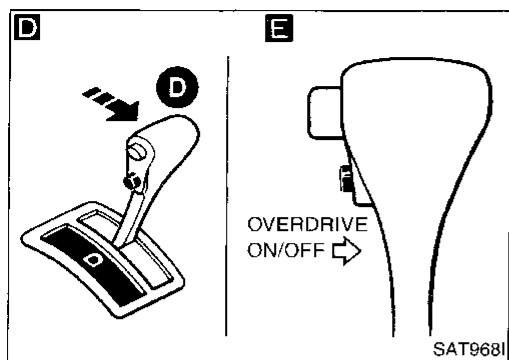

D E

1. Turn ignition switch to "OFF" position.
2. Turn ignition switch to "ACC" position.
3. Move selector lever to "D" position.
4. Turn ignition switch to "ON" position.
(Do not start engine.)
5. Depress and hold overdrive control switch in "OFF" position until next step is completed.
6. Turn ignition switch to "OFF" position.
7. Turn ignition switch to "ON" position
(Do not start engine.)

- Wait more than 2 seconds after ignition switch "ON".

F G

1. Move selector lever to "2" position.
2. Depress and hold overdrive control switch in "ON" position until next step is completed.

H I

1. Move selector lever to "1" position.
2. Cycle overdrive control switch from "OFF" to "ON" position, depress and hold in "OFF" position until next step is completed.

J

Depress accelerator pedal fully and release it.

K

Check O/D OFF indicator lamp.
Refer to JUDGEMENT OF SELF-DIAGNOSIS CODE, AT-45.

DIAGNOSIS END

ON BOARD DIAGNOSTIC SYSTEM DESCRIPTION

Diagnostic Procedure Without CONSULT (Cont'd)

JUDGEMENT OF SELF-DIAGNOSIS CODE

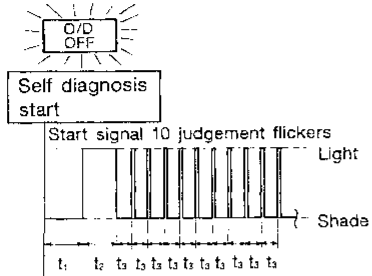
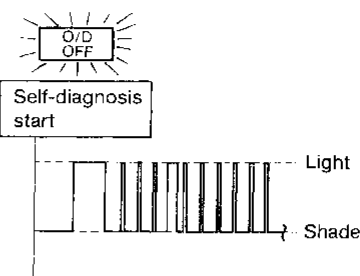
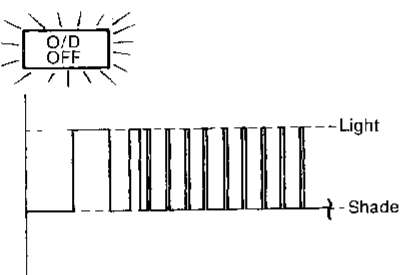
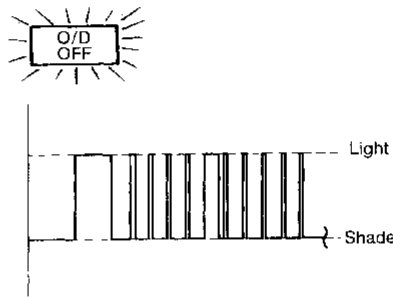
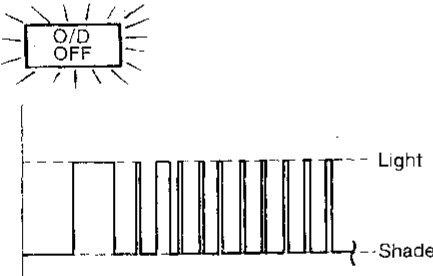
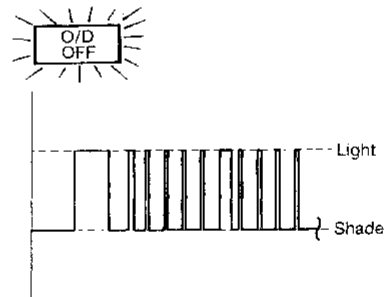
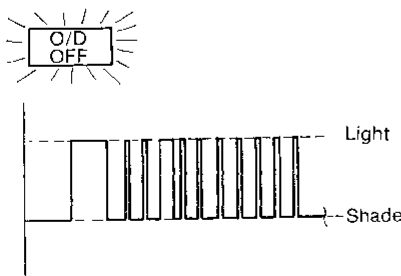
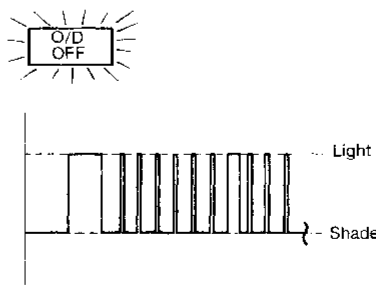
O/D OFF indicator lamp:	
<p>All judgement flickers are the same.</p>  <p style="text-align: right;">SAT436F</p>	<p>4th judgement flicker is longer than others.</p>  <p style="text-align: right;">SAT443F</p> <p>Shift solenoid valve A circuit is short-circuited or disconnected. Go to SHIFT SOLENOID VALVE A (DTC: 1108), AT-140.</p>
<p>All circuits that can be confirmed by self-diagnosis are OK.</p> <p>1st judgement flicker is longer than others.</p>  <p style="text-align: right;">SAT437F</p> <p>Revolution sensor circuit is short-circuited or disconnected. Go to VEHICLE SPEED SENSOR-A/T (REVOLUTION SENSOR) (DTC: 1102), AT-86.</p>	<p>5th judgement flicker is longer than others.</p>  <p style="text-align: right;">SAT445F</p> <p>Shift solenoid valve B circuit is short-circuited or disconnected. Go to SHIFT SOLENOID VALVE B (DTC: 1201), AT-145.</p>
<p>2nd judgement flicker is longer than others.</p>  <p style="text-align: right;">SAT439F</p> <p>Vehicle speed sensor circuit is short-circuited or disconnected. Go to VEHICLE SPEED SENSOR-MTR, AT-167.</p>	<p>6th judgement flicker is longer than others.</p>  <p style="text-align: right;">SAT447F</p> <p>Overrun clutch solenoid valve circuit is short-circuited or disconnected. Go to OVERRUN CLUTCH SOLENOID VALVE (DTC: 1203), AT-157.</p>
<p>3rd judgement flicker is longer than others.</p>  <p style="text-align: right;">SAT441F</p> <p>Throttle position sensor circuit is short-circuited or disconnected. Go to THROTTLE POSITION SENSOR (DTC: 1206), AT-150.</p>	<p>7th judgement flicker is longer than others.</p>  <p style="text-align: right;">SAT449F</p> <p>Torque converter clutch solenoid valve circuit is short-circuited or disconnected. Go to TORQUE CONVERTER CLUTCH SOLENOID VALVE (DTC: 1204), AT-122.</p>

$t_1 = 2.5$ seconds $t_2 = 2.0$ seconds $t_3 = 1.0$ second

ON BOARD DIAGNOSTIC SYSTEM DESCRIPTION

Diagnostic Procedure Without CONSULT (Cont'd)

O/D OFF indicator lamp:

8th judgement flicker is longer than others.

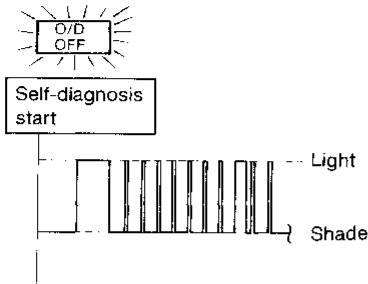

SAT451F

A/T fluid temperature sensor is disconnected or TCM power source circuit is damaged.
 ➔ Go to **A/T FLUID TEMPERATURE SENSOR AND TCM POWER SOURCE, AT-162.**

Flickers as shown below.

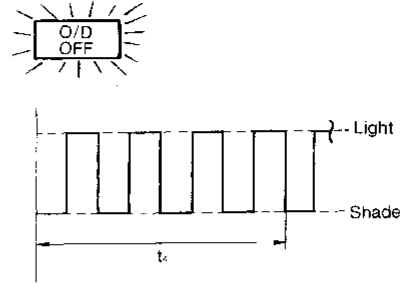

SAT457F

Battery power is low.
 Battery has been disconnected for a long time.
 Battery is connected conversely.
 (When reconnecting TCM connectors. — This is not a problem.)

9th judgement flicker is longer than others.

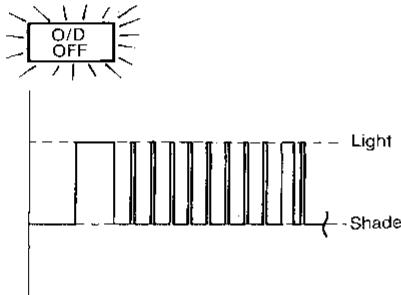

SAT453F

Engine speed signal circuit is short-circuited or disconnected.
 ➔ Go to **ENGINE SPEED SIGNAL (DTC: 1207), AT-90.**

Does not come on.

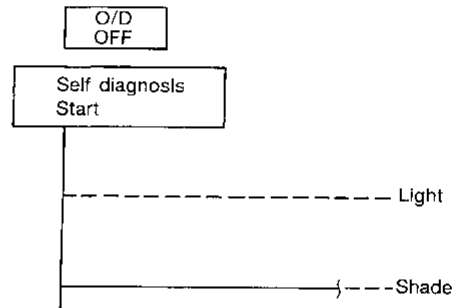

SAT414G

Inhibitor switch, overdrive control switch or throttle position switch circuit is disconnected or TCM is damaged.
 ➔ Go to **INHIBITOR, OVERDRIVE CONTROL AND THROTTLE POSITION SWITCHES, AT-189.**

10th judgement flicker is longer than others.

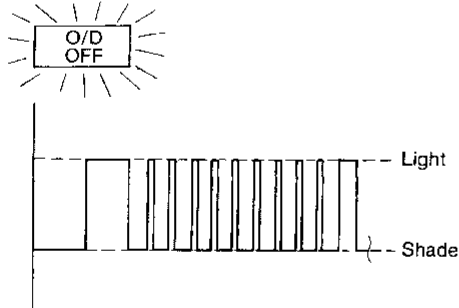

SAT455F

Line pressure solenoid valve circuit is short-circuited or disconnected.
 ➔ Go to **LINE PRESSURE SOLENOID VALVE (DTC: 1205), AT-135.**

$t_4 = 1.0$ second

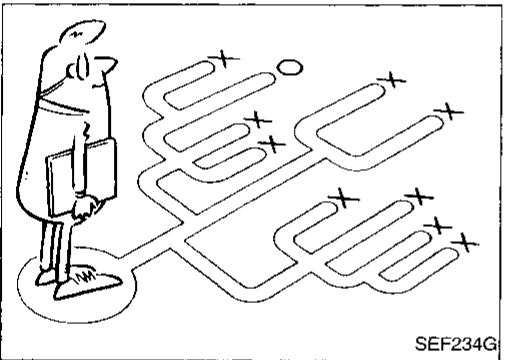
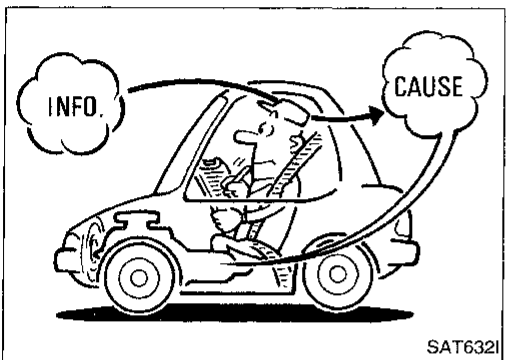
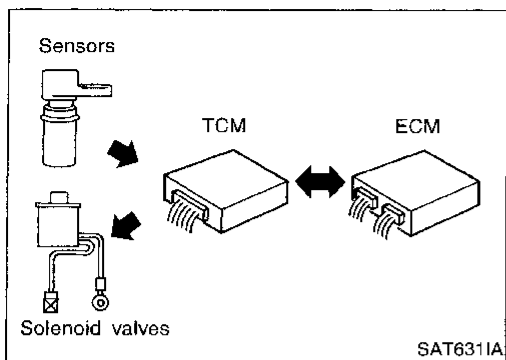

Introduction

The TCM receives a signal from the vehicle speed sensor, throttle position sensor or inhibitor switch and provides shift control or lock-up control via A/T solenoid valves.

The TCM also communicates with the ECM by means of a signal sent from sensing elements used with the OBD-related parts of the A/T system for malfunction-diagnostic purposes. The TCM is capable of diagnosing malfunctioning parts while the ECM can store malfunctions in its memory.

Input and output signals must always be correct and stable in the operation of the A/T system. The A/T system must be in good operating condition and be free of valve seizure, solenoid valve malfunction, etc.

It is much more difficult to diagnose a problem that occurs intermittently rather than continuously. Most intermittent problems are caused by poor electric connections or improper wiring. In this case, careful checking of suspected circuits may help prevent the replacement of good parts.

A visual check only may not find the cause of the problems. A road test with CONSULT (or GST) or a circuit tester connected should be performed. Follow the "Work Flow". Refer to AT-51. Before undertaking actual checks, take a few minutes to talk with a customer who approaches with a driveability complaint. The customer can supply good information about such problems, especially intermittent ones. Find out what symptoms are present and under what conditions they occur. A "Diagnostic Worksheet" like the example (AT-48) should be used.

Start your diagnosis by looking for "conventional" problems first. This will help troubleshoot driveability problems on an electronically controlled engine vehicle.

Also check related Service bulletins for information.

CI
MA
EM
LG
EC
FE
CL
MT
AT
FA
RA
BR
ST
RS
BT
HA
EL
DX

TROUBLE DIAGNOSIS — Introduction

Diagnostic Worksheet (Cont'd)

DIAGNOSTIC WORKSHEET

1.	<input type="checkbox"/> Read the Fail-safe and listen to customer complaints.	AT-5	GI
2.	<input type="checkbox"/> CHECK A/T FLUID <input type="checkbox"/> Leakage (Follow specified procedure) <input type="checkbox"/> Fluid condition <input type="checkbox"/> Fluid level	AT-52	MA
3.	<input type="checkbox"/> Perform STALL TEST and PRESSURE TEST. <input type="checkbox"/> Stall test — Mark possible damaged components/others. <div style="display: flex; justify-content: space-between;"> <div style="width: 48%;"> <input type="checkbox"/> Torque converter one-way clutch <input type="checkbox"/> Reverse clutch <input type="checkbox"/> Forward clutch <input type="checkbox"/> Overrun clutch <input type="checkbox"/> Forward one-way clutch </div> <div style="width: 48%;"> <input type="checkbox"/> Low & reverse brake <input type="checkbox"/> Low one-way clutch <input type="checkbox"/> Engine <input type="checkbox"/> Line pressure is low <input type="checkbox"/> Clutches and brakes except high clutch and brake band are OK </div> </div> <input type="checkbox"/> Pressure test — Suspected parts:	AT-52, 55	EM LC EC FE
4.	<input type="checkbox"/> Perform all ROAD TEST and mark required procedures. 4-1. Check before engine is started <input type="checkbox"/> SELF-DIAGNOSTIC PROCEDURE — Mark detected items. <input type="checkbox"/> Inhibitor switch, AT-76. <input type="checkbox"/> A/T fluid temperature sensor, AT-81. <input type="checkbox"/> Vehicle speed sensor-A/T (Revolution sensor), AT-86. <input type="checkbox"/> Engine speed signal, AT-90. <input type="checkbox"/> Torque converter clutch solenoid valve, AT-122. <input type="checkbox"/> Line pressure solenoid valve, AT-135. <input type="checkbox"/> Shift solenoid valve A, AT-140. <input type="checkbox"/> Shift solenoid valve B, AT-145. <input type="checkbox"/> Throttle position sensor, AT-150. <input type="checkbox"/> Overrun clutch solenoid valve, AT-157. <input type="checkbox"/> Inhibitor, overdrive control and throttle position switches, AT-189. <input type="checkbox"/> A/T fluid temperature sensor and TCM power source, AT-162. <input type="checkbox"/> Vehicle speed sensor-MTR, AT-167. <input type="checkbox"/> Battery <input type="checkbox"/> Others	AT-56 AT-57	CL MT
	4-2. Check at idle <input type="checkbox"/> 1. O/D OFF Indicator Lamp Does Not Come On, AT-174. <input type="checkbox"/> 2. Engine Cannot Be Started In "P" And "N" Position, AT-175. <input type="checkbox"/> 3. In "P" Position, Vehicle Moves Forward Or Backward When Pushed, AT-175. <input type="checkbox"/> 4. In "N" Position, Vehicle Moves, AT-176. <input type="checkbox"/> 5. Large Shock. "N" → "R" Position, AT-177. <input type="checkbox"/> 6. Vehicle Does Not Creep Backward In "R" Position, AT-178. <input type="checkbox"/> 7. Vehicle Does Not Creep Forward In "D", "2" Or "1" Position, AT-179.	AT-58	AT FA RA BR
	4-3. Cruise test Part-1 <input type="checkbox"/> 8. Vehicle Cannot Be Started From D ₁ , AT-180. <input type="checkbox"/> 9. A/T Does Not Shift: D ₁ → D ₂ Or Does Not Kickdown: D ₄ → D ₂ , AT-181. <input type="checkbox"/> 10. A/T Does Not Shift: D ₂ → D ₃ , AT-182. <input type="checkbox"/> 11. A/T Does Not Shift: D ₃ → D ₄ , AT-183. <input type="checkbox"/> 12. A/T Does Not Perform Lock-up, AT-184. <input type="checkbox"/> 13. A/T Does Not Hold Lock-up Condition, AT-185. <input type="checkbox"/> 14. Lock-up Is Not Released, AT-185. <input type="checkbox"/> 15. Engine Speed Does Not Return To Idle (Light Braking D ₄ → D ₃), AT-186.	AT-60, AT-63	ST RS BT HA EL IDX

TROUBLE DIAGNOSIS — Introduction

Diagnostic Worksheet (Cont'd)

4.	<p>Part-2</p> <ul style="list-style-type: none"> <input type="checkbox"/> 16. Vehicle Does Not Start From D₁, AT-187. <input type="checkbox"/> 9. A/T Does Not Shift: D₁ → D₂ Or Does Not Kickdown: D₄ → D₂, AT-181. <input type="checkbox"/> 10. A/T Does Not Shift: D₂ → D₃, AT-182. <input type="checkbox"/> 11. A/T Does Not Shift: D₃ → D₄, AT-183. <p>Part-3</p> <ul style="list-style-type: none"> <input type="checkbox"/> 17. A/T Does Not Shift: D₄ → D₃ When Overdrive Control Switch "ON" → "OFF", AT-187 <input type="checkbox"/> 15. Engine Speed Does Not Return To Idle (Engine Brake In D₃), AT-186. <input type="checkbox"/> 18. A/T Does Not Shift: D₃ → 2₂, When Selector Lever "D" → "2" Position, AT-188. <input type="checkbox"/> 15. Engine Speed Does Not Return To Idle (Engine Brake In 2₂), AT-186. <input type="checkbox"/> 19. A/T Does Not Shift: 2₂ → 1₁, When Selector Lever "2" → "1" Position, AT-188. <input type="checkbox"/> 20. Vehicle Does Not Decelerate By Engine Brake, AT-189. <input type="checkbox"/> SELF-DIAGNOSTIC PROCEDURE — Mark detected items. <ul style="list-style-type: none"> <input type="checkbox"/> Inhibitor switch, AT-76. <input type="checkbox"/> A/T fluid temperature sensor, AT-81. <input type="checkbox"/> Vehicle speed sensor-A/T (Revolution sensor), AT-86. <input type="checkbox"/> Engine speed signal, AT-90. <input type="checkbox"/> Torque converter clutch solenoid valve, AT-122. <input type="checkbox"/> Line pressure solenoid valve, AT-135. <input type="checkbox"/> Shift solenoid valve A, AT-140. <input type="checkbox"/> Shift solenoid valve B, AT-145. <input type="checkbox"/> Throttle position sensor, AT-150. <input type="checkbox"/> Overrun clutch solenoid valve, AT-157. <input type="checkbox"/> Inhibitor, overdrive control and throttle position switches, AT-189. <input type="checkbox"/> A/T fluid temperature sensor and TCM power source, AT-162. <input type="checkbox"/> Vehicle speed sensor-MTR, AT-167. <input type="checkbox"/> Battery <input type="checkbox"/> Others 	AT-65
		AT-66
5.	<input type="checkbox"/> For self-diagnosis NG items, inspect each component. Repair or replace the damaged parts.	AT-37
6.	<input type="checkbox"/> Perform all ROAD TEST and re-mark required procedures.	AT-56
7.	<input type="checkbox"/> Perform DTC CONFIRMATION PROCEDURE for following MIL indicating items and check out NG items. Refer to EC section ["Emission-related Diagnostic Information", "ON BOARD DIAGNOSTIC SYSTEM DESCRIPTION"]. <ul style="list-style-type: none"> <input type="checkbox"/> DTC (P0731, 1103) A/T 1st gear function, AT-94. <input type="checkbox"/> DTC (P0732, 1104) A/T 2nd gear function, AT-101. <input type="checkbox"/> DTC (P0733, 1105) A/T 3rd gear function, AT-107. <input type="checkbox"/> DTC (P0734, 1106) A/T 4th gear function, AT-113. <input type="checkbox"/> DTC (P0744, 1107) A/T TCC S/V function (lock-up), AT-127. 	EC section
8.	<input type="checkbox"/> Perform the Diagnostic Procedures for all remaining items marked NG. Repair or replace the damaged parts. Refer to the Symptom Chart when you perform the procedures. (The chart also shows some other possible symptoms and the component inspection orders.)	AT-70, AT-67
9.	<input type="checkbox"/> Erase DTC from TCM and ECM memories.	AT-34

Work Flow

HOW TO PERFORM TROUBLE DIAGNOSES FOR QUICK AND ACCURATE REPAIR

A good understanding of the malfunction conditions can make troubleshooting faster and more accurate. In general, each customer feels differently about a problem. It is important to fully understand the symptoms or conditions for a customer complaint.

Make good use of the two sheets provided, "INFORMATION FROM CUSTOMER" (AT-48) and "DIAGNOSTIC WORKSHEET" (AT-49), to perform the best troubleshooting possible.

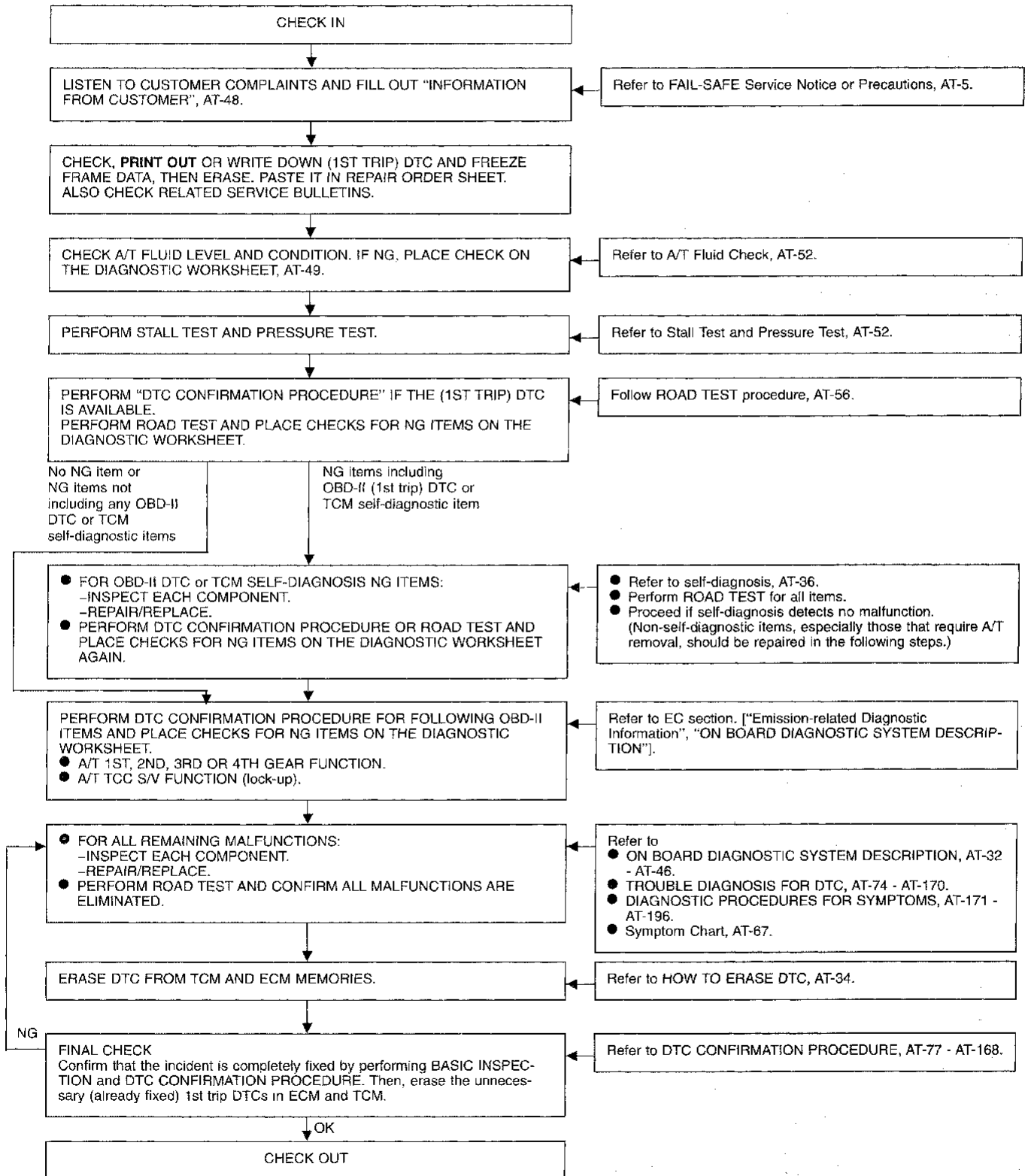

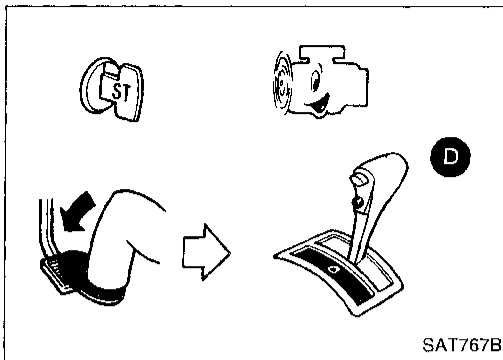

A/T Fluid Check

FLUID LEAKAGE CHECK

1. Clean area suspected of leaking. — for example, mating surface of converter housing and transmission case.
2. Start engine, apply foot brake, place selector lever in “D” position and wait a few minutes.
3. Stop engine.

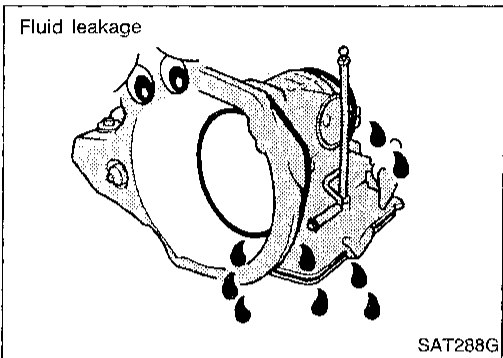

4. Check for fresh leakage.

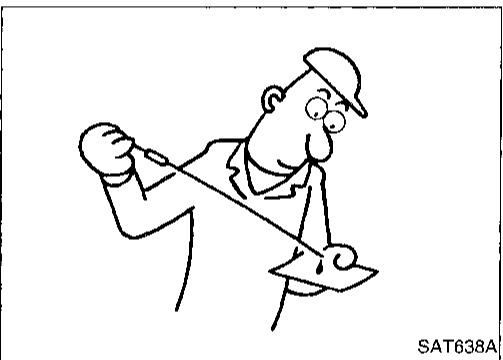

FLUID CONDITION CHECK

Fluid color	Suspected problem
Dark or black with burned odor	Wear of frictional material
Milky pink	Water contamination — Road water entering through filler tube or breather
Varnished fluid, light to dark brown and tacky	Oxidation — Over or under filling, — Overheating

FLUID LEVEL CHECK

Refer to MA section (“Checking A/T Fluid”, “CHASSIS AND BODY MAINTENANCE”).

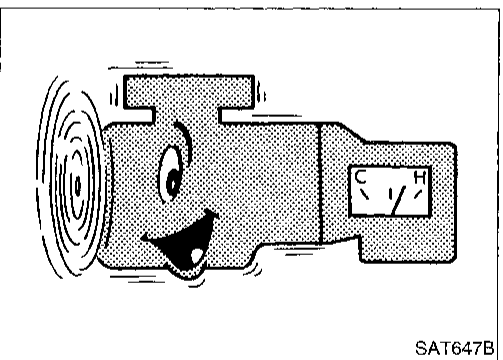

Stall Test

STALL TEST PROCEDURE

1. Check A/T and engine fluid levels. If necessary, add.
2. Drive vehicle for approx. 10 minutes or until engine oil and ATF reach operating temperature.

**ATF operating temperature:
50 - 80°C (122 - 176°F)**

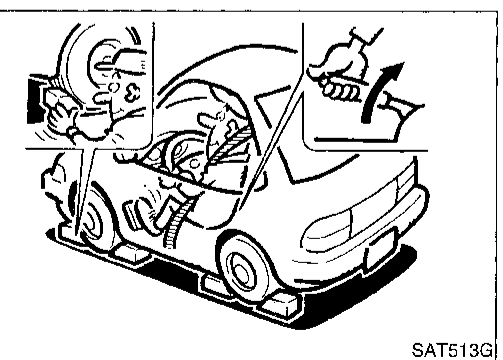

3. Set parking brake and block wheels.
 4. Install a tachometer where it can be seen by driver during test.
- It is good practice to mark the point of specified engine rpm on indicator.

Stall Test (Cont'd)

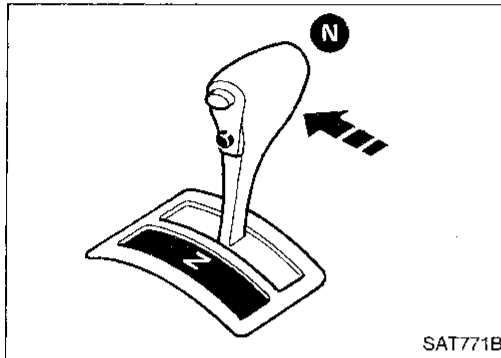
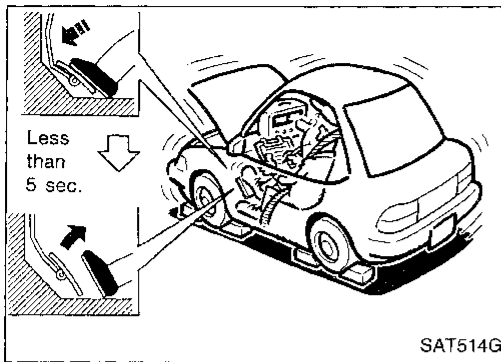

5. Start engine, apply foot brake, and place selector lever in D position.
6. Accelerate to wide-open throttle gradually while applying foot brake.
7. Quickly note the engine stall revolution and immediately release throttle.

- **During test, never hold throttle wide-open for more than 5 seconds.**

Stall revolution:

2,150 - 2,450 rpm

8. Move selector lever to "N" position.
9. Cool off ATF.

- **Run engine at idle for at least one minute.**

10. Repeat steps 5 through 9 with selector lever in "2", "1" and "R" positions.

JUDGEMENT OF STALL TEST

The test result and possible damaged components relating to each result are shown in the illustrations on next page.

In order to pinpoint the possible damaged components, follow the WORK FLOW shown in AT-51.

Note

Stall revolution is too high in "D", "2" or "1" position:

- Slippage occurs in 1st gear but not in 2nd and 3rd gears. Low one-way clutch slippage
- Slippage occurs in the following gears:
1st through 3rd gears in "D" position and engine brake functions with overdrive control switch set to "OFF".
1st and 2nd gears in "2" position and engine brake functions with accelerator pedal released (fully closed throttle). Forward clutch or forward one-way clutch slippage

Stall revolution is too high in R position:

- Engine brake does not function in "1" position. Low & reverse brake slippage
- Engine brake functions in "1" position. Reverse clutch slippage

Stall revolution within specifications:

- Vehicle does not achieve speed of more than 80 km/h (50 MPH). One-way clutch seizure in torque converter housing

CAUTION:

Be careful since automatic fluid temperature increases abnormally.

- Slippage occurs in 3rd and 4th gears in "D" position. High clutch slippage
- Slippage occurs in 2nd and 4th gear in "D" position. Brake band slippage
- Engine brake does not function in 2nd and 3rd gears in "D" position, 2nd gear in "2" position, and 1st gear in "1" position with overdrive control switch set to "OFF".

Stall revolution less than specifications:

- Poor acceleration during starts. One-way clutch seizure in torque converter

TROUBLE DIAGNOSIS — Basic Inspection

Stall Test (Cont'd)

Judgement of stall test

Selector lever position	Judgement		
D	H	O	L
2	H	O	L
1	H	O	L
R	O	H	L

O : Stall revolution is normal.
 H : Stall revolution is higher than specified.
 L : Stall revolution is lower than specified.

Damaged components

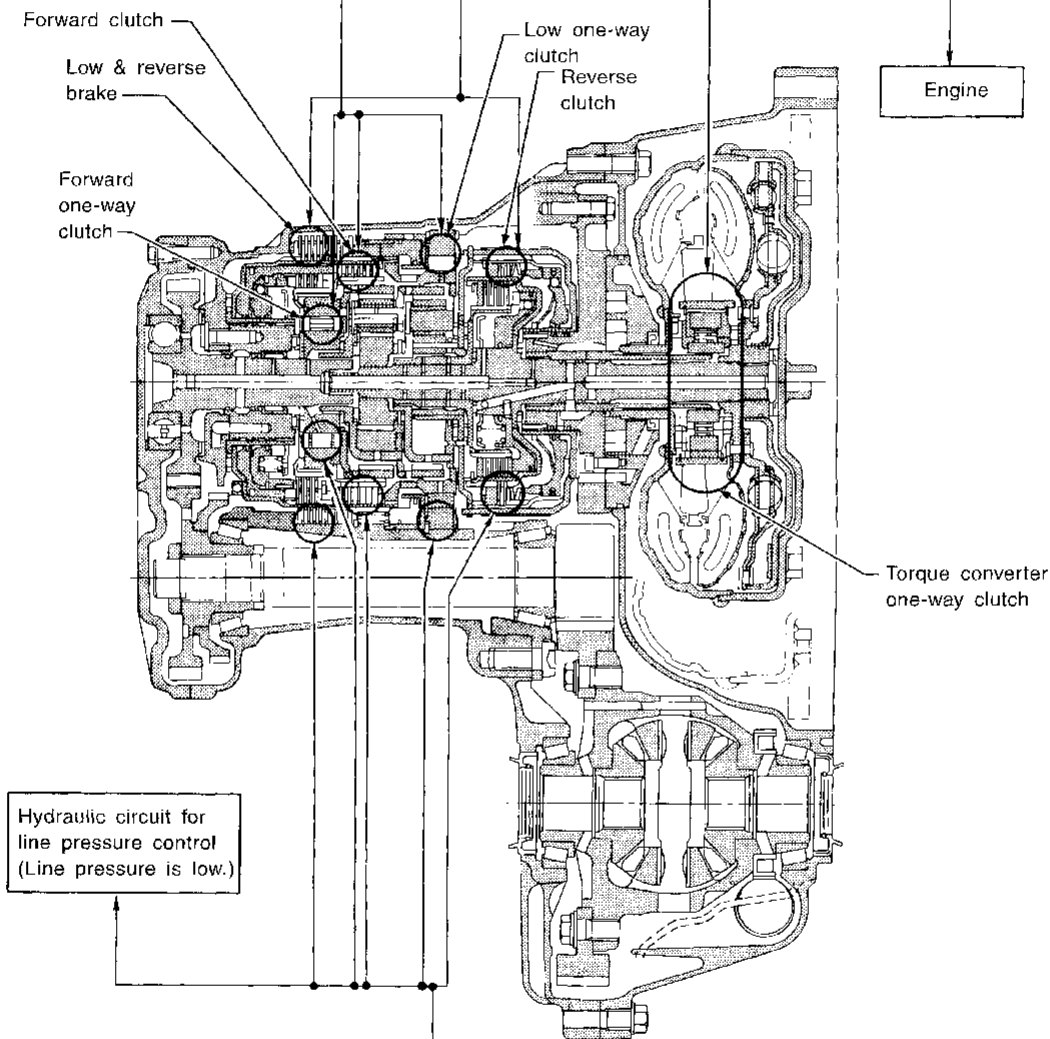

Hydraulic circuit for line pressure control
(Line pressure is low.)

Clutches and brakes except high clutch, brake band and overrun clutch are OK.
(Condition of high clutch, brake band and overrun clutch cannot be confirmed by stall test.)

D	H	O
2	H	O
1	H	O
R	H	O
Selector lever position	Judgement	

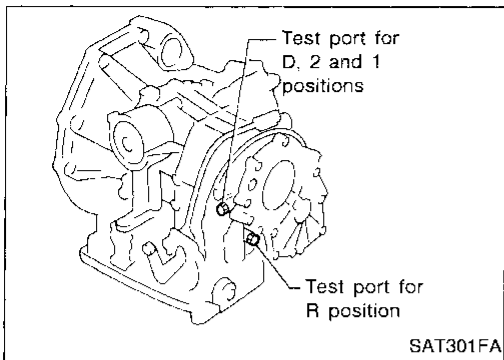

Pressure Test

PRESSURE TEST PORTS

Location of pressure test ports are shown in the illustration.

- **Always replace pressure plugs as they are self-sealing bolts.**

GI

MA

EM

LC

EC

FE

CL

MT

AT

FA

RA

BR

ST

RS

BT

HA

EL

IDX

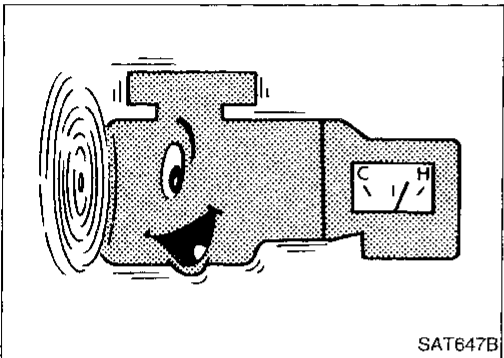

LINE PRESSURE TEST PROCEDURE

1. Check A/T and engine fluid levels. If necessary, add fluid.
2. Drive vehicle for approx. 10 minutes or until engine oil and ATF reach operating temperature.

ATF operating temperature:

50 - 80°C (122 - 176°F)

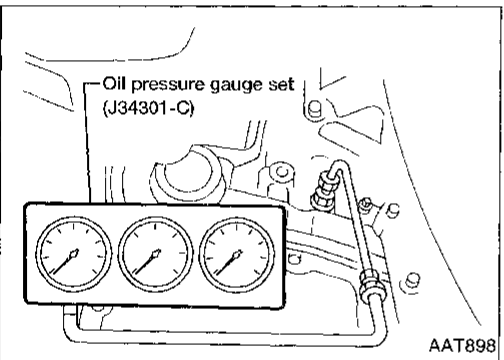

3. Install pressure gauge to corresponding line pressure port.

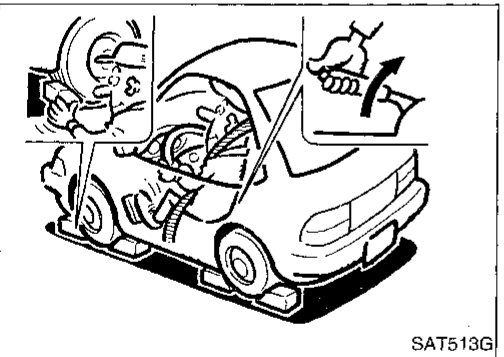

4. Set parking brake and block wheels.
 - **Continue to depress brake pedal fully while line pressure test is being performed at stall speed.**

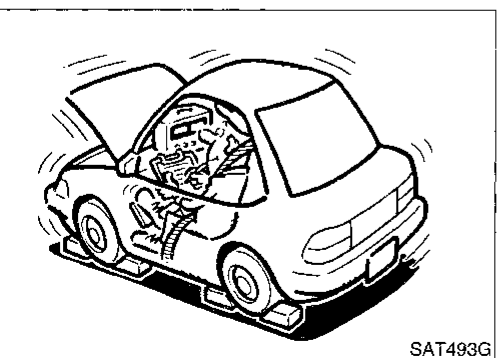

5. Start engine and measure line pressure at idle and stall speed.

- **When measuring line pressure at stall speed, follow the stall test procedure.**

Line pressure: Refer to SDS, AT-301.

TROUBLE DIAGNOSIS — Basic Inspection

Pressure Test (Cont'd)

JUDGEMENT OF LINE PRESSURE TEST

Judgement		Suspected parts
At idle	Line pressure is low in all positions.	<ul style="list-style-type: none"> ● Oil pump wear ● Control piston damage ● Pressure regulator valve or plug sticking ● Spring for pressure regulator valve damaged ● Fluid pressure leakage between oil strainer and pressure regulator valve ● Clogged strainer
	Line pressure is low in particular position.	<ul style="list-style-type: none"> ● Fluid pressure leakage between manual valve and particular clutch ● For example, line pressure is: <ul style="list-style-type: none"> – Low in "R" and "1" positions, but – Normal in "D" and "2" positions. Therefore, fluid leakage exists at or around low and reverse brake circuit. Refer to "CLUTCH AND BRAKE CHART", AT-23.
	Line pressure is high.	<ul style="list-style-type: none"> ● Maladjustment of throttle position sensor ● A/T fluid temperature sensor damaged ● Line pressure solenoid valve sticking ● Short circuit of line pressure solenoid valve circuit ● Pressure modifier valve sticking ● Pressure regulator valve or plug sticking ● Open in dropping resistor circuit
At stall speed	Line pressure is low.	<ul style="list-style-type: none"> ● Maladjustment of throttle position sensor ● Line pressure solenoid valve sticking ● Short circuit of line pressure solenoid valve circuit ● Pressure regulator valve or plug sticking ● Pressure modifier valve sticking ● Pilot valve sticking

ROAD TEST PROCEDURE

1. Check before engine is started.



2. Check at idle.



3. Cruise test.

SAT786A

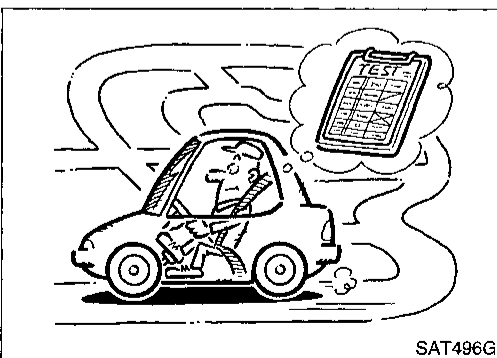

SAT496G

Road Test

DESCRIPTION

- The purpose of the test is to determine overall performance of A/T and analyze causes of problems.
- The road test consists of the following three parts:
 1. Check before engine is started
 2. Check at idle
 3. Cruise test
- Before road test, familiarize yourself with all test procedures and items to check.
- Conduct tests on all items until specified symptom is found. Troubleshoot items which check out No Good after road test. Refer to "ON BOARD DIAGNOSTIC SYSTEM DESCRIPTION" and "DIAGNOSTIC PROCEDURES FOR SYMPTOMS", AT-32 - AT-46 and AT-171 - AT-196.

TROUBLE DIAGNOSIS — Basic Inspection

Road Test (Cont'd)

1. CHECK BEFORE ENGINE IS STARTED

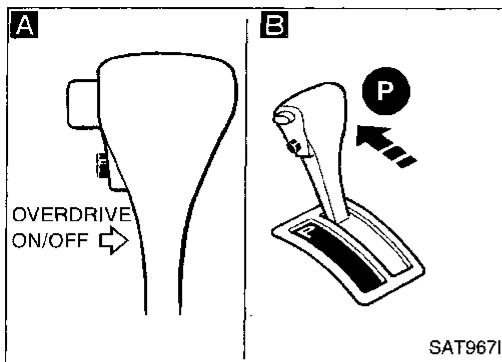

A B C

1. Park vehicle on flat surface.
2. Move selector lever to "P" position.
3. Turn ignition switch to "OFF" position. Wait at least 5 seconds.
4. Turn ignition switch to "ON" position. (Do not start engine.)
5. Does O/D OFF indicator lamp come on for about 2 seconds?

No → Stop ROAD TEST. Go to "1. O/D OFF Indicator Lamp Does Not Come On", AT-174.

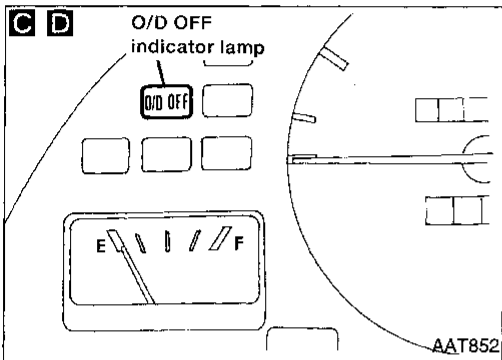

D

- Does O/D OFF indicator lamp flicker for about 8 seconds?

Yes → Perform self-diagnosis and check NG items on the DIAGNOSTIC WORKSHEET, AT-49. Refer to SELF-DIAGNOSIS PROCEDURE, AT-36.

- No →
1. Turn ignition switch to "OFF" position.
 2. Perform self-diagnosis and note NG items. Refer to SELF-DIAGNOSIS PROCEDURE, AT-36.
 3. Go to "2. CHECK AT IDLE", AT-58.

GI
MA
EM
LC
EC
FE
CL
MT
AT
FA
RA
BR
ST
RS
BT
HA
EL
IDX

TROUBLE DIAGNOSIS — Basic Inspection

Road Test (Cont'd)

2. CHECK AT IDLE

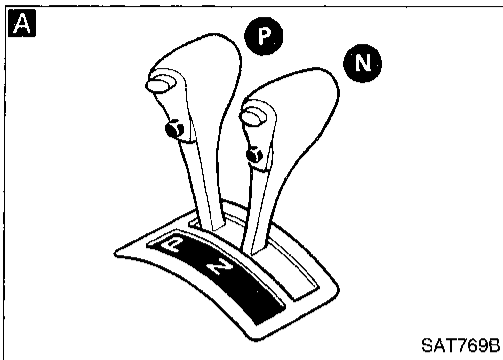

- A**
1. Park vehicle on flat surface.
 2. Move selector lever to "P" position.
 3. Turn ignition switch to "OFF" position.
 4. Turn ignition switch to "START" position.
 5. Is engine started?

No → Mark the box on the DIAGNOSTIC WORKSHEET. Go to "2. Engine Cannot Be Started In "P" and "N" Position", AT-175. Continue ROAD TEST.

Yes → Turn ignition switch to "ACC" position.

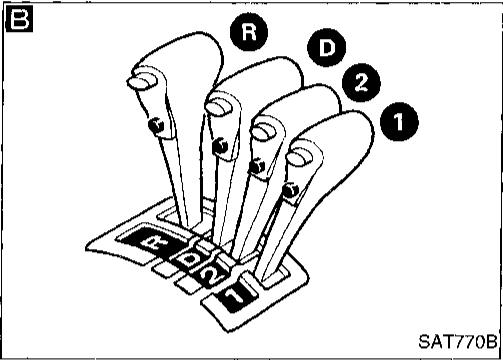

- B**
1. Move selector lever to "D", "1", "2" or "R" position.
 2. Turn ignition switch to "START" position.
 3. Is engine started?

Yes → Mark the box on the DIAGNOSTIC WORKSHEET. Go to "2. Engine Cannot Be Started In "P" and "N" Position", AT-175. Continue ROAD TEST.

- No →
- C**
1. Move selector lever to "P" position.
 2. Turn ignition switch to "OFF" position.
 3. Release parking brake.

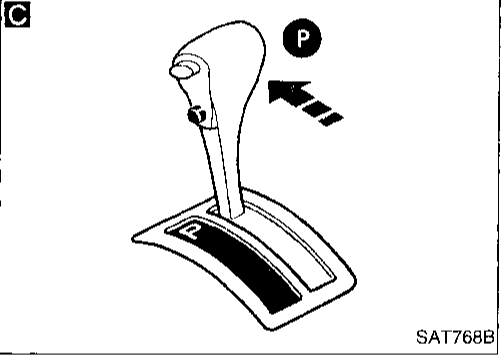

- D**
1. Push vehicle forward or backward.
 2. Does vehicle move when it is pushed forward or backward?
 3. Apply parking brake.

Yes → Mark the box on the DIAGNOSTIC WORKSHEET. Go to "3. In "P" Position, Vehicle Moves Forward Or Backward When Pushed", AT-175. Continue ROAD TEST.

- No →
- E**
1. Start engine.
 2. Move selector lever to "N" position.
 3. Release parking brake.
 4. Does vehicle move forward or backward?

Yes → Mark the box on the DIAGNOSTIC WORKSHEET. Go to "4. In "N" Position, Vehicle Moves", AT-176. Continue ROAD TEST.

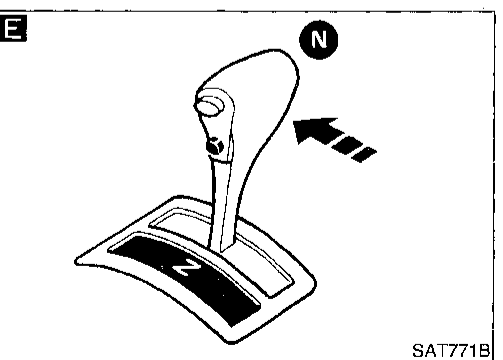
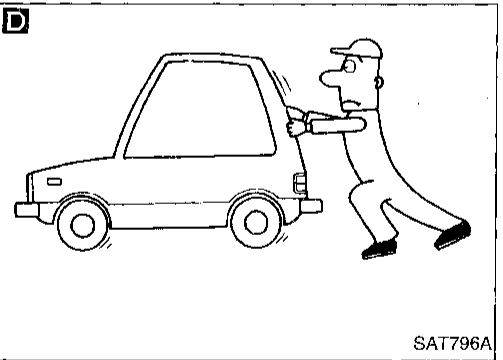

No → **A**
(Go to next page.)

TROUBLE DIAGNOSIS — Basic Inspection

Road Test (Cont'd)

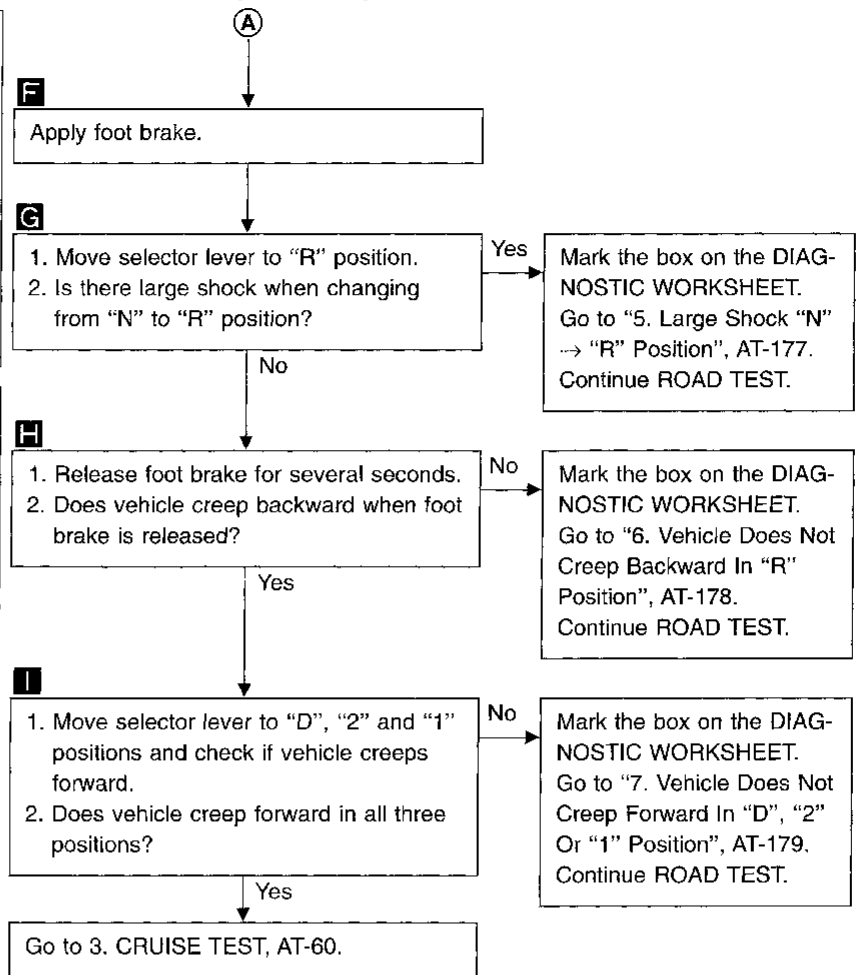
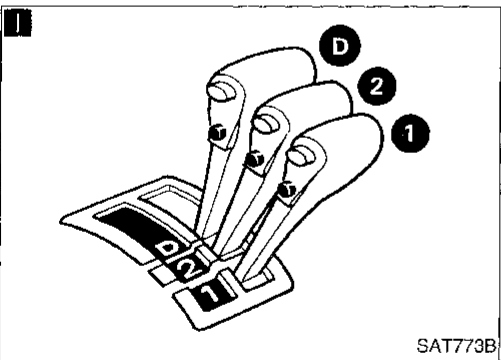
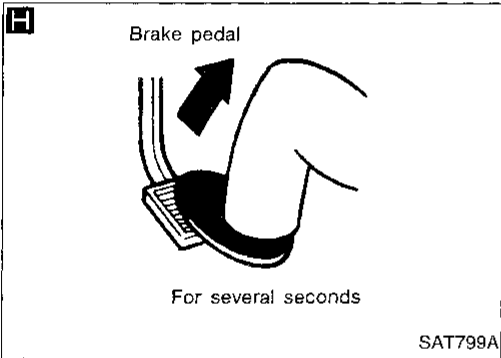
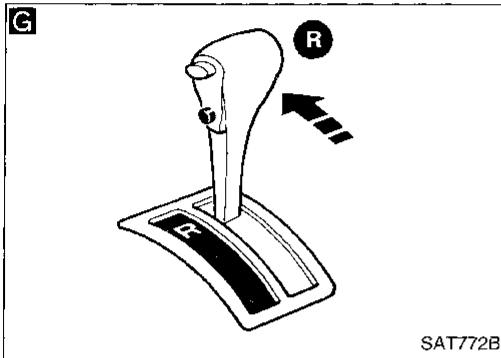
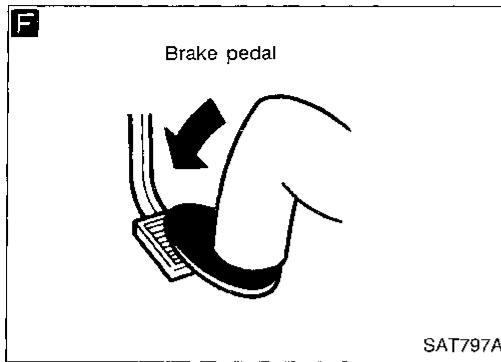

GI

MA

EM

LG

EC

FE

CL

WT

AT

FA

RA

BR

ST

RS

BT

HA

EL

IDX

TROUBLE DIAGNOSIS — Basic Inspection

Road Test (Cont'd)

3. CRUISE TEST

- Check all items listed in Parts 1 through 3.

With CONSULT

- Using CONSULT, conduct a cruise test and record the result.
- Print the result and ensure that shifts and lock-ups take place as per Shift Schedule.

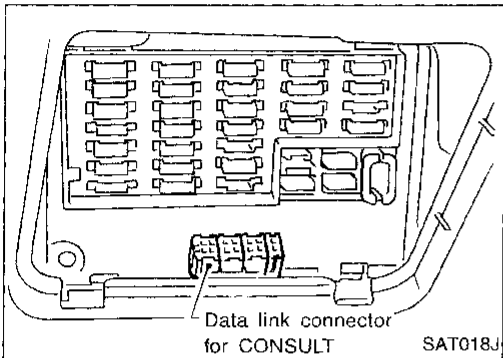
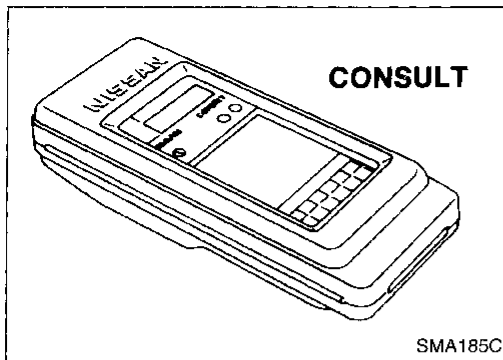

CONSULT setting procedure

1. Turn ignition switch "OFF".
2. Connect CONSULT to Data link connector for CONSULT. Data link connector for CONSULT is located in left side dash panel.

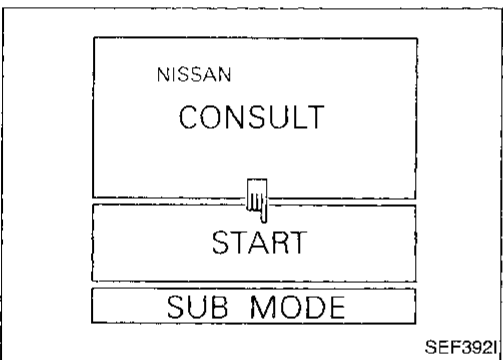

3. Turn ignition switch "ON".
4. Touch "START".

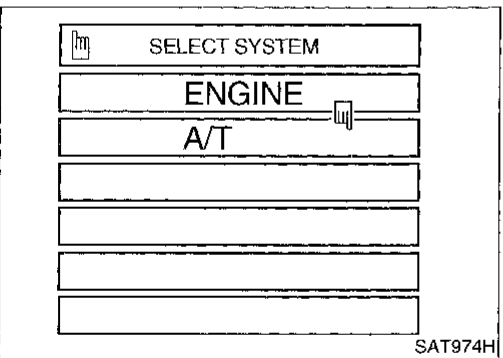

5. Touch "A/T".

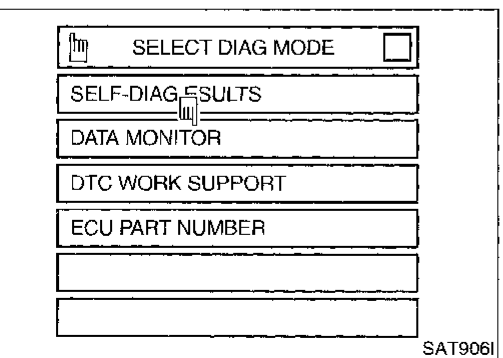

6. Touch "DATA MONITOR".

TROUBLE DIAGNOSIS — Basic Inspection

Road Test (Cont'd)

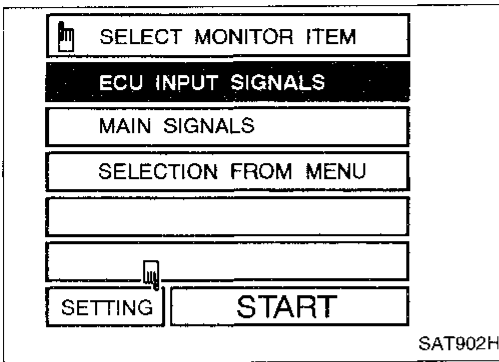

7. Touch "SETTING" to set recording condition.

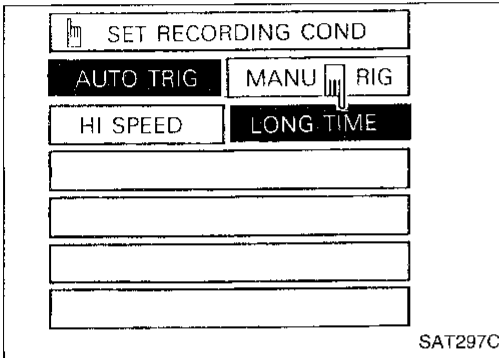

8. Touch "LONG TIME" and "ENTER" key.

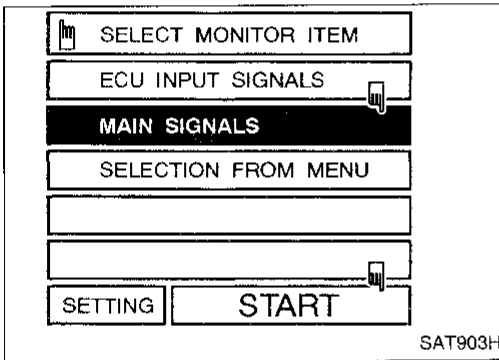

9. Go back to SELECT MONITOR ITEM and touch "MAIN SIGNALS".

10. Touch "START".

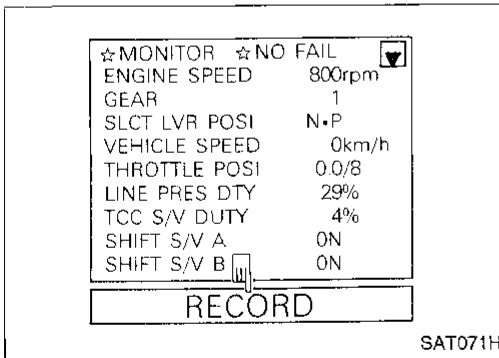

11. When performing cruise test, touch "RECORD".

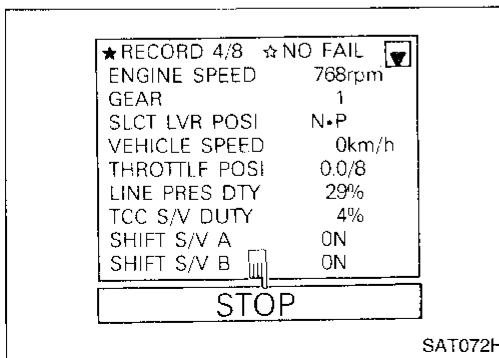

12. After finishing cruise test part 1, touch "STOP".

GI

MA

EM

LC

EC

FE

CL

MT

AT

FA

RA

BR

ST

RS

BT

HA

EL

IDX

TROUBLE DIAGNOSIS — Basic Inspection

Road Test (Cont'd)

13. Touch "DISPLAY".

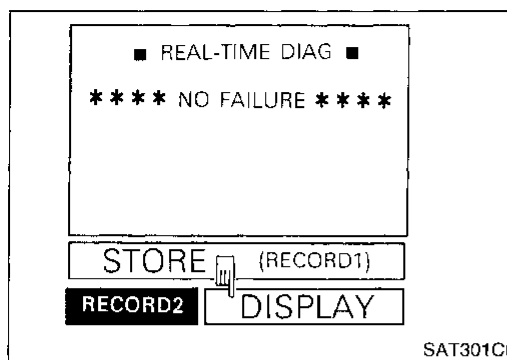

14. Touch "PRINT".

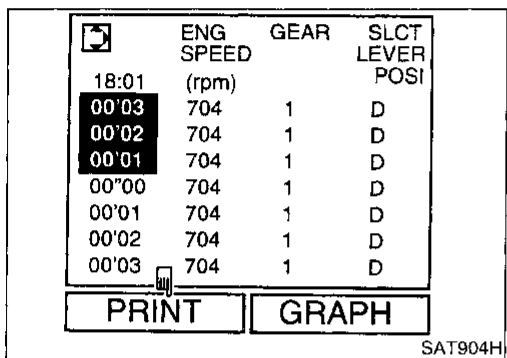

15. Touch "PRINT" again.

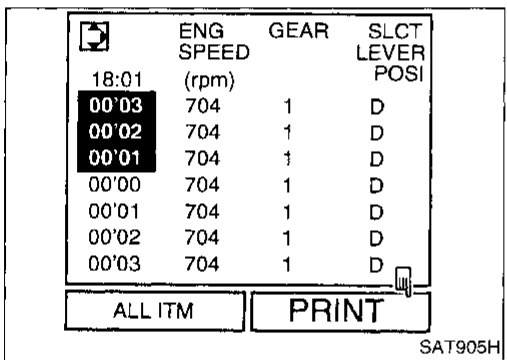

16. Check the monitor data printed out.

17. Continue cruise test part 2 and 3.

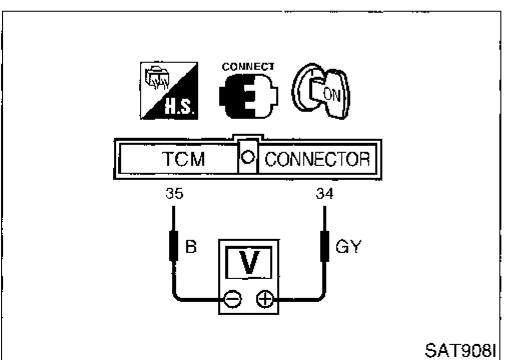
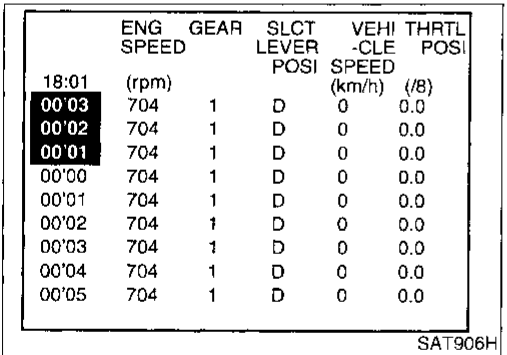

Without CONSULT

- Throttle position can be checked by voltage across terminals ③④ and ③⑤ of TCM.

Road Test (Cont'd)

CRUISE TEST — Part 1

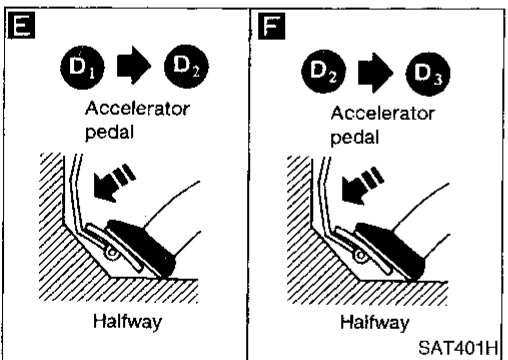
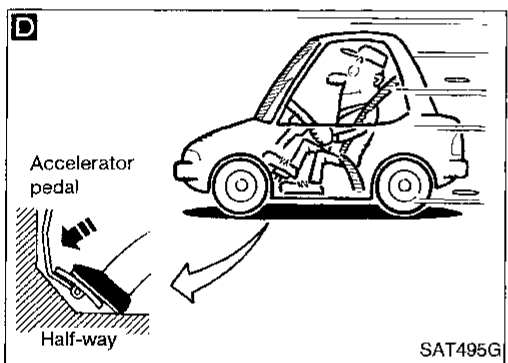
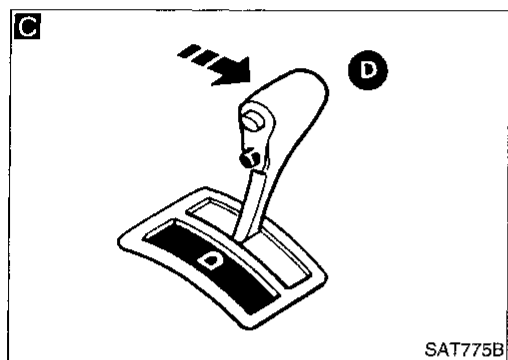
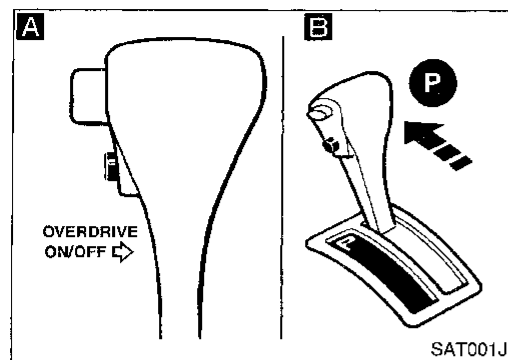

1. Drive vehicle for approx. 10 minutes to warm engine oil and ATF up to operating temperature.
ATF operating temperature:
 50 - 80°C (122 - 176°F)

A B
 1. Park vehicle on flat surface.
 2. Set overdrive control switch to "ON" position.
 3. Move selector lever to "P" position.
 4. Start engine.

C
 Move selector lever to "D" position.

D
 Accelerate vehicle by constantly depressing accelerator pedal half-way.

Does vehicle start from "D₁"?
Read gear position.
 No → Go to "8. Vehicle Cannot Be Started From D₁", AT-180. Continue ROAD TEST.
 Yes →

E
 Does A/T shift from "D₁" to "D₂" at the specified speed?
Read gear position, throttle opening and vehicle speed.
 Specified speed when shifting from "D₁" to "D₂":
 Refer to Shift schedule, AT-301.
 No → Go to "9. A/T Does Not Shift: D₁ → D₂ Or Does Not Kickdown: D₄ → D₂", AT-181. Continue ROAD TEST.
 Yes →

F
 Does A/T shift from "D₂" to "D₃" at the specified speed?
Read gear position, throttle position and vehicle speed.
 Specified speed when shifting from "D₂" to "D₃":
 Refer to Shift schedule, AT-301.
 No → Go to "10. A/T Does Not Shift: D₂ → D₃", AT-182. Continue ROAD TEST.
 Yes →

Yes
 (A)
 (Go to next page.)

GI
 MA
 EM
 LC
 EC
 FE
 CL
 MT
AT
 FA
 RA
 BR
 ST
 RS
 BT
 HA
 EL
 IDX

TROUBLE DIAGNOSIS — Basic Inspection

Road Test (Cont'd)

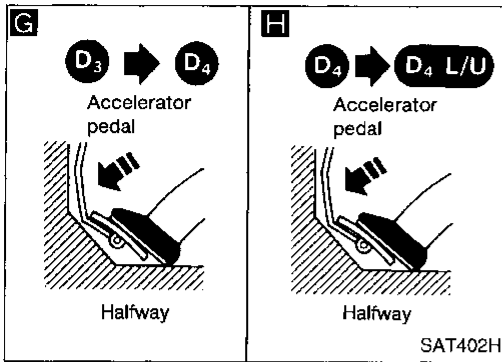

G

Does A/T shift from "D₃" to "D₄" at the specified speed?

Read gear position, throttle position and vehicle speed.

Specified speed when shifting from D₃ to D₄:
Refer to Shift schedule, AT-301.

No → Go to "11. A/T Does Not Shift: D₃ → D₄", AT-183. Continue ROAD TEST.

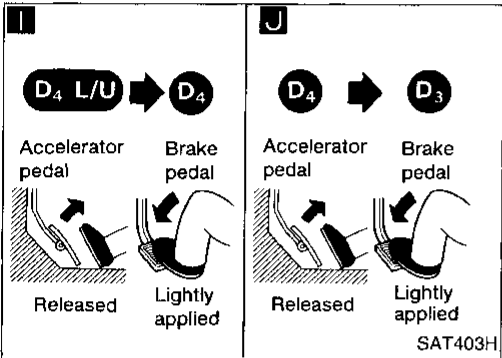

H

Does A/T perform lock-up at the specified speed?

Read vehicle speed, throttle position when lock-up duty becomes 94%.

Specified speed when lock-up occurs:
Refer to Shift schedule, AT-301.

No → Go to "12. A/T Does Not Perform Lock-up", AT-184. Continue ROAD TEST.

Does A/T hold lock-up condition for more than 30 seconds?

No → Go to "13. A/T Does Not Hold Lock-up Condition", AT-185.

I

1. Release accelerator pedal.
2. Is lock-up released when accelerator pedal is released?

No → Go to "14. Lock-up Is Not Released", AT-185. Continue ROAD TEST.

J

1. Decelerate vehicle by applying foot brake lightly.
2. Does engine speed return to idle smoothly when A/T is shifted from "D₄" to "D₃"?

Read gear position and engine speed.

No → Go to "15. Engine Speed Does Not Return To Idle (Light Braking D₄ → D₃)", AT-186. Continue ROAD TEST.

1. Stop vehicle.
2. Go to "CRUISE TEST — Part 2", AT-65.

Road Test (Cont'd)

CRUISE TEST — Part 2

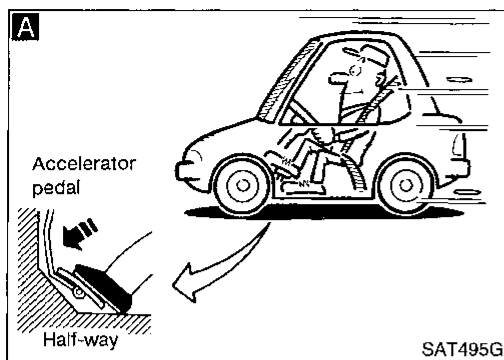

1. Confirm overdrive control switch is in "ON" position.
2. Confirm selector lever is in "D" position.

A

1. Accelerate vehicle by half throttle again.
2. Does vehicle start from "D₁"?



Read gear position.

No

Go to "16. Vehicle Does Not Start From D₁", AT-187.
Continue ROAD TEST.

Yes

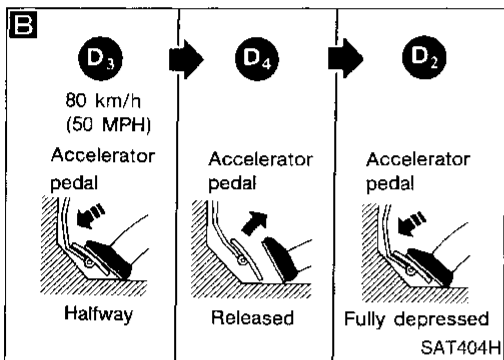

B

1. Accelerate vehicle to 80 km/h (50 MPH) as shown in illustration.
2. Release accelerator pedal and then quickly depress it fully.
3. Does A/T shift from "D₄" to "D₂" as soon as accelerator pedal is depressed fully?



Read gear position and throttle position.

No

Go to "9. A/T Does Not Shift: D₁ → D₂ Or Does Not Kickdown: D₄ → D₂", AT-181.
Continue ROAD TEST.

Yes

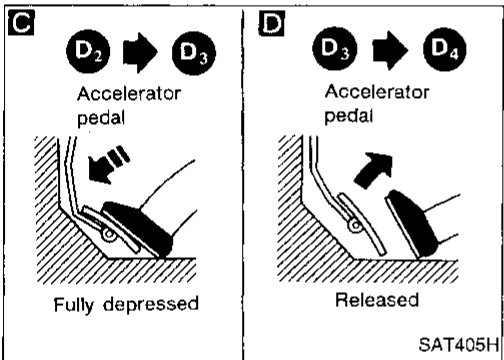

C

- Does A/T shift from "D₂" to "D₃" at the specified speed?



Read gear position, throttle position and vehicle speed.

**Specified speed when shifting from "D₂" to "D₃":
Refer to Shift schedule, AT-301.**

No

Go to "10. A/T Does Not Shift: D₂ → D₃", AT-182.
Continue ROAD TEST.

Yes

D

- Release accelerator pedal after shifting from "D₂" to "D₃".
Does A/T shift from "D₃" to "D₄" and does vehicle decelerate by engine brake?



Read gear position, throttle position and vehicle speed.

No

Go to "11. A/T Does Not Shift: D₃ → D₄", AT-183.
Continue ROAD TEST.

Yes

1. Stop vehicle.
2. Go to "CRUISE TEST — Part 3", AT-66.

GI

MA

EM

LC

EC

FE

CL

MT

AT

FA

RA

BR

ST

RS

BT

HA

EL

IDX

Road Test (Cont'd)

CRUISE TEST — Part 3

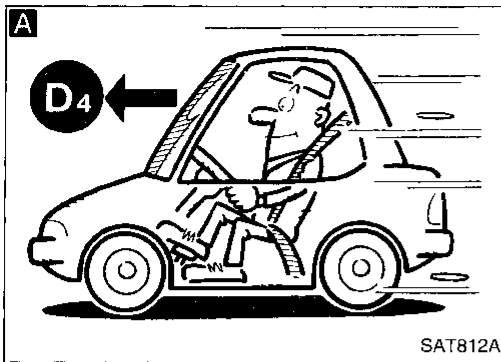

1. Confirm overdrive control switch is in "ON" position.
2. Confirm selector lever is in "D" position.

A
Accelerate vehicle using half-throttle to "D₄".

B
Release accelerator pedal.

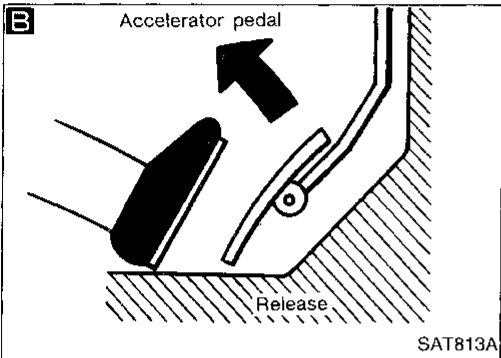

C
Set overdrive control switch to "OFF" position while driving in "D₄".

D
Does A/T shift from "D₄" to "D₃" (O/D OFF)?
Read gear position and vehicle speed.

No
Go to "17. A/T Does Not Shift: D₄ → D₃, When Overdrive Control Switch "ON" → "OFF", AT-187. Continue ROAD TEST.

E
Does vehicle decelerate by engine brake?

No
Go to "15. Engine Speed Does Not Return To Idle (Light Braking D₄ → D₃)", AT-186. Continue ROAD TEST.

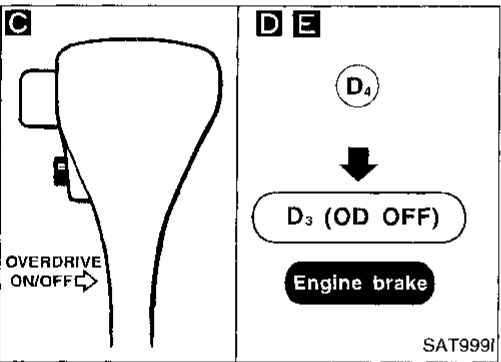

F
Move selector lever from "D" to "2" position while driving in "D₃" (O/D OFF).

G
Does A/T shift from "D₃" (O/D OFF) to "2₂"?
Read gear position.

No
Go to "18. A/T Does Not Shift: D₃ → D₂, When Selector Lever "D" → "2" Position", AT-188. Continue ROAD TEST.

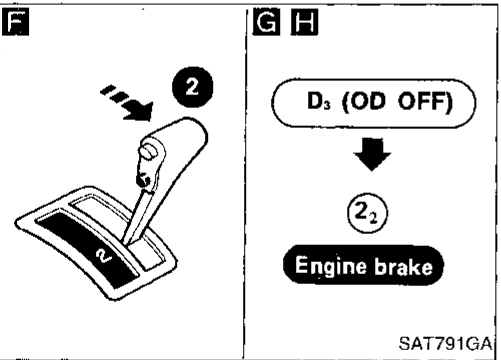

H
Does vehicle decelerate by engine brake?

No
Go to "15. Engine Speed Does Not Return To Idle (Light Braking D₄ → D₃)", AT-186. Continue ROAD TEST.

I J
1. Move selector lever from "2" to "1" position while driving in "2₂".
2. Does A/T shift from "2₂" to "1₁" position?
Read gear position.

No
Go to "19. A/T Does Not Shift: 2₂ → 1₁, When Selector Lever "2" → "1" Position", AT-188. Continue ROAD TEST.

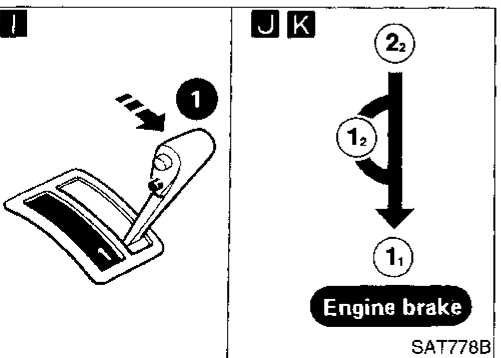

K
Does vehicle decelerate by engine brake?

No
Go to "20. Vehicle Does Not Decelerate By Engine Brake", AT-189. Continue ROAD TEST.

1. Stop vehicle.
2. Perform self-diagnosis. Refer to SELF-DIAGNOSTIC PROCEDURE, AT-36.

TROUBLE DIAGNOSIS — General Description

Symptom Chart

Reference page (AT-)		ON vehicle									OFF vehicle																					
		52, 206	205	86, 90, 167	55	204, 140	145, 135	122, 157	81, 204	204	215, 231	249, 252	256, 264	256	262, 273	—																
Reference page (AT-)		Fluid level	Control cable adjustment	Inhibitor switch adjustment	Throttle position sensor (Adjustment)	Revolution sensor and vehicle speed sensor	Engine speed signal	Engine idling rpm	Line pressure	Control valve assembly	Shift solenoid valve A	Shift solenoid valve B	Line pressure solenoid valve	Torque converter clutch solenoid valve	Overrun clutch solenoid valve	A/T fluid temperature sensor	Accumulator N-D	Accumulator servo release	Ignition switch and starter	Torque converter	Oil pump	Reverse clutch	High clutch	Forward clutch	Forward one-way clutch	Overrun clutch	Low one-way clutch	Low & reverse brake	Brake band	Parking components		
175	Engine does not start in "N", "P" positions.	2	3															1														
175	Engine starts in positions other than "N" and "P".	1	2																													
—	Transaxle noise in "P" and "N" positions.	1		3	4	5		2												7	6											
175	Vehicle moves when changing into "P" position or parking gear does not disengage when shifted out of "P" position.	1																												2		
176	Vehicle runs in "N" position.	1																				3		2		4						
178	Vehicle will not run in "R" position (but runs in "D", "2" and "1" positions). Clutch slips. Very poor acceleration.	1					2	4				3										5	6	7		8		9				
—	Vehicle braked when shifting into "R" position.	1	2				3	5			4												6	8		9			7			
—	Sharp shock in shifting from "N" to "D" position.			2		5	1	3	7			6			4	8								9								
—	Vehicle will not run in "D" and "2" positions (but runs in "1" and "R" positions).	1																								2						
179	Vehicle will not run in "D", "1", "2" positions (but runs in "R" position). Clutch slips. Very poor acceleration.	1					2	4				3				5						6	7	8	9		10					
—	Clutches or brakes slip somewhat in starting.	1	2		3		4	6			5					7				12	11	9		8				10				
—	Excessive creep.						1																									
178, 179	No creep at all.	1					2	3												6	5			4								
—	Failure to change gear from "D ₁ " to "D ₂ ".	2	1		5			4	3																				6			
—	Failure to change gear from "D ₂ " to "D ₃ ".	2	1		5			4	3														6						7			
—	Failure to change gear from "D ₃ " to "D ₄ ".	2	1		4				3							5													6			
181, 182, 183	Too high a gear change point from "D ₁ " to "D ₂ ", from "D ₂ " to "D ₃ ", from "D ₃ " to "D ₄ ".			1	2				3	4																						
—	Gear change directly from "D ₁ " to "D ₃ " occurs.	1																2											3			
—	Engine stops when shifting lever into "R", "D", "2" and "1".						1	3				2								4												
—	Too sharp a shock in change from "D ₁ " to "D ₂ ".			1			2	4							5	3													6			
—	Too sharp a shock in change from "D ₂ " to "D ₃ ".			1			2	3															4						5			

GI
 MA
 EM
 LC
 EC
 FE
 CL
 MT
AT
 FA
 RA
 BR
 ST
 RS
 BT
 HA
 EL
 IDX

TROUBLE DIAGNOSIS — General Description

Symptom Chart (Cont'd)

Reference page (AT-)		ON vehicle									OFF vehicle																					
		52, 206	205	86, 90, 167	55	204, 140	145, 135	122, 157	81, 204	204	215, 231	249, 252	256, 264	256	262, 273	—																
Reference page (AT-)		Fluid level	Control cable adjustment	Inhibitor switch adjustment	Throttle position sensor (Adjustment)	Revolution sensor and vehicle speed sensor	Engine speed signal	Engine idling rpm	Line pressure	Control valve assembly	Shift solenoid valve A	Shift solenoid valve B	Line pressure solenoid valve	Torque converter clutch solenoid valve	Overrun clutch solenoid valve	A/T fluid temperature sensor	Accumulator N-D	Accumulator servo release	Ignition switch and starter	Torque converter	Oil pump	Reverse clutch	High clutch	Forward clutch	Forward one-way clutch	Overrun clutch	Low one-way clutch	Low & reverse brake	Brake band	Parking components		
—	Numbers are arranged in order of probability. Perform inspections starting with number one and work up. Circled numbers indicate that the transaxle must be removed from the vehicle.																															
—	Too sharp a shock in change from "D ₃ " to "D ₄ ".			1				2	3																	5			4			
—	Almost no shock or clutches slipping in change from "D ₁ " to "D ₂ ".	1		2				3	5									4												6		
—	Almost no shock or slipping in change from "D ₂ " to "D ₃ ".	1		2				3	4																					6		
—	Almost no shock or slipping in change from "D ₃ " to "D ₄ ".	1		2				3	4																					6		
—	Vehicle braked by gear change from "D ₁ " to "D ₂ ".	1																											5	3		
—	Vehicle braked by gear change from "D ₂ " to "D ₃ ".	1																												2		
—	Vehicle braked by gear change from "D ₃ " to "D ₄ ".	1																														
—	Maximum speed not attained. Acceleration poor.	1		2					5	3	4										11	10	6	7					9	8		
—	Failure to change gear from "D ₄ " to "D ₃ ".	1		2					6	4	5	3																	8	7		
—	Failure to change gear from "D ₃ " to "D ₂ " or from "D ₄ " to "D ₂ ".	1		2					5	3	4																			7		
—	Failure to change gear from "D ₂ " to "D ₁ " or from "D ₃ " to "D ₁ ".	1		2					5	3	4																			6	8	
—	Gear change shock felt during deceleration by releasing accelerator pedal.			1				2	4					3																		
—	Too high a change point from "D ₄ " to "D ₃ ", from "D ₃ " to "D ₂ ", from "D ₂ " to "D ₁ ".			1	2																											
—	Kickdown does not operate when depressing pedal in "D ₄ " within kickdown vehicle speed.			1	2					3	4																					
—	Kickdown operates or engine overruns when depressing pedal in "D ₄ " beyond kickdown vehicle speed limit.			2	1					3	4																					
—	Races extremely fast or slips in changing from "D ₄ " to "D ₃ " when depressing pedal.	1		2				3	5		4																					
—	Races extremely fast or slips in changing from "D ₄ " to "D ₂ " when depressing pedal.	1		2				3	6	5	4																					
—	Races extremely fast or slips in changing from "D ₃ " to "D ₂ " when depressing pedal.	1		2				3	5		4					6																
—	Races extremely fast or slips in changing from "D ₄ " or "D ₃ " to "D ₁ " when depressing pedal.	1		2				3	5		4																					
—	Vehicle will not run in any position.	1	2					3			4										9	5		6						8	7	10
—	Transaxle noise in "D", "2", "f" and "R" positions.	1																			2											

TROUBLE DIAGNOSIS — General Description

Symptom Chart (Cont'd)

Reference page (AT-)		ON vehicle									OFF vehicle																				
		52, 206	205	86, 90, 167	55	204, 140	145, 135	122, 157	81, 204	204	215, 231	249, 252	256, 264	256	262, 273	—															
Reference page (AT-)		Fluid level	Control cable adjustment	Inhibitor switch adjustment	Throttle position sensor (Adjustment)	Revolution sensor and vehicle speed sensor	Engine speed signal	Engine idling rpm	Line pressure	Control valve assembly	Shift solenoid valve A	Shift solenoid valve B	Line pressure solenoid valve	Torque converter clutch solenoid valve	Overrun clutch solenoid valve	A/T fluid temperature sensor	Accumulator N-D	Accumulator servo release	Ignition switch and starter	Torque converter	Oil pump	Reverse clutch	High clutch	Forward clutch	Forward one-way clutch	Overrun clutch	Low one-way clutch	Low & reverse brake	Brake band	Parking components	
186	Failure to change from "D ₃ " to "2 ₂ " when changing lever into "2" position.	. 7	1 2	6 5	4 3	⑨	⑧	
—	Gear change from "2 ₂ " to "2 ₃ " in "2" position.	. .	1	
187	Engine brake does not operate in "1" position.	. 2	1 3	4	6 5 7	⑧ .	. .	⑨	
—	Gear change from "1 ₁ " to "1 ₂ " in "1" position.	. 2	1	
—	Does not change from "1 ₂ " to "1 ₁ " in "1" position.	. .	1 .	2	4 3 5	⑥ .	. .	⑦	
—	Large shock changing from "1 ₂ " to "1 ₁ " in "1" position.	1	②	
—	Transaxle overheats.	1 .	. 3	. .	2 4	6 .	. 5	⑭ ⑦	⑧ ⑨	⑩	. .	⑪ .	⑫ .	⑬ ⑩	
—	ATF shoots out during operation. White smoke emitted from exhaust pipe during operation.	1	② ③	④ ⑤	⑥	. .	⑦ .	⑧ .	⑨ ④	
—	Offensive smell at fluid charging pipe.	1	② ③	④ ⑤	⑦ .	. .	⑧ .	⑨ ⑥	
—	Torque converter is not locked up.	. .	3 1	2 4	. 6	8	7 .	5	⑨
—	Torque converter clutch piston slip.	1 .	. 2	. .	. 3	6 .	. 5	4	⑦
184	Lock-up point is extremely high or low.	. .	. 1	2 .	. .	4	3
—	A/T does not shift to "D ₄ " when driving with overdrive control switch "ON".	. .	2 1	3 .	. 8	6 4	5 .	7	⑩ .	. .	⑨
—	Engine is stopped at "R", "D", "2" and "1" positions.	1	5 4	3	2

GI
 MA
 EM
 LG
 EC
 FE
 CL
 MT
AT
 FA
 RA
 BR
 ST
 RS
 BT
 HA
 EL
 IDX

TROUBLE DIAGNOSIS — General Description

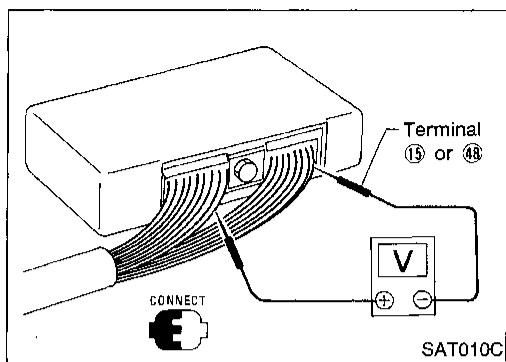

TCM Terminals and Reference Value

PREPARATION

- Measure voltage between each terminal and terminal ⑮ or ④⑧ by following "TCM INSPECTION TABLE".

TCM HARNESS CONNECTOR TERMINAL LAYOUT

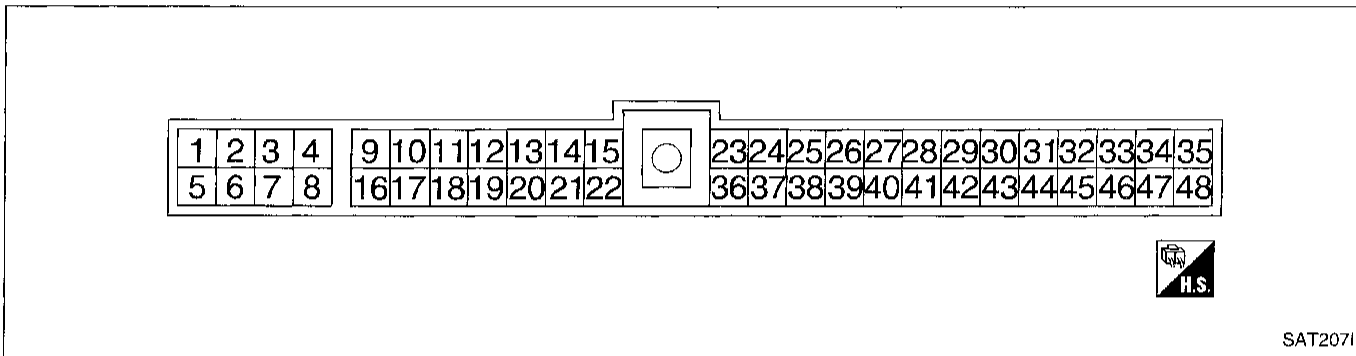

TCM INSPECTION TABLE

(Data are reference values.)

Terminal No.	Wire color	Item	Condition	Judgement standard
1	R/W	Line pressure solenoid valve	When releasing accelerator pedal after warming up engine.	1.5 - 2.5V
			When depressing accelerator pedal fully after warming up engine.	0.5V or less
2	P/B	Line pressure solenoid valve (with dropping resistor)	When releasing accelerator pedal after warming up engine.	5 - 14V
			When depressing accelerator pedal fully after warming up engine.	0.5V or less
3	OR/B	O/D OFF indicator lamp	When setting overdrive control switch in "OFF" position.	1V or less
			When setting overdrive control switch in "ON" position.	Battery voltage
4	SB	Power source	When turning ignition switch to "ON".	Battery voltage
			When turning ignition switch to "OFF".	1V or less

TROUBLE DIAGNOSIS — General Description











TCM Terminals and Reference Value (Cont'd)

Terminal No.	Wire color	Item	Condition	Judgement standard	
5	R	Torque converter clutch solenoid valve	When A/T performs lock-up.	8 - 15V	GI
			When A/T does not perform lock-up.	1V or less	MA
6	L/W	Shift solenoid valve A	When shift solenoid valve A operates. (When driving in "D ₁ " or "D ₄ ".)	Battery voltage	EM
			When shift solenoid valve A does not operate. (When driving in "D ₂ " or "D ₃ ".)	1V or less	LC
7	L/Y	Shift solenoid valve B	When shift solenoid valve B operates. (When driving in "D ₁ " or "D ₂ ".)	Battery voltage	EC
			When shift solenoid valve B does not operate. (When driving in "D ₃ " or "D ₄ ".)	1V or less	FE
8	L/B	Overrun clutch solenoid valve	When overrun clutch solenoid valve operates.	Battery voltage	CL
			When overrun clutch solenoid valve does not operate.	1V or less	MT
9	SB	Power source	Same as No. 4		
10*	Y/B	DT1	—	—	AT
11*	Y/G	DT2	—	—	
12*	Y/R	DT3	—	—	FA
13*	G/OR	"N" position signal	When setting selector lever to "N" or "P" position.	1V or less	
			When setting selector lever to other positions.	Approximately 5V	RA
14	Y	Closed throttle position switch (in throttle position switch)	When releasing accelerator pedal after warming up engine.	Battery voltage	BR
			When depressing accelerator pedal after warming up engine.	1V or less	ST
15	B	Ground	—	—	
16	OR/L	Inhibitor "1" position switch	When setting selector lever to "1" position.	Battery voltage	RS
			When setting selector lever to other positions.	1V or less	BT
17	B/Y	Inhibitor "2" position switch	When setting selector lever to "2" position.	Battery voltage	HA
			When setting selector lever to other positions.	1V or less	
18	W/G	Inhibitor "D" position switch	When setting selector lever to "D" position.	Battery voltage	EL
			When setting selector lever to other positions.	1V or less	IDX

*: These terminals are connected to the ECM (ECCS control module).

TROUBLE DIAGNOSIS — General Description









TCM Terminals and Reference Value (Cont'd)

Terminal No.	Wire color	Item	Condition		Judgement standard
19	GY/R	Inhibitor "N" or "P" position switch		When setting selector lever to "N" or "P" position.	Battery voltage
				When setting selector lever to other positions.	1V or less
20	G	Inhibitor "R" position switch		When setting selector lever to "R" position.	Battery voltage
				When setting selector lever to other positions.	1V or less
21	LG	Wide open throttle position switch (in throttle position switch)		When depressing accelerator pedal more than half-way after warming up engine.	Battery voltage
				When releasing accelerator pedal after warming up engine.	1V or less
22	—	—	—	—	—
23	R/B	Power source (Memory back-up)	 or 	When turning ignition switch to "OFF".	Battery voltage
				When turning ignition switch to "ON".	Battery voltage
24	L/OR	Engine speed signal	 	When engine runs at idle speed.	0.5 - 1.5V
25	L	Revolution sensor (Measure in AC range)		When vehicle cruises at 30 km/h (19 MPH).	1V or more Voltage rises gradually in response to vehicle speed.
				When vehicle parks.	0V
26	—	—	—	—	—
27	PU/R	Vehicle speed sensor		When moving vehicle at 2 to 3 km/h (1 to 2 MPH) for 1 m (3 ft) or more.	Voltage varies between less than 1V and more than 4.5V
28*	G/B	—	—	—	—
29	—	—		—	—
30*	GY/L	—	—	—	—
31	R	Throttle position sensor (Power source)		—	4.5 - 5.5V
32	—	—	—	—	—

*: These terminals are connected to the Data link connector for CONSULT.

TROUBLE DIAGNOSIS — General Description

TCM Terminals and Reference Value (Cont'd)

Terminal No.	Wire color	Item	Condition	Judgement standard		
33	BR	A/T fluid temperature sensor		When ATF temperature is 20°C (68°F).	Approximately 1.5V	GI
				When ATF temperature is 80°C (176°F).	Approximately 0.5V	MA
34	GY	Throttle position sensor	 	When depressing accelerator pedal slowly after warming up engine. (Voltage rises gradually in response to throttle position.)	Fully-closed throttle: Approximately 0.5V	EM
					Fully-open throttle: Approximately 4V	LC
35	B	Throttle position sensor (Ground)		—	—	EC
36	—	—		—	—	FE
37	OR	ASCD cruise signal		When ASCD cruise is being performed. ("CRUISE" light comes on.)	Battery voltage	CL
				When ASCD cruise is not being performed. ("CRUISE" light does not come on.)	1V or less	MT
38	—	—		—	—	AT
39	G/R	Overdrive control switch	 	When setting overdrive control switch in "ON" position	Battery voltage	FA
				When setting overdrive control switch in "OFF" position	1V or less	RA
40	W/B	ASCD OD cut signal		When "ACCEL" set switch on ASCD cruise is in "D ₄ " position.	5 - 8V	BR
				When "ACCEL" set switch on ASCD cruise is in "D ₃ " position.	1V or less	ST
41	—	—		—	—	RS
42	—	—		—	—	BT
43	—	—		—	—	HA
44	—	—		—	—	EL
45*	PU	OBD-II output		—	—	IDX
46	—	—		—	—	
47	—	—		—	—	
48	B	Ground		—	—	

* This terminal is connected to the ECM (ECCS control module).

TROUBLE DIAGNOSIS FOR POWER SUPPLY

Main Power Supply and Ground Circuit WIRING DIAGRAM — AT — MAIN

AT-MAIN-01

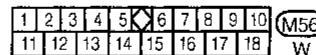
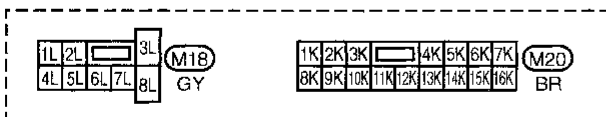
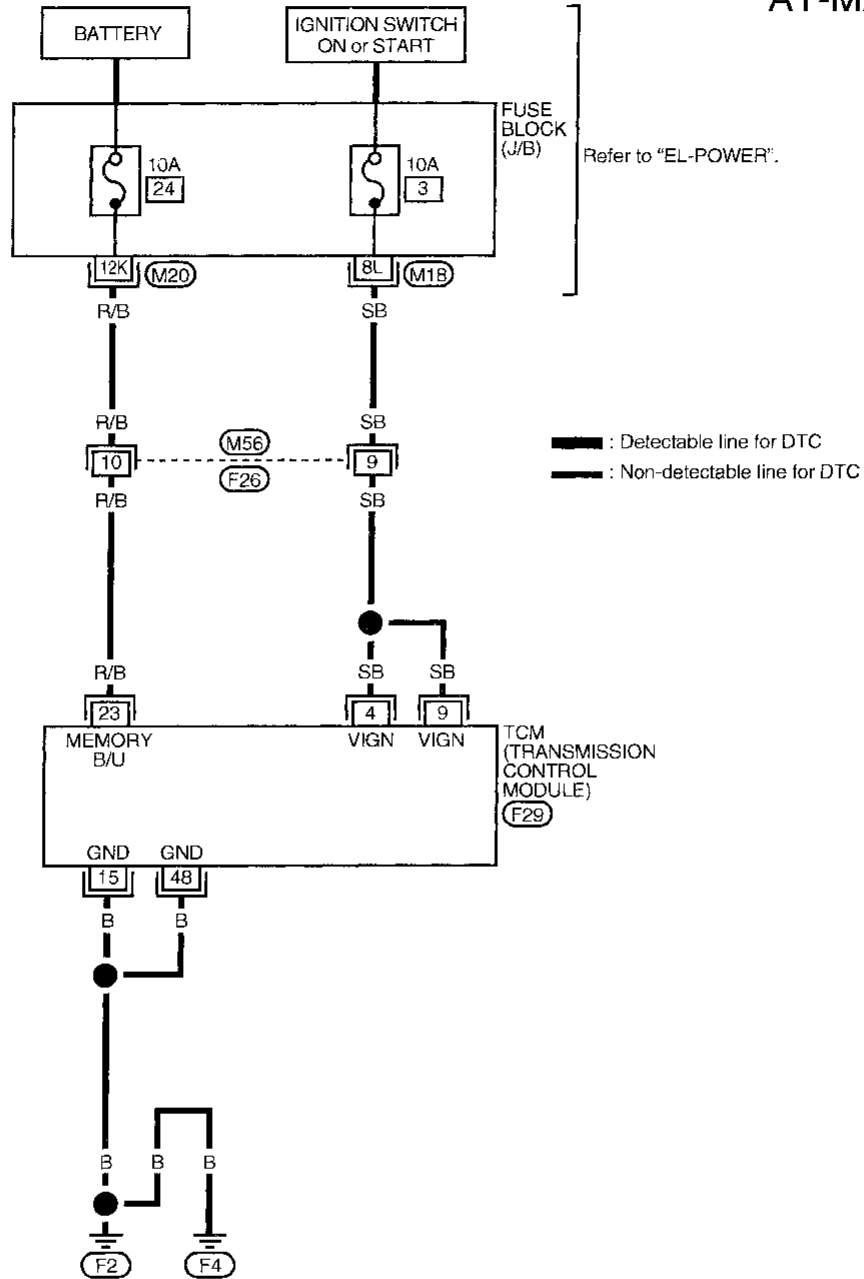







TROUBLE DIAGNOSIS FOR POWER SUPPLY

Main Power Supply and Ground Circuit (Cont'd)

TCM TERMINALS AND REFERENCE VALUE

Remarks: Specification data are reference values.

Terminal No.	Wire color	Item	Condition	Judgement standard
4	SB	Power source	 When turning ignition switch to "ON".	Battery voltage
			 When turning ignition switch to "OFF".	1V or less
9	SB	Power source	Same as No. 4	—
15	B	Ground		
23	R/B	Power source (Memory back-up)	 or  When turning ignition switch to "OFF".	Battery voltage
			When turning ignition switch to "ON".	Battery voltage
48	B	Ground	 	—

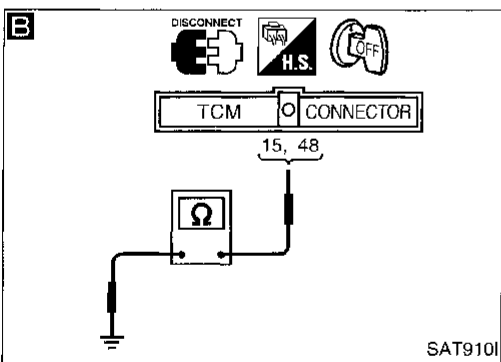
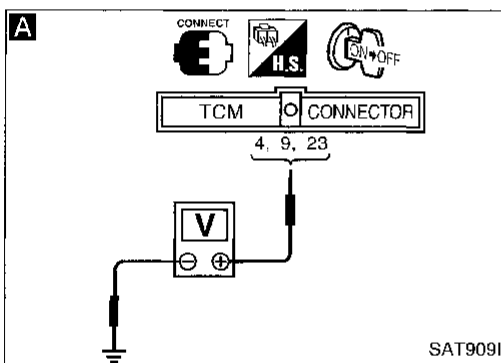

DIAGNOSTIC PROCEDURE

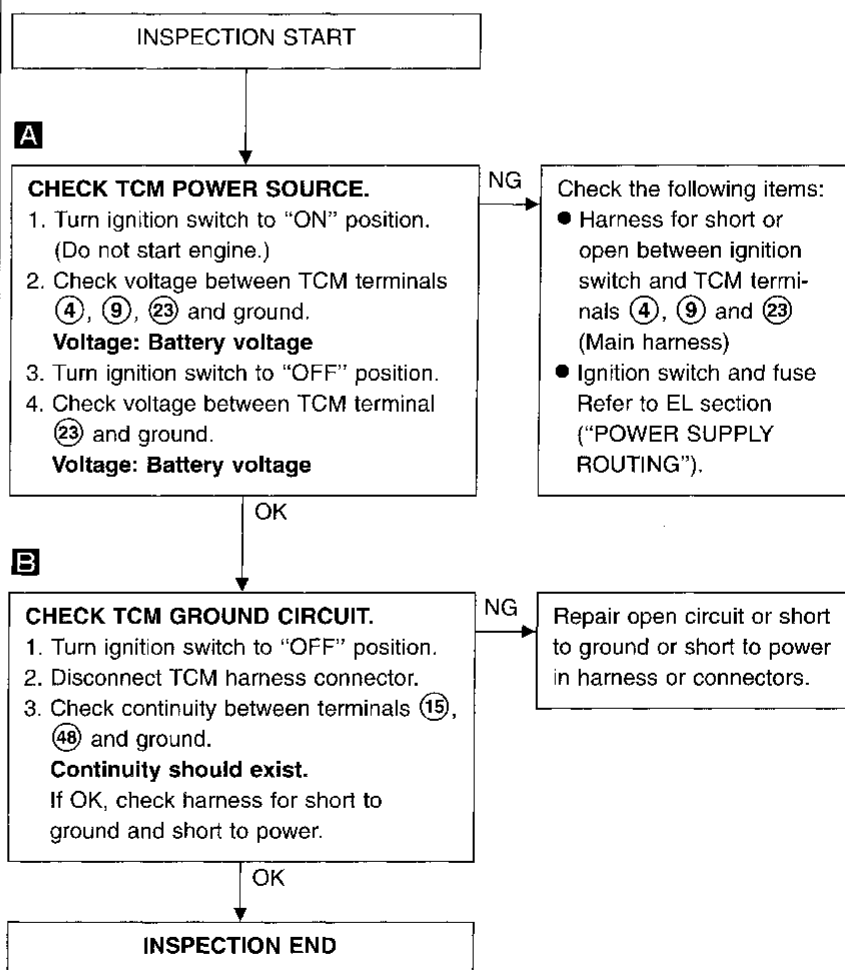

TROUBLE DIAGNOSIS FOR DTC P0705

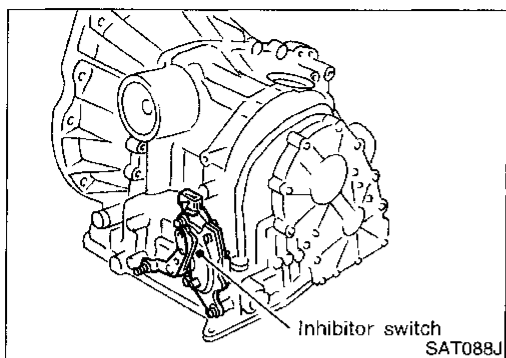

Inhibitor Switch

DESCRIPTION

Detects the selector lever position and sends a signal to the TCM.

TCM TERMINALS AND REFERENCE VALUE

Remarks: Specification data are reference values.

Terminal No.	Wire color	Item	Condition	Judgement standard
16	OR/L	Inhibitor "1" position switch	When setting selector lever to "1" position.	Battery voltage
			When setting selector lever to other positions.	1V or less
17	B/Y	Inhibitor "2" position switch	When setting selector lever to "2" position.	Battery voltage
			When setting selector lever to other positions.	1V or less
18	W/G	Inhibitor "D" position switch	When setting selector lever to "D" position.	Battery voltage
			When setting selector lever to other positions.	1V or less
19	GY/R	Inhibitor "N" or "P" position switch	When setting selector lever to "N" or "P" position.	Battery voltage
			When setting selector lever to other positions.	1V or less
20	G	Inhibitor "R" position switch	When setting selector lever to "R" position.	Battery voltage
			When setting selector lever to other positions.	1V or less



ON BOARD DIAGNOSIS LOGIC

Diagnostic trouble code	Malfunction is detected when ...	Check item (Possible cause)
: INHIBITOR SW/CIRC : P0705 : MIL Code No. 1101	TCM does not receive the correct voltage signal from the switch based on the gear position.	<ul style="list-style-type: none"> ● Harness or connectors (The inhibitor switch circuit is open or shorted.) ● Inhibitor switch

TROUBLE DIAGNOSIS FOR DTC P0705

Inhibitor Switch (Cont'd)

DIAGNOSTIC TROUBLE CODE (DTC) CONFIRMATION PROCEDURE

CAUTION:

- Always drive vehicle at a safe speed.
- If conducting this "DTC CONFIRMATION PROCEDURE" again, always turn ignition switch "OFF" and wait at least 5 seconds before continuing.

After the repair, perform the following procedure to confirm the malfunction is eliminated.

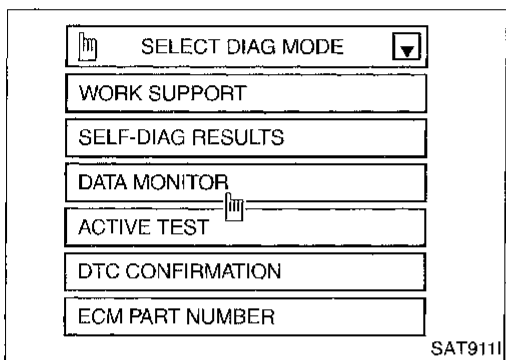
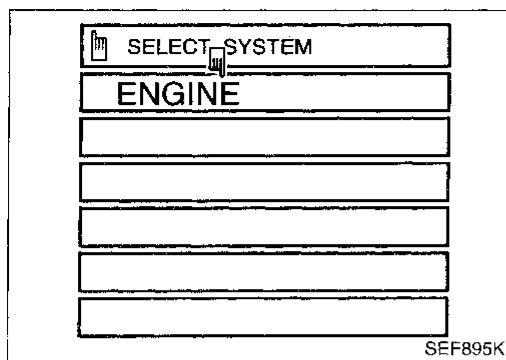

- 1) Turn ignition switch "ON".
- 2) Select "DATA MONITOR" mode for "ENGINE" with CONSULT.
- 3) Start engine and maintain the following conditions for at least 5 consecutive seconds.
VHCL SPEED SE: 10 km/h (6 MPH) or more
THRTL POS SEN: More than 1.3V
Selector lever: D position (OD "ON" or "OFF")

-
- OR
- 1) Start engine.
 - 2) Drive vehicle under the following conditions:
 Selector lever in "D", overdrive control switch in "ON" or "OFF" position, vehicle speed higher than 10 km/h (6 MPH), throttle position sensor more than 1.3V and driving for more than 5 seconds.
 - 3) Select "MODE 7" with GST.

-
- OR
- 1) Start engine.
 - 2) Drive vehicle under the following conditions:
 Selector lever in "D", overdrive control switch in "ON" or "OFF" position, vehicle speed higher than 10 km/h (6 MPH), throttle opening greater than 1/2 of the full throttle position and driving for more than 5 seconds.
 - 3) Perform self-diagnosis for ECM.
 Refer to EC section ["Malfunction Indicator Lamp (MIL)", "ON BOARD DIAGNOSTIC SYSTEM DESCRIPTION"].

GI
MA
EM
LC
EC
FE
CL
MT
AT
FA
EA
BR
ST
RS
BT
HA
EL
IDX

TROUBLE DIAGNOSIS FOR DTC P0705

Inhibitor Switch (Cont'd)

WIRING DIAGRAM — AT — INH/SW

AT-INH/SW-01

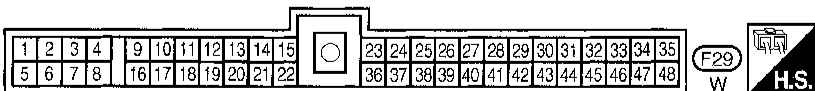
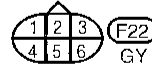
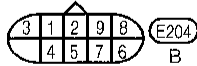
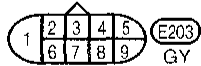
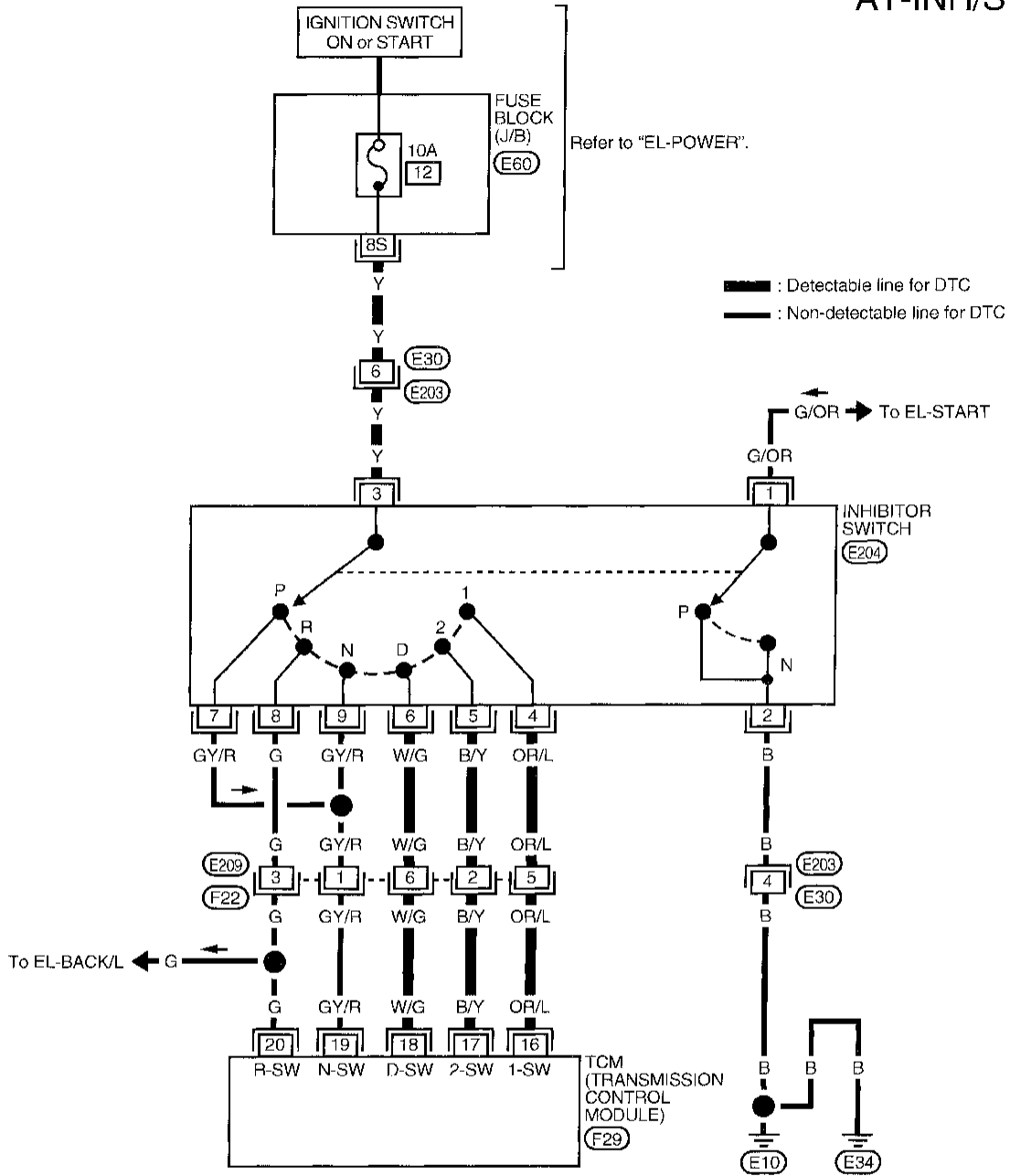

TROUBLE DIAGNOSIS FOR DTC P0705

Inhibitor Switch (Cont'd) DIAGNOSTIC PROCEDURE

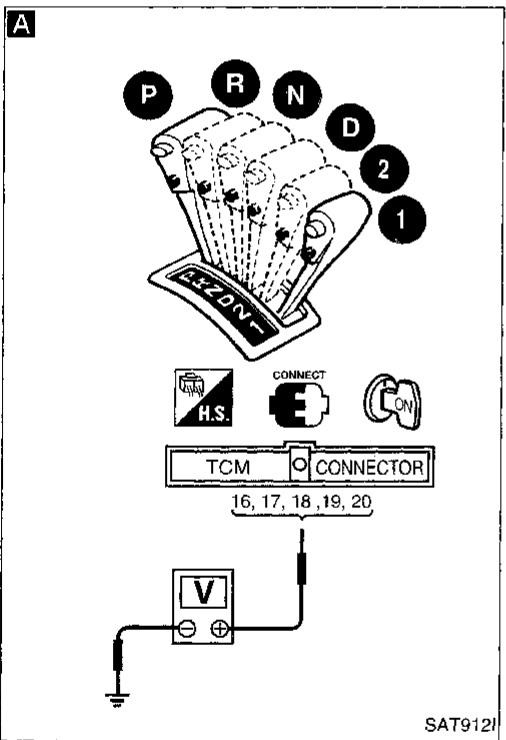
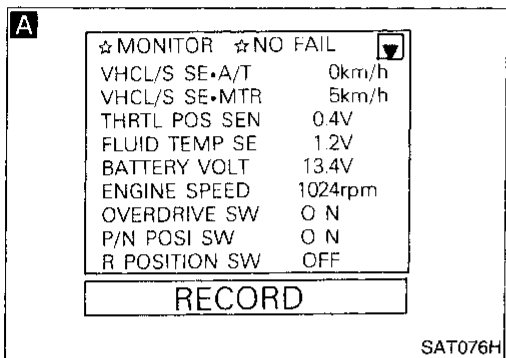
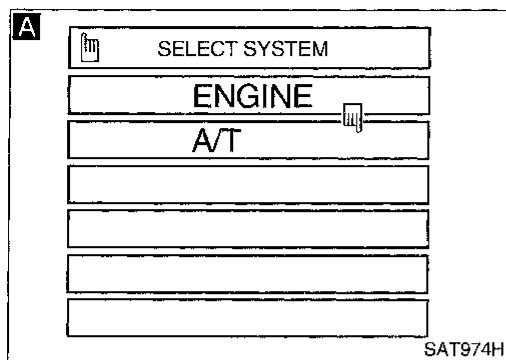

INSPECTION START

A

CHECK INHIBITOR SWITCH CIRCUIT.

- Turn ignition switch to "ON" position. (Do not start engine.)
- Select "ECU INPUT SIGNALS" in "DATA MONITOR" mode for "A/T" with CONSULT.
- Read out "P/N", "R", "D", "2" and "1" position switches moving selector lever to each position. Check the signal of the selector lever position is indicated properly.

OR

- Turn ignition switch to "ON" position. (Do not start engine.)
- Check voltage between TCM terminals ⑰, ⑱, ⑲, ⑳ and ground while moving selector lever through each position.

Voltage:

B: Battery voltage
0: 0V

Lever position	Terminal No.				
	⑲	⑳	⑱	⑰	⑰
P, N	B	0	0	0	0
R	0	B	0	0	0
D	0	0	B	0	0
2	0	0	0	B	0
1	0	0	0	0	B

OK

Perform Diagnostic Trouble Code (DTC) confirmation procedure, AT-77.

OK

INSPECTION END

NG

Check the following items:

- Inhibitor switch Refer to "Component Inspection", AT-80.
- Harness for short or open between ignition switch and inhibitor switch (Main harness)
- Harness for short or open between inhibitor switch and TCM (Main harness)
- Ignition switch and fuse Refer to EL section ("POWER SUPPLY ROUTING").

NG

- Perform TCM input/output signal inspection.
- If NG, recheck TCM pin terminals for damage or loose connection with harness connector.

TROUBLE DIAGNOSIS FOR DTC P0705

Inhibitor Switch (Cont'd)

COMPONENT INSPECTION

Inhibitor switch

1. Check continuity between terminals ① and ② and between terminals ③ and ④, ⑤, ⑥, ⑦, ⑧, ⑨ while moving manual shaft through each position.

Lever position	Terminal No.	
P	① — ②	③ — ⑨
R	③ — ⑧	
N	① — ②	③ — ⑦
D	③ — ⑥	
2	③ — ⑤	
1	③ — ④	

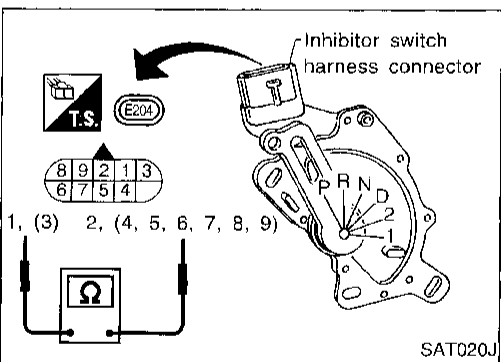
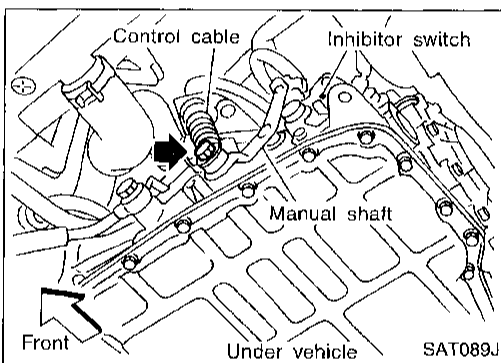
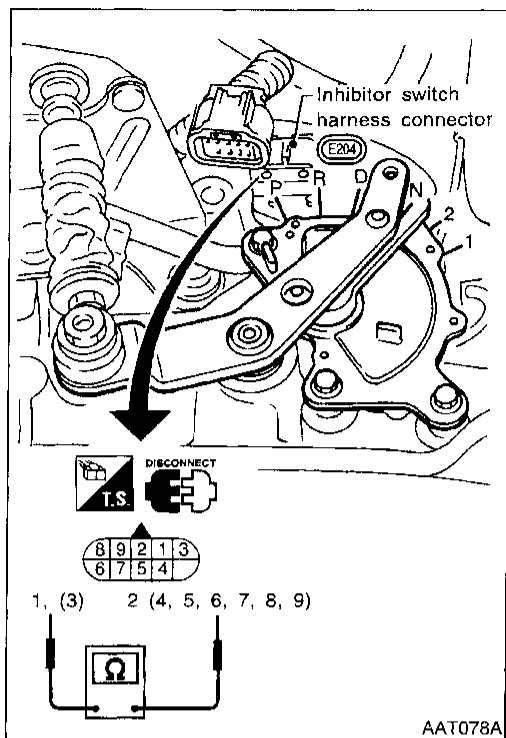

2. If NG, check again with manual control cable disconnected from manual shaft of A/T assembly. Refer to step 1.
3. If OK on step 2, adjust manual control cable. Refer to AT-206.

4. If NG on step 2, remove inhibitor switch from A/T and check continuity of inhibitor switch terminals. Refer to step 1.
5. If OK on step 4, adjust inhibitor switch. Refer to AT-205.
6. If NG on step 4, replace inhibitor switch.

TROUBLE DIAGNOSIS FOR DTC P0710

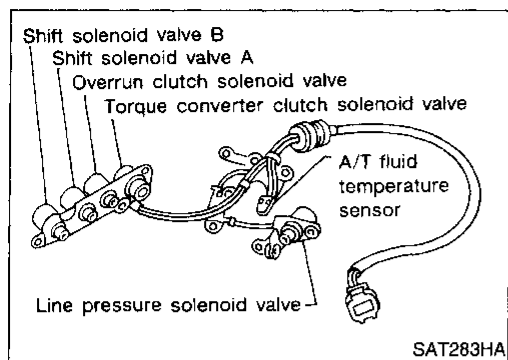

A/T Fluid Temperature Sensor

DESCRIPTION

The A/T fluid temperature sensor detects the A/T fluid temperature and sends a signal to the TCM.

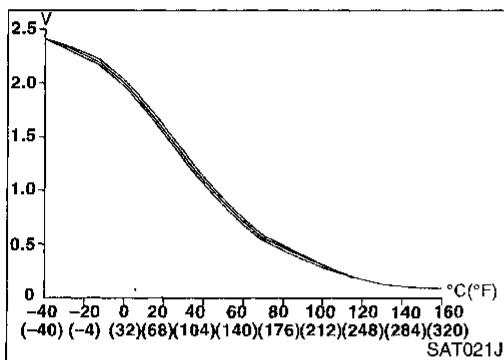

CONSULT REFERENCE VALUE IN DATA MONITOR MODE

Remarks: Specification data are reference values.

Monitor item	Condition	Specification
A/T fluid temperature sensor	Cold [20°C (68°F)]	Approximately 1.5V
	Hot [80°C (176°F)]	Approximately 0.5V

TCM TERMINALS AND REFERENCE VALUE

Remarks: Specification data are reference values.

Terminal No.	Wire color	Item	Condition	Judgement standard
33	BR	A/T fluid temperature sensor	When ATF temperature is 20°C (68°F).	Approximately 1.5V
			When ATF temperature is 80°C (176°F).	Approximately 0.5V
35	B	Throttle position sensor (Ground)	—	—

ON BOARD DIAGNOSIS LOGIC

Diagnostic trouble code	Malfunction is detected when ...	Check item (Possible cause)
: ATF TEMP SEN/CIRC : P0710 : MIL Code No. 1208	TCM receives an excessively low or high voltage from the sensor.	<ul style="list-style-type: none"> • Harness or connectors (The sensor circuit is open or shorted.) • A/T fluid temperature sensor

TROUBLE DIAGNOSIS FOR DTC P0710

A/T Fluid Temperature Sensor (Cont'd) DIAGNOSTIC TROUBLE CODE (DTC) CONFIRMATION PROCEDURE

CAUTION:

- Always drive vehicle at a safe speed.
- If conducting this "DTC CONFIRMATION PROCEDURE" again, always turn ignition switch "OFF" and wait at least 5 seconds before continuing.

After the repair, perform the following procedure to confirm the malfunction is eliminated.

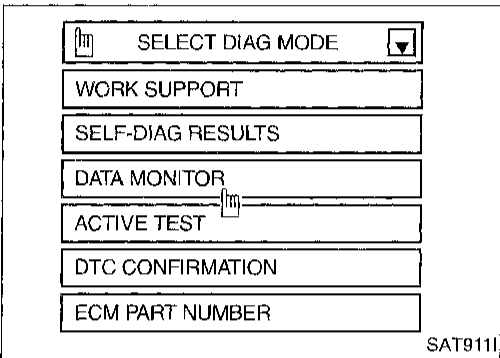
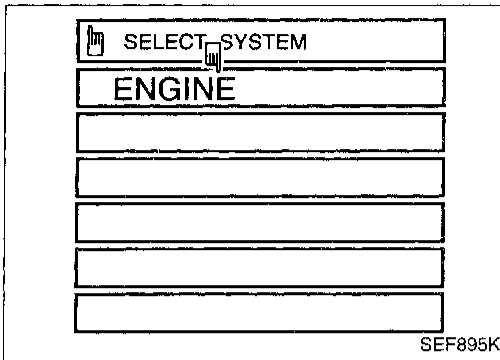

-  1) Turn ignition switch "ON" and select "DATA MONITOR" mode for "ENGINE" with CONSULT.

- 2) Start engine and maintain the following conditions for at least 10 minutes (Total). (It is not necessary to maintain continuously.)

CMPS-RPM (REF): 450 rpm or more

VHCL SPEED SE: 10 km/h (6 MPH) or more

THRTL POS SEN: More than 1.2V

Selector lever: D position (OD "ON")

OR



- 1) Start engine.
- 2) Drive vehicle under the following conditions:
Selector lever in "D" (OD "ON"), vehicle speed higher than 10 km/h (6 MPH), throttle opening greater than 1/8 of the full open position, engine speed higher than 450 rpm and driving for more than 10 minutes (Total).
- 3) Select "MODE 7" with GST.

OR



- 1) Start engine.
- 2) Drive vehicle under the following conditions:
Selector lever in "D" (OD "ON"), vehicle speed higher than 10 km/h (6 MPH), throttle opening greater than 1/8 of the full open position, engine speed higher than 450 rpm and driving for more than 10 minutes (Total).
- 3) Perform self-diagnosis for ECM.
Refer to EC section ["Malfunction Indicator Lamp (MIL)", "ON BOARD DIAGNOSTIC SYSTEM DESCRIPTION"].

TROUBLE DIAGNOSIS FOR DTC P0710

A/T Fluid Temperature Sensor (Cont'd)

WIRING DIAGRAM — AT — FTS

AT-FTS-01

: Detectable line for DTC
 : Non-detectable line for DTC

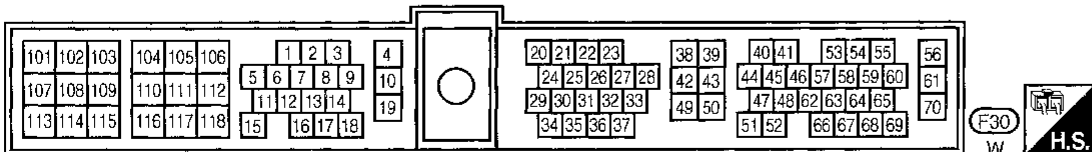
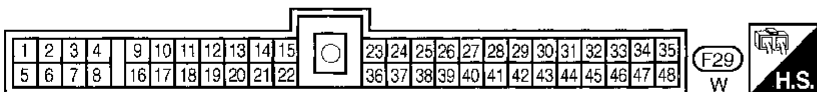
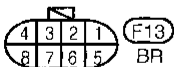
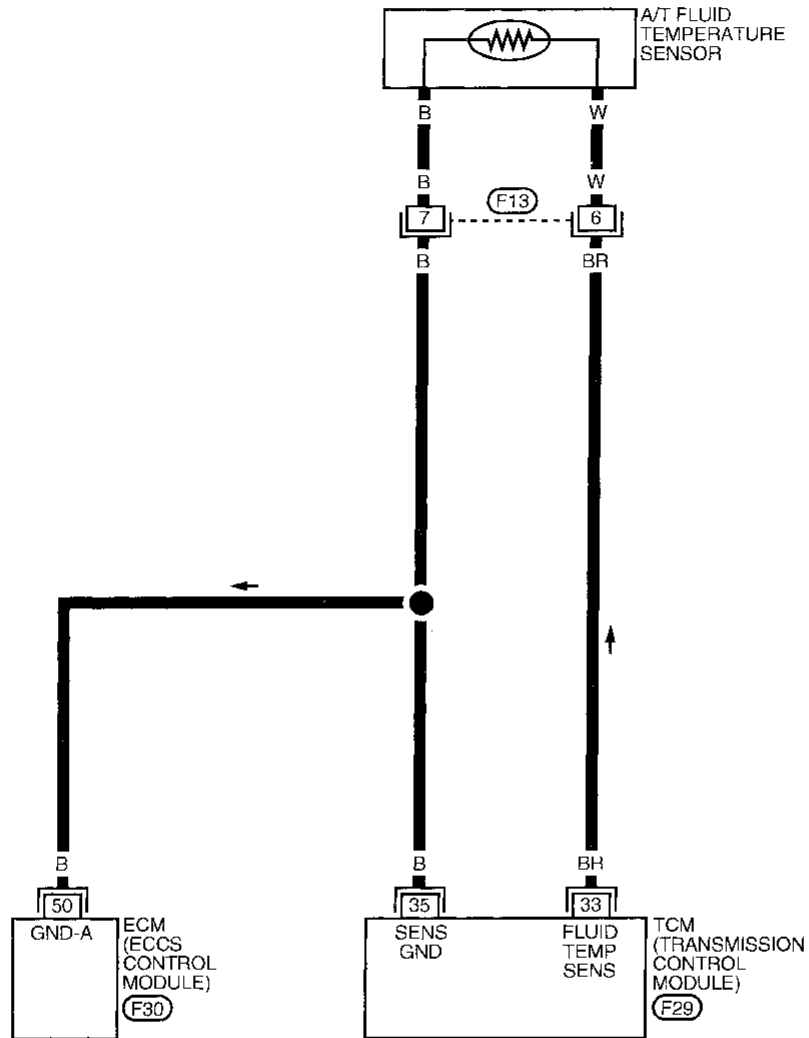

GI

MA

EM

LC

EC

FE

CL

MT

AT

FA

RA

BR

ST

RS

BT

HA

EL

IDX

TROUBLE DIAGNOSIS FOR DTC P0710

A/T Fluid Temperature Sensor (Cont'd)

DIAGNOSTIC PROCEDURE

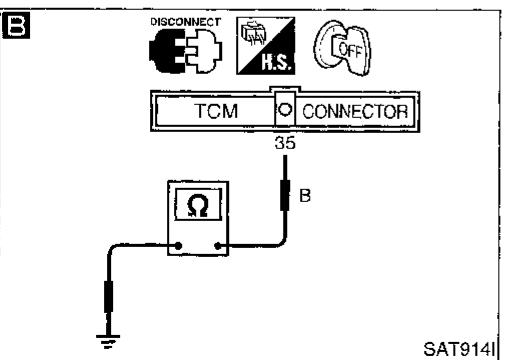
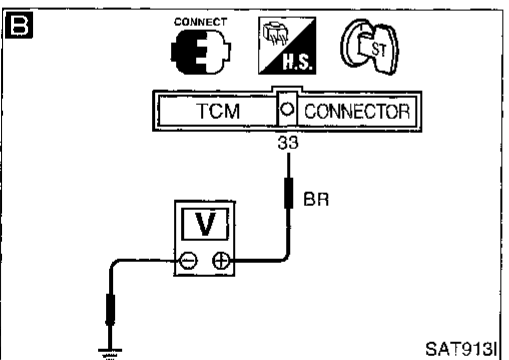
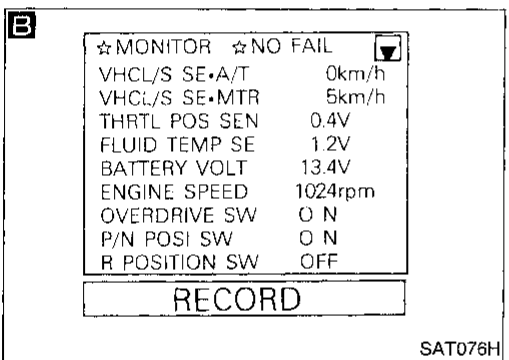
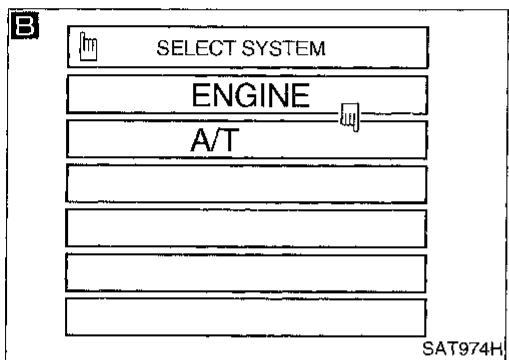
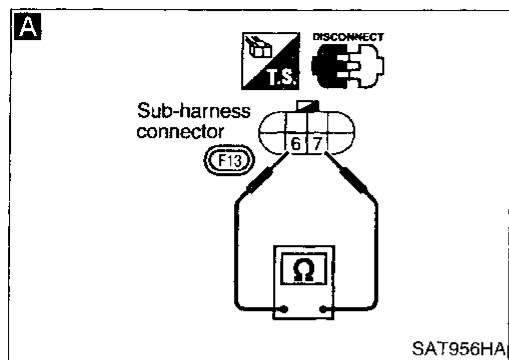

INSPECTION START

A

CHECK A/T FLUID TEMPERATURE SENSOR WITH TERMINAL CORD ASSEMBLY.

1. Turn ignition switch to "OFF" position.
2. Disconnect terminal cord assembly connector in engine compartment.
3. Check resistance between terminals ⑥ and ⑦ when A/T is cold.

Resistance:
Cold [20°C (68°F)]
Approximately 2.5 kΩ

4. Reinstall any part removed.

NG

1. Remove oil pan.
2. Check the following items:
 - A/T fluid temperature sensor
 - Refer to "Component Inspection", AT-85.
 - Harness of terminal cord assembly for short or open

OK

B

CHECK INPUT SIGNAL OF A/T FLUID TEMPERATURE SENSOR.

1. Start engine.
2. Select "ECU INPUT SIGNALS" in "DATA MONITOR" mode for "A/T" with CONSULT.
3. Read out the value of "FLUID TEMP SE".

Voltage:
Cold [20°C (68°F)] →
Hot [80°C (176°F)]:
Approximately 1.5V → 0.5V

OR

NG

Check the following item:

- Harness for short to ground or short to power or open between TCM, ECM and terminal cord assembly (Main harness)
- Ground circuit for ECM

Refer to EC section ("TROUBLE DIAGNOSIS FOR POWER SUPPLY").

1. Start engine.
2. Check voltage between TCM terminal ③③ and ground while warming up A/T.

Voltage:
Cold [20°C (68°F)] →
Hot [80°C (176°F)]:
Approximately 1.5V → 0.5V

3. Turn ignition switch to "OFF" position.
4. Disconnect TCM harness connector.
5. Check continuity between terminal ③⑤ and ground.

Continuity should exist.
If OK, check harness for short to ground and short to power.

OK

Perform Diagnostic Trouble Code (DTC) confirmation procedure, AT-82.

NG

1. Perform TCM input/output signal inspection.
2. If NG, recheck TCM pin terminals for damage or loose connection with harness connector.

OK

INSPECTION END

TROUBLE DIAGNOSIS FOR DTC P0710

A/T Fluid Temperature Sensor (Cont'd)

COMPONENT INSPECTION

A/T fluid temperature sensor

- For removal, refer to AT-204.
- Check resistance between two terminals while changing temperature as shown at left.

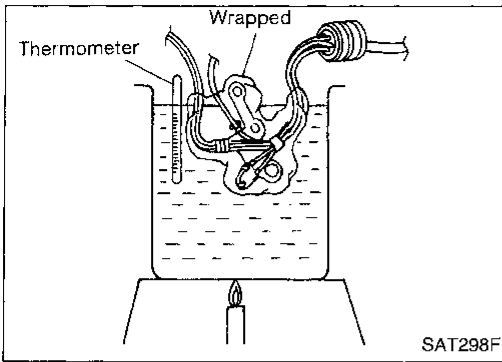

Temperature °C (°F)	Resistance
20 (68)	Approximately 2.5 kΩ
80 (176)	Approximately 0.3 kΩ

GI

MA

EM

LC

EC

FE

CL

MT

AT

FA

RA

BR

ST

RS

BT

HA

EL

IDX

TROUBLE DIAGNOSIS FOR DTC P0720

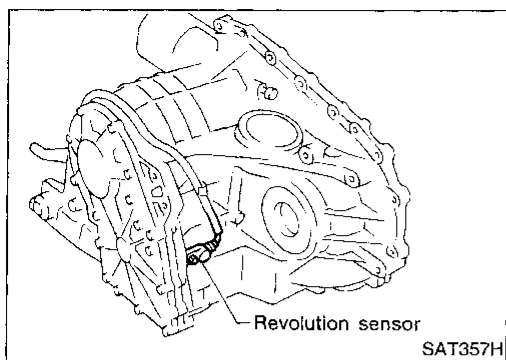

Vehicle Speed Sensor-A/T (Revolution sensor)

DESCRIPTION

The revolution sensor detects the revolution of the idler gear parking pawl lock gear and emits a pulse signal. The pulse signal is sent to the TCM which converts it into vehicle speed.

TCM TERMINALS AND REFERENCE VALUE

Remarks: Specification data are reference values.

Terminal No.	Wire color	Item	Condition		Judgement standard
25	L	Revolution sensor (Measure in AC range)		When vehicle cruises at 30 km/h (19 MPH).	1V or more Voltage rises gradually in response to vehicle speed.
				When vehicle parks.	0V
35	B	Throttle position sensor (Ground)		—	—

ON BOARD DIAGNOSIS LOGIC

Diagnostic trouble code	Malfunction is detected when ...	Check item (Possible cause)
: VEH SPD SEN/CIR AT : P0720 : MIL Code No. 1102	TCM does not receive the proper voltage signal from the sensor.	<ul style="list-style-type: none"> ● Harness or connectors (The sensor circuit is open or shorted.) ● Revolution sensor

TROUBLE DIAGNOSIS FOR DTC P0720

Vehicle Speed Sensor-A/T (Revolution sensor) (Cont'd)

DIAGNOSTIC TROUBLE CODE (DTC) CONFIRMATION PROCEDURE

CAUTION:

- Always drive vehicle at a safe speed.
- If conducting this "DTC CONFIRMATION PROCEDURE" again, always turn ignition switch "OFF" and wait at least 5 seconds before continuing.
- Be careful not to rev engine into the red zone on the tachometer.

After the repair, perform the following procedure to confirm the malfunction is eliminated.

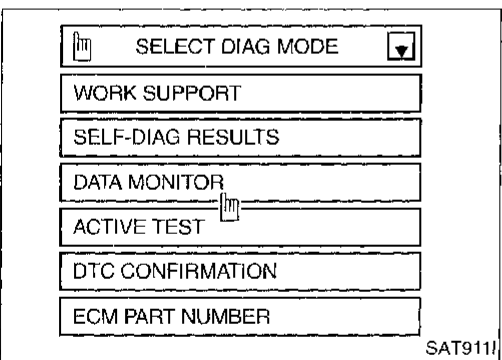
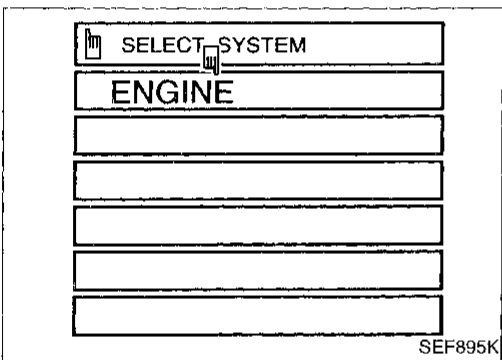
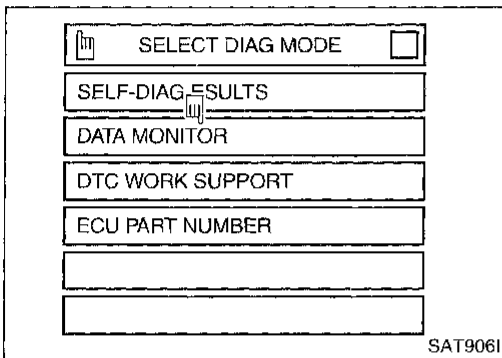
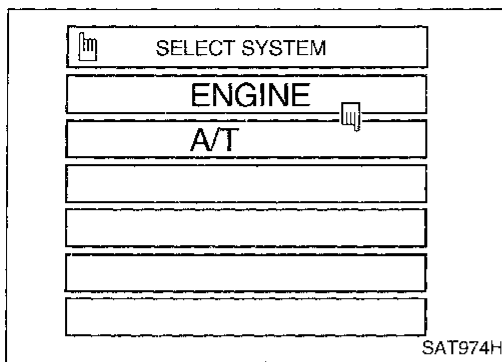

- 1) Turn ignition switch "ON" and select "DATA MONITOR" mode for "A/T" with CONSULT.
- 2) Drive vehicle and check for an increase of "VHCL/S SE-A/T" value in response to "VHCL/S SE-MTR" value increase.

If the check result is NG, go to "DIAGNOSTIC PROCEDURE", AT-168.

If the check result is OK, go to following step.

- 3) Select "DATA MONITOR" mode for "ENGINE" with CONSULT.
- 4) Start engine and maintain the following conditions for at least 5 consecutive seconds.

VHCL SPEED SE: 30 km/h (19 MPH) or more
THRTL POS SEN: More than 1.2V

Selector lever: D position (OD "ON")

Driving pattern: Driving the vehicle uphill (increased engine load) will help maintain the driving conditions required for this test.

If the check result is NG, go to "DIAGNOSTIC PROCEDURE", AT-89.

If the check result is OK, go to following step.

- 5) Maintain the following conditions for at least 5 consecutive seconds.

CMPS-RPM (REF): 3,500 rpm or more
THRTL POS SEN: More than 1.2V

Selector lever: D position (OD "ON")

Driving pattern: Driving the vehicle uphill (increased engine load) will help maintain the driving conditions required for this test.

OR

- 1) Start engine.
- 2) Drive vehicle under the following conditions:
 Selector lever in "D" (OD "ON"), vehicle speed higher than 30 km/h (19 MPH), throttle opening greater than 1/8 of the full throttle position and driving for more than 5 seconds.
- 3) Select "MODE 7" with GST.

OR

- 1) Start engine.
- 2) Drive vehicle under the following conditions:
 Selector lever in "D" (OD "ON"), vehicle speed higher than 30 km/h (19 MPH), throttle opening greater than 1/8 of the full throttle position and driving for more than 5 seconds.
- 3) Perform self-diagnosis for ECM.
 Refer to EC section ["Malfunction Indicator Lamp (MIL)", "ON BOARD DIAGNOSTIC SYSTEM DESCRIPTION"].

TROUBLE DIAGNOSIS FOR DTC P0720

Vehicle Speed Sensor-A/T (Revolution sensor) (Cont'd)

WIRING DIAGRAM — AT — VSSA/T

AT-VSSAT-01

— : Detectable line for DTC
 — : Non-detectable line for DTC

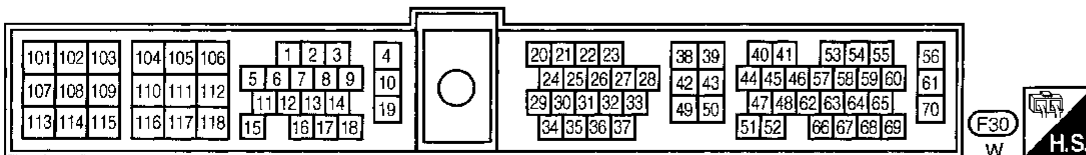
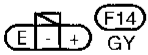
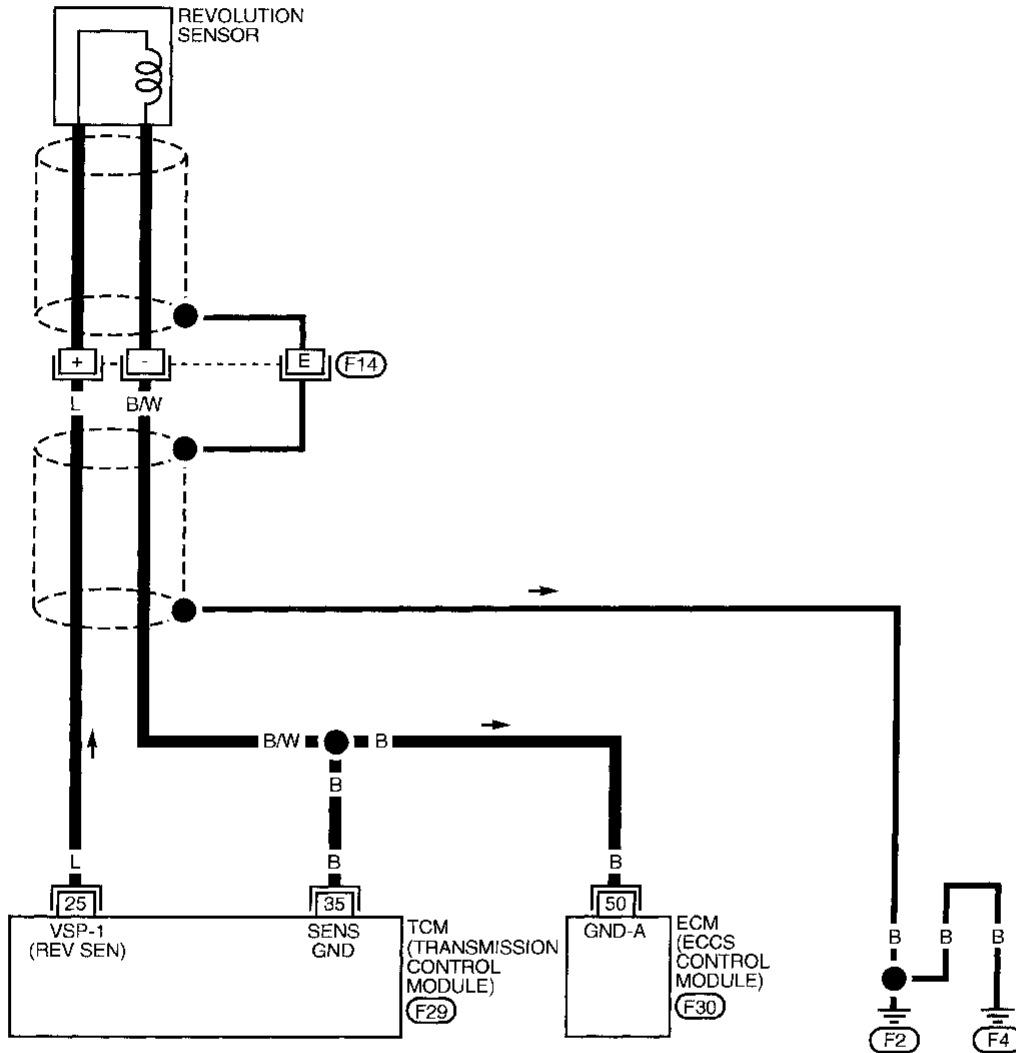

TROUBLE DIAGNOSIS FOR DTC P0720

Vehicle Speed Sensor-A/T (Revolution sensor) (Cont'd)

DIAGNOSTIC PROCEDURE

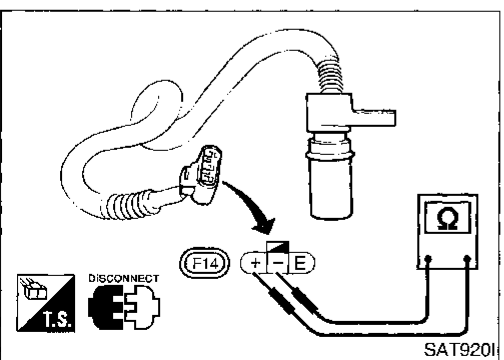
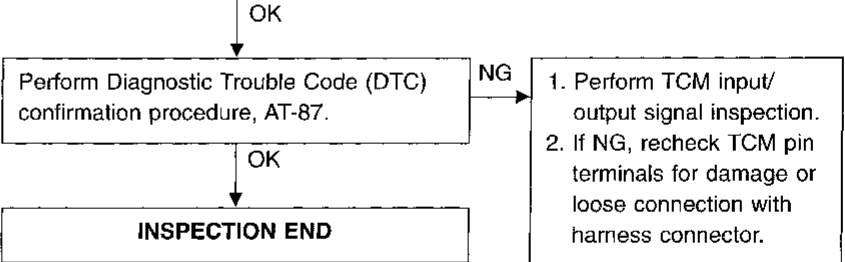
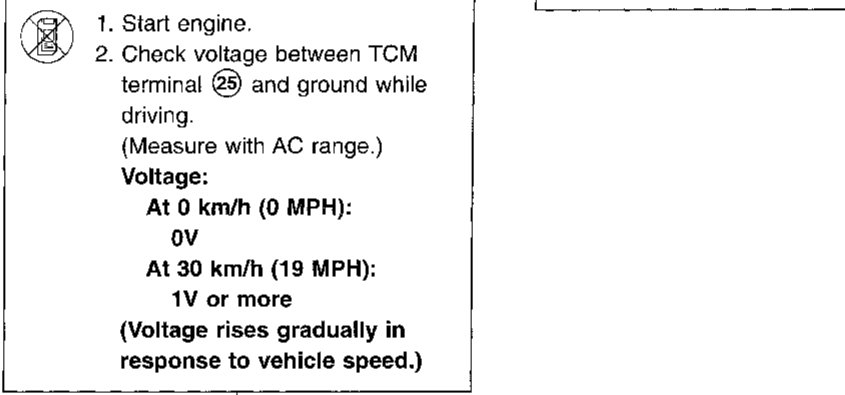
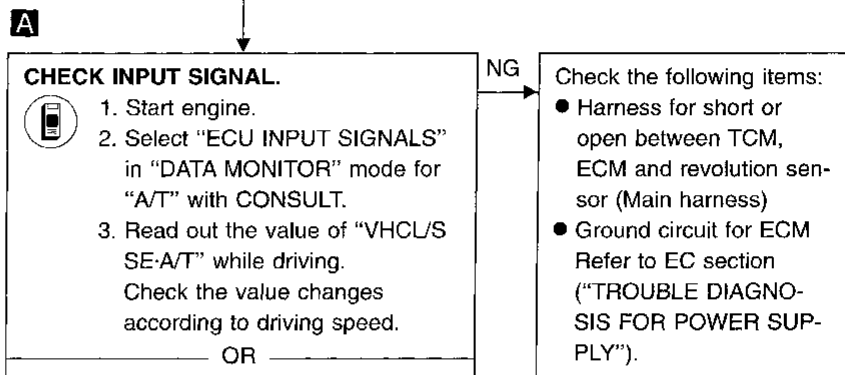
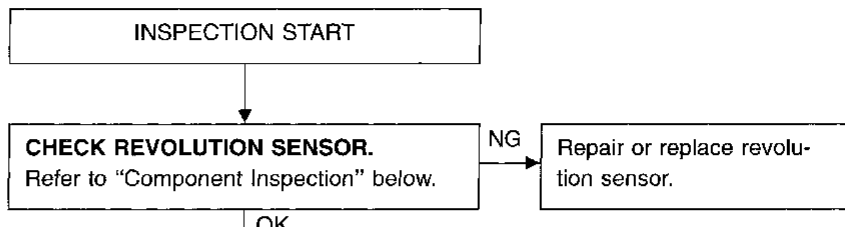
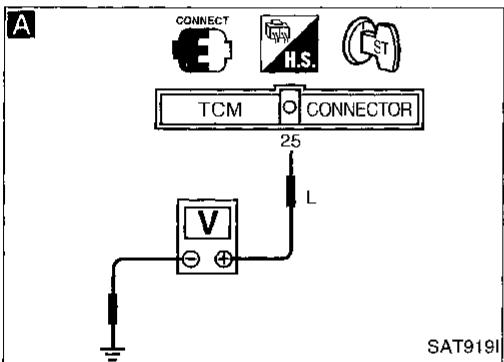
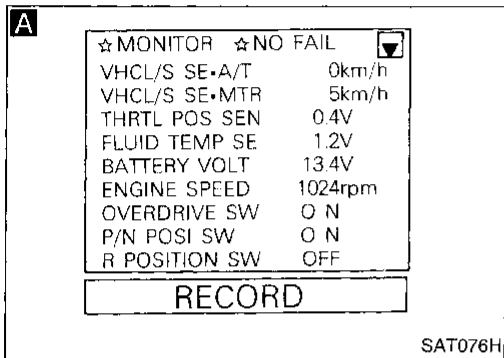
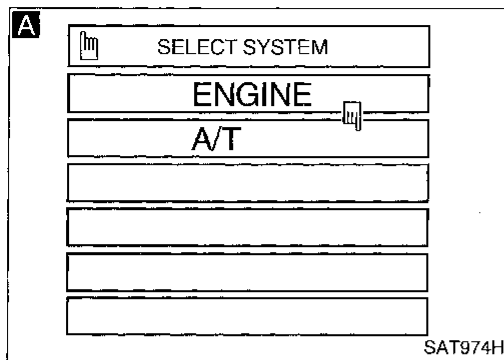

COMPONENT INSPECTION

Revolution sensor

- For removal, refer to AT-205.
- Check resistance between terminals ⊕ and ⊖.

Terminal No.		Resistance
⊕	⊖	500 - 650Ω

GI
MA
EM
LC
EC
FE
CL
MT
AT
FA
RA
BR
ST
RS
BT
HA
EL
DX

TROUBLE DIAGNOSIS FOR DTC P0725



Engine Speed Signal

DESCRIPTION



The engine speed signal is sent from the ECM to the TCM.

TCM TERMINALS AND REFERENCE VALUE

Remarks: Specification data are reference values.

Terminal No.	Wire color	Item	Condition	Judgement standard
24	L/OR	Engine speed signal	  When engine runs at idle speed.	0.5 - 1.5V

ON BOARD DIAGNOSIS LOGIC

Diagnostic trouble code	Malfunction is detected when ...	Check item (Possible cause)
 : ENGINE SPEED SIG  : P0725  : MIL Code No. 1207	TCM does not receive the proper voltage signal from ECM.	<ul style="list-style-type: none"> ● Harness or connectors (The sensor circuit is open or shorted.)

TROUBLE DIAGNOSIS FOR DTC P0725

Engine Speed Signal (Cont'd)

DIAGNOSTIC TROUBLE CODE (DTC) CONFIRMATION PROCEDURE

CAUTION:

- Always drive vehicle at a safe speed.
- If conducting this "DTC CONFIRMATION PROCEDURE" again, always turn ignition switch "OFF" and wait at least 5 seconds before continuing.

After the repair, perform the following procedure to confirm the malfunction is eliminated.

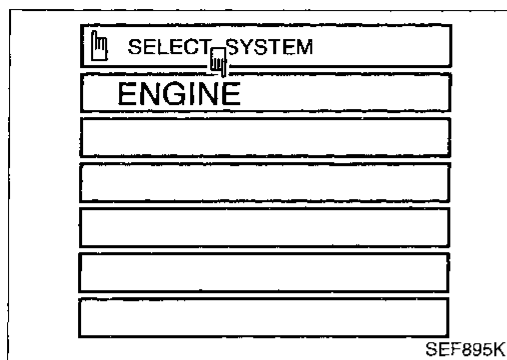

SEF895K

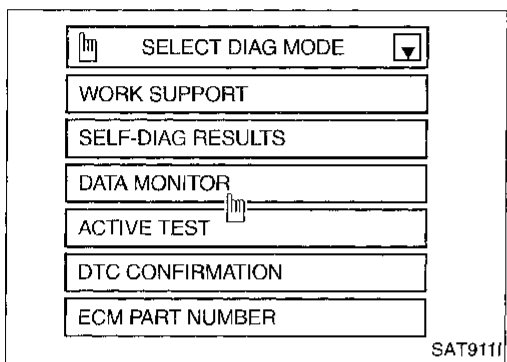

SAT911F

- 1) Turn ignition switch "ON" and select "DATA MONITOR" mode for "ENGINE" with CONSULT.

- 2) Start engine and maintain the following conditions for at least 10 consecutive seconds.

VHCL SPEED SE: 10 km/h (6 MPH) or more

THRTL POS SEN: More than 1.2V

Selector lever: D position (OD "ON")

OR

- 1) Start engine.
- 2) Drive vehicle under the following conditions: Selector lever in "D" (OD "ON"), vehicle speed higher than 10 km/h (6 MPH), throttle opening greater than 1/8 of the full throttle position and driving for more than 10 consecutive seconds.
- 3) Select "MODE 7" with GST.

OR

- 1) Start engine.
- 2) Drive vehicle under the following conditions: Selector lever in "D" (OD "ON"), vehicle speed higher than 10 km/h (6 MPH), throttle opening greater than 1/8 of the full throttle position and driving for more than 10 consecutive seconds.
- 3) Perform self-diagnosis for ECM. Refer to EC section ["Malfunction Indicator Lamp (MIL)", "ON BOARD DIAGNOSTIC SYSTEM DESCRIPTION"].

GI
MA
EM
LC
EC
FE
CL
MT
AT
FA
RA
BR
ST
RS
BT
HA
EL
IDX

TROUBLE DIAGNOSIS FOR DTC P0725

Engine Speed Signal (Cont'd) WIRING DIAGRAM — AT — ENGSS

AT-ENGSS-01

— : Detectable line for DTC
— : Non-detectable line for DTC

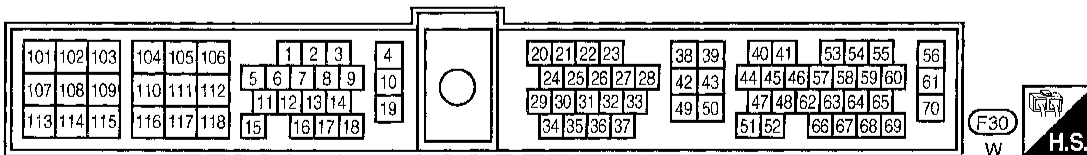
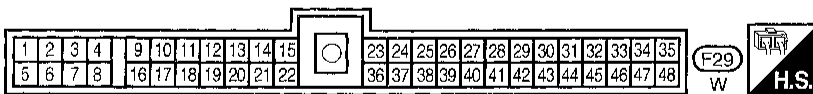
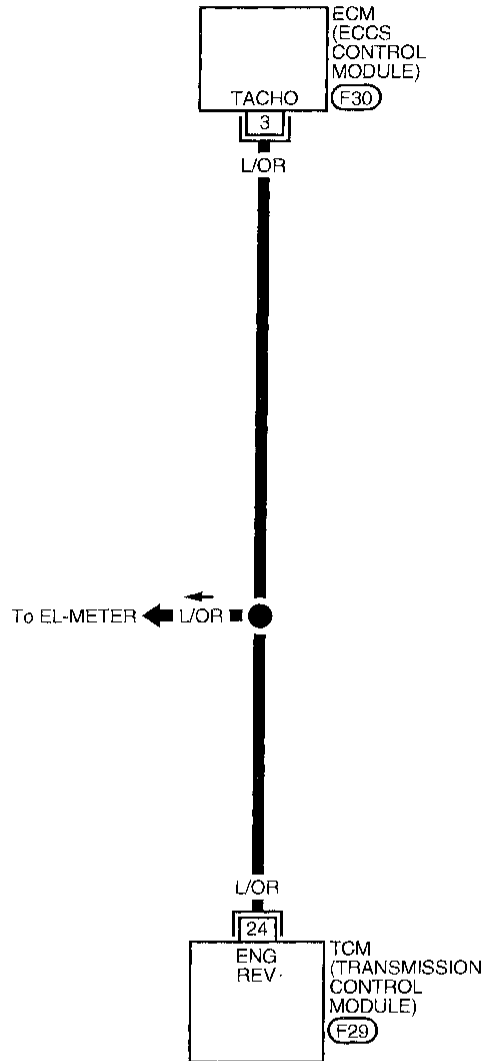

TROUBLE DIAGNOSIS FOR DTC P0725

Engine Speed Signal (Cont'd)

DIAGNOSTIC PROCEDURE

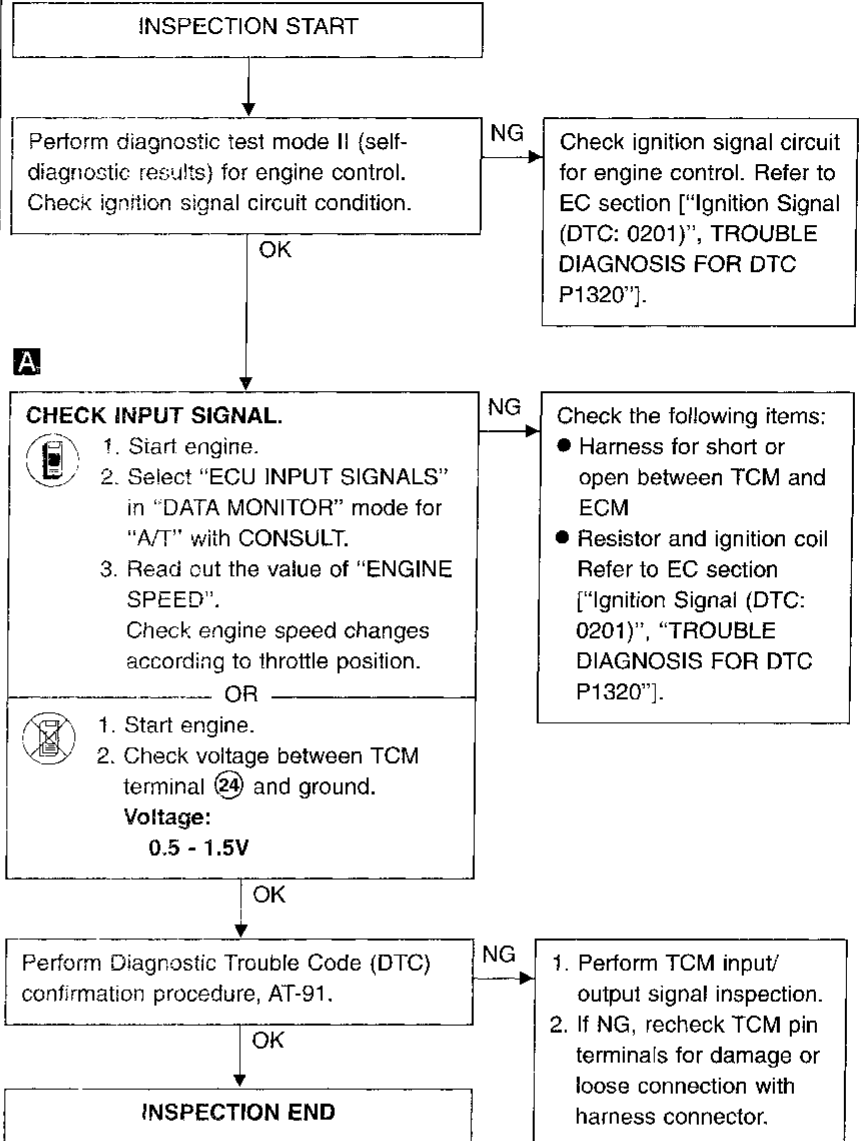
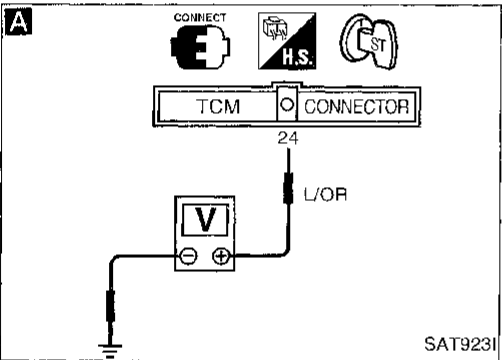
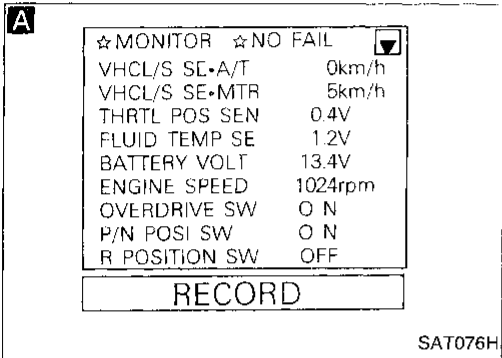
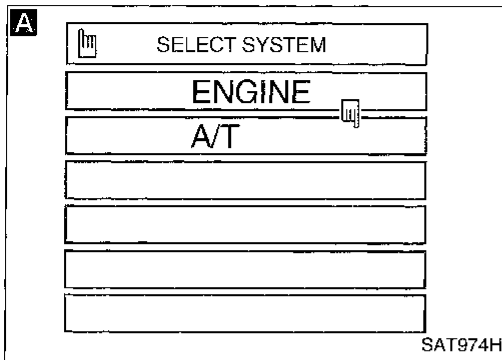

CI
MA
EM
LC
EC
FE
CL
MT
AT
FA
RA
BR
ST
RS
BT
HA
EL
DX

TROUBLE DIAGNOSIS FOR DTC P0731

A/T 1st Gear Function

DESCRIPTION

- This is an OBD-II self-diagnostic item and not available in TCM self-diagnosis.
- This malfunction will not be detected while the O/D OFF indicator lamp is indicating another self-diagnosis malfunction.
- This malfunction is detected when the A/T does not shift into first gear position as instructed by the TCM. This is not caused by electrical malfunction (circuits open or shorted) but by mechanical malfunction such as control valve sticking, improper solenoid valve operation, etc.

Gear position	1	2	3	4
Shift solenoid valve A	ON (Closed)	OFF (Open)	OFF (Open)	ON (Closed)
Shift solenoid valve B	ON (Closed)	ON (Closed)	OFF (Open)	OFF (Open)

TCM TERMINALS AND REFERENCE VALUE

Remarks: Specification data are reference values.

Terminal No.	Wire color	Item	Condition	Judgement standard
6	L/W	Shift solenoid valve A	When shift solenoid valve A operates. (When driving in "D ₁ " or "D ₄ ".)	Battery voltage
			When shift solenoid valve A does not operate. (When driving in "D ₂ " or "D ₃ ".)	1V or less
7	L/Y	Shift solenoid valve B	When shift solenoid valve B operates. (When driving in "D ₁ " or "D ₂ ".)	Battery voltage
			When shift solenoid valve B does not operate. (When driving in "D ₃ " or "D ₄ ".)	1V or less



ON BOARD DIAGNOSTIC LOGIC

This diagnosis monitors actual gear position by checking the torque converter slip ratio calculated by TCM as follows:

Torque converter slip ratio = A x C/B

A: Output shaft revolution signal from revolution sensor

B: Engine speed signal from ECM

C: Gear ratio determined as gear position which TCM supposes

If the actual gear position is higher than the position (1st) supposed by TCM, the slip ratio will be more than normal. In case the ratio exceeds the specified value, TCM judges this diagnosis malfunction.



This malfunction will be caused when either shift solenoid valve A is stuck open or shift solenoid valve B is stuck open.

TROUBLE DIAGNOSIS FOR DTC P0731

A/T 1st Gear Function (Cont'd)

Gear position supposed by TCM	1	2	3	4
In case of gear position with no malfunctions	1	2	3	4
In case of gear position with shift solenoid valve A stuck open	②	2	3	3
In case of gear position with shift solenoid valve B stuck open	④	3	3	4

○: P0731 is detected.

Diagnostic trouble code	Malfunction is detected when ...	Check item (Possible cause)
 : A/T 1ST GR FNCTN  : P0731  : MIL Code No. 1103	A/T cannot be shifted to the 1st gear position even if electrical circuit is good.	<ul style="list-style-type: none"> ● Shift solenoid valve A ● Shift solenoid valve B ● Each clutch ● Hydraulic control circuit

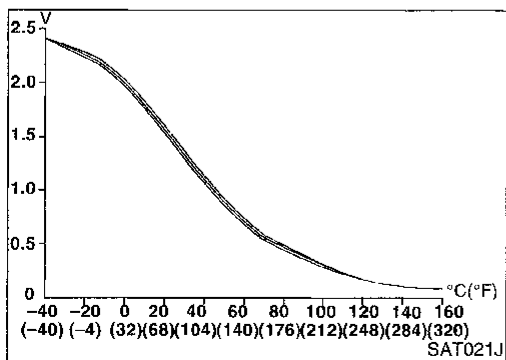
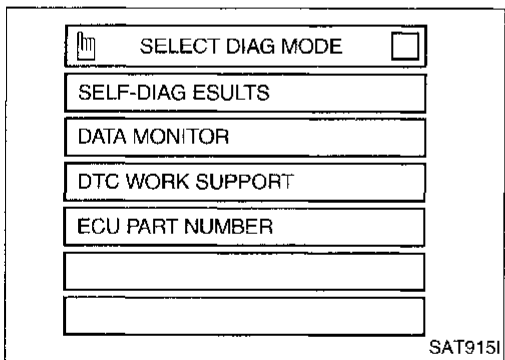
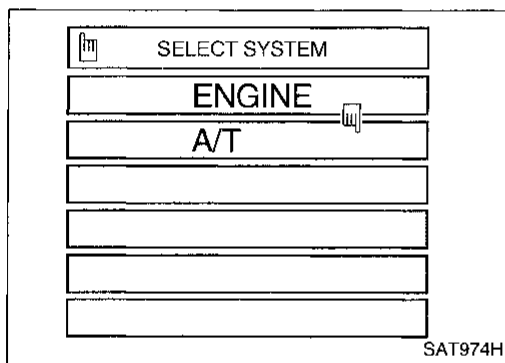

DIAGNOSTIC TROUBLE CODE (DTC) CONFIRMATION PROCEDURE

CAUTION:

- Always drive vehicle at a safe speed.
- If conducting this "DTC CONFIRMATION PROCEDURE" again, always turn ignition switch "OFF" and wait at least 5 seconds before continuing.
- Be careful not to rev engine into the red zone on the tachometer.

NOTE:

Always drive vehicle on a level road to improve the accuracy of test.

After the repair, perform the following procedure to confirm the malfunction is eliminated.

- 1) Start engine and select "DATA MONITOR" mode for "A/T" with CONSULT.
- 2) Make sure that output voltage of A/T fluid temperature sensor is within the range below.
FLUID TEMP SEN: 0.4 - 1.5V
 If out of range, drive the vehicle to decrease the voltage (warm up the fluid) or stop engine to increase the voltage (cool down the fluid).
- 3) Select "1ST GR FNCTN P0731" of "DTC WORK SUPPORT" mode for "A/T" with CONSULT and touch "START".
- 4) Accelerate vehicle to 20 to 25 km/h (12 to 16 MPH) under the following condition and release the accelerator pedal completely.
THROTTLE POSI: Less than 1/8
Selector lever: D position (OD "ON")
 - Check that "GEAR" shows "2" after releasing pedal.

TROUBLE DIAGNOSIS FOR DTC P0731

A/T 1st Gear Function (Cont'd)

- 5) Depress accelerator pedal to WOT (more than 7/8 of "THROTTLE POSI") quickly from a speed of 20 to 25 km/h (12 to 16 MPH) until "TESTING" changes to "STOP VEHICLE" or "COMPLETE". (It will take approximately 3 seconds.)
If the check result NG appears on CONSULT screen, go to "DIAGNOSTIC PROCEDURE", AT-99.
If "STOP VEHICLE" appears on CONSULT screen, go to the following step.
 - Check that "GEAR" shows "1" when depressing accelerator pedal to WOT.
 - If "TESTING" does not appear on CONSULT for a long time, select "SELF-DIAG RESULTS" for "ENGINE". In case a 1st trip DTC other than P0731 is shown, refer to applicable "TROUBLE DIAGNOSIS FOR DTC".
- 6) Stop vehicle.
- 7) Follow the instruction displayed. (Check for normal shifting referring to the table below.)

Vehicle condition	Gear on actual transmission shift pattern when screen is changed to 1 → 2 → 3 → 4
No malfunction exists	1 → 2 → 3 → 4
Malfunction for P0731 exists.	2 → 2 → 3 → 3
	4 → 3 → 3 → 4

- 8) Make sure that "OK" is displayed. (If "NG" is displayed, refer to "DIAGNOSTIC PROCEDURE".) Refer to "DIAGNOSTIC PROCEDURE", AT-99. Refer to shift schedule, AT-301.

OR



- 1) Start engine and warm up ATF.
- 2) Accelerate vehicle to 20 to 25 km/h (12 to 16 MPH) under the following condition and release the accelerator pedal completely.
THROTTLE POSI: Less than 1/8
Selector lever: D position (OD "ON")
Refer to shift schedule, AT-301.
- 3) Depress accelerator pedal to WOT (more than 7/8 of "THROTTLE POSI") quickly from a speed of 20 to 25 km/h (12 to 16 MPH). (It will take approximately 3 seconds.)
- 4) Select "MODE 7" with GST.

OR



- 1) Start engine and warm up ATF.
- 2) Accelerate vehicle to 20 to 25 km/h (12 to 16 MPH) under the following condition and release the accelerator pedal completely.
THROTTLE POSI: Less than 1/8
Selector lever: D position (OD "ON")
Refer to shift schedule, AT-301.
- 3) Depress accelerator pedal to WOT (more than 7/8 of "THROTTLE POSI") quickly from a speed of 20 to 25 km/h (12 to 16 MPH). (It will take approximately 3 seconds.)

TROUBLE DIAGNOSIS FOR DTC P0731

A/T 1st Gear Function (Cont'd)

- 4) Perform self-diagnosis for ECM.
Refer to EC section ["Malfunction Indicator Lamp (MIL)", "ON BOARD DIAGNOSTIC SYSTEM DESCRIPTION"].

GI

MA

EM

LC

EC

FE

CL

MT

AT

FA

RA

BR

ST

RS

BT

HA

EL

IDX

TROUBLE DIAGNOSIS FOR DTC P0731

A/T 1st Gear Function (Cont'd)

WIRING DIAGRAM — AT — 1ST

AT-1STSIG-01

: Detectable line for DTC
 : Non-detectable line for DTC

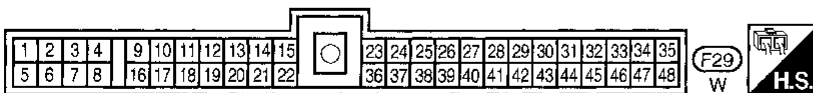
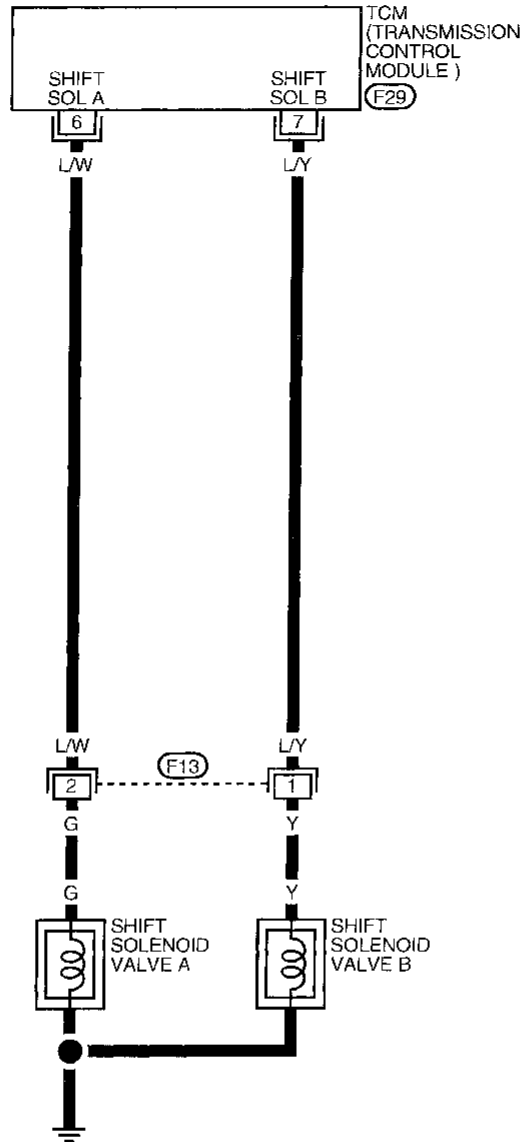

TROUBLE DIAGNOSIS FOR DTC P0731

A/T 1st Gear Function (Cont'd)

DIAGNOSTIC PROCEDURE

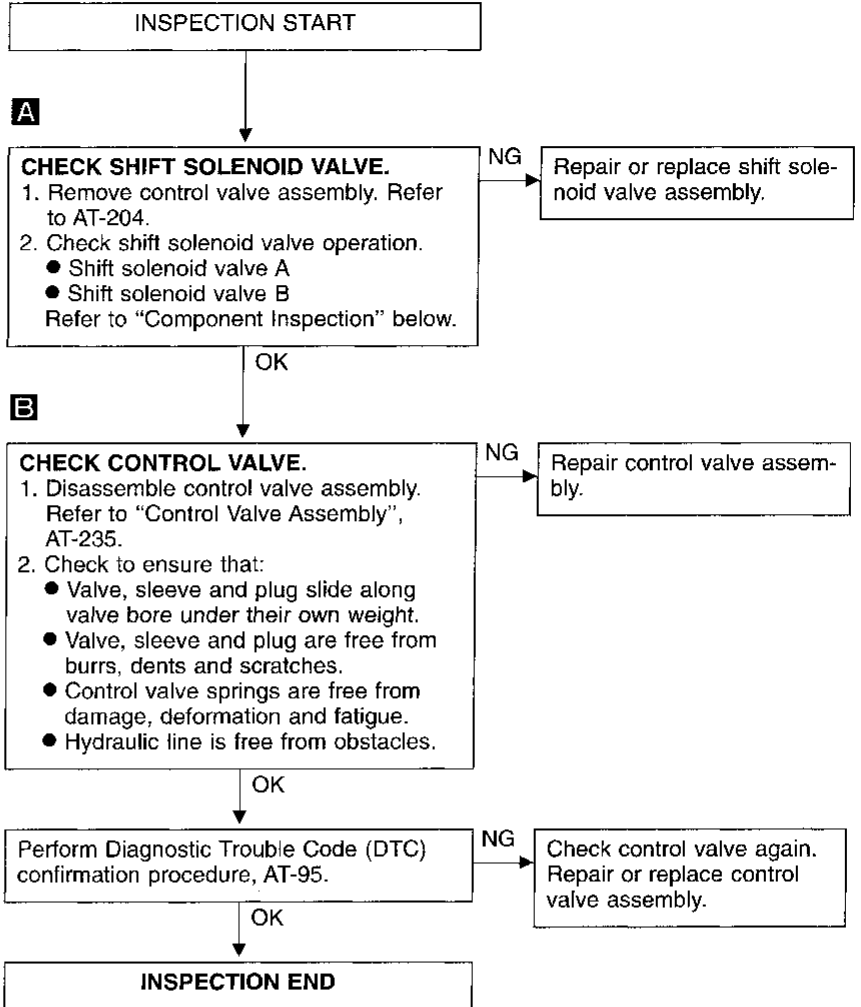
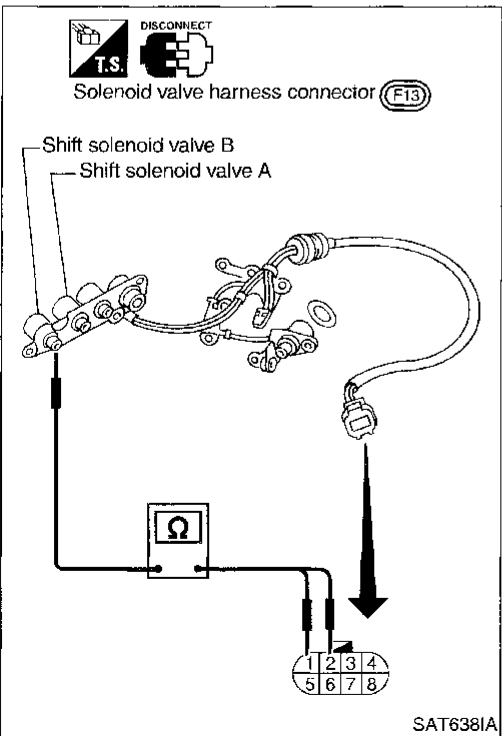
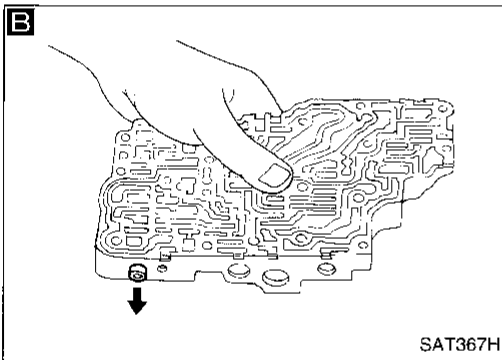
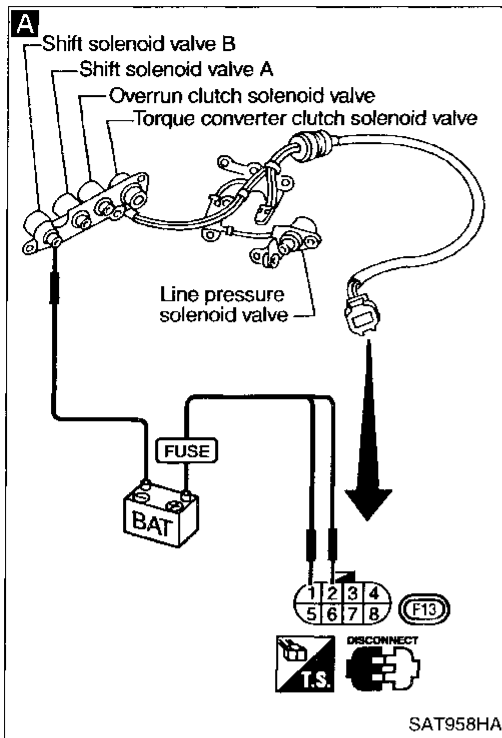

COMPONENT INSPECTION

Shift solenoid valve A and B

- For removal, refer to AT-204.

Resistance check

- Check resistance between two terminals.

Solenoid valve	Terminal No.	Resistance (Approx.)
Shift solenoid valve A	②	Ground 20 - 40Ω
Shift solenoid valve B	①	

TROUBLE DIAGNOSIS FOR DTC P0731

A/T 1st Gear Function (Cont'd)

Operation check

- Check solenoid valve by listening for its operating sound while applying battery voltage to the terminal and ground.

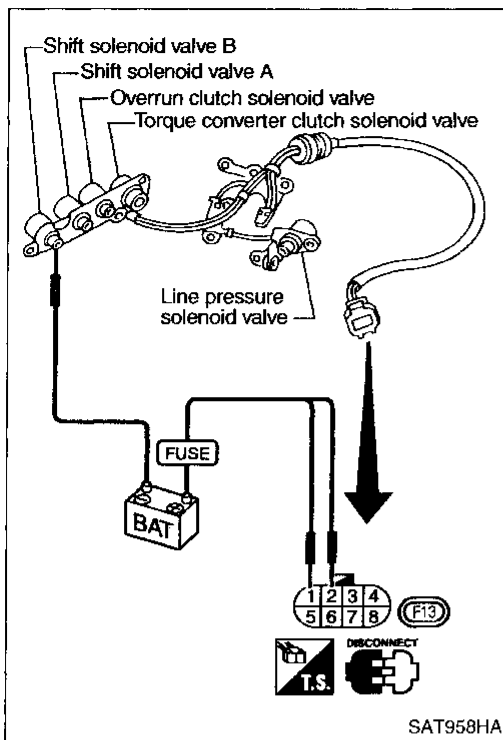

TROUBLE DIAGNOSIS FOR DTC P0732

A/T 2nd Gear Function

DESCRIPTION

- This is an OBD-II self-diagnostic item and not available in TCM self-diagnosis.
- This malfunction will not be detected while the O/D OFF indicator lamp is indicating another self-diagnosis malfunction.
- This malfunction is detected when the A/T does not shift into second gear position as instructed by the TCM. This is not caused by electrical malfunction (circuits open or shorted) but by mechanical malfunction such as control valve sticking, improper solenoid valve operation, etc.

Gear position	1	2	3	4
Shift solenoid valve A	ON (Closed)	OFF (Open)	OFF (Open)	ON (Closed)
Shift solenoid valve B	ON (Closed)	ON (Closed)	OFF (Open)	OFF (Open)

TCM TERMINALS AND REFERENCE VALUE

Remarks: Specification data are reference values.

Terminal No.	Wire color	Item	Condition	Judgement standard
7	L/Y	Shift solenoid valve B	 When shift solenoid valve B operates. (When driving in "D ₁ " or "D ₂ ".)	Battery voltage
			When shift solenoid valve B does not operate. (When driving in "D ₃ " or "D ₄ ".)	1V or less

ON BOARD DIAGNOSTIC LOGIC

This diagnosis monitors actual gear position by checking the torque converter slip ratio calculated by TCM as follows:

$$\text{Torque converter slip ratio} = A \times C/B$$

A: Output shaft revolution signal from revolution sensor

B: Engine speed signal from ECM



C: Gear ratio determined as gear position which TCM supposes

If the actual gear position is higher than the position (2nd) supposed by TCM, the slip ratio will be more than normal. In case the ratio exceeds the specified value, TCM judges this diagnosis malfunction.

This malfunction will be caused when shift solenoid valve B is stuck open.

Gear position supposed by TCM	1	2	3	4
In case of gear position with no malfunctions	1	2	3	4
In case of gear position with shift solenoid valve B stuck open	4	③	3	4

○: P0732 is detected.

Diagnostic trouble code	Malfunction is detected when ...	Check item (Possible cause)
 : A/T 2ND GR FNCTN  : P0732  : MIL Code No. 1104	A/T cannot be shifted to the 2nd gear position even if electrical circuit is good.	<ul style="list-style-type: none"> ● Shift solenoid valve B ● Each clutch ● Hydraulic control circuit

TROUBLE DIAGNOSIS FOR DTC P0732

A/T 2nd Gear Function (Cont'd)

DIAGNOSTIC TROUBLE CODE (DTC) CONFIRMATION PROCEDURE

CAUTION:

- Always drive vehicle at a safe speed.
- If conducting this "DTC CONFIRMATION PROCEDURE" again, always turn ignition switch "OFF" and wait at least 5 seconds before continuing.
- Be careful not to rev engine into the red zone on the tachometer.

NOTE:

Always drive vehicle on a level road to improve the accuracy of test.

After the repair, perform the following procedure to confirm the malfunction is eliminated.

- 1) Start engine and select "DATA MONITOR" mode for "A/T" with CONSULT.

- 2) Make sure that output voltage of A/T fluid temperature sensor is within the range below.
FLUID TEMP SEN: 0.4 - 1.5V

If out of range, drive the vehicle to decrease the voltage (warm up the fluid) or stop engine to increase the voltage (cool down the fluid).

- 3) Select "2ND GR FNCTN P0732" of "DTC WORK SUPPORT" mode for "A/T" with CONSULT and touch "START".

- 4) Accelerate vehicle to 60 to 65 km/h (37 to 40 MPH) under the following condition and release the accelerator pedal completely.

THROTTLE POSI: Less than 1/8

Selector lever: D position (OD "ON")

- Check that "GEAR" shows "3" or "4" after releasing pedal.
- 5) Depress accelerator pedal to WOT (more than 7/8 of "THROTTLE POSI") quickly from a speed of 60 to 65 km/h (37 to 40 MPH) until "TESTING" changes to "STOP VEHICLE" or "COMPLETE". (It will take approximately 3 seconds.)

If the check result NG appears on CONSULT screen, go to "DIAGNOSTIC PROCEDURE", AT-105.

If "STOP VEHICLE" appears on CONSULT screen, go to following step.

- Check that "GEAR" shows "2" when depressing accelerator pedal to WOT.
 - If "TESTING" does not appear on CONSULT for a long time, select "SELF-DIAG RESULTS" for "ENGINE". In case a 1st trip DTC other than P0732 is shown, refer to applicable "TROUBLE DIAGNOSIS FOR DTC".
- 6) Stop vehicle.
 - 7) Follow the instruction displayed. (Check for normal shifting referring to the table below.)

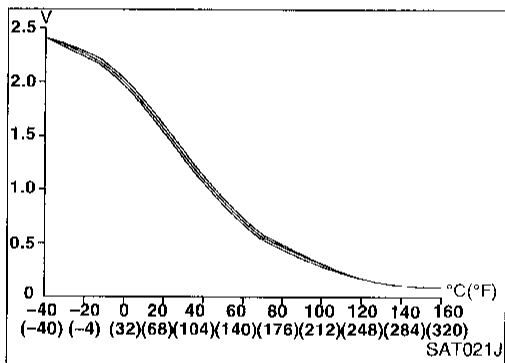
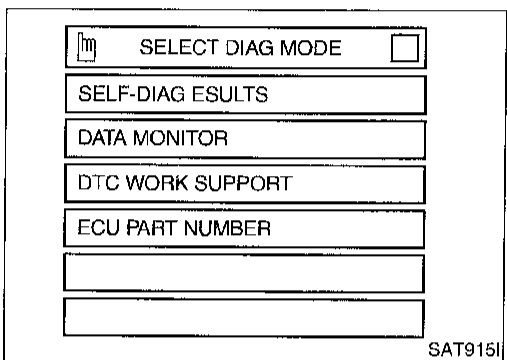
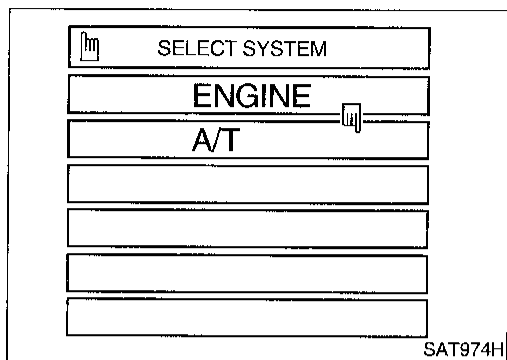

Vehicle condition	Gear on actual transmission shift pattern when screen is changed to 1 → 2 → 3 → 4
No malfunction exists	1 → 2 → 3 → 4
Malfunction for P0732 exists.	4 → 3 → 3 → 4

TROUBLE DIAGNOSIS FOR DTC P0732

A/T 2nd Gear Function (Cont'd)

- 8) Make sure that "OK" is displayed. (If "NG" is displayed, refer to "DIAGNOSTIC PROCEDURE".)
Refer to "DIAGNOSTIC PROCEDURE", AT-105.
Refer to shift schedule, AT-301.

GI

OR



- 1) Start engine and warm up ATF.
2) Accelerate vehicle to 60 to 65 km/h (37 to 40 MPH) under the following condition and release the accelerator pedal completely.

MA

EM

THROTTLE POSI: Less than 1/8

Selector lever: D position (OD "ON")

Refer to shift schedule, AT-301.

LC

- 3) Depress accelerator pedal to WOT (more than 7/8 of "THROTTLE POSI") quickly from a speed of 60 to 65 km/h (37 to 40 MPH). (It will take approximately 3 seconds.)

EC

- 4) Select "MODE 7" with GST.

OR



- 1) Start engine and warm up ATF.
2) Accelerate vehicle to 60 to 65 km/h (37 to 40 MPH) under the following condition and release the accelerator pedal completely.

FE

CL

THROTTLE POSI: Less than 1/8

Selector lever: D position (OD "ON")

Refer to shift schedule, AT-301.

MT

- 3) Depress accelerator pedal to WOT (more than 7/8 of "THROTTLE POSI") quickly from a speed of 60 to 65 km/h (37 to 40 MPH). (It will take approximately 3 seconds.)

AT

- 4) Perform self-diagnosis for ECM.
Refer to EC section ["Malfunction Indicator Lamp (MIL)", "ON BOARD DIAGNOSTIC SYSTEM DESCRIPTION"].

FA

RA

BR

ST

RS

BT

HA

EL

IDX

TROUBLE DIAGNOSIS FOR DTC P0732

A/T 2nd Gear Function (Cont'd)

WIRING DIAGRAM — AT — 2ND

AT-2NDSIG-01

— : Detectable line for DTC
 — : Non-detectable line for DTC

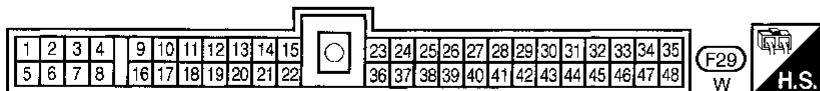
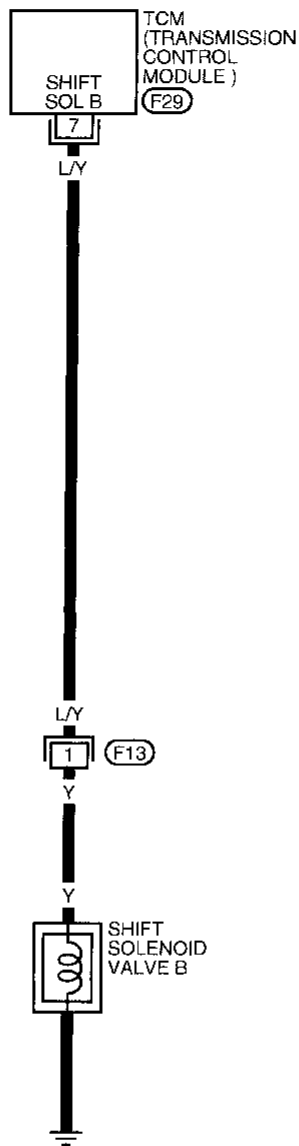

TROUBLE DIAGNOSIS FOR DTC P0732

A/T 2nd Gear Function (Cont'd)

DIAGNOSTIC PROCEDURE

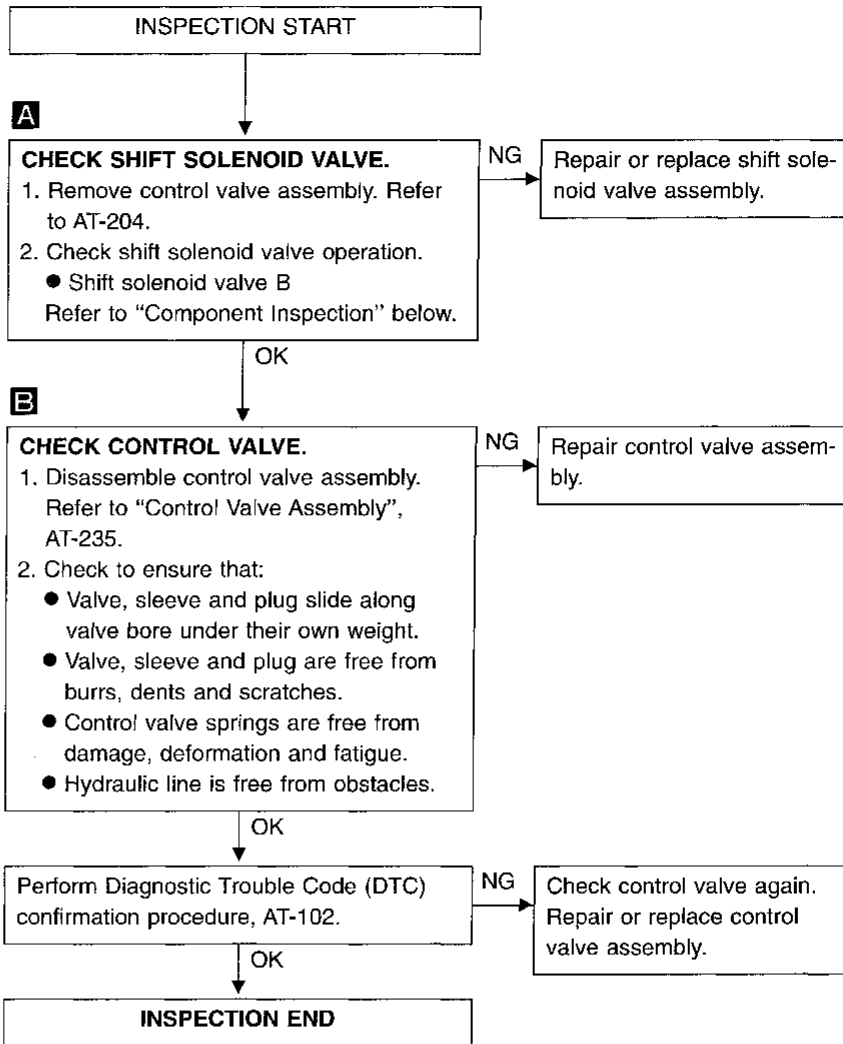
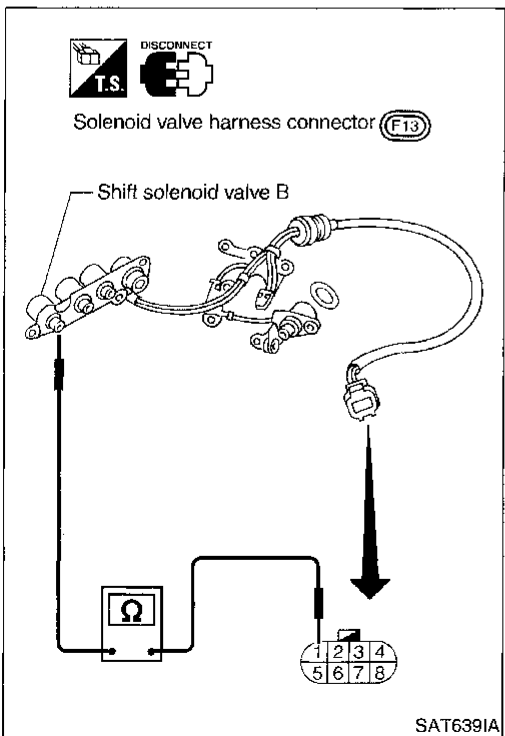
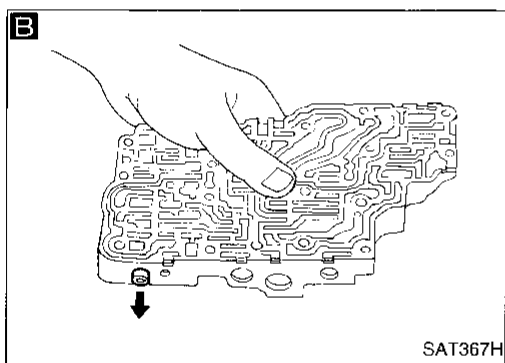
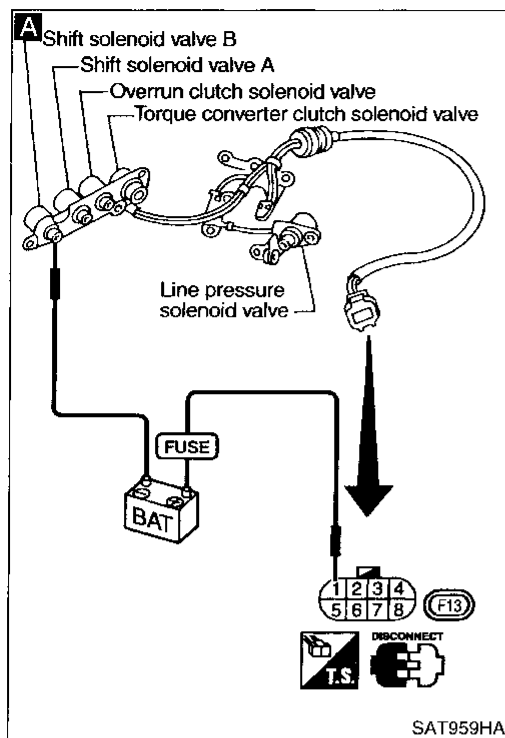

COMPONENT INSPECTION

Shift solenoid valve B

- For removal, refer to AT-204.

Resistance check

- Check resistance between two terminals.

Solenoid valve	Terminal No.		Resistance (Approx.)
Shift solenoid valve B	①	Ground	20 - 40Ω

TROUBLE DIAGNOSIS FOR DTC P0732

A/T 2nd Gear Function (Cont'd)

Operation check

- Check solenoid valve by listening for its operating sound while applying battery voltage to the terminal and ground.

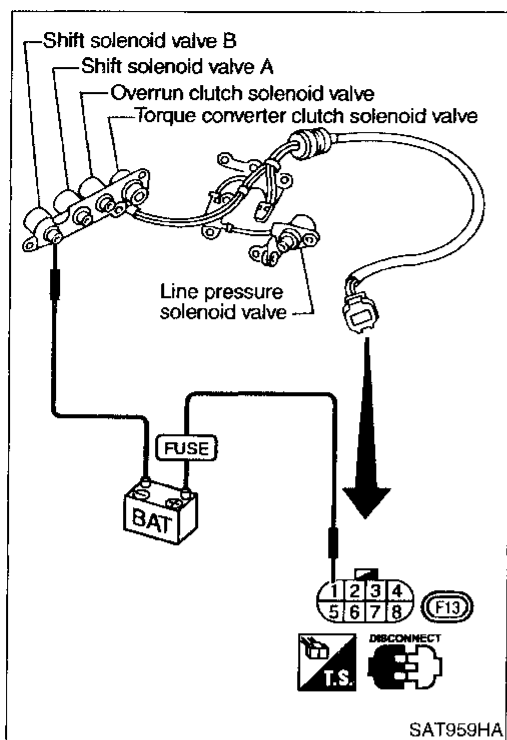

TROUBLE DIAGNOSIS FOR DTC P0733

A/T 3rd Gear Function

DESCRIPTION

- This is an OBD-II self-diagnostic item and not available in TCM self-diagnosis.
- This malfunction will not be detected while the O/D OFF indicator lamp is indicating another self-diagnosis malfunction.
- This malfunction is detected when the A/T does not shift into third gear position as instructed by the TCM. This is not caused by electrical malfunction (circuits open or shorted) but by mechanical malfunction such as control valve sticking, improper solenoid valve operation, malfunctioning servo piston or brake band, etc.

Gear position	1	2	3	4
Shift solenoid valve A	ON (Closed)	OFF (Open)	OFF (Open)	ON (Closed)
Shift solenoid valve B	ON (Closed)	ON (Closed)	OFF (Open)	OFF (Open)

TCM TERMINALS AND REFERENCE VALUE

Remarks: Specification data are reference values.

Terminal No.	Wire color	Item	Condition	Judgement standard
6	L/W	Shift solenoid valve A	 When shift solenoid valve A operates. (When driving in "D ₁ " or "D ₄ ".)	Battery voltage
			When shift solenoid valve A does not operate. (When driving in "D ₂ " or "D ₃ ".)	1V or less

ON BOARD DIAGNOSTIC LOGIC

This diagnosis monitors actual gear position by checking the torque converter slip ratio calculated by TCM as follows:

Torque converter slip ratio = A x C/B

A: Output shaft revolution signal from revolution sensor

B: Engine speed signal from ECM



C: Gear ratio determined as gear position which TCM supposes

If the actual gear position is higher than the position (3rd) supposed by TCM, the slip ratio will be more than normal. In case the ratio exceeds the specified value, TCM judges this diagnosis malfunction.

This malfunction will be caused when shift solenoid valve A is stuck closed.

Gear position supposed by TCM	1	2	3	4
In case of gear position with no malfunctions	1	2	3	4
In case of gear position with shift solenoid valve A stuck closed	1	1	④	4

○: P0733 is detected.

Diagnostic trouble code	Malfunction is detected when ...	Check item (Possible cause)
 : A/T 3RD GR FNCTN  : P0733  : MIL Code No. 1105	A/T cannot be shifted to the 3rd gear position even if electrical circuit is good.	<ul style="list-style-type: none"> • Shift solenoid valve A • Each clutch • Hydraulic control circuit

TROUBLE DIAGNOSIS FOR DTC P0733

A/T 3rd Gear Function (Cont'd)

DIAGNOSTIC TROUBLE CODE (DTC) CONFIRMATION PROCEDURE

CAUTION:

- Always drive vehicle at a safe speed.
- If conducting this "DTC CONFIRMATION PROCEDURE" again, always turn ignition switch "OFF" and wait at least 5 seconds before continuing.
- Be careful not to rev engine into the red zone on the tachometer.

NOTE:

Always drive vehicle on a level road to improve the accuracy of test.

After the repair, perform the following procedure to confirm the malfunction is eliminated.

- 1) Start engine and select "DATA MONITOR" mode for "A/T" with CONSULT.
- 2) Make sure that output voltage of A/T fluid temperature sensor is within the range below.
FLUID TEMP SEN: 0.4 - 1.5V
If out of range, drive the vehicle to decrease the voltage (warm up the fluid) or stop engine to increase the voltage (cool down the fluid).
- 3) Select "3RD GR FNCTN P0733" of "DTC WORK SUPPORT" mode for "A/T" with CONSULT and touch "START".
- 4) Accelerate vehicle to 65 to 80 km/h (40 to 50 MPH) under the following condition and release the accelerator pedal completely.
THROTTLE POSI: Less than 1/8
Selector lever: D position (OD "ON")
 - Check that "GEAR" shows "4" after releasing pedal.
- 5) Depress accelerator pedal with 3.5/8 - 4.5/8 of "THROTTLE POSI" from a speed of 65 to 80 km/h (40 to 50 MPH) until "TESTING" changes to "STOP VEHICLE" or "COMPLETE". (It will take approximately 3 seconds.)
If the check result NG appears on CONSULT screen, go to "DIAGNOSTIC PROCEDURE", AT-111.
If "STOP VEHICLE" appears on CONSULT screen, go to following step.
 - Check that "GEAR" shows "3" when depressing accelerator pedal with 3.5/8 - 4.5/8 of "THROTTLE POSI".
 - If "TESTING" does not appear on CONSULT for a long time, select "SELF-DIAG RESULTS" for "ENGINE". In case a 1st trip DTC other than P0733 is shown, refer to applicable "TROUBLE DIAGNOSIS FOR DTC".
- 6) Stop vehicle.
- 7) Follow the instruction displayed. (Check for normal shifting referring to the table below.)

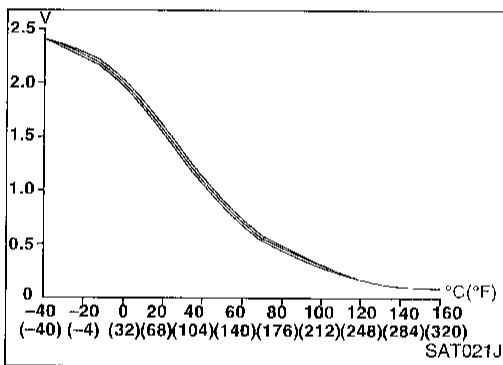
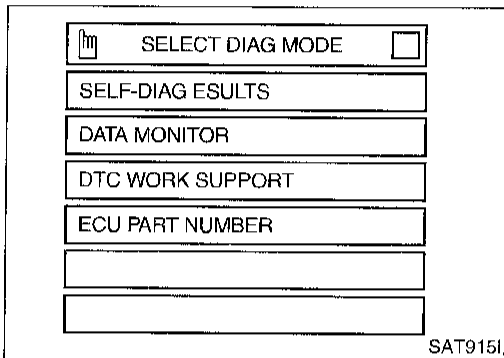
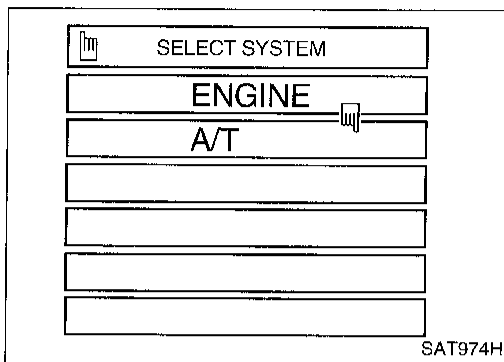

Vehicle condition	Gear on actual transmission shift pattern when screen is changed to 1 → 2 → 3 → 4
No malfunction exists.	1 → 2 → 3 → 4
Malfunction for P0733 exists.	1 → 1 → 4 → 4

TROUBLE DIAGNOSIS FOR DTC P0733

A/T 3rd Gear Function (Cont'd)

- 8) Make sure that "OK" is displayed. (If "NG" is displayed, refer to "DIAGNOSTIC PROCEDURE".)
Refer to "DIAGNOSTIC PROCEDURE", AT-111.
Refer to shift schedule, AT-301.

GI

OR



- 1) Start engine and warm up ATF.
2) Accelerate vehicle to 65 to 80 km/h (40 to 50 MPH) under the following condition and release the accelerator pedal completely.

MA

EM

THROTTLE POSI: Less than 1/8

Selector lever: D position (OD "ON")

Refer to shift schedule, AT-301.

LC

- 3) Depress accelerator pedal with 3.5/8 - 4.5/8 of "THROTTLE POSI" from a speed of 65 to 80 km/h (40 to 50 MPH). (It will take approximately 3 seconds.)

EC

- 4) Select "MODE 7" with GST.

OR



- 1) Start engine and warm up ATF.
2) Accelerate vehicle to 65 to 80 km/h (40 to 50 MPH) under the following condition and release the accelerator pedal completely.

FE

CL

THROTTLE POSI: Less than 1/8

Selector lever: D position (OD "ON")

Refer to shift schedule, AT-301.

MT

- 3) Depress accelerator pedal with 3.5/8 - 4.5/8 of "THROTTLE POSI" from a speed of 65 to 80 km/h (40 to 50 MPH). (It will take approximately 3 seconds.)

AT

- 4) Perform self-diagnosis for ECM.
Refer to EC section ["Malfunction Indicator Lamp (MIL)", "ON BOARD DIAGNOSTIC SYSTEM DESCRIPTION"].

FA

RA

BR

ST

RS

BT

HA

EL

IDX

TROUBLE DIAGNOSIS FOR DTC P0733

A/T 3rd Gear Function (Cont'd)

WIRING DIAGRAM — AT — 3RD

AT-3RDSIG-01

— : Detectable line for DTC
 — : Non-detectable line for DTC

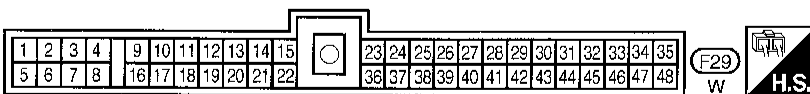
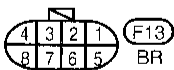
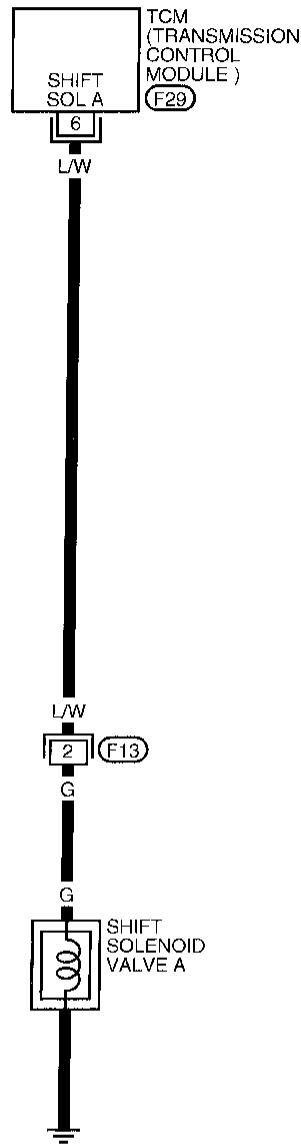

TROUBLE DIAGNOSIS FOR DTC P0733

A/T 3rd Gear Function (Cont'd)

DIAGNOSTIC PROCEDURE

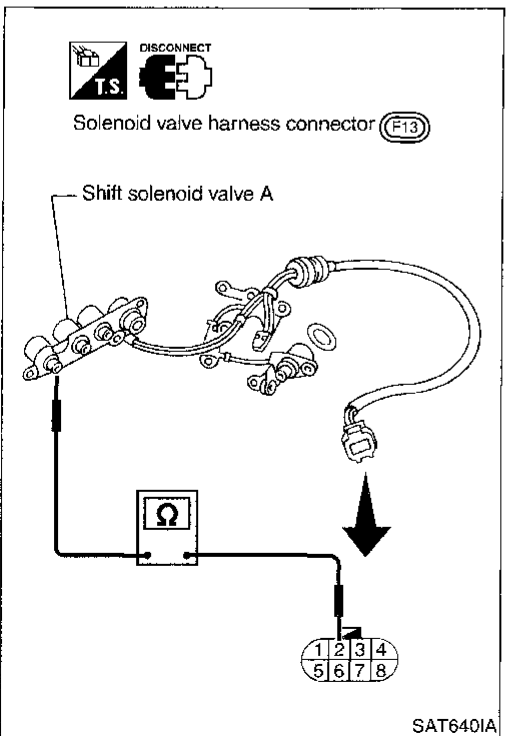
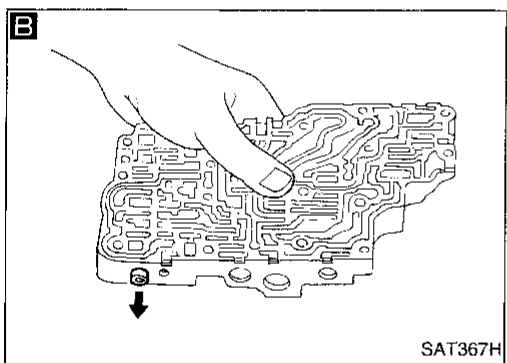
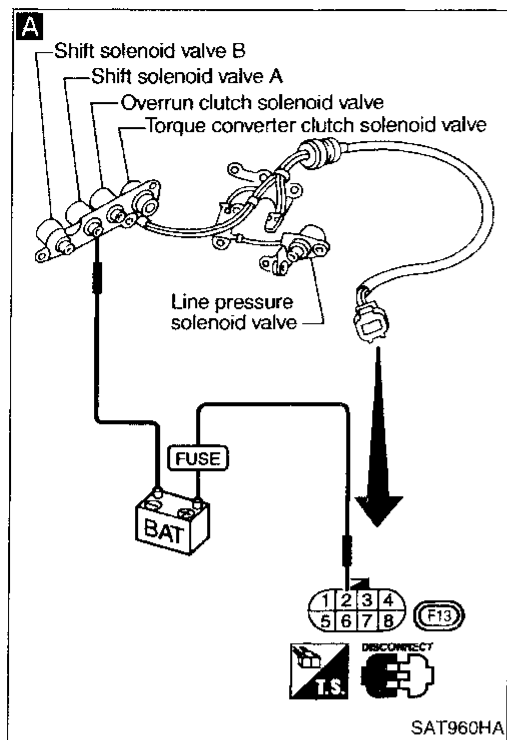

INSPECTION START

A
CHECK SHIFT SOLENOID VALVE.
 1. Remove control valve assembly. Refer to AT-204.
 2. Check shift solenoid valve operation.
 ● Shift solenoid valve A
 Refer to "Component Inspection" below.

NG → Repair or replace shift solenoid valve assembly.

B
CHECK CONTROL VALVE.
 1. Disassemble control valve assembly. Refer to "Control Valve Assembly", AT-235.
 2. Check to ensure that:
 ● Valve, sleeve and plug slide along valve bore under their own weight.
 ● Valve, sleeve and plug are free from burrs, dents and scratches.
 ● Control valve springs are free from damage, deformation and fatigue.
 ● Hydraulic line is free from obstacles.

NG → Repair control valve assembly.

Perform Diagnostic Trouble Code (DTC) confirmation procedure, AT-108.

NG → Check control valve again. Repair or replace control valve assembly.

INSPECTION END

COMPONENT INSPECTION

Shift solenoid valve A

- For removal, refer to AT-204.

Resistance check

- Check resistance between two terminals.

Solenoid valve	Terminal No.		Resistance (Approx.)
Shift solenoid valve A	②	Ground	20 - 40Ω

GI
MA
EM
LC
EC
FE
CL
MT
AT
FA
RA
BR
ST
RS
BT
HA
EL
IDX

TROUBLE DIAGNOSIS FOR DTC P0733

A/T 3rd Gear Function (Cont'd)

Operation check

- Check solenoid valve by listening for its operating sound while applying battery voltage to the terminal and ground.

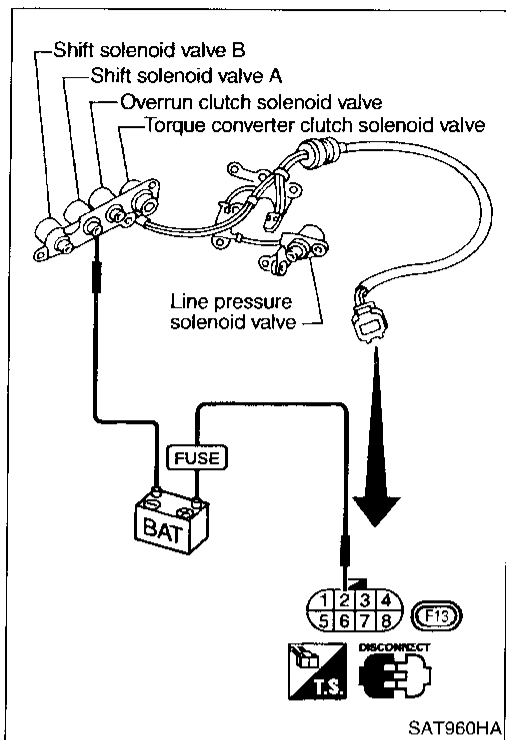

TROUBLE DIAGNOSIS FOR DTC P0734

A/T 4th Gear Function

DESCRIPTION

- This is an OBD-II self-diagnostic item and not available in TCM self-diagnosis.
- This malfunction will not be detected while the O/D OFF indicator lamp is indicating another self-diagnosis malfunction.
- This malfunction is detected when the A/T does not shift into fourth gear position or the torque converter clutch does not lock up as instructed by the TCM. This is not caused by electrical malfunction (circuits open or shorted) but by mechanical malfunction such as control valve sticking, improper solenoid valve operation, malfunctioning oil pump or torque converter clutch, etc.

Gear position	1	2	3	4
Shift solenoid valve A	ON (Closed)	OFF (Open)	OFF (Open)	ON (Closed)
Shift solenoid valve B	ON (Closed)	ON (Closed)	OFF (Open)	OFF (Open)



CONSULT REFERENCE VALUE IN DATA MONITOR MODE

Remarks: Specification data are reference values.

Monitor item	Condition	Specification
Torque converter clutch solenoid valve duty	Lock-up "OFF"	Approximately 4%
	↓ Lock-up "ON"	↓ Approximately 94%
Line pressure solenoid valve duty	Small throttle opening (Low line pressure)	Approximately 24%
	↓ Large throttle opening (High line pressure)	↓ Approximately 95%

TCM TERMINALS AND REFERENCE VALUE

Remarks: Specification data are reference values.

Terminal No.	Wire color	Item	Condition	Judgement standard
1	R/W	Line pressure solenoid valve	 When releasing accelerator pedal after warming up engine.	1.5 - 2.5V
			When depressing accelerator pedal fully after warming up engine.	0.5V or less
2	P/B	Line pressure solenoid valve (with dropping resistor)	 When releasing accelerator pedal after warming up engine.	5 - 14V
			When depressing accelerator pedal fully after warming up engine.	0.5V or less
5	R	Torque converter clutch solenoid valve	When A/T performs lock-up.	8 - 15V
			When A/T does not perform lock-up.	1V or less
6	L/W	Shift solenoid valve A	When shift solenoid valve A operates. (When driving in "D ₁ " or "D ₄ ".)	Battery voltage
			When shift solenoid valve A does not operate. (When driving in "D ₂ " or "D ₃ ".)	1V or less
7	L/Y	Shift solenoid valve B	When shift solenoid valve B operates. (When driving in "D ₁ " or "D ₂ ".)	Battery voltage
			When shift solenoid valve B does not operate. (When driving in "D ₃ " or "D ₄ ".)	1V or less
8	L/B	Overrun clutch solenoid valve	When overrun clutch solenoid valve operates.	Battery voltage
			When overrun clutch solenoid valve does not operate.	1V or less

TROUBLE DIAGNOSIS FOR DTC P0734

A/T 4th Gear Function (Cont'd)

ON BOARD DIAGNOSTIC LOGIC

This diagnosis monitors actual gear position by checking the torque converter slip ratio calculated by TCM as follows:

Torque converter slip ratio = A x C/B

A: Output shaft revolution signal from revolution sensor

B: Engine speed signal from ECM



C: Gear ratio determined as gear position which TCM supposes

If the actual gear position is much lower than the position (4th) supposed by TCM, the slip ratio will be much less than normal. In case the ratio does not reach the specified value, TCM judges this diagnosis malfunction.

This malfunction will be caused when shift solenoid valve B is stuck closed.

Gear position supposed by TCM	1	2	3	4
In case of gear position with no malfunctions	1	2	3	4
In case of gear position with shift solenoid valve B stuck closed	1	2	2	①

○: P0734 is detected.

Diagnostic trouble code	Malfunction is detected when ...	Check item (Possible cause)
 : A/T 4TH GR FNCTN  : P0734  : MIL Code No. 1106	A/T cannot be shifted to the 4th gear position even if electrical circuit is good.	<ul style="list-style-type: none"> ● Shift solenoid valve A ● Shift solenoid valve B ● Overrun clutch solenoid valve ● Line pressure solenoid valve ● Each clutch ● Hydraulic control circuit ● Torque converter clutch solenoid valve

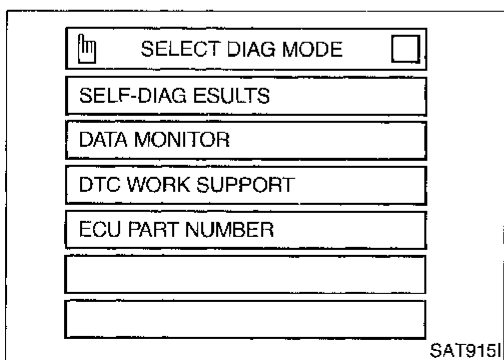
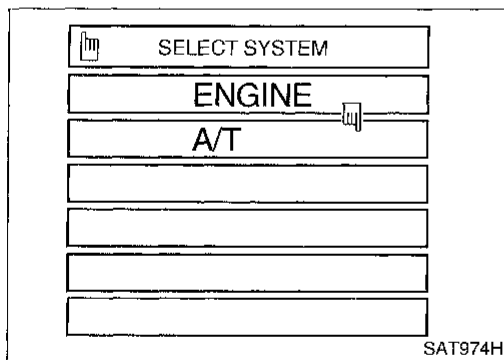

DIAGNOSTIC TROUBLE CODE (DTC) CONFIRMATION PROCEDURE

CAUTION:

- Always drive vehicle at a safe speed.
- If conducting this "DTC CONFIRMATION PROCEDURE" again, always turn ignition switch "OFF" and wait at least 5 seconds before continuing.
- Be careful not to rev engine into the red zone on the tachometer.

NOTE:

Always drive vehicle on a level road to improve the accuracy of test.

After the repair, perform the following procedure to confirm the malfunction is eliminated.

- 1) Start engine and select "DATA MONITOR" mode for "A/T" with CONSULT.
- 2) Make sure that output voltage of A/T fluid temperature sensor is within the range below.

FLUID TEMP SEN: 0.4 - 1.5V

If out of range, drive the vehicle to decrease the voltage (warm up the fluid) or stop engine to increase the voltage (cool down the fluid).

TROUBLE DIAGNOSIS FOR DTC P0734

A/T 4th Gear Function (Cont'd)

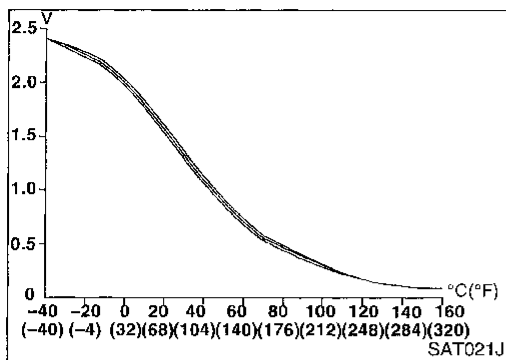

- 3) Select "4TH GR FNCTN P0734" of "DTC WORK SUPPORT" mode for "A/T" with CONSULT and touch "START".
- 4) Accelerate vehicle to 39 to 50 km/h (24 to 31 MPH) under the following condition and release the accelerator pedal completely.
THROTTLE POSI: Less than 5.5/8
Selector lever: D position (OD "ON")
 - Check that "GEAR" shows "3" after releasing pedal.
- 5) Depress accelerator pedal with 1/8 - 2/8 of "THROTTLE POSI" from a speed of 39 to 50 km/h (24 to 31 MPH) until "TESTING" has turned to "STOP VEHICLE" or "COMPLETE". (It will take approximately 3 seconds.)
 If the check result NG appears on CONSULT screen, go to "DIAGNOSTIC PROCEDURE", AT-118.
 If "STOP VEHICLE" appears on CONSULT screen, go to following step.
 - Check that "GEAR" shows "4" when depressing accelerator pedal with 1/8 - 2/8 of "THROTTLE POSI".
 - If "TESTING" does not appear on CONSULT for a long time, select "SELF-DIAG RESULTS" for "ENGINE". In case a 1st trip DTC other than P0734 is shown, refer to applicable "TROUBLE DIAGNOSIS FOR DTC".
- 6) Stop vehicle.
- 7) Follow the instruction displayed. (Check for normal shifting referring to the table below.)

Vehicle condition	Gear on actual transmission shift pattern when screen is changed to 1 → 2 → 3 → 4
No malfunction exists	1 → 2 → 3 → 4
Malfunction for P0734 exists.	1 → 2 → 2 → 1

- 8) Make sure that "OK" is displayed. (If "NG" is displayed, refer to "DIAGNOSTIC PROCEDURE".) Refer to "DIAGNOSTIC PROCEDURE", AT-118. Refer to shift schedule, AT-301.

OR



- 1) Start engine and warm up ATF.
- 2) Accelerate vehicle to 39 to 50 km/h (24 to 31 MPH) under the following condition and release the accelerator pedal completely.
THROTTLE POSI: Less than 5.5/8
Selector lever: D position (OD "ON")
 Refer to shift schedule, AT-301.
- 3) Depress accelerator pedal with 1/8 - 2/8 of "THROTTLE POSI" from a speed of 39 to 50 km/h (24 to 31 MPH). (It will take approximately 3 seconds.)
- 4) Select "MODE 7" with GST.

OR



- 1) Start engine and warm up ATF.
- 2) Accelerate vehicle to 39 to 50 km/h (24 to 31 MPH) under the following condition and release the accelerator pedal completely.

TROUBLE DIAGNOSIS FOR DTC P0734

A/T 4th Gear Function (Cont'd)

THROTTLE POSI: Less than 5.5/8

Selector lever: D position (OD "ON")

Refer to shift schedule, AT-301.

- 3) Depress accelerator pedal with 1/8 - 2/8 of "THROTTLE POSI" from a speed of 39 to 50 km/h (24 to 31 MPH). (It will take approximately 3 seconds.)
- 4) Perform self-diagnosis for ECM.
Refer to EC section ["Malfunction Indicator Lamp (MIL)", "ON BOARD DIAGNOSTIC SYSTEM DESCRIPTION"].

TROUBLE DIAGNOSIS FOR DTC P0734

A/T 4th Gear Function (Cont'd)

WIRING DIAGRAM — AT — 4TH

AT-4THSIG-01

: Detectable line for DTC
 : Non-detectable line for DTC

CI
 MA
 EM
 LC
 EC
 FE
 CL
 MT
AT
 FA
 RA
 BR
 ST
 RS
 BT
 HA
 EL
 DX

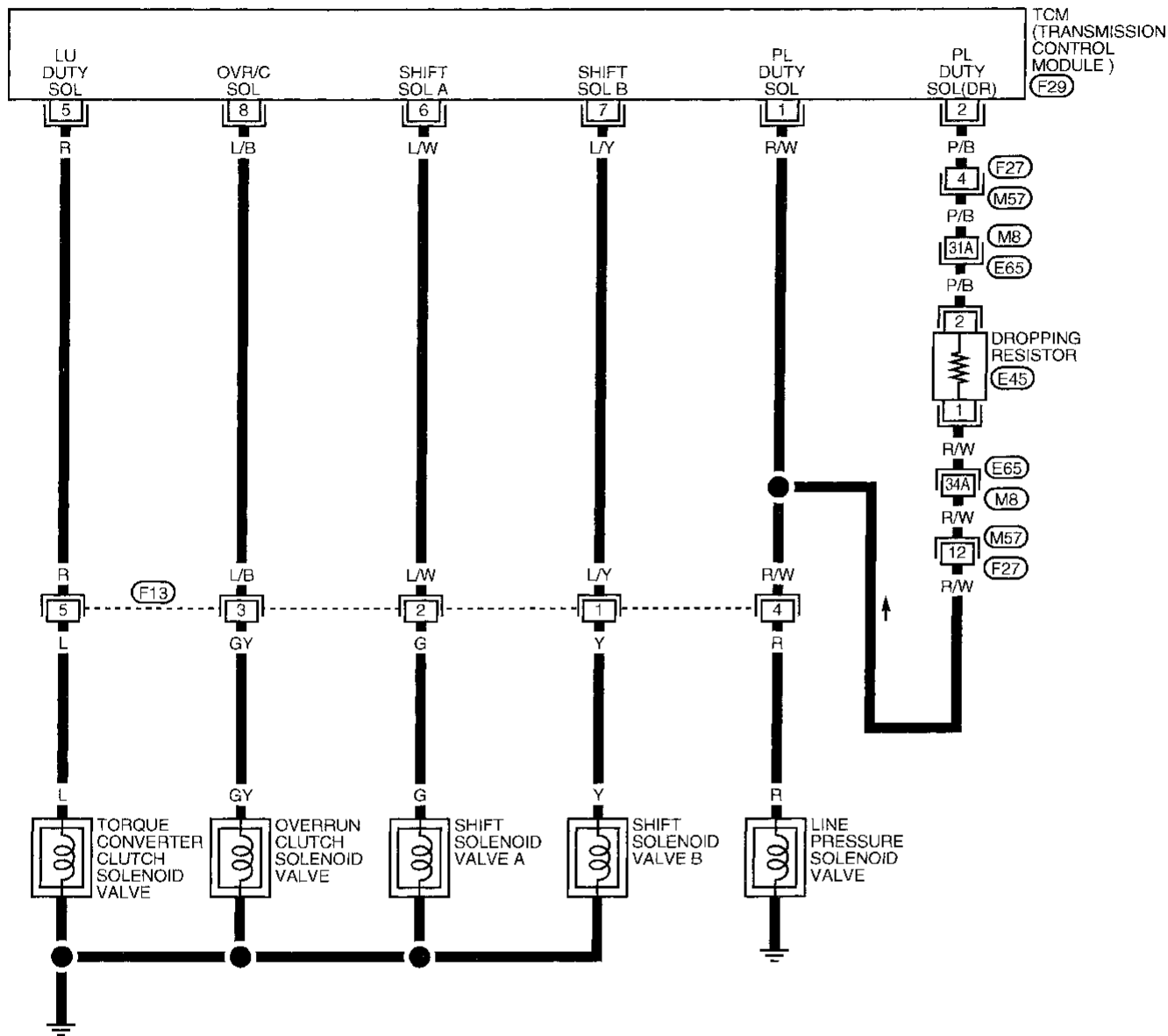

Refer to last page (Foldout page).

(M8) (E65)

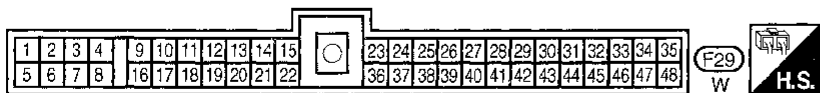
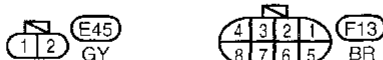
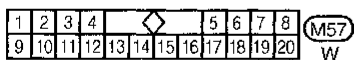

TROUBLE DIAGNOSIS FOR DTC P0734

A/T 4th Gear Function (Cont'd)

DIAGNOSTIC PROCEDURE

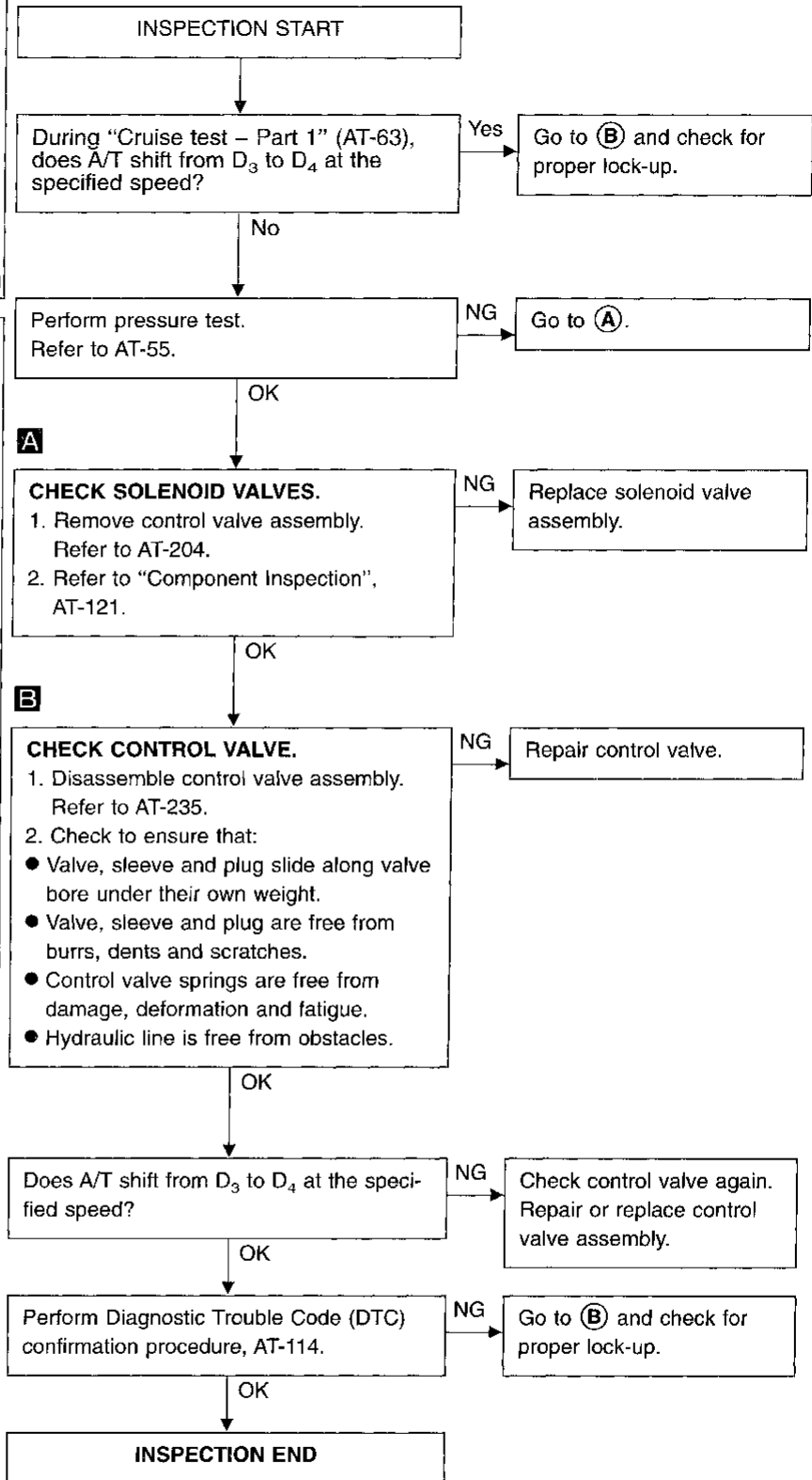
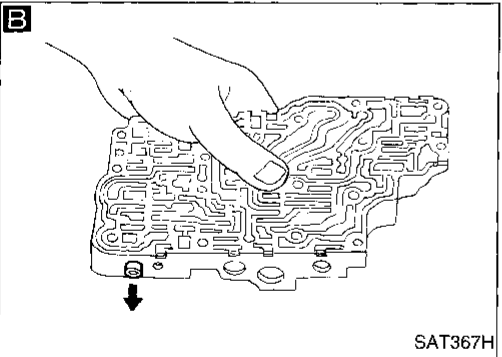
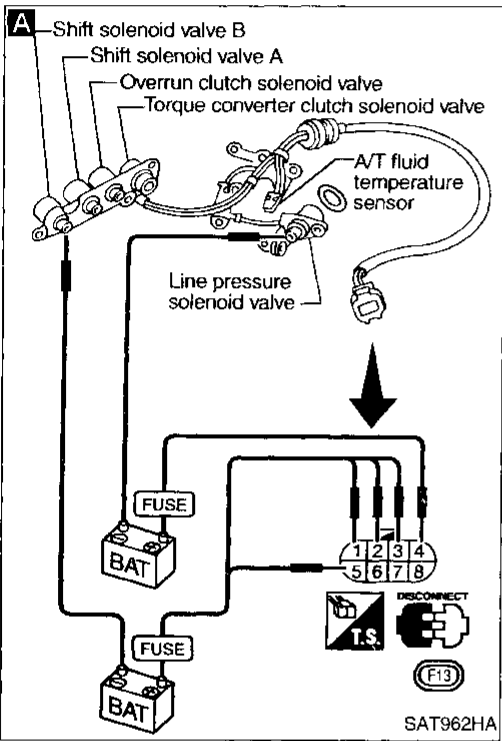
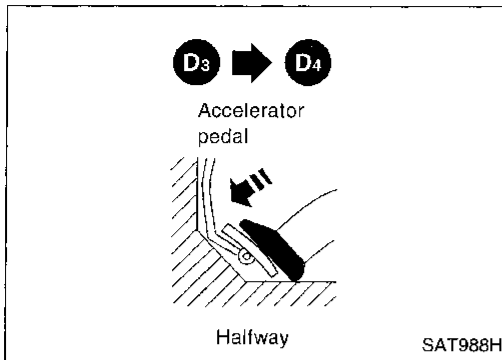

TROUBLE DIAGNOSIS FOR DTC P0734

A/T 4th Gear Function (Cont'd)

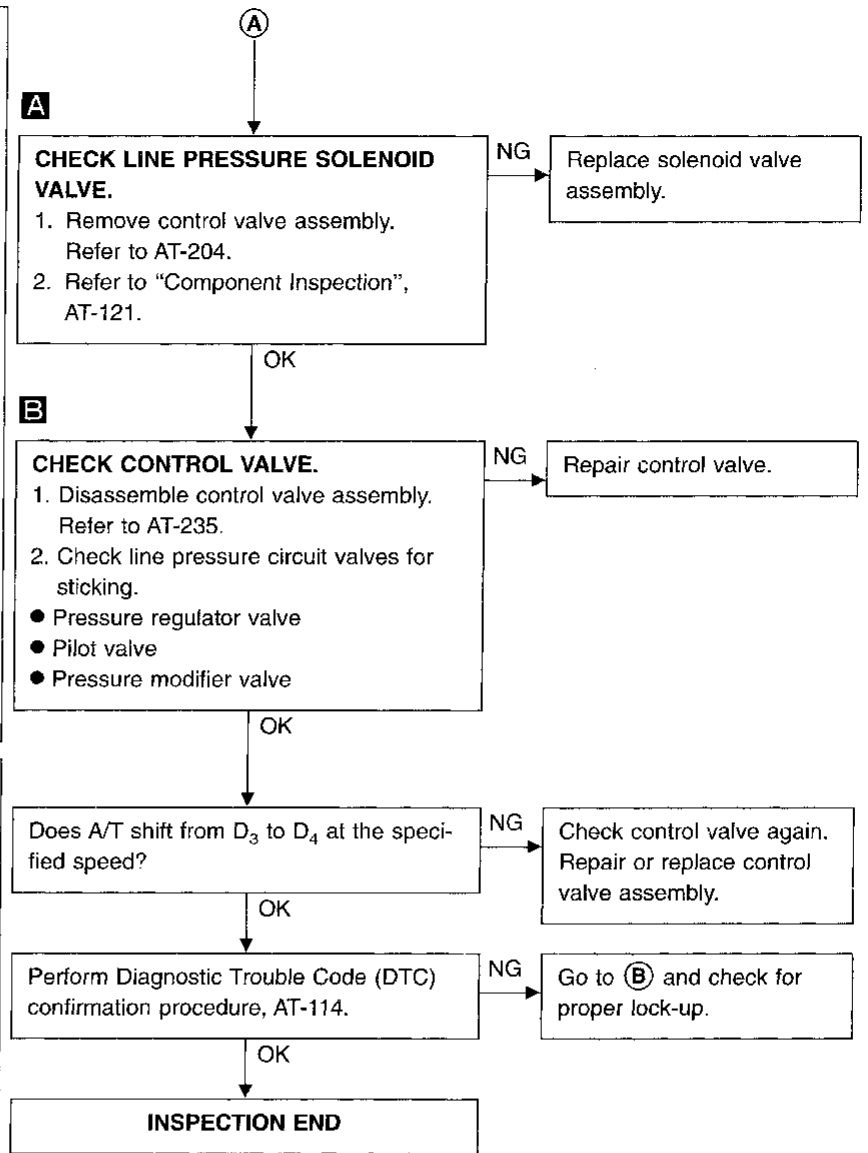
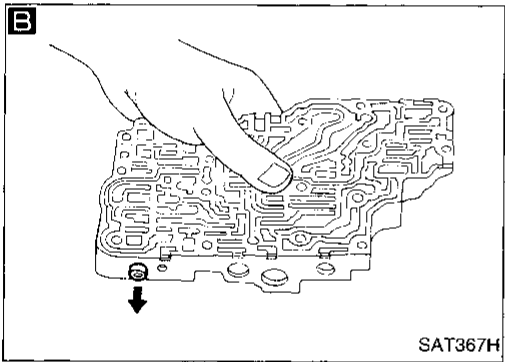
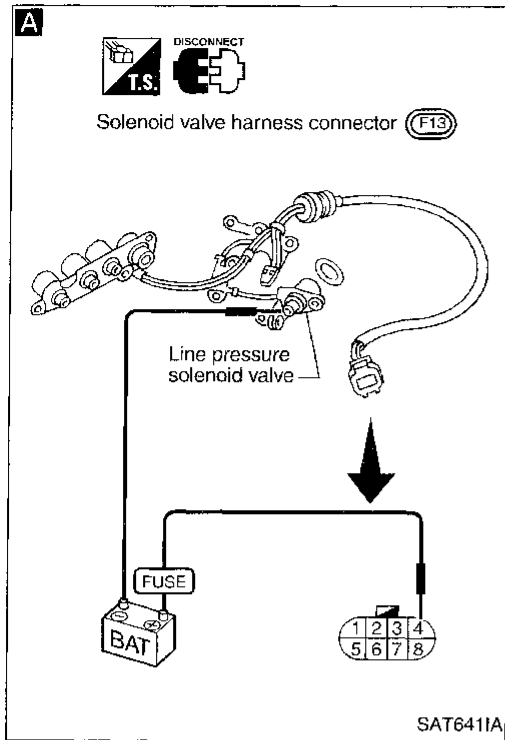

GI
MA
EM
LC
EC
FE
CL
MT
AT
FA
RA
BR
ST
RS
BT
HA
EL
IDX

TROUBLE DIAGNOSIS FOR DTC P0734

A/T 4th Gear Function (Cont'd)

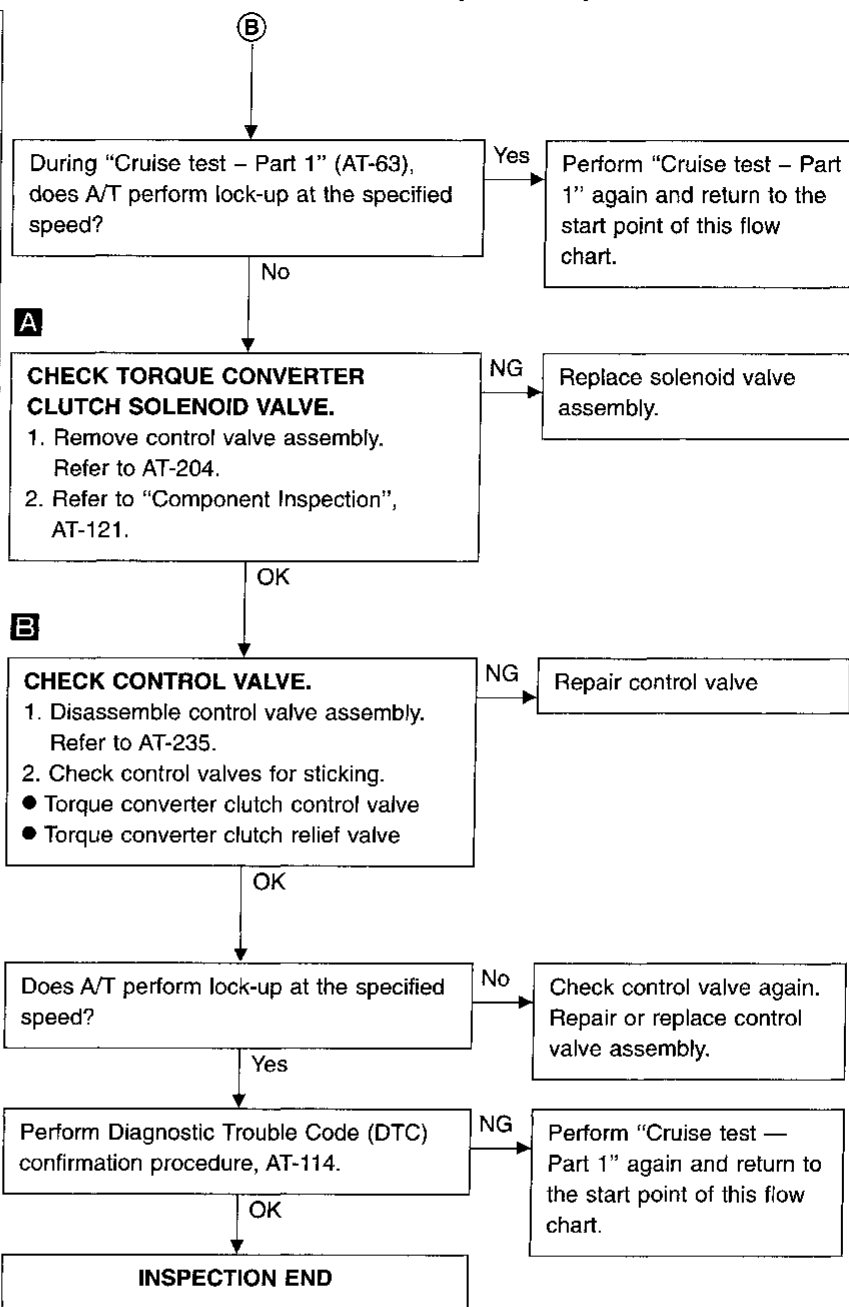
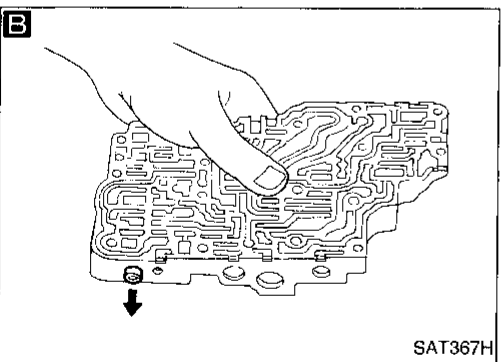
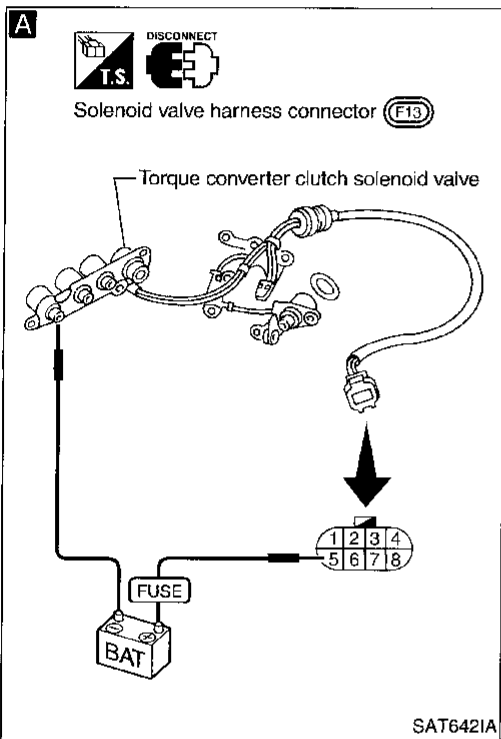
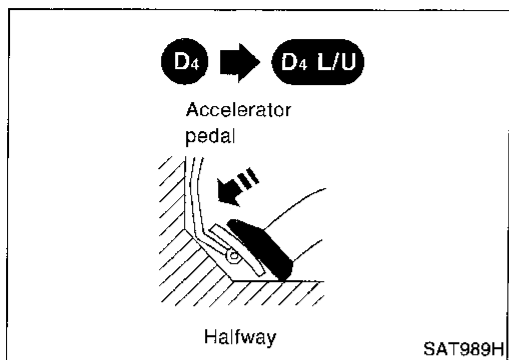

TROUBLE DIAGNOSIS FOR DTC P0734

A/T 4th Gear Function (Cont'd)

COMPONENT INSPECTION

Solenoid valves

- For removal, refer to AT-204.

Resistance check

- Check resistance between two terminals.

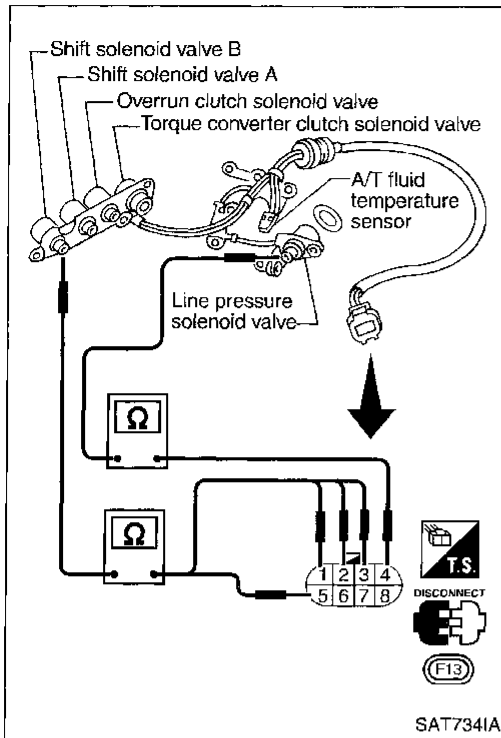

Solenoid valve	Terminal No.	Resistance (Approx.)
Shift solenoid valve A	②	20 - 40Ω
Shift solenoid valve B	①	
Overrun clutch solenoid valve	③	
Line pressure solenoid valve	④	2.5 - 5Ω
Torque converter clutch solenoid valve	⑤	10 - 16Ω

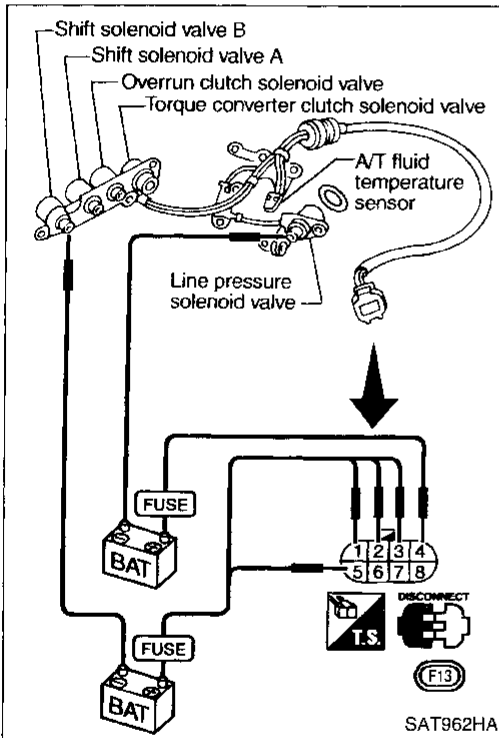

Operation check

- Check solenoid valve by listening for its operating sound while applying battery voltage to the terminal and ground.

TROUBLE DIAGNOSIS FOR DTC P0740

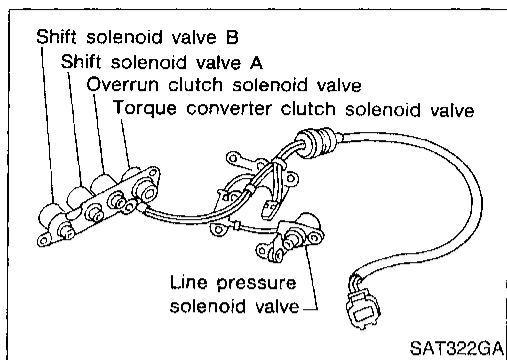

Torque Converter Clutch Solenoid Valve

DESCRIPTION

The torque converter clutch solenoid valve is activated, with the gear in "D₄", by the TCM in response to signals sent from the vehicle speed and throttle position sensors. Lock-up piston operation will then be controlled.

Lock-up operation, however, is prohibited when A/T fluid temperature is too low.

When the accelerator pedal is depressed (less than 2/8) in lock-up condition, the engine speed should not change abruptly. If there is a big jump in engine speed, there is no lock-up.

CONSULT REFERENCE VALUE IN DATA MONITOR MODE

Remarks: Specification data are reference values.

Monitor item	Condition	Specification
Torque converter clutch solenoid valve duty	Lock-up "OFF"	Approximately 4%
	Lock-up "ON"	Approximately 94%

TCM TERMINALS AND REFERENCE VALUE

Remarks: Specification data are reference values.

Terminal No.	Wire color	Item	Condition	Judgement standard	
5	R	Torque converter clutch solenoid valve		When A/T performs lock-up.	8 - 15V
				When A/T does not perform lock-up.	1V or less

ON BOARD DIAGNOSIS LOGIC

Diagnostic trouble code	Malfunction is detected when ...	Check item (Possible cause)
: TCC SOLENOID/CIRC : P0740 : MIL Code No. 1204	TCM detects an improper voltage drop when it tries to operate the solenoid valve.	<ul style="list-style-type: none"> ● Harness or connectors (The solenoid circuit is open or shorted.) ● T/C clutch solenoid valve

TROUBLE DIAGNOSIS FOR DTC P0740

Torque Converter Clutch Solenoid Valve (Cont'd)

DIAGNOSTIC TROUBLE CODE (DTC) CONFIRMATION PROCEDURE

CAUTION:

If conducting this "DTC CONFIRMATION PROCEDURE" again, always turn ignition switch "OFF" and wait at least 5 seconds before continuing.

After the repair, perform the following procedure to confirm the malfunction is eliminated.

- 1) Turn ignition switch "ON".
- 2) Select "DATA MONITOR" mode for "ENGINE" with CONSULT and wait at least 1 second.

- OR
- 1) Turn ignition switch "ON".
 - 2) Select "MODE 7" with GST.

- OR
- 1) Turn ignition switch "ON".
 - 2) Perform self-diagnosis for ECM.
Refer to EC section ["Malfunction Indicator Lamp (MIL)", "ON BOARD DIAGNOSTIC SYSTEM DESCRIPTION"].

GI
MA
EM
LC
EC
FE
CL
MT
AT
FA
RA
BR
ST
RS
BT
HA
EL
IDX

TROUBLE DIAGNOSIS FOR DTC P0740

Torque Converter Clutch Solenoid Valve (Cont'd)

WIRING DIAGRAM — AT — TCV

AT-TCV-01

: Detectable line for DTC
 : Non-detectable line for DTC

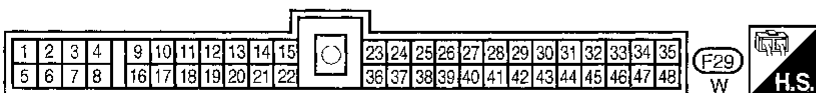
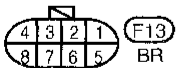
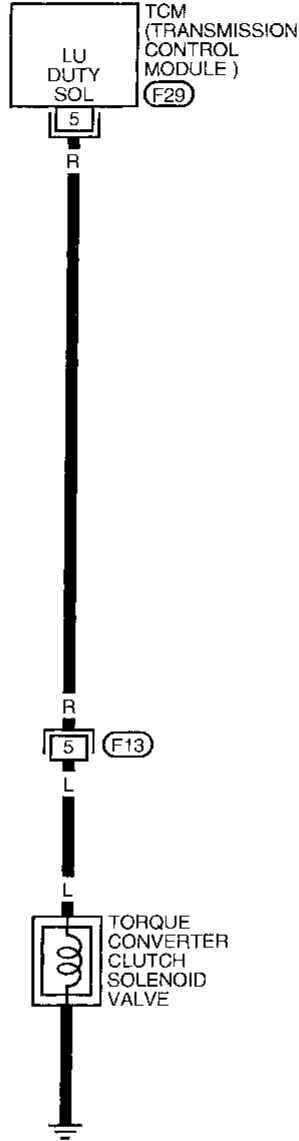

TROUBLE DIAGNOSIS FOR DTC P0740

Torque Converter Clutch Solenoid Valve (Cont'd)

DIAGNOSTIC PROCEDURE

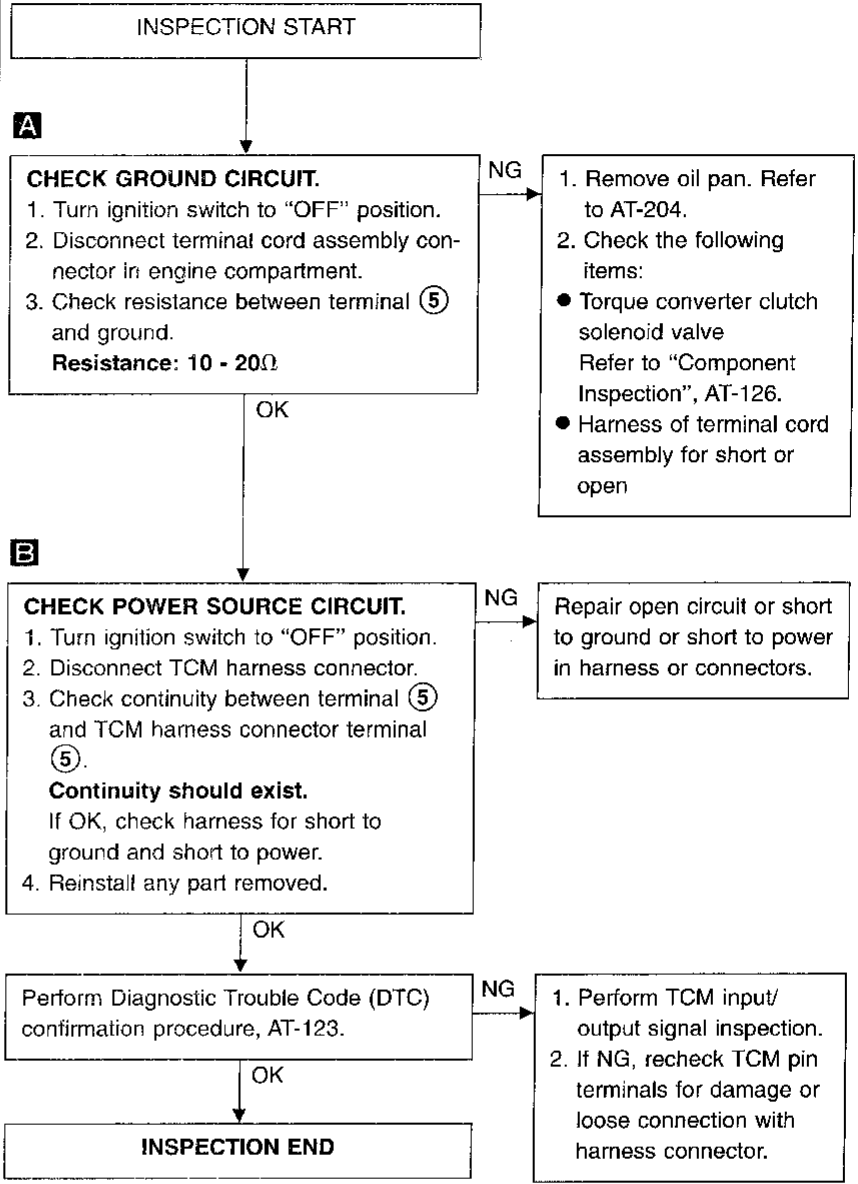
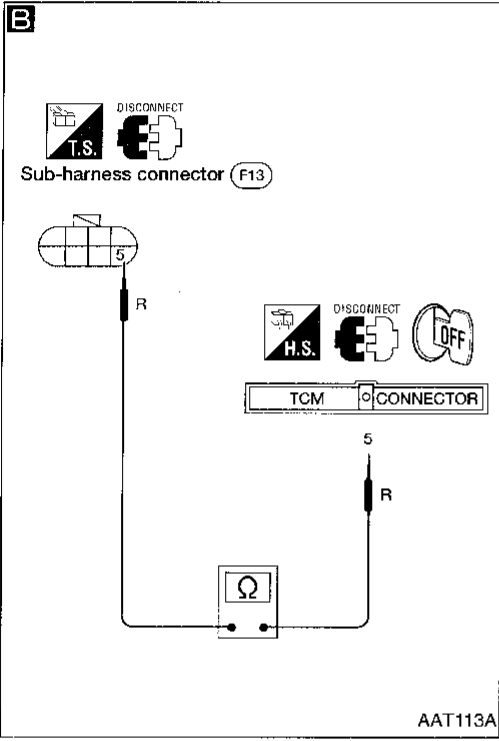
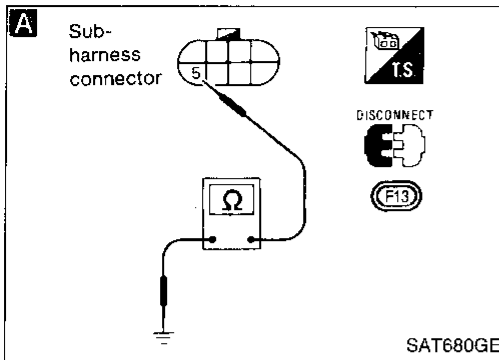

GI
MA
EM
LC
EC
FE
CL
MT
AT
FA
RA
BR
ST
RS
BT
HA
EL
IDX

TROUBLE DIAGNOSIS FOR DTC P0740

Torque Converter Clutch Solenoid Valve (Cont'd)

COMPONENT INSPECTION

Torque converter clutch solenoid valve

- For removal, refer to AT-204.

Resistance check

- Check resistance between two terminals.

Solenoid valve	Terminal No.		Resistance (Approx.)
Torque converter clutch solenoid valve	⑤	Ground	10 - 16Ω

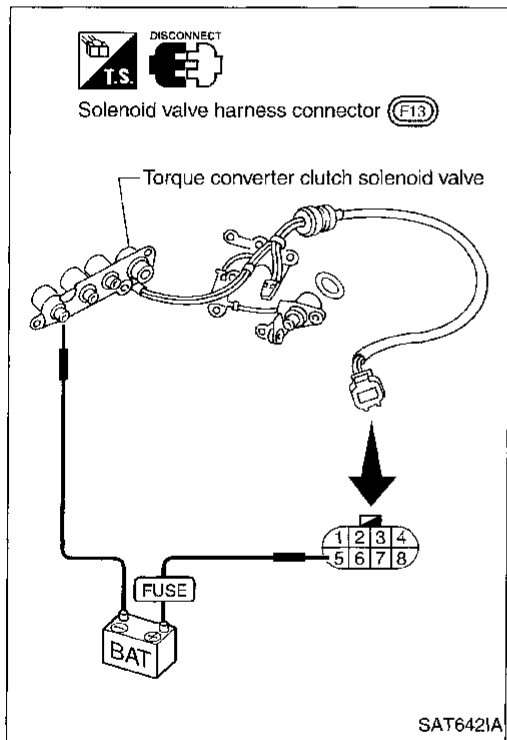
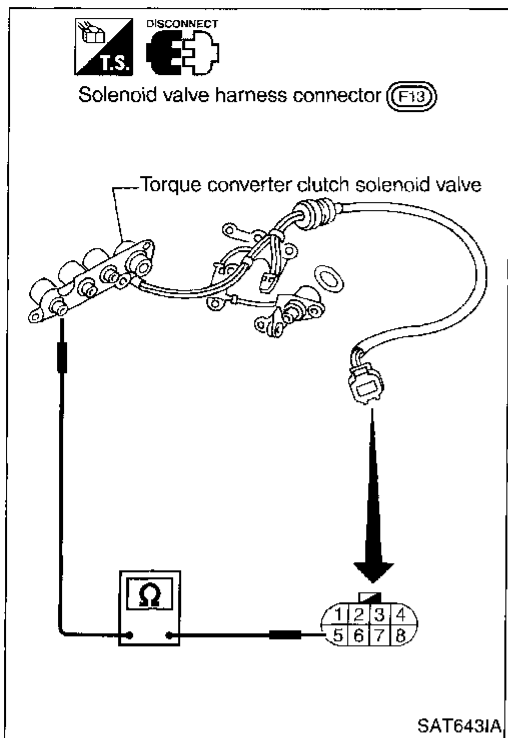

Operation check

- Check solenoid valve by listening for its operating sound while applying battery voltage to the terminal and ground.

TROUBLE DIAGNOSIS FOR DTC P0744

A/T TCC S/V Function (Lock-up)

DESCRIPTION

- This is an OBD-II self-diagnostic item and not available in TCM self-diagnosis.
- This malfunction will not be detected while the O/D OFF indicator lamp is indicating another self-diagnosis malfunction.
- This malfunction is detected when the A/T does not shift into fourth gear position or the torque converter clutch does not lock up as instructed by the TCM. This is not caused by electrical malfunction (circuits open or shorted) but by mechanical malfunction such as control valve sticking, improper solenoid valve operation, malfunctioning oil pump or torque converter clutch, etc.







CONSULT REFERENCE VALUE IN DATA MONITOR MODE

Remarks: Specification data are reference values.

Monitor item	Condition	Specification
Torque converter clutch solenoid valve duty	Lock-up "OFF"	Approximately 4%
	↓ Lock-up "ON"	↓ Approximately 94%

TCM TERMINALS AND REFERENCE VALUE

Remarks: Specification data are reference values.

Terminal No.	Wire color	Item	Condition	Judgement standard	
1	R/W	Line pressure solenoid valve		When releasing accelerator pedal after warming up engine.	1.5 - 2.5V
				When depressing accelerator pedal fully after warming up engine.	0.5V or less
2	P/B	Line pressure solenoid valve (with dropping resistor)		When releasing accelerator pedal after warming up engine.	5 - 14V
				When depressing accelerator pedal fully after warming up engine.	0.5V or less
5	R	Torque converter clutch solenoid valve		When A/T performs lock-up.	8 - 15V
				When A/T does not perform lock-up.	1V or less
6	L/W	Shift solenoid valve A		When shift solenoid valve A operates. (When driving in "D ₁ " or "D ₄ ".)	Battery voltage
				When shift solenoid valve A does not operate. (When driving in "D ₂ " or "D ₃ ".)	1V or less
7	L/Y	Shift solenoid valve B		When shift solenoid valve B operates. (When driving in "D ₁ " or "D ₂ ".)	Battery voltage
				When shift solenoid valve B does not operate. (When driving in "D ₃ " or "D ₄ ".)	1V or less
8	L/B	Overrun clutch solenoid valve		When overrun clutch solenoid valve operates.	Battery voltage
				When overrun clutch solenoid valve does not operate.	1V or less

TROUBLE DIAGNOSIS FOR DTC P0744

A/T TCC S/V Function (Lock-up) (Cont'd)

ON BOARD DIAGNOSTIC LOGIC

This diagnosis monitors actual gear position by checking the torque converter slip ratio calculated by TCM as follows:

Torque converter slip ratio = $A \times C/B$

A: Output shaft revolution signal from revolution sensor

B: Engine speed signal from ECM



C: Gear ratio determined as gear position which TCM supposes

If the actual gear position is much lower than the position (4th) supposed by TCM, the slip ratio will be much less than normal. In case the ratio does not reach the specified value, TCM judges this diagnosis malfunction.

This malfunction will be caused when shift solenoid valve B is stuck closed.

Gear position supposed by TCM	1	2	3	4
In case of gear position with no malfunctions	1	2	3	4
In case of gear position with shift solenoid valve B stuck closed	1	2	2	①

①: P0744 is detected.

Diagnostic trouble code	Malfunction is detected when ...	Check item (Possible cause)
 : A/T TCC S/V FNCTN  : P0744  : MIL Code No. 1107	A/T cannot perform lock-up even if electrical circuit is good.	<ul style="list-style-type: none"> ● Torque converter clutch solenoid valve ● Each clutch ● Hydraulic control circuit

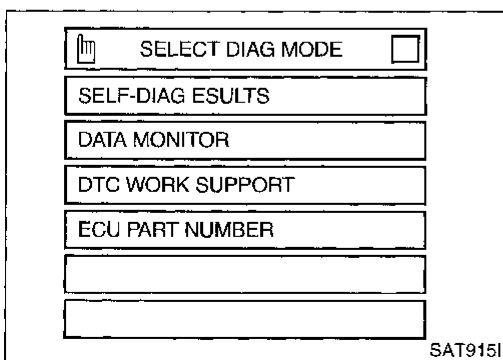
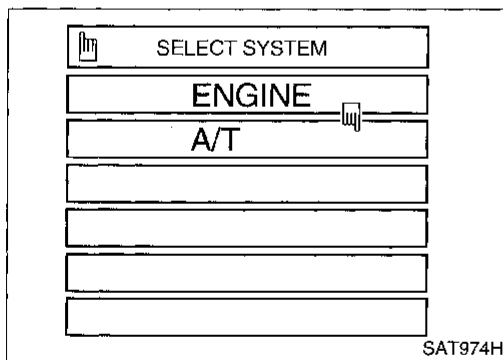

DIAGNOSTIC TROUBLE CODE (DTC) CONFIRMATION PROCEDURE

CAUTION:

- Always drive vehicle at a safe speed.
- If conducting this "DTC CONFIRMATION PROCEDURE" again, always turn ignition switch "OFF" and wait at least 5 seconds before continuing.

NOTE:

Always drive vehicle on a level road to improve the accuracy of test.

After the repair, perform the following procedure to confirm the malfunction is eliminated.

- 1) Start engine and select "DATA MONITOR" mode for "A/T" with CONSULT.
- 2) Make sure that output voltage of A/T fluid temperature sensor is within the range below.
FLUID TEMP SEN: 0.4 - 1.5V
 If out of range, drive the vehicle to decrease the voltage (warm up the fluid) or stop engine to increase the voltage (cool down the fluid).
- 3) Select "TCC S/V FNCTN P0744" of "DTC WORK SUPPORT" mode for "A/T" with CONSULT.

TROUBLE DIAGNOSIS FOR DTC P0744

A/T TCC S/V Function (Lock-up) (Cont'd)

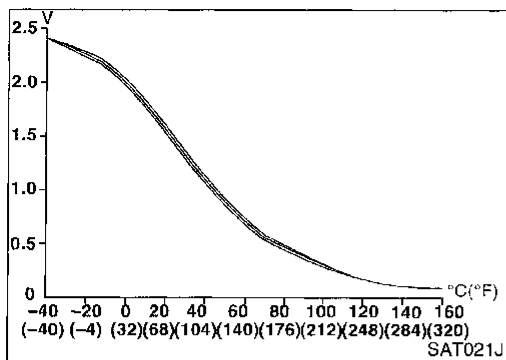

- 4) Accelerate vehicle to more than 70 km/h (43 MPH) and maintain the following condition continuously until "TESTING" has turned to "COMPLETE". (It will take approximately 30 seconds after "TESTING" shows.)

THROTTLE POSI: 1/8 - 2/8

Selector lever: D position (OD "ON")

TCC S/V DUTY: More than 94%

VHCL/S SE-A/T: Constant speed of more than 70 km/h (43 MPH)

- Check that "GEAR" shows "4".
 - For shift schedule, refer to SDS, AT-301.
 - If "TESTING" does not appear on CONSULT for a long time, select "SELF-DIAG RESULTS". In case a 1st trip DTC other than P0744 is shown, refer to applicable "TROUBLE DIAGNOSIS FOR DTC".
- 5) Make sure that "OK" is displayed. (If "NG" is displayed, refer to "DIAGNOSTIC PROCEDURE".) Refer to "DIAGNOSTIC PROCEDURE", AT-131. Refer to shift schedule, AT-301.

OR



- 1) Start engine and warm up ATF.
- 2) Start vehicle with selector lever in "D" (OD "ON"), throttle opening halfway and D₄ lock-up position for approximately 30 seconds. Check that vehicle runs through gear shift of D₁ → D₂ → D₃ → D₄ → D₄ lock-up, in accordance with shift schedule. Refer to shift schedule, AT-301.
- 3) Select "MODE 7" with GST.

OR



- 1) Start engine and warm up ATF.
- 2) Start vehicle with selector lever in "D" (OD "ON"), throttle opening halfway and D₄ lock-up position for approximately 30 seconds. Check that vehicle runs through gear shift of D₁ → D₂ → D₃ → D₄ → D₄ lock-up, in accordance with shift schedule. Refer to shift schedule, AT-301.
- 3) Perform self-diagnosis for ECM. Refer to EC section ["Malfunction Indicator Lamp (MIL)", "ON BOARD DIAGNOSTIC SYSTEM DESCRIPTION"].

TROUBLE DIAGNOSIS FOR DTC P0744

A/T TCC S/V Function (Lock-up) (Cont'd) WIRING DIAGRAM — AT — TCCSIG

AT-TCCSIG-01

— : Detectable line for DTC
— : Non-detectable line for DTC

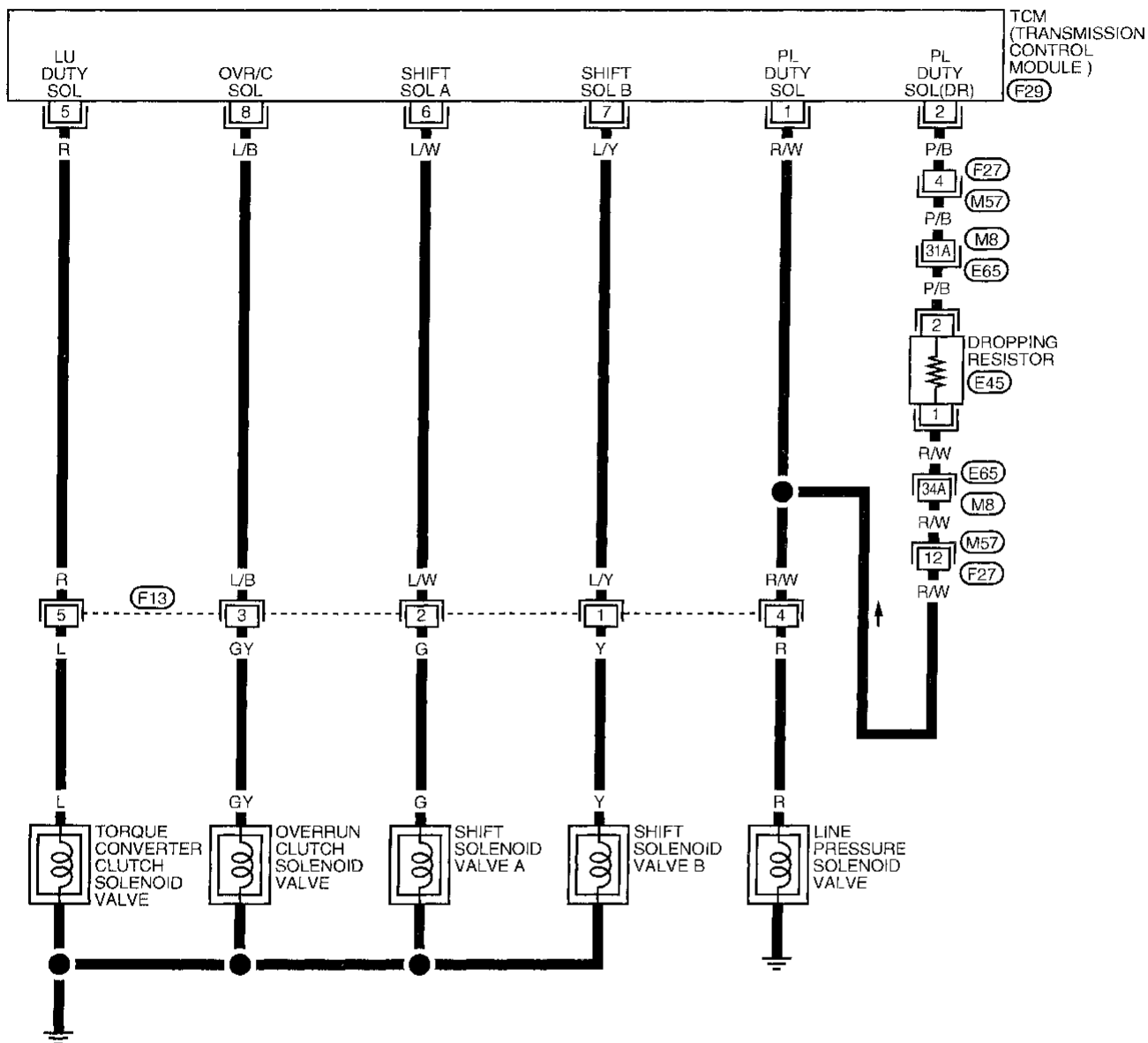

Refer to last page (Foldout page).

(M8), (E65)

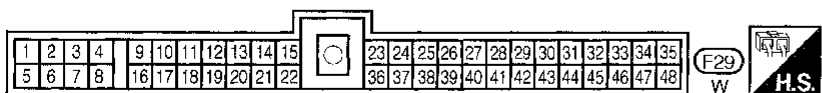
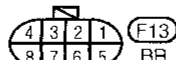
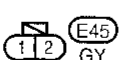

TROUBLE DIAGNOSIS FOR DTC P0744

A/T TCC S/V Function (Lock-up) (Cont'd) DIAGNOSTIC PROCEDURE

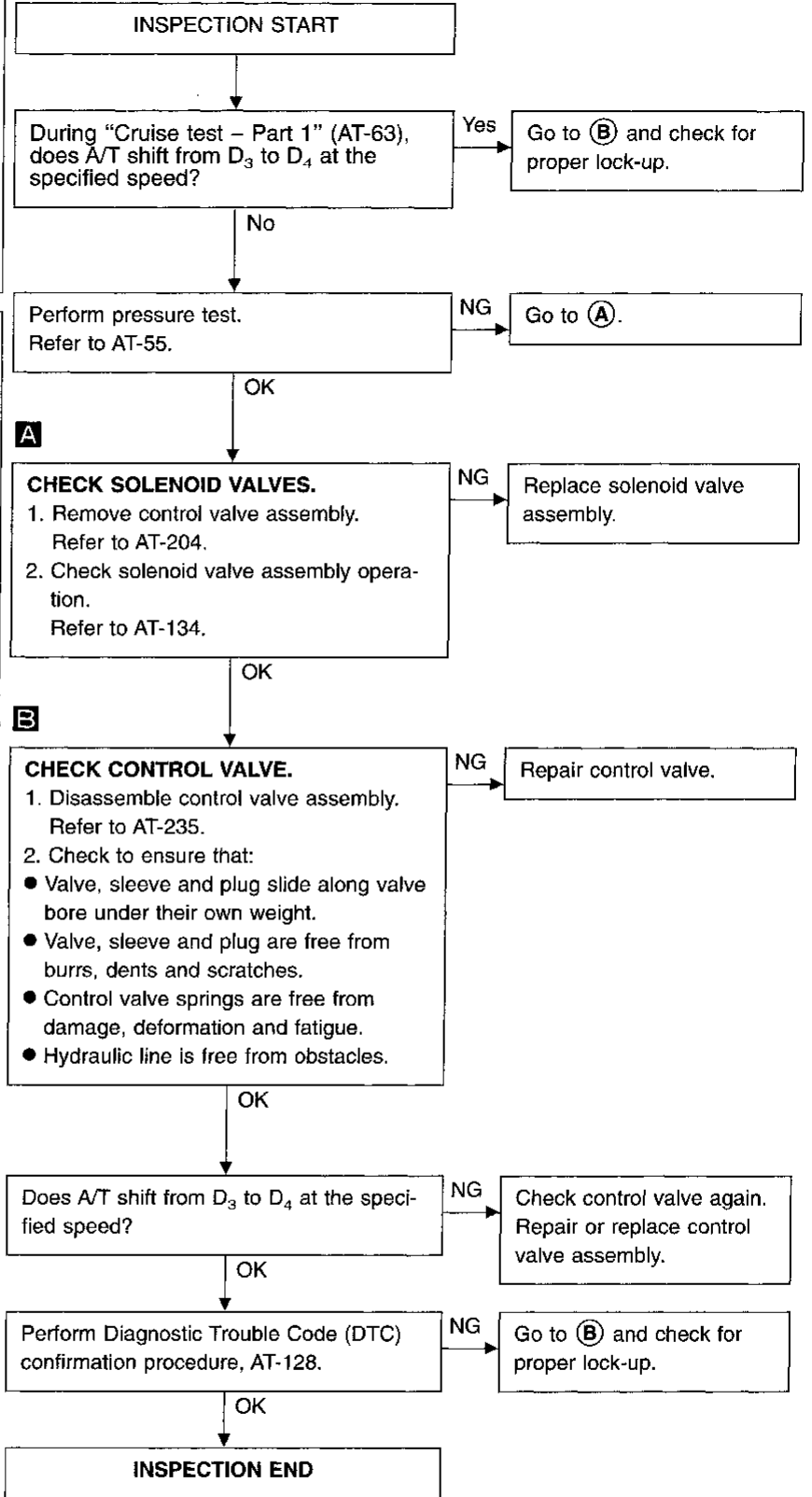
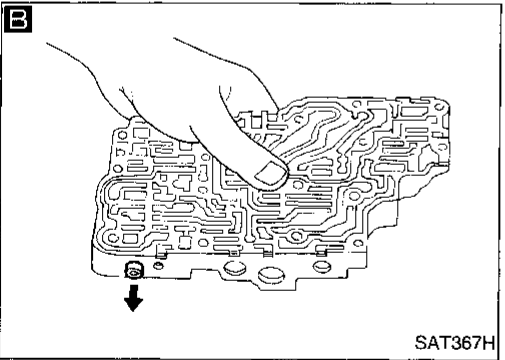
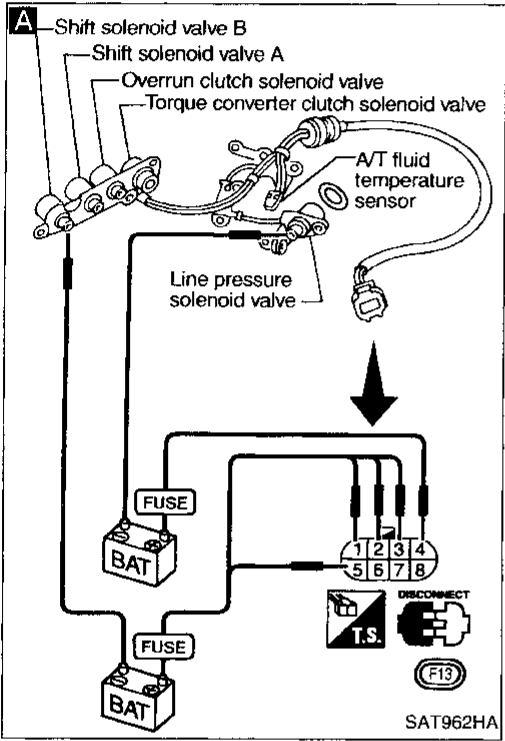
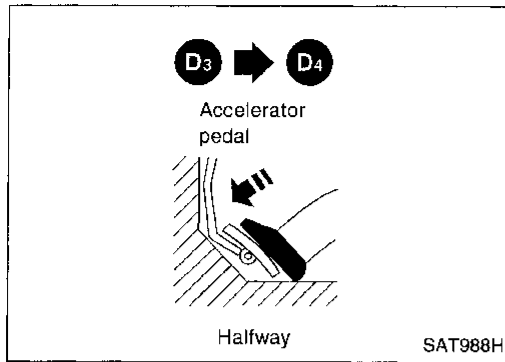

GI

MA

EM

LC

EC

FE

CL

MT

AT

FA

RA

BR

ST

RS

BT

HA

EL

IDX

TROUBLE DIAGNOSIS FOR DTC P0744

A/T TCC S/V Function (Lock-up) (Cont'd)

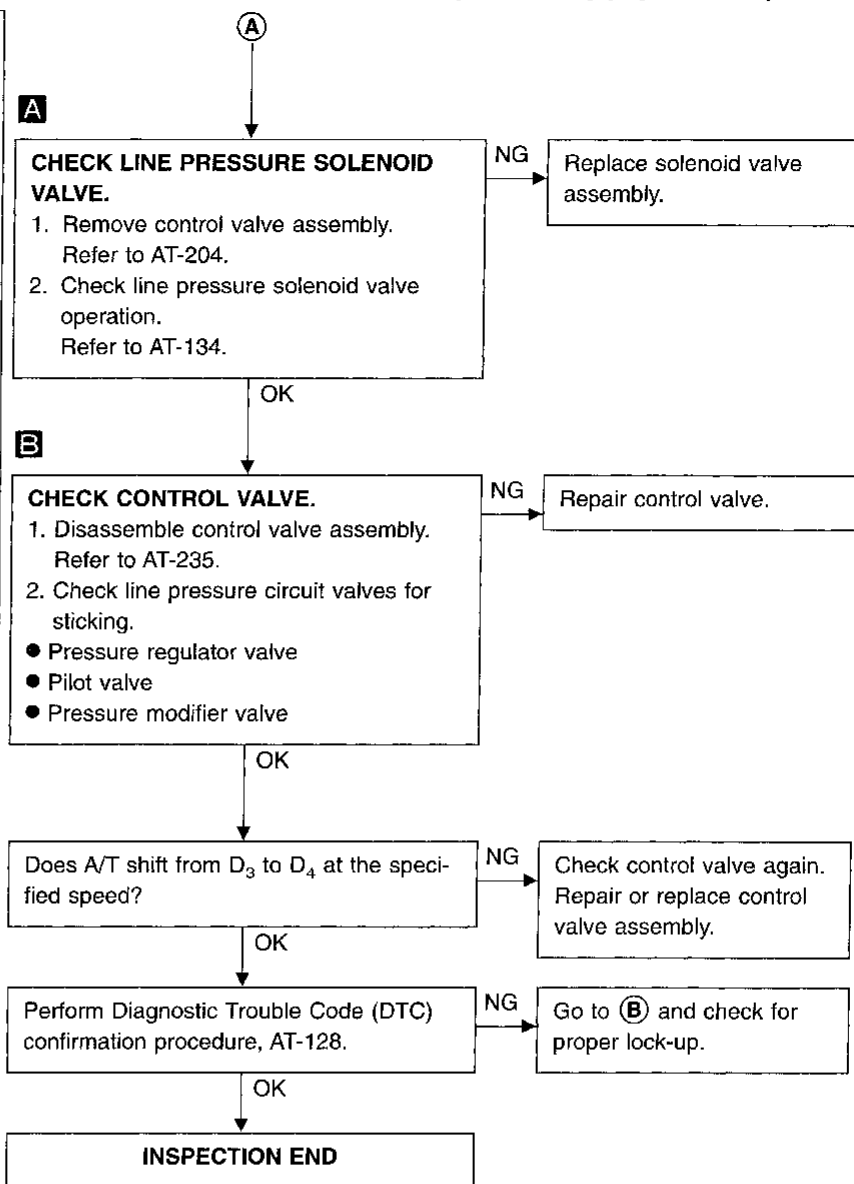
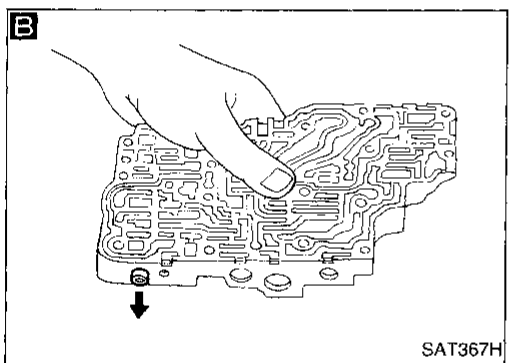
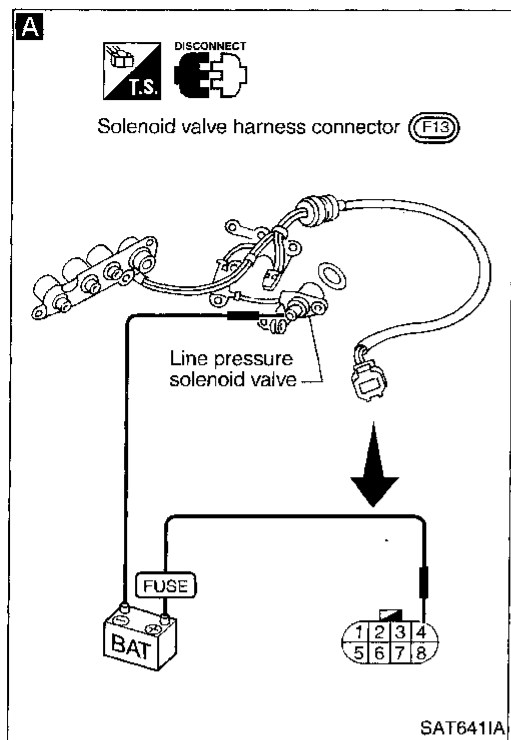

TROUBLE DIAGNOSIS FOR DTC P0744

A/T TCC S/V Function (Lock-up) (Cont'd)

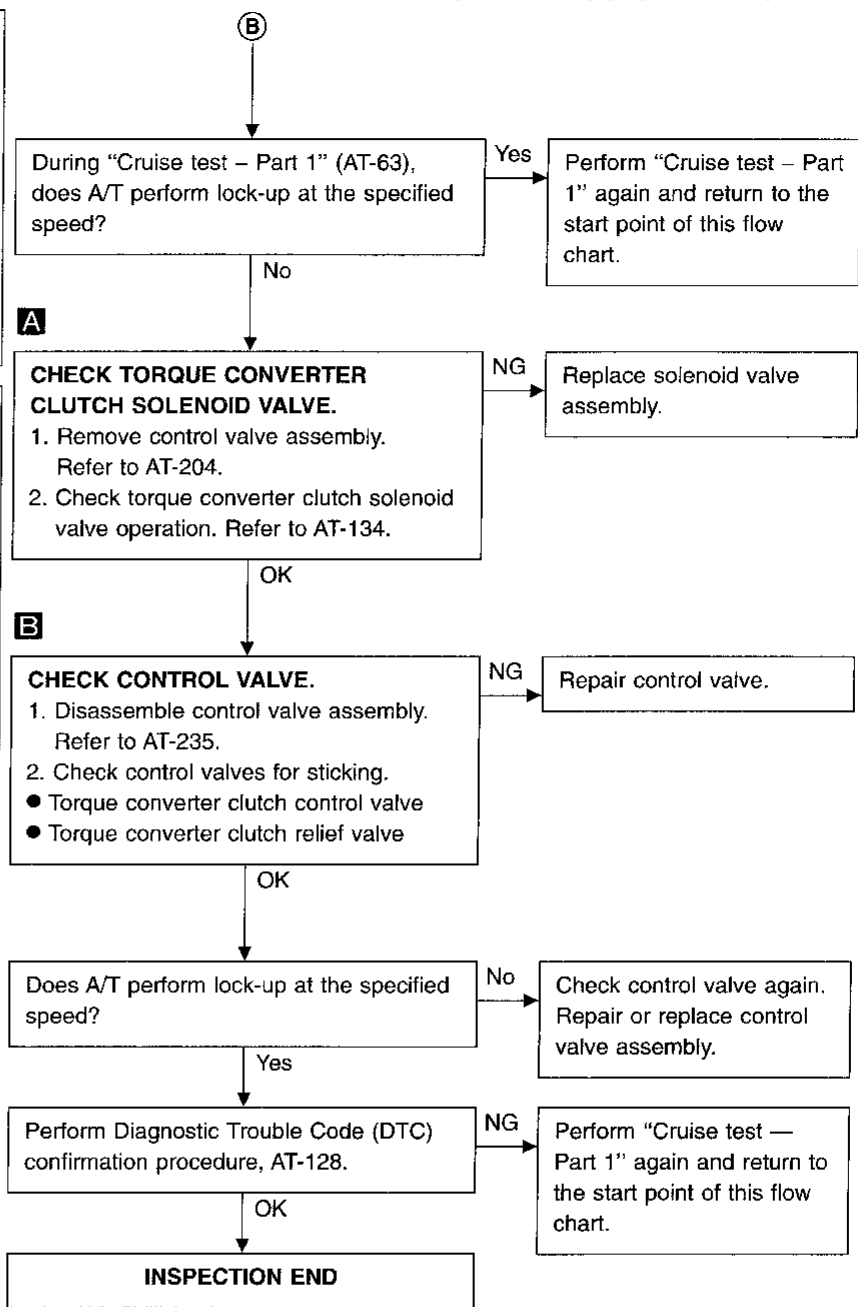
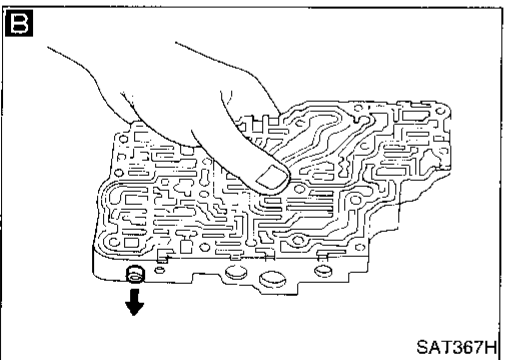
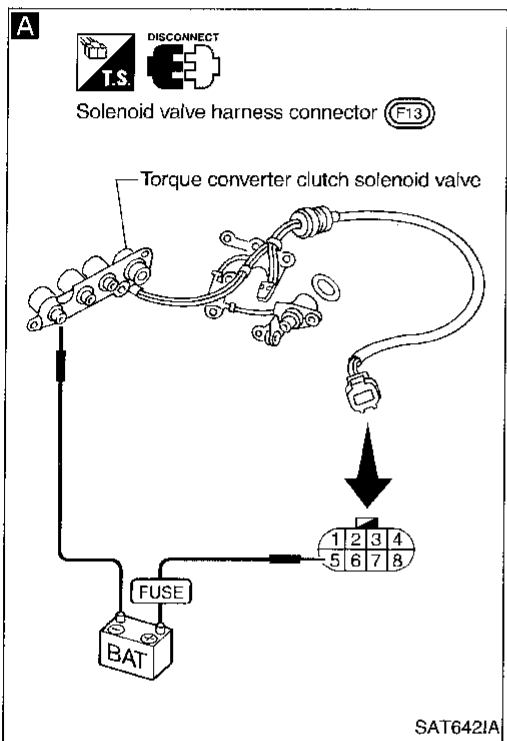
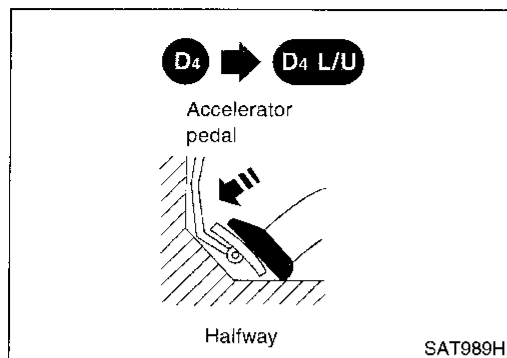

GI
MA
EM
LC
EC
FE
CL
MT
AT
FA
RA
BR
ST
RS
BT
HA
EL
IDX

TROUBLE DIAGNOSIS FOR DTC P0744

A/T TCC S/V Function (Lock-up) (Cont'd)

COMPONENT INSPECTION

Solenoid valves

- For removal, refer to AT-204.

Resistance check

- Check resistance between two terminals.

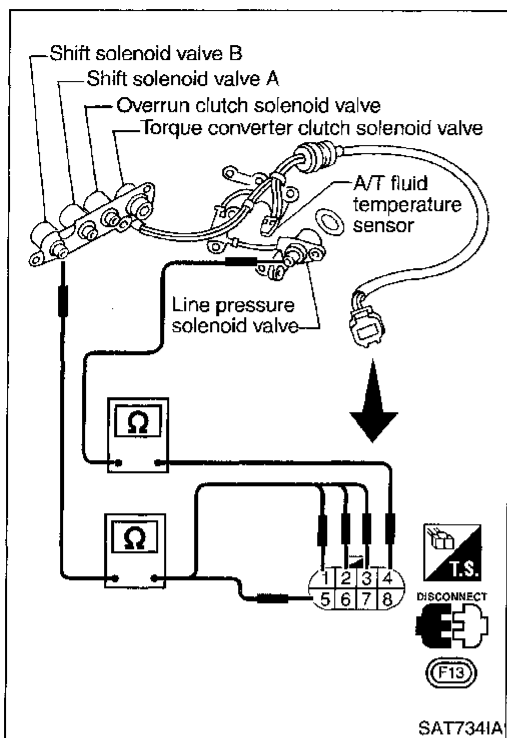

Solenoid valve	Terminal No.	Resistance (Approx.)
Shift solenoid valve A	②	20 - 40Ω
Shift solenoid valve B	①	
Overrun clutch solenoid valve	③	2.5 - 5Ω
Line pressure solenoid valve	④	
Torque converter clutch solenoid valve	⑤	10 - 16Ω

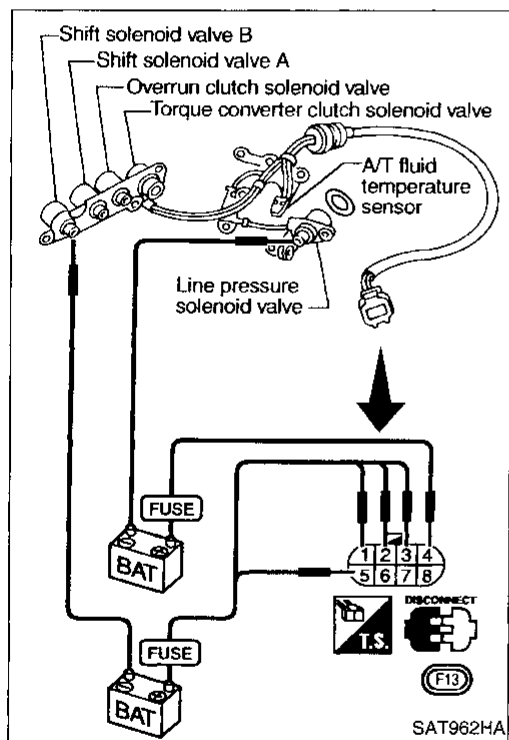

Operation check

- Check solenoid valve by listening for its operating sound while applying battery voltage to the terminal and ground.

TROUBLE DIAGNOSIS FOR DTC P0745

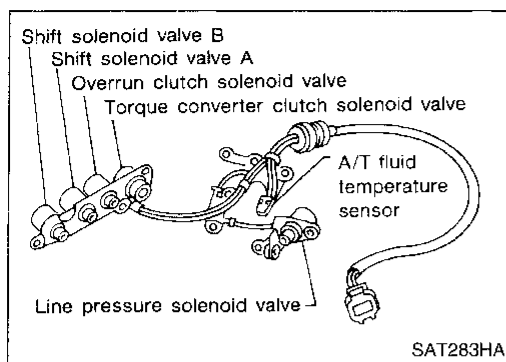

Line Pressure Solenoid Valve

DESCRIPTION

The line pressure solenoid valve regulates the oil pump discharge pressure to suit the driving condition in response to a signal sent from the TCM.

The line pressure duty cycle value is not consistent when the closed throttle position switch is "ON". To confirm the line pressure duty cycle at low pressure, the accelerator (throttle) should be open until the closed throttle position switch is "OFF".

CONSULT REFERENCE VALUE IN DATA MONITOR MODE



Remarks: Specification data are reference values.

Monitor item	Condition	Specification
Line pressure solenoid valve duty	Small throttle opening (Low line pressure)	Approximately 24%
	Large throttle opening (High line pressure)	Approximately 95%



Note: The line pressure duty cycle value is not consistent when the closed throttle position switch is "ON". To confirm the line pressure duty cycle at low pressure, the accelerator (throttle) should be open until the closed throttle position switch is "OFF".

TCM TERMINALS AND REFERENCE VALUE

Remarks: Specification data are reference values.

Terminal No.	Wire color	Item	Condition	Judgement standard
1	R/W	Line pressure solenoid valve	 When releasing accelerator pedal after warming up engine.	1.5 - 2.5V
			When depressing accelerator pedal fully after warming up engine.	0.5V or less
2	P/B	Line pressure solenoid valve (with dropping resistor)	 When releasing accelerator pedal after warming up engine.	5 - 14V
			When depressing accelerator pedal fully after warming up engine.	0.5V or less

ON BOARD DIAGNOSIS LOGIC

Diagnostic trouble code	Malfunction is detected when ...	Check item (Possible cause)
 : L/PRESS SOL/CIRC  : P0745  : MIL Code No. 1205	TCM detects an improper voltage drop when it tries to operate the solenoid valve.	<ul style="list-style-type: none"> ● Harness or connectors (The solenoid circuit is open or shorted.) ● Line pressure solenoid valve

TROUBLE DIAGNOSIS FOR DTC P0745

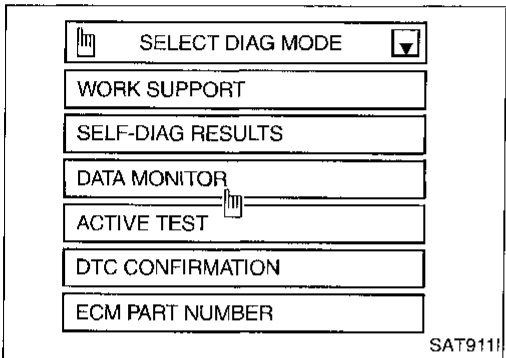
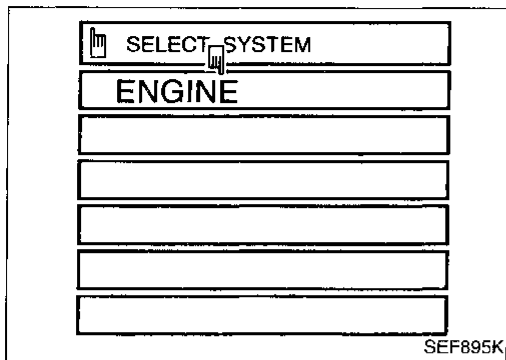

Line Pressure Solenoid Valve (Cont'd)

DIAGNOSTIC TROUBLE CODE (DTC) CONFIRMATION PROCEDURE

CAUTION:

If conducting this "DTC CONFIRMATION PROCEDURE" again, always turn ignition switch "OFF" and wait at least 5 seconds before continuing.

After the repair, perform the following procedure to confirm the malfunction is eliminated.

-  1) Turn ignition switch "ON" and select "DATA MONITOR" mode for "ENGINE" with CONSULT.
2) Depress accelerator pedal completely and wait at least 1 second.

OR

-  1) Turn ignition switch "ON".
2) Depress accelerator pedal completely and wait at least 1 second.
3) Select "MODE 7" with GST.

OR

-  1) Turn ignition switch "ON".
2) Depress accelerator pedal completely and wait at least 1 second.
3) Perform self-diagnosis for ECM.

Refer to EC section ["Malfunction Indicator Lamp (MIL)", "ON BOARD DIAGNOSTIC SYSTEM DESCRIPTION"].

TROUBLE DIAGNOSIS FOR DTC P0745

Line Pressure Solenoid Valve (Cont'd) WIRING DIAGRAM — AT — LPSV

AT-LPSV-01

— : Detectable line for DTC
 — : Non-detectable line for DTC

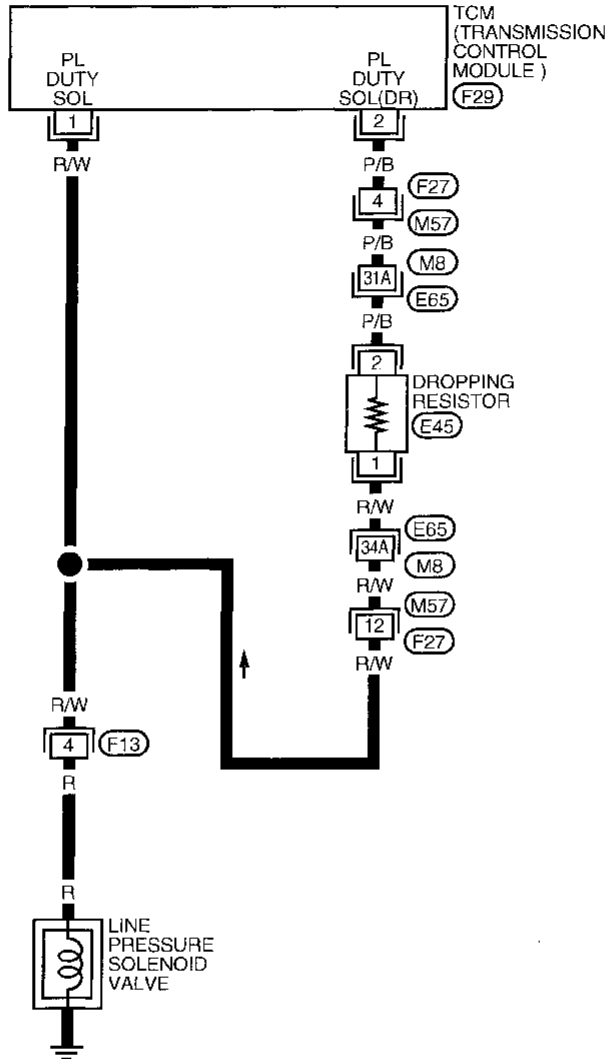

GI
 MA
 EM
 LC
 EC
 FE
 CL
 MT
AT
 FA
 RA
 BR
 ST
 RS
 BT
 HA
 EL
 IDX

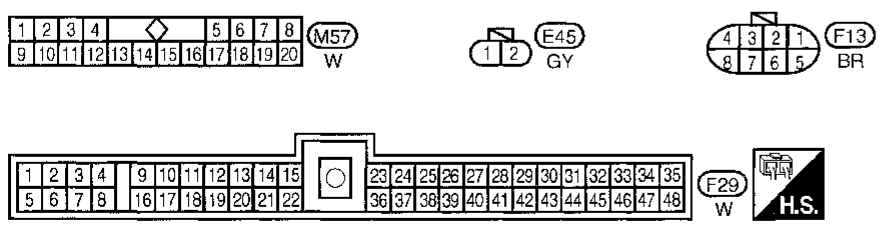

Refer to last page (Foldout page).
 (M8), (E65)

TROUBLE DIAGNOSIS FOR DTC P0745

Line Pressure Solenoid Valve (Cont'd)

DIAGNOSTIC PROCEDURE

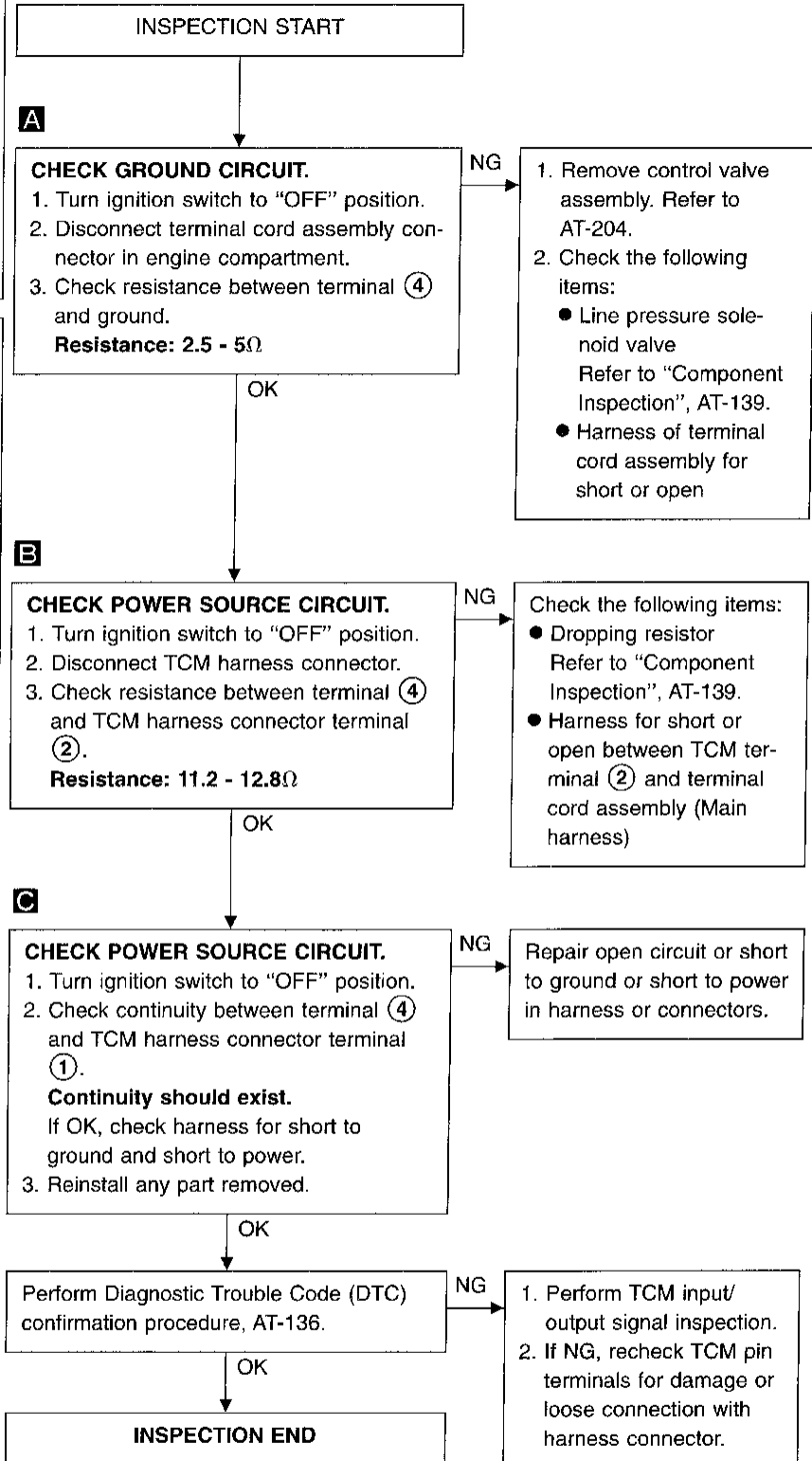
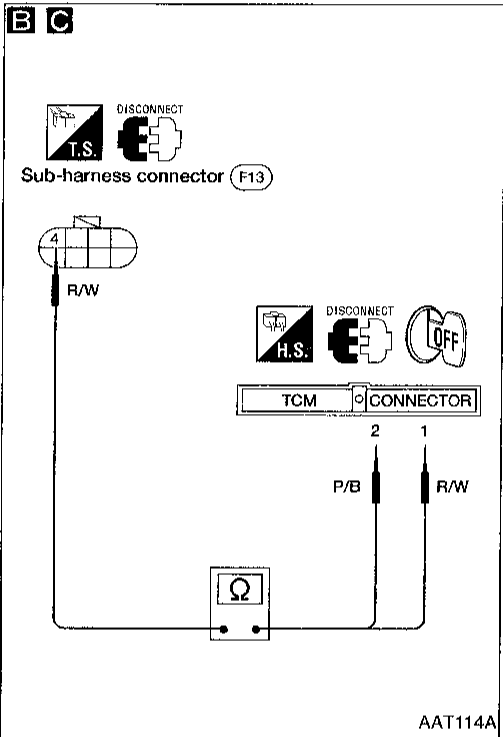
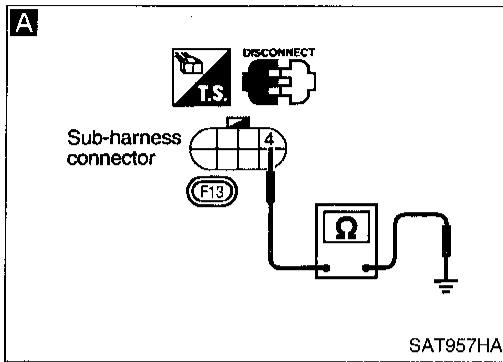

TROUBLE DIAGNOSIS FOR DTC P0745

Line Pressure Solenoid Valve (Cont'd)

COMPONENT INSPECTION

Line pressure solenoid valve

- For removal, refer to AT-204.

Resistance check

- Check resistance between two terminals.

Solenoid valve	Terminal No.		Resistance (Approx.)
Line pressure solenoid valve	④	Ground	2.5 - 5Ω

GI

MA

EM

LC

EC

FE

CL

MT

AT

FA

RA

BR

ST

RS

BT

HA

EL

IDX

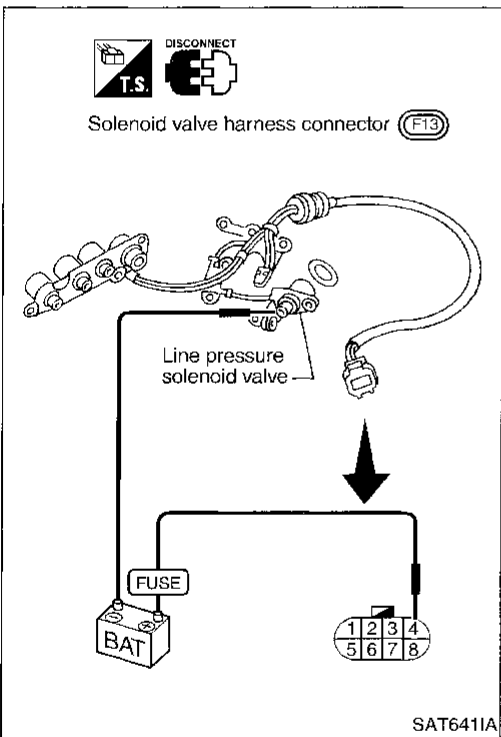
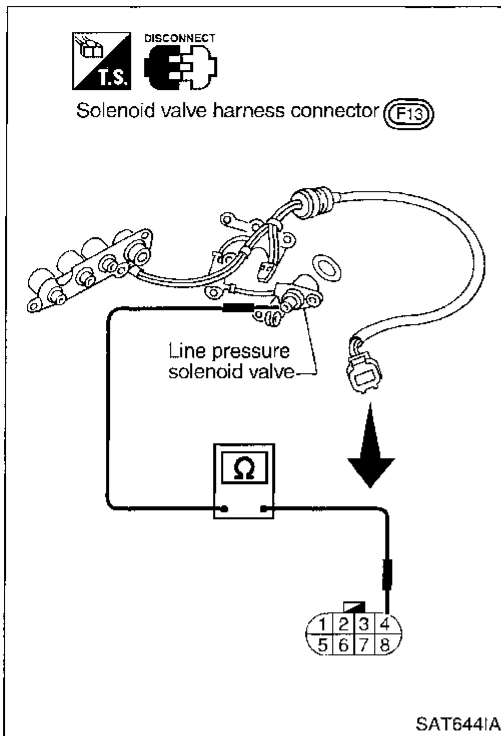

Operation check

- Check solenoid valve by listening for its operating sound while applying battery voltage to the terminal and ground.

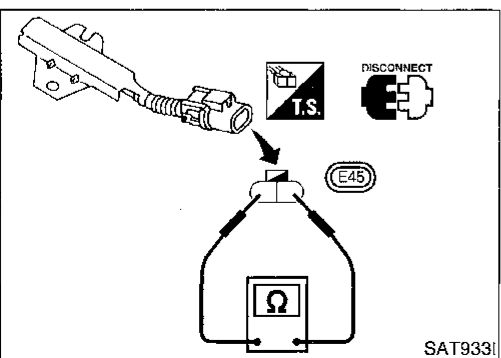

Dropping resistor

- Check resistance between two terminals.
Resistance: 11.2 - 12.8Ω

TROUBLE DIAGNOSIS FOR DTC P0750

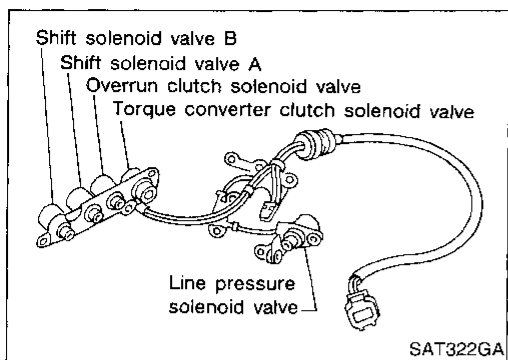

Shift Solenoid Valve A

DESCRIPTION

Shift solenoid valves A and B are turned "ON" or "OFF" by the TCM in response to signals sent from the inhibitor switch, vehicle speed and throttle position sensors. Gears will then be shifted to the optimum position.



Gear position	1	2	3	4
Shift solenoid valve A	ON (Closed)	OFF (Open)	OFF (Open)	ON (Closed)
Shift solenoid valve B	ON (Closed)	ON (Closed)	OFF (Open)	OFF (Open)

TCM TERMINALS AND REFERENCE VALUE

Remarks: Specification data are reference values.

Terminal No.	Wire color	Item	Condition	Judgement standard
6	L/W	Shift solenoid valve A	 When shift solenoid valve A operates. (When driving in "D ₁ " or "D ₄ ".)	Battery voltage
			When shift solenoid valve A does not operate. (When driving in "D ₂ " or "D ₃ ".)	1V or less

ON BOARD DIAGNOSIS LOGIC

Diagnostic trouble code	Malfunction is detected when ...	Check item (Possible cause)
 : SFT SOL A/CIRC  : P0750  : MIL Code No. 1108	TCM detects an improper voltage drop when it tries to operate the solenoid valve.	<ul style="list-style-type: none"> ● Harness or connectors (The solenoid circuit is open or shorted.) ● Shift solenoid valve A

TROUBLE DIAGNOSIS FOR DTC P0750

Shift Solenoid Valve A (Cont'd)

DIAGNOSTIC TROUBLE CODE (DTC) CONFIRMATION PROCEDURE

CAUTION:

- Always drive vehicle at a safe speed.
- If conducting this "DTC CONFIRMATION PROCEDURE" again, always turn ignition switch "OFF" and wait at least 5 seconds before continuing.

After the repair, perform the following procedure to confirm the malfunction is eliminated.

Diagram of CONSULT screen showing the 'SELECT SYSTEM' menu. The 'ENGINE' option is selected and highlighted. Below it are five empty menu slots. The diagram is labeled 'SEF895K'.

Diagram of CONSULT screen showing the 'SELECT DIAG MODE' menu. The 'DTC CONFIRMATION' option is selected and highlighted. Other options include 'WORK SUPPORT', 'SELF-DIAG RESULTS', 'DATA MONITOR', 'ACTIVE TEST', and 'ECM PART NUMBER'. The diagram is labeled 'SAT911I'.

- 1) Turn ignition switch "ON" and select "DATA MONITOR" mode for "ENGINE" with CONSULT.
 2) Start engine.
 3) Drive vehicle in D position and allow the transmission to shift "1" → "2" ("GEAR").

OR

- 1) Start engine.
 2) Drive vehicle in D₁ → D₂ position.
 3) Select "MODE 7" with GST.

OR

- 1) Start engine.
 2) Drive vehicle in D₁ → D₂ position.
 3) Perform self-diagnosis for ECM.

Refer to EC section ["Malfunction Indicator Lamp (MIL)", "ON BOARD DIAGNOSTIC SYSTEM DESCRIPTION"].

GI

MA

EM

LC

EC

FE

CL

MT

AT

FA

RA

BR

ST

RS

BT

HA

EL

IDX

TROUBLE DIAGNOSIS FOR DTC P0750

Shift Solenoid Valve A (Cont'd)

WIRING DIAGRAM — AT — SSV/A

AT-SSV/A-01

— : Detectable line for DTC
 — : Non-detectable line for DTC

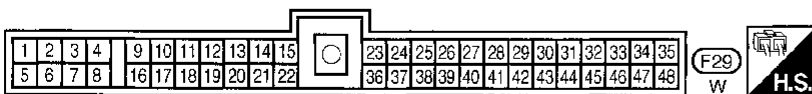
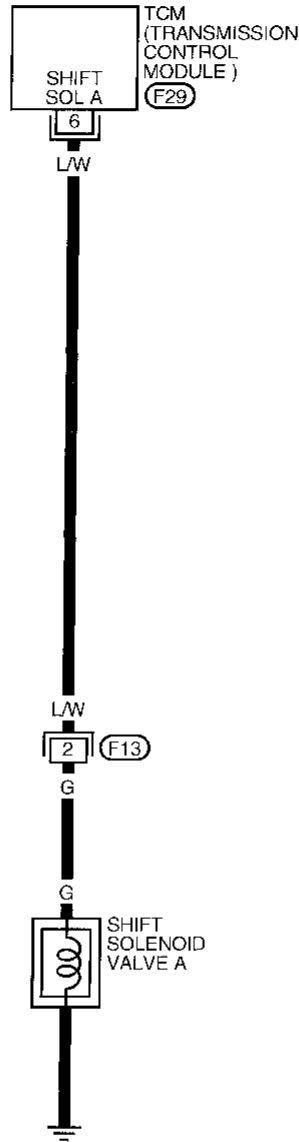

TROUBLE DIAGNOSIS FOR DTC P0750

Shift Solenoid Valve A (Cont'd)

DIAGNOSTIC PROCEDURE

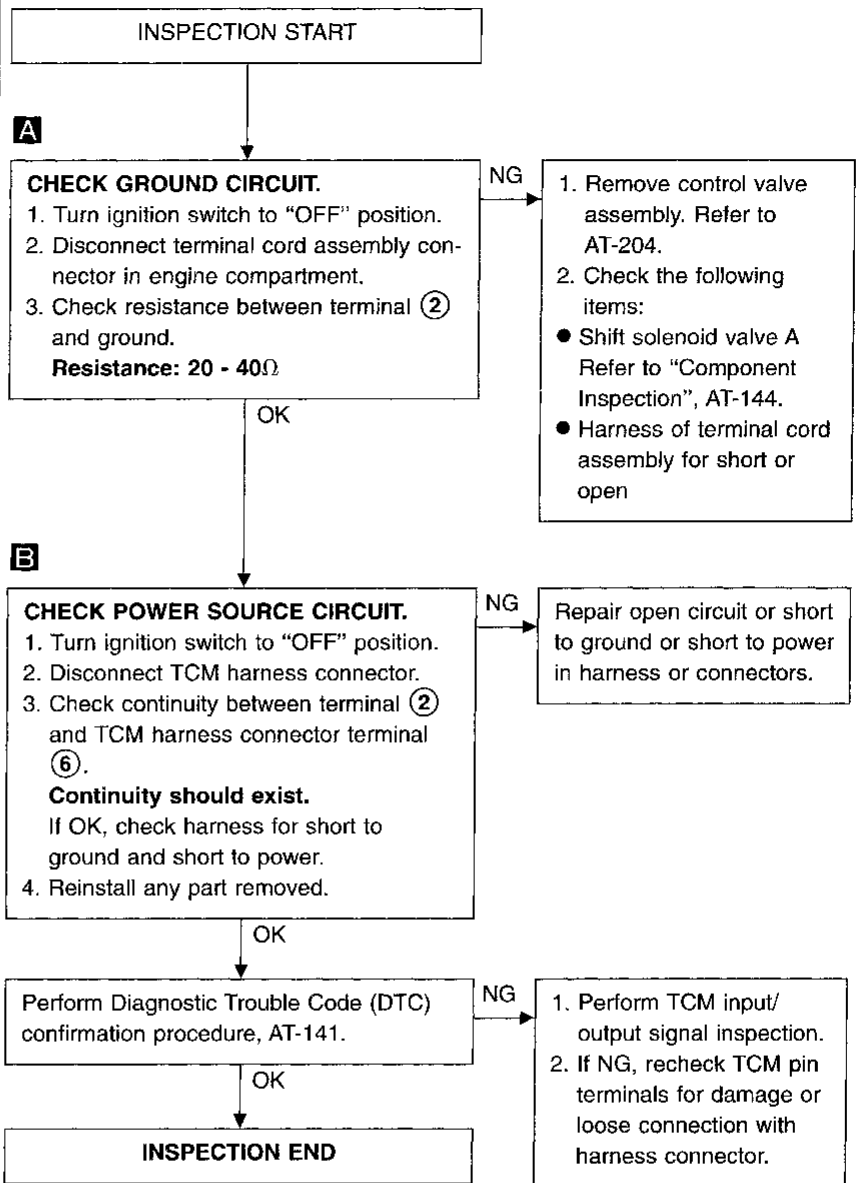
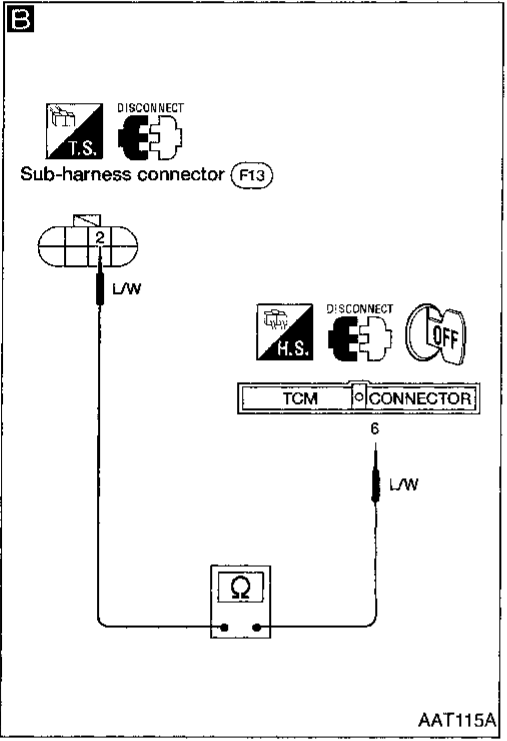
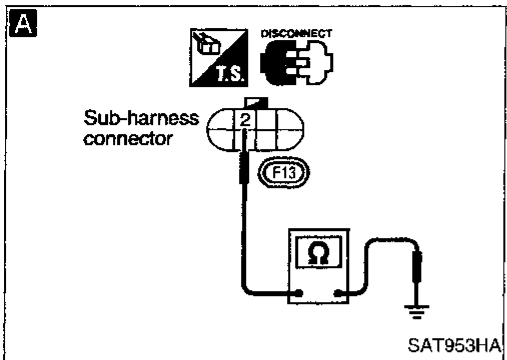

GI
MA
EM
LC
EC
FE
CL
MT
AT
FA
RA
BR
ST
RS
BT
HA
EL
IDX

TROUBLE DIAGNOSIS FOR DTC P0750

Shift Solenoid Valve A (Cont'd)

COMPONENT INSPECTION

Shift solenoid valve A

- For removal, refer to AT-204.

Resistance check

- Check resistance between two terminals.

Solenoid valve	Terminal No.		Resistance (Approx.)
Shift solenoid valve A	②	Ground	20 - 40Ω

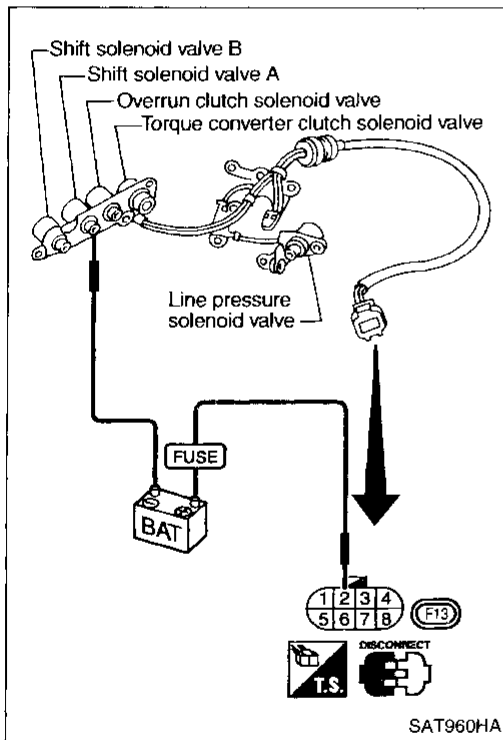
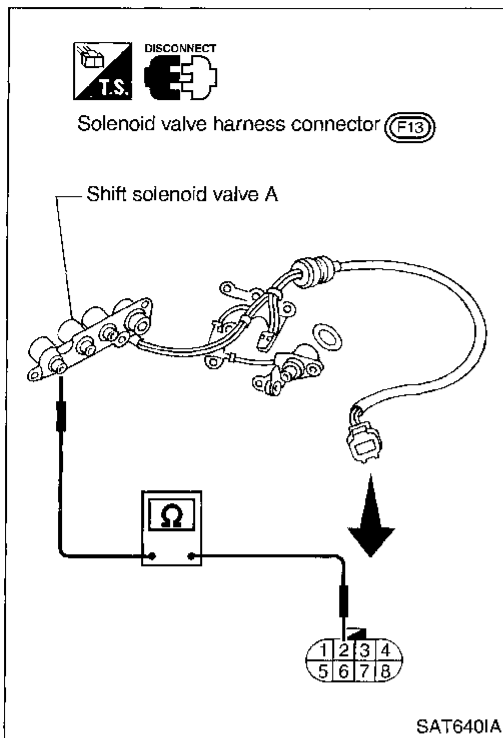

Operation check

- Check solenoid valve by listening for its operating sound while applying battery voltage to the terminal and ground.

TROUBLE DIAGNOSIS FOR DTC P0755

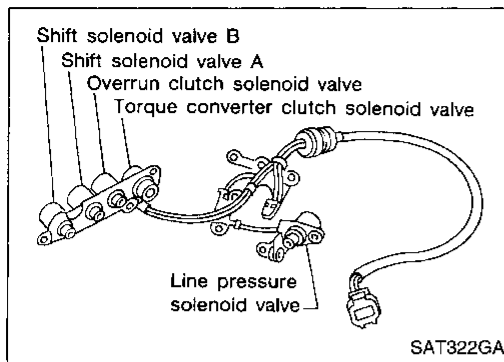

Shift Solenoid Valve B

DESCRIPTION

Shift solenoid valves A and B are turned "ON" or "OFF" by the TCM in response to signals sent from the inhibitor switch, vehicle speed and throttle position sensors. Gears will then be shifted to the optimum position.



Gear position	1	2	3	4
Shift solenoid valve A	ON (Closed)	OFF (Open)	OFF (Open)	ON (Closed)
Shift solenoid valve B	ON (Closed)	ON (Closed)	OFF (Open)	OFF (Open)

TCM TERMINALS AND REFERENCE VALUE

Remarks: Specification data are reference values.

Terminal No.	Wire color	Item	Condition	Judgement standard
7	LY	Shift solenoid valve B	 When shift solenoid valve B operates. (When driving in "D ₁ " or "D ₂ ".)	Battery voltage
			When shift solenoid valve B does not operate. (When driving in "D ₃ " or "D ₄ ".)	1V or less

ON BOARD DIAGNOSIS LOGIC

Diagnostic trouble code	Malfunction is detected when ...	Check item (Possible cause)
 : SFT SOL B/CIRC  : P0755  : MIL Code No. 1201	TCM detects an improper voltage drop when it tries to operate the solenoid valve.	<ul style="list-style-type: none"> ● Harness or connectors (The solenoid circuit is open or shorted.) ● Shift solenoid valve B

TROUBLE DIAGNOSIS FOR DTC P0755

Shift Solenoid Valve B (Cont'd)

DIAGNOSTIC TROUBLE CODE (DTC) CONFIRMATION PROCEDURE

CAUTION:

- Always drive vehicle at a safe speed.
- If conducting this "DTC CONFIRMATION PROCEDURE" again, always turn ignition switch "OFF" and wait at least 5 seconds before continuing.

After the repair, perform the following procedure to confirm the malfunction is eliminated.

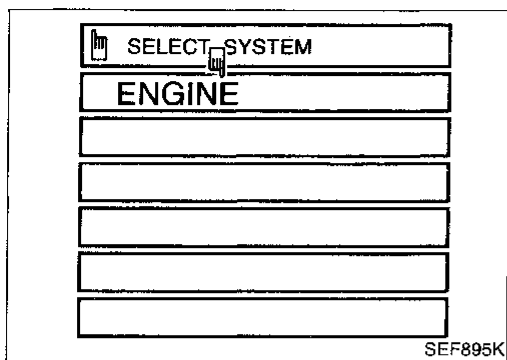

- 1) Turn ignition switch "ON" and select "DATA MONITOR" mode for "ENGINE" with CONSULT.
- 2) Start engine.
- 3) Drive vehicle in D position and allow the transmission to shift 1 → 2 → 3 ("GEAR").

OR



- 1) Start engine.
- 2) Drive vehicle in D₁ → D₂ → D₃ position.
- 3) Select "MODE 7" with GST.

OR



- 1) Start engine.
- 2) Drive vehicle in D₁ → D₂ → D₃ position.
- 3) Perform self-diagnosis for ECM.

Refer to EC section ["Malfunction Indicator Lamp (MIL)", "ON BOARD DIAGNOSTIC SYSTEM DESCRIPTION"].

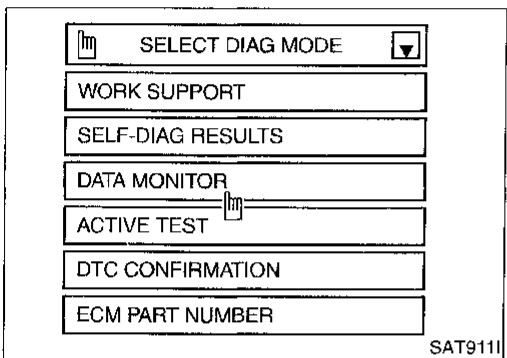

TROUBLE DIAGNOSIS FOR DTC P0755

Shift Solenoid Valve B (Cont'd) WIRING DIAGRAM — AT — SSV/B

AT-SSV/B-01

— : Detectable line for DTC
— : Non-detectable line for DTC

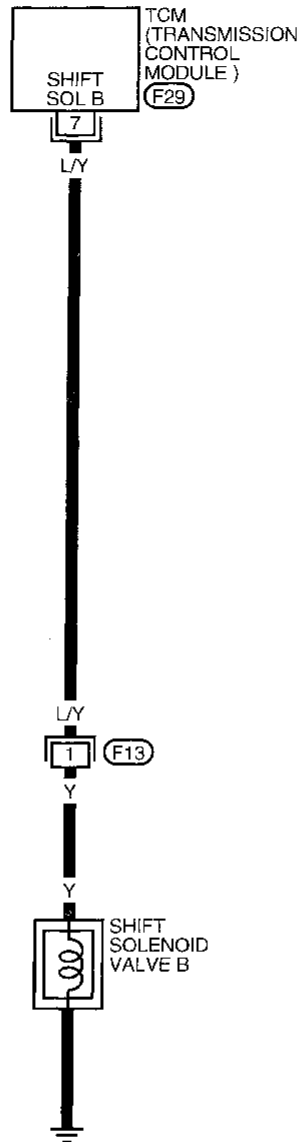

GI

MA

EM

LC

EC

FE

CL

MT

AT

FA

RA

BR

ST

RS

BT

HA

EL

IDX

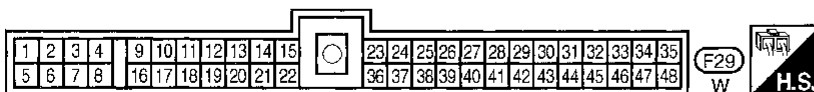

TROUBLE DIAGNOSIS FOR DTC P0755

Shift Solenoid Valve B (Cont'd)

DIAGNOSTIC PROCEDURE

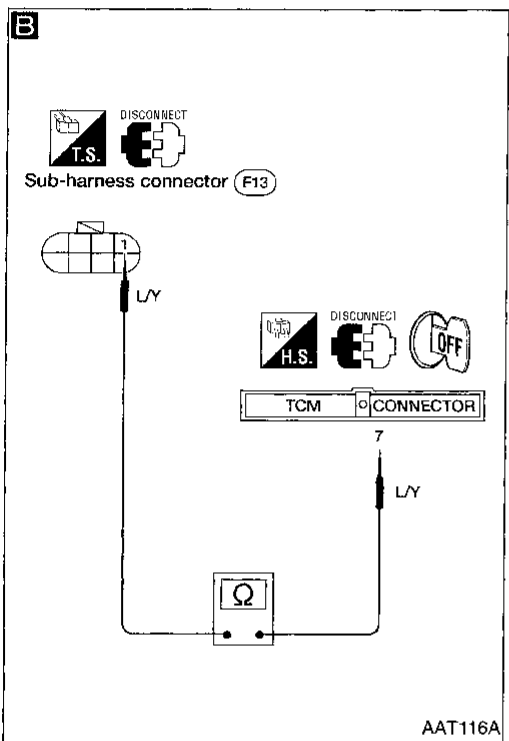
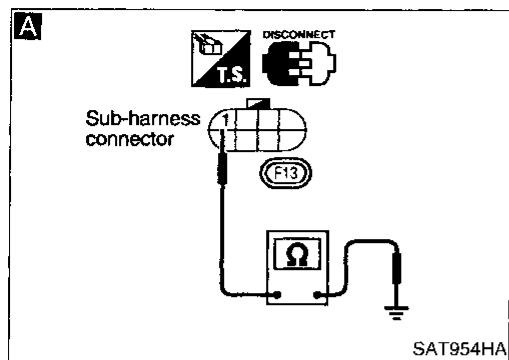

INSPECTION START

A

CHECK GROUND CIRCUIT.

1. Turn ignition switch to "OFF" position.
2. Disconnect terminal cord assembly connector in engine compartment.
3. Check resistance between terminal ① and ground.

Resistance: 20 - 40Ω

NG

1. Remove control valve assembly. Refer to AT-204.
2. Check the following items:
 - Shift solenoid valve B
 - Refer to "Component Inspection", AT-149.
 - Harness of terminal cord assembly for short or open

OK

B

CHECK POWER SOURCE CIRCUIT.

1. Turn ignition switch to "OFF" position.
2. Disconnect TCM harness connector.
3. Check continuity between terminal ① and TCM harness connector terminal ⑦.

Continuity should exist.

If OK, check harness for short to ground and short to power.

4. Reinstall any part removed.

NG

Repair open circuit or short to ground or short to power in harness or connectors.

OK

Perform Diagnostic Trouble Code (DTC) confirmation procedure, AT-146.

NG

1. Perform TCM input/output signal inspection.
2. If NG, recheck TCM pin terminals for damage or loose connection with harness connector.

OK

INSPECTION END

TROUBLE DIAGNOSIS FOR DTC P0755

Shift Solenoid Valve B (Cont'd)

COMPONENT INSPECTION

Shift solenoid valve B

- For removal, refer to AT-204.

Resistance check

- Check resistance between two terminals.

Solenoid valve	Terminal No.		Resistance (Approx.)
Shift solenoid valve B	①	Ground	20 - 40Ω

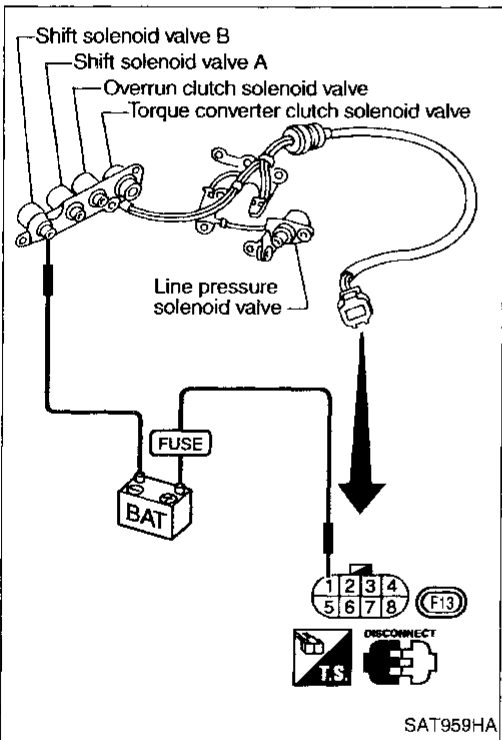
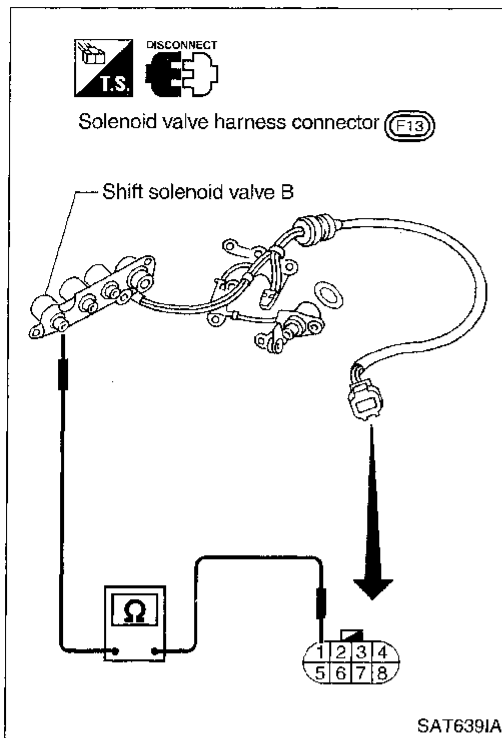

Operation check

- Check solenoid valve by listening for its operating sound while applying battery voltage to the terminal and ground.

GI

MA

EM

LC

EC

FE

CL

MT

AT

FA

RA

BR

ST

RS

BT

HA

EL

IDX

TROUBLE DIAGNOSIS FOR DTC P1705

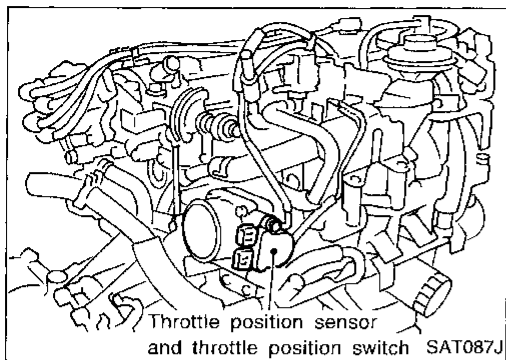

Throttle Position Sensor

DESCRIPTION

- Throttle position sensor
The throttle position sensor detects the throttle valve position and sends a signal to the TCM.
- Throttle position switch
Consists of a wide open throttle position switch and a closed throttle position switch.
The wide open throttle position switch sends a signal to the TCM when the throttle valve is open at least 1/2 of the full throttle position. The closed throttle position switch sends a signal to the TCM when the throttle valve is fully closed.

CONSULT REFERENCE VALUE IN DATA MONITOR MODE

Remarks: Specification data are reference values.

Monitor item	Condition	Specification
Throttle position sensor	Fully-closed throttle	Approximately 0.5V
	Fully-open throttle	Approximately 4V

TCM TERMINALS AND REFERENCE VALUE



Remarks: Specification data are reference values.

Terminal No.	Wire color	Item	Condition	Judgement standard
14	Y	Closed throttle position switch (in throttle position switch)	When releasing accelerator pedal after warming up engine.	Battery voltage
			When depressing accelerator pedal after warming up engine.	1V or less
21	LG	Wide open throttle position switch (in throttle position switch)	When depressing accelerator pedal more than half-way after warming up engine.	Battery voltage
			When releasing accelerator pedal after warming up engine.	1V or less
31	R	Throttle position sensor (Power source)	—	4.5 - 5.5V
34	GY	Throttle position sensor	When depressing accelerator pedal slowly after warming up engine. (Voltage rises gradually in response to throttle position.)	Fully-closed throttle: Approximately 0.5V Fully-open throttle: Approximately 4V
35	B	Throttle position sensor (Ground)	—	—

TROUBLE DIAGNOSIS FOR DTC P1705

Throttle Position Sensor (Cont'd)

ON BOARD DIAGNOSIS LOGIC

Diagnostic trouble code	Malfunction is detected when ...	Check item (Possible cause)	
 : TP SEN/CIRC A/T  : P1705  : MIL Code No. 1206	TCM receives an excessively low or high voltage from the sensor.	<ul style="list-style-type: none"> ● Harness or connectors (The sensor circuit is open or shorted.) ● Throttle position sensor ● Throttle position switch 	GI MA EM

LC

EC

FE

CL

MT

AT

FA

RA

BR

ST

RS

BT

HA

EL

IDX

TROUBLE DIAGNOSIS FOR DTC P1705

Throttle Position Sensor (Cont'd)

DIAGNOSTIC TROUBLE CODE (DTC) CONFIRMATION PROCEDURE

CAUTION:

- Always drive vehicle at a safe speed.
- If conducting this "DTC CONFIRMATION PROCEDURE" again, always turn ignition switch "OFF" and wait at least 5 seconds before continuing.

After the repair, perform the following procedure to confirm the malfunction is eliminated.

- 1) Turn ignition switch "ON" and select "DATA MONITOR" mode for "A/T" with CONSULT.
- 2) Check the following.

Accelerator pedal condition	THRTL POS SEN	CLOSED THL/SW	W/O THRL/P-SW
Fully released	Less than 4.7V	ON	OFF
Partially depressed	0.1 - 4.6V	OFF	OFF
Fully depressed	More than 0.1V	OFF	ON

If the check result is NG, go to "DIAGNOSTIC PROCEDURE", AT-154.

If the check result is OK, go to following step.

- 3) Turn ignition switch "ON" and select "DATA MONITOR" mode for "ENGINE" with CONSULT.
- 4) Start engine and maintain the following conditions for at least 3 consecutive seconds.

VHCL SPEED SE: 10 km/h (6 MPH) or more

THRTL POS SEN: Approximately 3V or less

Selector lever: D position (OD "ON")

If the check result is NG, go to "DIAGNOSTIC PROCEDURE", AT-154.

If the check result is OK, go to following step.

- 5) Maintain the following conditions for at least 3 consecutive seconds.

VHCL SPEED SE: 10 km/h (6 MPH) or more

Accelerator pedal: Wide open throttle

Selector lever: D position (OD "ON")

OR



- 1) Start engine.
- 2) Drive vehicle under the following conditions:
Selector lever in "D" (OD "ON"), vehicle speed higher than 10 km/h (6 MPH), throttle opening greater than 1/2 of the full throttle position and driving for more than 3 seconds.
- 3) Select "MODE 7" with GST.

OR



- 1) Start engine.
- 2) Drive vehicle under the following conditions:
Selector lever in "D" (OD "ON"), vehicle speed higher than 10 km/h (6 MPH), throttle opening greater than 1/2 of the full throttle position and driving for more than 3 seconds.
- 3) Perform self-diagnosis for ECM.
Refer to EC section ["Malfunction Indicator Lamp (MIL)", "ON BOARD DIAGNOSTIC SYSTEM DESCRIPTION"].

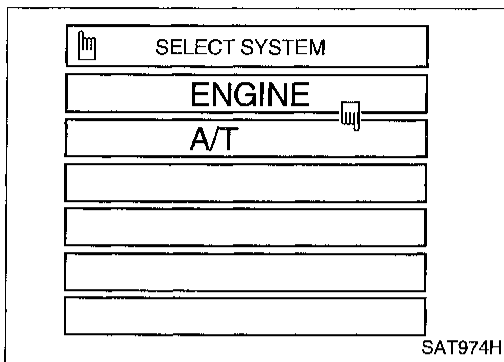

SAT974H

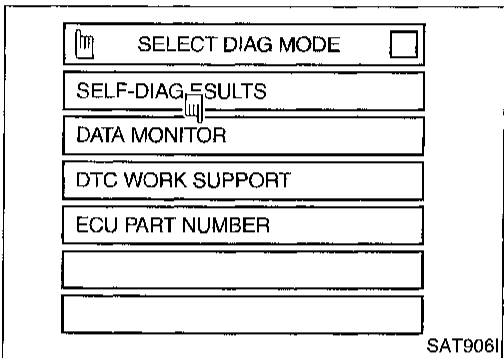

SAT906I

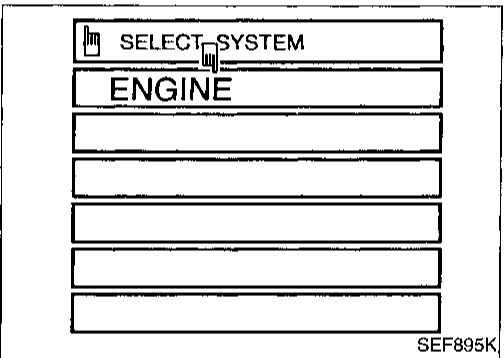

SEF895K

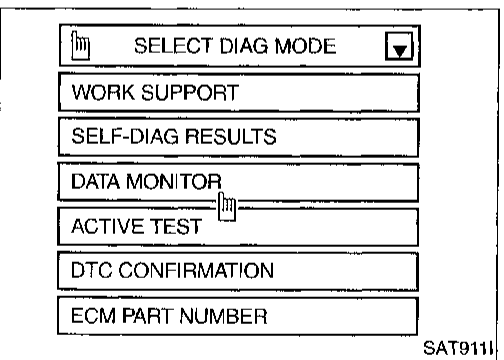

SAT911I

TROUBLE DIAGNOSIS FOR DTC P1705

Throttle Position Sensor (Cont'd) WIRING DIAGRAM — AT — TPS

AT-TPS-01

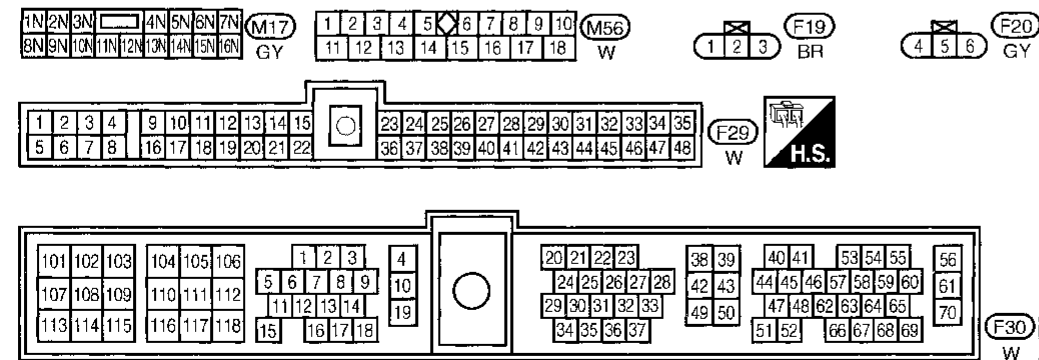
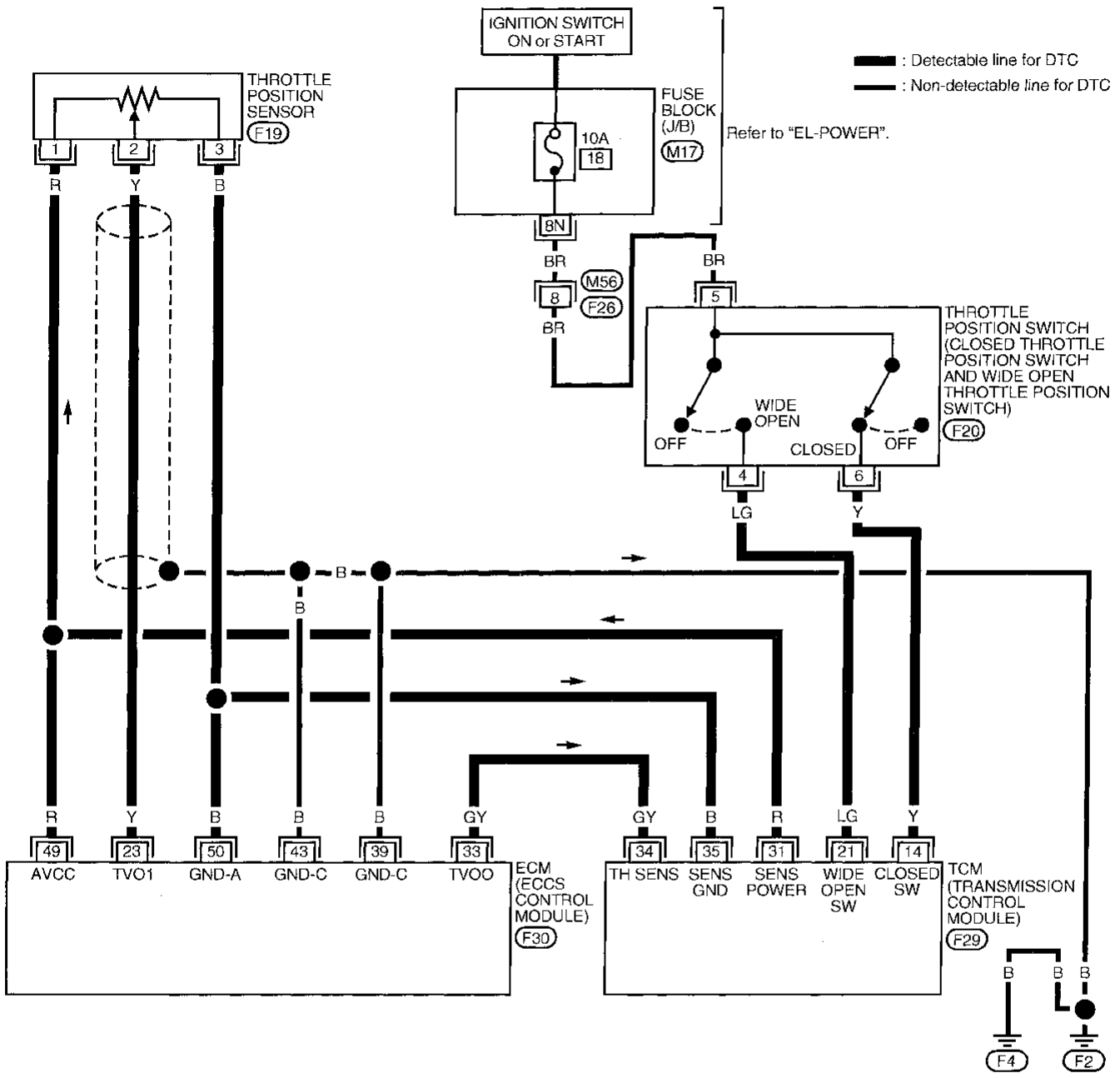

GI
MA
EM
LC
EC
FE
CL
WT
AT
FA
RA
BR
ST
RS
BT
HA
EL
IOX

TROUBLE DIAGNOSIS FOR DTC P1705

Throttle Position Sensor (Cont'd)

DIAGNOSTIC PROCEDURE

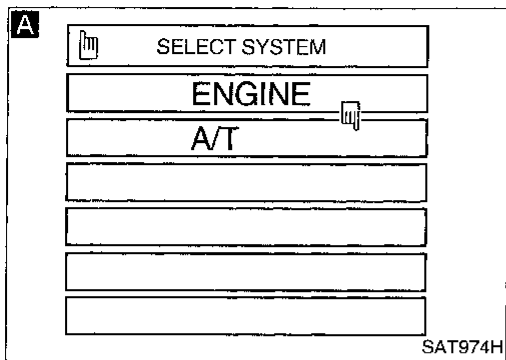

INSPECTION START

Perform diagnostic test mode II (self-diagnostic results) for engine control. Refer to EC section ["Malfunction Indicator Lamp (MIL)", "ON BOARD DIAGNOSTIC SYSTEM DESCRIPTION"].

NG

Check throttle position sensor circuit for engine control. Refer to EC section ["Throttle Position Sensor (DTC: 0403)", "TROUBLE DIAGNOSIS FOR DTC P0120"].

OK

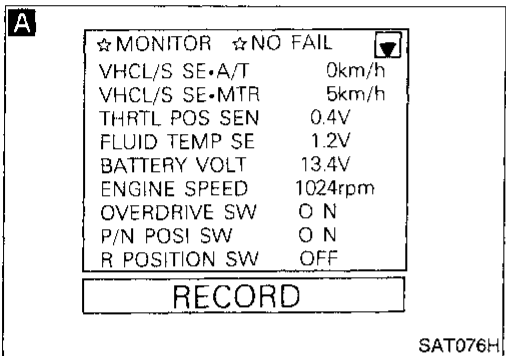

A

CHECK INPUT SIGNAL.



1. Turn ignition switch to "ON" position. (Do not start engine.)
2. Select "ECU INPUT SIGNALS" in "DATA MONITOR" mode for "A/T" with CONSULT.
3. Read out the value of "THRTL POS SEN".

Voltage:

Fully-closed throttle:
Approximately 0.5V
Fully-open throttle:
Approximately 4V

OR



1. Turn ignition switch to "ON" position. (Do not start engine.)
2. Check voltage between TCM terminals ③④ and ③⑤ while accelerator pedal is depressed slowly.

Voltage:

Fully-closed throttle valve:
Approximately 0.5V
Fully-open throttle valve:
Approximately 4V
(Voltage rises gradually in response to throttle position)

NG

Check harness for short or open between ECM and TCM regarding throttle position sensor circuit. (Main harness)

OK

A

(Go to next page.)

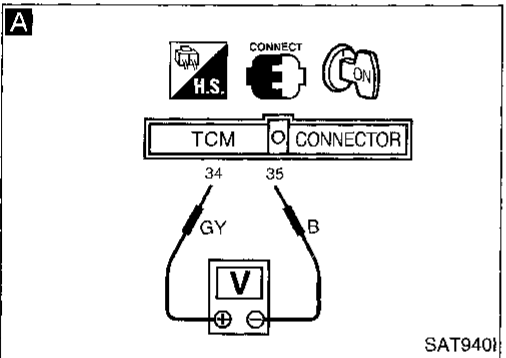

TROUBLE DIAGNOSIS FOR DTC P1705

Throttle Position Sensor (Cont'd)

C

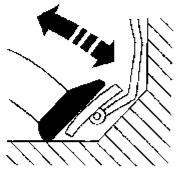

☆ MONITOR	☆ NO FAIL	
D POSITION SW	OFF	
2 POSITION SW	OFF	
1 POSITION SW	OFF	
ASCD • CRUISE	OFF	
ASCD • OD CUT	OFF	
KICKDOWN SW	OFF	
POWERSHIFT SW	OFF	
CLOSED THL/SW	ON	
W/O THRL/P-SW	OFF	

RECORD

SAT963H

C

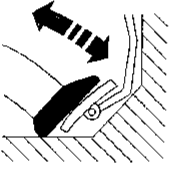
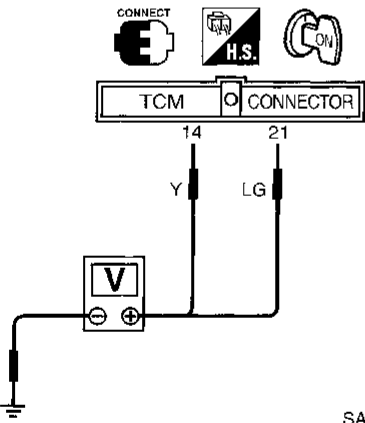
CONNECT E H.S. ON

TCM CONNECTOR

14 21

Y LG

V

SAT945I

A

C

CHECK THROTTLE POSITION SWITCH CIRCUIT.

- Turn ignition switch to "ON" position. (Do not start engine.)
- Select "ECU INPUT SIGNALS" in "DATA MONITOR" mode for "A/T" with CONSULT.
- Read out "CLOSED THL/SW" and "W/O THRL/P-SW" depressing and releasing accelerator pedal.

Check the signal of throttle position switch is indicated properly.

Accelerator pedal condition	Data monitor	
	CLOSED THL/SW	W/O THRL/P-SW
Released	ON	OFF
Fully depressed	OFF	ON

OR

- Turn ignition switch to "ON" position. (Do not start engine.)
- Check voltage between TCM terminals (14), (21) and ground while depressing, and releasing accelerator pedal slowly. (After warming up engine)

Accelerator pedal condition	Voltage	
	Terminal No. (14)	Terminal No. (21)
Released	Battery voltage	1V or less
Fully depressed	1V or less	Battery voltage

NG

Check the following items:

- Throttle position switch — Refer to "Components Inspection", AT-156.
- Harness for short or open between ignition switch and throttle position switch (Main harness)
- Harness for short or open between throttle position switch and TCM (Main harness)

OK

Perform Diagnostic Trouble Code (DTC) confirmation procedure, AT-152.

OK

INSPECTION END

NG

- Perform TCM input/output signal inspection.
- If NG, recheck TCM pin terminals for damage or loose connection with harness connector.

GI
MA
EM
LC
EC
FE
CL
MT
AT
FA
RA
BR
ST
RS
BT
HA
EL
IDX

TROUBLE DIAGNOSIS FOR DTC P1705

Throttle Position Sensor (Cont'd)

COMPONENT INSPECTION

Throttle position switch

Closed throttle position switch (idle position)

- Check continuity between terminals ⑤ and ⑥.

Accelerator pedal condition	Continuity
Released	Yes
Depressed	No

- To adjust closed throttle position switch, refer to EC section ("Basic Inspection", "TROUBLE DIAGNOSIS — Basic Inspection").

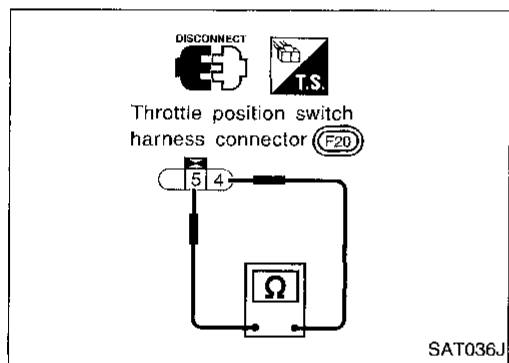
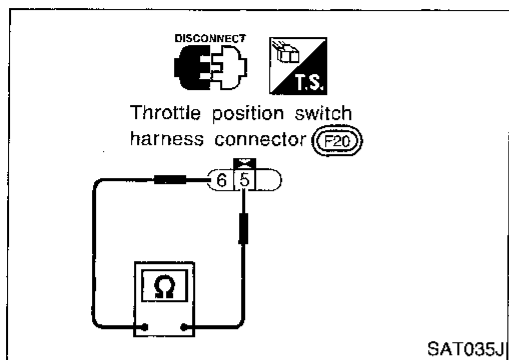

Wide open throttle position switch

- Check continuity between terminals ④ and ⑤.

Accelerator pedal condition	Continuity
Released	No
Depressed	Yes

TROUBLE DIAGNOSIS FOR DTC P1760

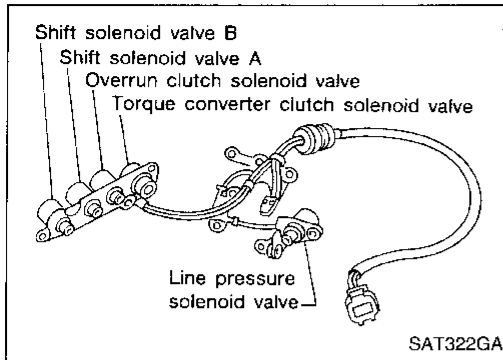

Overrun Clutch Solenoid Valve

DESCRIPTION



The overrun clutch solenoid valve is activated by the TCM in response to signals sent from the inhibitor switch, overdrive control switch, vehicle speed and throttle position sensors. The overrun clutch operation will then be controlled.

TCM TERMINALS AND REFERENCE VALUE

Remarks: Specification data are reference values.

Terminal No.	Wire color	Item	Condition	Judgement standard
8	L/B	Overrun clutch solenoid valve	 When overrun clutch solenoid valve operates.	Battery voltage
			When overrun clutch solenoid valve does not operate.	1V or less

ON BOARD DIAGNOSIS LOGIC

Diagnostic trouble code	Malfunction is detected when ...	Check item (Possible cause)
 : O/R CLTCH SOL/CIRC  : P1760  : MIL Code No. 1203	TCM detects an improper voltage drop when it tries to operate the solenoid valve.	<ul style="list-style-type: none"> ● Harness or connectors (The solenoid circuit is open or shorted.) ● Overrun clutch solenoid valve

TROUBLE DIAGNOSIS FOR DTC P1760

Overrun Clutch Solenoid Valve (Cont'd)

DIAGNOSTIC TROUBLE CODE (DTC) CONFIRMATION PROCEDURE

CAUTION:

- Always drive vehicle at a safe speed.
- If conducting this "DTC CONFIRMATION PROCEDURE" again, always turn ignition switch "OFF" and wait at least 5 seconds before continuing.

NOTE:

Always drive vehicle on a level road to improve accuracy of test.

After the repair, perform the following procedure to confirm the malfunction is eliminated.

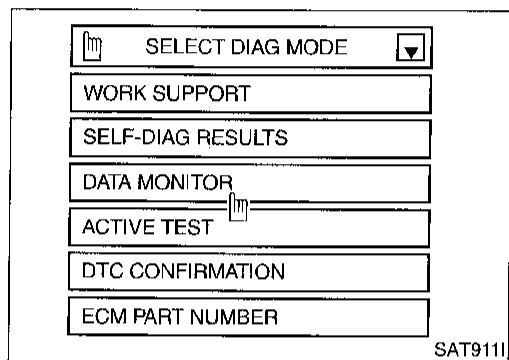
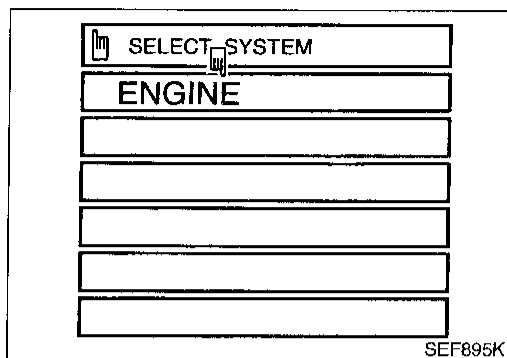

- 1) Turn ignition switch "ON" and select "DATA MONITOR" mode for "ENGINE" with CONSULT.
- 2) Start engine and drive the vehicle under the following conditions.

VHCL SPEED SE: 10 km/h (6 MPH) or more
Selector lever: D position (OD "ON" or "OFF")

OR

- 1) Start engine.
- 2) Drive vehicle under the following conditions:
Selector lever in "D", overdrive control switch in "ON" or "OFF" position and vehicle speed higher than 10 km/h (6 MPH).
- 3) Select "MODE 7" with GST.

OR

- 1) Start engine.
- 2) Drive vehicle under the following conditions:
Selector lever in "D", overdrive control switch in "ON" or "OFF" position and vehicle speed higher than 10 km/h (6 MPH).
- 3) Perform self-diagnosis for ECM.
Refer to EC section ["Malfunction Indicator Lamp (MIL)", "ON BOARD DIAGNOSTIC SYSTEM DESCRIPTION"].

TROUBLE DIAGNOSIS FOR DTC P1760

Overrun Clutch Solenoid Valve (Cont'd) WIRING DIAGRAM — AT — OVRCSV

AT-OVRCSV-01

GI

— : Detectable line for DTC
— : Non-detectable line for DTC

MA

EM

LC

EC

FE

CL

MT

AT

FA

RA

BR

ST

RS

BT

HA

EL

IDX

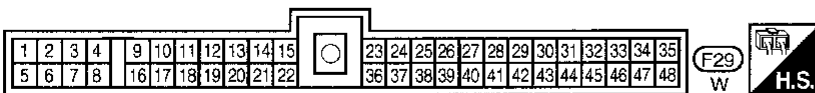
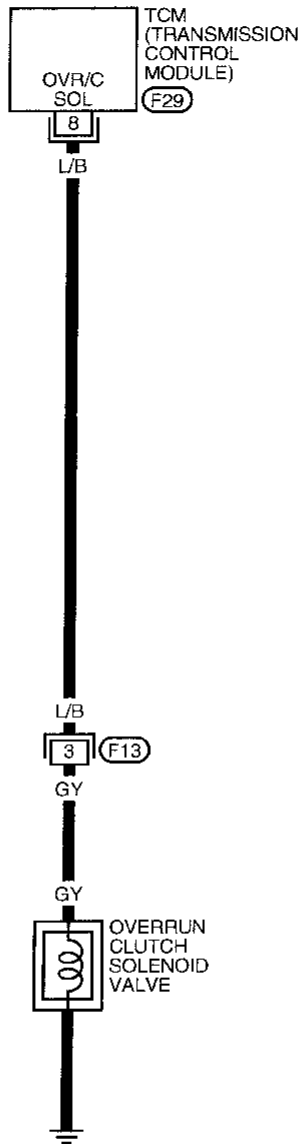

TROUBLE DIAGNOSIS FOR DTC P1760

Overrun Clutch Solenoid Valve (Cont'd)

DIAGNOSTIC PROCEDURE

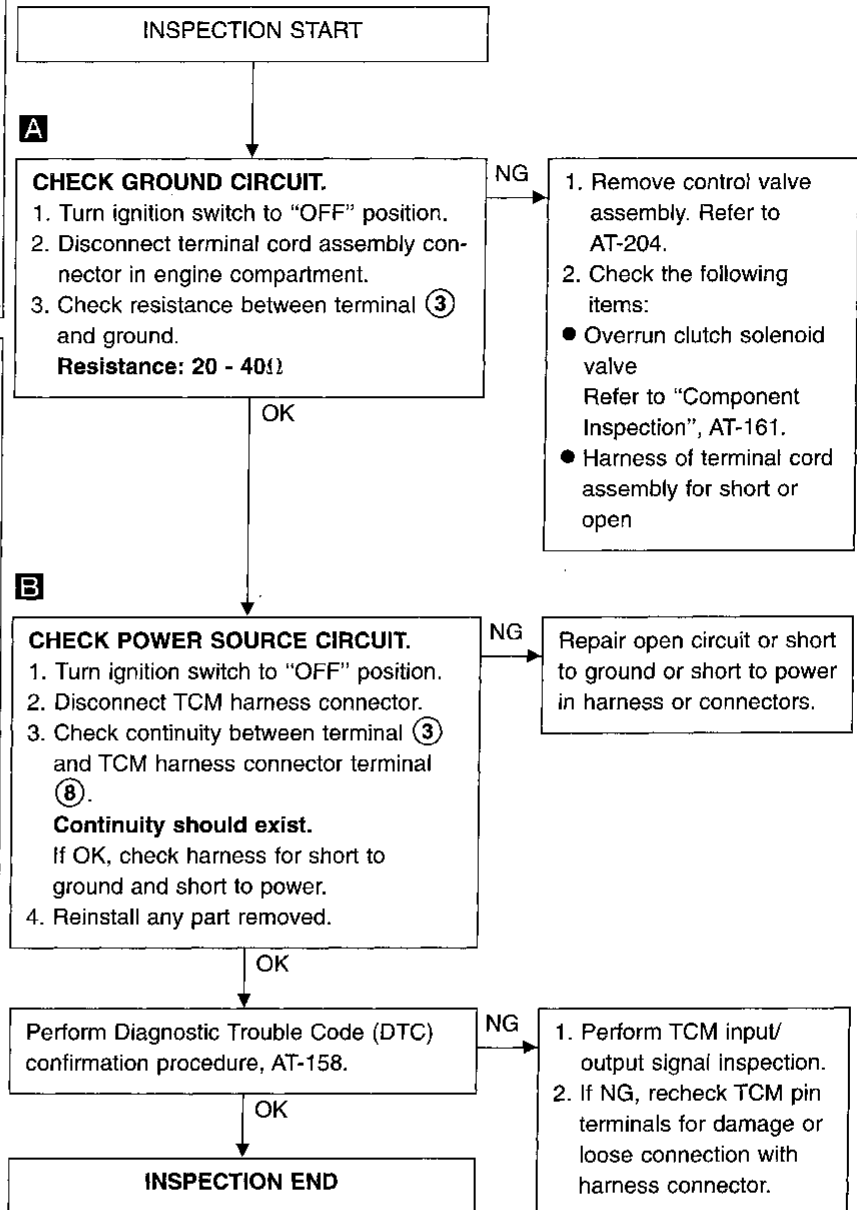
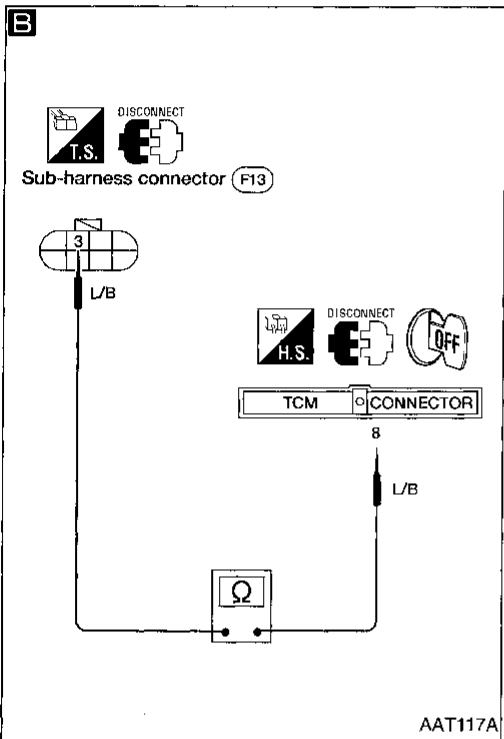
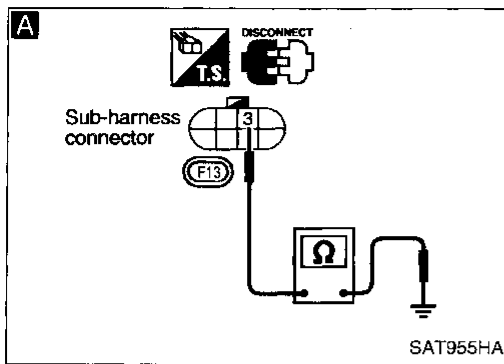

TROUBLE DIAGNOSIS FOR DTC P1760

Overrun Clutch Solenoid Valve (Cont'd)

COMPONENT INSPECTION

Overrun clutch solenoid valve

- For removal, refer to AT-204.

Resistance check

- Check resistance between two terminals.

Solenoid valve	Terminal No.		Resistance (Approx.)
Overrun clutch solenoid valve	③	Ground	20 - 40Ω

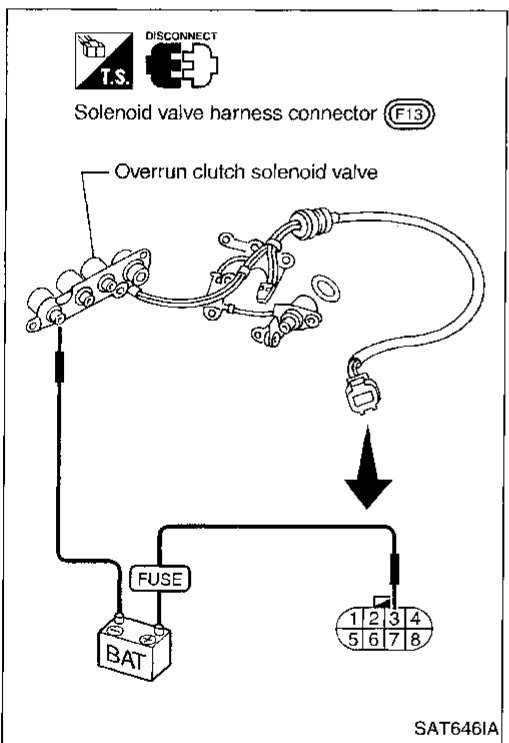
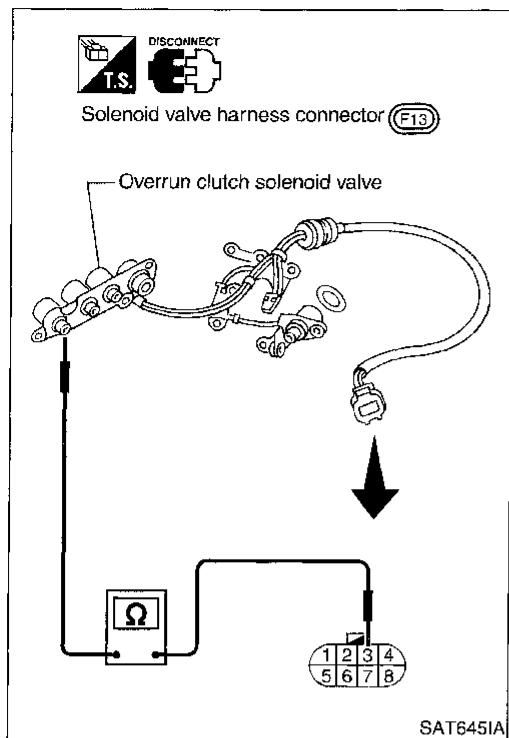

Operation check

- Check solenoid valve by listening for its operating sound while applying battery voltage to the terminal and ground.

GI
MA
EM
LC
EC
FE
CL
MT
AT
FA
RA
BR
ST
RS
BT
HA
EL
IDX

TROUBLE DIAGNOSIS FOR BATT/FLUID TEMP SEN

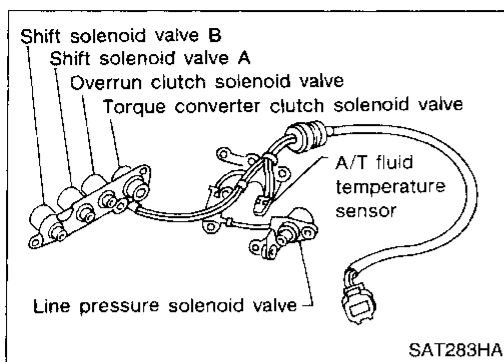

A/T Fluid Temperature Sensor Circuit and TCM Power Source

DESCRIPTION

The A/T fluid temperature sensor detects the A/T fluid temperature and sends a signal to the TCM.

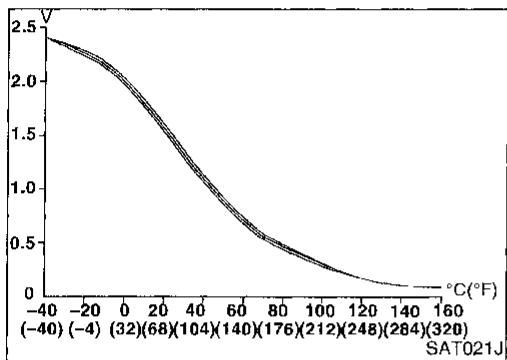

CONSULT REFERENCE VALUE IN DATA MONITOR MODE

Remarks: Specification data are reference values.

Monitor item	Condition	Specification
A/T fluid temperature sensor	Cold [20°C (68°F)]	Approximately 1.5V
	↓	↓
	Hot [80°C (176°F)]	Approximately 0.5V

TCM TERMINALS AND REFERENCE VALUE



Remarks: Specification data are reference values.

Terminal No.	Wire color	Item	Condition	Judgement standard
4	SB	Power source	When turning ignition switch to "ON".	Battery voltage
			When turning ignition switch to "OFF".	1V or less
9	SB	Power source	Same as No. 4	
23	R/B	Power source (Memory back-up)	or When turning ignition switch to "OFF".	Battery voltage
			When turning ignition switch to "ON".	Battery voltage
33	BR	A/T fluid temperature sensor	When ATF temperature is 20°C (68°F).	Approximately 1.5V
			When ATF temperature is 80°C (176°F).	Approximately 0.5V
35	B	Throttle position sensor (Ground)		—

TROUBLE DIAGNOSIS FOR BATT/FLUID TEMP SEN

A/T Fluid Temperature Sensor Circuit and TCM Power Source (Cont'd)

ON BOARD DIAGNOSIS LOGIC

Diagnostic trouble code	Malfunction is detected when ...	Check item (Possible cause)
 : BATT/FLUID TEMP SEN  : 8th judgement flicker	TCM receives an excessively low or high voltage from the sensor.	<ul style="list-style-type: none"> ● Harness or connectors (The sensor circuit is open or shorted.) ● A/T fluid temperature sensor

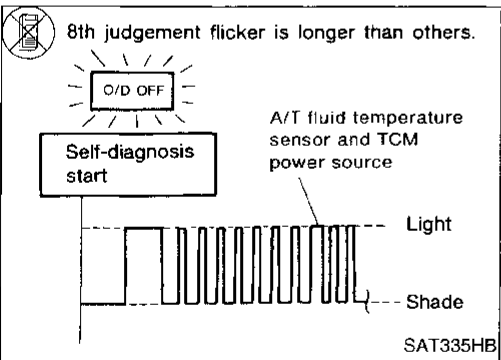
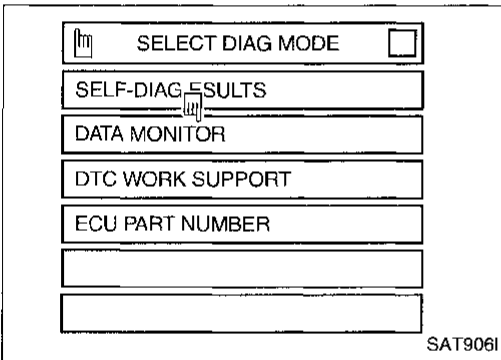
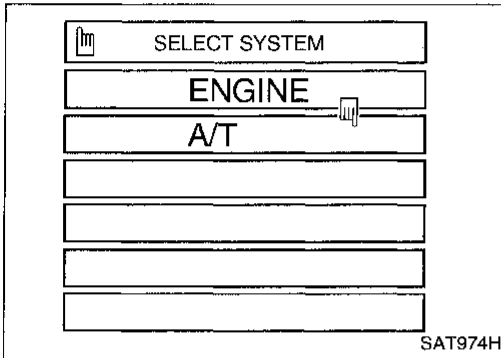

DIAGNOSTIC TROUBLE CODE (DTC) CONFIRMATION PROCEDURE

After the repair, perform the following procedure to confirm the malfunction is eliminated.

- 1) Start engine.
- 2) Select "DATA MONITOR" mode for "A/T" with CONSULT.
- 3) Drive vehicle under the following conditions:
Selector lever in "D", vehicle speed higher than 20 km/h (12 MPH).

OR

- 1) Start engine.
- 2) Drive vehicle under the following conditions:
Selector lever in "D", vehicle speed higher than 20 km/h (12 MPH).
- 3) Perform self-diagnosis.
Refer to TCM SELF-DIAGNOSTIC PROCEDURE (No Tools), AT-43.

TROUBLE DIAGNOSIS FOR BATT/FLUID TEMP SEN

A/T Fluid Temperature Sensor Circuit and TCM Power Source (Cont'd)

WIRING DIAGRAM — AT — BA/FTS

AT-BA/FTS-01

— : Detectable line for DTC

— : Non-detectable line for DTC

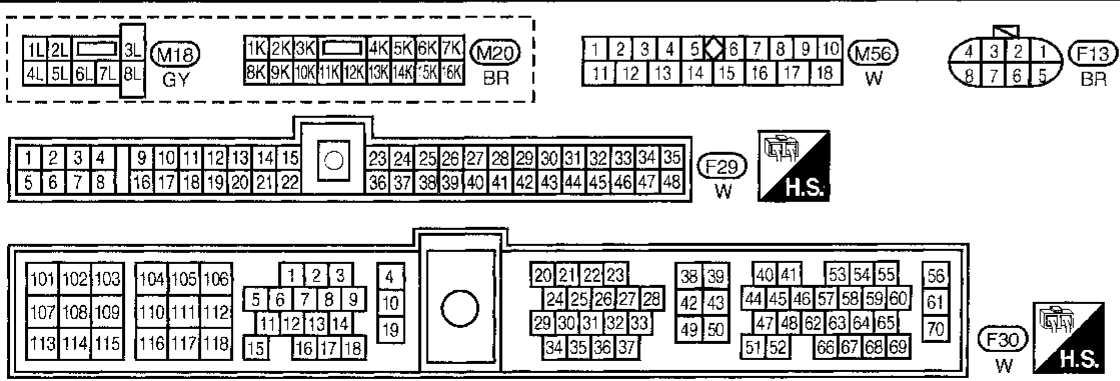
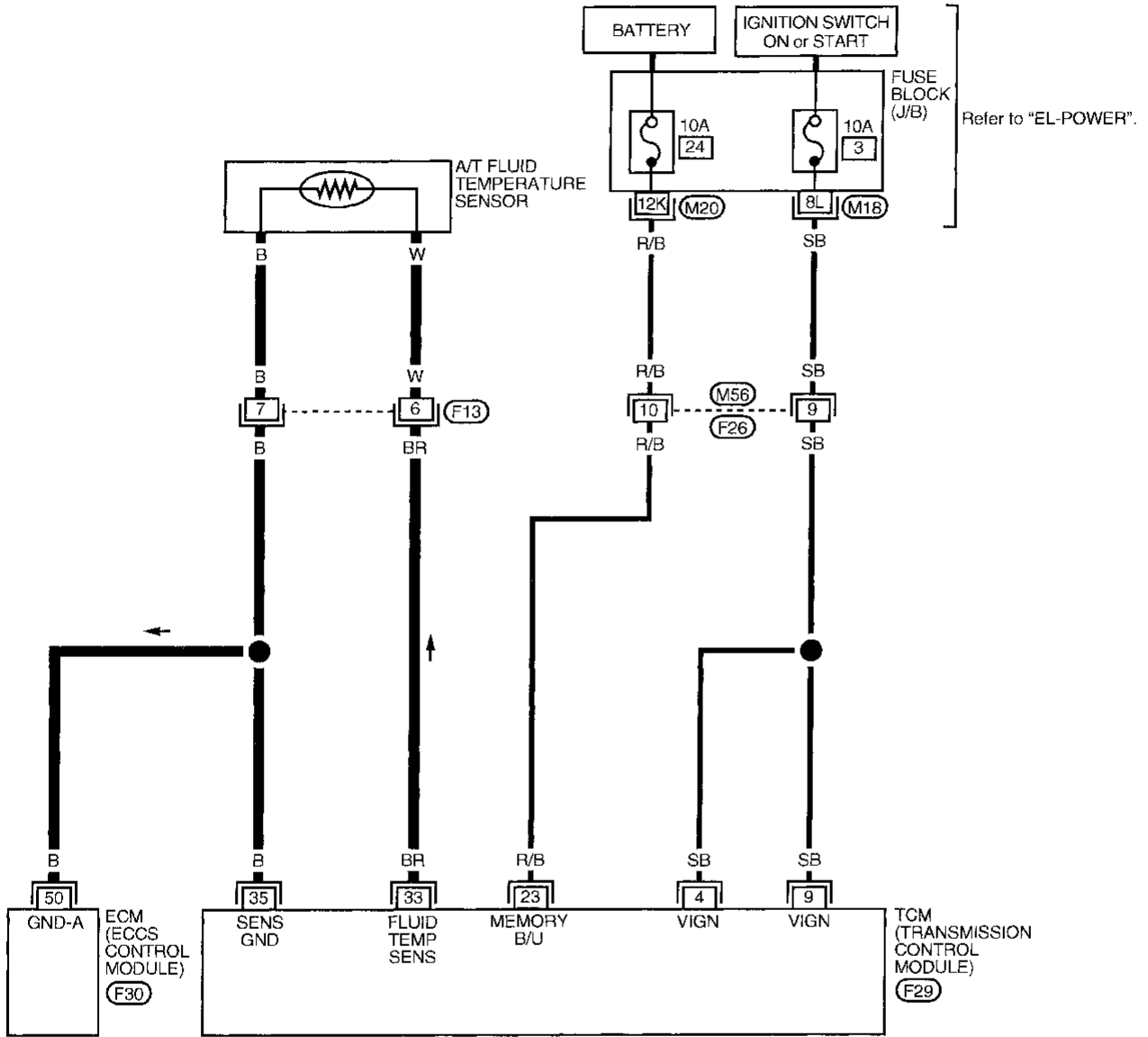

TROUBLE DIAGNOSIS FOR BATT/FLUID TEMP SEN

A/T Fluid Temperature Sensor Circuit and TCM Power Source (Cont'd)

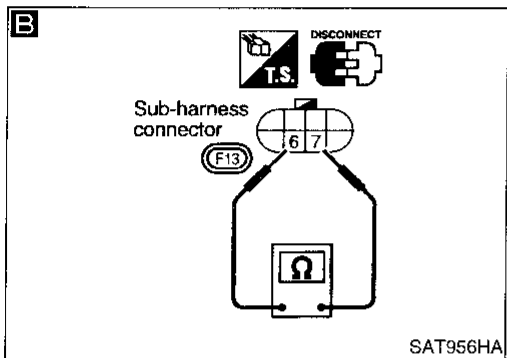
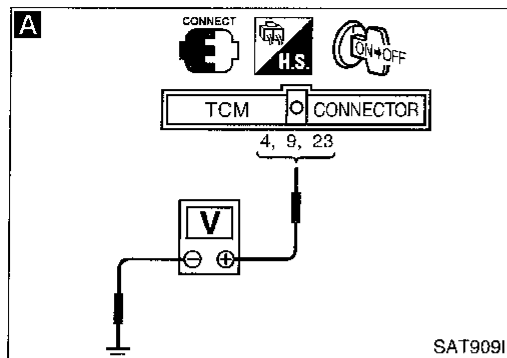

DIAGNOSTIC PROCEDURE

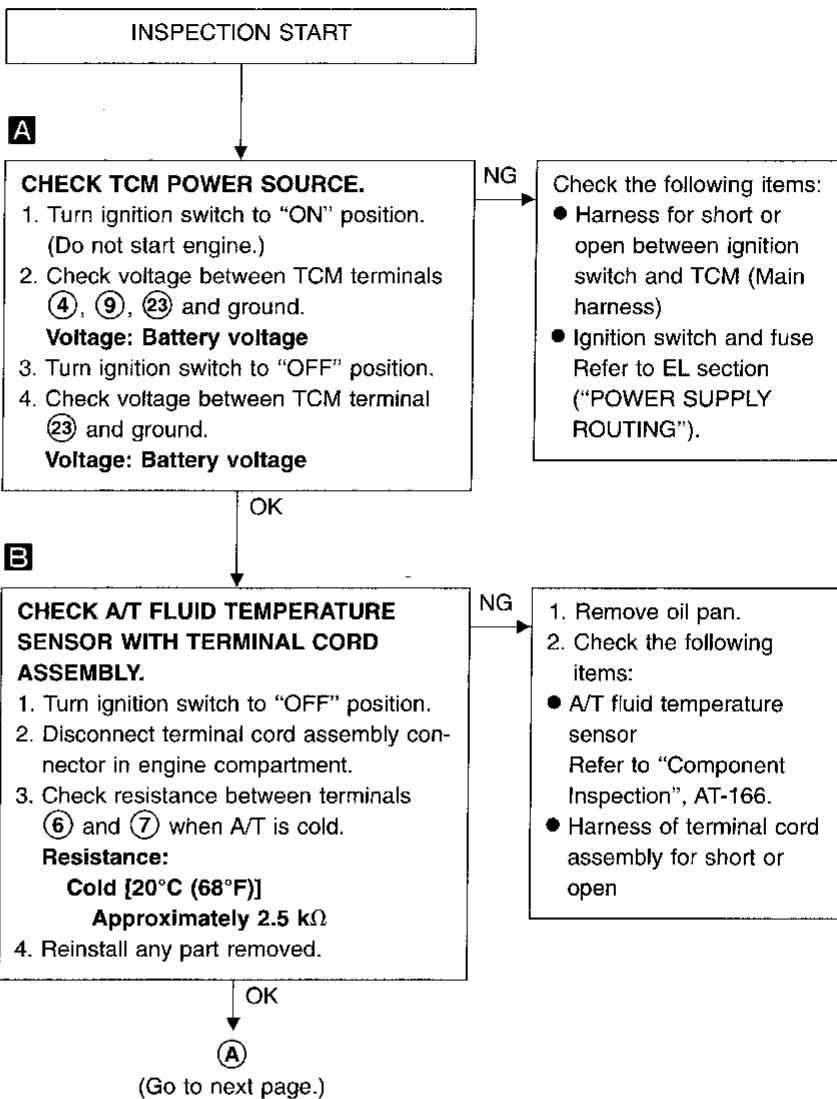

GI
WA
EM
LC
EC
FE
CL
MT
AT
FA
RA
BR
ST
RS
BT
HA
EL
IDX

TROUBLE DIAGNOSIS FOR BATT/FLUID TEMP SEN

A/T Fluid Temperature Sensor Circuit and TCM Power Source (Cont'd)

C

☆ MONITOR	☆ NO FAIL	
VHCL/S SE-A/T	0km/h	
VHCL/S SE-MTR	5km/h	
THRTL POS SEN	0.4V	
FLUID TEMP SE	1.2V	
BATTERY VOLT	13.4V	
ENGINE SPEED	1024rpm	
OVERDRIVE SW	0 N	
P/N POSI SW	0 N	
R POSITION SW	OFF	

RECORD

SAT076H

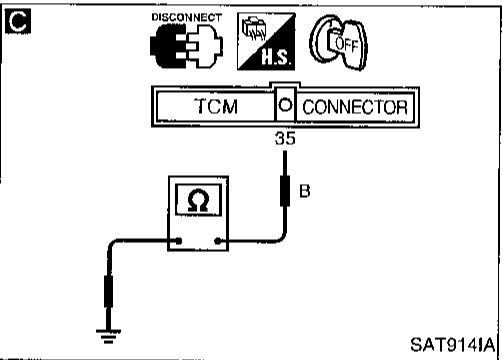
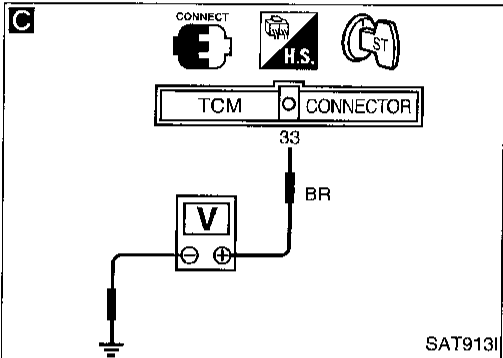

C

CHECK INPUT SIGNAL OF A/T FLUID TEMPERATURE SENSOR.

1. Start engine.
2. Select "ECU INPUT SIGNALS" in "DATA MONITOR" mode for "A/T" with CONSULT.
3. Read out the value of "FLUID TEMP SE".

Voltage:
 Cold [20°C (68°F)] →
 Hot [80°C (176°F)]:
 Approximately
 1.5V → 0.5V

OR

1. Start engine.
2. Check voltage between TCM terminal (33) and ground while warming up A/T.

Voltage:
 Cold [20°C (68°F)] →
 Hot [80°C (176°F)]:
 Approximately
 1.5V → 0.5V

3. Turn ignition switch to "OFF" position.
4. Disconnect TCM harness connector.
5. Check resistance between terminal (35) and ground.

Continuity should exist.

NG →

Check the following item:

- Harness for short or open between TCM, ECM and terminal cord assembly (Main harness)
- Ground circuit for ECM Refer to EC section ("TROUBLE DIAGNOSIS FOR POWER SUPPLY").

OK

Perform Diagnostic Trouble Code (DTC) confirmation procedure, AT-163.

OK

INSPECTION END

NG →

1. Perform TCM input/output signal inspection.
2. If NG, recheck TCM pin terminals for damage or loose connection with harness connector.

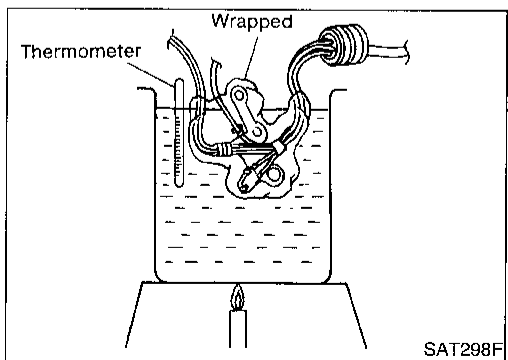

COMPONENT INSPECTION

A/T fluid temperature sensor

- For removal, refer to AT-204.
- Check resistance between two terminals while changing temperature as shown at left.

Temperature °C (°F)	Resistance
20 (68)	Approximately 2.5 kΩ
80 (176)	Approximately 0.3 kΩ

TROUBLE DIAGNOSIS FOR VHCL SPEED SEN-MTR

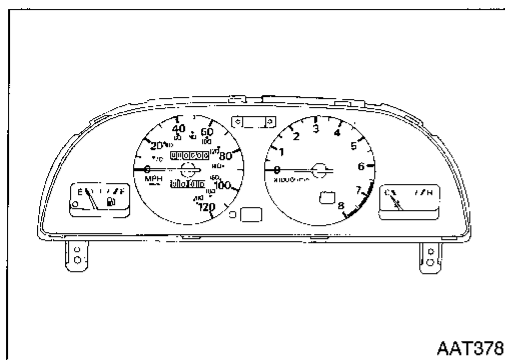

Vehicle Speed Sensor-MTR

DESCRIPTION

The vehicle speed sensor-MTR is built into the speedometer assembly. The sensor functions as an auxiliary device to the revolution sensor when it is malfunctioning. The TCM will then use a signal sent from the vehicle speed sensor-MTR.

GI
MA

EM

LC

TCM TERMINALS AND REFERENCE VALUE

Remarks: Specification data are reference values.



Terminal No.	Wire color	Item	Condition	Judgement standard
27	PU/R	Vehicle speed sensor	 When moving vehicle at 2 to 3 km/h (1 to 2 MPH) for 1 m (3 ft) or more.	Voltage varies between less than 1V and more than 4.5V

EC

FE

CL

ON BOARD DIAGNOSIS LOGIC

Diagnostic trouble code	Malfunction is detected when ...	Check item (Possible cause)
 : VHCL SPEED SEN-MTR	TCM does not receive the proper voltage signal from the sensor.	<ul style="list-style-type: none"> ● Harness or connectors (The sensor circuit is open or shorted.) ● Vehicle speed sensor
 : 2nd judgement flicker		

MT

AT

FA

RA

BR

ST

RS

BT

HA

EL

IDX

TROUBLE DIAGNOSIS FOR VHCL SPEED SEN-MTR

Vehicle Speed Sensor-MTR (Cont'd)

DIAGNOSTIC TROUBLE CODE (DTC) CONFIRMATION PROCEDURE

CAUTION:

- Always drive vehicle at a safe speed.
- If conducting this "DTC CONFIRMATION PROCEDURE" again, always turn ignition switch "OFF" and wait at least 5 seconds before continuing.

After the repair, perform the following procedure to confirm the malfunction is eliminated.



- 1) Turn ignition switch "ON" and select "DATA MONITOR" mode for "A/T" with CONSULT.
- 2) Start engine and accelerate vehicle from 0 to 25 km/h (0 to 16 MPH).

OR



- 1) Start engine.
- 2) Drive vehicle under the following conditions:
Selector lever in "D" and vehicle speed higher than 25 km/h (16 MPH).
- 3) Perform self-diagnosis.
Refer to TCM SELF-DIAGNOSTIC PROCEDURE (No Tools), AT-43.

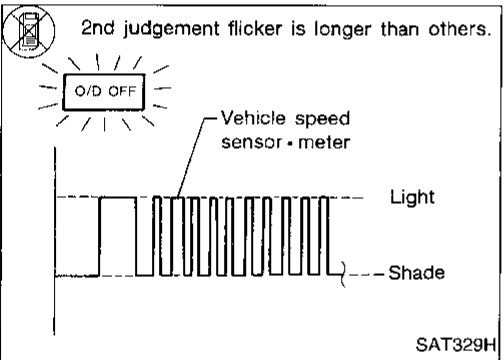
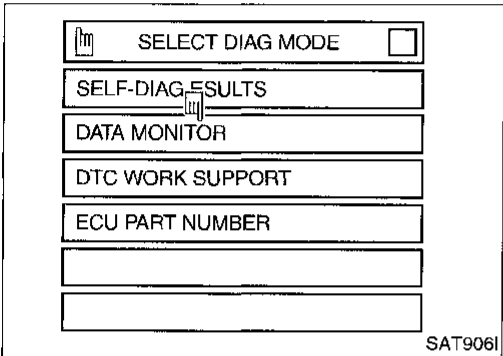
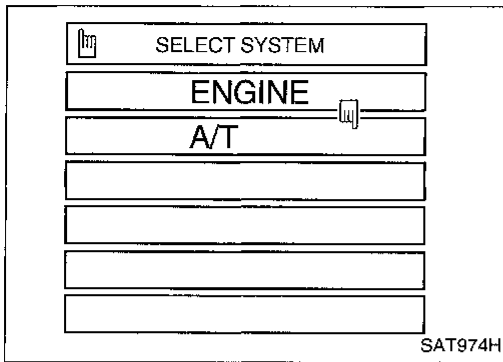

TROUBLE DIAGNOSIS FOR VHCL SPEED SEN·MTR

Vehicle Speed Sensor·MTR (Cont'd)

WIRING DIAGRAM — AT — VSSMTR

AT-VSSMTR-01

GI

MA

EM

LC

EC

FE

CL

MT

AT

FA

RA

BR

ST

RS

BT

HA

EL

IDX

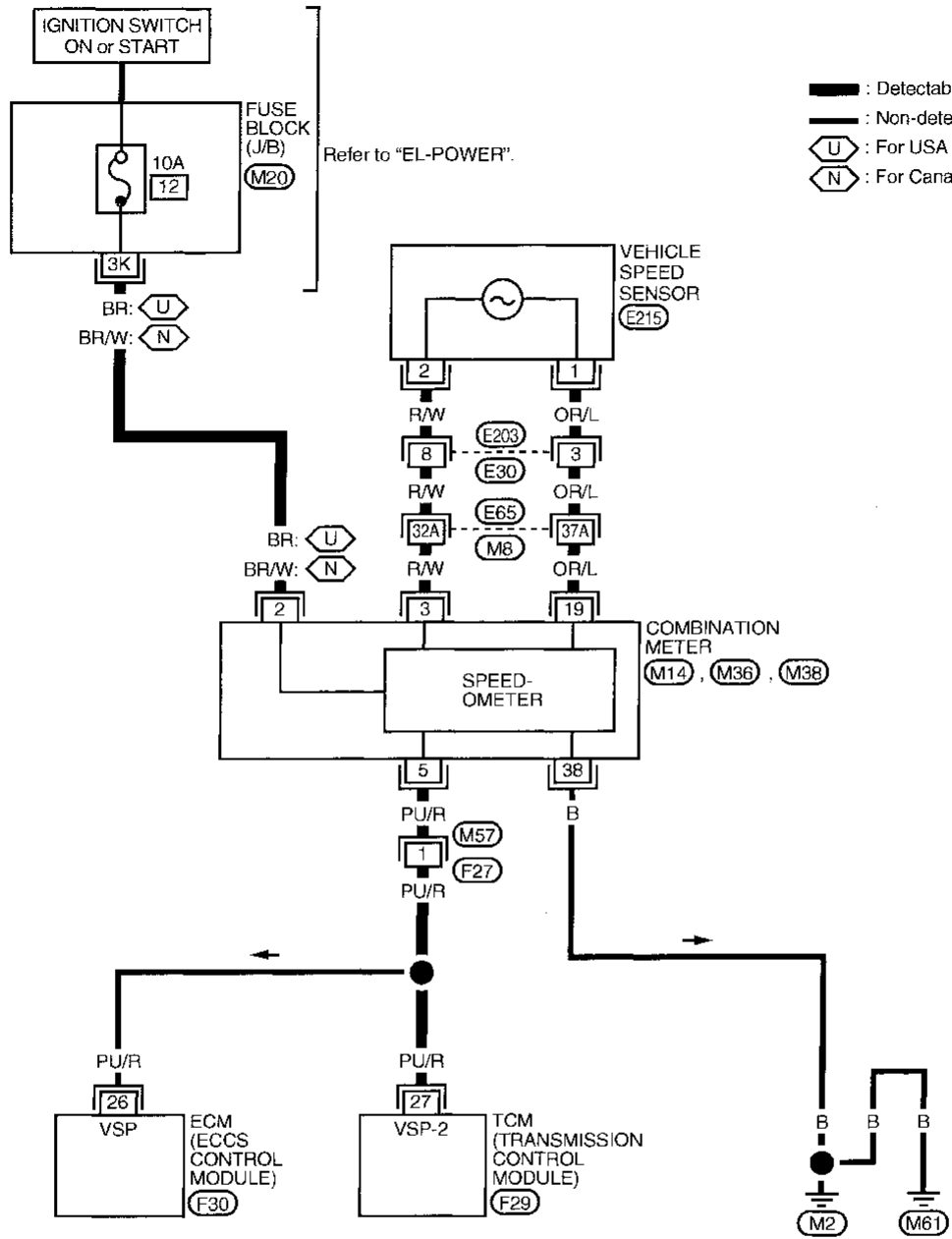

— : Detectable line for DTC
 — : Non-detectable line for DTC
 U : For USA
 N : For Canada

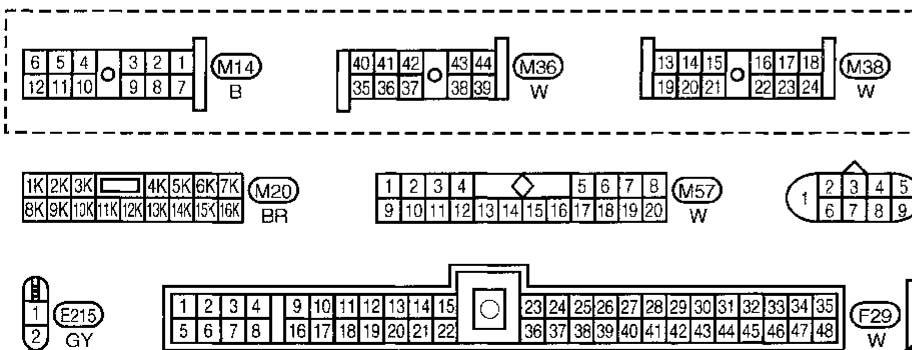

Refer to last page (Foldout page).

(M8), (E65)
(F30)

TROUBLE DIAGNOSIS FOR VHCL SPEED SEN·MTR

Vehicle Speed Sensor·MTR (Cont'd) DIAGNOSTIC PROCEDURE

A

☆MONITOR	☆NO FAIL	
VHCL/S SE·A/T	0km/h	
VHCL/S SE·MTR	5km/h	
THRTL POS SEN	0.4V	
FLUID TEMP SE	1.2V	
BATTERY VOLT	13.4V	
ENGINE SPEED	1024rpm	
OVERDRIVE SW	O N	
P/N POSI SW	O N	
R POSITION SW	OFF	

RECORD

SAT076H

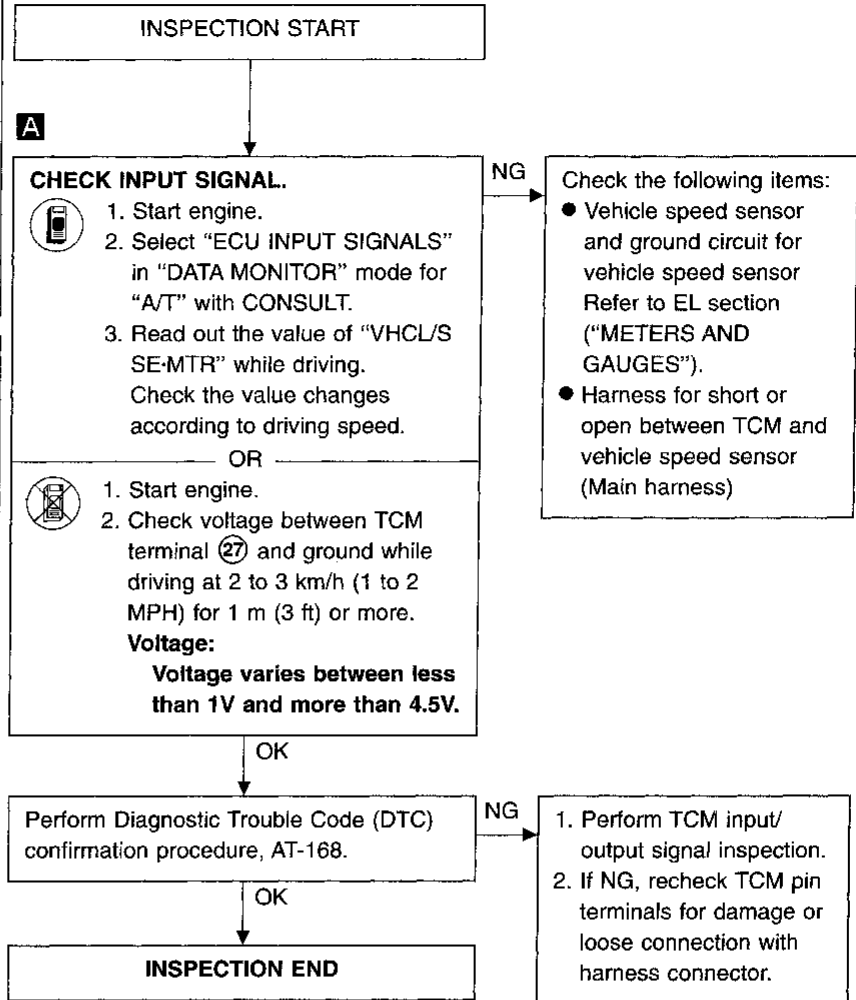
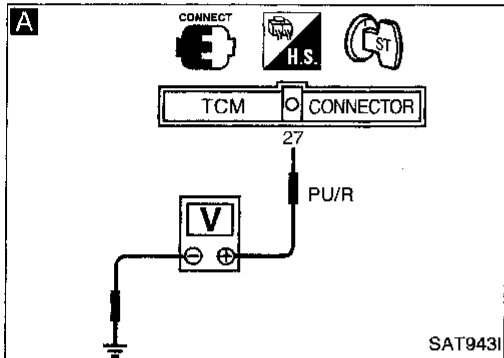

TROUBLE DIAGNOSES FOR SYMPTOMS

Non-detectable Items

WIRING DIAGRAM — AT — NON-DTC

AT-NONDTC-01

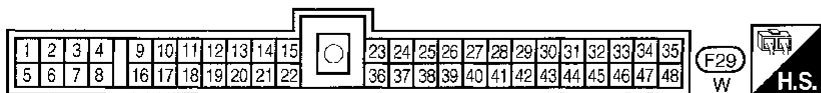
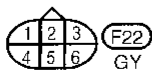
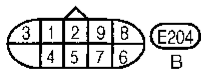
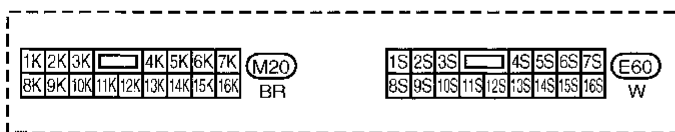
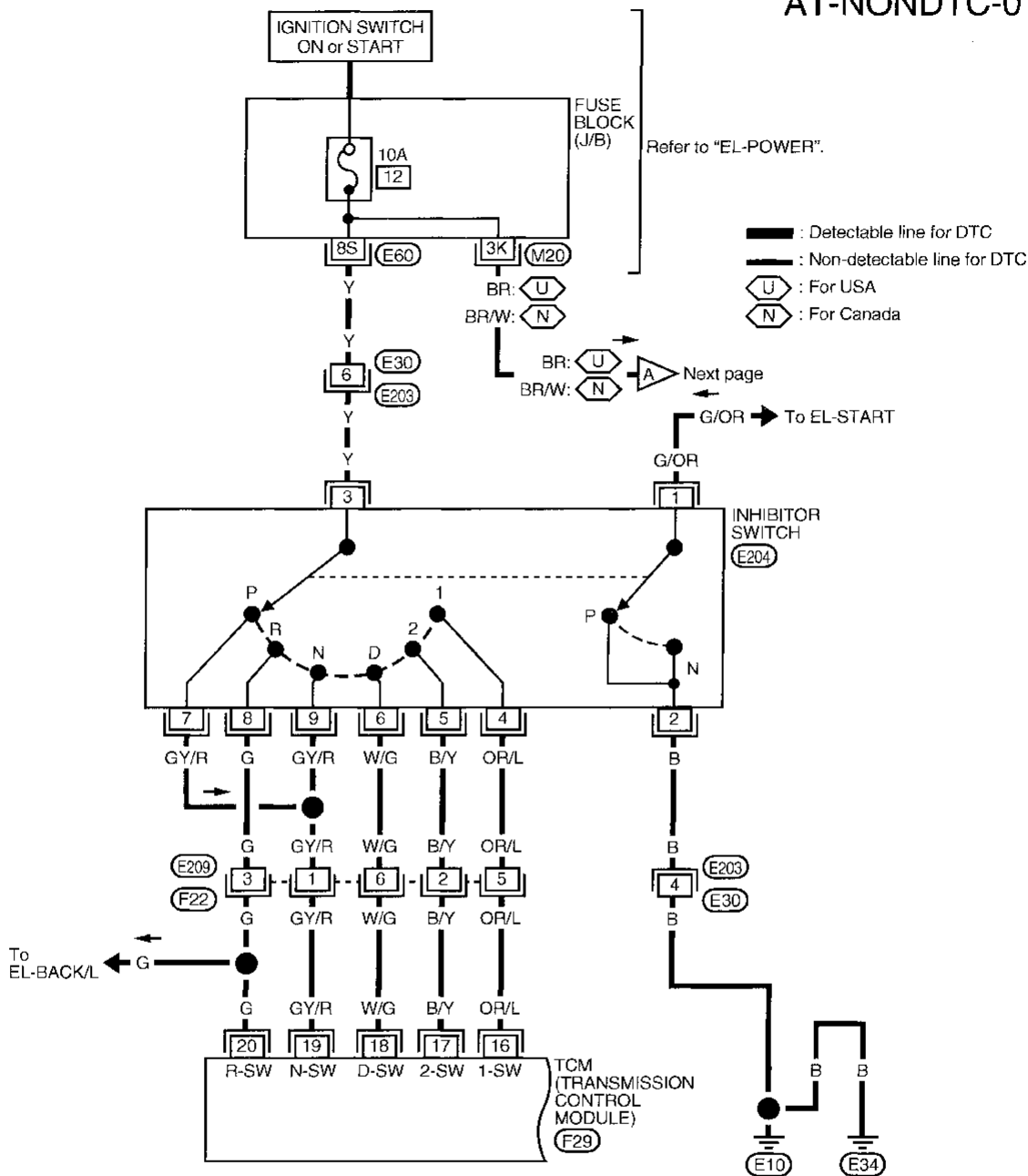

GI
 MA
 EM
 LC
 EC
 FE
 CL
 MT
AT
 FA
 RA
 BR
 ST
 RS
 BT
 HA
 EL
 IDX

TROUBLE DIAGNOSES FOR SYMPTOMS

Non-detectable Items (Cont'd)

AT-NONDTC-02

- : Detectable line for DTC
- : Non-detectable line for DTC
- U : For USA
- N : For Canada

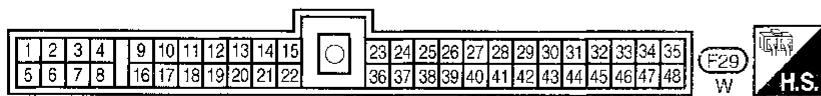
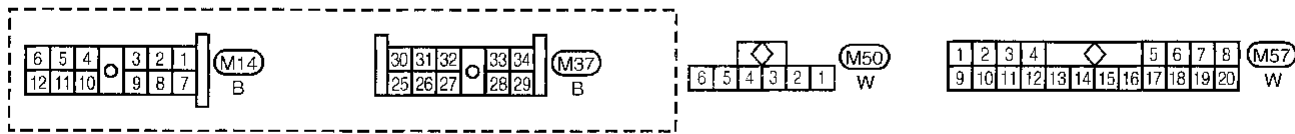
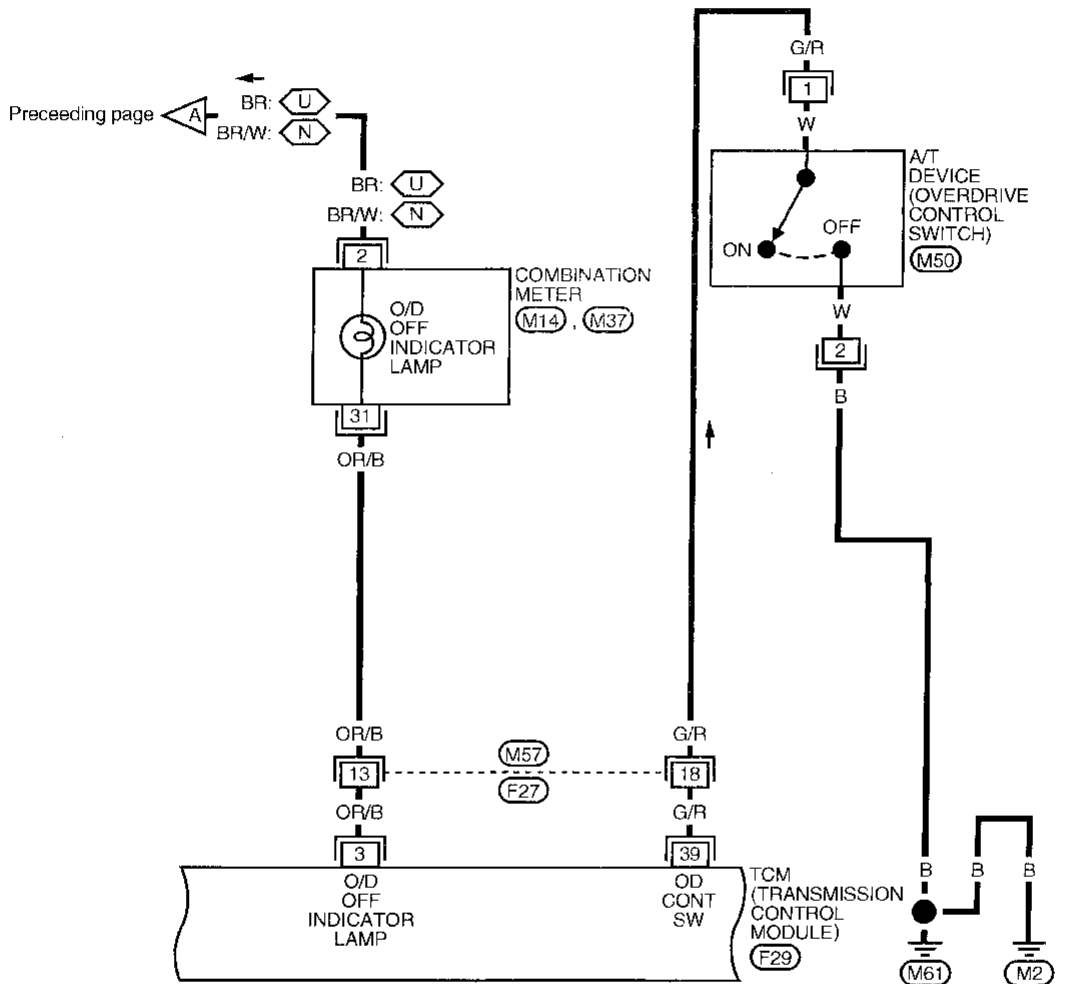

TROUBLE DIAGNOSES FOR SYMPTOMS

Non-detectable Items (Cont'd)

AT-NONDTC-03

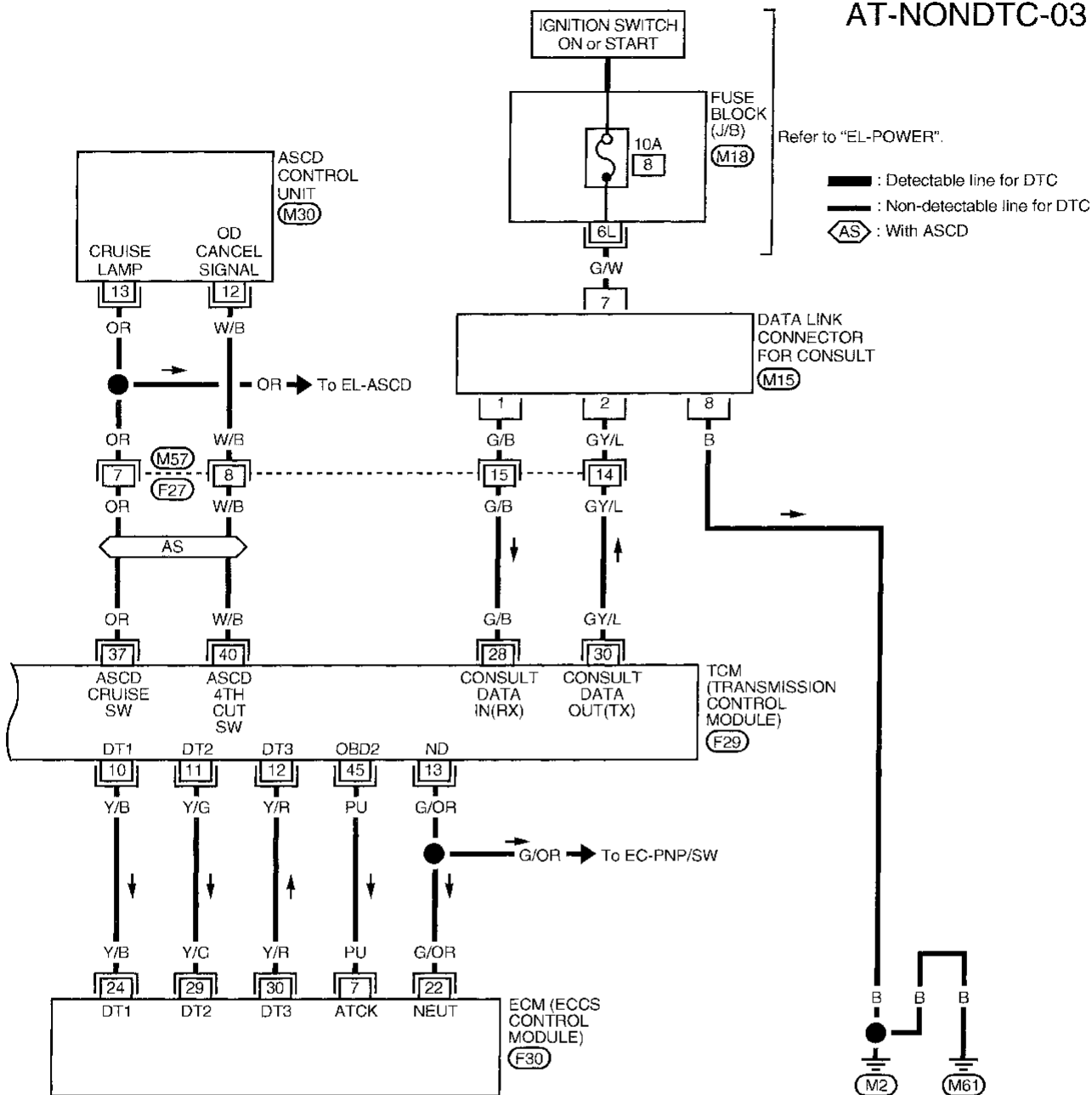

CI
MA
EM
LC
EC
FE
CL
MT
AT
FA
RA
BR
ST
RS

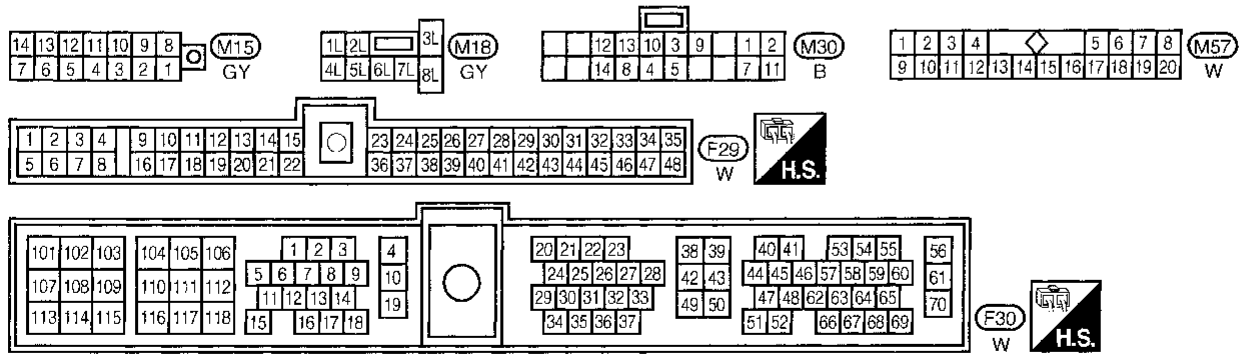

BT
HA
EL
IDX

1. O/D OFF Indicator Lamp Does Not Come On

SYMPTOM:

O/D OFF indicator lamp does not come on for about 2 seconds when turning ignition switch to "ON".

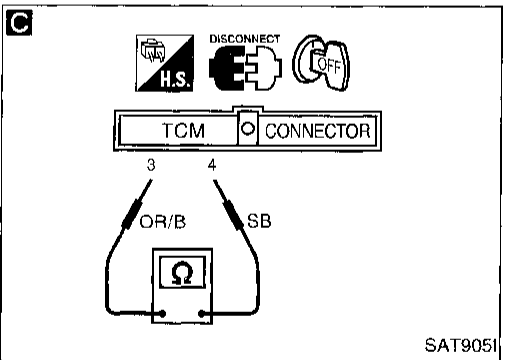
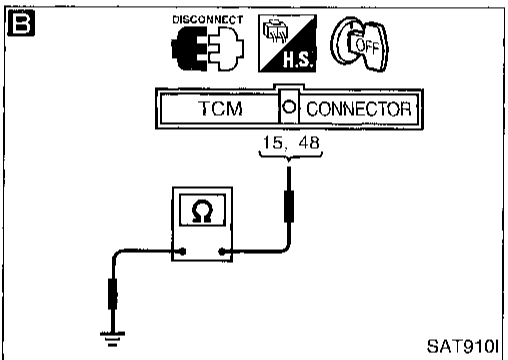
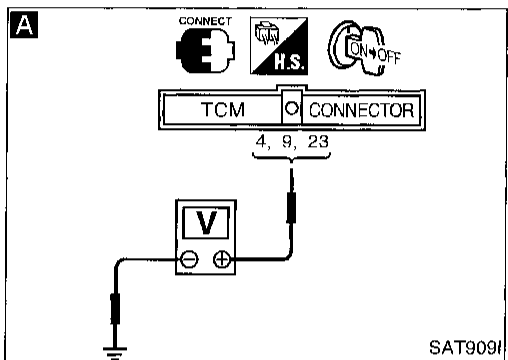
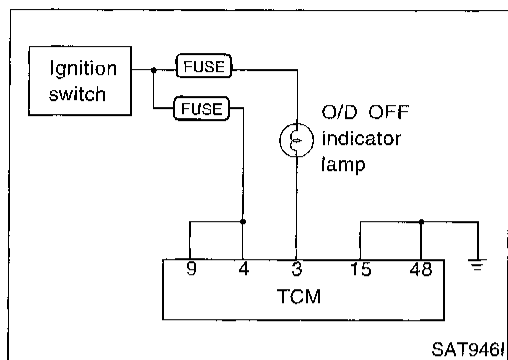

A

CHECK TCM POWER SOURCE.

1. Turn ignition switch to "ON" position. (Do not start engine.)
2. Check voltage between TCM terminals (4), (9), (23) and ground.
Voltage: Battery voltage
3. Turn ignition switch to "OFF" position.
4. Check voltage between TCM terminal (23) and ground.
Voltage: Battery voltage

NG

Check the following items:

- Harness for short or open between ignition switch and TCM (Main harness)
Refer to "Wiring Diagram — AT — MAIN" in AT-74.
- Ignition switch and fuse
Refer to EL section ("POWER SUPPLY ROUTING").

B

CHECK TCM GROUND CIRCUIT.

1. Turn ignition switch to "OFF" position.
2. Disconnect TCM harness connector.
3. Check continuity between TCM terminals (15), (48) and ground.
Continuity should exist.
If OK, check harness for short to ground and short to power.

NG

Repair open circuit or short to ground or short to power in harness or connectors.
Refer to "Wiring Diagram — AT — MAIN" in AT-74.

C

CHECK LAMP CIRCUIT.

1. Turn ignition switch to "OFF" position.
2. Check resistance between TCM terminals (3) and (4).
Resistance: 50 - 100Ω
3. Reinstall any part removed.

NG

Check the following items:

- O/D OFF indicator lamp
Refer to EL section.
- Harness and fuse for short or open between ignition switch and O/D OFF indicator lamp (Main harness)
Refer to EL section ("POWER SUPPLY ROUTING").
- Harness for short or open between O/D OFF indicator lamp and TCM

Check again.

NG

1. Perform TCM input/output signal inspection.
2. If NG, recheck TCM pin terminals for damage or loose connection with harness connector.

INSPECTION END

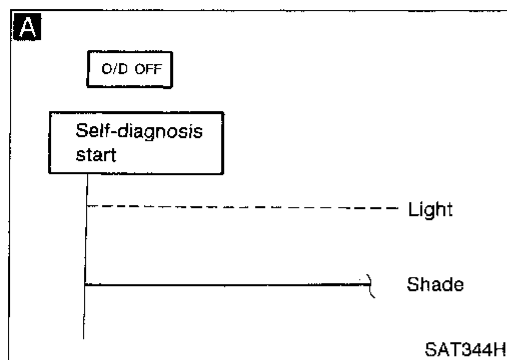

2. Engine Cannot Be Started In "P" and "N" Position

SYMPTOM:

- Engine cannot be started with selector lever in "P" or "N" position.
- Engine can be started with selector lever in "D", "2", "1" or "R" position.

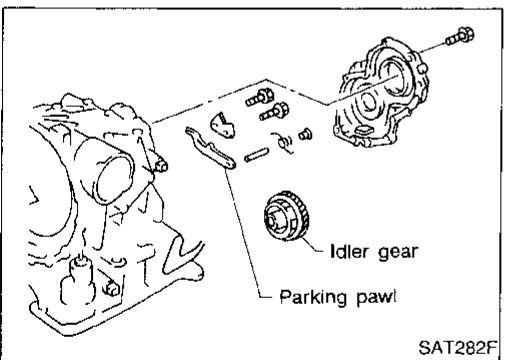
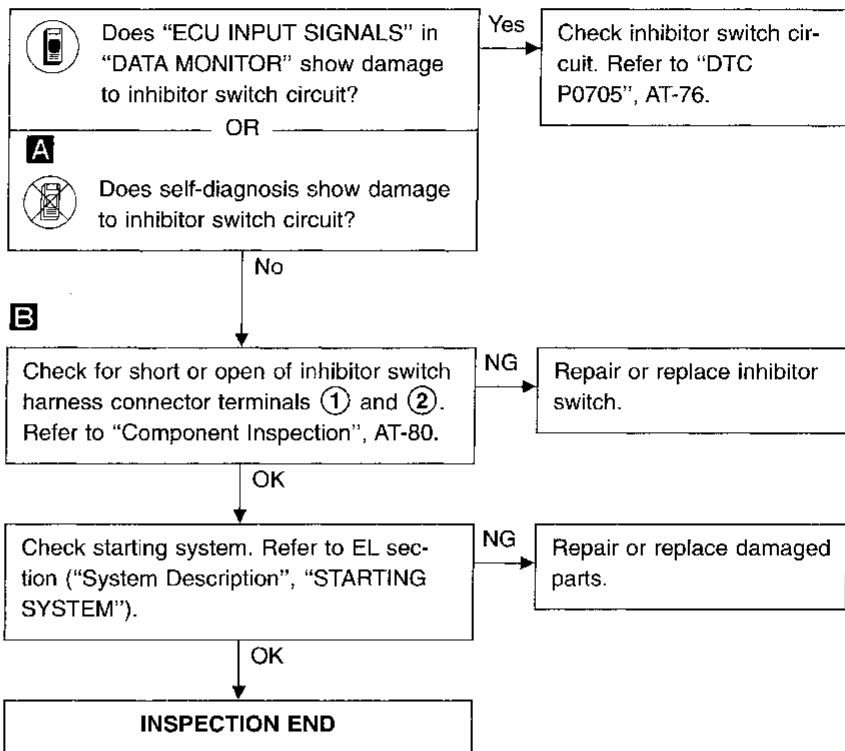
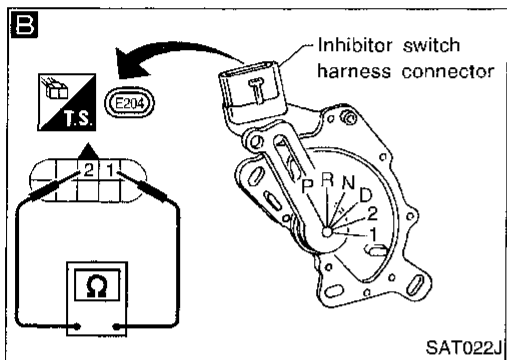

3. In "P" Position, Vehicle Moves Forward or Backward When Pushed

SYMPTOM:

Vehicle moves when it is pushed forward or backward with selector lever in "P" position.

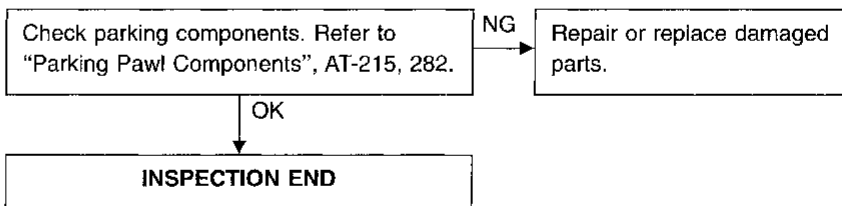

4. In "N" Position, Vehicle Moves

SYMPTOM:

Vehicle moves forward or backward when selecting "N" position.

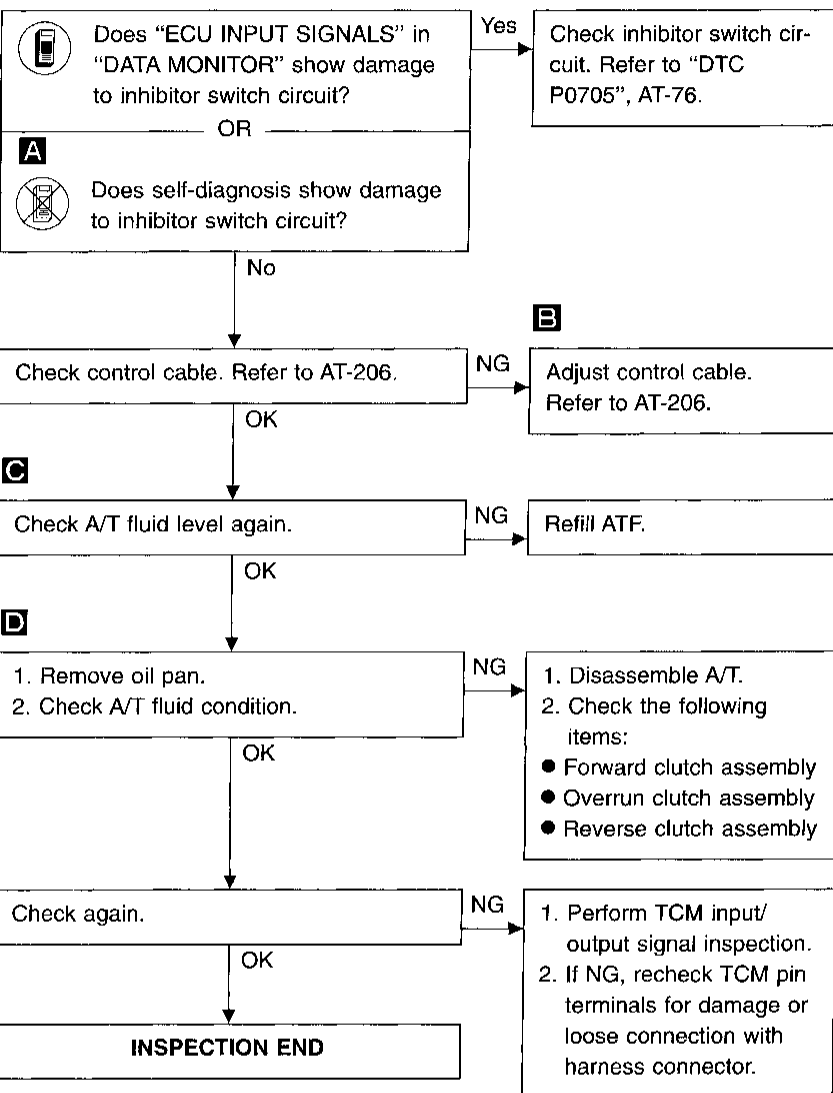
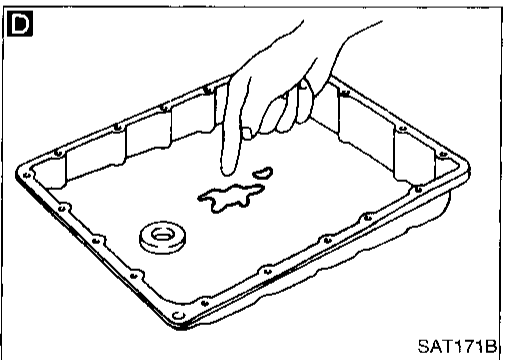
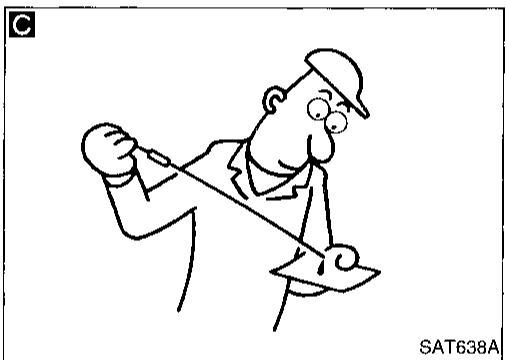
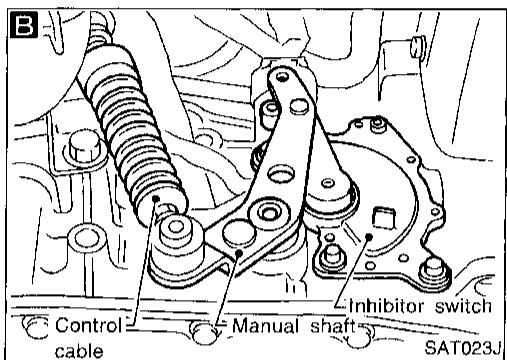
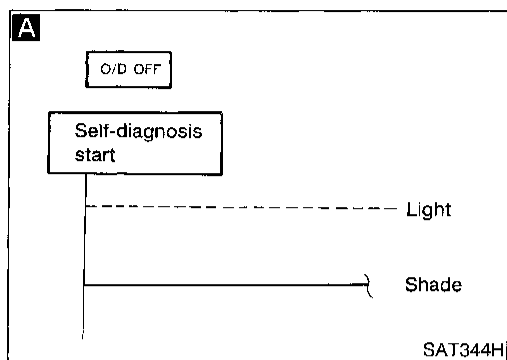

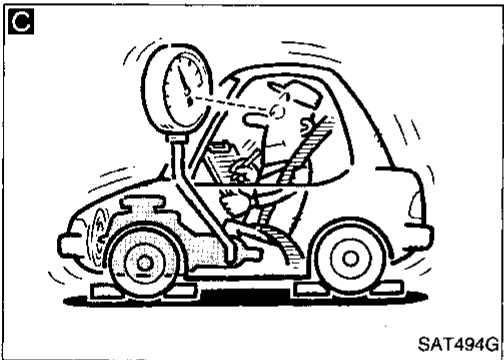
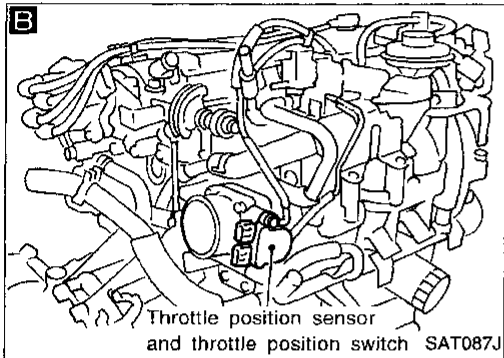
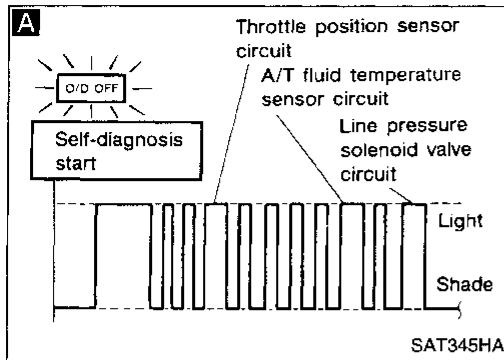

5. Large Shock. "N" → "R" Position

SYMPTOM:

There is large shock when changing from "N" to "R" position.

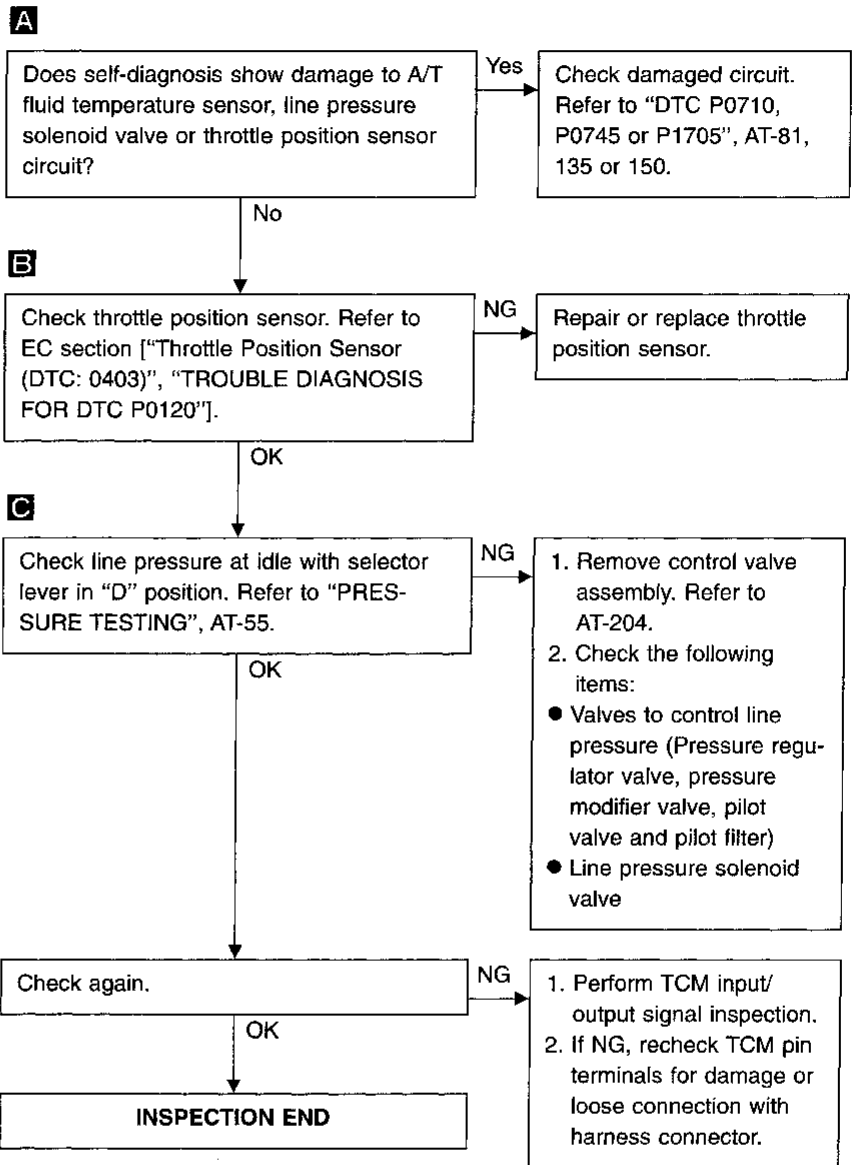

CI

MA

EM

LC

EC

FE

CL

MT

AT

FA

RA

BR

ST

RS

BT

HA

EL

IDX

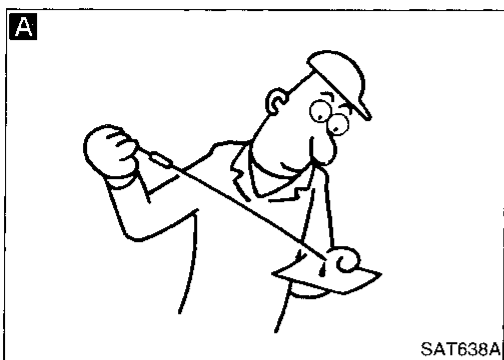

6. Vehicle Does Not Creep Backward In "R" Position

SYMPTOM:

Vehicle does not creep backward when selecting "R" position.

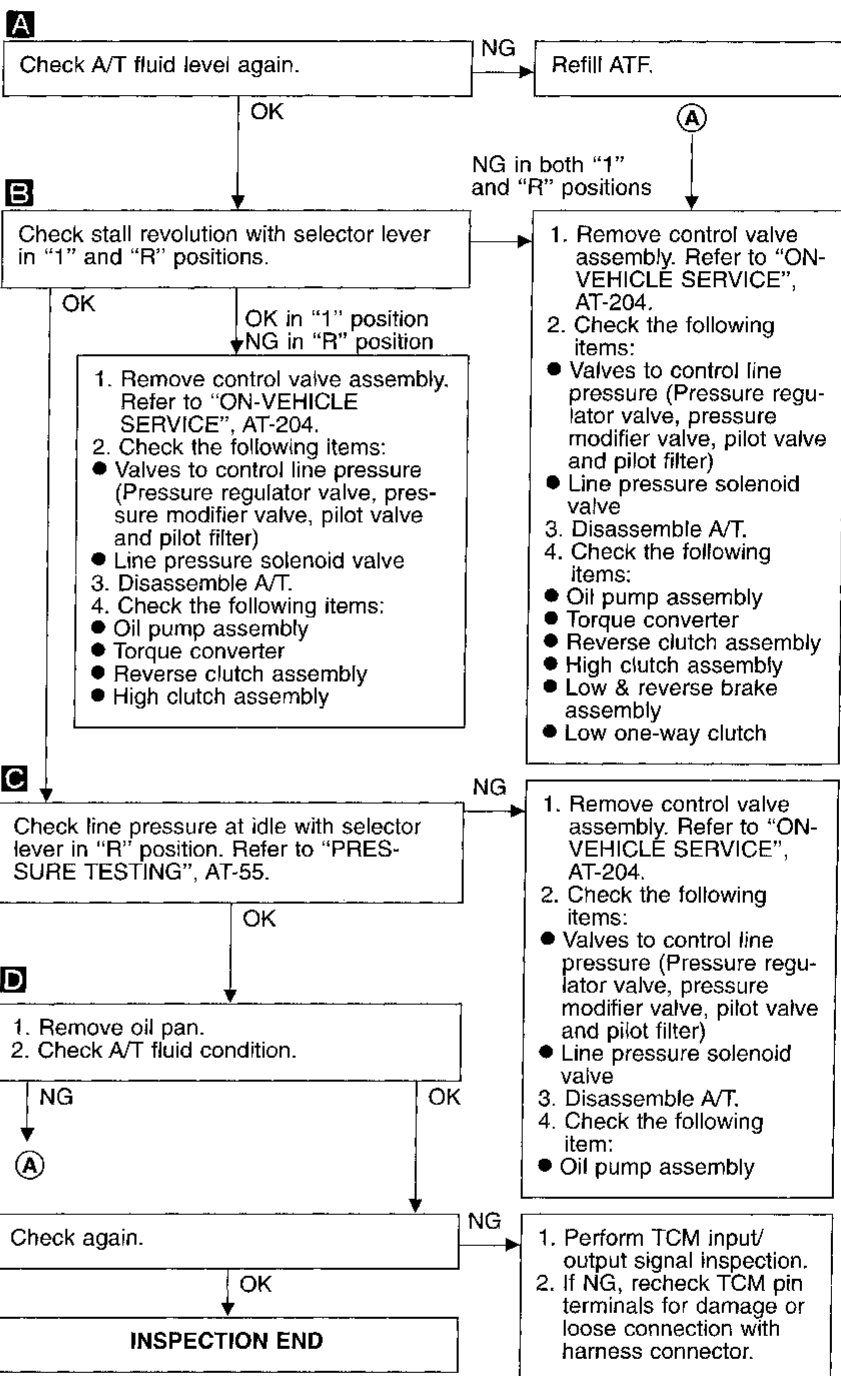
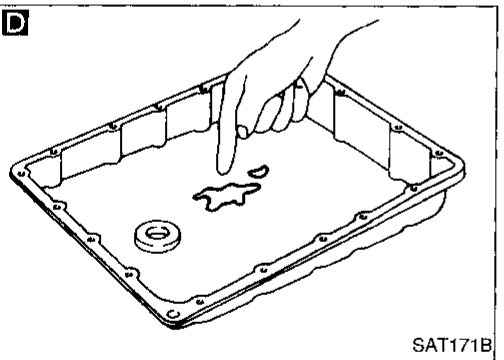
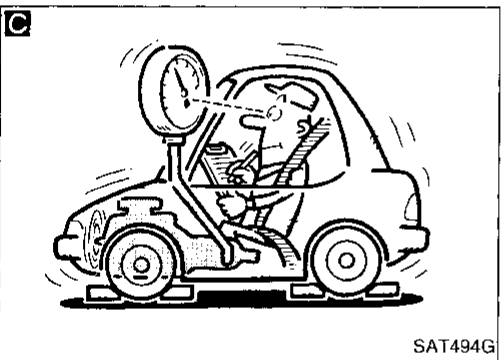
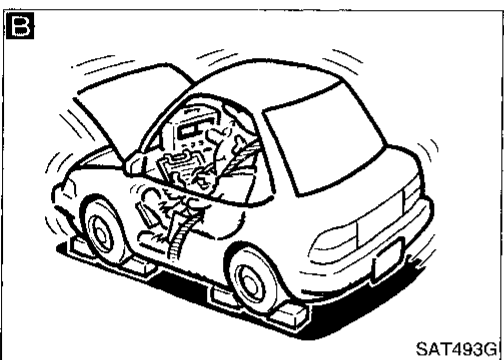

TROUBLE DIAGNOSES FOR SYMPTOMS

GI
MA
EM
LC
EC
FE
CL
MT
AT
FA
RA
BR
ST
RS
BT
HA
EL
IDX

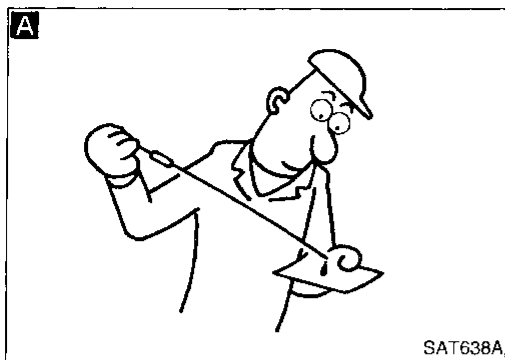

7. Vehicle Does Not Creep Forward In "D", "2" or "1" Position

SYMPTOM:

Vehicle does not creep forward when selecting "D", "2" or "1" position.

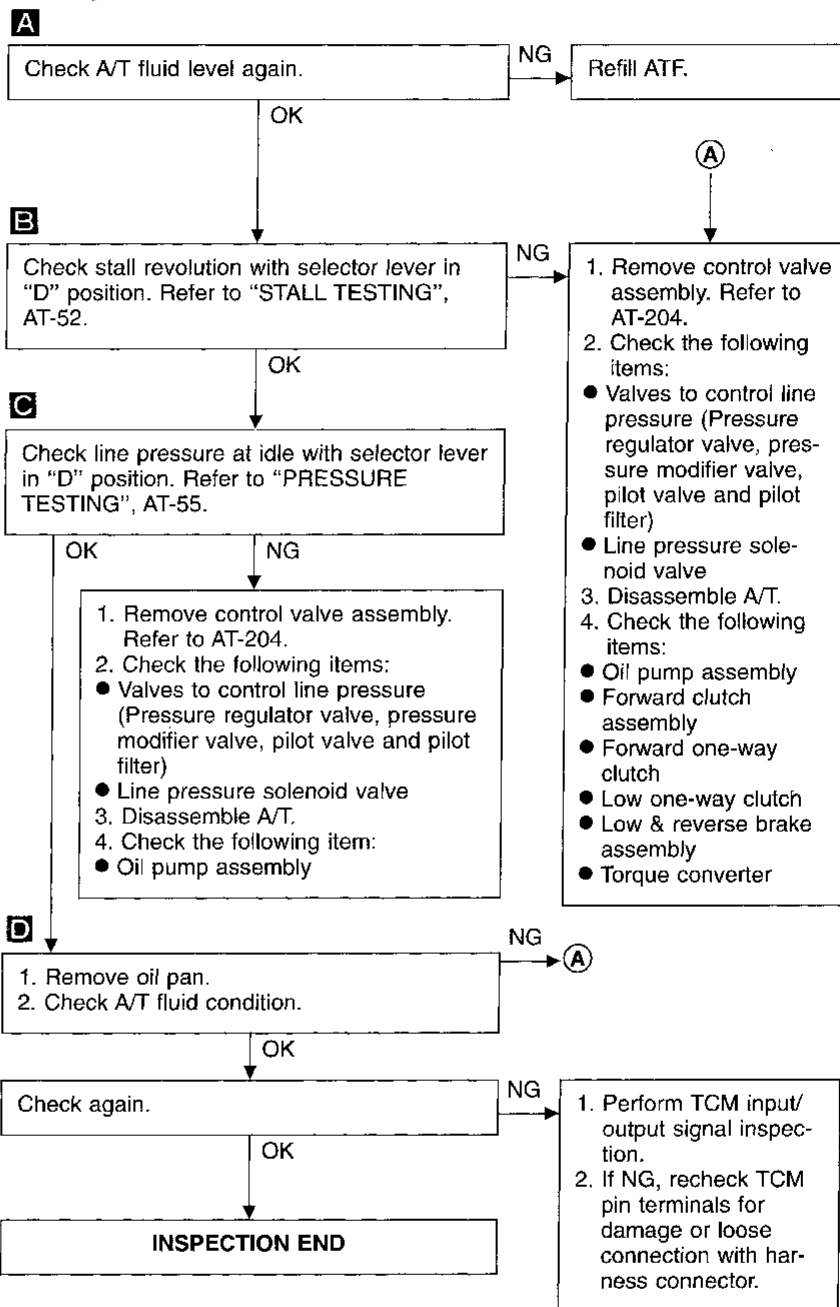
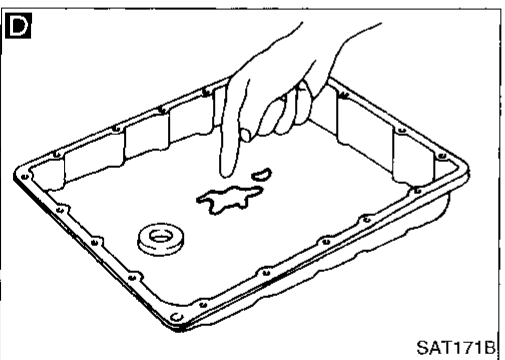
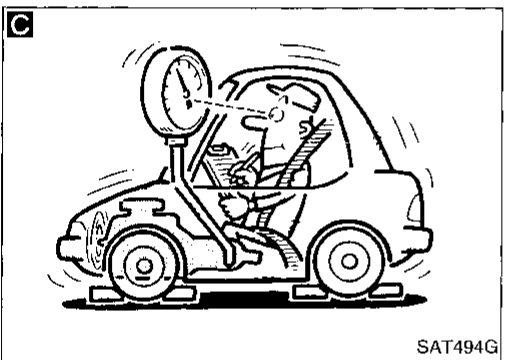
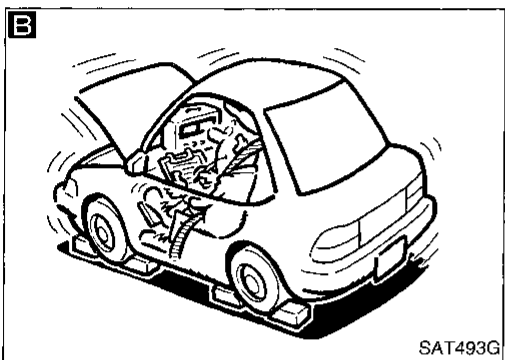

8. Vehicle Cannot Be Started From D₁

SYMPTOM:

Vehicle cannot be started from D₁ on Cruise test — Part 1.

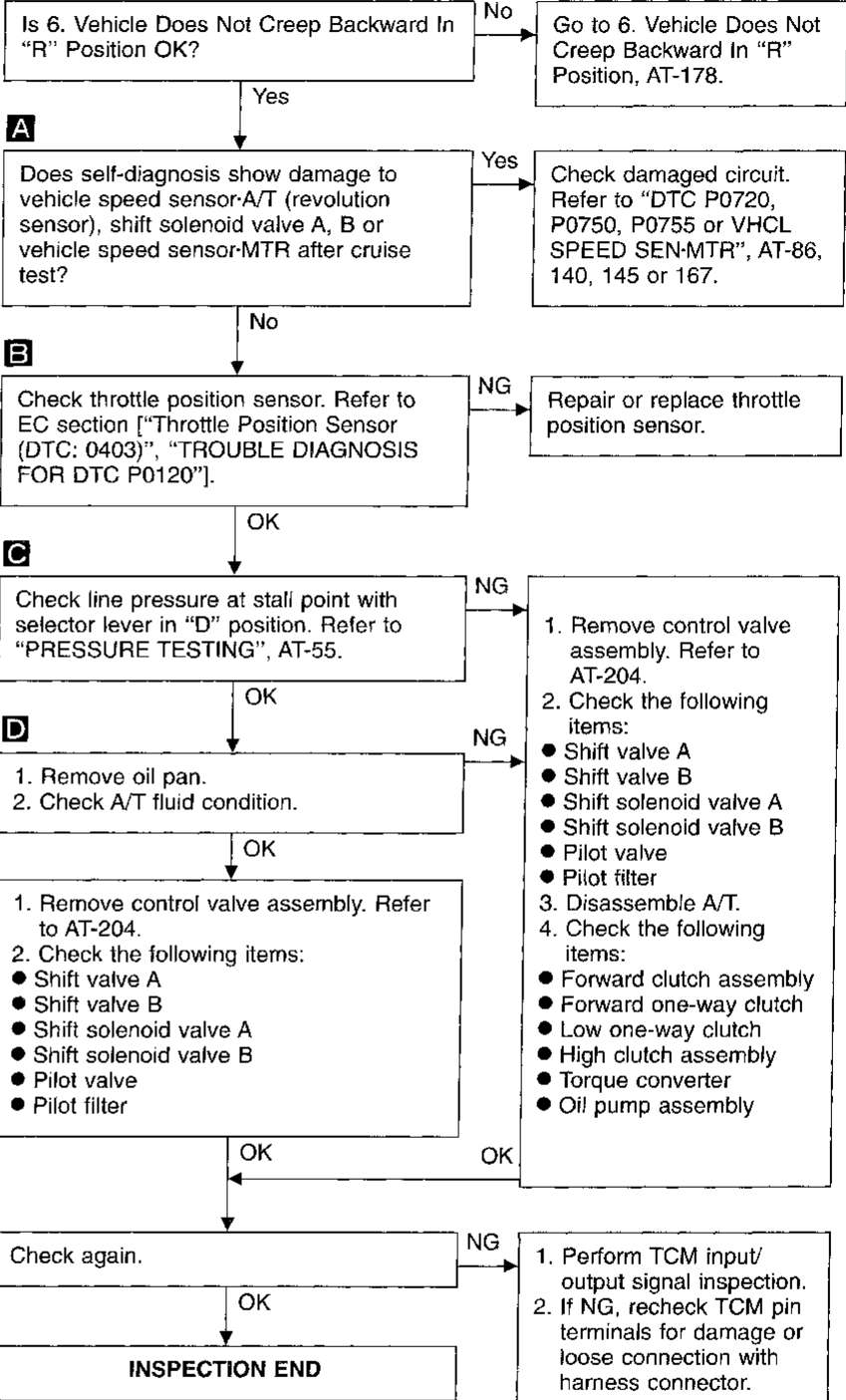
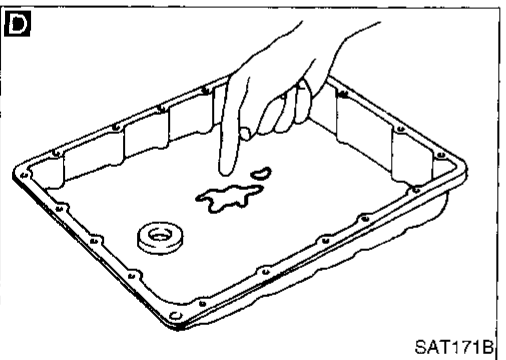
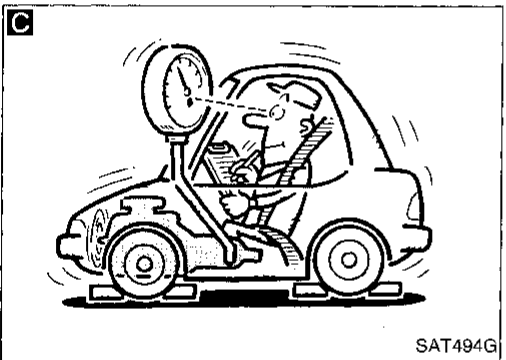
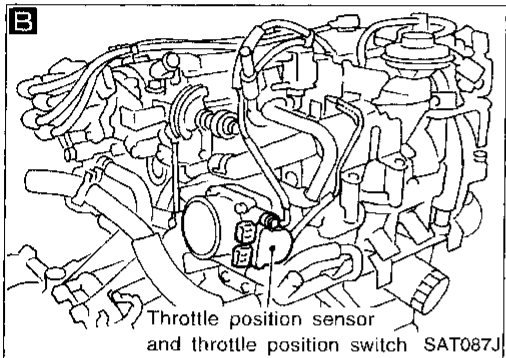
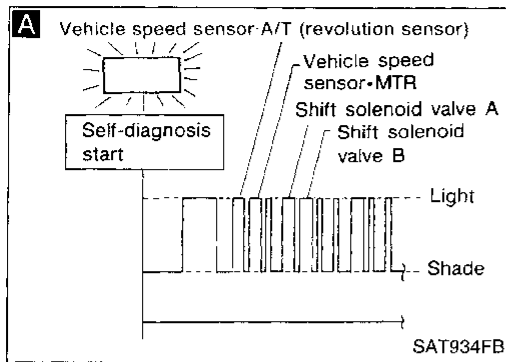

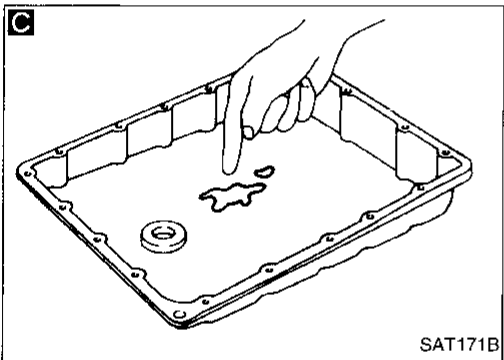
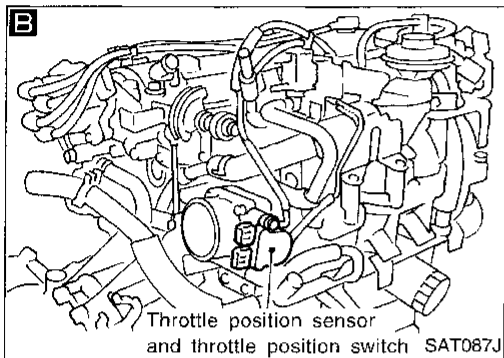
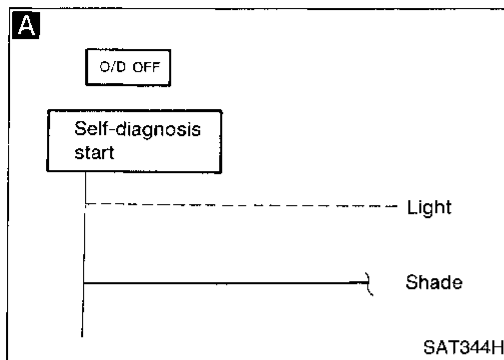

9. A/T Does Not Shift: D₁ → D₂ or Does Not Kickdown: D₄ → D₂

SYMPTOM:

A/T does not shift from D₁ to D₂ at the specified speed.
A/T does not shift from D₄ to D₂ when depressing accelerator pedal fully at the specified speed.

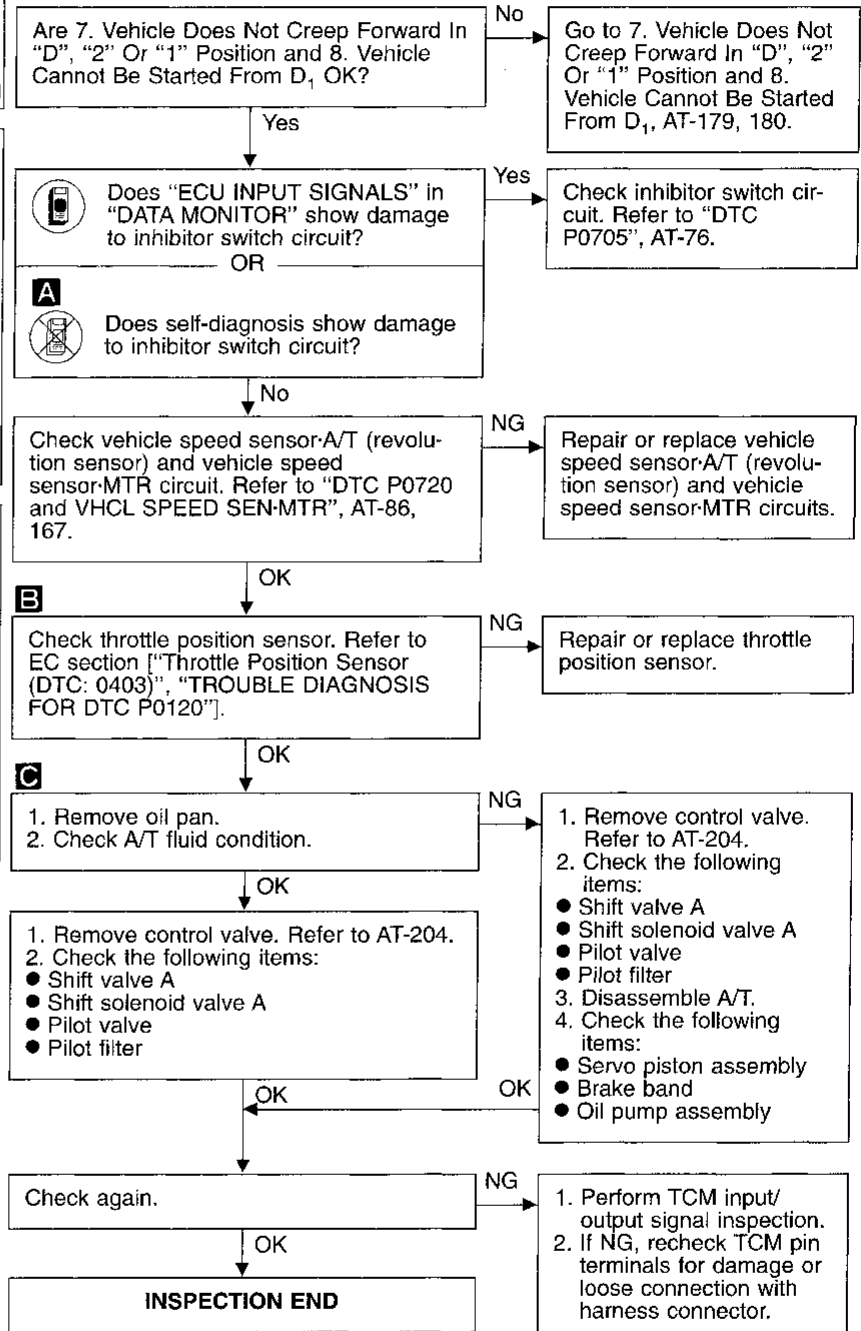

CI
MA
EM
LC
EC
FE
CL
MT
AT
FA
RA
BR
ST
RS
BT
HA
EL
IDX

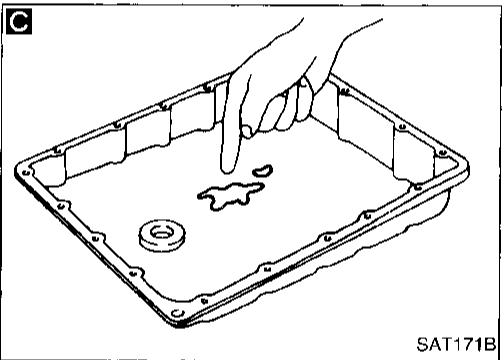
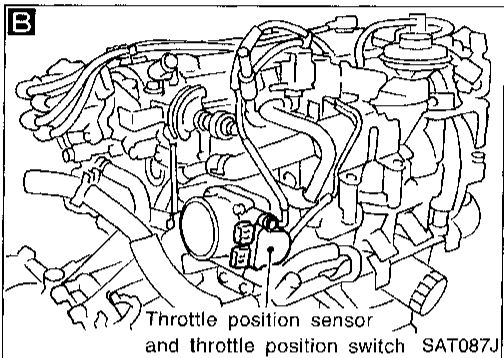
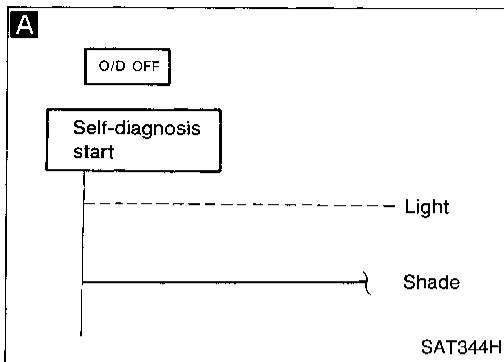

10. A/T Does Not Shift: D₂ → D₃

SYMPTOM:

A/T does not shift from D₂ to D₃ at the specified speed.

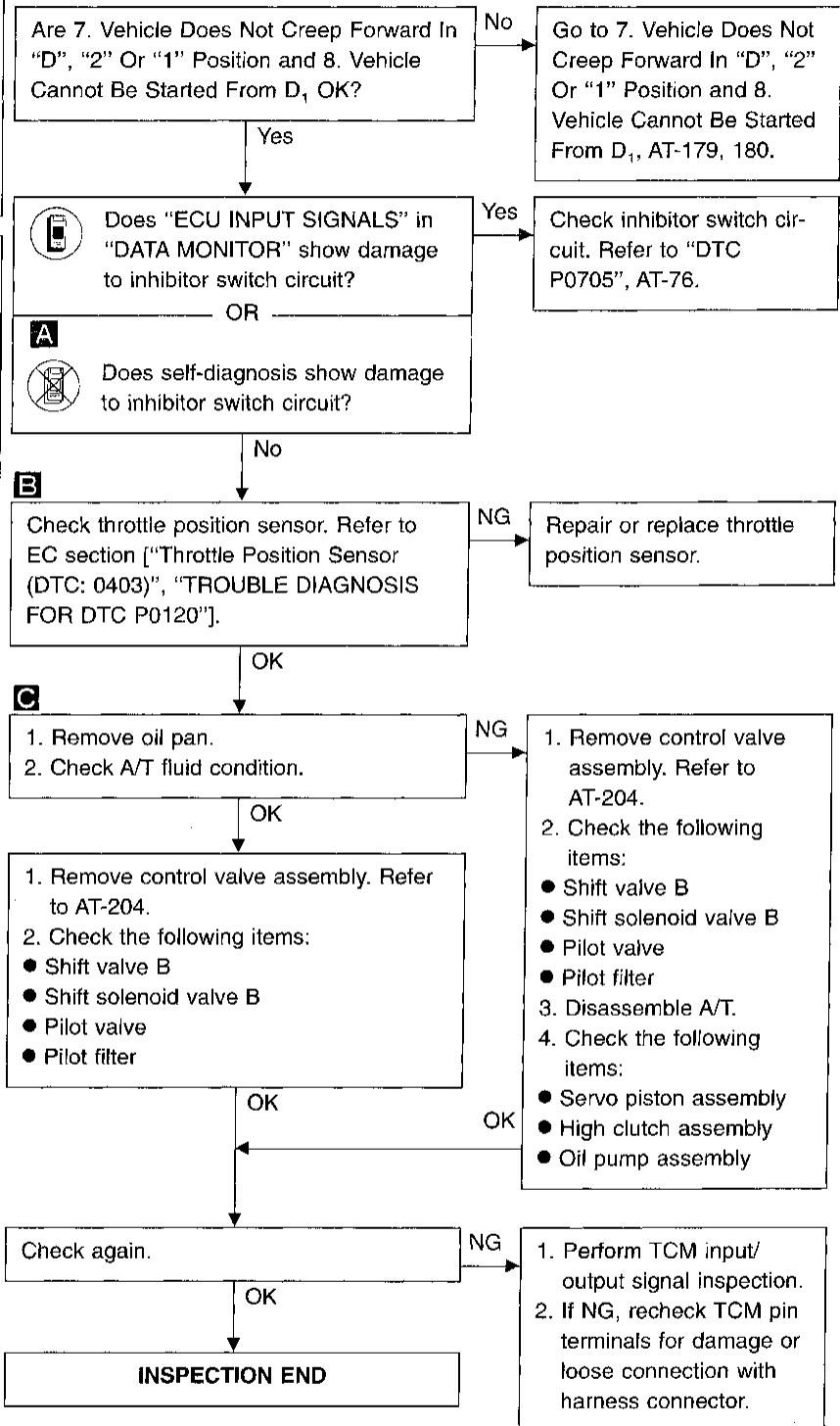

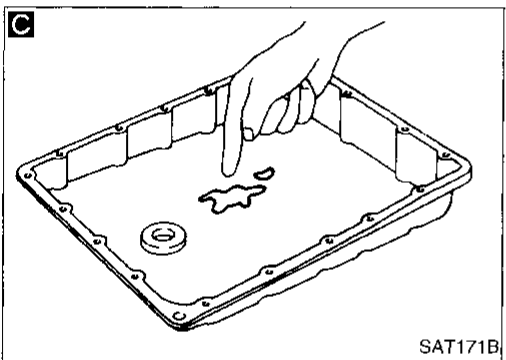
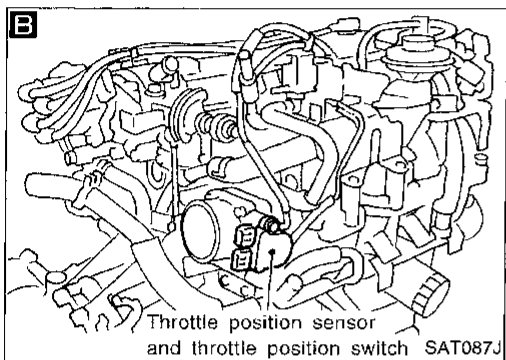
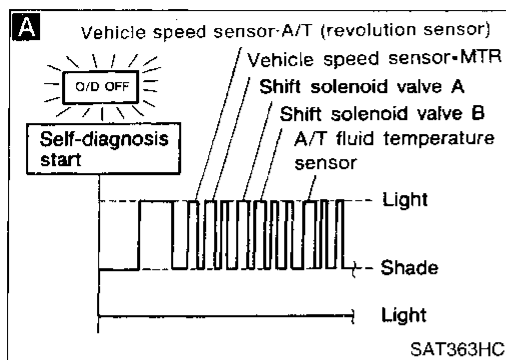

11. A/T Does Not Shift: D₃ → D₄

SYMPTOM:

- A/T does not shift from D₃ to D₄ at the specified speed.
- A/T must be warm before D₃ to D₄ shift will occur.

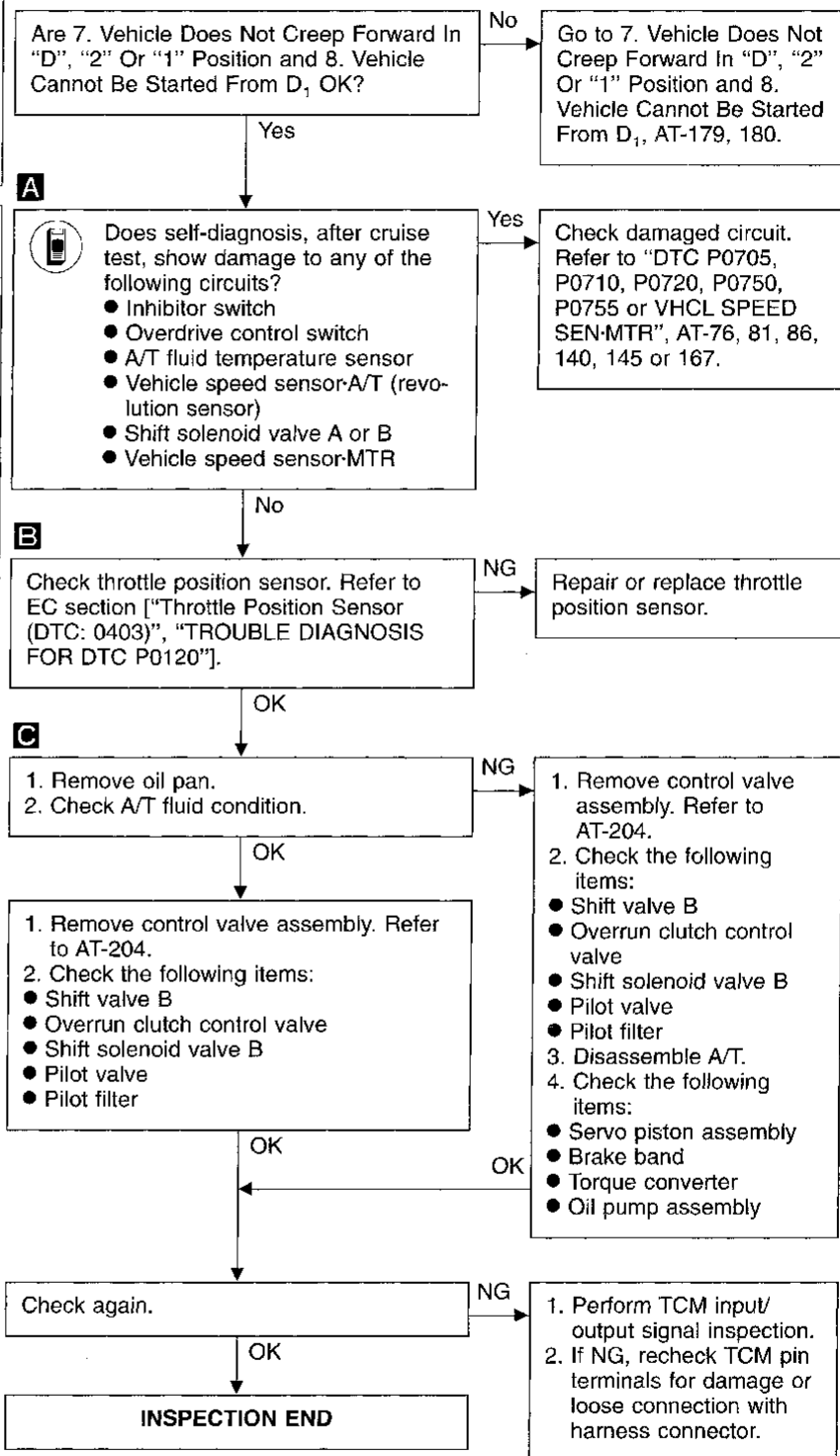

CI
 MA
 EM
 LG
 EC
 FE
 CL
 MT
 AT
 FA
 RA
 BR
 ST
 RS
 BT
 HA
 EL
 IOX

12. A/T Does Not Perform Lock-up

SYMPTOM:

A/T does not perform lock-up at the specified speed.

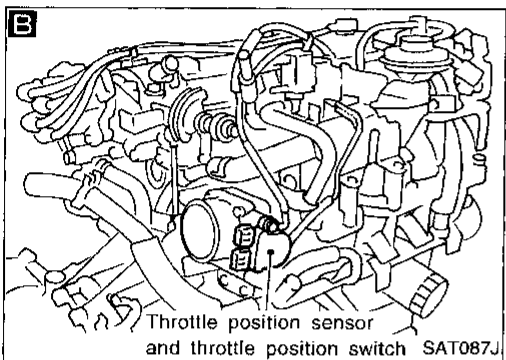
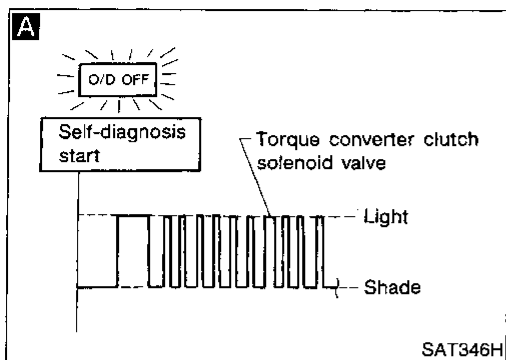

A

Does self-diagnosis show damage to torque converter clutch solenoid valve circuit after cruise test?

Yes

Check torque converter clutch solenoid valve circuit. Refer to "DTC P0740", AT-122.

No

B

Check throttle position sensor. Refer to EC section ["Throttle Position Sensor (DTC: 0403)", "TROUBLE DIAGNOSIS FOR DTC P0120"].

NG

Repair or replace throttle position sensor.

OK

1. Remove control valve. Refer to AT-204.
2. Check following items:

- Torque converter clutch control valve
- Torque converter relief valve
- Torque converter clutch solenoid valve
- Pilot valve
- Pilot filter

NG

Repair or replace damaged parts.

OK

Check again.

NG

1. Perform TCM input/output signal inspection.
2. If NG, recheck TCM pin terminals for damage or loose connection with harness connector.

OK

INSPECTION END

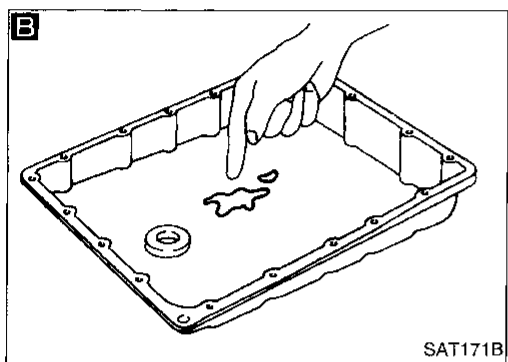
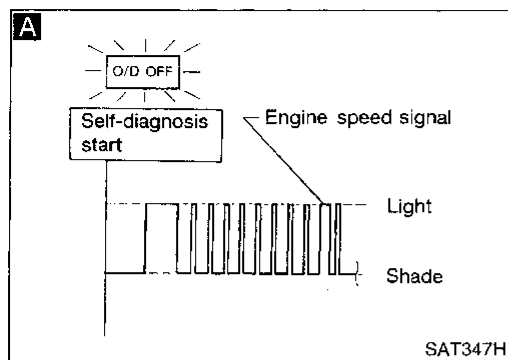

13. A/T Does Not Hold Lock-up Condition

SYMPTOM:

A/T does not hold lock-up condition for more than 30 seconds.

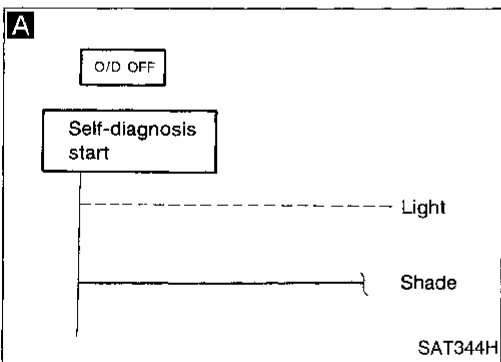
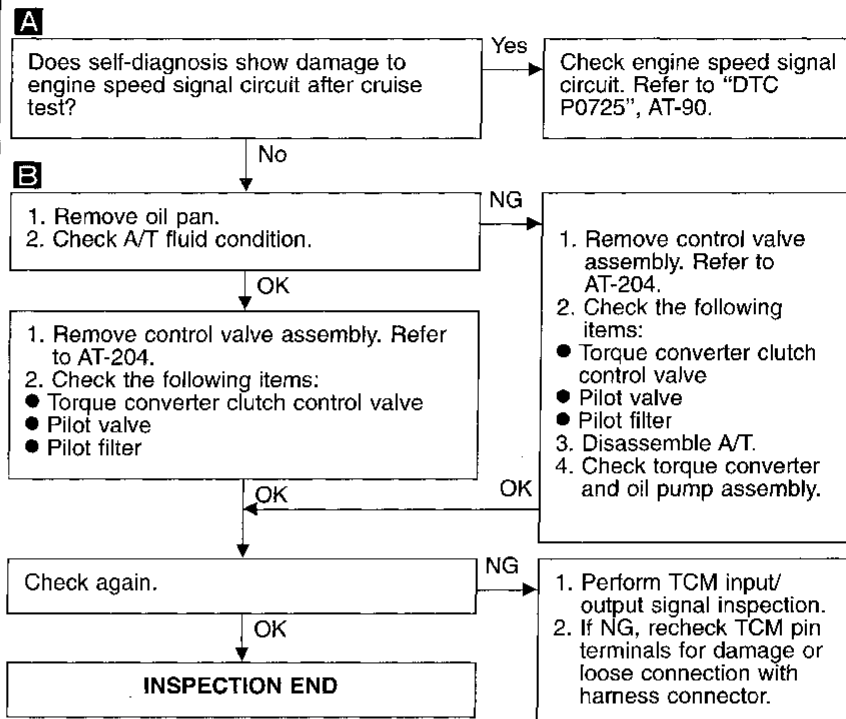

14. Lock-up Is Not Released

SYMPTOM:

Lock-up is not released when accelerator pedal is released.

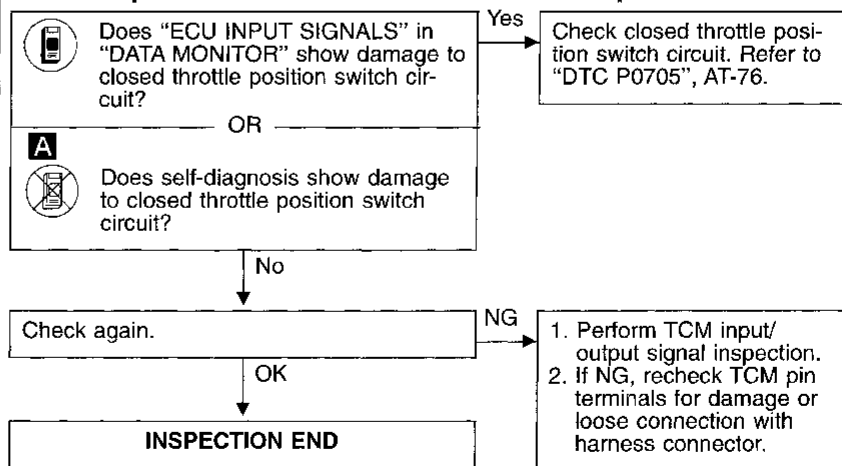

15. Engine Speed Does Not Return To Idle (Light Braking D₄ → D₃)

SYMPTOM:

- Engine speed does not smoothly return to idle when A/T shifts from D₄ to D₃.
- Vehicle does not decelerate by engine brake when turning overdrive control switch OFF.
- Vehicle does not decelerate by engine brake when shifting A/T from "D" to "2" position.

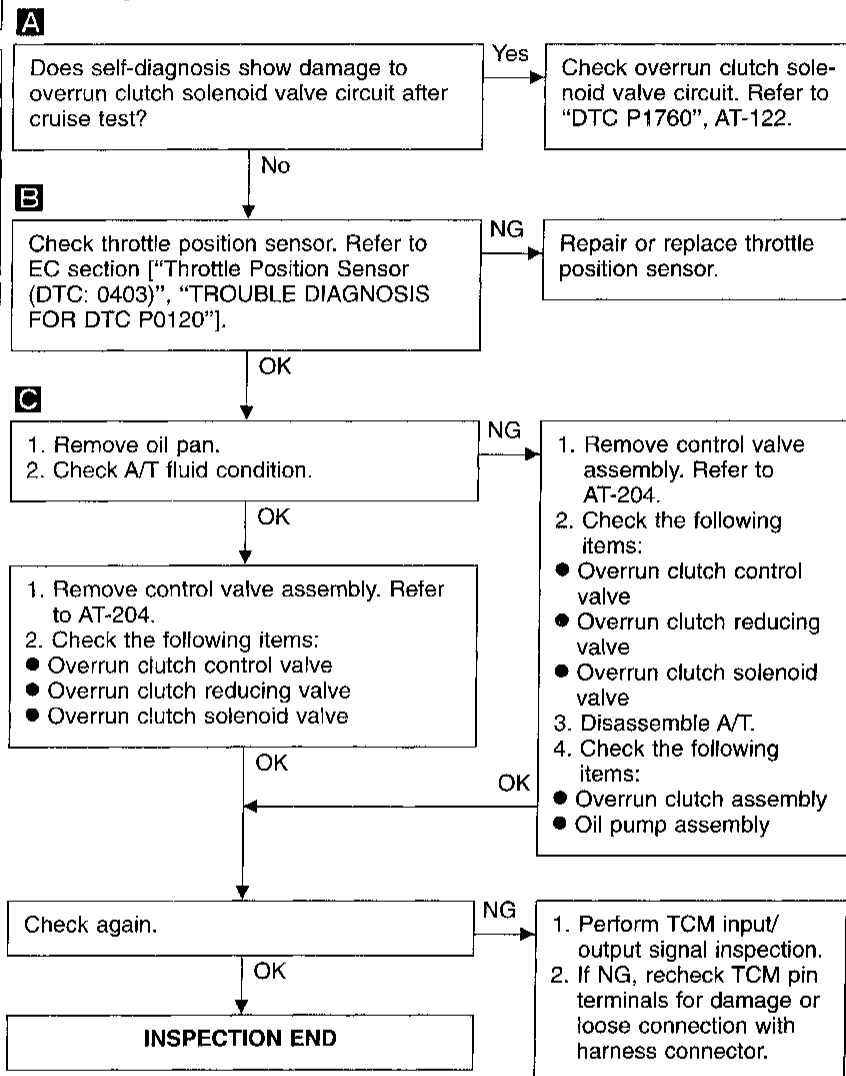
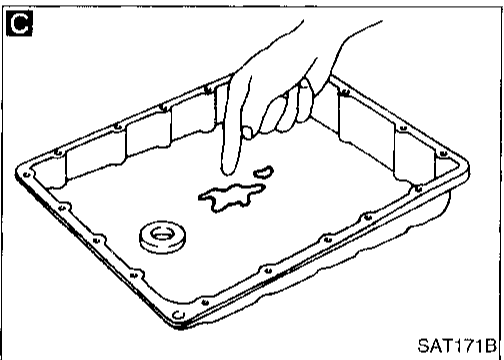
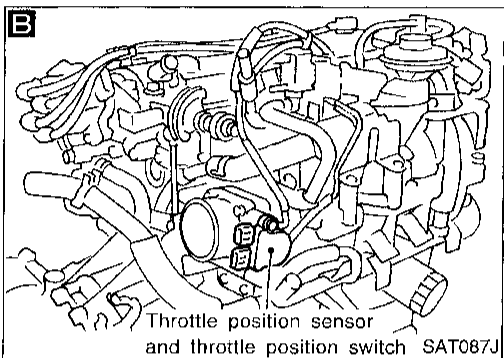
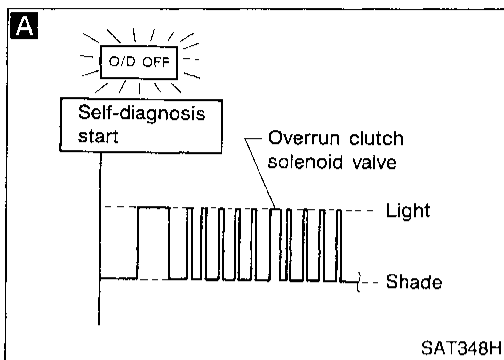

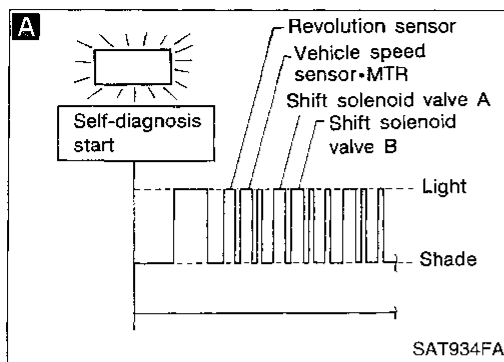

16. Vehicle Does Not Start From D₁

SYMPTOM:

Vehicle does not start from D₁ on Cruise test — Part 2.

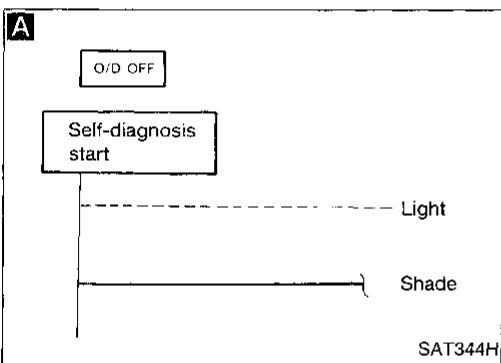
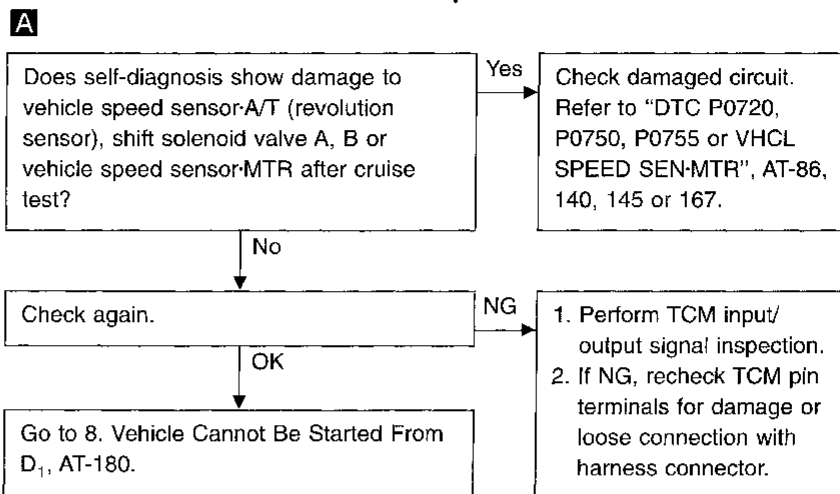

17. A/T Does Not Shift: D₄ → D₃, When Overdrive Control Switch "ON" → "OFF"

SYMPTOM:

A/T does not shift from D₄ to D₃ when changing overdrive control switch to "OFF" position.

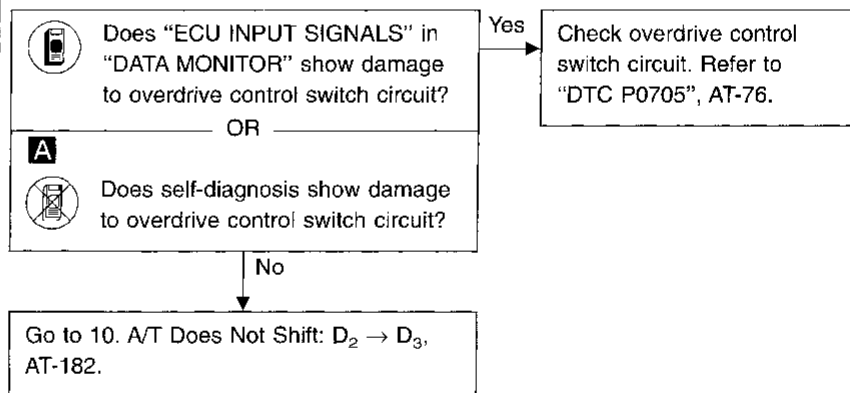

GI

MA

EM

LC

EC

FE

CL

MT

AT

FA

RA

BR

ST

RS

BT

HA

EL

IDX

TROUBLE DIAGNOSES FOR SYMPTOMS

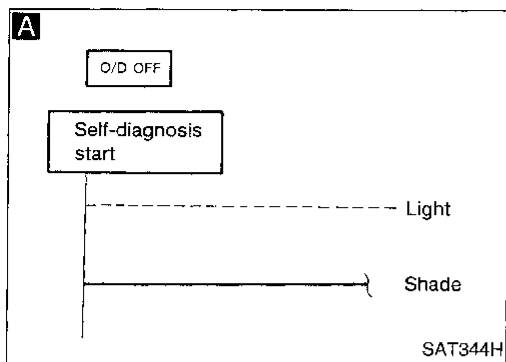

18. A/T Does Not Shift: $D_3 \rightarrow 2_2$, When Selector Lever "D" \rightarrow "2" Position

SYMPTOM:

A/T does not shift from D_3 to 2_2 when changing selector lever from "D" to "2" position.

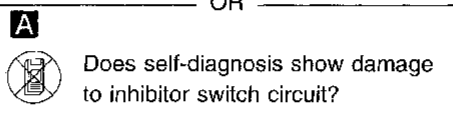
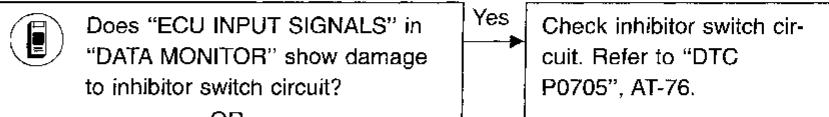

Go to 9. A/T Does Not Shift: $D_1 \rightarrow D_2$ Or Does Not Kickdown: $D_4 \rightarrow D_2$, AT-181.

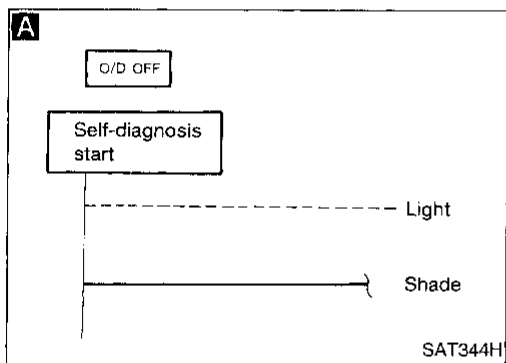

19. A/T Does Not Shift: $2_2 \rightarrow 1_1$, When Selector Lever "2" \rightarrow "1" Position

SYMPTOM:

A/T does not shift from 2_2 to 1_1 when changing selector lever from "2" to "1" position.

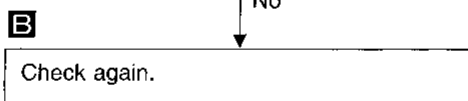
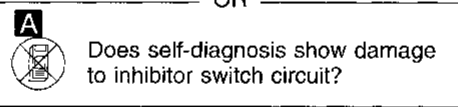
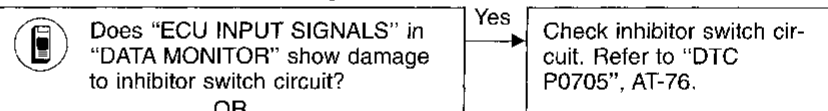

1. Perform TCM input/output signal inspection.
2. If NG, recheck TCM pin terminals for damage or loose connection with harness connector.

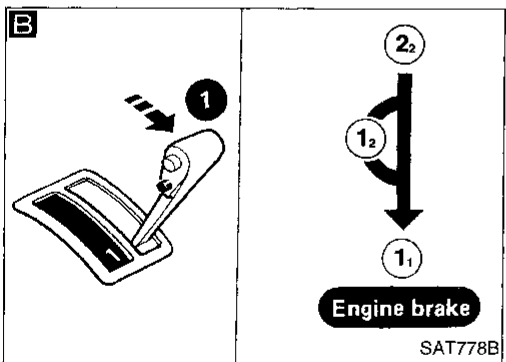

20. Vehicle Does Not Decelerate By Engine Brake

SYMPTOM:

Vehicle does not decelerate by engine brake when shifting from 2₂ (1₂) to 1₁.

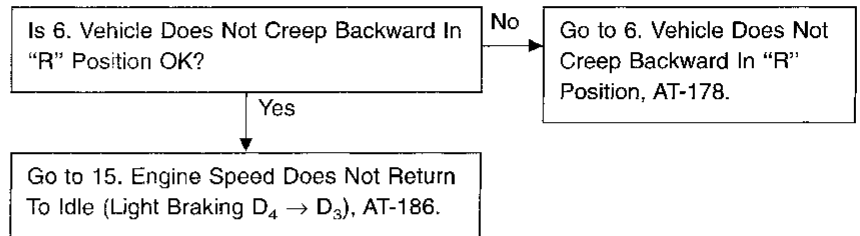

GI
MA
EM
LC
EC
FE
CL
MT
AT
FA
RA
BR
ST
RS
BT
HA
EL
IDX

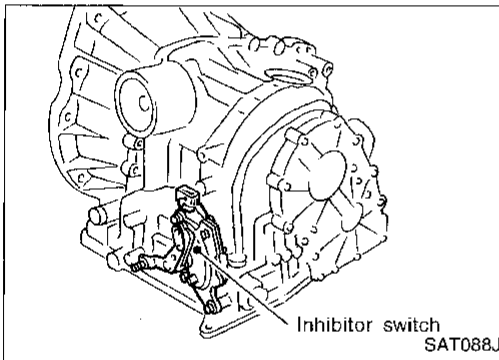

21. TCM Self-diagnosis Does Not Activate (Inhibitor, Overdrive Control and Throttle Position Switch Circuit Checks)

SYMPTOM:

O/D OFF indicator lamp does not come on in TCM self-diagnostic procedure even if the lamp circuit is good.

DESCRIPTION

- Inhibitor switch
Detects the selector lever position and sends a signal to the TCM.
- Overdrive control switch
Detects the overdrive control switch position (ON or OFF) and sends a signal to the TCM.
- Throttle position switch
Consists of a wide open throttle position switch and a closed throttle position switch.
The wide open throttle position switch sends a signal to the TCM when the throttle valve is open at least 1/2 of the full throttle position. The closed throttle position switch sends a signal to the TCM when the throttle valve is fully closed.

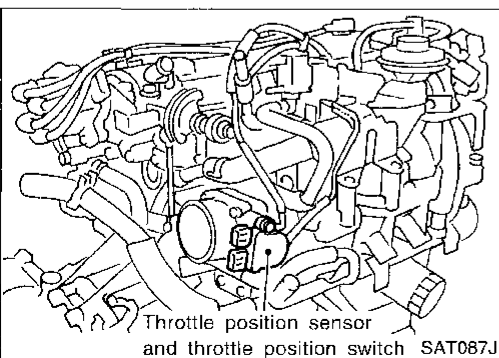
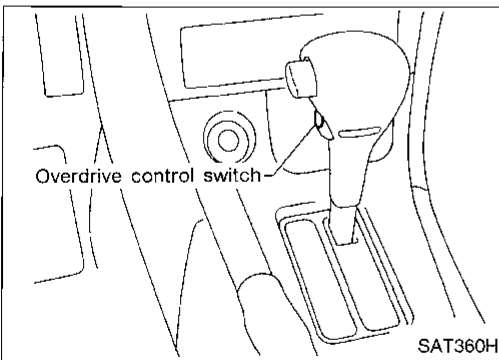

TROUBLE DIAGNOSES FOR SYMPTOMS

21. TCM Self-diagnosis Does Not Activate (Inhibitor, Overdrive Control and Throttle Position Switch Circuit Checks) (Cont'd)

TCM TERMINALS AND REFERENCE VALUE

Remarks: Specification data are reference values.







Terminal No.	Wire color	Item	Condition	Judgement standard
3	OR/B	O/D OFF indicator lamp	When setting overdrive control switch in "OFF" position.	1V or less
			When setting overdrive control switch in "ON" position.	Battery voltage
10*	Y/B	DT1	—	—
11*	Y/G	DT2	—	—
12*	Y/R	DT3	—	—
13*	G/OR	"N" position signal	When setting selector lever to "N" or "P" position.	1V or less
			When setting selector lever to other positions.	Approximately 5V
14	Y	Closed throttle position switch (in throttle position switch)	When releasing accelerator pedal after warming up engine.	Battery voltage
			When depressing accelerator pedal after warming up engine.	1V or less
16	OR/L	Inhibitor "1" position switch	When setting selector lever to "1" position.	Battery voltage
			When setting selector lever to other positions.	1V or less
17	B/Y	Inhibitor "2" position switch	When setting selector lever to "2" position.	Battery voltage
			When setting selector lever to other positions.	1V or less
18	W/G	Inhibitor "D" position switch	When setting selector lever to "D" position.	Battery voltage
			When setting selector lever to other positions.	1V or less
19	GY/R	Inhibitor "N" or "P" position switch	When setting selector lever to "N" or "P" position.	Battery voltage
			When setting selector lever to other positions.	1V or less
20	G	Inhibitor "R" position switch	When setting selector lever to "R" position.	Battery voltage
			When setting selector lever to other positions.	1V or less
21	LG	Wide open throttle position switch (in throttle position switch)	When depressing accelerator pedal more than half-way after warming up engine.	Battery voltage
			When releasing accelerator pedal after warming up engine.	1V or less
28*	G/B	—	—	—
30*	GY/L	—	—	—



*: These terminals are connected to the ECM (ECCS control module).

TROUBLE DIAGNOSES FOR SYMPTOMS

21. TCM Self-diagnosis Does Not Activate (Inhibitor, Overdrive Control and Throttle Position Switch Circuit Checks) (Cont'd)

Terminal No.	Wire color	Item	Condition		Judgement standard
37	OR	ASCD cruise signal		When ASCD cruise is being performed. ("CRUISE" light comes on.)	Battery voltage
				When ASCD cruise is not being performed. ("CRUISE" light does not come on.)	1V or less
39	G/R	Overdrive control switch	 	When setting overdrive control switch in "ON" position	Battery voltage
				When setting overdrive control switch in "OFF" position	1V or less
40	W/B	ASCD OD cut signal		When "ACCEL" set switch on ASCD cruise is in "D ₄ " position.	5 - 8V
				When "ACCEL" set switch on ASCD cruise is in "D ₃ " position.	1V or less
45*	PU	OBD-II output	 	—	—

*: These terminals are connected to the ECM (ECCS control module).

GI
MA
EM
LC
EC
FE
CL
MT
AT
FA
RA
BR
ST
RS
BT
HA
EL
IDX

TROUBLE DIAGNOSES FOR SYMPTOMS

21. TCM Self-diagnosis Does Not Activate (Inhibitor, Overdrive Control and Throttle Position Switch Circuit Checks) (Cont'd)

DIAGNOSTIC PROCEDURE

A

☆MONITOR	☆NO FAIL	<input type="checkbox"/>
VHCL/S SE·A/T	0km/h	
VHCL/S SE·MTR	5km/h	
THRTL POS SEN	0.4V	
FLUID TEMP SE	1.2V	
BATTERY VOLT	13.4V	
ENGINE SPEED	1024rpm	
OVERDRIVE SW	O N	
P/N POSI SW	O N	
R POSITION SW	OFF	

RECORD

SAT076H

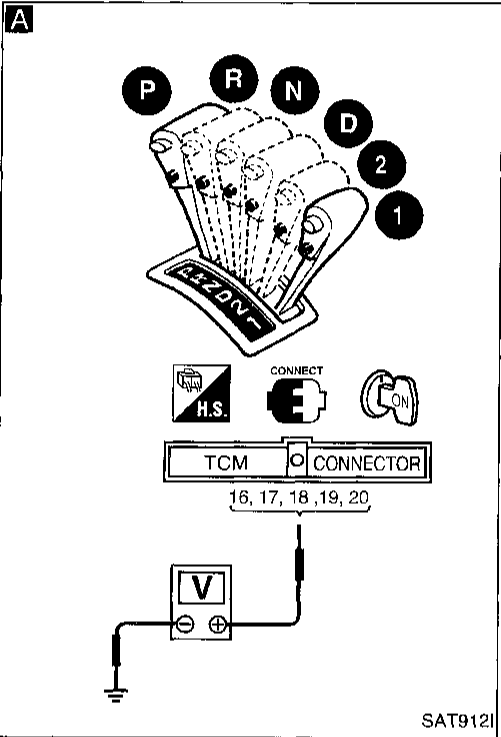

CHECK INHIBITOR SWITCH CIRCUIT.



1. Turn ignition switch to "ON" position. (Do not start engine.)
 2. Select "ECU INPUT SIGNALS" in "DATA MONITOR" mode for "A/T" with CONSULT.
 3. Read out "P/N", "R", "D", "2" and "1" position switches moving selector lever to each position.
- Check that the signal of the selector lever position is indicated properly.

NG

- Check the following items:
- Inhibitor switch (Refer to "Component Inspection", AT-195.)
 - Harness for short or open between ignition switch and inhibitor switch (Main harness)
 - Harness for short or open between inhibitor switch and TCM (Main harness)

OR



1. Turn ignition switch to "ON" position. (Do not start engine.)
2. Check voltage between TCM terminals ①⑥, ①⑦, ①⑧, ①⑨, ②⑩ and ground while moving selector lever through each position.

Voltage:

B: Battery voltage
0: 0V

Lever position	Terminal No.				
	①⑨	②⑩	①⑧	①⑦	①⑥
P, N	B	0	0	0	0
R	0	B	0	0	0
D	0	0	B	0	0
2	0	0	0	B	0
1	0	0	0	0	B

OK



(Go to next page.)

TROUBLE DIAGNOSES FOR SYMPTOMS

21. TCM Self-diagnosis Does Not Activate (Inhibitor, Overdrive Control and Throttle Position Switch Circuit Checks) (Cont'd)

B

☆MONITOR	☆NO FAIL	
VHCL/S SE-A/T	0km/h	
VHCL/S SE-MTR	5km/h	
THRTL POS SEN	0.4V	
FLUID TEMP SE	1.2V	
BATTERY VOLT	13.4V	
ENGINE SPEED	1024rpm	
OVERDRIVE SW	O N	
P/N POSI SW	O N	
R POSITION SW	OFF	

RECORD

SAT076H

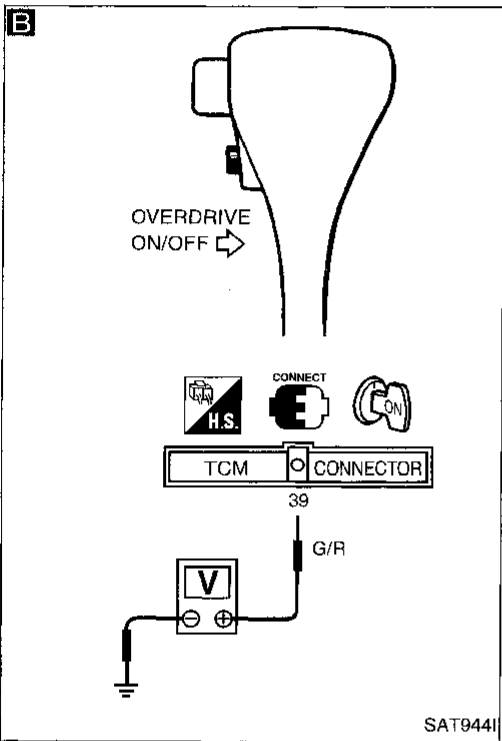

B

CHECK OVERDRIVE CONTROL SWITCH CIRCUIT.

1. Turn ignition switch to "ON" position.
(Do not start engine.)

2. Select "ECU INPUT SIGNALS" in "DATA MONITOR" mode for "A/T" with CONSULT.

3. Read out "OVERDRIVE SWITCH".
Check the signal of the overdrive control switch is indicated properly.
(Overdrive control switch "ON" displayed on CONSULT means overdrive "OFF".)

OR

1. Turn ignition switch to "ON" position.
(Do not start engine.)

2. Check voltage between TCM terminal ③⑨ and ground when overdrive control switch is "ON" and "OFF".

Switch position	Voltage
ON	Battery voltage
OFF	1V or less

NG

Check the following items:

- Overdrive control switch (Refer to "Component Inspection", AT-195.)
- Harness for short or open between TCM and overdrive control switch (Main harness)
- Harness of ground circuit for overdrive control switch (Main harness) for short or open

OK

OK

B

(Go to next page.)

GI

MA

EM

LC

EC

FE

CL

MT

AT

FA

RA

BR

ST

RS

BT

HA

EL

IDX

TROUBLE DIAGNOSES FOR SYMPTOMS

21. TCM Self-diagnosis Does Not Activate (Inhibitor, Overdrive Control and Throttle Position Switch Circuit Checks) (Cont'd)

C

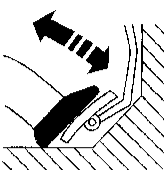

☆ MONITOR	☆ NO FAIL	↕
D POSITION SW	OFF	
2 POSITION SW	OFF	
1 POSITION SW	OFF	
ASCD • CRUISE	OFF	
ASCD • OD CUT	OFF	
KICKDOWN SW	OFF	
POWERSHIFT SW	OFF	
CLOSED THL/SW	ON	
W/O THRL/P-SW	OFF	

RECORD

SAT963H

C

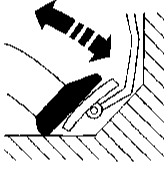
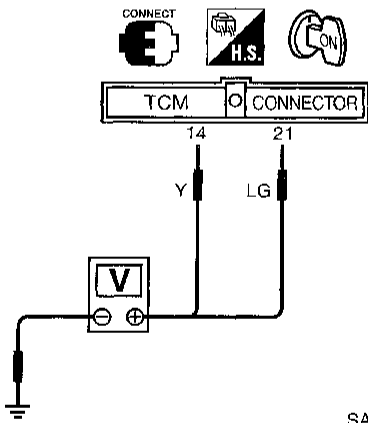
SAT945I

B

C

CHECK THROTTLE POSITION SWITCH CIRCUIT.

- Turn ignition switch to "ON" position. (Do not start engine.)
- Select "ECU INPUT SIGNALS" in "DATA MONITOR" mode for "A/T" with CONSULT.
- Read out "CLOSED THL/SW" and "W/O THRL/P-SW" depressing and releasing accelerator pedal. Check the signal of throttle position switch is indicated properly.

Check the following items:

- Throttle position switch — Refer to "Component Inspection", AT-196.
- Harness for short or open between ignition switch and throttle position switch (Main harness)
- Harness for short or open between throttle position switch and TCM (Main harness)

Accelerator pedal condition	Data monitor	
	CLOSED THL/SW	W/O THRL/P-SW
Released	ON	OFF
Fully depressed	OFF	ON

OR

- Turn ignition switch to "ON" position. (Do not start engine.)
- Check voltage between TCM terminals (14), (21) and ground while depressing, and releasing accelerator pedal slowly. (After warming up engine)

Accelerator pedal condition	Voltage	
	Terminal No. (14)	Terminal No. (21)
Released	Battery voltage	1V or less
Fully depressed	1V or less	Battery voltage

Perform self-diagnosis again after driving for a while.

INSPECTION END

TROUBLE DIAGNOSES FOR SYMPTOMS

21. TCM Self-diagnosis Does Not Activate (Inhibitor, Overdrive Control and Throttle Position Switch Circuit Checks) (Cont'd)

COMPONENT INSPECTION

Overdrive control switch

- Check continuity between two terminals.

Switch position	Continuity
ON	No
OFF	Yes

GI

MA

EM

LC

EC

FE

CL

MT

AT

FA

RA

BR

ST

RS

BT

HA

EL

IDX

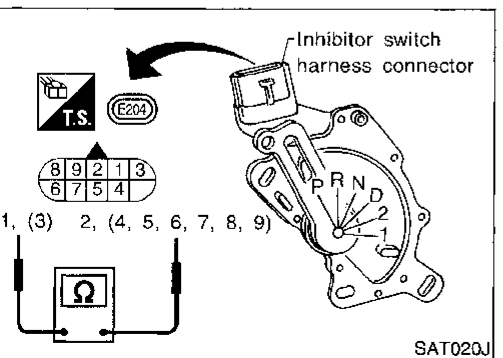
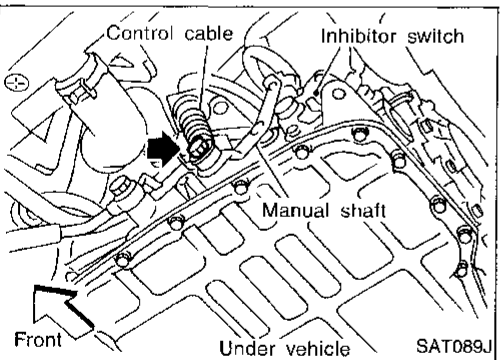
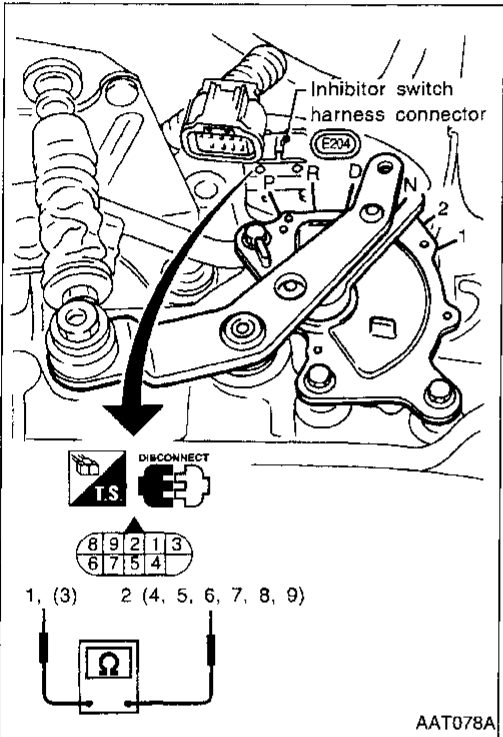
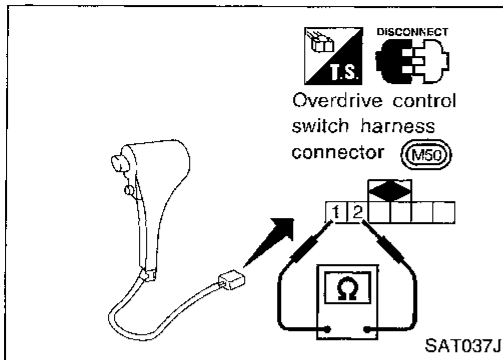

Inhibitor switch

1. Check continuity between terminals ① and ② and between terminals ③ and ④, ⑤, ⑥, ⑦, ⑧, ⑨ while moving manual shaft through each position.

Lever position	Terminal No.	
P	① — ②	③ — ⑨
R	③ — ⑧	
N	① — ②	③ — ⑦
D	③ — ⑥	
2	③ — ⑤	
1	③ — ④	

2. If NG, check again with manual control cable disconnected from manual shaft of A/T assembly. Refer to step 1.
3. If OK on step 2, adjust manual control cable. Refer to AT-206.

4. If NG on step 2, remove inhibitor switch from A/T and check continuity of inhibitor switch terminals. Refer to step 1.
5. If OK on step 4, adjust inhibitor switch. Refer to AT-205.
6. If NG on step 4, replace inhibitor switch.

TROUBLE DIAGNOSES FOR SYMPTOMS

21. TCM Self-diagnosis Does Not Activate (Inhibitor, Overdrive Control and Throttle Position Switch Circuit Checks) (Cont'd)

Throttle position switch

Closed throttle position switch (idle position)

- Check continuity between terminals ⑤ and ⑥.

Accelerator pedal condition	Continuity
Released	Yes
Depressed	No

- To adjust closed throttle position switch, refer to EC section ("Basic Inspection", "TROUBLE DIAGNOSIS — Basic Inspection").

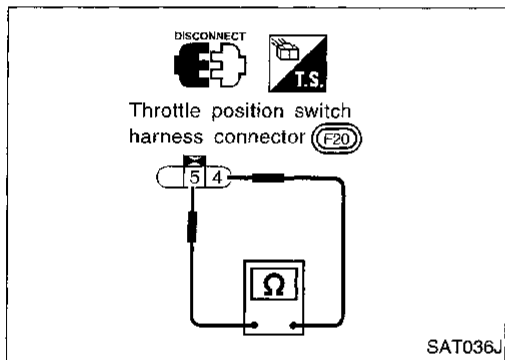
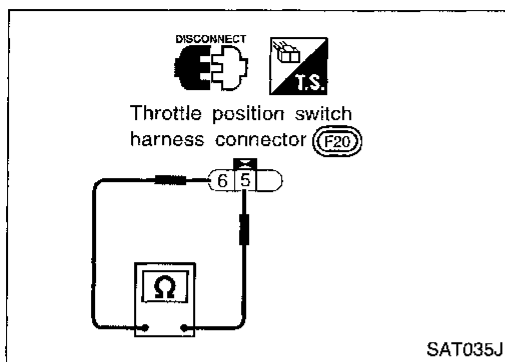

Wide open throttle position switch

- Check continuity between terminals ④ and ⑤.

Accelerator pedal condition	Continuity
Released	No
Depressed	Yes

TROUBLE DIAGNOSES — A/T Shift Lock System

Description

- The mechanical key interlock mechanism also operates as a shift lock:
With the key switch turned to ON, the selector lever cannot be shifted from "P" (parking) to any other position unless the brake pedal is depressed.
With the key removed, the selector lever cannot be shifted from "P" to any other position.
The key cannot be removed unless the selector lever is placed in "P".
- The shift lock and key interlock mechanisms are controlled by the ON-OFF operation of the shift lock solenoid and by the operation of the rotator and slider located inside the key cylinder.

Shift Lock System Electrical Parts Location

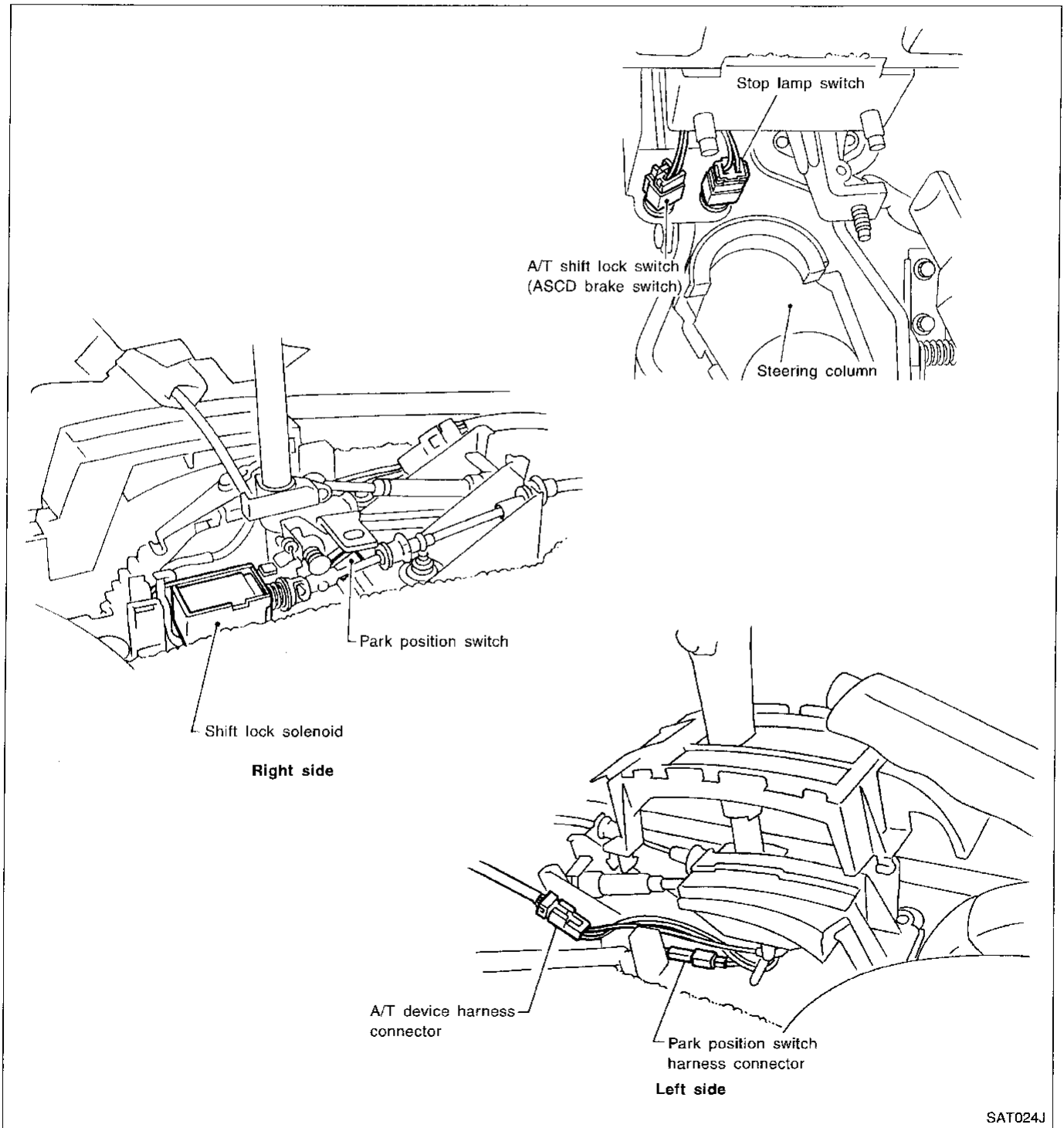

Wiring Diagram — SHIFT —

AT-SHIFT-01

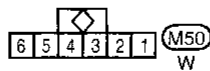
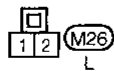
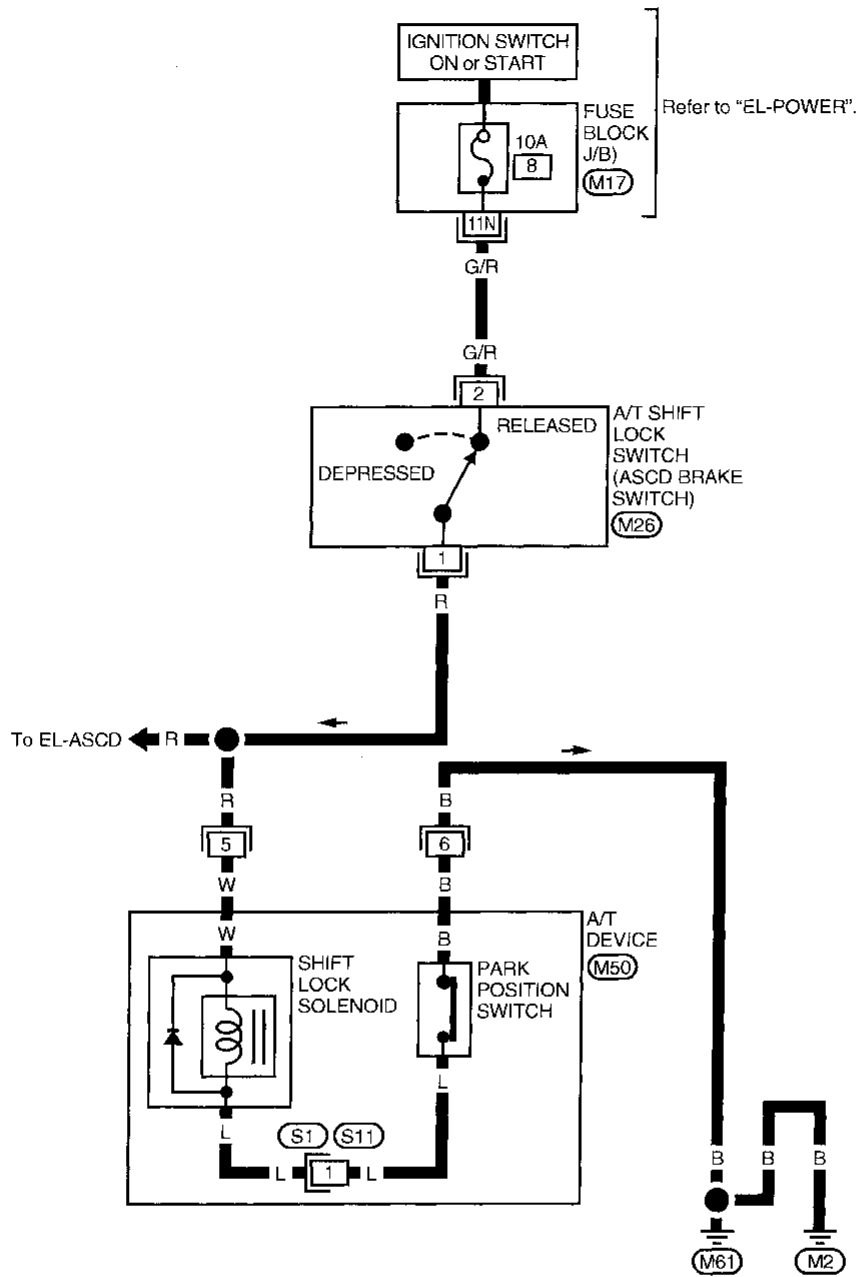

* This connector is not shown in "HARNESS LAYOUT " of EL section.

Diagnostic Procedure

SYMPTOM 1:

- Selector lever cannot be moved from "P" position with key in ON position and brake pedal applied.
- Selector lever can be moved from "P" position with key in ON position and brake pedal released.
- Selector lever can be moved from "P" position when key is removed from key cylinder.

SYMPTOM 2:

Ignition key cannot be removed when selector lever is set to "P" position. It can be removed when selector lever is set to any position except "P".

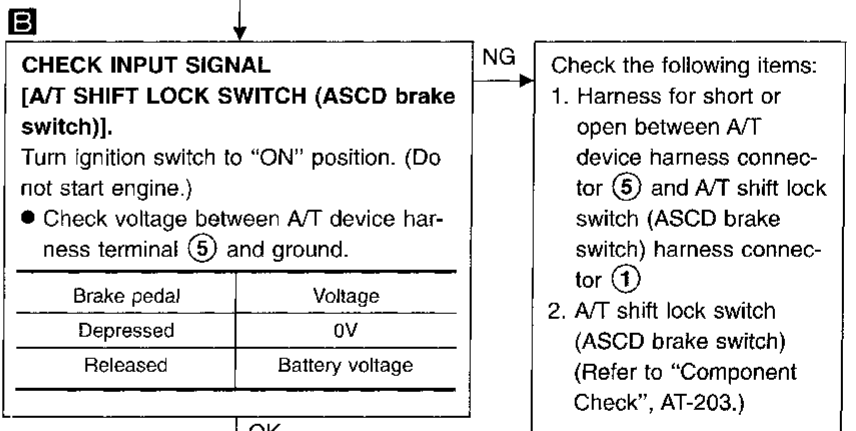
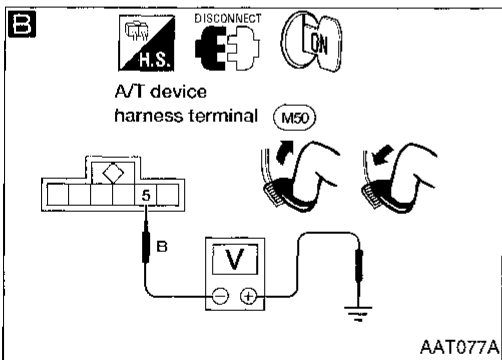
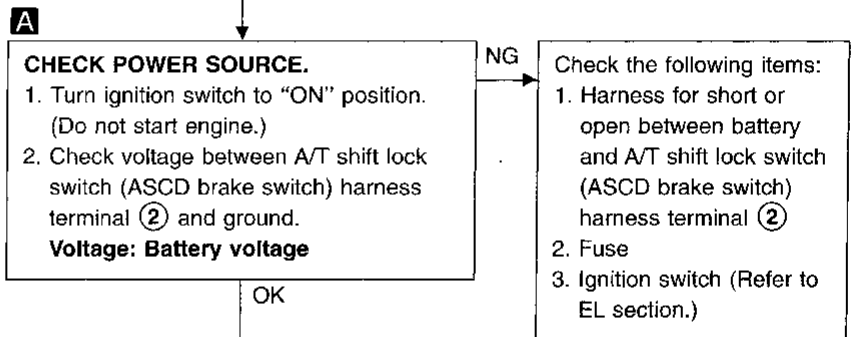
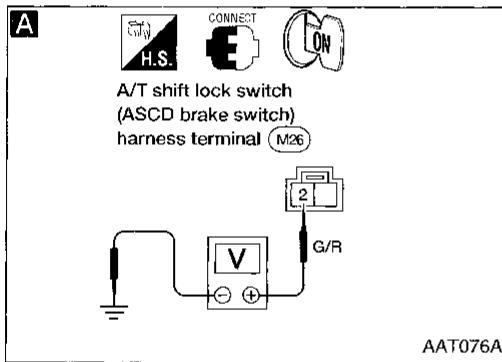
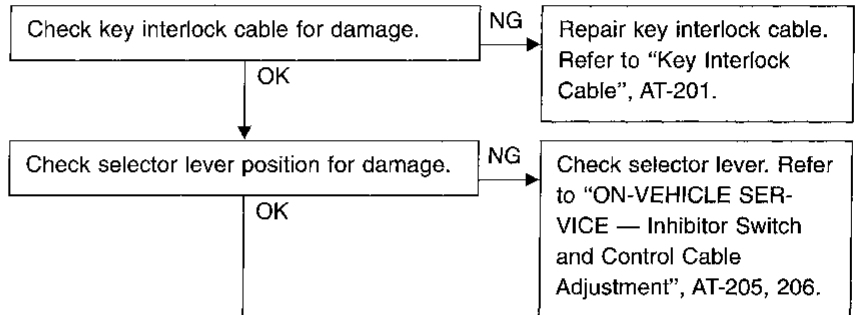

(Go to next page.)

TROUBLE DIAGNOSES — A/T Shift Lock System

Diagnostic Procedure (Cont'd)

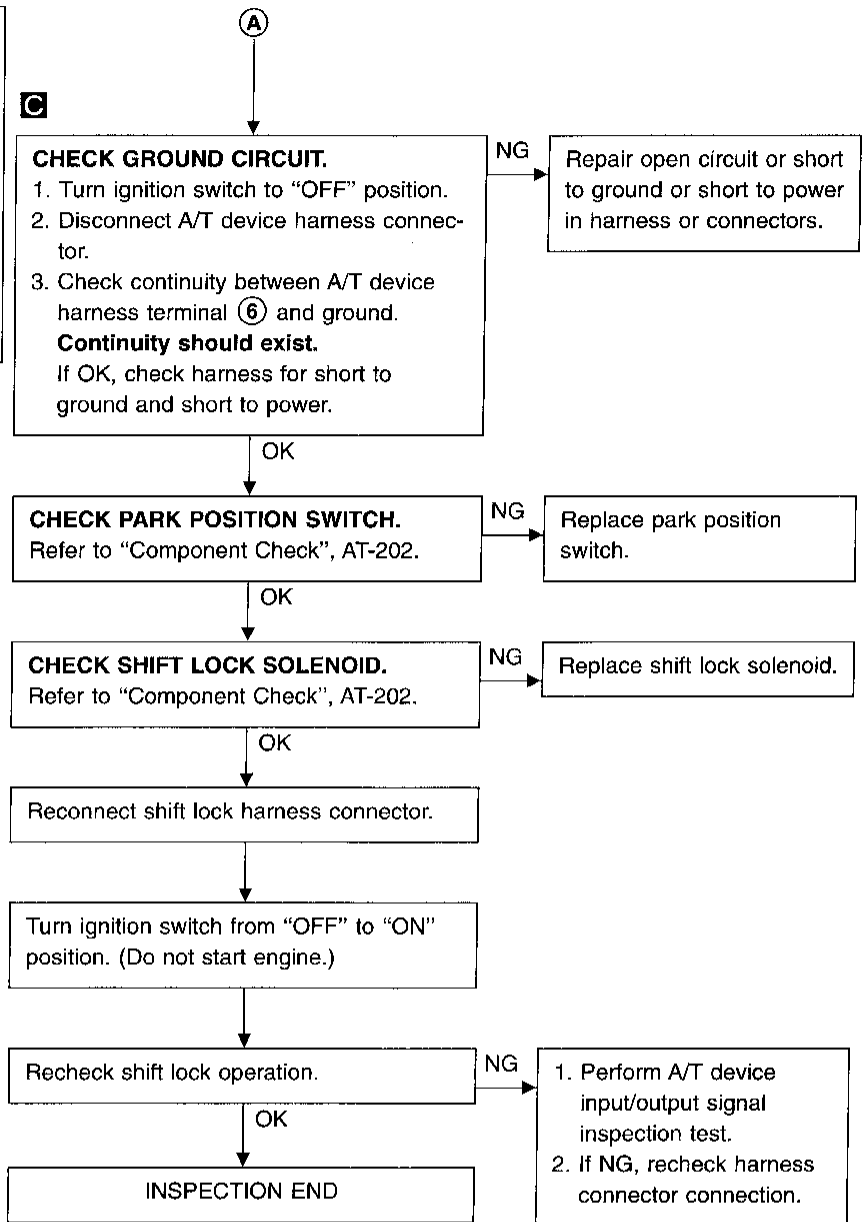
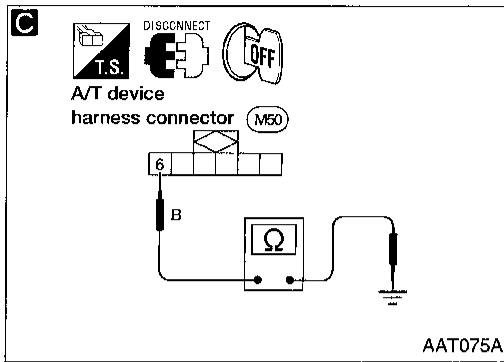

Key Interlock Cable

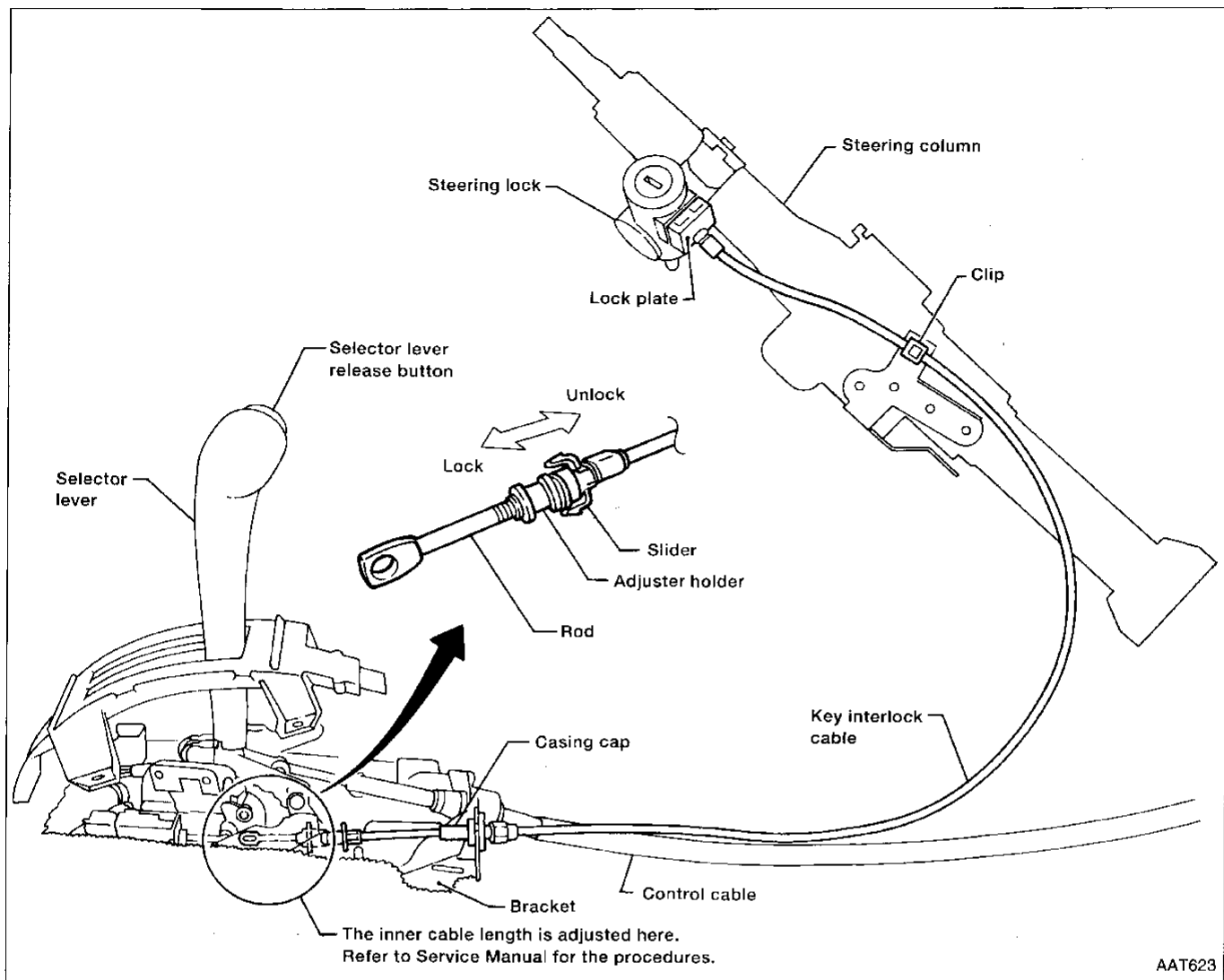

CAUTION:

- Install key interlock cable in such a way that it will not be damaged by sharp bends, twists or interference with adjacent parts.
- After installing key interlock cable to control device, make sure that casing cap and bracket are firmly secured in their positions. If casing cap can be removed with an external load of less than 39.2 N (4.0 kg, 8.8 lb), replace key interlock cable with new one.

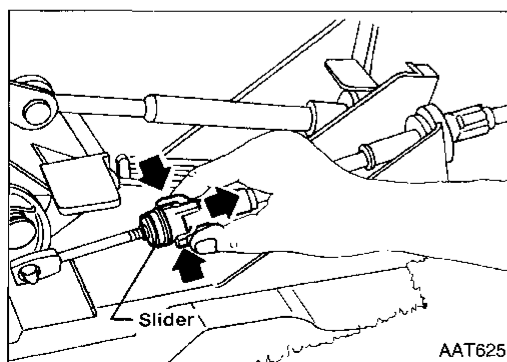

REMOVAL

Unlock slider from adjuster holder and remove rod from cable.

GI
MA
EM
LC
EC
FE
CL
MT
AT
FA
RA
BR
ST
RS
BT
HA
EL
IDX

TROUBLE DIAGNOSES — A/T Shift Lock System

Key Interlock Cable (Cont'd)

INSTALLATION

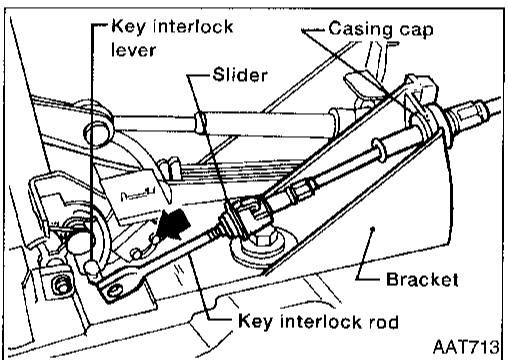
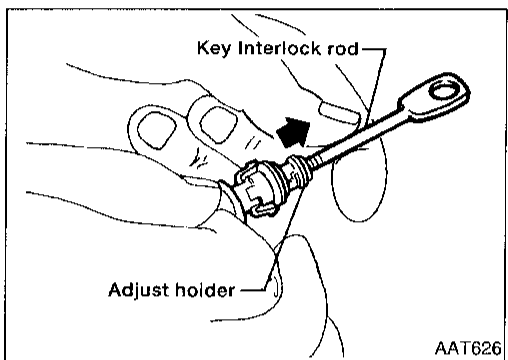
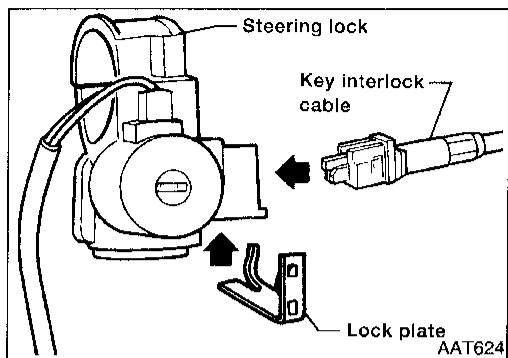

1. Remove key from key cylinder.
2. Set key interlock cable to steering lock assembly and install lock plate.
3. Clamp cable to steering column and fix to control cable with band.
4. Set control lever to "P" position.

5. Insert key interlock rod into adjuster holder.

6. Install casing cap to bracket.
7. Install key interlock rod to key interlock lever.
8. Move slider in order to fix adjuster holder to interlock rod.

Component Check

SHIFT LOCK SOLENOID

- Check operation by applying battery voltage to A/T device harness terminal ⑤ and shift lock solenoid harness terminal ①.

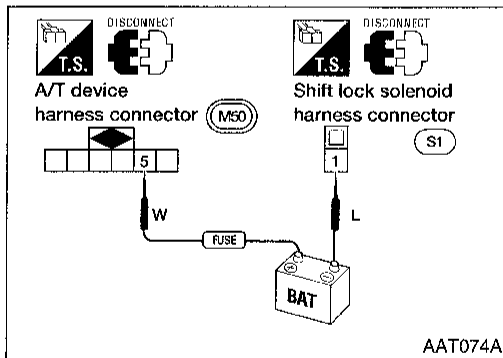

PARK POSITION SWITCH

- Check continuity between A/T device harness terminal ⑥ and park position switch harness terminal ①.

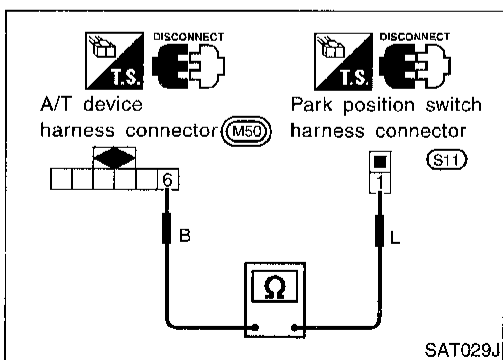

Condition	Continuity
When selector lever is set in "P" position and selector lever button is released	Yes
Except above	No

TROUBLE DIAGNOSES — A/T Shift Lock System

Component Check (Cont'd)

A/T SHIFT LOCK SWITCH (ASCD BRAKE SWITCH)

- Check continuity between terminals ① and ②.

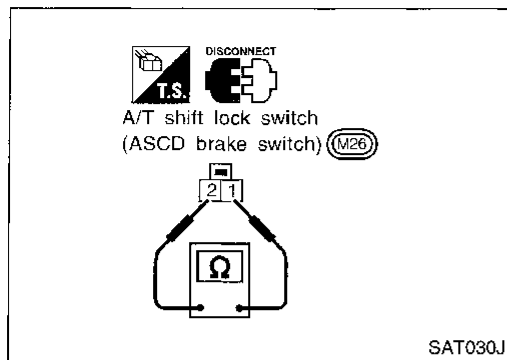

Condition	Continuity
When brake pedal is depressed	No
When brake pedal is released	Yes

Check A/T shift lock switch (ASCD brake switch) after adjusting brake pedal — refer to BR section (“Adjustment”, “BRAKE PEDAL AND BRACKET”).

GI

MA

EM

LG

EC

FE

CL

MT

AT

FA

RA

BR

ST

RS

BT

HA

EL

IDX

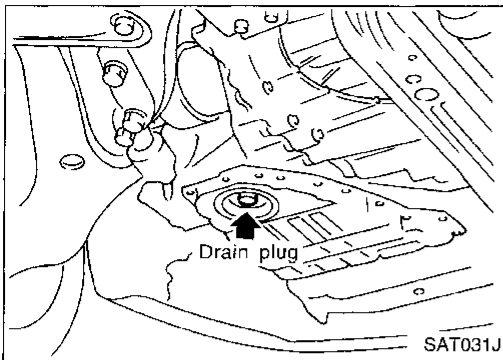

Control Valve Assembly and Accumulator REMOVAL

1. Drain ATF from transaxle.
2. Remove oil pan and gasket.

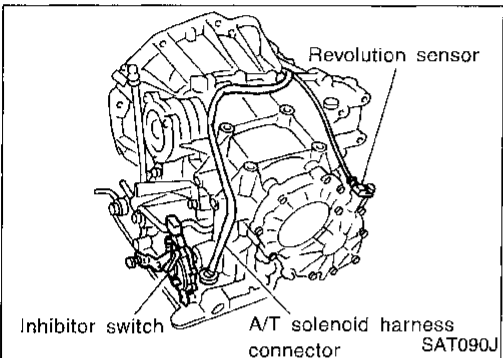

3. Disconnect A/T solenoid harness connector.

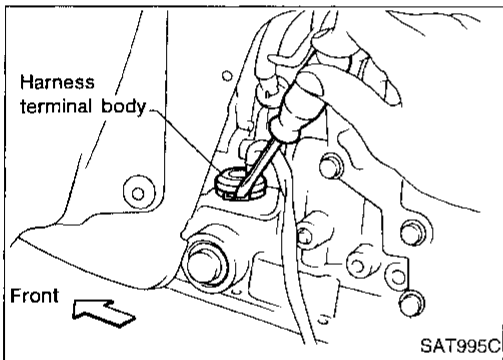

4. Remove stopper ring from terminal cord assembly harness terminal body.
5. Remove terminal cord assembly harness from transmission case by pushing on terminal body.

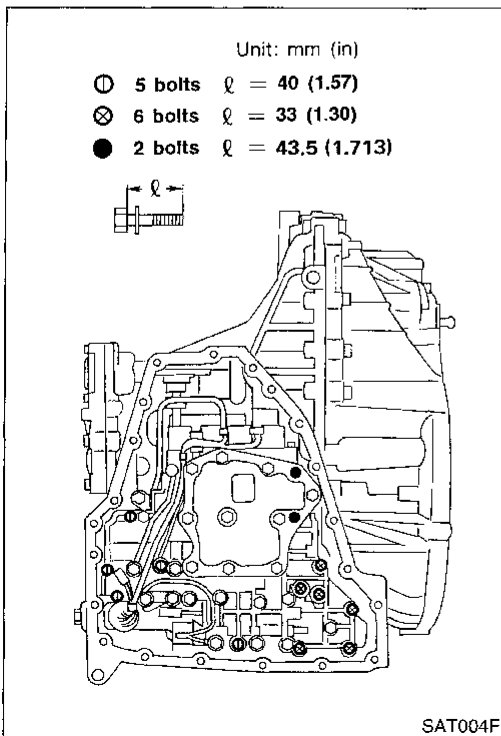

6. Remove control valve assembly by removing fixing bolts ①, ⊗ and ●.

Bolt length, number and location are shown in the illustration.

- **Be careful not to drop manual valve and servo release accumulator return spring.**

7. Disassemble and inspect control valve assembly if necessary. Refer to AT-235.

ON-VEHICLE SERVICE

Control Valve Assembly and Accumulator (Cont'd)

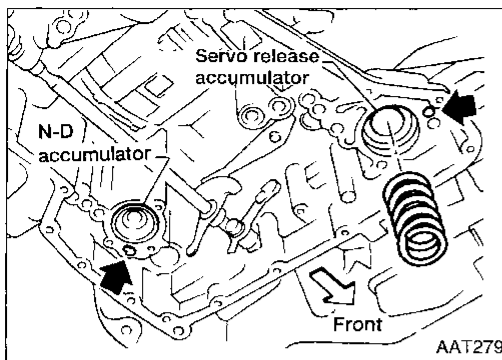

8. Remove servo release and N-D accumulators by applying compressed air if necessary.
 - Hold each piston with a rag.

GI

MA

EM

LC

INSTALLATION

- Set manual shaft in Neutral, then align manual plate with groove in manual valve.
- After installing control valve assembly, make sure that selector lever can be moved to all positions.

EC

FE

CL

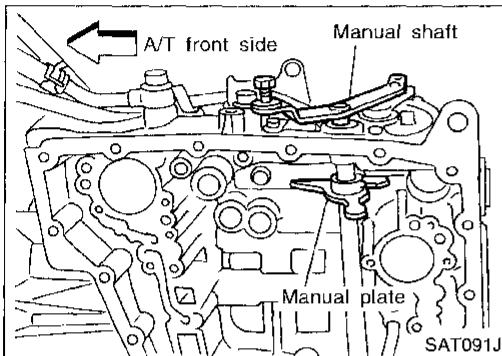

MT

Revolution Sensor Replacement

1. Remove under cover.
2. Remove revolution sensor from A/T.
3. Reinstall any part removed.
 - Always use new sealing parts.

AT

FA

RA

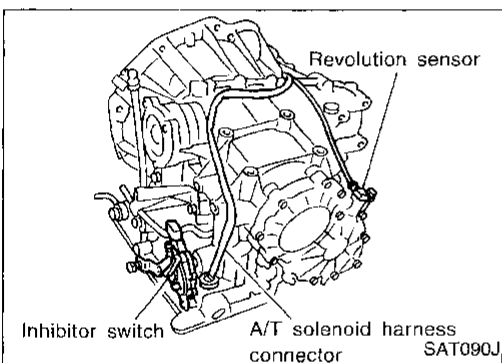

BR

Inhibitor Switch Adjustment

1. Remove control cable from manual shaft.
2. Set manual shaft in "N" position.
3. Loosen inhibitor switch fixing bolts.

ST

RS

BT

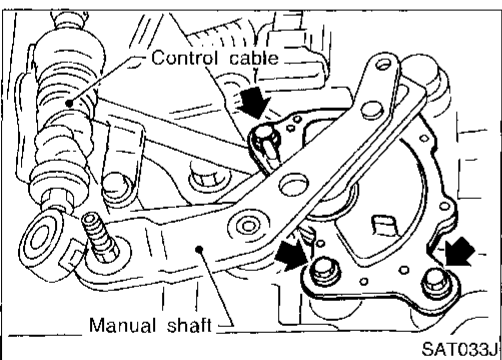

HA

4. Insert pin into adjustment holes in both inhibitor switch and manual shaft as near vertical as possible.
5. Reinstall any part removed.
6. Check continuity of inhibitor switch. Refer to AT-80.

EL

IDX

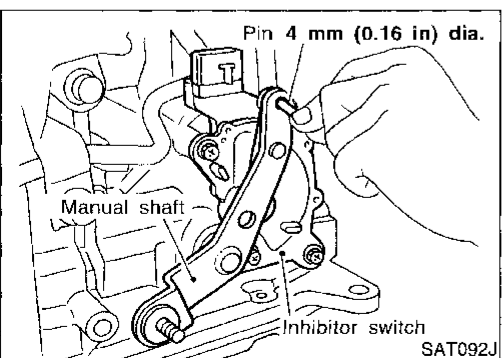

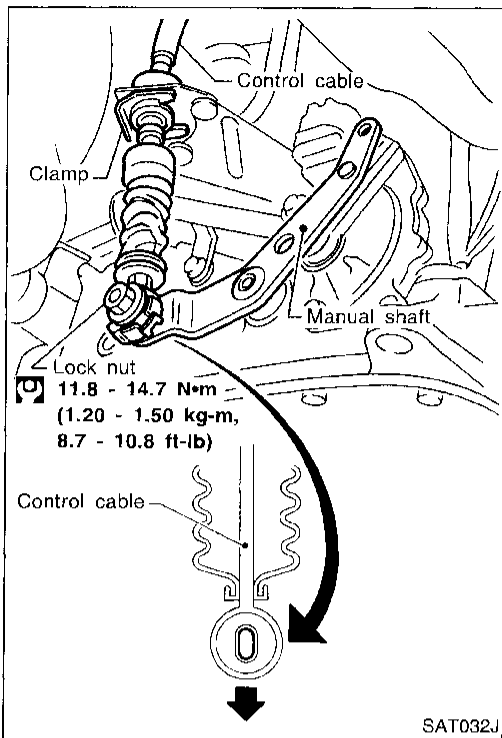

Control Cable Adjustment

Move selector lever from the "P" position to the "1" position. You should be able to feel the detents in each position. If the detents cannot be felt or the pointer indicating the position is improperly aligned, the control cable needs adjustment.

1. Place selector lever in "P" position.
2. Loosen control cable lock nut and place manual shaft in "P" position.

CAUTION:

Turn wheels more than 1/4 rotations and apply the park lock.

3. Pull control cable in the direction of the arrow shown in the illustration by specified force.

Specified force: 9.8 N (1.0 kg, 2.2 lb)

4. Tighten control cable lock nut.
5. Move selector lever from "P" to "1" position again. Make sure that selector lever moves smoothly.

- Make sure that the starter operates when the selector lever is placed in the "N" or "P" position.
- Make sure that the transmission is locked properly when the selector lever is placed in the "P" position.

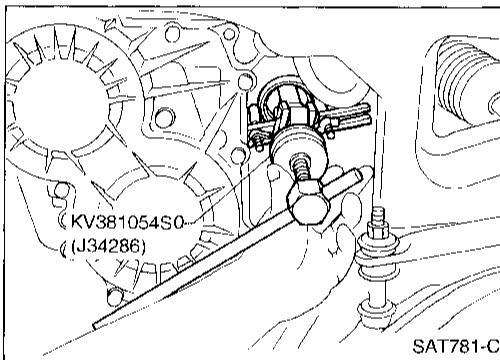

Differential Side Oil Seal Replacement

1. Remove drive shaft assembly. Refer to FA section ("Removal", "FRONT AXLE — Drive Shaft").
2. Remove oil seal.

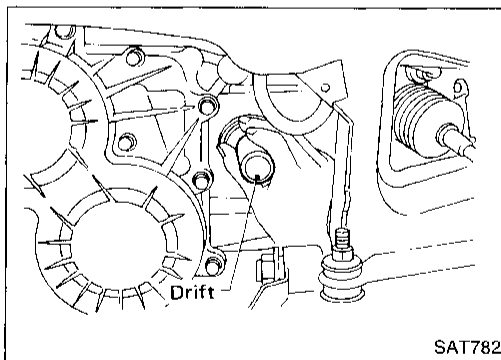

3. Install oil seal.
 - Apply ATF before installing.
4. Reinstall any part removed.

REMOVAL AND INSTALLATION

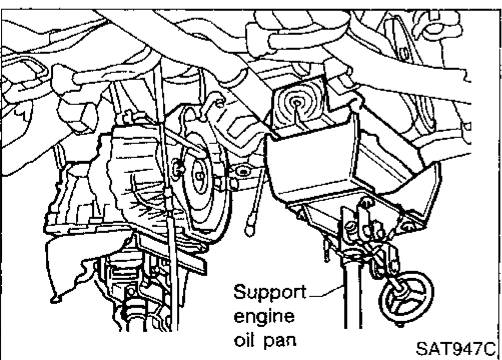
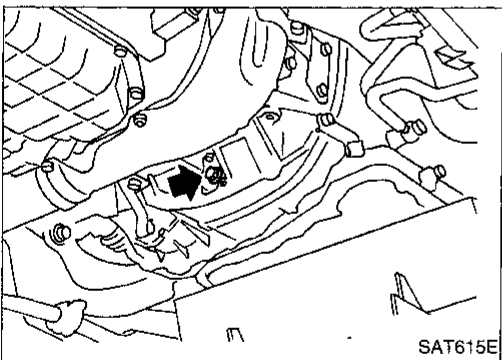
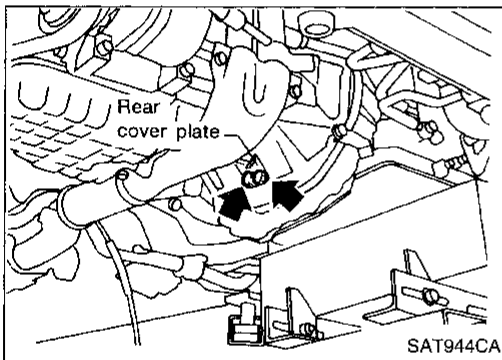
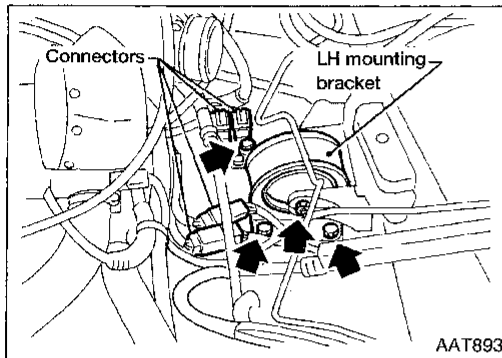
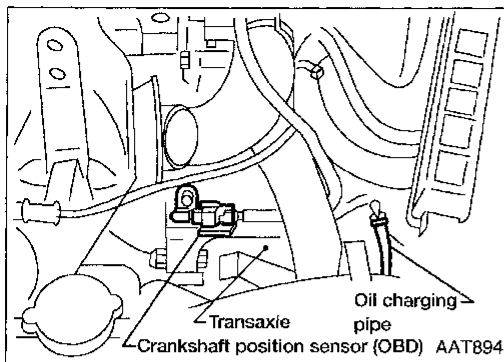

Removal

CAUTION:

When removing the transaxle assembly from engine, first remove the crankshaft position sensor (OBD) from the assembly.

Be careful not to damage sensor edge.

1. Remove battery and bracket.
2. Remove air cleaner and resonator.
3. Disconnect terminal cord assembly harness connector and inhibitor switch harness connectors.
4. Disconnect harness connectors of revolution sensor, ground and vehicle speed sensor.
5. Remove crankshaft position sensor (OBD) from transaxle.
6. Remove LH mounting bracket from transaxle and body. Tighten LH mounting bracket bolts to the specified torque. Refer to EM section ("ENGINE REMOVAL").
7. Disconnect control cable at transaxle side.
8. Drain ATF.
9. Remove drive shafts. Refer to FA section ("Removal", "FRONT AXLE — Drive Shaft").
10. Disconnect oil cooler piping.
11. Remove starter motor from transaxle.
12. Support engine by placing a jack under oil pan.
 - **Do not place jack under oil pan drain plug.**
13. Remove center member. Tighten center member bolts to the specified torque. Refer to EM section ("ENGINE REMOVAL").
14. Remove rear cover plate and bolts securing torque converter to drive plate. Tighten rear plate cover bolts to the specified torque. Refer to EM section ("OIL PAN").
 - **Rotate crankshaft for access to securing bolts.**
15. Support transaxle with a jack.
16. Remove bolts fixing A/T to engine.
17. Lower transaxle while supporting it with a jack.

REMOVAL AND INSTALLATION

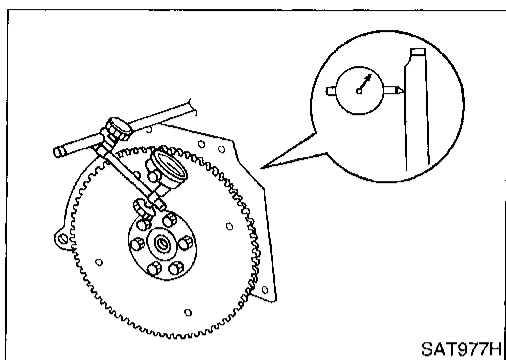

Installation

- Drive plate runout

CAUTION:

Do not allow any magnetic materials to contact the ring gear teeth.

Maximum allowable runout:

Refer to EM section (“Inspection”, “CYLINDER BLOCK”).

If this runout is out of allowance, replace drive plate and ring gear.

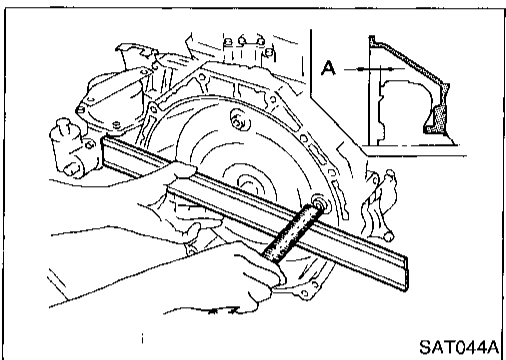

- When connecting torque converter to transaxle, measure distance “A” to be certain that they are correctly assembled.

Distance “A”:

19 mm (0.75 in) or more

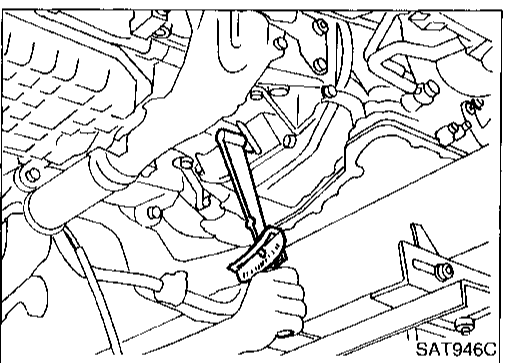

- Install bolts fixing converter to drive plate.
- **With converter installed, rotate crankshaft several turns to check that transaxle rotates freely without binding.**

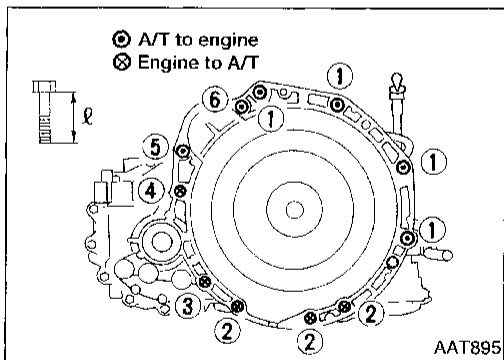

- Tighten bolts securing transaxle.
- Tighten LH mounting bracket bolts to the specified torque. Refer to EM section (“ENGINE REMOVAL”).
- Tighten center member bolts to the specified torque. Refer to EM section (“ENGINE REMOVAL”).
- Tighten rear plate cover bolts to the specified torque. Refer to EM section (“OIL PAN”).

Bolt No.	Tightening torque N·m (kg·m, ft·lb)	ℓ mm (in)
①	39 - 49 (4.0 - 5.0, 29 - 36)	45 (1.77)
②	30 - 36 (3.1 - 3.7, 22 - 27)	30 (1.18)
③	30 - 36 (3.1 - 3.7, 22 - 27)	40 (1.57)
④	74 - 83 (7.5 - 8.5, 54 - 61)	45 (1.77)
⑤	30 - 36 (3.1 - 3.7, 22 - 27)	80 (3.15)
⑥	30 - 36 (3.1 - 3.7, 22 - 27)	65 (2.56)

- Reinstall any part removed.

REMOVAL AND INSTALLATION

Installation (Cont'd)

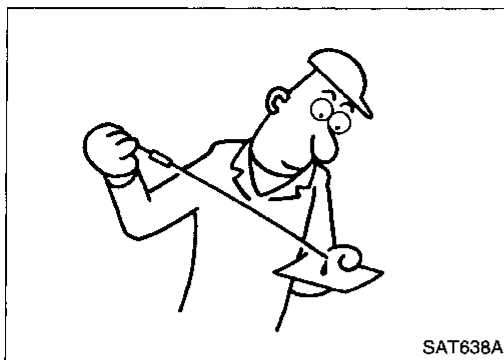

- Check fluid level in transaxle.
- Move selector lever through all positions to be sure that transaxle operates correctly.
With parking brake applied, rotate engine at idling. Move selector lever through "N" to "D", to "2", to "1" and to "R" position. A slight shock should be felt by hand gripping selector each time transaxle is shifted.
- Perform road test. Refer to AT-56.

GI

MA

EM

LC

EC

FE

CL

MT

AT

FA

RA

BR

ST

RS

BT

HA

EL

IDX

MAJOR OVERHAUL

SEC. 311•313•327•381

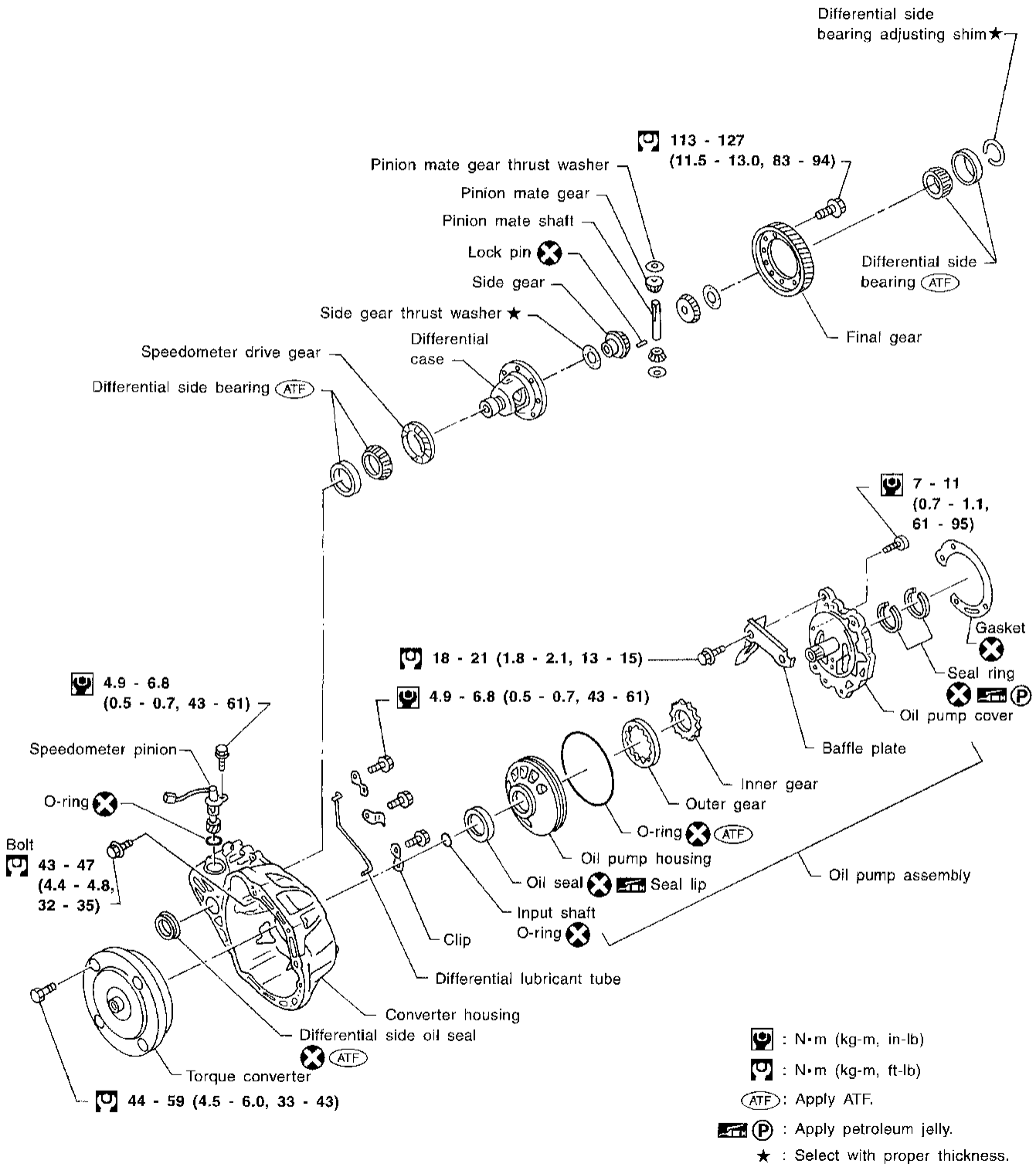

SEC. 310-315-317-319

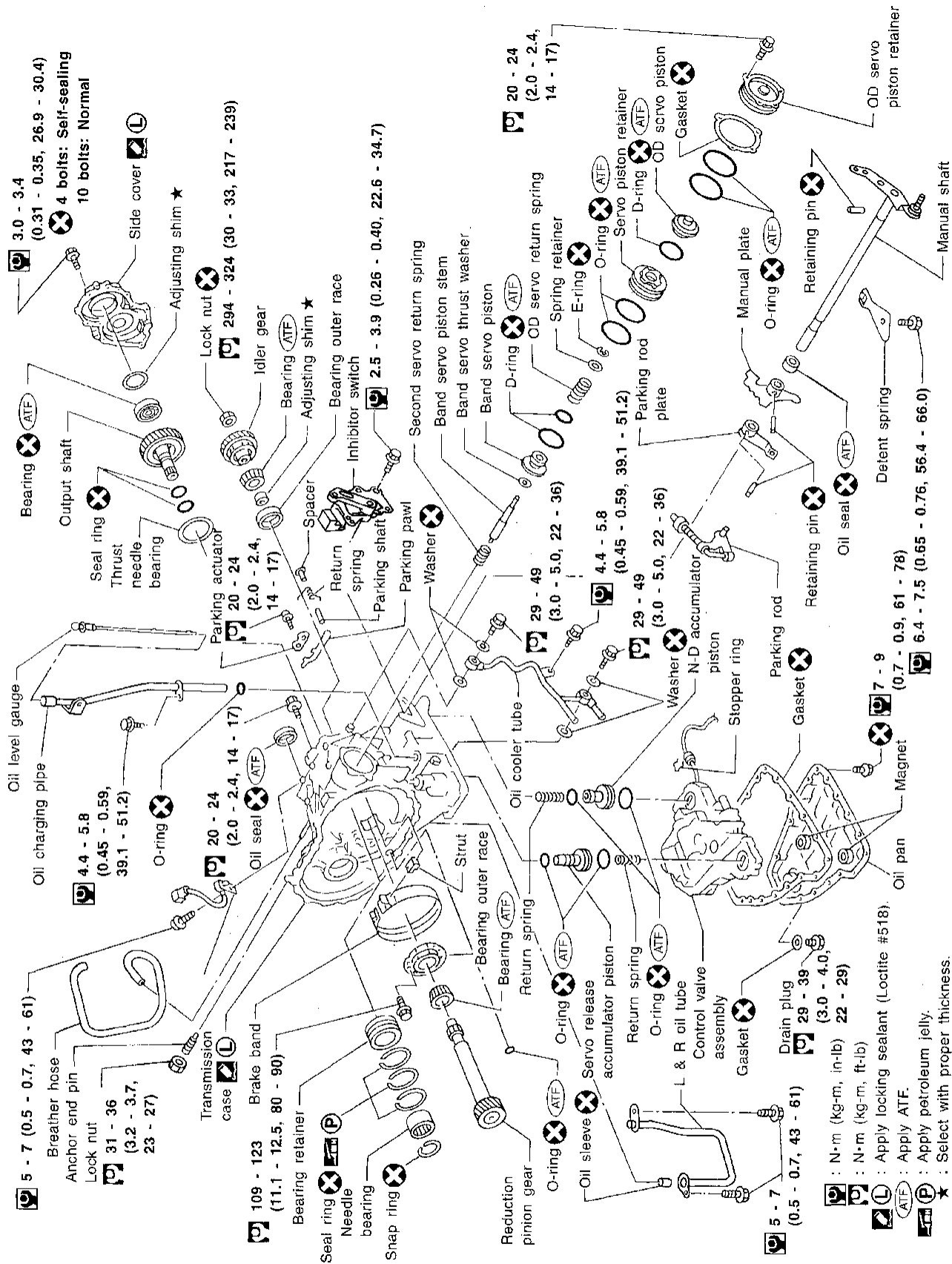

MAJOR OVERHAUL

Locations of Adjusting Shims, Needle Bearings, Thrust Washers and Snap Rings

Outer diameter of thrust washers

Item number	Outer diameter mm (in)
J ★	76.0 (2.992)
K ★	80.0 (3.150)

★ : Select proper thickness

Outer and inner diameter of needle bearings

Item number	Outer diameter mm (in)	Inner diameter mm (in)
A	49.8 (1.961)	35.2 (1.386)
B	41.8 (1.646)	23.1 (0.909)
C	70.0 (2.756)	50.0 (1.969)
D	50.9 (2.004)	31.2 (1.228)
E	51.0 (2.008)	33.1 (1.303)
F	49.8 (1.961)	35.2 (1.386)
G	56.5 (2.224)	34.9 (1.374)
H	87.0 (3.425)	69.0 (2.717)
I	50.6 (1.992)	34.7 (1.366)

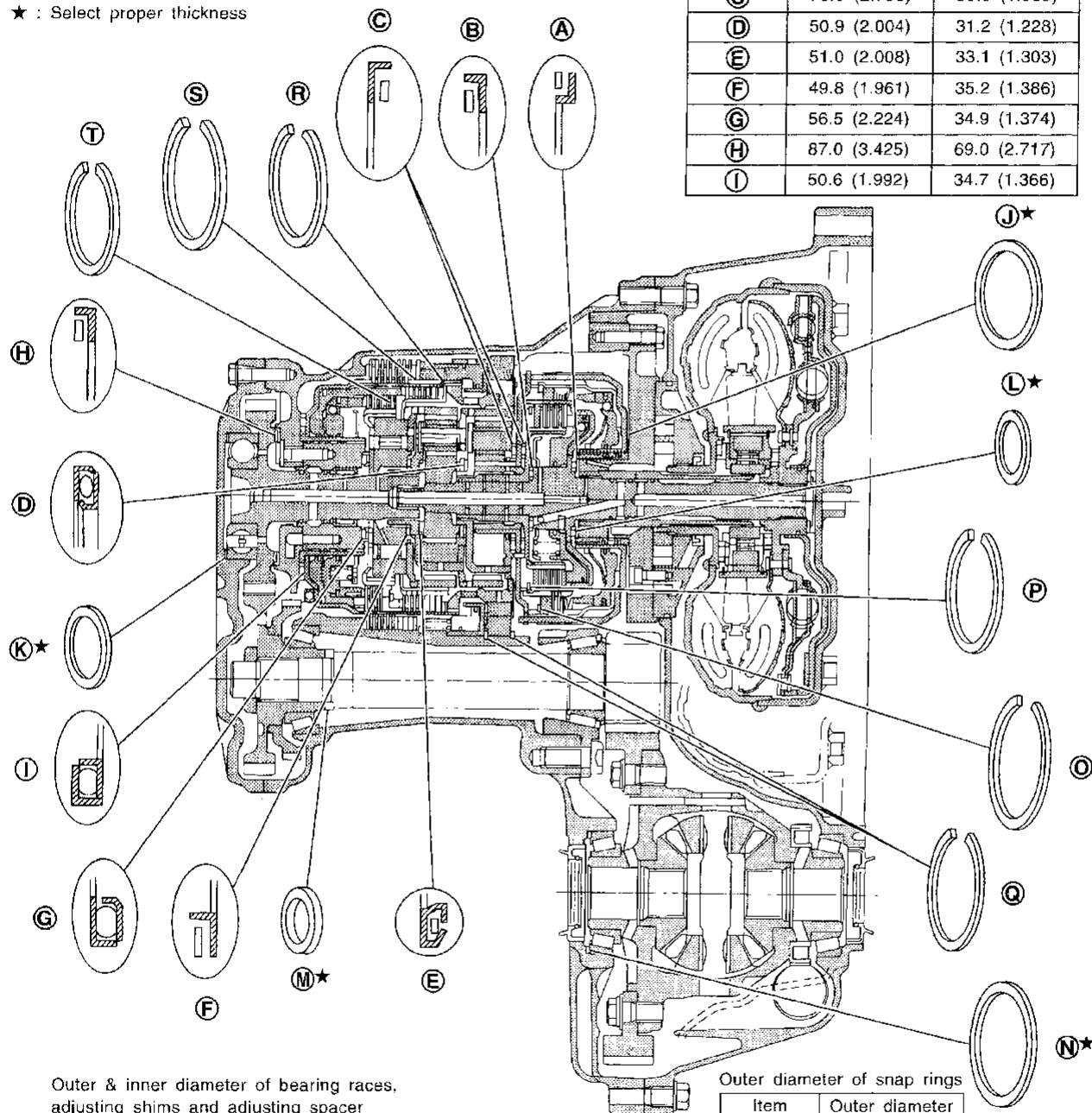

Outer & inner diameter of bearing races, adjusting shims and adjusting spacer

Item number	Outer diameter mm (in)	Inner diameter mm (in)
L ★	51.0 (2.008)	36.0 (1.417)
M ★	38.0 (1.496)	28.1 (1.106)
N ★	75.0 (2.953)	68.0 (2.677)
	98.0 (3.858)	91.0 (3.583)

★ : Select proper thickness

Outer diameter of snap rings

Item number	Outer diameter mm (in)
O	150 (5.91)
P	119.1 (4.689)
Q	182.8 (7.197)
R	144.8 (5.701)
S	173.8 (6.843)
T	133.9 (5.272)

GI

MA

EM

LC

EC

FE

CL

MT

AT

FA

RA

BR

ST

RS

BT

HA

EL

IDX

MAJOR OVERHAUL

Oil Channel

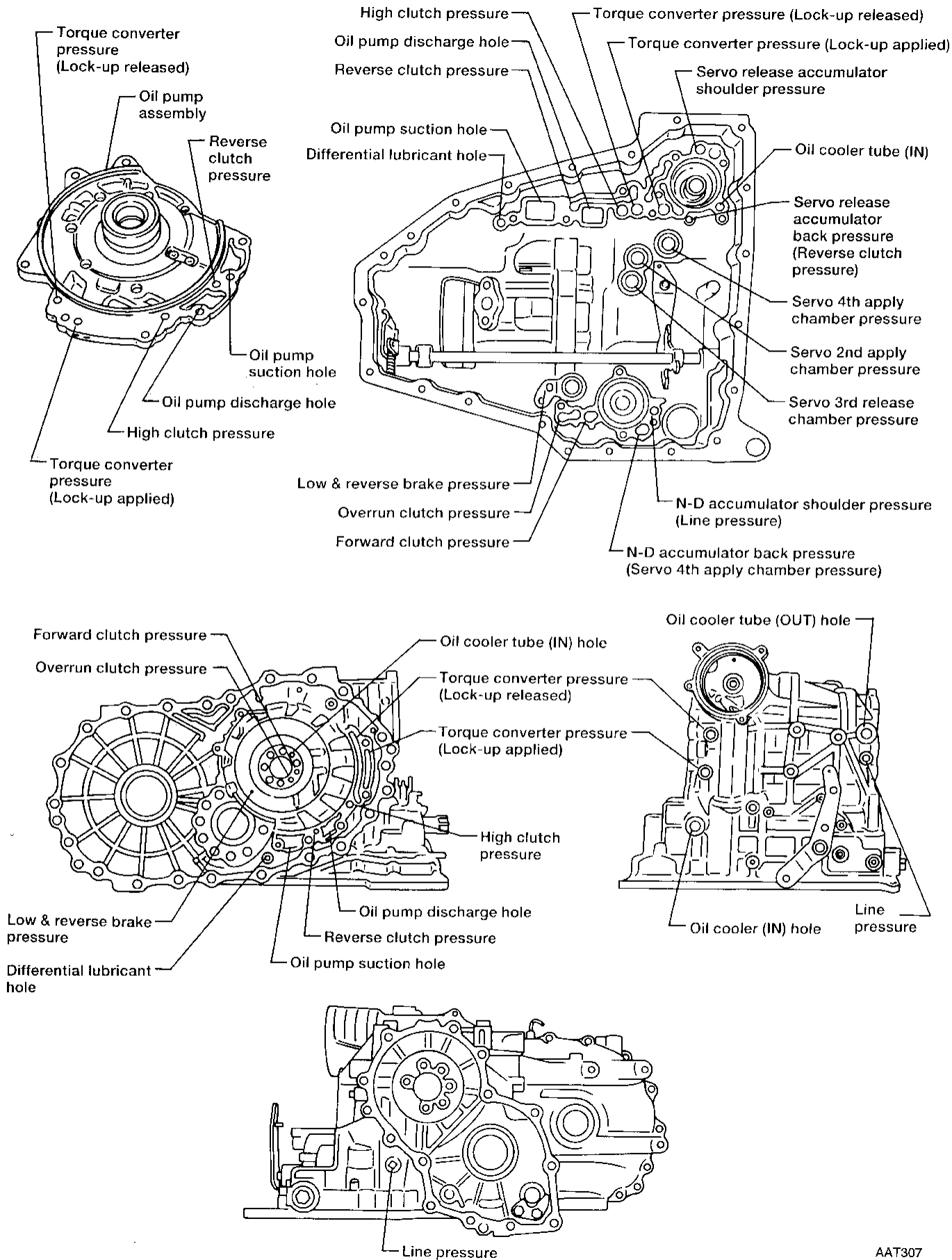

DISASSEMBLY

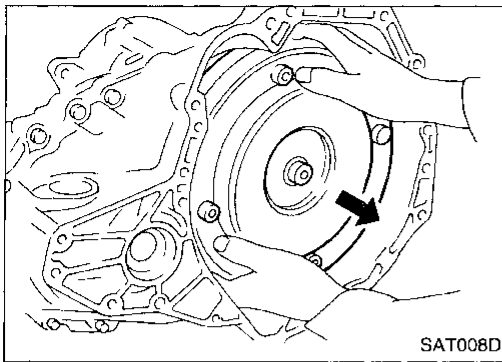

1. Drain ATF through drain plug.
2. Remove torque converter.

GI

MA

EM

LC

EC

FE

CL

MT

AT

FA

RA

BR

ST

RS

BT

HA

EL

IDX

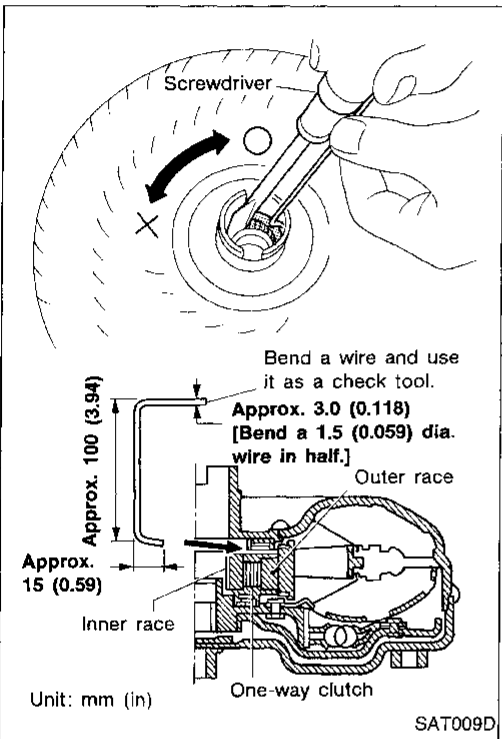

3. Check torque converter one-way clutch using check tool as shown at left.
 - a. Insert check tool into the groove of bearing support built into one-way clutch outer race.
 - b. When fixing bearing support with check tool, rotate one-way clutch spline using screwdriver.
 - c. Check that inner race rotates clockwise only. If not, replace torque converter assembly.

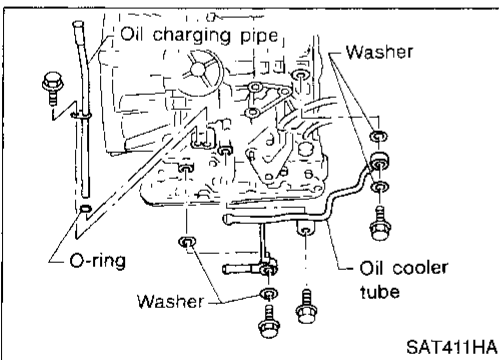

4. Remove oil charging pipe and oil cooler tube.

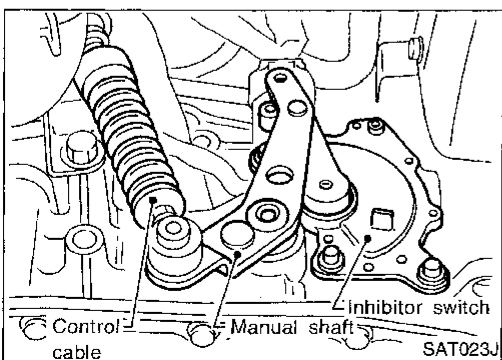

5. Set manual shaft to position "P".
6. Remove inhibitor switch.

DISASSEMBLY

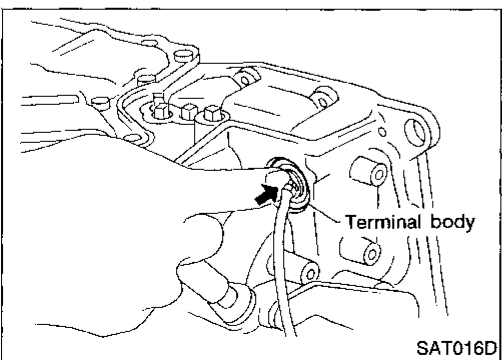
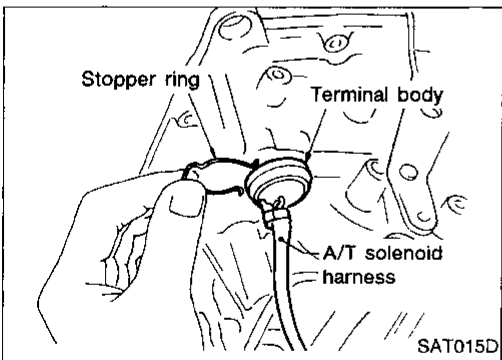
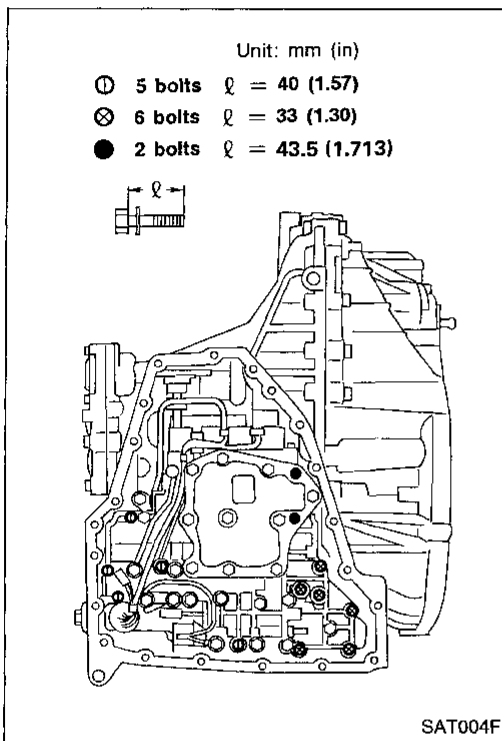
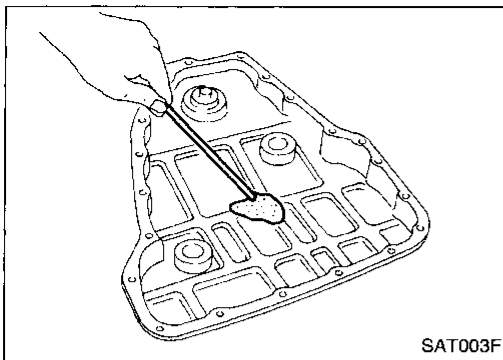

7. Remove oil pan and oil pan gasket.
 - **Do not reuse oil pan bolts.**
8. Check foreign materials in oil pan to help determine causes of malfunction. If the fluid is very dark, smells burned, or contains foreign particles, the frictional material (clutches, band) may need replacement. A tacky film that will not wipe clean indicates varnish build up. Varnish can cause valves, servo, and clutches to stick and can inhibit pump pressure.
 - **If frictional material is detected, replace radiator after repair of A/T. Refer to LC section ("Radiator", "ENGINE COOLING SYSTEM").**
9. Remove control valve assembly according to the following procedures.
 - a. Remove control valve assembly mounting bolts ①, ⊗ and ●.
 - b. Remove stopper ring from terminal body.
 - c. Push terminal body into transmission case and draw out solenoid harness.

DISASSEMBLY

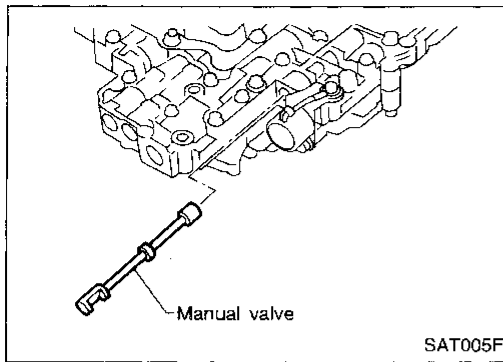

10. Remove manual valve from control valve assembly.

GI

MA

EM

LG

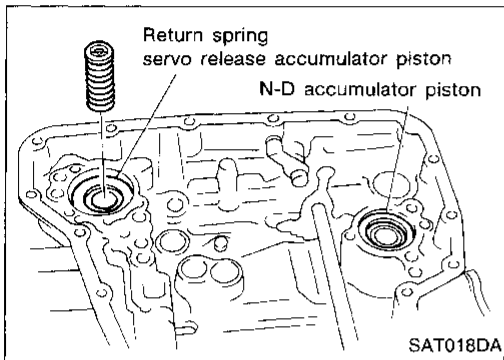

11. Remove return spring from servo release accumulator piston.

EC

FE

CL

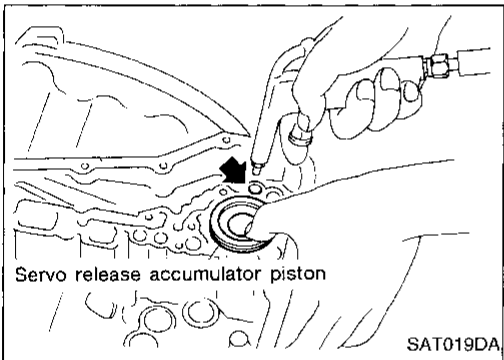

12. Remove servo release accumulator piston with compressed air.

13. Remove O-rings from servo release accumulator piston.

MT

AT

FA

RA

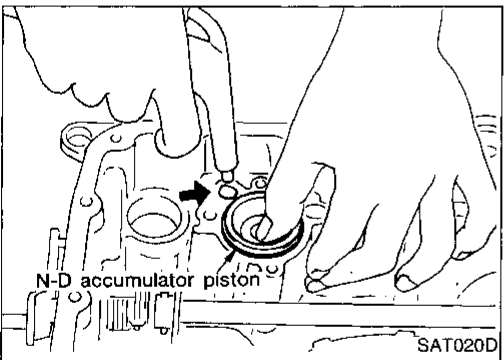

14. Remove N-D accumulator piston and return spring with compressed air.

15. Remove O-rings from N-D accumulator piston.

BR

ST

RS

BT

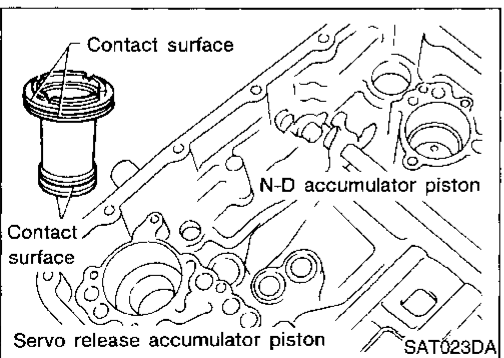

16. Check accumulator pistons and contact surface of transmission case for damage.

17. Check accumulator return springs for damage and free length.

HA

EL

IDX

DISASSEMBLY

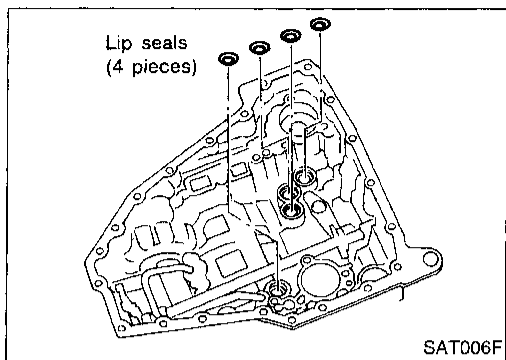

18. Remove lip seals.

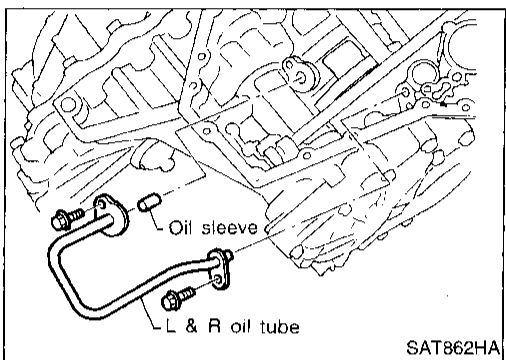

19. Remove L & R oil tube and oil sleeve.

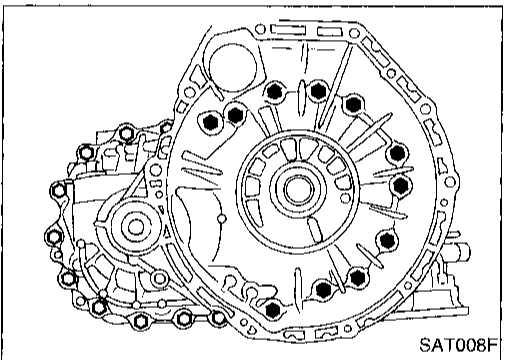

20. Remove converter housing according to the following procedures.

- a. Remove converter housing mounting bolts.
- b. Remove converter housing by tapping it lightly.

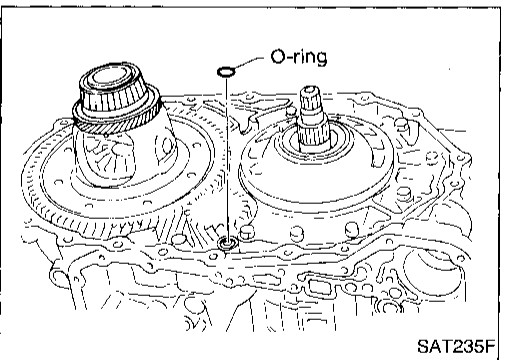

c. Remove O-ring from differential oil port.

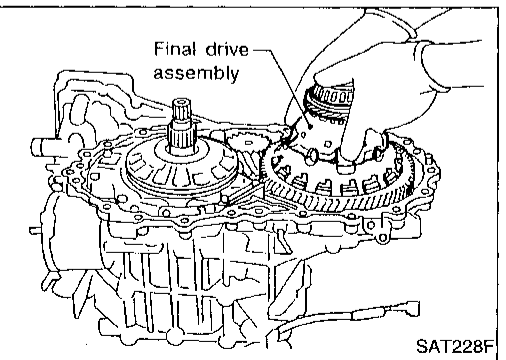

21. Remove final drive assembly from transmission case.

DISASSEMBLY

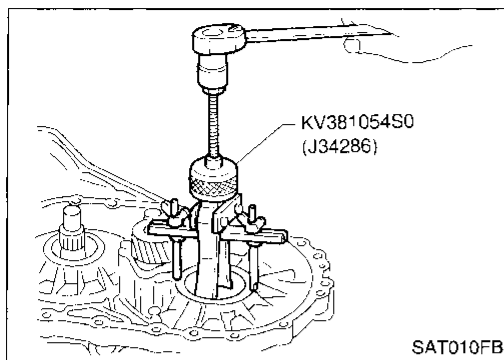

22. Remove differential side bearing outer race from transmission case.

CI

MA

EM

LC

EC

FE

CL

MT

AT

FA

RA

BR

ST

RS

ET

HA

EL

IDX

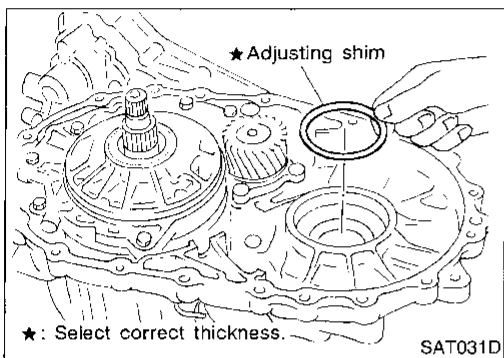

23. Remove differential side bearing adjusting shim from transmission case.

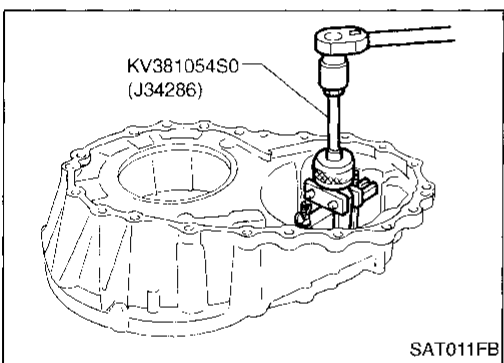

24. Remove differential side bearing outer race from converter housing.

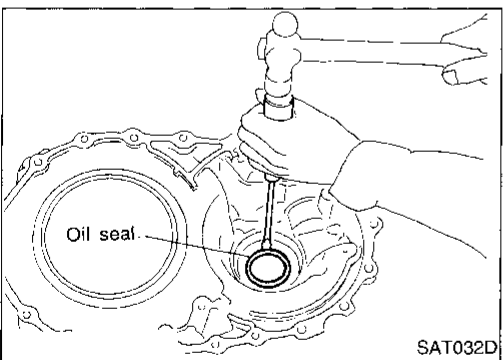

25. Remove oil seal with screwdriver from converter housing.
● Be careful not to damage case.

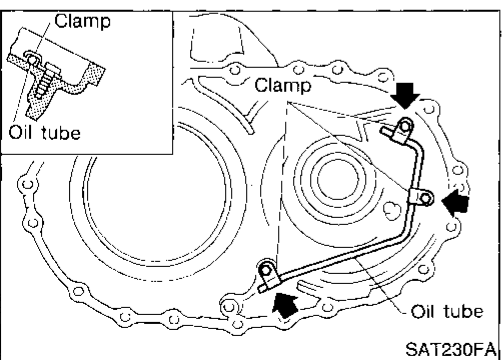

26. Remove oil tube from converter housing.

DISASSEMBLY

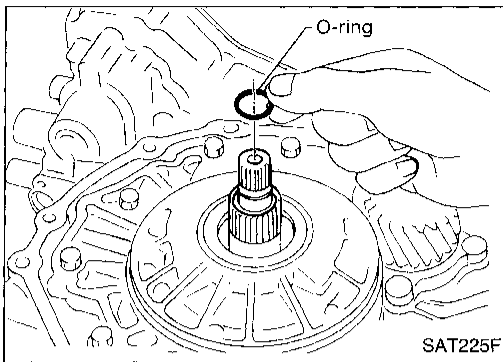

27. Remove oil pump according to the following procedures.
- Remove O-ring from input shaft.

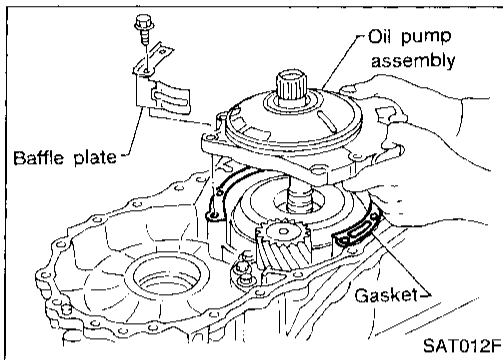

- Remove oil pump assembly, baffle plate and gasket from transmission case.

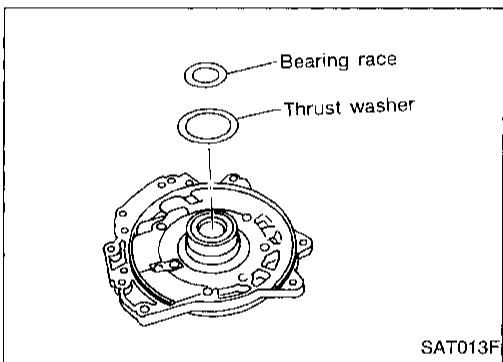

- Remove thrust washer and bearing race from oil pump assembly.

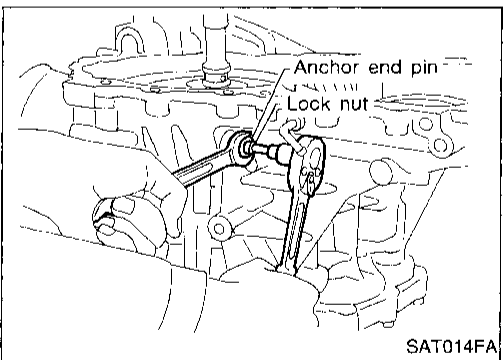

28. Remove brake band according to the following procedures.
- Loosen lock nut, then back off anchor end pin.
 - Do not reuse anchor end pin.**

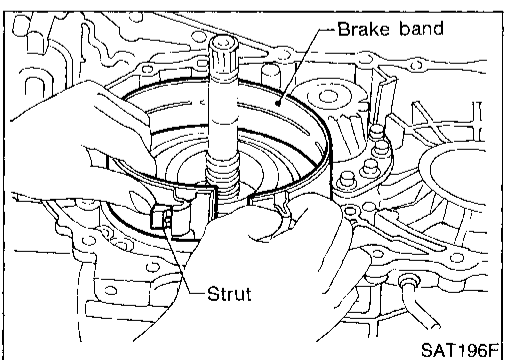

- Remove brake band and strut from transmission case.

DISASSEMBLY

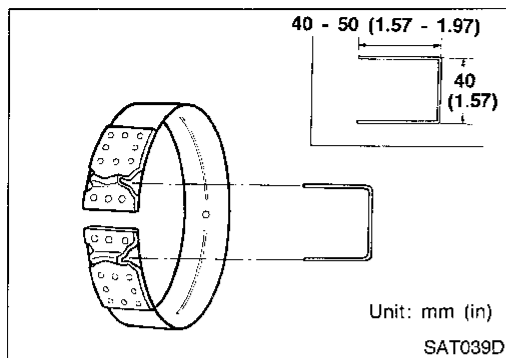

- To prevent brake linings from cracking or peeling, do not stretch the flexible band unnecessarily. When removing the brake band, always secure it with a clip as shown in the figure at left. Leave the clip in position after removing the brake band.

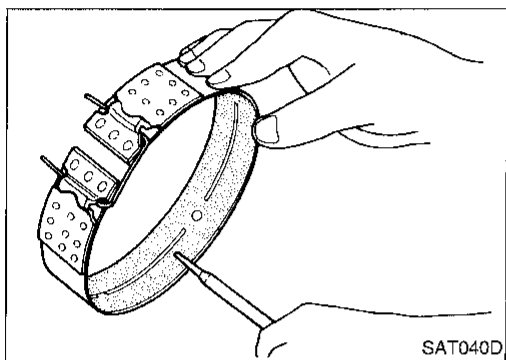

- Check brake band facing for damage, cracks, wear or burns.

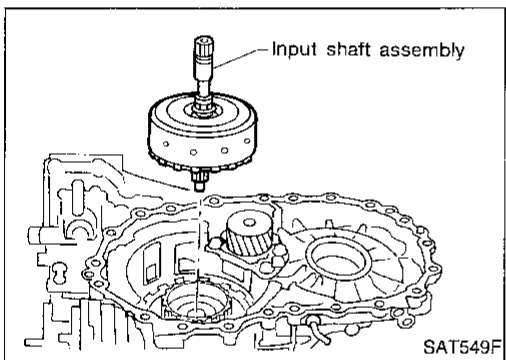

- Remove input shaft assembly (high clutch) and reverse clutch according to the following procedures.

- Remove input shaft assembly (high clutch) with reverse clutch.

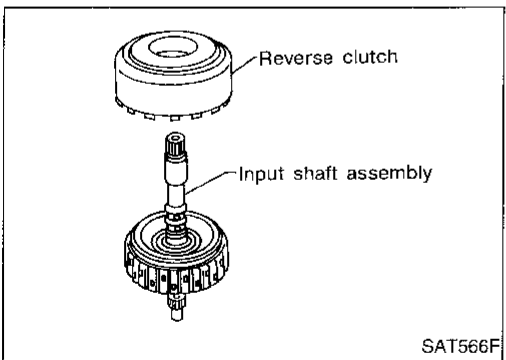

- Remove input shaft assembly (high clutch) from reverse clutch.

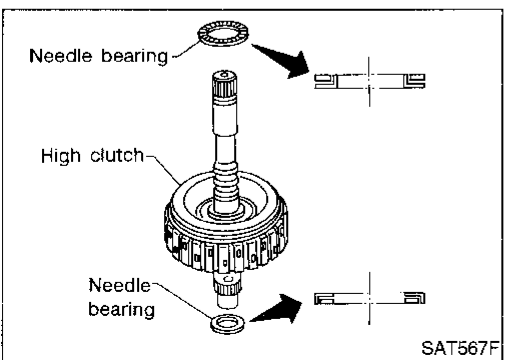

- Remove needle bearings from high clutch drum and check for damage or wear.

GI
MA
EM
LC
EC
FE
CL
MT
AT
FA
RA
BR
ST
RS
BT
HA
EL
IDX

DISASSEMBLY

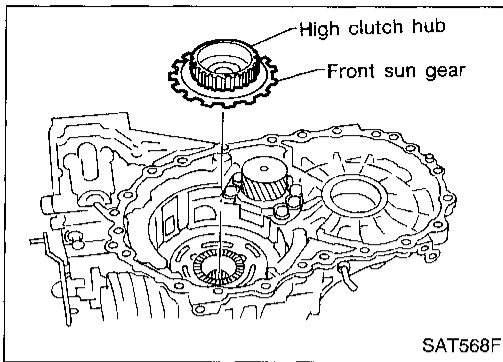

- d. Remove high clutch hub and front sun gear from transmission case.

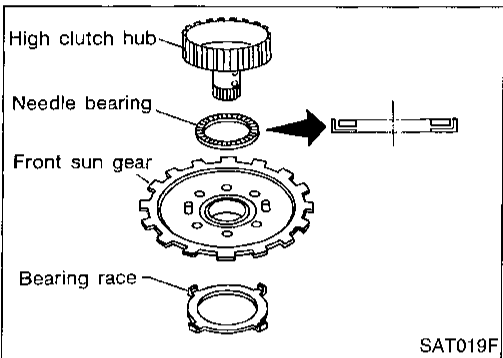

- e. Remove front sun gear and needle bearing from high clutch hub and check for damage or wear.
f. Remove bearing race from front sun gear and check for damage or wear.

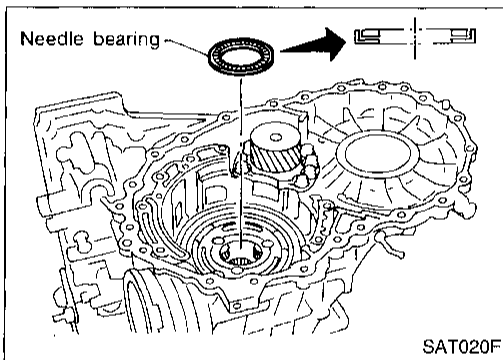

30. Remove needle bearing from transmission case and check for damage or wear.

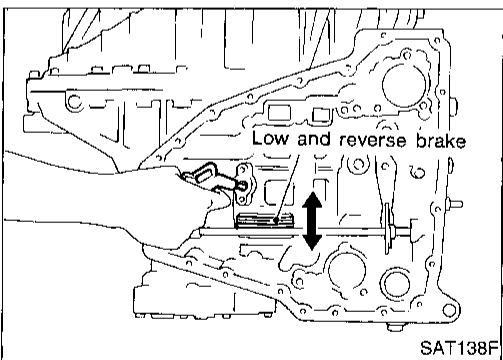

31. Apply compressed air and check to see that low and reverse brake operates.

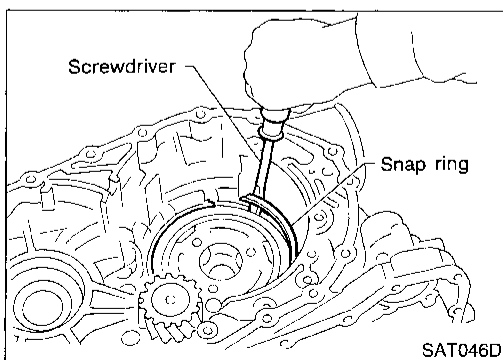

32. Remove low one-way clutch and front planetary carrier assembly according to the following procedures.
a. Remove snap ring with flat-bladed screwdriver.

DISASSEMBLY

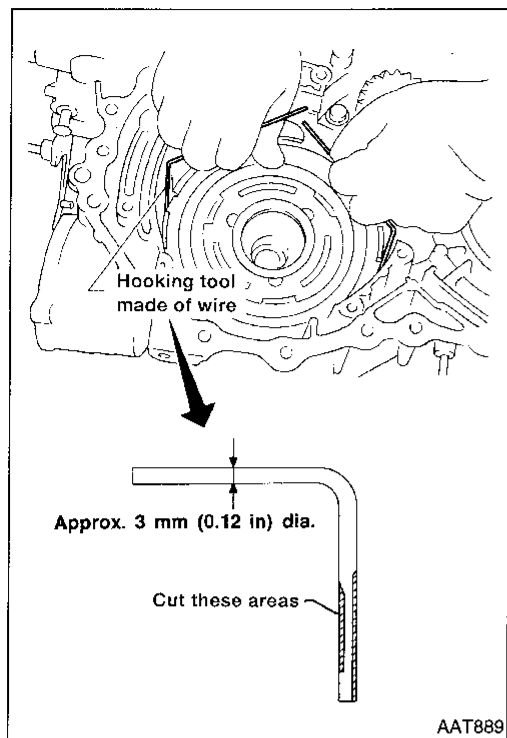

b. Remove low one-way clutch with a hook made of wire.

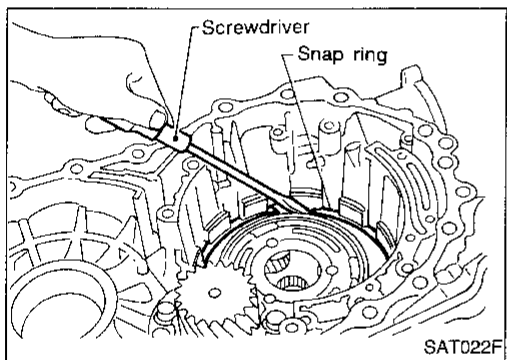

c. Remove snap ring with flat-bladed screwdriver.

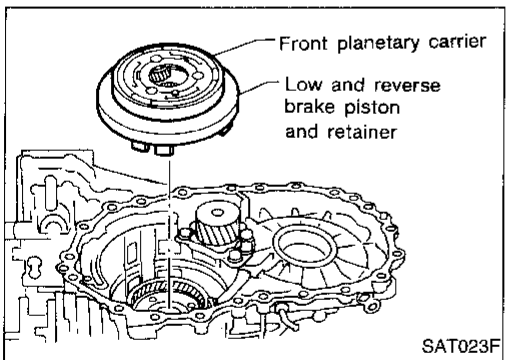

d. Remove front planetary carrier with low and reverse brake piston and retainer.

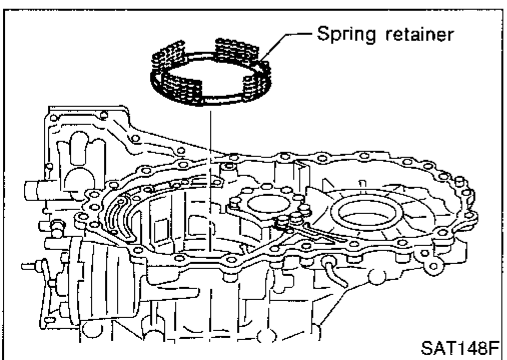

e. Remove low and reverse brake spring retainer.
• Do not remove return springs from spring retainer.

GI

MA

EM

LC

EC

FE

CL

MT

AT

FA

RA

BR

ST

RS

BT

HA

EL

IDX

DISASSEMBLY

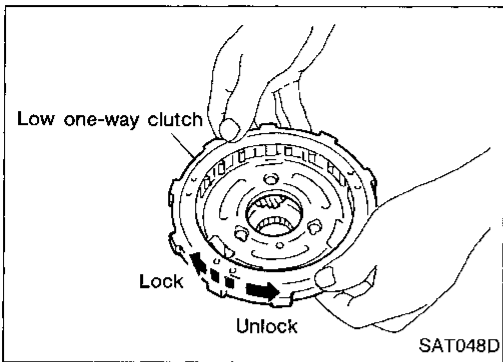

- f. Check that low one-way clutch rotates in the direction of the arrow and locks in the opposite direction.

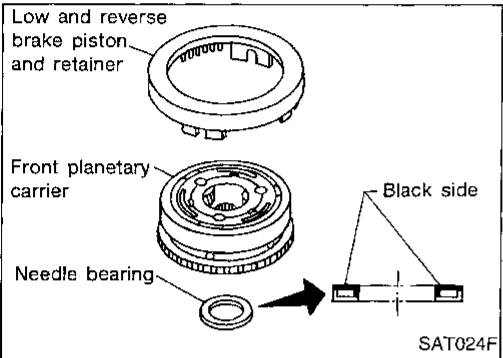

- g. Remove needle bearing, low and reverse brake piston and retainer from front planetary carrier.

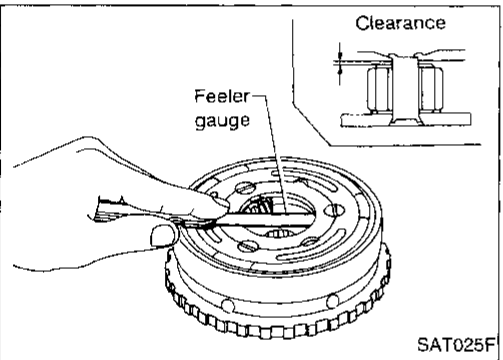

- h. Check front planetary carrier, low one-way clutch and needle bearing for damage or wear.
- i. Check clearance between planetary gears and planetary carrier with feeler gauge.

Standard clearance:

0.20 - 0.70 mm (0.0079 - 0.0276 in)

Allowable limit:

0.80 mm (0.0315 in)

Replace front planetary carrier if the clearance exceeds allowable limit.

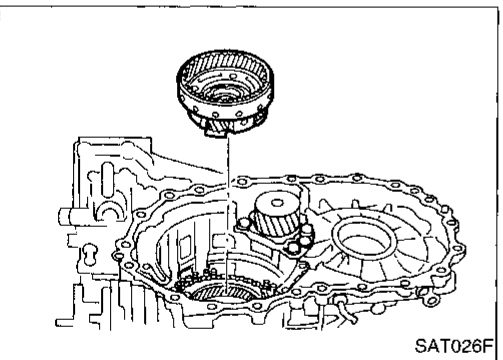

33. Remove rear planetary carrier assembly and rear sun gear according to the following procedures.

- a. Remove rear planetary carrier assembly from transmission case.

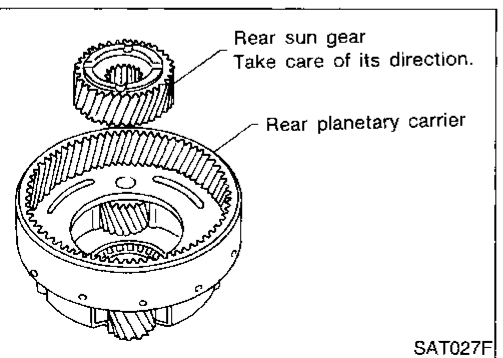

- b. Remove rear sun gear from rear planetary carrier.

DISASSEMBLY

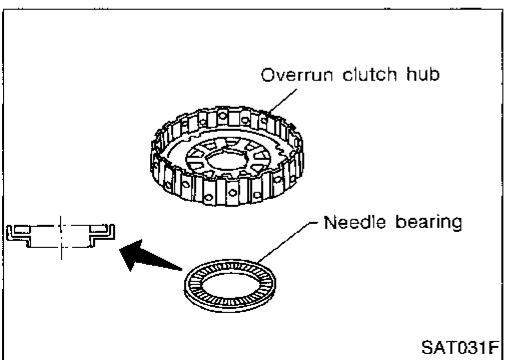
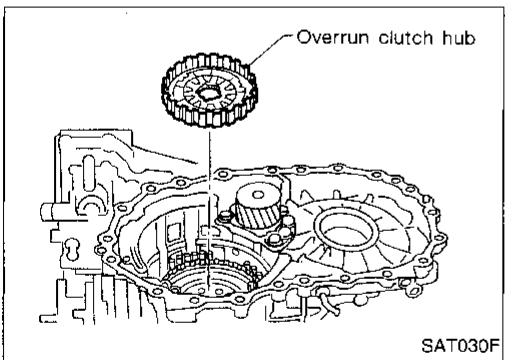
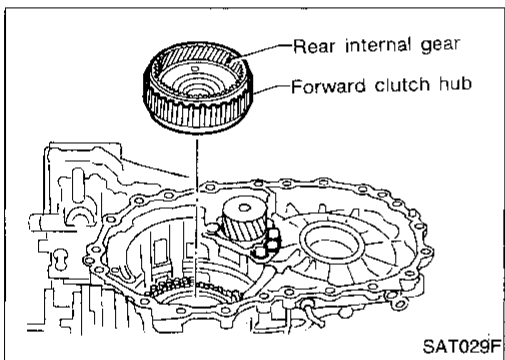
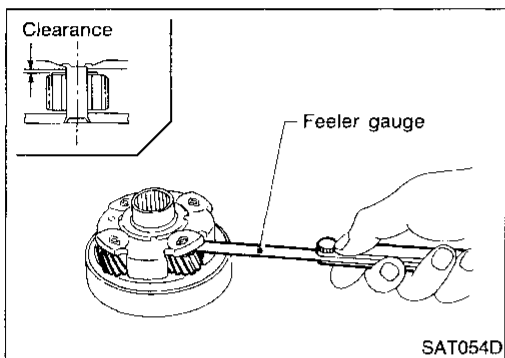
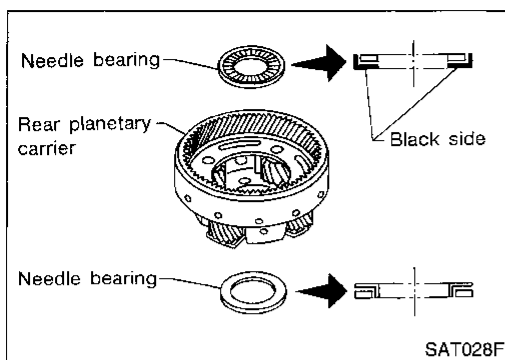

c. Remove needle bearings from rear planetary carrier assembly.

d. Check rear planetary carrier, rear sun gear and needle bearings for damage or wear.

e. Check clearance between pinion washer and rear planetary carrier with feeler gauge.

Standard clearance:

0.20 - 0.70 mm (0.0079 - 0.0276 in)

Allowable limit:

0.80 mm (0.0315 in)

Replace rear planetary carrier if the clearance exceeds allowable limit.

34. Remove rear internal gear and forward clutch hub from transmission case.

35. Remove overrun clutch hub from transmission case.

36. Remove needle bearing from overrun clutch hub and check for damage or wear.

GI

MA

EM

LC

EC

FE

CL

MT

AT

FA

RA

BR

ST

RS

BT

HA

EL

IDX

DISASSEMBLY

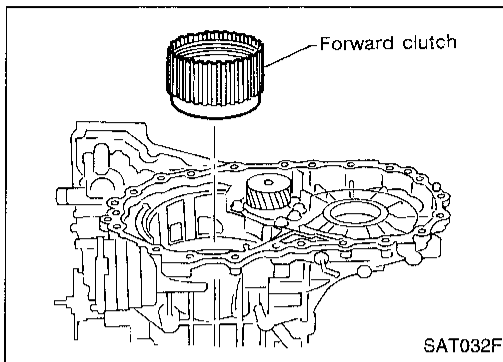

37. Remove forward clutch assembly from transmission case.

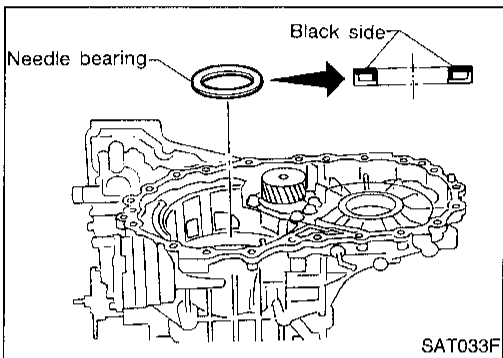

38. Remove needle bearing from transmission case.

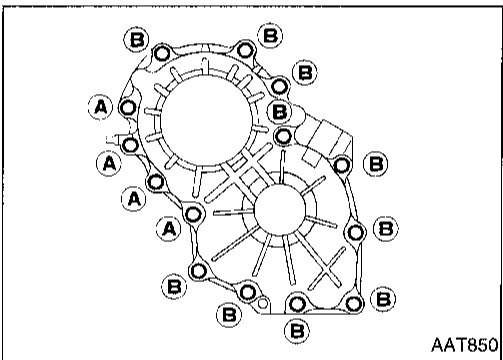

39. Remove output shaft assembly according to the following procedures.

a. Remove side cover bolts.

- Do not mix bolts (A) and (B).
- Always replace bolts (A) as they are self-sealing bolts.

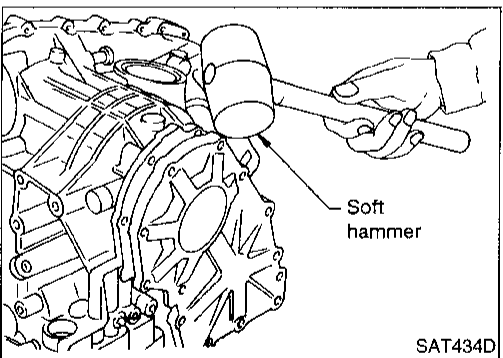

b. Remove side cover by lightly tapping it with a soft hammer.

- Be careful not to drop output shaft assembly. It might come out when removing side cover.

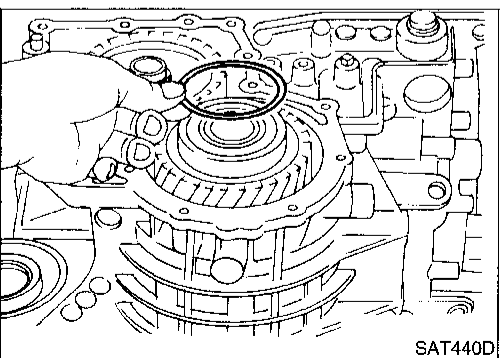

c. Remove adjusting shim.

DISASSEMBLY

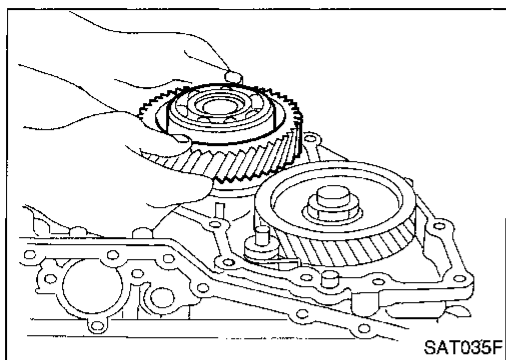

d. Remove output shaft assembly.

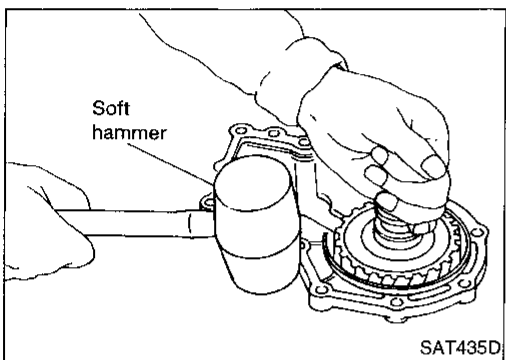

- If output shaft assembly came off with side cover, tap cover with a soft hammer to separate.

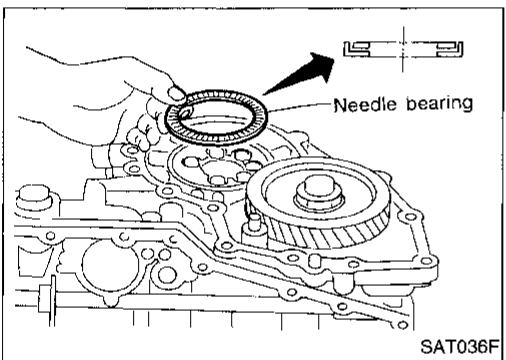

e. Remove needle bearing.

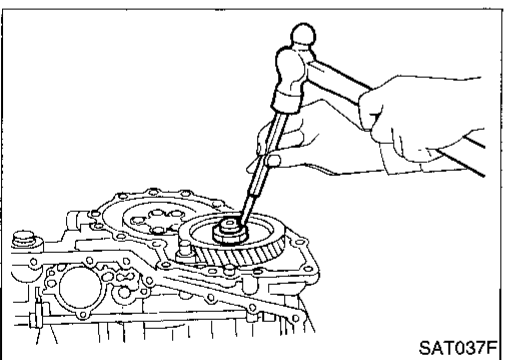

40. Disassemble reduction pinion gear according to the following procedures.

- a. Set manual shaft to position "P" to fix idler gear.
- b. Unlock idler gear lock nut using a pin punch.

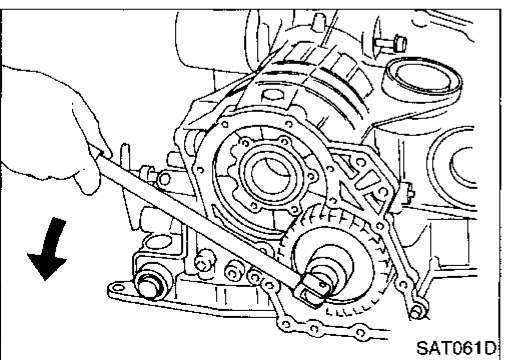

- c. Remove idler gear lock nut.
- Do not reuse idler gear lock nut.

GI

MA

EM

LC

EC

FE

CL

MT

AT

FA

RA

BR

ST

RS

BT

HA

EL

IDX

DISASSEMBLY

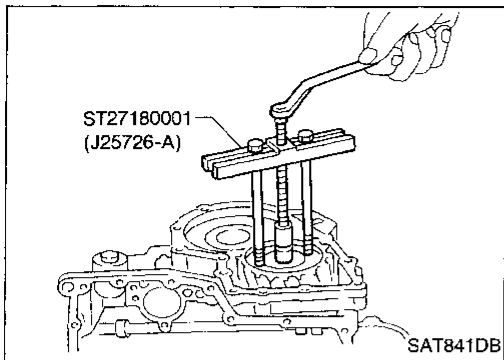

d. Remove idler gear with puller.

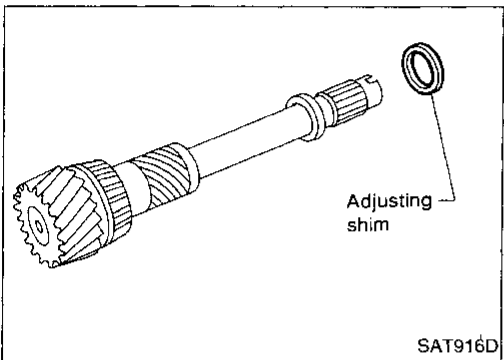

e. Remove reduction pinion gear.

f. Remove adjusting shim from reduction pinion gear.

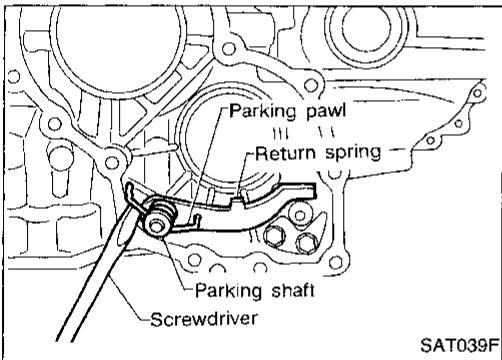

41. Remove return spring from parking shaft with screwdriver.

42. Draw out parking shaft and remove parking pawl from transmission case.

43. Check parking pawl and shaft for damage or wear.

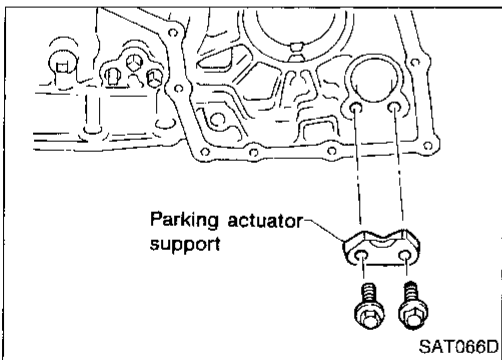

44. Remove parking actuator support from transmission case.

45. Check parking actuator support for damage or wear.

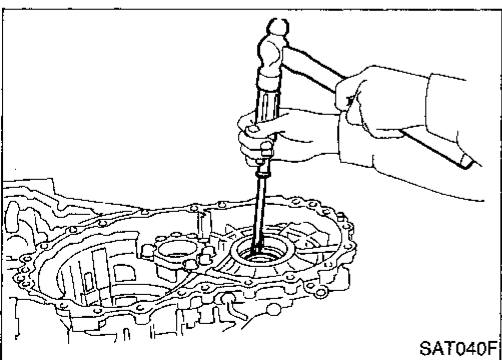

46. Remove side oil seal with screwdriver from transmission case.

Manual Shaft

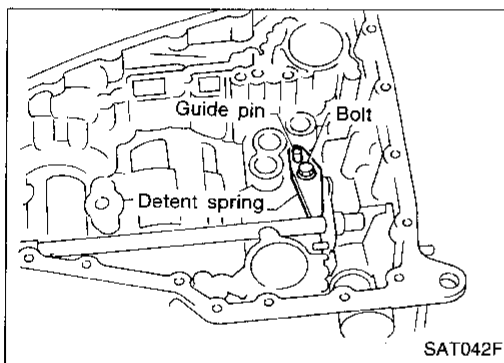
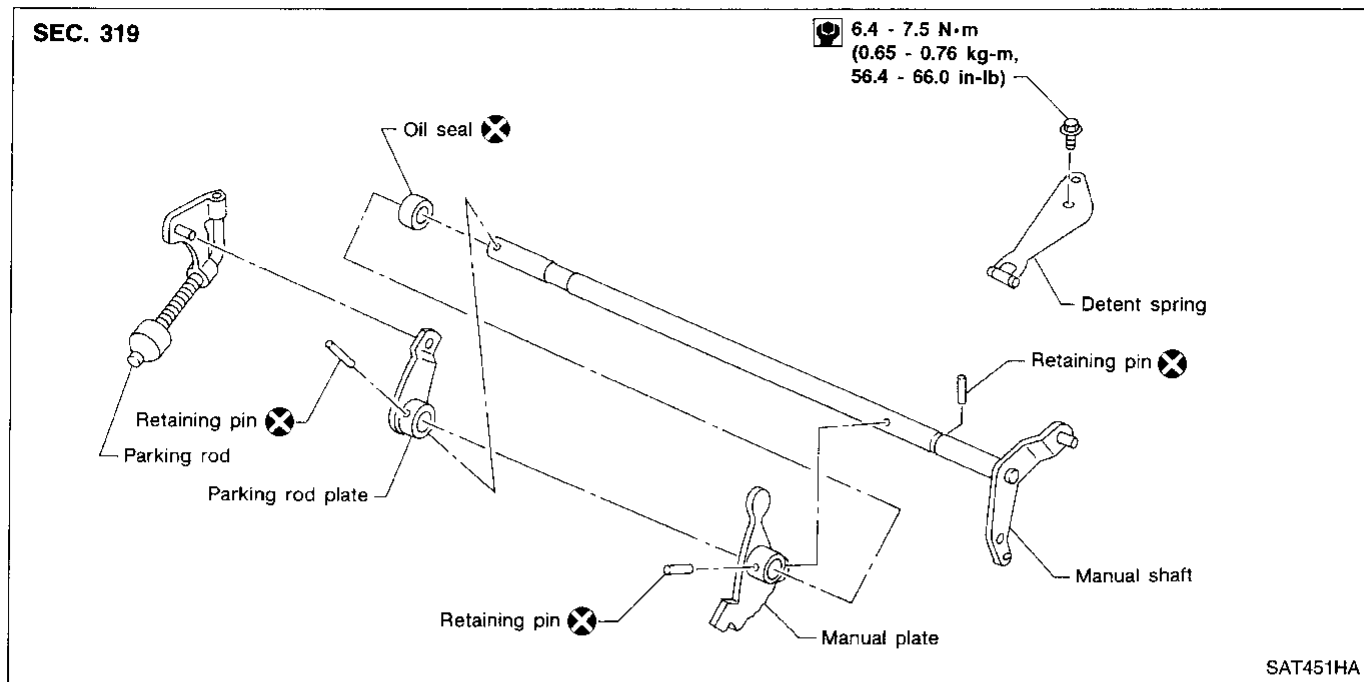

REMOVAL

1. Remove detent spring from transmission case.

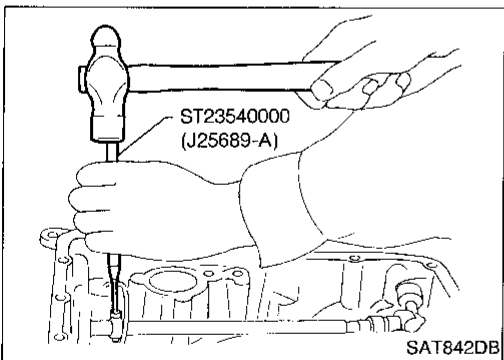

2. Drive out manual plate retaining pin.

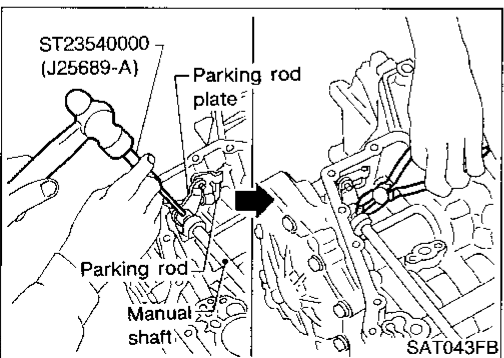

3. Drive and pull out parking rod plate retaining pin.
4. Remove parking rod plate from manual shaft.
5. Draw out parking rod from transmission case.

REPAIR FOR COMPONENT PARTS

Manual Shaft (Cont'd)

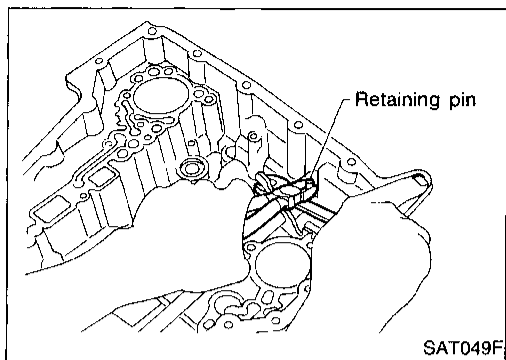

6. Pull out manual shaft retaining pin.
7. Remove manual shaft and manual plate from transmission case.

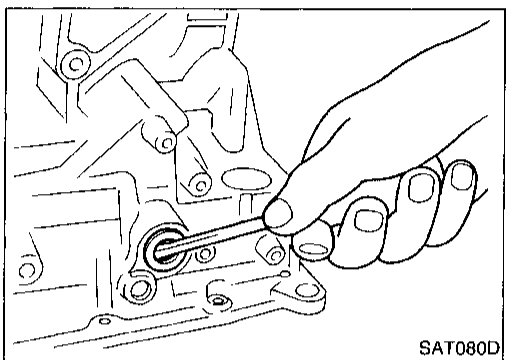

8. Remove manual shaft oil seal.

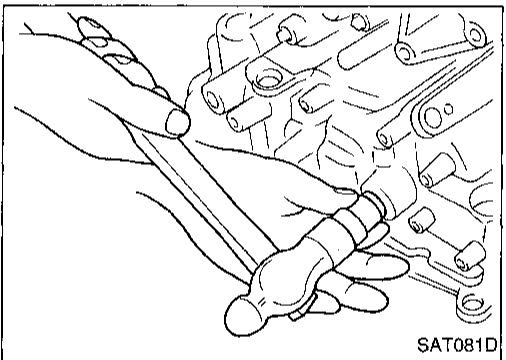

INSPECTION

- Check component parts for wear or damage. Replace if necessary.

INSTALLATION

1. Install manual shaft oil seal.
- **Apply ATF to outer surface of oil seal.**

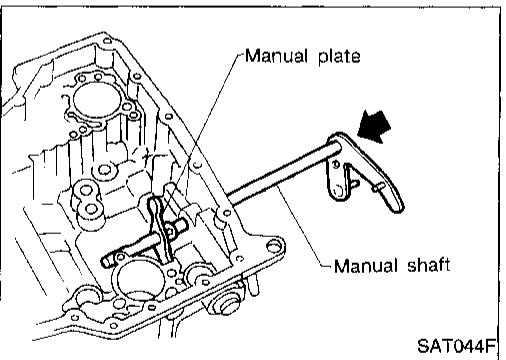

2. Install manual shaft and manual plate.

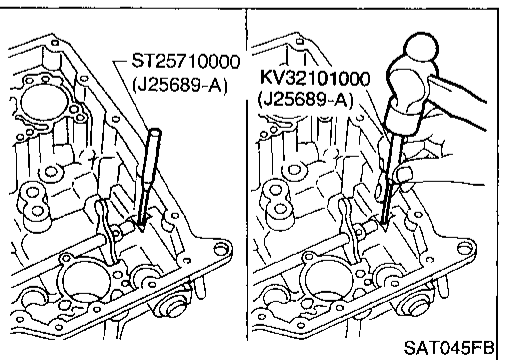

3. Align groove of manual shaft and hole of transmission case.
4. Install manual shaft retaining pin up to bottom of hole.

REPAIR FOR COMPONENT PARTS

Manual Shaft (Cont'd)

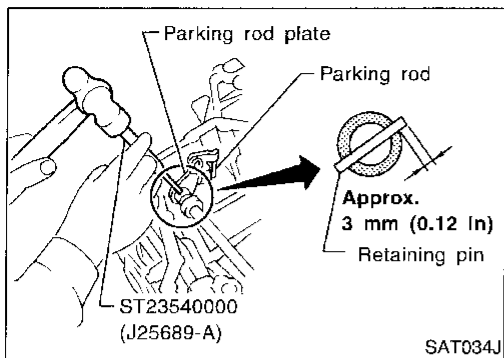

5. Install parking rod to parking rod plate.
 6. Set parking rod assembly onto manual shaft and drive retaining pin.
- Both ends of pin should protrude.

GI

MA

EM

LC

EC

FE

CL

MT

AT

FA

RA

BR

ST

RS

BT

HA

EL

IDX

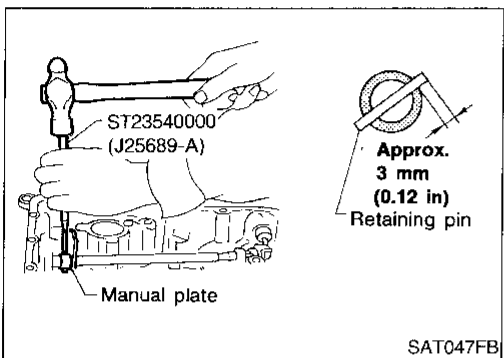

7. Drive manual plate retaining pin.
- Both ends of pin should protrude.

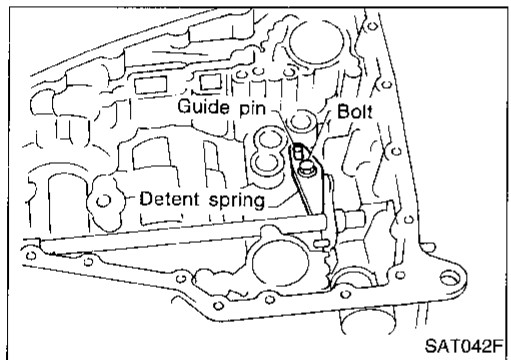

8. Install detent spring.

Oil Pump

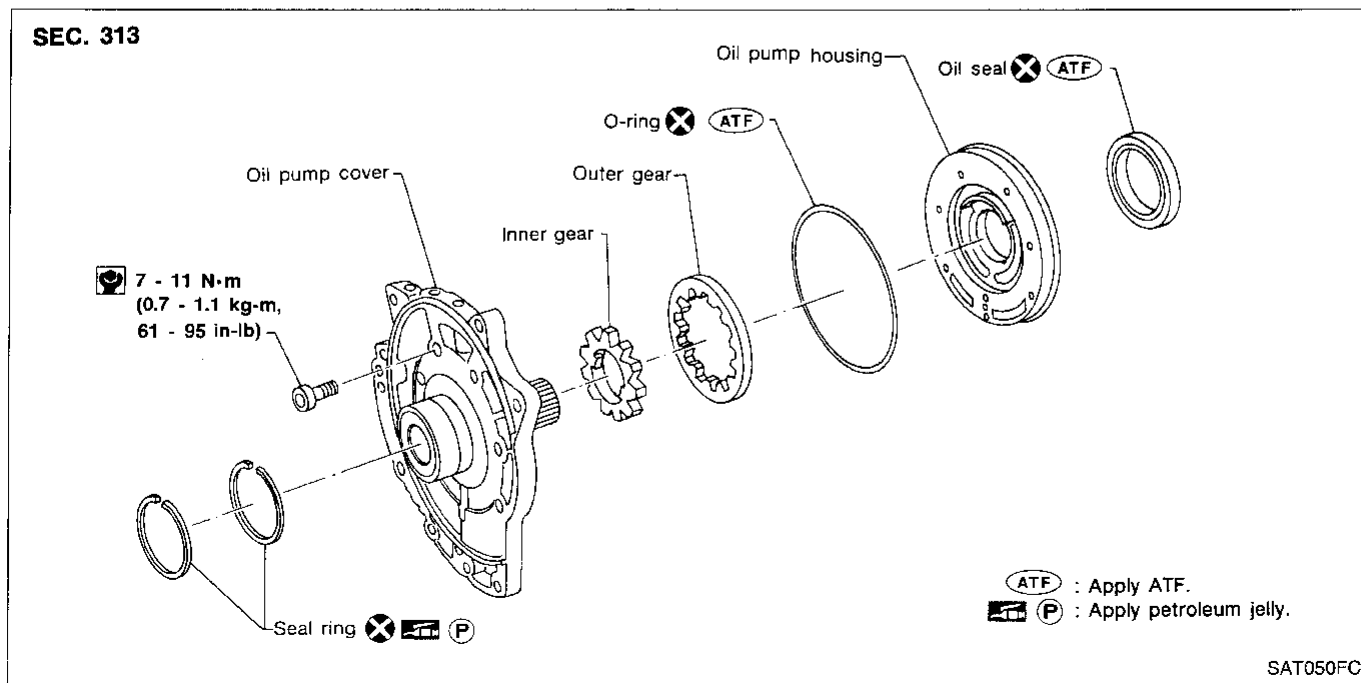

REPAIR FOR COMPONENT PARTS

Oil Pump (Cont'd)

DISASSEMBLY

1. Remove seal rings.

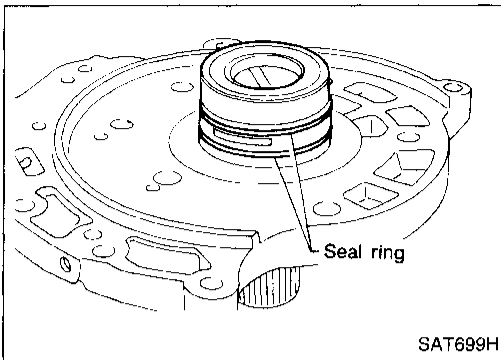

2. Loosen bolts in a crisscross pattern and remove oil pump cover.

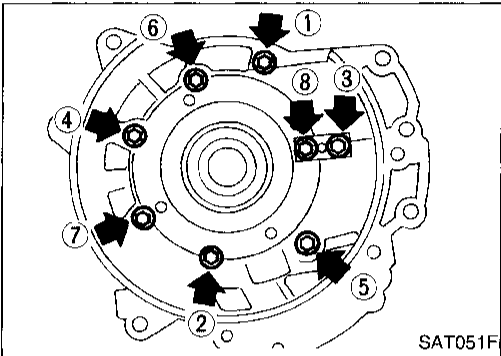

3. Remove inner and outer gear from oil pump housing.

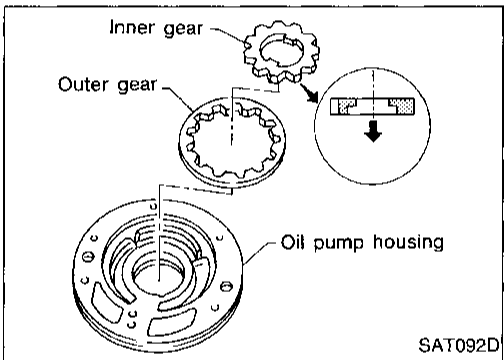

4. Remove O-ring from oil pump housing.

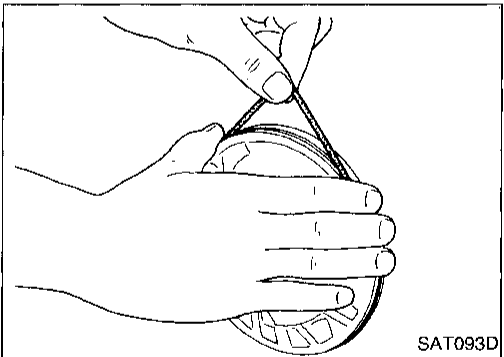

5. Remove oil pump housing oil seal.

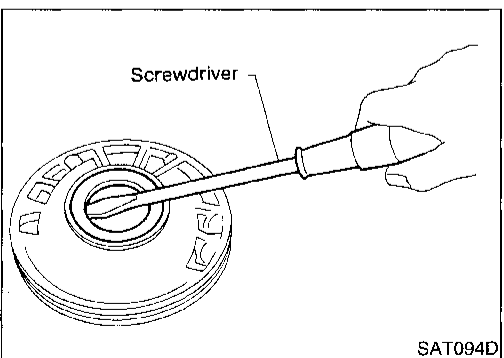

REPAIR FOR COMPONENT PARTS

Oil Pump (Cont'd)

INSPECTION

Oil pump housing, oil pump cover, inner gear and outer gear

- Check for wear or damage.

GI

MA

EM

LC

EC

FE

CL

MT

AT

FA

RA

BR

ST

RS

BT

HA

EL

IDX

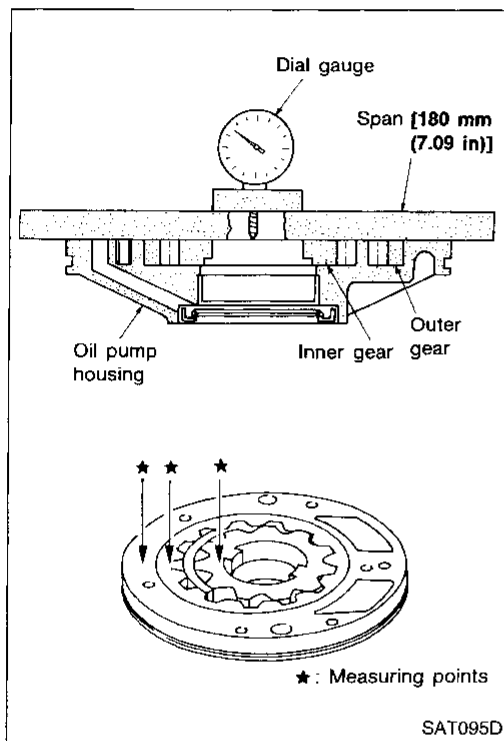

Side clearance

- Measure side clearance of inner and outer gears in at least four places around each outside edge. Maximum measured values should be within specified positions.

Standard clearance:

0.030 - 0.050 mm (0.0012 - 0.0020 in)

- If clearance is less than standard, select inner and outer gear as a set so that clearance is within specifications.

Inner and outer gear:

Refer to SDS, AT-305.

- If clearance is more than standard, replace whole oil pump assembly except oil pump cover.

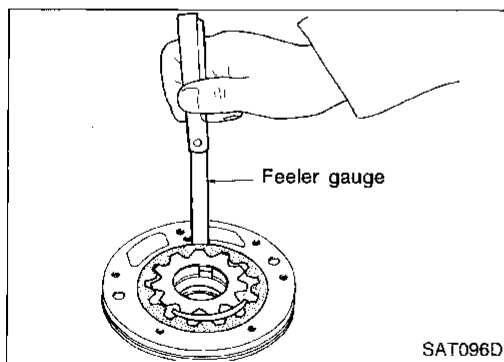

- Measure clearance between outer gear and oil pump housing.

Standard clearance:

0.111 - 0.181 mm (0.0044 - 0.0071 in)

Allowable limit:

0.181 mm (0.0071 in)

- If not within allowable limit, replace whole oil pump assembly except oil pump cover.

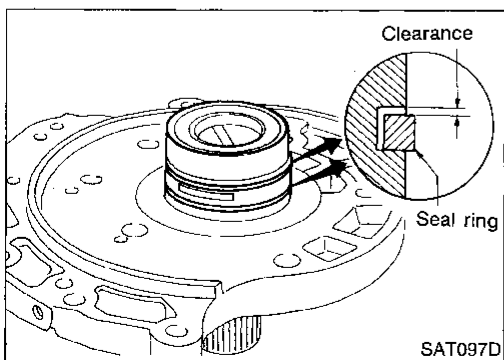

Seal ring clearance

- Measure clearance between seal ring and ring groove.

Standard clearance:

0.1 - 0.25 mm (0.0039 - 0.0098 in)

Allowable limit:

0.25 mm (0.0098 in)

- If not within allowable limit, replace oil pump cover assembly.

REPAIR FOR COMPONENT PARTS

Oil Pump (Cont'd)

ASSEMBLY

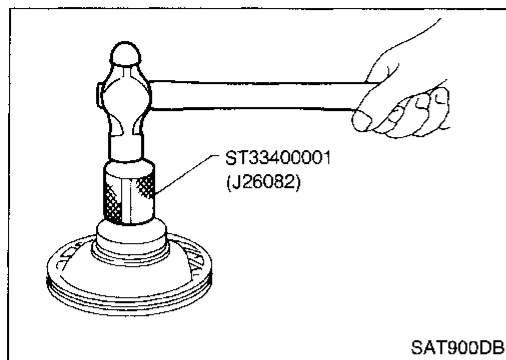

1. Install oil seal on oil pump housing.

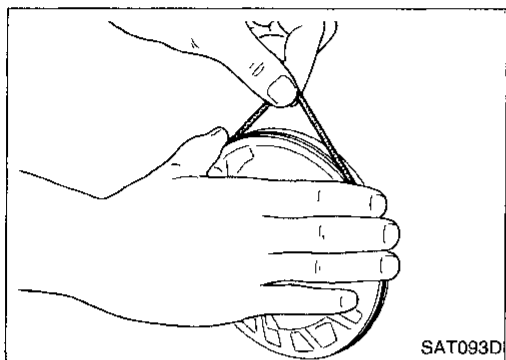

2. Install O-ring on oil pump housing.
 - Apply ATF to O-ring.

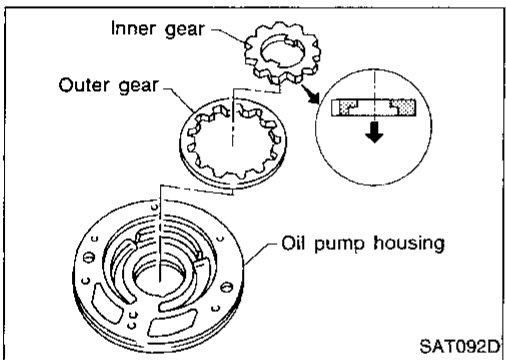

3. Install inner and outer gears on oil pump housing.
 - Be careful of direction of inner gear.

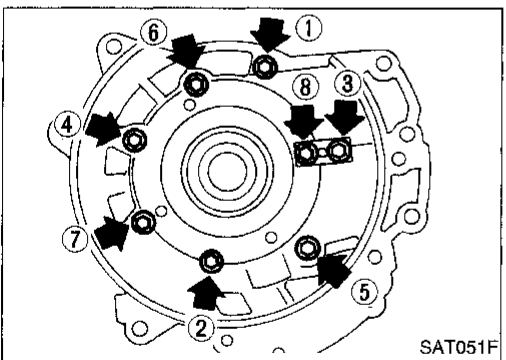

4. Install oil pump cover on oil pump housing.
 - a. Wrap masking tape around splines of oil pump cover assembly to protect seal. Position oil pump cover assembly on oil pump housing assembly, then remove masking tape.
 - b. Tighten bolts in a crisscross pattern.
 - ☑: 7 - 11 N·m (0.7 - 1.1 kg-m, 61 - 95 in-lb)

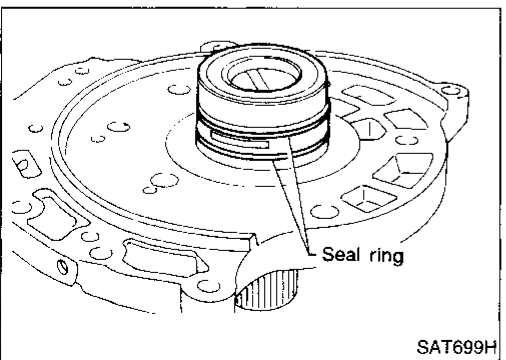

5. Install new seal rings carefully after packing ring groove with petroleum jelly.
 - Do not spread gap of seal ring excessively while installing. The ring may be deformed.

Control Valve Assembly

SEC. 317

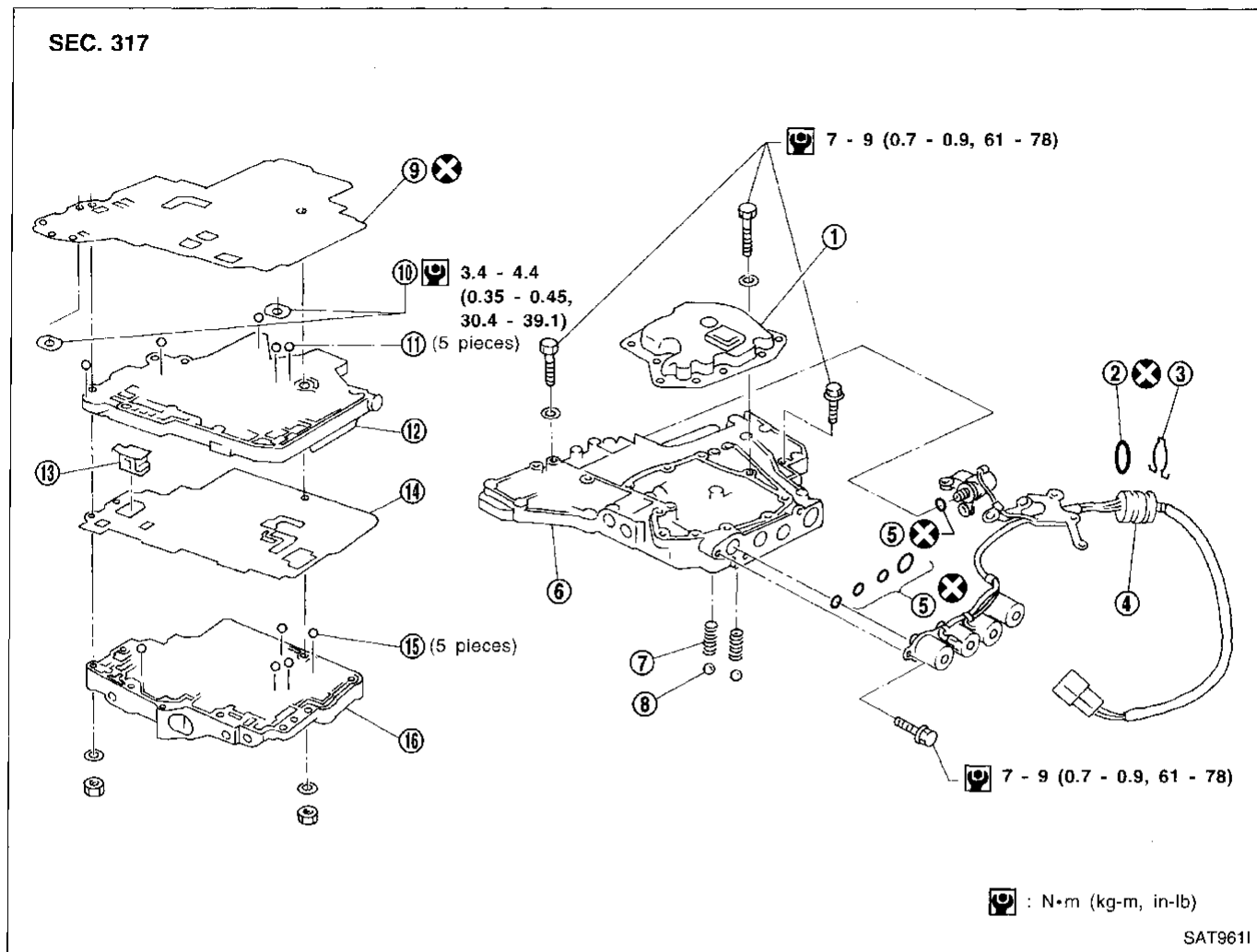

- ① Oil strainer
- ② O-ring
- ③ Stopper ring
- ④ Terminal body
- ⑤ O-rings
- ⑥ Control valve lower body
- ⑦ Oil cooler relief valve spring
- ⑧ Check ball
- ⑨ Separating plate
- ⑩ Support plate
- ⑪ Steel ball
- ⑫ Control valve inter body
- ⑬ Pilot filter
- ⑭ Separating plate
- ⑮ Steel ball
- ⑯ Control valve upper body

DISASSEMBLY

Disassemble upper, inter and lower bodies.

Bolt length, number and location:

Bolt symbol	a	b	c	d	e	f
Bolt length "ℓ" mm (in)	13.5 (0.531)	58.0 (2.283)	40.0 (1.575)	66.0 (2.598)	33.0 (1.299)	78.0 (3.071)
Number of bolts	6	3	6	11	2	2

f: Reamer bolt and nut.

GI
MA
EM
LC
EC
FE
CL
MT
AT
FA
RA
BR
ST
RS
BT
HA
EL
IDX

REPAIR FOR COMPONENT PARTS

Control Valve Assembly (Cont'd)

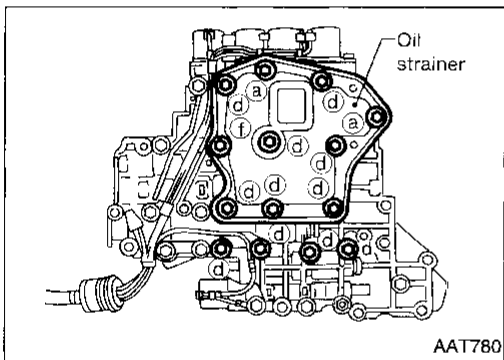
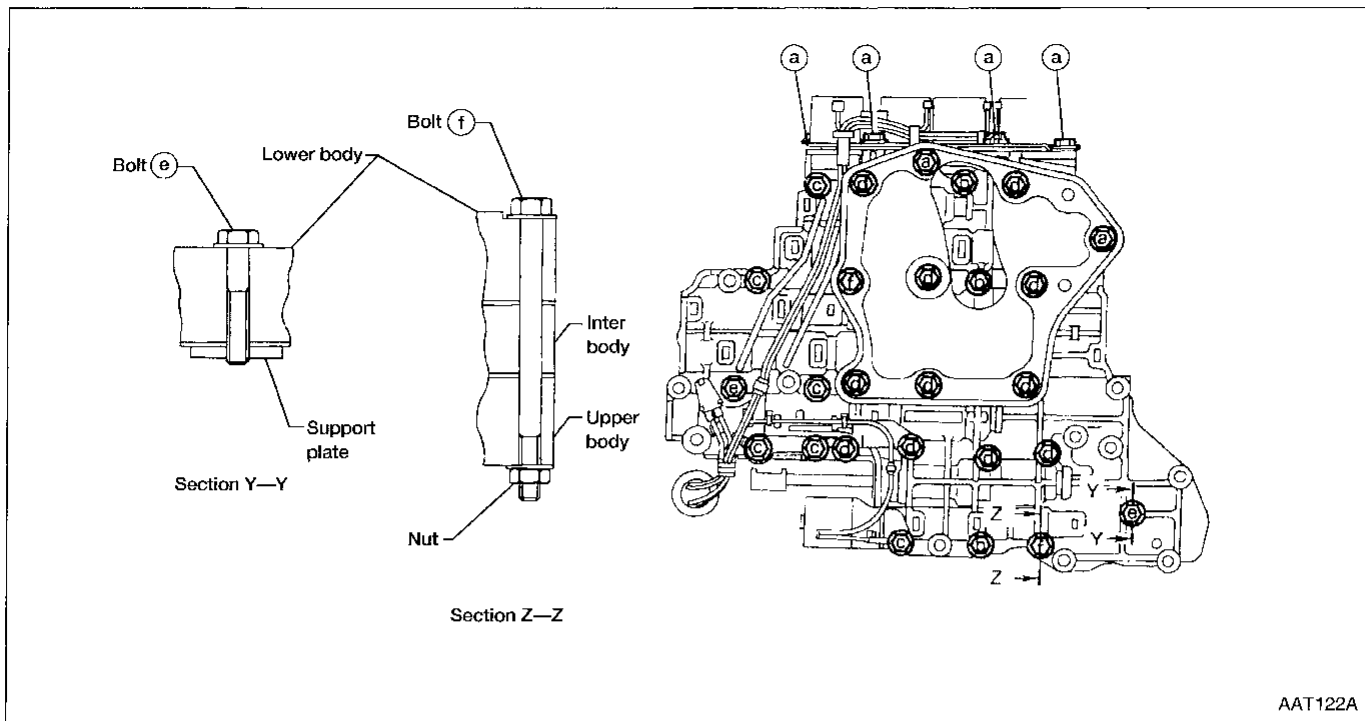

a. Remove bolts (a), (d) and (f) and remove oil strainer from control valve assembly.

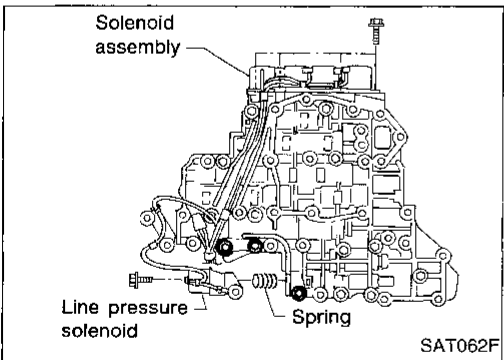

b. Remove solenoid valve assembly and line pressure solenoid valve from control valve assembly.

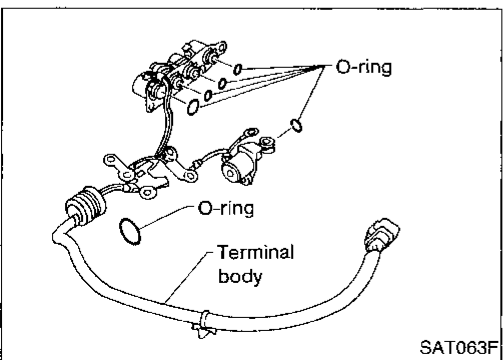

c. Remove O-rings from solenoid valves and terminal body.

REPAIR FOR COMPONENT PARTS

Control Valve Assembly (Cont'd)

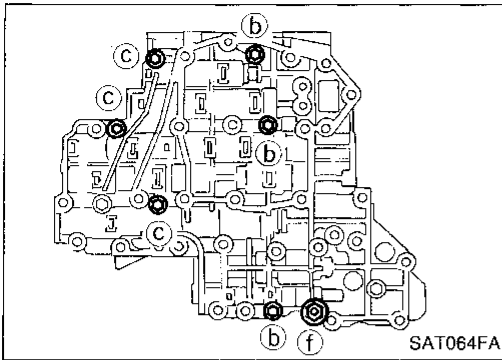

- d. Place upper body facedown, and remove bolts (b), (c) and nut (f).

GI

MA

EM

LC

EC

FE

CL

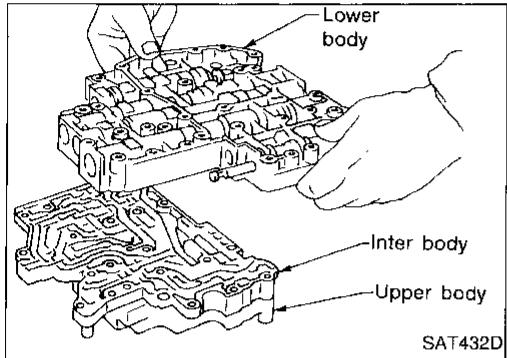

- e. Remove inter body from lower body.

MT

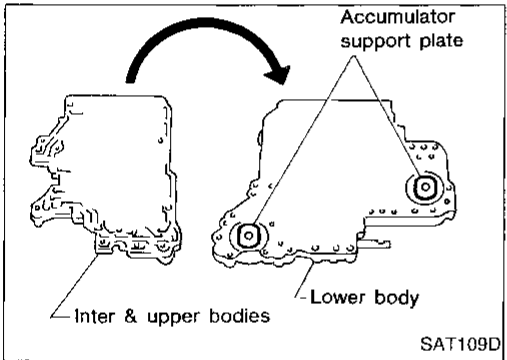

- f. Turn over lower body, and remove accumulator support plate.

AT

FA

RA

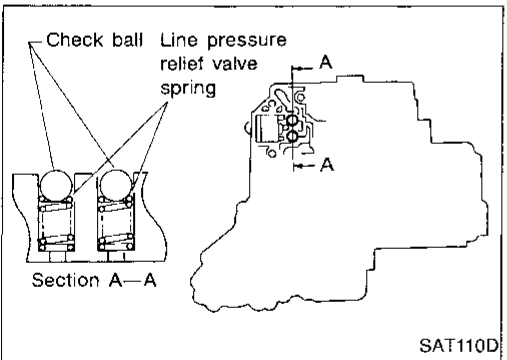

- g. Remove bolts (e), separating plate and separating gasket from lower body.
 h. Remove steel balls and relief valve springs from lower body.
 • **Be careful not to lose steel balls and relief valve springs.**

BR

ST

RS

BT

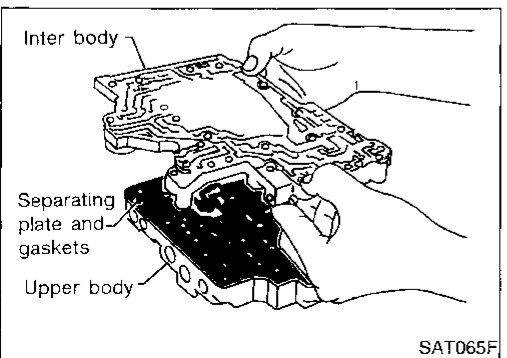

- i. Remove inter body from upper body.

HA

EL

IDX

REPAIR FOR COMPONENT PARTS

Control Valve Assembly (Cont'd)

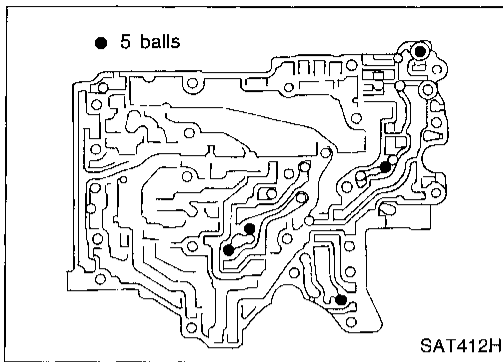

- j. Check to see that steel balls are properly positioned in inter body and then remove them.
- **Be careful not to lose steel balls.**

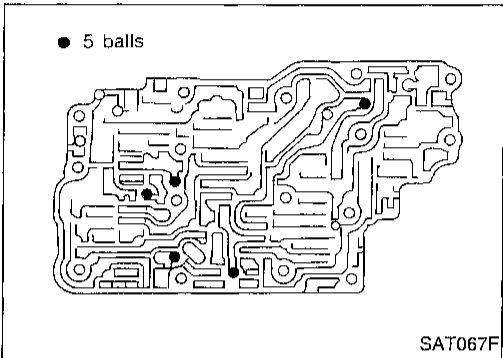

- k. Check to see that steel balls are properly positioned in upper body and then remove them.
- **Be careful not to lose steel balls.**

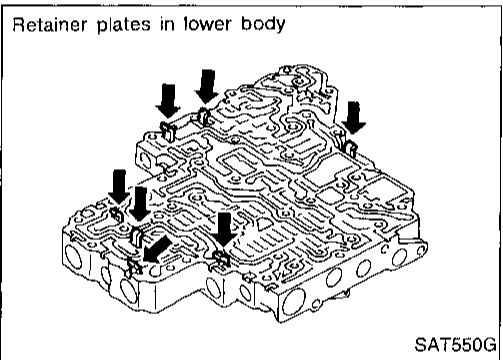

INSPECTION

Lower and upper bodies

- Check to see that retainer plates are properly positioned in lower body.

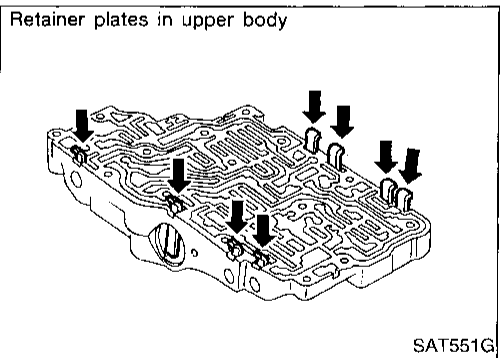

- Check to see that retainer plates are properly positioned in upper body.
- **Be careful not to lose these parts.**

Oil strainer

- Check wire netting of oil strainer for damage.

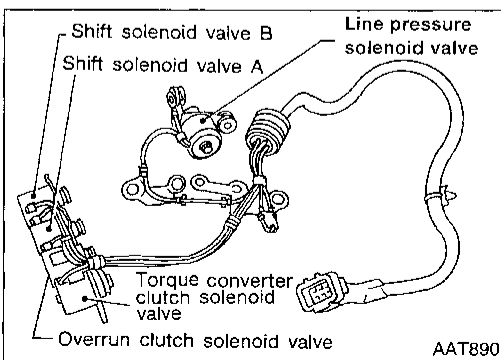

Shift solenoid valves "A" and "B", line pressure solenoid valve, torque converter clutch solenoid valve and overrun clutch solenoid valve

- Measure resistance. Refer to "Components Inspection", AT-121.

REPAIR FOR COMPONENT PARTS

Control Valve Assembly (Cont'd)

Oil cooler relief valve spring

- Check springs for damage or deformation.
- Measure free length and outer diameter.

Inspection standard:

Unit: mm (in)		
Part No.	ℓ	D
31872-31X00	17.02 (0.6701)	8.0 (0.315)

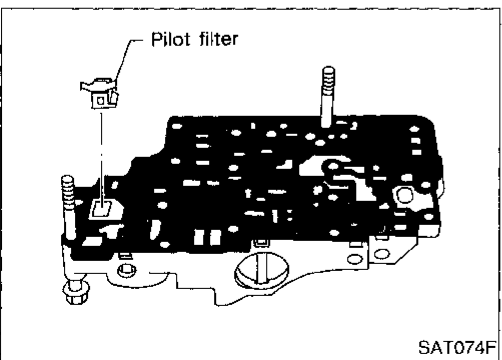
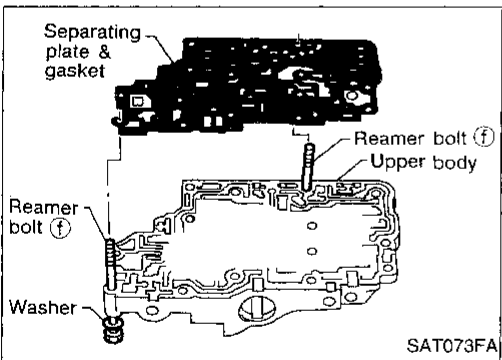
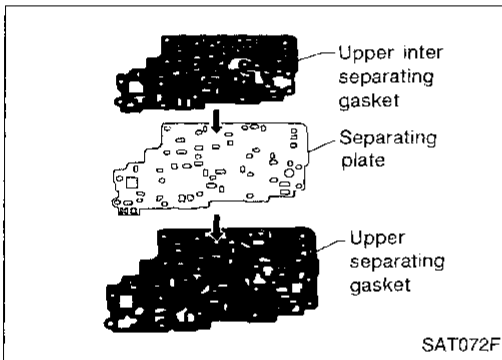
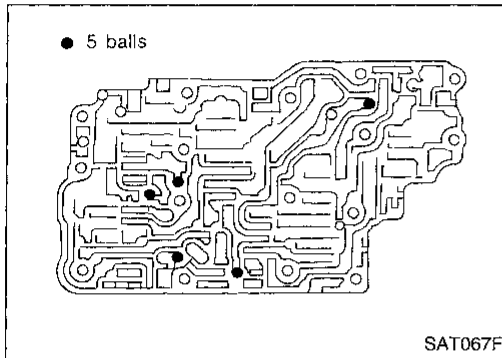
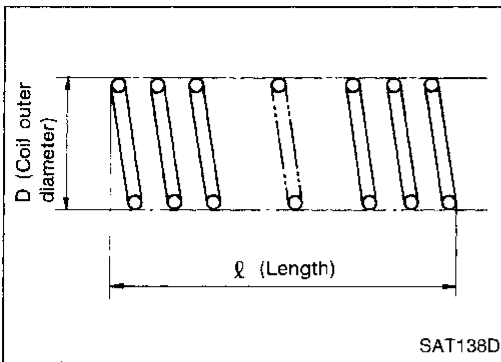

ASSEMBLY

1. Install upper, inter and lower body.
 - a. Place oil circuit of upper body face up. Install steel balls in their proper positions.

- b. Install upper separating gasket, upper inter separating gasket and upper separating plate in order shown in illustration.

- c. Install reamer bolts (f) from bottom of upper body. Using reamer bolts as guides, install separating plate and gaskets as a set.

- d. Install pilot filter.

GI

MA

EM

LC

EC

FE

CL

MT

AT

FA

RA

BR

ST

RS

BT

HA

EL

IDX

REPAIR FOR COMPONENT PARTS

Control Valve Assembly (Cont'd)

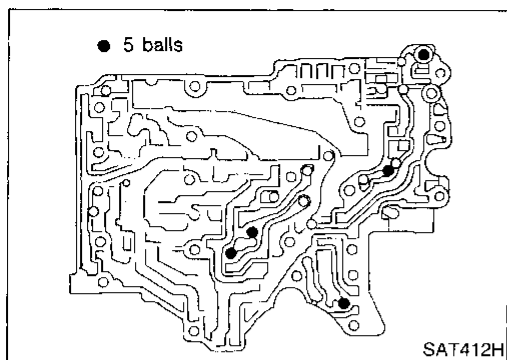

- e. Place lower body as shown in illustration (side of inter body face up). Install steel balls in their proper positions.

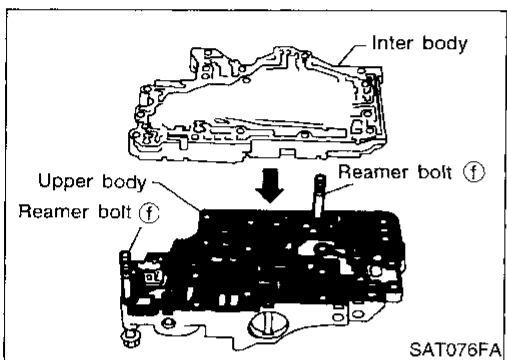

- f. Install inter body on upper body using reamer bolts (f) as guides.

- Be careful not to dislocate or drop steel balls.

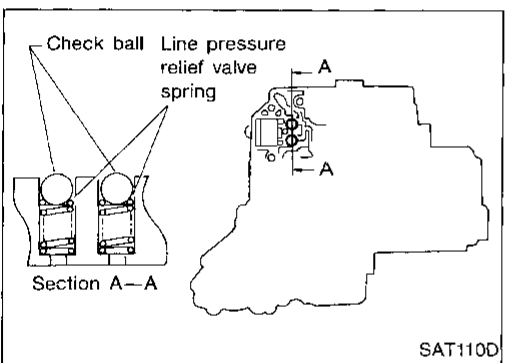

- g. Install steel balls and relief valve springs in their proper positions in lower body.

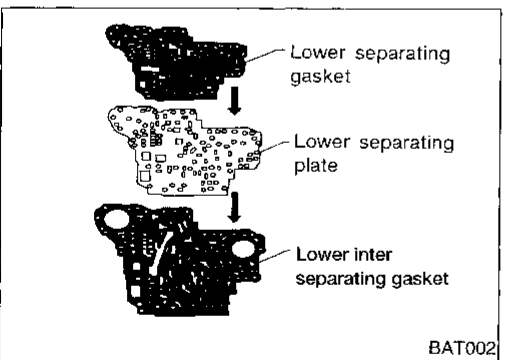

- h. Install lower separating gasket, lower inter separating gasket and lower separating plate in order shown in illustration.

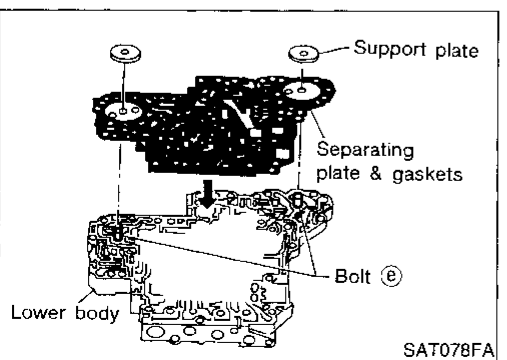

- i. Install bolts (e) from bottom of lower body. Using bolts (e) as guides, install separating plate and gaskets as a set.
- j. Temporarily install support plates on lower body.

REPAIR FOR COMPONENT PARTS

Control Valve Assembly (Cont'd)

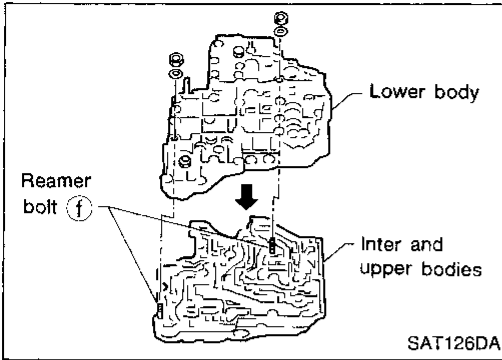

- k. Install lower body on inter body using reamer bolts (f) as guides and tighten reamer bolts (f) slightly.

GI

MA

EM

LC

EC

FE

CL

MT

AT

FA

RA

BR

ST

RS

BT

HA

EL

IDX

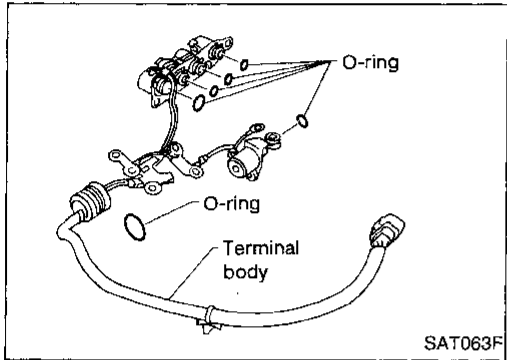

2. Install O-rings to solenoid valves and terminal body.
- Apply ATF to O-rings.

3. Install and tighten bolts.

Bolt length, number and location:

Bolt symbol	(a)	(b)	(c)	(d)	(e)	(f)	
Bolt length "ℓ"							
 ℓ	mm (in)	13.5 (0.531)	58.0 (2.283)	40.0 (1.575)	66.0 (2.598)	33.0 (1.299)	78.0 (3.071)
Number of bolts	6	3	6	11	2	2	

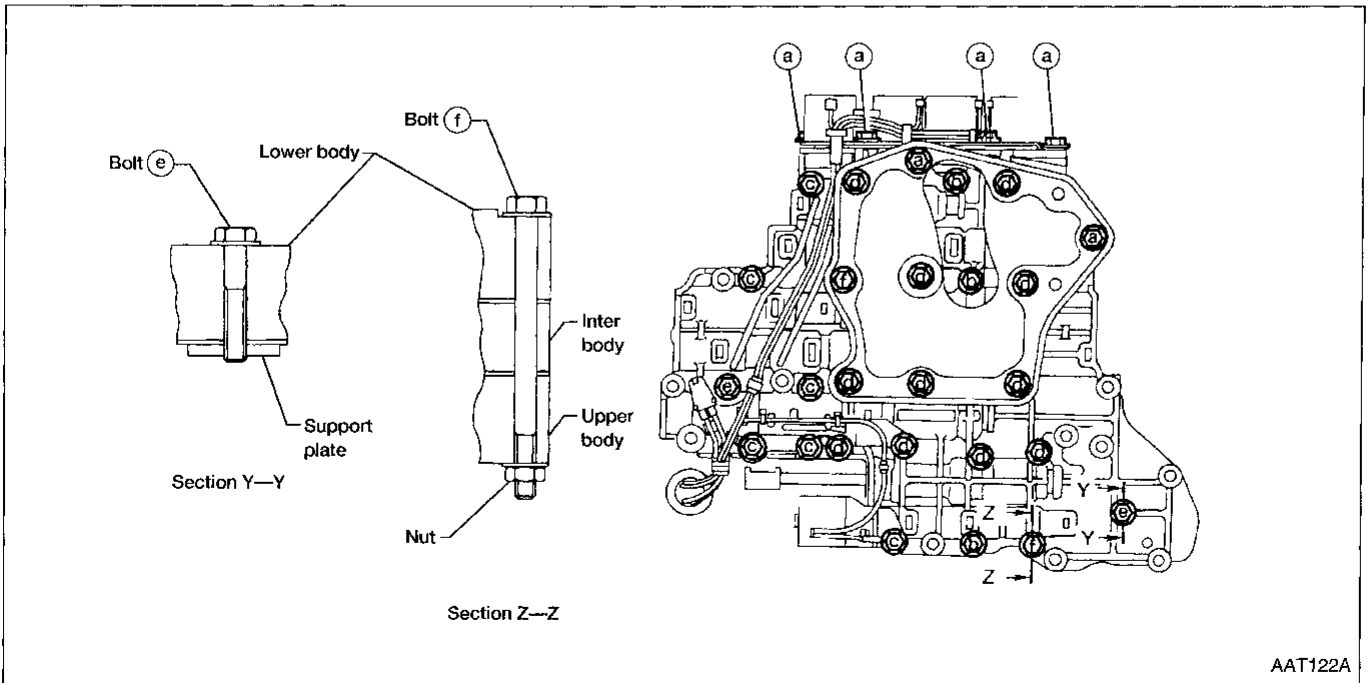

REPAIR FOR COMPONENT PARTS

Control Valve Assembly (Cont'd)

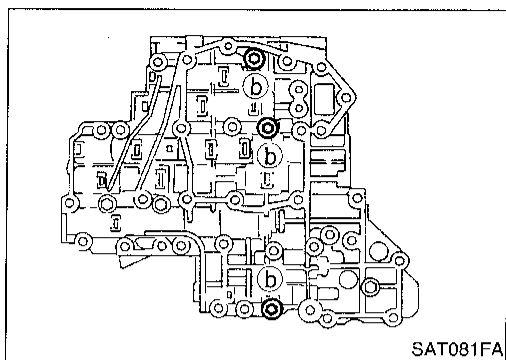

- a. Install and tighten bolts (b) to specified torque.
☑ : 7 - 9 N·m (0.7 - 0.9 kg-m, 61 - 78 in-lb)

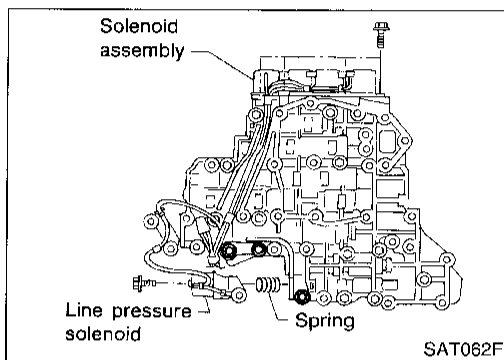

- b. Install solenoid valve assembly and line pressure solenoid valve to lower body.

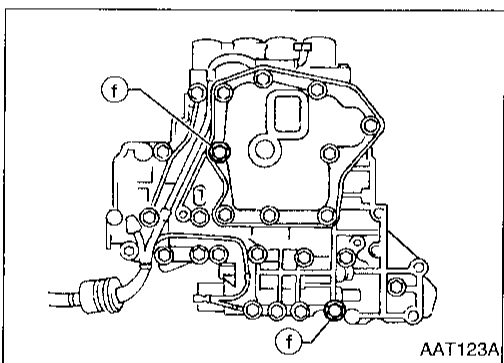

- c. Remove reamer bolts (f) and set oil strainer on control valve assembly.
d. Reinstall reamer bolts (f) from lower body side.

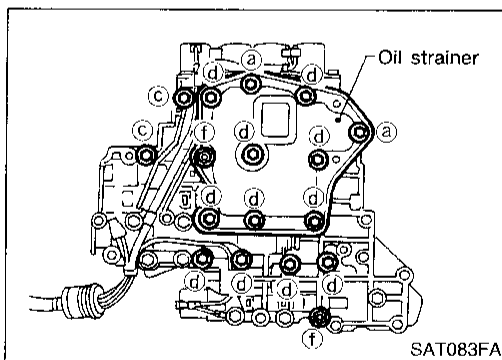

- e. Tighten bolts (a), (c), (d) and (f) to specified torque.
☑ : 7 - 9 N·m (0.7 - 0.9 kg-m, 61 - 78 in-lb)

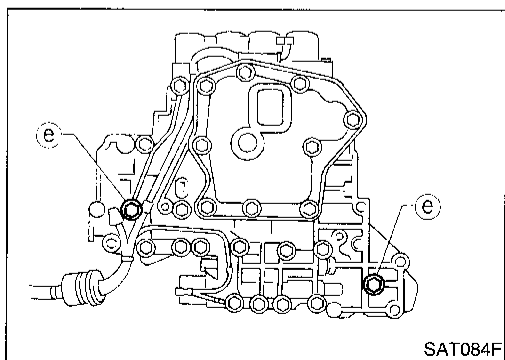

- f. Tighten bolts (e) to specified torque.
☑ : 3.4 - 4.4 N·m (0.35 - 0.45 kg-m, 30.4 - 39.1 in-lb)

Control Valve Upper Body

SEC. 317

GI

MA

EM

LC

EC

FE

CL

MT

AT

FA

RA

BR

ST

SAT859H

RS

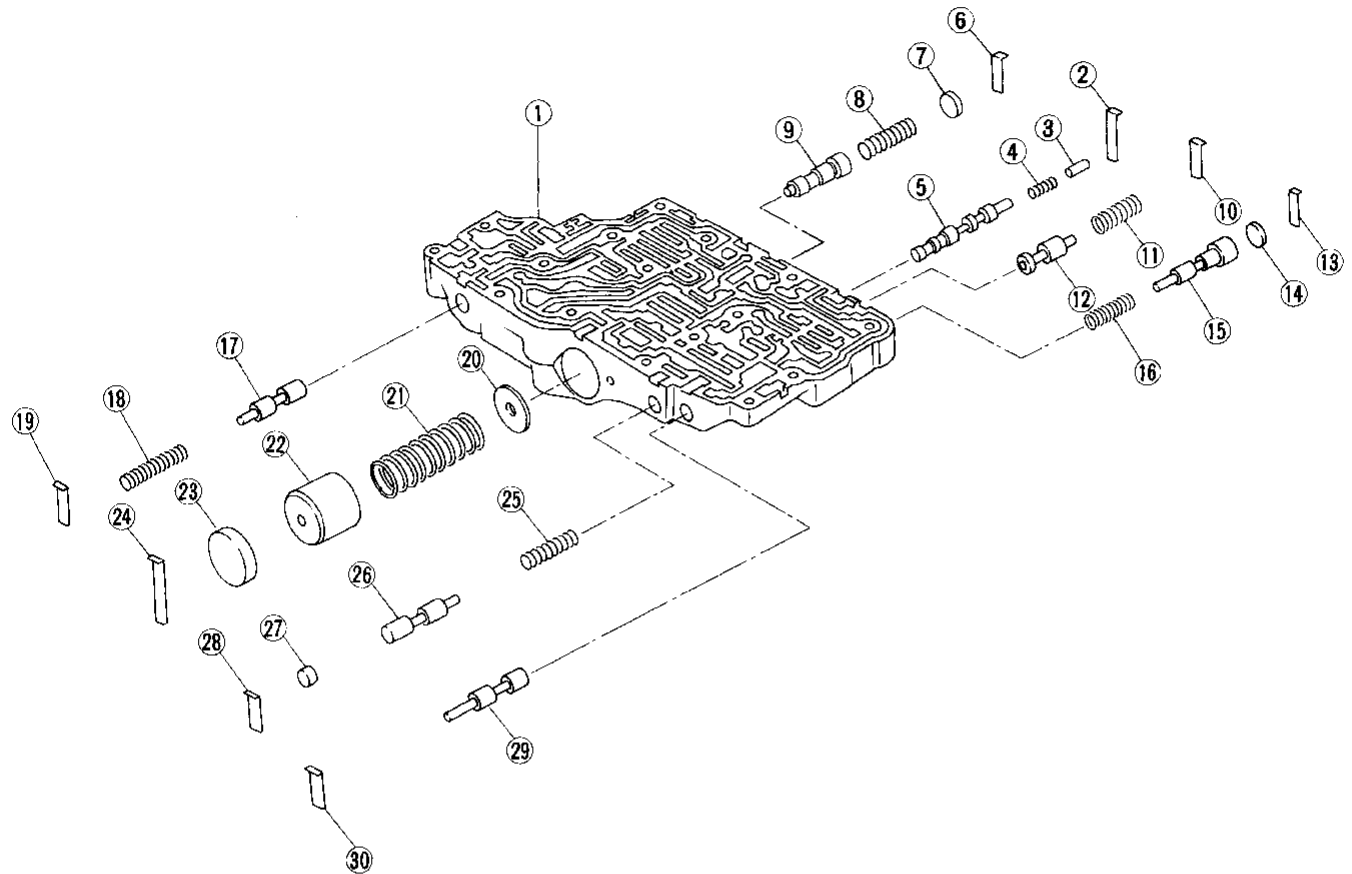

BT

HA

EL

IDX

Apply ATF to all components before installation.

- | | | |
|---|----------------------------------|--------------------------|
| ① Upper body | ⑪ Return spring | ⑳ Return spring |
| ② Retainer plate | ⑫ Torque converter relief valve | ㉑ 1-2 accumulator piston |
| ③ Plug | ⑬ Retainer plate | ㉒ Plug |
| ④ Return spring | ⑭ Plug | ㉓ Retainer plate |
| ⑤ Torque converter clutch control valve | ⑮ Overrun clutch reducing valve | ㉔ Return spring |
| ⑥ Retainer plate | ⑯ Return spring | ㉕ 1st reducing valve |
| ⑦ Plug | ⑰ Pilot valve | ㉖ Plug |
| ⑧ Return spring | ⑱ Retainer plate | ㉗ Retainer plate |
| ⑨ 1-2 accumulator valve | ㉘ Retainer plate | ㉙ Plug |
| ⑩ Retainer plate | ㉚ 1-2 accumulator retainer plate | ㉚ Retainer plate |

REPAIR FOR COMPONENT PARTS

Control Valve Upper Body (Cont'd)

DISASSEMBLY

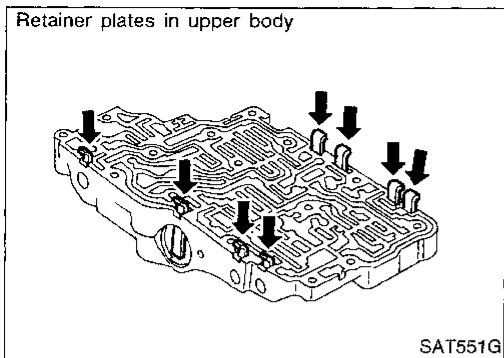

1. Remove valves at retainer plates.
- Do not use a magnetic pick-up tool.

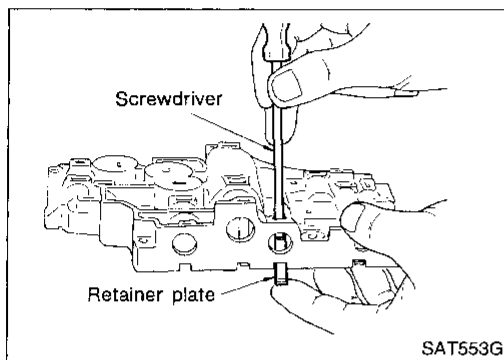

- a. Use a screwdriver to remove retainer plates.

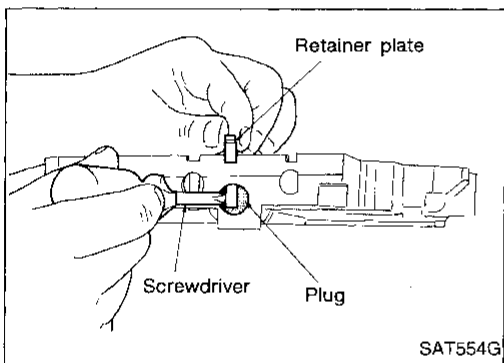

- b. Remove retainer plates while holding spring, plugs or sleeves.
- Remove plugs slowly to prevent internal parts from jumping out.

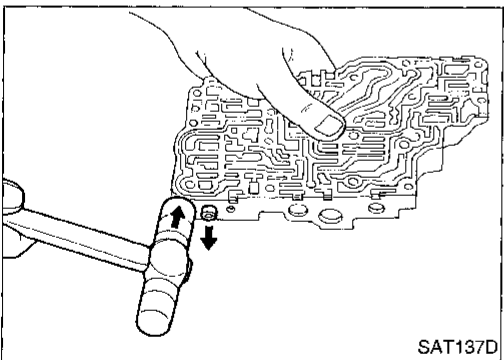

- c. Place mating surface of valve body face down, and remove internal parts.
- If a valve is hard to remove, place valve body face down and lightly tap it with a soft hammer.
 - Be careful not to drop or damage valves and sleeves.

INSPECTION

Valve spring

- Measure free length and outer diameter of each valve spring. Also check for damage or deformation.

Inspection standard:

Refer to SDS, AT-302.

- Replace valve springs if deformed or fatigued.

Control valves

- Check sliding surfaces of valves, sleeves and plugs.

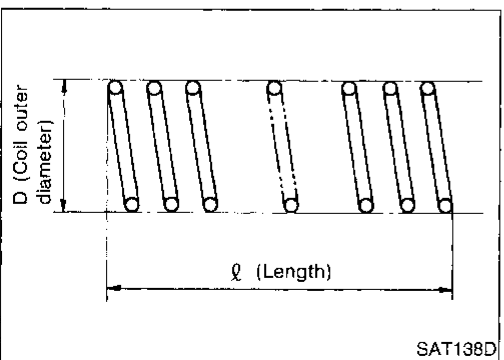

REPAIR FOR COMPONENT PARTS

Control Valve Upper Body (Cont'd)

ASSEMBLY

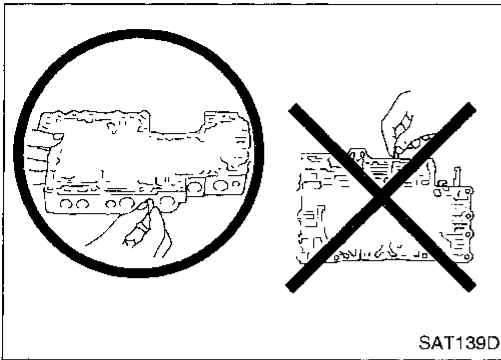

- Lay control valve body down when installing valves. Do not stand the control valve body upright.

GI

MA

EM

LC

EC

FE

CL

MT

AT

FA

RA

BR

ST

RS

BT

HA

EL

IDX

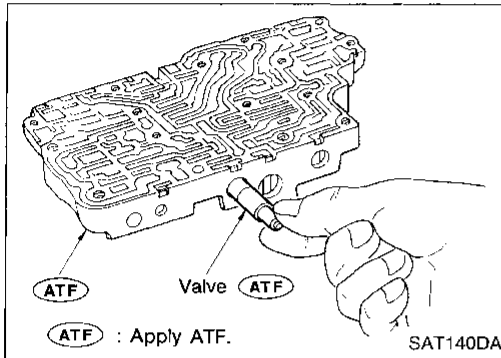

1. Lubricate the control valve body and all valves with ATF. Install control valves by sliding them carefully into their bores.

- Be careful not to scratch or damage valve body.

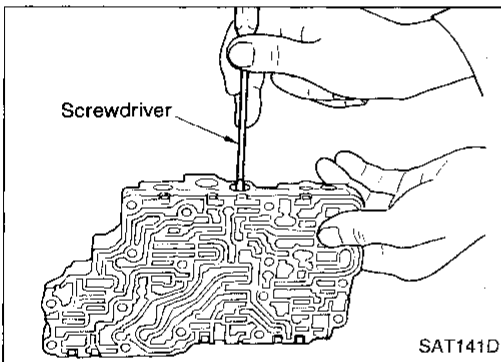

- Wrap a small screwdriver with vinyl tape and use it to insert the valves into their proper positions.

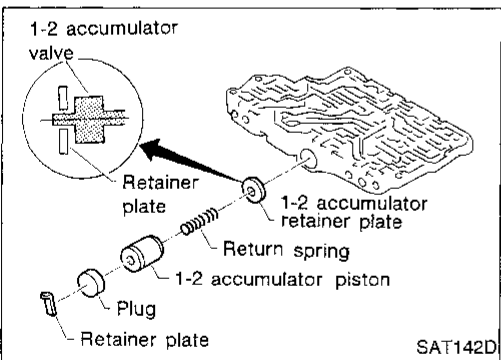

1-2 accumulator valve

- Install 1-2 accumulator valve. Align 1-2 accumulator retainer plate from opposite side of control valve body.
- Install return spring, 1-2 accumulator piston and plug.

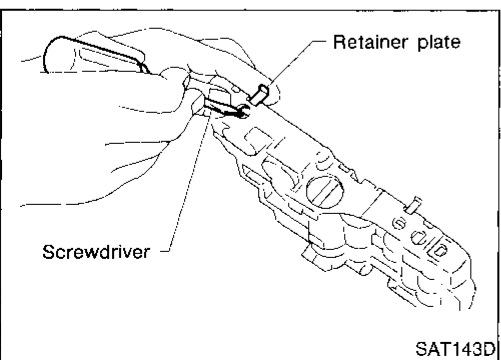

2. Install retainer plates
- While pushing plug or return spring, install retainer plate.

REPAIR FOR COMPONENT PARTS

Control Valve Upper Body (Cont'd)

Retainer plate

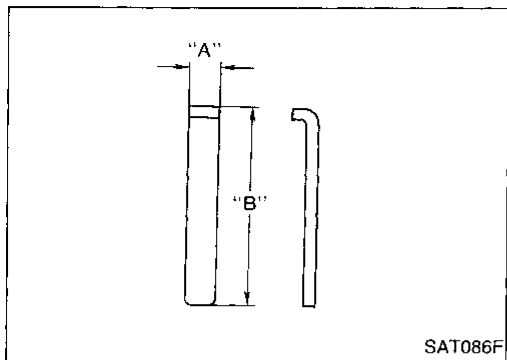

Unit: mm (in)

Name of control valve	Length A	Length B
Pilot valve	6.0 (0.236)	21.5 (0.846)
1st reducing valve		
Torque converter relief valve		
Plug		38.5 (1.516)
1-2 accumulator valve		
1-2 accumulator piston valve		
Overrun clutch reducing valve		
Torque converter clutch control valve		24.0 (0.945)
		28.0 (1.102)

- Install proper retainer plates.

Control Valve Lower Body

SEC. 317

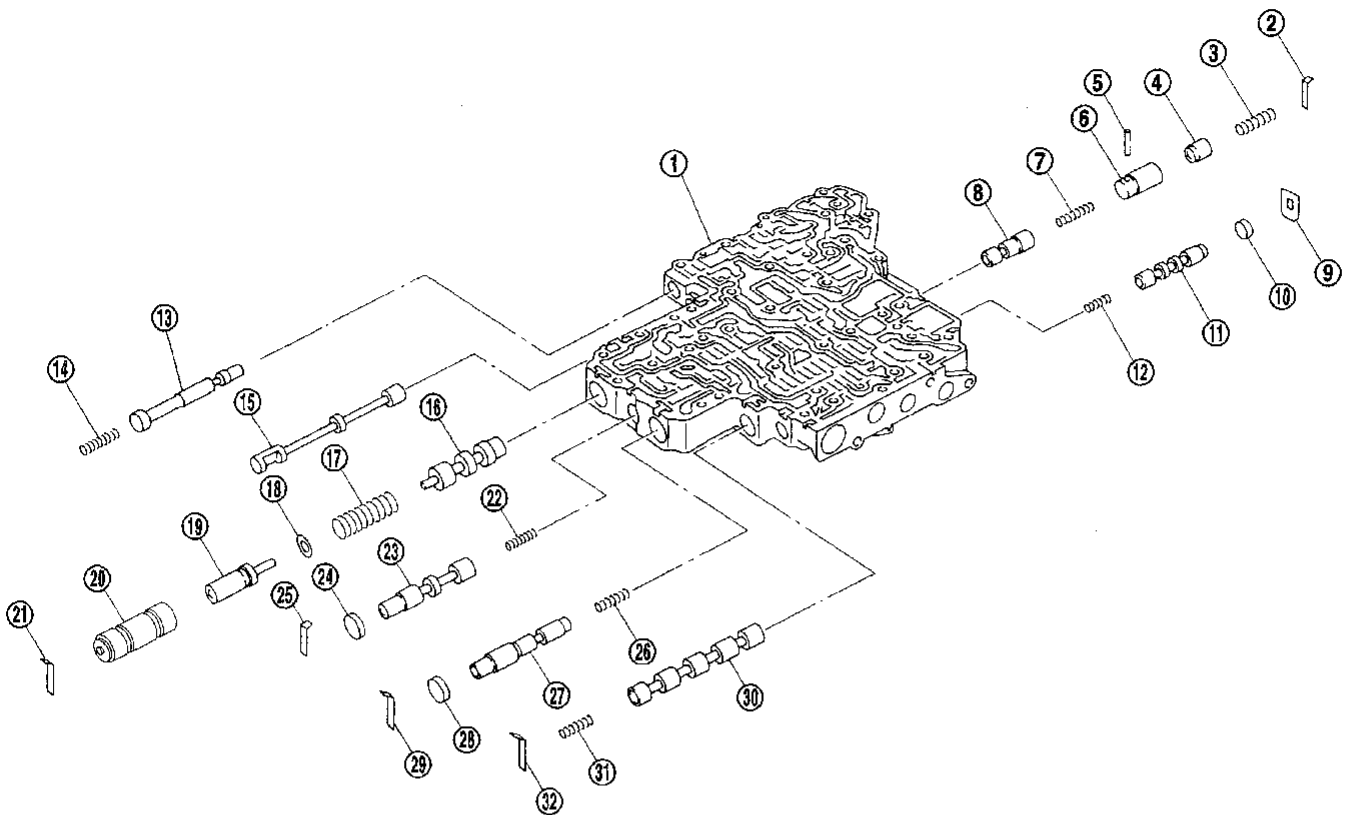

Apply ATF to all components before installation.

- | | | |
|---------------------------|----------------------------|--------------------------------|
| ① Lower body | ⑫ Return spring | ⑳ Overrun clutch control valve |
| ② Retainer plate | ⑬ Plug | ㉑ Plug |
| ③ Return spring | ⑭ Return spring | ㉒ Retainer plate |
| ④ Piston | ⑮ Manual valve | ㉓ Return spring |
| ⑤ Parallel pin | ⑯ Pressure regulator valve | ㉔ Accumulator control valve |
| ⑥ Sleeve | ⑰ Return spring | ㉕ Plug |
| ⑦ Return spring | ⑱ Spring seat | ㉖ Retainer plate |
| ⑧ Pressure modifier valve | ㉒ Plug | ㉗ Shift valve A |
| ⑨ Retainer plate | ㉓ Sleeve | ㉘ Retainer spring |
| ⑩ Plug | ㉔ Retainer plate | ㉙ Retainer plate |
| ⑪ Shift valve B | ㉕ Return spring | |

SAT429I

REPAIR FOR COMPONENT PARTS

Control Valve Lower Body (Cont'd)

DISASSEMBLY

- Remove valves at retainer plate.
For removal procedures, refer to "DISASSEMBLY", "Control Valve Upper Body", AT-244.

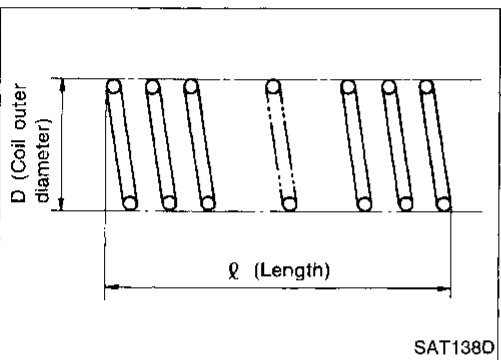
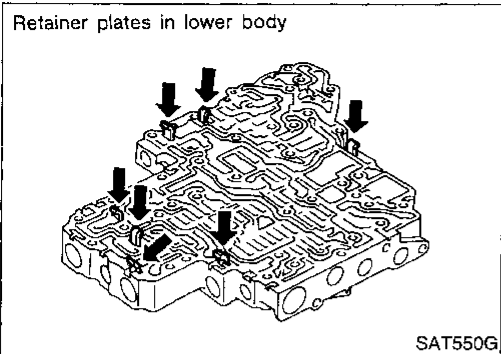

INSPECTION

Valve springs

- Check each valve spring for damage or deformation. Also measure free length and outer diameter.

Inspection standard:

Refer to SDS, AT-302.

- Replace valve springs if deformed or fatigued.

Control valves

- Check sliding surfaces of control valves, sleeves and plugs for damage.

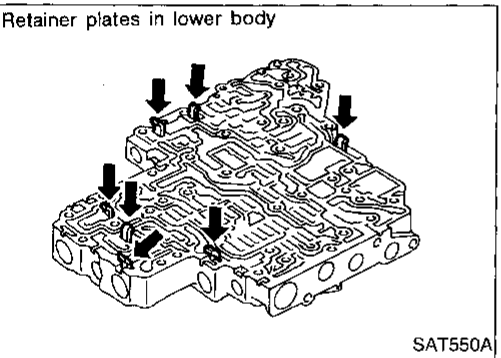

ASSEMBLY

- Install control valves.
For installation procedures, refer to "ASSEMBLY", "Control Valve Upper Body", AT-245.

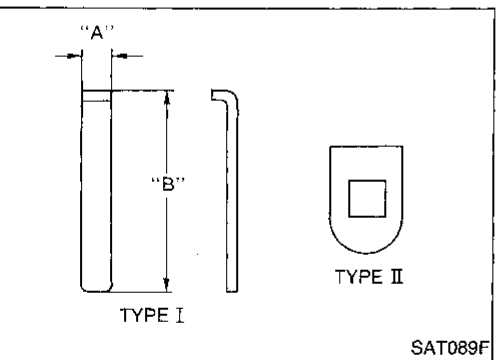

Retainer plate

Unit: mm (in)

Name of control valve and plug	Length A	Length B	Type
Plug	6.0 (0.236)	19.5 (0.768)	I
Pressure regulator valve			
Accumulator control valve			
Shift valve A			
Overrun clutch control valve			
Pressure modifier valve			
Shift valve B	—	—	II

- Install proper retainer plates.

Reverse Clutch

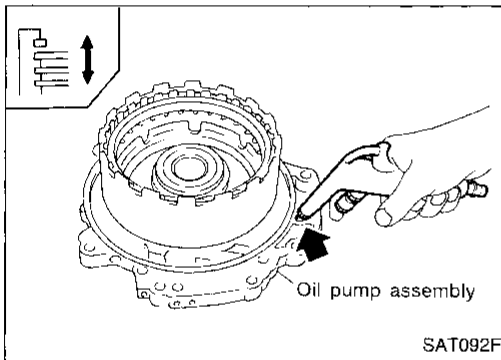
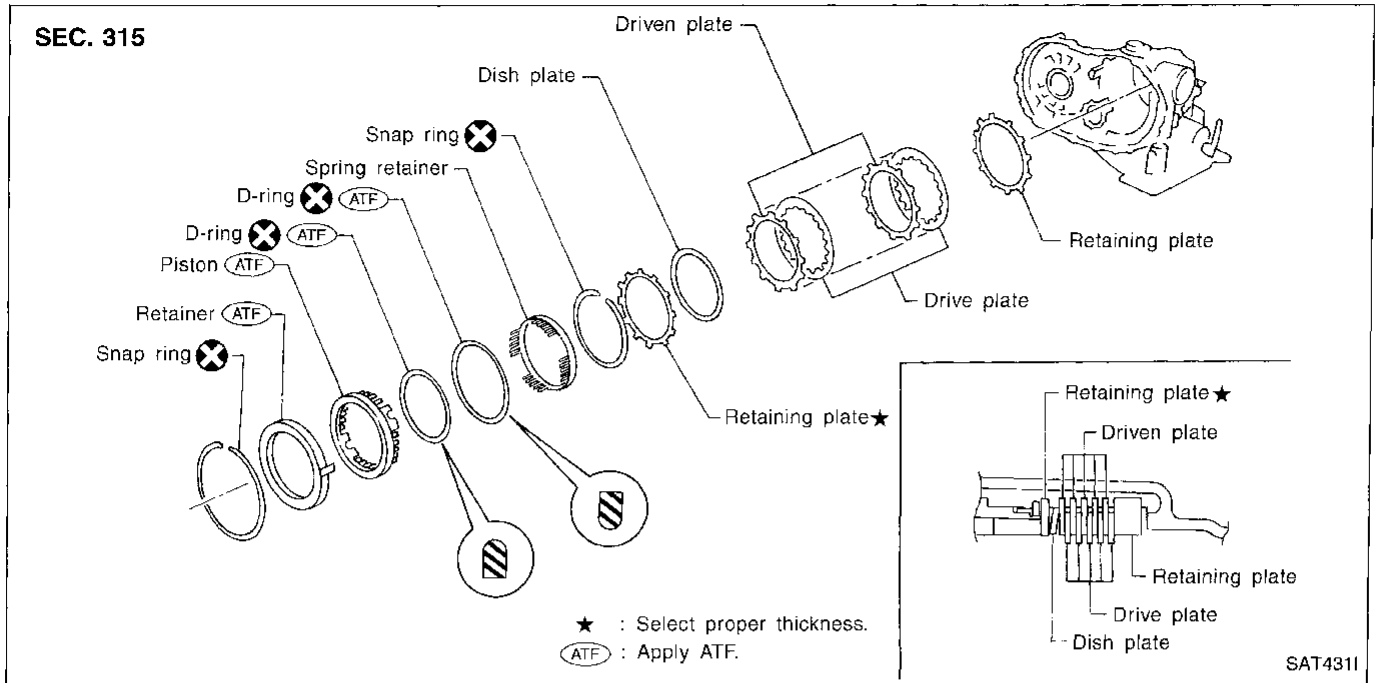

DISASSEMBLY

1. Check operation of reverse clutch
 - a. Install seal ring onto drum support of oil pump cover and install reverse clutch assembly. Apply compressed air to oil hole.
 - b. Check to see that retaining plate moves to snap ring.
 - c. If retaining plate does not contact snap ring:
 - D-ring might be damaged.
 - Oil seal might be damaged.
 - Fluid might be leaking past piston check ball.
2. Remove snap ring.
3. Remove drive plates, driven plates, retaining plate, and dish plates.

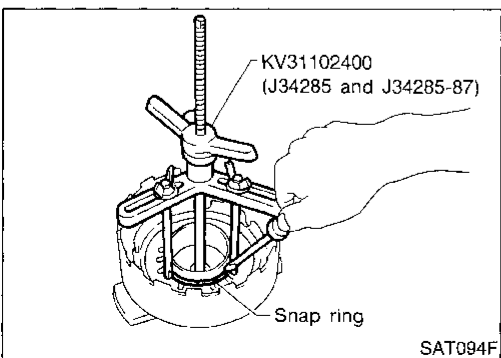
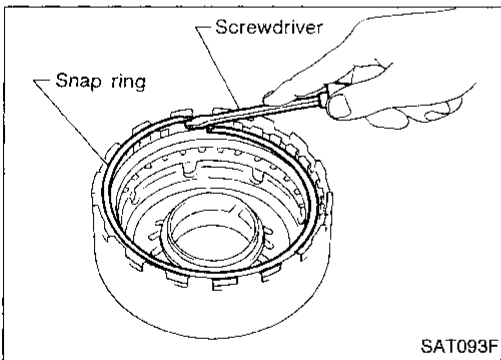

4. Set Tool on spring retainer and remove snap ring from reverse clutch drum while compressing return springs.
 - **Set Tool directly over springs.**
 - **Do not expand snap ring excessively.**
5. Remove spring retainer and return springs.

REPAIR FOR COMPONENT PARTS

Reverse Clutch (Cont'd)

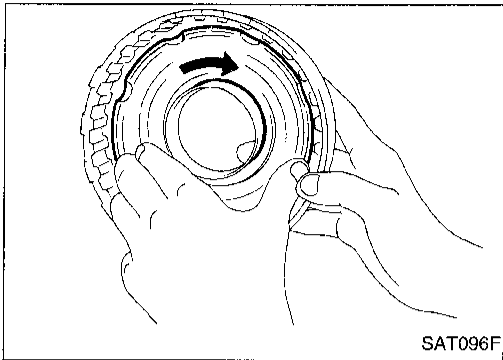

6. Remove piston from reverse clutch drum by turning it.
7. Remove D-ring and lip seal from piston.

INSPECTION

Reverse clutch snap ring, spring retainer and return springs

- Check for deformation, fatigue or damage. If necessary, replace.

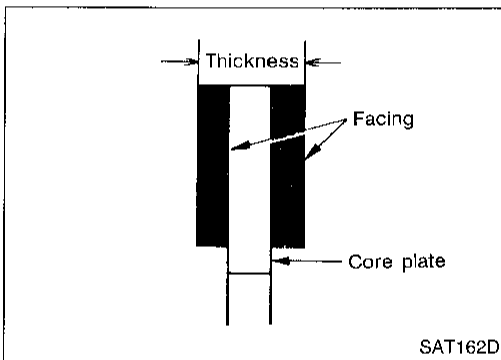

Reverse clutch drive plates

- Check facing for burns, cracks or damage.
- Measure thickness of facing.
Thickness of drive plate:
Standard value: 1.6 mm (0.063 in)
Wear limit: 1.4 mm (0.055 in)
- If not within wear limit, replace.

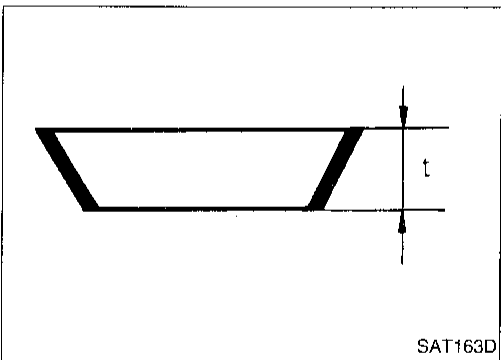

Reverse clutch dish plates

- Check for deformation or damage.
- Measure thickness of dish plate.
Thickness of dish plate: 3.08 mm (0.1213 in)
- If deformed or fatigued, replace.

Reverse clutch piston

- Make sure that check balls are not fixed.
- Apply compressed air to check ball oil hole opposite the return spring. Make sure there is no air leakage.
- Apply compressed air to oil hole on return spring side to make sure that air leaks past ball.

ASSEMBLY

1. Install D-ring and lip seal on piston.
- **Take care with the direction of lip seal.**
 - **Apply ATF to both parts.**

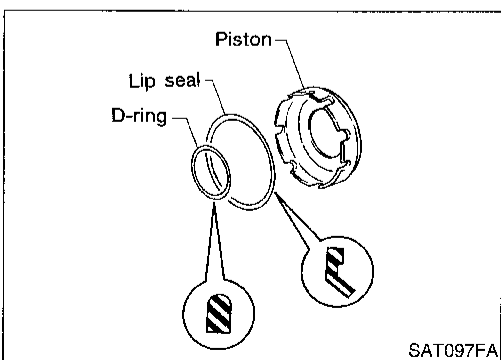

REPAIR FOR COMPONENT PARTS

Reverse Clutch (Cont'd)

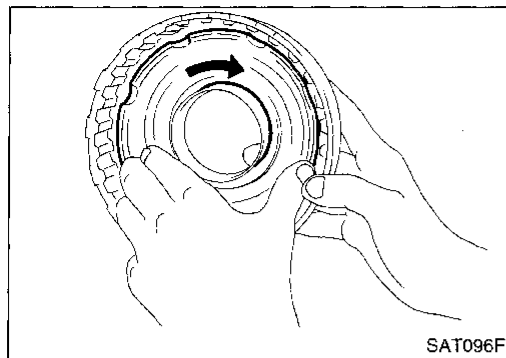

2. Install piston assembly by turning it slowly.
 - **Apply ATF to inner surface of drum.**

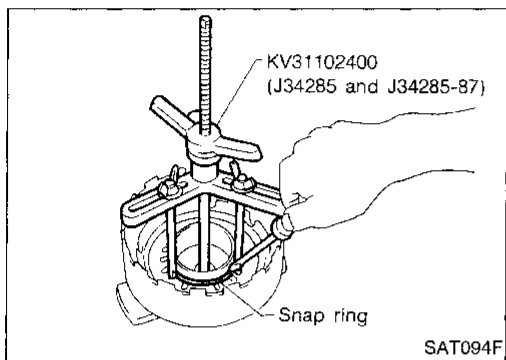

3. Install return springs and spring retainer on piston.
4. Set Tool on spring retainer and install snap ring while compressing return springs.
 - **Set Tool directly over return springs.**

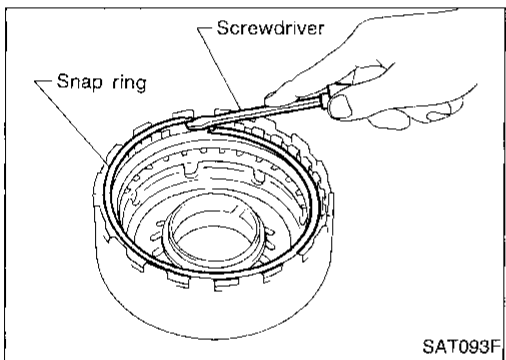

5. Install drive plates, driven plates, retaining plate and dish plates.
 - **Take care with order of plates.**
6. Install snap ring.

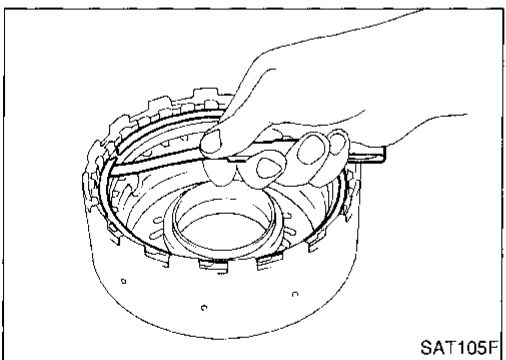

7. Measure clearance between retaining plate and snap ring. If not within allowable limit, select proper retaining plate.
 - Specified clearance:**
 - Standard 0.5 - 0.8 mm (0.020 - 0.031 in)**
 - Allowable limit 1.2 mm (0.047 in)**
 - Retaining plate:**
 - Refer to SDS, AT-303.**

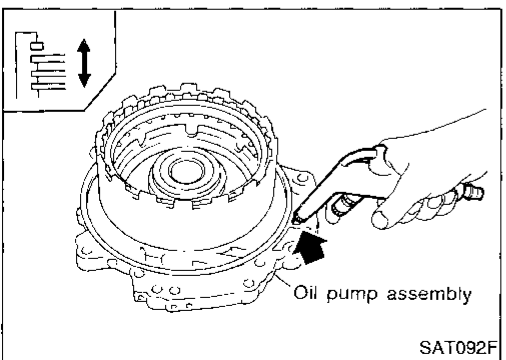

8. Check operation of reverse clutch.
 - Refer to "DISASSEMBLY", "Reverse Clutch", AT-249.

GI

MA

EM

LC

EC

FE

CL

MT

AT

FA

RA

BR

ST

RS

BT

HA

EL

IDX

High Clutch

SEC. 315

A

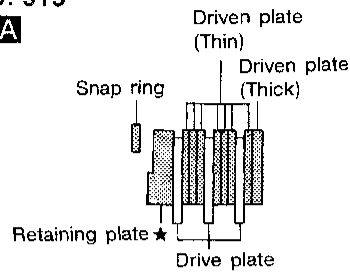

For the number of clutch plates (drive and driven plates), refer to the cross-section.

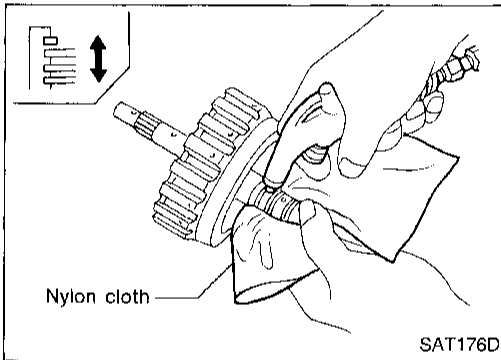
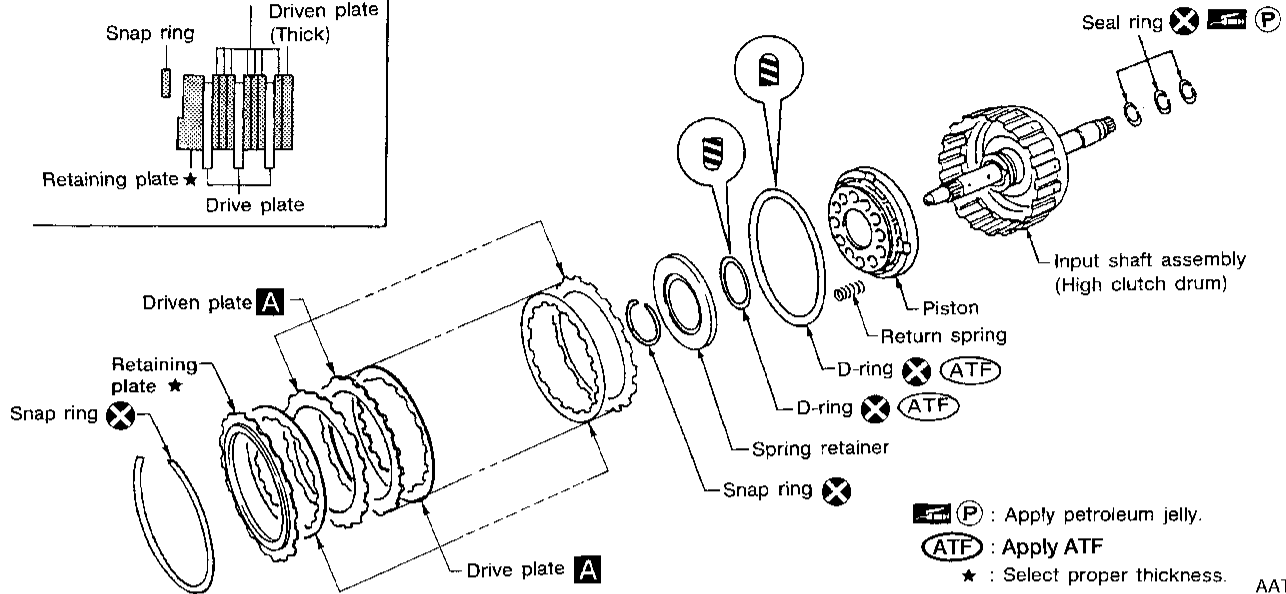

DISASSEMBLY

1. Check operation of high clutch.
 - a. Apply compressed air to oil hole of input shaft with nylon cloth.
 - **Stop up hole on opposite side of input shaft with nylon cloth.**
 - b. Check to see that retaining plate moves to snap ring.
 - c. If retaining plate does not contact snap ring:
 - D-ring might be damaged.
 - Oil seal might be damaged.
 - Fluid might be leaking past piston check ball.
2. Remove seal rings from input shaft.
 - **Always replace when removed.**

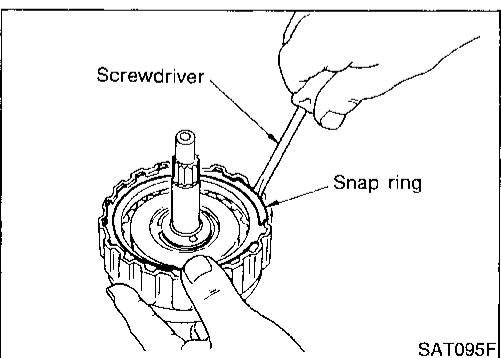
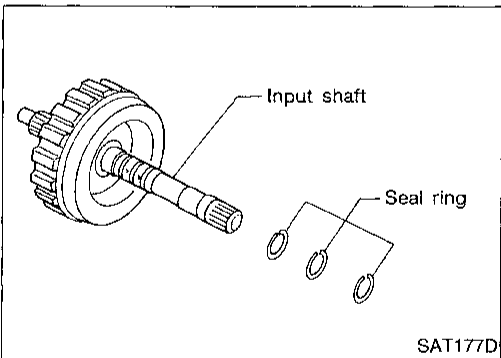

3. Remove snap ring.
4. Remove drive plates, driven plates and retaining plate.

REPAIR FOR COMPONENT PARTS

High Clutch (Cont'd)

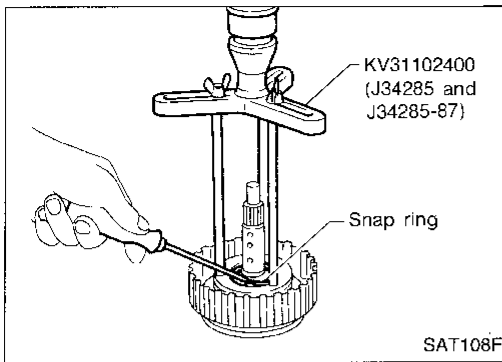

5. Set Tool on spring retainer and remove snap ring from high clutch drum while compressing return springs.

- **Set Tool directly over springs.**
- **Do not expand snap ring excessively.**

6. Remove spring retainer and return springs.

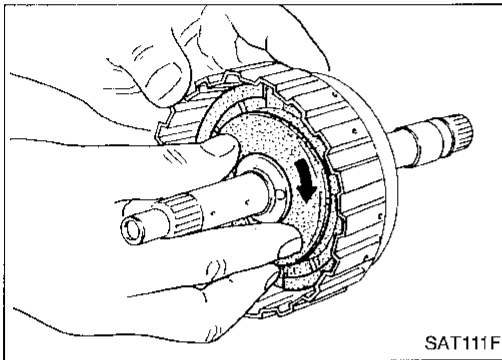

7. Remove piston from high clutch drum by turning it.

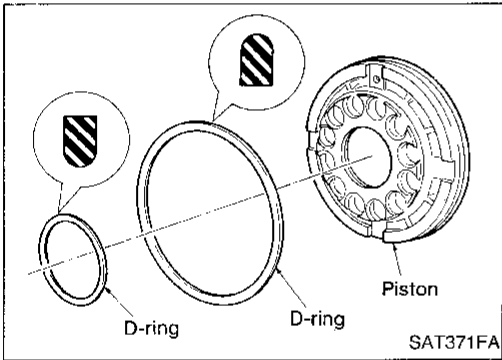

8. Remove D-rings from piston.

INSPECTION

High clutch snap ring, spring retainer and return springs

- Check for deformation, fatigue or damage. If necessary, replace.
- **When replacing spring retainer and return springs, replace them as a set.**

High clutch drive plates

- Check facing for burns, cracks or damage.
- Measure thickness of facing.
Thickness of drive plate:
Standard value 1.6 mm (0.063 in)
Wear limit 1.4 mm (0.055 in)
- If not within wear limit, replace.

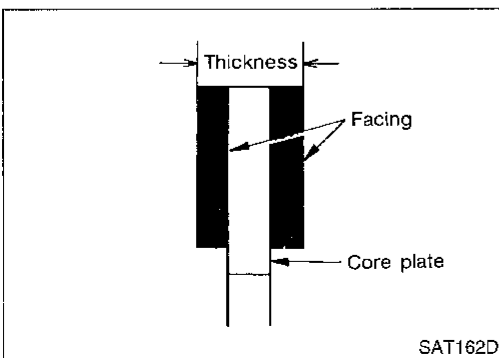

GI

MA

EM

LC

EC

FE

CL

MT

AT

FA

FA

BR

ST

RS

BT

HA

EL

IDX

REPAIR FOR COMPONENT PARTS

High Clutch (Cont'd)

High clutch piston

- Make sure that check balls are not fixed.
- Apply compressed air to check ball oil hole opposite the return spring. Make sure there is no air leakage.
- Apply compressed air to oil hole on return spring side to make sure that air leaks past ball.

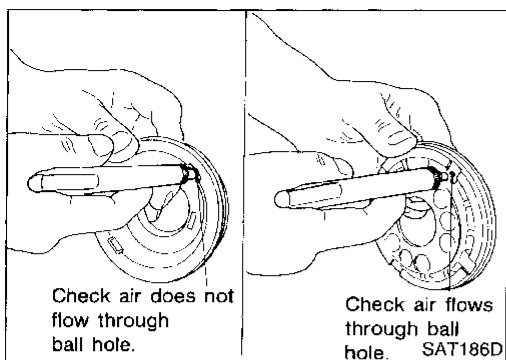

Seal ring clearance

- Install new seal rings onto input shaft.
- Measure clearance between seal ring and ring groove.
Standard clearance:
0.08 - 0.23 mm (0.0031 - 0.0091 in)
Allowable limit:
0.23 mm (0.0091 in)
- If not within allowable limit, replace input shaft assembly.

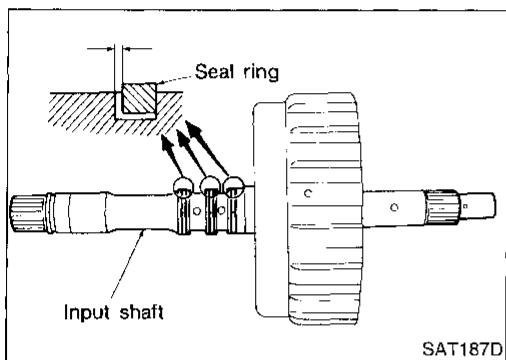

ASSEMBLY

1. Install D-rings on piston.
- **Apply ATF to both parts.**

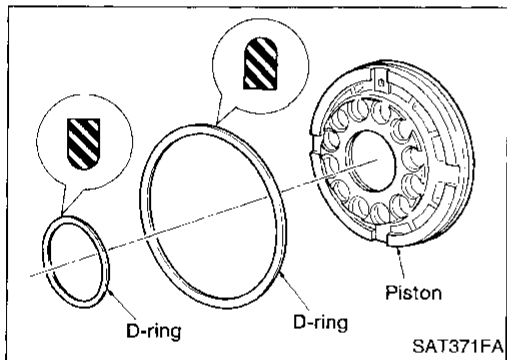

2. Install piston assembly by turning it slowly.
- **Apply ATF to inner surface of drum.**

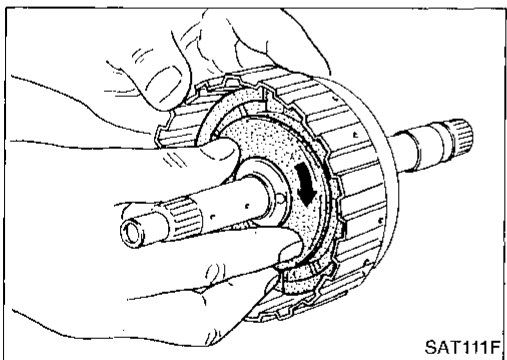

3. Install return springs and spring retainer on piston.

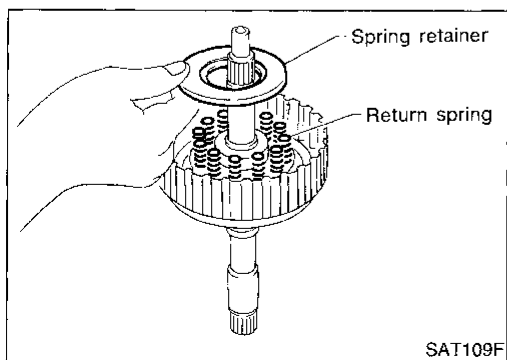

REPAIR FOR COMPONENT PARTS

High Clutch (Cont'd)

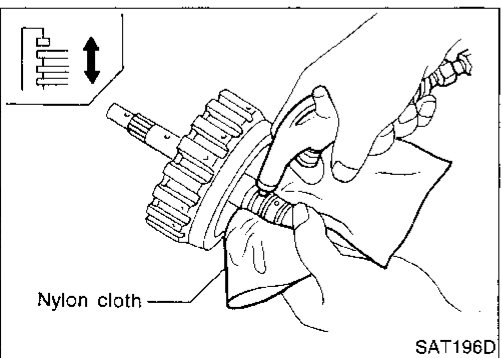
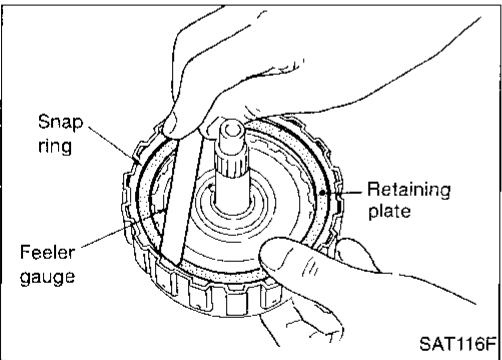
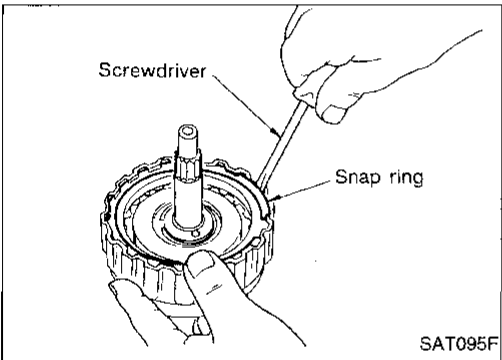
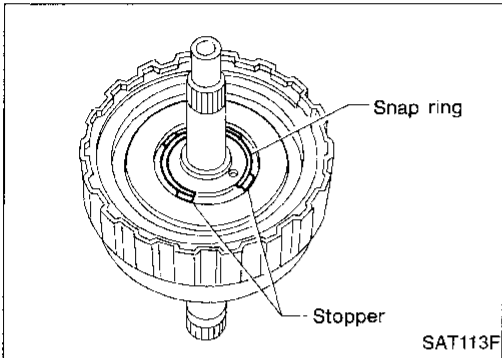
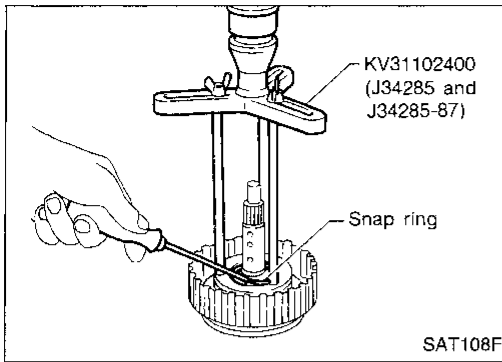

4. Set Tool on spring retainer and install snap ring while compressing return springs.

- **Set Tool directly over return springs.**

- **Do not align snap ring gap with spring retainer stopper.**

5. Install drive plates, driven plates and retaining plate.

- **Take care with the order and direction of plates.**

6. Install snap ring.

7. Measure clearance between retaining plate and snap ring. If not within allowable limit, select proper retaining plate.

Specified clearance:

Standard 1.8 - 2.2 mm (0.071 - 0.087 in)

Allowable limit 2.8 mm (0.110 in)

Retaining plate:

Refer to SDS, AT-303.

8. Check operation of high clutch.

Refer to "DISASSEMBLY", "High Clutch", AT-252.

GI

MA

EM

LC

EC

FE

CL

MT

AT

FA

RA

BR

ST

RS

BT

HA

EL

IDX

REPAIR FOR COMPONENT PARTS

High Clutch (Cont'd)

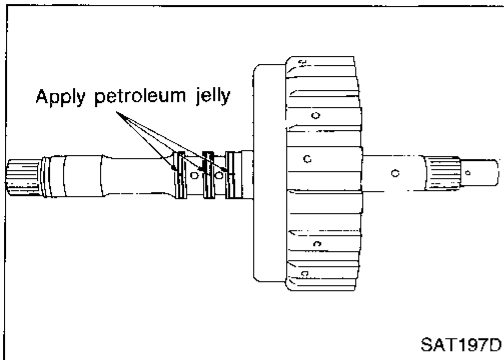

9. Install seal rings to input shaft.
- Apply petroleum jelly to seal rings.
 - Always replace when removed.

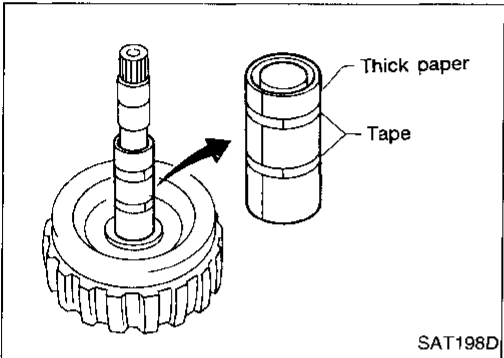

- Roll paper around seal rings to prevent seal rings from spreading.

Forward Clutch and Overrun Clutch

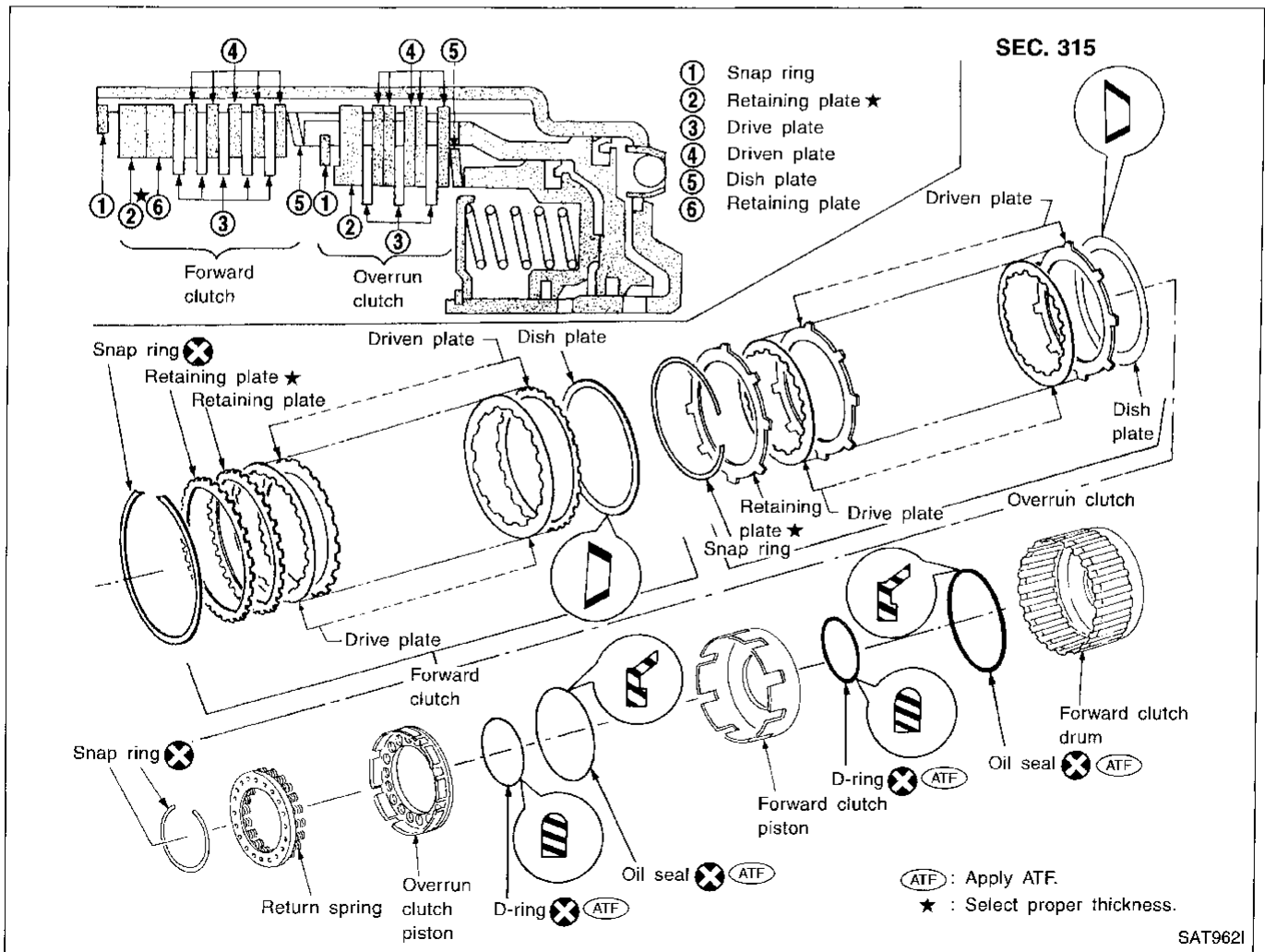

REPAIR FOR COMPONENT PARTS

Forward Clutch and Overrun Clutch (Cont'd) DISASSEMBLY

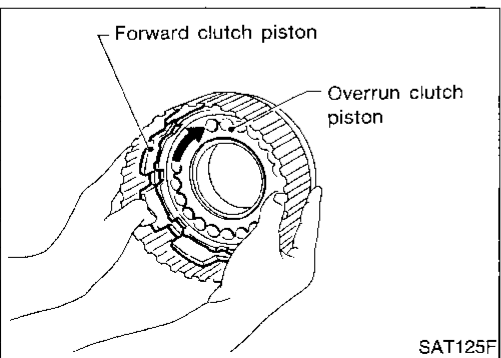
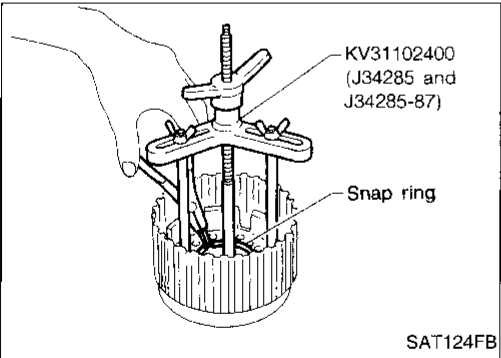
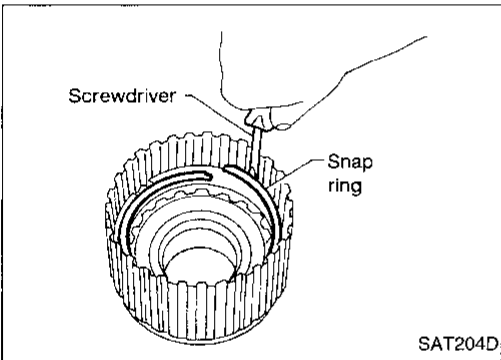
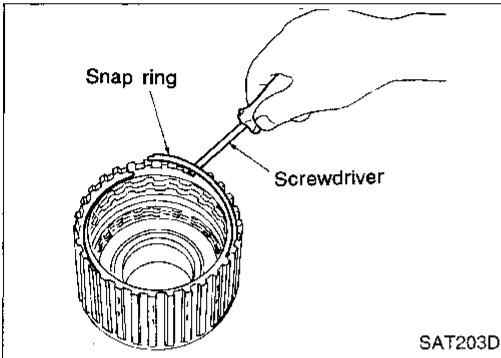
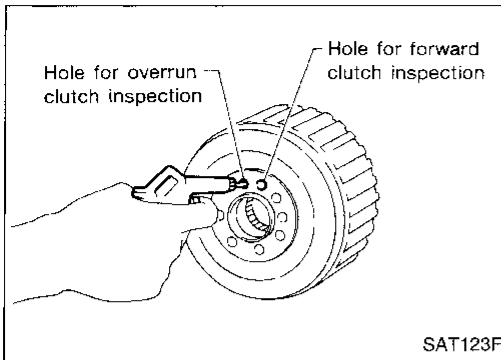

1. Check operation of forward clutch and overrun clutch.
 - a. Install bearing retainer on forward clutch drum.
 - b. Apply compressed air to oil hole of forward clutch drum.
 - c. Check to see that retaining plate moves to snap ring.
 - d. If retaining plate does not contact snap ring:
 - D-ring might be damaged.
 - Oil seal might be damaged.
 - Fluid might be leaking past piston check ball.
2. Remove snap ring for forward clutch.
3. Remove drive plates, driven plates, retaining plate and dish plate for forward clutch.
4. Remove snap ring for overrun clutch.
5. Remove drive plates, driven plates, retaining plate and dish plate for overrun clutch.
6. Set Tool on spring retainer and remove snap ring from forward clutch drum while compressing return springs.
 - **Set Tool directly over return springs.**
 - **Do not expand snap ring excessively.**
7. Remove spring retainer and return springs.
 - **Do not remove return springs from spring retainer.**
8. Remove forward clutch piston with overrun clutch piston from forward clutch drum by turning it.

GI

MA

EM

LC

EC

FE

CL

MT

AT

FA

RA

BR

ST

RS

BT

HA

EL

IDX

REPAIR FOR COMPONENT PARTS

Forward Clutch and Overrun Clutch (Cont'd)

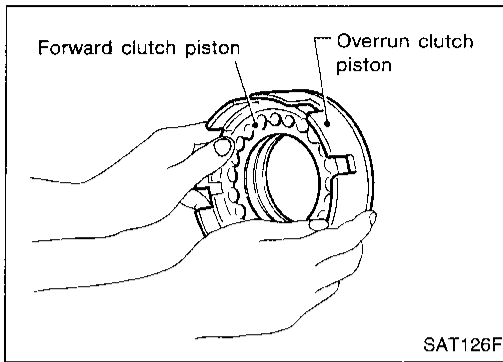

9. Remove overrun clutch piston from forward clutch piston by turning it.

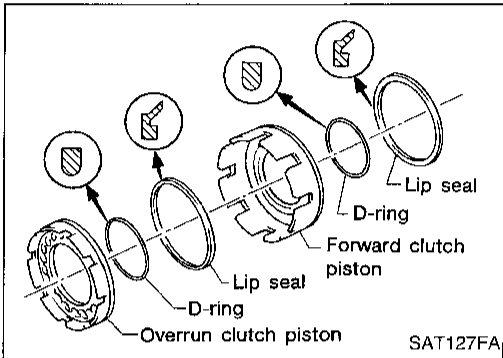

10. Remove D-rings and lip seals from forward clutch piston and overrun clutch piston.

INSPECTION

Snap rings, spring retainer and return springs

- Check for deformation, fatigue or damage.
- Replace if necessary.
- **When replacing spring retainer and return springs, replace them as a set.**

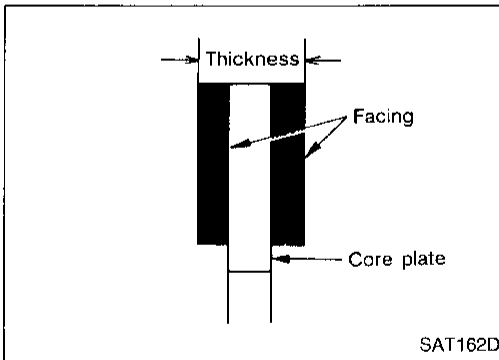

Forward clutch and overrun clutch drive plates

- Check facing for burns, cracks or damage.
- Measure thickness of facing.

Thickness of drive plate:

Forward clutch

Standard value: 1.6 mm (0.063 in)

Wear limit: 1.4 mm (0.055 in)

Overrun clutch

Standard value: 1.6 mm (0.063 in)

Wear limit: 1.4 mm (0.055 in)

- If not within wear limit, replace.

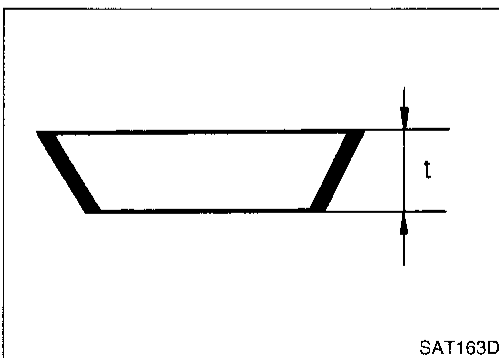

Forward clutch and overrun clutch dish plates

- Check for deformation or damage.
- Measure thickness of dish plate.

Thickness of dish plate:

Forward clutch 2.7 mm (0.106 in)

Overrun clutch 2.7 mm (0.106 in)

- If deformed or fatigued, replace.

REPAIR FOR COMPONENT PARTS

Forward Clutch and Overrun Clutch (Cont'd)

Forward clutch drum

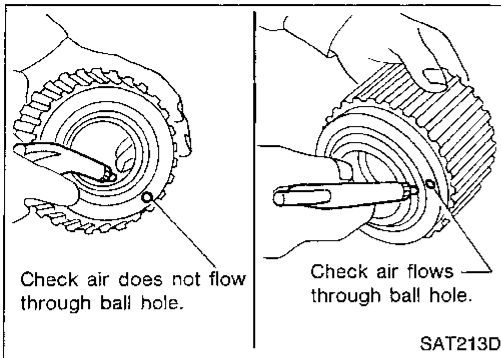

- Make sure that check balls are not fixed.
- Apply compressed air to check ball oil hole from outside of forward clutch drum. Make sure air leaks past ball.
- Apply compressed air to oil hole from inside of forward clutch drum. Make sure there is no air leakage.

GI
MA
EM

EM

LC

Overrun clutch piston

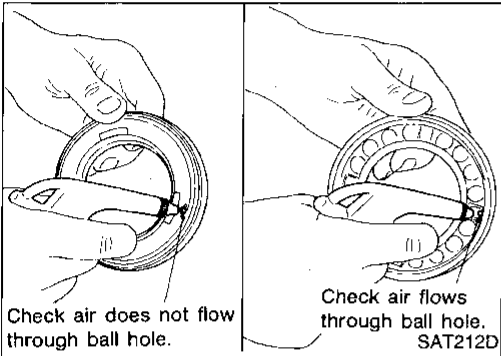

- Make sure that check balls are not fixed.
- Apply compressed air to check ball oil hole opposite the return spring. Make sure there is no air leakage.
- Apply compressed air to oil hole on return spring side. Make sure that air leaks past ball.

EC
FE
CL

CL

MT

ASSEMBLY

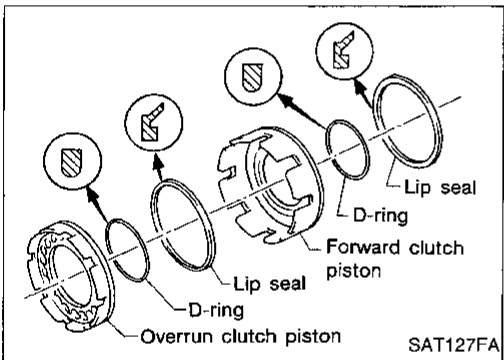

1. Install D-rings and lip seals on forward clutch piston and overrun clutch piston.
 - Take care with direction of lip seal.
 - Apply ATF to both parts.

AT

FA

RA

BR

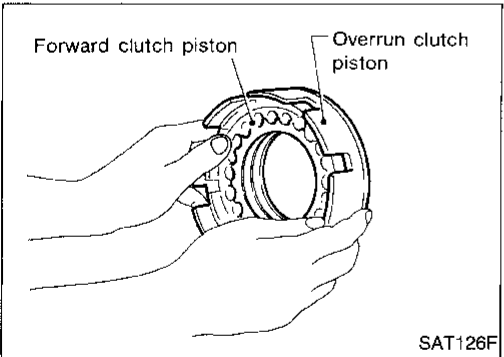

2. Install overrun clutch piston assembly on forward clutch piston by turning it slowly.
 - Apply ATF to inner surface of forward clutch piston.

ST

RS

BT

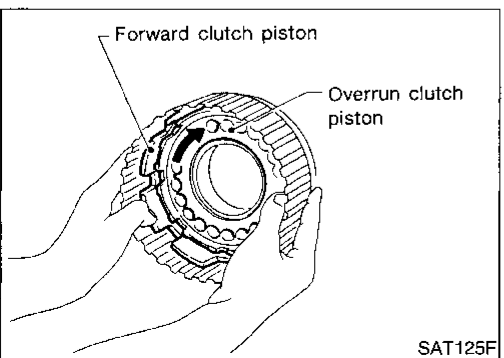

3. Install forward clutch piston assembly on forward clutch drum by turning it slowly.
 - Apply ATF to inner surface of drum.

HA

EL

IDX

REPAIR FOR COMPONENT PARTS

Forward Clutch and Overrun Clutch (Cont'd)

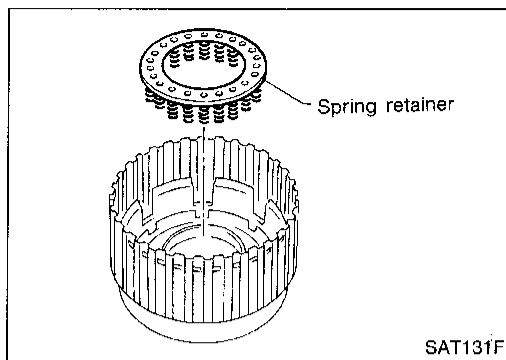

4. Install return spring on overrun clutch piston.

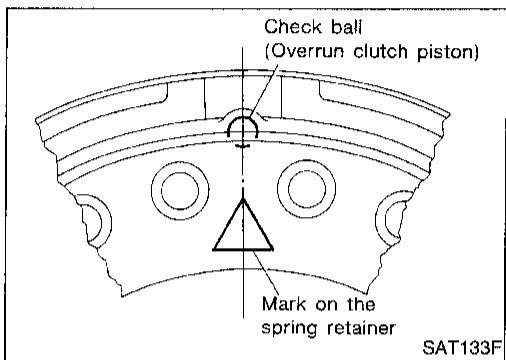

- Align the mark on spring retainer with check ball in overrun clutch piston.

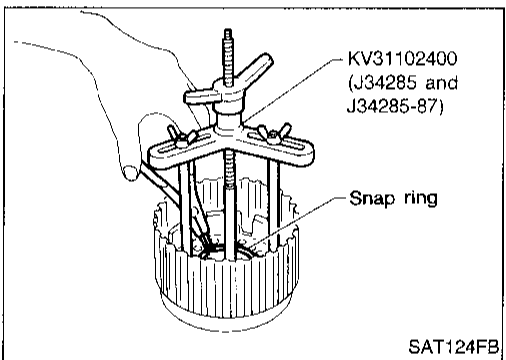

5. Set Tool on spring retainer and install snap ring while compressing return springs.

- **Set Tool directly over return springs.**

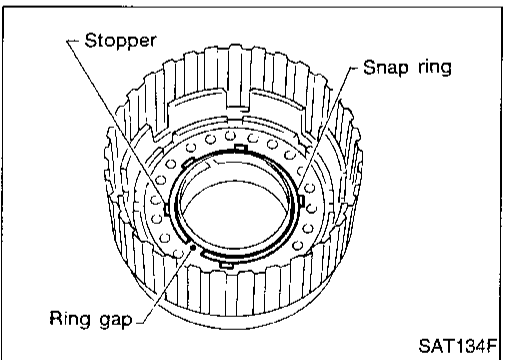

- **Do not align snap ring gap with spring retainer stopper.**

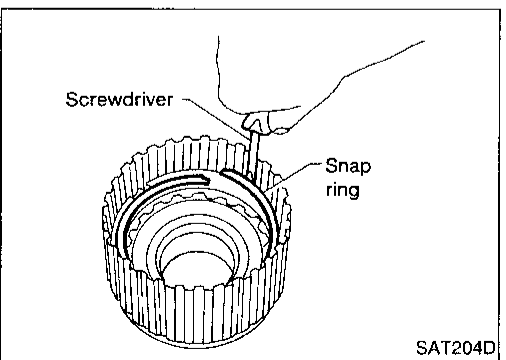

6. Install drive plates, driven plates, retaining plate and dish plate for overrun clutch.

- **Take care with order of plates.**

7. Install snap ring for overrun clutch.

REPAIR FOR COMPONENT PARTS

Forward Clutch and Overrun Clutch (Cont'd)

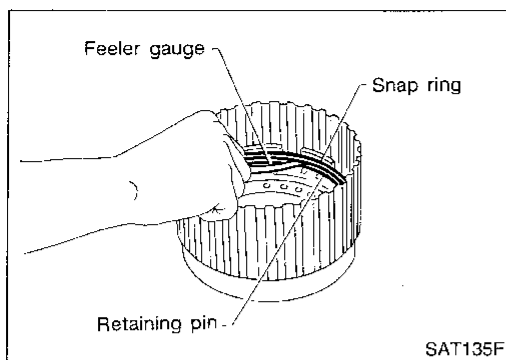

8. Measure clearance between overrun clutch retaining plate and snap ring.

If not within allowable limit, select proper retaining plate.

Specified clearance:

Standard 0.7 - 1.1 mm (0.028 - 0.043 in)

Allowable limit 1.7 mm (0.067 in)

Overrun clutch retaining plate:

Refer to SDS, AT-303.

GI

MA

EM

LG

EC

FE

CL

MT

AT

FA

RA

BR

ST

RS

BT

HA

EL

IDX

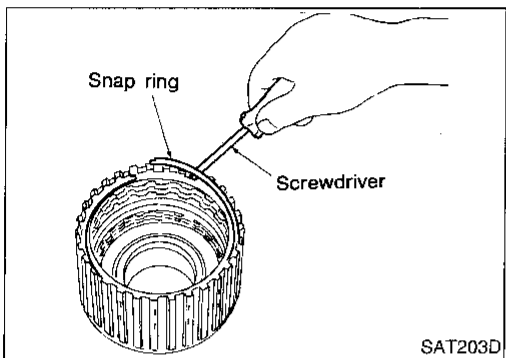

9. Install drive plates, driven plates, retaining plate and dish plate for forward clutch.

• **Take care with order of plates.**

10. Install snap ring for forward clutch.

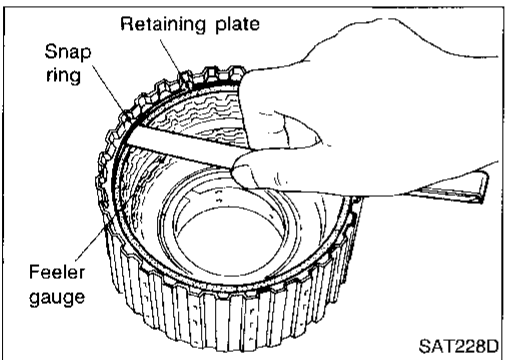

11. Measure clearance between forward clutch retaining plate and snap ring.

If not within allowable limit, select proper retaining plate.

Specified clearance:

Standard 0.45 - 0.85 mm (0.0177 - 0.0335 in)

Allowable limit 1.85 mm (0.0728 in)

Forward clutch retaining plate:

Refer to SDS, AT-303.

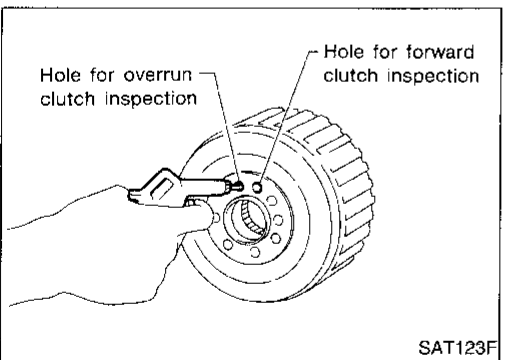

12. Check operation of forward clutch.

Refer to "DISASSEMBLY", "Forward Clutch and Overrun Clutch", AT-257.

13. Check operation of overrun clutch.

Refer to "DISASSEMBLY", "Forward Clutch and Overrun Clutch", AT-257.

Low & Reverse Brake

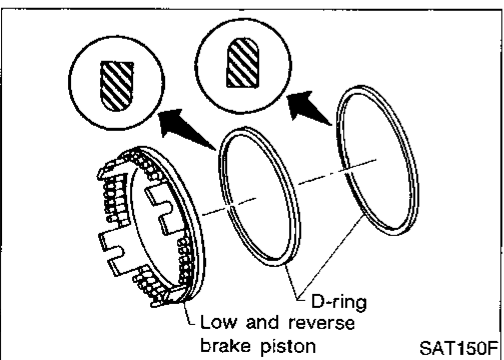
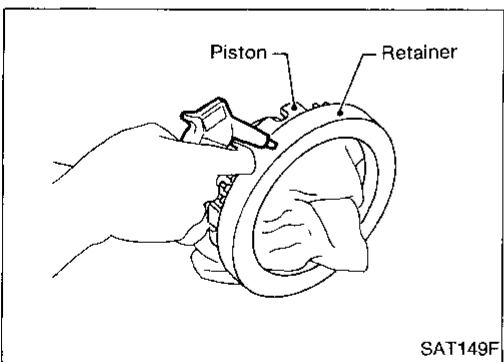
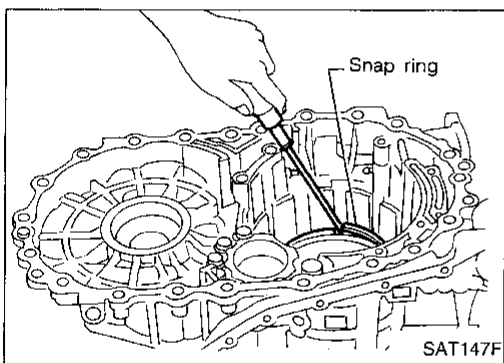
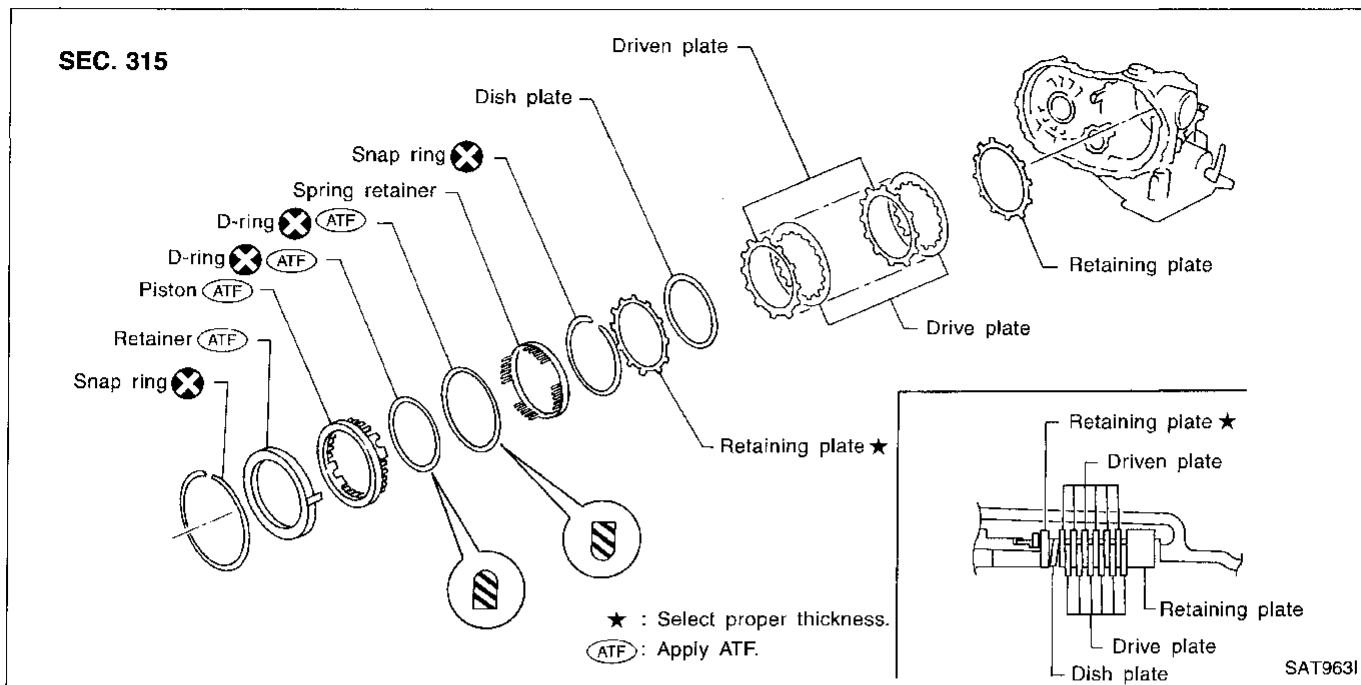

DISASSEMBLY

1. Check operation of low & reverse brake.
 - a. Apply compressed air to oil hole of transmission case.
 - b. Check to see that retaining plate moves to snap ring.
 - c. If retaining plate does not contact snap ring:
 - D-ring might be damaged.
 - Fluid might be leaking past piston check ball.

2. In order to remove piston, apply compressed air to oil hole of retainer while holding piston.
 - **Apply air gradually and allow piston to come out evenly.**

3. Remove D-rings from piston.

REPAIR FOR COMPONENT PARTS

Low & Reverse Brake (Cont'd)

INSPECTION

Low & reverse clutch snap ring, spring retainer and return springs

- Check for deformation, fatigue or damage. If necessary, replace.
- **When replacing spring retainer and return springs, replace them as a set.**

GI

MA

EM

LC

EC

FE

CL

MT

AT

FA

RA

BR

ST

RS

BT

HA

EL

IDX

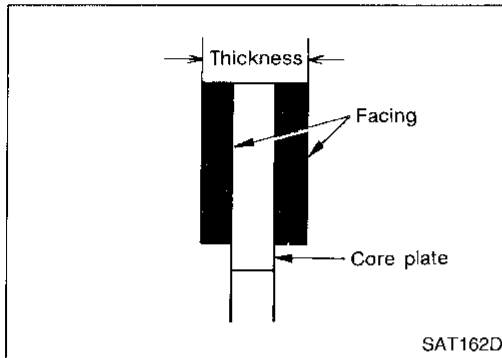

Low & reverse brake drive plate

- Check facing for burns, cracks or damage.
- Measure thickness of facing.

Thickness of drive plate:

Standard value 1.8 mm (0.071 in)

Wear limit 1.6 mm (0.063 in)

- If not within wear limit, replace.

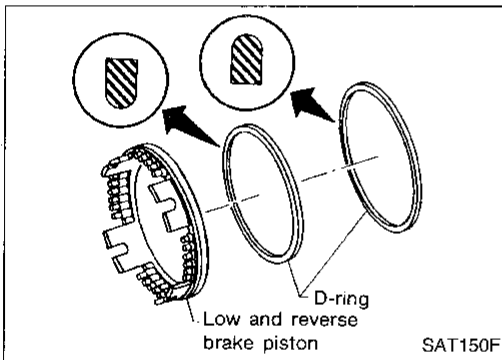

ASSEMBLY

1. Install D-rings on piston.
- **Apply ATF to both parts.**

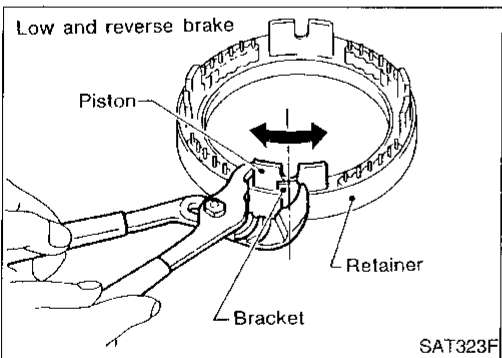

2. Set and align piston with retainer.

- **This operation is required in order to engage the protrusions of piston to return springs correctly. Further procedures are given in "ASSEMBLY".**

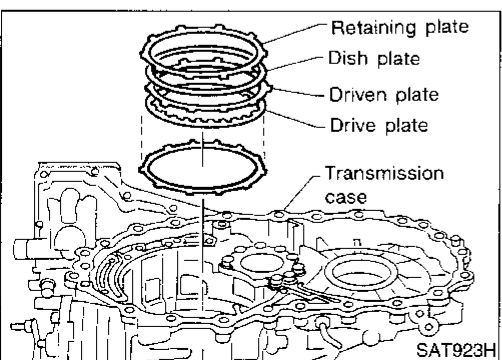

3. Install driven plates, drive plates, retaining plate and dish plate on transmission case.

- **Take care with order of plates and direction of dish plate.**

REPAIR FOR COMPONENT PARTS

Low & Reverse Brake (Cont'd)

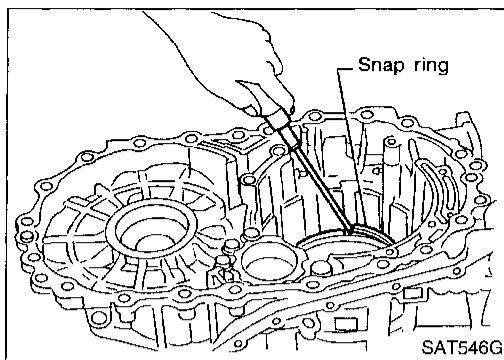

4. Install snap ring.

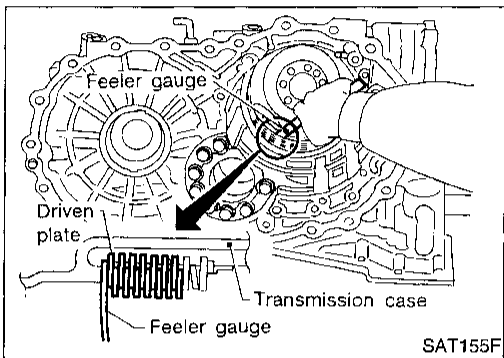

5. Measure clearance between driven plate and transmission case. If not within allowable limit, select proper retaining plate. (front side)

Specified clearance:

Standard 1.7 - 2.1 mm (0.067 - 0.083 in)

Allowable limit 3.3 mm (0.130 in)

Retaining plate:

Refer to SDS, AT-304.

Rear Internal Gear, Forward Clutch Hub and Overrun Clutch Hub

SEC. 315

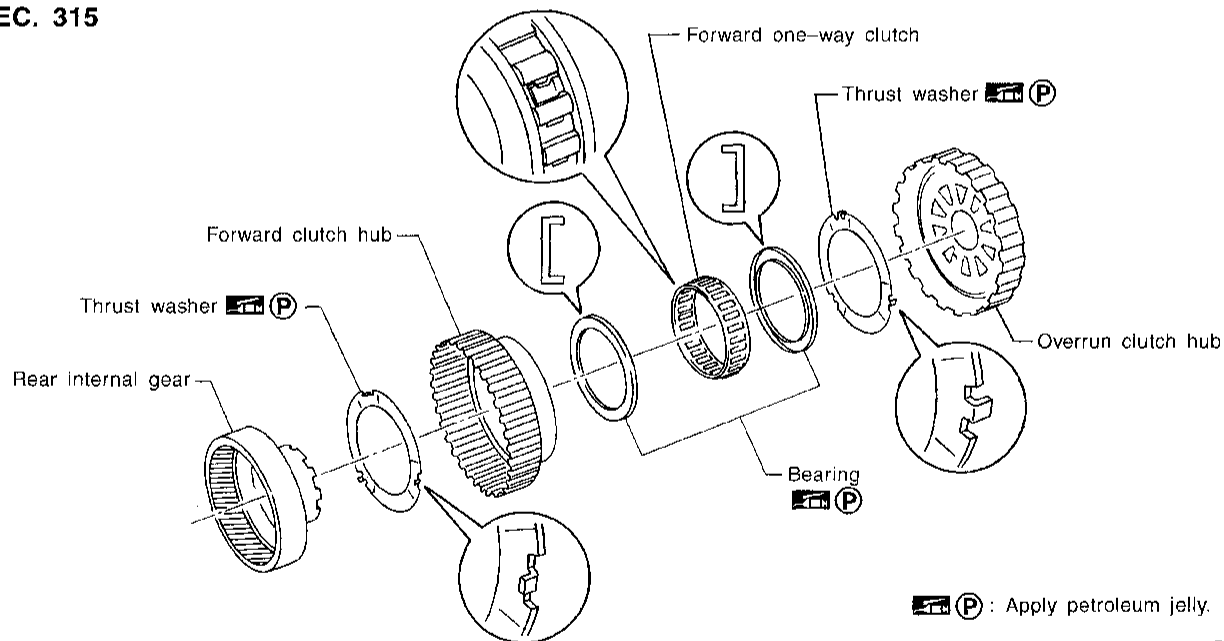

 (P) : Apply petroleum jelly.

SAT975H

REPAIR FOR COMPONENT PARTS

Rear Internal Gear, Forward Clutch Hub and Overrun Clutch Hub (Cont'd)

DISASSEMBLY

1. Remove overrun clutch hub and thrust washer from forward clutch hub. GI

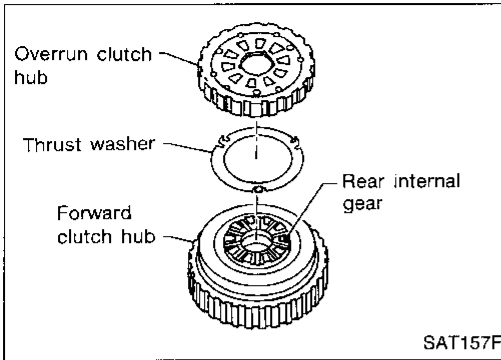

2. Remove forward clutch hub from rear internal gear. MA

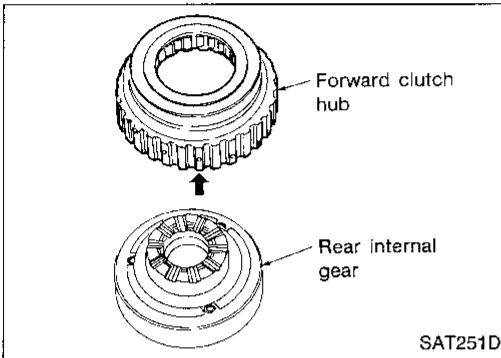

3. Remove bearing from rear internal gear. EM

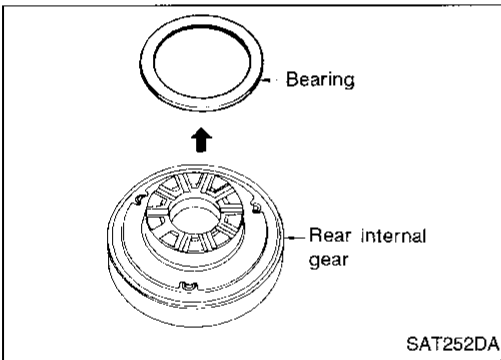

4. Remove thrust washer from rear internal gear. LC

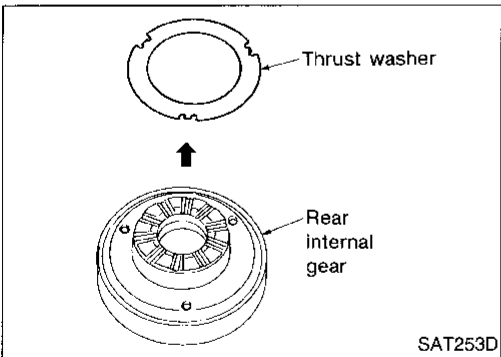

5. Remove bearing from forward one-way clutch. EC

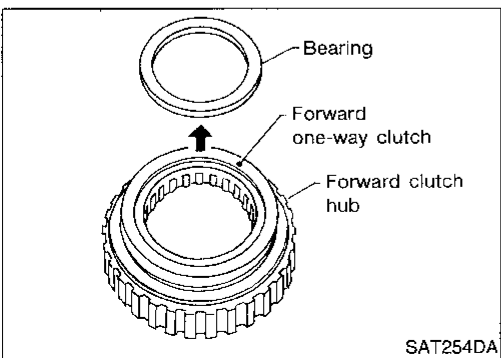

FE

CL

MT

AT

FA

RA

BR

ST

RS

BT

HA

EL

IDX

REPAIR FOR COMPONENT PARTS

Rear Internal Gear, Forward Clutch Hub and Overrun Clutch Hub (Cont'd)

6. Remove forward one-way clutch from forward clutch hub.

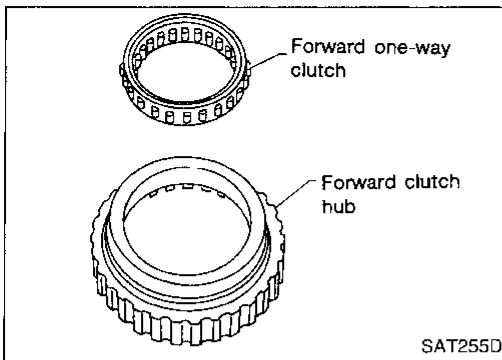

INSPECTION

Rear internal gear, forward clutch hub and overrun clutch hub

- Check rubbing surfaces for wear or damage.

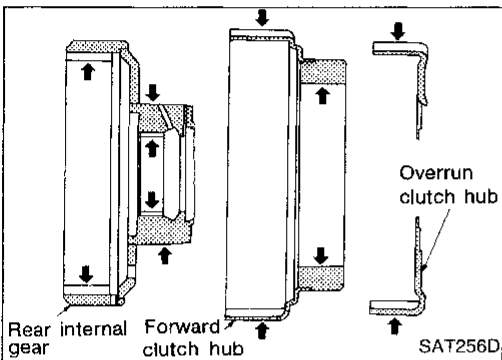

Bearings and forward one-way clutch

- Check bearings for deformation and damage.
- Check forward one-way clutch for wear and damage.

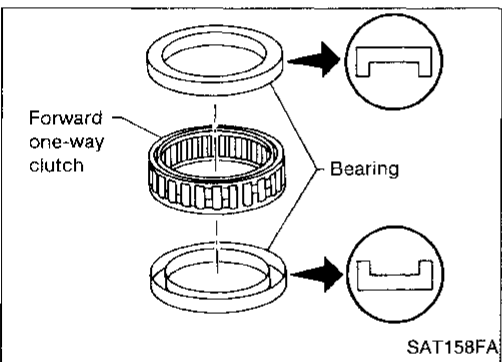

ASSEMBLY

1. Install forward one-way clutch on forward clutch.
 - Take care with the direction of forward one-way clutch.

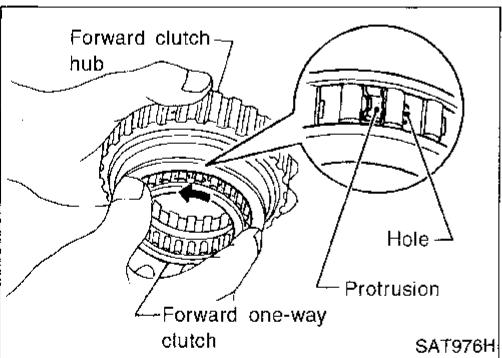

2. Install bearing on forward one-way clutch.
 - Apply petroleum jelly to bearing.

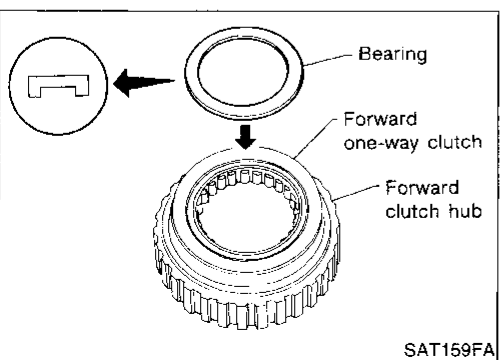

REPAIR FOR COMPONENT PARTS

Rear Internal Gear, Forward Clutch Hub and Overrun Clutch Hub (Cont'd)

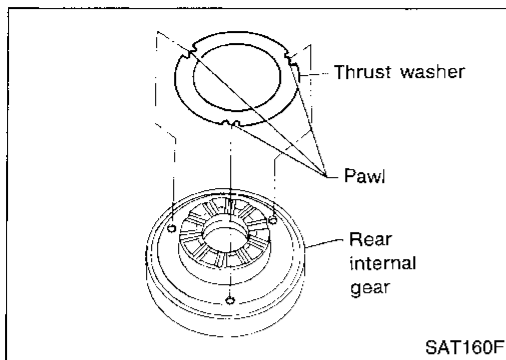

3. Install thrust washer on rear internal gear.
 - Apply petroleum jelly to thrust washer.
 - Align hooks of thrust washer with holes of rear internal gear.

GI

MA

EM

LG

EC

FE

CL

MT

AT

FA

RA

BR

ST

RS

BT

HA

EL

IDX

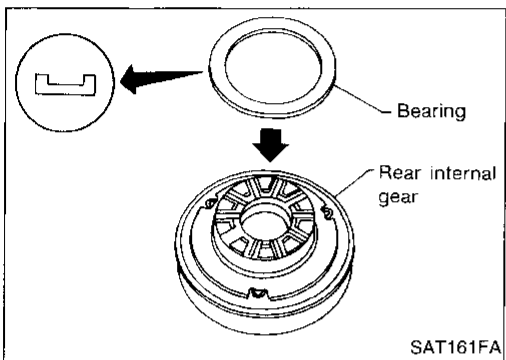

4. Install bearing on rear internal gear.
 - Apply petroleum jelly to bearing.

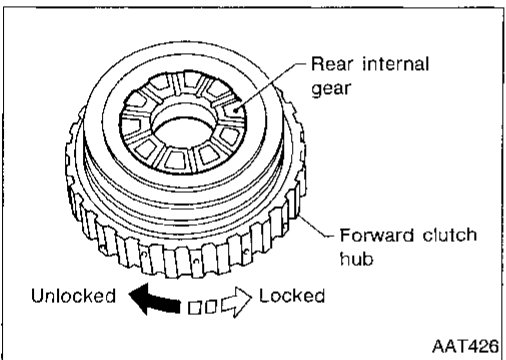

5. Install forward clutch hub on rear internal gear.
 - Check operation of forward one-way clutch. Hold rear internal gear and turn forward clutch hub. Check forward clutch hub for correct locking and unlocking directions.
 - If not as shown in illustration, check installation direction of forward one-way clutch.

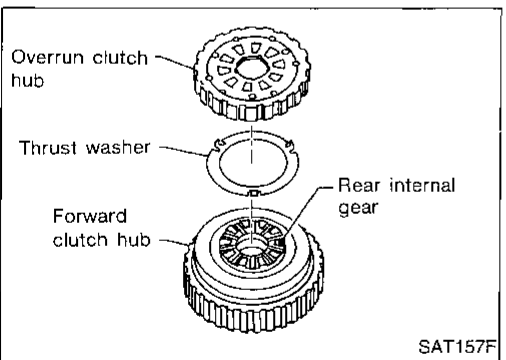

6. Install thrust washer and overrun clutch hub.
 - Apply petroleum jelly to thrust washer.
 - Align hooks of thrust washer with holes of overrun clutch hub.
 - Align projections of rear internal gear with holes of overrun clutch hub.

Output Shaft, Idler Gear, Reduction Pinion Gear and Bearing Retainer

SEC. 314

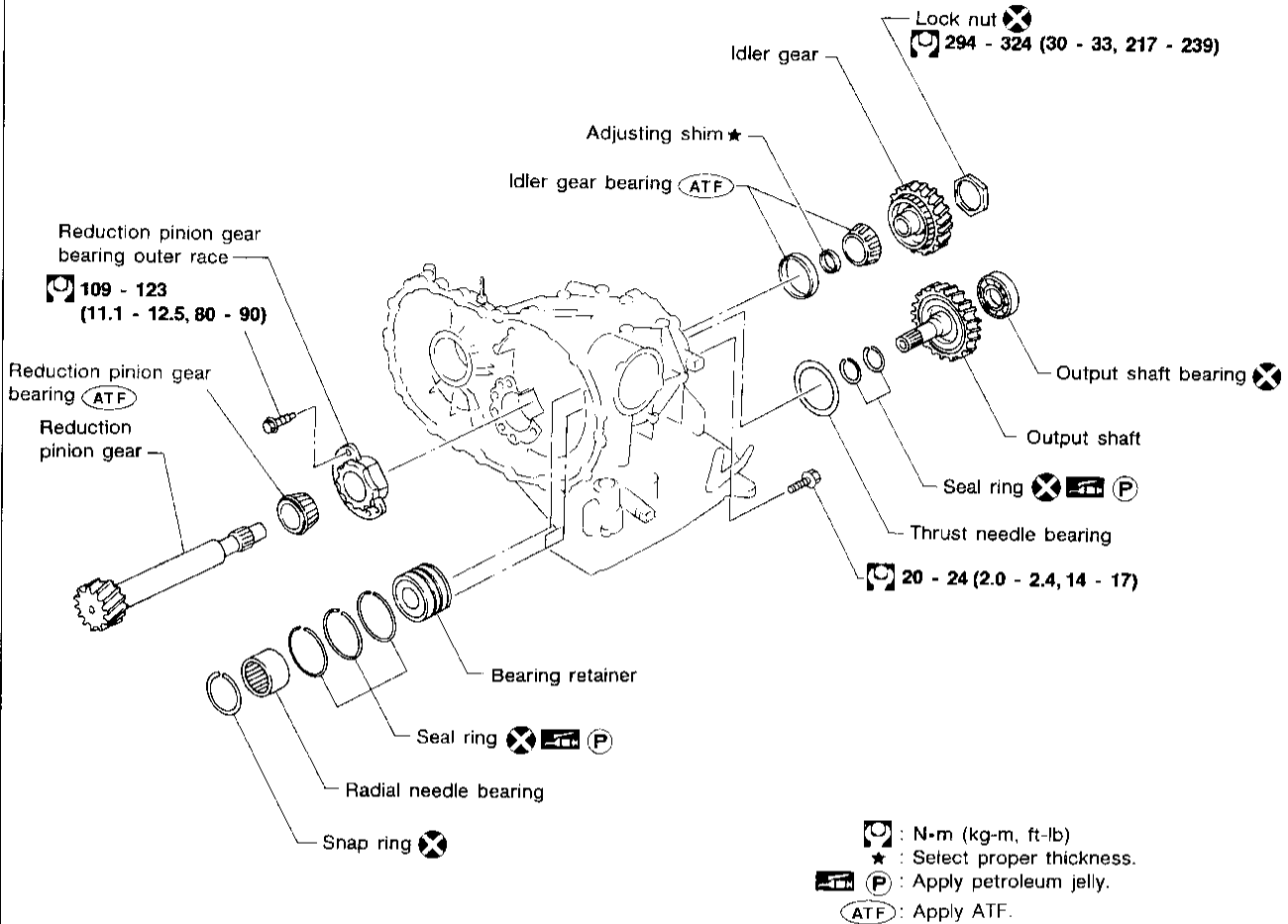

SAT557GB

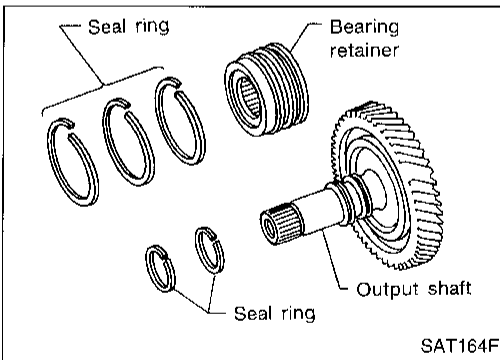

DISASSEMBLY

1. Remove seal rings from output shaft and bearing retainer.

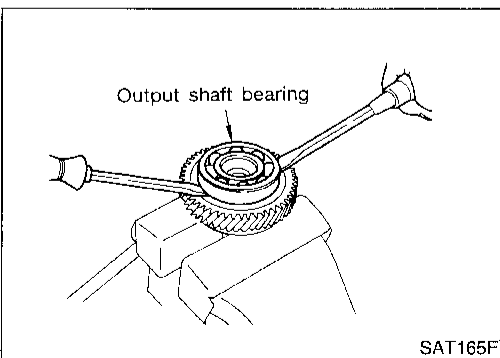

2. Remove output shaft bearing with screwdrivers.
- Always replace bearing with a new one when removed.
 - Do not damage output shaft.

REPAIR FOR COMPONENT PARTS

Output Shaft, Idler Gear, Reduction Pinion Gear and Bearing Retainer (Cont'd)

3. Remove snap ring from bearing retainer.

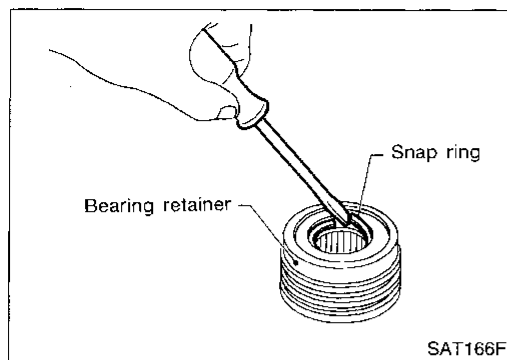

4. Remove needle bearing from bearing retainer.

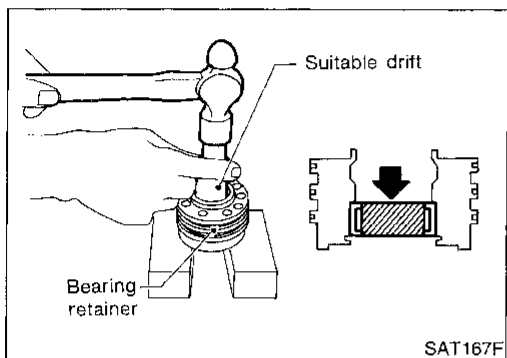

5. Remove idler gear bearing inner race from idler gear.

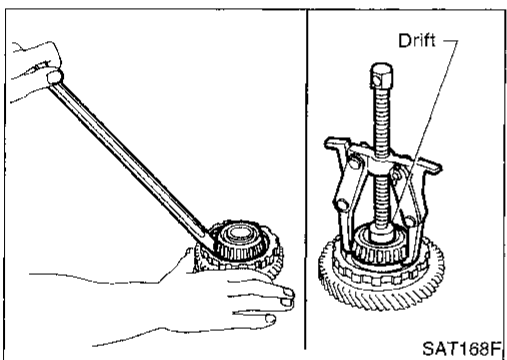

6. Remove idler gear bearing outer race from transmission case.

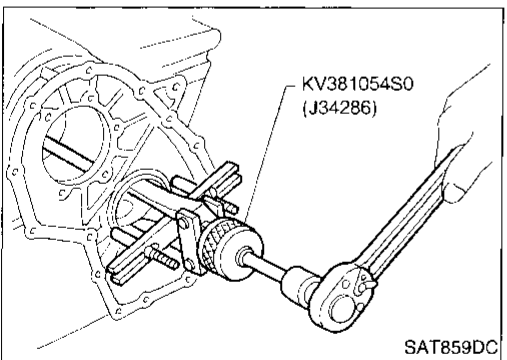

7. Press out reduction pinion gear bearing inner race from reduction pinion gear.

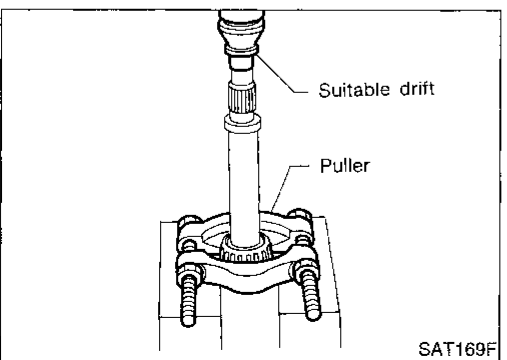

GI

MA

EM

LC

EC

FE

CL

MT

AT

FA

RA

BR

ST

RS

BT

HA

EL

IDX

REPAIR FOR COMPONENT PARTS

Output Shaft, Idler Gear, Reduction Pinion Gear and Bearing Retainer (Cont'd)

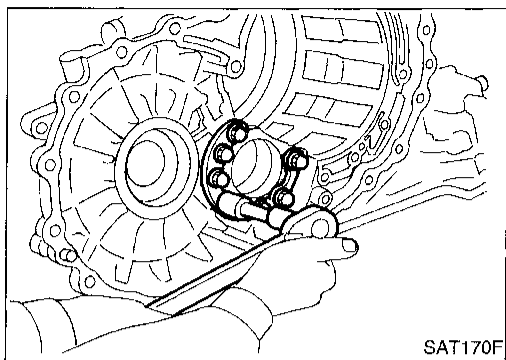

8. Remove reduction pinion gear bearing outer race from transmission case.

INSPECTION

Output shaft, idler gear and reduction pinion gear

- Check shafts for cracks, wear or bending.
- Check gears for wear, chips and cracks.

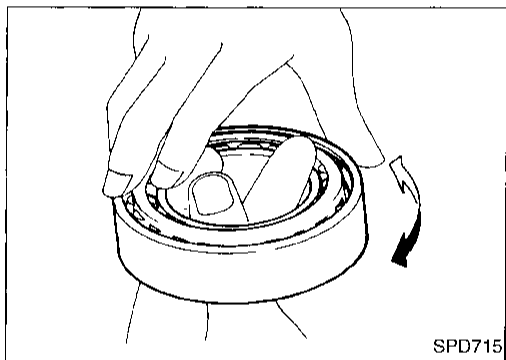

Bearing

- Make sure bearings roll freely and are free from noise, cracks, pitting or wear.
- **When replacing taper roller bearing, replace outer and inner race as a set.**

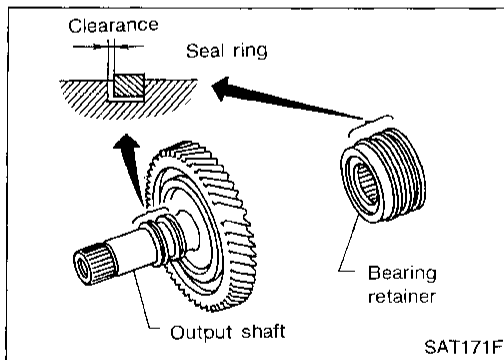

Seal ring clearance

- Install new seal rings to output shaft.
- Measure clearance between seal ring and ring groove of output shaft.

Standard clearance:

0.10 - 0.25 mm (0.0039 - 0.0098 in)

Allowable limit:

0.25 mm (0.0098 in)

- If not within allowable limit, replace output shaft.
- Install new seal rings to bearing retainer.
- Measure clearance between seal ring and ring groove of bearing retainer.

Standard clearance:

0.10 - 0.30 mm (0.0039 - 0.0118 in)

Allowable limit:

0.30 mm (0.0118 in)

- If not within allowable limit, replace bearing retainer.

REPAIR FOR COMPONENT PARTS

Output Shaft, Idler Gear, Reduction Pinion Gear and Bearing Retainer (Cont'd)

ASSEMBLY

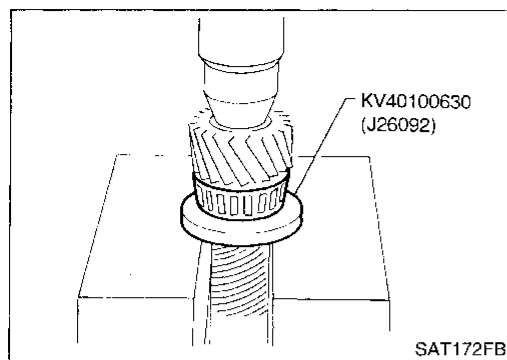

1. Press reduction pinion gear bearing inner race on reduction pinion gear.

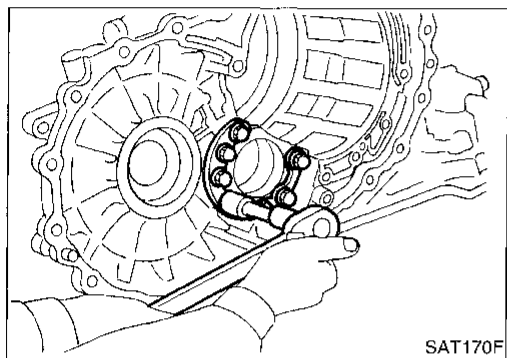

2. Install reduction pinion gear bearing outer race on transmission case.

 : 109 - 123 N·m (11.1 - 12.5 kg·m, 80 - 90 ft·lb)

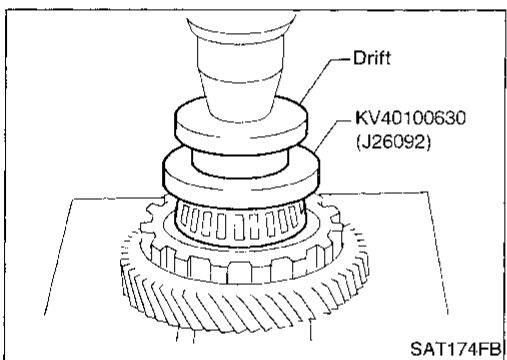

3. Press idler gear bearing inner race on idler gear.

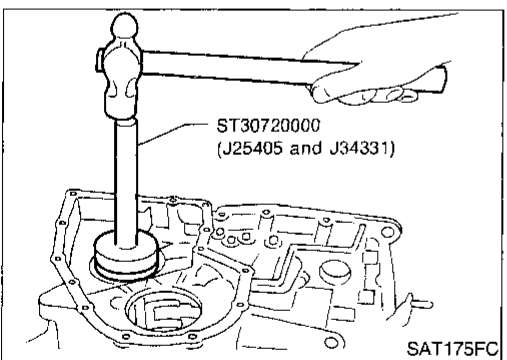

4. Install idler gear bearing outer race on transmission case.

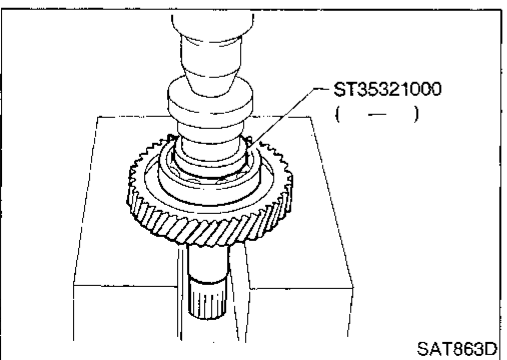

5. Press output shaft bearing on output shaft.

GI

MA

EM

LC

EC

FE

CL

WT

AT

FA

RA

BR

ST

RS

BT

HA

EL

IDX

REPAIR FOR COMPONENT PARTS

Output Shaft, Idler Gear, Reduction Pinion Gear and Bearing Retainer (Cont'd)

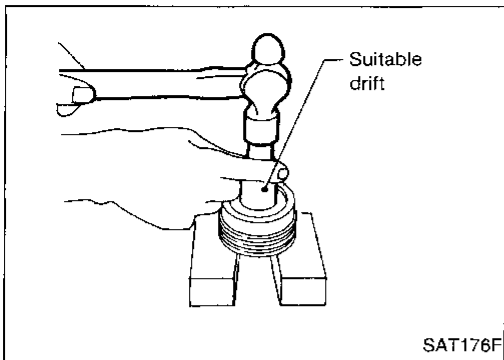

6. Press needle bearing on bearing retainer.

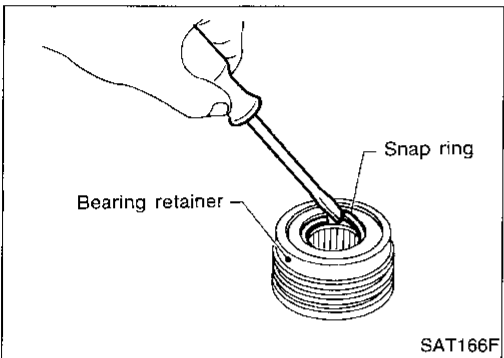

7. Install snap ring to bearing retainer.

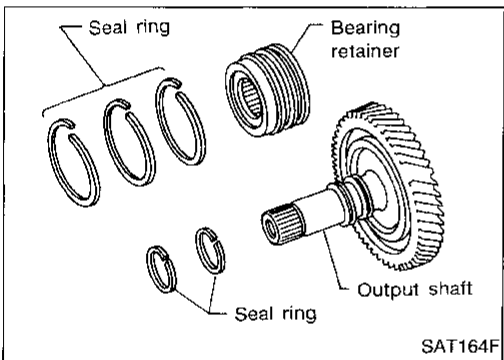

8. After packing ring grooves with petroleum jelly, carefully install new seal rings on output shaft and bearing retainer.

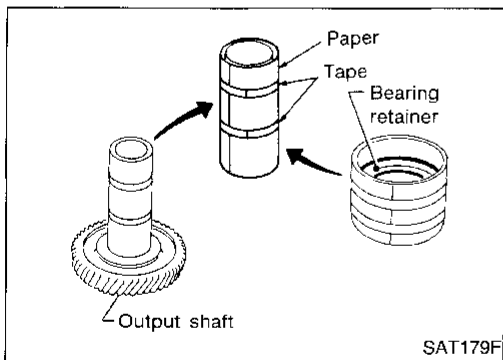

- Roll paper around seal rings to prevent seal rings from spreading.

Band Servo Piston Assembly

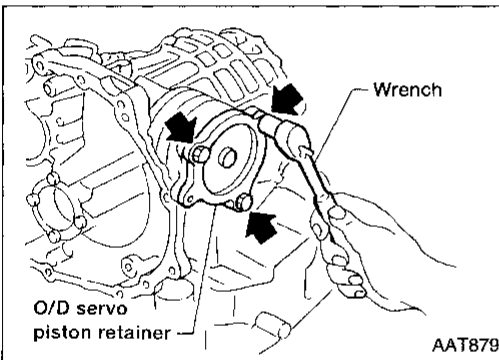
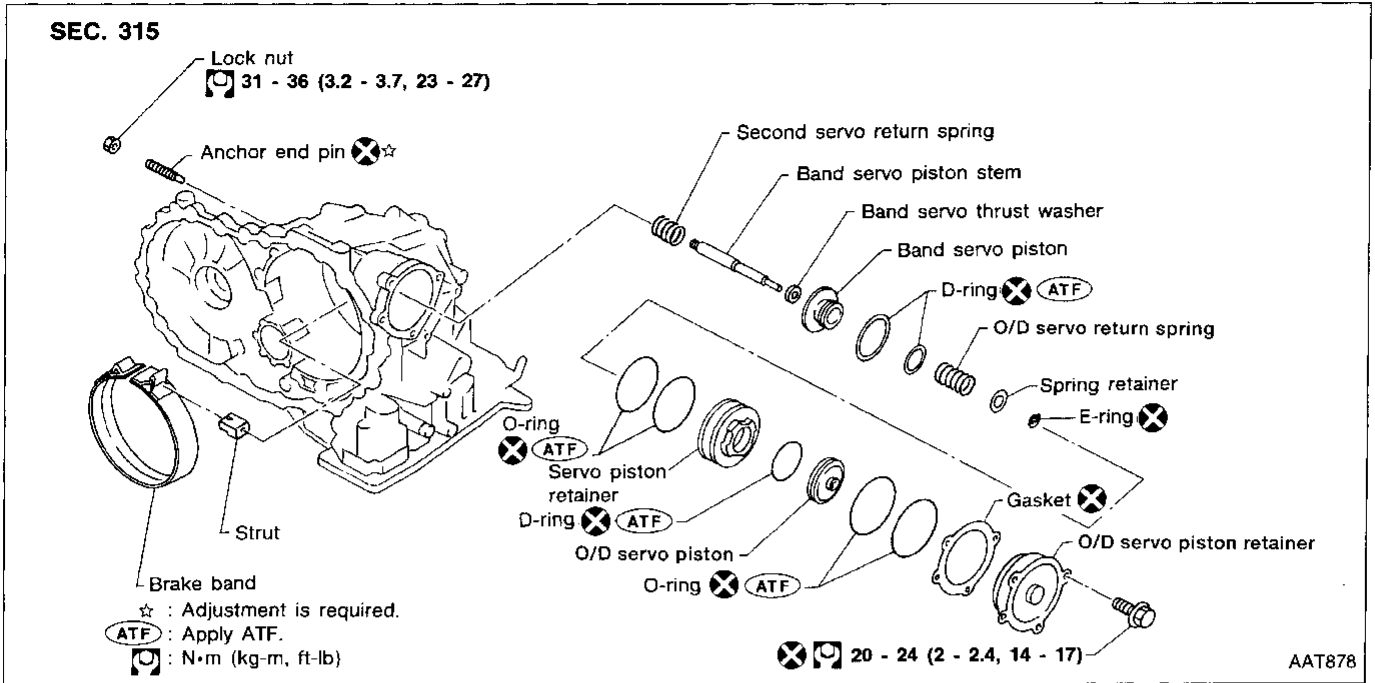

DISASSEMBLY

1. Remove band servo piston fixing bolts.

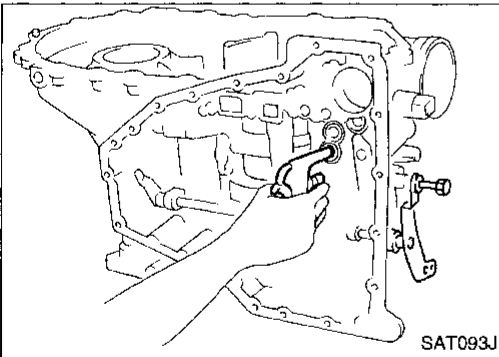

2. Apply compressed air to oil hole in transmission case to remove O/D servo piston retainer and band servo piston assembly.

- Hold band servo piston assembly with a rag or nylon waste.

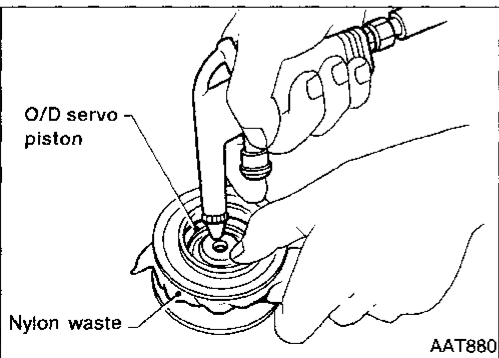

3. Apply compressed air to oil hole in O/D servo piston retainer to remove O/D servo piston from retainer.

- Hold O/D band servo piston while applying compressed air.

GI
 MA
 EM
 LG
 EC
 FE
 CL
 MT
 AT
 FA
 RA
 BR
 ST
 RS
 BT
 HA
 EL
 IDX

REPAIR FOR COMPONENT PARTS

Band Servo Piston Assembly (Cont'd)

4. Remove D-ring from O/D servo piston.

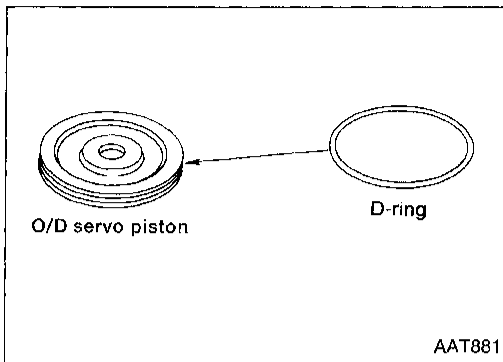

5. Remove O-rings from O/D servo piston retainer.

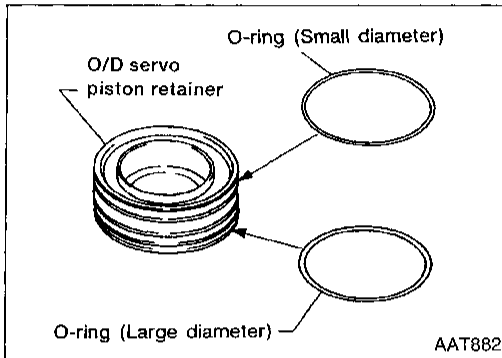

6. Remove band servo piston assembly from servo piston retainer by pushing it forward.

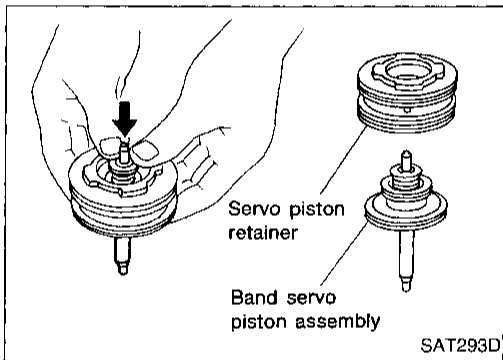

7. Place piston stem end on a wooden block. While pushing servo piston spring retainer down, remove E-ring.

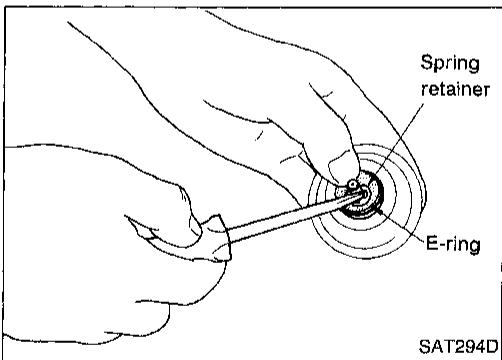

8. Remove O/D servo return spring, band servo thrust washer and band servo piston stem from band servo piston.

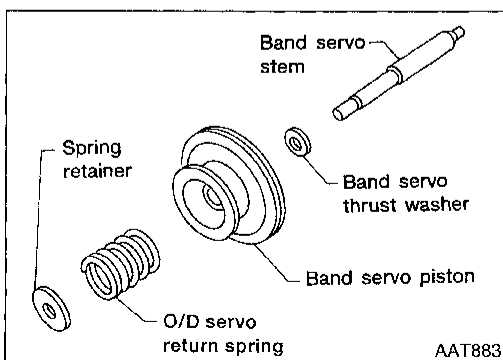

REPAIR FOR COMPONENT PARTS

Band Servo Piston Assembly (Cont'd)

9. Remove O-rings from servo piston retainer.

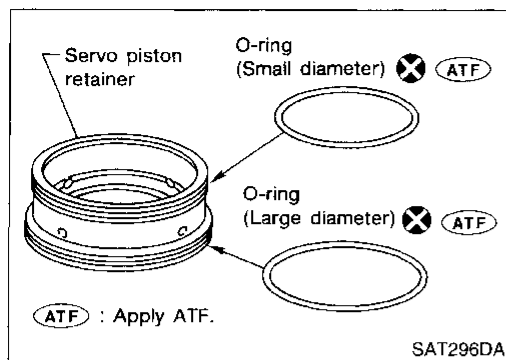

10. Remove D-rings from band servo piston.

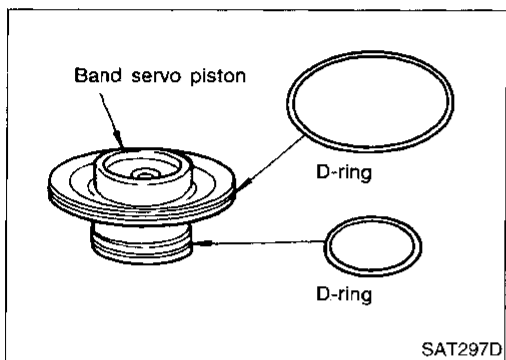

INSPECTION

Pistons, retainers and piston stem

- Check frictional surfaces for abnormal wear or damage.

GI

MA

EM

LC

EC

FE

CL

MT

AT

FA

RA

BR

ST

RS

BT

HA

EL

IDX

Return springs

- Check for deformation or damage.
- Measure free length and outer diameter.

Inspection standard:

Refer to SDS, AT-306.

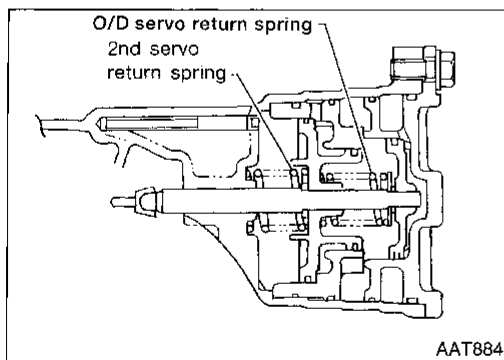

ASSEMBLY

1. Install D-rings to servo piston retainer.
- Apply ATF to D-rings.
 - Pay attention to position of each O-ring.

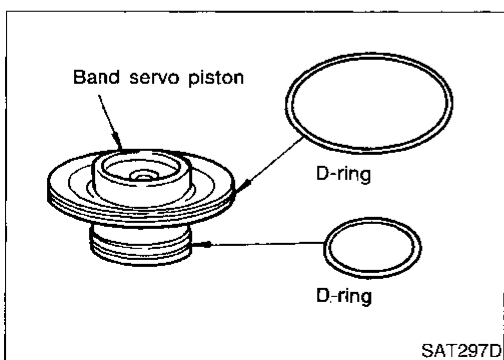

REPAIR FOR COMPONENT PARTS

Band Servo Piston Assembly (Cont'd)

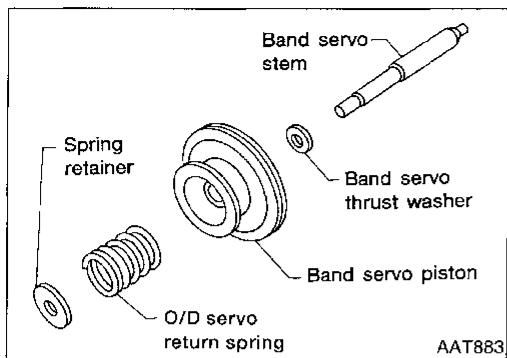

2. Install band servo piston stem, band servo thrust washer, O/D servo return spring and spring retainer to band servo piston.

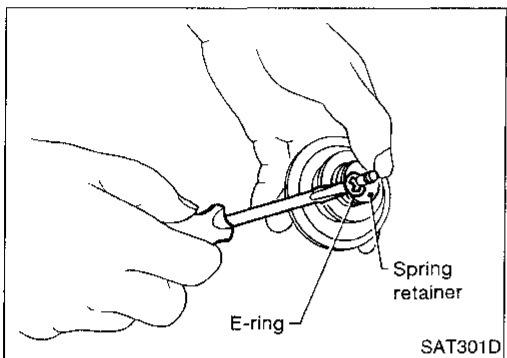

3. Place piston stem end on a wooden block. While pushing servo piston spring retainer down, install E-ring.

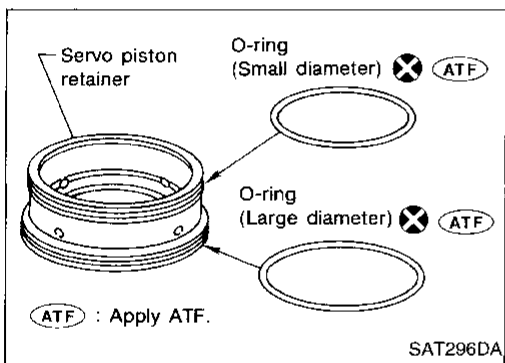

4. Install O-rings to servo piston retainer.
 - Apply ATF to O-rings.
 - Pay attention to position of each O-ring.

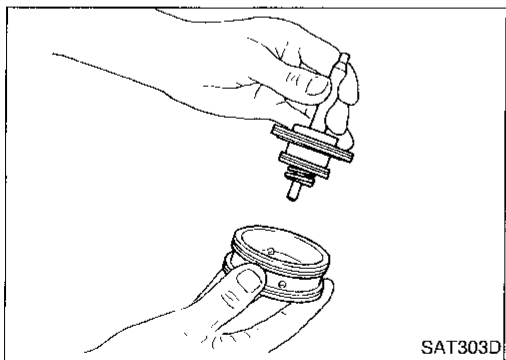

5. Install band servo piston assembly to servo piston retainer by pushing it inward.

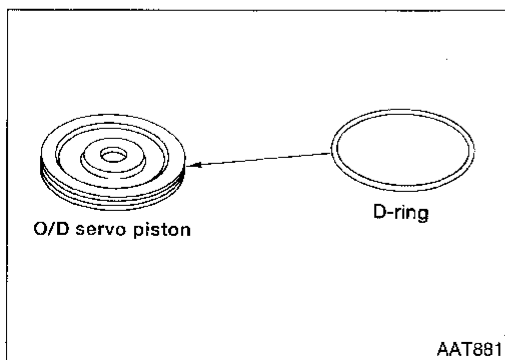

6. Install D-ring to O/D servo piston.
 - Apply ATF to D-ring.

REPAIR FOR COMPONENT PARTS

Band Servo Piston Assembly (Cont'd)

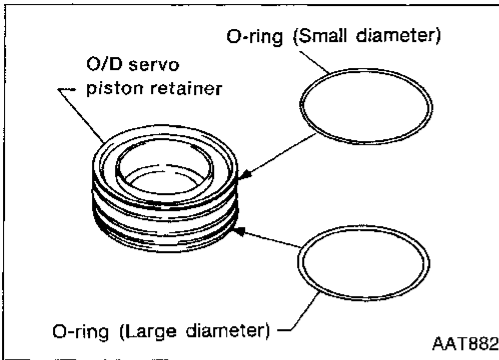

7. Install O-rings to O/D servo piston retainer.
 - Apply ATF to O-rings.
 - Pay attention to position of each O-ring.

GI

MA

EM

LC

EC

FE

CL

MT

AT

FA

RA

BR

ST

RS

BT

HA

EL

IDX

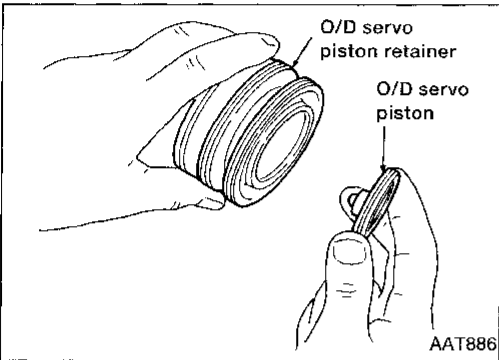

8. Install O/D servo piston to O/D servo piston retainer.

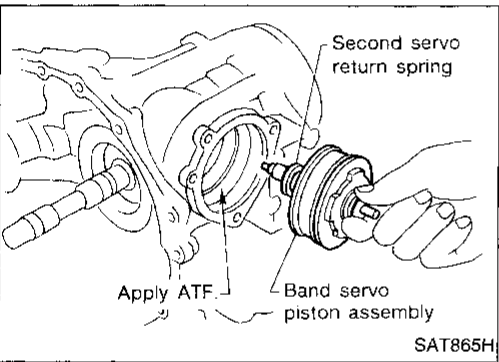

9. Install band servo piston assembly and 2nd servo return spring to transmission case.
 - Apply ATF to O-ring of band servo piston and transmission case.

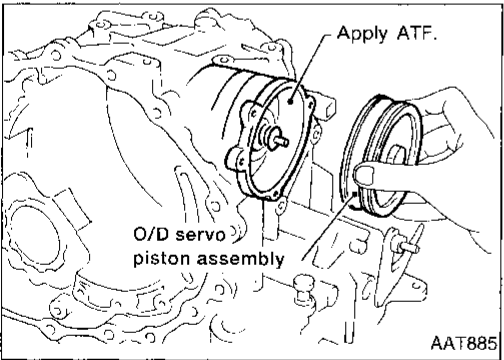

10. Install O/D servo piston assembly to transmission case.
 - Apply ATF to O-ring of band servo piston and transmission case.

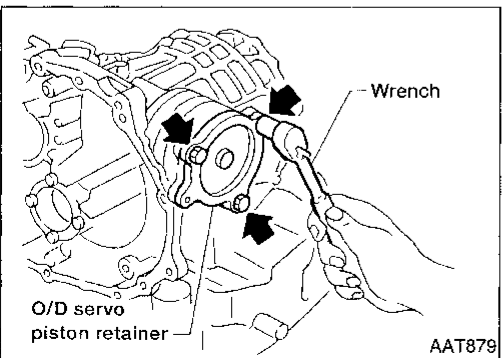

11. Install O/D servo piston retainer to transmission case.
⚙️: 20 - 24 N·m (2 - 2.4 kg·m, 14 - 17 ft·lb)

Final Drive

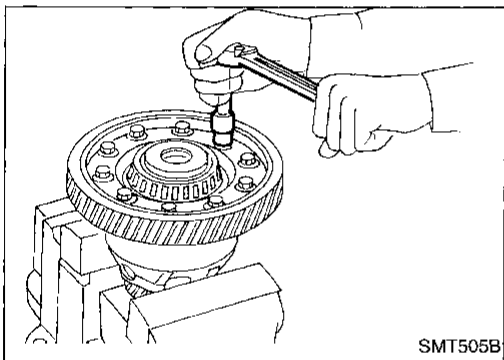
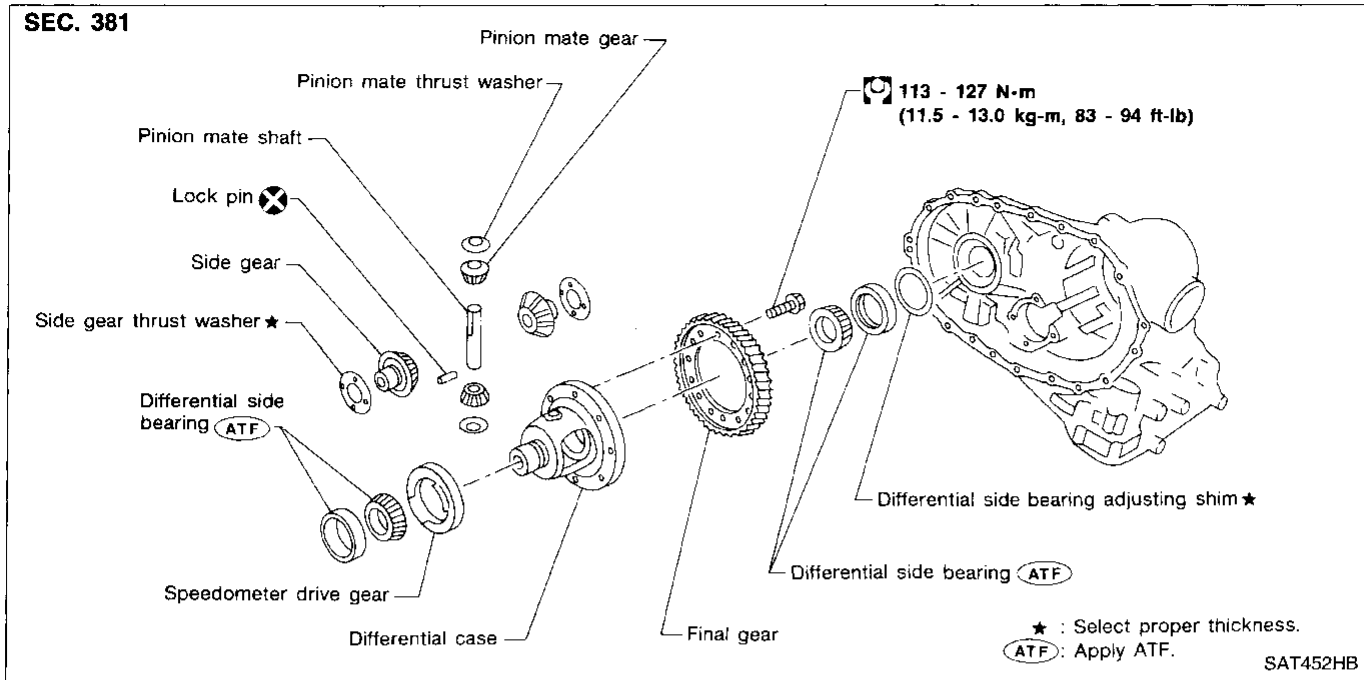

DISASSEMBLY

1. Remove final gear.

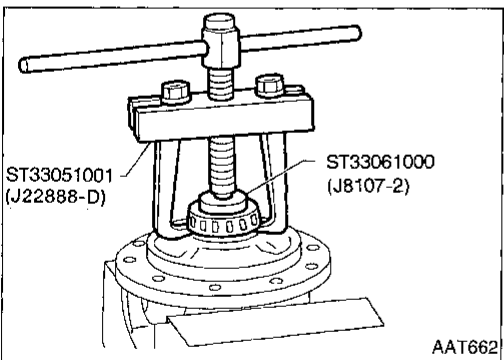

2. Press out differential side bearings.
 - Be careful not to mix up the right and left bearings.

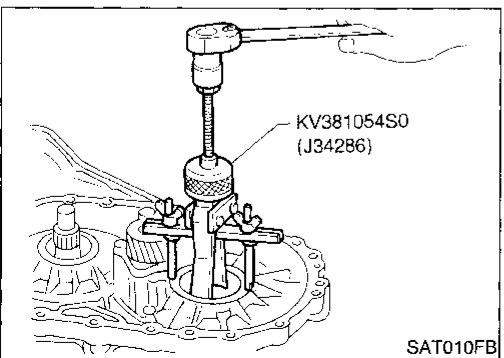

3. Remove differential side bearing outer race, and side bearing adjusting shim from transmission case.

REPAIR FOR COMPONENT PARTS

Final Drive (Cont'd)

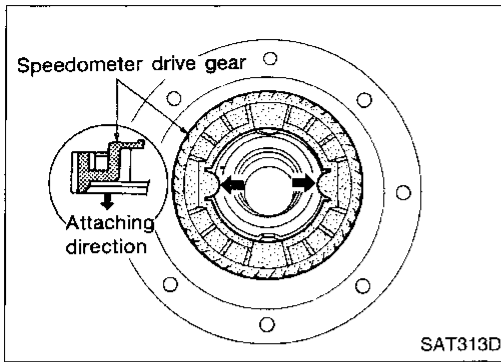

4. Remove speedometer drive gear.

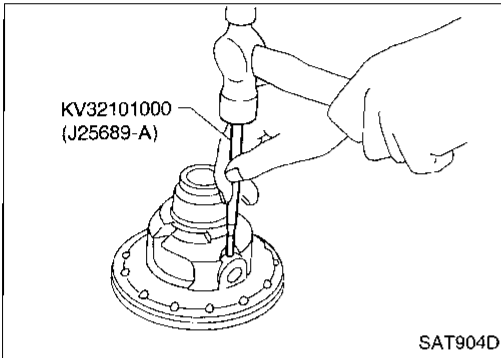

5. Drive out pinion mate shaft lock pin.

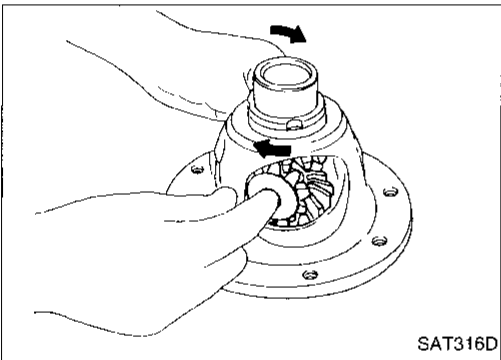

6. Draw out pinion mate shaft lock pin.

7. Remove pinion mate gears and side gears.

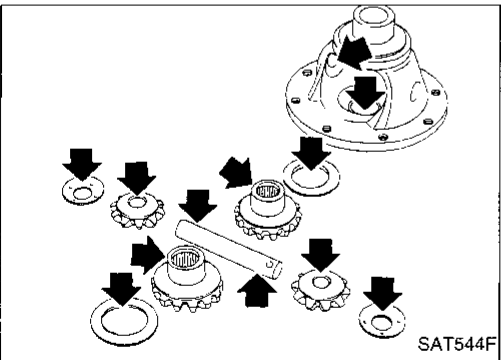

INSPECTION

Gear, washer, shaft and case

- Check mating surfaces of differential case, side gears and pinion mate gears.
- Check washers for wear.

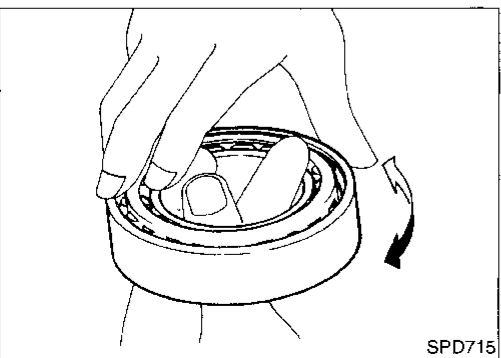

Bearings

- Make sure bearings roll freely and are free from noise, cracks, pitting or wear.
- **When replacing taper roller bearing, replace outer and inner race as a set.**

GI

MA

EM

LC

EC

FE

CL

MT

AT

FA

RA

BR

ST

RS

BT

HA

EL

IDX

REPAIR FOR COMPONENT PARTS

Final Drive (Cont'd)

ASSEMBLY

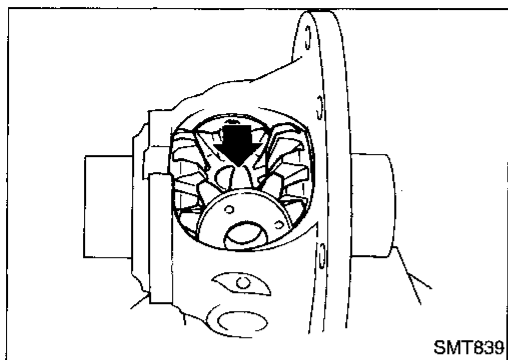

1. Attach side gear thrust washers to side gears, then install pinion mate thrust washers and pinion mate gears in place.

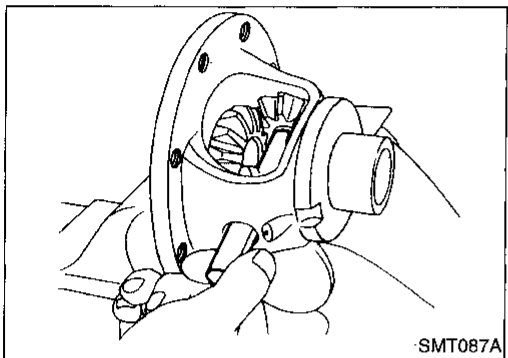

2. Insert pinion mate shaft.
 - When inserting, be careful not to damage pinion mate thrust washers.

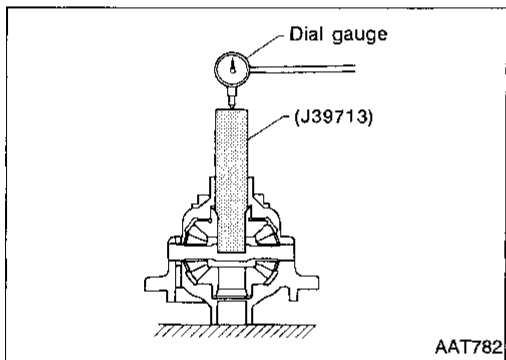

3. Measure clearance between side gear and differential case with washers following the procedure below:
 - a. Set Tool and dial indicator on side gear.

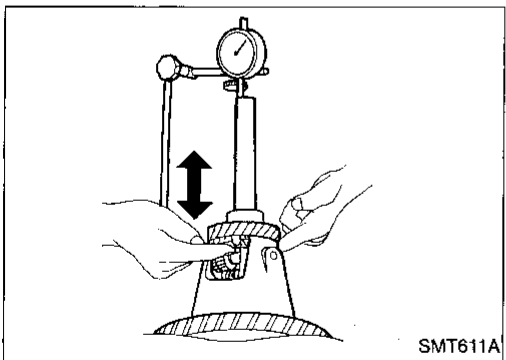

- b. Move side gear up and down to measure dial indicator deflection. Always measure indicator deflection on both side gears.

Clearance between side gear and differential case with washer:

0.1 - 0.2 mm (0.004 - 0.008 in)

- c. If not within specification, adjust clearance by changing thickness of differential side gear thrust washers.

Differential side gear thrust washers:

Refer to SDS, AT-304.

REPAIR FOR COMPONENT PARTS

Final Drive (Cont'd)

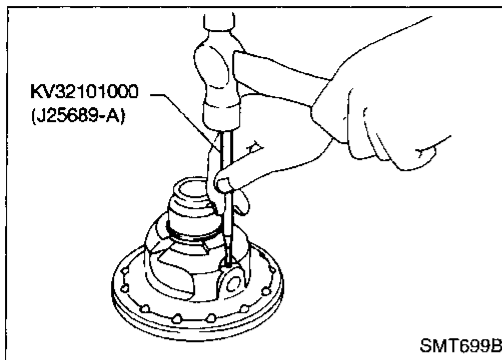

4. Install lock pin.
 - **Make sure that lock pin is flush with case.**

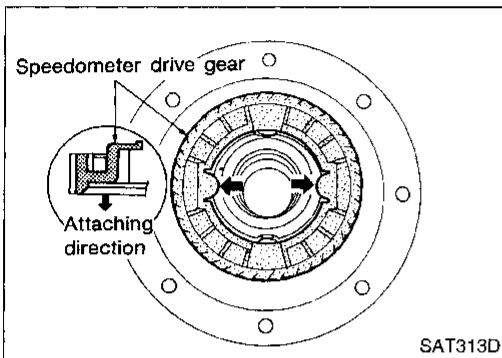

5. Install speedometer drive gear on differential case.
 - **Align the projection of speedometer drive gear with the groove of differential case.**

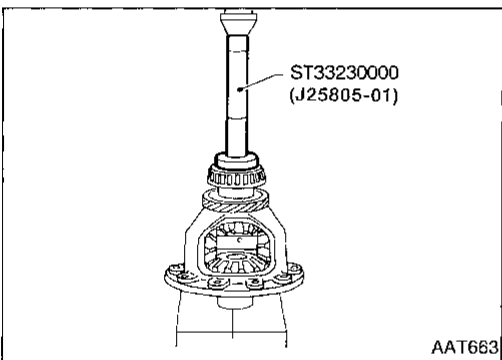

6. Press on differential side bearings.

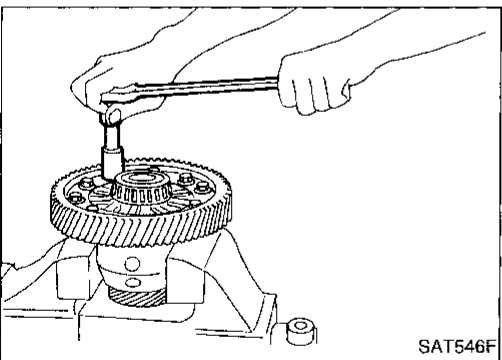

7. Install final gear and tighten fixing bolts in a crisscross pattern.
 - **Ⓜ: 113 - 127 N·m (11.5 - 13.0 kg·m, 83 - 94 ft·lb)**

GI

MA

EM

LC

EC

FE

CL

MT

AT

FA

RA

BR

ST

RS

BT

HA

EL

IDX

ASSEMBLY

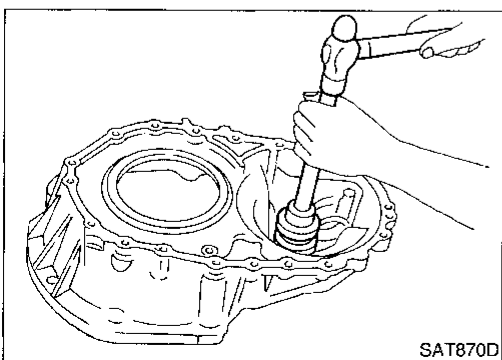
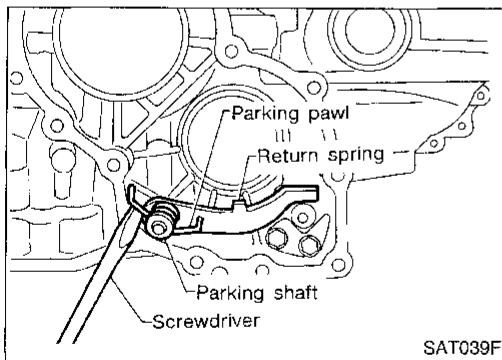
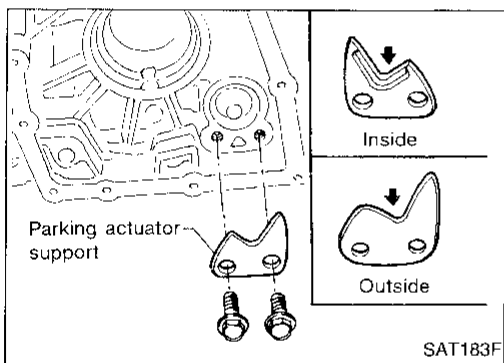
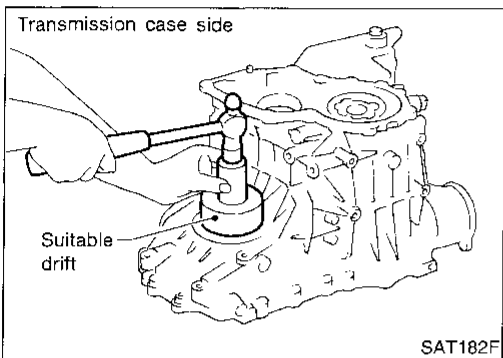
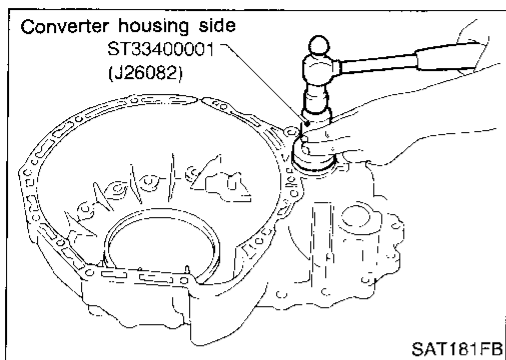

Assembly 1

1. Install differential side oil seals on transmission case and converter housing.

2. Install parking actuator support to transmission case.

- Pay attention to direction of parking actuator support.

3. Install parking pawl on transmission case and fix it with parking shaft.
4. Install return spring.

Adjustment 1

DIFFERENTIAL SIDE BEARING PRELOAD

1. Install differential side bearing outer race without adjusting shim on transmission case.
2. Install differential side bearing outer race on converter housing.

ASSEMBLY

Adjustment 1 (Cont'd)

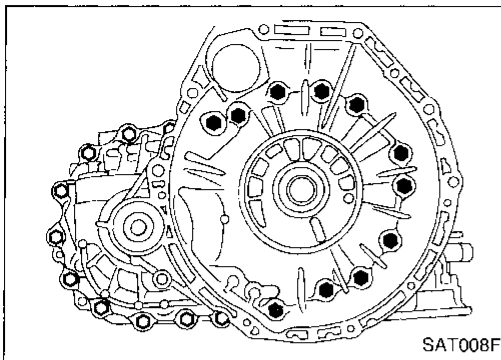

3. Place final drive assembly on transmission case.
4. Install transmission case on converter housing. Tighten transmission case fixing bolts to the specified torque. Refer to AT-210.

CI

MA

EM

LC

EC

FE

CL

MT

AT

FA

RA

BR

ST

RS

BT

HA

EL

IDX

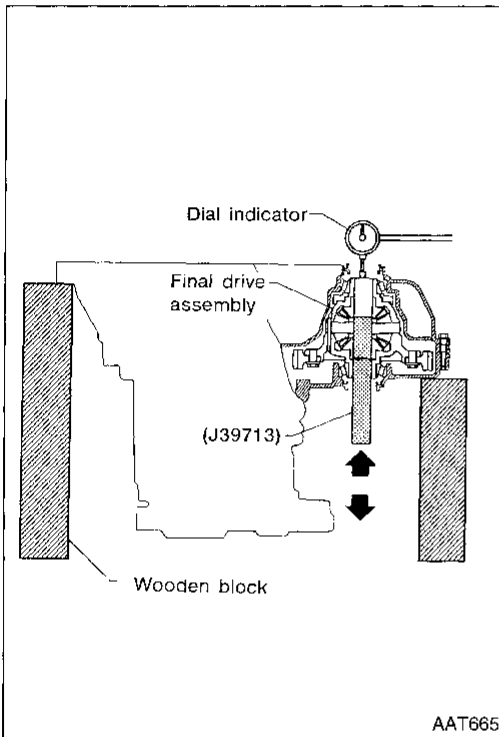

5. Attach dial indicator on differential case at converter housing side.
6. Insert Tool into differential side gear from transmission case side.
7. Move Tool up and down and measure dial indicator deflection.
8. Select proper thickness of differential side bearing adjusting shim(s).

**Suitable shim thickness = Dial indicator deflection
+ Specified bearing preload**
Differential side bearing preload adjusting shim:
Refer to SDS, AT-304.

Bearing preload:
0.05 - 0.09 mm (0.0020 - 0.0035 in)

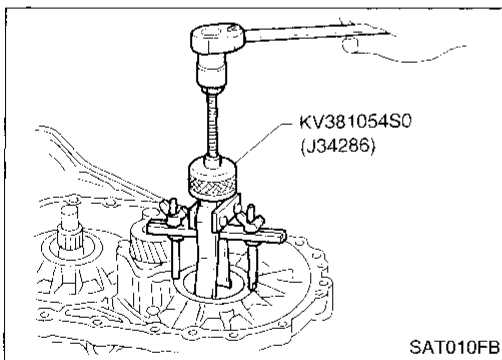

9. Remove converter housing from transmission case.
10. Remove final drive assembly from transmission case.
11. Remove differential side bearing outer race from transmission case.
12. Reinstall differential side bearing outer race and shim(s) selected from SDS table on transmission case.
13. Reinstall converter housing on transmission case and tighten transmission case fixing bolts to the specified torque. Refer to AT-210.

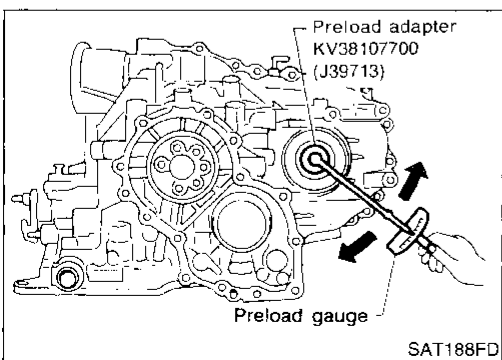

14. Insert Tool and measure turning torque of final drive assembly.

- Turn final drive assembly in both directions several times to seat bearing rollers correctly.

Turning torque of final drive assembly (New bearing):

0.78 - 1.37 N·m (8.0 - 14.0 kg·cm, 6.9 - 12.2 in·lb)

- When old bearing is used again, turning torque will be slightly less than the above.
- Make sure torque is close to the specified range.

ASSEMBLY

Adjustment 1 (Cont'd)

REDUCTION PINION GEAR BEARING PRELOAD

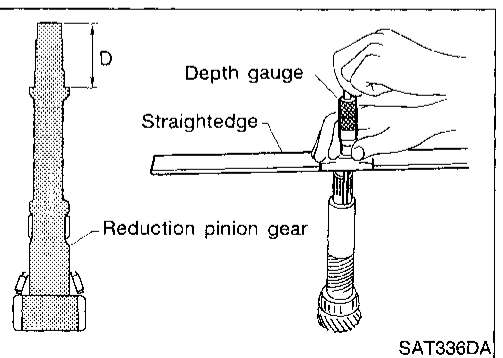
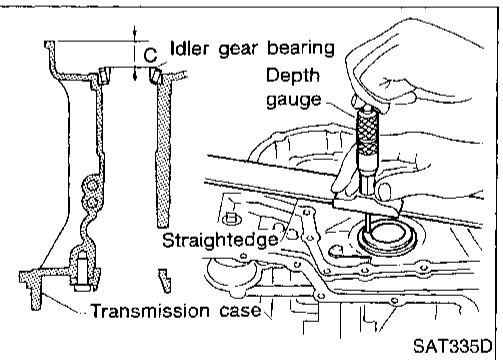
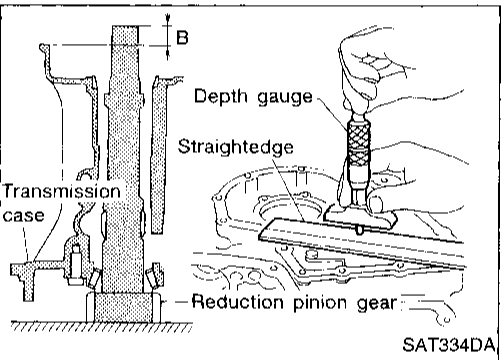
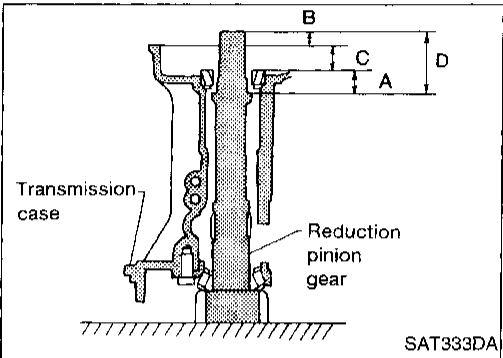
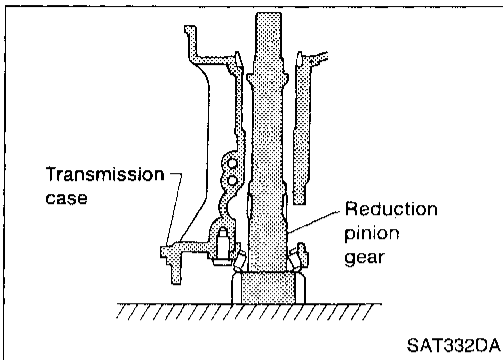

1. Remove transmission case and final drive assembly from converter housing.
2. Select proper thickness of reduction pinion gear bearing adjusting shim using the following procedures.
 - a. Place reduction pinion gear on transmission case as shown.

- b. Place idler gear bearing on transmission case.
- c. Measure dimensions "B" "C" and "D" and calculate dimension "A".

$$A = D - (B + C)$$

"A": Distance between the surface of idler gear bearing inner race and the adjusting shim mating surface of reduction pinion gear.

- Measure dimension "B" between the end of reduction pinion gear and the surface of transmission case.
- Measure dimension "B" in at least two places.

- Measure dimension "C" between the surface of idler gear bearing inner race and the surface of transmission case.
- Measure dimension "C" in at least two places.

- Measure dimension "D" between the end of reduction pinion gear and the adjusting shim mating surface of reduction pinion gear.
- Measure dimension "D" in at least two places.

- Calculate dimension "A".

$$A = D - (B + C)$$

ASSEMBLY

Adjustment 1 (Cont'd)

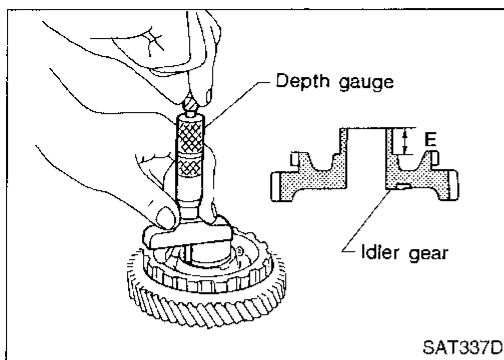

- d. Measure dimension "E" between the end of idler gear and the idler gear bearing inner race mating surface of idler gear.

- Measure dimension "E" in at least two places.

- e. Select proper thickness of reduction pinion gear bearing adjusting shim.

Proper shim thickness = A - E - 0.5 mm (0.020 in)*
 (* ... Bearing preload)

**Reduction pinion gear bearing adjusting shim:
 Refer to SDS, AT-305.**

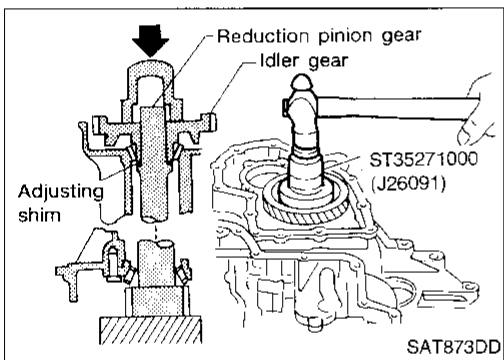

3. Install reduction gear and reduction gear bearing adjusting shim selected in step 2-e on transmission case.

4. Press idler gear bearing inner race on idler gear.

5. Press idler gear on reduction gear.

- Press idler gear until idler gear fully contacts adjusting shim.

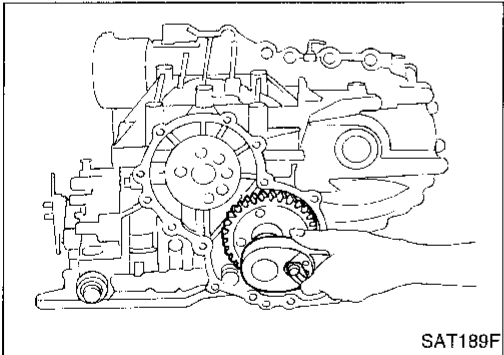

6. Tighten idler gear lock nut to the specified torque. Refer to AT-268.

- Lock idler gear with parking pawl when tightening lock nut.

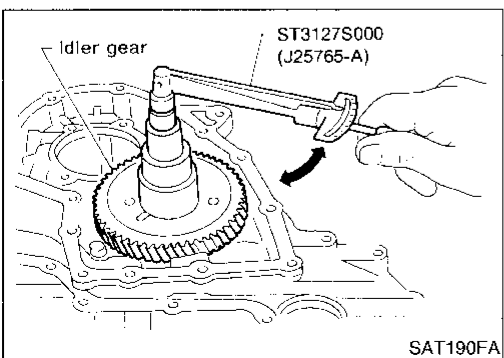

7. Measure turning torque of reduction pinion gear.

- When measuring turning torque, turn reduction pinion gear in both directions several times to seat bearing rollers correctly.

Turning torque of reduction pinion gear:

0.05 - 0.39 N·m (0.5 - 4.0 kg-cm, 0.43 - 3.47 in-lb)

- If turning torque is out of specification, decrease or increase thickness of reduction pinion gear bearing adjusting shim.

ASSEMBLY

Adjustment 1 (Cont'd)

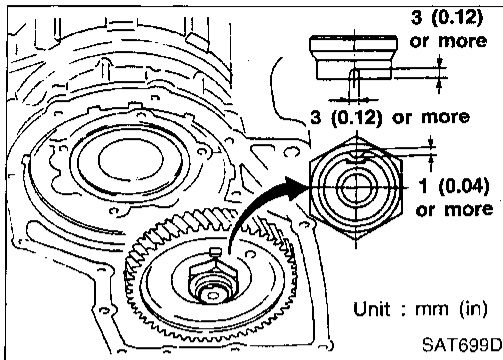

8. After properly adjusting turning torque, clinch idler gear lock nut as shown.

OUTPUT SHAFT END PLAY

- Measure clearance between side cover and the end of the output shaft bearing.
- Select proper thickness of adjusting shim so that clearance is within specifications.

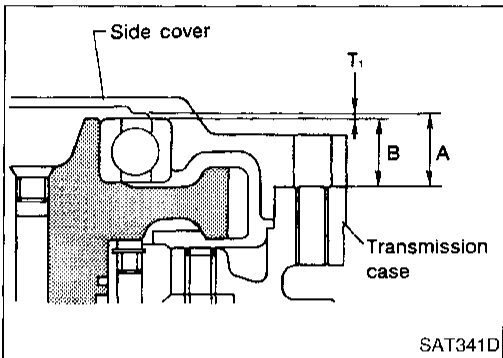

1. Install bearing retainer for output shaft.

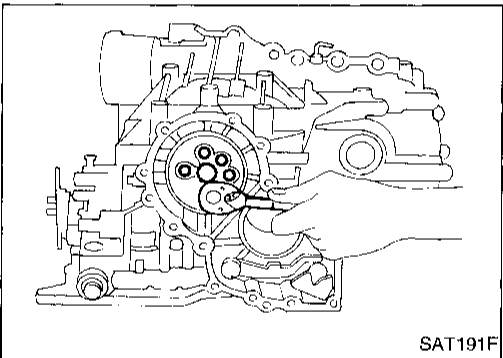

2. Install output shaft thrust needle bearing on bearing retainer.

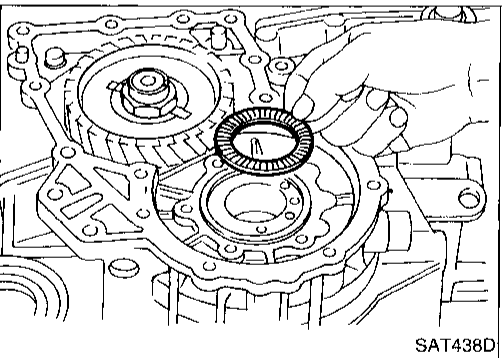

3. Install output shaft on transmission case.

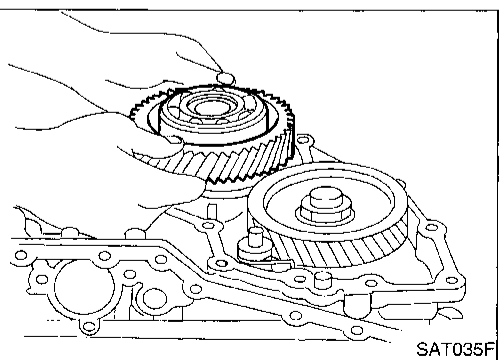

ASSEMBLY

Adjustment 1 (Cont'd)

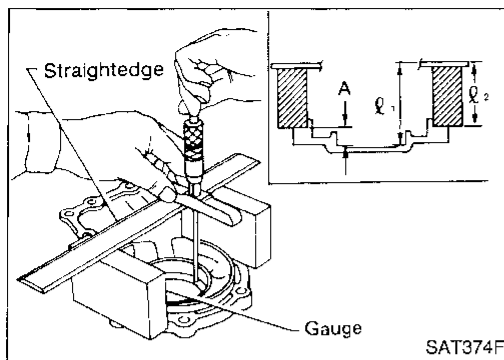

4. Measure dimensions " l_1 " and " l_2 " at side cover and then calculate dimension "A".

- Measure dimension " l_1 " and " l_2 " in at least two places.
- "A": Distance between transmission case fitting surface and adjusting shim mating surface.
- $A = l_1 - l_2$ l_2 : Height of gauge

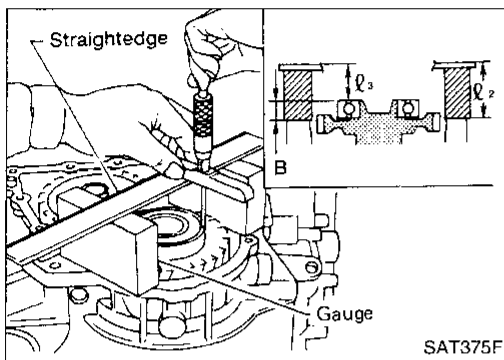

5. Measure dimensions " l_2 " and " l_3 " and then calculate dimension "B".

- Measure " l_2 " and " l_3 " in at least two places.
- "B": Distance between the end of output shaft bearing outer race and the side cover fitting surface of transmission case.
- $B = l_2 - l_3$ l_2 : Height of gauge

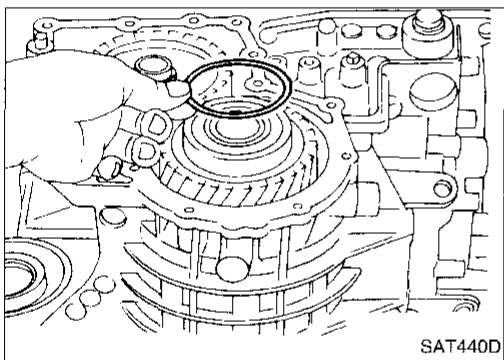

6. Select proper thickness of adjusting shim so that output shaft end play (clearance between side cover and output shaft bearing) is within specifications.

Output shaft end play (A - B):
0 - 0.15 mm (0 - 0.0059 in)

Output shaft end play adjusting shims:
Refer to SDS, AT-306.

7. Install adjusting shim on output shaft bearing.

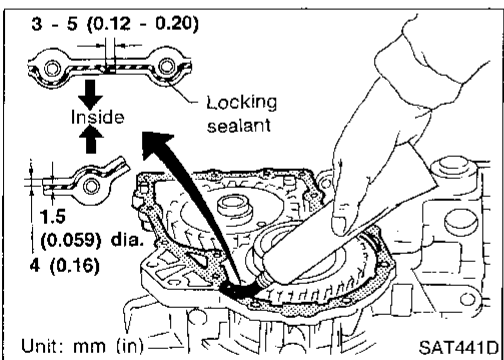

Assembly 2

1. Apply locking sealant (Loctite #518) to transmission case as shown in illustration.

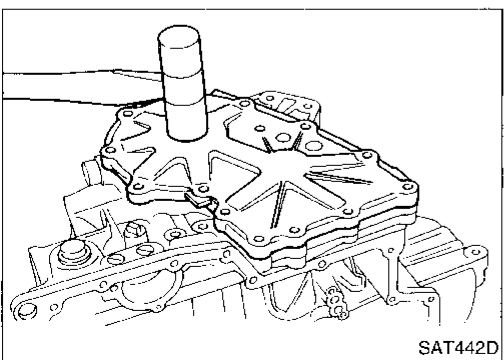

2. Set side cover on transmission case.

- Apply locking sealant to the mating surface of transmission case.

ASSEMBLY

Assembly 2 (Cont'd)

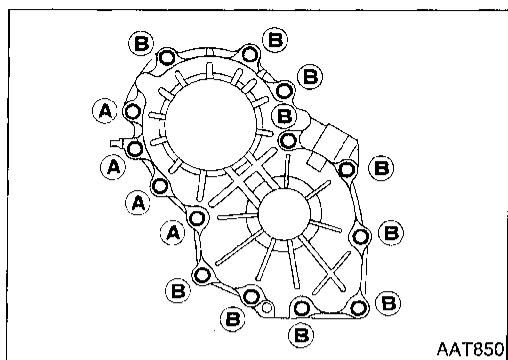

3. Tighten side cover fixing bolts to specified torque.
Ⓜ: 3.0 - 3.4 N·m (0.31 - 0.35 kg·m, 26.9 - 30.4 in·lb)

 - Do not mix bolts (A) and (B).
 - Always replace bolts (A) as they are self-sealing bolts.

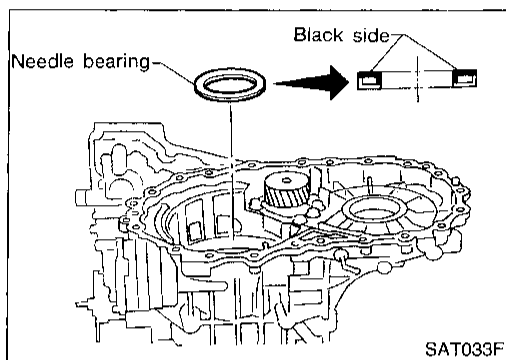

4. Remove paper rolled around bearing retainer.
5. Install thrust washer on bearing retainer.

 - Apply petroleum jelly to thrust washer.

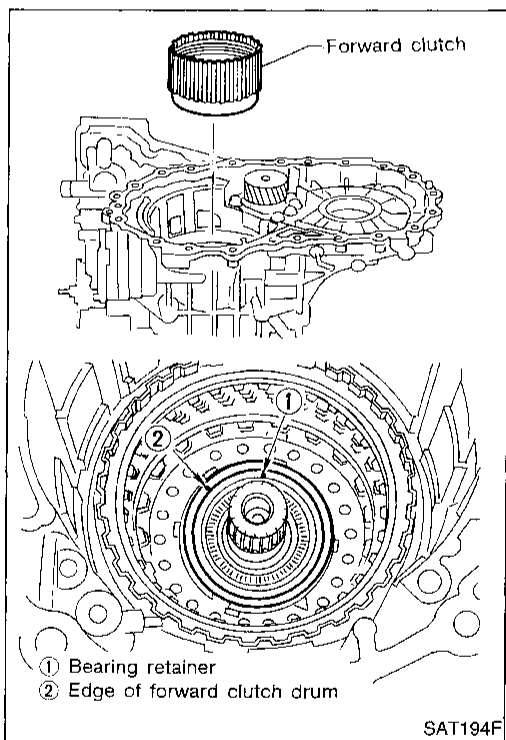

6. Install forward clutch assembly.

 - Align teeth of low & reverse brake drive plates before installing.
 - Make sure that bearing retainer seal rings are not spread.
 - If forward clutch assembly is correctly seated, points ① and ② are at almost same level.

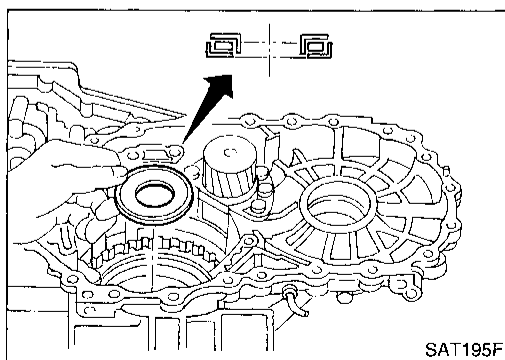

7. Install thrust needle bearing on bearing retainer.

 - Apply petroleum jelly to thrust needle bearing.
 - Pay attention to direction of thrust needle bearing.

ASSEMBLY

Assembly 2 (Cont'd)

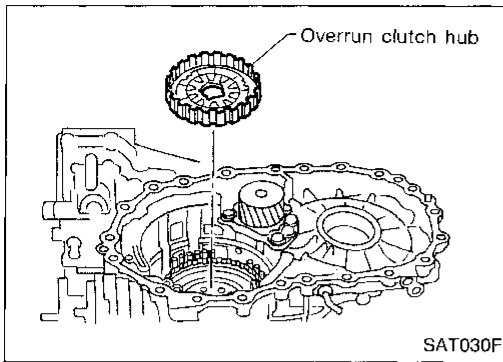

8. Install overrun clutch hub.
 - Apply petroleum jelly to thrust washers.
 - Align teeth of overrun clutch drive plates before installing.

GI

MA

EM

LC

EC

FE

CL

MT

AT

FA

RA

BR

ST

RS

ET

HA

EL

IDX

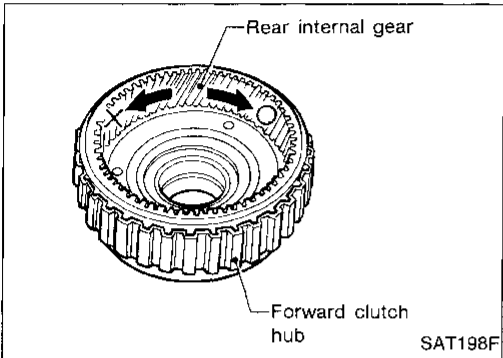

9. Hold forward clutch hub and turn rear internal gear. Check overrun clutch hub for correct directions of lock and unlock.
 - If not shown as illustrated, check installed direction of forward one-way clutch.

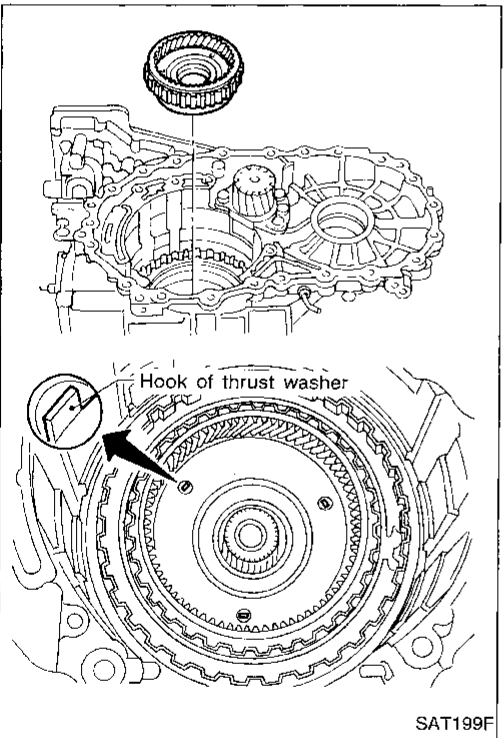

10. Install forward clutch hub and rear internal gear assembly.
 - Align teeth of forward clutch drive plates before installing.
 - Check that three hooks of thrust washer are correctly aligned after installing.

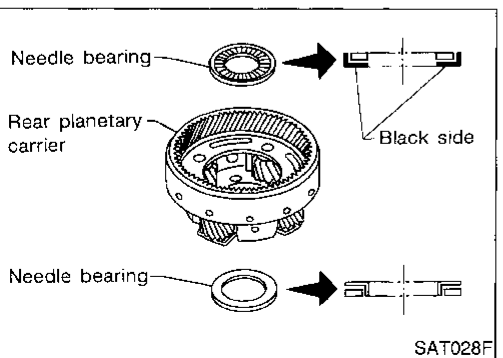

11. Install rear planetary carrier assembly and rear sun gear according to the following procedures.
 - a. Install needle bearings on rear planetary carrier.
 - Apply petroleum jelly to needle bearings.
 - Pay attention to direction of needle bearings.

ASSEMBLY

Assembly 2 (Cont'd)

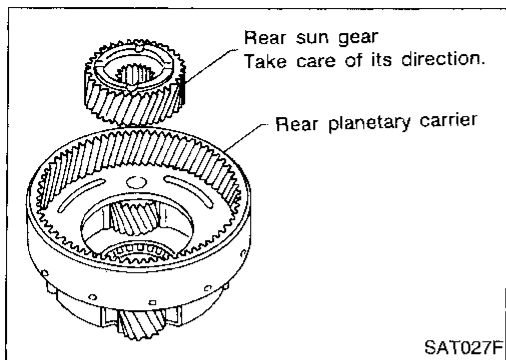

- b. Install rear sun gear on rear planetary carrier.
- **Pay attention to direction of rear sun gear.**

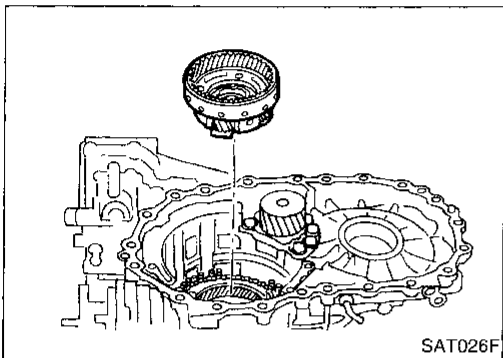

- c. Install rear planetary carrier on transmission case.

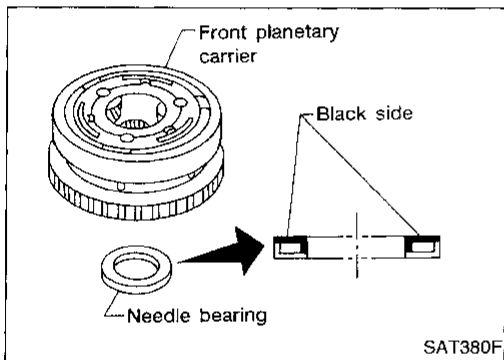

12. Install thrust needle bearing on front planetary carrier, then install them together on transmission case.
- **Apply petroleum jelly to thrust needle bearing.**
- **Pay attention to direction of thrust needle bearing.**

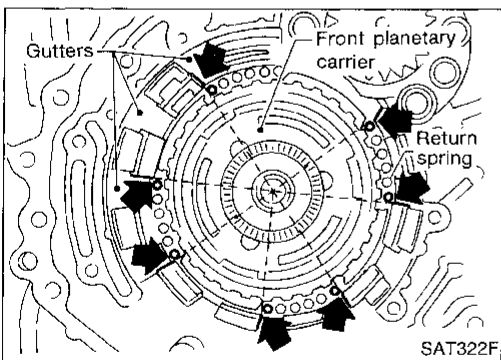

13. Install low and reverse brake piston according to the following procedures.
- a. Set and align return springs to transmission case gutters as shown in illustration.

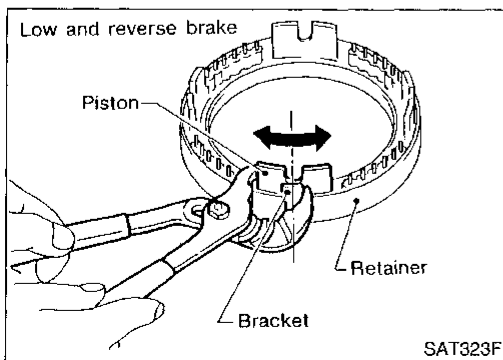

- b. Set and align piston with retainer.

ASSEMBLY

Assembly 2 (Cont'd)

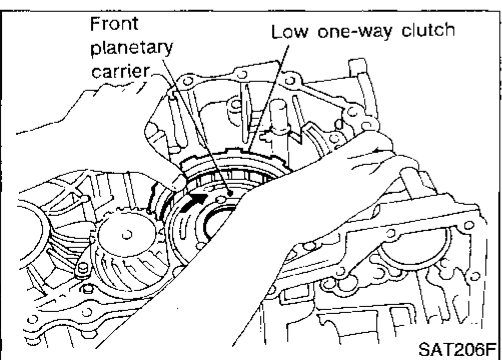
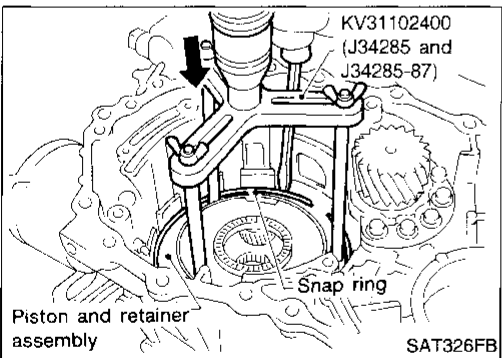
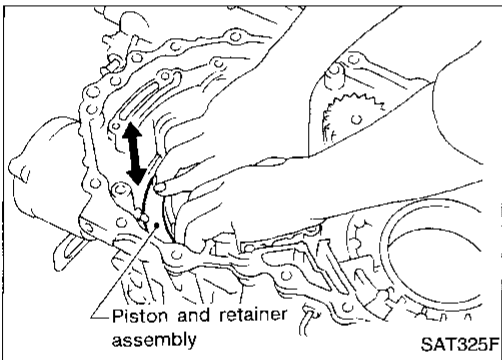
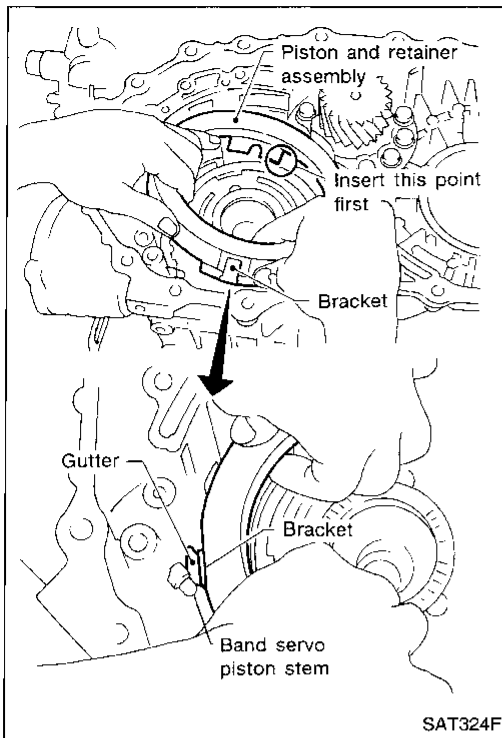

c. Install piston and retainer assembly on the transmission case.

- **Align bracket to specified gutter as indicated in illustration.**

GI

MA

EM

LC

EC

FE

CL

MT

AT

FA

RA

BR

ST

RS

BT

HA

EL

IDX

d. Check that each protrusion of piston is correctly set to corresponding return spring as follows.

- **Push piston and retainer assembly evenly and confirm they move smoothly.**
- **If they can not move smoothly, remove piston and retainer assembly and align return spring correctly as instructed in step "a".**

e. Push down piston and retainer assembly and install snap ring.

14. Install low one-way clutch to front planetary carrier by turning carrier in the direction of the arrow shown.

ASSEMBLY

Assembly 2 (Cont'd)

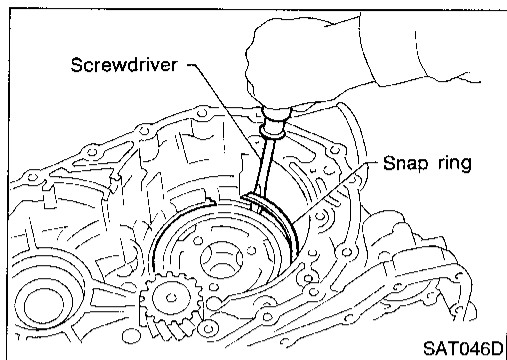

15. Install snap ring with screwdriver.

- **Forward clutch and bearing must be correctly installed for snap ring to fit into groove of transmission case.**

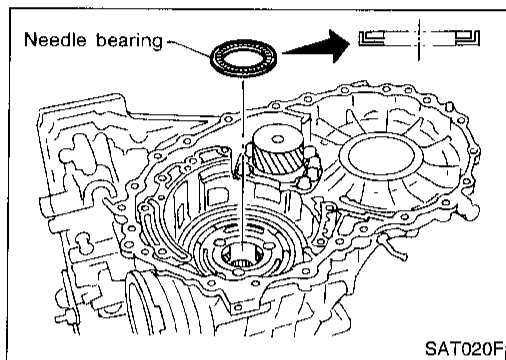

16. Install needle bearing on transmission case.

- **Apply petroleum jelly to needle bearing.**
- **Pay attention to direction of needle bearing.**

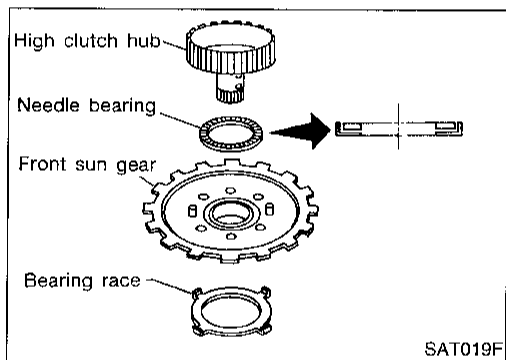

17. Install bearing race, needle bearing and high clutch hub on front sun gear.

- **Apply petroleum jelly to needle bearing.**
- **Pay attention to direction of needle bearing.**

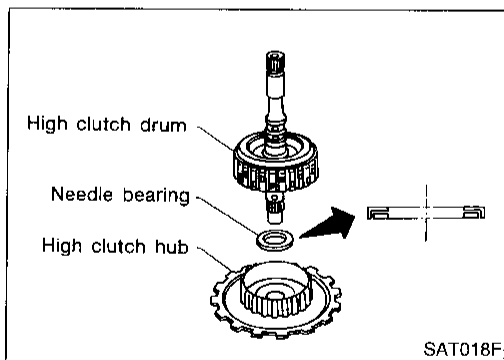

18. Install needle bearing and high clutch drum on high clutch hub.

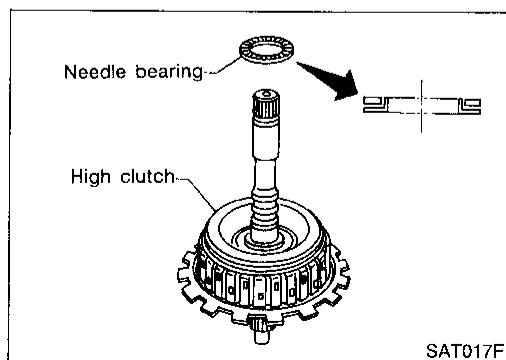

19. Install needle bearing on high clutch drum.

- **Apply petroleum jelly to needle bearing.**
- **Pay attention to direction of needle bearing.**

ASSEMBLY

Assembly 2 (Cont'd)

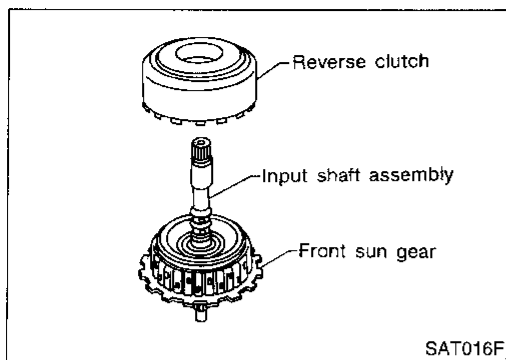

20. Remove paper rolled around input shaft.
21. Install input shaft assembly in reverse clutch.

- **Align teeth of reverse clutch drive plates before installing.**

GI

MA

EM

LC

EC

FE

CL

MT

AT

FA

RA

BR

ST

RS

BT

HA

EL

IDX

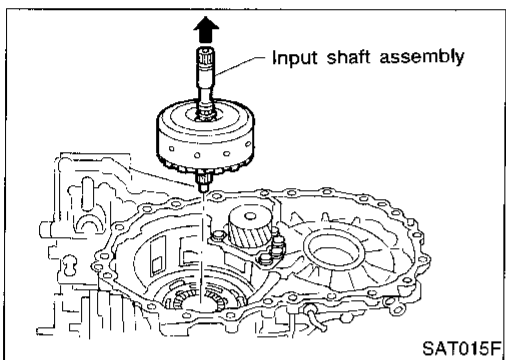

22. Install reverse clutch assembly on transmission case.

- **Align teeth of high clutch drive plates before installing.**

Adjustment 2

When any parts listed below are replaced, adjust total end play and reverse clutch end play.

Part name	Total end play	Reverse clutch end play
Transmission case	●	●
Overrun clutch hub	●	●
Rear internal gear	●	●
Rear planetary carrier	●	●
Rear sun gear	●	●
Front planetary carrier	●	●
Front sun gear	●	●
High clutch hub	●	●
High clutch drum	●	●
Oil pump cover	●	●
Reverse clutch drum	—	●

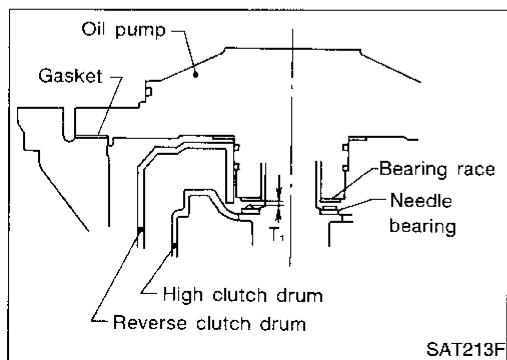

TOTAL END PLAY

1. Adjust total end play "T₁".

ASSEMBLY

Adjustment 2 (Cont'd)

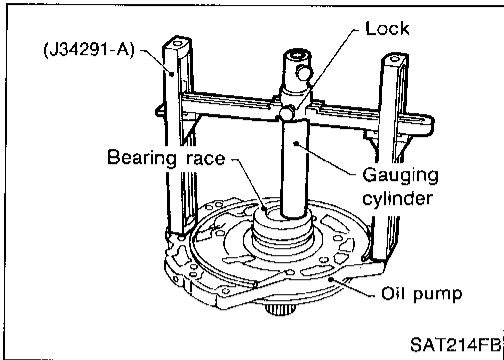

- a. With original bearing race installed, place Tool onto oil pump. The long ends of legs should be placed firmly on machined surface of oil pump assembly. The gauging cylinder should rest on top of bearing race. Lock gauging cylinder in place with set screw.

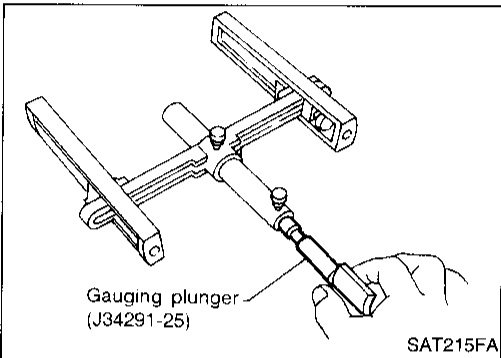

- b. Install gauging plunger into cylinder.

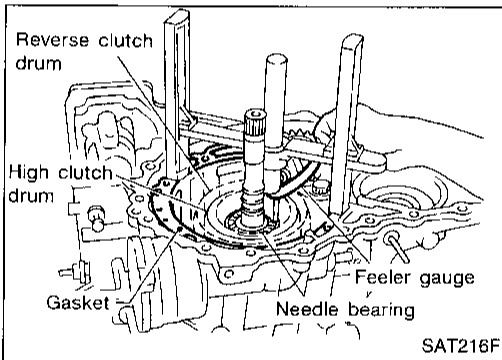

- c. With needle bearing installed on high clutch drum, place Tool legs on machined surface of transmission case (with gasket). Then allow plunger to rest on needle bearing.
 d. Measure gap between cylinder and plunger. This measurement should give exact total end play.

Total end play "T₁":

0.25 - 0.55 mm (0.0098 - 0.0217 in)

- If end play is out of specification, decrease or increase thickness of bearing race as necessary.

Available bearing race:

Refer to SDS, AT-307.

2. Adjust reverse clutch drum end play "T₂".

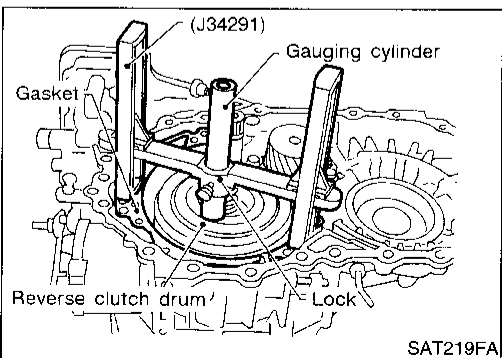
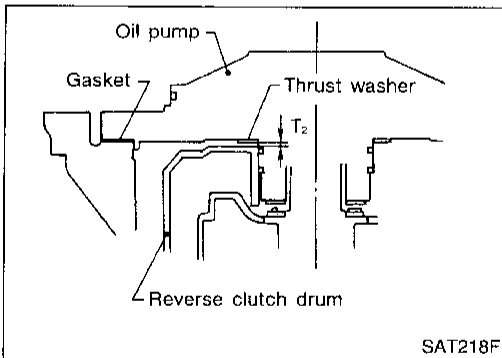

- a. Place Tool on machined surface of transmission case (with gasket). Then allow gauging cylinder to rest on reverse clutch drum. Lock cylinder in place with set screw.

ASSEMBLY

Adjustment 2 (Cont'd)

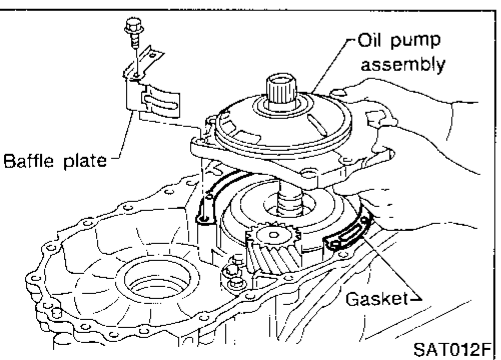
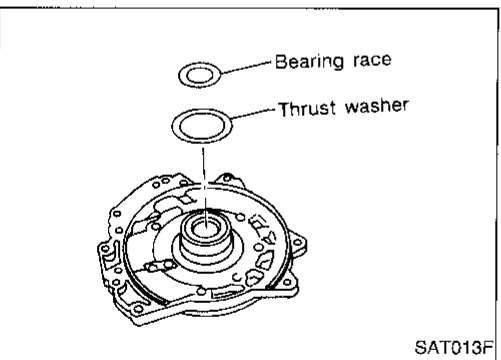
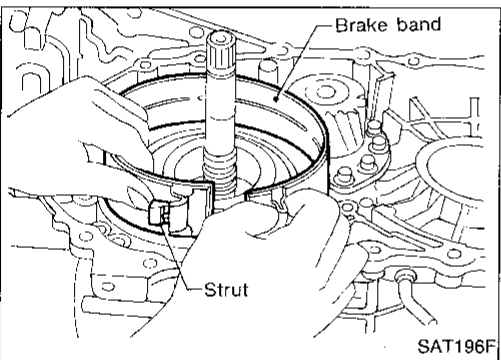
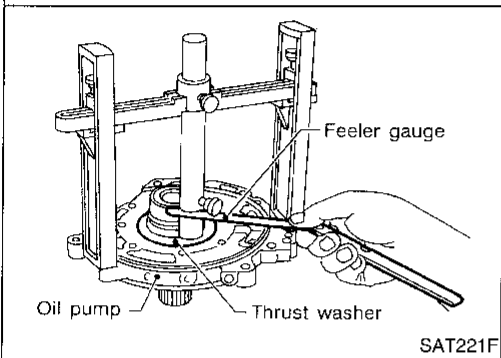
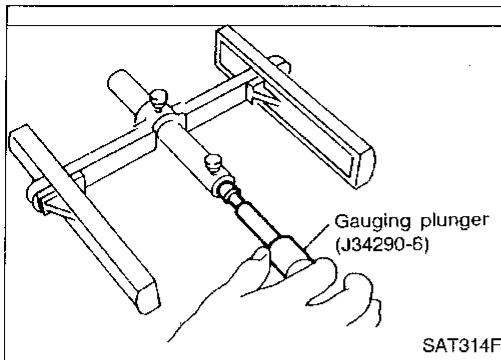

- b. Install gauging plunger into cylinder.
- c. With original thrust washer installed on oil pump, place Tool legs onto machined surface of oil pump assembly. Then allow plunger to rest on thrust washer.
- d. Measure gap between cylinder and plunger with feeler gauge. This measurement should give exact reverse clutch drum end play.

Reverse clutch drum end play "T₂":
0.55 - 0.90 mm (0.0217 - 0.0354 in)

- If end play is out of specification, decrease or increase thickness of thrust washer as necessary.

Available thrust washer:
Refer to SDS, AT-306.

Assembly 3

1. Install anchor end pin and lock nut on transmission case.
2. Place brake band on outside of reverse clutch drum. Tighten anchor end pin just enough so that brake band is evenly fitted on reverse clutch drum.

3. Place bearing race selected in total end play adjustment step on oil pump cover.

- **Apply petroleum jelly to bearing race.**

4. Place thrust washer selected in reverse clutch end play step on reverse clutch drum.

- **Apply petroleum jelly to thrust washer.**

5. Install oil pump assembly, baffle plate and gasket on transmission case.

6. Tighten oil pump fixing bolts to the specified torque.

ASSEMBLY

Assembly 3 (Cont'd)

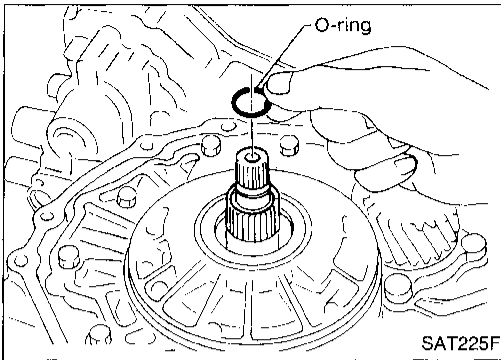

7. Install O-ring to input shaft.
 - Apply ATF to O-ring.

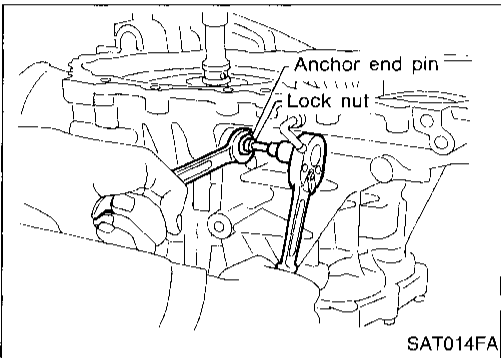

8. Adjust brake band.
 - a. Tighten anchor end pin to the specified torque.

Anchor end pin:
☛ : 3.9 - 5.9 N·m (0.4 - 0.6 kg-m, 35 - 52 in-lb)
 - b. Back off anchor end pin two and a half turns.
 - c. While holding anchor end pin, tighten lock nut.

Lock nut:
☛ : 31 - 36 N·m (3.2 - 3.7 kg-m, 23 - 27 ft-lb)

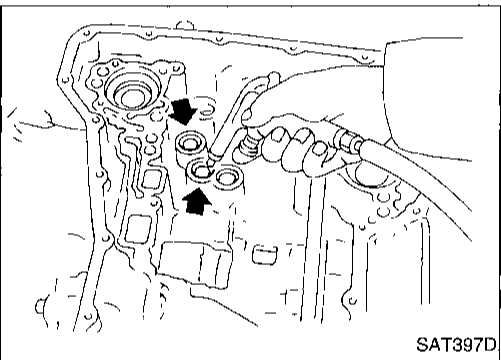

9. Apply compressed air to oil holes of transmission case and check operation of brake band.

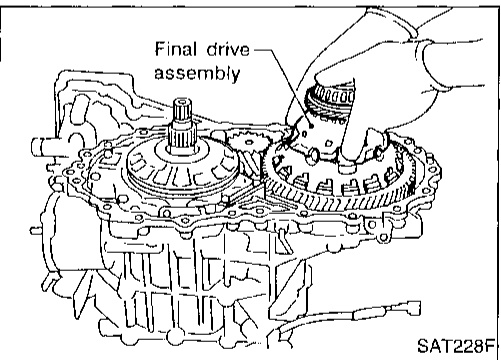

10. Install final drive assembly on transmission case.

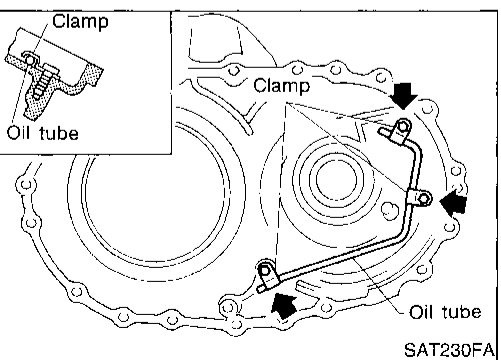

11. Install oil tube on converter housing.

ASSEMBLY

Assembly 3 (Cont'd)

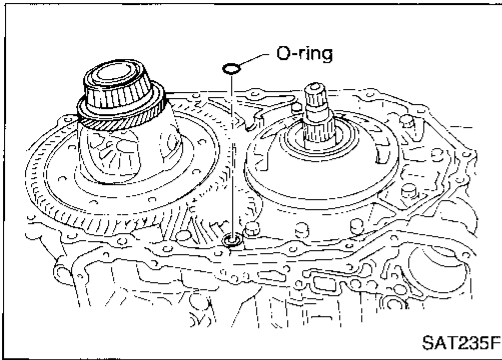

12. Install O-ring on differential oil port of transmission case.

GI

MA

EM

LC

EC

FE

CL

MT

AT

FA

RA

BR

ST

RS

BT

HA

EL

IDX

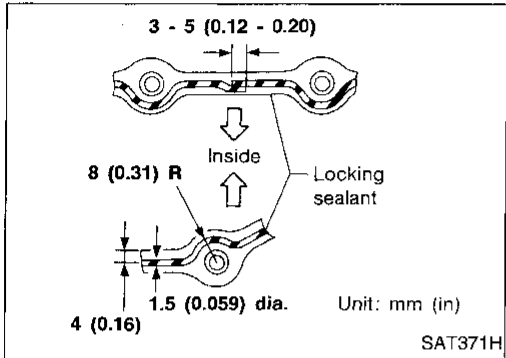

13. Install converter housing on transmission case.

- Apply locking sealant (Loctite #518) to mating surface of converter housing.

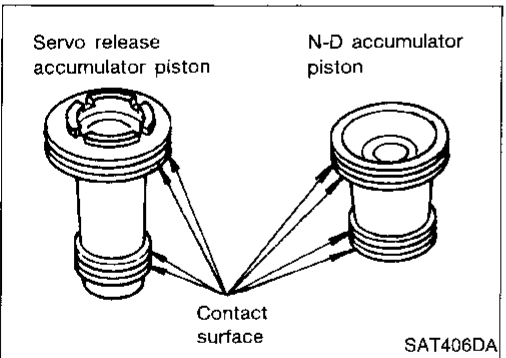
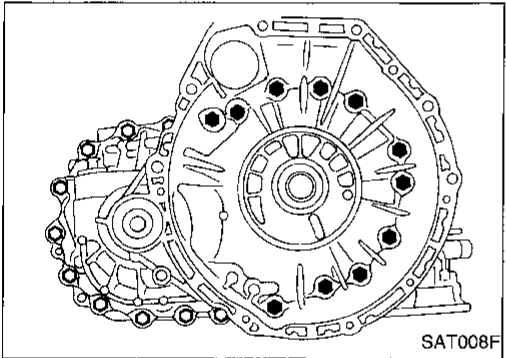

14. Install accumulator piston.

- a. Check contact surface of accumulator piston for damage.

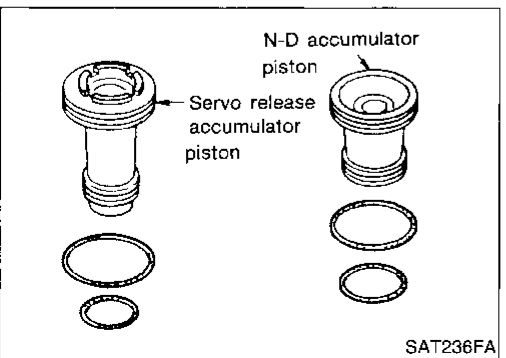

b. Install O-rings on accumulator piston.

- Apply ATF to O-rings.
Accumulator piston O-rings:
Refer to SDS, AT-306.

ASSEMBLY

Assembly 3 (Cont'd)

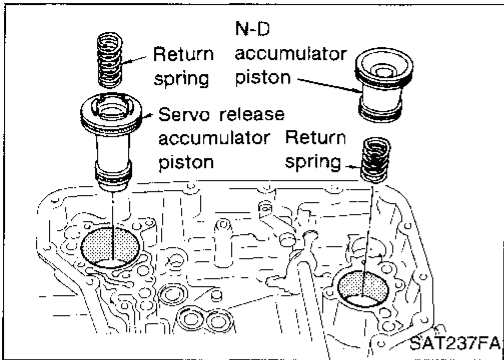

c. Install accumulator pistons and return springs on transmission case.

- **Apply ATF to inner surface of transmission case.**
Return springs:
Refer to SDS, AT-306.

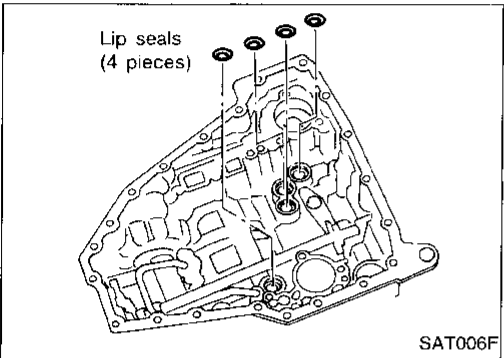

15. Install lip seals for band servo oil holes on transmission case.

- **Apply petroleum jelly to lip seals.**

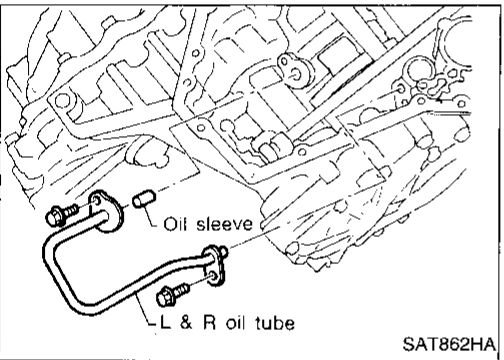

16. Install L & R oil tube and oil sleeve.

 : 5 - 7 N·m (0.5 - 0.7 kg-m, 43 - 61 in-lb)

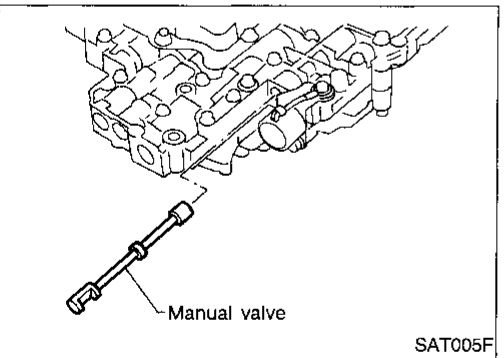

17. Install control valve assembly.

a. Insert manual valve into control valve assembly.

- **Apply ATF to manual valve.**

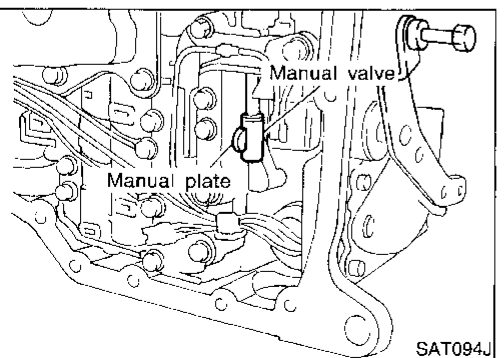

b. Set manual shaft in Neutral position.

c. Install control valve assembly on transmission case while aligning manual valve with manual plate.

ASSEMBLY

Assembly 3 (Cont'd)

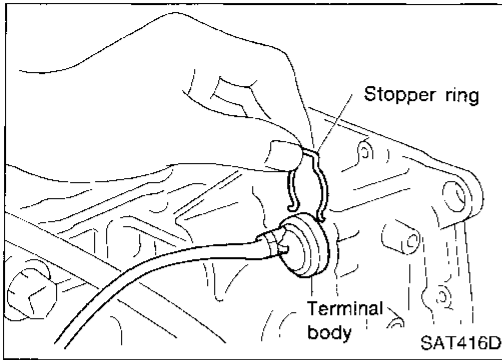

- d. Pass solenoid harness through transmission case and install terminal body on transmission case by pushing it.
- e. Install stopper ring to terminal body.

GI

MA

EM

LG

EC

FE

CL

MT

AT

FA

RA

BR

ST

RS

BT

HA

EL

IDX

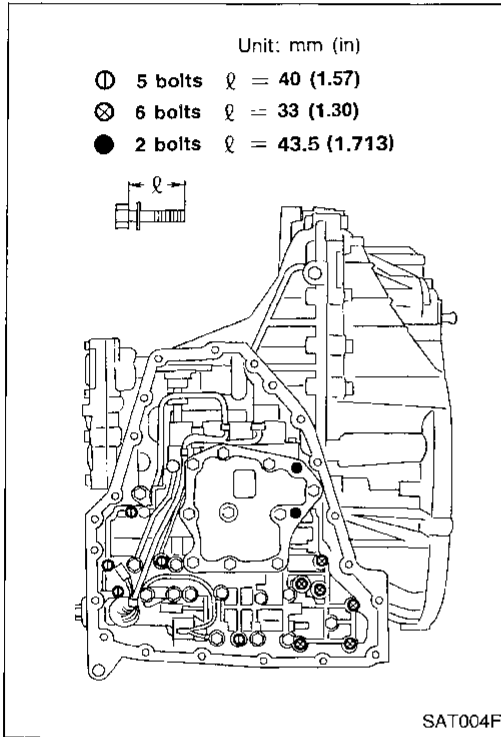

- f. Tighten bolts ①, ⊗ and ●.

Bolt length, number and location:

Bolt	①	⊗	●
Bolt length "ℓ" mm (in)	40.0 (1.575)	33.0 (1.299)	43.5 (1.713)
Number of bolts	5	6	2

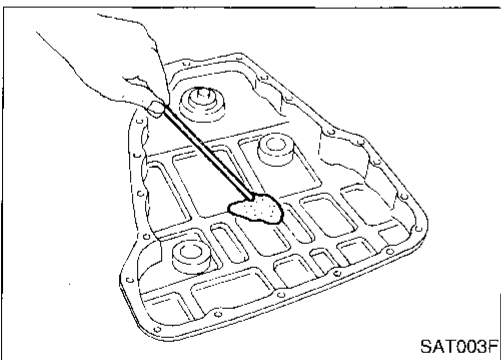

18. Install oil pan.
 - a. Attach a magnet to oil pan.
 - b. Install new oil pan gasket on transmission case.
 - c. Install oil pan on transmission case.
 - **Always replace oil pan bolts as they are self-sealing bolts.**
 - **Tighten four bolts in a criss-cross pattern to prevent dislocation of gasket.**
 - d. Tighten oil pan bolts and drain plug to the specified torque. Refer to AT-212.

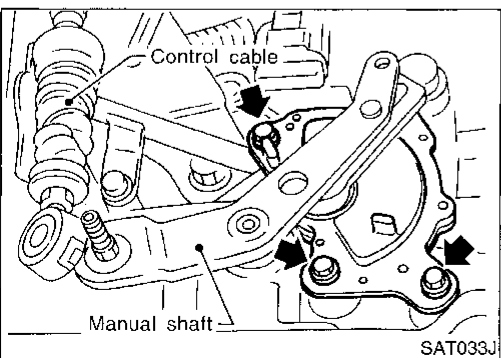

19. Install inhibitor switch.
 - a. Set manual shaft in "P" position.
 - b. Temporarily install inhibitor switch on manual shaft.
 - c. Move selector lever to "N" position.

ASSEMBLY

Assembly 3 (Cont'd)

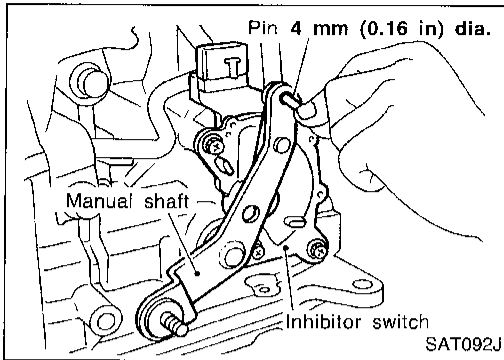

- d. Use a 4 mm (0.16 in) pin for this adjustment.
 - 1) Insert the pin straight into the manual shaft adjustment hole.
 - 2) Rotate inhibitor switch until the pin can also be inserted straight into hole in inhibitor switch.
- e. Tighten inhibitor switch fixing bolts. Refer to AT-212.
- f. Remove pin from adjustment hole after adjusting inhibitor switch.

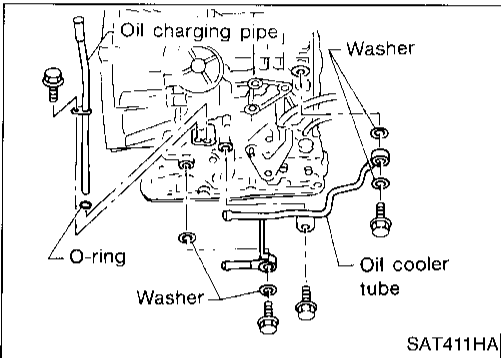

20. Install oil charging pipe and oil cooler tube to transmission case.

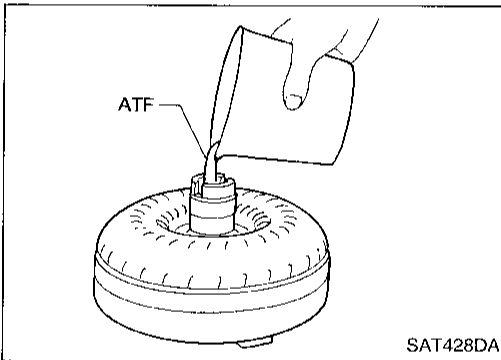

21. Install torque converter.
 - a. Pour ATF into torque converter.
 - **Approximately 1 liter (1-1/8 US qt, 7/8 Imp qt) of fluid is required for a new torque converter.**
 - **When reusing old torque converter, add the same amount of fluid as was drained.**

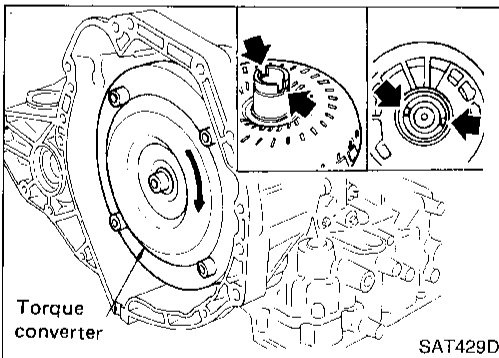

- b. Install torque converter while aligning notches of torque converter with notches of oil pump.

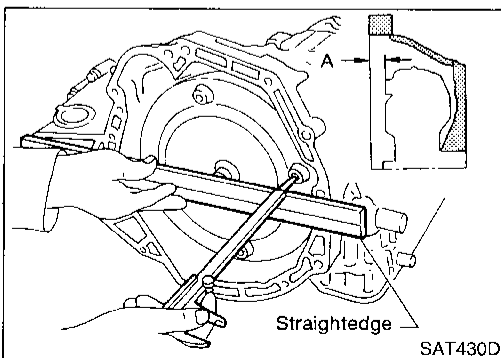

- c. Measure distance "A" to check that torque converter is in proper position.

Distance A: 19 mm (0.75 in) or more

SERVICE DATA AND SPECIFICATIONS (SDS)

General Specifications

Engine	KA24DE
Automatic transaxle model	RE4F04A
Automatic transaxle assembly	
Model code number	80X67
Transaxle gear ratio	
1st	2.785
2nd	1.545
3rd	1.000
4th	0.694
Reverse	2.272
Final drive	3.619
Recommended oil	Nissan Matic D (Continental U.S. and Alaska) or Genuine Nissan Automatic Transmission Fluid (Canada)*
Oil capacity ℓ (US qt, Imp qt)	9.4 (10, 8-1/4)

*: Refer to MA section ("Fluids and Lubricants", "RECOMMENDED FLUIDS AND LUBRICANTS").

Specifications and Adjustments

SHIFT SCHEDULE

Vehicle speed when shifting gears

Throttle position	Shift pattern	Vehicle speed km/h (MPH)						
		D ₁ → D ₂	D ₂ → D ₃	D ₃ → D ₄	D ₄ → D ₃	D ₃ → D ₂	D ₂ → D ₁	1 ₂ → 1 ₁
Full throttle	Comfort	57 - 65 (35 - 40)	107 - 115 (66 - 71)	167 - 175 (104 - 109)	163 - 171 (101 - 106)	97 - 105 (60 - 65)	41 - 49 (25 - 30)	57 - 65 (35 - 40)
Half throttle	Comfort	33 - 41 (21 - 25)	60 - 68 (37 - 42)	141 - 149 (88 - 93)	95 - 103 (59 - 64)	40 - 48 (25 - 30)	5 - 13 (3 - 8)	57 - 65 (35 - 40)

Vehicle speed when performing lock-up

Throttle position	Shift pattern	O/D switch	Gear position	Vehicle speed km/h (MPH)	
				Lock-up ON	Lock-up OFF
2/8	Comfort	ON	D ₄	95 - 103 (59 - 64)	61 - 69 (38 - 43)
		OFF	D ₃	86 - 94 (53 - 58)	83 - 91 (52 - 57)

STALL REVOLUTION

Engine	Stall revolution rpm
KA24DE	2,150 - 2,450

LINE PRESSURE

Engine speed rpm	Line pressure kPa (kg/cm ² , psi)	
	D, 2 and 1 positions	R position
Idle	804 (8.2, 117)	1,245 (12.7, 181)
Stall	1,236 (12.6, 179)	1,922 (19.6, 279)

SERVICE DATA AND SPECIFICATIONS (SDS)

Specifications and Adjustments (Cont'd)

CONTROL VALVES

Control valve and plug return springs

Unit: mm (in)

	Parts		Item		
			Part No.	Free length	Outer diameter
Upper body	⑱	Pilot valve spring	31742-80X14	36.0 (1.417)	8.1 (0.319)
	⑧	1-2 accumulator valve spring	31742-80X10	20.5 (0.807)	7.0 (0.276)
	⑳	1-2 accumulator piston spring	31742-80X19	49.3 (1.941)	19.6 (0.772)
	㉕	1st reducing valve spring	31742-80X05	27.0 (1.063)	7.0 (0.276)
	⑯	Overrun clutch reducing valve spring	31742-80X15	37.5 (1.476)	6.9 (0.272)
	⑪	Torque converter relief valve spring	31742-80X07	31.0 (1.220)	9.0 (0.354)
	④	Torque converter clutch control valve	31742-80X17	39.5 (1.555)	11.0 (0.433)
Lower body	⑰	Pressure regulator valve spring	31742-80X13	45.0 (1.772)	15.0 (0.591)
	㉒	Overrun clutch control valve spring	31762-80X00	21.7 (0.854)	7.0 (0.276)
	㉖	Accumulator control valve spring	31742-80X02	22.0 (0.866)	6.5 (0.256)
	⑳	Shift valve A spring	31762-80X00	21.7 (0.854)	7.0 (0.276)
	⑫	Shift valve B spring	31762-80X00	21.7 (0.854)	7.0 (0.276)
	③	Pressure modifier valve spring	31742-41X15	30.5 (1.201)	9.8 (0.386)
	⑦		31742-80X16	32.0 (1.260)	6.9 (0.272)
		⑭	Plug spring	31742-80X11	17.0 (0.669)

SERVICE DATA AND SPECIFICATIONS (SDS)

Specifications and Adjustments (Cont'd)

CLUTCHES AND BRAKES

Reverse clutch		
Number of drive plates	2	
Number of driven plates	2	
Drive plate thickness mm (in)		
Standard	1.6 (0.063)	
Allowable limit	1.4 (0.055)	
Clearance mm (in)		
Standard	0.5 - 0.8 (0.020 - 0.031)	
Allowable limit	1.2 (0.047)	
Thickness of retaining plates	Thickness mm (in)	Part number
	6.6 (0.260)	31537-80X05
	6.8 (0.268)	31537-80X06
	7.0 (0.276)	31537-80X07
	7.2 (0.283)	31537-80X08
	7.4 (0.291)	31537-80X09
	7.6 (0.299)	31537-80X20
	7.8 (0.307)	31537-80X21
	High clutch	
Number of drive plates	3	
Number of driven plates	7 + 1	
Drive plate thickness mm (in)		
Standard	1.6 (0.063)	
Allowable limit	1.4 (0.055)	
Clearance mm (in)		
Standard	1.8 - 2.2 (0.071 - 0.087)	
Allowable limit	2.8 (0.110)	
Thickness of retaining plates	Thickness mm (in)	Part number
	3.2 (0.126)	31537-80X11
	3.4 (0.134)	31537-80X12
	3.6 (0.142)	31537-80X13
	3.8 (0.150)	31537-80X14
	4.0 (0.157)	31537-80X15

Forward clutch		
Number of drive plates	5	
Number of driven plates	5	
Drive plate thickness mm (in)		
Standard	1.6 (0.063)	
Allowable limit	1.4 (0.055)	
Clearance mm (in)		
Standard	0.45 - 0.85 (0.0177 - 0.0335)	
Allowable limit	1.85 (0.0728)	
Thickness of retaining plates	Thickness mm (in)	Part number
	3.6 (0.142)	31537-80X70
	3.8 (0.150)	31537-80X71
	4.0 (0.157)	31537-80X72
	4.2 (0.165)	31537-80X73
	4.4 (0.173)	31537-80X74
	3.4 (0.134)	31537-80X75
3.2 (0.126)	31537-80X76	
Overrun clutch		
Number of drive plates	3	
Number of driven plates	5	
Drive plate thickness mm (in)		
Standard	1.6 (0.063)	
Allowable limit	1.4 (0.055)	
Clearance mm (in)		
Standard	0.7 - 1.1 (0.028 - 0.043)	
Allowable limit	1.7 (0.067)	
Thickness of retaining plates	Thickness mm (in)	Part number
	3.0 (0.118)	31537-80X65
	3.2 (0.126)	31537-80X66
	3.4 (0.134)	31537-80X67
	3.6 (0.142)	31537-80X68
3.8 (0.150)	31537-80X69	

GI
 MA
 EM
 LC
 EC
 FE
 CL
 MT
AT
 FA
 RA
 BR
 ST
 RS
 BT
 HA
 EL
 IDX

SERVICE DATA AND SPECIFICATIONS (SDS)

Specifications and Adjustments (Cont'd)

Low & reverse brake		
Number of drive plates	6	
Number of driven plates	6	
Drive plate thickness mm (in)		
Standard	1.8 (0.071)	
Allowable limit	1.6 (0.063)	
Clearance mm (in)		
Standard	1.7 - 2.1 (0.067 - 0.083)	
Allowable limit	3.3 (0.130)	
Thickness of retaining plates	Thickness mm (in)	Part number
	2.0 (0.079)	31667-80X00
	2.2 (0.087)	31667-80X01
	2.4 (0.094)	31667-80X02
	2.6 (0.102)	31667-80X03
	2.8 (0.110)	31667-80X04
	3.0 (0.118)	31667-80X05
	3.2 (0.126)	31667-80X06
	3.4 (0.134)	31667-80X07
9.0 (0.354)	31677-80X09	
Brake band		
Anchor end pin tightening torque N-m (kg-m, in-lb)	3.9 - 5.9 (0.4 - 0.6, 35 - 52)	
Number of returning revolutions for anchor end pin	2.5	
Lock nut tightening torque N-m (kg-m, ft-lb)	31 - 36 (3.2 - 3.7, 23 - 27)	

FINAL DRIVE

Differential side gear clearance

Clearance between side gear and differential case with washer mm (in)	0.1 - 0.2 (0.004 - 0.008)
--	---------------------------

Differential side gear thrust washers

Thickness mm (in)	Part number
0.75 (0.0295)	38424-81X00
0.80 (0.0315)	38424-81X01
0.85 (0.0335)	38424-81X02
0.90 (0.0354)	38424-81X03
0.95 (0.0374)	38424-81X04

Differential side bearing preload adjusting shims

Thickness mm (in)	Part number
0.48 (0.0189)	31438-80X00
0.52 (0.0205)	31438-80X01
0.56 (0.0220)	31438-80X02
0.60 (0.0236)	31438-80X03
0.64 (0.0252)	31438-80X04
0.68 (0.0268)	31438-80X05
0.72 (0.0283)	31438-80X06
0.76 (0.0299)	31438-80X07
0.80 (0.0315)	31438-80X08
0.84 (0.0331)	31438-80X09
0.88 (0.0346)	31438-80X10
0.92 (0.0362)	31438-80X11

Bearing preload

Differential side bearing preload mm (in)	0.05 - 0.09 (0.0020 - 0.0035)
--	-------------------------------

Turning torque

Turning torque of final drive assembly (New bearing) N-m (kg-cm, in-lb)	0.78 - 1.37 (8.0 - 14.0, 6.9 - 12.2)
--	--------------------------------------

Clutch and brake return springs

Unit: mm (in)

Parts	Free length	Outer diameter
Forward clutch (Overrun clutch) (22 pcs)	21.4 (0.843)	10.3 (0.406)
High clutch (12 pcs)	22.5 (0.886)	10.8 (0.425)
Low & Reverse brake (24 pcs)	24.1 (0.949)	6.6 (0.260)

SERVICE DATA AND SPECIFICATIONS (SDS)

Specifications and Adjustments (Cont'd)

PLANETARY CARRIER AND OIL PUMP

Planetary carrier		
Clearance between planetary carrier and pinion washer	mm (in)	
Standard		0.20 - 0.70 (0.0079 - 0.0276)
Allowable limit		0.80 (0.0315)
Oil pump		
Oil pump side clearance	mm (in)	0.030 - 0.050 (0.0012 - 0.0020)
Thickness of inner gears and outer gears	Inner gear	
	Thickness mm (in)	Part number
	11.99 - 12.0 (0.4720 - 0.4724)	31346-80X00
	11.98 - 11.99 (0.4717 - 0.4720)	31346-80X01
	11.97 - 11.98 (0.4713 - 0.4717)	31346-80X02
	Outer gear	
	Thickness mm (in)	Part number
	11.99 - 12.0 (0.4720 - 0.4724)	31347-80X00
	11.98 - 11.99 (0.4717 - 0.4720)	31347-80X01
	11.97 - 11.98 (0.4713 - 0.4717)	31347-80X02
Clearance between oil pump housing and outer gear	mm (in)	
Standard		0.111 - 0.181 (0.0044 - 0.0071)
Allowable limit		0.181 (0.0071)
Oil pump cover seal ring clearance	mm (in)	
Standard		0.10 - 0.25 (0.0039 - 0.0098)
Allowable limit		0.25 (0.0098)

INPUT SHAFT

Input shaft seal ring clearance	mm (in)	
Standard		0.08 - 0.23 (0.0031 - 0.0091)
Allowable limit		0.23 (0.0091)

REDUCTION PINION GEAR

Turning torque

Turning torque of reduction pinion gear	0.05 - 0.39
N-m (kg-cm, in-lb)	(0.5 - 4.0, 0.43 - 3.47)

Reduction pinion gear bearing adjusting shims

Thickness mm (in)	Part number
4.50 (0.1772)	31439-33X00
4.52 (0.1780)	31439-33X01
4.54 (0.1787)	31439-33X02
4.56 (0.1795)	31439-33X03
4.58 (0.1803)	31439-33X04
4.60 (0.1811)	31439-33X05
4.62 (0.1819)	31439-33X06
4.64 (0.1827)	31439-33X07
4.66 (0.1835)	31439-33X08
4.68 (0.1843)	31439-33X09
4.70 (0.1850)	31439-33X10
4.72 (0.1858)	31439-33X11
4.74 (0.1866)	31439-33X12
4.76 (0.1874)	31439-33X13
4.78 (0.1882)	31439-33X14
4.80 (0.1890)	31439-33X15
4.82 (0.1898)	31439-33X16
4.84 (0.1906)	31439-33X17
4.86 (0.1913)	31439-33X18
4.88 (0.1921)	31439-33X19
4.90 (0.1929)	31439-33X20
4.92 (0.1937)	31439-33X21
4.94 (0.1945)	31439-33X22
4.96 (0.1953)	31439-33X23
4.98 (0.1961)	31439-33X24
5.00 (0.1969)	31439-81X00
5.02 (0.1976)	31439-81X01
5.04 (0.1984)	31439-81X02
5.06 (0.1992)	31439-81X03
5.08 (0.2000)	31439-81X04
5.10 (0.2008)	31439-81X05
5.12 (0.2016)	31439-81X06
5.14 (0.2024)	31439-81X07
5.16 (0.2031)	31439-81X08
5.18 (0.2039)	31439-81X09
5.20 (0.2047)	31439-81X10
5.22 (0.2055)	31439-81X11
5.24 (0.2063)	31439-81X12
5.26 (0.2071)	31439-81X13
5.28 (0.2079)	31439-81X14
5.30 (0.2087)	31439-81X15
5.32 (0.2094)	31439-81X16
5.34 (0.2102)	31439-81X17
5.36 (0.2110)	31439-81X18
5.38 (0.2118)	31439-81X19
5.40 (0.2126)	31439-81X20
5.42 (0.2134)	31439-81X21
5.44 (0.2142)	31439-81X22
5.46 (0.2150)	31439-81X23
5.48 (0.2157)	31439-81X24
5.50 (0.2165)	31439-81X46
5.52 (0.2173)	31439-81X47
5.54 (0.2181)	31439-81X48
5.56 (0.2189)	31439-81X49

GI
MA
EM
LC
EC
FE
CL
MT
AT
FA
RA
BR
ST
RS
BT
HA
EL
IDX

SERVICE DATA AND SPECIFICATIONS (SDS)

Specifications and Adjustments (Cont'd)

5.58 (0.2197)	31439-81X60
5.60 (0.2205)	31439-81X61
5.62 (0.2213)	31439-81X62
5.64 (0.2220)	31439-81X63
5.66 (0.2228)	31439-81X64
5.68 (0.2236)	31439-81X65
5.70 (0.2244)	31439-81X66
5.72 (0.2252)	31439-81X67
5.74 (0.2260)	31439-81X68
5.76 (0.2268)	31439-81X69
5.78 (0.2276)	31439-81X70
5.80 (0.2283)	31439-81X71
5.82 (0.2291)	31439-81X72
5.84 (0.2299)	31439-81X73
5.86 (0.2307)	31439-81X74
5.88 (0.2315)	31439-81X75
5.90 (0.2323)	31439-81X76
5.92 (0.2331)	31439-81X77
5.94 (0.2339)	31439-81X78
5.96 (0.2346)	31439-81X79
5.98 (0.2354)	31439-81X80
6.00 (0.2362)	31439-81X81

REVERSE CLUTCH DRUM END PLAY

Reverse clutch drum end play mm (in)	0.55 - 0.90 (0.0217 - 0.0354)
---	-------------------------------

Thrust washers for adjusting reverse clutch drum end play

Thickness mm (in)	Part number
0.80 (0.0315)	31508-80X13
1.40 (0.0551)	31508-80X17
0.95 (0.0374)	31508-80X14
1.10 (0.0433)	31508-80X15
1.25 (0.0492)	31508-80X16
1.55 (0.0610)	31508-80X18
1.70 (0.0669)	31508-80X19
1.85 (0.0728)	31508-80X20

ACCUMULATOR

O-ring

Unit: mm (in)

Accumulator	Inner diameter (Small)	Inner diameter (Large)
Servo release accumulator	26.9 (1.059)	44.2 (1.740)
N-D accumulator	34.6 (1.362)	39.4 (1.551)

Return spring

Unit: mm (in)

Accumulator	Free length	Outer diameter
Servo release accumulator	52.5 (2.067)	20.4 (0.803)
N-D accumulator	43.5 (1.713)	28.0 (1.102)

BAND SERVO

Return spring

Unit: mm (in)

Return spring	Free length	Outer diameter
2nd servo return spring	32.5 (1.280)	25.9 (1.020)
O/D servo return spring	31.0 (1.220)	21.7 (0.854)

REMOVAL AND INSTALLATION

Unit: mm (in)

Distance between end of converter housing and torque converter	19 (0.75)
--	-----------

OUTPUT SHAFT

Seal ring clearance

Output shaft seal ring clearance mm (in)	
Standard	0.10 - 0.25 (0.0039 - 0.0098)
Allowable limit	0.25 (0.0098)

End play

Output shaft end play mm (in)	0 - 0.15 (0 - 0.0059)
----------------------------------	-----------------------

Output shaft end play adjusting shims

Thickness mm (in)	Part number
0.80 (0.0315)	31438-80X60
0.84 (0.0331)	31438-80X61
0.88 (0.0346)	31438-80X62
0.92 (0.0362)	31438-80X63
0.96 (0.0378)	31438-80X64
1.00 (0.0394)	31438-80X65
1.04 (0.0409)	31438-80X66
1.08 (0.0425)	31438-80X67
1.12 (0.0441)	31438-80X68
1.16 (0.0457)	31438-80X69
1.20 (0.0472)	31438-80X70

SERVICE DATA AND SPECIFICATIONS (SDS)

Specifications and Adjustments (Cont'd)

BEARING RETAINER

Seal ring clearance

Bearing retainer seal ring clearance mm (in)	
Standard	0.10 - 0.30 (0.0039 - 0.0118)
Allowable limit	0.30 (0.0118)

TOTAL END PLAY

Total end play	mm (in)	0.25 - 0.55 (0.0098 - 0.0217)
----------------	---------	-------------------------------

Bearing race for adjusting total end play

Thickness mm (in)	Part number
0.8 (0.031)	31435-80X00
1.0 (0.039)	31435-80X01
1.2 (0.047)	31435-80X02
1.4 (0.055)	31435-80X03
1.6 (0.063)	31435-80X04
1.8 (0.071)	31435-80X05
2.0 (0.079)	31435-80X06
0.9 (0.035)	31435-80X09
1.1 (0.043)	31435-80X10
1.3 (0.051)	31435-80X11
1.5 (0.059)	31435-80X12
1.7 (0.067)	31435-80X13
1.9 (0.075)	31435-80X14

GI
 MA
 EM
 LC
 EC
 FE
 CL
 MT
AT
 FA
 RA
 BR
 ST
 RS
 BT
 HA
 EL
 IX