

RESTRAINT SYSTEM

SECTION **RS**

CONTENTS

PRECAUTION	2	Disposal of Air Bag Module	15
Supplemental Restraint System (SRS) "AIR BAG"	2	Checking Deployment Tool.....	15
SEAT BELTS	3	Deployment Procedures For Air Bag Module (Outside of vehicle)	16
Front Seat Belt.....	4	Deployment of Air Bag Module While Mounted In Vehicle	18
Removal.....	5	Disposing of Air Bag Module.....	18
Rear Seat Belt	6	TROUBLE DIAGNOSES — Supplemental Restraint System (SRS)	19
Removal.....	6	Wiring Diagram –SRS–	19
SUPPLEMENTAL RESTRAINT SYSTEM (SRS)	7	Schematic	21
Precautions for SRS "Air Bag" Service.....	7	How to Perform Trouble Diagnoses for Quick and Accurate Repair	22
Special Service Tools.....	7	Self-diagnosis.....	24
Description	8	Diagnostic Procedures	24
SRS Component Parts Location.....	8	Trouble Diagnoses for Air Bag Warning Lamp	38
Maintenance Items.....	9	Diagnostic Procedures	38
Removal and Installation — Diagnosis Sensor Unit.....	10	COLLISION DIAGNOSIS	40
Removal — Air Bag Module and Spiral Cable	11	SRS inspection.....	40
Installation — Air Bag Module and Spiral Cable.....	12		
Removal — Front Passenger Air Bag Module	13		
Installation — Front Passenger Air Bag Module	14		

When you read wiring diagrams:

- Read GI section, "HOW TO READ WIRING DIAGRAMS".
 - See EL section, "POWER SUPPLY ROUTING" for power distribution circuit.
- When you perform trouble diagnoses, read GI section, "HOW TO FOLLOW FLOW CHART IN TROUBLE DIAGNOSES" and "HOW TO PERFORM EFFICIENT DIAGNOSIS FOR AN ELECTRICAL INCIDENT".**

GI

MA

EM

LC

EC

FE

CL

MT

AT

FA

RA

BR

ST

RS

BT

HA

EL

IDX

PRECAUTION

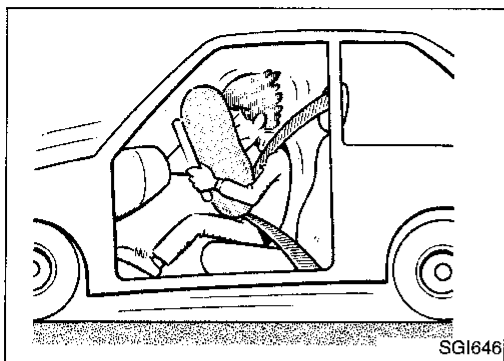

Supplemental Restraint System (SRS) "AIR BAG"

The Supplemental Restraint System "Air Bag", used along with a seat belt, helps to reduce the risk or severity of injury to the driver and front passenger in a frontal collision. The Supplemental Restraint System consists of air bag modules (located in the center of the steering wheel and on the instrument panel on the passenger side), a diagnosis sensor unit, warning lamp, wiring harness and spiral cable.

WARNING:

- To avoid rendering the SRS inoperative, which could increase the risk of personal injury or death in the event of a collision which would result in air bag inflation, all maintenance must be performed by an authorized NISSAN dealer.
- Improper maintenance, including incorrect removal and installation of the SRS, can lead to personal injury caused by unintentional activation of the system.
- Do not use electrical test equipment on any circuit related to the SRS unless instructed to in this Service Manual. SRS wiring harnesses are covered with yellow insulation either just before the harness connectors or for the complete harness, for easy identification.

SEAT BELTS

CAUTION:

- Do not disassemble buckle or seat belt assembly.
- Replace anchor bolts if they are deformed or worn out.
- Never oil tongue and buckle.
- If any component of seat belt assembly is questionable, do not repair. Replace the seat belt assembly.
- If webbing is cut, frayed, or damaged, replace seat belt assembly.
- When replacing seat belt assembly, use a genuine NISSAN seat belt assembly.
- After any collision, inspect all seat belt assemblies, including retractors and other attached hardware.

GI

MA

EM

LC

EC

FE

CL

MT

AT

FA

RA

BR

ST

RS

BT

HA

EL

IDX

SEAT BELTS

Front Seat Belt

SEC. 868

 43 - 55 (4.4 - 5.6, 32 - 41)

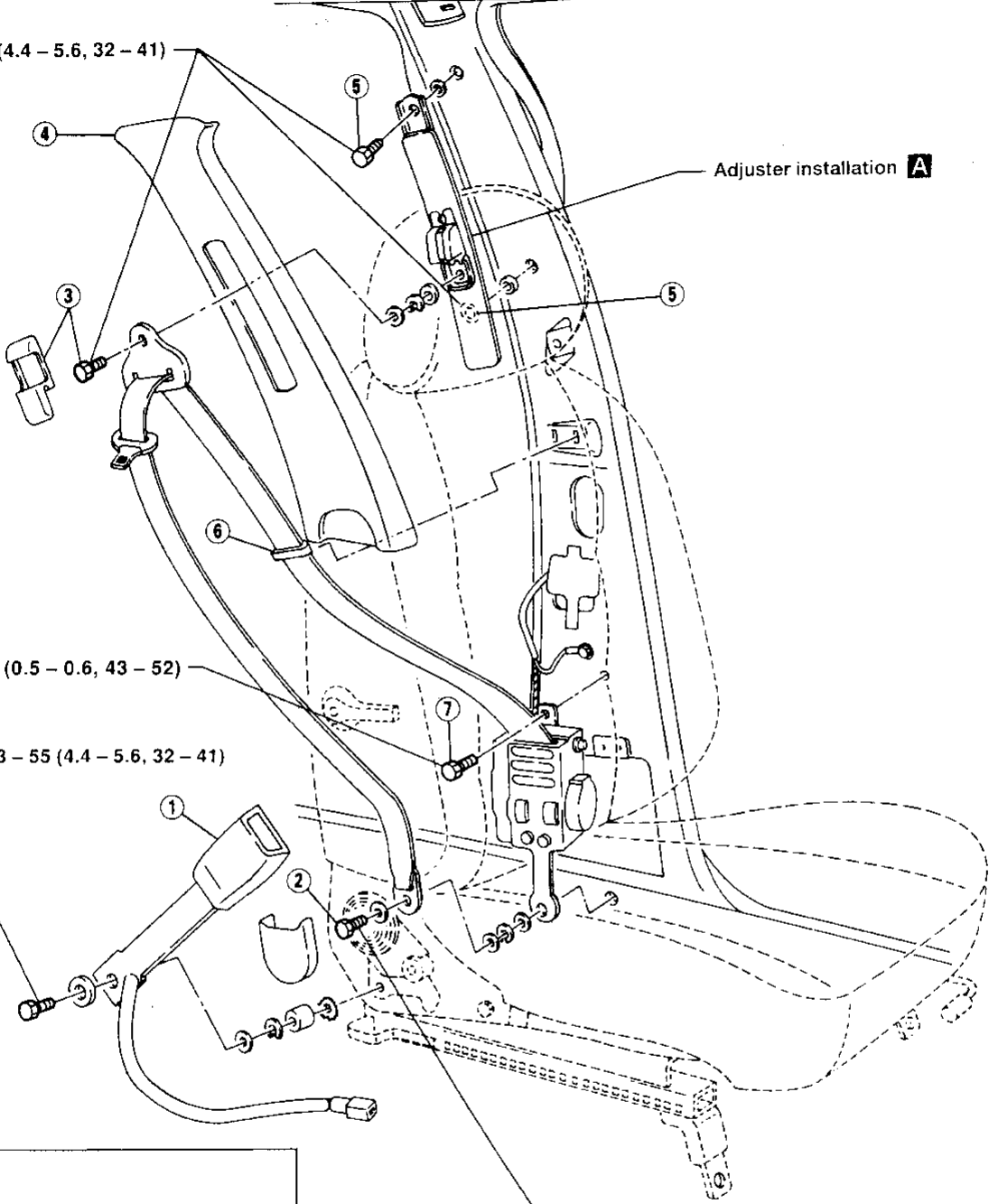



Adjuster installation **A**

 5.0 - 6.0 (0.5 - 0.6, 43 - 52)

 43 - 55 (4.4 - 5.6, 32 - 41)

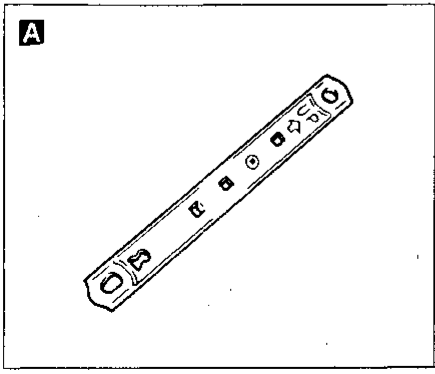
 43 - 55 (4.4 - 5.6, 32 - 41)



 : N·m (kg·m, ft·lb)

 : N·m (kg·m, in·lb)

ARS073

SEAT BELTS

Front Seat Belt (Cont'd)

REMOVAL

Remove front seat. Refer to BT section ("Front Seat", "SEAT").

- ① Remove buckle.
Remove front and rear kick plates.
- ② Remove floor anchor bolt.
Remove center pillar lower garnish.
- ③ Remove adjuster cover and pillar anchor bolt.
- ④ Remove center pillar upper garnish.
- ⑤ Remove two adjuster bolts and adjuster assembly. **A**
- ⑥ Remove guide plate.
- ⑦ Remove retractor bolt.
Remove retractor.

GI

MA

EM

LC

EC

FE

CL

MT

AT

FA

RA

BR

ST

RS

BT

HA

EL

IDX

SEAT BELTS

Rear Seat Belt

SEC. 869

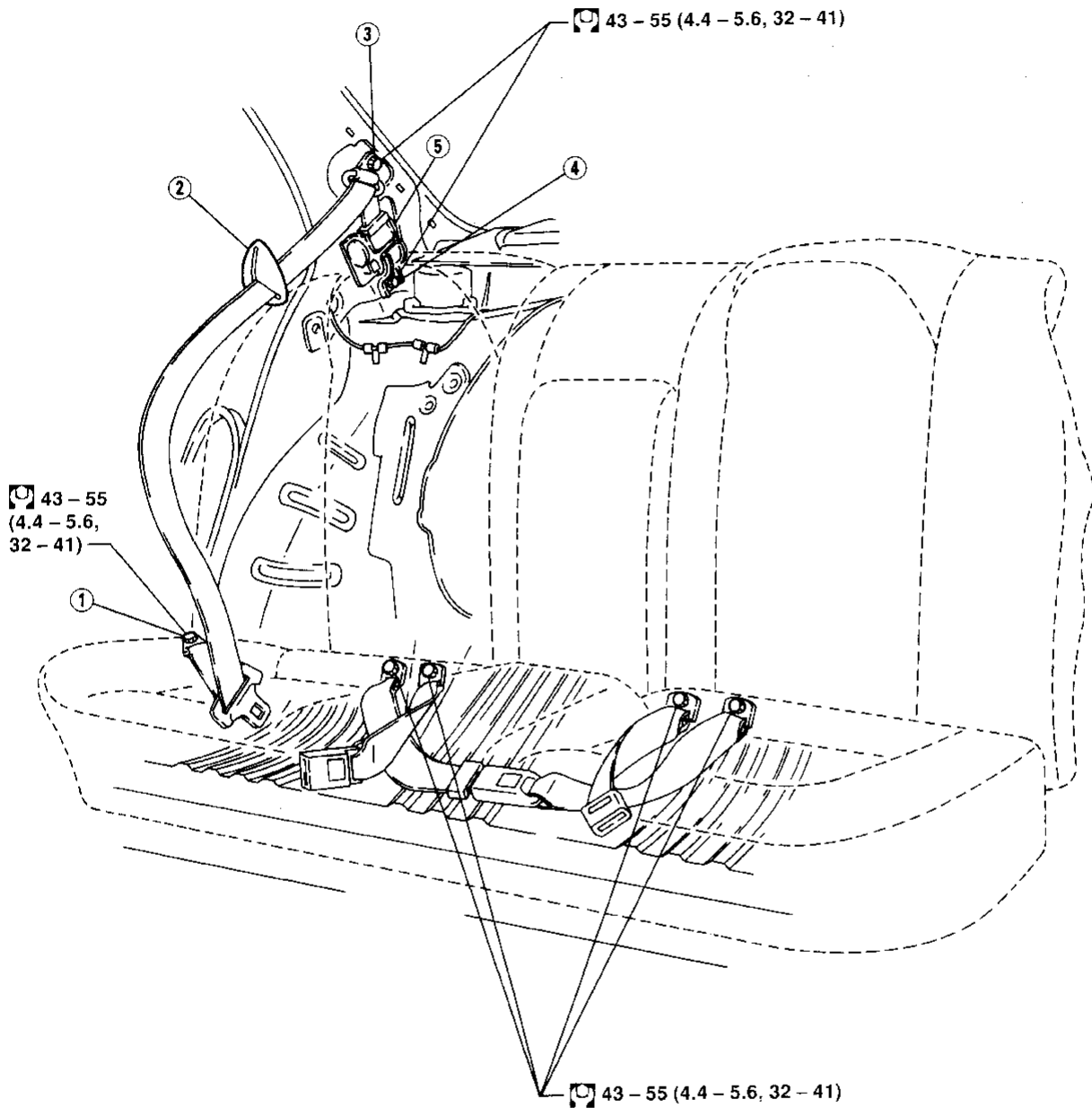

 : N-m (kg-m, ft-lb)

ARS074

REMOVAL

Remove rear seat cushion and rear seat back. Refer to BT section ("Rear Seat", "SEAT").

- ① Remove floor anchor bolt.
- ② Remove seat belt guide cover.
Remove rear pillar garnish.
- ③ Remove pillar anchor bolt.
- ④ Remove retractor bolts.
- ⑤ Remove retractor.

SUPPLEMENTAL RESTRAINT SYSTEM (SRS)

Precautions for SRS "Air Bag" Service

- Do not use a circuit tester to check SRS circuits.
- Before servicing the SRS, turn ignition switch "OFF", disconnect both battery cables and wait at least 10 minutes.
For approximately 10 minutes after the cables are removed, it is still possible for the air bag to deploy. Therefore, do not work on any air bag system connectors or wires until at least ten minutes have passed.
- Diagnosis sensor unit must always be installed with arrow mark "↗" pointing towards the front of the vehicle for proper operation. Also check diagnosis sensor unit for cracks, deformities or rust before installation and replace as required.
- The spiral cable must be aligned with the neutral position since its rotations are limited. Do not attempt to turn steering wheel or column after removal of steering gear.
- Handle air bag modules carefully. Always place them with the pad side facing upward.
- Do not use old bolts after removing any SRS parts; replace with new bolts. Conduct self-diagnosis to check entire SRS for proper function.
- After air bag inflates, the front instrument panel assembly should be replaced.

Special Service Tools

The actual shapes of Kent-Moore tools may differ from those of special service tools illustrated here.

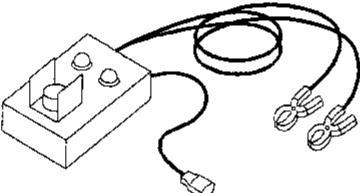
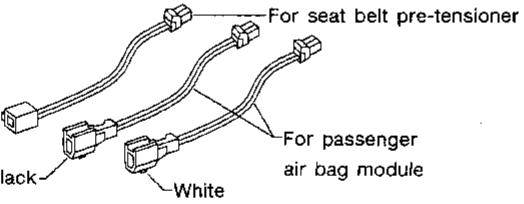
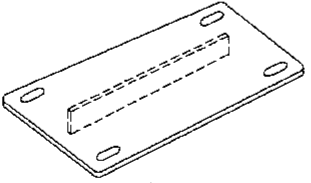
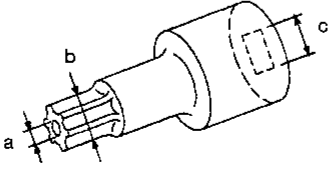
Tool number (Kent-Moore No.) Tool name	Description
KV991072S0 (J38381-KIT) Air bag deployment kit KV99106400 (J38381) Deployment tool	Disposing of air bag module  NT357
KV991065S0 (J38381-30) Deployment tool adapters	 NT353
KV99105300 (J41246) Passenger air bag bracket	Anchor the passenger air bag module  NT354
HT61961000 and HT62152000 combined (J38219) *Special torx bit	Use for special bolts [TAMPER RESISTANT TORX (Size T50)] a: 3.5 (0.138) dia. b: 8.5 - 8.6 (0.335 - 0.339) dia. c: approx. 10 (0.39) sq.  NT361

*: Special tool or commercial equivalent

SUPPLEMENTAL RESTRAINT SYSTEM (SRS)

Description

The air bags deploy if the diagnosis sensor unit activates while the ignition switch is in the "ON" or "START" position.

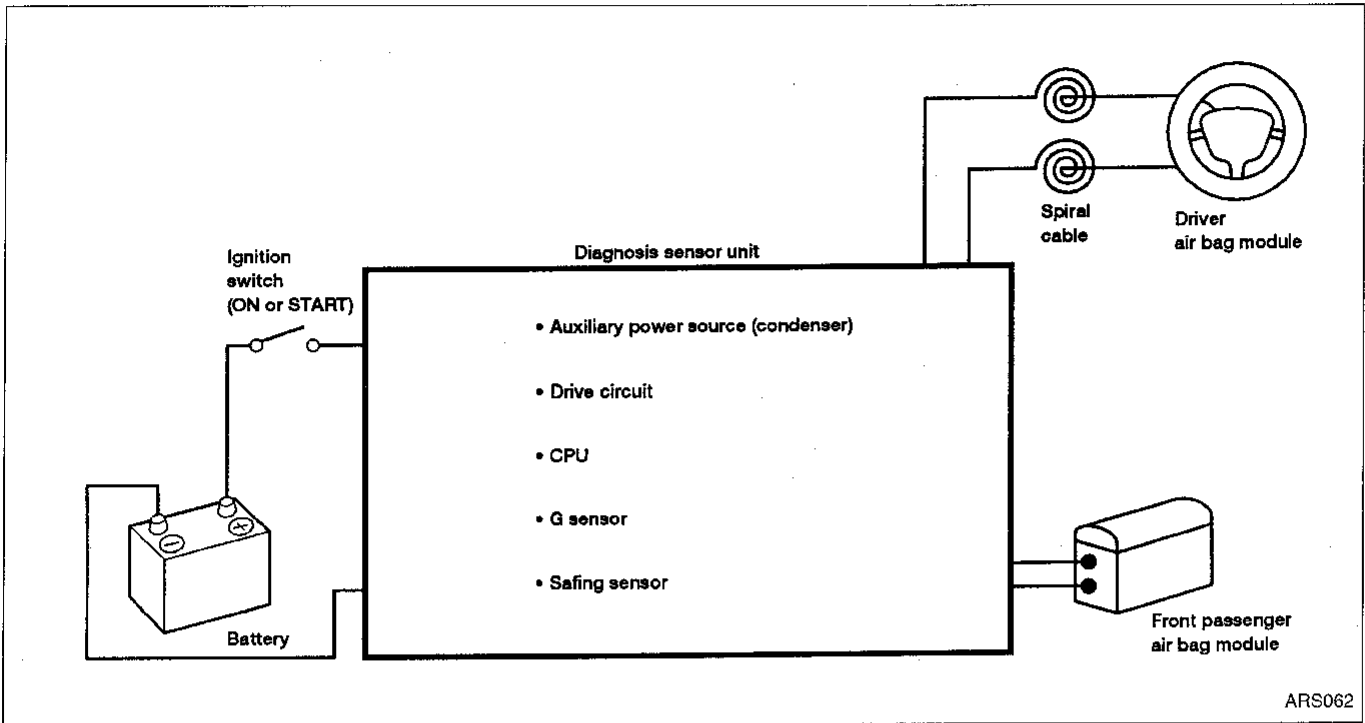

SRS Component Parts Location

SEC. 240-253-484-680

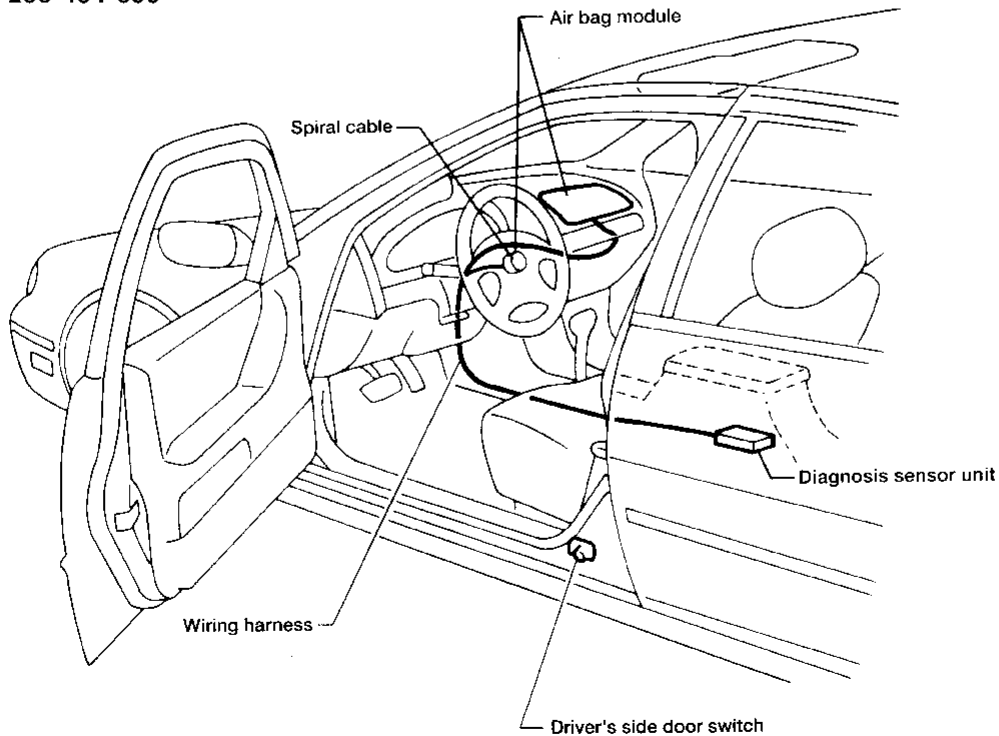

ARS078

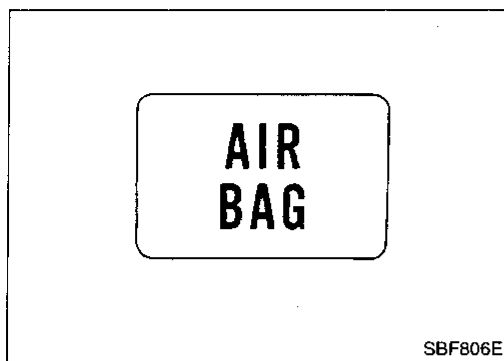

Maintenance Items

1. Check "AIR BAG" warning lamp operation
 - After turning ignition key to "ON" position, "AIR BAG" warning lamp illuminates. The "AIR BAG" warning lamp will turn off after about 7 seconds if no malfunction is detected. If any of the following air bag warning lamp conditions occur, immediately check the air bag system. Refer to RS-24 for details.
 - The warning lamp does not illuminate when the ignition switch is turned "ON".
 - The warning lamp does not turn off about 7 seconds after the ignition switch is turned "ON".
 - The warning lamp turns off about 7 seconds after the ignition switch is turned "ON", but it turns on again or blinks.

2. Visually check SRS components
 - (1) Diagnosis sensor unit
 - Check diagnosis sensor unit and bracket for dents, cracks or deformities.
 - Check connectors for damage, and terminals for deformities.

 - (2) Air bag module and steering wheel
 - Remove air bag module from steering wheel or instrument panel. Check harness cover and connectors for damage, terminals for deformities, and harness for binding.
 - Install driver side air bag module to steering wheel to check fit or alignment with the wheel.
 - Check steering wheel for excessive free play.
 - Install passenger side air bag module to instrument panel to check fit or alignment with the instrument panel.

 - (3) Spiral cable
 - Check spiral cable and combination switch for damage.
 - Check connectors and protective tape for damage.
 - Check steering wheel for noise, binding or heavy operation.

 - (4) Main harness and air bag harness
 - Check connectors for poor connections, damage, and terminals for deformities.
 - Check harnesses for binding, chafing or cut.

CAUTION:

Replace previously used special bolts with new ones.

GI

MA

EM

LC

EC

FE

CL

MT

AT

FA

RA

BR

ST

RS

BT

HA

EL

IDX

Removal and Installation — Diagnosis Sensor Unit

CAUTION:

- Before servicing SRS, turn the ignition switch off, disconnect both battery cables and wait at least 10 minutes.
 - The special bolts are coated with bonding agent while the other bolt is for ground. Do not use old bolts after removal; replace with new coated bolts.
 - Check diagnosis sensor unit for proper installation.
 - Check diagnosis sensor unit to ensure no deformities, dents, cracks or rust. If there are any visible signs of damage, replace with new one.
 - Check diagnosis sensor unit brackets to ensure they are free of deformities or rust.
1. Disconnect driver and passenger air bag module connectors.
 2. Remove console box. Refer to BT section (“INSTRUMENT PANEL”).
 3. Disconnect diagnosis sensor unit connector.
 4. Remove bolts from diagnosis sensor unit. Use TAMPER RESISTANT TORX (Size T50) to remove special bolts.
 5. Remove the diagnosis sensor unit.

NOTE:

To install, reverse the removal procedure sequence.

CAUTION:

Diagnosis sensor unit must always be installed with arrow marks “◀” pointing towards the front of the vehicle for proper operation. Also check diagnosis sensor unit for cracks, deformities or rust before installation and replace as required.

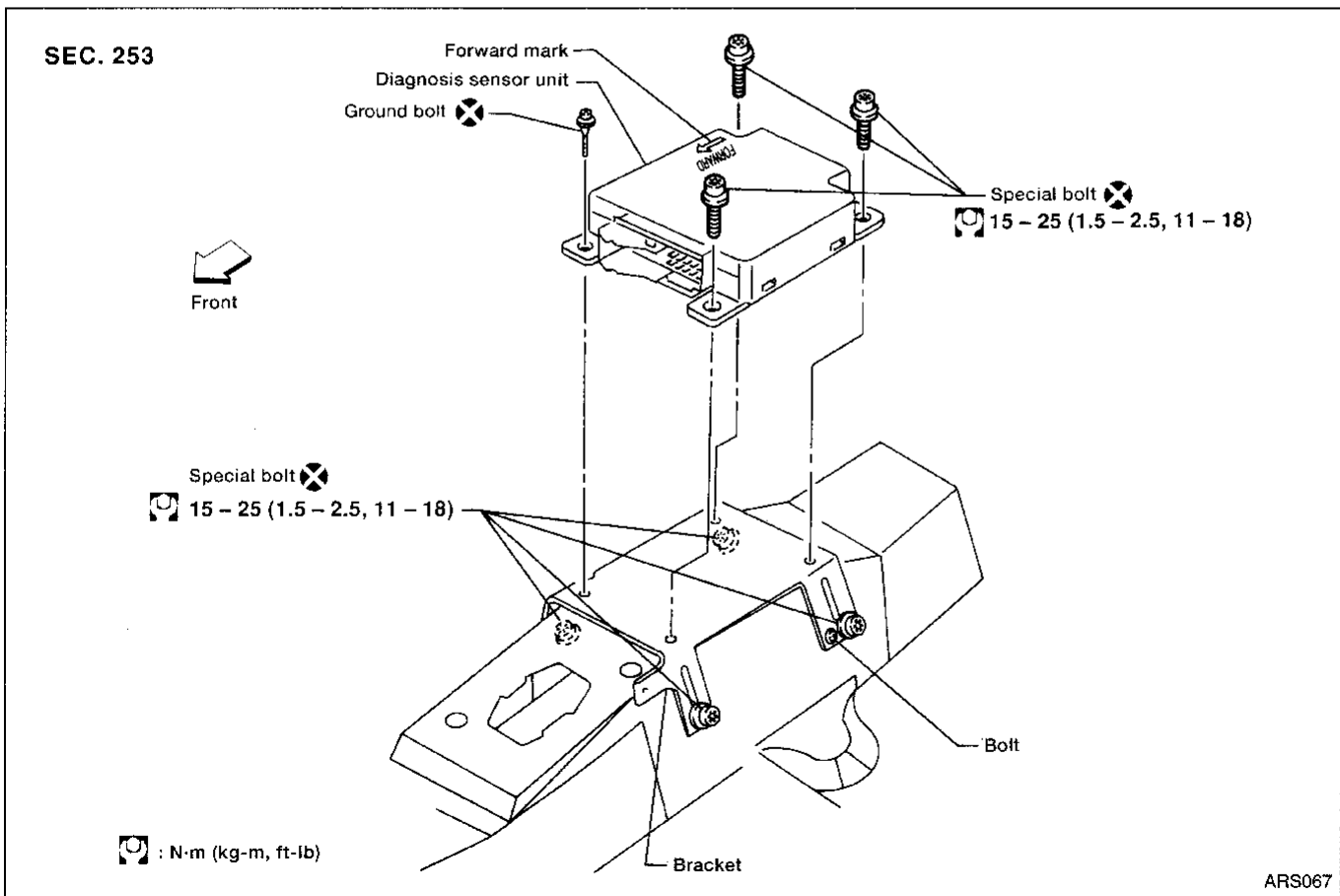

SUPPLEMENTAL RESTRAINT SYSTEM (SRS)

Removal — Air Bag Module and Spiral Cable

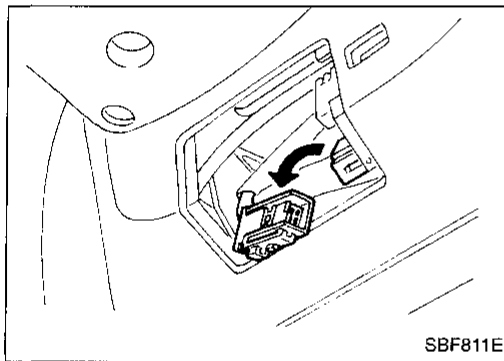
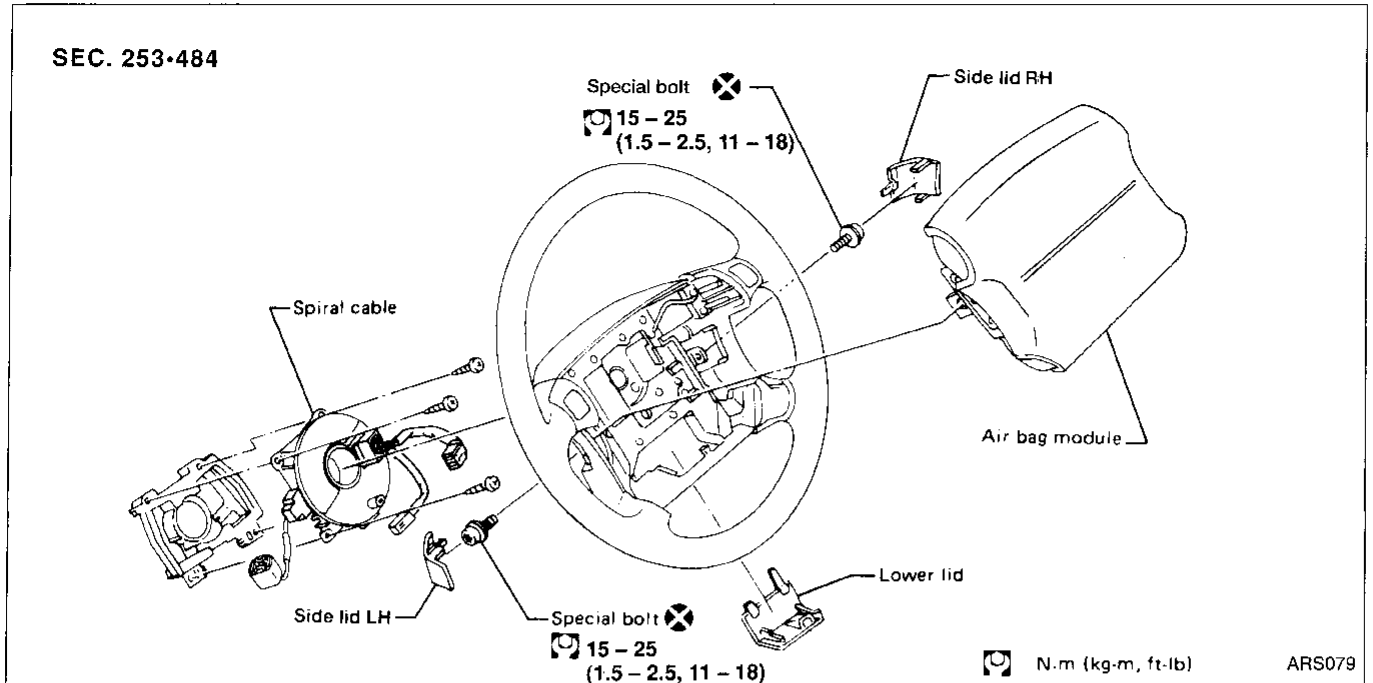

CAUTION:

Before servicing SRS, turn the ignition switch off, disconnect both battery cables and wait for at least 10 minutes.

1. Remove lower lid from steering wheel, and disconnect air bag module connector.

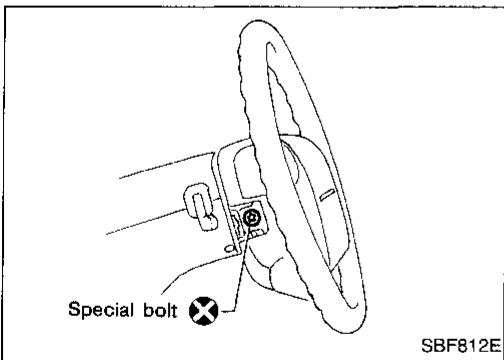

2. Remove side lid. Using the TAMPER RESISTANT TORX (Size T50), remove left and right special bolts. Air bag module can then be removed.

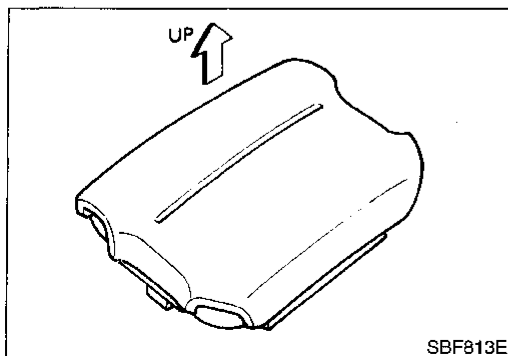

CAUTION:

- Always place air bag module with pad side facing upward.
- Do not attempt to disassemble air bag module.
- The special bolts are coated with bonding agent. Do not use old bolts after removal; replace with new coated bolts.

GI
MA
EM
LC
EC
FE
CL
MT
AT
FA
RA
BR
ST
RS
BT
HA
EL
IDX

SUPPLEMENTAL RESTRAINT SYSTEM (SRS)

Removal — Air Bag Module and Spiral Cable (Cont'd)

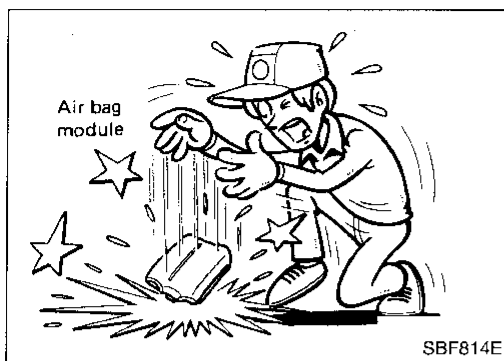

- Do not drop or impact air bag module. If any portion is deformed or cracked, replace the module.
- Do not expose the air bag module to temperatures exceeding 90°C (194°F).
- Do not allow oil, grease or water to come in contact with the air bag module.

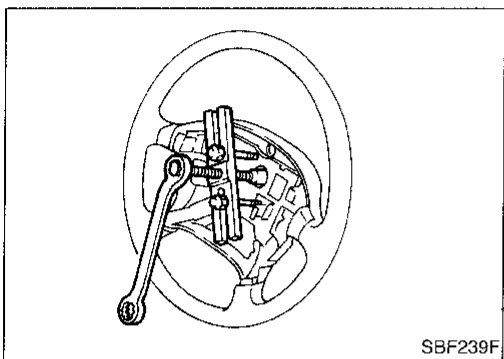

3. Set steering wheel in the neutral position.
4. Disconnect horn connector and remove nuts.
5. Using steering wheel puller, remove steering wheel. Be careful not to over-tighten puller bolt on steering wheel.

CAUTION:

Do not tap or bump the steering wheel.

6. Remove steering column cover.
7. Disconnect connector and remove the four screws. The spiral cable can then be removed.

CAUTION:

- Do not attempt to disassemble spiral cable.
- Do not apply lubricant to the spiral cable.

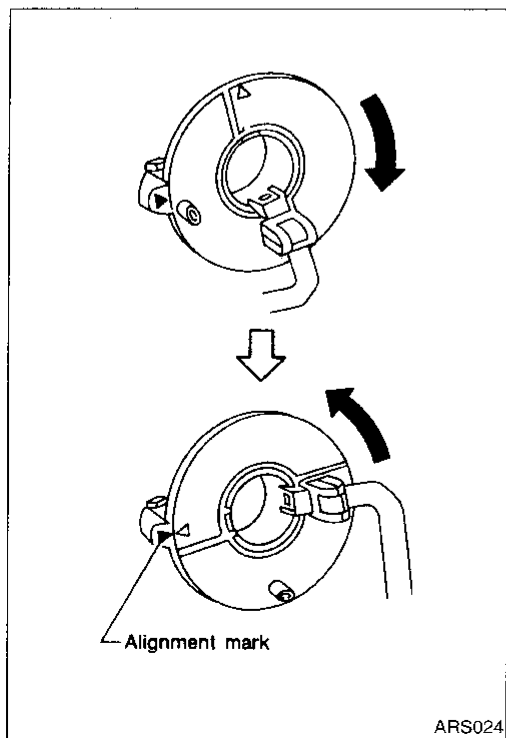

Installation — Air Bag Module and Spiral Cable

1. Set the front wheels in the straight-ahead position.
2. Make sure that the spiral cable is in the neutral position. The neutral position is detected by turning left 2.5 revolutions from the right end position. Align the two marks (X).

CAUTION:

The spiral cable may snap during steering operation if the cable is installed improperly. Also, with the steering linkage disconnected, the cable may snap by turning the steering wheel more than 2.5 turns to the left or right of the neutral position.

3. Connect spiral cable connector and tighten screws. Install steering column cover.

SUPPLEMENTAL RESTRAINT SYSTEM (SRS)

Installation — Air Bag Module and Spiral Cable (Cont'd)

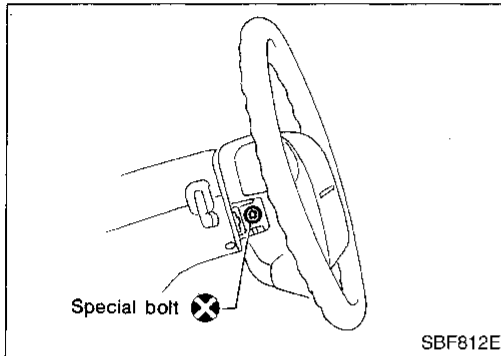
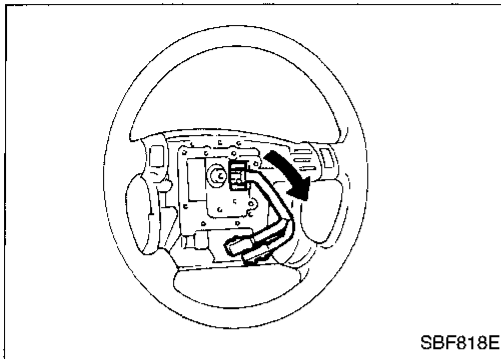

4. Install steering wheel setting spiral cable pin guides, and pull spiral cable through.
5. Release ignition key lock with battery cables disconnected. Turn steering wheel to the left end and then to the right end fully to make sure that spiral cable is set in the neutral position.
6. Connect horn connector and engage spiral cable with pawls in steering wheel.
7. Tighten nuts.
8. Position air bag module and tighten with new special bolts.
9. Connect air bag module connector.
10. Install ASCD switch and tighten screws.
11. Install all lids.
12. Connect both battery cables.
13. Conduct Self-diagnosis to ensure entire SRS operates properly. (Use CONSULT or warning lamp check.)
If air bag warning lamp blinks (at the user mode), it shows the spiral cable may be snapped due to its improper position. Perform self-diagnosis again (Use CONSULT or warning lamp check). If a malfunction is detected, replace the spiral cable with a new one.

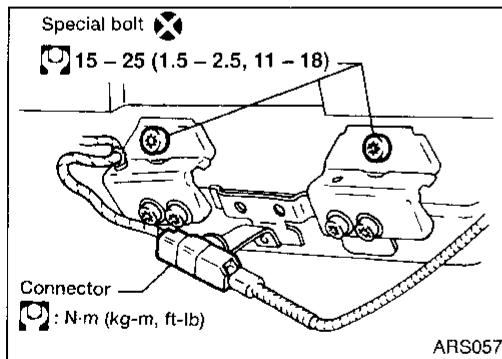

Removal — Front Passenger Air Bag Module

CAUTION:

Before servicing SRS, turn the ignition switch off, disconnect both battery cables and wait for at least ten minutes.

1. Remove glove box lid and glove box.
2. Disconnect passenger air bag module connector.
3. Using the TAMPER RESISTANT TORX (Size T50), remove two special bolts.

SUPPLEMENTAL RESTRAINT SYSTEM (SRS)

Removal — Front Passenger Air Bag Module (Cont'd)

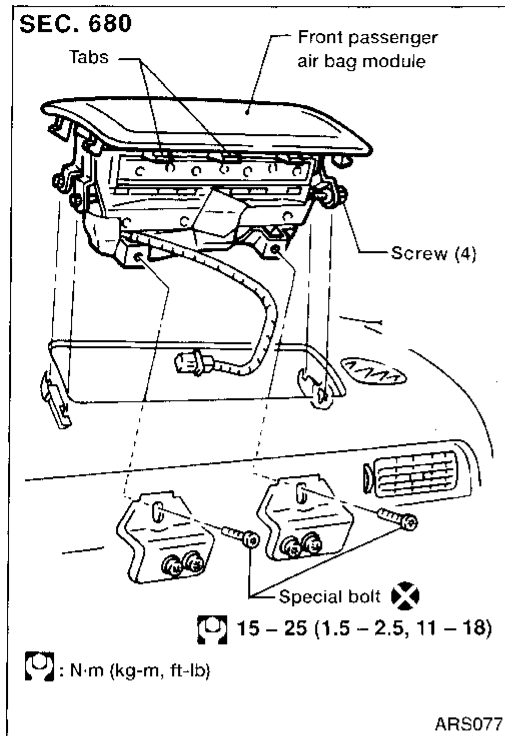

- Loosen the screws on left and right sides of front passenger air bag module.
- Remove air bag module by releasing the tabs from the top of the instrument panel.

- Air bag module is heavy and should be supported using both hands during removal.**

CAUTION:

- Always place air bag module with pad side facing upward.
- Do not attempt to disassemble air bag module.
- The special bolts are coated with bonding agent. Do not use old bolts after removal; replace with new coated bolts.
- Do not insert any foreign objects (screwdriver, etc.) into air bag module connector.

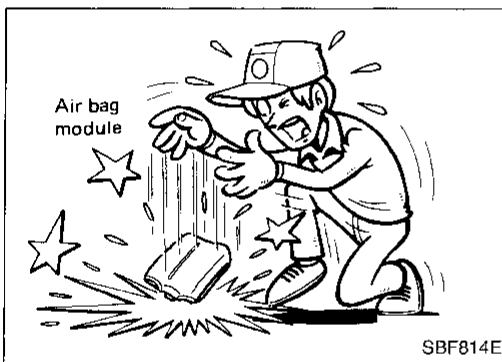

- Do not drop or impact air bag module. If any portion is deformed or cracked, replace the module.
- Do not expose the air bag module to temperatures exceeding 90°C (194°F).
- Do not allow oil, grease or water to come in contact with the air bag module.

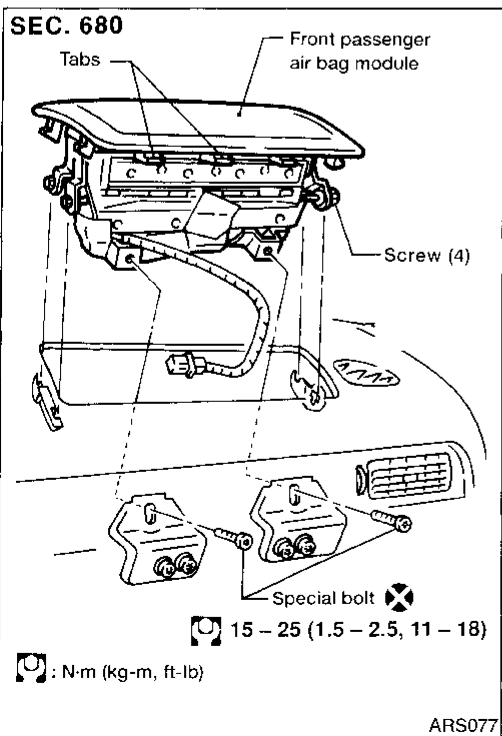

Installation — Front Passenger Air Bag Module

- Install front passenger air bag module in instrument panel.
 - Ensure harness is not caught between air bag module and support bracket.
 - Tighten four screws.
 - Install two new special bolts using TAMPER RESISTANT TORX (Size T50).

SUPPLEMENTAL RESTRAINT SYSTEM (SRS)

Installation — Front Passenger Air Bag Module (Cont'd)

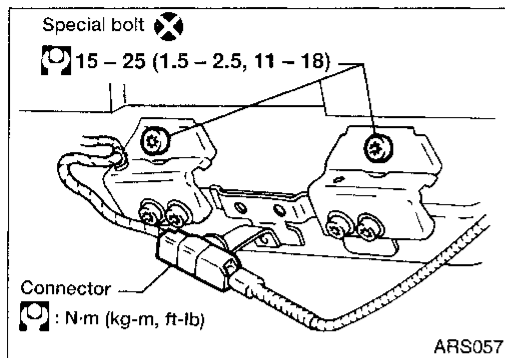

2. Connect inflator connector to air bag harness.
3. Install glove box and glove box lid.

Disposal of Air Bag Module

- Make sure to deactivate air bag modules before disposing them. Also, before disposing a vehicle equipped with an air bag system, deactivate air bag modules. If such a system has already been deployed due to an accident, dispose of as indicated in the section "DISPOSING OF AIR BAG MODULE".
- Do not dispose of the air bag module un-deployed.
- When deploying the air bag module, always use the Special Service Tool; Deployment tool (Kent-Moore No. J38381).
- When deploying the air bag module, stand at least 5 m (16 ft) away from the air bag module.
- Due to heat, do not touch air bag module for at least 30 minutes after deployment.
- Be sure to wear gloves when handling a deployed air bag module.
- Never apply water to a deployed air bag module.
- Wash your hands clean after finishing work.

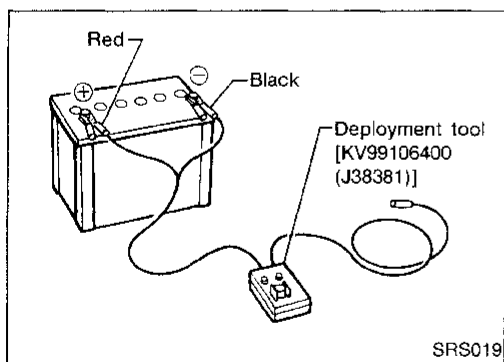

CHECKING DEPLOYMENT TOOL

Connecting to battery

- Place vehicle outdoors with at least 6 m (20 ft) of open space on all sides.
- Use a voltmeter to make sure the vehicle battery is fully charged.

CAUTION:

The battery must show voltage of 9.6V or more.

Remove the battery from the vehicle and place it on dry wood blocks approximately 5 m (16 ft) away from the vehicle.

- Wait 10 to 12 minutes after the vehicle battery is disconnected before proceeding.
- Connect red clip of deployment tool to battery positive terminal and black clip to negative terminal.

CAUTION:

Make sure the polarity is correct. The right side lamp in the tool, marked "deployment tool power", should glow with a green light. If the right side lamp glows red, reverse the connections to the battery.

SUPPLEMENTAL RESTRAINT SYSTEM (SRS)

Disposal of Air Bag Module (Cont'd)

Deployment tool check

Press the deployment tool switch to the "ON" position. The left side lamp in the tool, marked "air bag connector voltage" should illuminate. If it does not illuminate, replace the tool.

Air bag deployment tool lamp illumination chart (Battery connected)

Switch operation	Left side lamp, green* "AIR BAG CONNECTOR VOLTAGE"	Right side lamp, green* "DEPLOYMENT TOOL POWER"
OFF	OFF	ON
ON	ON	ON

*: If this lamp glows red, the tool is connected to the battery incorrectly. Reverse the connections and make sure the lamp glows green.

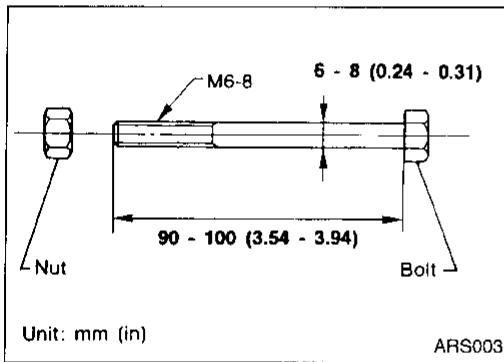
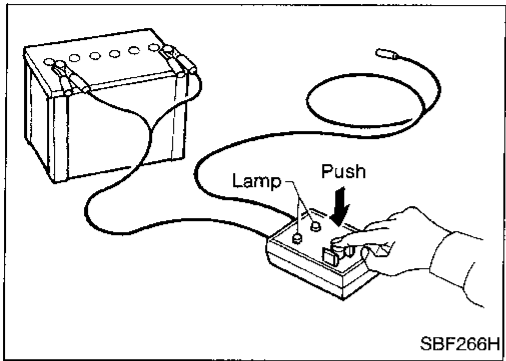

DEPLOYMENT PROCEDURES FOR AIR BAG MODULE (Outside of vehicle)

Deploying air bag module while it is mounted in vehicle may damage vehicle. Deploy air bag module as a unit except when disposing of vehicle.

Anchor air bag module in a vise secured to a firm foundation during deployment.

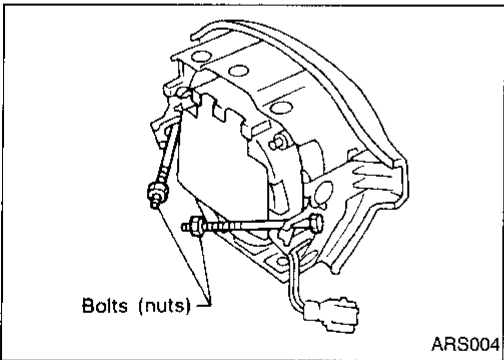

Deployment of driver's air bag module (outside of vehicle)

1. Prepare two sets of nuts and bolts (see figure at left). These bolts are required to secure driver's air bag module to the vise.
2. Install one set of nuts and bolts to each side of air bag module.

CAUTION:

Make sure to install a bolt and nut on each side.

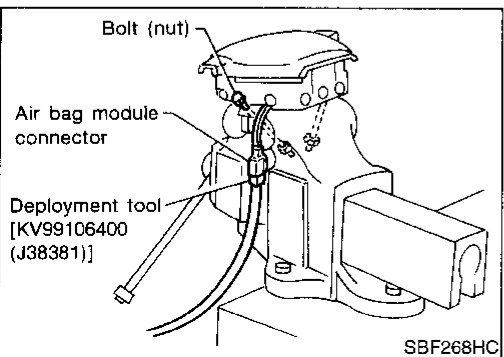

3. Firmly place two nuts (secured to air bag module) in the vise.

CAUTION:

Ensure these two nuts are equally placed in the vise. Never finish the installation with just one nut.

4. Connect deployment tool (SST: J38381) to air bag module connector.

SUPPLEMENTAL RESTRAINT SYSTEM (SRS)

Disposal of Air Bag Module (Cont'd)

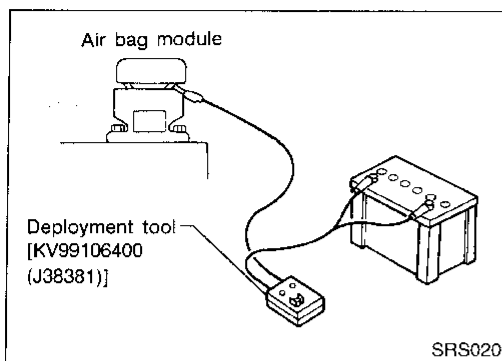

5. Connect red clip of deployment tool to battery positive terminal and black clip to negative terminal.
6. The lamp on the right side of the tool, marked "deployment tool power", should glow green, not red.
7. Press the button on the deployment tool. The left side lamp on the tool, marked "air bag connector voltage", will illuminate and the air bag module will deploy.

CAUTION:

When deploying the air bag module, stand at least 5 m (16 ft) away from the air bag module.

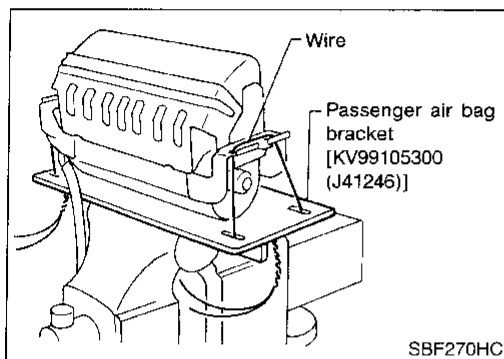

Deployment of passenger air bag module (outside of vehicle)

1. Using wire, secure air bag module to passenger air bag bracket (SST: J41246) at two places.

CAUTION:

Use wire of at least 1 mm (0.04 in) in diameter.

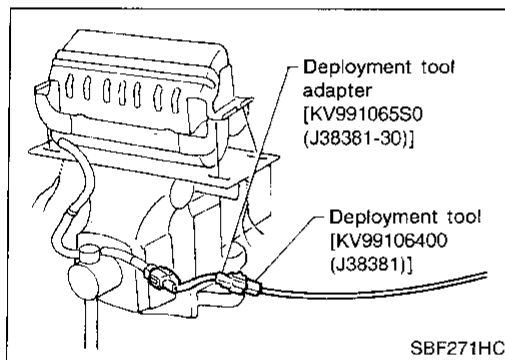

2. Firmly anchor passenger air bag bracket in a vise.
3. Connect deployment tool adapter (SST: J38381-30) to deployment tool (SST: J38381) connector and air bag module connector.

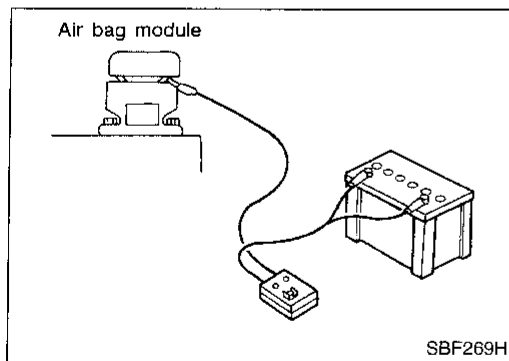

4. Connect red clip of deployment tool to battery positive terminal and black clip to negative terminal.
5. The lamp on the right side of the tool, marked "deployment tool power", should glow green, not red.
6. Press the button on the deployment tool. The left side lamp on the tool, marked "air bag connector voltage", will illuminate and the air bag module will deploy.

CAUTION:

When deploying the air bag module, stand at least 5 m (16 ft) away from the air bag module.

SUPPLEMENTAL RESTRAINT SYSTEM (SRS)

Disposal of Air Bag Module (Cont'd)

DEPLOYMENT OF AIR BAG MODULE WHILE MOUNTED IN VEHICLE

When disposing of vehicles, deploy air bag module while it is mounted in vehicle.

CAUTION:

When deploying air bag module, ensure vehicle is empty.

1. Turn ignition switch "OFF", disconnect both battery cables and wait at least 10 minutes.
2. Disconnect air bag module connector.
3. Connect deployment tool (SST: J38381) connector to air bag module.

For front passenger air bag module, use adapters (SST: J38381-30) to attach module to deployment tool connector.

4. Connect red clip of deployment tool to battery positive terminal and black clip to negative terminal.
5. The lamp on the right side of the tool, marked "deployment tool power", should glow green, not red.
6. Press the button on the deployment tool. The left side lamp on the tool, marked "air bag connector voltage", will illuminate. Then the air bag module will deploy.

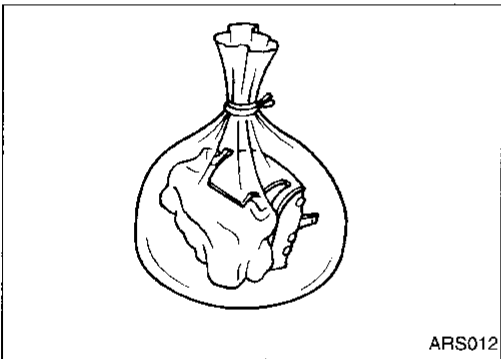
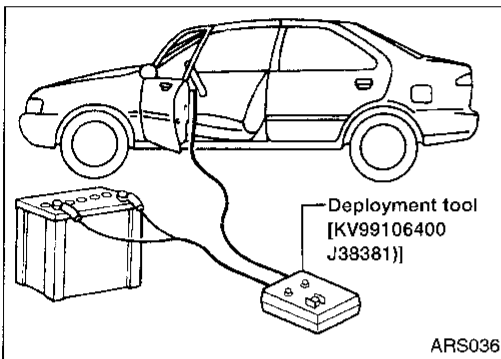
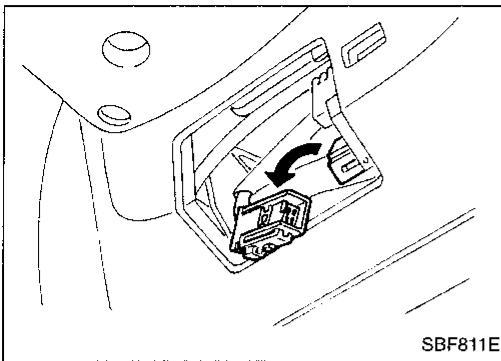

DISPOSING OF AIR BAG MODULE

Deployed air bag module is very hot. Before disposing of air bag module, wait at least 30 minutes. Seal them in a plastic bag before disposal.

CAUTION:

- Never apply water to a deployed air bag module.
- Be sure to wear gloves when handling a deployed air bag module.
- No poisonous gas is produced upon air bag module deployment. However, be careful not to inhale gas since it irritates throat and can cause choking.
- Do not attempt to disassemble air bag module.
- Air bag module cannot be re-used.
- Wash your hands clean after finishing work.

Wiring Diagram -SRS-

RS-SRS-01

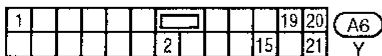
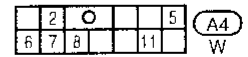
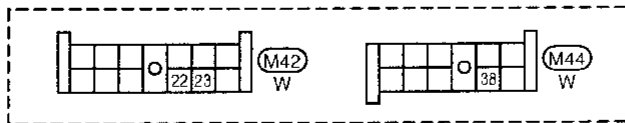
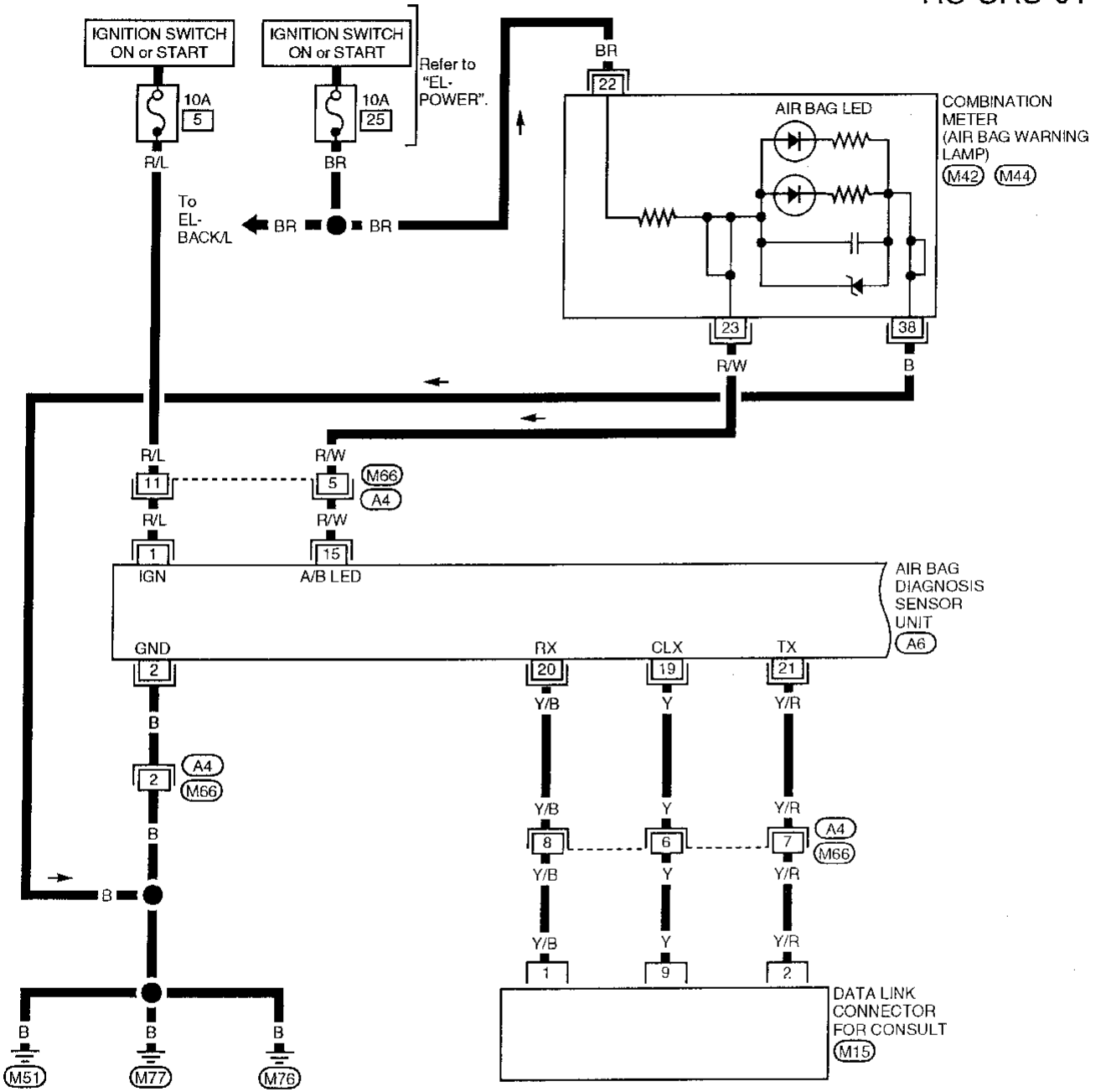

GI
WA
EM
LC
EC
FE
CL
MT
AT
FA
RA
BR
ST
RS
BT
HA
EL
IDX

TROUBLE DIAGNOSES — Supplemental Restraint System (SRS)

Wiring Diagram —SRS— (Cont'd)

RS-SRS-02

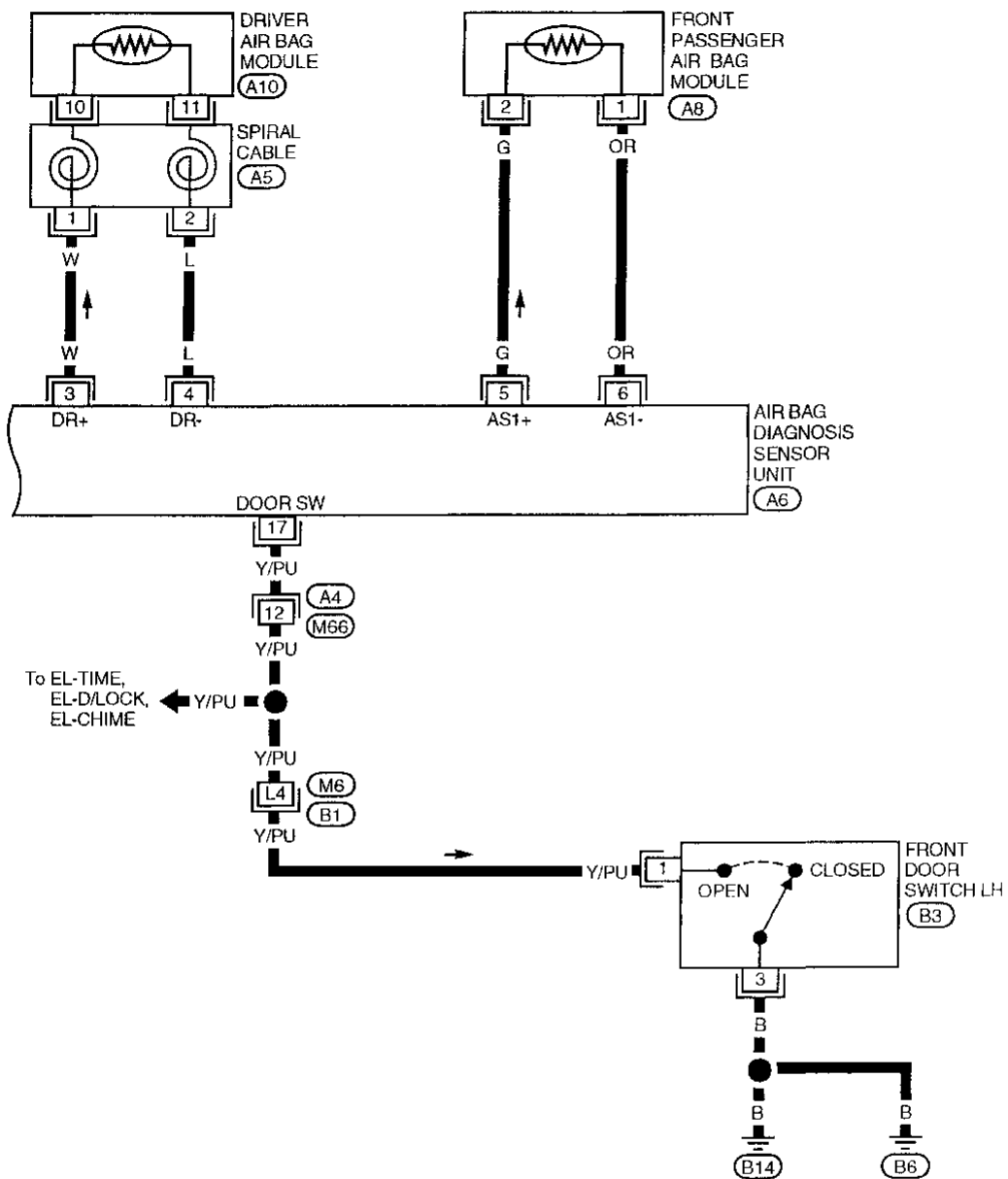

Refer to last page (Foldout page).
 (M6) (B1)

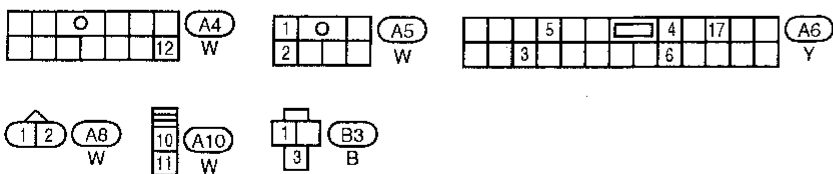

Schematic

CAUTION:

- Do not use a circuit tester to check SRS harness connectors unless instructed to in this Service Manual. SRS wiring harnesses are covered with yellow insulation either just before the harness connectors or for the complete harness, for easy identification.
- Do not attempt to repair, splice or modify the SRS wiring harness. If the harness is damaged, replace it with a new one.
- Keep ground portion clean.

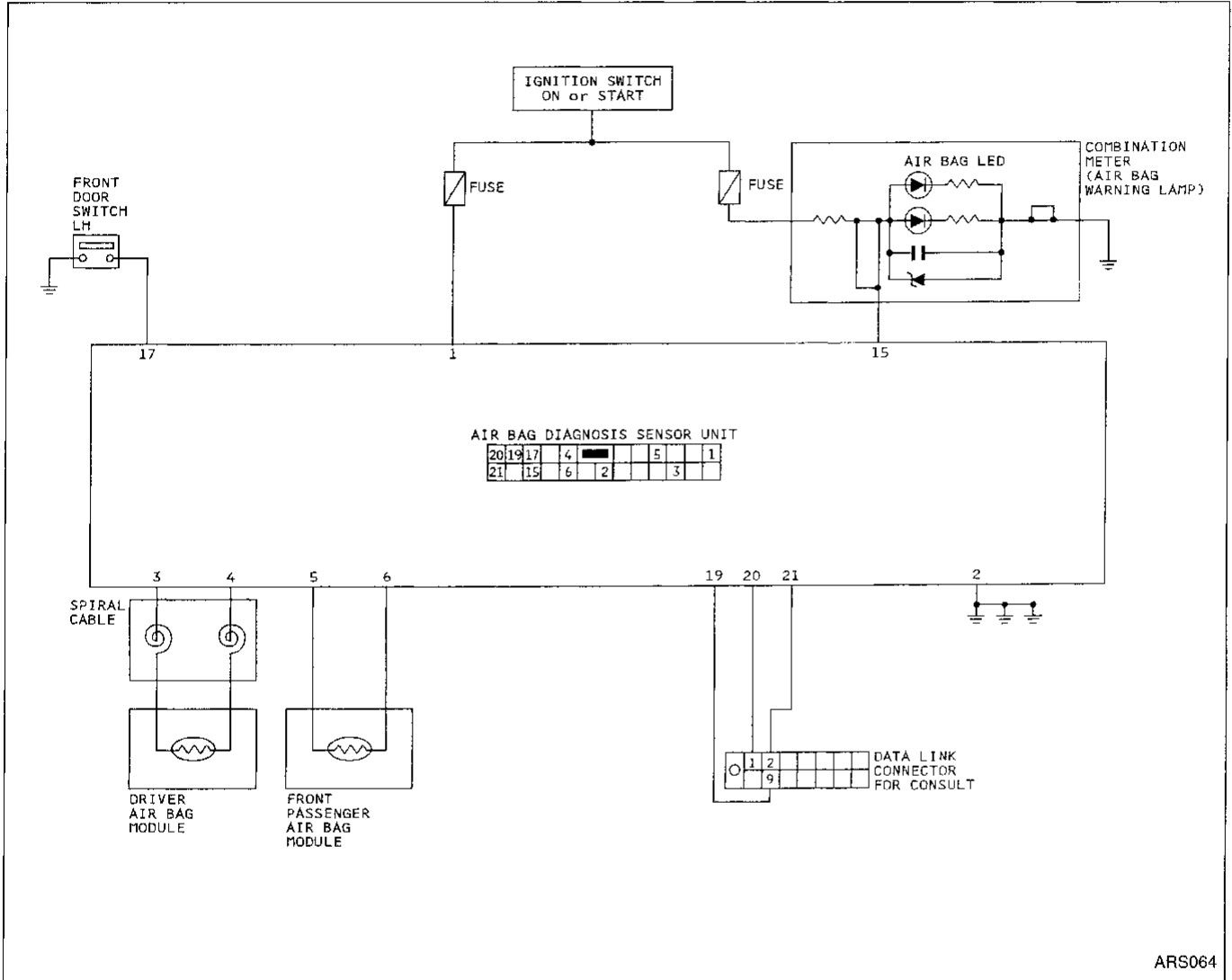

ARS064

GI
 MA
 EM
 LC
 EC
 FE
 CL
 MT
 AT
 FA
 RA
 BR
 ST
RS
 BT
 HA
 EL
 IDX

How to Perform Trouble Diagnoses for Quick and Accurate Repair

A good understanding of the malfunction conditions can make troubleshooting faster and more accurate. In general, each customer feels differently about a problem. It is important to fully understand the symptoms or conditions for a customer complaint.

INFORMATION FROM CUSTOMER

WHAT Vehicle model
WHEN Date, Frequencies
WHERE Road conditions
HOW Operating conditions, Symptoms

PRELIMINARY CHECK

Check that the following parts are in good order.

- Battery [Refer to MA section (“GENERAL MAINTENANCE”).]
- Fuse [Refer to EL section (“Fuse”, “POWER SUPPLY ROUTING”).]
- System component-to-harness connections

DIAGNOSIS FUNCTION

The SRS self-diagnosis results can be read by using “AIR BAG” warning lamp and/or CONSULT. The reading of these results is accomplished using one of two modes — “User mode” and “Diagnosis mode”. The User mode is exclusively prepared for the customer (driver). This mode warns the driver of a system malfunction through the operation of the “AIR BAG” warning lamp.

The Diagnosis mode allows the technician to locate and inspect the malfunctioning part.

The mode applications for the “AIR BAG” warning lamp and CONSULT are as follows:

	User mode	Diagnosis mode	Display type
“AIR BAG” warning lamp	X	X	ON-OFF operation
CONSULT	—	X	Monitoring

DIAGNOSIS MODE FOR CONSULT

- **SELF-DIAG [CURRENT]**
A current Self-diagnosis result (also indicated by the number of warning lamp flashes in the Diagnosis mode) is displayed on the CONSULT screen in real time. This refers to a malfunctioning part requiring repairs.
- **SELF-DIAG [PAST]**
Diagnosis results previously stored in the memory (also indicated by the warning lamp flashes in the User mode) are displayed on the CONSULT screen. The stored results are not erased until memory erasing is executed.
- **TROUBLE DIAG RECORD**
With TROUBLE DIAG RECORD, diagnosis results previously erased by a reset operation can be displayed on the CONSULT screen.

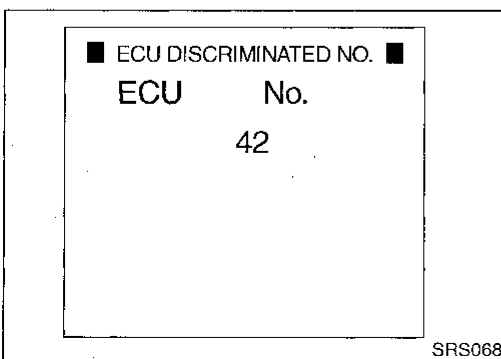

- **ECU DISCRIMINATED NO.**
The diagnosis sensor unit for each vehicle model is assigned with its own, individual classification number. This number will be displayed on the CONSULT screen, as shown at left. When replacing the diagnosis sensor unit, refer to the part number for the compatibility. After installation, replacement with a correct unit can be checked by confirming this classification number on the CONSULT screen.

For model U13, the diagnosis sensor unit classification number assigned is 42.

TROUBLE DIAGNOSES — Supplemental Restraint System (SRS)

How to Perform Trouble Diagnoses for Quick and Accurate Repair (Cont'd)

CAUTION:

- Do not use a circuit tester to check SRS harness connectors unless instructed to in this Service Manual. SRS wiring harnesses are covered with yellow insulation either just before the harness connectors or for the complete harness, for easy identification.
- Do not attempt to repair, splice or modify the SRS wiring harness. If the harness is damaged, replace it with a new one.
- Keep ground portion clean.

WORK FLOW

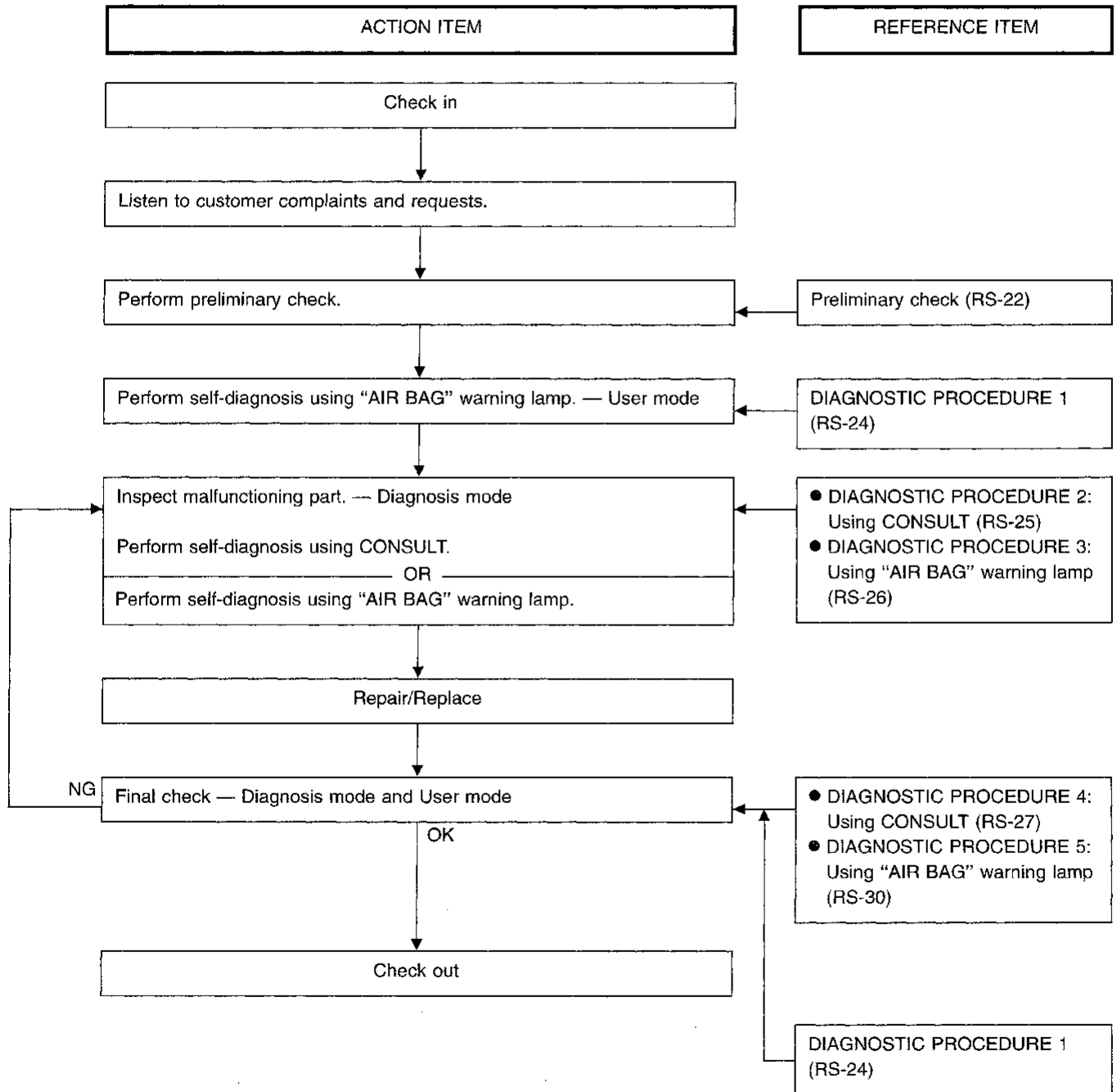

TROUBLE DIAGNOSES — Supplemental Restraint System (SRS)

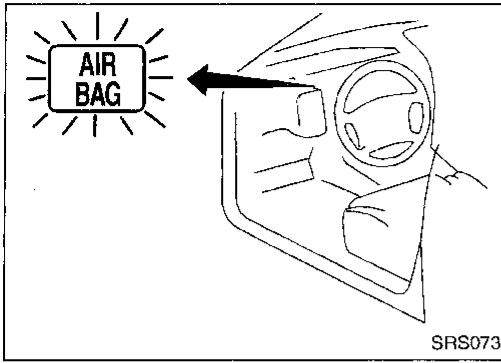

Self-diagnosis

DIAGNOSTIC PROCEDURE 1 (⌚ without CONSULT)

Checking SRS operation by using "AIR BAG" warning lamp — User mode

1. After turning ignition switch from "OFF" to "ON", "AIR BAG" warning lamp operates.
2. Compare "AIR BAG" warning lamp operation to the chart below.

"AIR BAG" warning lamp operation — User mode —	SRS condition	Reference item
<p>MRS095A</p>	No malfunction is detected. No further action is necessary.	—
<p>MRS096A</p>	The system has problem and needs to be repaired as indicated.	Go to DIAGNOSTIC PROCEDURE 2, or 3 (RS-25 or 26).
<p>MRS097A</p>	Air bag is deployed. Fuse for diagnosis sensor unit or circuit is malfunctioning and needs to be repaired.	Go to COLLISION DIAGNOSIS (RS-40). Go to DIAGNOSTIC PROCEDURE 8 (RS-38).
<p>MRS098A</p>	Diagnosis sensor unit or "AIR BAG" warning lamp circuit is shorted or open and needs to be repaired.	Go to DIAGNOSTIC PROCEDURE 9 (RS-38).

NOTE:

If "AIR BAG" warning lamp operates differently from the operations shown above, refer to "AIR BAG" warning lamp operation — Diagnosis mode —, DIAGNOSTIC PROCEDURE 5, RS-30. Then repair as necessary.

TROUBLE DIAGNOSES — Supplemental Restraint System (SRS)

Self-diagnosis (Cont'd)

DIAGNOSTIC PROCEDURE 2 (CONSULT) with CONSULT

Inspecting SRS malfunctioning parts by using CONSULT — Diagnosis mode

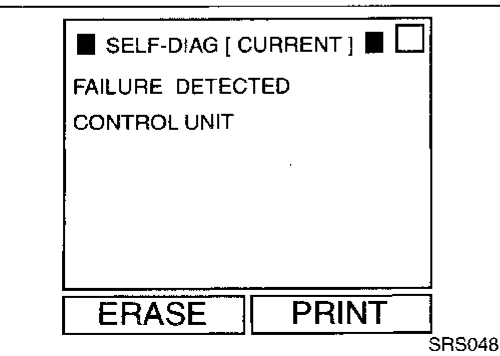
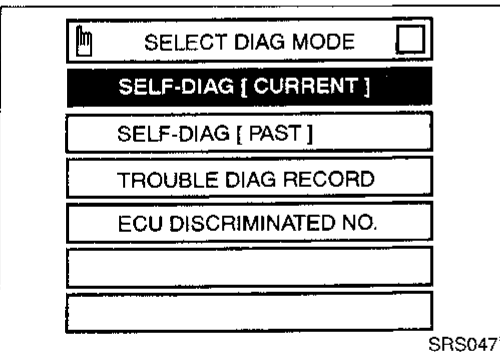
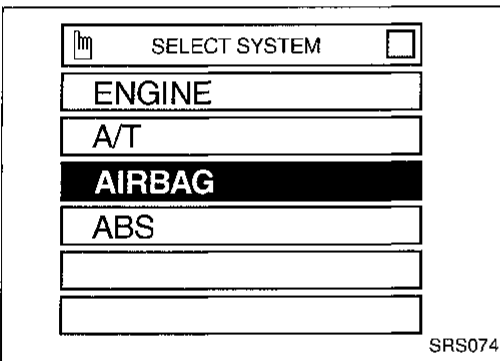
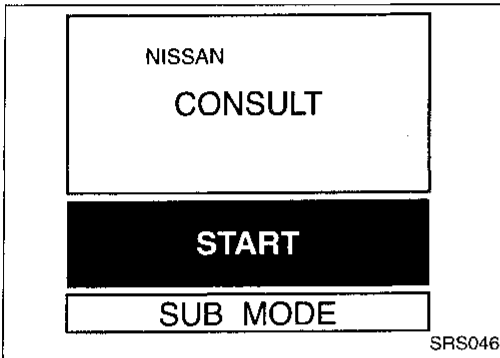
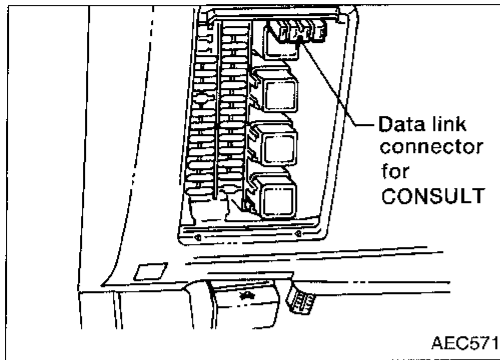

1. Turn ignition switch "OFF".
2. Connect "CONSULT" to Data link connector.

3. Turn ignition switch "ON".
4. Touch "START".

5. Touch "AIRBAG".

6. Touch "SELF-DIAG [CURRENT]".

7. Diagnostic codes are displayed on "SELF-DIAG [CURRENT]".

GE

MA

EM

LC

EC

FE

CL

MT

AT

FA

RA

BR

ST

RS

BT

HA

EL

IDX

TROUBLE DIAGNOSES — Supplemental Restraint System (SRS)

Self-diagnosis (Cont'd)

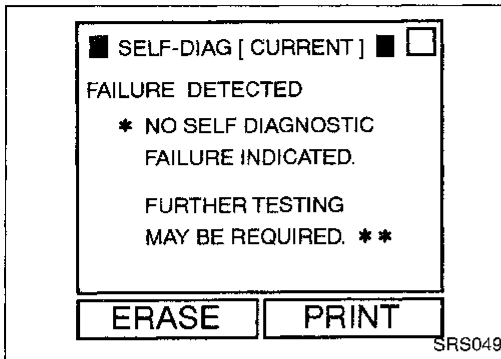

- If no self-diagnostic failure is detected on “SELF-DIAG [CURRENT]” but malfunction is indicated by the “AIR BAG” warning lamp, go to DIAGNOSTIC PROCEDURE 6, page RS-32.

8. Touch “PRINT”.
9. Compare diagnostic codes to the CONSULT DIAGNOSTIC CODE CHART, page RS-35.
10. Touch “BACK” key of CONSULT until SELECT SYSTEM MODE appears, then turn off CONSULT.
11. Turn ignition switch “OFF”, then disconnect CONSULT and both battery cables.
12. Repair the system as outlined by the “Repair order” in CONSULT DIAGNOSTIC CODE CHART, that corresponds to the problem code. For replacement procedure of component parts, refer to RS-10.
13. After repairing the system, go to DIAGNOSTIC PROCEDURE 4, page RS-27.

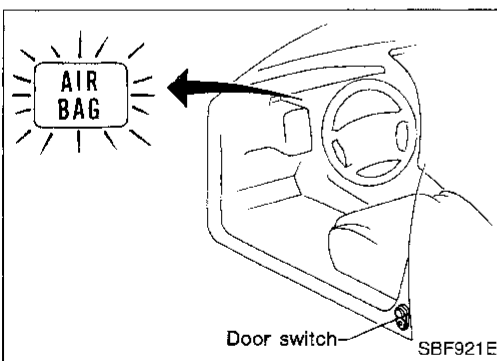

DIAGNOSTIC PROCEDURE 3 (⌚ without CONSULT)

Inspecting SRS malfunctioning parts by using “AIR BAG” warning lamp — Diagnosis mode

NOTE:

SRS will not enter Diagnosis mode if no malfunction is detected in User mode.

1. Open driver's door.
2. Turn ignition switch from “OFF” to “ON”.
3. Press driver's door switch at least 5 times within 7 seconds after turning ignition switch “ON”.
SRS is now in Diagnosis mode.
4. “AIR BAG” warning lamp operates in diagnosis mode as follows:

NOTE:

If SRS does not enter diagnostic mode even though malfunction is detected in User mode, go to DIAGNOSTIC PROCEDURE 10, page RS-39.

TROUBLE DIAGNOSES — Supplemental Restraint System (SRS) Self-diagnosis (Cont'd)

No.	"AIR BAG" warning lamp operation — Diagnosis mode —	SRS condition
1	<p style="text-align: right; margin-right: 50px;">MRS100A</p>	<p>(a) through (b) are repeated.</p> <p>Intermittent problem has been detected in the past. Go to DIAGNOSTIC PROCEDURE 7 (RS-33).</p>
2	<p style="text-align: right; margin-right: 50px;">MRS099A</p>	<p>(a) through (d) are repeated.</p> <p>NOTE: (a) — Interval I (b) — Start signal (Start signal identifies display modes) (c) — Interval II (d) — Indicates malfunctioning part (0.5 sec. ON and 0.5 sec. OFF is counted as one flash.)</p> <p>The system has problem and needs to be repaired.</p>

5. Malfunctioning part is indicated by the number of flashes (part (d)). Compare the number of flashes to WARNING LAMP FLASH CODE CHART, page RS-36, and locate malfunctioning part.
6. Turn ignition switch "OFF", and disconnect both battery cables.
7. Repair the system as outlined by the "Repair order" in WARNING LAMP FLASH CODE CHART that corresponds to the flash code. For replacement procedure of component parts, refer to RS-10.
8. After repairing the system, go to DIAGNOSTIC PROCEDURE 5, page RS-30.

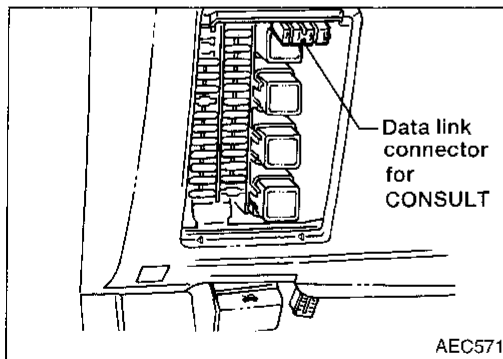

DIAGNOSTIC PROCEDURE 4 (CONSULT with CONSULT) Final checking after repairing SRS by using CONSULT — Diagnosis mode

1. After repairing SRS, connect both battery cables.
2. Connect CONSULT to Data link connector.
3. Turn ignition switch from "OFF" to "ON".
4. Touch "START".

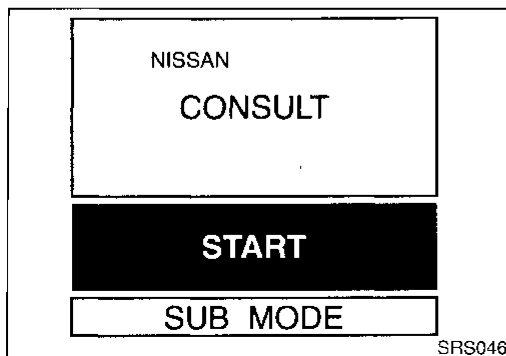

TROUBLE DIAGNOSES — Supplemental Restraint System (SRS)

Self-diagnosis (Cont'd)

SELECT SYSTEM

ENGINE

A/T

AIRBAG

ABS

SRS074

5. Touch "AIRBAG".

SELECT DIAG MODE

SELF-DIAG [CURRENT]

SELF-DIAG [PAST]

TROUBLE DIAG RECORD

ECU DISCRIMINATED NO.

SRS047

6. Touch "SELF-DIAG [CURRENT]".

■ SELF-DIAG [CURRENT] ■

FAILURE DETECTED

* NO SELF DIAGNOSTIC FAILURE INDICATED.

FURTHER TESTING MAY BE REQUIRED. **

ERASE PRINT

SRS049

7. If no malfunction is detected on "SELF-DIAG [CURRENT]", repair of SRS is completed. Touch "ERASE".

NOTE:

Touch "ERASE" to erase problem (Trouble code) retained in memory. Otherwise, CONSULT will still sense problem in memory when step 13 (Air bag warning lamp operation check) is performed. As a result, the "AIR BAG" warning lamp will still indicate a malfunction in the system.

■ SELF-DIAG [CURRENT] ■

FAILURE DETECTED

CONTROL UNIT

ERASE PRINT

SRS048

- If any problem code was displayed on "SELF-DIAG [CURRENT]", the malfunctioning part is not repaired completely or another malfunctioning part is detected. Go to **DIAGNOSTIC PROCEDURE 2**, page RS-25, and repair malfunctioning part completely.

8. Touch "BACK" key of CONSULT.

SELECT DIAG MODE

SELF-DIAG [CURRENT]

SELF-DIAG [PAST]

TROUBLE DIAG RECORD

ECU DISCRIMINATED NO.

SRS050

9. Touch "SELF-DIAG [PAST]".

TROUBLE DIAGNOSES — Supplemental Restraint System (SRS)

Self-diagnosis (Cont'd)

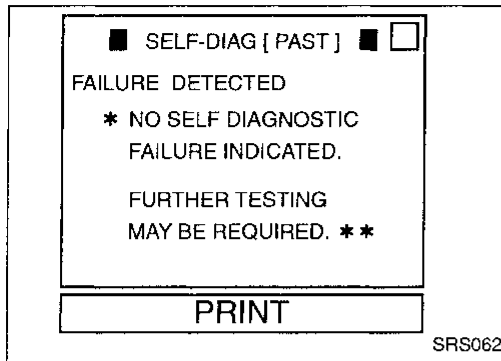

10. Check that no self-diagnostic failure is detected on "SELF-DIAG [PAST]".

11. Touch "BACK" key of CONSULT until SELECT SYSTEM MODE appears, turn off CONSULT, then disconnect CONSULT.
12. Turn ignition switch "OFF".
13. Go to DIAGNOSTIC PROCEDURE 1, page RS-24 to check SRS operation by using "AIR BAG" warning lamp with User mode.

GI

MA

EM

LC

EC

FE

CL

MT

AT

FA

RA

BR

ST

RS

BT

HA

EL

IDX

TROUBLE DIAGNOSES — Supplemental Restraint System (SRS)

Self-diagnosis (Cont'd)

DIAGNOSTIC PROCEDURE 5 (⌚ without CONSULT)

Final checking after repairing SRS by using "AIR BAG" warning lamp — Diagnosis mode and User mode

1. After repairing SRS connect both battery cables.
2. Open driver's door.
3. Turn ignition switch from "OFF" to "ON".
4. "AIR BAG" warning lamp operates in diagnostic mode as follows:

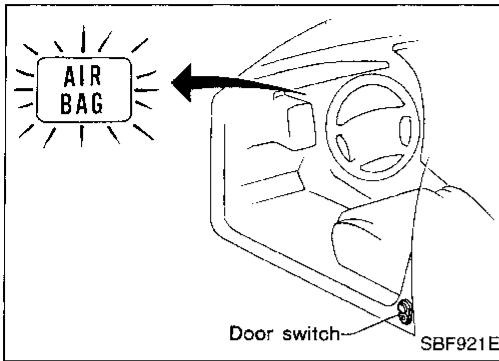

No.	"AIR BAG" warning lamp operation — Diagnosis mode —	SRS condition
1	<p>MRS100A</p>	<p>(a) through (b) are repeated.</p> <p>No malfunction is detected or repair is completed. No further action is necessary.</p>
2	<p>MRS099A</p>	<p>(a) through (d) are repeated.</p> <p>NOTE:</p> <ul style="list-style-type: none"> (a) — Interval I (b) — Start signal (Start signal identifies display modes) (c) — Interval II (d) — Indicates malfunctioning part (0.5 sec. ON and 0.5 sec. OFF is counted as one flash.) <p>The system has problem and needs to be repaired.</p>

5. If "AIR BAG" warning lamp operates as shown in No. 1 in the chart above, turn ignition switch "OFF" to reset from Diagnosis mode to User mode.

If "AIR BAG" warning lamp operates as in No. 2 in chart above, the malfunctioning part is not repaired completely, or another malfunctioning part is detected. Go to DIAGNOSTIC PROCEDURE 3, page RS-26, and repair malfunctioning part completely.

TROUBLE DIAGNOSES — Supplemental Restraint System (SRS)



Self-diagnosis (Cont'd)

6. "AIR BAG" warning lamp operates in User mode. Compare "AIR BAG" warning lamp operation to the chart below.

NOTE:

Turn ignition switch from "OFF" to "ON", and press driver's door switch at least 5 times within 7 seconds after turning ignition switch "ON".

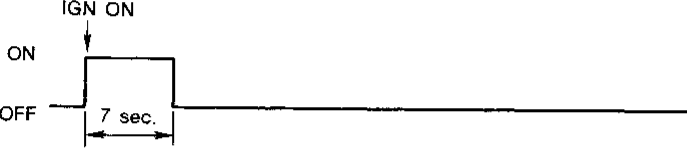
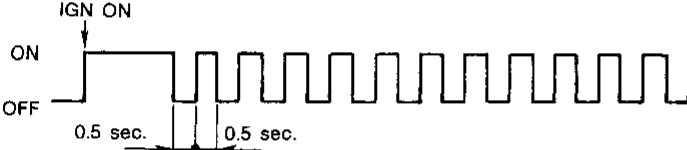
SRS is now in User mode.

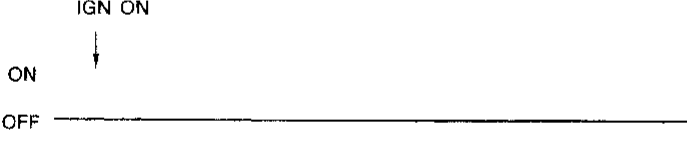
"AIR BAG" warning lamp operation — User mode —	SRS condition	Reference item
 <p>MRS095A</p>	No malfunction is detected. No further action is necessary.	—
 <p>MRS096A</p>	The system has problem and needs to be repaired as indicated.	Go to DIAGNOSTIC PROCEDURE 2 or 3 (RS-25 or 26).
 <p>MRS097A</p>	Air bag is deployed. Fuse for diagnosis sensor unit or circuit is malfunctioning and needs to be repaired.	Go to COLLISION DIAGNOSIS (RS-40). Go to DIAGNOSTIC PROCEDURE 8 (RS-38).
 <p>MRS098A</p>	Diagnosis sensor unit or "AIR BAG" warning lamp circuit is shorted or open and needs to be repaired.	Go to DIAGNOSTIC PROCEDURE 9 (RS-38).

GI
MA
EM
LC
EC
FE
CL
MT
AT
FA
RA
BR
ST
RS
BT
HA
EL
IDX

TROUBLE DIAGNOSES — Supplemental Restraint System (SRS)

Self-diagnosis (Cont'd)

DIAGNOSTIC PROCEDURE 6 (Continued from DIAGNOSTIC PROCEDURE 2)

Inspecting SRS malfunctioning record and checking battery voltage

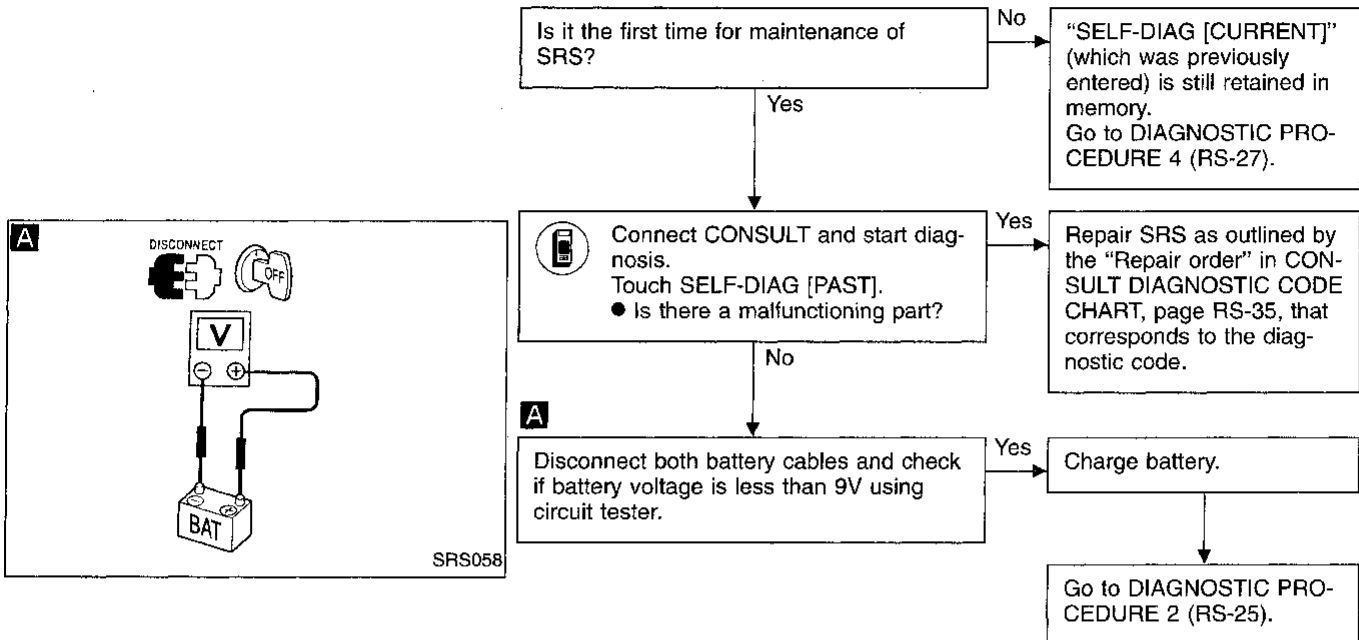

TROUBLE DIAGNOSES — Supplemental Restraint System (SRS)

Self-diagnosis (Cont'd)

DIAGNOSTIC PROCEDURE 7 (CONSULT with CONSULT)

Inspecting SRS intermittent problem by using CONSULT — Diagnosis mode

1. Turn ignition switch "OFF".
2. Connect "CONSULT" to Data link connector.
3. Turn ignition switch "ON".
4. Touch "START".

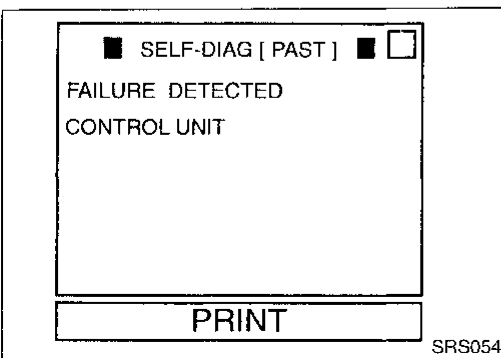
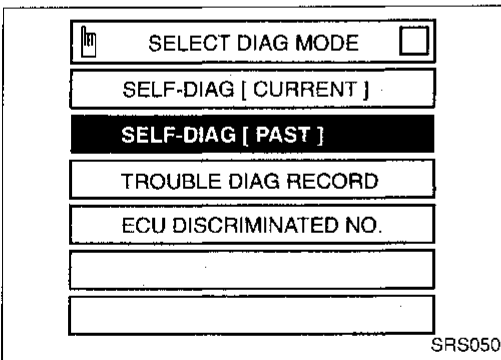
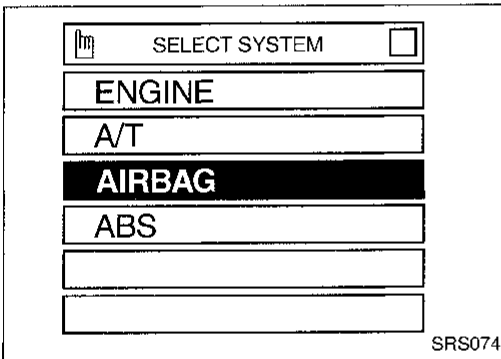
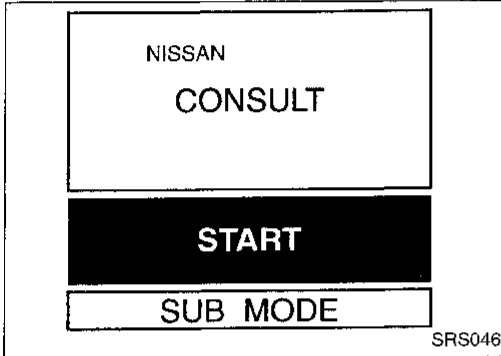
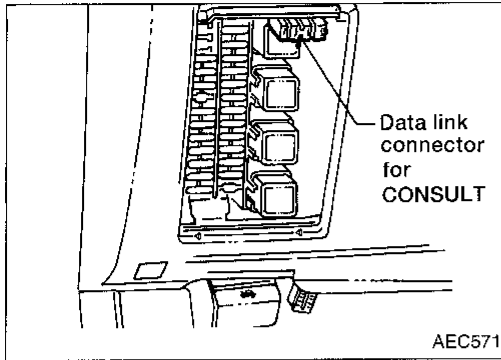

5. Touch "AIRBAG".

6. Touch "SELF-DIAG [PAST]".

7. If diagnostic codes are displayed on "SELF-DIAG [PAST]", go to step 10.

GI
MA
EM
LC
EC
FE
CL
MT
AT
FA
RA
BR
ST
RS
BT
HA
EL
IDX

TROUBLE DIAGNOSES — Supplemental Restraint System (SRS)

Self-diagnosis (Cont'd)

If no self-diagnostic failure is detected on "SELF-DIAG [PAST]", touch "BACK" and go back to "SELECT DIAG MODE".

■ SELF-DIAG [PAST] ■ □

FAILURE DETECTED

* NO SELF DIAGNOSTIC FAILURE INDICATED.

FURTHER TESTING MAY BE REQUIRED. **

PRINT

SRS062

SELECT DIAG MODE □

SELF-DIAG [CURRENT]

SELF-DIAG [PAST]

TROUBLE DIAG RECORD

ECU DISCRIMINATED NO.

SRS055

8. Touch "TROUBLE DIAG RECORD".

■ TROUBLE DIAG RECORD ■ □

FAILURE DETECTED

ASSIST A/B MODULE { OPEN }

PRINT

SRS056

9. Diagnostic code is displayed on "TROUBLE DIAG RECORD".

10. Touch "PRINT".
11. Compare diagnostic codes to the INTERMITTENT PROBLEM DIAGNOSTIC CODE CHART, page RS-37.
12. Touch "BACK" key of CONSULT until SELECT SYSTEM MODE appears, then turn off CONSULT.
13. Turn ignition switch "OFF", then disconnect CONSULT and both battery cables.
14. Repair the system as outlined by the "Repair order" in INTERMITTENT PROBLEM DIAGNOSTIC CODE CHART, that corresponds to the problem code. For replacement procedure of component parts, refer to RS-10.

TROUBLE DIAGNOSES — Supplemental Restraint System (SRS)

Self-diagnosis (Cont'd)

CONSULT DIAGNOSTIC CODE CHART

Diagnostic item	Explanation/Possible causes	Repair order *Recheck SRS using CONSULT at each replacement	
NO SELF DIAGNOSTIC FAILURE INDICATED	<ul style="list-style-type: none"> No malfunction is detected. 	—	CI MA EM LC EC FE CL MT AT FA RA BR
AIRBAG MODULE [OPEN]	<ul style="list-style-type: none"> Driver air bag module circuit is open (including the spiral cable). 	<ol style="list-style-type: none"> 1. Visually check the wiring harness connections. 2. Replace spiral cable. 3. Replace driver's air bag module. (Before disposing of it, it must be deployed.) 4. Replace diagnosis sensor unit. 5. Replace air bag harness. 	
AIRBAG MODULE [VB-SHORT]	<ul style="list-style-type: none"> Driver air bag module circuit is shorted to some power supply circuit (including the spiral cable). 		
AIRBAG MODULE [GND-SHORT]	<ul style="list-style-type: none"> Driver air bag module circuit is shorted to ground (including the spiral cable). 		
AIRBAG MODULE [SHORT]	<ul style="list-style-type: none"> Driver air bag module circuits are shorted to each other. 		
ASSIST A/B MODULE [OPEN]	<ul style="list-style-type: none"> The circuit for front passenger air bag module is open. 	<ol style="list-style-type: none"> 1. Visually check wiring harness connections. 2. Replace front passenger air bag module. (Before disposing of it, it must be deployed.) 3. Replace diagnosis sensor unit. 4. Replace air bag harness. 	
ASSIST A/B MODULE [VB-SHORT]	<ul style="list-style-type: none"> Front passenger air bag module circuit is shorted to some power supply circuit. 		
ASSIST A/B MODULE 1 [GND-SHORT]	<ul style="list-style-type: none"> Front passenger air bag module circuit is shorted to ground. 		
ASSIST A/B MODULE 1 [SHORT]	<ul style="list-style-type: none"> Front passenger air bag module circuits are shorted to each other. 		
CONTROL UNIT	<ul style="list-style-type: none"> Diagnosis sensor unit is out of order. 	<ol style="list-style-type: none"> 1. Visually check wiring harness connections. 2. Replace diagnosis sensor unit. 3. Replace air bag harness. 4. Replace main harness. 	
INDEFINITE FAILURES [AIR BAG]	<ul style="list-style-type: none"> A problem which cannot be specified occurs because more than two parts are out of order. 	<ol style="list-style-type: none"> 1. Visually check wiring harness connections. 2. Replace diagnosis sensor unit. 3. Replace spiral cable and air bag modules. 4. Replace air bag harness. 5. Replace the main harness. 	

*Follow the procedures in numerical order when repairing malfunctioning parts. Confirm whether malfunction is eliminated using the air bag warning lamp (in user mode) or CONSULT each time repair is finished. If malfunction is still observed, proceed to the next step. When malfunction is eliminated, further repair work is not required.

CI
MA
EM
LC
EC
FE
CL
MT
AT
FA
RA
BR
ST
BT
HA
EL
DX

RS

TROUBLE DIAGNOSES — Supplemental Restraint System (SRS)

Self-diagnosis (Cont'd)

WARNING LAMP FLASH CODE CHART

Warning lamp	Flash code  (# of flashes)	Explanation	Repair order *Recheck SRS at each replacement
"AIR BAG" warning lamp	0	<ul style="list-style-type: none"> No malfunction is detected. 	—
	2	<ul style="list-style-type: none"> The driver air bag module circuit is out of order. 	<ol style="list-style-type: none"> Visually check the wiring harness connections. Replace the spiral cable. Replace the driver air bag module. (Before disposing of it, it must be deployed.) Replace the diagnosis sensor unit. Replace the air bag harness.
	7	<ul style="list-style-type: none"> The diagnosis sensor unit is out of order. 	<ol style="list-style-type: none"> Visually check the wiring harness connections. Replace the diagnosis sensor unit. Replace the air bag harness. Replace the main harness.
	8	<ul style="list-style-type: none"> The front passenger air bag module circuit is out of order. 	<ol style="list-style-type: none"> Visually check the wiring harness connections. Replace the front passenger air bag module. (Before disposing of it, it must be deployed.) Replace the diagnosis sensor unit. Replace the air bag harness.
	9	<ul style="list-style-type: none"> More than two parts groups are out of order. 	<ol style="list-style-type: none"> Visually check the wiring harness connections. Replace the diagnosis sensor unit. Replace spiral cable and air bag module. Replace the air bag harness. Replace the main harness.

*Follow the procedures in numerical order when repairing malfunctioning parts. Confirm whether malfunction is eliminated using the air bag warning lamp (in user mode) or CONSULT each time repair is finished. If malfunction is still observed, proceed to the next step. When malfunction is eliminated, further repair work is not required.

TROUBLE DIAGNOSES — Supplemental Restraint System (SRS)

Self-diagnosis (Cont'd)

INTERMITTENT PROBLEM DIAGNOSTIC CODE CHART

Diagnostic item	Explanation	Repair order *Recheck SRS at each replacement.
NO SELF DIAGNOSTIC FAILURE INDICATED.	● No malfunction is detected.	—
AIRBAG MODULE [VB-SHORT]	● Driver's air bag module circuit is shorted to some power supply circuit (including the spiral cable).	1. Visually check the wiring harness connection. 2. Replace the harness if it has visible damage. 3. Replace the spiral cable.
AIRBAG MODULE [OPEN]	● Driver's air bag module circuit is open (including the spiral cable).	1. Visually check the wiring harness connection. 2. Replace the harness if it has visible damage. 3. Replace the spiral cable.
AIRBAG MODULE [GND-SHORT]	● Driver's air bag module circuit is shorted to ground (including the spiral cable).	4. Replace driver's air bag module. (Before disposal of it, it must be deployed.)
AIRBAG MODULE [SHORT]	● Driver's air bag module circuits are shorted to each other.	
ASSIST A/B MODULE [VB-SHORT]	● Front passenger air bag module circuit is shorted to some power supply circuit.	1. Visually check the wiring harness connection. 2. Replace the harness if it has visible damage. 3. Replace the air bag harness.
ASSIST A/B MODULE [OPEN]	● Front passenger air bag module circuit is open.	1. Visually check the wiring harness connection. 2. Replace the harness if it has visible damage. 3. Replace front passenger air bag module. (Before disposal of it, it must be deployed.)
ASSIST A/B MODULE [GND-SHORT]	● Front passenger air bag module circuit is shorted to ground.	
ASSIST A/B MODULE [SHORT]	● Front passenger air bag module circuits are shorted to each other.	
CONTROL UNIT	● Diagnosis sensor unit is out of order.	● Replace the diagnosis sensor unit.

*Follow the procedures in numerical order when repairing malfunctioning parts. Confirm whether malfunction is eliminated using the air bag warning lamp (in user mode) or CONSULT each time repair is finished. If malfunction is still observed, proceed to the next step. When malfunction is eliminated, further repair work is not required.

CI
 MA
 EM
 LC
 EC
 FE
 CL
 MT
 AT
 FA
 RA
 BR
 ST
 RS
 BT
 HA
 EL
 IDX

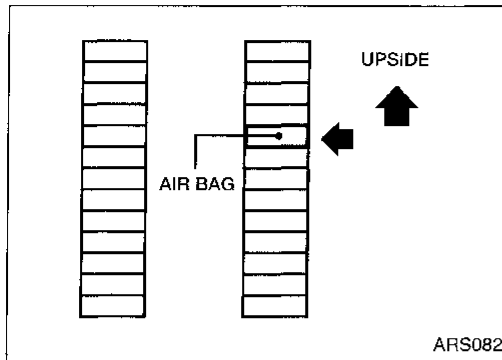

Trouble Diagnoses for Air Bag Warning Lamp DIAGNOSTIC PROCEDURE 8

SYMPTOM: "AIR BAG" warning lamp does not turn off.

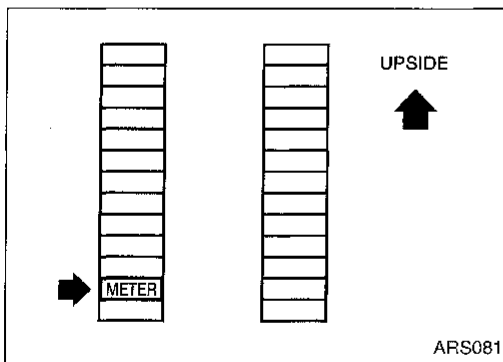
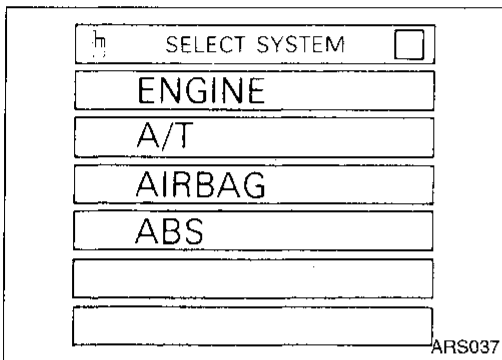
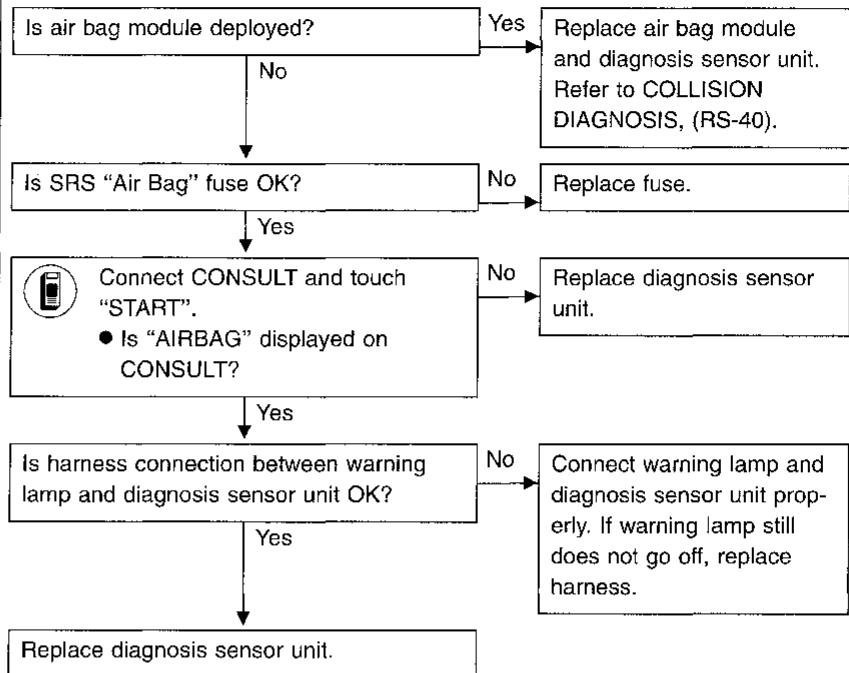

DIAGNOSTIC PROCEDURE 9

SYMPTOM: "AIR BAG" warning lamp does not turn on.

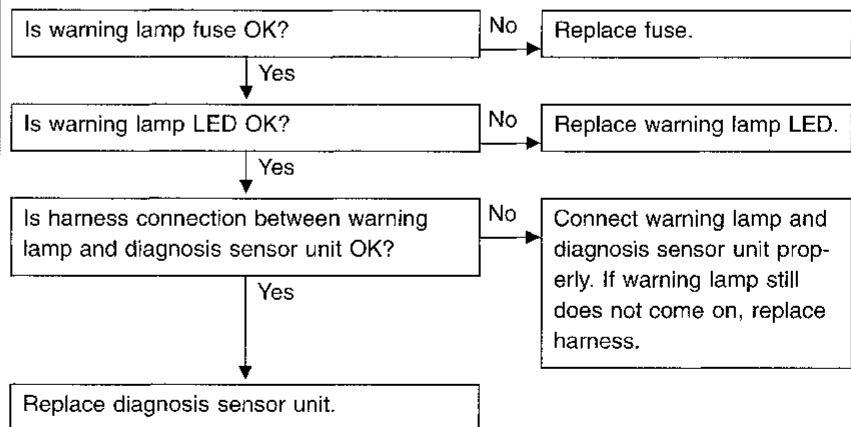

TROUBLE DIAGNOSES — Supplemental Restraint System (SRS)

Trouble Diagnoses for Air Bag Warning Lamp (Cont'd)

DIAGNOSTIC PROCEDURE 10

SYMPTOM: SRS does not enter Diagnostic mode.

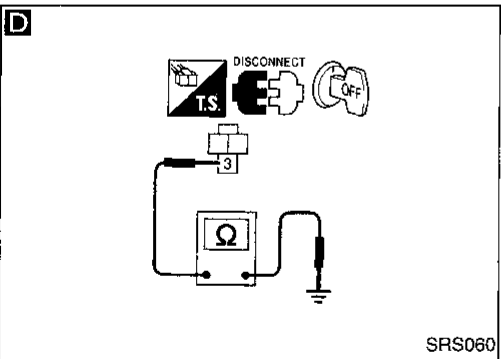
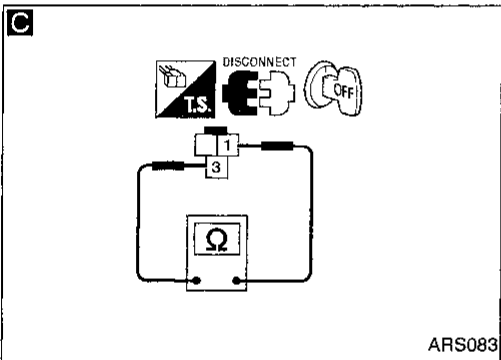
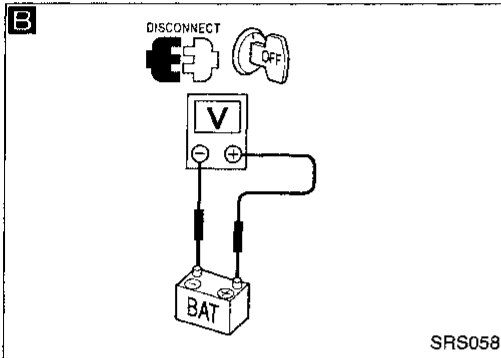
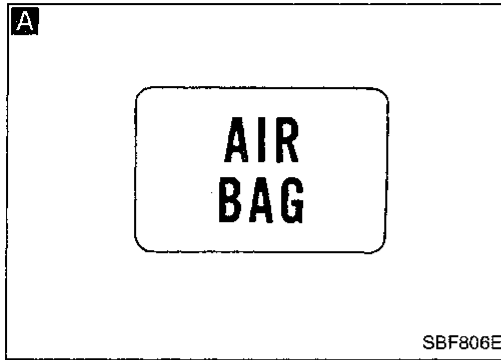

A

Is "AIR BAG" warning lamp blinking?

No → SRS is in good order. Setting the CONSULT to the Diagnosis mode is impossible. No further action is necessary.

Yes →

B

Disconnect both battery cables and check battery voltage using circuit tester.

- Is battery voltage more than 9V?

No → Charge battery.

Yes →

C

Remove driver's door switch and check continuity between driver's door switch connector terminals ① and ③ under the following conditions.

Condition	Continuity
Door switch is depressed (Door is closed).	NO
Door switch is released (Door is open).	YES

No → Replace driver's door switch.

Yes →

D

Check harness continuity between driver's door switch connector terminal ③ and body ground.

- Does continuity exist?

No → Replace or repair harness.

Yes →

Replace diagnosis sensor unit.

Go to DIAGNOSTIC PROCEDURE 3.

CI
MA
EM
LC
EC
FE
CL
MT
AT
FA
RA
BR
ST
RS
BT
HA
EL
IDX

COLLISION DIAGNOSIS

To repair the SRS, perform the following steps.

When SRS is activated in a collision:

- ① Replace the diagnosis sensor unit.
- ② Remove the air bag modules.
- ③ Check the SRS components using the table shown below:
 - Replace any SRS components showing visible signs of damage (dents, cracks, deformation).
- ④ Conduct self-diagnosis. Refer to "Self-diagnosis" for details (RS-24). Ensure the remainder of the SRS is operating properly.
- ⑤ Install new air bag modules.
- ⑥ Conduct self-diagnosis again.

When SRS is not activated in a collision:

- ① Check the SRS components using the table shown below:
 - Replace any SRS components showing visible signs of damage (dents, cracks, deformation).
- ② Conduct self-diagnosis using CONSULT and "AIR BAG" warning lamp. Refer to "Self-diagnosis" for details (RS-24). Ensure entire SRS operates properly.

SRS inspection

Part	SRS is activated	SRS is NOT activated
Air bag module (driver and passenger side)	REPLACE Install with new bolts.	1. Remove air bag module. Check harness cover and connectors for damage, terminals for deformities, and harness for binding. 2-1. Install driver air bag module into the steering wheel to check fit and alignment with the wheel. 2-2. Install passenger air bag module into the instrument panel to check fit with the instrument panel. 3. No damage found, reinstall with new bolts. 4. If damaged—REPLACE. Air bag must be deployed before discarding.
Instrument panel	REPLACE Install with new bolts.	1. Check instrument panel for bending, deformities, or cracks. 2. If no damage is found, reinstall with new bolts. 3. If damaged—REPLACE.
Diagnosis sensor unit	REPLACE Install with new bolts.	1. Check case and bracket for dents, cracks or deformities. 2. Check connectors for damage, and terminals for deformities. 3. If no damage is found, reinstall with new bolts. 4. If damaged—REPLACE.
Steering wheel	1. Visually check steering wheel for deformities. 2. Check harness (built into steering wheel) and connectors for damage, and terminals for deformities. 3. Install air bag module to check fit or alignment with steering wheel. 4. Check steering wheel for excessive free play. 5. If no damage is found, reinstall with new bolts. 6. If damaged—REPLACE.	
Spiral cable	1. Visually check spiral cable and combination switch for damage. 2. Check connectors, flat cable and protective tape for damage. 3. Check steering wheel for noise, binding or heavy operation. 4. If no damage is found, reinstall with new bolts. 5. If damaged—REPLACE.	
Harness and Connectors	1. Check connectors for poor connection, damage, and terminals for deformities. 2. Check harness for binding, chafing, cuts, or deformities. 3. If no damage is found, reinstall. 4. Damaged—REPLACE damaged section of harness. Do not attempt to repair, splice or modify any SRS harness.	