

# REAR AXLE AND REAR SUSPENSION

## SECTION **RA**

### CONTENTS

<b>PRECAUTIONS AND PREPARATION</b> .....	2	Inspection.....	11
Precautions .....	2	Strut Assembly.....	11
Special Service Tools.....	2	Upper Rubber Seat And Bushing.....	12
Commercial Service Tools .....	2	Strut Mounting Insulator .....	12
<b>REAR AXLE AND REAR SUSPENSION</b> .....	3	Coil Spring .....	12
<b>ON-VEHICLE SERVICE</b> .....	4	Assembly.....	12
Rear Axle and Rear Suspension Parts.....	4	<b>REAR SUSPENSION — Parallel Link, Radius</b>	
Rear Wheel Bearing .....	4	<b>Link and Stabilizer Bar</b> .....	13
Rear Wheel Alignment.....	5	Removal and Installation .....	13
Preliminary Inspection .....	5	Parallel Link And Radius Link .....	13
Camber .....	5	Stabilizer Bar .....	13
Toe-In.....	5	<b>SERVICE DATA AND SPECIFICATIONS (SDS)</b> .....	14
<b>REAR AXLE — Wheel Hub</b> .....	7	General Specifications .....	14
Removal .....	7	Coil Spring .....	14
Installation .....	8	Stabilizer Bar .....	14
<b>REAR SUSPENSION</b> .....	9	Strut .....	14
Removal and Installation .....	10	Inspection and Adjustment.....	14
<b>REAR SUSPENSION — Coil Spring and Strut</b>		Wheel Alignment (Unladen*) .....	14
<b>Assembly</b> .....	11	Wheel Bearing.....	14
Disassembly.....	11		

GI

MA

EM

LC

EC

FE

CL

MT

AT

FA

**RA**

BR

ST

RS

BT

HA

EL

IDX

## PRECAUTIONS AND PREPARATION

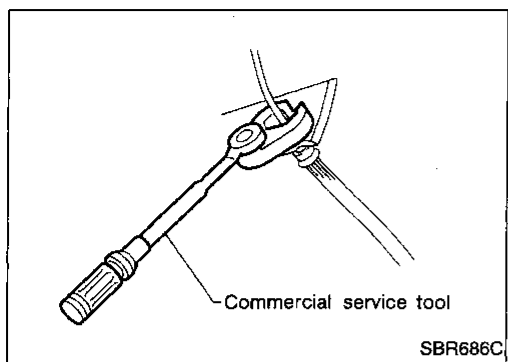

### Precautions

- When installing rubber parts, final tightening must be carried out under unladen condition\* with tires on ground.
- \*: Fuel, radiator coolant and engine oil full. Spare tire, jack, hand tools and mats in designated positions.
- When removing each suspension part, check wheel alignment and adjust if necessary.
- Do not jack up at the parallel links.
- Use flare nut wrench when removing or installing brake tubes.
- Always torque brake lines when installing.

### Special Service Tools

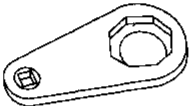
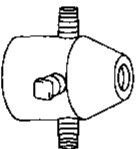
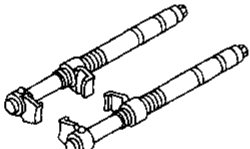
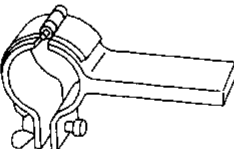
Tool number (Kent-Moore No.) Tool name	Description	
ST35490000 (J26083) Gland packing wrench		Removing and installing gland packing
KV401021S0 ( — ) Bearing race drift		Installing wheel bearing outer race
HT71780000 ( — ) Spring compressor		Removing and installing coil spring
ST35652000 ( — ) Strut attachment		Fixing strut assembly

### Commercial Service Tools

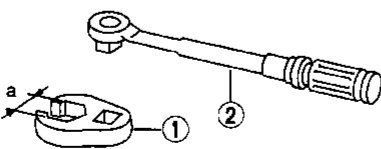
Tool name	Description	
① Flare nut crows foot Distance across flats: 10 mm (0.39 in)		Removing and installing each brake piping
② Torque wrench		a: 10 mm (0.39 in)

# REAR AXLE AND REAR SUSPENSION

When installing rubber parts, final tightening must be carried out under unladen condition\* with tires on ground.

\* Fuel, radiator coolant and engine oil full.  
Spare tire, jack, hand tools and mats in designated positions.

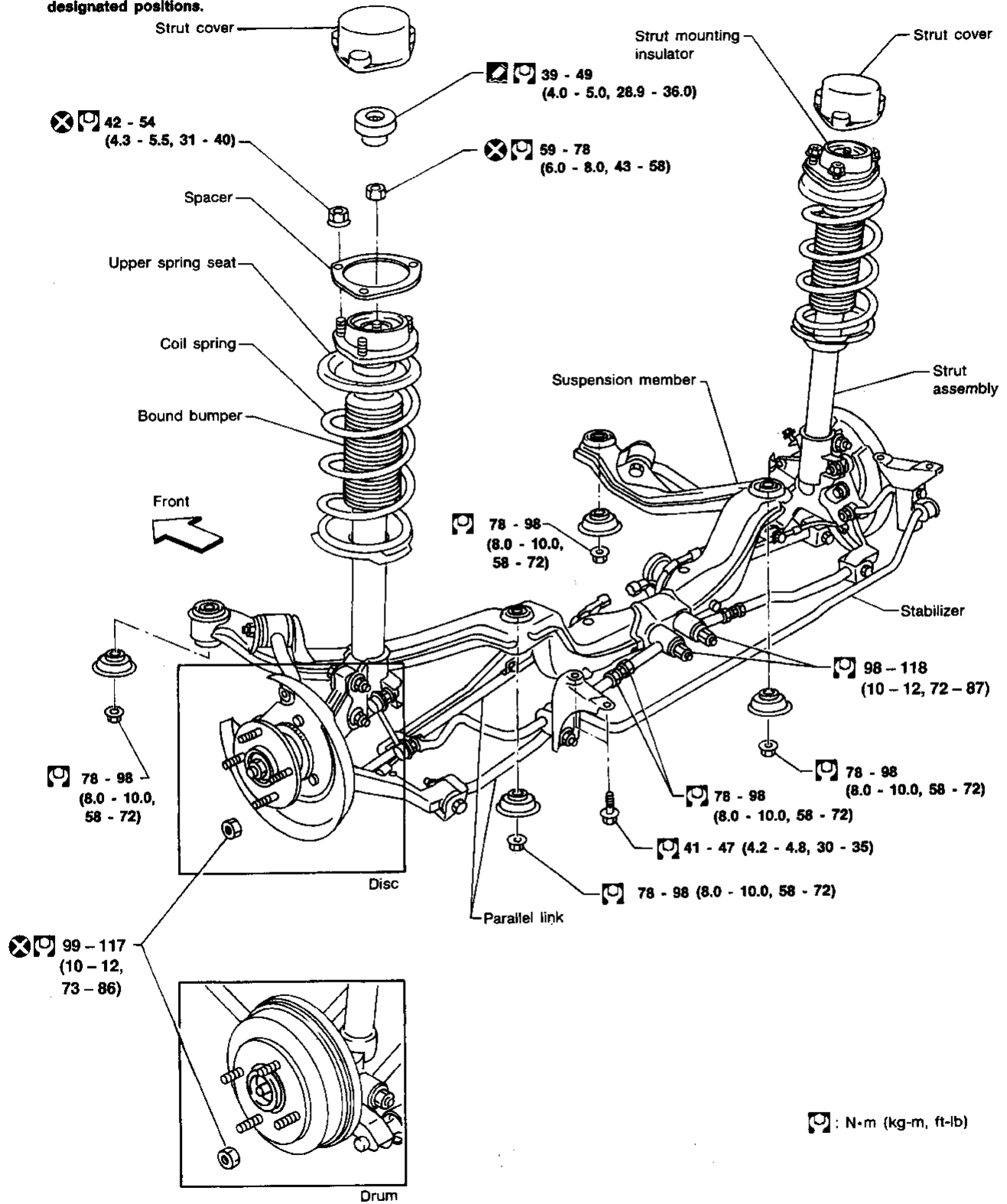

GI  
MA  
EM  
LC  
EC  
FE  
CL  
MT  
AT  
FA  
**RA**  
BR  
ST  
RS  
BT  
HA  
EL  
IDX

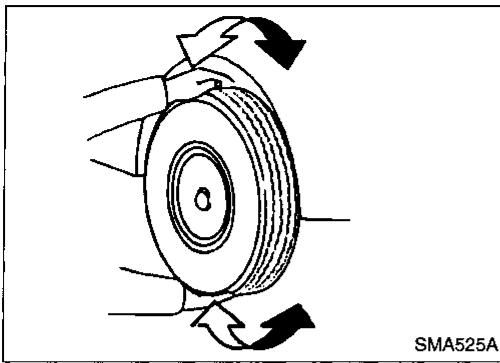

## Rear Axle and Rear Suspension Parts

Check axle and suspension parts for looseness, wear or damage.

- Shake each rear wheel to check excessive play.
- Retighten all nuts and bolts to the specified torque.  
**Tightening torque: Refer to RA-9.**

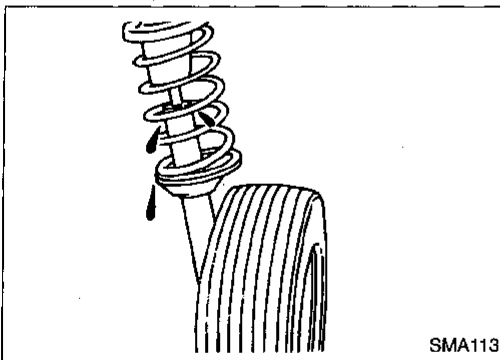
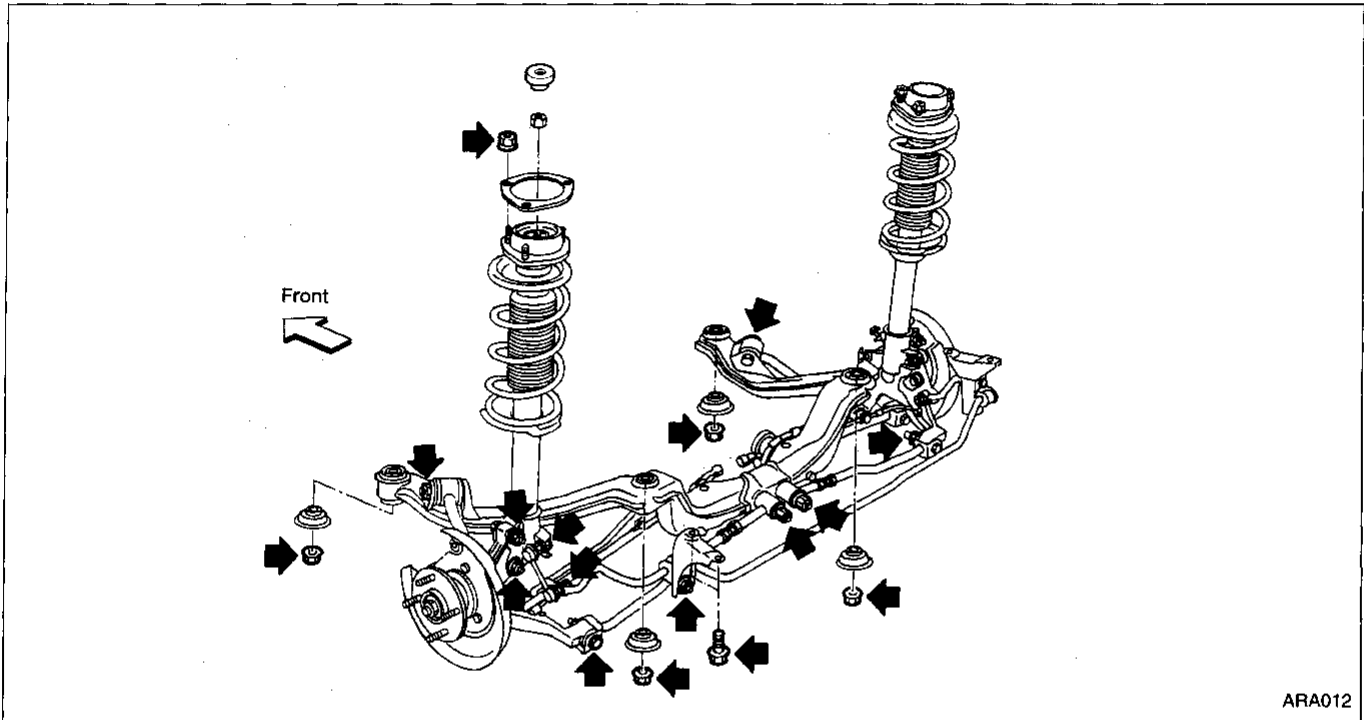

- Check strut (shock absorber) for oil leakage or other damage.
- Check wheelarch height. Refer to FA section ("Front Axle and Front Suspension Parts", "ON-VEHICLE SERVICE").

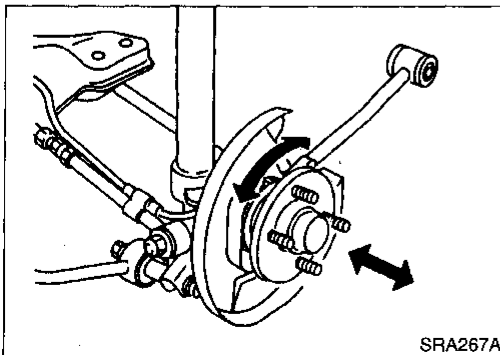

## Rear Wheel Bearing

- Check axial end play.  
**Axial end play:**  
**0.05 mm (0.0020 in) or less**
- Check that wheel bearings operate smoothly.
- Check tightening torque of wheel bearing lock nut.  
**☞: 186 - 255 N·m**  
**(19 - 26 kg-m, 137 - 188 ft-lb)**
- If axial end play is not within specification or wheel bearing does not turn smoothly, replace wheel bearing assembly. Refer to RA-7.

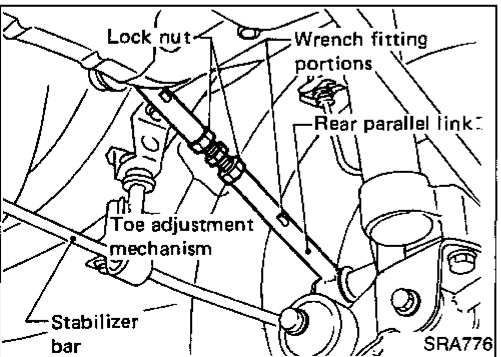
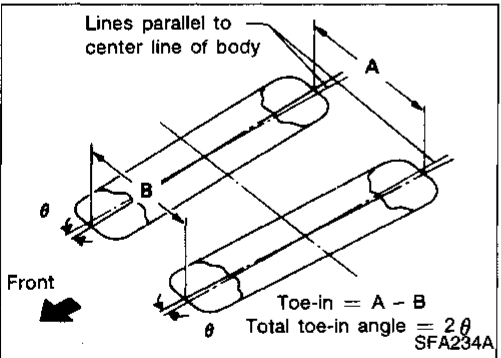
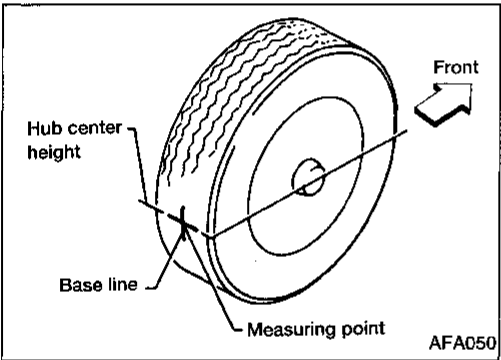
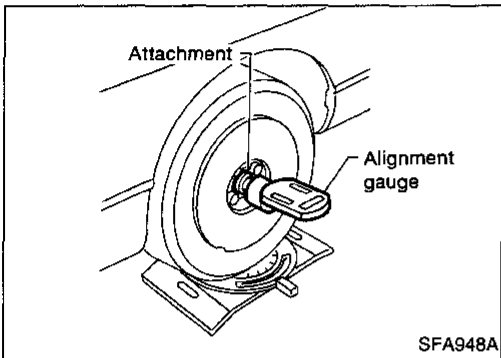
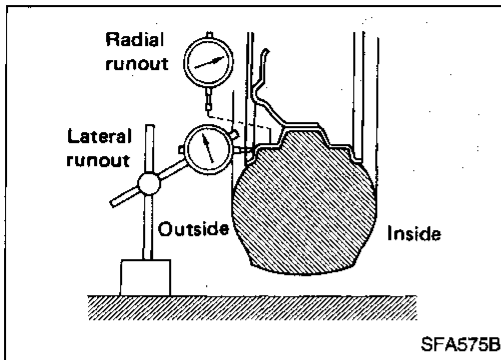

## Rear Wheel Alignment

### PRELIMINARY INSPECTION

Make following checks. Adjust, repair or replace if necessary.

- Check tires for wear and for improper inflation.
- Check rear wheel bearings for looseness.
- Check wheel runout.

**Wheel runout: Refer to FA section ("Inspection and Adjustment", "SDS").**

- Check that rear strut (shock absorber) works properly.
- Check rear axle and rear suspension parts for looseness.
- Check vehicle posture (Unladen\*).

\*: Fuel, radiator and engine oil full. Spare tire, jack, hand tools and mats in designated positions.

### CAMBER

**Camber is preset at factory and cannot be adjusted.**

**Camber:**

**Refer to SDS, RA-14.**

- If the camber is not within specification, inspect and replace any damaged or worn rear suspension parts.

### TOE-IN

**Measure toe-in using following procedure.**

#### WARNING:

- **Always perform following procedure on a flat surface.**
  - **Make sure that no person is in front of the vehicle before pushing it.**
1. Move rear of vehicle up and down to stabilize the posture.
  2. Push the vehicle straight ahead about 5m (196.9 in).
  3. Put a mark on base line of the tread (rear side) at the same height of hub center to be a measuring point.
  4. Measure distance "A" (rear side).
  5. Push the vehicle slowly ahead to turn the wheels around 180 degrees.

**If the wheels have turned 180 degrees, try the above procedure again from the beginning. Never push vehicle backward.**

6. Measure distance "B" (front side).

**Toe-in (A - B):**

**Refer to SDS (RA-14).**

7. Adjust toe-in by varying the lengths of rear parallel links.

GI  
MA  
EM  
LC  
EC  
FE  
CL  
MT  
AT  
FA  
RA  
BR  
ST  
RS  
BT  
HA  
EL  
IDX

## ON-VEHICLE SERVICE

### Rear Wheel Alignment (Cont'd)

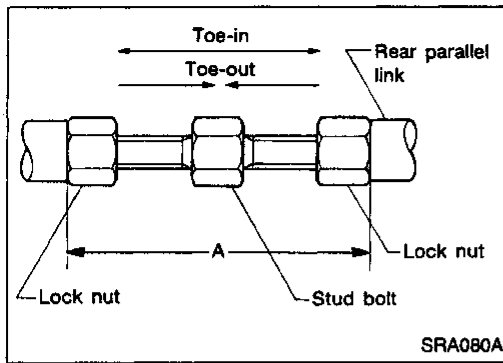

- Adjust left and right rear parallel links to the same length "A".
- Tighten lock nut while holding rear parallel link with wrench to prevent bushing from twisting.

**Standard length "A":**

**50 - 55 mm (1.97 - 2.17 in)**

# REAR AXLE — Wheel Hub

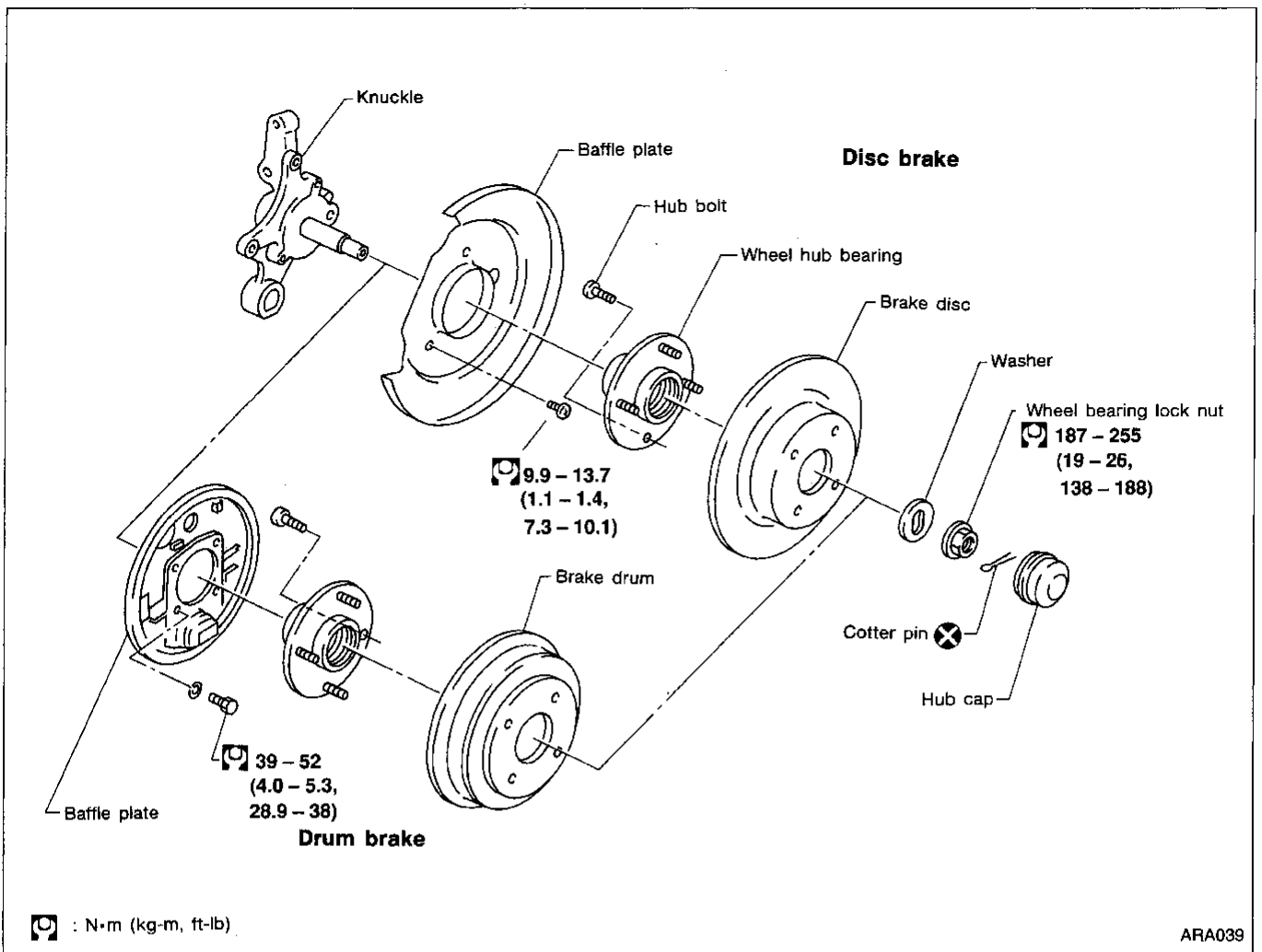

GI  
MA  
EM  
LC  
EC  
FE  
CL  
MT  
AT  
FA

RA

BR

ST

RS

BT

HA

EL

IDX

## Removal

### CAUTION:

- Before removing the rear wheel hub assembly, disconnect the ABS wheel sensor from the assembly. Then move it away from the hub assembly. Failure to do so may result in damaged sensor wires and the sensor becoming inoperative.
- Wheel hub bearing usually does not require maintenance. If any of the following occurs, replace wheel hub bearing assembly.
  - (1) Growling noise is emitted from wheel hub bearing during operation.
  - (2) Wheel hub bearing drags or turns roughly. This occurs when turning hub by hand after bearing lock nut is tightened to specified torque.
  - (3) Wheel hub bearing is removed from knuckle spindle.

## REAR AXLE — Wheel Hub

### Removal (Cont'd)

1. Remove brake caliper assembly.
2. Remove wheel bearing lock nut.

**Brake hose does not need to be disconnected from brake caliper.**

**Be careful not to depress brake pedal, or piston will pop out.**

**Make sure brake hose is not twisted.**

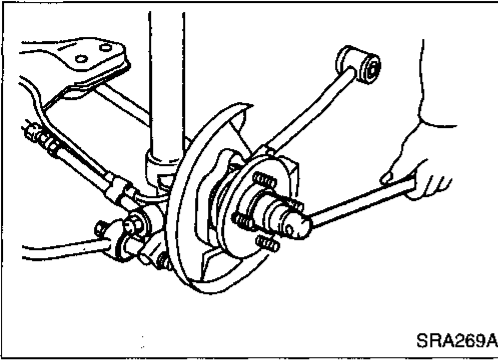

### Installation

1. Install wheel hub bearing.
2. Tighten wheel bearing lock nut.  
Before tightening, apply oil to threaded portion of rear spindle and both sides of plain washer.  
⚠: 186 - 255 N·m  
(19 - 26 kg-m, 137 - 188 ft-lb)
3. Check that wheel bearings operate smoothly.

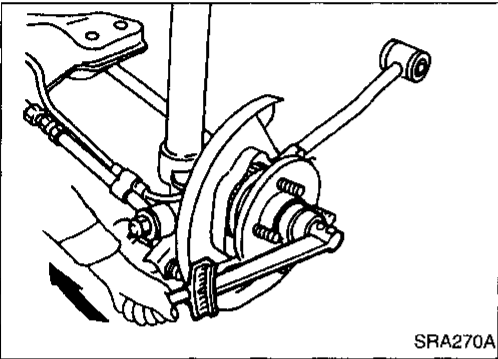

4. Check wheel bearing axial end play.  
**Axial end play:**  
**0.05 mm (0.0020 in) or less**

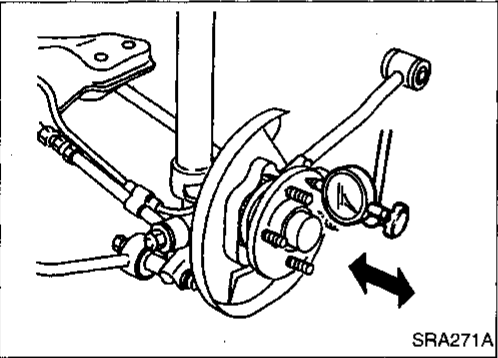



# REAR SUSPENSION

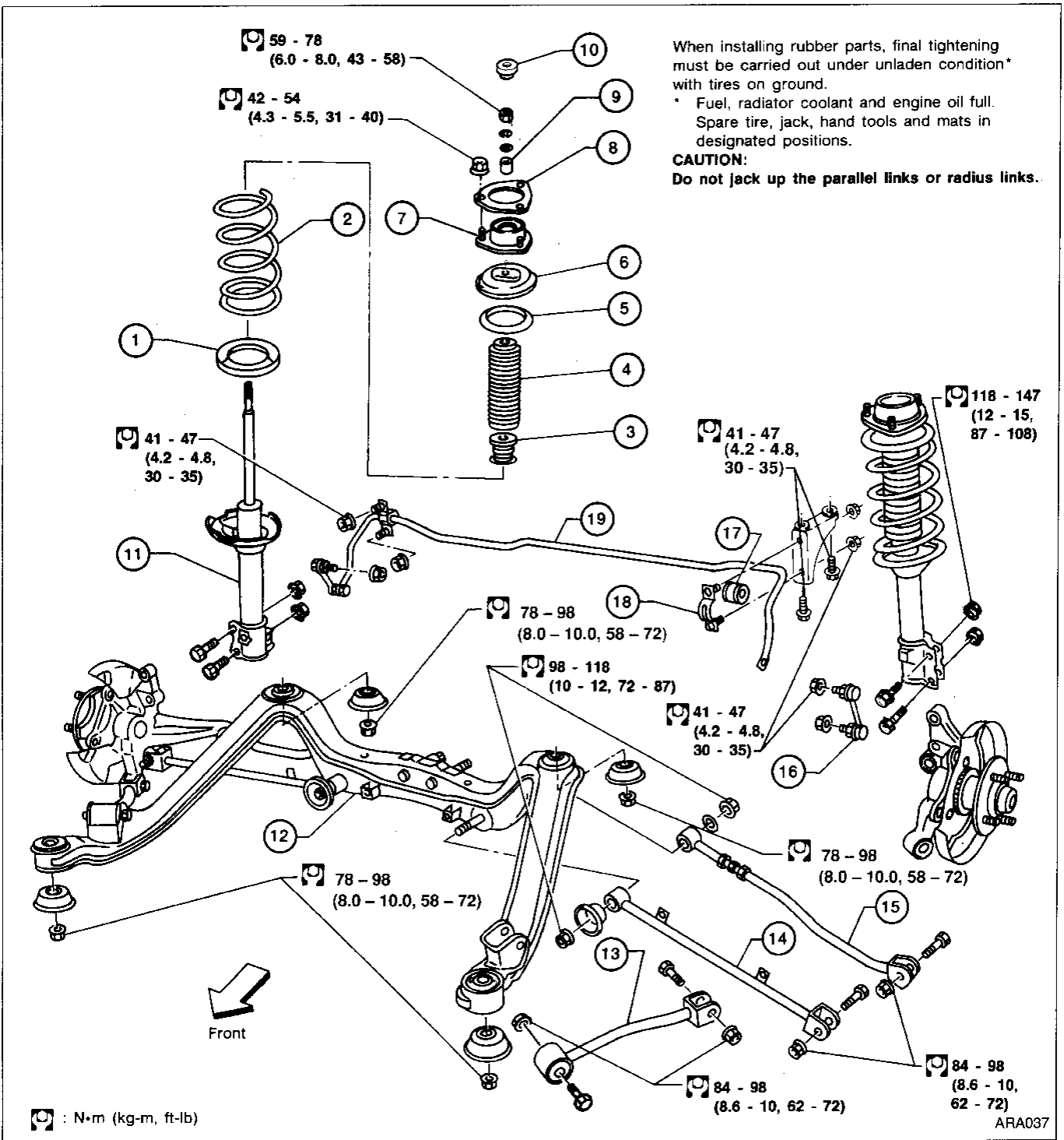

- ① Lower spring rubber seat
- ② Coil spring
- ③ Bound bumper
- ④ Dust cover
- ⑤ Upper spring rubber seat
- ⑥ Upper spring seat

- ⑦ Strut mounting insulator
- ⑧ Spacer
- ⑨ Strut mounting collar
- ⑩ Strut damper
- ⑪ Strut assembly
- ⑫ Suspension member

- ⑬ Radius link
- ⑭ Front parallel link
- ⑮ Rear parallel link
- ⑯ Connecting rod
- ⑰ Bushing
- ⑱ Clamp
- ⑲ Stabilizer bar

GI  
 MA  
 EM  
 LC  
 EC  
 FE  
 CL  
 MT  
 AT  
 FA  
**RA**  
 BR  
 ST  
 RS  
 BT  
 HA  
 EL  
 IDX

## REAR SUSPENSION

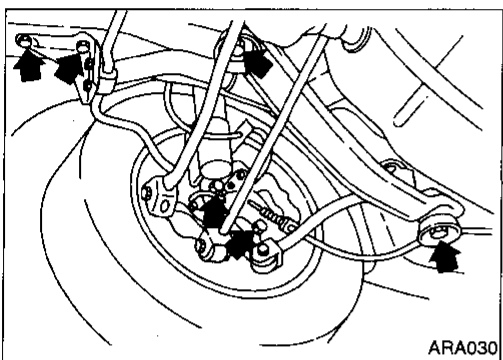
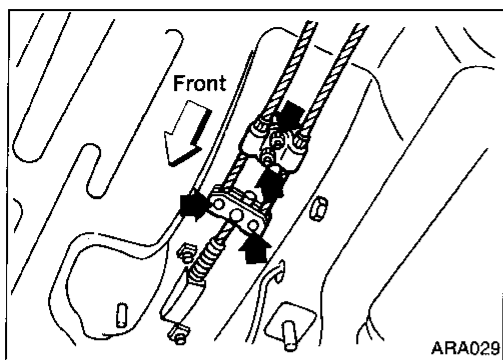

### Removal and Installation

#### CAUTION:

- Do not jack up at the parallel links or radius links.
- Before removing the rear suspension assembly, disconnect the ABS wheel sensor from the assembly. Failure to do so may result in damaged sensor wires and the sensor becoming inoperative.

1. Disconnect brake hydraulic line and parking brake cable at equalizer. (Models with rear drum brake.)

2. Disconnect parking brake cable from caliper. (Models with rear disc brake.)

3. Remove brake caliper assembly. (Models with rear disc brake.)

**Brake hose need not be disconnected from brake caliper. Be careful not to depress brake pedal, or piston will pop out.**

**Make sure brake hose is not twisted.**

4. Remove parking brake cable fixing bolts. (Models with rear drum brake.)

5. Remove stabilizer fixing bolts and suspension member fixing bolts.

6. Remove rear seat. Refer to BT section ("Rear Seat", "SEAT").

7. Remove rear parcel shelf. Refer to BT section ("Side and Floor Trim", "INTERIOR TRIM").

8. Remove strut securing nuts (Upper side). Then pull out strut assembly.

**Do not remove piston rod lock nut on vehicle.**

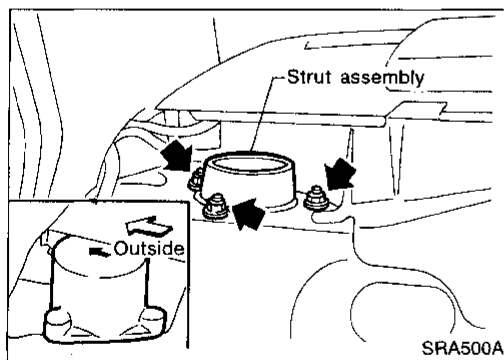

# REAR SUSPENSION — Coil Spring and Strut Assembly

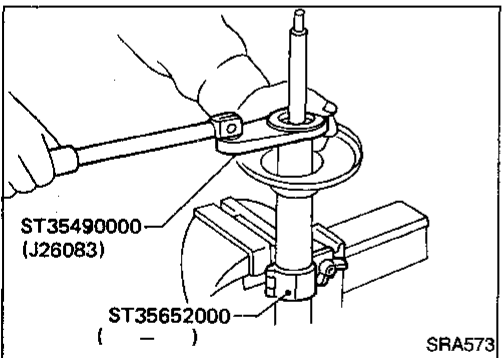
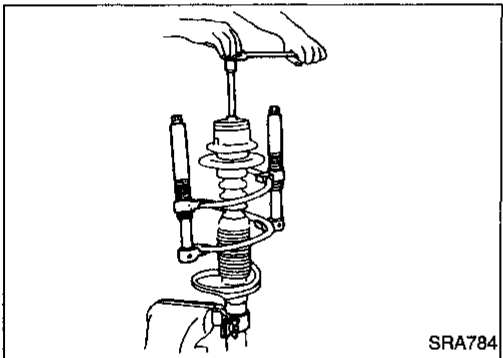
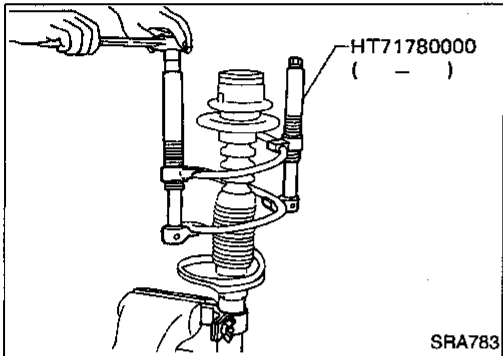
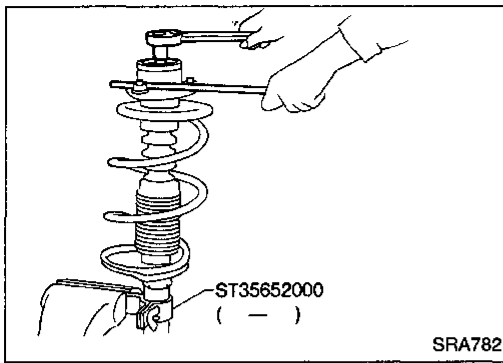

## Disassembly

1. Set strut assembly in vise with attachment, then **loosen** piston rod lock nut.

**Do not remove piston rod lock nut at this time.**

2. Compress spring with Tool so that the strut mounting insulator can be turned by hand.

3. Remove piston rod lock nut.

4. Remove gland packing with Tool.

**Avoid getting dirt and dust into gland packing portion.**

5. Retract piston rod by pushing it down until it bottoms. Then, slowly withdraw piston rod from cylinder together with piston guide.

## Inspection

### STRUT ASSEMBLY

- Check for smooth operation through a full stroke, both compression and extension.
- Check for oil leakage occurring on welded or gland packing portions.
- Check piston rod for cracks, deformation or other damage. Replace if necessary.

GI

MA

EM

LC

EC

FE

CL

MT

AT

FA

**RA**

BR

ST

RS

BT

HA

EL

IDX

# REAR SUSPENSION — Coil Spring and Strut Assembly

## Inspection (Cont'd)

### UPPER RUBBER SEAT AND BUSHING

Check rubber parts for deterioration or cracks.  
Replace if necessary.

### STRUT MOUNTING INSULATOR

- Check cemented rubber-to-metal portion for melting or cracks.
- Check rubber parts for deterioration.

### COIL SPRING

Check for cracks, deformation or other damage.  
Replace if necessary.

## Assembly

1. Locate upper spring seat as shown.

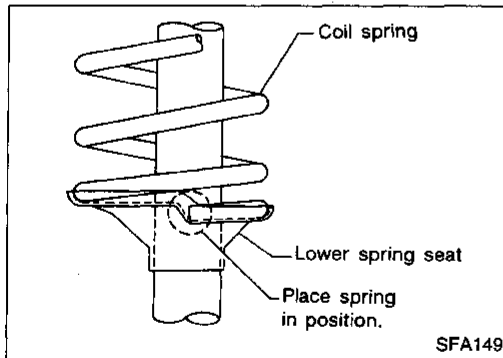
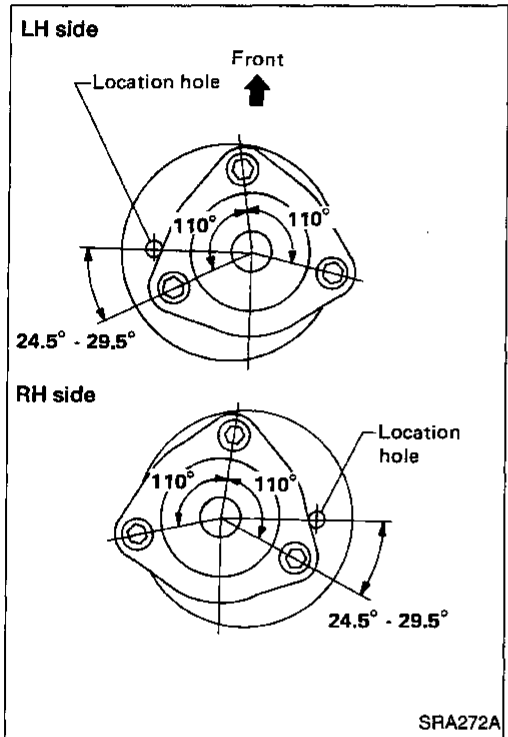

2. After placing coil spring in position on lower spring seat, tighten lock nut. Then gradually release spring compressor.

# REAR SUSPENSION — Parallel Link, Radius Link and Stabilizer Bar

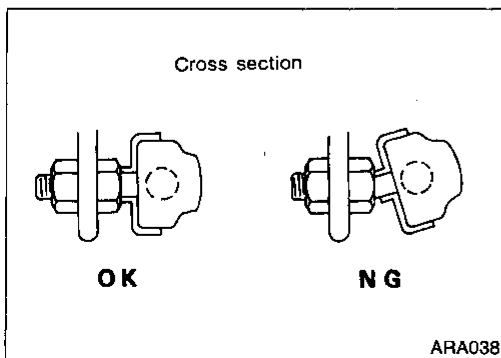
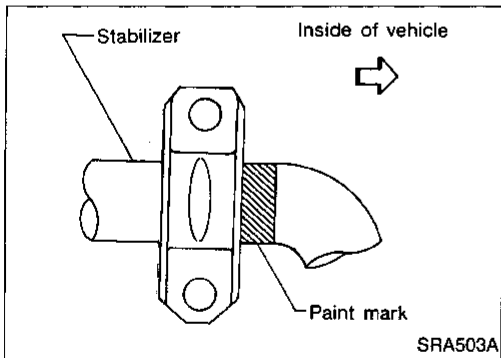
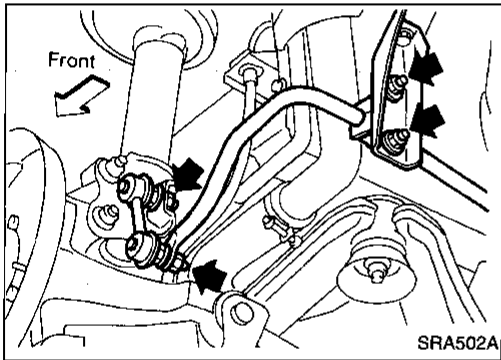
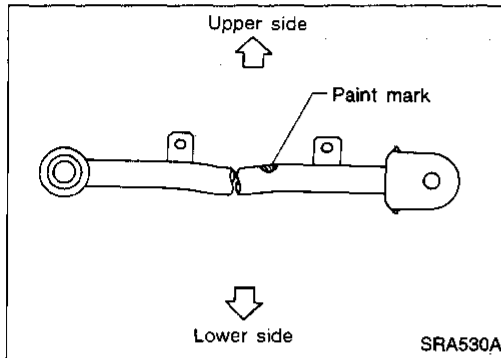
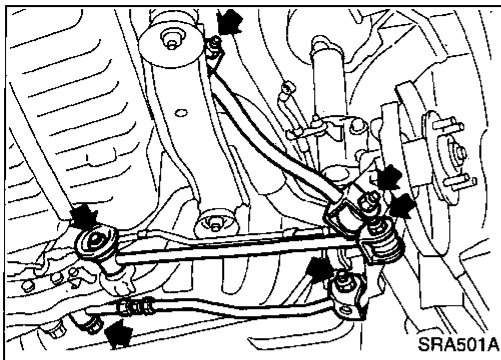

## Removal and Installation

### PARALLEL LINK AND RADIUS LINK

- Remove parallel link and radius link.
- Models without ABS —
- When installing front parallel link, make sure that paint mark faces in the correct direction.
- During installation, final tightening must be carried out at curb weight with tires on the ground.
- After installation, check wheel alignment. Refer to RA-5.
- Check parallel link for cracks, deformation or other damage. Replace if necessary.
- Check radius link for cracks, deformation or other damage. Replace if necessary.

### STABILIZER BAR

- Remove stabilizer bar.
- When installing stabilizer, align paint marks with inside edge of clamps.
- Install stabilizer bar with ball joint socket properly placed.

GI

MA

EM

LC

EC

FE

CL

MT

AT

FA

RA

BR

ST

RS

BT

HA

EL

IDX

# SERVICE DATA AND SPECIFICATIONS (SDS)

## General Specifications

### COIL SPRING

Applied model		XE/GLE/GXE	SE
Wire diameter	mm (in)	12.0 (0.472)	12.2 (0.480)
Coil diameter	mm (in)	142.0 (5.59)	142.4 (5.61)
Free length	mm (in)	327.6 (12.90)	317.2 (12.49)
Spring constant	N/mm (kg/mm, lb/in)	19.6 (2.0, 112)	21.6 (2.2, 123)
Identification color		Yellow x 2	Yellow x 1, Pink x 1

### STABILIZER BAR

Applied model		XE/GLE/GXE	SE
Diameter	mm (in)	15 (0.59)	16 (0.63)

### STRUT

Applied model		XE/GLE/GXE	SE
Piston rod diameter	mm (in)	22 (0.87)	
Damping force [at 0.3 m (1.0 ft)/sec.]	N (kg, lb)		
Expansion		628 - 853 (64 - 87, 141 - 192)	799.3 - 1,083.7 (81.5 - 110.5, 179.7 - 243.7)
Compression		294 - 451 (30 - 46, 66 - 101)	407.0 - 612.9 (41.5 - 62.5, 91.5 - 137.8)

## Inspection and Adjustment

### WHEEL ALIGNMENT (Unladen\*)

Applied model		All
Camber	degree	- 2°00' to -0°30'
Toe-in		
A - B	mm (in)	1 - 3 (0.04 - 0.12)
Total angle 2θ	degree	6' - 18'

\* Fuel, radiator coolant and engine oil full.  
Spare tire, jack, hand tools and mats in designated positions.

### WHEEL BEARING

Applied model		All
Wheel bearing axial end play	mm (in)	0.05 (0.0020) or less
Wheel bearing lock nut tightening torque	N-m (kg-m, ft-lb)	187 - 255 (19.1 - 26, 138 - 188)