

A
B
C

SECTION **PB**

PARKING BRAKE SYSTEM

CONTENTS

<p>PARKING BRAKE SYSTEM 2</p> <p> On-Vehicle Service 2</p> <p> LEVER STROKE 2</p> <p> INSPECT COMPONENTS 2</p> <p> ADJUSTMENT 2</p> <p>PARKING BRAKE CONTROL 3</p> <p> Components 3</p> <p> Removal and Installation 3</p> <p> REMOVAL 3</p> <p> INSTALLATION 3</p>	<p>PARKING BRAKE SHOE 4</p> <p> Components 4</p> <p> Removal and Installation 4</p> <p> REMOVAL 4</p> <p> INSPECTION AFTER REMOVAL 5</p> <p> INSTALLATION 5</p> <p>SERVICE DATA AND SPECIFICATIONS (SDS) 6</p> <p> Parking Drum Brake 6</p> <p> Parking Brake Control 6</p>
--	---

A
B
C
D
E
PB
G
H
I
J
K
L
M

PARKING BRAKE SYSTEM

PARKING BRAKE SYSTEM

PFP:36010

On-Vehicle Service LEVER STROKE

AFS0008Y

- When parking brake lever is operated with a force of 196 N (20 kg, 44 lb), check that the stroke is within the specified number of notches. (Check it by listening and counting the ratchet clicks.)

Lever stroke : 6 to 7 notches

INSPECT COMPONENTS

- Make sure the components are attached properly (check for looseness, backlash, etc.).
- Check parking lever assembly for bend, damage and cracks, and replace if necessary.
- Check that there is no wear or damage to cable, and replace if there is.
- Inspecting parking brake warning lamp switch is inspected and exchange if there is a faulty.

ADJUSTMENT

- To perform adjustment operations, remove tire from vehicle with power tool.

1. Remove ashtray. Insert a deep socket wrench to rotate self-locking nut and loosen the cable sufficiently. Then, return lever.
2. Using wheel nuts, fix disc to hub and prevent it from tilting.

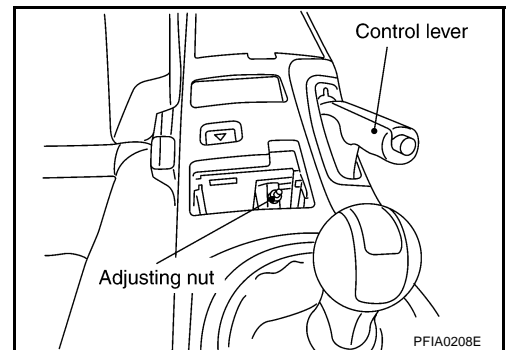

3. Remove adjusting hole plug installed on the disc. Using a screwdriver, turn disc in direction A as shown in the figure until disc is locked. After locking, turn the adjuster in the opposite direction by 5 or 6 notches.
4. Rotate disc to make sure there is no drag. Install the adjusting hole plug.
5. Adjust cable as follows:
 - a. Operate lever 10 or more times with a force of 294 N (30 kg, 66 lb).
 - b. Rotate self-locking nut with deep socket to adjust lever stroke.

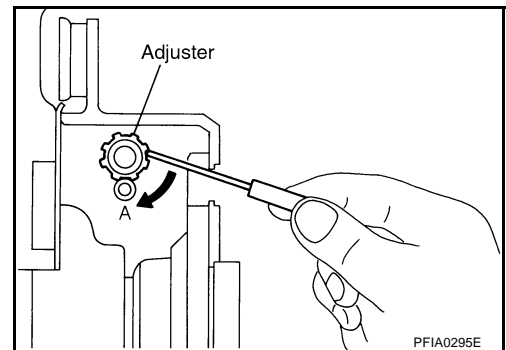

CAUTION:

Do not reuse self-locking nut after removing it.

- c. When parking brake lever is operated with a force of 196 N (20 kg, 44 lb), check that the stroke is within the specified number of notches. (Check it by listening and counting the ratchet clicks.)

Lever stroke : 6 to 7 notches

- d. With lever completely returned, make sure there is no drag on the rear brake.

PARKING BRAKE CONTROL

PARKING BRAKE CONTROL

PF36010

Components

AFS000UZ

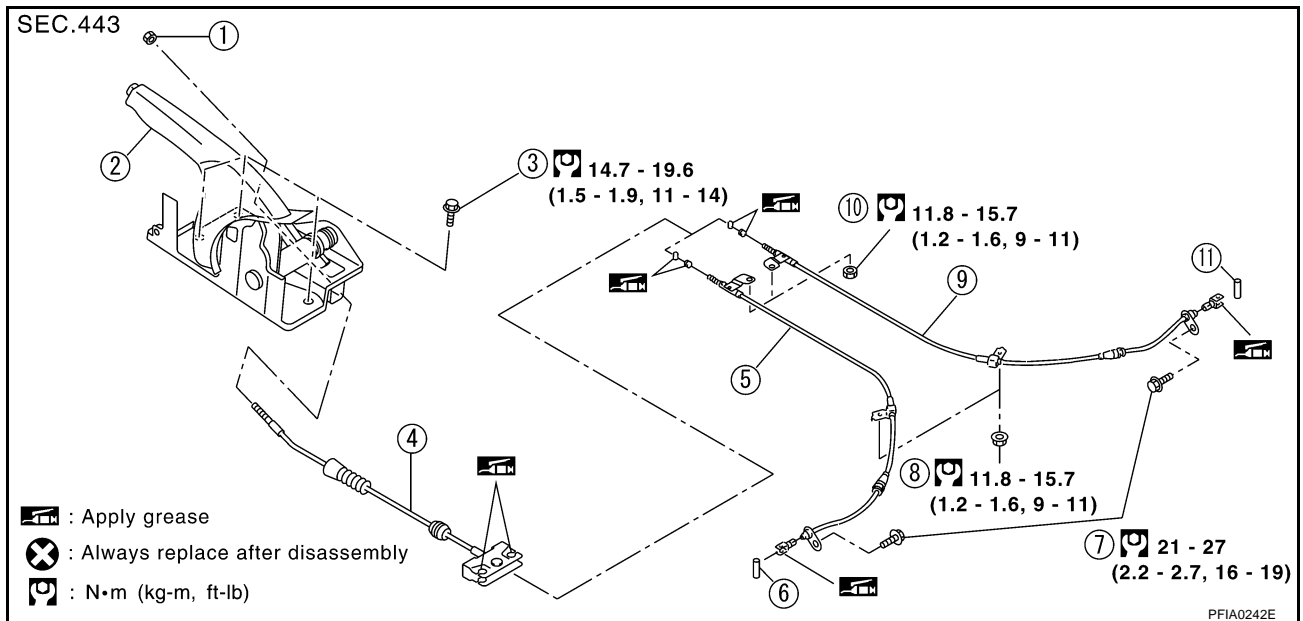

- | | | |
|---------------------|--------------------|---------------------|
| 1. Self-locking nut | 2. Device assembly | 3. Attachment bolt |
| 4. Front cable | 5. Rear left cable | 6. Pin |
| 7. Attachment bolt | 8. Attachment nut | 9. Rear right cable |
| 10. Attachment nut | 11. Pin | |

Removal and Installation

REMOVAL

1. Remove center console. Refer to [IP-10, "INSTRUMENT PANEL ASSEMBLY"](#).
 2. Remove self-locking nut from device assembly.
 3. Remove exhaust center tube. Refer to [EX-3, "EXHAUST SYSTEM"](#).
 4. Remove propeller shaft. Refer to [PR-5, "REAR PROPELLER SHAFT"](#).
- CAUTION:**
Do not impact or damage propeller shaft tube.
5. Remove rear disc caliper and disc rotors. Refer to [BR-27, "Removal and Installation of Caliper Assembly"](#).
 6. Remove parking brake shoe, and remove rear cable from toggle lever. Refer to [PB-4, "PARKING BRAKE SHOE"](#).
 7. Remove cable nuts.
 8. Remove right and left rear cables.
 9. Remove front cable nuts and bolts, and remove front cable.
 10. Remove device assembly bolt and remove device assembly from vehicle.

INSTALLATION

1. Refer to "Component Parts Location" for tightening torque. Install in the reverse order of removal.
CAUTION:
Since self-locking nut is not a reusable part, do not reuse it.
2. Adjust parking brake. Refer to [PB-2, "ADJUSTMENT"](#).

PARKING BRAKE SHOE

PARKING BRAKE SHOE

PFP:44060

Components

AFS000V0

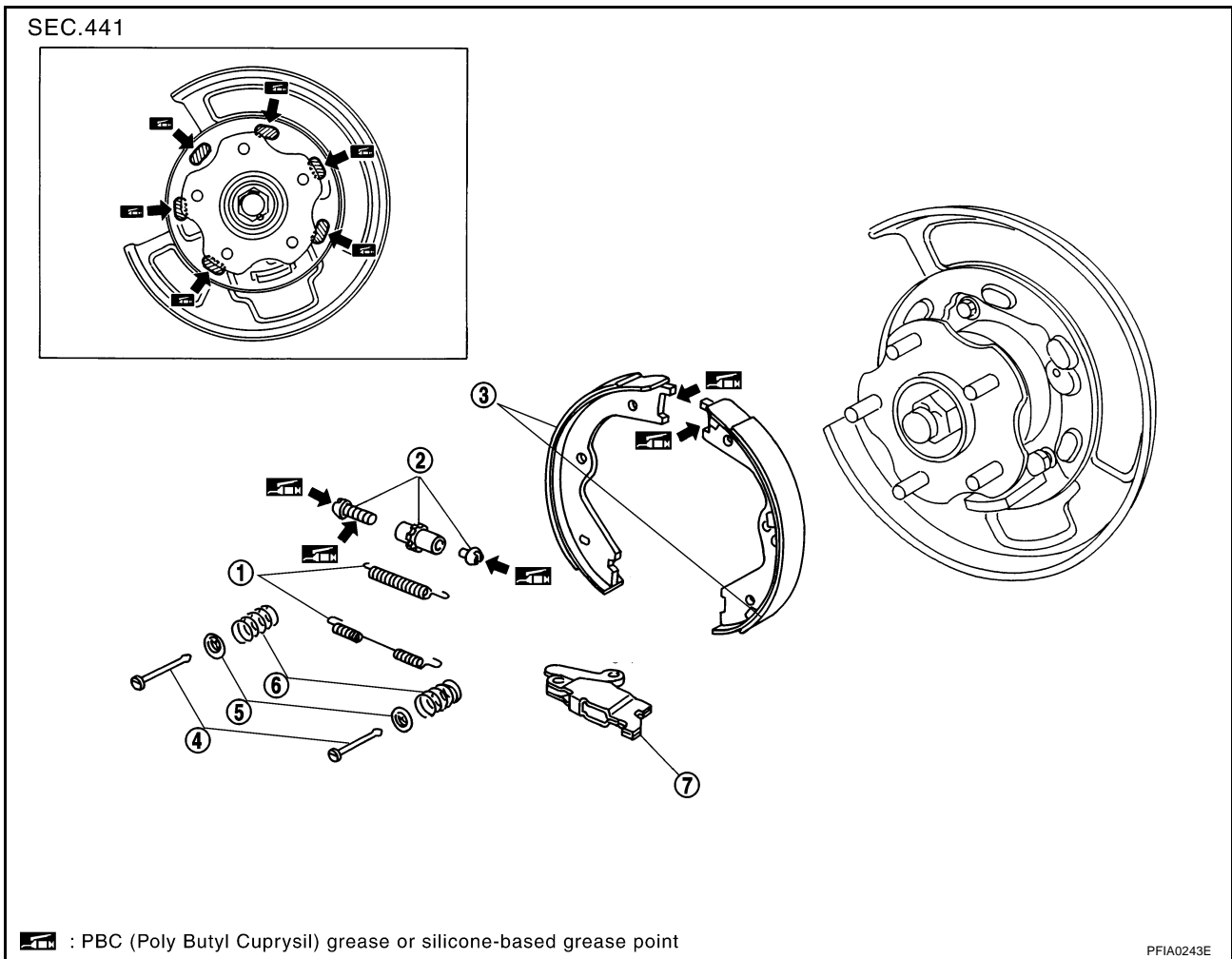

1. Return spring
4. Anti-rattle pin
7. Toggle lever

2. Adjuster assembly
5. Retainer

3. Shoe
6. Anti-rattle spring

Removal and Installation

REMOVAL

AFS0010M

CAUTION:

Clean dust on the disc and back plate with a vacuum dust collector. Do not blow with compressed air. Be careful of the following:

- Remove the disc rotor only with the parking brake lever completely in the returned position.
 - If disc rotor cannot be removed, remove as follows:
1. Fix disc rotor in place with wheel nuts and remove disc rotor plug. Using a screwdriver, rotate star wheel on the adjuster assembly in direction B to retract and loosen brake shoes.

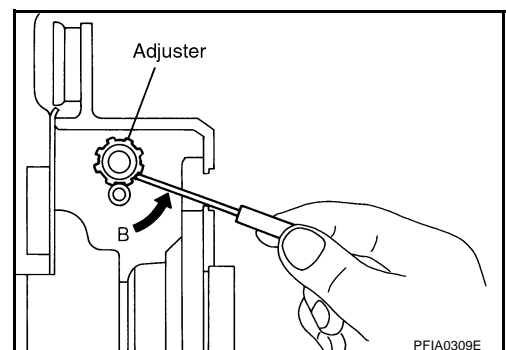

PARKING BRAKE SHOE

INSPECTION AFTER REMOVAL

Lining Thickness Inspection

- Check the thickness of the lining.

Standard

Standard thickness (A) : 3.2 mm (0.126 in)

Repair limit thickness (A) : 1.5 mm (0.059 in)

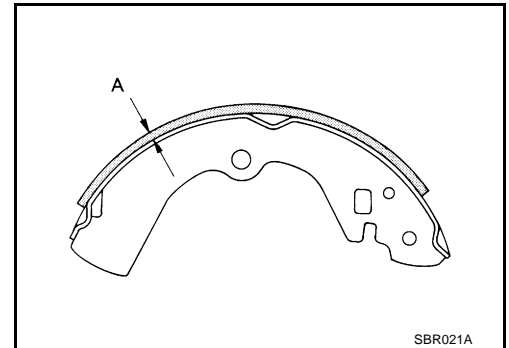

Drum Inner Diameter Inspection

- Check the inner diameter of the drum.

Standard

Standard inner diameter : 172 mm (6.77 in) dia.

Maximum inner diameter : 173 mm (6.81 in) dia.

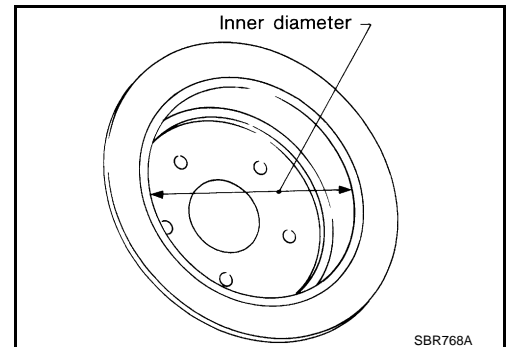

Other Inspections

- Check shoe sliding surface for excessive wear and damage.
- Check anchor pin for excessive wear and corrosion.
- Check return spring for sagging.
- Does adjuster move smoothly?
- Check either visually or with a vernier caliper to see if there is any excessive wear, cracks, or damage inside drum.

INSTALLATION

Be careful of the following:

- Refer to "Component Parts Location" and apply brake grease to the specified points during assembly.
 - Orientation of the adjuster is different from left to right. Assemble adjuster so that threaded part expands when rotating it in the direction shown by the arrow.
 - Collapse adjuster to assemble
 - When disassembling adjuster, apply PBC (Poly Butyl Cuprysil) grease or silicone based grease to the threads.
 - After replacing brake shoes or disc rotors, or if brakes do not function well, perform break-in operation as follows.
1. Adjust the parking brake lever stroke to the specified stroke.
 2. Perform parking brake break-in (drag run) operation by driving the vehicle under the following conditions:

Drive forward

- **Vehicle speed approx. 35 km/h (22 MPH) set (forward)**
- **Parking brake operating force approx. 147 N (15 kg, 33 lb) set**
- **Distance approx. 100 m (328 ft)**
- **Repeat three times. [Total 300 m (984 ft)]**

3. After break-in operation, check lever stroke of the parking brake. Readjust if it is no longer at the specified stroke.
 - To prevent lining from getting too hot, allow a cool off period of approximately 5 minutes after every break-in operation.
 - Do not perform excessive break-in operations, because it may cause uneven or early wear of the lining.

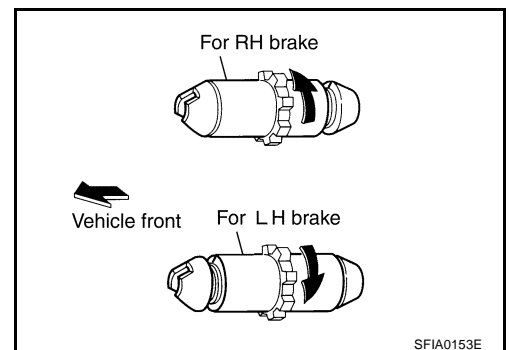

SERVICE DATA AND SPECIFICATIONS (SDS)

SERVICE DATA AND SPECIFICATIONS (SDS)

PFP:00030

Parking Drum Brake

AFS00095

Type		DS17HG
Brake lining	Standard thickness (new)	3.2 mm (0.126 in)
	Wear limit thickness	1.5 mm (0.059 in)
Drum (disc)	Standard inner diameter (new)	172 mm (6.77 in)
	Wear limit of inner diameter	173 mm (6.81 in)

Parking Brake Control

AFS00096

Control type	Center lever
Number of notches [under force of 196 N (20 kg,44 lb)]	6 - 7 notches
Number of notches when warning lamp switch comes on	1 notches