

SECTION **PG**

POWER SUPPLY, GROUND & CIRCUIT ELEMENTS

CONTENTS

APPLICATION NOTICE	3	OPERATION PROCEDURE	35
How to Check Vehicle Type	3	INSPECTION IN AUTO ACTIVE TEST MODE ...	35
PRECAUTIONS	4	Schematic/Type 1	37
Precautions for Battery Service	4	Schematic/Type 2	38
POWER SUPPLY ROUTING CIRCUIT	5	IPDM E/R Terminal Arrangement/Type 1	39
Schematic/Type 1	5	IPDM E/R Terminal Arrangement/Type 2	40
Wiring Diagram — POWER —/Type 1	6	IPDM E/R Power/Ground Circuit Inspection	41
BATTERY POWER SUPPLY — IGNITION SW.		Inspection With CONSULT-II (Self-Diagnosis)	42
IN ANY POSITION	6	Removal and Installation of IPDM E/R	43
ACCESSORY POWER SUPPLY — IGNITION		REMOVAL	43
SW. IN “ACC” OR “ON”	11	INSTALLATION	43
IGNITION POWER SUPPLY — IGNITION SW.		GROUND	44
IN “ON” AND/OR “START”	12	Ground Distribution	44
Schematic/Type 2	17	MAIN HARNESS/TYP E 1	44
Wiring Diagram — POWER —/Type 2	18	MAIN HARNESS/TYP E 2	46
BATTERY POWER SUPPLY — IGNITION SW.		ENGINE ROOM HARNESS/TYP E 1	48
IN ANY POSITION	18	ENGINE ROOM HARNESS/TYP E 2	51
ACCESSORY POWER SUPPLY — IGNITION		ENGINE CONTROL HARNESS/TYP E 1	54
SW. IN “ACC” OR “ON”	23	ENGINE CONTROL HARNESS/TYP E 2	56
IGNITION POWER SUPPLY — IGNITION SW.		BODY HARNESS/TYP E 1	58
IN “ON” AND/OR “START”	24	BODY HARNESS/TYP E 2	63
Fuse	29	BODY NO. 2 HARNESS/TYP E 1	66
Fusible Link	29	BODY NO. 2 HARNESS/TYP E 2	67
Circuit Breaker	29	TAIL HARNESS/TYP E 1	68
IPDM E/R (INTELLIGENT POWER DISTRIBUTION		TAIL HARNESS/TYP E 2	70
MODULE ENGINE ROOM)	30	BACK DOOR HARNESS	72
System Description	30	HARNESS	73
SYSTEMS CONTROLLED BY IPDM E/R	30	Harness Layout	73
CAN COMMUNICATION LINE CONTROL	30	HOW TO READ HARNESS LAYOUT	73
IPDM E/R STATUS CONTROL	31	OUTLINE	74
CAN Communication System Description	31	MAIN HARNESS/TYP E 1	75
CAN Communication Unit	31	MAIN HARNESS/TYP E 2	77
Function of Detecting Ignition Relay Malfunction ...	31	ENGINE ROOM HARNESS/TYP E 1	79
CONSULT-II Function (IPDM E/R)	32	ENGINE ROOM HARNESS/TYP E 2	83
CONSULT-II BASIC OPERATION	32	ENGINE CONTROL HARNESS/TYP E 1	87
SELF-DIAG RESULTS	32	ENGINE CONTROL HARNESS/TYP E 2	90
DATA MONITOR	33	BODY HARNESS/TYP E 1	93
ACTIVE TEST	34	BODY HARNESS/TYP E 2	98
Auto Active Test	35	BODY NO. 2 HARNESS/TYP E 1	103
DESCRIPTION	35	BODY NO. 2 HARNESS/TYP E 2	104

TAIL HARNESS/TYPE 1	105	TYPE)	131
TAIL HARNESS/TYPE 2	108	HARNESS CONNECTOR (LEVER LOCKING	
TAIL NO. 2 HARNESS	111	TYPE)	132
ROOM LAMP HARNESS/TYPE 1	112	ELECTRICAL UNITS	133
ROOM LAMP HARNESS/TYPE 2	114	Terminal Arrangement/Type 1	133
DOOR HARNESS	116	Terminal Arrangement/Type 2	135
Wiring Diagram Codes (Cell Codes)	118	SMJ (SUPER MULTIPLE JUNCTION)	137
ELECTRICAL UNITS LOCATION	121	Terminal Arrangement	137
Electrical Units Location	121	STANDARDIZED RELAY	139
ENGINE COMPARTMENT	121	Description	139
PASSENGER COMPARTMENT/TYPE 1	122	NORMAL OPEN, NORMAL CLOSED AND	
PASSENGER COMPARTMENT/TYPE 2	125	MIXED TYPE RELAYS	139
LUGGAGE COMPARTMENT	128	TYPE OF STANDARDIZED RELAYS	139
HARNESS CONNECTOR	130	FUSE BLOCK - JUNCTION BOX (J/B)	141
Description	130	Terminal Arrangement	141
HARNESS CONNECTOR (TAB-LOCKING		FUSE, FUSIBLE LINK AND RELAY BOX	142
TYPE)	130	Terminal Arrangement	142
HARNESS CONNECTOR (SLIDE-LOCKING			

APPLICATION NOTICE

APPLICATION NOTICE

PFP:00000

How to Check Vehicle Type

NKS004S9

Check the vehicle identification number (chassis number).

Identification number (chassis number)	Service information
<p>For serial</p> <ul style="list-style-type: none">● JN1AZ34D300001 – JN1AZ34D330000● JN1AZ34E350001 – JN1AZ34E380000● JN1AZ36D400001 – JN1AZ36D430000● JN1AZ36A450001 – JN1AZ36A480000	Type 1
<p>From serial</p> <ul style="list-style-type: none">● JN1AZ34D330001 –● JN1AZ34E380001 –● JN1AZ36D430001 –● JN1AZ36A480001 –	Type 2

A
B
C
D
E
F
G
H
I
J
L
M

PG

PRECAUTIONS

PRECAUTIONS

PFP:00001

Precautions for Battery Service

NKS0054E

Before disconnecting the battery, lower both the driver and passenger windows. This will prevent any interference between the window edge and the vehicle when the door is opened/closed. During normal operation, the window slightly raises and lowers automatically to prevent any window to vehicle interference. The automatic window function will not work with the battery disconnected.

POWER SUPPLY ROUTING CIRCUIT

NKS000E0

Wiring Diagram — POWER —/Type 1 BATTERY POWER SUPPLY — IGNITION SW. IN ANY POSITION

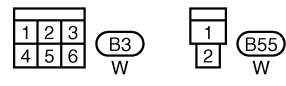
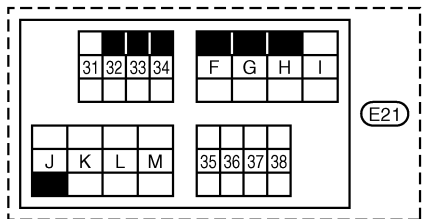
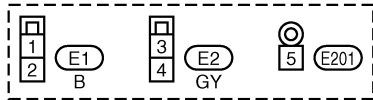
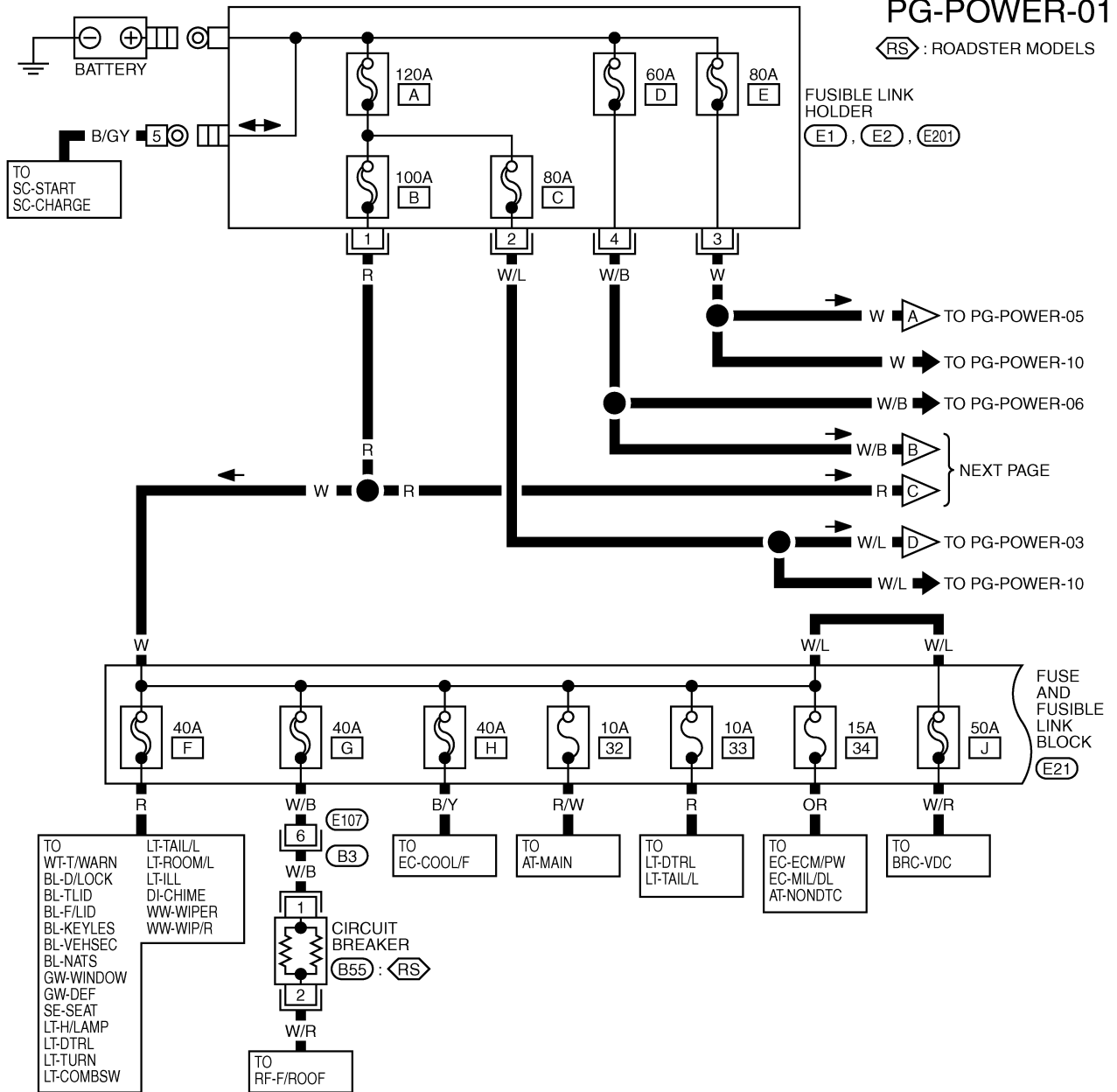

TKWT4102E

POWER SUPPLY ROUTING CIRCUIT

PG-POWER-02

PRECEDING PAGE

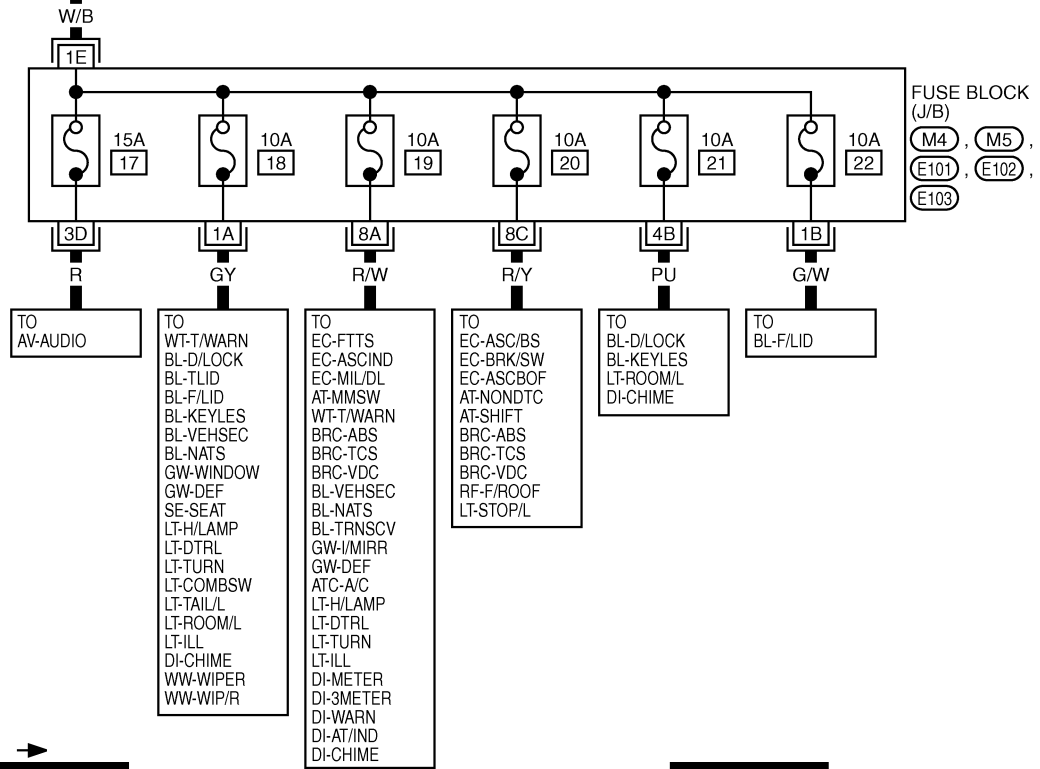

PRECEDING PAGE

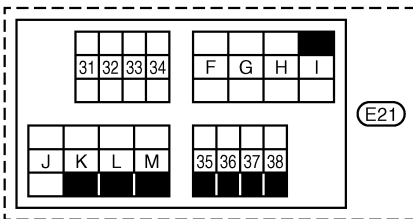
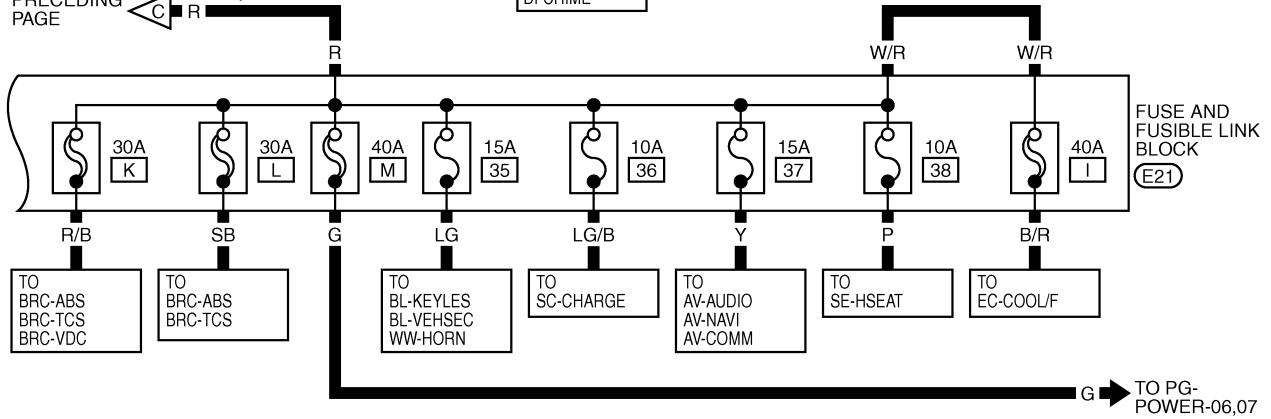

REFER TO THE FOLLOWING.

(M4), (M5), (E101), (E102),
 (E103) - FUSE BLOCK-JUNCTION BOX (J/B)

1	2	3	4	5	6	7	8	9	10	11
12	13	14	15	16	17	18	19	20	21	22

TKWT4103E

POWER SUPPLY ROUTING CIRCUIT

PG-POWER-03

U : FOR U.S.A.

C : FOR CANADA

*1 20A : U

30A : C

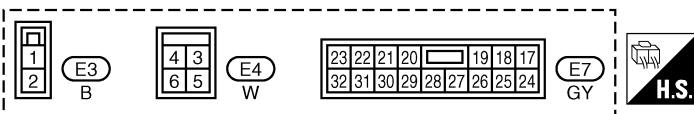
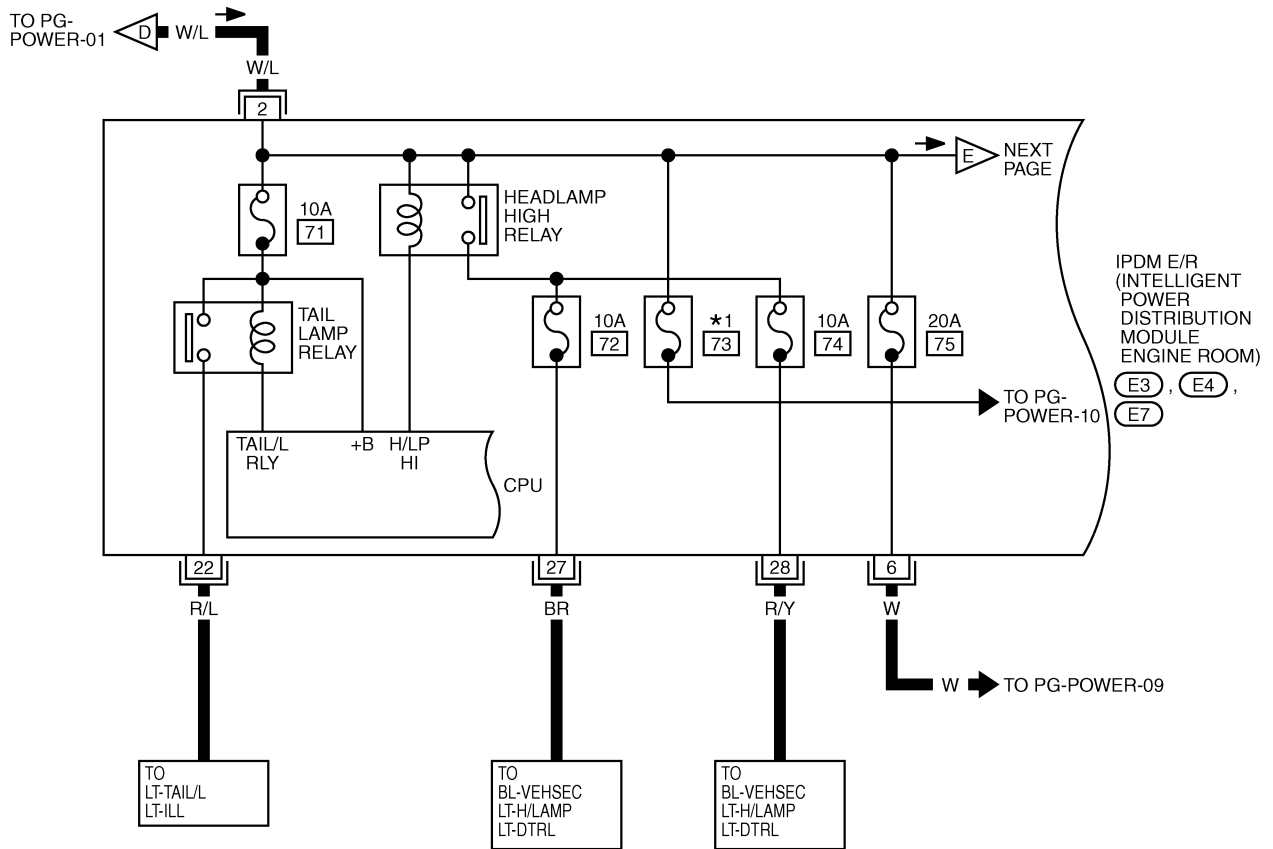

TKWT4104E

POWER SUPPLY ROUTING CIRCUIT

PG-POWER-04

A
B
C
D
E
F
G
H
I
J
PG
L
M

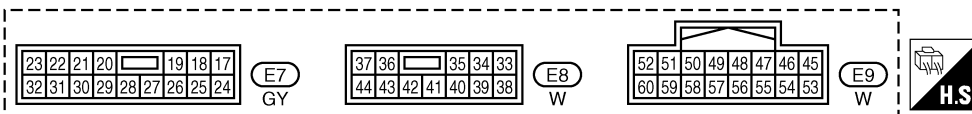
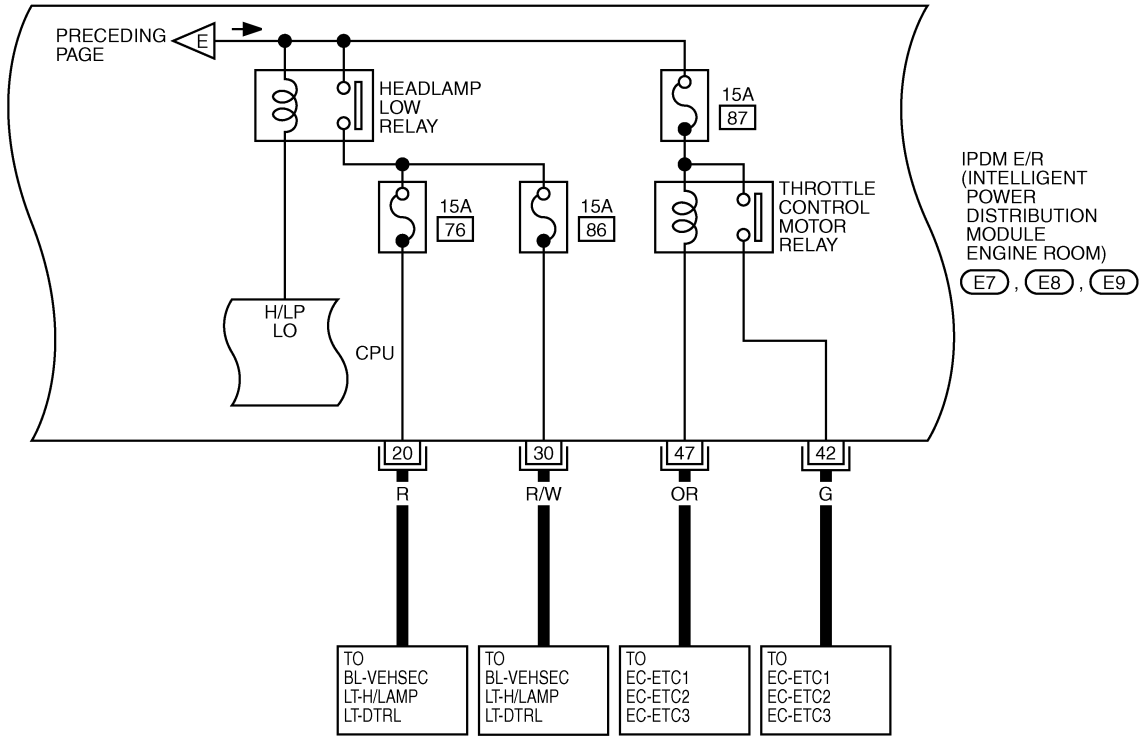

TKWT4105E

POWER SUPPLY ROUTING CIRCUIT

PG-POWER-05

TO PG-POWER-01

▬ : DATA LINE

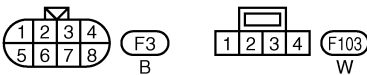
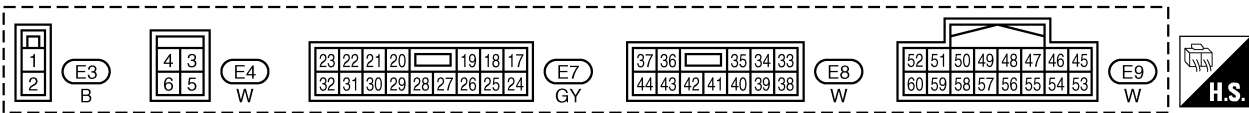
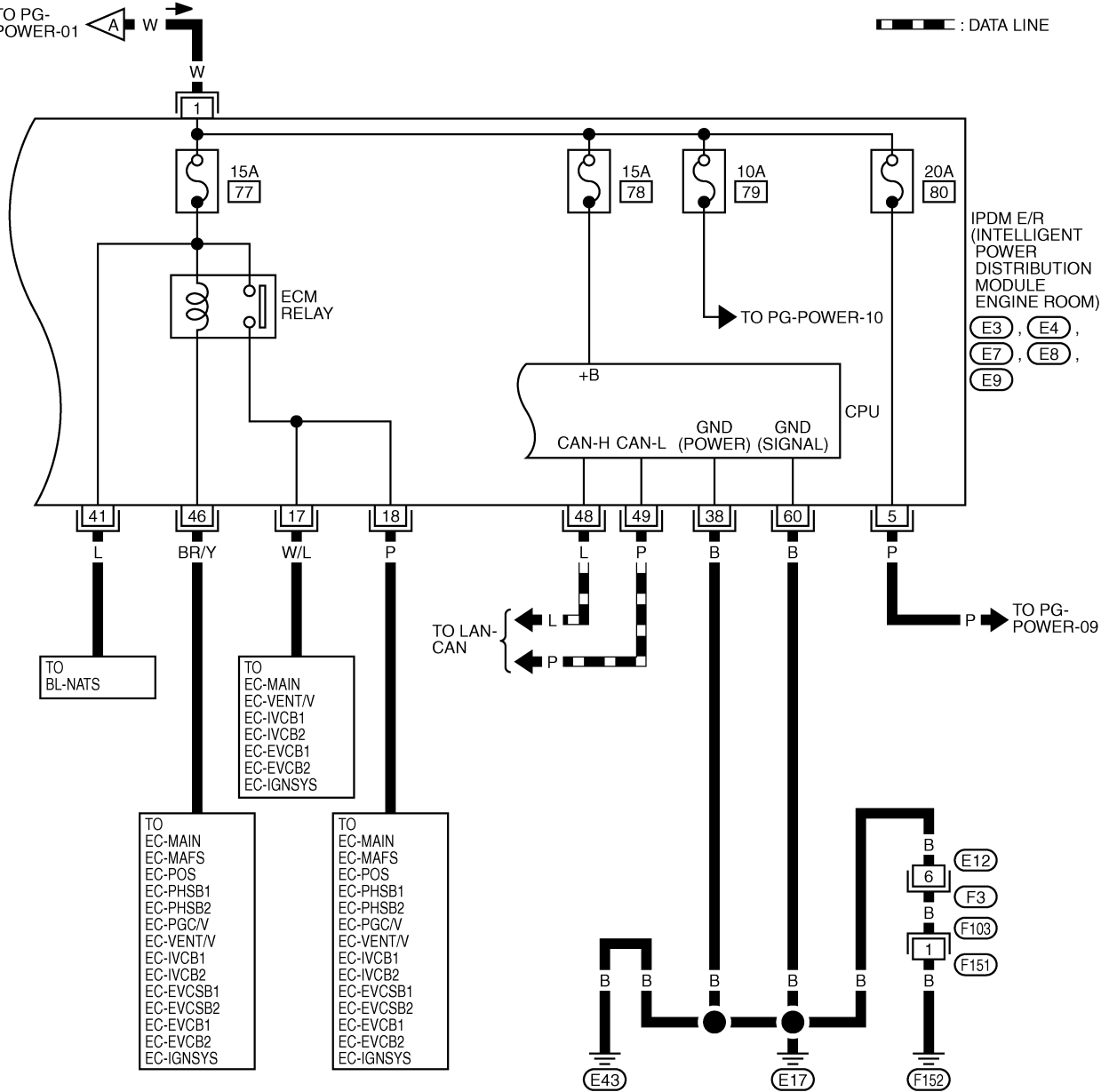

TKWT4106E

POWER SUPPLY ROUTING CIRCUIT

ACCESSORY POWER SUPPLY — IGNITION SW. IN “ACC” OR “ON”

PG-POWER-06

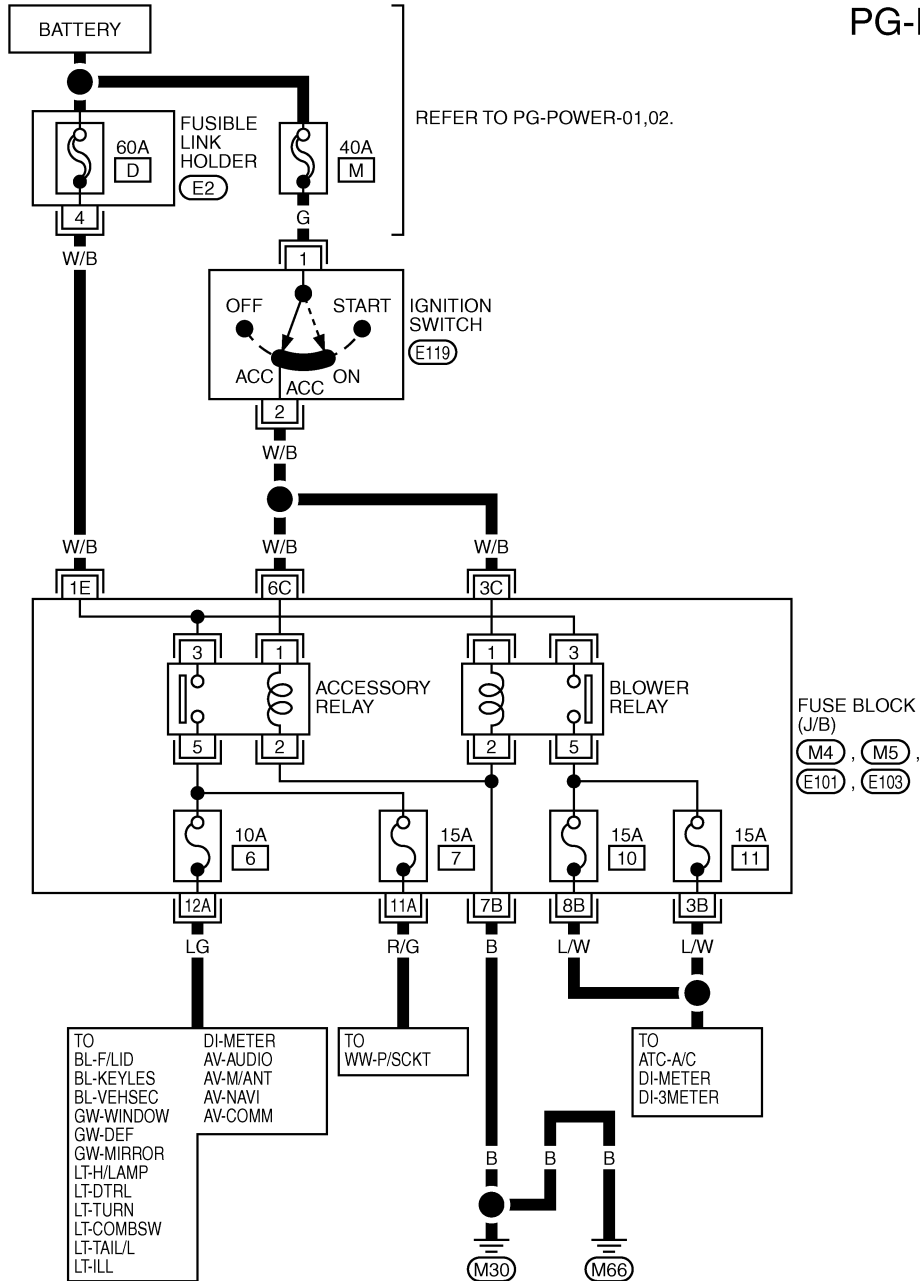

FUSE BLOCK (J/B)
 (M4), (M5),
 (E101), (E103)

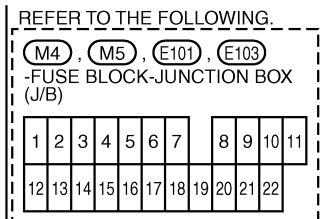
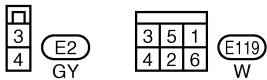

TKWT4107E

POWER SUPPLY ROUTING CIRCUIT

IGNITION POWER SUPPLY — IGNITION SW. IN “ON” AND/OR “START”

PG-POWER-07

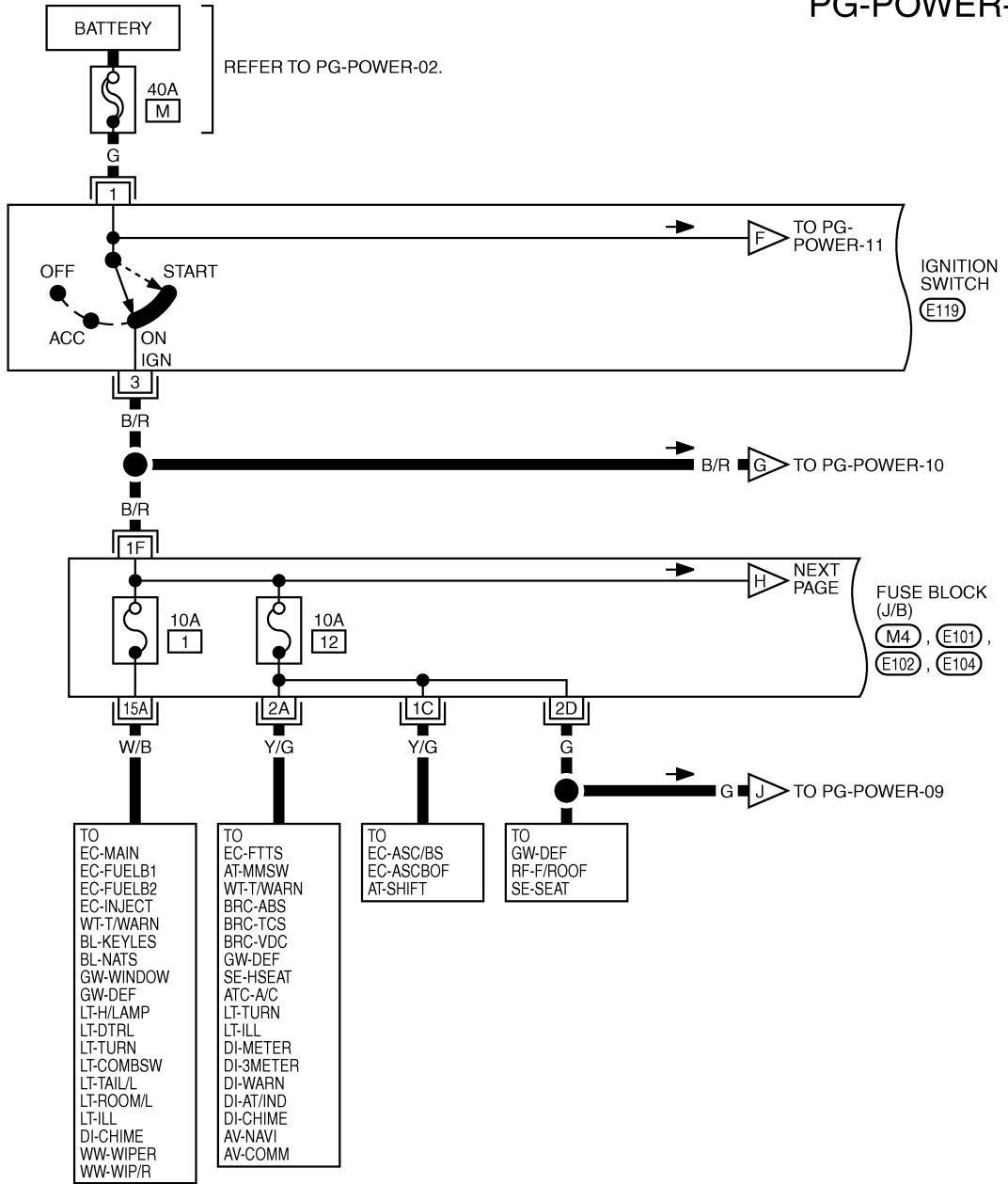

3	5	1
4	2	6

(E119)
W

REFER TO THE FOLLOWING.

(M4), (E101), (E102), (E104)
 -FUSE BLOCK-JUNCTION BOX (J/B)

1	2	3	4	5	6	7	8	9	10	11
12	13	14	15	16	17	18	19	20	21	22

TKWT4108E

POWER SUPPLY ROUTING CIRCUIT

PG-POWER-08

A
B
C
D
E
F
G
H
I
J
L
M

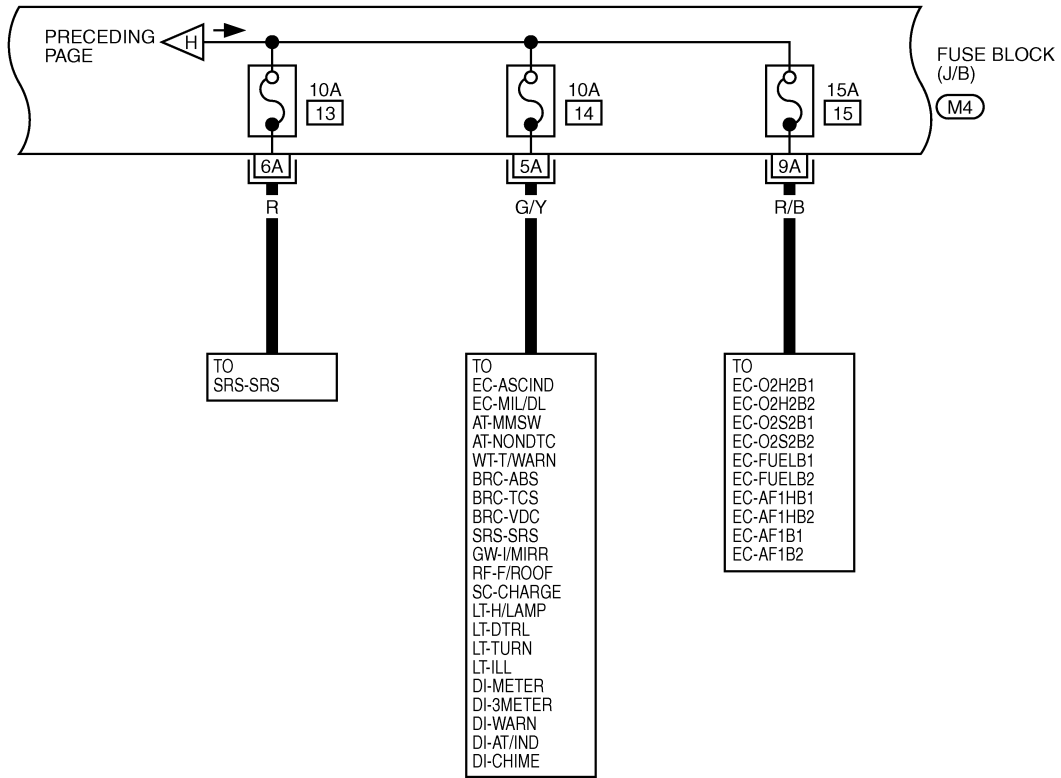

PG

REFER TO THE FOLLOWING.

(M4) - FUSE BLOCK-
JUNCTION BOX (J/B)

1	2	3	4	5	6	7	8	9	10	11
12	13	14	15	16	17	18	19	20	21	22

TKWM1379E

POWER SUPPLY ROUTING CIRCUIT

PG-POWER-09

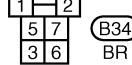
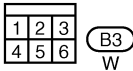
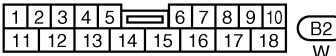
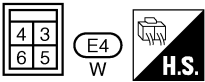
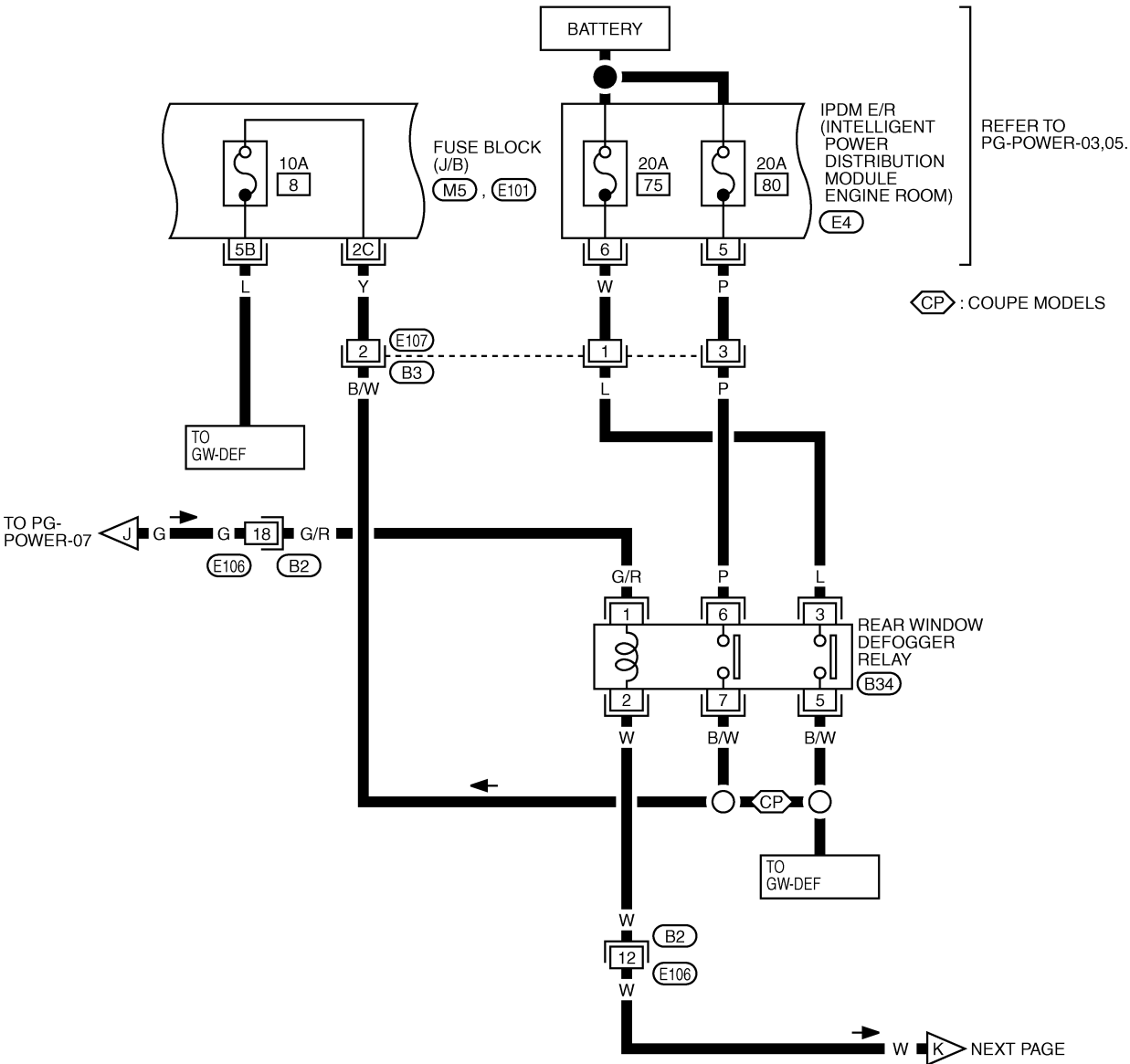

REFER TO THE FOLLOWING

(M5), (E101) - FUSE BLOCK- JUNCTION BOX (J/B)

1	2	3	4	5	6	7	8	9	10	11
12	13	14	15	16	17	18	19	20	21	22

TKWT4109E

POWER SUPPLY ROUTING CIRCUIT

PG-POWER-10

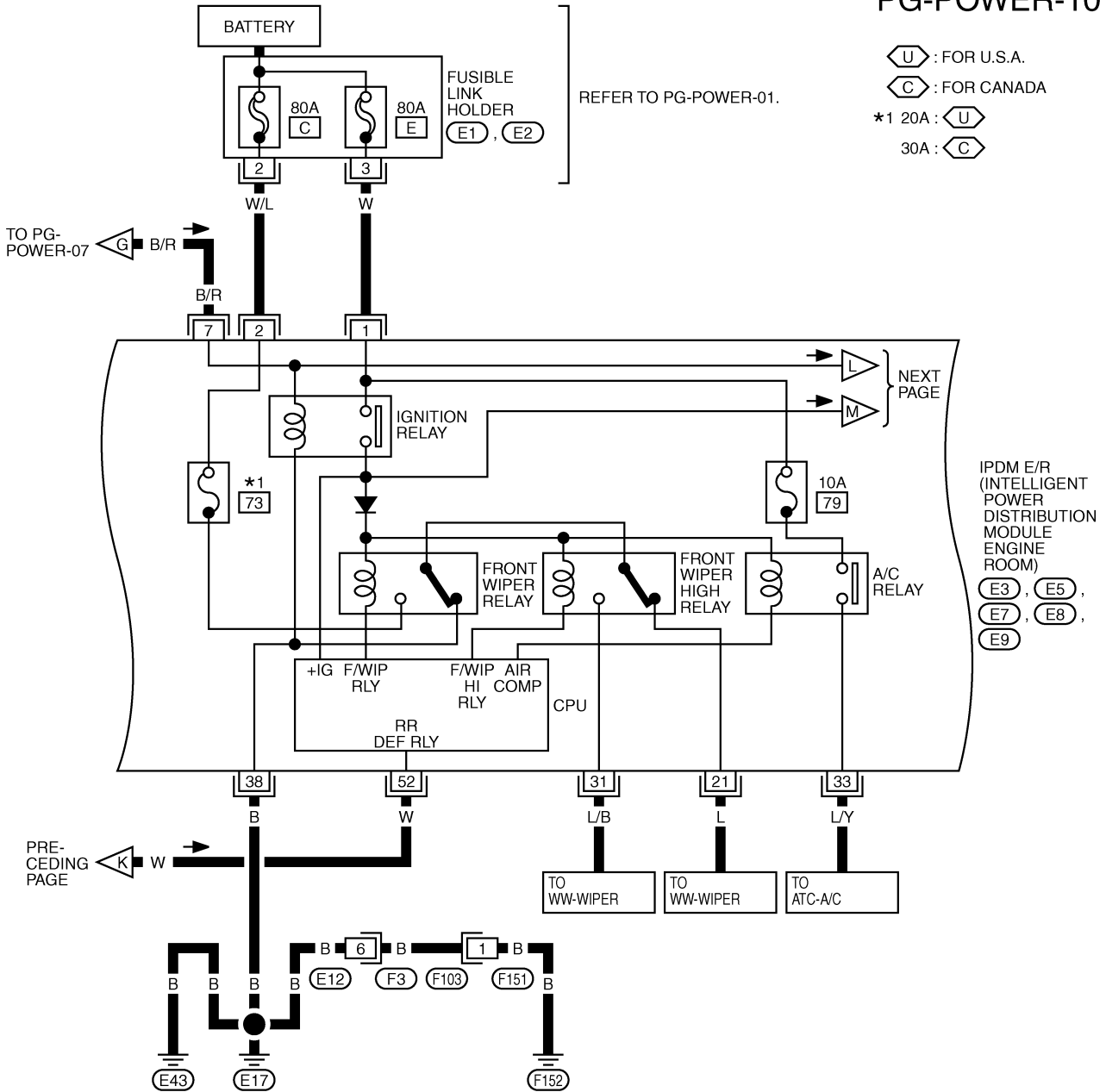

U : FOR U.S.A.
 C : FOR CANADA
 *1 20A: U
 30A: C

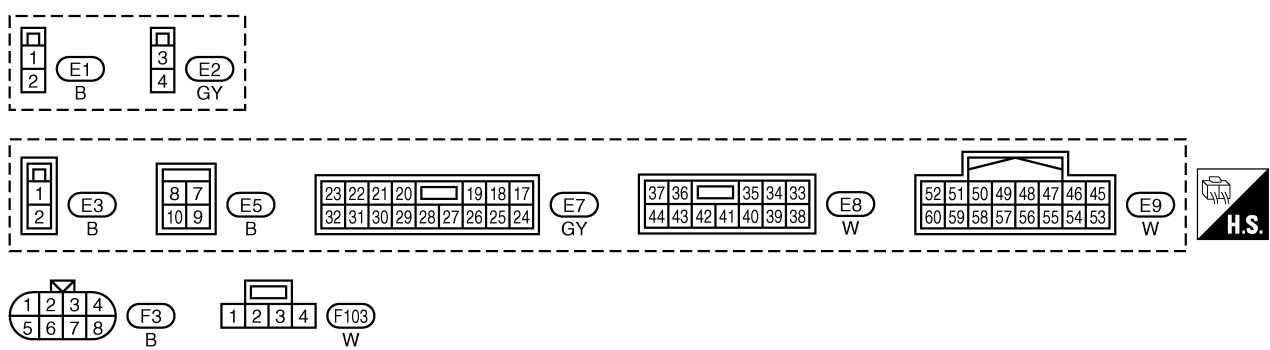

TKWT4110E

POWER SUPPLY ROUTING CIRCUIT

PG-POWER-11

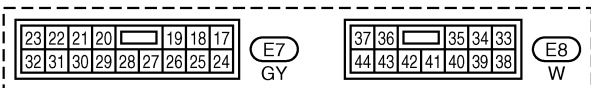
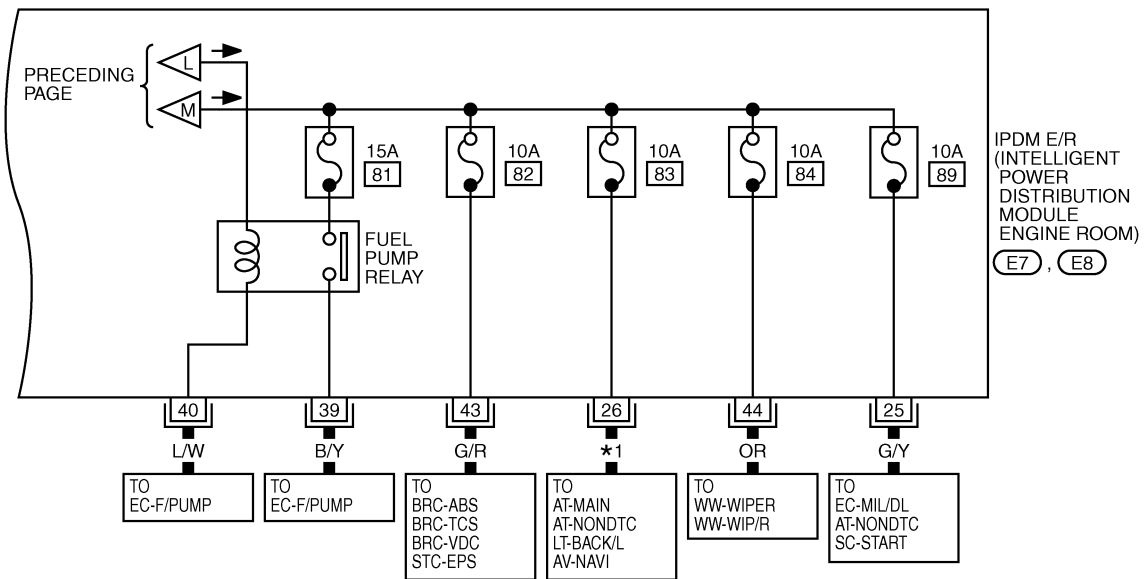
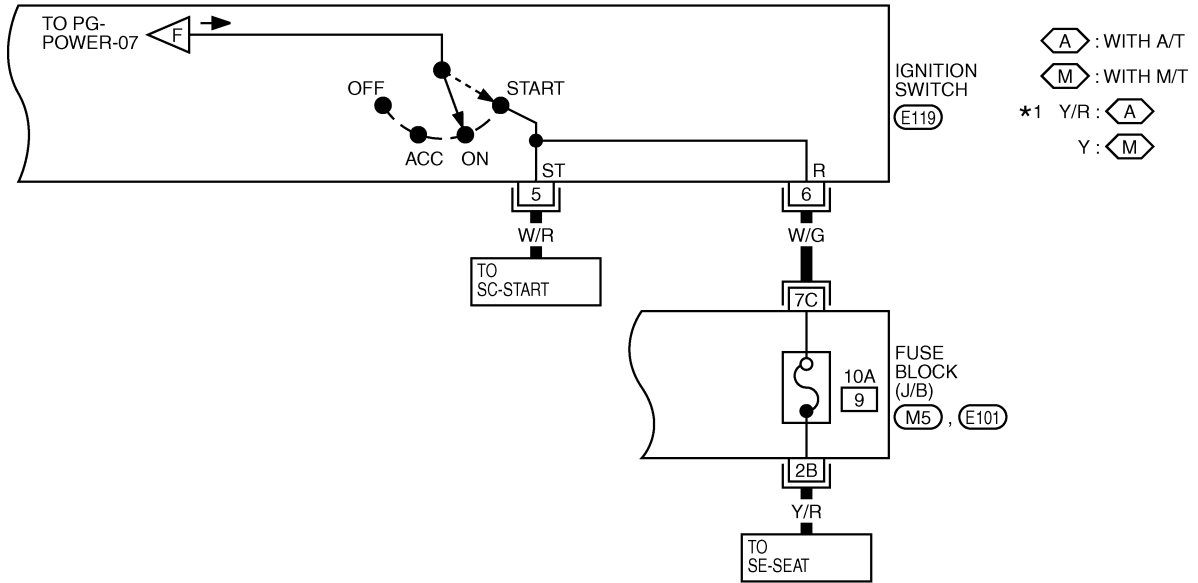

REFER TO THE FOLLOWING.

(M5, E101) - FUSE BLOCK-JUNCTION BOX (J/B)

1	2	3	4	5	6	7	8	9	10	11
12	13	14	15	16	17	18	19	20	21	22

TKWT4111E

POWER SUPPLY ROUTING CIRCUIT

Schematic/Type 2

NKS004SX

A
B
C
D
E
F
G
H
I
J
PG
L
M

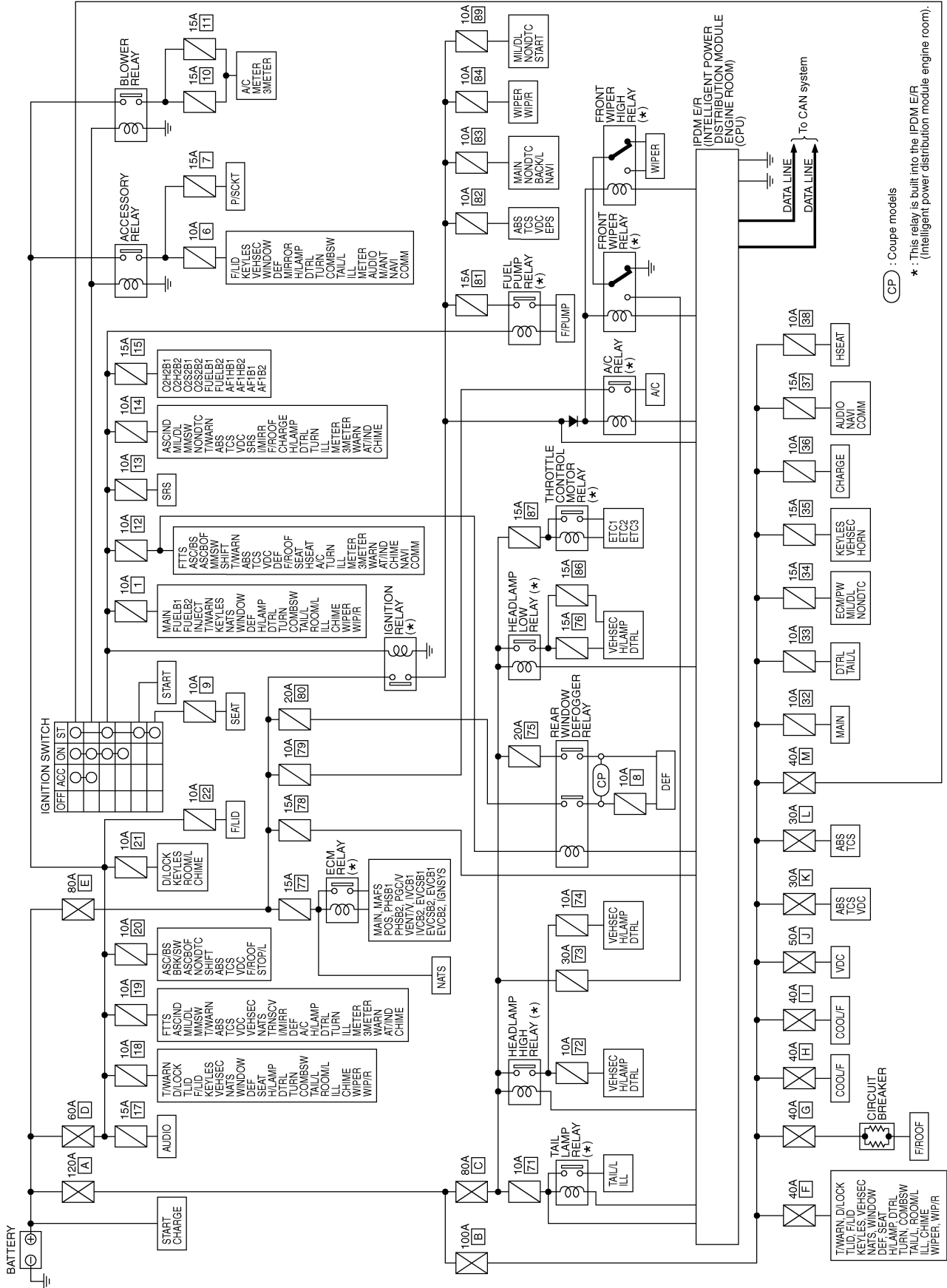

CP : Coupe models

* : This relay is built into the IPDM E/R (intelligent power distribution module engine room).

TKWT5636E

POWER SUPPLY ROUTING CIRCUIT

Wiring Diagram — POWER —/Type 2 BATTERY POWER SUPPLY — IGNITION SW. IN ANY POSITION

NKS004SY

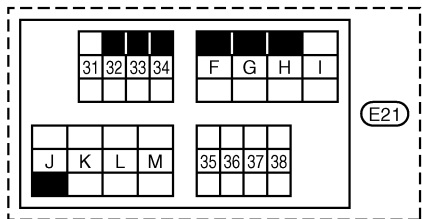
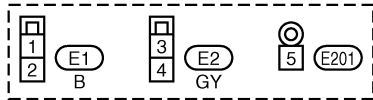
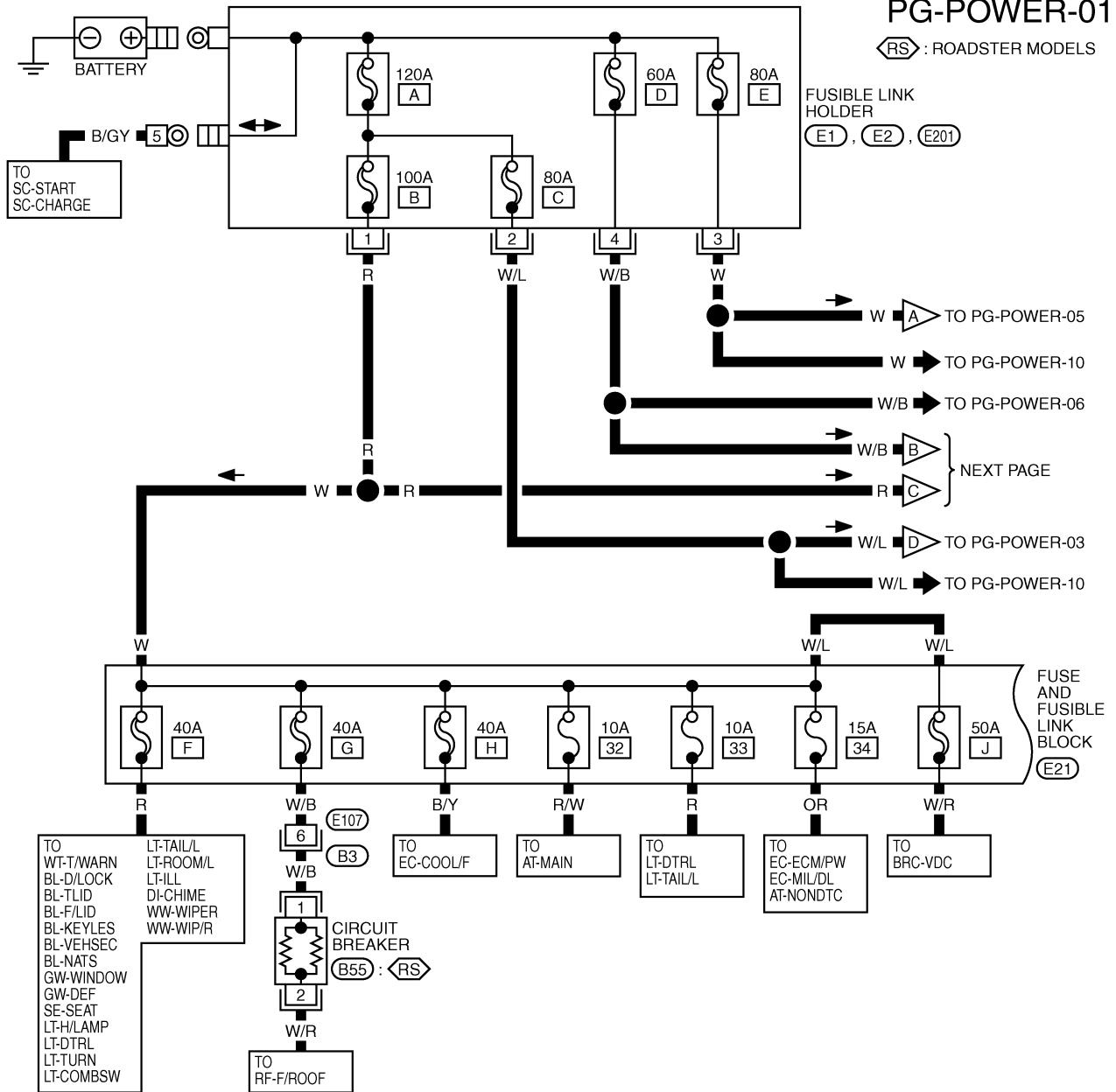



TKWT4102E

POWER SUPPLY ROUTING CIRCUIT

PG-POWER-02

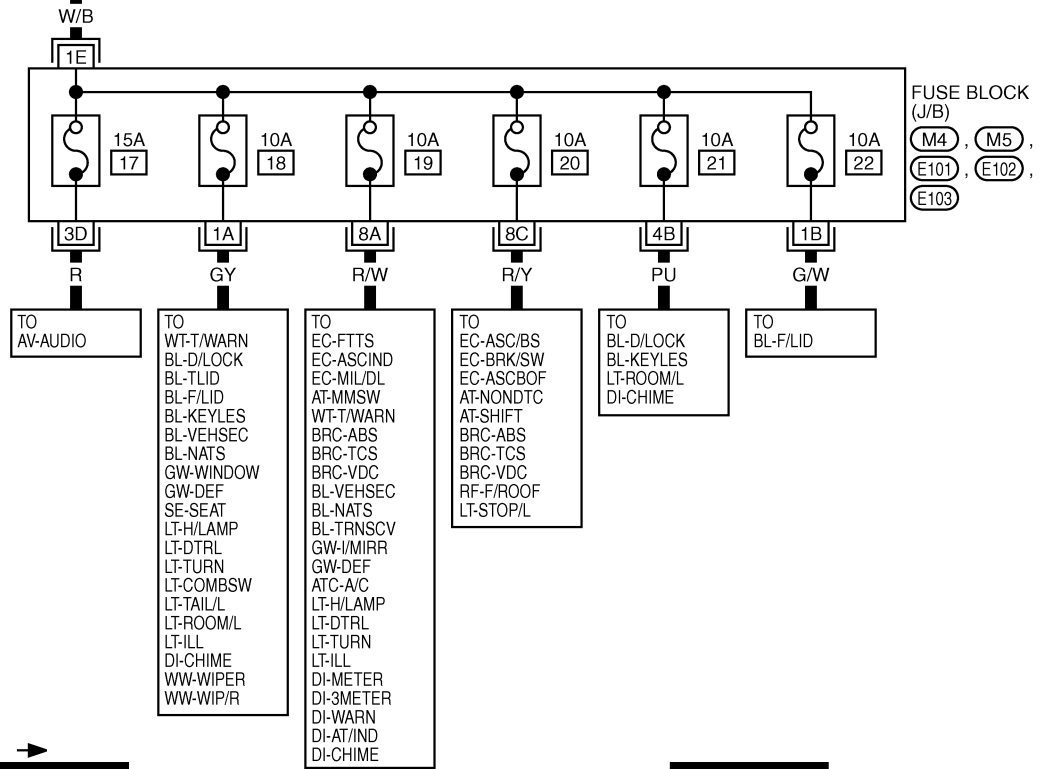
PRECEDING PAGE  B W/B



PRECEDING PAGE  C R

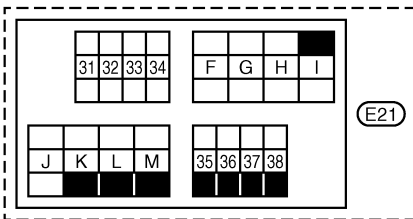
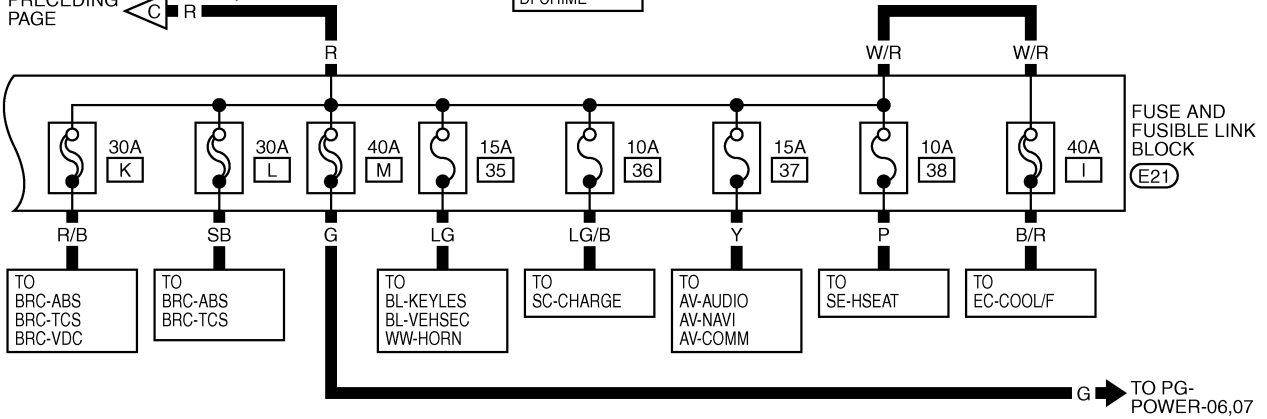

REFER TO THE FOLLOWING.

(M4), (M5), (E101), (E102),
(E103) - FUSE BLOCK-JUNCTION BOX (J/B)

1	2	3	4	5	6	7	8	9	10	11
12	13	14	15	16	17	18	19	20	21	22

TKWT4103E

POWER SUPPLY ROUTING CIRCUIT

PG-POWER-03

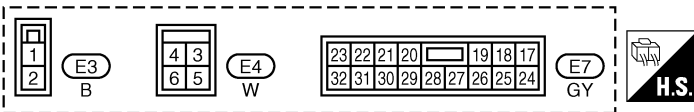
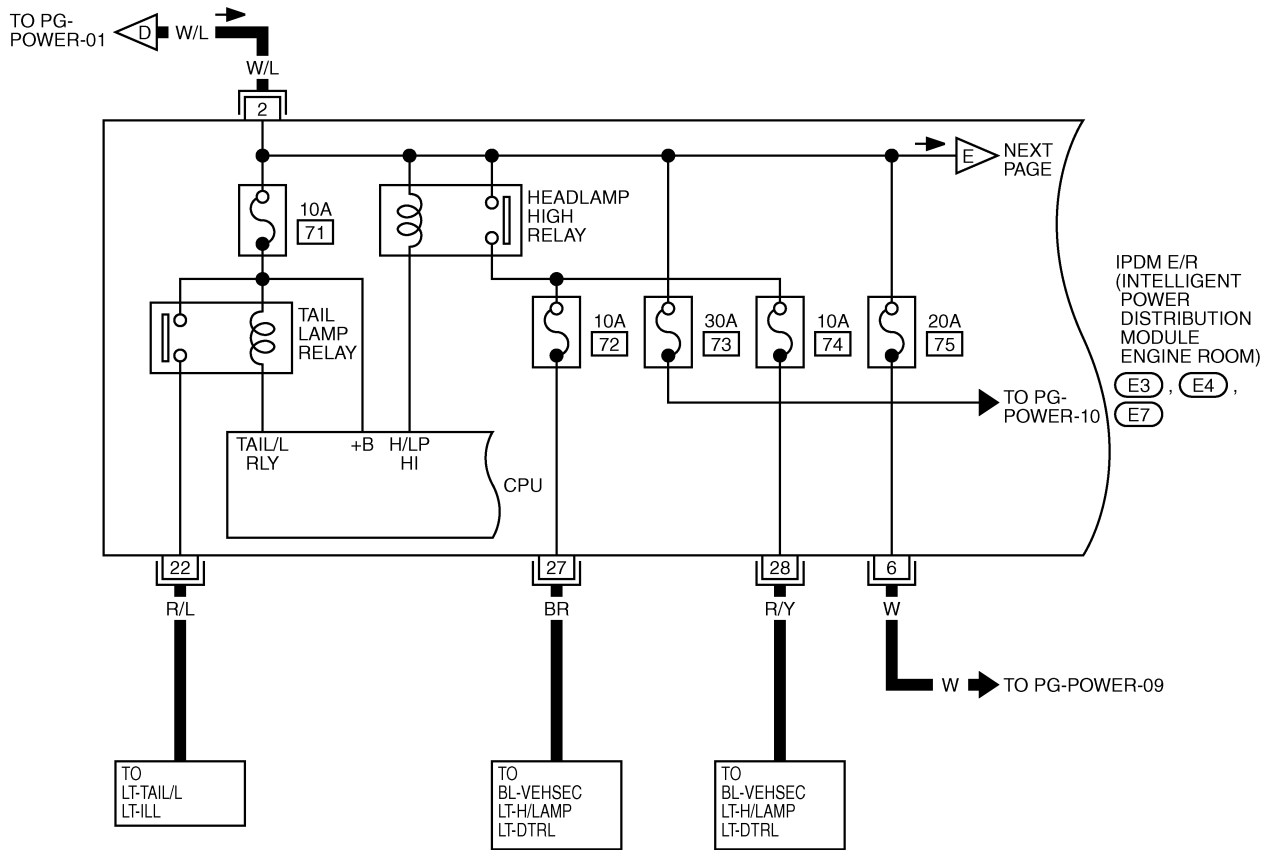

TKWT5637E

POWER SUPPLY ROUTING CIRCUIT

PG-POWER-04

A
B
C
D
E
F
G
H
I
J
L
M

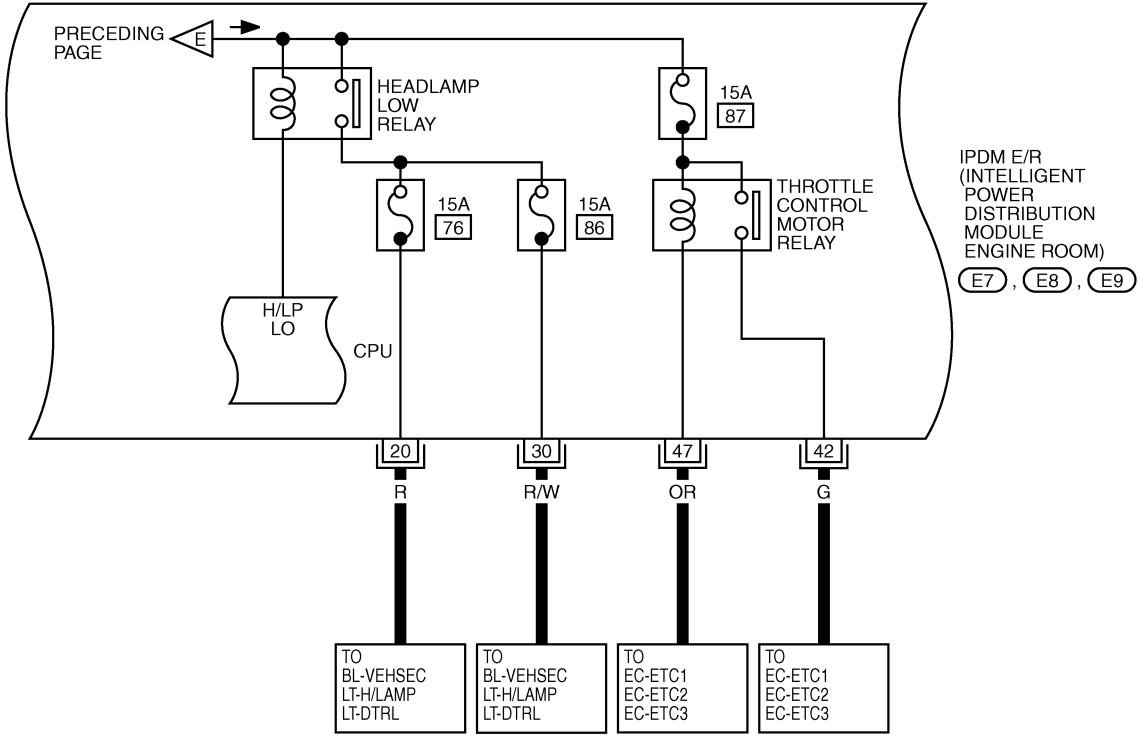

PG

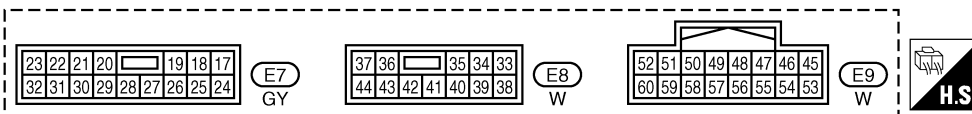

TKWT4105E

POWER SUPPLY ROUTING CIRCUIT

PG-POWER-05

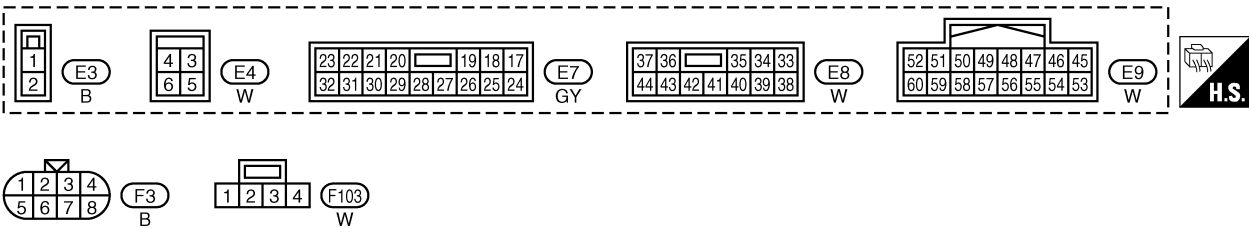
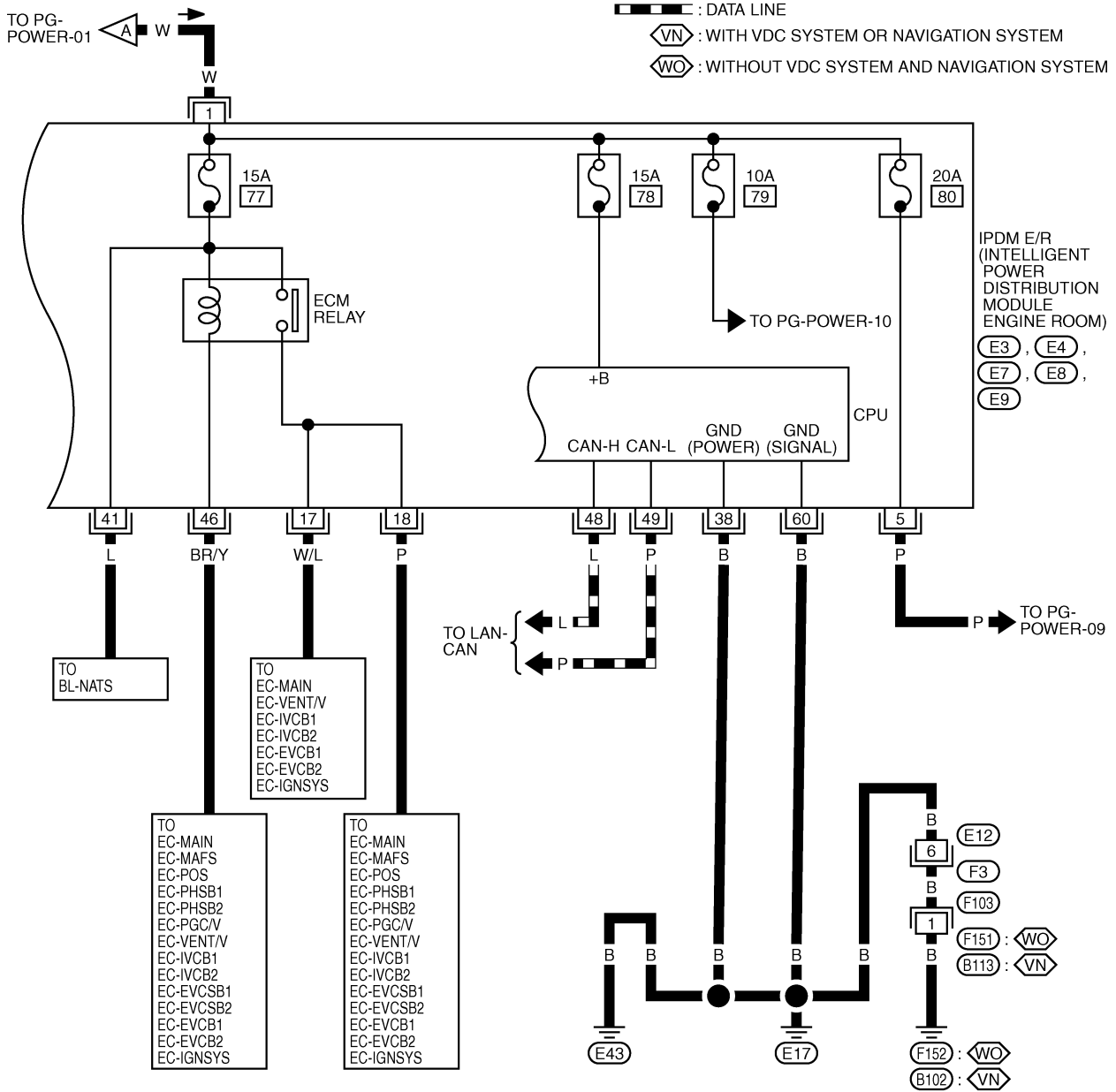

TKWT5638E

POWER SUPPLY ROUTING CIRCUIT

ACCESSORY POWER SUPPLY — IGNITION SW. IN “ACC” OR “ON”

PG-POWER-06

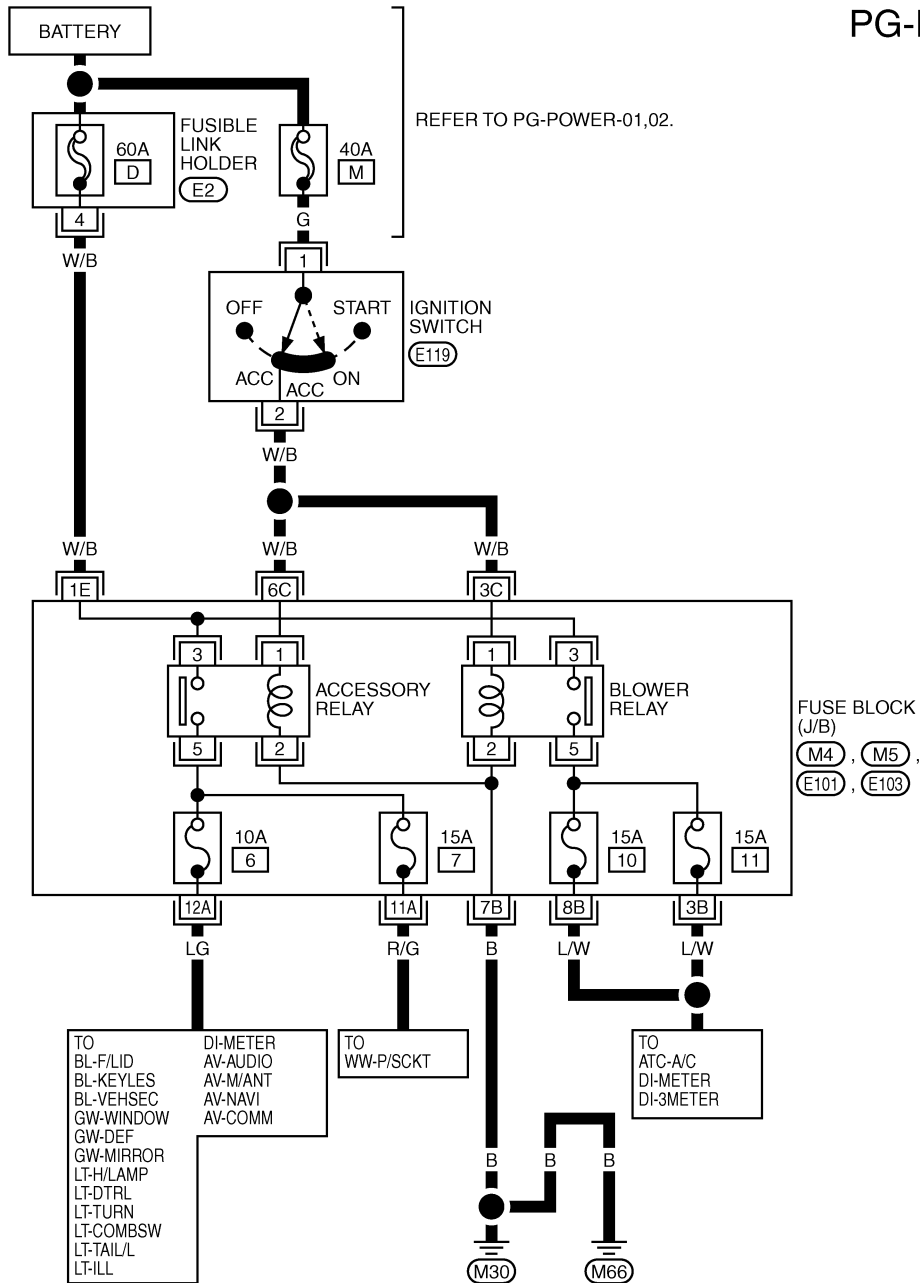

FUSE BLOCK (J/B)
 (M4), (M5),
 (E101), (E103)

- TO BL-F/LID
- TO BL-KEYLES
- TO BL-VEHSEC
- TO GW-WINDOW
- TO GW-DEF
- TO GW-MIRROR
- TO LT-H/LAMP
- TO LT-DTRL
- TO LT-TURN
- TO LT-COMBSW
- TO LT-TAIL/L
- TO LT-ILL
- DI-METER AV-AUDIO
- DI-METER AV-M/ANT
- DI-METER AV-NAVI
- DI-METER AV-COMM
- TO WW-P/SCKT
- TO ATC-AC
- DI-METER
- DI-3METER

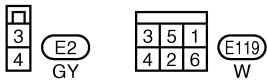

REFER TO THE FOLLOWING.

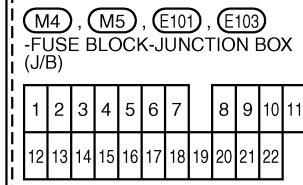

TKWT4107E

POWER SUPPLY ROUTING CIRCUIT

IGNITION POWER SUPPLY — IGNITION SW. IN “ON” AND/OR “START”

PG-POWER-07

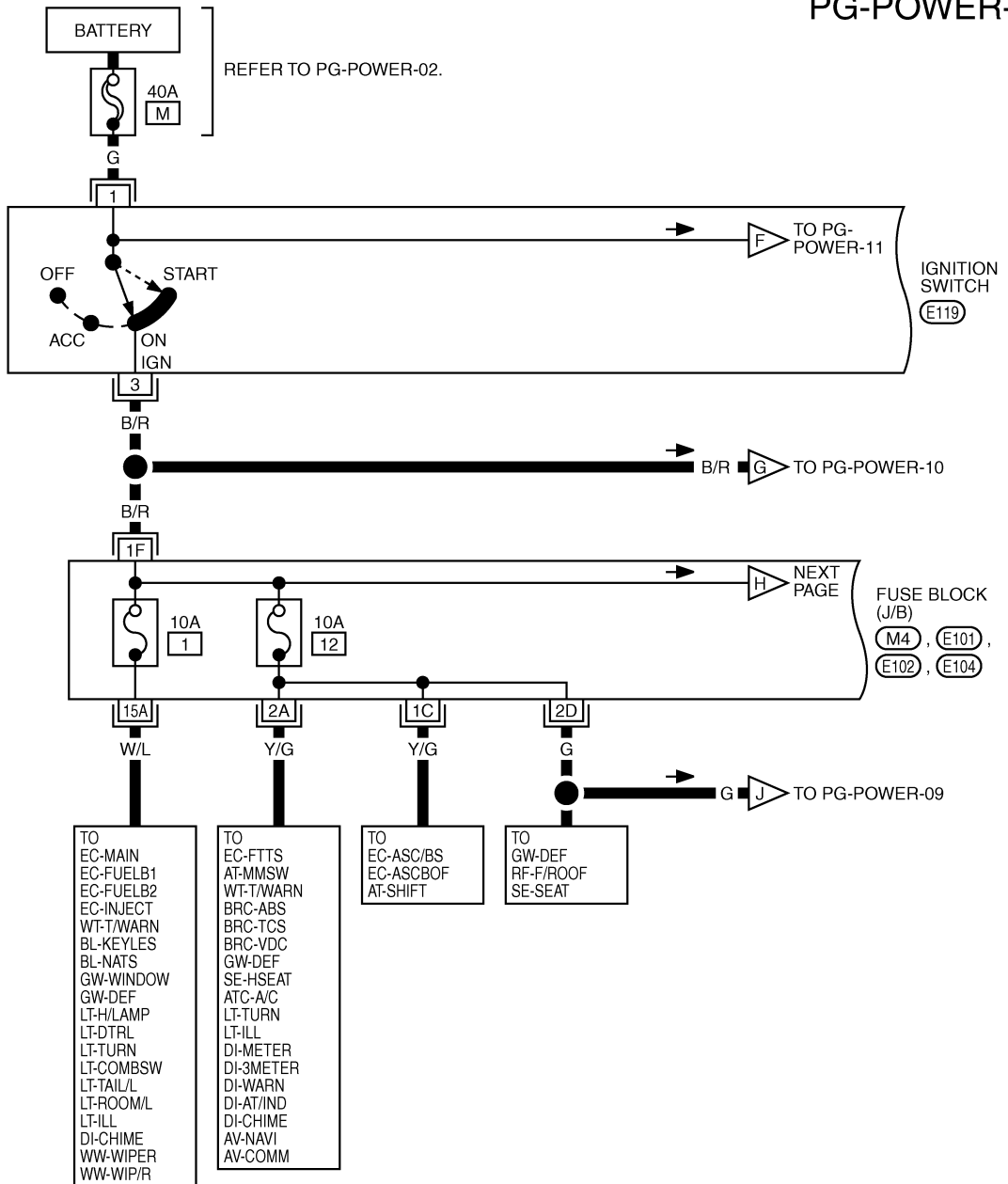

3	5	1
4	2	6

(E119)
W

REFER TO THE FOLLOWING

(M4), (E101), (E102), (E104)
- FUSE BLOCK-JUNCTION BOX (J/B)

1	2	3	4	5	6	7	8	9	10	11
12	13	14	15	16	17	18	19	20	21	22

TKWT5639E

POWER SUPPLY ROUTING CIRCUIT

PG-POWER-08

A
B
C
D
E
F
G
H
I
J
L
M

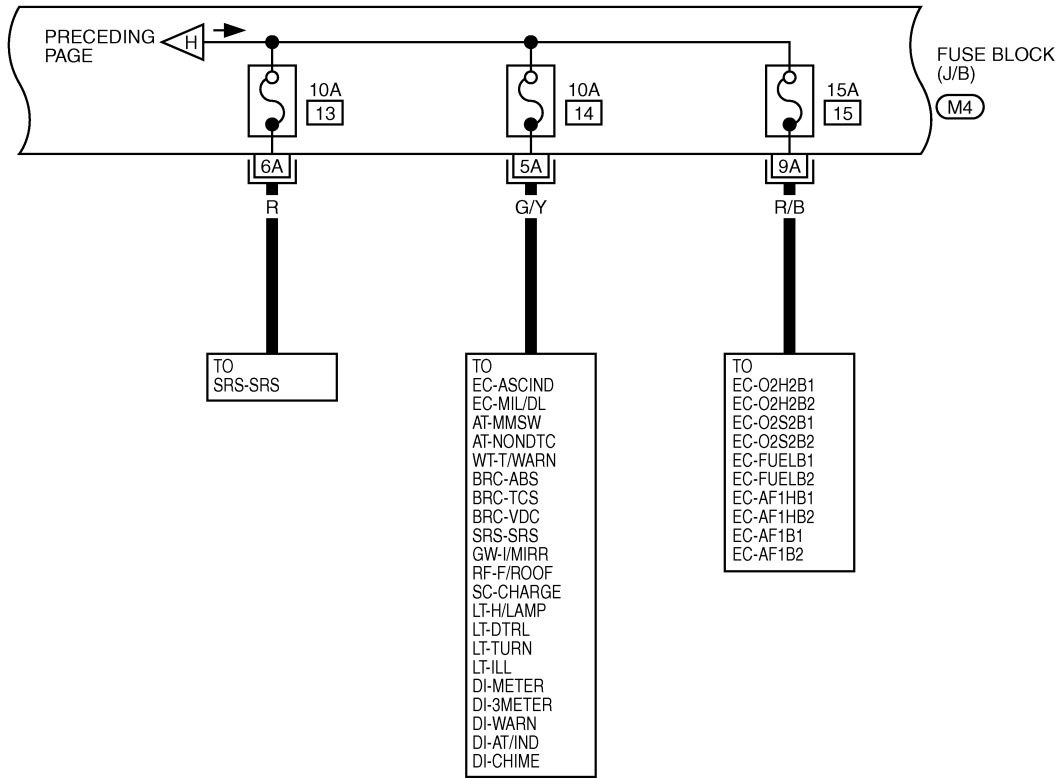

PG

REFER TO THE FOLLOWING.

(M4) - FUSE BLOCK-
JUNCTION BOX (J/B)

1	2	3	4	5	6	7	8	9	10	11
12	13	14	15	16	17	18	19	20	21	22

TKWM1379E

POWER SUPPLY ROUTING CIRCUIT

PG-POWER-10

A
B
C
D
E
F
G
H
I
J
K
L
M

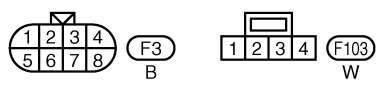
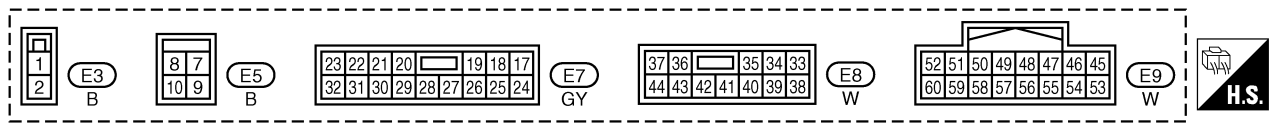
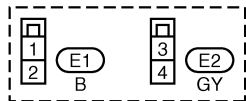
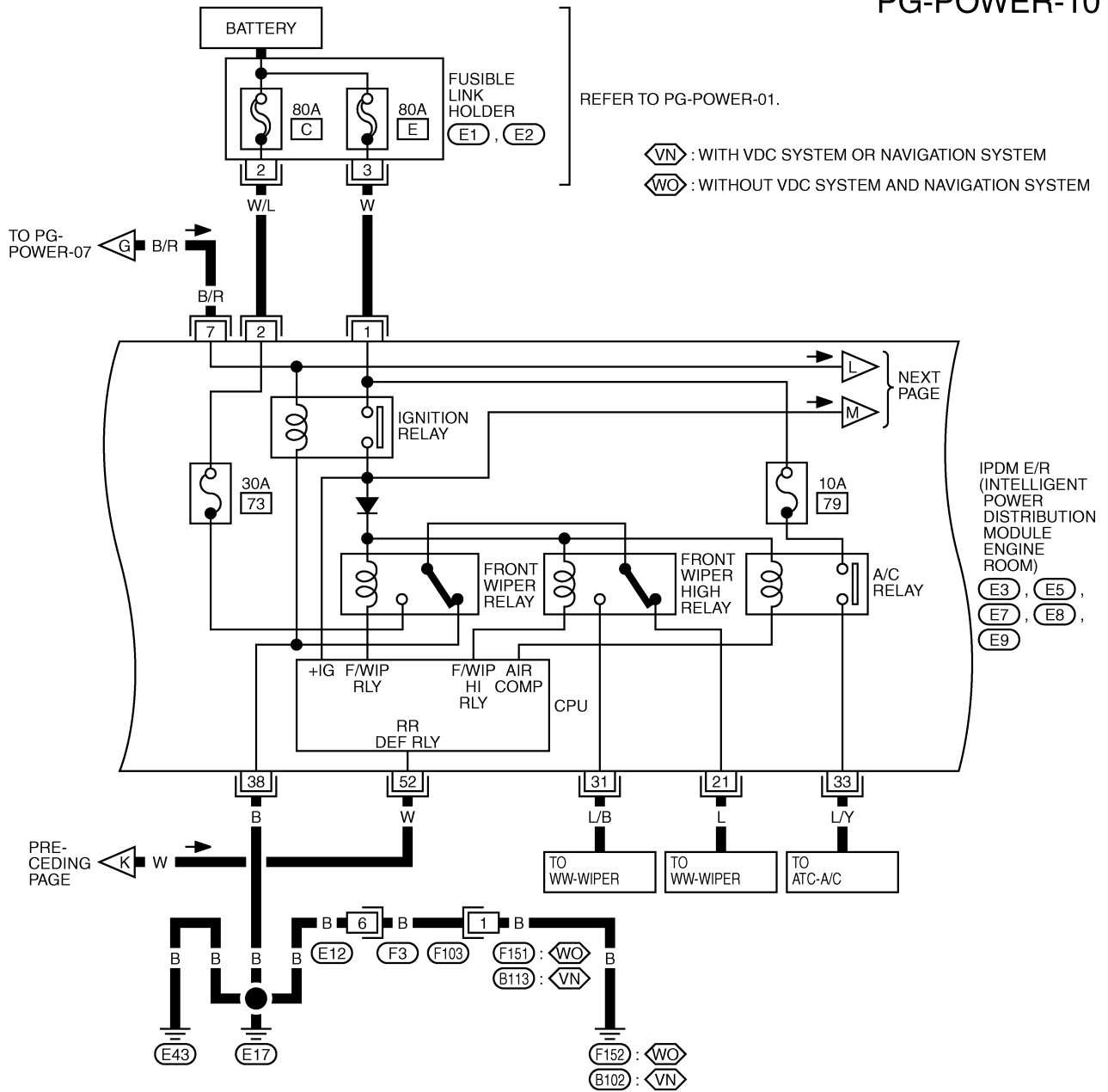

TKWT5640E

POWER SUPPLY ROUTING CIRCUIT

PG-POWER-11

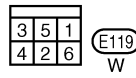
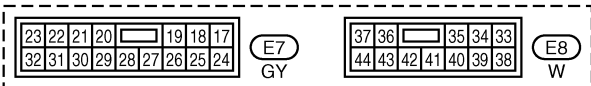
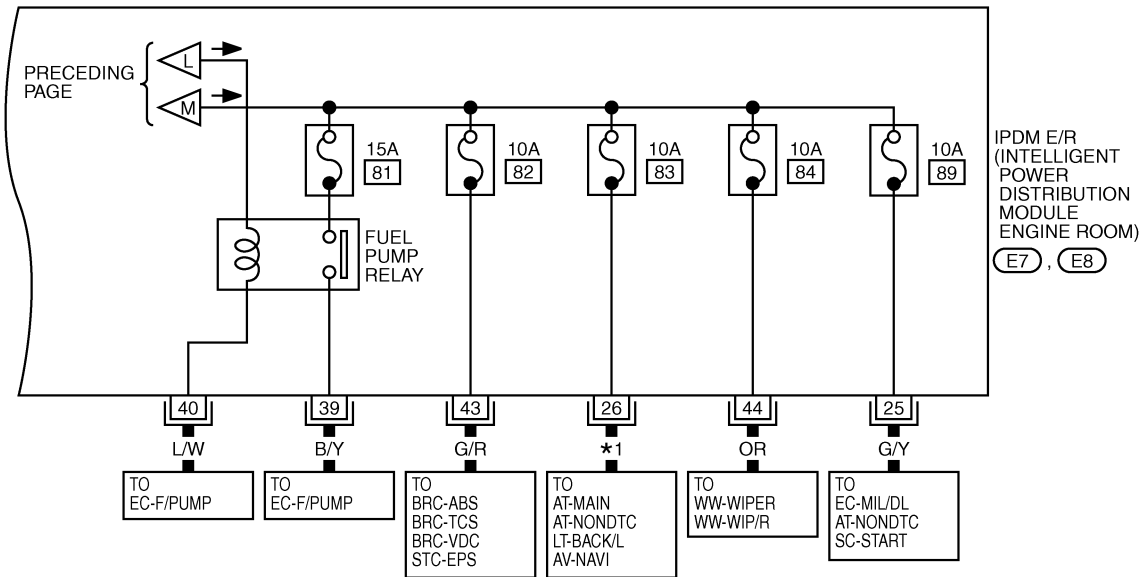
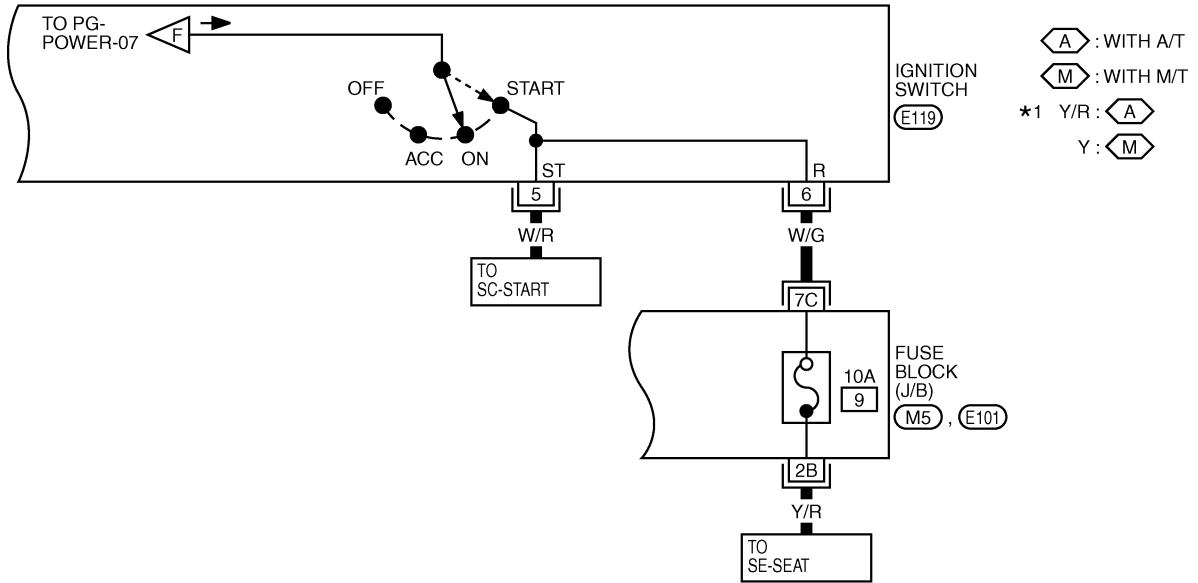

REFER TO THE FOLLOWING.

(M5, E101) - FUSE BLOCK-JUNCTION BOX (J/B)

1	2	3	4	5	6	7	8	9	10	11
12	13	14	15	16	17	18	19	20	21	22

TKWT4111E

POWER SUPPLY ROUTING CIRCUIT

Fuse

- If fuse is blown, be sure to eliminate cause of malfunction before installing new fuse.
- Use fuse of specified rating. Never use fuse of more than specified rating.
- Do not partially install fuse; always insert it into fuse holder properly.
- Remove fuse for "ELECTRICAL PARTS (BAT)" if vehicle is not used for a long period of time.

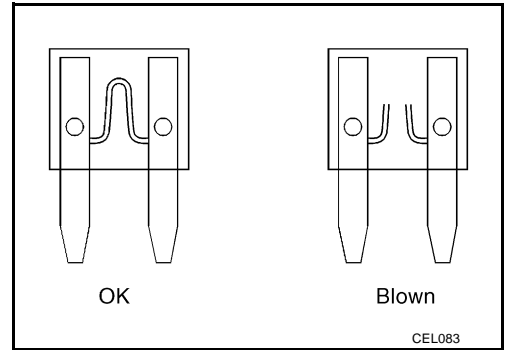

Fusible Link

A melted fusible link can be detected either by visual inspection or by feeling with finger tip. If its condition is questionable, use circuit tester or test lamp.

CAUTION:

- If fusible link should melt, it is possible that critical circuit (power supply or large current carrying circuit) is shorted. In such a case, carefully check and eliminate cause of malfunction.
- Never wrap outside of fusible link with vinyl tape. Important: Never let fusible link touch any other wiring harness, vinyl or rubber parts.

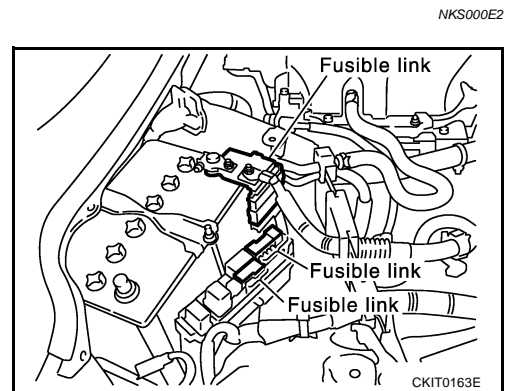

Circuit Breaker

The PTC thermistor generates heat in response to current flow. The temperature (and resistance) of the thermistor element varies with current flow. Excessive current flow will cause the element's temperature to rise. When the temperature reaches a specified level, the electrical resistance will rise sharply to control the circuit current. Reduced current flow will cause the element to cool. Resistance falls accordingly and normal circuit current flow is allowed to resume.

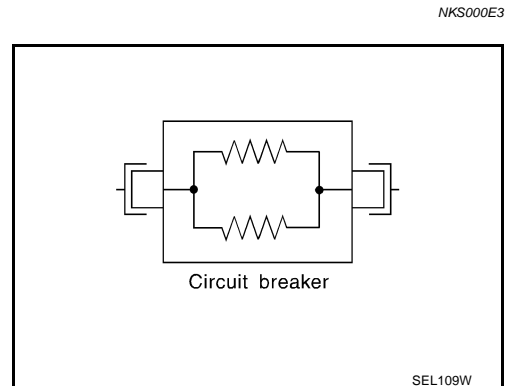

A
B
C
D
E
F
G
H
I
J
PG
L
M

IPDM E/R (INTELLIGENT POWER DISTRIBUTION MODULE ENGINE ROOM)

IPDM E/R (INTELLIGENT POWER DISTRIBUTION MODULE ENGINE ROOM)

PFP:284B7

System Description

NKS000E4

- IPDM E/R (Intelligent Power Distribution Module Engine Room) integrates relays and fuse blocks which were originally placed in engine room. It controls integrated relays via IPDM E/R control circuit.
- IPDM E/R integrated control unit performs ON-OFF operation of relay, hood switch signal reception, etc.
- It controls operation of each electrical part via ECM, BCM and CAN communication lines.

CAUTION:

None of the IPDM E/R-integrated relays can be removed.

SYSTEMS CONTROLLED BY IPDM E/R

IPDM E/R receives a request signal from each control unit with CAN communication. It controls each system.

Control system	Transmit control unit	Control part
Lamp control	BCM	<ul style="list-style-type: none">● Head lamps (HI, LO)● Parking lamps, license plate lamps and tail lamps
Wiper control	BCM	Front wipers
Rear window defogger control	BCM	Rear window defogger
A/C compressor control	ECM	A/C compressor (magnet clutch)
Cooling fan control	ECM	Cooling fan

CAN COMMUNICATION LINE CONTROL

With CAN communication, by connecting each control unit using two communication lines (CAN L line, CAN H line), it is possible to transmit maximum amount of information with minimum wiring. Each control unit can transmit and receive data, and reads necessary information only.

1. Fail-safe control

- When CAN communication with other control units is impossible, IPDM E/R performs fail-safe control. After CAN communication recovers normally, it also returns to normal control.
- Operation of control parts by IPDM E/R during fail-safe mode is as follows:

Controlled system	Fail-safe mode
Headlamp	<ul style="list-style-type: none">● With the ignition switch ON, the headlamp (low) is ON.● With the ignition switch OFF, the headlamp (low) is OFF.
Parking, license plate and tail lamps	<ul style="list-style-type: none">● With the ignition switch ON, the parking, license plate and tail lamps are ON.● With the ignition switch OFF, the parking, license plate and tail lamps are OFF.
Cooling fan	<ul style="list-style-type: none">● With the ignition switch ON, the cooling fan HI operates.● With the ignition switch OFF, the cooling fan stops.
Front wiper	Until the ignition switch is turned OFF, the front wiper LO and HI remains in the same status it was in just before fail-safe control was initiated.
Rear window defogger	Rear window defogger relay OFF
A/C compressor	A/C compressor OFF

IPDM E/R (INTELLIGENT POWER DISTRIBUTION MODULE ENGINE ROOM)

IPDM E/R STATUS CONTROL

In order to save power, IPDM E/R switches status by itself based on each operating condition.

1. CAN communication status
 - CAN communication is normally performed with other control units.
 - Individual unit control by IPDM E/R is normally performed.
 - When sleep request signal is received from BCM, mode is switched to sleep waiting status.
2. Sleep waiting status
 - Process to stop CAN communication is activated.
 - All systems controlled by IPDM E/R are stopped. When 3 seconds have elapsed after CAN communication with other control units is stopped, mode switches to sleep status.
3. Sleep status
 - IPDM E/R operates in low power mode.
 - CAN communication is stopped.
 - When a change in CAN communication line is detected, mode switches to CAN communication status.
 - When a change in hood switch or ignition switch signal is detected, mode switches to CAN communication status.

CAN Communication System Description

NKS000E5

CAN (Controller Area Network) is a serial communication line for real time application. It is an on-vehicle multiplex communication line with high data communication speed and excellent error detection ability. Modern vehicles are equipped with many electronic control units and each control unit shares information and links with other control units during operation (not independent). In CAN communication, control units are connected with 2 communication lines (CAN H line, CAN L line) allowing a high rate of information transmission with less wiring. Each control unit transmits/receives data but selectively reads required data only.

CAN Communication Unit

NKS000E6

Refer to [LAN-48, "CAN System Specification Chart"](#).

Function of Detecting Ignition Relay Malfunction

NKS000E7

- When contact point of integrated ignition relay is stuck and cannot be turned OFF, IPDM E/R turns ON parking lamp, license plate lamp and tail lamp for 10 minutes to indicate ignition relay malfunction.
- When a state of ignition relay having built-in does not agree with a state of Ignition switch signal input by a CAN communication from BCM, IPDM E/R lets tail lamp relay operate.

Ignition switch signal	Ignition relay status	Tail lamp relay and daytime light relay ^{*1}
ON	ON	—
OFF	OFF	—
ON	OFF	—
OFF	ON	ON (10 minutes)

NOTE:

- When the ignition switch is turned ON, tail lamp relay and daytime light relay are OFF.
- *1: Canada model only

IPDM E/R (INTELLIGENT POWER DISTRIBUTION MODULE ENGINE ROOM)

CONSULT-II Function (IPDM E/R)

NKS000E8

CONSULT-II can display each diagnostic item using the diagnostic test modes shown following.

Inspection Item, Diagnosis Mode	Description
SELF-DIAG RESULTS	The IPDM E/R performs diagnosis of the CAN communication and self-diagnosis.
DATA MONITOR	The input/output data of the IPDM E/R is displayed in real time.
CAN DIAG SUPPORT MNTR	The result of transmit/receive diagnosis of CAN communication can be read.
ACTIVE TEST	The IPDM E/R sends a drive signal to electronic components to check their operation.

CONSULT-II BASIC OPERATION

Refer to [GI-36, "CONSULT-II Start Procedure"](#).

SELF-DIAG RESULTS

Operation Procedure

1. Touch "SELF-DIAG RESULTS" on "SELECT DIAG MODE" screen.
2. Check display content in self-diagnosis results.

Display Item List

Display Items	CONSULT-II display code	Malfunction detecting condition	TIME		Possible causes
			CRNT	PAST	
NO DTC IS DETECTED.FURTHER TESTING MAY BE REQUIRED.	-	-	-	-	-
CAN COMM CIRC	U1000	<ul style="list-style-type: none"> ● If CAN communication reception/transmission data has a malfunction, or if any of the control units malfunction, data reception/transmission cannot be confirmed. ● When the data in CAN communication is not received before the specified time 	×	×	Any of or several items below have errors. <ul style="list-style-type: none"> ● TRANSMIT DIAG ● ECM ● BCM

NOTE:

The details for display of the period are as follows:

- CRNT: Error currently detected with IPDM E/R.
- PAST: Error detected in the past and memorized with IPDM E/R.

IPDM E/R (INTELLIGENT POWER DISTRIBUTION MODULE ENGINE ROOM)

DATA MONITOR

Operation Procedure

1. Touch "DATA MONITOR" on "SELECT DIAG MODE" screen.
2. Touch "ALL SIGNALS", "MAIN SIGNALS" or "SELECTION FROM MENU" on the "SELECT MONITOR ITEM" screen.

ALL SIGNALS	All items will be monitored.
MAIN SIGNALS	Monitor the predetermined item.
SELECTION FROM MENU	Select any item for monitoring.

3. Touch the required monitoring item on "SELECTION FROM MENU". In "ALL SIGNALS", all items are monitored. In "MAIN SIGNALS", predetermined items are monitored.
4. Touch "START".
5. Touch "RECORD" while monitoring to record the status of the item being monitored. To stop recording, touch "STOP".

All Items, Main Items, Selection From Menu

Item name	CONSULT-II screen display	Display or unit	SELECT MONITOR ITEM			Description
			ALL SIGNALS	MAIN SIGNALS	SELECTION FROM MENU	
Motor fan request	MOTOR FAN REQ	1/2/3/4	×	×	×	Signal status input from ECM
Compressor request	AC COMP REQ	ON/OFF	×	×	×	Signal status input from ECM
Parking request	TAIL&CLR REQ	ON/OFF	×	×	×	Signal status input from BCM
H/L LO request	HL LO REQ	ON/OFF	×	×	×	Signal status input from BCM
H/L HI request	HL HI REQ	ON/OFF	×	×	×	Signal status input from BCM
Front fog request	FR FOG REQ ^{*1}	ON/OFF	×	×	×	—
Head lamp washer request	HL WASHER REQ ^{*1}	ON/OFF	×		×	—
Front wiper request	FR WIP REQ	STOP/1LOW/LOW/HI	×	×	×	Signal status input from BCM
Wiper auto stop	WIP AUTO STOP	ACT P/STOP P	×	×	×	Output status of IPDM E/R
Wiper protection	WIP PROT	OFF/Block	×	×	×	Control status of IPDM E/R
Starter request	ST RLY REQ ^{*2}	ON/OFF	×		×	Status of input signal
Ignition relay status	IGN RLY	ON/OFF	×	×	×	Ignition relay status monitored with IPDM E/R
Rear window defogger request	RR DEF REQ	ON/OFF	×	×	×	Signal status input from BCM
Oil pressure switch	OIL P SW ^{*1}	OPEN/CLOSE	×		×	—
Day time light request	DTRL REQ ^{*3}	ON/OFF	×		×	Signal status input from BCM
Hood switch	HOOD SW ^{*1}	ON/OFF	×		×	—
Theft warning horn request	THFT HRN REQ	ON/OFF	×		×	Signal status input from BCM
Horn chirp	HORN CHIRP	ON/OFF	×		×	Output status of IPDM E/R

NOTE:

- Perform monitoring of IPDM E/R data with the ignition switch ON. When the ignition switch is at ACC, the display may not be correct.
- *1: This items is displayed, but does not function.
- *2: The vehicle without intelligent key system displays only ON without change.
- *3: Only the vehicle with daytime light system operates.

IPDM E/R (INTELLIGENT POWER DISTRIBUTION MODULE ENGINE ROOM)

ACTIVE TEST

Operation Procedure

1. Touch "ACTIVE TEST" on "SELECT DIAG MODE" screen.
2. Touch item to be tested.
3. Touch "START", and confirm its operation.
4. Touch "STOP" while testing to stop the operation.

Test item	CONSULT-II screen display	Description
Tail lamp operation	TAIL LAMP	With a certain ON-OFF operation, the tail lamp relay can be operated.
Rear window defogger operation	REAR DEFOGGER	With a certain ON-OFF operation, the rear window defogger relay can be operated.
Front wiper (HI, LO) operation	FRONT WIPER	With a certain operation (OFF, HI ON, LO ON), the front wiper relay (Lo, Hi) can be operated.
Cooling fan operation	MOTOR FAN	With a certain operation (1,2,3,4), the cooling fan can be operated.
Headlamp washer ^{NOTE 1}	HEAD LAMP WASHER	—
Lamp (HI, LO, FOG ^{NOTE 2}) operation	LAMPS	With a certain operation (OFF, HI ON, LO ON, FOG ON ^{NOTE}), the lamp relay (Lo, Hi, Fog ^{NOTE}) can be operated.
Horn operation	HORN	Push "ON" button, horn relay operates 20 ms.

NOTE:

1. Headlamp washer item is displayed, but it cannot be tested.
2. Fog lamp item is displayed, but it cannot be tested.

Auto Active Test

DESCRIPTION

In auto active test mode, operation inspection can be performed when IPDM E/R sends a drive signal to the following systems:

- Rear window defogger
- Front wipers
- Parking lamp, license plate lamp and tail lamp
- Headlamps (Hi, Lo)
- A/C compressor (magnetic clutch)
- Cooling fan

OPERATION PROCEDURE

1. Close hood and front door (passenger side), and then lift wiper arms away from windshield (to prevent glass damage by wiper operation).

NOTE:

When auto active test is performed with hood opened, sprinkle water on windshield beforehand.

2. Turn ignition switch OFF.
3. Turn ignition switch ON, and, within 20 seconds, press driver's front door switch 10 times (close other door). Then turn ignition switch OFF.
4. Turn ignition switch ON within 10 seconds after ignition switch OFF.
5. When auto active test mode is actuated, horn chirps once. Oil pressure warning lamp starts blinking.
6. After a series of operations is repeated three times, auto active test is completed.

NOTE:

When auto active test mode has to be cancelled halfway, turn ignition switch OFF.

CAUTION:

Be sure to inspect **BL-38, "Check Door Switch"** when the auto active test cannot be performed.

INSPECTION IN AUTO ACTIVE TEST MODE

When auto active test mode is actuated, the following eight steps are repeated three times.

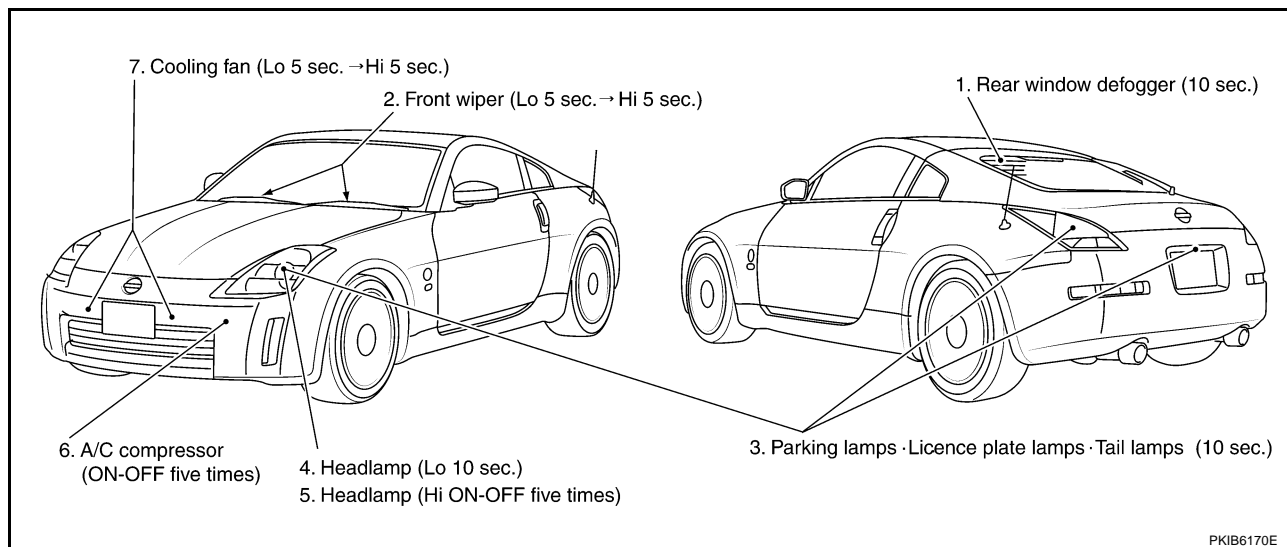

NOTE:

It takes 10 seconds from 3 to 4.

IPDM E/R (INTELLIGENT POWER DISTRIBUTION MODULE ENGINE ROOM)

Concept of Auto Active Test

- IPDM E/R actuates auto active test mode when it receives door switch signal from BCM via CAN communication line. Therefore, when auto active test mode is activated successfully, CAN communication between IPDM E/R and BCM is normal.
- If any of systems controlled by IPDM E/R cannot be operated, possible cause can be easily diagnosed using auto active test.

Diagnosis chart in auto active test mode

Symptom	Inspection contents	Possible cause	
Rear window defogger does not operate.	Perform auto active test. Does rear window defogger operate?	YES	● BCM signal input circuit
		NO	<ul style="list-style-type: none"> ● Rear window defogger relay circuit ● Open circuit of rear window defogger ● IPDM E/R malfunction
Any of front wipers, tail and parking lamps, front fog lamps, and head lamps (Hi, Lo) do not operate.	Perform auto active test. Does system in question operate?	YES	● BCM signal input system
		NO	<ul style="list-style-type: none"> ● Lamp/wiper motor malfunction ● Lamp/wiper motor ground circuit malfunction ● Harness/connector malfunction between IPDM E/R and system in question ● IPDM E/R (integrated relay) malfunction
A/C compressor does not operate.	Perform auto active test. Does magnetic clutch operate?	YES	<ul style="list-style-type: none"> ● BCM signal input circuit ● CAN communication signal between BCM and ECM. ● CAN communication signal between ECM and IPDM E/R
		NO	<ul style="list-style-type: none"> ● Magnetic clutch malfunction ● Harness/connector malfunction between IPDM E/R and magnetic clutch ● IPDM E/R (integrated relay) malfunction
Cooling fan does not operate.	Perform auto active test. Does cooling fan operate?	YES	<ul style="list-style-type: none"> ● ECM signal input circuit ● CAN communication signal between ECM and IPDM E/R
		NO	<ul style="list-style-type: none"> ● Cooling fan motor malfunction ● Harness/connector malfunction between IPDM E/R and cooling fan motor ● IPDM E/R (integrated relay) malfunction

IPDM E/R (INTELLIGENT POWER DISTRIBUTION MODULE ENGINE ROOM)

Schematic/Type 1

NKS000EA

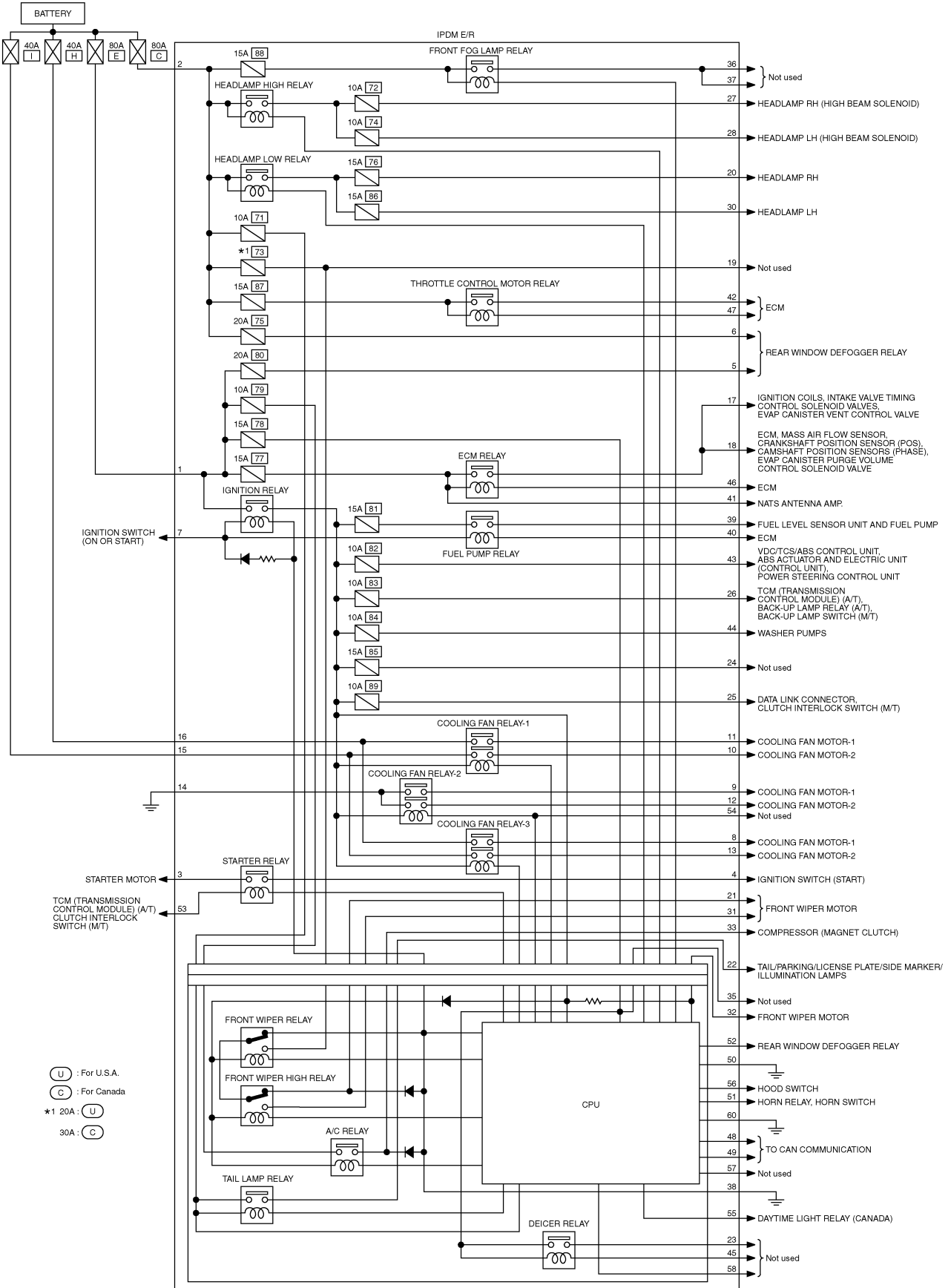

TKWT4112E

IPDM E/R (INTELLIGENT POWER DISTRIBUTION MODULE ENGINE ROOM)

Schematic/Type 2

NKS0054B

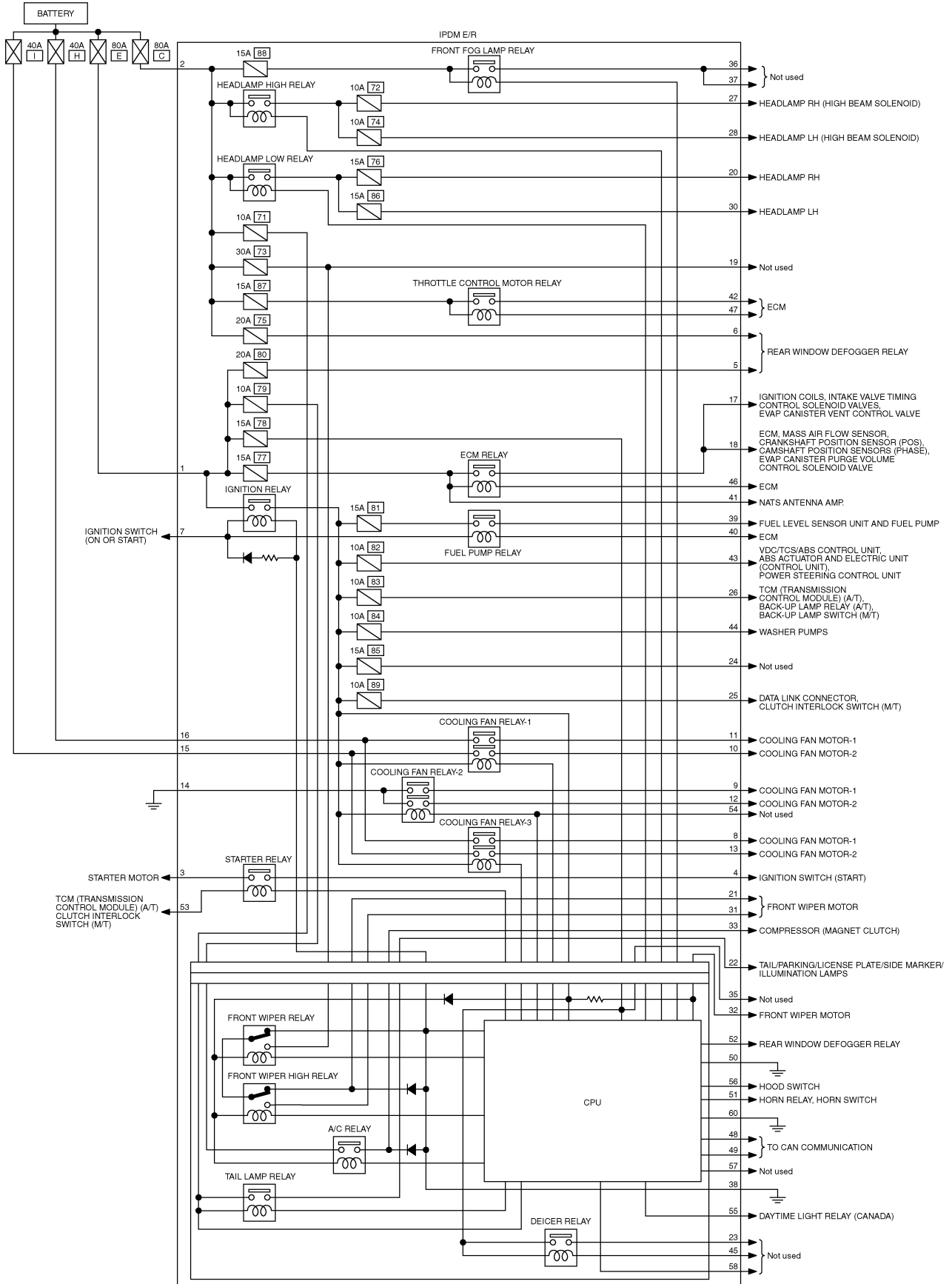

TKWT5641E

IPDM E/R (INTELLIGENT POWER DISTRIBUTION MODULE ENGINE ROOM)

IPDM E/R Terminal Arrangement/Type 1

NKS000EB

A
B
C
D
E
F
G
H
I
J
PG
L
M

- *1 20A: U.S.A.
30A: Canada
- *2 Not mounted: U.S.A.
15A: Canada

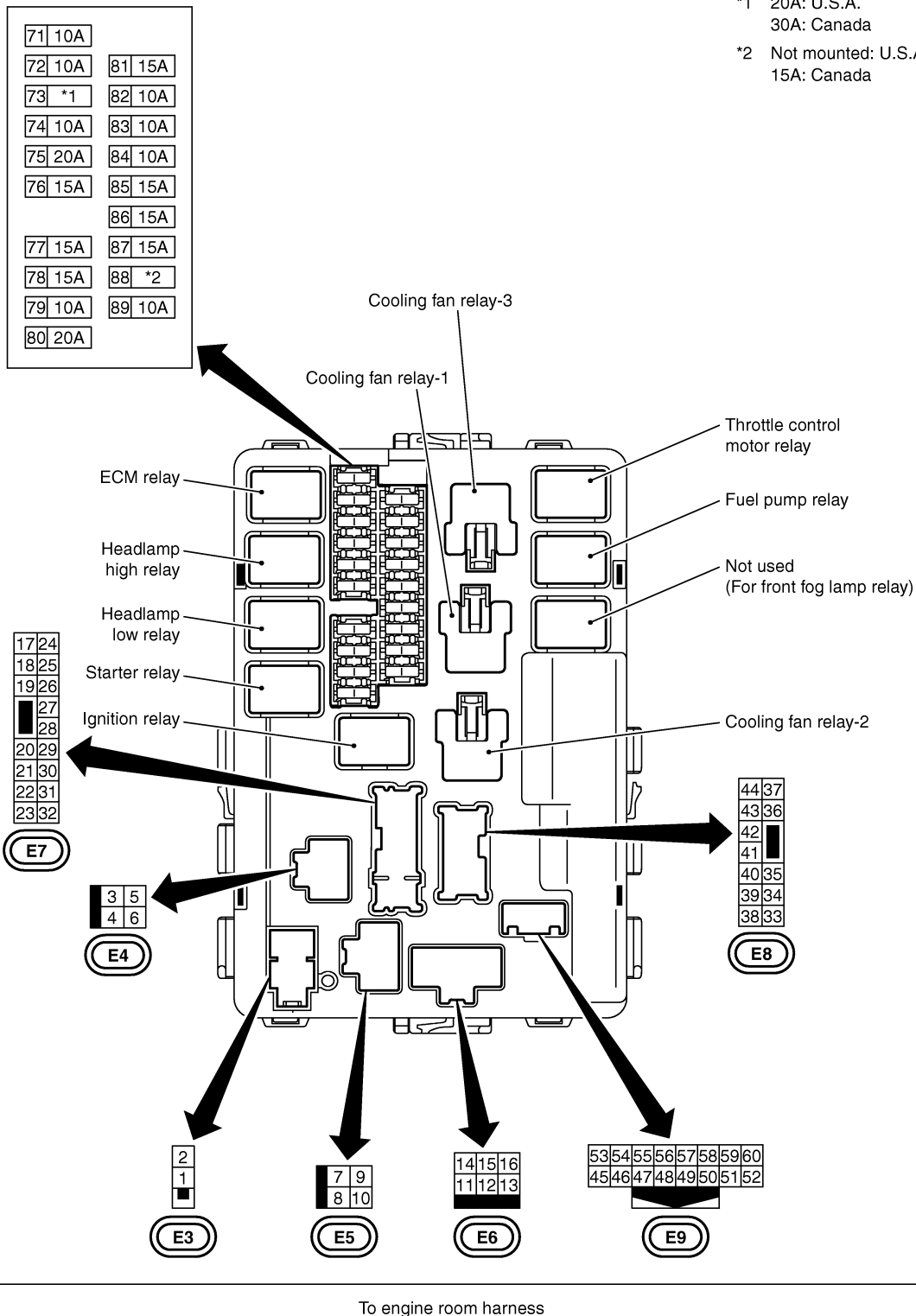

CKIT0727E

IPDM E/R Terminal Arrangement/Type 2

NKS0054C

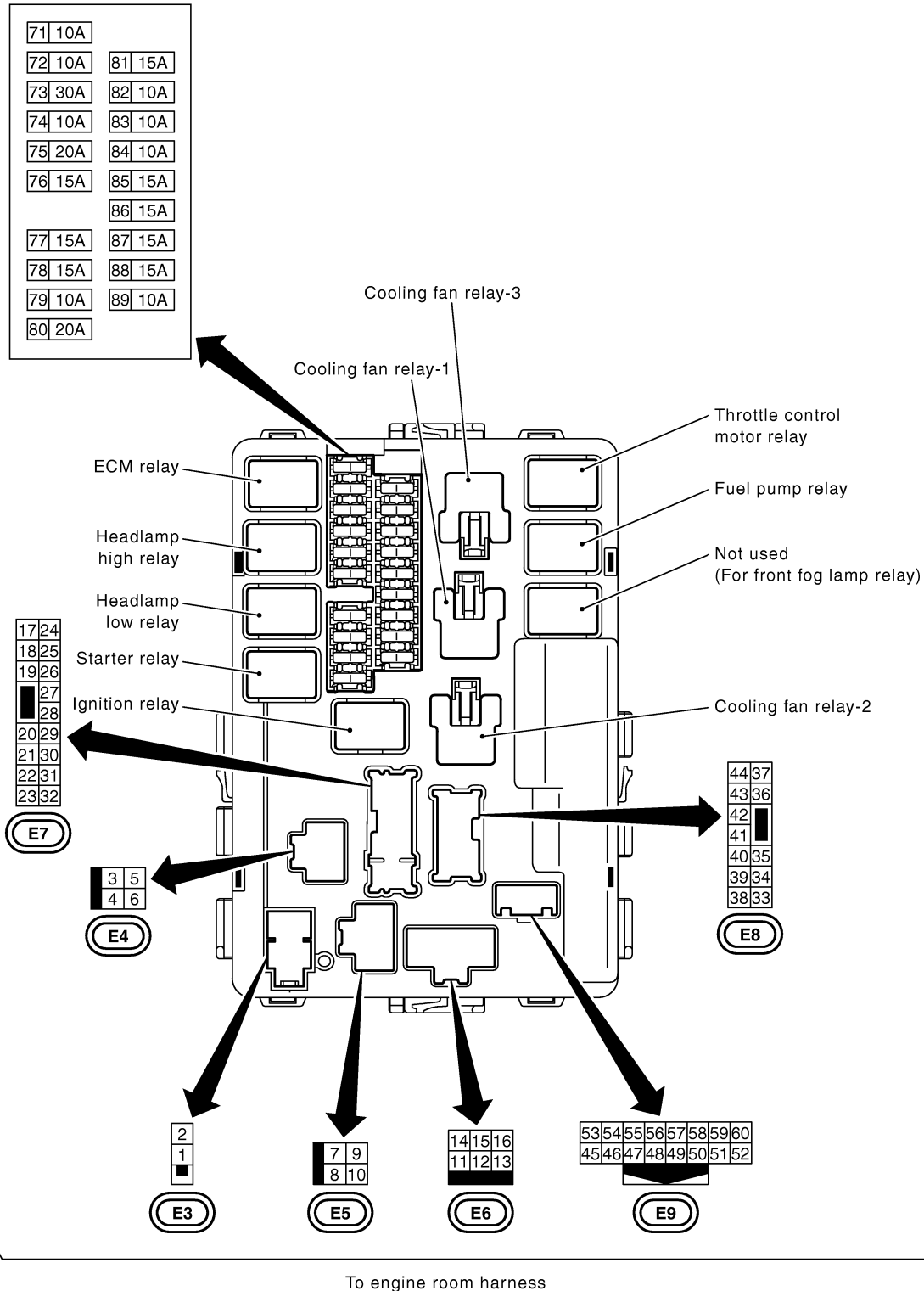

CKIT0850E

IPDM E/R (INTELLIGENT POWER DISTRIBUTION MODULE ENGINE ROOM)

IPDM E/R Power/Ground Circuit Inspection

NKS000EC

1. CHECK FUSE AND FUSIBLE LINK

Make sure the following fusible links or IPDM E/R fuses are not blown.

Terminal No.	Signal name	Fuse and fusible link No.
1	Battery power	E
2		C
—		71
—		78

OK or NG

OK >> GO TO 2.

NG >> If fuse or fusible link is blown, be sure to eliminate cause of malfunction before installing new fuse or fusible link.

2. CHECK POWER SUPPLY CIRCUIT

1. Turn ignition switch OFF.
2. Disconnect IPDM E/R harness connector.
3. Check voltage between IPDM E/R harness connector and ground.

Terminal		(-)	Voltage (Approx.)
(+)	Terminal		
IPDM E/R connector	1	Ground	Battery voltage
	2		

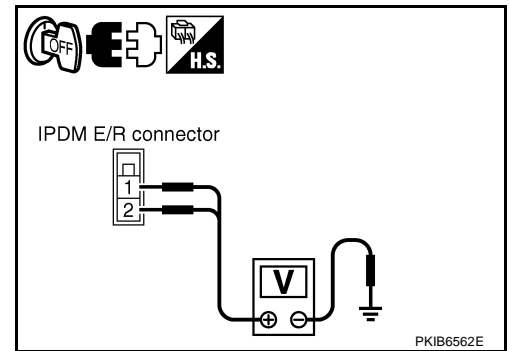

OK or NG

OK >> GO TO 3.

NG >> Repair harness or connector.

3. CHECK GROUND CIRCUIT

1. Disconnect IPDM E/R harness connectors.
2. Check continuity between IPDM E/R harness connectors and ground.

IPDM E/R connector	Terminal	Ground	Continuity
E8	38		Ground
	50		
E9	60	Ground	Yes
	60		

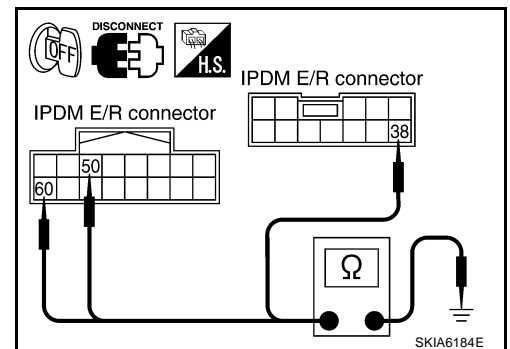

OK or NG

OK >> INSPECTION END

NG >> Repair harness or connector.

IPDM E/R (INTELLIGENT POWER DISTRIBUTION MODULE ENGINE ROOM)

Inspection With CONSULT-II (Self-Diagnosis)

NKS000ED

CAUTION:

If CONSULT-II is used with no connection of CONSULT-II CONVERTER, malfunctions might be detected in self-diagnosis depending on control unit which carry out CAN communication.

1. CHECK SELF DIAGNOSTIC RESULT

1. Connect CONSULT-II and select "IPDM E/R" on the Diagnosis System Selection screen.
2. Select "SELF-DIAG RESULTS" on the "SELECT DIAG MODE" screen.
3. Check display content in self diagnosis results.

CONSULT-II display	CONSULT-II display code	TIME		Details of diagnosis result
		CRNT	PAST	
NO DTC IS DETECTED. FURTHER TESTING MAY BE REQUIRED.	—	—	—	No malfunction
CAN COMM CIRC	U1000	×	×	Any of or several items below have errors. <ul style="list-style-type: none">● TRANSMIT DIAG● ECM● BCM

NOTE:

The details for display of the period are as follows:

- CRNT: Error currently detected with IPDM E/R.
- PAST: Error detected in the past and memorized with IPDM E/R.

Contents displayed

NO DTC IS DETECTED.FURTHER TESTING MAY BE REQUIRED.>>INSPECTION END

CAN COMM CIRC>>After print-out of the monitor items, refer to [LAN-48, "CAN System Specification Chart"](#) .

IPDM E/R (INTELLIGENT POWER DISTRIBUTION MODULE ENGINE ROOM)

Removal and Installation of IPDM E/R

REMOVAL

NKS000EE

1. Remove battery. Refer to [SC-9, "Removal and Installation"](#) .
2. Remove IPDM E/R cover A. While pressing pawl on backside of IPDM E/R cover B toward vehicle front to unlock, lift up IPDM E/R.

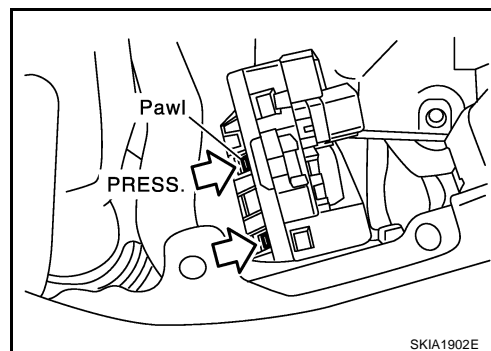
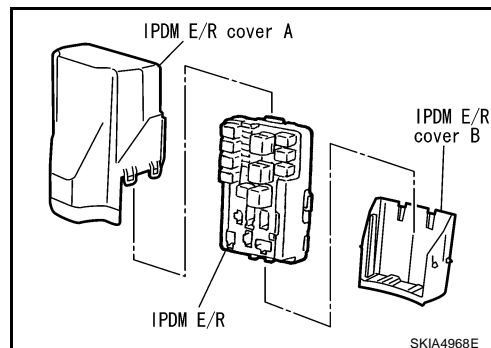

3. While pressing pawls on right and left side of IPDM E/R, remove IPDM E/R cover B from IPDM E/R.
4. Remove harness connector from IPDM E/R.

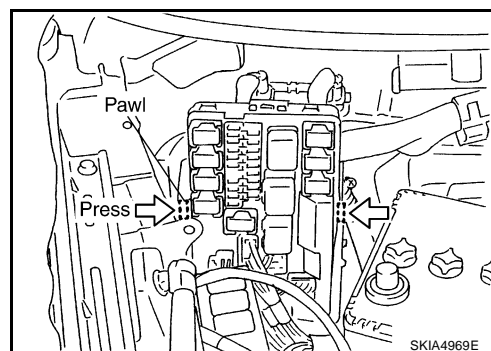

INSTALLATION

Installation is the reverse order of removal.

A
B
C
D
E
F
G
H
I
J
PG
L
M

GROUND

Ground Distribution MAIN HARNESS/TYPE 1

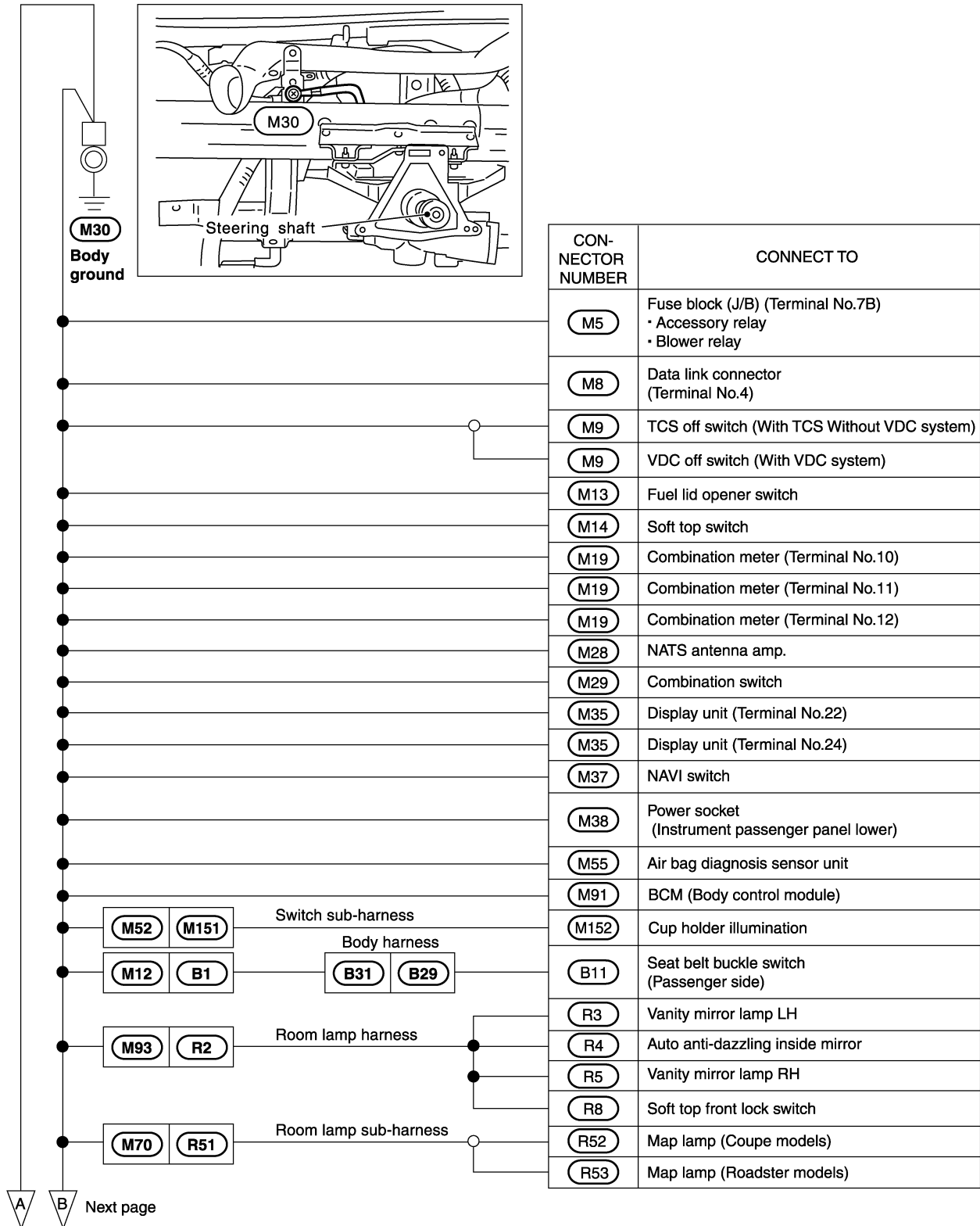

A B Next page

GROUND

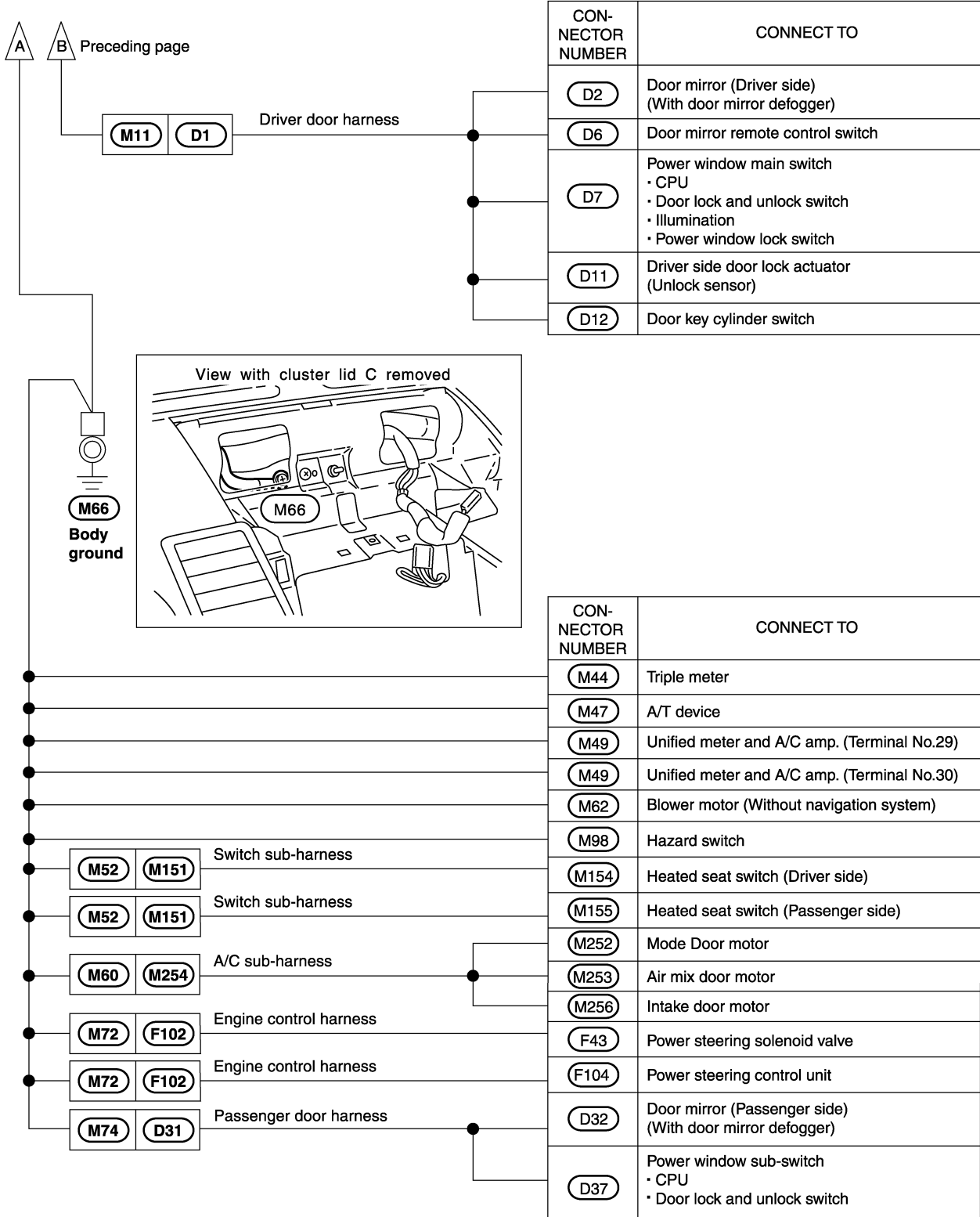

A
B
C
D
E
F
G
H
I
J
PG
L
M

CKIT0729E

GROUND

MAIN HARNESS/TYPE 2

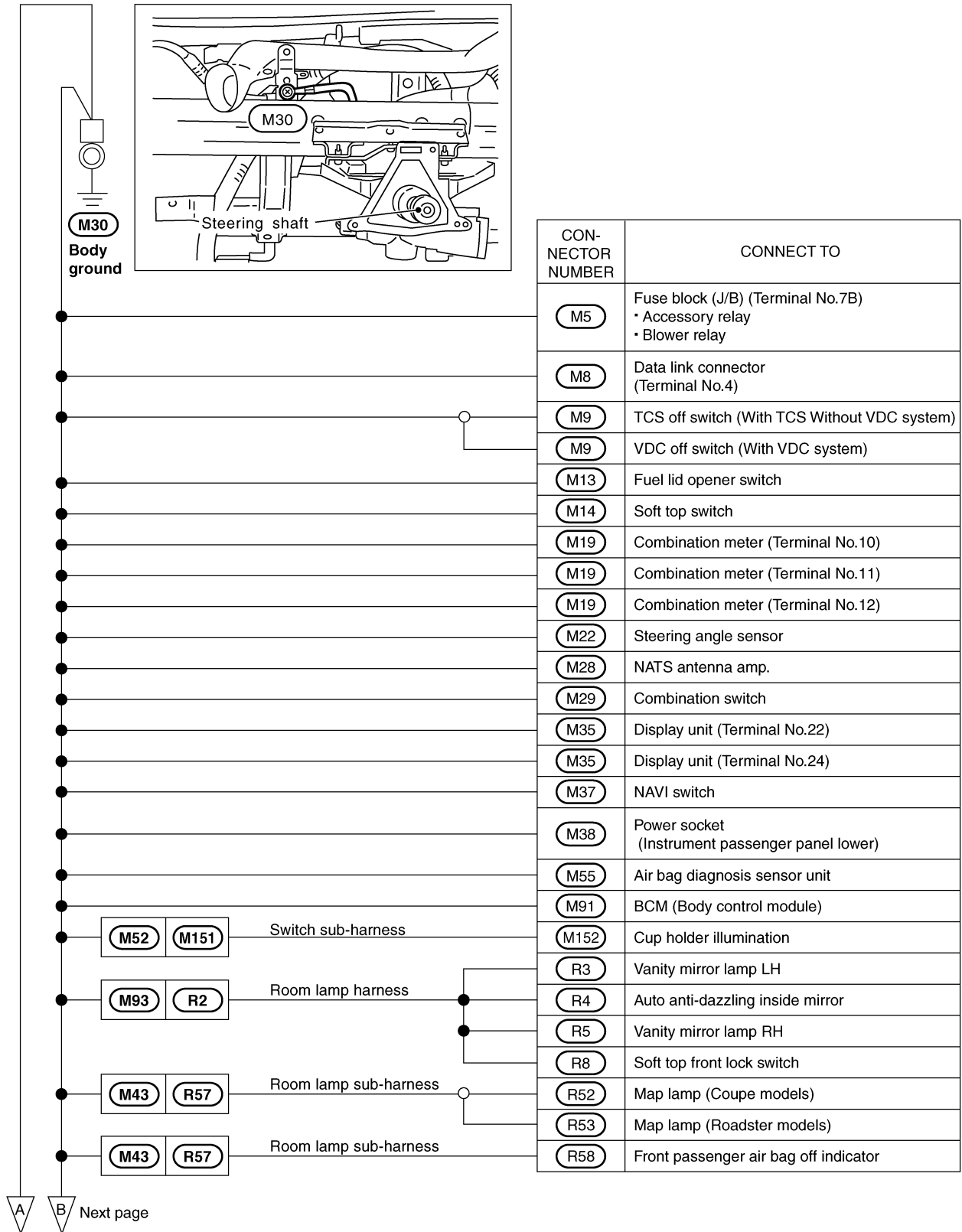

A B Next page

CKIT0851E

GROUND

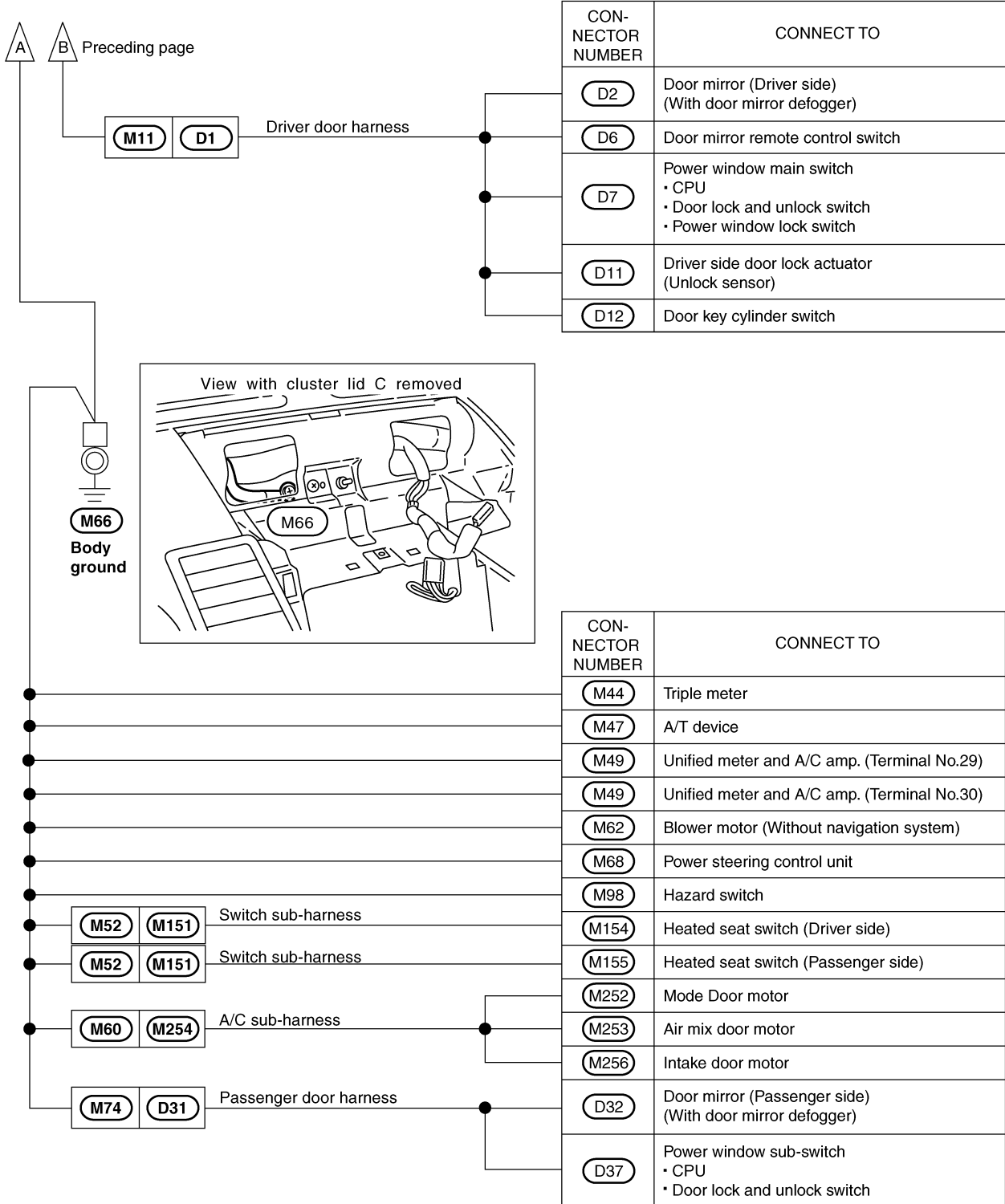

A
B
C
D
E
F
G
H
I
J
PG
L
M

CKIT0852E

GROUND

ENGINE ROOM HARNESS/TYPE 1

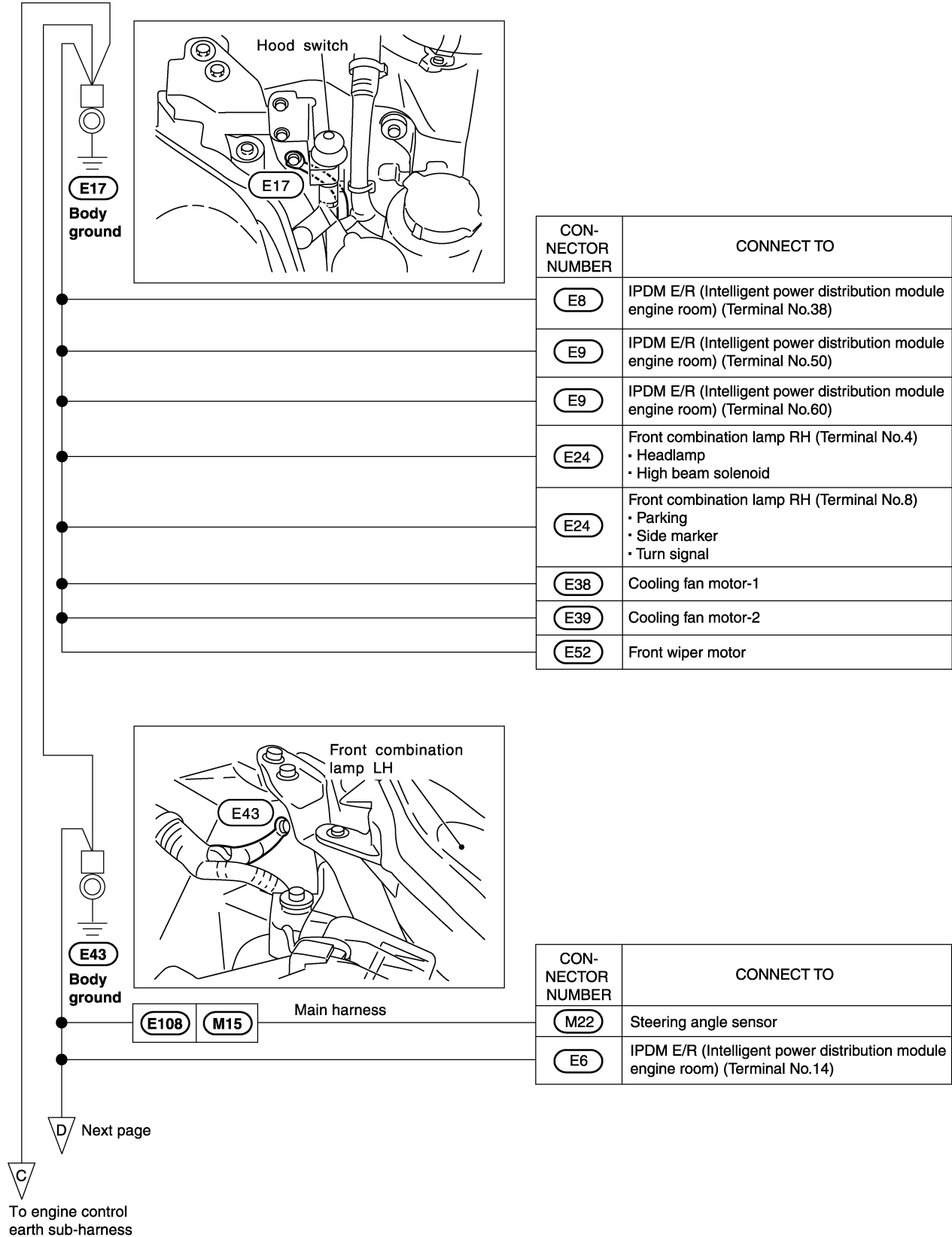

CKIT0730E

GROUND

D Preceding page

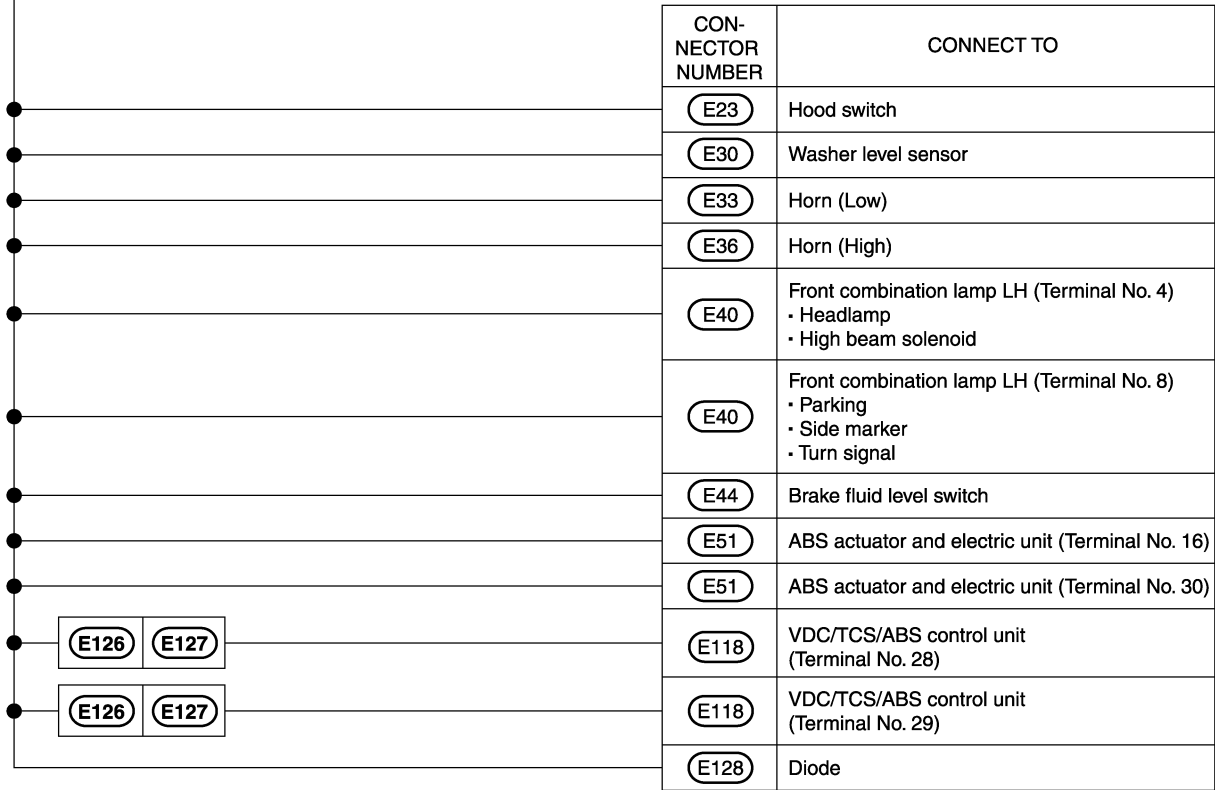

A
B
C
D
E
F
G
H
I
J
L
M

PG

CKIT0731E

GROUND

CON-NECTOR NUMBER	CONNECT TO
E37	Shield wire (Crash zone sensor)

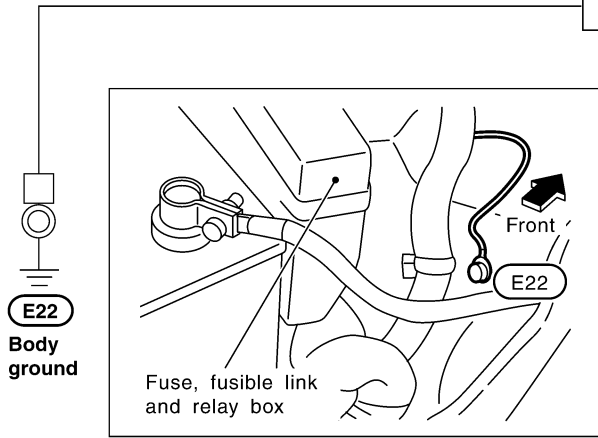

CON-NECTOR NUMBER	CONNECT TO
E211	Alternator (E)

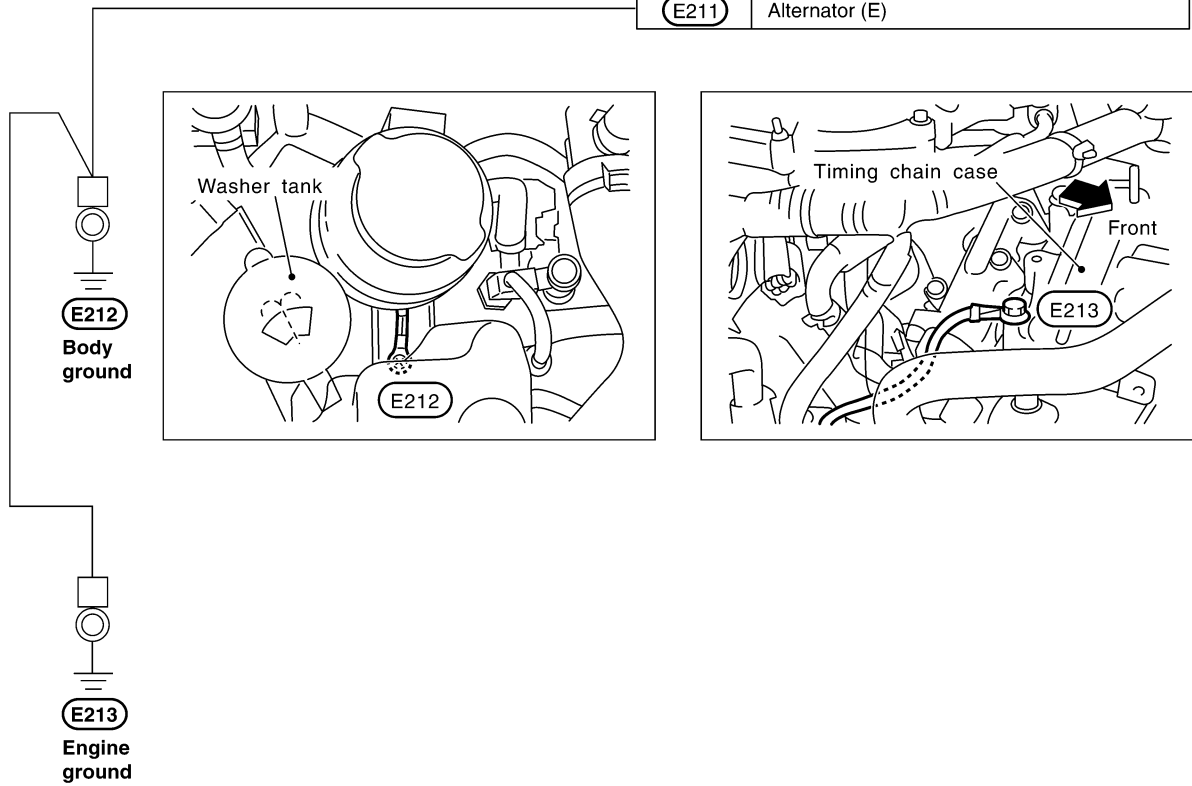

CKIT0170E

GROUND

ENGINE ROOM HARNESS/TYPE 2

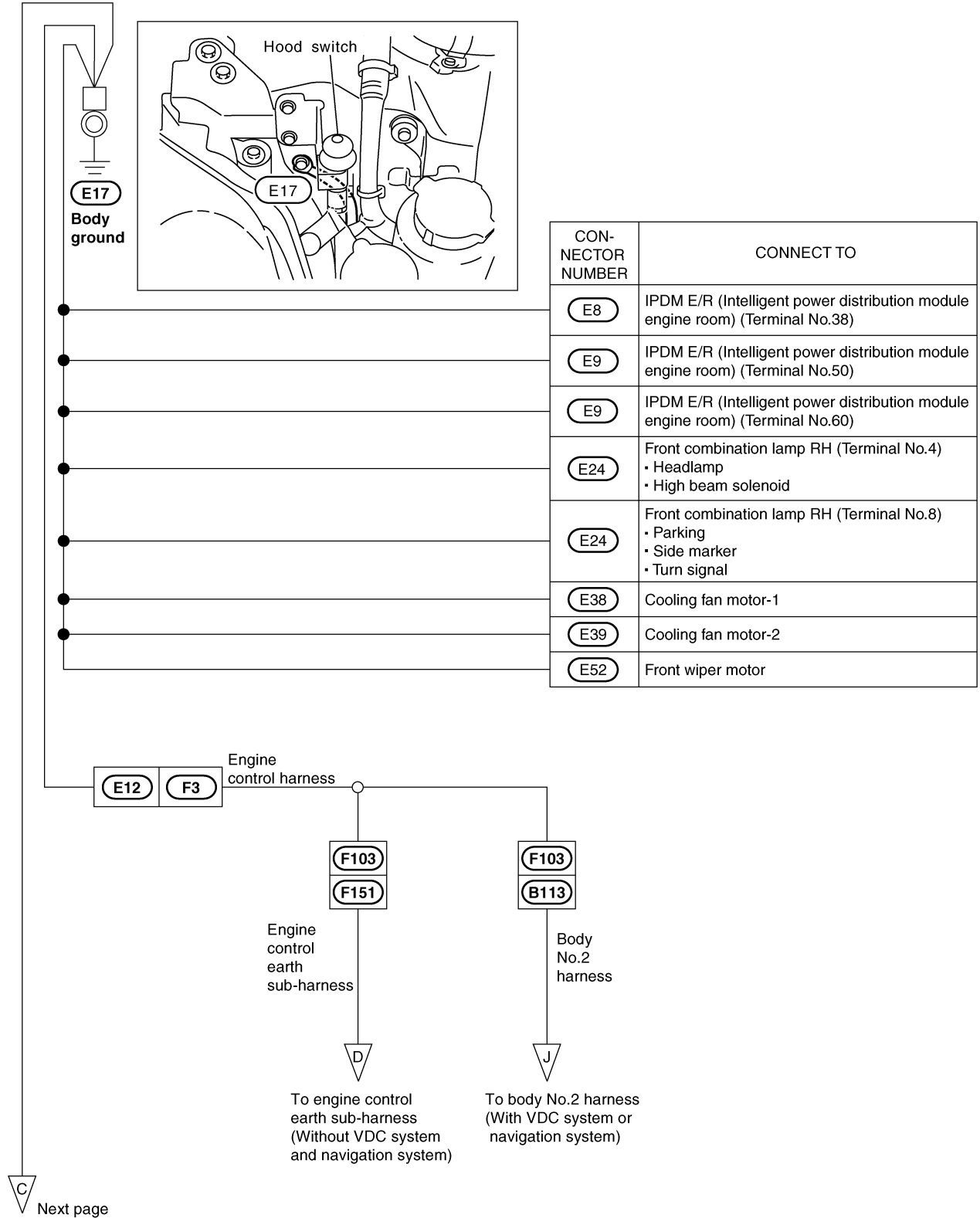

A
B
C
D
E
F
G
H
I
J
PG
L
M

CKIT0853E

GROUND

C Preceding page

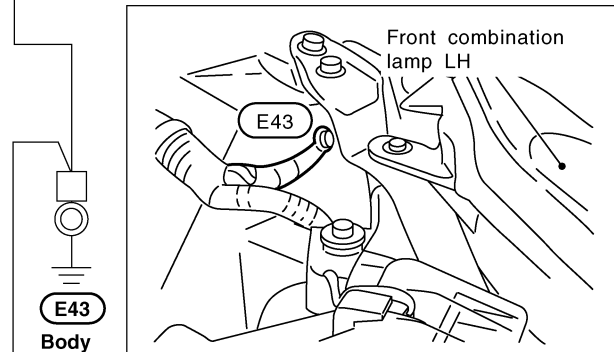

E43
Body ground

CON-NECTOR NUMBER	CONNECT TO
E6	IPDM E/R (Intelligent power distribution module engine room) (Terminal No.14)
E23	Hood switch
E30	Washer level sensor
E33	Horn (Low)
E36	Horn (High)
E40	Front combination lamp LH (Terminal No. 4) • Headlamp • High beam solenoid
E40	Front combination lamp LH (Terminal No. 8) • Parking • Side marker • Turn signal
E44	Brake fluid level switch
E51	ABS actuator and electric unit (Terminal No. 16)
E51	ABS actuator and electric unit (Terminal No. 30)
E128	Diode

CKIT0854E

GROUND

A
B
C
D
E
F
G
H
I
J
PG
L
M

CON-NECTOR NUMBER	CONNECT TO
E37	Shield wire (Crash zone sensor)

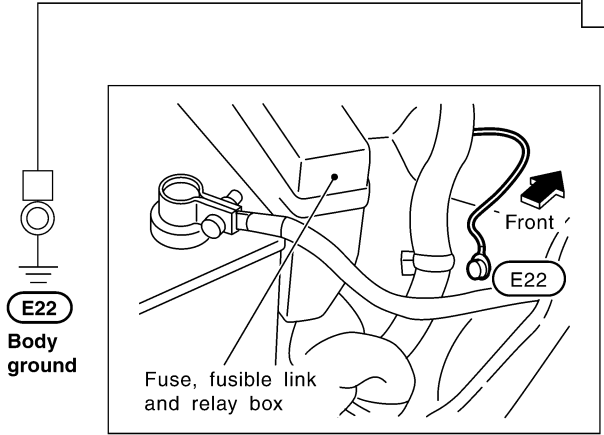

CON-NECTOR NUMBER	CONNECT TO
E211	Alternator (E)

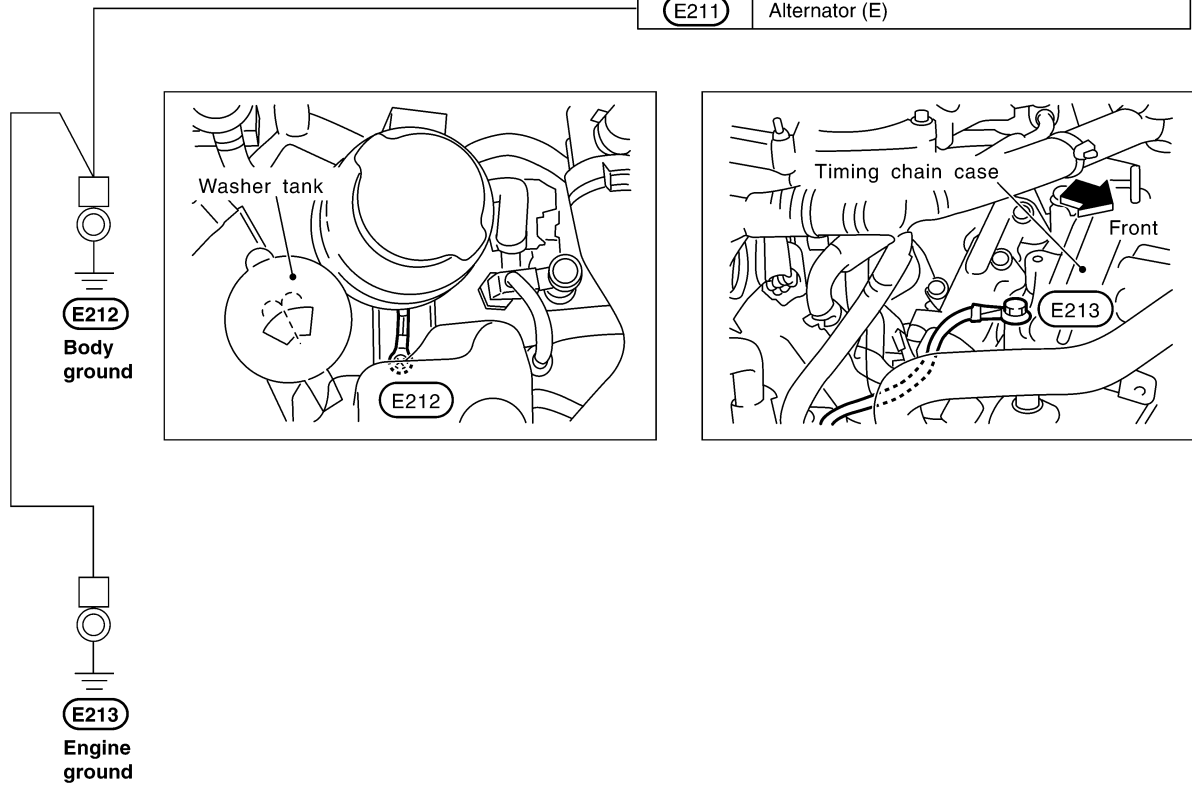

CKIT0170E

GROUND

ENGINE CONTROL HARNESS/TYPE 1

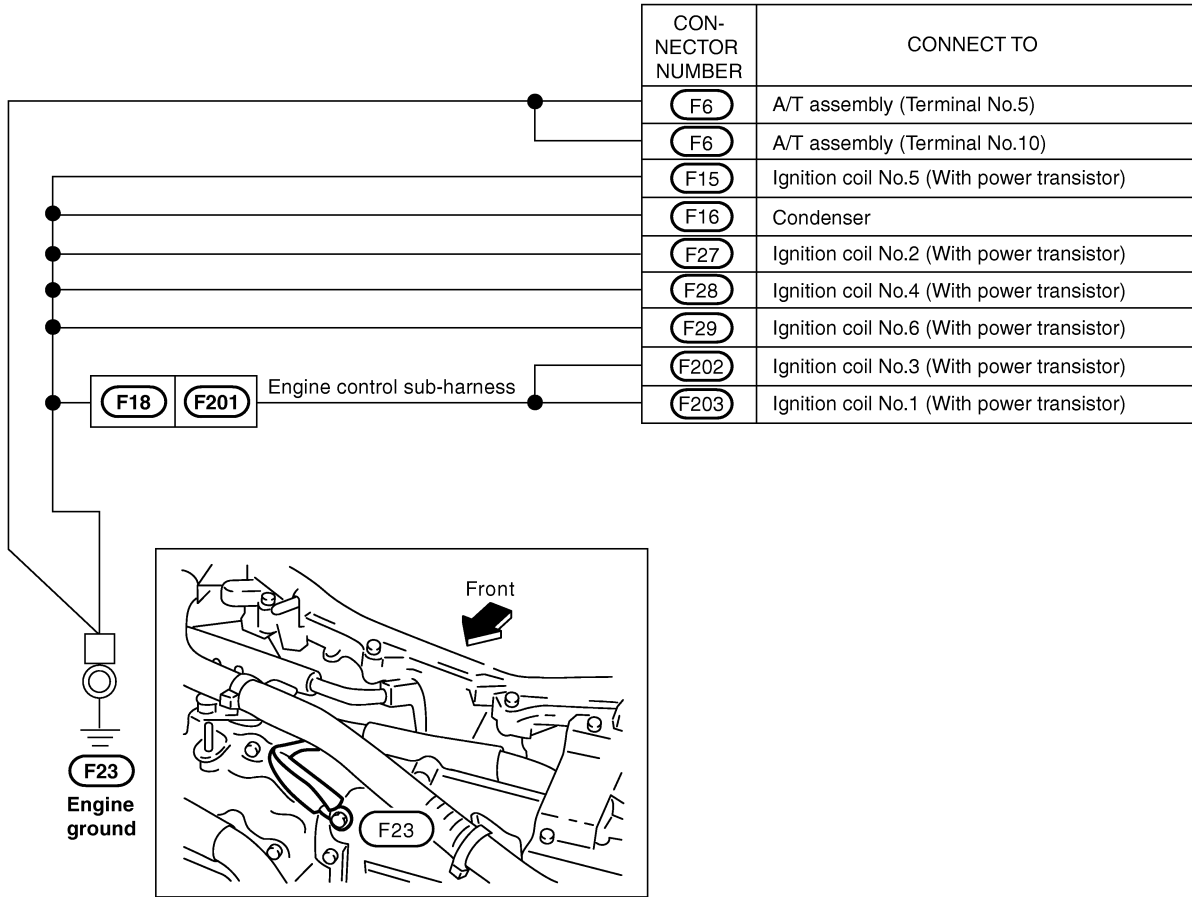

CKIB0204E

GROUND

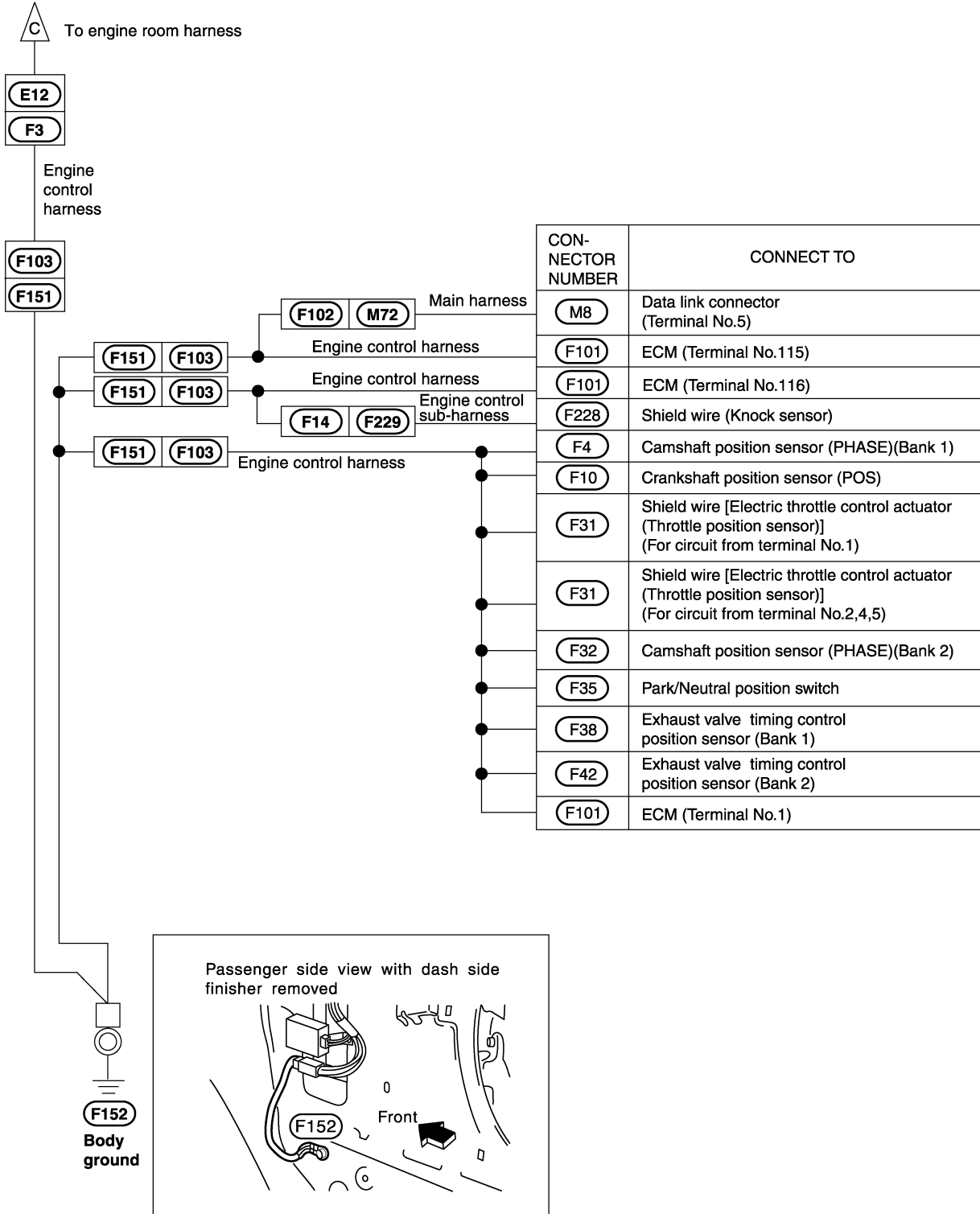

A
B
C
D
E
F
G
H
I
J
PG
L
M

PG

CKIT0732E

GROUND

ENGINE CONTROL HARNESS/TYPE 2

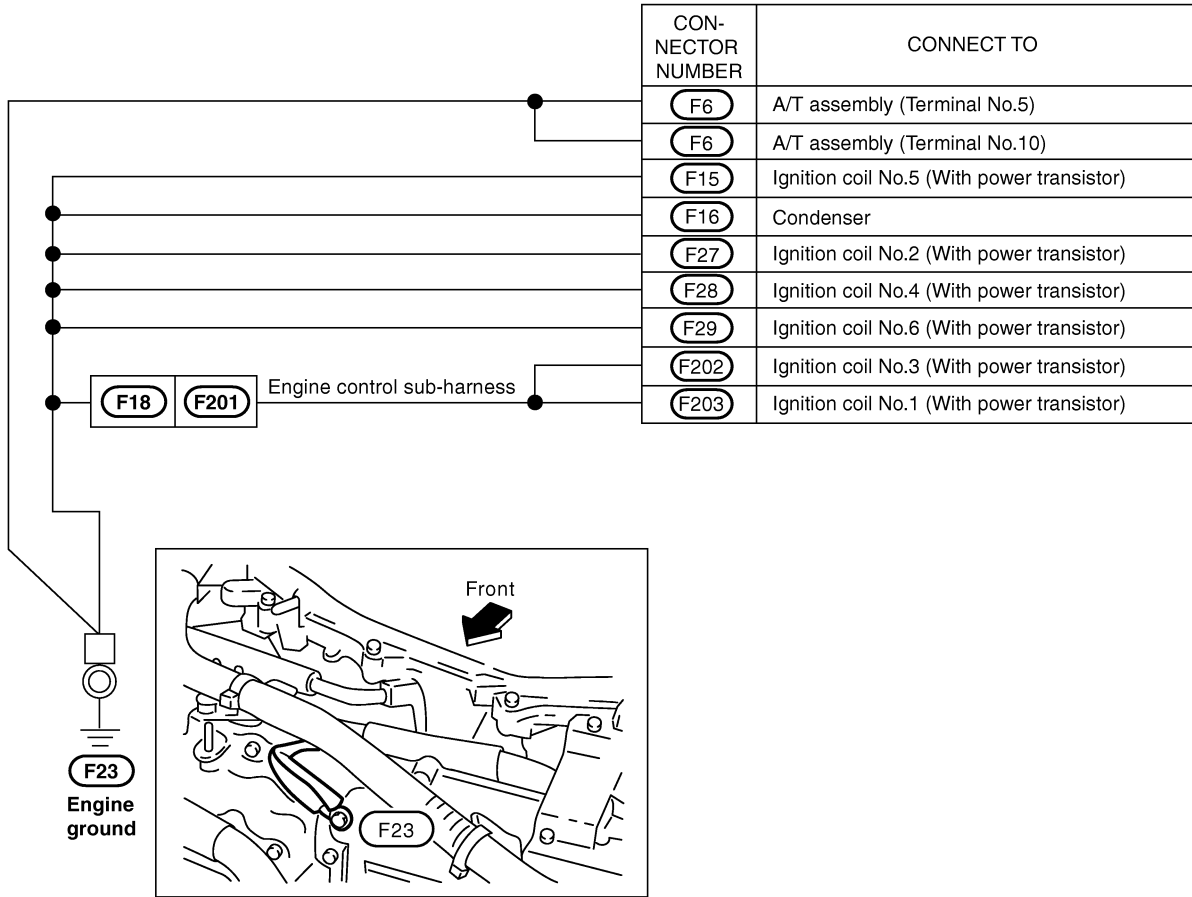

CKIB0204E

GROUND

△ To engine room harness

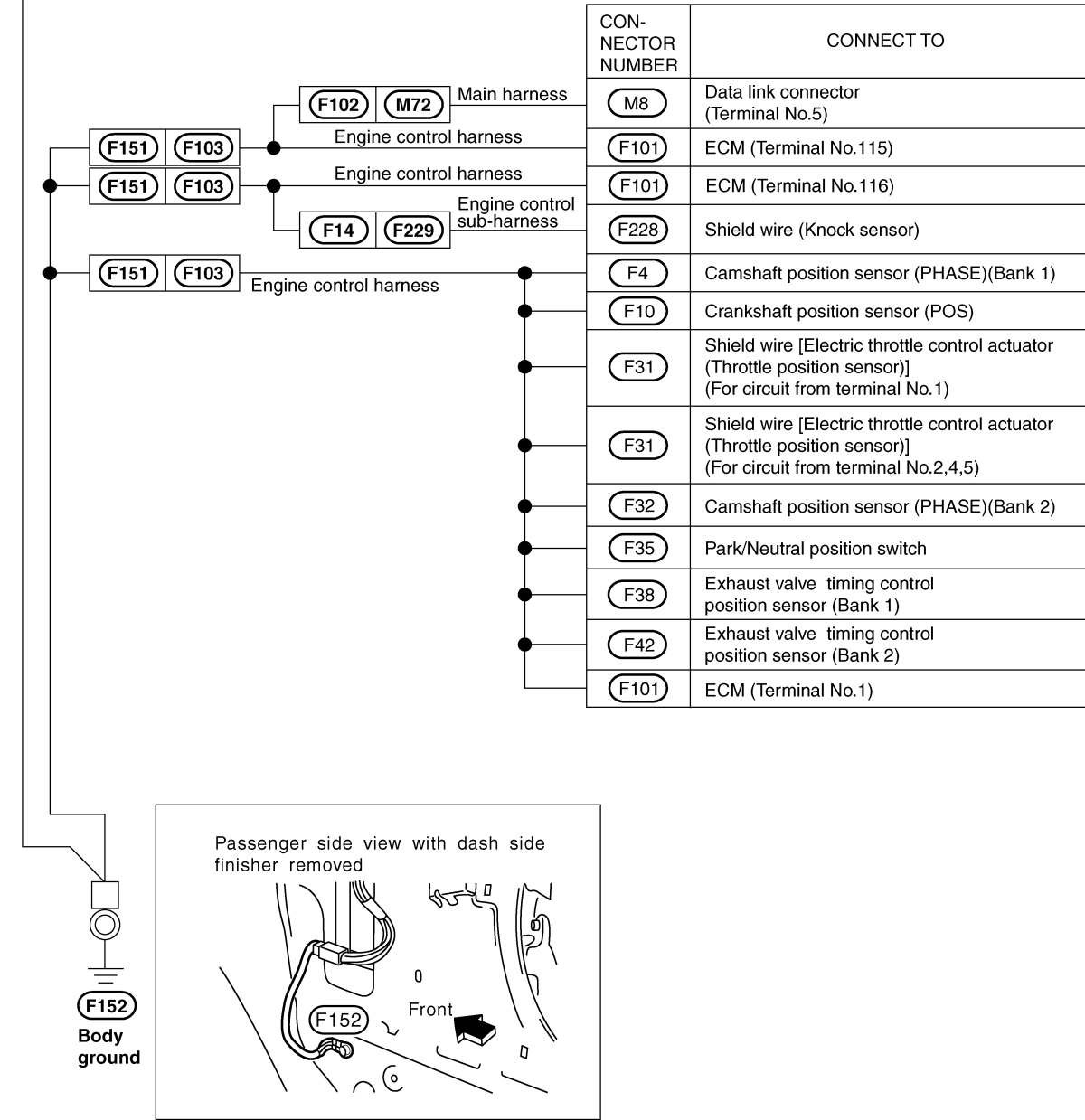

A
B
C
D
E
F
G
H
I
J
PG
L
M

CKIT0855E

GROUND

BODY HARNESS/TYPE 1

Coupe Models

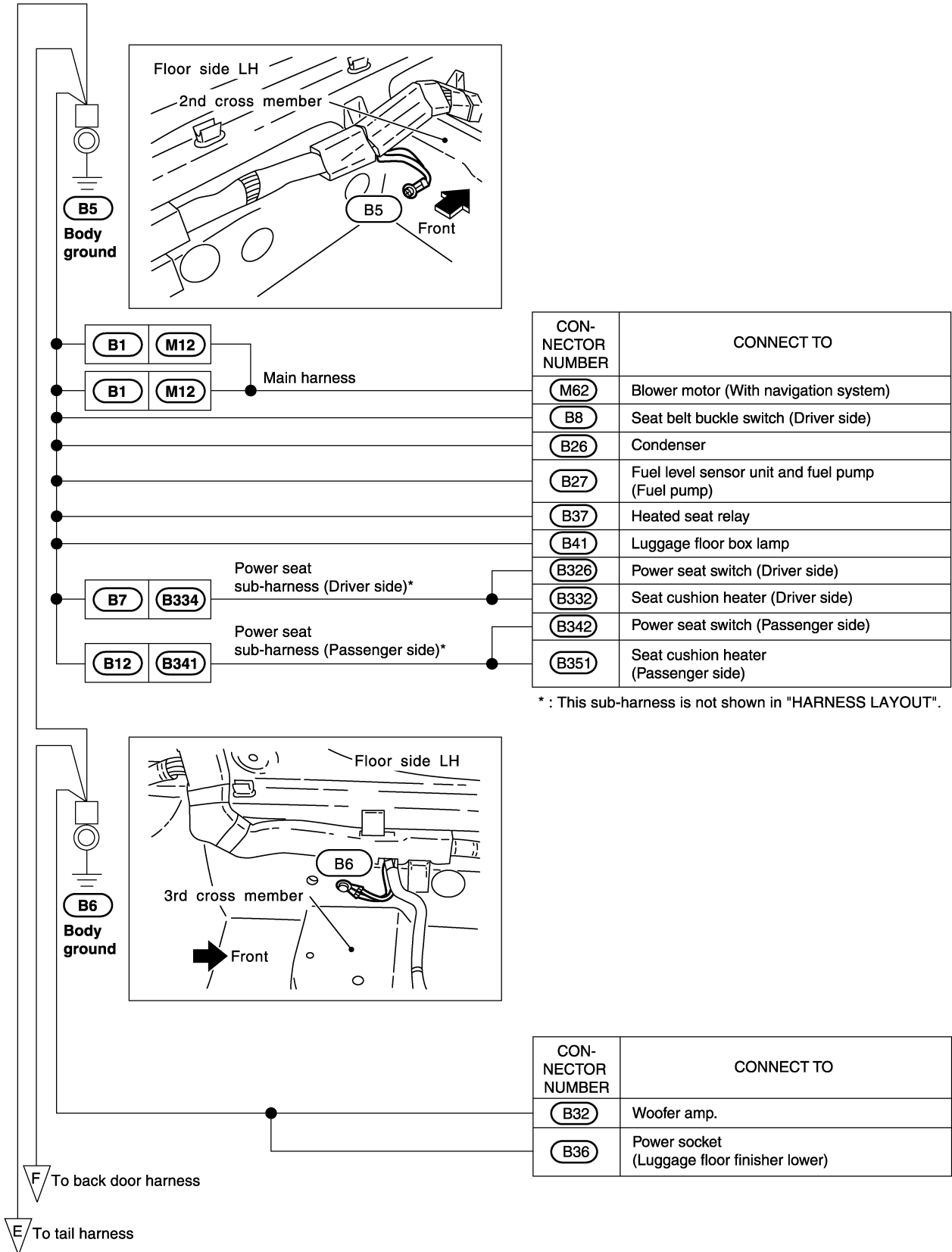

CKIT0733E

GROUND

A
B
C
D
E
F
G
H
I
J
PG
L
M

CON-NECTOR NUMBER	CONNECT TO
B15	Shield wire [LH side air bag (Satellite) sensor]

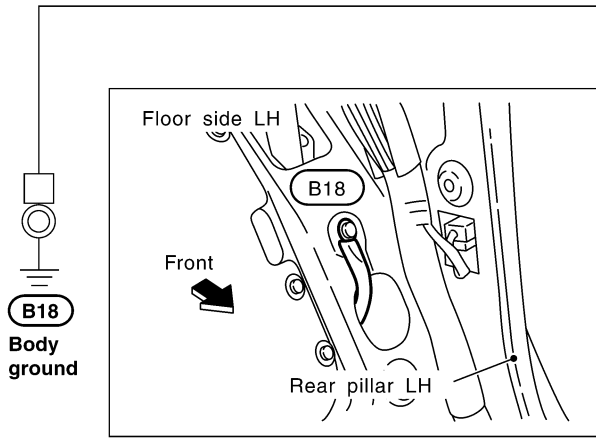

CON-NECTOR NUMBER	CONNECT TO
B21	Shield wire [RH side air bag (Satellite) sensor]

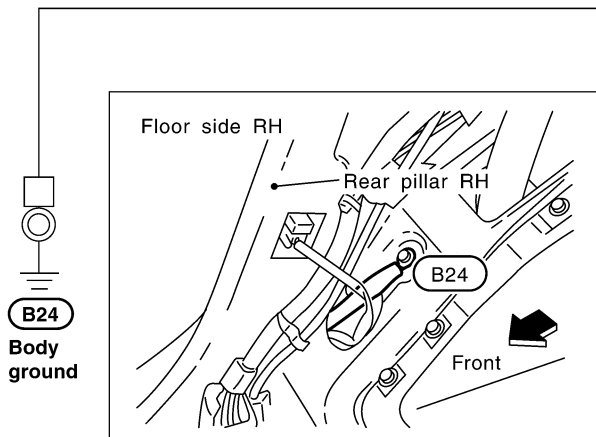

CKIT0174E

GROUND

Roadster Models

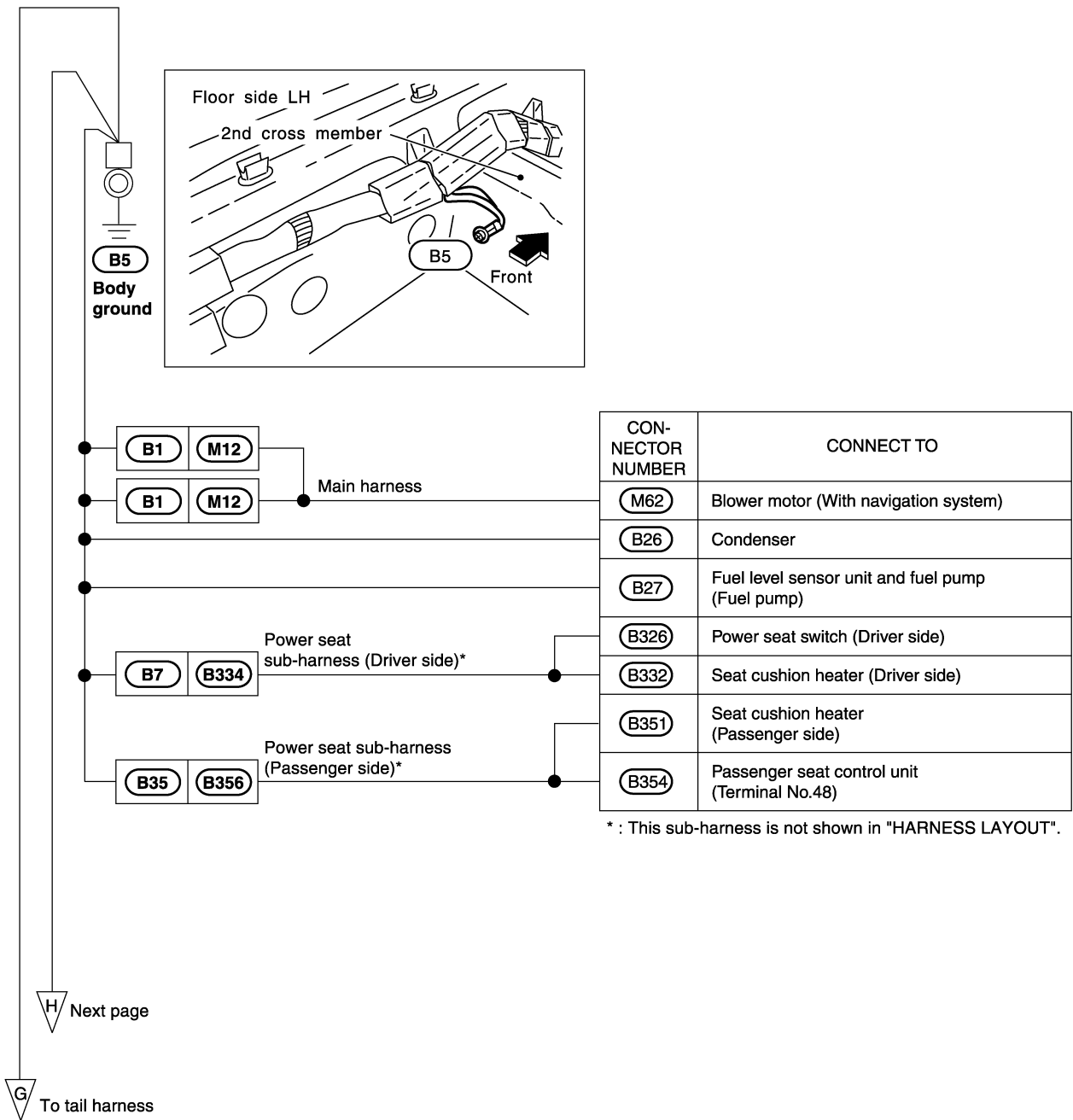

CKIT0734E

GROUND

H Preceding page

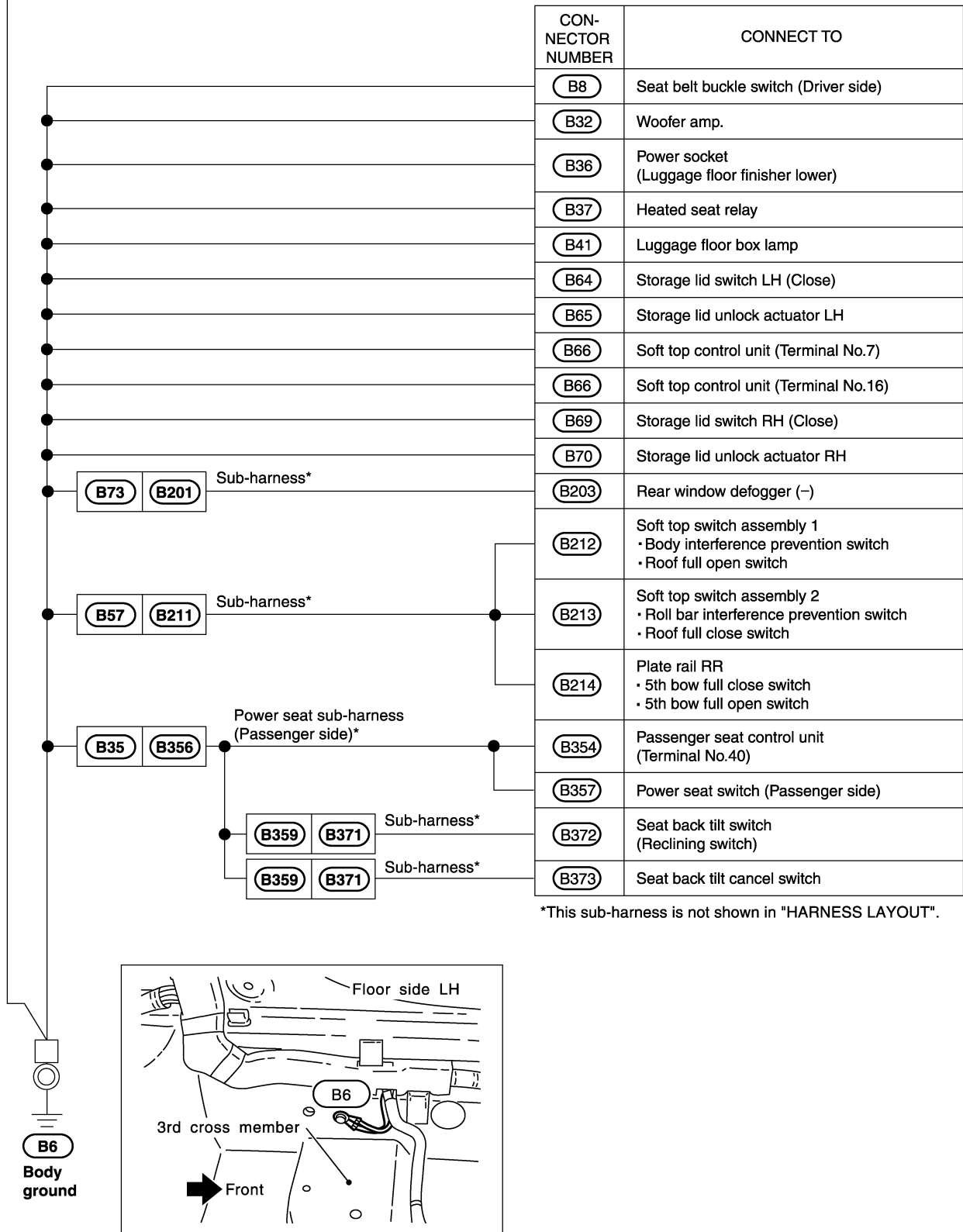

A
B
C
D
E
F
G
H
I
J
PG
L
M

CKIT0735E

GROUND

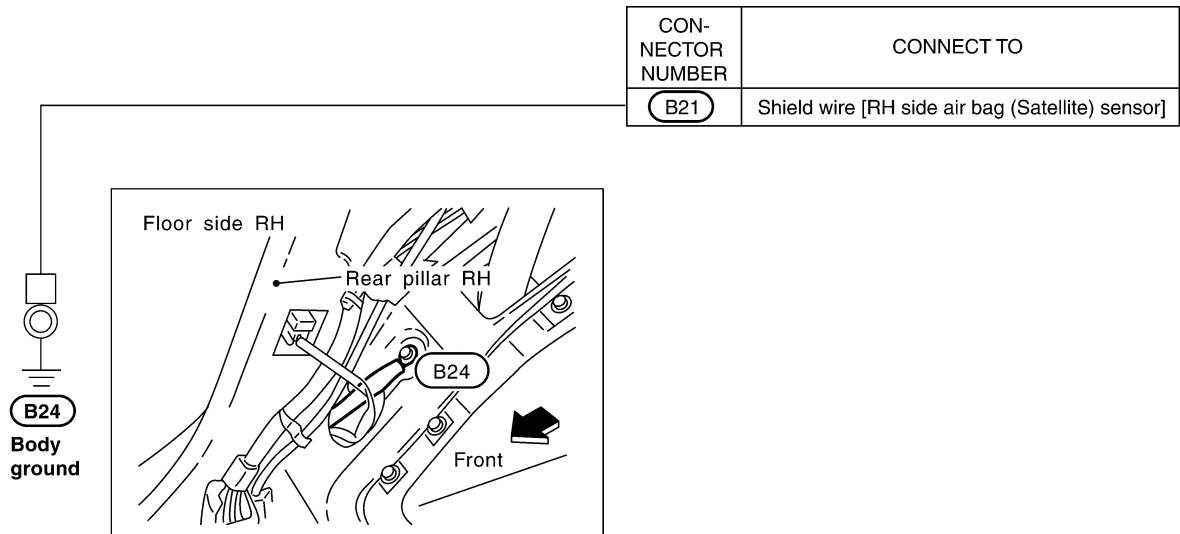
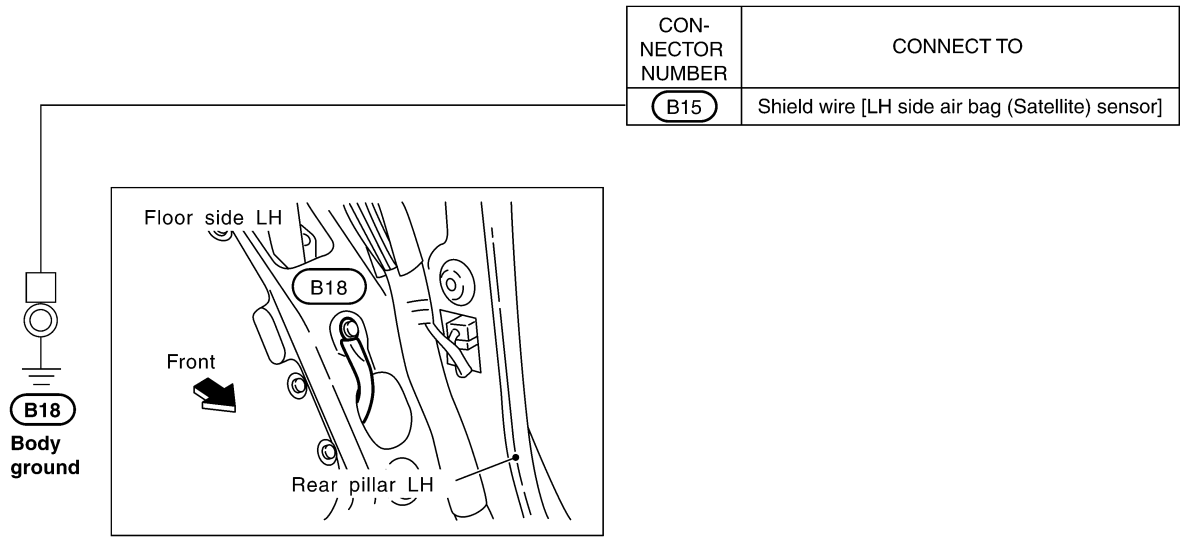

CKIT0174E

GROUND

BODY HARNESS/TYPE 2

Coupe Models

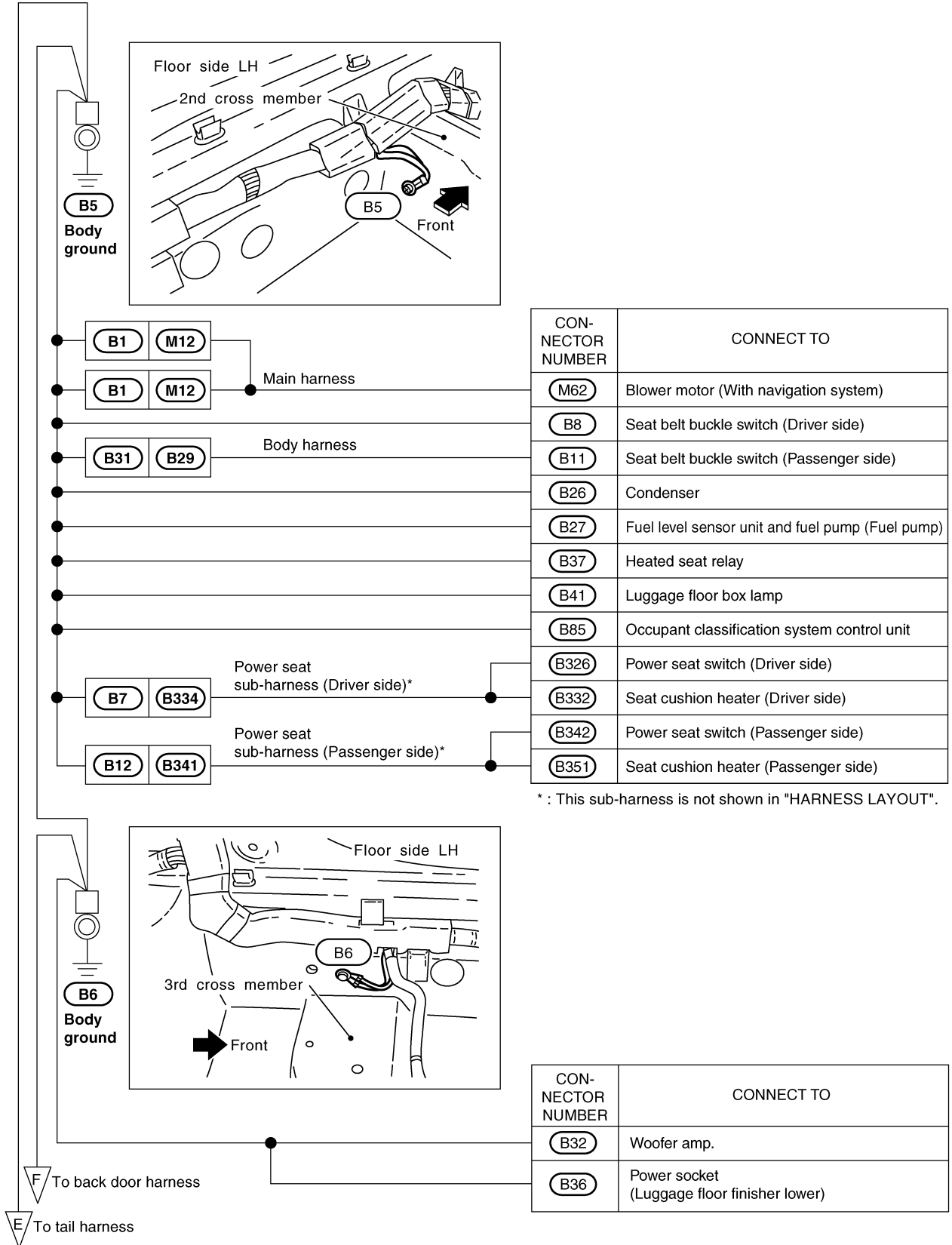

A
B
C
D
E
F
G
H
I
J
PG
L
M

GROUND

Roadster Models

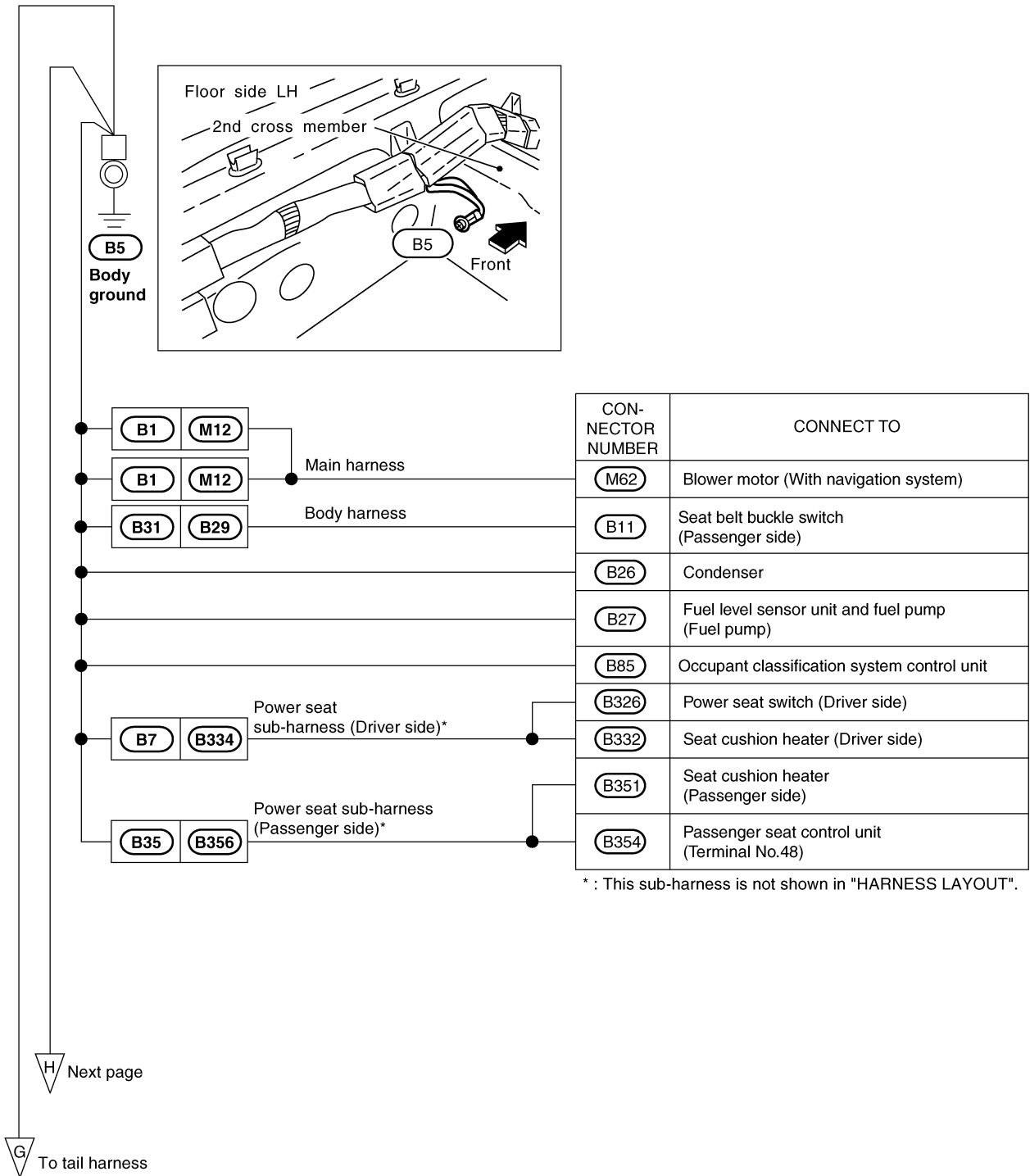

CKIT0857E

GROUND

H Preceding page

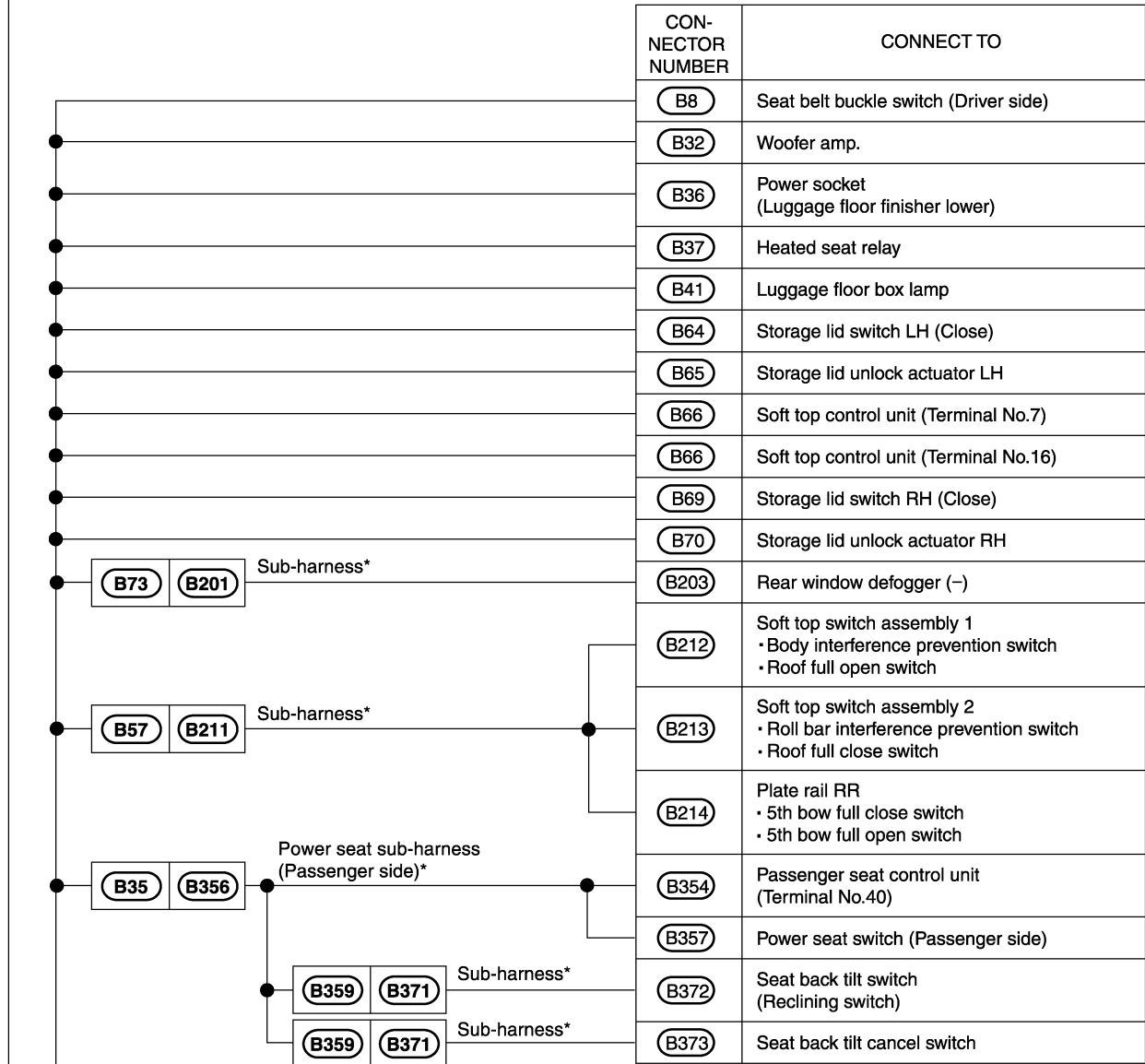

*This sub-harness is not shown in "HARNESS LAYOUT".

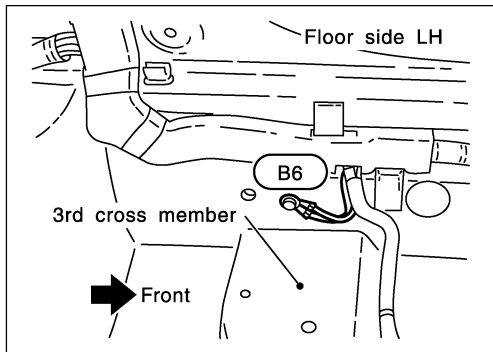

B6
Body ground

CKIT0735E

GROUND

BODY NO. 2 HARNESS/TYPE 1

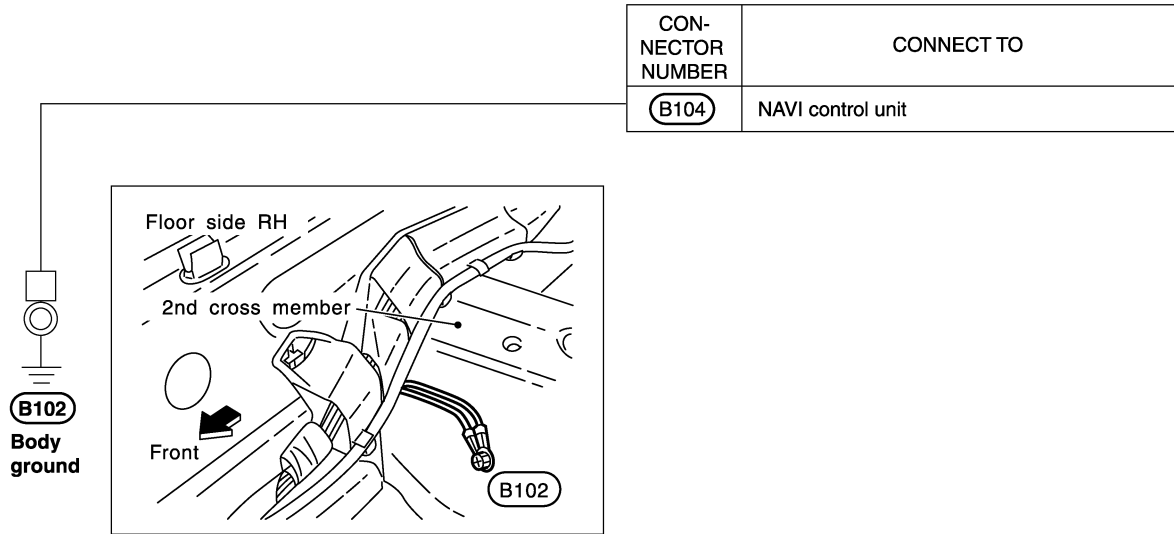

CKIT0736E

GROUND

BODY NO. 2 HARNESS/TYPE 2

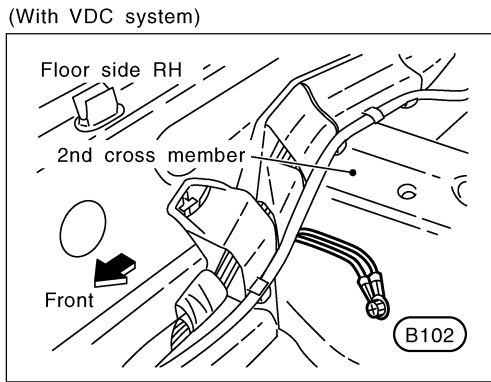
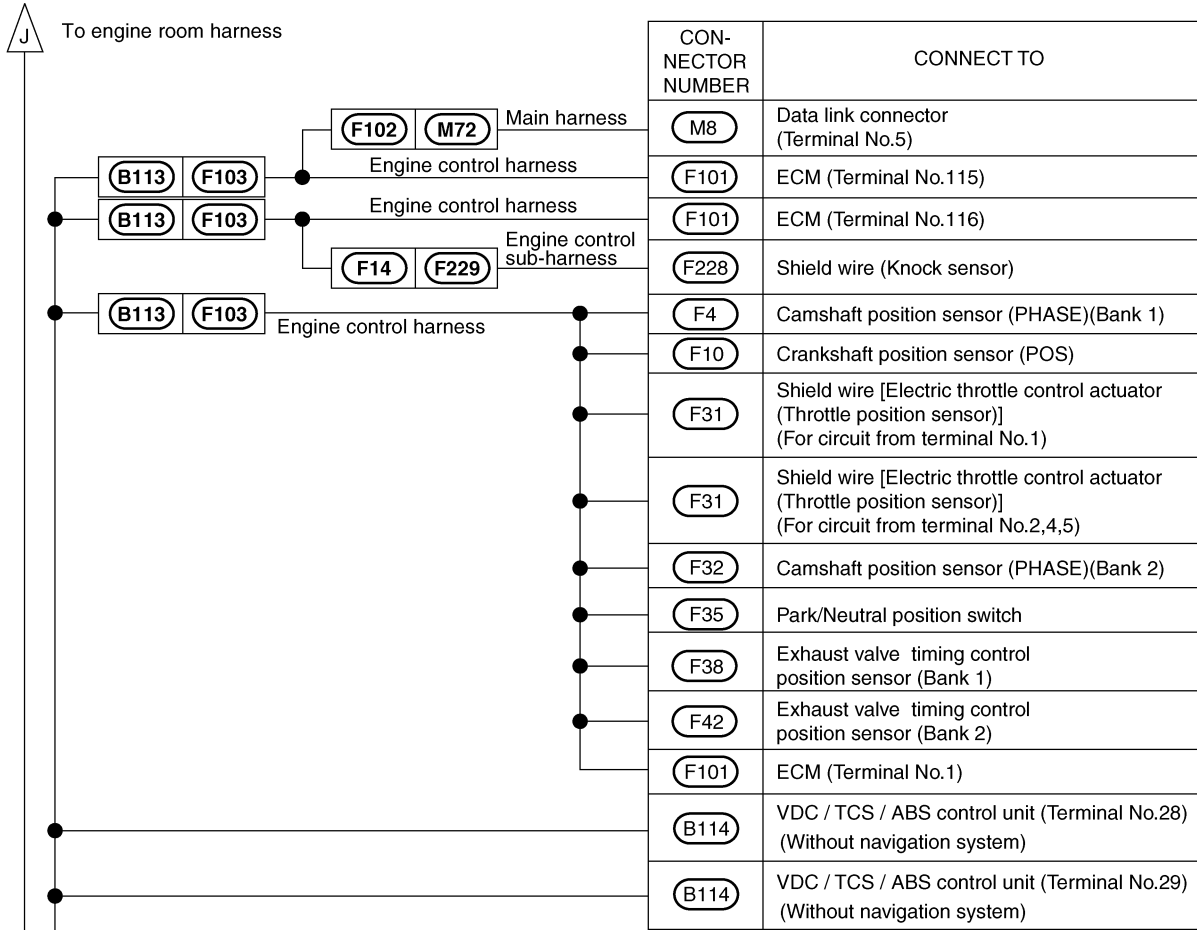

(B102)
Body ground

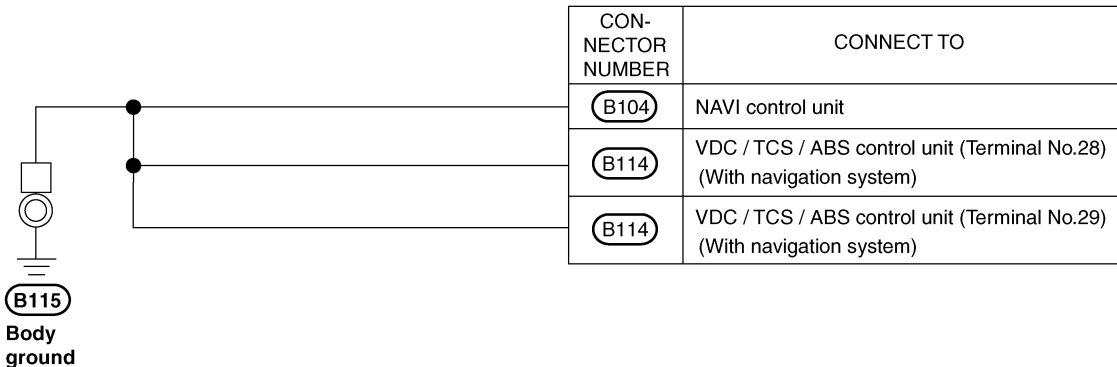

(B115)
Body ground

A
B
C
D
E
F
G
H
I
J
PG
L
M

CKIT0858E

GROUND

TAIL HARNESS/TYPE 1 Coupe Models

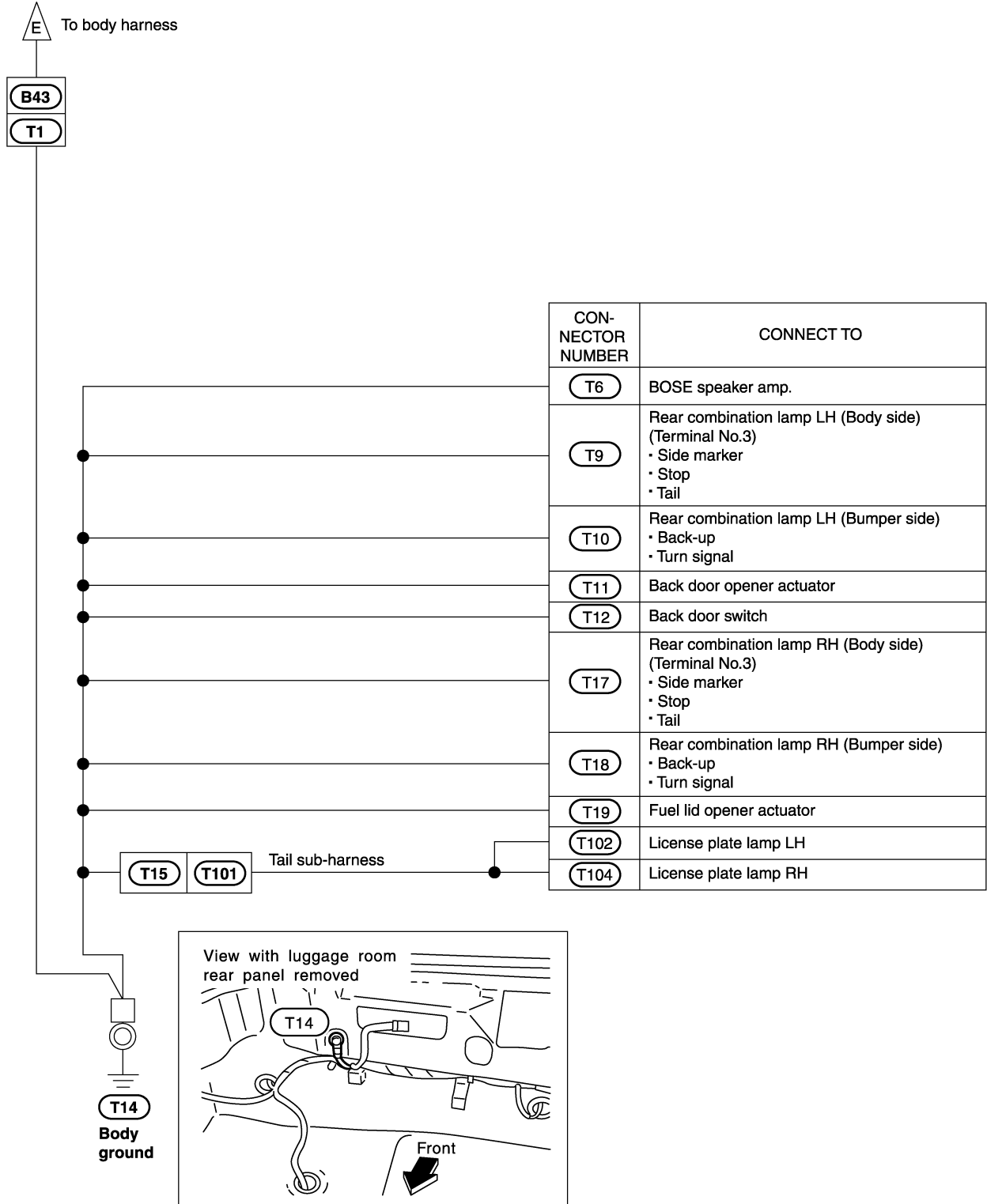

CKIT0737E

GROUND

Roadster Models

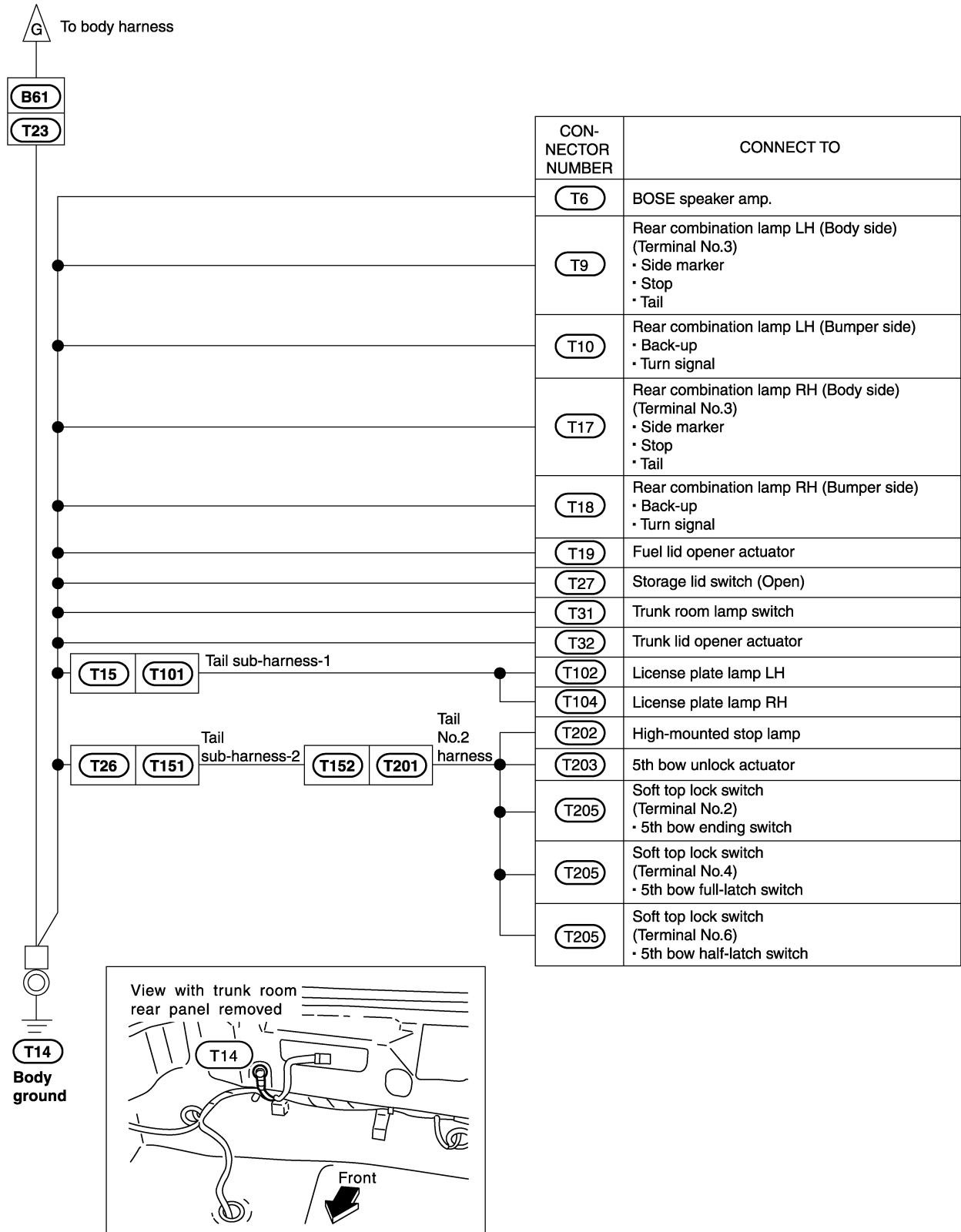

A
B
C
D
E
F
G
H
I
J
PG
L
M

CKIT0738E

GROUND

TAIL HARNESS/TYPE 2 Coupe Models

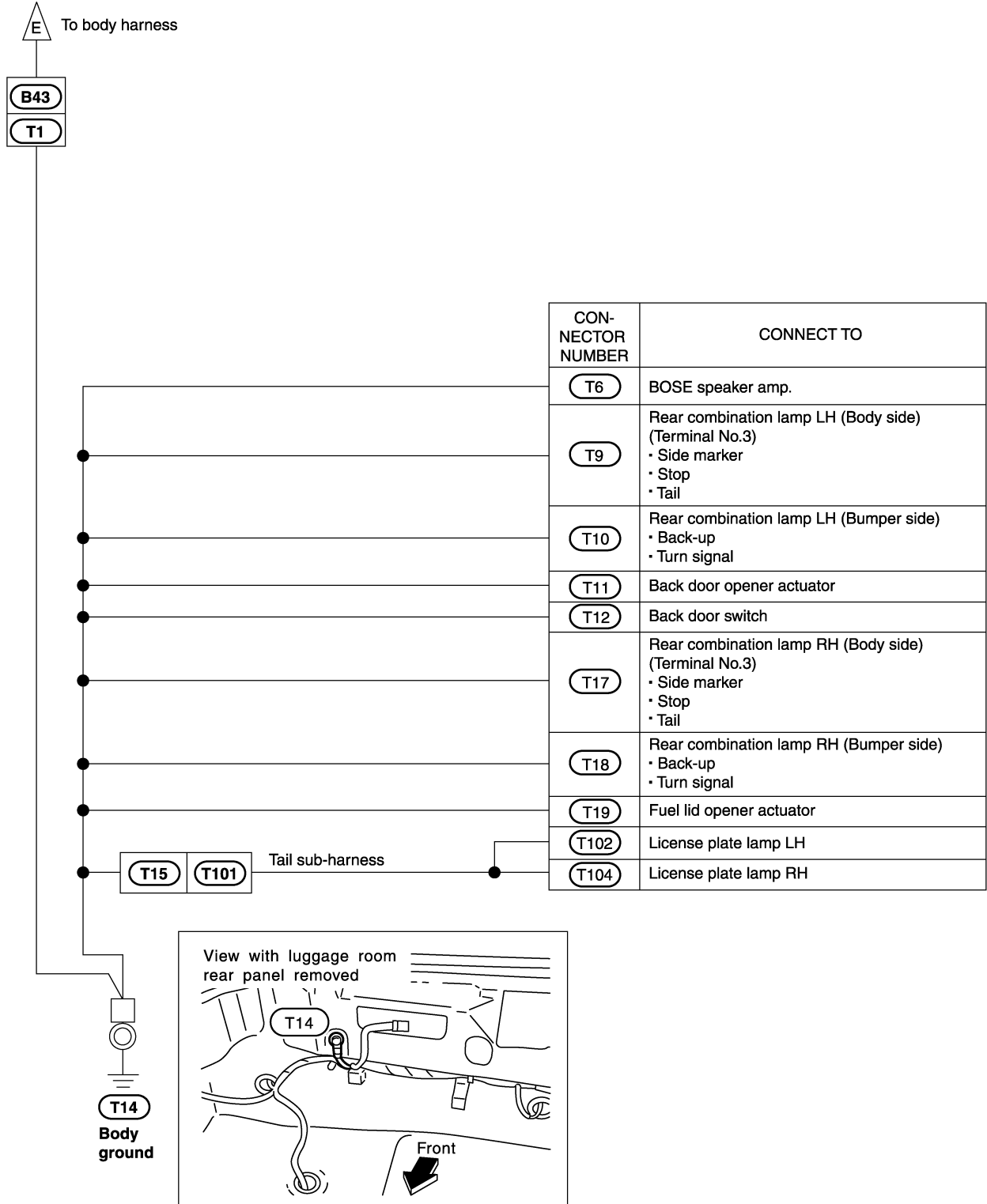

CKIT0737E

GROUND

Roadster Models

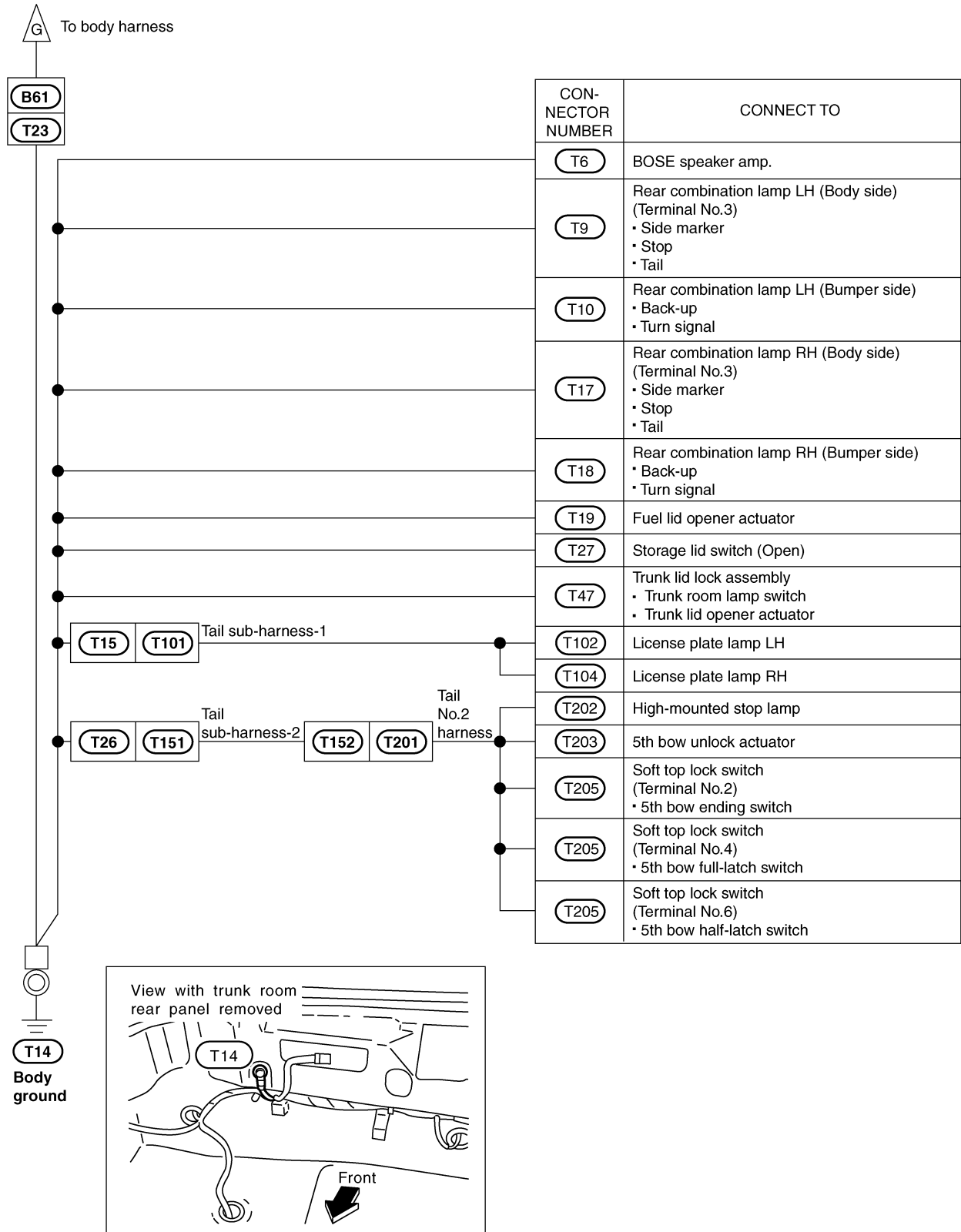

A
B
C
D
E
F
G
H
I
J
PG
L
M

CKIT0859E

GROUND

BACK DOOR HARNESS

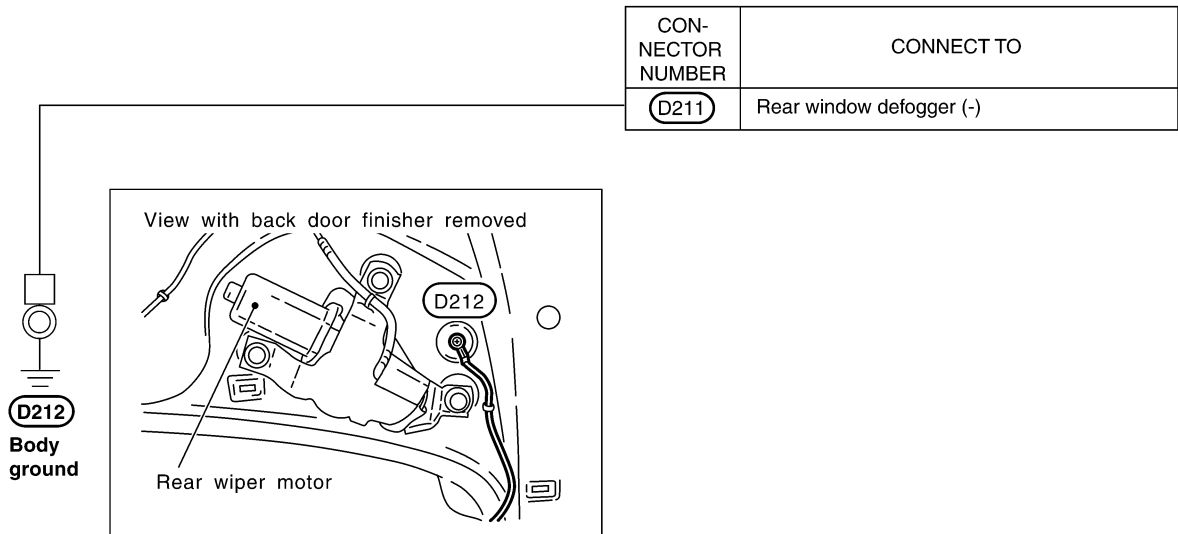
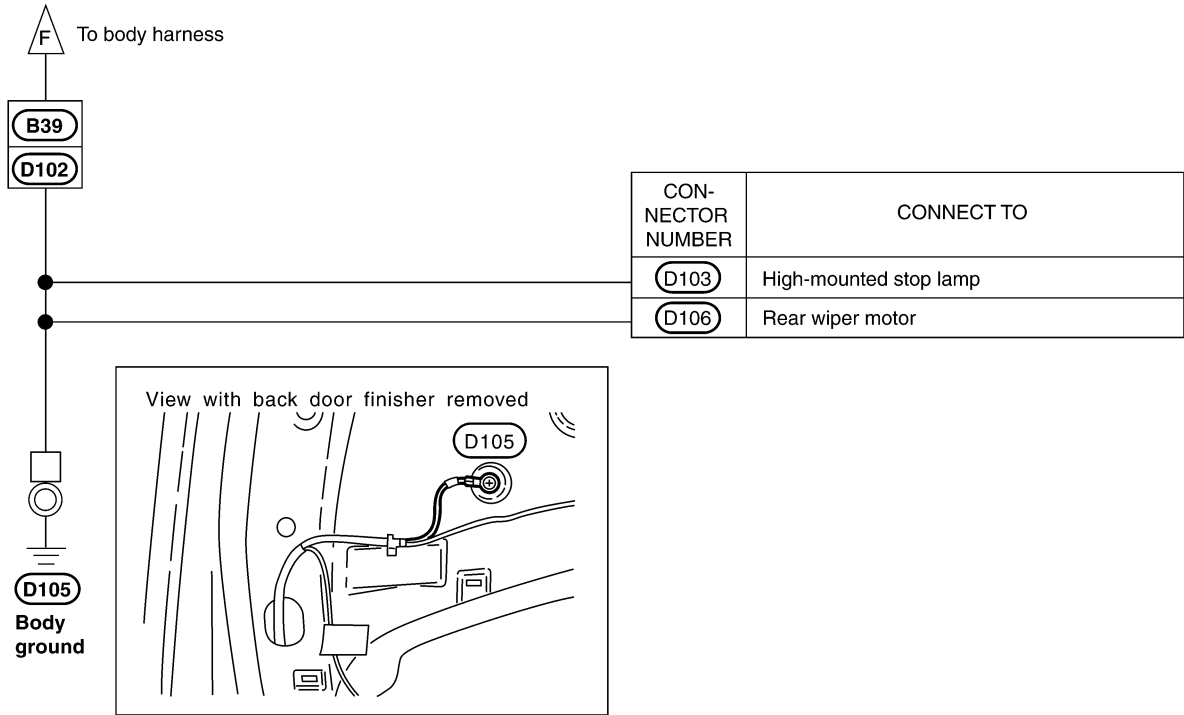

CKIT0464E

HARNESS

HARNESS

PFP:00011

Harness Layout

NKS000EG

HOW TO READ HARNESS LAYOUT

The following Harness Layouts use a map style grid to help locate connectors on the figures:

- Main Harness
- Engine Room Harness (Engine Compartment)
- Engine Control Harness (Engine Compartment)
- Body Harness
- Tail Harness (Roadster models)

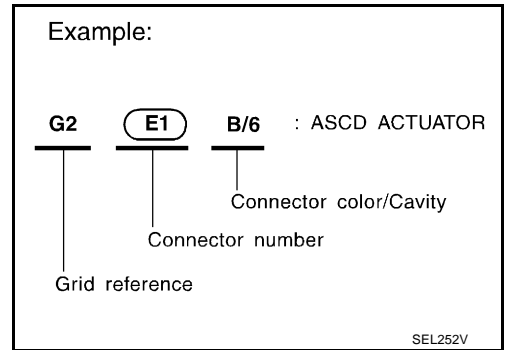

To Use the Grid Reference

1. Find the desired connector number on the connector list.
2. Find the grid reference.
3. On the figure, find the crossing of the grid reference letter column and number row.
4. Find the connector number in the crossing zone.
5. Follow the line (if used) to the connector.

CONNECTOR SYMBOL

Main symbols of connector (in Harness Layout) are indicated in the below.

Connector type	Water proof type		Standard type	
	Male	Female	Male	Female
<ul style="list-style-type: none"> • Cavity: Less than 4 • Relay connector 				
<ul style="list-style-type: none"> • Cavity: From 5 to 8 				
<ul style="list-style-type: none"> • Cavity: More than 9 				
<ul style="list-style-type: none"> • Ground terminal etc. 	—			

CKIT0108E

A
B
C
D
E
F
G
H
I
J
PG
L
M

HARNESS

OUTLINE

Coupe Models

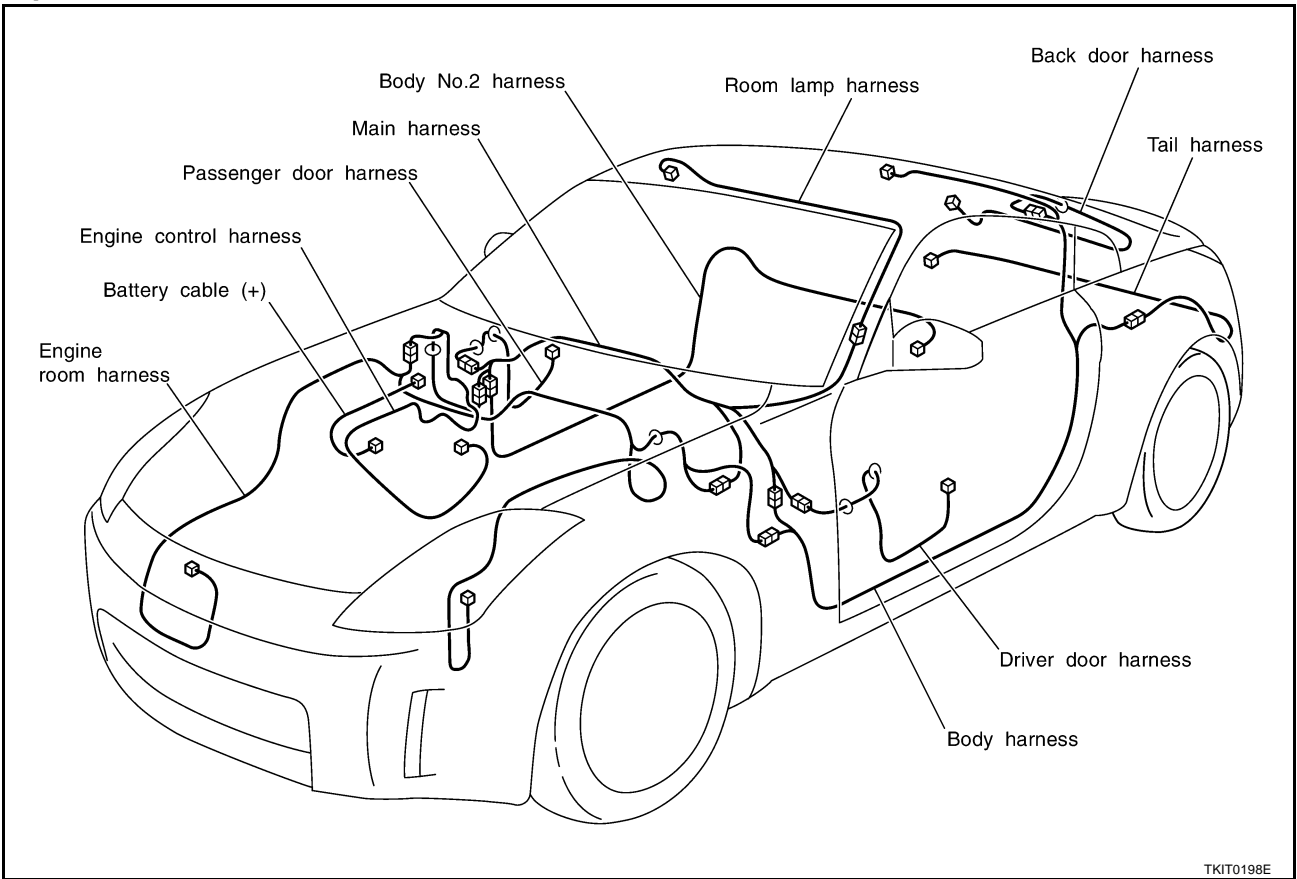

Roadster Models

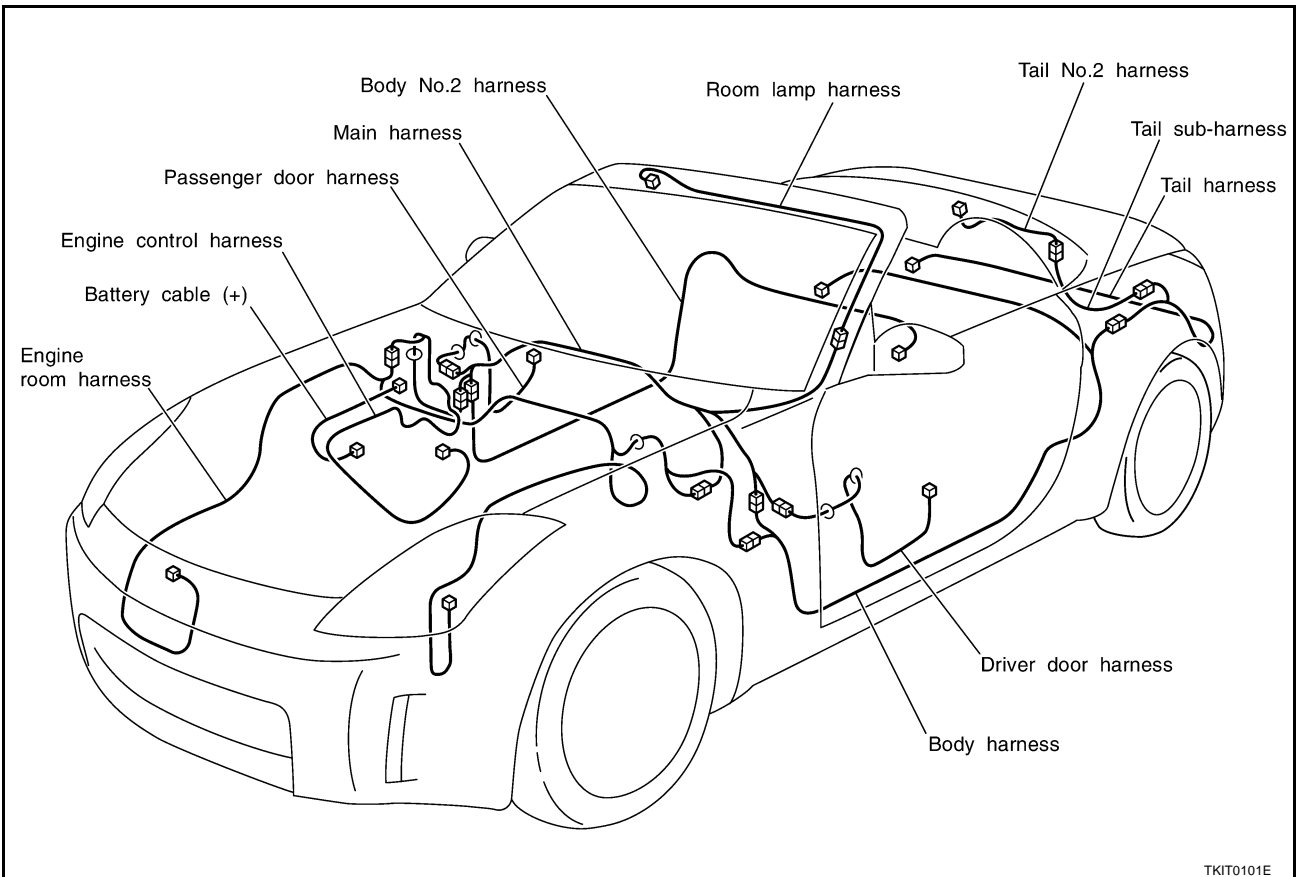

HARNESS

MAIN HARNESS/TYPE 1

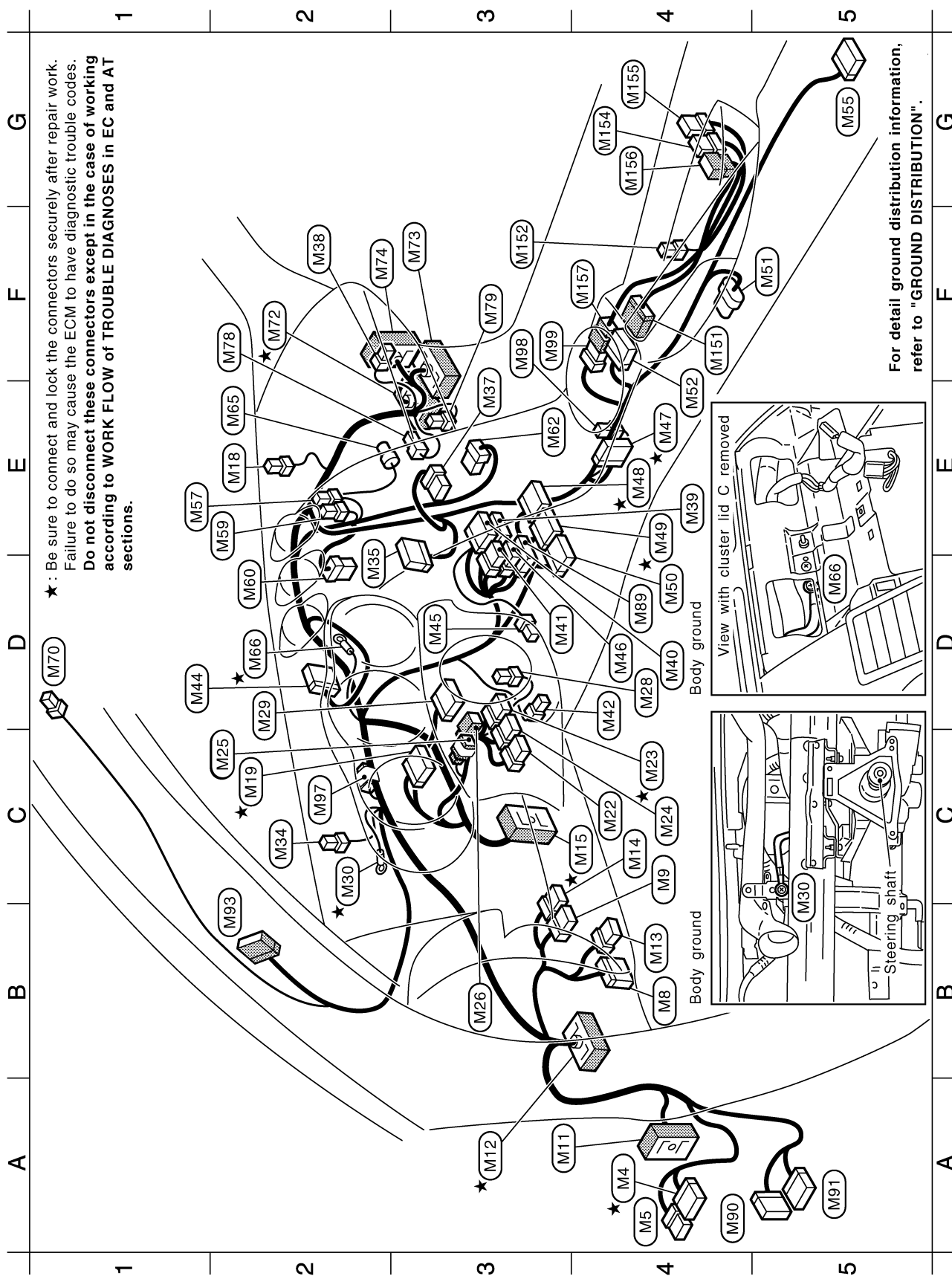

TKIT0547E

HARNESS

A4 ★	(M4)	W/16	: Fuse block (J/B)	(M59)	L/4	: Fuel lid opener relay (For Coupe models)
A4	(M5)	W/8	: Fuse block (J/B)	(M60)	W/6	: To (M254)
B4	(M8)	W/16	: Data link connector	(M62)	W/6	: Blower motor
C4	(M9)	GY/6	: VDC off switch (With VDC system)	(M65)	Y/4	: Front passenger air bag module
		GY/6	: TCS off switch (With TCS without VDC system)	(M66)	—	: Body ground
A3	(M11)	SMJ	: To (D1)	(M70)	W/4	: To (R51)
A3 ★	(M12)	SMJ	: To (B1)	(M72)	SMJ	: To (F102)
B4	(M13)	GY/6	: Fuel lid opener switch	(M73)	SMJ	: To (B101)
C4	(M14)	W/6	: Soft top switch (For Roadster models)			(With navigation system)
C4 ★	(M15)	SMJ	: To (E108)	(M74)	SMJ	: To (D31)
E2	(M18)	B/2	: Sunload sensor	(M78)	W/4	: Remote keyless entry receiver
C2 ★	(M19)	W/24	: Combination meter	(M79)	W/2	: Tire pressure warning check connector
C4	(M22)	W/8	: Steering angle sensor (For VDC system)	(M89)	W/12	: Audio unit (With BOSE system)
C4 ★	(M23)	GY/8	: Combination switch (Spiral cable)	(M90)	W/40	: BCM (Body control module)
C4	(M24)	Y/6	: Combination switch (Spiral cable)	(M91)	B/15	: BCM (Body control module)
C2	(M25)	BR/2	: Key switch	(M93)	W/12	: To (R2)
B3	(M26)	W/2	: Ignition Keyhole illumination	(M97)	-/2	: Resistor
D4	(M28)	W/4	: NATS antenna amp.	(M98)	W/4	: Hazard switch
D2	(M29)	W/16	: Combination switch	(M99)	W/8	: To (M157) (For heated seat)
C2 ★	(M30)	—	: Body ground			
C2	(M34)	BR/2	: Security indicator lamp			
D2	(M35)	GY/24	: Display unit (With navigation system)			
E3	(M37)	W/8	: NAVI switch (With navigation system)			
F2	(M38)	B/2	: Power socket			
E4	(M39)	W/16	: Audio unit (For BOSE system)			
D4	(M40)	W/10	: Audio unit			
D3	(M41)	W/6	: Audio unit			
D4	(M42)	W/2	: In-vehicle sensor			
D1	(M44)	W/12	: Triple meter			
D3	(M45)	BR/2	: Antenna amp. (Via sub-harness)			
D4	(M46)	BR/8	: Audio unit			
E4 ★	(M47)	W/10	: A/T device (For A/T)			
E4 ★	(M48)	GY/20	: Unified meter and A/C amp.			
E4 ★	(M49)	GY/16	: Unified meter and A/C amp.			
D4	(M50)	W/24	: Unified meter and A/C amp.			
F5	(M51)	B/6	: Yaw rate / side G sensor (For VDC system)			
E4	(M52)	W/12	: To (M15)			
G5	(M55)	Y/28	: Air bag diagnosis sensor unit			
E1	(M57)	L/4	: Back-up lamp relay (For A/T)			

Switch sub-harness

F4	(M151)	W/12	: To (M52)
F3	(M152)	W/2	: Cup holder illumination
G4	(M154)	W/6	: Heated seat switch (Driver side)
			(With heated seat)
G4	(M155)	BR/6	: Heated seat switch (Passenger side)
			(With heated seat)
G4	(M156)	W/6	: Not used
F4	(M157)	W/8	: To (M99)
			(For heated seat)

A/C sub-harness

(M251)	W/3	: Not used
(M252)	W/3	: Mode door motor
(M253)	W/3	: Air mix door motor
(M254)	W/6	: To (M60)
(M255)	W/4	: Intake sensor
(M256)	W/3	: Intake door motor

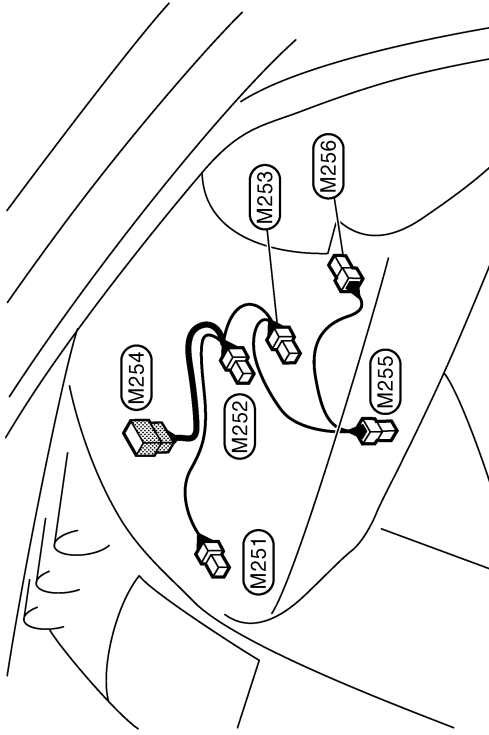

★ : Be sure to connect and lock the connectors securely after repair work.
Failure to do so may cause the ECM to have diagnostic trouble codes.
Do not disconnect these connectors except in the case of working according to WORK FLOW of TROUBLE DIAGNOSES in EC and AT sections.

TKIT0548E

HARNESS

MAIN HARNESS/TYPE 2

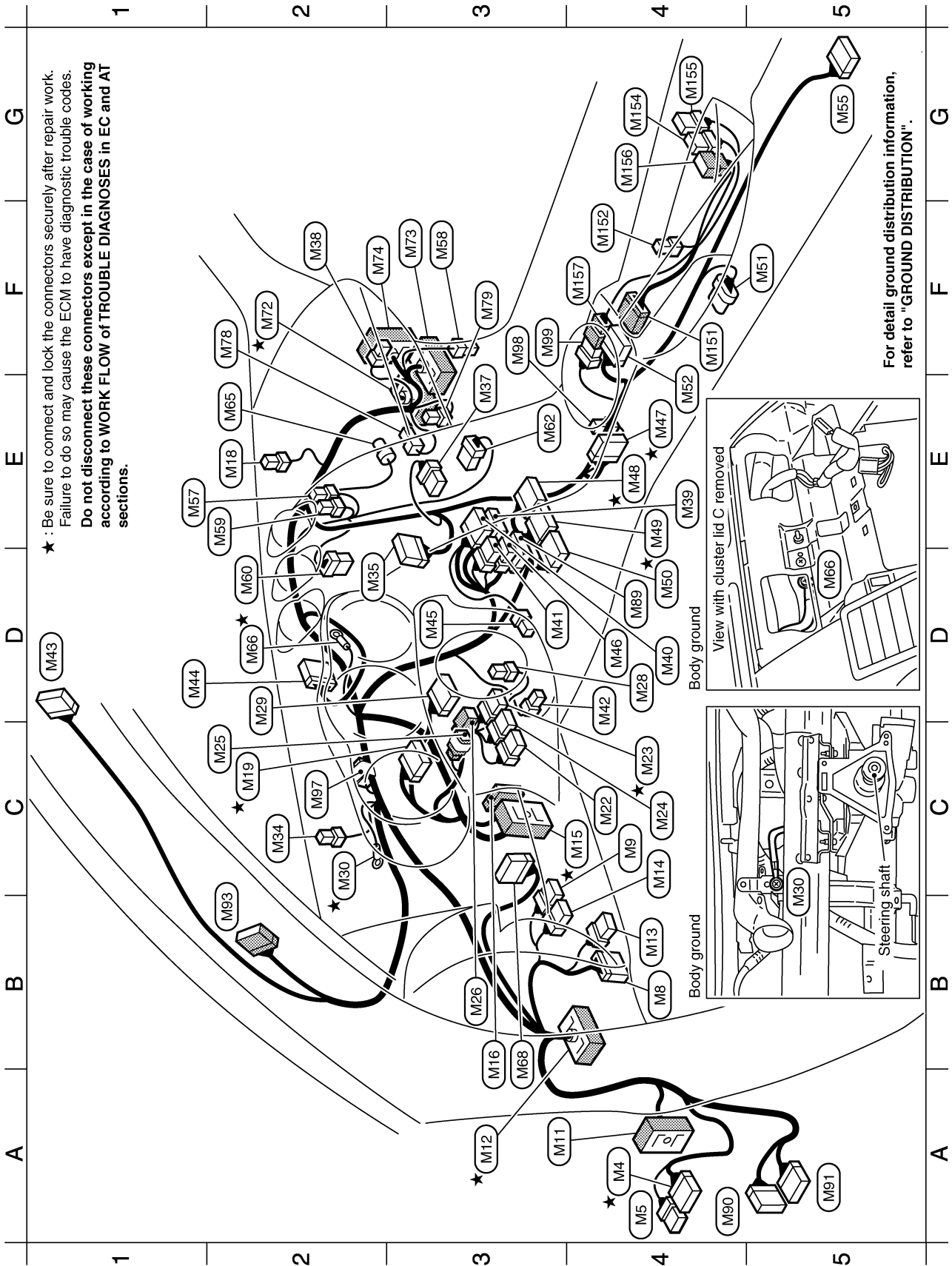

A B C D E F G H I J L M

PG

TKIT0842E

A4	★ (M4)	W/16	:	Fuse block (J/B)	G5	(M55)	Y/28	:	Air bag diagnosis sensor unit	F3	(M98)	W/4	:	Hazard switch
A4	(M5)	W/8	:	Fuse block (J/B)	E1	(M57)	L/4	:	Back-up lamp relay (For A/T)	F3	(M99)	W/8	:	To (M157) (For heated seat)
B4	(M8)	W/16	:	Data link connector	F3	(M58)	W/4	:	To (B112) (With VDC system)					
C4	(M9)	GY/6	:	VDC off switch (With VDC system)	E2	(M59)	L/4	:	Fuel lid opener relay					
		GY/6	:	TCS off switch (Without VDC system)					(For Coupe models)					
A3	(M11)	SMJ	:	To (D1)	D2	(M60)	W/6	:	To (M254)					
A3	★ (M12)	SMJ	:	To (B1)	E3	(M62)	W/6	:	Blower motor	F4	(M151)	W/12	:	To (M52)
B4	(M13)	GY/6	:	Fuel lid opener switch	E2	(M65)	Y/4	:	Front passenger air bag module	F4	(M152)	W/2	:	Cup holder illumination
C4	(M14)	W/6	:	Soft top switch (For Roadster models)	D2	(M66)	—	:	Body ground	G4	(M154)	W/6	:	Heated seat switch
C4	★ (M15)	SMJ	:	To (E108)	B3	(M68)	W/12	:	Power steering control unit					(Driver side)
B3	(M16)	W/16	:	To (E109) (With VDC system)	F2	(M72)	SMJ	:	To (E102)	G4	(M155)	BR/6	:	Heated seat switch
E2	(M18)	B/2	:	Sunload sensor	F3	(M73)	SMJ	:	To (E101)					(Passenger side)
C2	★ (M19)	W/24	:	Combination meter					(With navigation system)	G4	(M156)	W/6	:	Not used
C4	(M22)	W/8	:	Steering angle sensor (With VDC system)	F3	(M73)	SMJ	:	or VDC system)	F4	(M157)	W/8	:	To (M99)
C4	★ (M23)	GY/8	:	Combination switch (Spiral cable)										(For heated seat)
C4	(M24)	Y/6	:	Combination switch (Spiral cable)	F2	(M74)	SMJ	:	To (D31)					
C2	(M25)	BR/2	:	Key switch	F2	(M78)	W/4	:	Remote keyless entry receiver					
B3	(M26)	W/2	:	Ignition Keyhole illumination	F3	(M79)	W/2	:	Tire pressure warning check connector					
D4	(M28)	W/4	:	NATS antenna amp.	D4	(M89)	W/12	:	Audio unit (With BOSE system)					
D2	(M29)	W/16	:	Combination switch	A4	(M90)	W/40	:	BCM (Body control module)					
C2	★ (M30)	—	:	Body ground	A5	(M91)	B/15	:	BCM (Body control module)					
C2	(M34)	BR/2	:	Security indicator lamp	B2	(M93)	W/12	:	To (R2)					
D2	(M35)	GY/24	:	Display unit (With navigation system)	C2	(M97)	—/2	:	Resistor					
E3	(M37)	W/8	:	NAVI switch (With navigation system)										
F2	(M38)	B/2	:	Power socket										
E4	(M39)	W/16	:	Audio unit (With navigation system or BOSE system)										
D4	(M40)	W/10	:	Audio unit										
D3	(M41)	W/6	:	Audio unit										
D4	(M42)	W/2	:	In-vehicle sensor										
D1	(M43)	W/12	:	To (R57)										
D1	(M44)	W/12	:	Triple meter										
D3	(M45)	BR/2	:	Antenna amp. (Via sub-harness)										
D4	(M46)	BR/8	:	Audio unit										
E4	★ (M47)	W/10	:	A/T device (For A/T)										
E4	★ (M48)	GY/20	:	Unified meter and A/C amp.										
E4	★ (M49)	GY/16	:	Unified meter and A/C amp.										
D4	(M50)	W/24	:	Unified meter and A/C amp.										
F5	(M51)	B/6	:	Yaw rate / side G sensor (With VDC system)										
E4	(M52)	W/12	:	To (M151)										

Switch sub-harness

A/C sub-harness

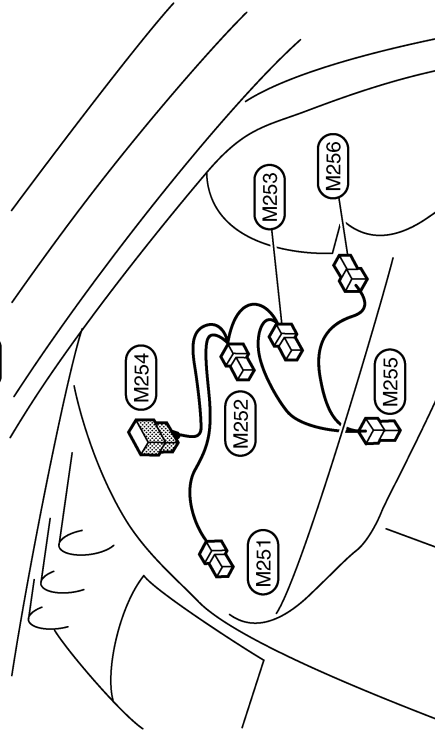

★ : Be sure to connect and lock the connectors securely after repair work.
Failure to do so may cause the ECM to have diagnostic trouble codes.
Do not disconnect these connectors except in the case of working according to WORK FLOW of TROUBLE DIAGNOSES in EC and AT sections.

HARNESS

ENGINE ROOM HARNESS/TYPE 1 Engine Compartment

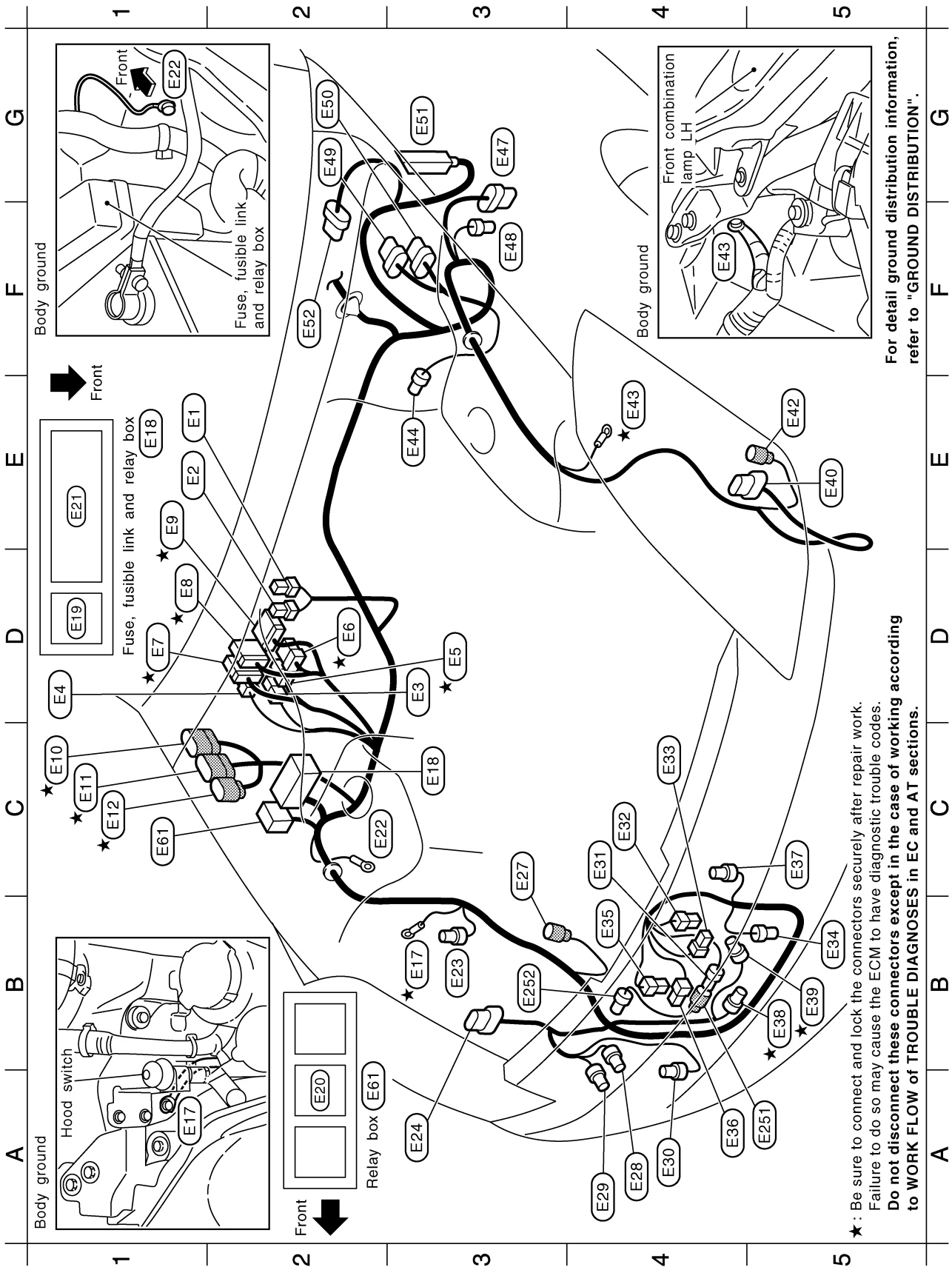

★ : Be sure to connect and lock the connectors securely after repair work. Failure to do so may cause the ECM to have diagnostic trouble codes. Do not disconnect these connectors except in the case of working according to WORK FLOW of TROUBLE DIAGNOSES in EC and AT sections.

For detail ground distribution information, refer to "GROUND DISTRIBUTION".

E1	(E1)	B/2	: Fusible link holder		A4	(E29)	GY/2	: Front washer pump
E1	(E2)	GY/2	: Fusible link holder		A4	(E30)	BR/2	: Washer level sensor
D3	(E3)	B/2	: IPDM E/R (Intelligent power distribution module engine room)		C4	(E31)	B/3	: To (E251)
D1	(E4)	W/4	: IPDM E/R (Intelligent power distribution module engine room)		C4	(E32)	B/1	: Horn (Low)
D3	(E5)	B/4	: IPDM E/R (Intelligent power distribution module engine room)		C4	(E33)	B/1	: Horn (Low)
D2	(E6)	W/6	: IPDM E/R (Intelligent power distribution module engine room)		B5	(E34)	B/2	: Ambient sensor
D1	(E7)	GY/16	: IPDM E/R (Intelligent power distribution module engine room)		B4	(E35)	B/1	: Horn (High)
D1	(E8)	W/12	: IPDM E/R (Intelligent power distribution module engine room)		A4	(E36)	B/1	: Horn (High)
E1	(E9)	W/16	: IPDM E/R (Intelligent power distribution module engine room)		C5	(E37)	Y/2	: Crash zone sensor
C1	(E10)	GY/9	: To (F1)		B5	(E38)	GY/4	: Cooling fan motor-1 (Via sub-harness)
C1	(E11)	GY/10	: To (F2)		B5	(E39)	GY/4	: Cooling fan motor-2 (Via sub-harness)
C1	(E12)	B/8	: To (F3)		E5	(E40)	GY/8	: Front combination lamp LH
B3	(E17)	—	: Body ground		E5	(E42)	B/2	: Front wheel sensor LH
C3	(E18)	—	: Fuse, fusible link and relay box		E4	(E43)	—	: Body ground
D1	(E19)	L/4	: Shift lock relay (With A/T)		E3	(E44)	GY/2	: Brake fluid level switch
A2	(E20)	L/4	: Daytime light relay (For Canada)		G3	(E47)	B/8	: VDC relay box (With VDC system)
E1	(E21)	—	: Fuse and fusible link block		F3	(E48)	B/2	: VDC relay box (With VDC system)
C2	(E22)	—	: Body ground		G2	(E49)	GY/8	: VDC relay box (With VDC system)
B3	(E23)	GY/2	: Hood switch		G2	(E50)	B/8	: VDC relay box (With VDC system)
A3	(E24)	GY/8	: Front combination lamp RH		G3	(E51)	SMJ	: ABS actuator and electric unit (Without VDC system)
C3	(E27)	GY/2	: Front wheel sensor RH		F2	(E52)	GY/5	: Front wiper motor
A4	(E28)	GY/2	: Rear washer pump		C1	(E61)	—	: Relay box (For Canada)

Sub-harness

A5	(E251)	B/3	: To (E31)
B3	(E252)	B/3	: Refrigerant pressure sensor

★ : Be sure to connect and lock the connectors securely after repair work.
 Failure to do so may cause the ECM to have diagnostic trouble codes.
Do not disconnect these connectors except in the case of working according to WORK FLOW of TROUBLE DIAGNOSES in EC and AT sections.

Passenger Compartment

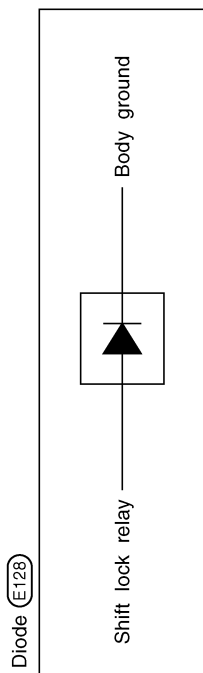

- ★ (E101) W/8 : Fuse block (J/B)
- (E102) W/6 : Fuse block (J/B)
- (E103) B/1 : Fuse block (J/B)
- (E104) B/2 : Fuse block (J/B)
- ★ (E106) W/18 : To (B2)
- (E107) W/6 : To (B3)
- ★ (E108) SMJ : To (M15)
- ★ (E110) BR/2 : ASCD brake switch
- ★ (E111) W/4 : Stop lamp switch
- ★ (E113) GY/6 : Accelerator pedal position sensor
- (E118) SMJ : VDC / TCS / ABS control unit
(With VDC system)
- (E119) W/6 : Ignition switch
- (E121) L/2 : Clutch interlock switch (With M/T)
- ★ (E122) L/2 : ASCD clutch switch (With M/T)
- (E123) BR/2 : Microphone
- (E126) BR/2 : Jumping connector
(With VDC system)
- (E127) BR/2 : Jumping connector
(With VDC system)
- (E128) W/2 : Diode (With A/T)

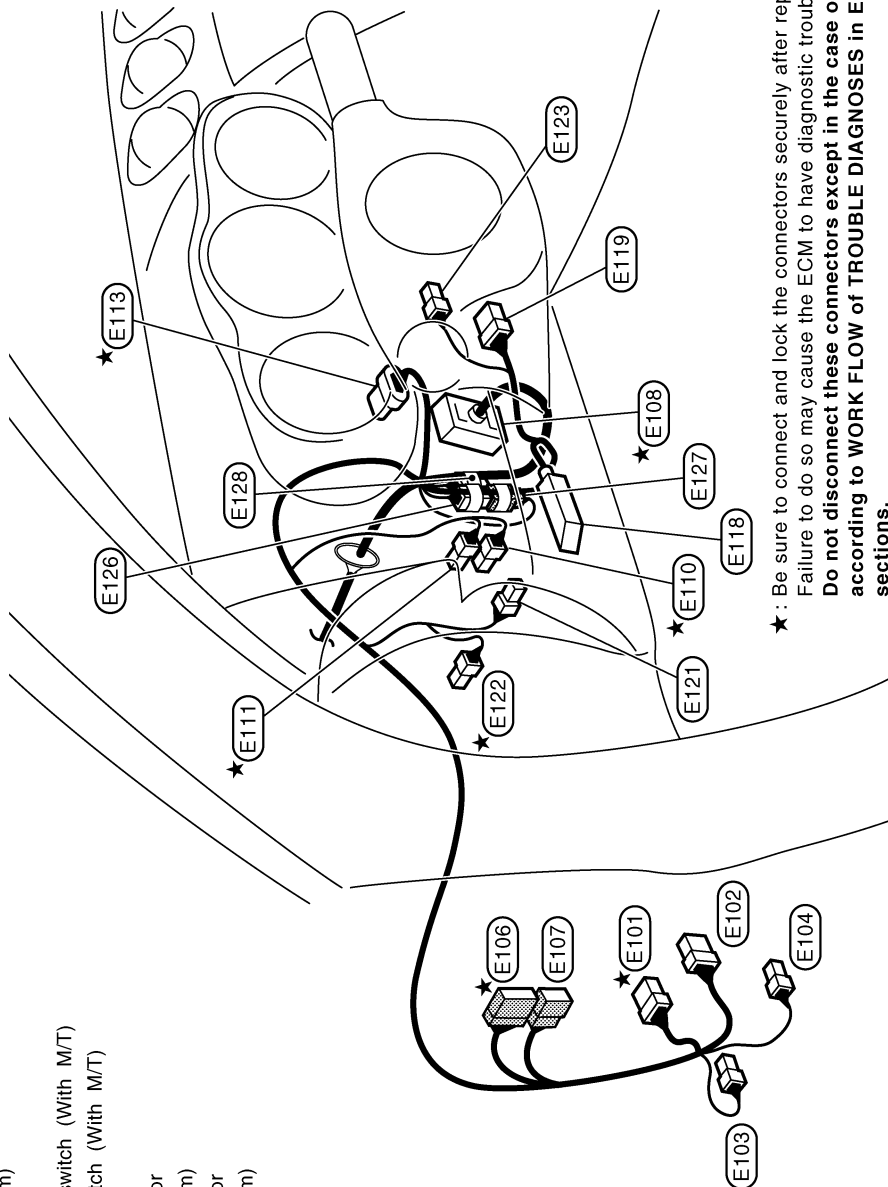

★ : Be sure to connect and lock the connectors securely after repair work.
Failure to do so may cause the ECM to have diagnostic trouble codes.
Do not disconnect these connectors except in the case of working according to WORK FLOW of TROUBLE DIAGNOSES in EC and AT sections.

A
B
C
D
E
F
G
H
I
J
PG
L
M

HARNESS

Battery Cable

- (E201) : Fusible link holder
- (E202) : Alternator (B)
- (E203) : Starter motor
- (E211) : Alternator (E)
- (E212) : Body ground
- (E213) : Engine ground

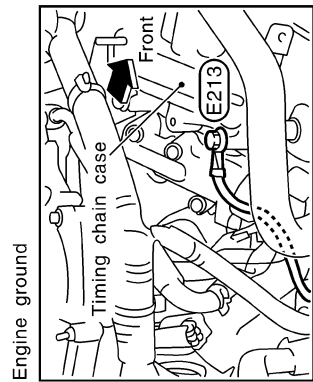
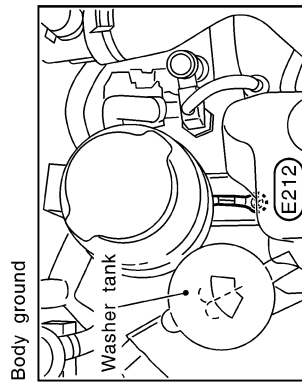
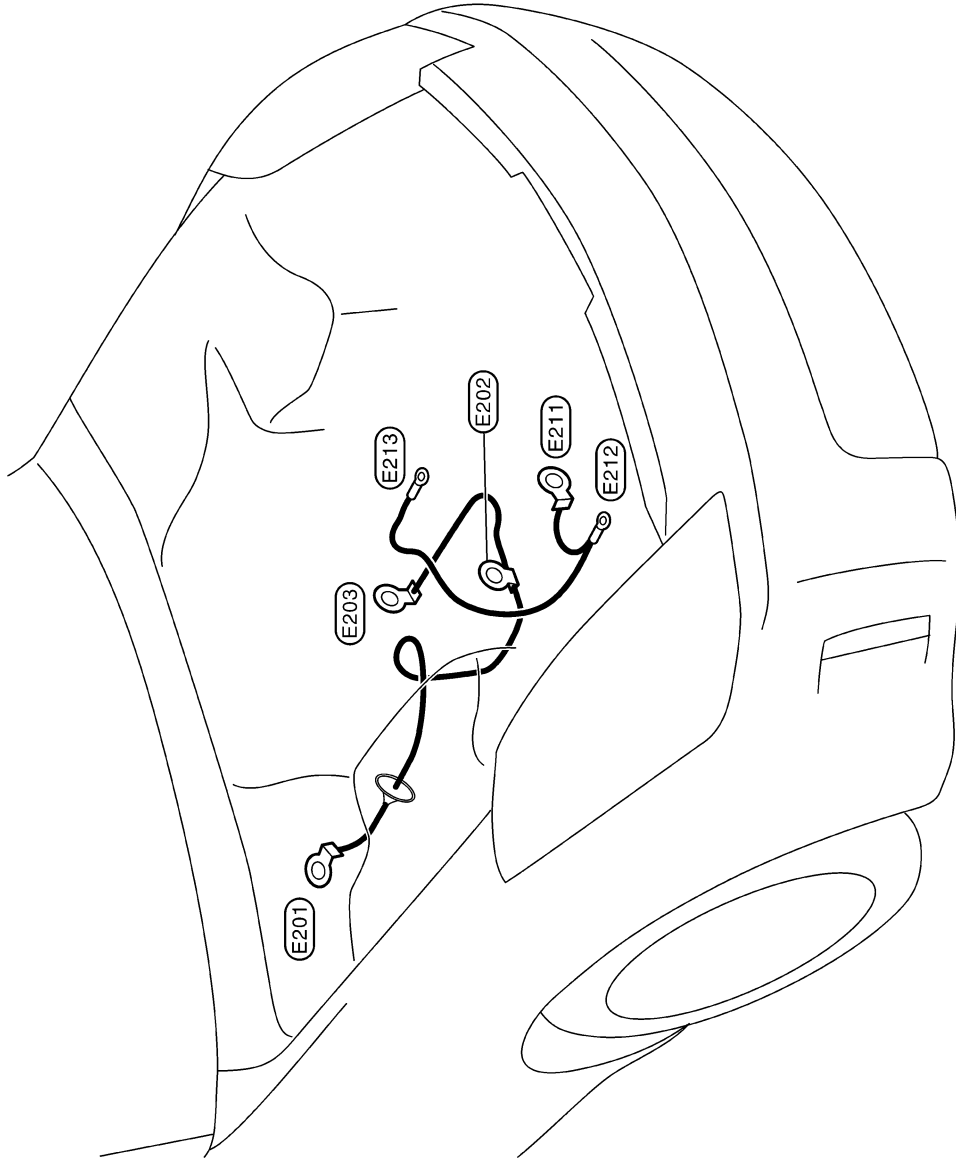

For detail ground distribution information, refer to "GROUND DISTRIBUTION".

CKIT0202E

HARNESS

ENGINE ROOM HARNESS/TYPE 2 Engine Compartment

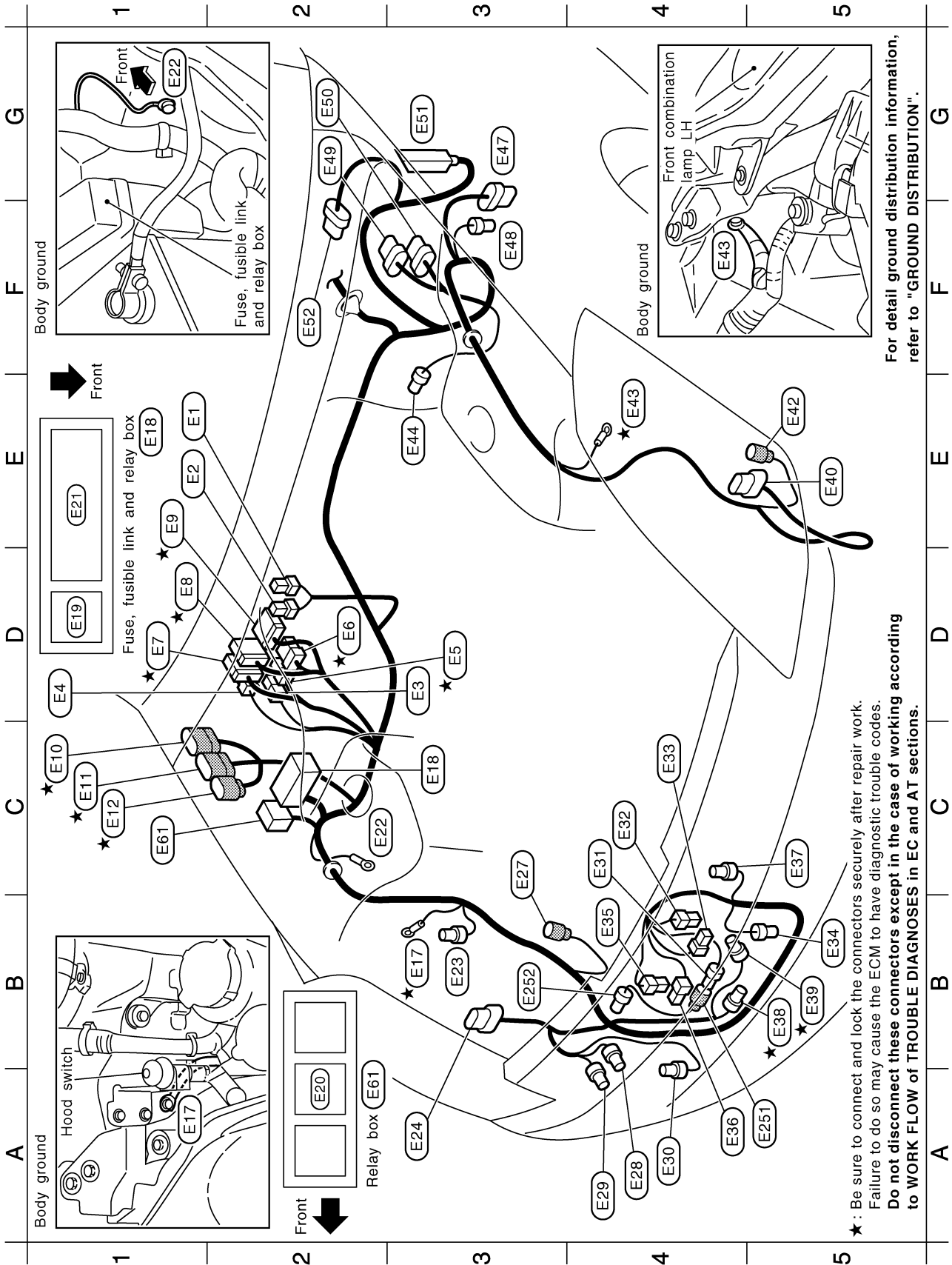

★ : Be sure to connect and lock the connectors securely after repair work. Failure to do so may cause the ECM to have diagnostic trouble codes. Do not disconnect these connectors except in the case of working according to WORK FLOW of TROUBLE DIAGNOSES in EC and AT sections.

For detail ground distribution information, refer to "GROUND DISTRIBUTION".

A B C D E F G H I J K L M N O P Q R S T U V W X Y Z

PG

HARNESSES

E1	(E1)	B/2	:	Fusible link holder	A4	(E29)	GY/2	:	Front washer pump
E1	(E2)	GY/2	:	Fusible link holder	A4	(E30)	BR/2	:	Washer level sensor
D3	(E3)	B/2	:	IPDM E/R (Intelligent power distribution module engine room)	C4	(E31)	B/3	:	To (E25)
D1	(E4)	W/4	:	IPDM E/R (Intelligent power distribution module engine room)	C4	(E32)	B/1	:	Horn (Low)
D3	(E5)	B/4	:	IPDM E/R (Intelligent power distribution module engine room)	C4	(E33)	B/1	:	Horn (Low)
D2	(E6)	W/6	:	IPDM E/R (Intelligent power distribution module engine room)	B5	(E34)	B/2	:	Ambient sensor
D1	(E7)	GY/16	:	IPDM E/R (Intelligent power distribution module engine room)	B4	(E35)	B/1	:	Horn (High)
D1	(E8)	W/12	:	IPDM E/R (Intelligent power distribution module engine room)	A4	(E36)	B/1	:	Horn (High)
E1	(E9)	W/16	:	IPDM E/R (Intelligent power distribution module engine room)	C5	(E37)	Y/2	:	Crash zone sensor
C1	(E10)	GY/9	:	To (F1)	B5	(E38)	GY/4	:	Cooling fan motor-1 (Via sub-harness)
C1	(E11)	GY/10	:	To (F2)	B5	(E39)	GY/4	:	Cooling fan motor-2 (Via sub-harness)
C1	(E12)	B/8	:	To (F3)	E5	(E40)	GY/8	:	Front combination lamp LH
B3	(E17)	—	:	Body ground	E5	(E42)	B/2	:	Front wheel sensor LH
C3	(E18)	—	:	Fuse, fusible link and relay box	E4	(E43)	—	:	Body ground
D1	(E19)	L/4	:	Shift lock relay (With A/T)	E3	(E44)	GY/2	:	Brake fluid level switch
A2	(E20)	L/4	:	Daytime light relay (For Canada)	G3	(E47)	B/8	:	VDC relay box (With VDC system)
E1	(E21)	—	:	Fuse and fusible link block	F3	(E48)	B/2	:	VDC relay box (With VDC system)
C2	(E22)	—	:	Body ground	G2	(E49)	GY/8	:	VDC actuator (With VDC system)
B3	(E23)	GY/2	:	Hood switch	G2	(E50)	B/8	:	VDC actuator (With VDC system)
A3	(E24)	GY/8	:	Front combination lamp RH	G3	(E51)	SMJ	:	ABS actuator and electric unit (Without VDC system)
C3	(E27)	GY/2	:	Front wheel sensor RH	F2	(E52)	GY/5	:	Front wiper motor
A4	(E28)	GY/2	:	Rear washer pump	C1	(E61)	—	:	Relay box (For Canada)

Sub-harness

A5	(E251)	B/3	:	To (E31)
B3	(E252)	B/3	:	Refrigerant pressure sensor

★ : Be sure to connect and lock the connectors securely after repair work.
 Failure to do so may cause the ECM to have diagnostic trouble codes.
Do not disconnect these connectors except in the case of working according to WORK FLOW of TROUBLE DIAGNOSES in EC and AT sections.

HARNESS

Passenger Compartment

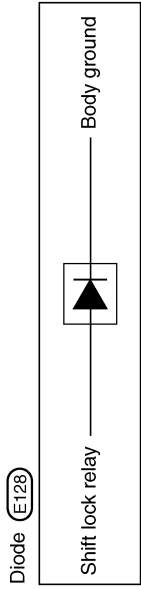

- ★ (E101) : Fuse block (J/B)
- (E102) : Fuse block (J/B)
- (E103) : Fuse block (J/B)
- (E104) : Fuse block (J/B)
- ★ (E106) : To (E2)
- (E107) : To (E3)
- ★ (E108) : To (M15)
- (E109) : To (M16) (With VDC system)
- ★ (E110) : ASCD brake switch
- ★ (E111) : Stop lamp switch
- ★ (E113) : Accelerator pedal position sensor
- (E119) : Ignition switch
- (E121) : Clutch interlock switch (With M/T)
- ★ (E122) : ASCD clutch switch (With M/T)
- (E123) : Microphone
- (E128) : Diode (With A/T) (if so equipped)

- W/8
- W/6
- B/1
- B/2
- W/18
- W/6
- SMJ
- W/16
- BR/2
- W/4
- GY/6
- W/6
- L/2
- L/2
- BR/2
- W/2

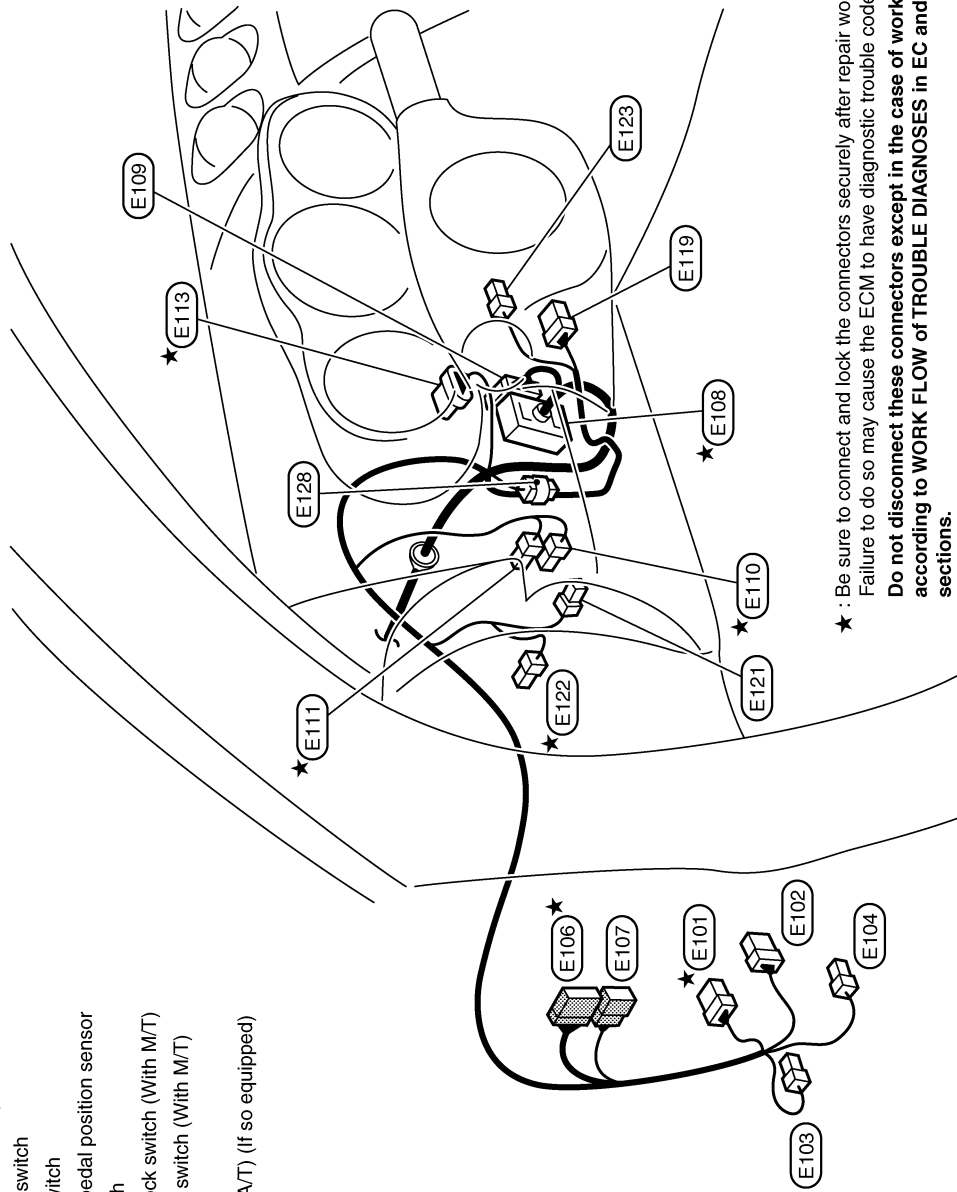

★ : Be sure to connect and lock the connectors securely after repair work.
 Failure to do so may cause the ECM to have diagnostic trouble codes.
 Do not disconnect these connectors except in the case of working according to WORK FLOW of TROUBLE DIAGNOSES in EC and AT sections.

A
B
C
D
E
F
G
H
I
J
L
M

PG

TKIT0906E

HARNESS

Battery Cable

- (E201) : Fusible link holder
- (E202) : Alternator (B)
- (E203) : Starter motor
- (E211) : Alternator (E)
- (E212) : Body ground
- (E213) : Engine ground

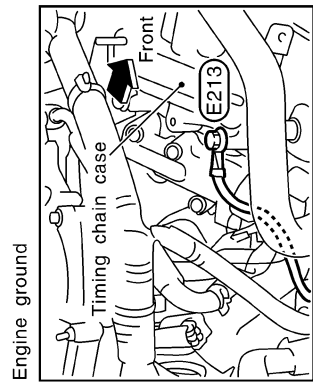
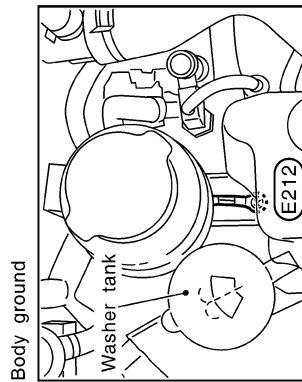
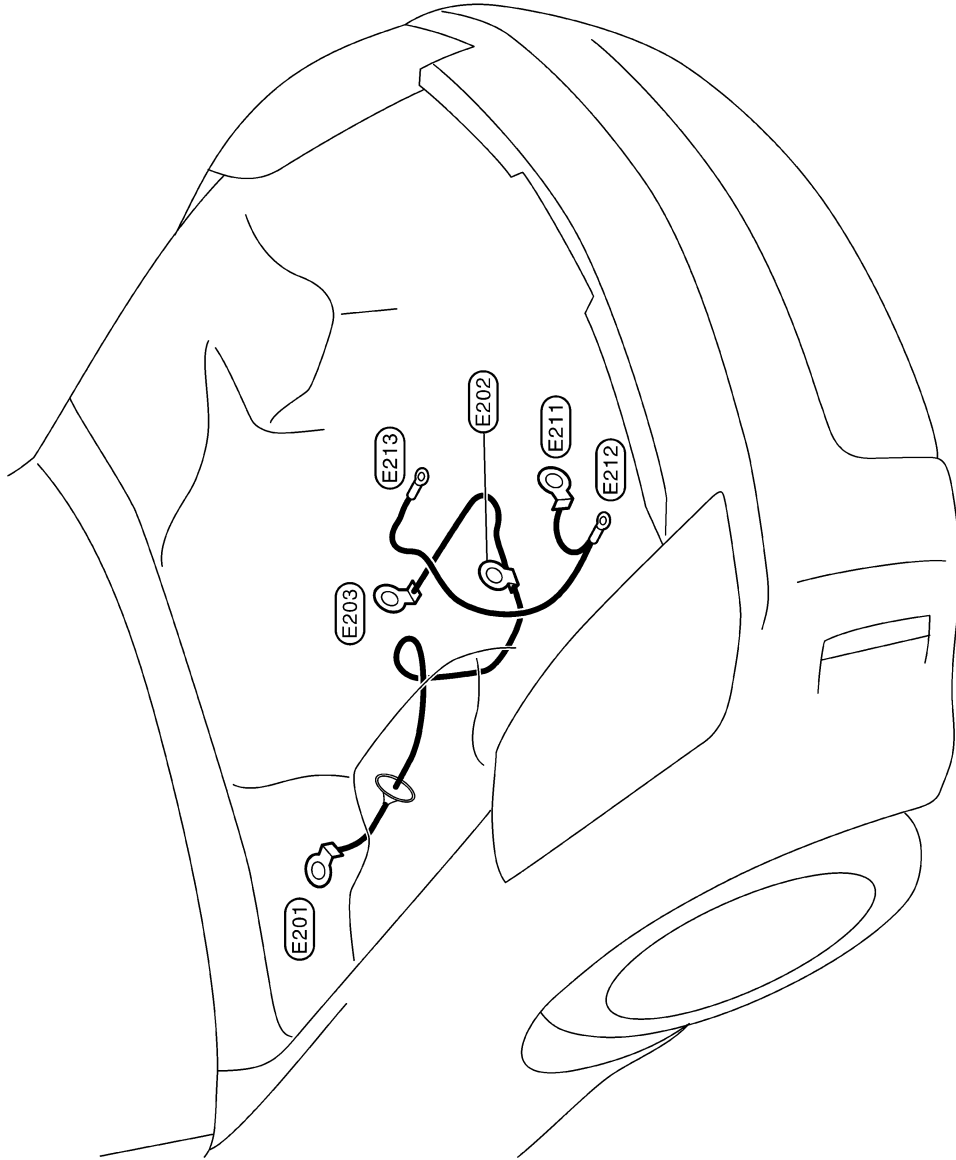

For detail ground distribution information, refer to "GROUND DISTRIBUTION".

CKIT0202E

HARNESS

ENGINE CONTROL HARNESS/TYPE 1 Engine Compartment

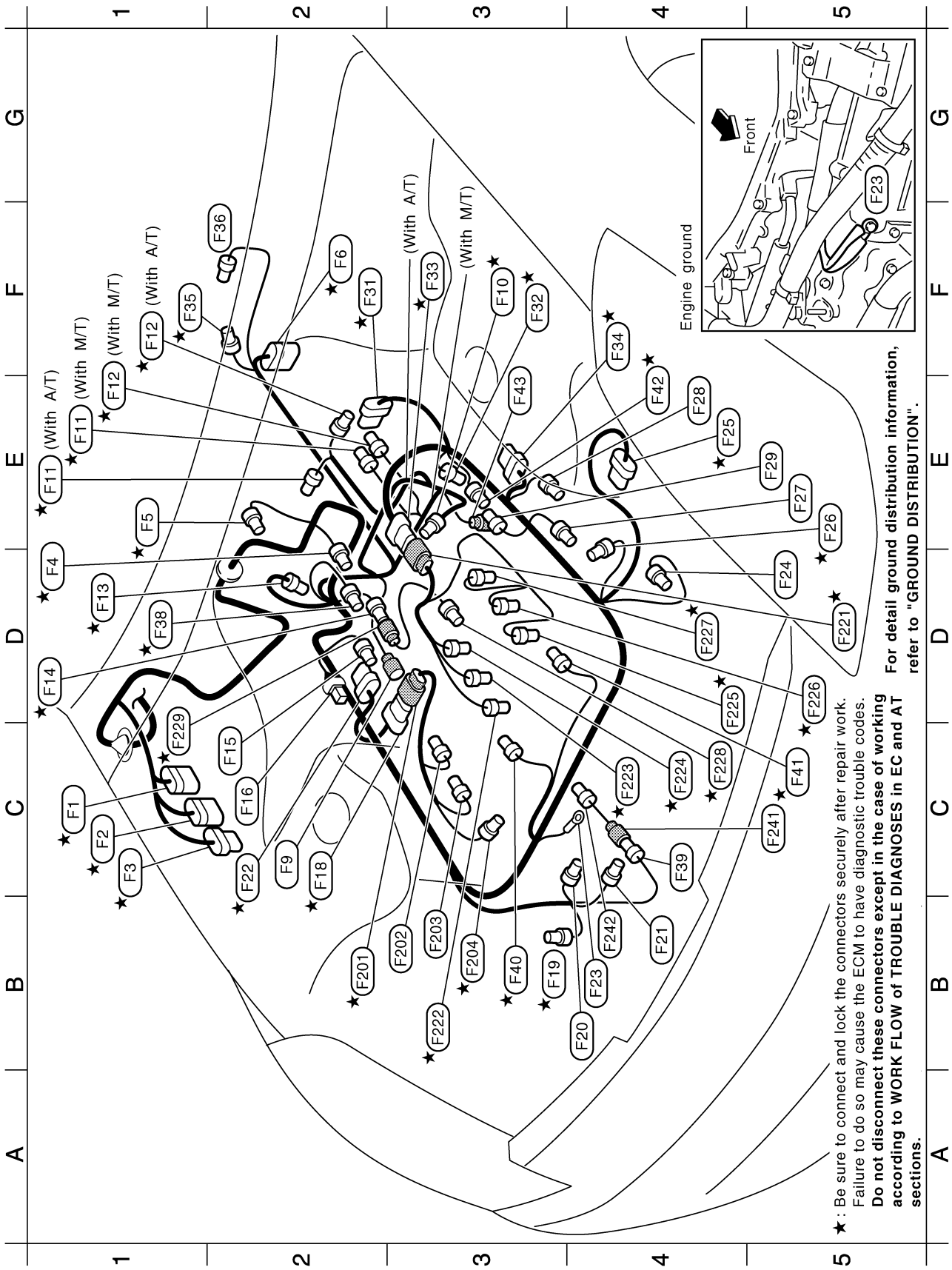

★ : Be sure to connect and lock the connectors securely after repair work.
Failure to do so may cause the ECM to have diagnostic trouble codes.
Do not disconnect these connectors except in the case of working
according to WORK FLOW of TROUBLE DIAGNOSES in EC and AT
sections.

For detail ground distribution information,
refer to "GROUND DISTRIBUTION".

A
B
C
D
E
F
G
H
I
J
K
L
M

PG

Engine control sub-harness-1

B2 ★ (F201) L/6 : To (F18)
 B3 ★ (F202) GY/3 : Ignition coil No.3 (With power transistor)
 B3 ★ (F203) GY/3 : Ignition coil No.1 (With power transistor)
 B3 ★ (F204) G/2 : Intake valve timing control solenoid valve (Bank 1)

Engine control sub-harness-2

D5 ★ (F221) G/8 : To (F33)
 B3 ★ (F222) GY/2 : Fuel injector No.1
 C4 ★ (F223) GY/2 : Fuel injector No.3
 C4 ★ (F224) GY/2 : Fuel injector No.5
 D4 ★ (F225) GY/2 : Fuel injector No.2
 D5 ★ (F226) GY/2 : Fuel injector No.4
 D4 ★ (F227) GY/2 : Fuel injector No.6
 C4 ★ (F228) L/2 : Knock sensor
 C1 ★ (F229) SB/2 : To (F14)

Engine control sub-harness-3 (With M/T)

C5 (F241) BR/2 : To (F39)
 B4 (F242) GY/2 : Engine oil temperature sensor

C1 ★ (F1)	GY/9	: To (E10)	
C1 ★ (F2)	GY/10	: To (E11)	
C1 ★ (F3)	B/8	: To (E12)	
D1 ★ (F4)	G/3	: Camshaft position sensor (PHASE) (Bank 1)	
E1 ★ (F5)	GY/2	: EVAP canister purge volume control solenoid valve	
F2 ★ (F6)	GY/10	: A/T assembly (With A/T)	
C2 (F9)	GY/1	: Starter motor	
F3 ★ (F10)	B/3	: Crankshaft position sensor (POS)	
E1 ★ (F11)	B/4	: Heated oxygen sensor 2 (Bank 1)	
E1,F1 ★ (F12)	GY/4	: Heated oxygen sensor 2 (Bank 2)	
D1 ★ (F13)	GY/2	: Engine coolant temperature sensor	
D1 ★ (F14)	B/2	: To (F229)	
C2 (F15)	GY/3	: Ignition coil No.5 (With power transistor)	
C2 (F16)	W/2	: Condenser	
C2 ★ (F18)	B/6	: To (F201)	
B3 ★ (F19)	B/3	: Power steering pressure sensor	
B4 (F20)	GY/2	: Alternator (S, L)	
B4 (F21)	B/3	: Oil pressure sensor	
C2 ★ (F22)	B/6	: Air fuel ratio (A/F) sensor 1 (Bank 1)	
B4 (F23)	—	: Engine ground	
D5 (F24)	B/1	: Compressor	
E4 ★ (F25)	B/6	: Mass air flow sensor	
E5 ★ (F26)	GY/2	: Intake valve timing control solenoid valve (Bank 2)	
E5 (F27)	GY/3	: Ignition coil No.2 (With power transistor)	
E4 (F28)	GY/3	: Ignition coil No.4 (With power transistor)	
E5 (F29)	GY/3	: Ignition coil No.6 (With power transistor)	
F2 ★ (F31)	GY/6	: Electric throttle control actuator	
F3 ★ (F32)	B/3	: Camshaft position sensor (PHASE) (Bank 2)	
F3 ★ (F33)	GY/8	: To (F221)	
F4 ★ (F34)	B/6	: Air fuel ratio (A/F) sensor 1 (Bank 2)	
F1 ★ (F35)	B/2	: Park/Neutral position switch (With M/T)	
F2 (F36)	B/2	: Back-up lamp switch (With M/T)	
D1 ★ (F38)	B/3	: Exhaust valve timing control position sensor (Bank 1) (With M/T)	
C4 (F39)	BR/2	: To (F241) (With M/T)	
B3 ★ (F40)	G/4	: Exhaust valve timing control magnet retarder (Bank 1) (With M/T)	
C5 ★ (F41)	L/4	: Exhaust valve timing control magnet retarder (Bank 2) (With M/T)	
E4 ★ (F42)	G/3	: Exhaust valve timing control position sensor (Bank 2) (With M/T)	
E3 (F43)	GY/2	: Power steering solenoid valve	

★ : Be sure to connect and lock the connectors securely after repair work.
 Failure to do so may cause the ECM to have diagnostic trouble codes.
Do not disconnect these connectors except in the case of working according to WORK FLOW of TROUBLE DIAGNOSES in EC and AT sections.

HARNESSES

Passenger Compartment

Engine control harness

- ★ (F101) SMJ : ECM
- ★ (F102) SMJ : To (M72)
- ★ (F103) W/4 : To (F151)
- ★ (F104) W/8 : Power steering control unit

Earth sub-harness

- ★ (F151) W/4 : To (F103)
- ★ (F152) — : Body ground

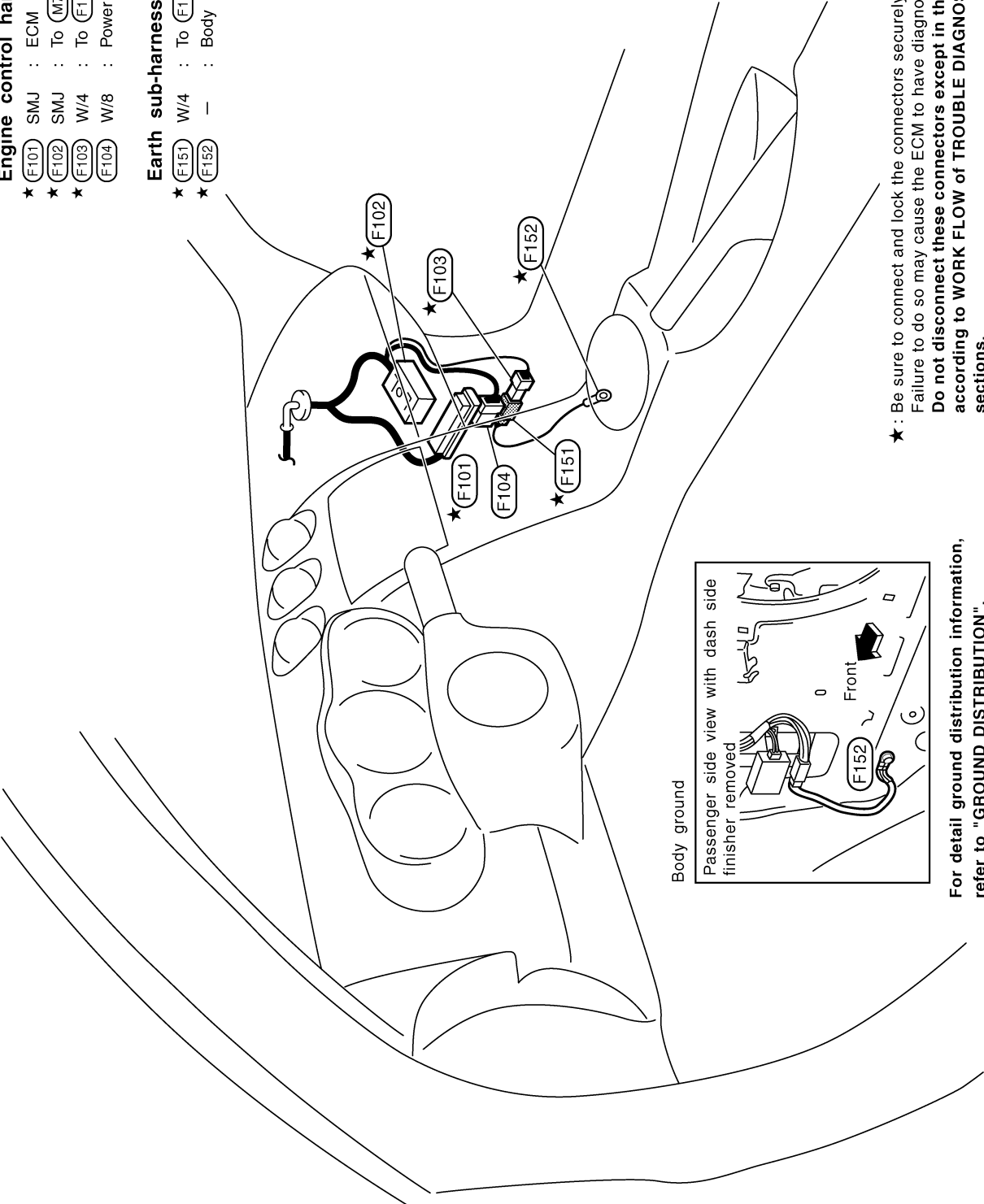

★ : Be sure to connect and lock the connectors securely after repair work. Failure to do so may cause the ECM to have diagnostic trouble codes. Do not disconnect these connectors except in the case of working according to WORK FLOW of TROUBLE DIAGNOSES in EC and AT sections.

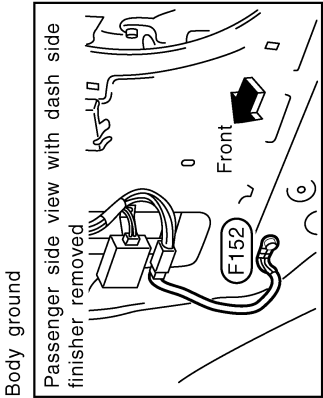

For detail ground distribution information, refer to "GROUND DISTRIBUTION".

A
B
C
D
E
F
G
H
I
J
L
M

HARNESS

ENGINE CONTROL HARNESS/TYPE 2

Engine Compartment

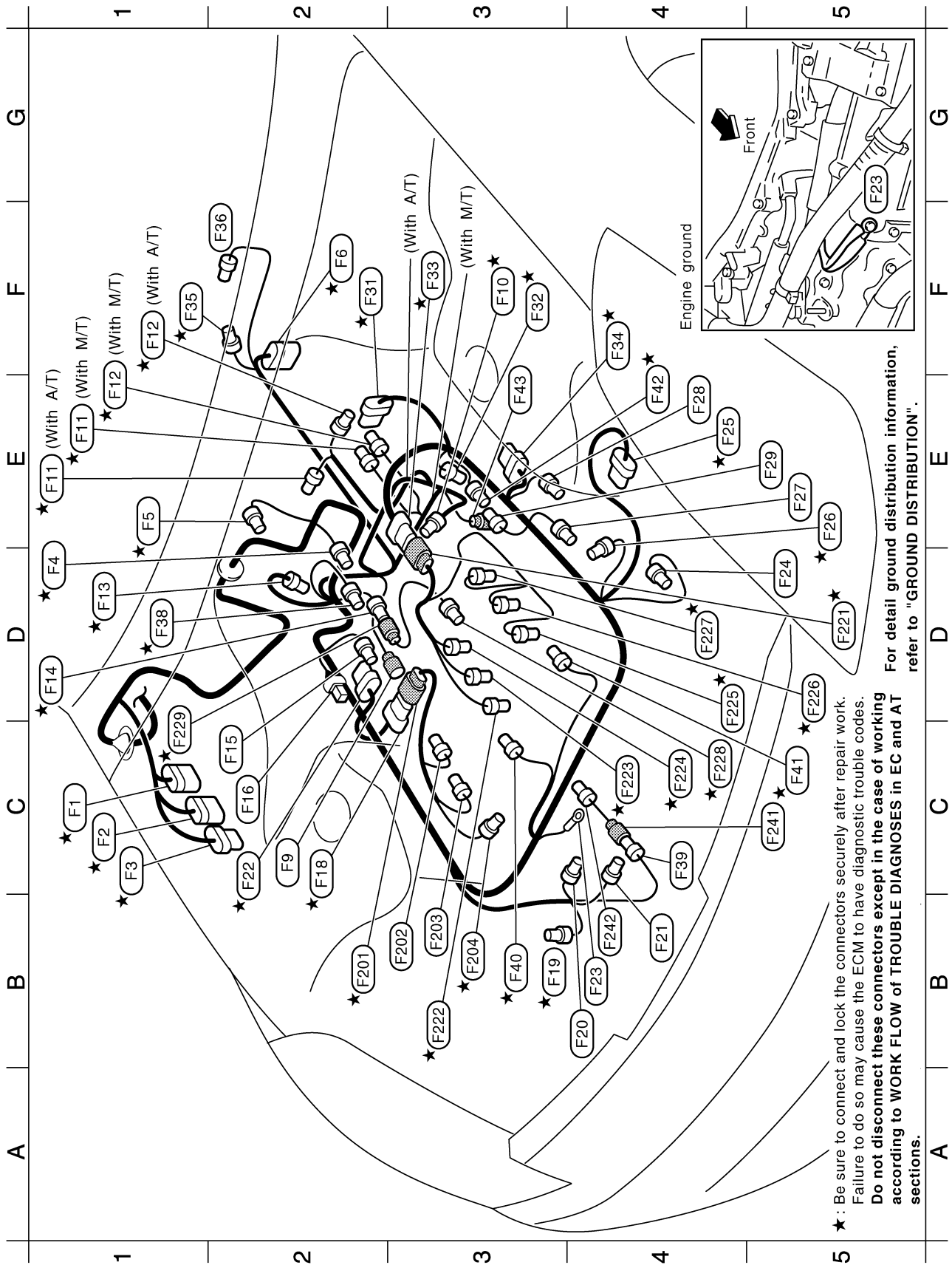

★ : Be sure to connect and lock the connectors securely after repair work. Failure to do so may cause the ECM to have diagnostic trouble codes. Do not disconnect these connectors except in the case of working according to WORK FLOW of TROUBLE DIAGNOSES in EC and AT sections.

For detail ground distribution information, refer to "GROUND DISTRIBUTION".

Engine control sub-harness-1

- B2 ★ (F201) L/6 : To (F18)
- B3 ★ (F202) GY/3 : Ignition coil No.3 (With power transistor)
- B3 ★ (F203) GY/3 : Ignition coil No.1 (With power transistor)
- B3 ★ (F204) G/2 : Intake valve timing control solenoid valve (Bank 1)

Engine control sub-harness-2

- D5 ★ (F221) G/8 : To (F33)
- B3 ★ (F222) GY/2 : Fuel injector No.1
- C4 ★ (F223) GY/2 : Fuel injector No.3
- C4 ★ (F224) GY/2 : Fuel injector No.5
- D4 ★ (F225) GY/2 : Fuel injector No.2
- D5 ★ (F226) GY/2 : Fuel injector No.4
- D4 ★ (F227) GY/2 : Fuel injector No.6
- C4 ★ (F228) L/2 : Knock sensor
- C1 ★ (F229) SB/2 : To (F14)

Engine control sub-harness-3 (With M/T)

- C5 (F241) BR/2 : To (F39)
- B4 (F242) GY/2 : Engine oil temperature sensor

- C1 ★ (F1) GY/9 : To (E10)
- C1 ★ (F2) GY/10 : To (E11)
- C1 ★ (F3) B/8 : To (E12)
- D1 ★ (F4) G/3 : Camshaft position sensor (PHASE) (Bank 1)
- E1 ★ (F5) GY/2 : EVAP canister purge volume control solenoid valve
- F2 ★ (F6) GY/10 : A/T assembly (With A/T)
- C2 (F9) GY/1 : Starter motor
- F3 ★ (F10) B/3 : Crankshaft position sensor (POS)
- E1 ★ (F11) B/4 : Heated oxygen sensor 2 (Bank 1)
- E1,F1 ★ (F12) GY/4 : Heated oxygen sensor 2 (Bank 2)
- D1 ★ (F13) GY/2 : Engine coolant temperature sensor
- D1 ★ (F14) B/2 : To (F229)
- C2 (F15) GY/3 : Ignition coil No.5 (With power transistor)
- C2 (F16) W/2 : Condenser
- C2 ★ (F18) B/6 : To (F201)
- B3 ★ (F19) B/3 : Power steering pressure sensor
- B4 (F20) GY/2 : Alternator (S, L)
- B4 (F21) B/3 : Oil pressure sensor
- C2 ★ (F22) B/6 : Air fuel ratio (A/F) sensor 1 (Bank 1)
- B4 (F23) — : Engine ground
- D5 (F24) B/1 : Compressor
- E4 ★ (F25) B/6 : Mass air flow sensor
- E5 ★ (F26) GY/2 : Intake valve timing control solenoid valve (Bank 2)
- E5 (F27) GY/3 : Ignition coil No.2 (With power transistor)
- E4 (F28) GY/3 : Ignition coil No.4 (With power transistor)
- E5 (F29) GY/3 : Ignition coil No.6 (With power transistor)
- F2 ★ (F31) GY/6 : Electric throttle control actuator
- F3 ★ (F32) B/3 : Camshaft position sensor (PHASE) (Bank 2)
- F3 ★ (F33) GY/8 : To (F221)
- F4 ★ (F34) B/6 : Air fuel ratio (A/F) sensor 1 (Bank 2)
- F1 ★ (F35) B/2 : Park/Neutral position switch (With M/T)
- F2 (F36) B/2 : Back-up lamp switch (With M/T)
- D1 ★ (F38) B/3 : Exhaust valve timing control position sensor (Bank 1) (With M/T)
- C4 (F39) BR/2 : To (F241) (With M/T)
- B3 ★ (F40) G/4 : Exhaust valve timing control magnet retarder (Bank 1) (With M/T)
- C5 ★ (F41) L/4 : Exhaust valve timing control magnet retarder (Bank 2) (With M/T)
- E4 ★ (F42) G/3 : Exhaust valve timing control position sensor (Bank 2) (With M/T)
- E3 (F43) GY/2 : Power steering solenoid valve

★ : Be sure to connect and lock the connectors securely after repair work. Failure to do so may cause the ECM to have diagnostic trouble codes. **Do not disconnect these connectors except in the case of working according to WORK FLOW of TROUBLE DIAGNOSES in EC and AT sections.**

HARNESS

Passenger Compartment

Engine control harness

- ★ (F101) SMJ : ECM
- ★ (F102) SMJ : To (M72)
- ★ (F103) W/4 : To (F151) (*2)
- W/4 : To (B113) (*1)

Earth sub-harness (*2)

- ★ (F151) W/4 : To (F103)
- ★ (F152) - : Body ground

*1 : With VDC system or navigation system
 *2 : Without VDC system and navigation system

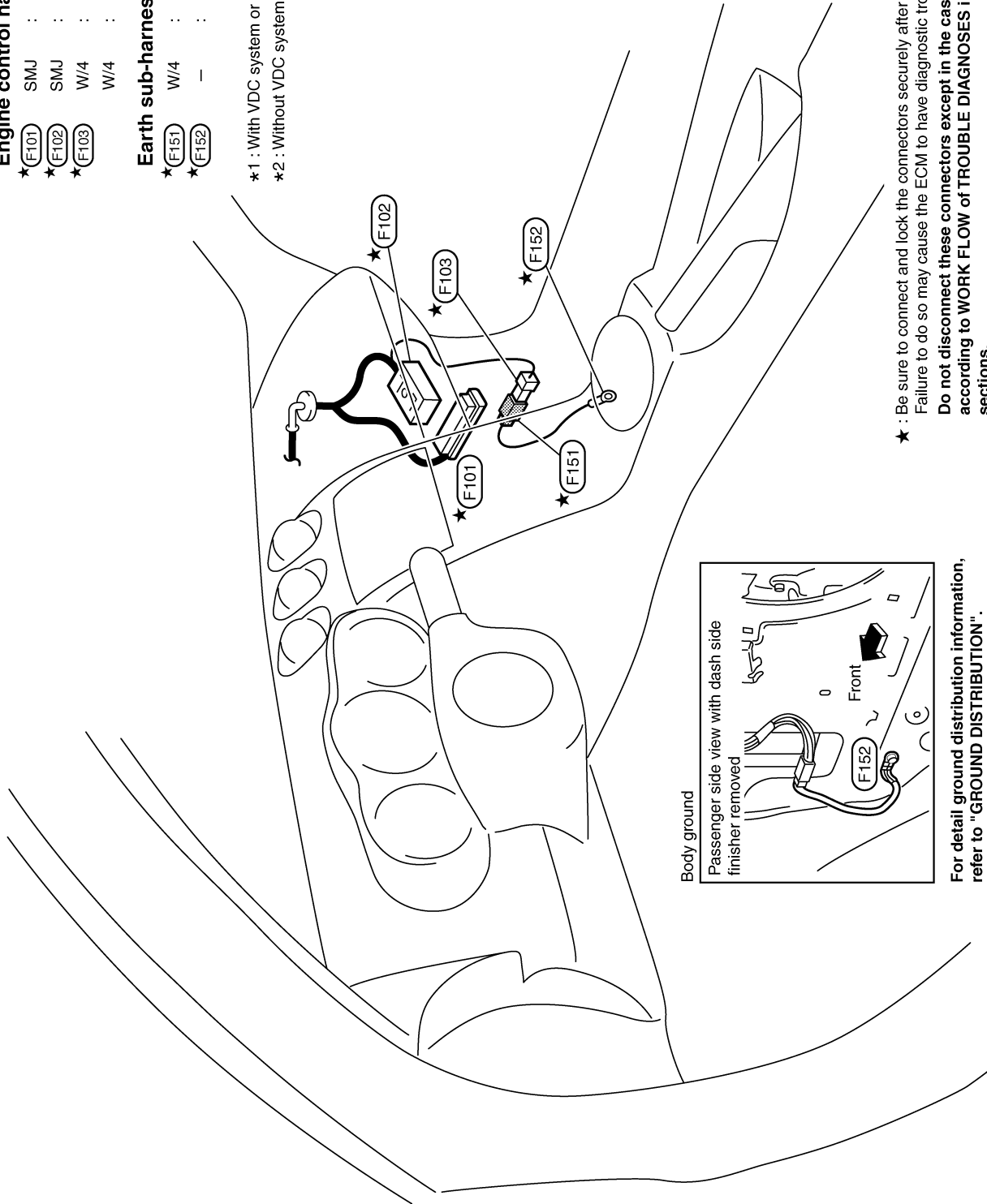

★ : Be sure to connect and lock the connectors securely after repair work. Failure to do so may cause the ECM to have diagnostic trouble codes. Do not disconnect these connectors except in the case of working according to WORK FLOW of TROUBLE DIAGNOSES in EC and AT sections.

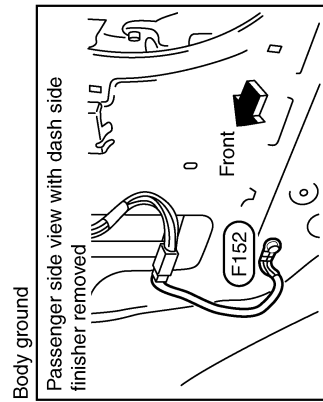

For detail ground distribution information, refer to "GROUND DISTRIBUTION".

TKIT0846E

HARNESS

BODY HARNESS/TYPE 1

Coupe Models

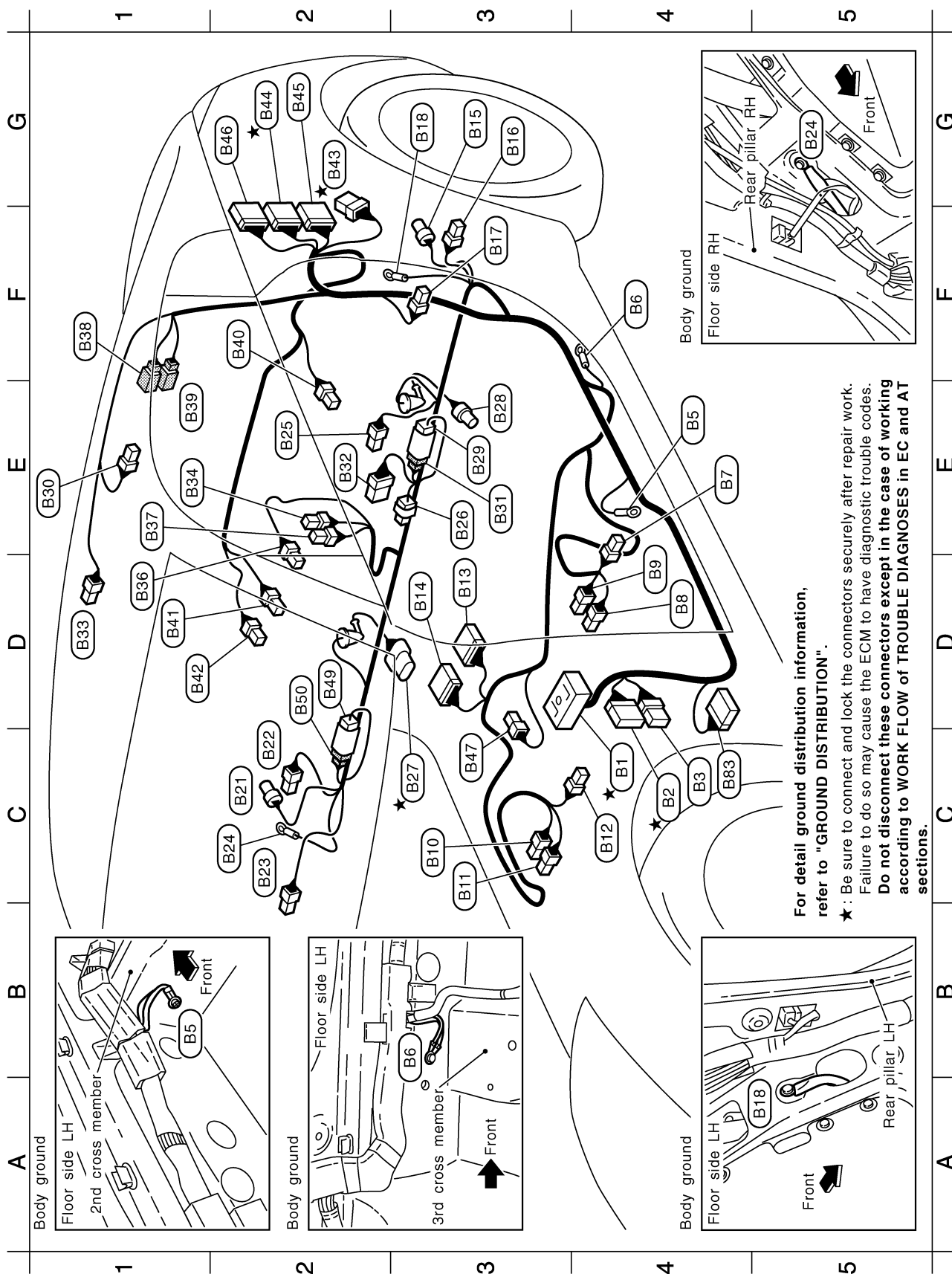

For detail ground distribution information, refer to "GROUND DISTRIBUTION".

★ : Be sure to connect and lock the connectors securely after repair work. Failure to do so may cause the ECM to have diagnostic trouble codes. Do not disconnect these connectors except in the case of working according to WORK FLOW of TROUBLE DIAGNOSES in EC and AT sections.

HARNESSES

E1	(B37)	L/4	: Heated seat relay (With heated seat or side air bag)
F1	(B38)	W/3	: To (D101)
E1	(B39)	GY/2	: To (D102)
F2	(B40)	BR/2	: Rear speaker LH
D1	(B41)	W/2	: Luggage floor box lamp
D1	(B42)	BR/2	: Rear speaker RH
G2	(B43)	W/6	: To (T1)
G2	(B44)	W/32	: To (T2)
G2	(B45)	W/10	: To (T3) (With BOSE system)
G2	(B46)	W/24	: To (T4) (With BOSE system)
C3	(B47)	B/1	: Parking brake switch
D2	(B49)	BR/2	: To (B50)
D2	(B50)	BR/2	: To (B49)
C4	(B83)	W/15	: BCM (Body control module)

★ : Be sure to connect and lock the connectors securely after repair work.
 Failure to do so may cause the ECM to have diagnostic trouble codes.
Do not disconnect these connectors except in the case of working according to WORK FLOW of TROUBLE DIAGNOSES in EC and AT sections.

C4	(B1)	SMJ	: To (M12)
C4	(B2)	W/18	: To (E106)
C4	(B3)	W/6	: To (E107)
E4	(B5)	—	: Body ground
F4	(B6)	—	: Body ground
E4	(B7)	W/4	: Driver side seat (With heated seat or side air bag)
D4	(B8)	W/3	: Seat belt buckle switch (Driver side)
D4	(B9)	Y/2	: LH side air bag module (With side air bag)
C3	(B10)	Y/2	: RH side air bag module (With side air bag)
C3	(B11)	W/3	: Seat belt buckle switch (Passenger side)
C4	(B12)	W/4	: Passenger side seat (With heated seat or side air bag)
D3	(B13)	Y/12	: Air bag diagnosis sensor unit
D3	(B14)	Y/12	: Air bag diagnosis sensor unit
G3	(B15)	Y/2	: LH side air bag (satellite) sensor (With side air bag)
G3	(B16)	Y/2	: Seat belt pre-tensioner LH
F3	(B17)	W/3	: Driver side door switch
G3	(B18)	—	: Body ground (With side air bag)
C2	(B21)	Y/2	: RH side air bag (satellite) sensor (With side air bag)
C2	(B22)	Y/2	: Seat belt pre-tensioner RH
C2	(B23)	W/3	: Passenger side door switch
C2	(B24)	—	: Body ground (With side air bag)
E2	(B25)	W/2	: Woofer (With BOSE system)
E3	(B26)	W/2	: Condenser
C3	(B27)	GY/5	: Fuel level sensor unit and fuel pump
E3	(B28)	GY/2	: Fuel level sensor unit (Sub)
E3	(B29)	W/2	: To (B31)
E1	(B30)	Y/2	: LH side curtain air bag module (With side air bag)
E3	(B31)	W/2	: To (B29)
E2	(B32)	BR/8	: Woofer amp. (With BOSE system)
D1	(B33)	Y/2	: RH side curtain air bag module (With side air bag)
E1	(B34)	BR/6	: Rear window defogger relay
D1	(B36)	B/2	: Power socket

TKIT0555E

HARNESS

Roadster Models

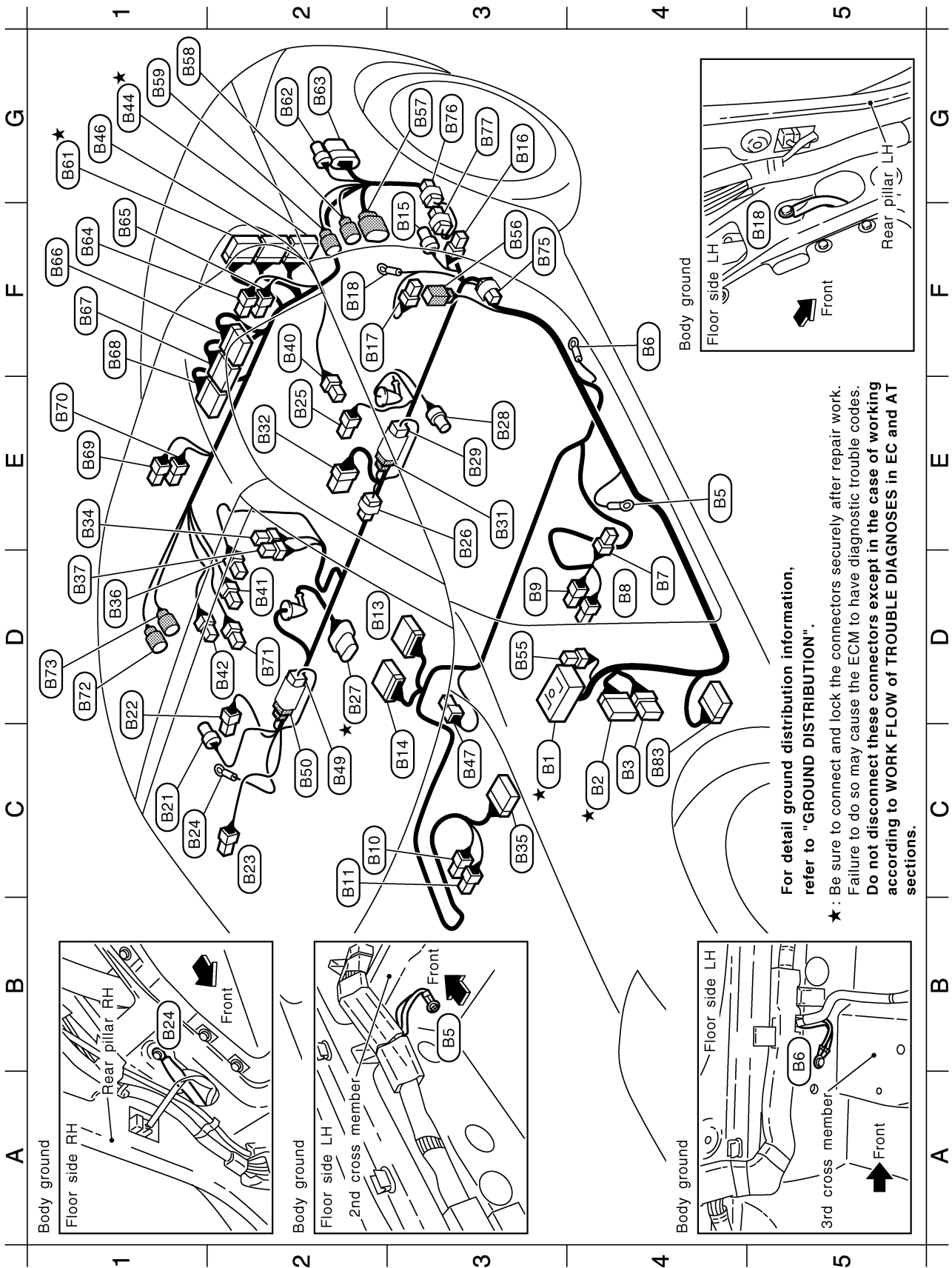

For detail ground distribution information, refer to "GROUND DISTRIBUTION".

★ : Be sure to connect and lock the connectors securely after repair work. Failure to do so may cause the ECM to have diagnostic trouble codes. Do not disconnect these connectors except in the case of working according to WORK FLOW of TROUBLE DIAGNOSES in EC and AT sections.

A B C D E F G
H I J K L M
N O P Q R S T U V W X Y Z
AA AB AC AD AE AF AG AH AI AJ AK AL AM AN AO AP AQ AR AS AT AU AV AW AX AY AZ
BA BB BC BD BE BF BG BH BI BJ BK BL BM BN BO BP BQ BR BS BT BU BV BW BX BY BZ
CA CB CC CD CE CF CG CH CI CJ CK CL CM CN CO CP CQ CR CS CT CU CV CW CX CY CZ
DA DB DC DD DE DF DG DH DI DJ DK DL DM DN DO DP DQ DR DS DT DU DV DW DX DY DZ
EA EB EC ED EE EF EG EH EI EJ EK EL EM EN EO EP EQ ER ES ET EU EV EW EX EY EZ
FA FB FC FD FE FF FG FH FI FJ FK FL FM FN FO FP FQ FR FS FT FU FV FW FX FY FZ
GA GB GC GD GE GF GG GH GI GJ GK GL GM GN GO GP GQ GR GS GT GU GV GW GX GY GZ
HA HB HC HD HE HF HG HH HI HJ HK HL HM HN HO HP HQ HR HS HT HU HV HW HX HY HZ
IA IB IC ID IE IF IG IH II IJ IK IL IM IN IO IP IQ IR IS IT IU IV IW IX IY IZ
JA JB JC JD JE JF JG JH JI JJ JK JL JM JN JO JP JQ JR JS JT JU JV JW JX JY JZ
KA KB KC KD KE KF KG KH KI KJ KL KM KN KO KP KQ KR KS KT KU KV KW KX KY KZ
LA LB LC LD LE LF LG LH LI LJ LK LL LM LN LO LP LQ LR LS LT LU LV LW LX LY LZ
MA MB MC MD ME MF MG MH MI MJ MK ML MN MO MP MQ MR MS MT MU MV MW MX MY MZ
NA NB NC ND NE NF NG NH NI NJ NK NL NM NO NP NQ NR NS NT NU NV NW NX NY NZ
OA OB OC OD OE OF OG OH OI OJ OK OL OM ON OO OP OQ OR OS OT OU OV OW OX OY OZ
PA PB PC PD PE PF PG PH PI PJ PK PL PM PN PO PP PQ PR PS PT PU PV PW PX PY PZ
QA QB QC QD QE QF QG QH QI QJ QK QL QM QN QO QQ QR QS QT QU QV QW QX QY QZ
RA RB RC RD RE RF RG RH RI RJ RK RL RM RN RO RP RQ RR RS RT RU RV RW RX RY RZ
SA SB SC SD SE SF SG SH SI SJ SK SL SM SN SO SP SQ SR SS ST SU SV SW SX SY SZ
TA TB TC TD TE TF TG TH TI TJ TK TL TM TN TO TP TQ TR TS TT TU TV TW TX TY TZ
UA UB UC UD UE UF UG UH UI UJ UK UL UM UN UO UP UQ UR US UT UU UV UW UX UY UZ
VA VB VC VD VE VF VG VH VI VJ VK VL VM VN VO VP VQ VR VS VT VU VW VX VY VZ
WA WB WC WD WE WF WG WH WI WJ WK WL WM WN WO WP WQ WR WS WT WU WV WW WX WY WZ
XA XB XC XD XE XF XG XH XI XJ XK XL XM XN XO XP XQ XR XS XT XU XV XW XX XY XZ
YA YB YC YD YE YF YG YH YI YJ YK YL YM YN YO YP YQ YR YS YT YU YV YW YX YY YZ
ZA ZB ZC ZD ZE ZF ZG ZH ZI ZJ ZK ZL ZM ZN ZO ZP ZQ ZR ZS ZT ZU ZV ZW ZX ZY ZZ

PG

HARNESSES

C3	★	(B1)	SMJ	:	To	(M12)	D3	(B55)	W/2	:	Circuit breaker
C4	★	(B2)	W/18	:	To	(E106)	F3	(B56)	W/2	:	Short connector
C4		(B3)	W/6	:	To	(E107)	G3	(B57)	GY/8	:	Soft top assembly
E4		(B5)	—	:	Body ground		G1	(B58)	B/2	:	Soft top assembly
F4		(B6)	—	:	Body ground		G1	(B59)	GY/2	:	Roof actuator LH
D4		(B7)	W/4	:	Driver side seat		G1	(B61)	W/16	:	To (T23)
D4		(B8)	W/3	:	Seat belt buckle switch (Driver side)		G2	(B62)	GY/4	:	To (T24) (With BOSE system)
D3		(B9)	Y/2	:	LH side air bag module (With side air bag)		G2	(B63)	B/6	:	To (T25) (With BOSE system)
C2		(B10)	Y/2	:	RH side air bag module (With side air bag)		F1	(B64)	W/2	:	Storage lid switch LH (Close)
C2		(B11)	W/3	:	Seat belt buckle switch (Passenger side)		F1	(B65)	B/2	:	Storage lid unlock actuator LH
D2		(B13)	Y/12	:	Air bag diagnosis sensor unit		F1	(B66)	W/16	:	Soft top control unit
C3		(B14)	Y/12	:	Air bag diagnosis sensor unit		F1	(B67)	W/20	:	Soft top control unit
F3		(B15)	Y/2	:	LH side air bag (satellite) sensor (With side air bag)		F1	(B68)	W/12	:	Soft top control unit
G3		(B16)	Y/2	:	Seat belt pre-tensioner LH		E1	(B69)	W/2	:	Storage lid switch RH (Close)
F2		(B17)	W/3	:	Driver side door switch		E1	(B70)	B/2	:	Storage lid unlock actuator RH
F2		(B18)	—	:	Body ground (With side air bag)		D2	(B71)	W/2	:	Trunk opener cancel switch
C1		(B21)	Y/2	:	RH side air bag (satellite) sensor (With side air bag)		D1	(B72)	GY/2	:	Roof actuator RH
D1		(B22)	Y/2	:	Seat belt pre-tensioner RH		D1	(B73)	B/2	:	Rear window defogger (Via sub-harness)
C2		(B23)	W/3	:	Passenger side door switch		F3	(B75)	W/2	:	Diode
C1		(B24)	—	:	Body ground (With side air bag)		G3	(B76)	W/2	:	Diode
E2		(B25)	W/2	:	Woofer (With BOSE system)		G3	(B77)	W/2	:	Diode
E3		(B26)	W/2	:	Condenser		C4	(B83)	W/15	:	BCM (Body control module)
D2	★	(B27)	GY/5	:	Fuel level sensor unit and fuel pump						
E3		(B28)	GY/2	:	Fuel level sensor unit (Sub)						
E3		(B29)	W/2	:	To (B31)						
E3		(B31)	W/2	:	To (B29)						
E2		(B32)	BR/8	:	Woofer amp. (With BOSE system)						
E1		(B34)	BR/6	:	Rear window defogger relay						
C3		(B35)	W/18	:	Passenger side seat						
D1		(B36)	B/2	:	Power socket						
D1		(B37)	L/4	:	Heated seat relay (With heated seat or side air bag)						
F2		(B40)	BR/2	:	Rear speaker LH						
D2		(B41)	W/2	:	Luggage floor box lamp						
D2		(B42)	BR/2	:	Rear speaker RH						
G1	★	(B44)	W/32	:	To (T2)						
G1		(B46)	W/24	:	To (T4) (With BOSE system)						
C3		(B47)	B/1	:	Parking brake switch						
C2		(B49)	BR/2	:	To (B50)						
C2		(B50)	BR/2	:	To (B49)						

★ : Be sure to connect and lock the connectors securely after repair work.
 Failure to do so may cause the ECM to have diagnostic trouble codes.
Do not disconnect these connectors except in the case of working according to WORK FLOW of TROUBLE DIAGNOSES in EC and AT sections.

TKIT0557E

HARNESS

A
B
C
D
E
F
G
H
I
J
PG
L
M

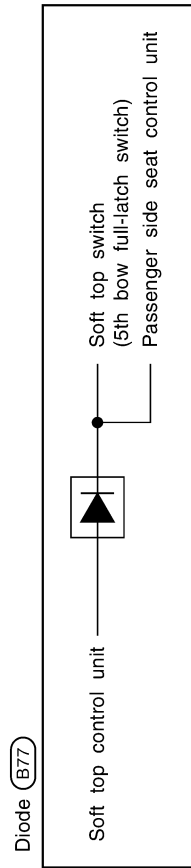
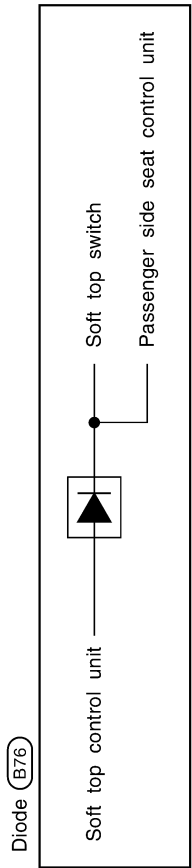
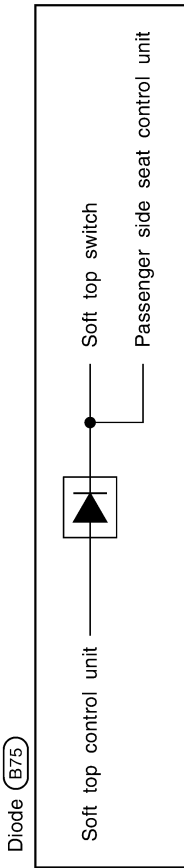

TKIT0117E

HARNESS

BODY HARNESS/TYPE 2

Coupe Models

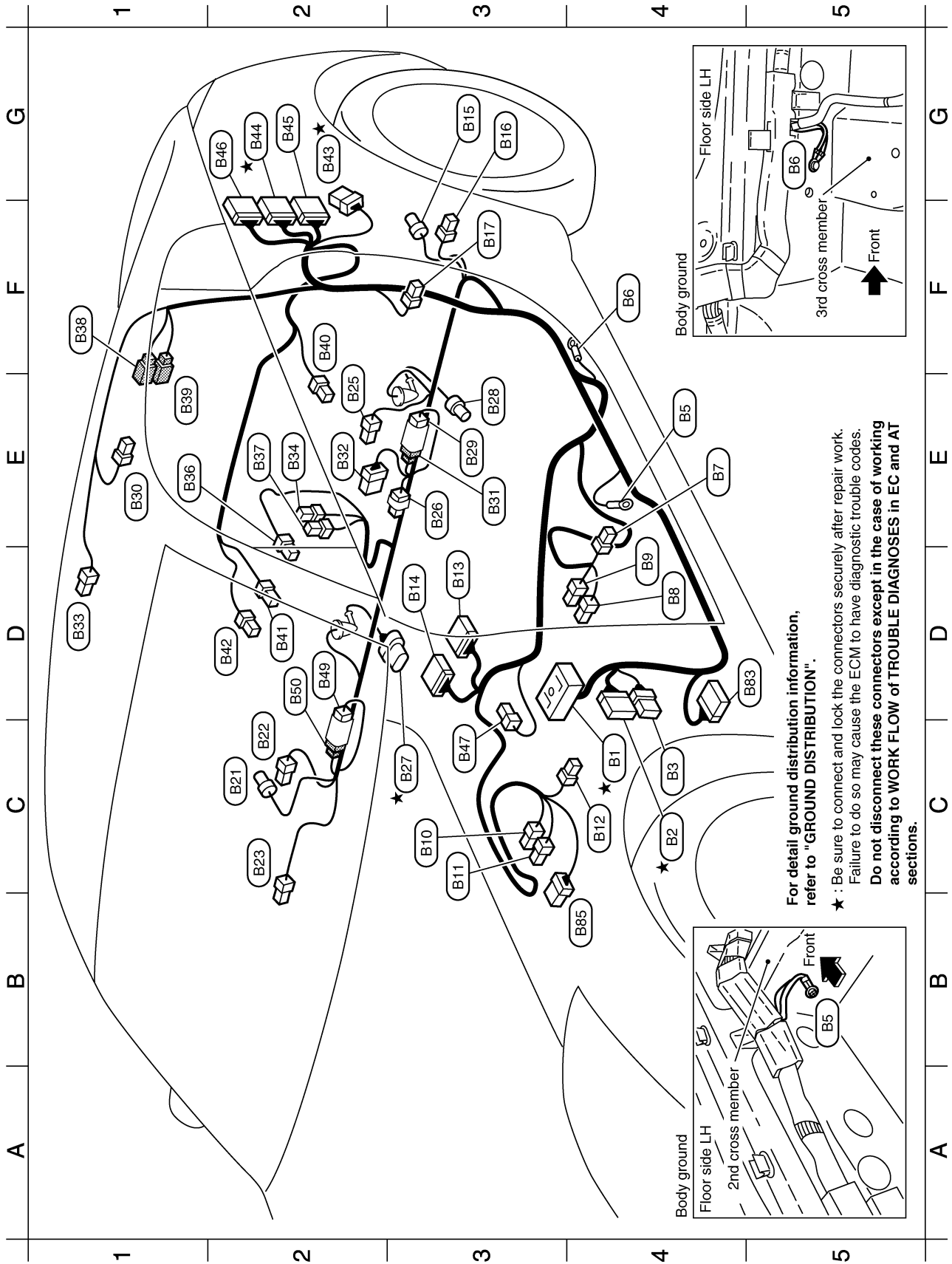

For detail ground distribution information, refer to "GROUND DISTRIBUTION".

- ★ : Be sure to connect and lock the connectors securely after repair work. Failure to do so may cause the ECM to have diagnostic trouble codes. Do not disconnect these connectors except in the case of working according to WORK FLOW of TROUBLE DIAGNOSES in EC and AT sections.

★ C4	(B1)	SMJ	:	To (M12)	(B37)	L/4	:	Heated seat relay (With heated seat or side air bag)
C4	★ (B2)	W/18	:	To (E106)	(B38)	W/3	:	To (D101)
C4	(B3)	W/6	:	To (E107)	(B39)	GY/2	:	To (D102)
E4	(B5)	—	:	Body ground	(B40)	BR/2	:	Rear speaker LH
F4	(B6)	—	:	Body ground	(B41)	W/2	:	Luggage floor box lamp
E4	(B7)	W/4	:	Driver side seat (With heated seat or side air bag)	(B42)	BR/2	:	Rear speaker RH
D4	(B8)	W/3	:	Seat belt buckle switch (Driver side)	★ (B43)	W/6	:	To (T1)
D4	(B9)	Y/2	:	LH side air bag module (With side air bag)	★ (B44)	W/32	:	To (T2)
C3	(B10)	Y/2	:	RH side air bag module (With side air bag)	(B45)	W/10	:	To (T3) (With BOSE system)
C3	(B11)	W/3	:	Seat belt buckle switch (Passenger side)	(B46)	W/24	:	To (T4) (With BOSE system)
C4	(B12)	W/4	:	Passenger side seat (With heated seat or side air bag)	(B47)	B/1	:	Parking brake switch
D3	(B13)	Y/12	:	Air bag diagnosis sensor unit	(B49)	BR/2	:	To (B50)
D3	(B14)	Y/12	:	Air bag diagnosis sensor unit	(B50)	BR/2	:	To (B49)
G3	(B15)	Y/2	:	LH side air bag (satellite) sensor (With side air bag)	(B83)	W/15	:	BCM (Body control module)
G3	(B16)	Y/2	:	Seat belt pre-tensioner LH	(B85)	W/8	:	Passenger side seat
F3	(B17)	W/3	:	Driver side door switch				
C2	(B21)	Y/2	:	RH side air bag (satellite) sensor (With side air bag)				
C2	(B22)	Y/2	:	Seat belt pre-tensioner RH				
C2	(B23)	W/3	:	Passenger side door switch				
E2	(B25)	W/2	:	Woofer (With BOSE system)				
E3	(B26)	W/2	:	Condenser				
C3	★ (B27)	GY/5	:	Fuel level sensor unit and fuel pump				
E3	(B28)	GY/2	:	Fuel level sensor unit (Sub)				
E3	(B29)	W/2	:	To (B31)				
E1	(B30)	Y/2	:	LH side curtain air bag module (With side air bag)				
E3	(B31)	W/2	:	To (B29)				
E2	(B32)	BR/8	:	Woofer amp. (With BOSE system)				
D1	(B33)	Y/2	:	RH side curtain air bag module (With side air bag)				
E2	(B34)	BR/6	:	Rear window defogger relay				
E1	(B36)	B/2	:	Power socket				

★ : Be sure to connect and lock the connectors securely after repair work.
 Failure to do so may cause the ECM to have diagnostic trouble codes.
Do not disconnect these connectors except in the case of working according to WORK FLOW of TROUBLE DIAGNOSES in EC and AT sections.

HARNESS

Roadster Models

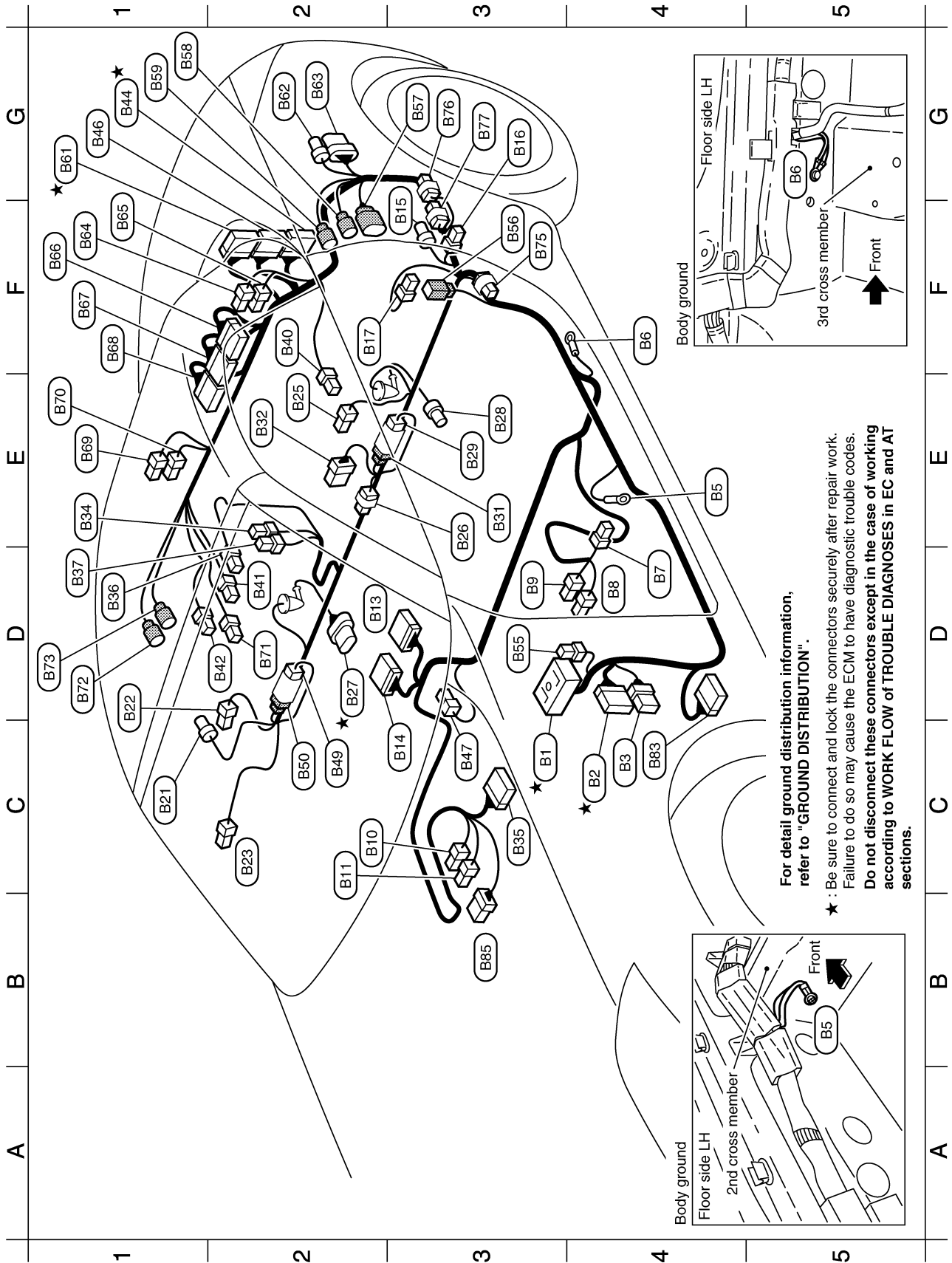

For detail ground distribution information, refer to "GROUND DISTRIBUTION".

- ★ : Be sure to connect and lock the connectors securely after repair work. Failure to do so may cause the ECM to have diagnostic trouble codes. Do not disconnect these connectors except in the case of working according to WORK FLOW of TROUBLE DIAGNOSES in EC and AT sections.

TKIT0849E

HARNESSES

★ C3	B1	SMJ	:	To (M12)	D3	B55	W/2	:	Circuit breaker
C4	★ B2	W/18	:	To (E106)	F3	B56	W/2	:	Short connector
C4	B3	W/6	:	To (E107)	G3	B57	GY/8	:	Soft top assembly
E4	B5	—	:	Body ground	G1	B58	B/2	:	Soft top assembly
F4	B6	—	:	Body ground	G1	B59	GY/2	:	Roof actuator LH
D4	B7	W/4	:	Driver side seat	G1	★ B61	W/16	:	To (T23)
D4	B8	W/3	:	Seat belt buckle switch (Driver side)	G2	B62	GY/4	:	To (T24) (With BOSE system)
D3	B9	Y/2	:	LH side air bag module (With side air bag)	G2	B63	B/6	:	To (T25) (With BOSE system)
C2	B10	Y/2	:	RH side air bag module (With side air bag)	F1	B64	W/2	:	Storage lid switch LH (Close)
C2	B11	W/3	:	Seat belt buckle switch (Passenger side)	F1	B65	B/2	:	Storage lid unlock actuator LH
D2	B13	Y/12	:	Air bag diagnosis sensor unit	F1	B66	W/16	:	Soft top control unit
C3	B14	Y/12	:	Air bag diagnosis sensor unit	F1	B67	W/20	:	Soft top control unit
F3	B15	Y/2	:	LH side air bag (satellite) sensor (With side air bag)	F1	B68	W/12	:	Soft top control unit
G3	B16	Y/2	:	Seat belt pre-tensioner LH	E1	B69	W/2	:	Storage lid switch RH (Close)
F2	B17	W/3	:	Driver side door switch	E1	B70	B/2	:	Storage lid unlock actuator RH
C1	B21	Y/2	:	RH side air bag (satellite) sensor (With side air bag)	D2	B71	W/2	:	Trunk opener cancel switch
D1	B22	Y/2	:	Seat belt pre-tensioner RH	D1	B72	GY/2	:	Roof actuator RH
C2	B23	W/3	:	Passenger side door switch	D1	B73	B/2	:	Rear window defogger (Via sub-harness)
E2	B25	W/2	:	Woofer (With BOSE system)	F3	B75	W/2	:	Diode
E3	B26	W/2	:	Condenser	G3	B76	W/2	:	Diode
D2	★ B27	GY/5	:	Fuel level sensor unit and fuel pump	G3	B77	W/2	:	Diode
E3	B28	GY/2	:	Fuel level sensor unit (Sub)	C4	B83	W/15	:	BCM (Body control module)
E3	B29	W/2	:	To (B31)	B3	B85	W/8	:	Passenger side seat
E3	B31	W/2	:	To (B29)					
E2	B32	BR/8	:	Woofer amp. (With BOSE system)					
E1	B34	BR/6	:	Rear window defogger relay					
C3	B35	W/18	:	Passenger side seat					
D1	B36	B/2	:	Power socket					
D1	B37	L/4	:	Heated seat relay (With heated seat or side air bag)					
F2	B40	BR/2	:	Rear speaker LH					
D2	B41	W/2	:	Luggage floor box lamp					
D2	B42	BR/2	:	Rear speaker RH					
G1	★ B44	W/32	:	To (T2)					
G1	B46	W/24	:	To (T4) (With BOSE system)					
C3	B47	B/1	:	Parking brake switch					
C2	B49	BR/2	:	To (B50)					
C2	B50	BR/2	:	To (B49)					

★ : Be sure to connect and lock the connectors securely after repair work.
 Failure to do so may cause the ECM to have diagnostic trouble codes.
Do not disconnect these connectors except in the case of working according to WORK FLOW of TROUBLE DIAGNOSES in EC and AT sections.

A
B
C
D
E
F
G
H
I
J
PG
L
M

HARNESS

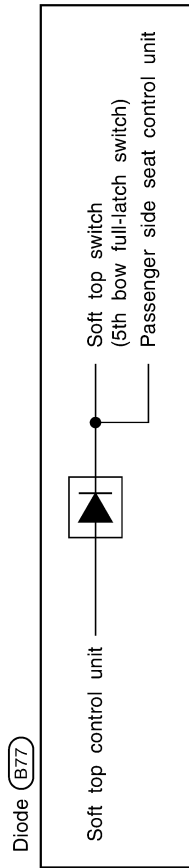
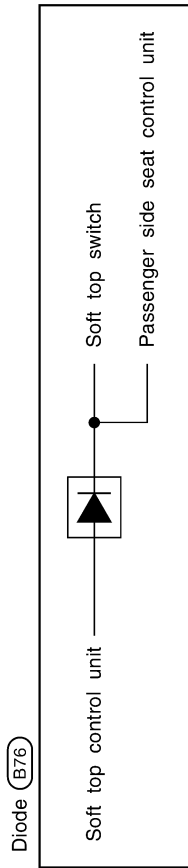
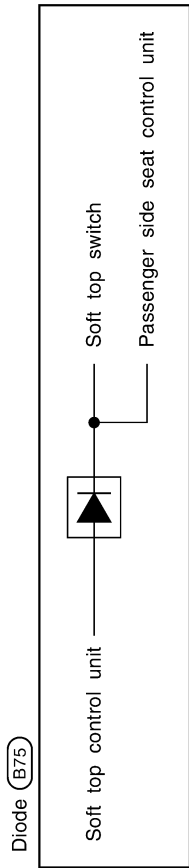

TKIT0117E

HARNESS

BODY NO. 2 HARNESS/TYPE 1

- (B101) SMJ : To (M73)
- (B102) — : Body ground
- (B104) W/40 : NAVI control unit
- (B105) W/32 : NAVI control unit

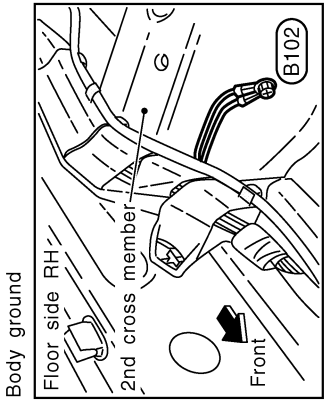
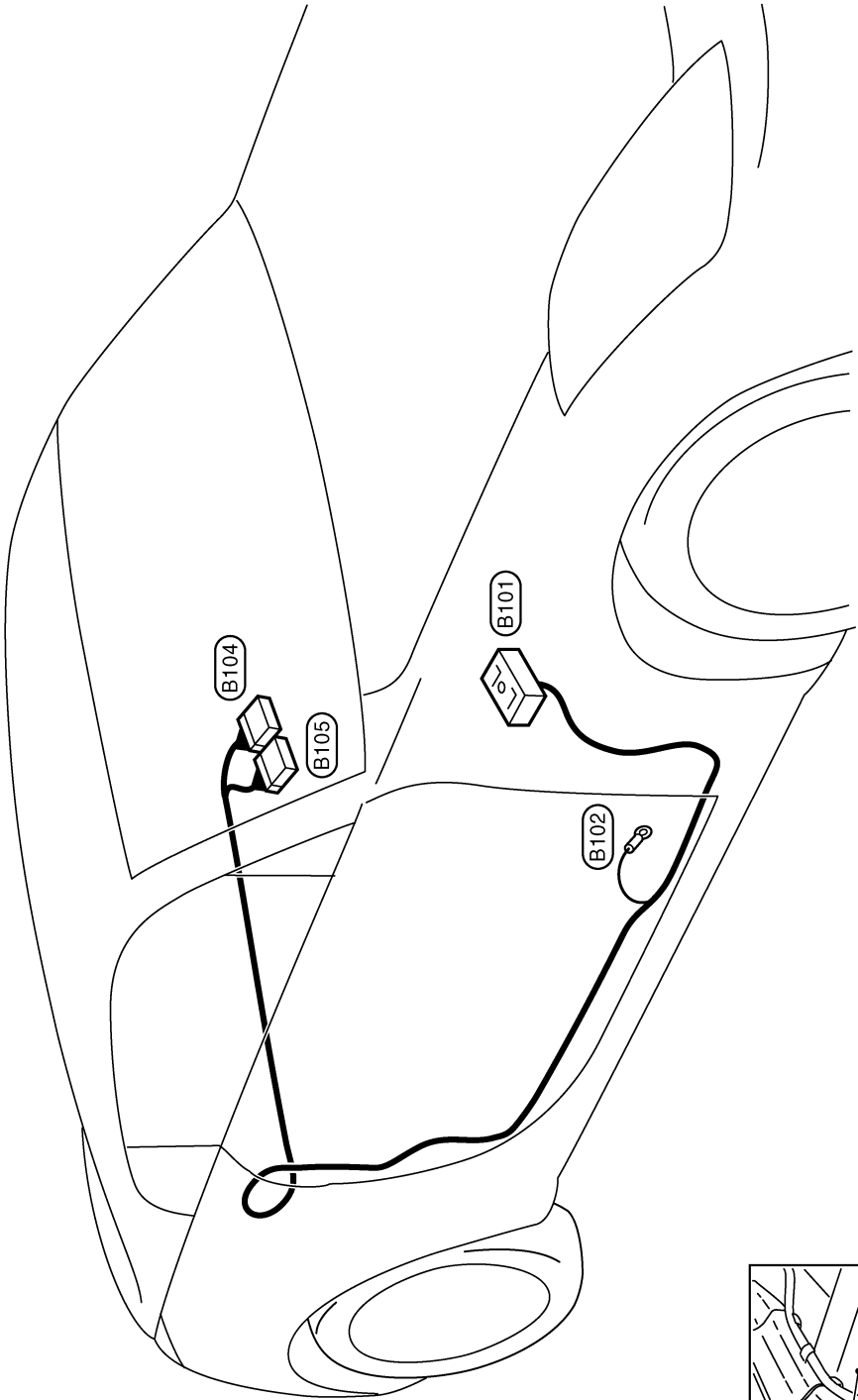

For detail ground distribution information, refer to "GROUND DISTRIBUTION".

A
B
C
D
E
F
G
H
I
J
PG
L
M

HARNESS

BODY NO. 2 HARNESS/TYPE 2

★ : Be sure to connect and lock the connectors securely after repair work.
 Failure to do so may cause the ECM to have diagnostic trouble codes.
Do not disconnect these connectors except in the case of working according to WORK FLOW of TROUBLE DIAGNOSES in EC and AT sections.

(B101)	SMJ	:	To (M73)
★(B102)	—	:	Body ground
(B104)	W/40	:	NAVI control unit (With navigation system)
(B105)	W/32	:	NAVI control unit (With navigation system)
(B112)	W/4	:	To (M68) (With VDC system)
★(B113)	W/4	:	To (F103)
(B114)	SMJ	:	VDC / TCS / ABS control unit (With VDC system)
(B115)	—	:	Body ground (With navigation system)

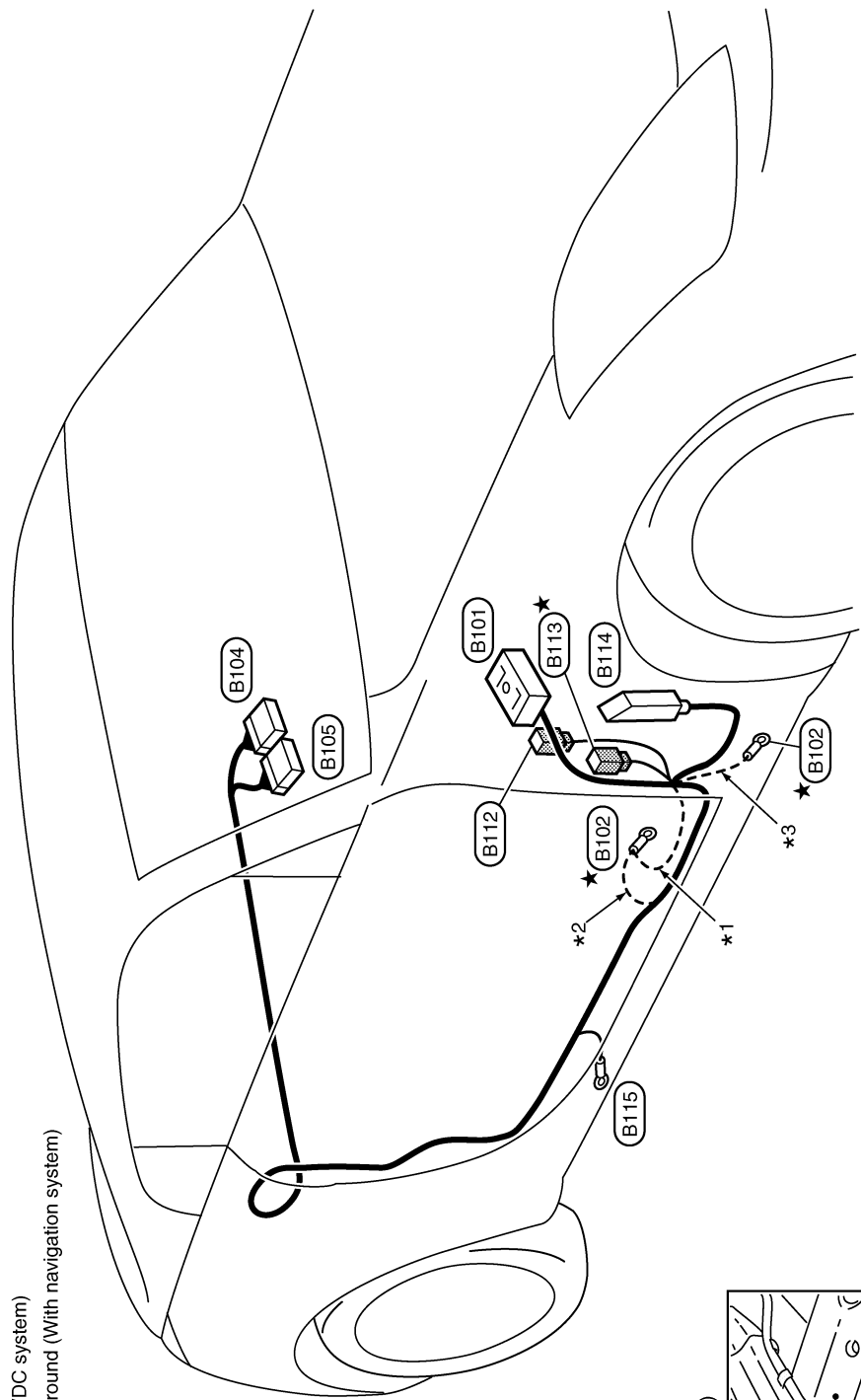

*1 : With VDC system and navigation system
 *2 : With VDC system without navigation system
 *3 : With navigation system without VDC system

For detail ground distribution information, refer to "GROUND DISTRIBUTION".

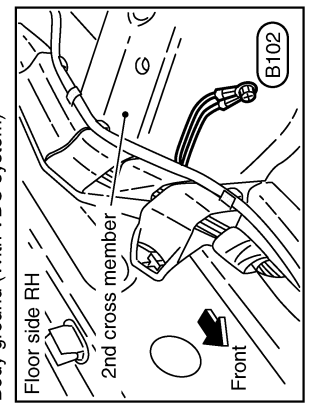

TKIT0851E

TAIL HARNESS/TYPE 1 Coupe Models

- ★ (T1) W/6 : To (B43)
- ★ (T2) W/32 : To (B44)
- (T3) W/10 : To (B45) (With BOSE system)
- (T4) W/24 : To (B46) (With BOSE system)
- (T5) GY/4 : Rear wheel sensor
- (T6) GY/8 : BOSE speaker amp. (With BOSE system)
- (T7) B/24 : BOSE speaker amp. (With BOSE system)
- (T8) GY/3 : Rear combination lamp LH (Body side)
- (T9) GY/4 : Rear combination lamp LH (Bumper side)
- (T10) W/4 : Back door opener actuator
- (T11) W/3 : Back door switch
- (T12) GY/2 : Luggage room lamp
- (T13) — : Body ground
- (T14) GY/4 : To (T101)
- (T15) GY/3 : Rear combination lamp RH (Body side)
- (T16) GY/4 : Rear combination lamp RH (Bumper side)

- (T19) W/4 : Fuel lid opener actuator
- ★ (T20) B/2 : EVAP canister vent control valve
- ★ (T21) GY/3 : EVAP control system pressure sensor
- (T42) W/16 : Satellite radio tuner (With BOSE system)

Tail sub-harness-1

- (T101) GY/4 : To (T15)
- (T102) BR/2 : License plate lamp LH
- (T103) GY/2 : Back door opener switch
- (T104) BR/2 : License plate lamp RH

★ : Be sure to connect and lock the connectors securely after repair work.
Failure to do so may cause the ECM to have diagnostic trouble codes.
Do not disconnect these connectors except in the case of working according to WORK FLOW of TROUBLE DIAGNOSES in EC and AT sections.

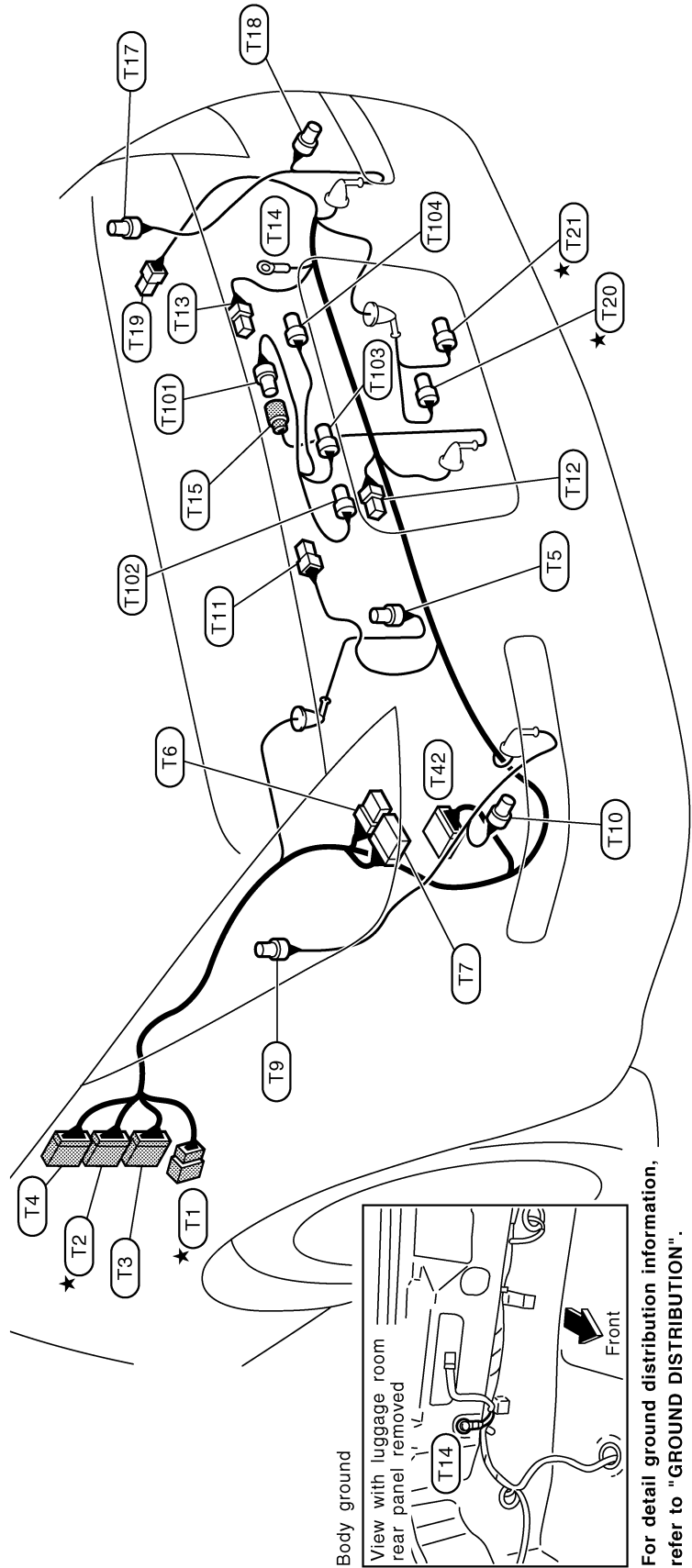

Body ground
View with luggage room rear panel removed
Front
For detail ground distribution information, refer to "GROUND DISTRIBUTION".

TKIT0559E

A
B
C
D
E
F
G
H
I
J
L
M

PG

HARNESS

Roadster Models

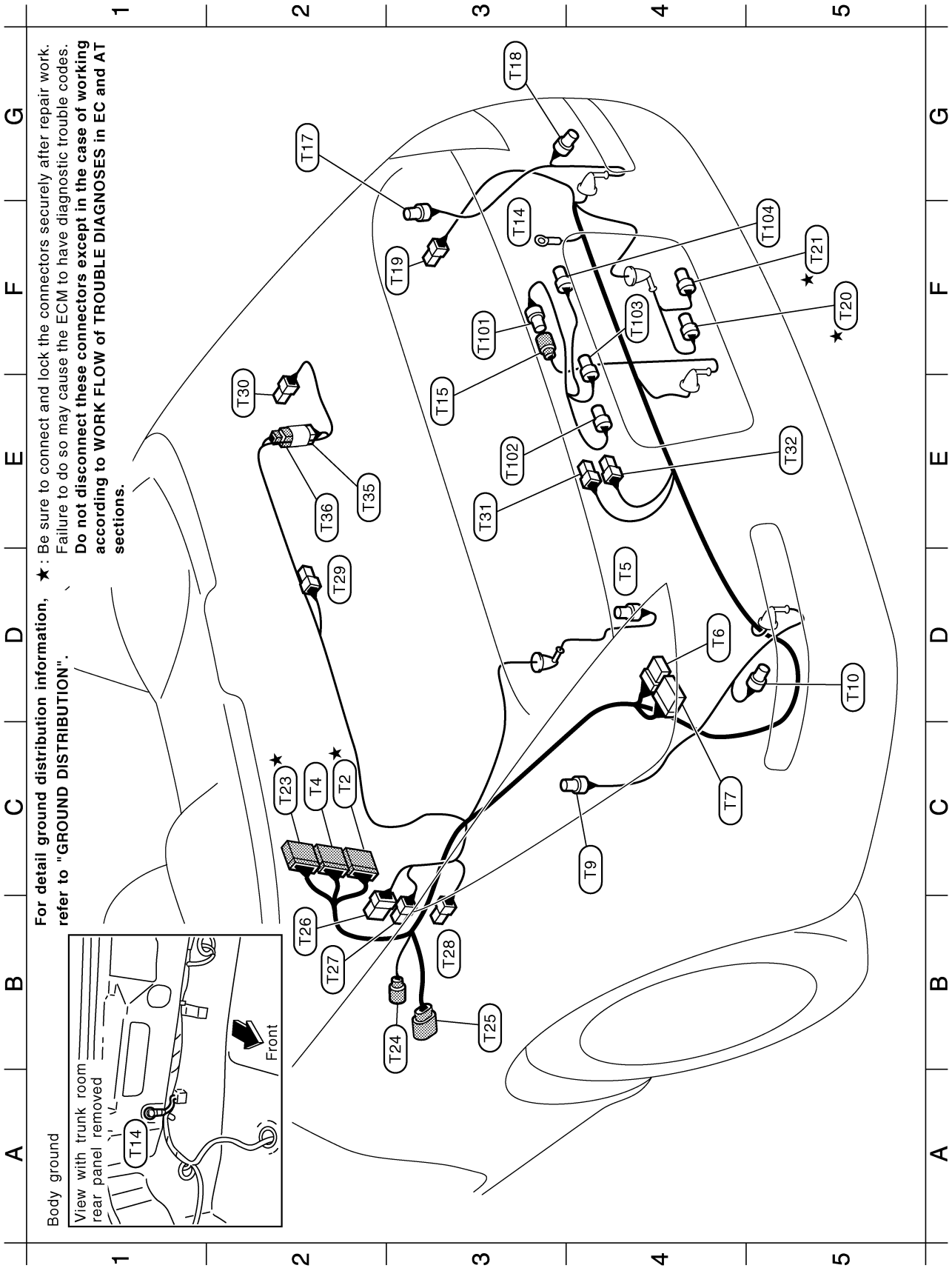

TKIT0560E

Tail sub-harness-1

F3 (T101) GY/4 : To (T15)
 E3 (T102) BR/2 : License plate lamp LH
 F4 (T103) GY/2 : Trunk lid opener switch
 F5 (T104) BR/2 : License plate lamp RH

★ : Be sure to connect and lock the connectors securely after repair work.
 Failure to do so may cause the ECM to have diagnostic trouble codes.
Do not disconnect these connectors except in the case of working according to WORK FLOW of TROUBLE DIAGNOSES in EC and AT sections.

C2 ★ (T2) W/32 : To (B44)
 C2 (T4) W/24 : To (B46) (With BOSE system)
 D4 (T5) GY/4 : Rear wheel sensor
 D4 (T6) GY/8 : BOSE speaker amp. (With BOSE system)
 C4 (T7) B/24 : BOSE speaker amp. (With BOSE system)
 C4 (T9) GY/3 : Rear combination lamp LH (Body side)
 D5 (T10) GY/4 : Rear combination lamp LH (Bumper side)
 F3 (T14) — : Body ground
 E3 (T15) GY/4 : To (T101)
 G2 (T17) GY/3 : Rear combination lamp RH (Body side)
 G3 (T18) GY/4 : Rear combination lamp RH (Bumper side)
 F3 (T19) W/4 : Fuel lid opener actuator
 F5 ★ (T20) B/2 : EVAP canister vent control valve
 F5 ★ (T21) GY/3 : EVAP control system pressure sensor
 C2 ★ (T23) W/16 : To (B61)
 B3 (T24) GY/4 : To (B62) (With BOSE system)
 B3 (T25) B/6 : To (B63) (With BOSE system)
 B2 (T26) W/8 : To (T151)
 B2 (T27) B/2 : Storage lid switch (Open)
 B3 (T28) W/2 : Storage lid actuator LH
 D2 (T29) W/2 : Trunk room lamp
 E2 (T30) W/2 : Storage lid actuator RH
 E3 (T31) W/2 : Trunk room lamp switch
 E5 (T32) B/2 : Trunk lid opener actuator
 E2 (T35) W/2 : To (T36)
 E2 (T36) W/2 : To (T35)

A
 B
 C
 D
 E
 F
 G
 H
 I
 J
 PG
 L
 M

TAIL HARNESS/TYPE 2

Coupe Models

- ★ (T1) W/6 : To (B43)
- ★ (T2) W/32 : To (B44)
- (T3) W/10 : To (B45) (With BOSE system)
- (T4) W/24 : To (B46) (With BOSE system)
- (T5) GY/4 : Rear wheel sensor
- (T6) GY/8 : BOSE speaker amp. (With BOSE system)
- (T7) B/24 : BOSE speaker amp. (With BOSE system)
- (T9) GY/3 : Rear combination lamp LH (Body side)
- (T10) GY/4 : Rear combination lamp LH (Bumper side)
- (T11) W/4 : Back door opener actuator
- (T12) W/3 : Back door switch
- (T13) GY/2 : Luggage room lamp
- (T14) — : Body ground
- (T15) GY/4 : To (T10)
- (T17) GY/3 : Rear combination lamp RH (Body side)
- (T18) GY/4 : Rear combination lamp RH (Bumper side)

- (T19) W/4 : Fuel lid opener actuator
- ★ (T20) B/2 : EVAP canister vent control valve
- ★ (T21) GY/3 : EVAP control system pressure sensor
- (T42) W/16 : Satellite radio tuner (With BOSE system)

Tail sub-harness-1

- (T101) GY/4 : To (T15)
- (T102) BR/2 : License plate lamp LH
- (T103) GY/2 : Back door opener switch
- (T104) BR/2 : License plate lamp RH

★ : Be sure to connect and lock the connectors securely after repair work. Failure to do so may cause the ECM to have diagnostic trouble codes. **Do not disconnect these connectors except in the case of working according to WORK FLOW of TROUBLE DIAGNOSES in EC and AT sections.**

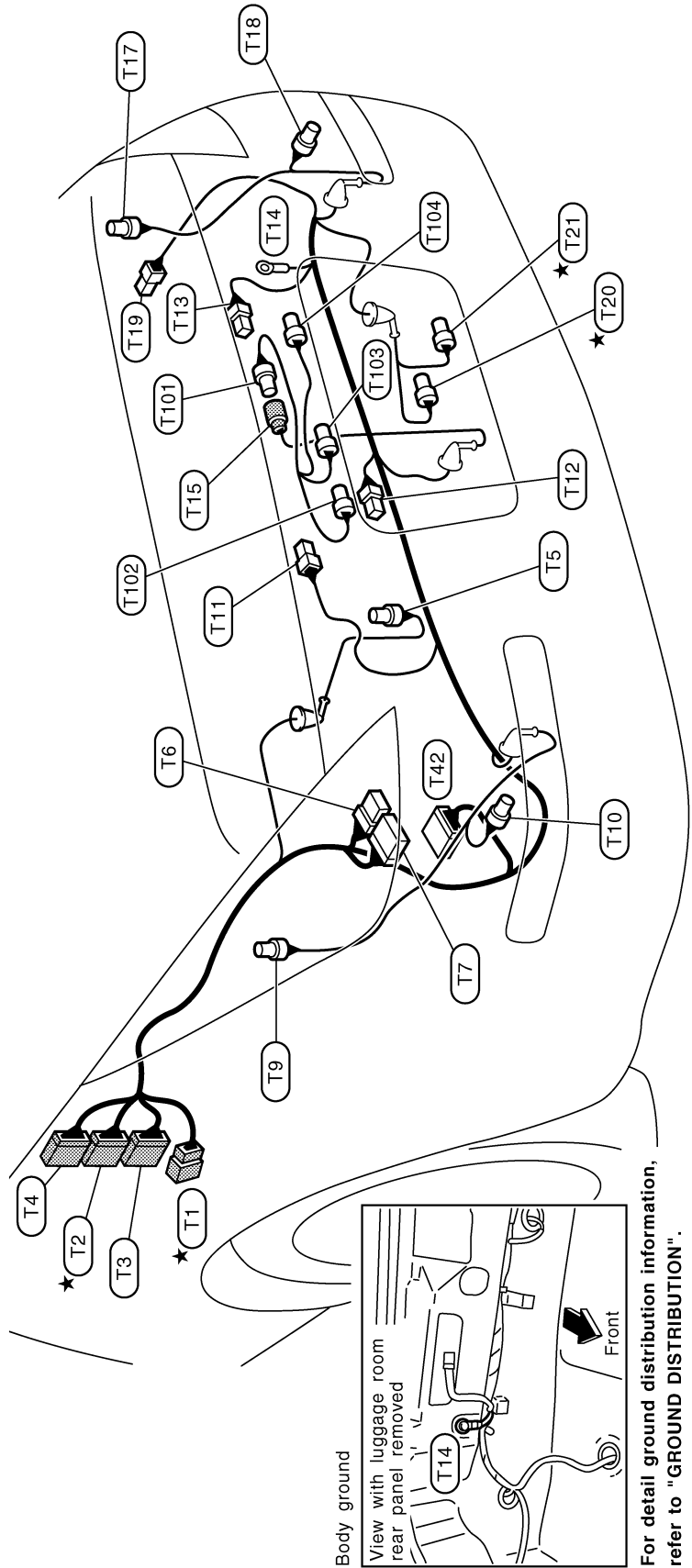

TKIT0559E

HARNESS

Roadster Models

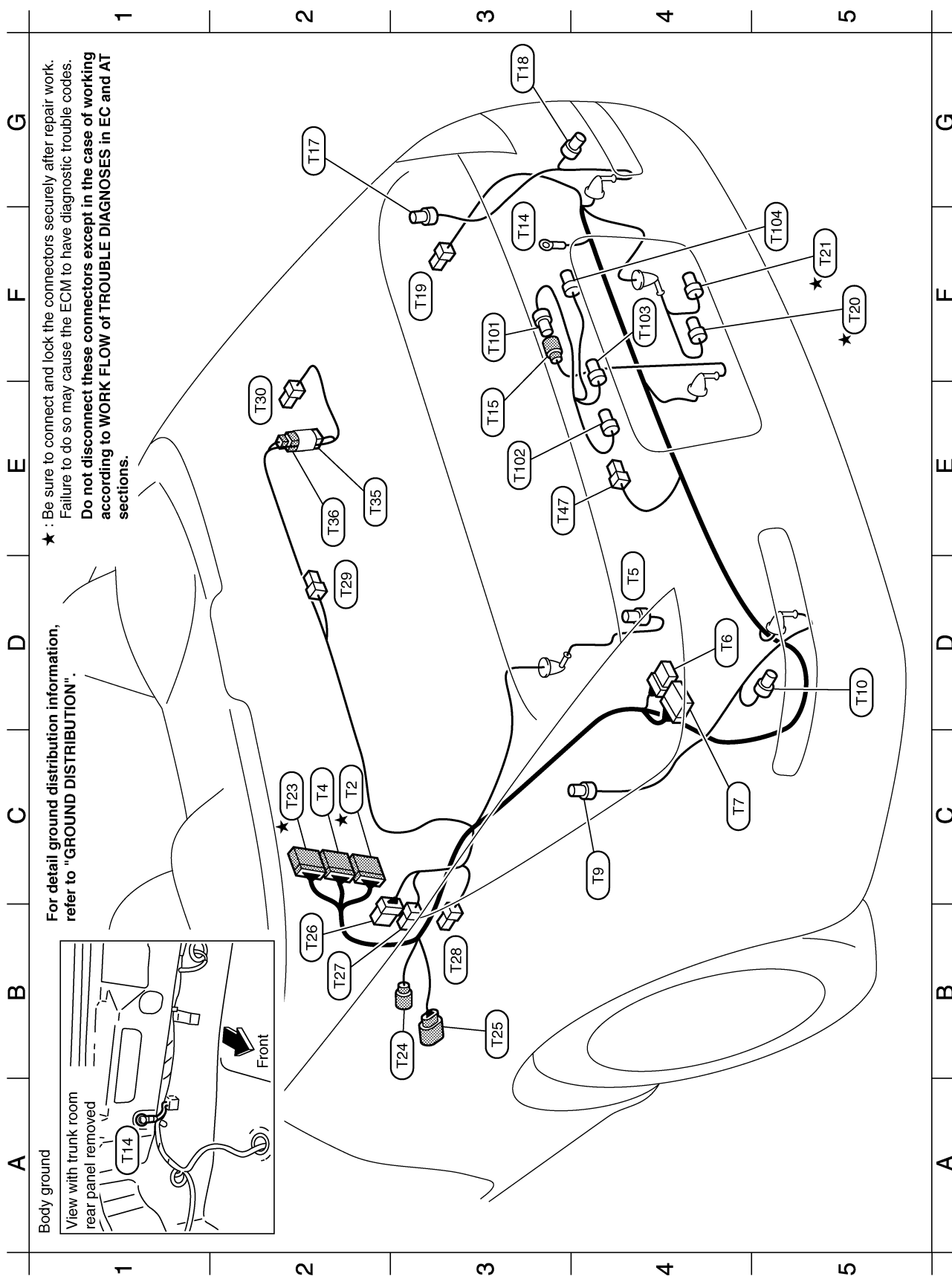

★ : Be sure to connect and lock the connectors securely after repair work. Failure to do so may cause the ECM to have diagnostic trouble codes. Do not disconnect these connectors except in the case of working according to WORK FLOW of TROUBLE DIAGNOSES in EC and AT sections.

For detail ground distribution information, refer to "GROUND DISTRIBUTION".

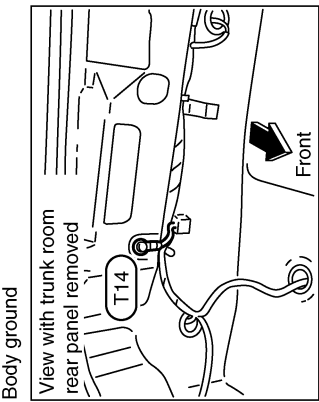

Tail sub-harness-1

★ C2	T2	W/32	:	To	(B44)
C2	T4	W/24	:	To	(B46) (With BOSE system)
D4	T5	GY/4	:	Rear wheel sensor	
D4	T6	GY/8	:	BOSE speaker amp. (With BOSE system)	
C4	T7	B/24	:	BOSE speaker amp. (With BOSE system)	
C4	T9	GY/3	:	Rear combination lamp LH (Body side)	
D5	T10	GY/4	:	Rear combination lamp LH (Bumper side)	
F3	T14	—	:	Body ground	
E3	T15	GY/4	:	To	(T101)
G2	T17	GY/3	:	Rear combination lamp RH (Body side)	
G3	T18	GY/4	:	Rear combination lamp RH (Bumper side)	
F3	T19	W/4	:	Fuel lid opener actuator	
F5	★ T20	B/2	:	EVAP canister vent control valve	
F5	★ T21	GY/3	:	EVAP control system pressure sensor	
C2	★ T23	W/16	:	To	(B61)
B3	T24	GY/4	:	To	(B62) (With BOSE system)
B3	T25	B/6	:	To	(B63) (With BOSE system)
B2	T26	W/8	:	To	(T151)
B2	T27	B/2	:	Storage lid switch (Open)	
B3	T28	W/2	:	Storage lid actuator LH	
D2	T29	W/2	:	Trunk room lamp	
E2	T30	W/2	:	Storage lid actuator RH	
E2	T35	W/2	:	To	(T36)
E2	T36	W/2	:	To	(T35)
E3	T47	W/3	:	Trunk lid lock assembly	

F3	(T101)	GY/4	:	To	(T15)
E3	(T102)	BR/2	:	License plate lamp LH	
F4	(T103)	GY/2	:	Trunk lid opener switch	
F5	(T104)	BR/2	:	License plate lamp RH	

★ : Be sure to connect and lock the connectors securely after repair work.
 Failure to do so may cause the ECM to have diagnostic trouble codes.
Do not disconnect these connectors except in the case of working according to WORK FLOW of TROUBLE DIAGNOSES in EC and AT sections.

HARNESS

TAIL NO. 2 HARNESS Roadster Models

A
B
C
D
E
F
G
H
I
J
PG
L
M

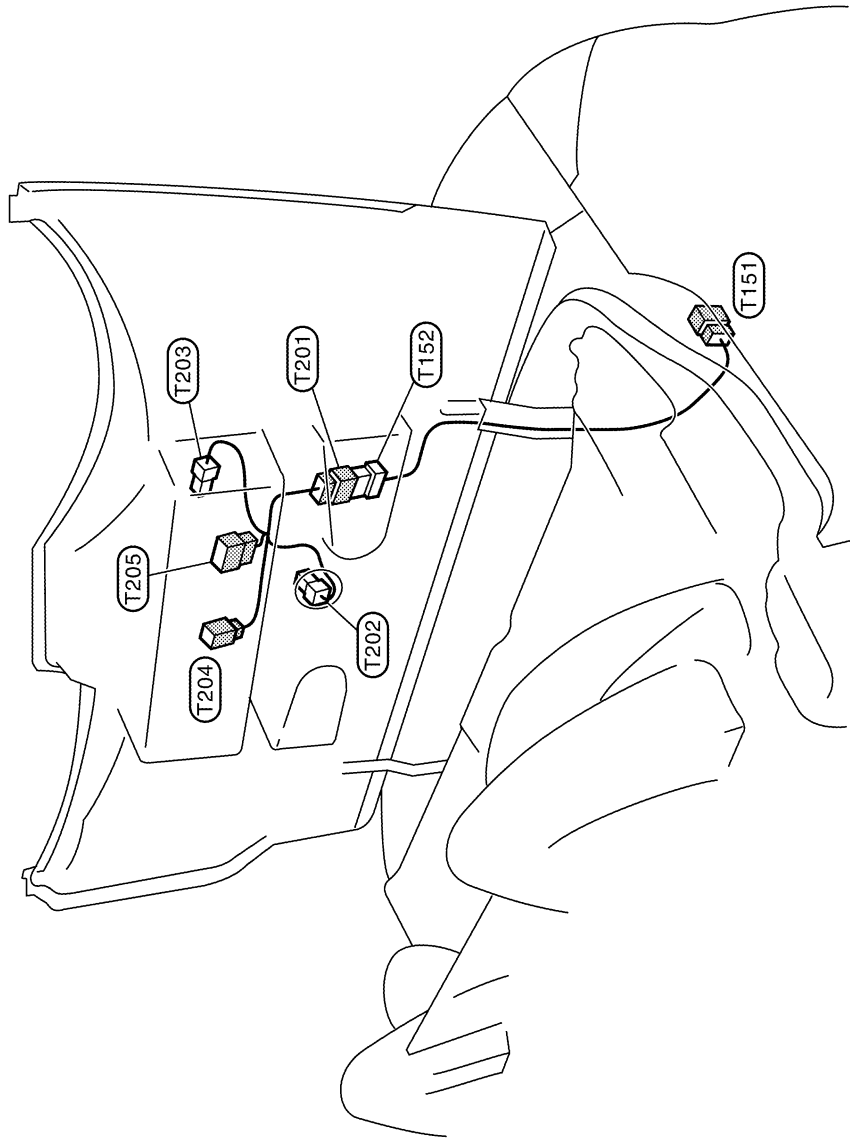

Tail No.2 harness

- (T201) W/8 : To (T152)
- (T202) BR/2 : High-mounted stop lamp
- (T203) W/4 : 5th bow unlock actuator
- (T204) B/2 : 5th bow closure motor
- (T205) W/6 : Soft top lock switch

Tail sub-harness-2

- (T151) W/8 : To (T26)
- (T152) W/8 : To (T201)

HARNESS

ROOM LAMP HARNESS/TYPE 1 Coupe Models

Room lamp sub-harness

(R51) W/4 : To (M70)
 (R52) W/3 : Map lamp

(R2) W/12 : To (M93)
 (R3) W/2 : Vanity mirror lamp LH
 (R4) B/10 : Auto anti-dazzling inside mirror
 (R5) W/2 : Vanity mirror lamp RH

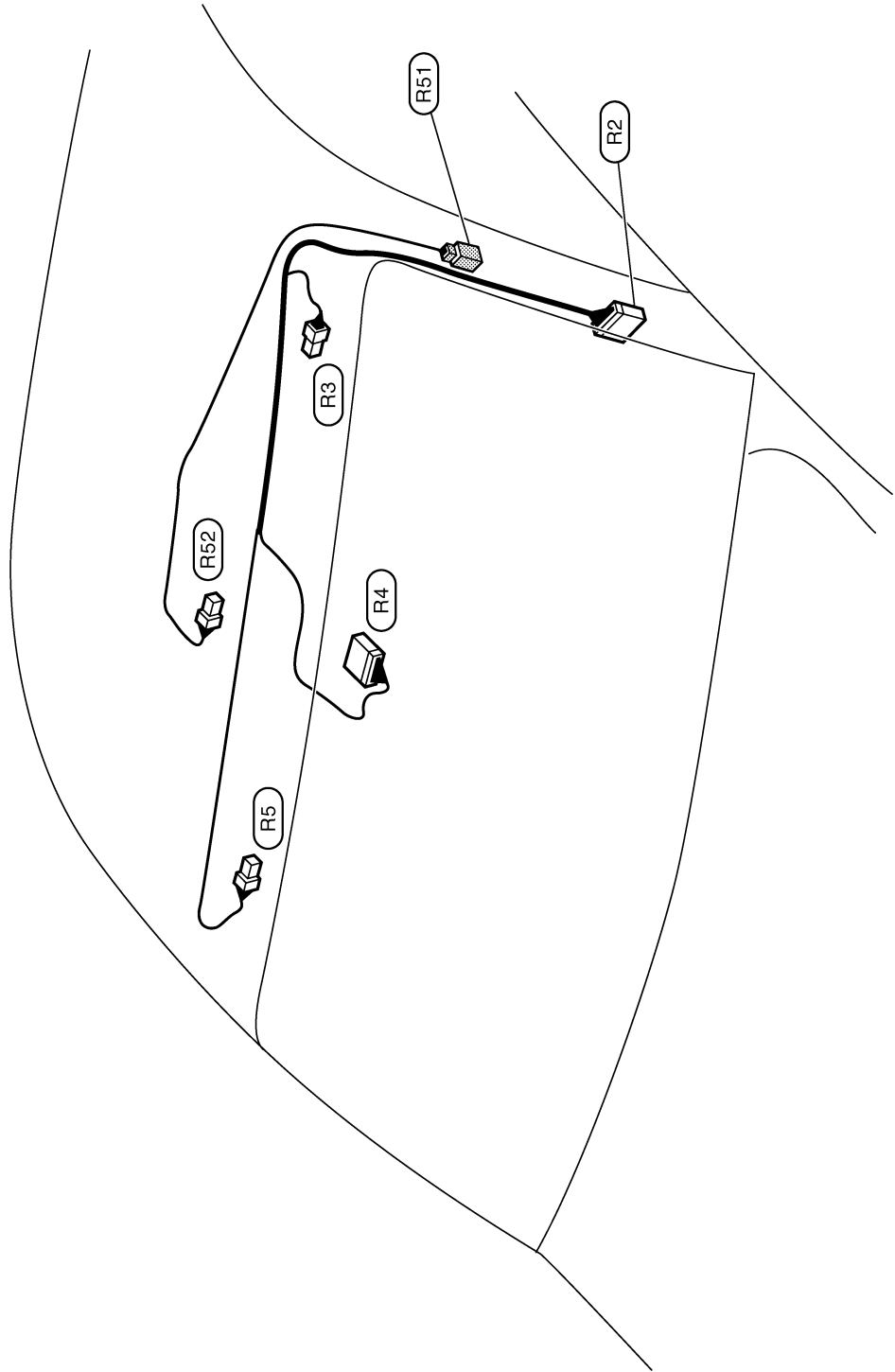

TKIT0301E

HARNESS

Roadster Models

Room lamp sub-harness

(R51) W/4 : To (M70)
 (R53) W/4 : Map lamp

(R2) W/12 : To (M93)
 (R3) W/2 : Vanity mirror lamp LH
 (R4) B/10 : Auto anti-dazzling inside mirror
 (R5) W/2 : Vanity mirror lamp RH
 (R8) W/4 : Soft top front lock switch

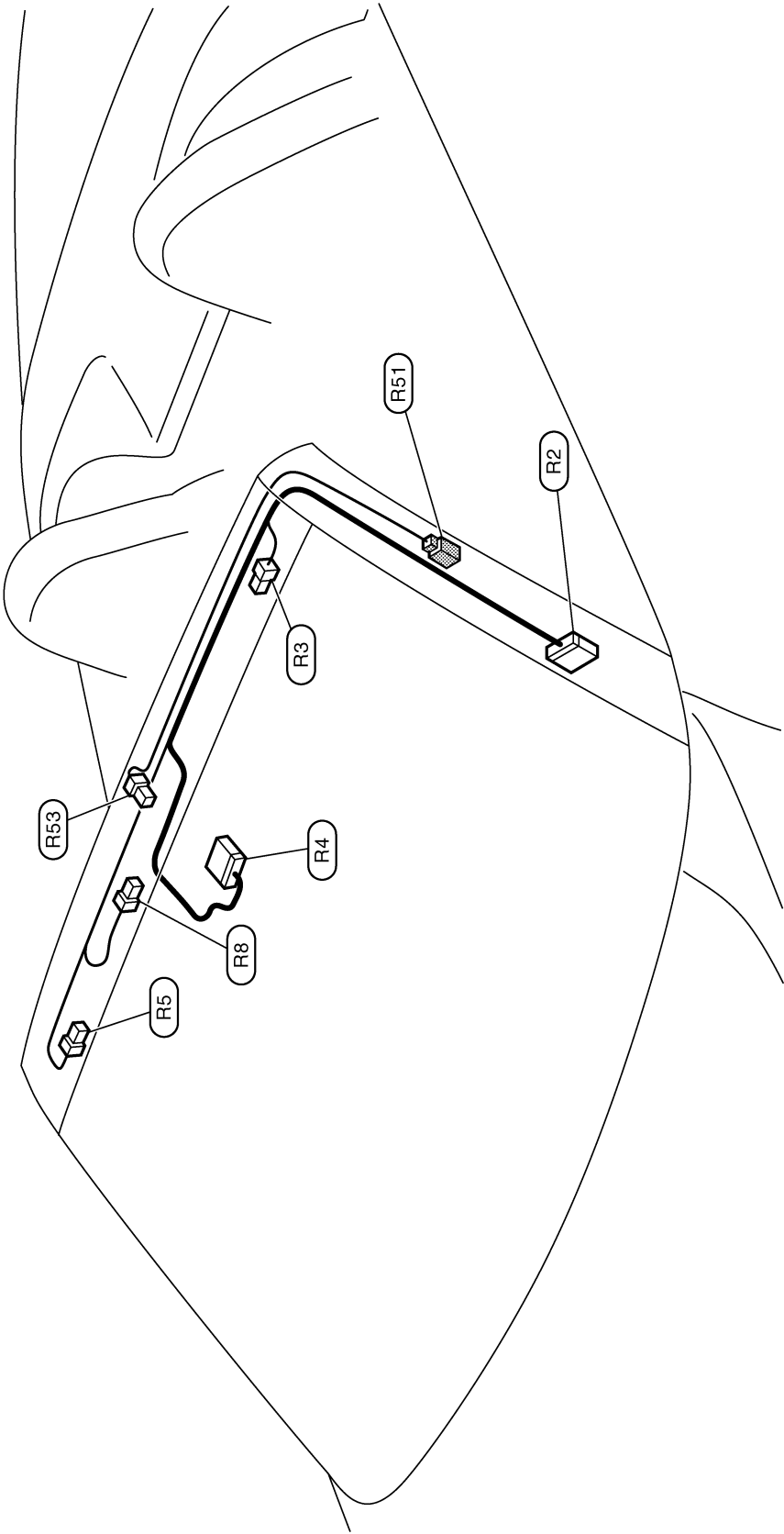

A
 B
 C
 D
 E
 F
 G
 H
 I
 J
 PG
 L
 M

TKIT0562E

HARNESS

ROOM LAMP HARNESS/TYPE 2 Coupe Models

- (R2) W/12 : To (M93)
- (R3) W/2 : Vanity mirror lamp LH
- (R4) B/10 : Auto anti-dazzling inside mirror
- (R5) W/2 : Vanity mirror lamp RH

Room lamp sub-harness

- (R52) W/3 : Map lamp
- (R57) W/12 : To (M43)
- (R58) W/12 : Front passenger air bag off indicator

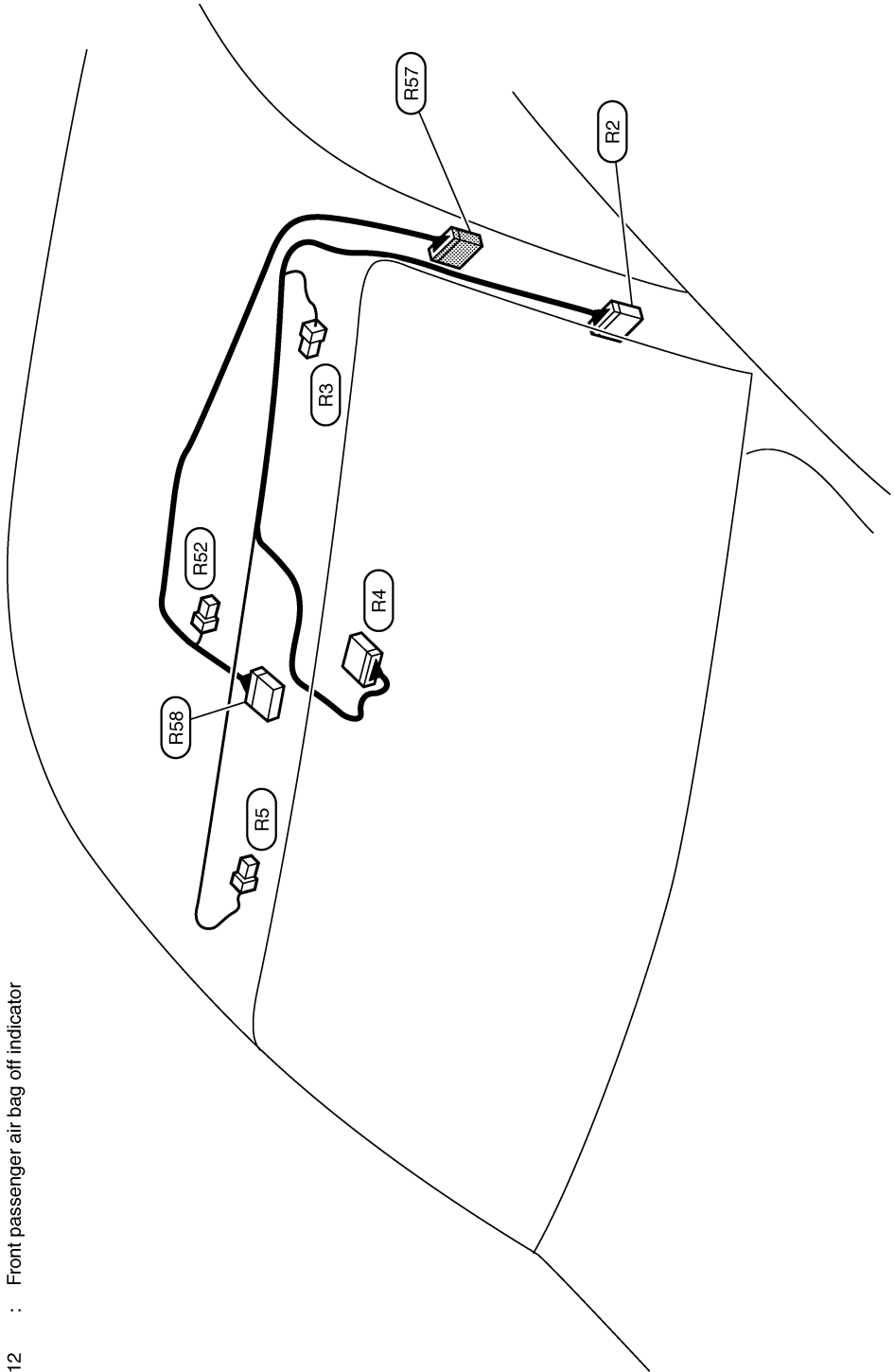

TKIT0854E

HARNESS

Roadster Models

A
B
C
D
E
F
G
H
I
J
PG
L
M

- (R2) : To (M93) W/12
- (R3) : Vanity mirror lamp LH W/2
- (R4) : Auto anti-dazzling inside mirror B/10
- (R5) : Vanity mirror lamp RH W/2
- (R8) : Soft top front lock switch W/4

Room lamp sub-harness

- (R59) : Map lamp W/4
- (R57) : To (M43) W/12
- (R58) : Front passenger air bag off indicator W/12

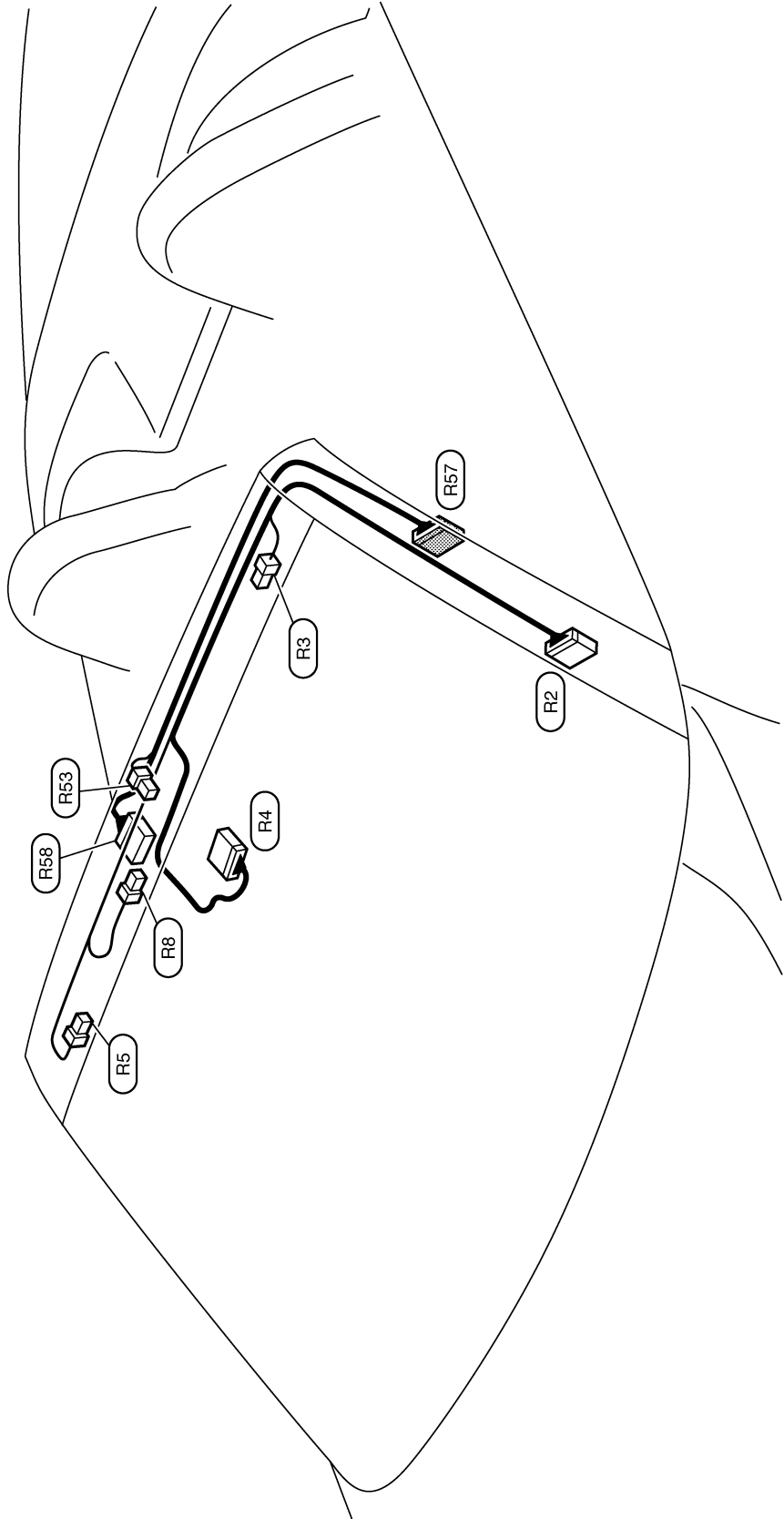

TKIT0855E

HARNESS

DOOR HARNESS

Driver Side Door

- (D1) SMJ : To (M11)
- (D2) W/8 : Door mirror (Driver side)
- (D3) BR/2 : Tweeter (Driver side)
- (D4) W/2 : Driver door speaker (Without BOSE system)
- (D5) BR/2 : Driver door speaker (With BOSE system)
- (D6) W/10 : Door mirror remote control switch
- (D7) W/16 : Power window main switch
- (D9) W/6 : Driver side power window motor
- (D11) GY/4 : Driver side door lock actuator
- (D12) BR/3 : Door key cylinder switch
- (D14) GY/2 : Bottle holder illumination (Driver side)

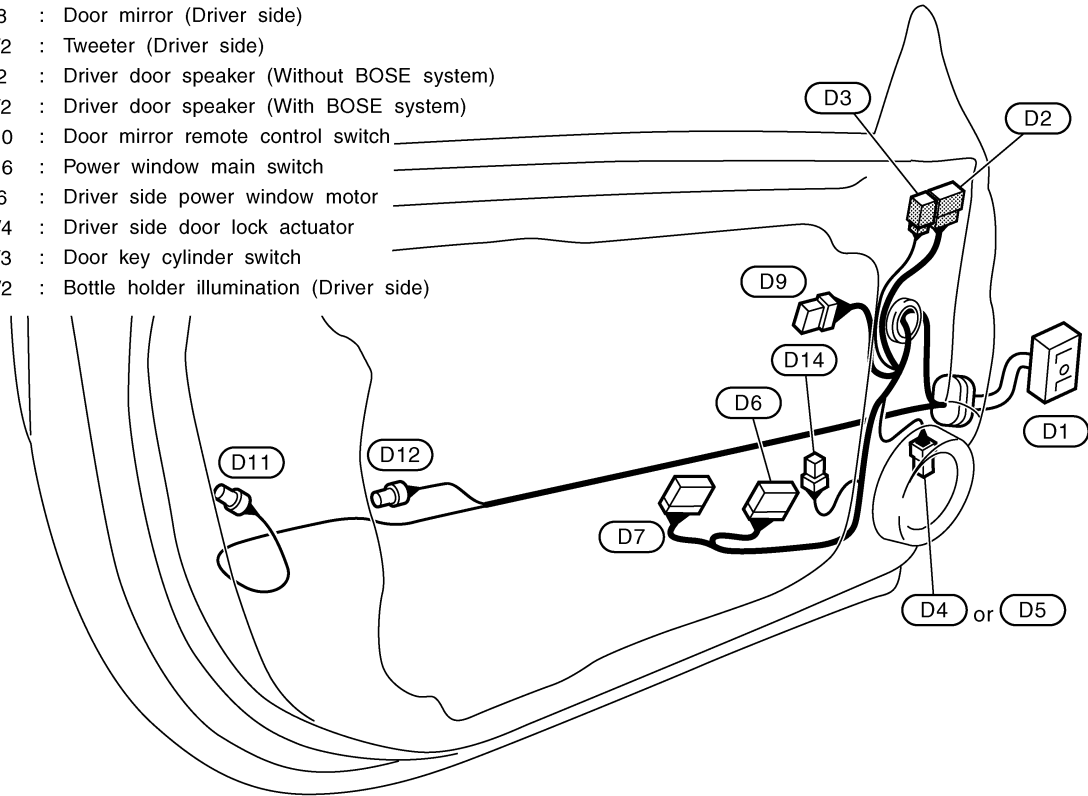

TKIT0563E

Passenger Side Door

- (D31) SMJ : To (M74)
- (D32) W/8 : Door mirror (Passenger side)
- (D33) BR/2 : Tweeter (Passenger side)
- (D34) W/2 : Passenger door speaker (Without BOSE system)
- (D35) BR/2 : Passenger door speaker (With BOSE system)
- (D37) W/16 : Power window sub-switch
- (D38) W/6 : Passenger side power window motor
- (D40) GY/4 : Passenger side door lock actuator
- (D42) GY/2 : Bottle holder illumination (Passenger side)

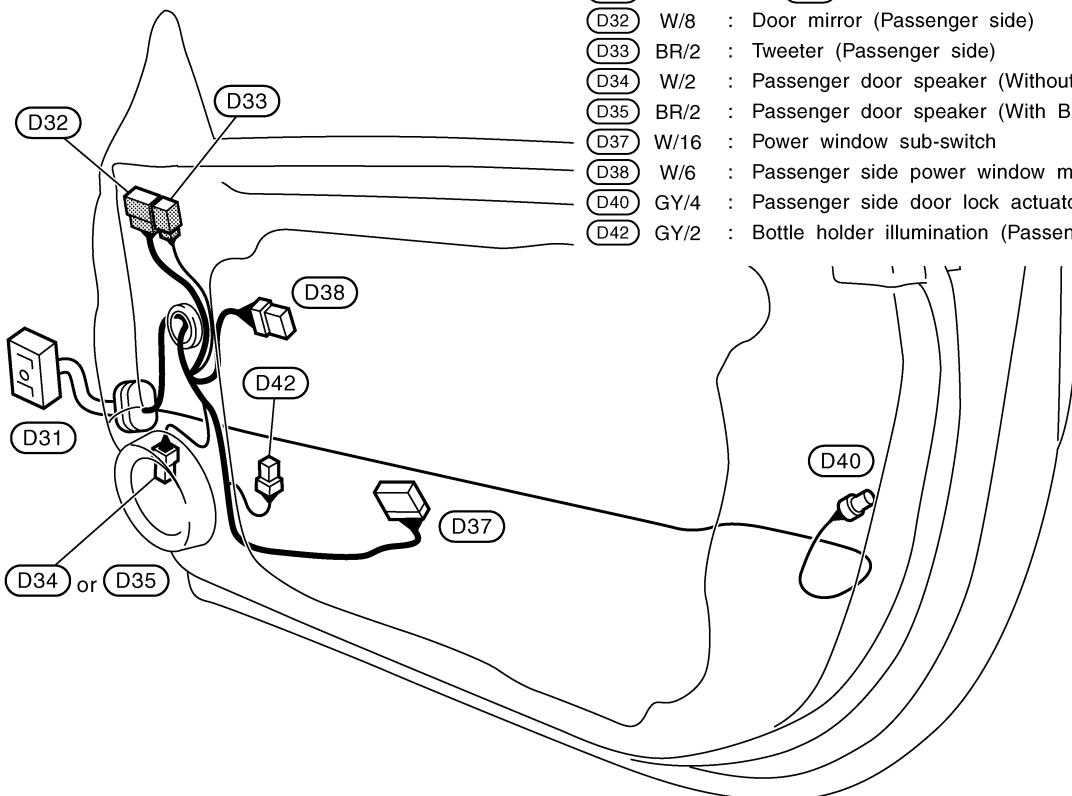

TKIT0564E

HARNESSES

Back Door

Defogger harness (-)
 (D211) B/1 : Rear window defogger (-)
 (D212) -- : Body ground

(D101) W/3 : To (B38)
 (D102) GY/2 : To (B39)
 (D103) BR/2 : High-mounted stop lamp
 (D104) B/1 : Rear window defogger
 (D105) -- : Body ground
 (D106) W/4 : Rear wiper motor

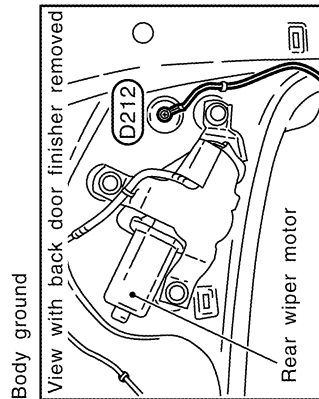
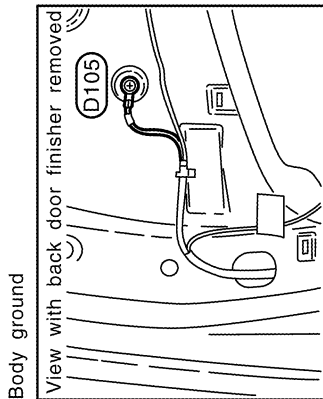
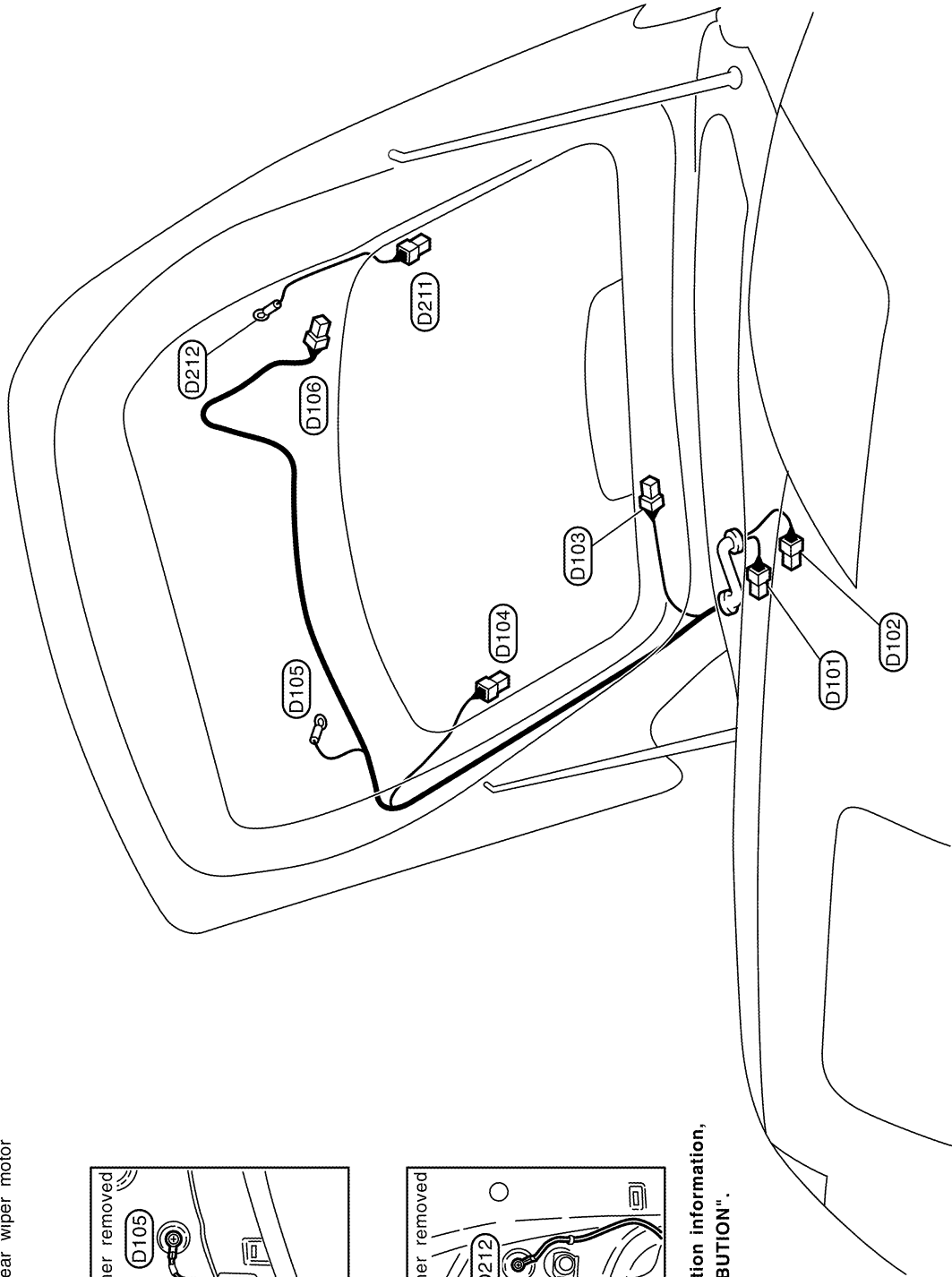

For detail ground distribution information, refer to "GROUND DISTRIBUTION".

TKIT0068E

A
 B
 C
 D
 E
 F
 G
 H
 I
 J
 PG
 L
 M

HARNESS

Wiring Diagram Codes (Cell Codes)

NKS000EH

Use the chart below to find out what each wiring diagram code stands for.

Refer to the wiring diagram code in the alphabetical index to find the location (page number) of each wiring diagram.

Code	Section	Wiring Diagram Name
3METER	DI	Triple Meter
ABS	BRC	Anti-Lock Brake System
A/C	ATC	Air Conditioner
AF1B1	EC	Air Fuel Ratio Sensor 1 Bank 1
AF1B2	EC	Air Fuel Ratio Sensor 1 Bank 2
AF1HB1	EC	Air Fuel Ratio Sensor 1 Heater Bank 1
AF1HB2	EC	Air Fuel Ratio Sensor 1 Heater Bank 2
APPS1	EC	Accelerator Pedal Position Sensor
APPS2	EC	Accelerator Pedal Position Sensor
APPS3	EC	Accelerator Pedal Position Sensor
ASC/BS	EC	Automatic Speed Control Device (ASCD) Brake Switch
ASC/SW	EC	Automatic Speed Control Device (ASCD) Steering Switch
ASCBOF	EC	Automatic Speed Control Device (ASCD) Brake Switch
ASCIND	EC	Automatic Speed Control Device (ASCD) Indicator
AT/IND	DI	A/T Indicator Lamp
AUDIO	AV	Audio
BACK/L	LT	Back-Up Lamp
BRK/SW	EC	Brake Switch
CAN	AT	CAN Communication Line
CAN	EC	CAN Communication Line
CAN	LAN	CAN System
CHARGE	SC	Charging System
CHIME	DI	Warning Chime
COMBSW	LT	Combination Switch
COMM	AV	Audio Visual Communication Line
COOL/F	EC	Cooling Fan Control
DEF	GW	Rear Window Defogger
D/LOCK	BL	Power Door Lock
DTRL	LT	Headlamp - With Daytime Light System
ECM/PW	EC	ECM Power Supply for Back-Up
ECTS	EC	Engine Coolant Temperature Sensor
EPS	STC	Electric Controlled Power Steering System
ETC1	EC	Electric Throttle Control Function
ETC2	EC	Electric Throttle Control Motor Relay
ETC3	EC	Electric Throttle Control Motor
EVCB1	EC	Exhaust Valve Timing Control Magnet Retarder (Bank 1)
EVCB2	EC	Exhaust Valve Timing Control Magnet Retarder (Bank 2)
EVCSB1	EC	Exhaust Valve Timing Control Position Sensor (Bank 1)
EVCSB2	EC	Exhaust Valve Timing Control Position Sensor (Bank 2)
F/LID	BL	Fuel Lid Opener
F/PUMP	EC	Fuel Pump

HARNESSES

Code	Section	Wiring Diagram Name
F/ROOF	RF	Soft Top
FTS	AT	A/T Fluid Temperature Sensor Circuit
FTTS	EC	Fuel Tank Temperature Sensor
FUELB1	EC	Fuel Injection System Function (Bank 1)
FUELB2	EC	Fuel Injection System Function (Bank 2)
H/LAMP	LT	Headlamp
HORN	WW	Horn
HSEAT	SE	Heated Seat
IATS	EC	Intake Air Temperature Sensor
IGNSYS	EC	Ignition System
ILL	LT	Illumination
I/MIRR	GW	Inside Mirror (Auto Anti-Dazzling Mirror)
INJECT	EC	Injector
IVCB1	EC	Intake Valve Timing Control Solenoid Valve Bank 1
IVCB2	EC	Intake Valve Timing Control Solenoid Valve Bank 2
KEYLES	BL	Remote Keyless Entry System
KS	EC	Knock Sensor
MAFS	EC	Mass Air Flow Sensor
MAIN	AT	Main Power Supply and Ground Circuit
MAIN	EC	Main Power Supply and Ground Circuit
M/ANT	AV	Manual Antenna
METER	DI	Speedometer, Tachometer, Temp. and Fuel Gauges
MIL/DL	EC	MIL & Data Link Connector
MIRROR	GW	Power Door Mirror
MMSW	AT	Manual Mode Switch
NATS	BL	Nissan Anti-Theft System
NAVI	AV	Navigation System
NONDTC	AT	Non-Detective Items
O2H2B1	EC	Heated Oxygen Sensor 2 Heater Bank 1
O2H2B2	EC	Heated Oxygen Sensor 2 Heater Bank 2
O2S2B1	EC	Heated Oxygen Sensor 2 Bank 1
O2S2B2	EC	Heated Oxygen Sensor 2 Bank 2
PGC/V	EC	EVAP Canister Purge Volume Control Solenoid Valve
PHSB1	EC	Camshaft Position Sensor (PHASE) (Bank 1)
PHSB2	EC	Camshaft Position Sensor (PHASE) (Bank 2)
PNP/SW	AT	Park/Neutral Position Switch
PNP/SW	EC	Park/Neutral Position Switch
POS	EC	Crankshaft Position Sensor (CKPS) (POS)
POWER	PG	Power Supply Routing
PRE/SE	EC	EVAP Control System Pressure Sensor
P/SCKT	WW	Power Socket
PS/SEN	EC	Power Steering Pressure Sensor
ROOM/L	LT	Interior Room Lamp
RP/SEN	EC	Refrigerant Pressure Sensor

A
B
C
D
E
F
G
H
I
J
L
M

PG

HARNESS

Code	Section	Wiring Diagram Name
SEAT	SE	Power Seat
SEN/PW	EC	Sensor Power Supply
SHIFT	AT	A/T Shift Lock System
SRS	SRS	Supplemental Restraint System
START	SC	Starting System
STOP/L	LT	Stop Lamp
STSIG	AT	Start Signal Circuit
TAIL/L	LT	Parking, License and Tail Lamps
TCS	BRC	Traction Control System
TLID	BL	Trunk Lid Opener
TPS1	EC	Throttle Position Sensor (Sensor 1)
TPS2	EC	Throttle Position Sensor (Sensor 2)
TPS3	EC	Throttle Position Sensor
TRNSCV	BL	Homelink Universal Transceiver
TURN	LT	Turn Signal and Hazard Warning Lamp
T/WARN	WT	Low Tire Pressure Warning System
VDC	BRC	Vehicle Dynamics Control System
VEHSEC	BL	Vehicle Security System
VENT/V	EC	EVAP Canister Vent Control Valve
VSSA/T	AT	Vehicle Speed Sensor A/T (Revolution Sensor)
WARN	DI	Warning Lamps
WINDOW	GW	Power Window
WIPER	WW	Front Wiper and Washer
WIP/R	WW	Rear Wiper and Washer

ELECTRICAL UNITS LOCATION

ELECTRICAL UNITS LOCATION

PPF:25230

Electrical Units Location ENGINE COMPARTMENT

NKS000E1

IPDM E/R (Intelligent power distribution module engine room)

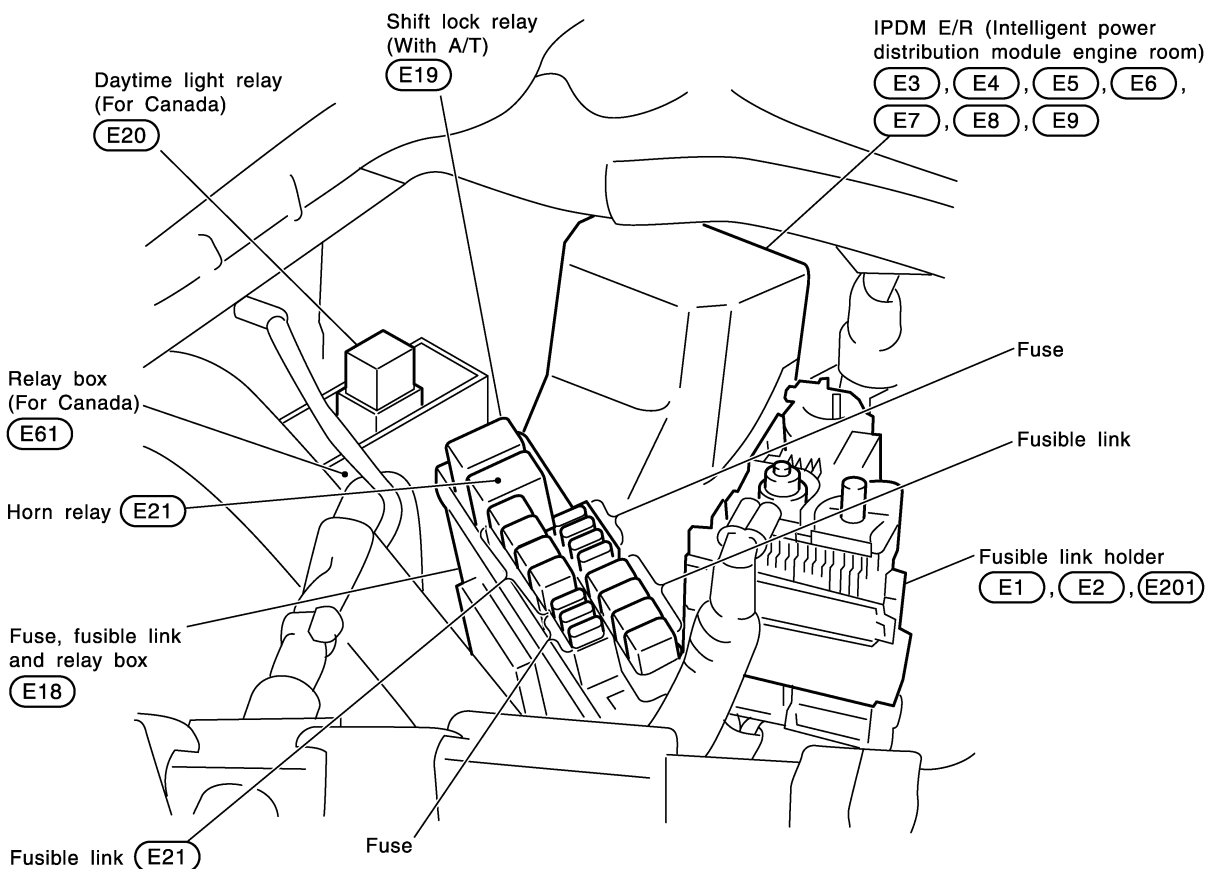
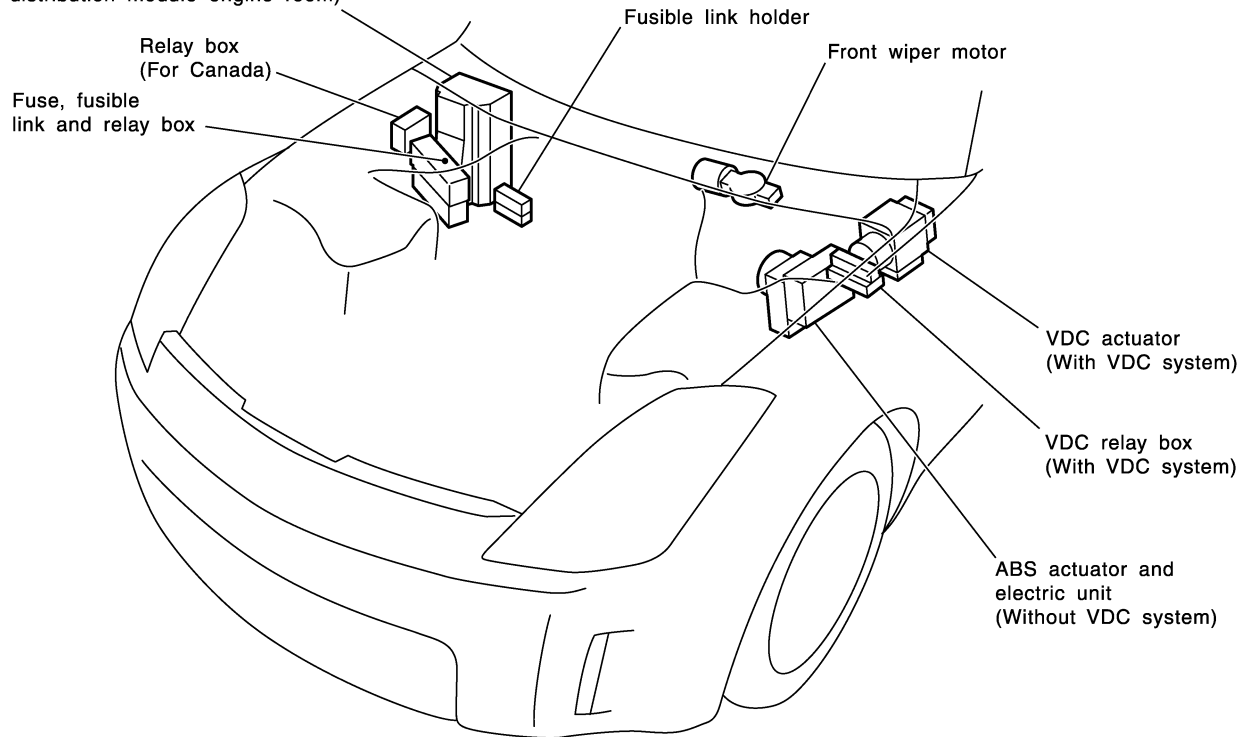

CKIT0739E

ELECTRICAL UNITS LOCATION

PASSENGER COMPARTMENT/TYPE 1

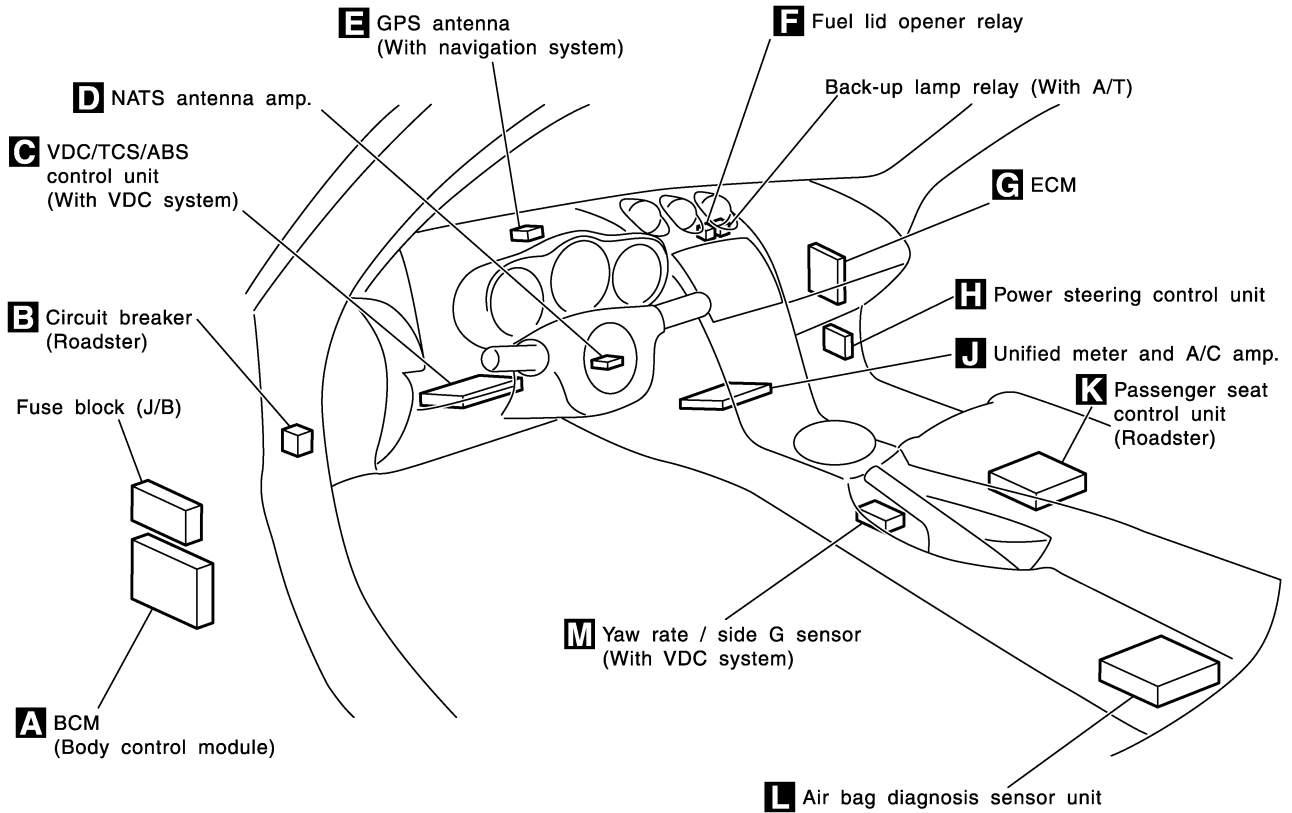

A Behind the dash side lower LH finisher

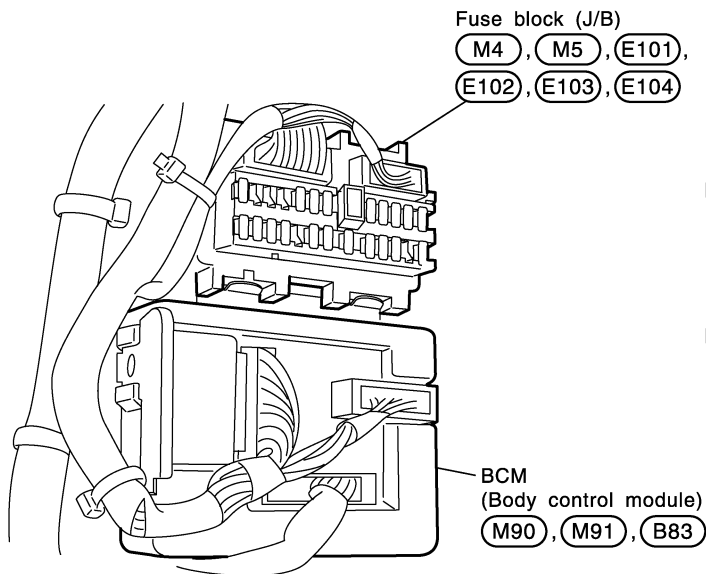

Fuse block (J/B) rear view

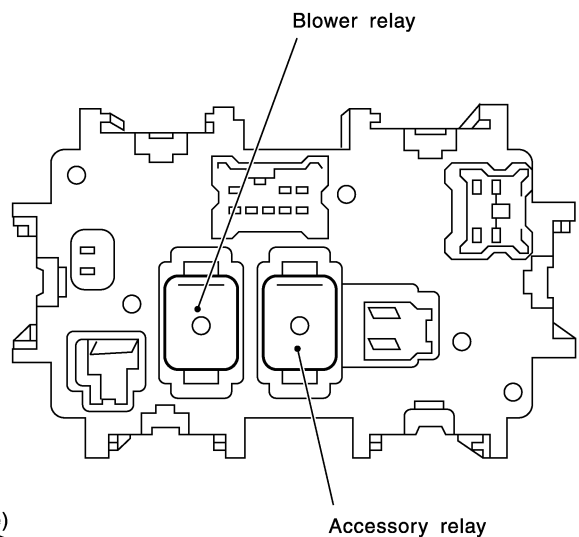

CKIT0740E

ELECTRICAL UNITS LOCATION

<p>B Driver side view with instrument lower panel removed</p> <p>Circuit breaker B55</p>	<p>C Driver side view with instrument lower panel removed</p> <p>VDC/TCS/ABS control unit E118</p>	<p>D View with steering column cover removed</p> <p>NATS antenna amp. M28 Ignition key cylinder</p>
<p>E Driver side view with instrument upper panel removed</p> <p>GPS antenna</p>	<p>F View with instrument panel removed</p> <p>Blower motor Fuel lid opener relay M59</p>	<p>G Blower motor RH side</p> <p>ECM (F101)</p>
<p>H Behind the dash side lower RH finisher</p> <p>Power steering control unit F104</p>	<p>J View with console finisher removed</p> <p>Unified meter and A/C amp. M48, M49, M50</p>	<p>K Under passenger seat</p> <p>Front Passenger seat control unit B353, B354</p>
<p>L View with floor console box removed</p> <p>Parking brake lever Air bag diagnosis sensor unit M55, B13, B14</p>	<p>M View with floor console box removed</p> <p>parking brake lever Yaw rate / side G sensor M51</p>	

A
B
C
D
E
F
G
H
I
J
K
L
M

PG

CKIT0741E

ELECTRICAL UNITS LOCATION

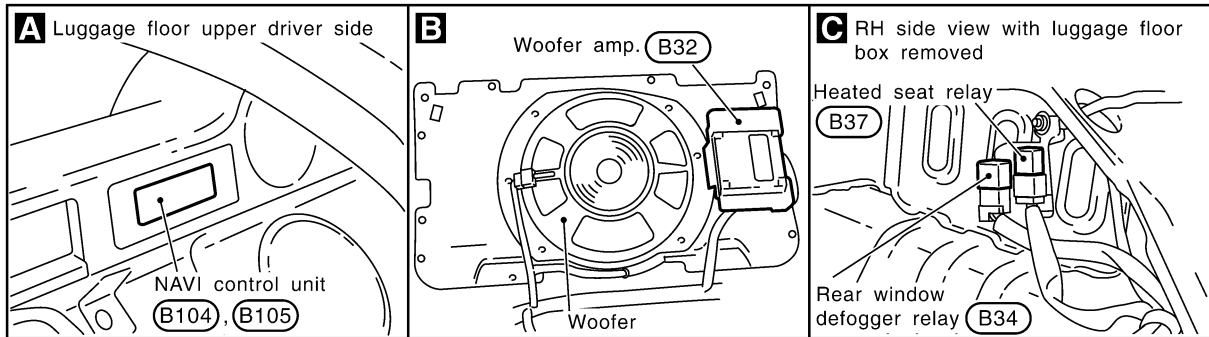
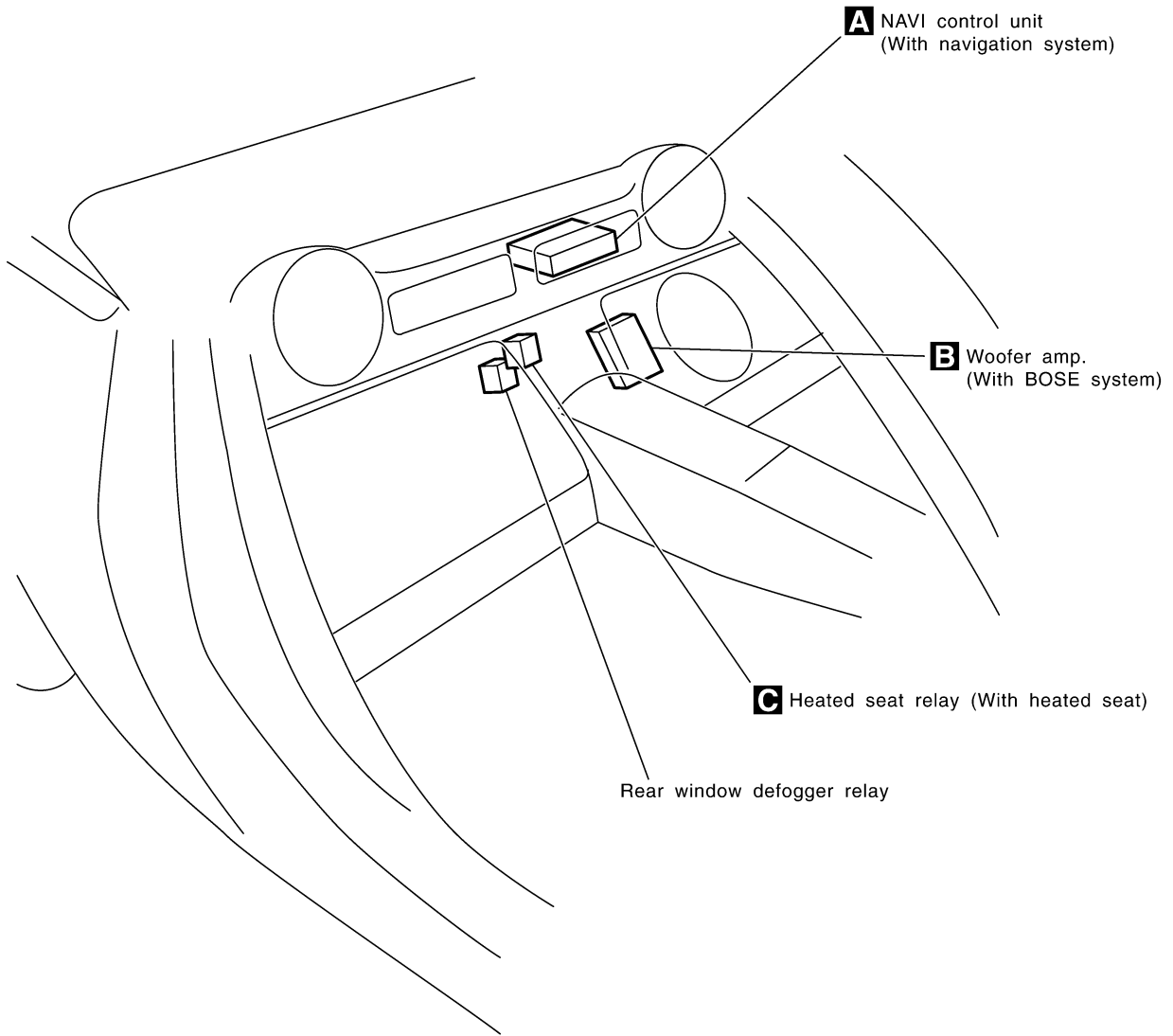

CKIT0349E

ELECTRICAL UNITS LOCATION

PASSENGER COMPARTMENT/TYPE 2

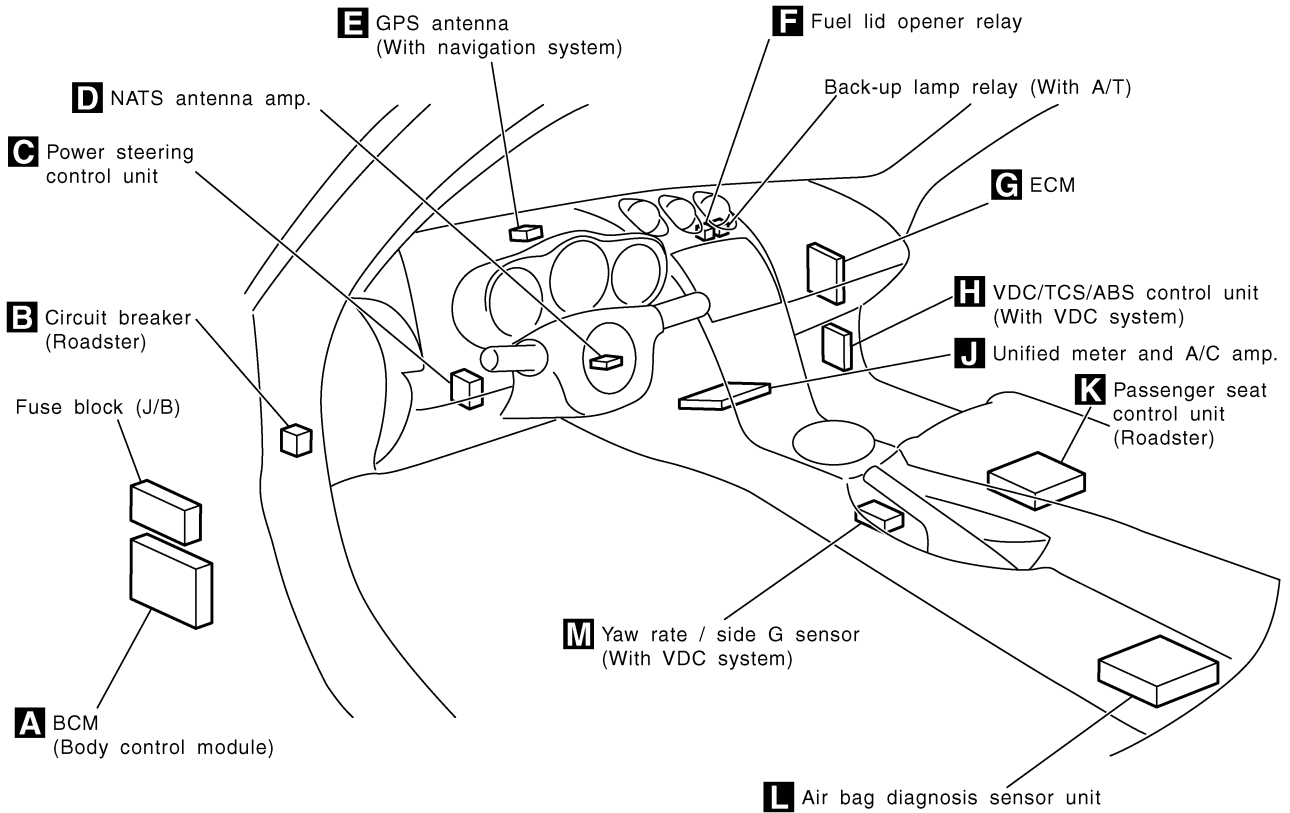

A
B
C
D
E
F
G
H
I
J

A Behind dash side lower LH finisher

Fuse block (J/B) rear view

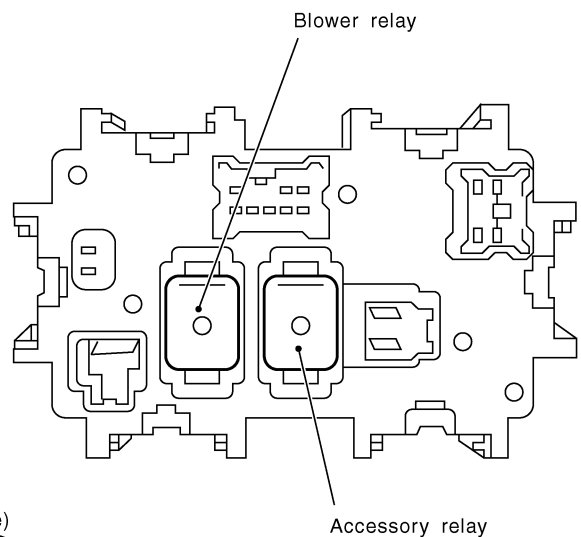
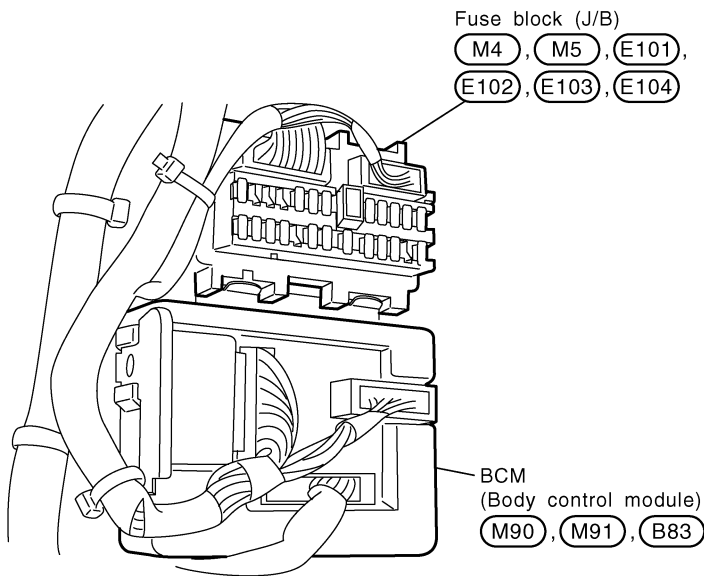

PG

L
M

CKIT0860E

ELECTRICAL UNITS LOCATION

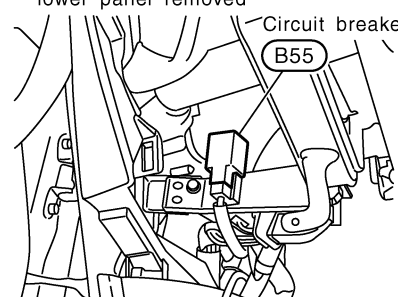
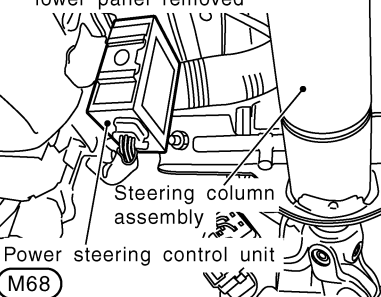
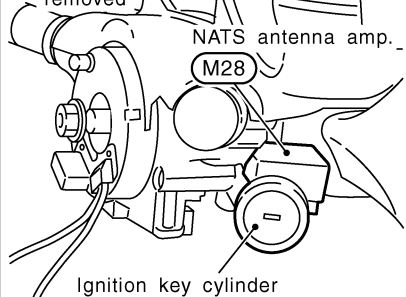
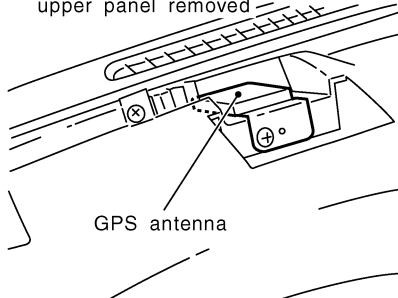
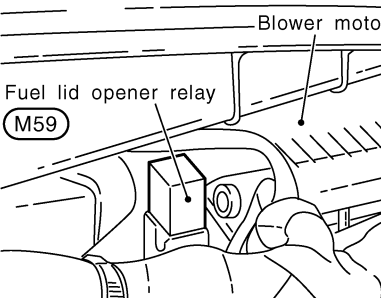
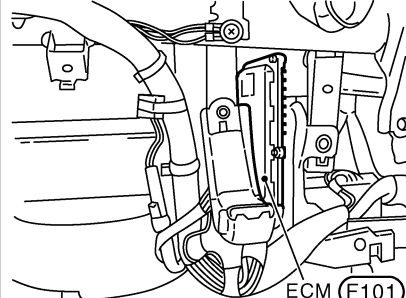
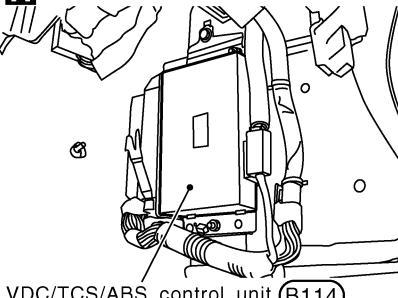
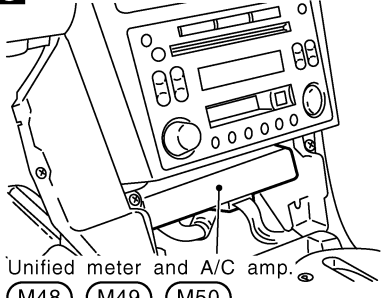
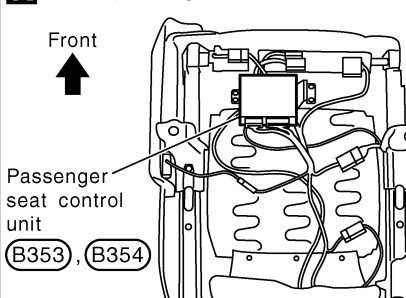
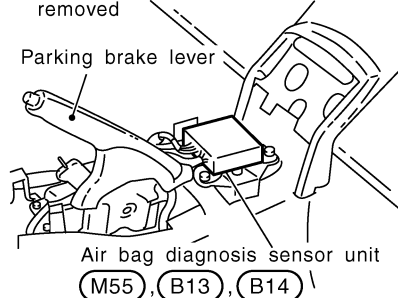
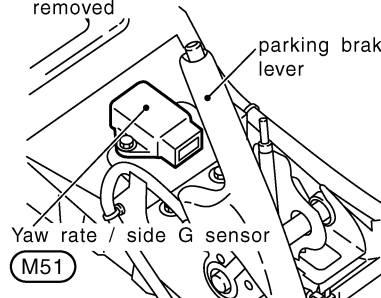
<p>B Driver side view with instrument lower panel removed</p>  <p>Circuit breaker B55</p>	<p>C Driver side view with instrument lower panel removed</p>  <p>Steering column assembly Power steering control unit M68</p>	<p>D View with steering column cover removed</p>  <p>NATS antenna amp. M28 Ignition key cylinder</p>
<p>E Driver side view with instrument upper panel removed</p>  <p>GPS antenna</p>	<p>F View with instrument panel removed</p>  <p>Blower motor Fuel lid opener relay M59</p>	<p>G Blower motor RH side</p>  <p>ECM (F101)</p>
<p>H Behind dash side lower RH finisher</p>  <p>VDC/TCS/ABS control unit B114</p>	<p>J View with console finisher removed</p>  <p>Unified meter and A/C amp. M48, M49, M50</p>	<p>K Under passenger seat</p>  <p>Front Passenger seat control unit B353, B354</p>
<p>L View with floor console box removed</p>  <p>Parking brake lever Air bag diagnosis sensor unit M55, B13, B14</p>	<p>M View with floor console box removed</p>  <p>parking brake lever Yaw rate / side G sensor M51</p>	

CKIT0861E

ELECTRICAL UNITS LOCATION

A
B
C
D
E
F
G
H
I
J
PG
L
M

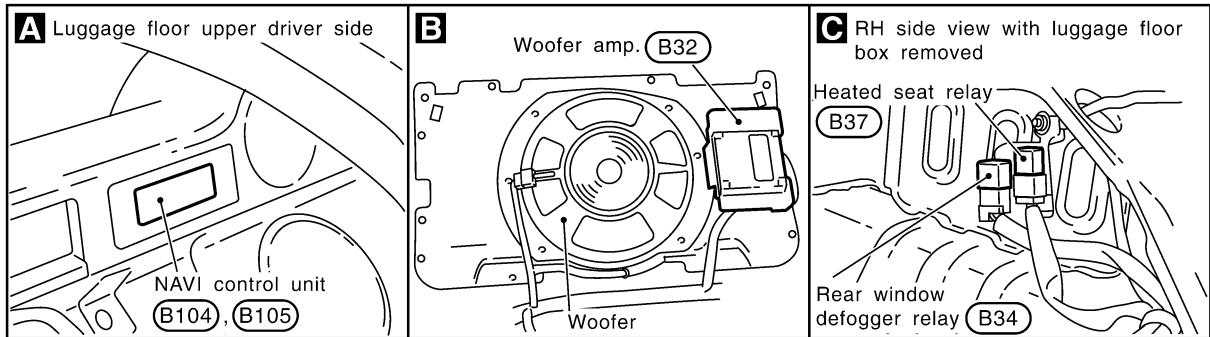
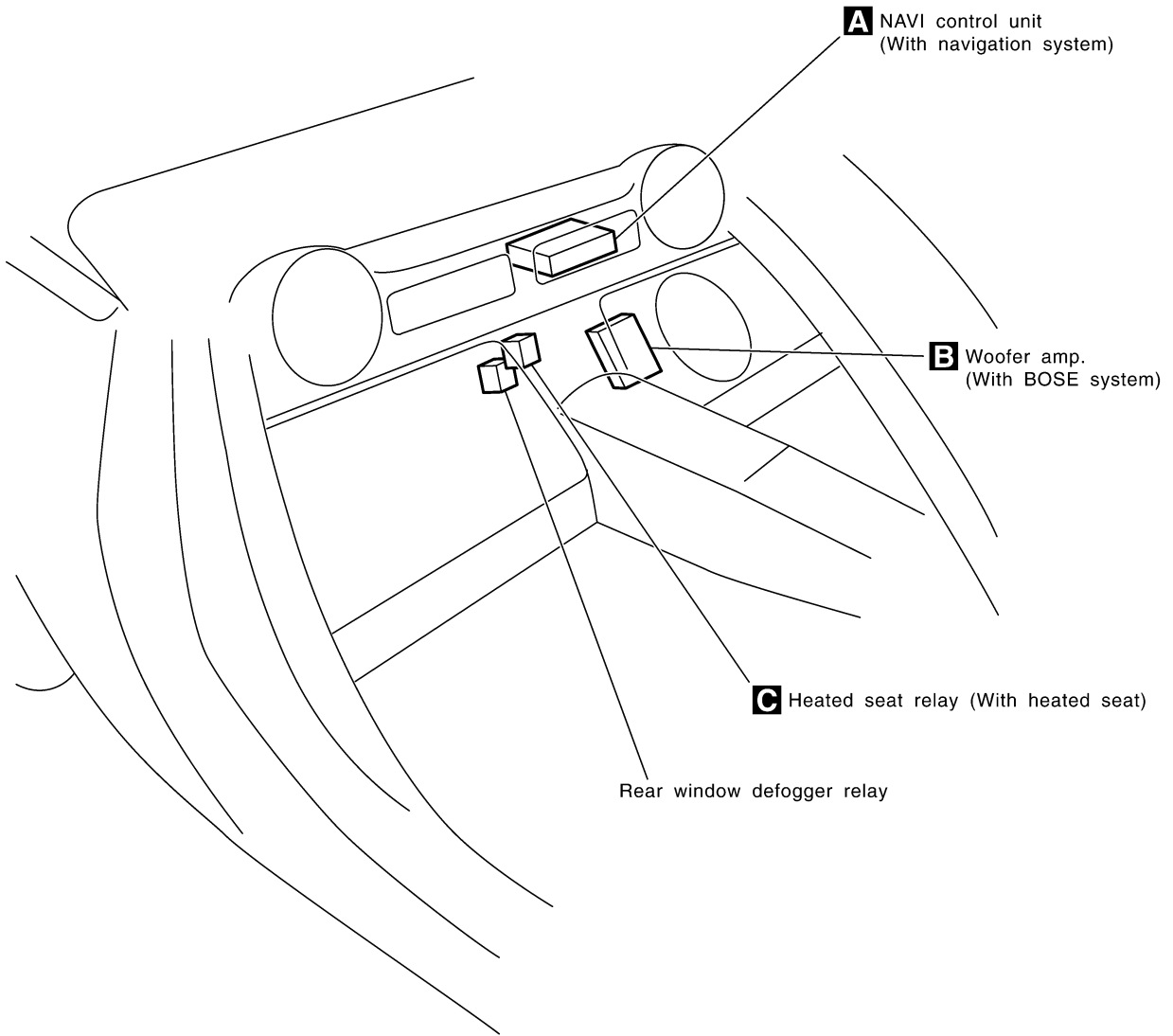

CKIT0349E

ELECTRICAL UNITS LOCATION

LUGGAGE COMPARTMENT

Coupe Models

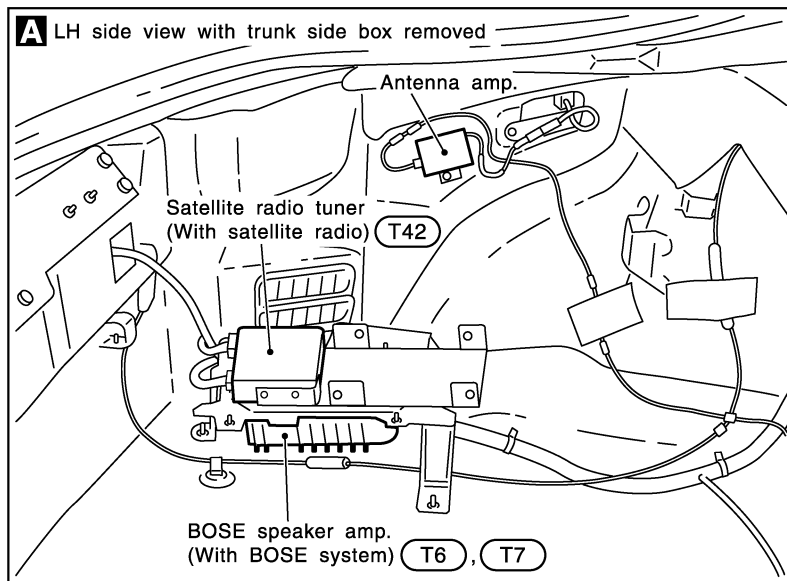
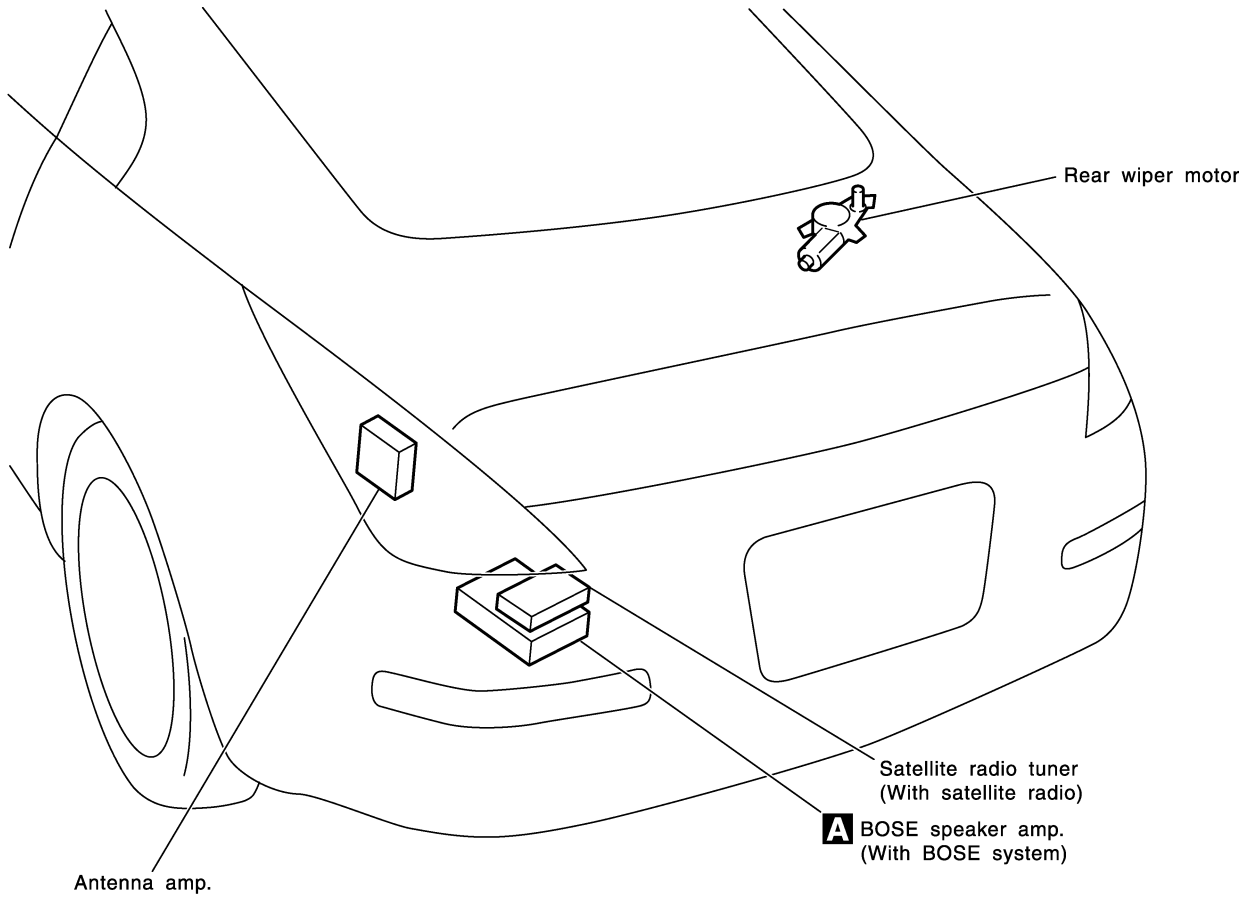

CKIT0742E

ELECTRICAL UNITS LOCATION

Roadster Models

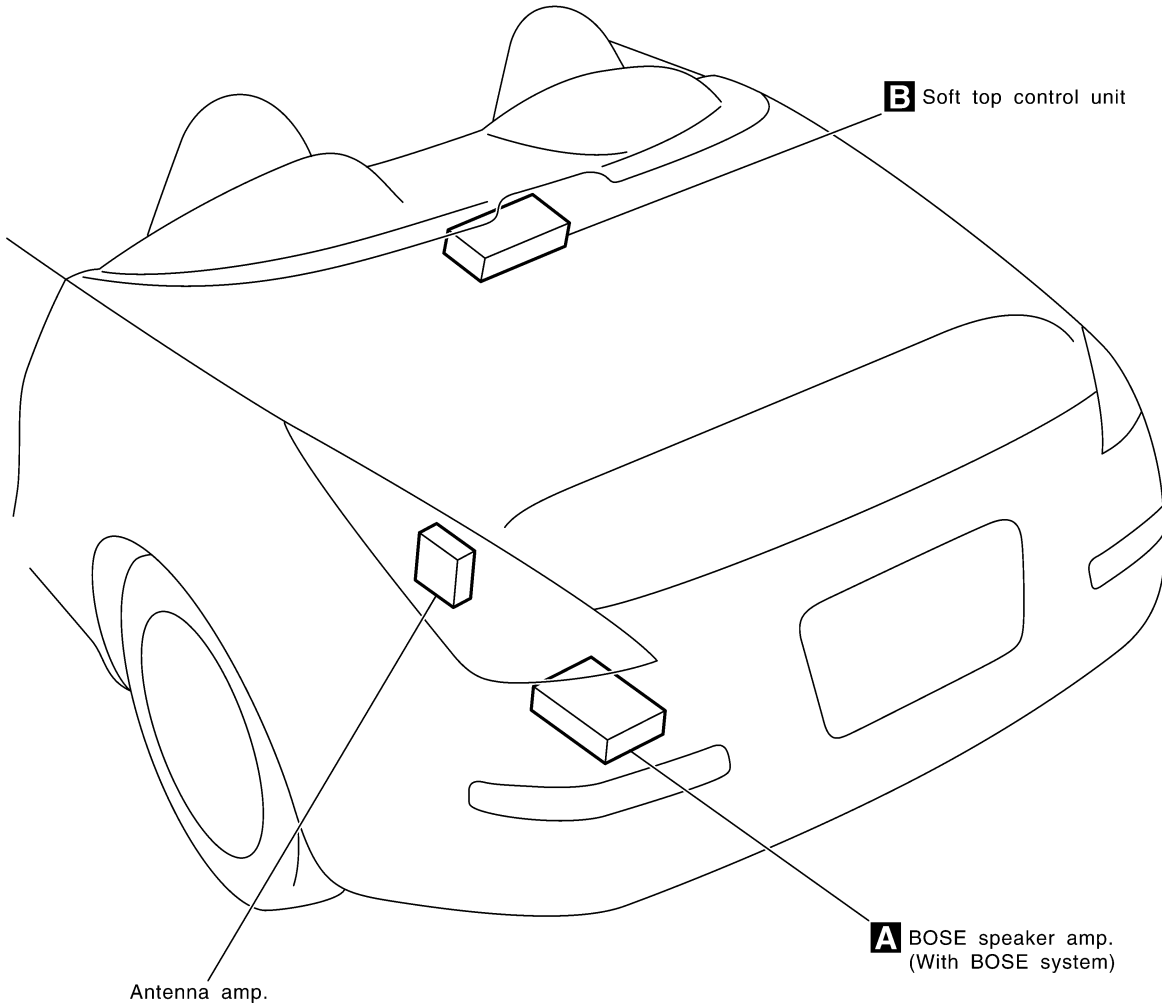

A
B
C
D
E
F
G
H
I
J

PG

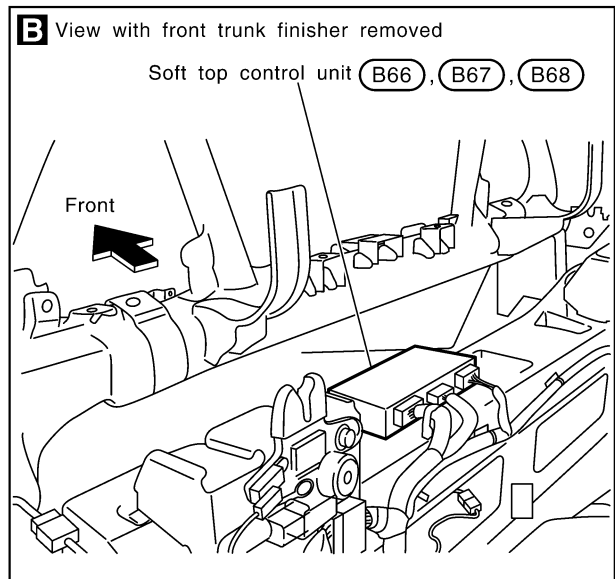
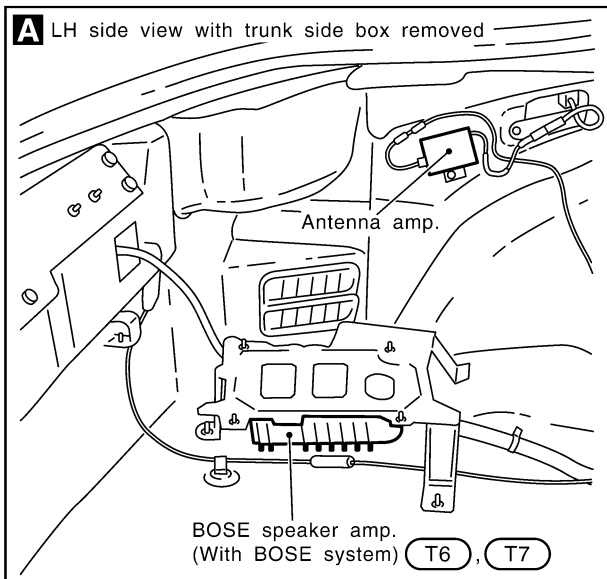

L
M

CKIT0350E

HARNESS CONNECTOR

HARNESS CONNECTOR

PFP:00011

Description

HARNESS CONNECTOR (TAB-LOCKING TYPE)

NKS004SA

- The tab-locking type connectors help prevent accidental looseness or disconnection.
- The tab-locking type connectors are disconnected by pushing or lifting the locking tab(s). Refer to the figure below.

Refer to the next page for description of the slide-locking type connector.

CAUTION:

Never pull the harness or wires when disconnecting the connector.

[Example]

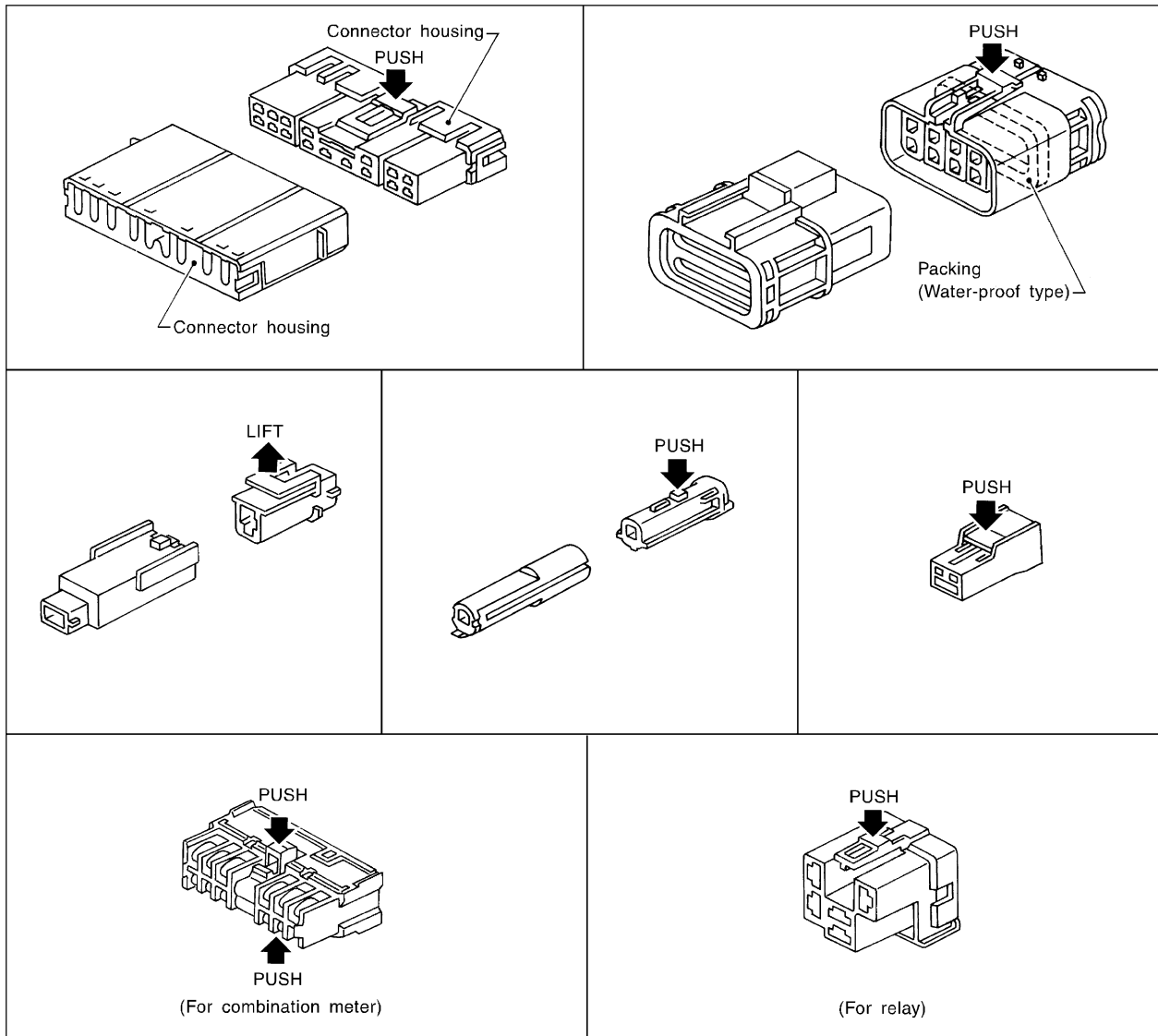

SEL769DA

HARNESS CONNECTOR

HARNESS CONNECTOR (SLIDE-LOCKING TYPE)

- A new style slide-locking type connector is used on certain systems and components, especially those related to OBD.
- The slide-locking type connectors help prevent incomplete locking and accidental looseness or disconnection.
- The slide-locking type connectors are disconnected by pushing or pulling the slider. Refer to the figure below.

CAUTION:

- **Never pull the harness or wires when disconnecting the connector.**
- **Be careful not to damage the connector support bracket when disconnecting the connector.**

[Example]

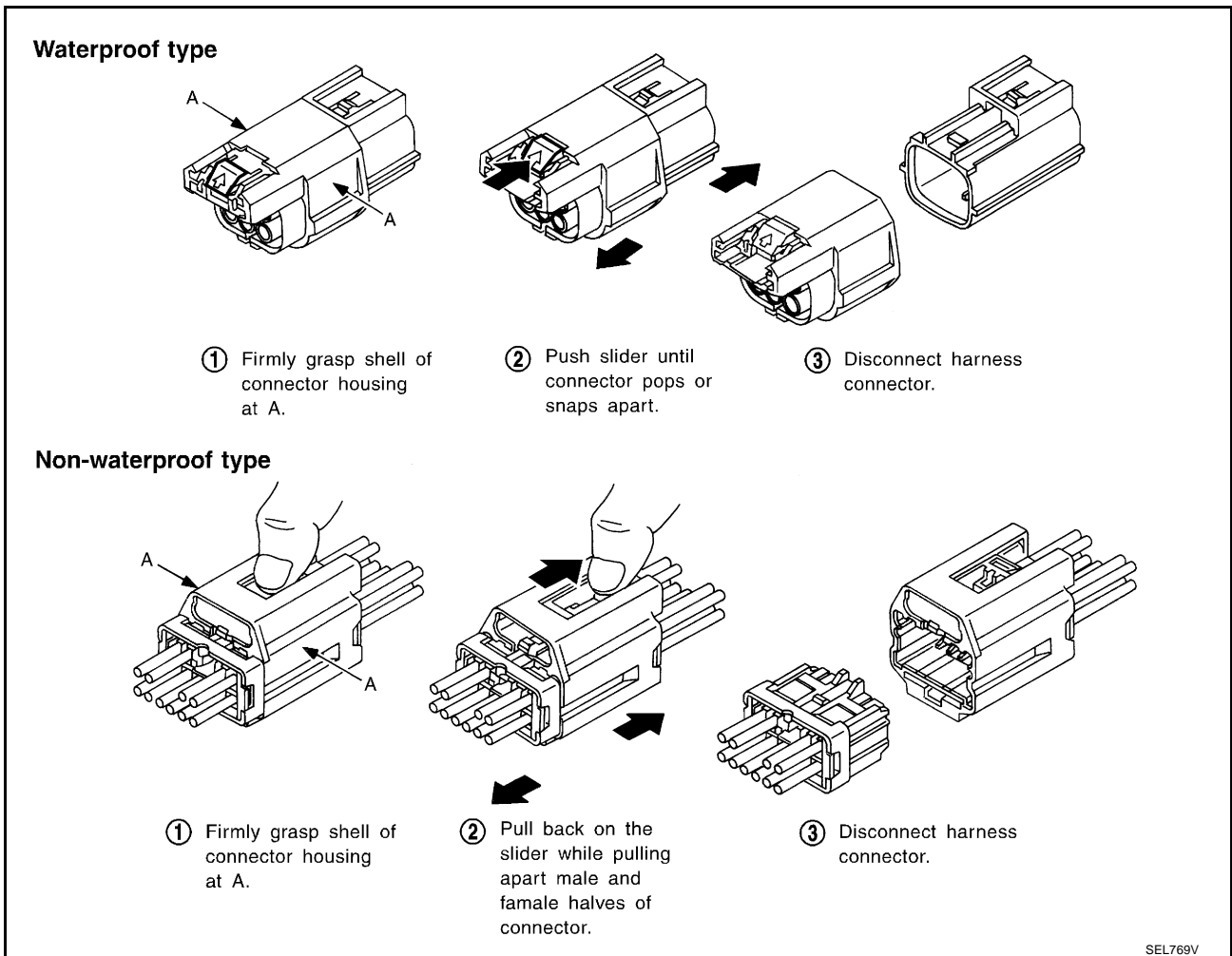

A
B
C
D
E
F
G
H
I
J
PG
L
M

HARNESS CONNECTOR

HARNESS CONNECTOR (LEVER LOCKING TYPE)

- Lever locking type harness connectors are used on certain control units and control modules such as ECM, ABS actuator and electric unit (control unit), etc.
- Lever locking type harness connectors are also used on super multiple junction (SMJ) connectors.
- Always confirm the lever is fully locked in place by moving the lever as far as it will go to ensure full connection.

CAUTION:

Always confirm the lever is fully released (loosened) before attempting to disconnect or connect these connectors to avoid damage to the connector housing or terminals.

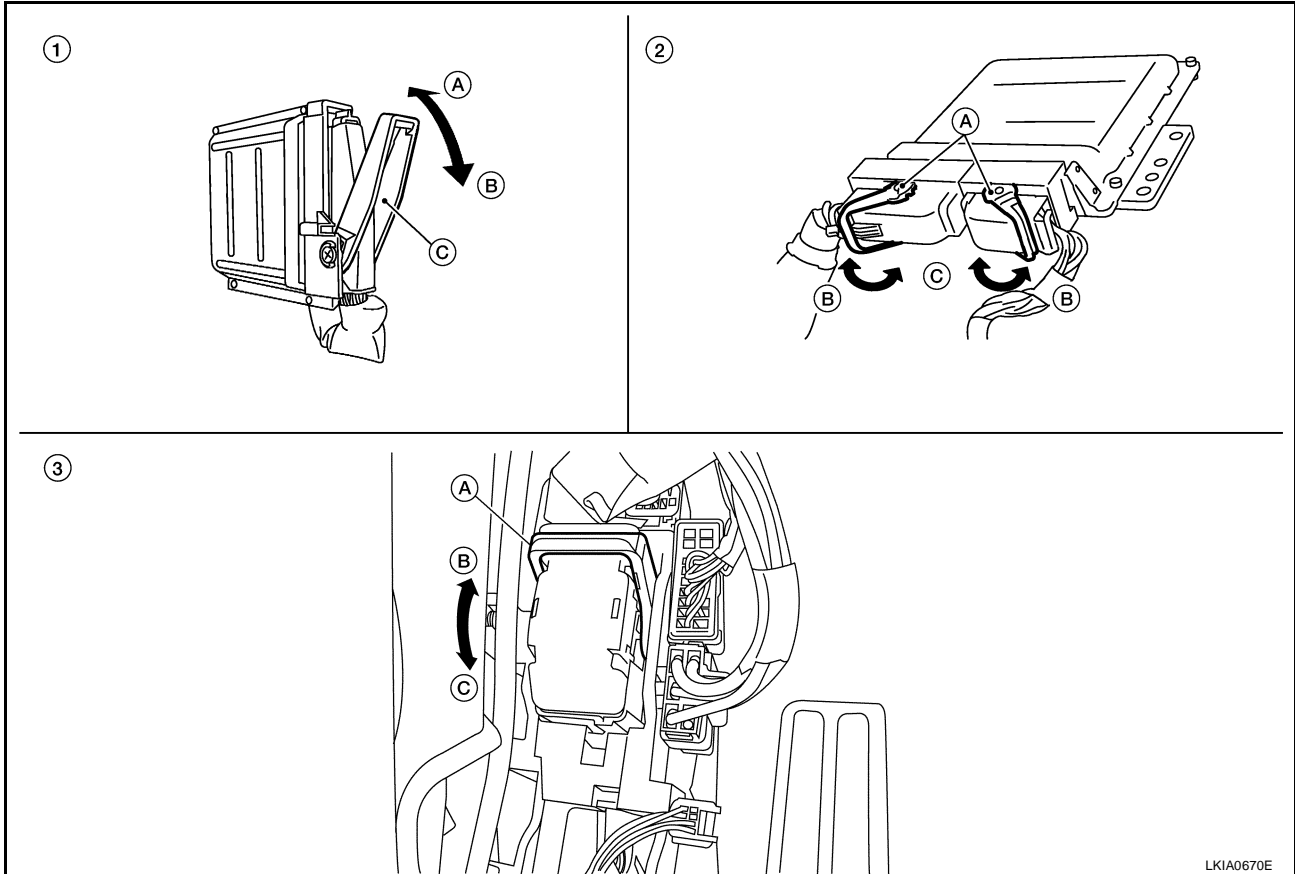

LKIA0670E

- | | | |
|-----------------------------------|----------------------------------|------------------|
| 1. Control unit with single lever | 2. Control unit with dual levers | 3. SMJ connector |
| A. Fasten | A. Levers | A. Lever |
| B. Loosen | B. Fasten | B. Fasten |
| C. Lever | C. Loosen | C. Loosen |

ELECTRICAL UNITS

ELECTRICAL UNITS

Terminal Arrangement/Type 1

PPF:00011

NKS000EK

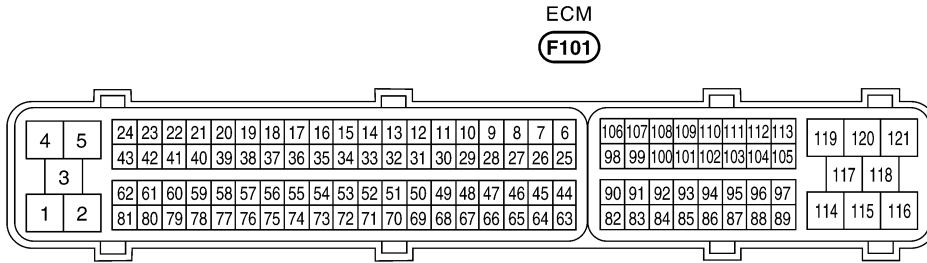

(Black)

ABS ACTUATOR AND ELECTRIC UNIT (CONTROL UNIT)

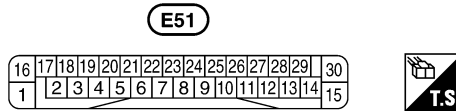

(Gray)

VDC/TCS/ABS CONTROL UNIT

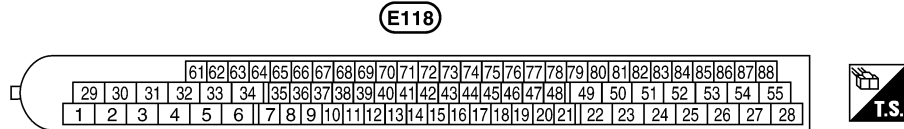

(Black)

UNIFIED METER AND A/C AMP.

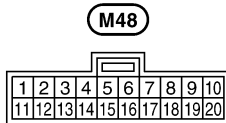

(Gray)

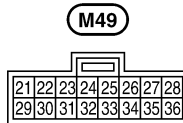

(Gray)

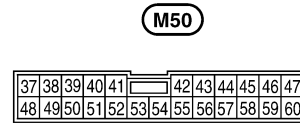

(White)

ELECTRICAL UNITS

BCM (BODY CONTROL MODULE)

M90

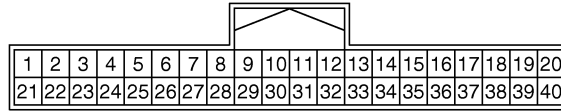

(White)

M91

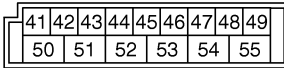

(Black)

B83

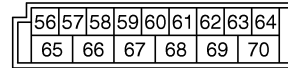

(White)

CKIT0647E

ELECTRICAL UNITS

Terminal Arrangement/Type 2

NKS004SB

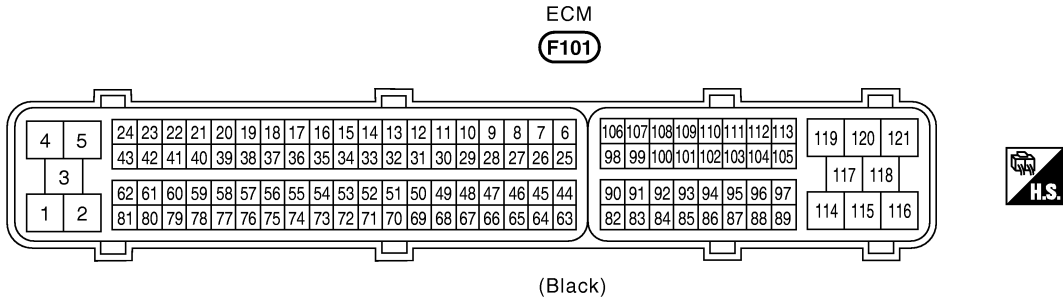

ABS ACTUATOR AND ELECTRIC UNIT (CONTROL UNIT)

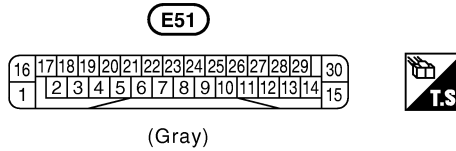

VDC/TCS/ABS CONTROL UNIT

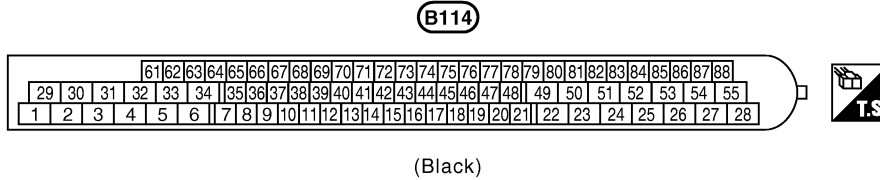

UNIFIED METER AND A/C AMP.

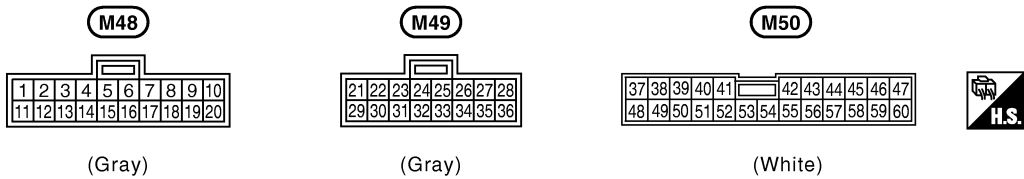

CKIT0862E

ELECTRICAL UNITS

BCM (BODY CONTROL MODULE)

M90

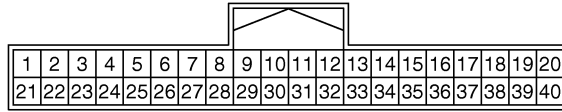

(White)

M91

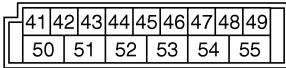

(Black)

B83

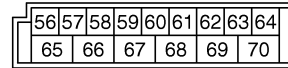

(White)

CKIT0647E

SMJ (SUPER MULTIPLE JUNCTION)

SMJ (SUPER MULTIPLE JUNCTION)

Terminal Arrangement

PF:P:B4341

NKS000EL

MAIN HARNESS

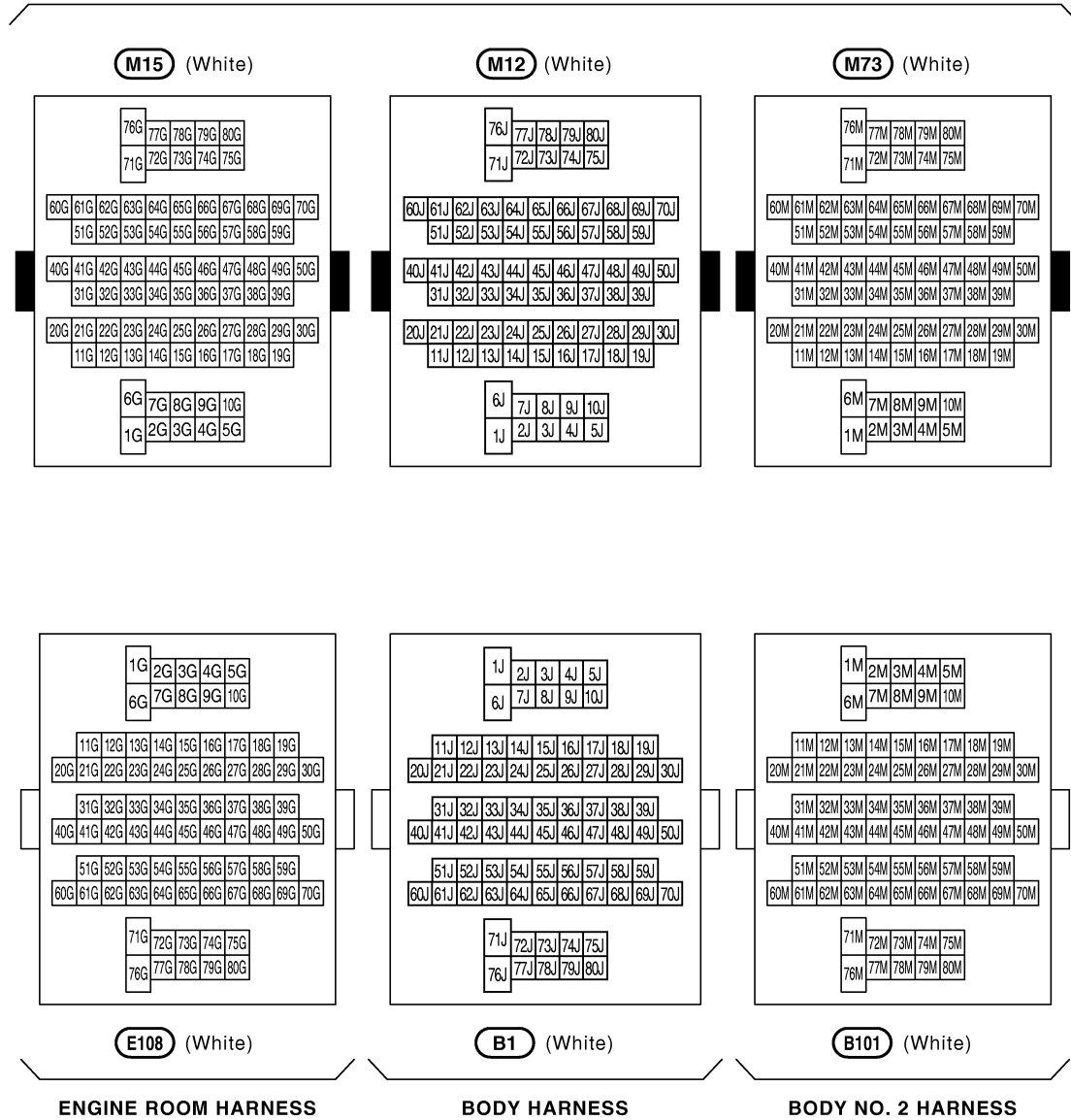

A
B
C
D
E
F
G
H
I
J
PG
L
M

CKIT0743E

SMJ (SUPER MULTIPLE JUNCTION)



MAIN HARNESS

M72 (White)

6H	7H	8H	9H	10H	21H	22H	23H	24H	25H	26H	27H	28H	29H	39H	40H	41H	42H	43H	44H	45H	46H		
1H	2H	3H	4H	5H	11H	12H	13H	14H	15H	16H	17H	18H	19H	20H	30H	31H	32H	33H	34H	35H	36H	37H	38H

1H	2H	3H	4H	5H	11H	12H	13H	14H	15H	16H	17H	18H	19H	20H	30H	31H	32H	33H	34H	35H	36H	37H	38H
6H	7H	8H	9H	10H	21H	22H	23H	24H	25H	26H	27H	28H	29H	39H	40H	41H	42H	43H	44H	45H	46H		

F102 (White)

ENGINE CONTROL HARNESS



MAIN HARNESS

M11 (White)

20K	21K	22K	23K	24K	25K	26K	27K	36K	37K	38K	39K		
11K	12K	13K	14K	15K	16K	17K	18K	19K	32K	33K	34K	35K	
1K	2K	3K	4K	5K	6K	7K	8K	9K	10K	28K	29K	30K	31K

M74 (White)

20L	21L	22L	23L	24L	25L	26L	27L	36L	37L	38L	39L		
11L	12L	13L	14L	15L	16L	17L	18L	19L	32L	33L	34L	35L	
1L	2L	3L	4L	5L	6L	7L	8L	9L	10L	28L	29L	30L	31L

1K	2K	3K	4K	5K	6K	7K	8K	9K	10K	28K	29K	30K	31K
11K	12K	13K	14K	15K	16K	17K	18K	19K	32K	33K	34K	35K	
20K	21K	22K	23K	24K	25K	26K	27K	36K	37K	38K	39K		

1L	2L	3L	4L	5L	6L	7L	8L	9L	10L	28L	29L	30L	31L
11L	12L	13L	14L	15L	16L	17L	18L	19L	32L	33L	34L	35L	
20L	21L	22L	23L	24L	25L	26L	27L	36L	37L	38L	39L		

D1 (White)

FRONT DOOR HARNESS (DRIVER SIDE)

D31 (White)

FRONT DOOR HARNESS (PASSENGER SIDE)

CKIT0158E

STANDARDIZED RELAY

PPF:00011

NKS000EM

STANDARDIZED RELAY

Description

NORMAL OPEN, NORMAL CLOSED AND MIXED TYPE RELAYS

Relays can mainly be divided into three types: normal open, normal closed and mixed type relays.

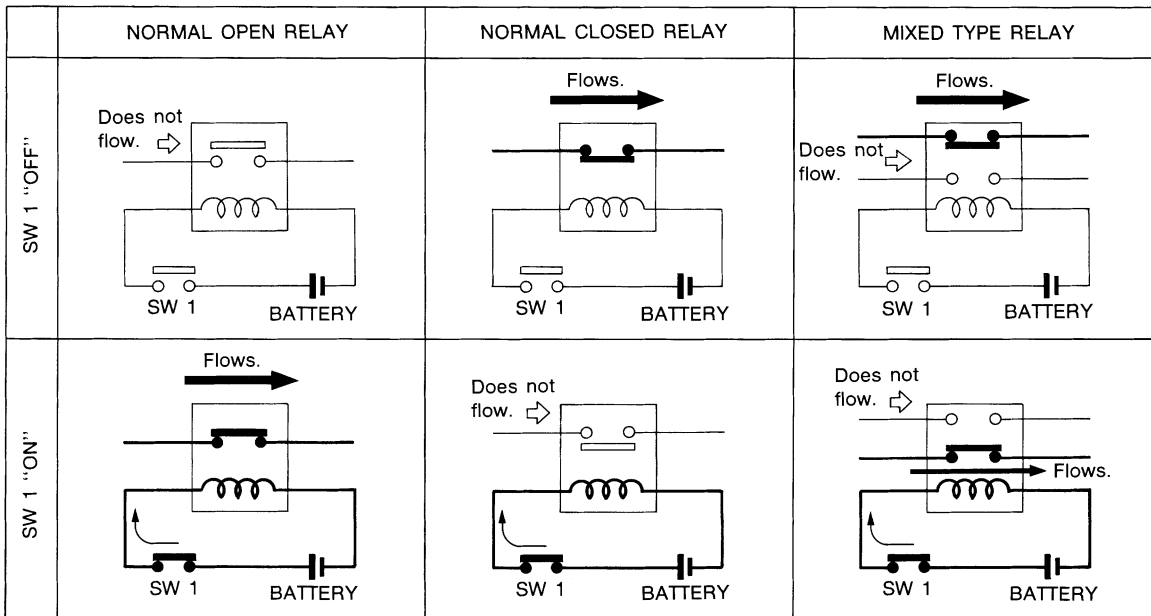

SEL881H

TYPE OF STANDARDIZED RELAYS

- 1M 1 Make
- 2M 2 Make
- 1T 1 Transfer
- 1M·1B 1 Make 1 Break

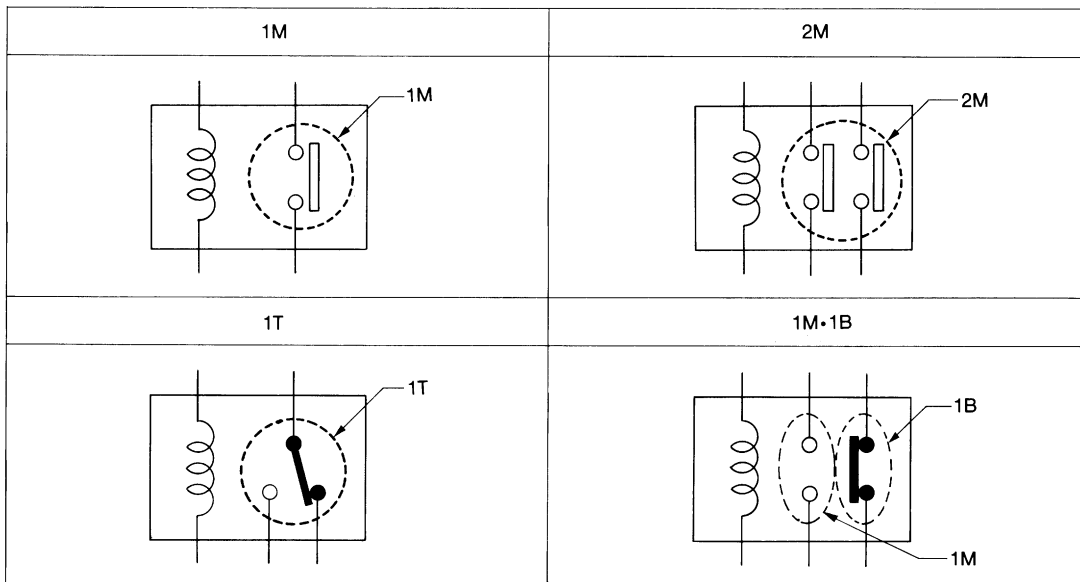

SEL882H

A
B
C
D
E
F
G
H
I
J

PG

L
M

STANDARDIZED RELAY

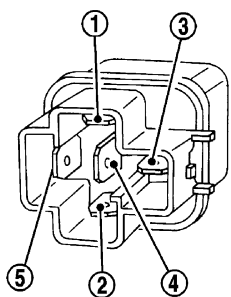
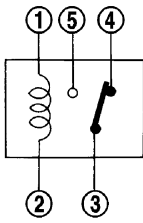
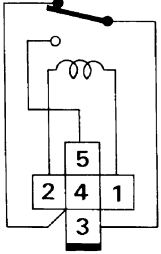
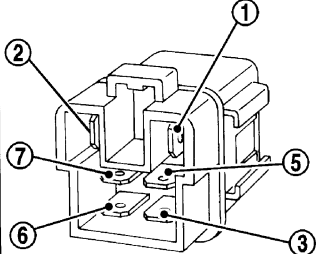
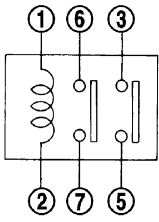
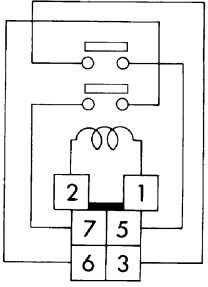
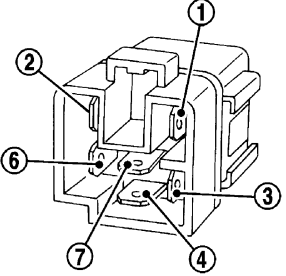
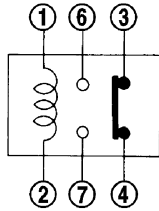
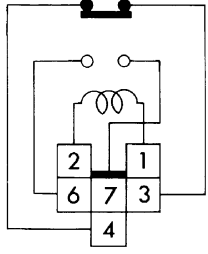
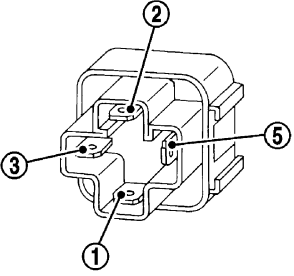
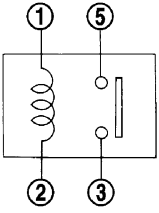
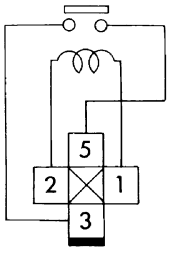
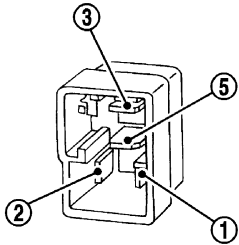
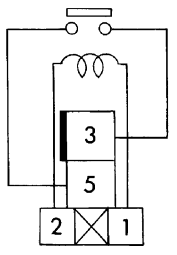
Type	Outer view	Circuit	Connector symbol and connection	Case color
1T				BLACK
2M				BROWN
1M•1B				GRAY
1M				BLUE
				

The arrangement of terminal numbers on the actual relays may differ from those shown above.

SEL188W

FUSE BLOCK - JUNCTION BOX (J/B)

FUSE BLOCK - JUNCTION BOX (J/B)

PPF:24350

Terminal Arrangement

NKS000EN

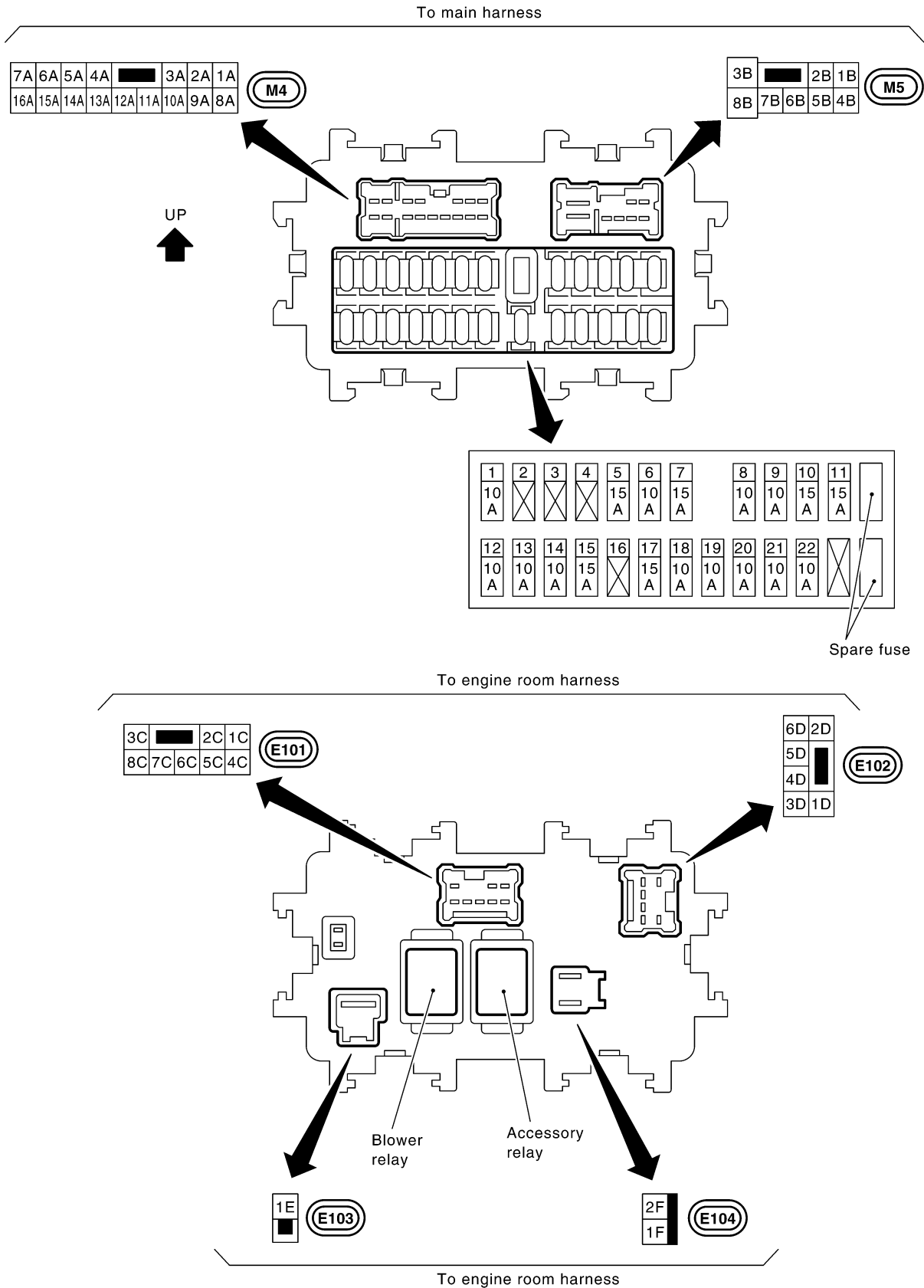

A
B
C
D
E
F
G
H
I
J
PG
L
M

FUSE, FUSIBLE LINK AND RELAY BOX

PFP:24382

NKS000EO

FUSE, FUSIBLE LINK AND RELAY BOX

Terminal Arrangement

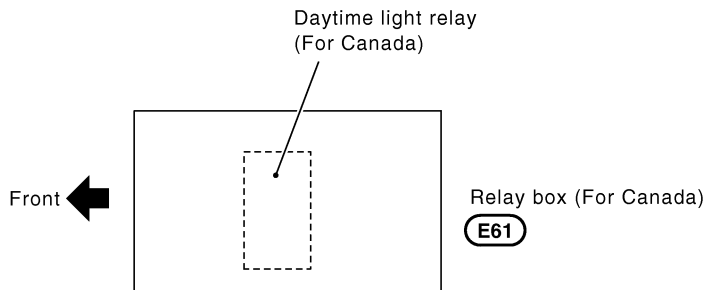
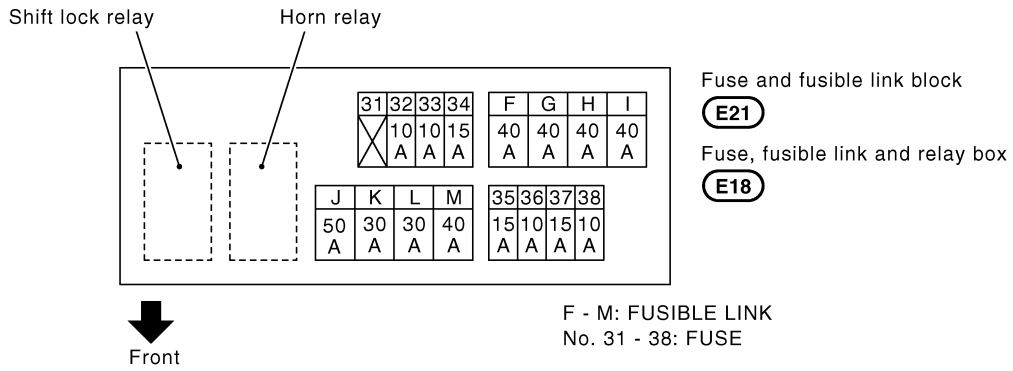
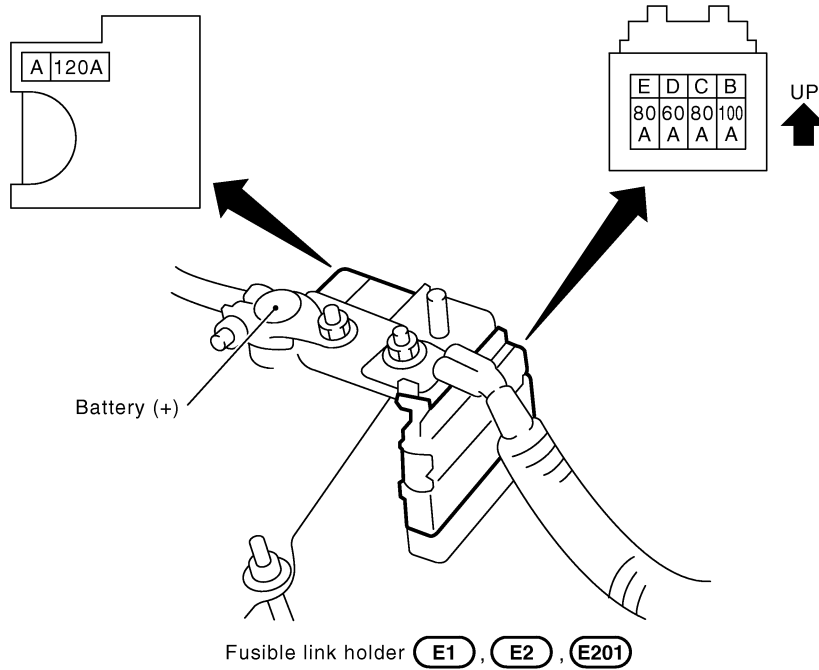

CKIT0744E