

GENERAL INFORMATION

SECTION **GI**

GI

MA

EM

LC

EF &
EC

CONTENTS

FE

CL

MT

AT

PD

FA

RA

BR

ST

BF

HA

EL

IDX

PRECAUTIONS	2	CONSULT CHECKING SYSTEM	15	
Precautions for Supplemental Restraint System "AIR BAG"	2	Function and System Application.....	15	
General Precautions	2	Checking Equipment.....	15	
Precautions for Multiport Fuel Injection System or ECCS Engine	4	IDENTIFICATION INFORMATION	16	
Precautions for Three Way Catalyst	4	Model Variation.....	16	
Precautions for Turbocharger	4	Identification Number.....	18	
Engine Oils.....	5	Dimensions.....	20	
Precautions for Fuel	6	Wheels and Tires	20	
HOW TO USE THIS MANUAL	7	LIFTING POINTS AND TOW TRUCK TOWING	21	
HOW TO READ WIRING DIAGRAMS	9	Garage Jack and Safety Stand.....	21	
HOW TO FOLLOW FLOW CHART IN TROUBLE		2-pole Lift.....	22	
DIAGNOSES	12	Tow Truck Towing.....	22	
		TIGHTENING TORQUE OF STANDARD BOLTS	24	
		SAE J1930 TERMINOLOGY LIST	25	

PRECAUTIONS

Observe the following precautions to ensure safe and proper servicing. These precautions are not described in each individual section.

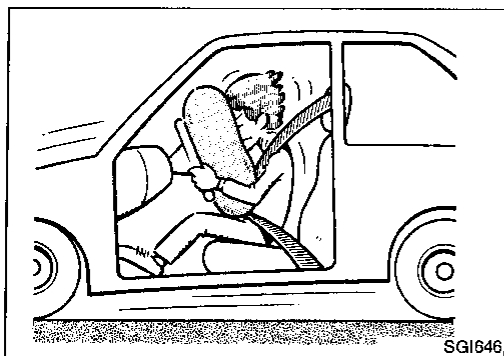

Precautions for Supplemental Restraint System "AIR BAG"

The Supplemental Restraint System "Air Bag" helps to reduce the risk or severity of injury to the driver and front passenger in a frontal collision. The Supplemental Restraint System consists of air bags (located in the center of the steering wheel and on the instrument panel on the passenger side), sensors, a diagnosis unit, warning lamp, wiring harness and spiral cable. Information necessary to service the system safely is included in the BF section of this Service Manual.

WARNING:

- To avoid rendering the SRS inoperative, which could lead to personal injury or death in the event of a severe frontal collision, all maintenance must be performed by an authorized NISSAN dealer.
- Improper maintenance, including incorrect removal and installation of the SRS, can lead to personal injury caused by unintentional activation of the system.
- All SRS electrical wiring harnesses and connectors are covered with yellow outer insulation. Do not use electrical test equipment on any circuit related to the SRS.

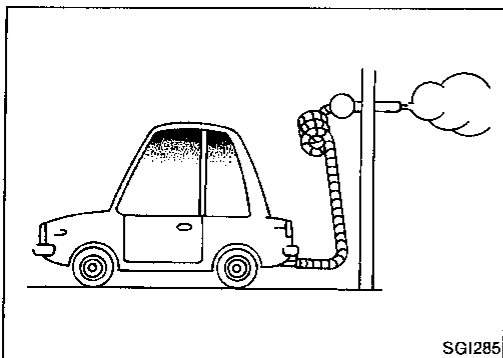

General Precautions

1. Do not operate the engine for an extended period of time without proper exhaust ventilation. Keep the work area well ventilated and free of any inflammable materials. Special care should be taken when handling any inflammable or poisonous materials, such as gasoline, refrigerant gas, etc. When working in a pit or other enclosed area, be sure to properly ventilate the area before working with hazardous materials. Do not smoke while working on the vehicle.
2. Before jacking up the vehicle, apply wheel chocks or other tire blocks to the wheels to prevent the vehicle from moving. After jacking up the vehicle, support the vehicle weight with safety stands at the points designated for proper lifting before working on the vehicle. These operations should be done on a level surface.
3. When removing a heavy component such as the engine or transaxle/transmission, be careful not to lose your balance and drop them. Also, do not allow them to strike adjacent parts, especially the brake tubes and master cylinder.

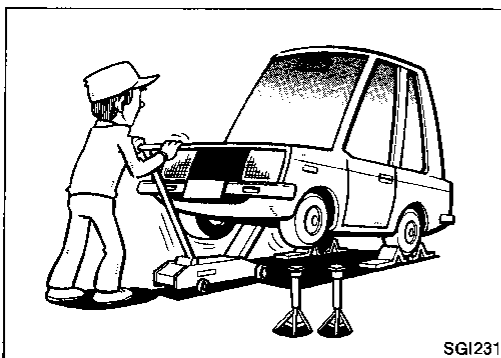

PRECAUTIONS

General Precautions (Cont'd)

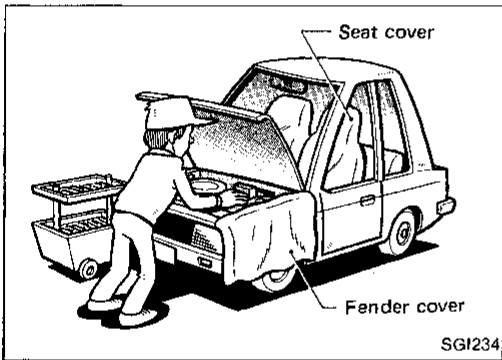
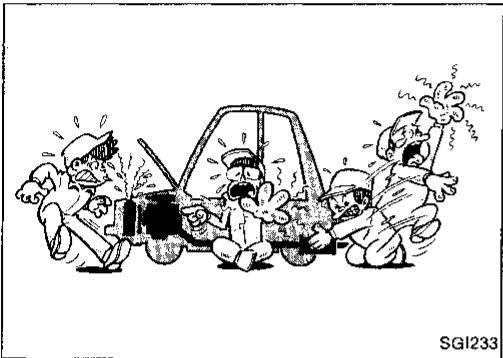
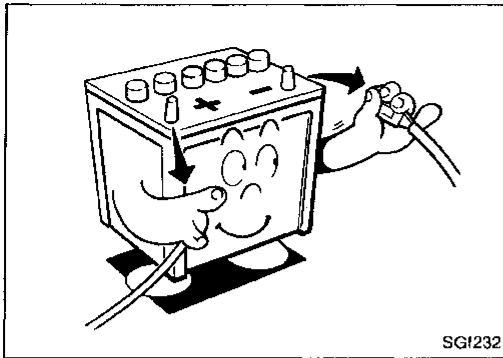

4. Before starting repairs which do not require battery power, always turn off the ignition switch, then disconnect the ground cable from the battery to prevent accidental short circuit.
5. To prevent serious burns, avoid contact with hot metal parts such as the radiator, exhaust manifold, tail pipe and muffler. Do not remove the radiator cap when the engine is hot.
6. Before servicing the vehicle, protect fenders, upholstery and carpeting with appropriate covers. Take caution that keys, buckles or buttons on your person do not scratch the paint.
7. Clean all disassembled parts in the designated liquid or solvent prior to inspection or assembly.
8. Replace oil seals, gaskets, packings, O-rings, locking washers, cotter pins, self-locking nuts, etc. with new ones.
9. Replace inner and outer races of tapered roller bearings and needle bearings as a set.
10. Arrange the disassembled parts in accordance with their assembled locations and sequence.
11. Do not touch the terminals of electrical components which use microcomputers (such as ECMs). Static electricity may damage internal electronic components.
12. After disconnecting vacuum or air hoses, attach a tag to indicate the proper connection.
13. Use only the fluids and the lubricants specified in MA section or their equivalents.
14. Use approved bonding agent, sealants or their equivalents when required.
15. Use tools and recommended special tools where specified for safe and efficient service repairs.
16. When repairing the fuel, oil, water, vacuum or exhaust systems, check all affected lines for leaks.
17. Dispose of drained oil or the solvent used for cleaning parts in an appropriate manner.

GI

MA

EM

LC

EF &
EC

FE

CL

MT

AT

PD

FA

RA

BR

ST

BF

HA

EL

IDX

PRECAUTIONS

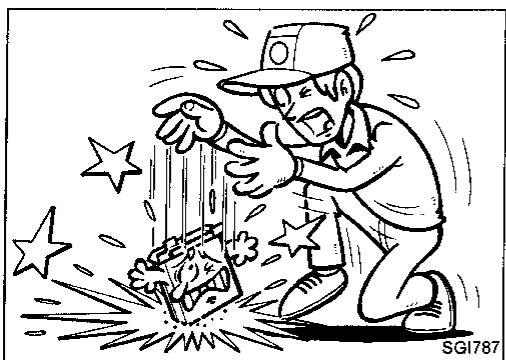

Precautions for Multiport Fuel Injection System or ECCS Engine

1. Before connecting or disconnecting multiport fuel injection system or ECCS harness connector to or from any multiport fuel injection system or ECM (ECCS control module), be sure to turn the ignition switch to the "OFF" position and disconnect the negative battery terminal. Otherwise, there may be damage to ECM.
2. Before disconnecting pressurized fuel line from fuel pump to injectors, be sure to release fuel pressure to eliminate danger.
3. Be careful not to jar components such as ECM and mass air flow sensor.

Precautions for Three Way Catalyst

If a large amount of unburned fuel flows into the converter, the converter temperature will be excessively high. To prevent this, follow the procedure below:

1. Use unleaded gasoline only. Leaded gasoline will seriously damage the three way catalyst.
2. When checking for ignition spark or measuring engine compression, make tests quickly and only when necessary.
3. Do not run engine when the fuel tank level is low, otherwise the engine may misfire causing damage to the converter.
4. Do not place the vehicle on flammable material. Keep flammable material off the exhaust pipe.

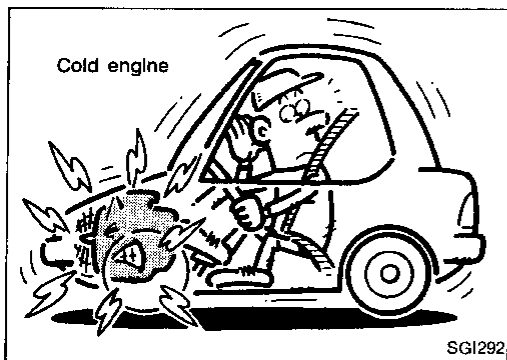

Precautions for Turbocharger

The turbocharger turbine revolves at extremely high speeds and becomes very hot. Therefore, it is essential to maintain a clean supply of oil flowing through the turbocharger and to follow all required maintenance instructions and operating procedures.

For proper operation of the system, follow the procedure below.

1. Always use the recommended oil. Follow the instructions for proper time to change the oil and proper oil level.
2. Avoid accelerating engine to a high rpm immediately after starting.
3. If engine had been operating at high rpm for an extended period of time, let it idle for a few minutes prior to shutting it off.

PRECAUTIONS

Engine Oils

Prolonged and repeated contact with used engine oil may cause skin cancer. Try to avoid direct skin contact with used oil. If skin contact is made, wash thoroughly with soap or hand cleaner as soon as possible.

GI

HEALTH PROTECTION PRECAUTIONS

1. Avoid prolonged and repeated contact with oils, particularly used engine oils. MA
2. Wear protective clothing, including impervious gloves where practicable. EM
3. Do not put oily rags in pockets.
4. Avoid contaminating clothes, particularly underpants, with oil. LC
5. Heavily soiled clothing and oil-impregnated footwear should not be worn. Overalls must be cleaned regularly. EF & EC
6. First Aid treatment should be obtained immediately for open cuts and wounds.
7. Use barrier creams, applying them before each work period, to help the removal of oil from the skin. FE
8. Wash with soap and water to ensure all oil is removed (skin cleansers and nail brushes will help). Preparations containing lanolin replace the natural skin oils which have been removed. CL
9. Do not use gasoline, kerosine, diesel fuel, gas oil, thinners or solvents for cleaning skin. MT
10. If skin disorders develop, obtain medical advice without delay. AT
11. Where practicable, degrease components prior to handling.
12. Where there is a risk of eye contact, eye protection should be worn, for example, chemical goggles or face shields; in addition an eye wash facility should be provided. PD

ENVIRONMENTAL PROTECTION PRECAUTIONS

Burning used engine oil in small space heaters or boilers can be recommended only for units of approved design. The heating system must meet the requirements of HM Inspectorate of Pollution for small burners of less than 0.4 MW. If in doubt check with the appropriate local authority and/or manufacturer of the approved appliance. FA

Dispose of used oil and used oil filters through authorized waste disposal contractors to licensed waste disposal sites, or to the waste oil reclamation trade. If in doubt, contact the local authority for advice on disposal facilities. RA

It is illegal to pour used oil on to the ground, down sewers or drains, or into water courses. BR

The regulations concerning the pollution of the environment will vary from country to country. ST

BF

HA

EL

IDX

PRECAUTIONS

Precautions for Fuel

To maintain engine and exhaust system durability and performance, UNLEADED PREMIUM gasoline with an octane rating of at least 91 AKI (Research octane number 96) must be used.

If premium unleaded gasoline is not available, REGULAR UNLEADED gasoline with an octane rating of 87 AKI (Research octane number 91) may be used temporarily, but only under the following conditions:

- The fuel tank should be filled only partially with unleaded regular gasoline, and filled up with premium unleaded gasoline as soon as possible.
- Full throttle driving and abrupt acceleration should be avoided.

Use UNLEADED fuel only. Under no circumstances should leaded gasoline be used. Lead gasoline will damage the three way catalyst and increase dangerous emissions from the vehicle exhaust.

HOW TO USE THIS MANUAL



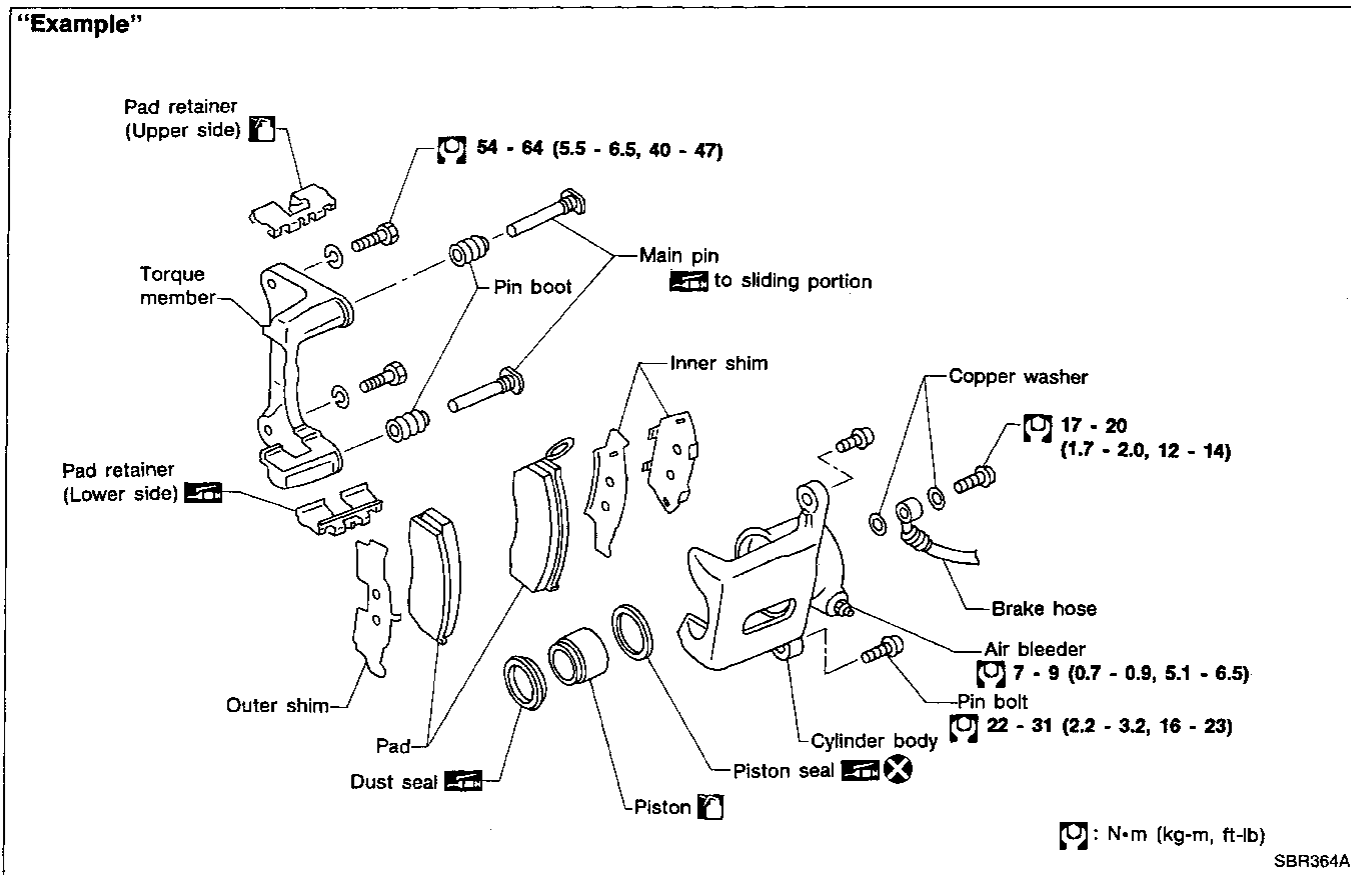







1. **ALPHABETICAL INDEX** is provided at the end of this manual so that you can rapidly find the item and page you are searching for.
2. **A QUICK REFERENCE INDEX**, a black tab (e.g. **BR**) is provided on the first page. You can quickly find the first page of each section by mating it to the section's black tab.
3. **THE CONTENTS** are listed on the first page of each section.
4. **THE TITLE** is indicated on the upper portion of each page and shows the part or system.
5. **THE PAGE NUMBER** of each section consists of two letters which designate the particular section and a number (e.g. "BR-5").
6. **THE LARGE ILLUSTRATIONS** are exploded views (See below.) and contain tightening torques, lubrication points and other information necessary to perform repairs. The illustrations should be used in reference to service matters only. When ordering parts, refer to the appropriate **PARTS CATALOG**.



7. **THE SMALL ILLUSTRATIONS** show the important steps such as inspection, use of special tools, knacks of work and hidden or tricky steps which are not shown in the previous large illustrations. Assembly, inspection and adjustment procedures for complicated units such as the automatic trans-axle or transmission, etc. are presented in a step-by-step format where necessary.

HOW TO USE THIS MANUAL

8. The following **SYMBOLS AND ABBREVIATIONS** are used:

	: Tightening torque	Tool	: Special Service Tools
	: Should be lubricated with grease. Unless otherwise indicated, use recommended multi-purpose grease.	ATF	: Automatic Transmission Fluid
	: Should be lubricated with oil.	D ₁	: Drive range 1st gear
	: Sealing point	D ₂	: Drive range 2nd gear
	: Checking point	D ₃	: Drive range 3rd gear
	: Always replace after every disassembly.	D ₄	: Drive range 4th gear
	: Apply petroleum jelly.	OD	: Overdrive
	: Apply ATF.	2 ₂	: 2nd range 2nd gear
	: Select with proper thickness.	2 ₁	: 2nd range 1st gear
	: Adjustment is required.	1 ₂	: 1st range 2nd gear
SDS	: Service Data and Specifications	1 ₁	: 1st range 1st gear
LH, RH	: Left-Hand, Right-Hand	FR, RR	: Front, Rear
M/T	: Manual Transaxle/Transmission	2WD	: 2-Wheel Drive
A/T	: Automatic Transaxle/Transmission	A/C	: Air Conditioner
		P/S	: Power Steering
		SAE	: Society of Automotive Engineers, Inc.

9. The **UNITS** given in this manual are primarily expressed as SI UNITS (International System of Unit), and alternately expressed in the metric system and in the yard/pound system.

“Example”

Tightening torque:

59 - 78 N·m (6.0 - 8.0 kg-m, 43 - 58 ft-lb)

10. **TROUBLE DIAGNOSES** are included in sections dealing with complicated components.

11. **SERVICE DATA AND SPECIFICATIONS** are contained at the end of each section for quick reference of data.

12. The captions **WARNING** and **CAUTION** warn you of steps that must be followed to prevent personal injury and/or damage to some part of the vehicle.

- **WARNING** indicates the possibility of personal injury if instructions are not followed.
- **CAUTION** indicates the possibility of component damage if instructions are not followed.
- **BOLD TYPED STATEMENTS** except **WARNING** and **CAUTION** give you helpful information.

HOW TO READ WIRING DIAGRAMS

WIRING DIAGRAM

Symbols used in WIRING DIAGRAM are shown below:

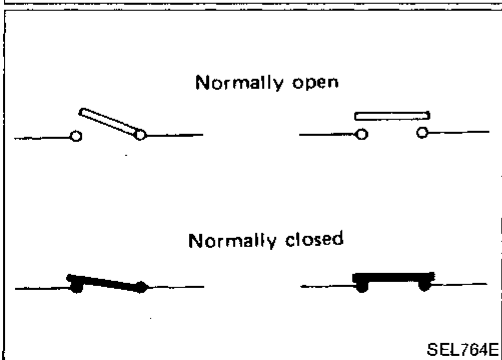
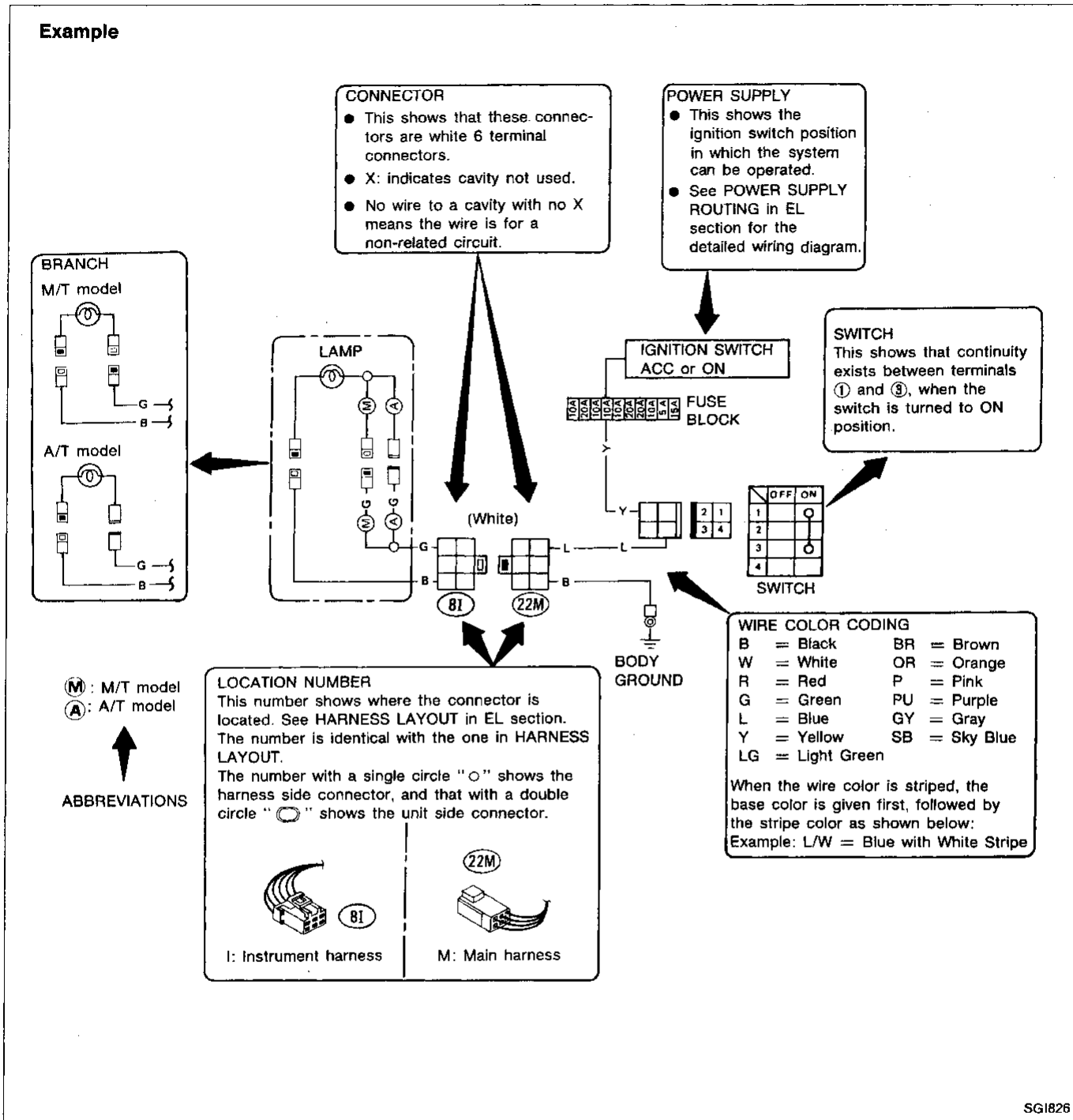

GI
MA
EM
LC
EF & EC
FE
CL
MT
AT
PD
FA
RA
BR
ST
BF
HA
EL
IDX

HOW TO READ WIRING DIAGRAMS

Example

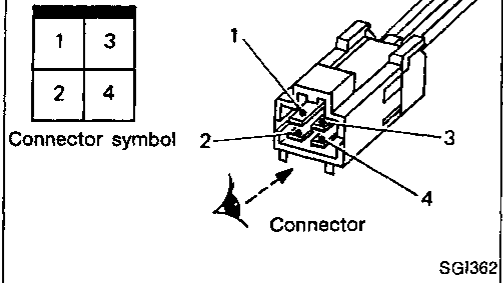

CONNECTOR SYMBOLS

- All connector symbols in wiring diagrams are shown from the terminal side.

Example

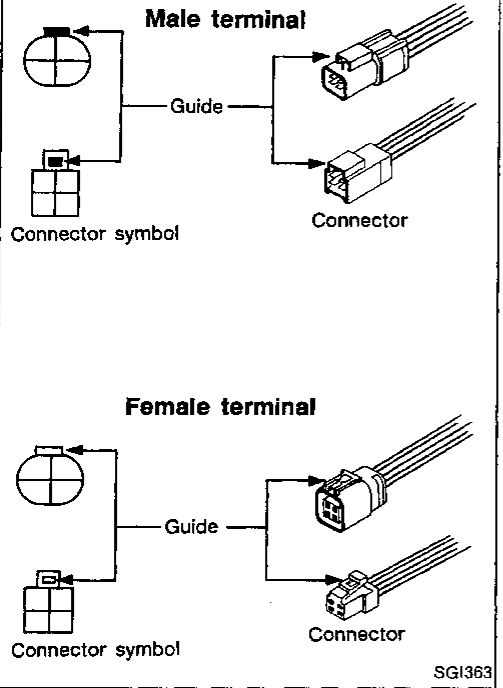

- Male and female terminals
Connector guides for male terminals are shown in black and female terminals in white in wiring diagrams.

MULTIPLE SWITCH

The continuity of the multiple switch is identified in the switch chart in wiring diagrams.

Example

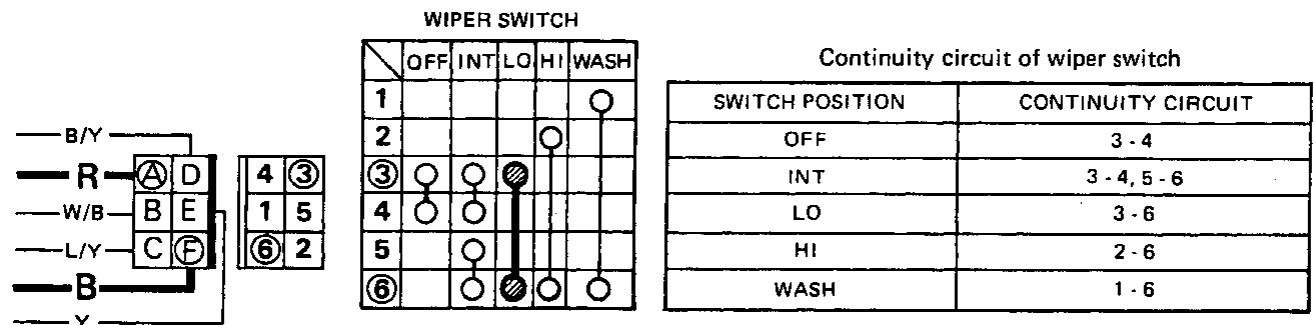

Example: Wiper switch in LO position

Continuity circuit: Red wire - (A) terminal - (③) terminal - Wiper switch (● - ● : LO) - (⑥) terminal - (F) terminal - Black wire

SGI365

HOW TO READ WIRING DIAGRAMS

SUPER MULTIPLE JUNCTION (SMJ)

- The "SMJ" indicated in wiring diagrams is shown in a simplified form. The terminal arrangement should therefore be referred to in the foldout at the end of the Service Manual.
- The foldout should be spread to read the entire wiring diagram.

GI

Example

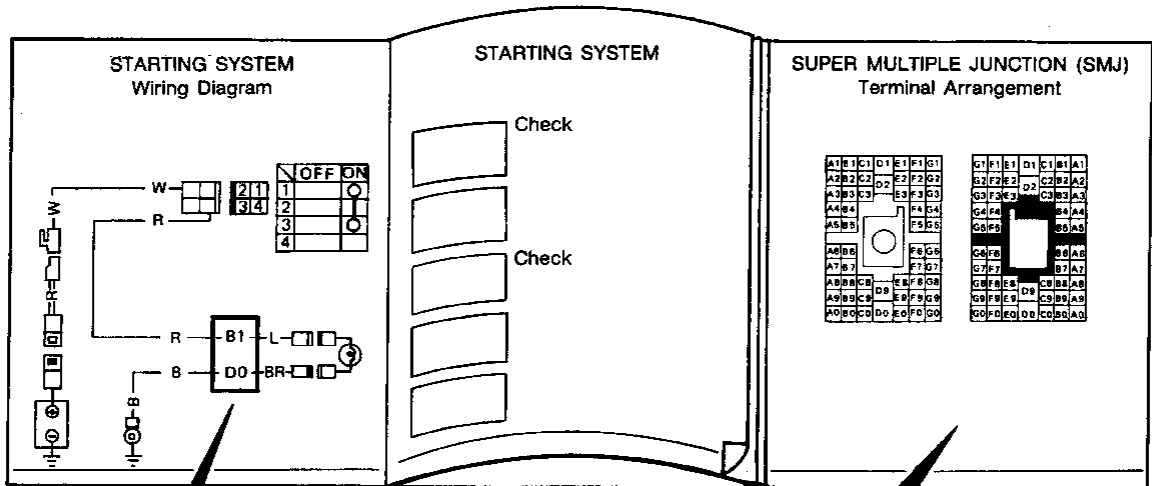

MA

EM

LC

EF & EC

FE

CL

MT

AT

PD

FA

RA

BR

ST

BF

HA

EL

IDX

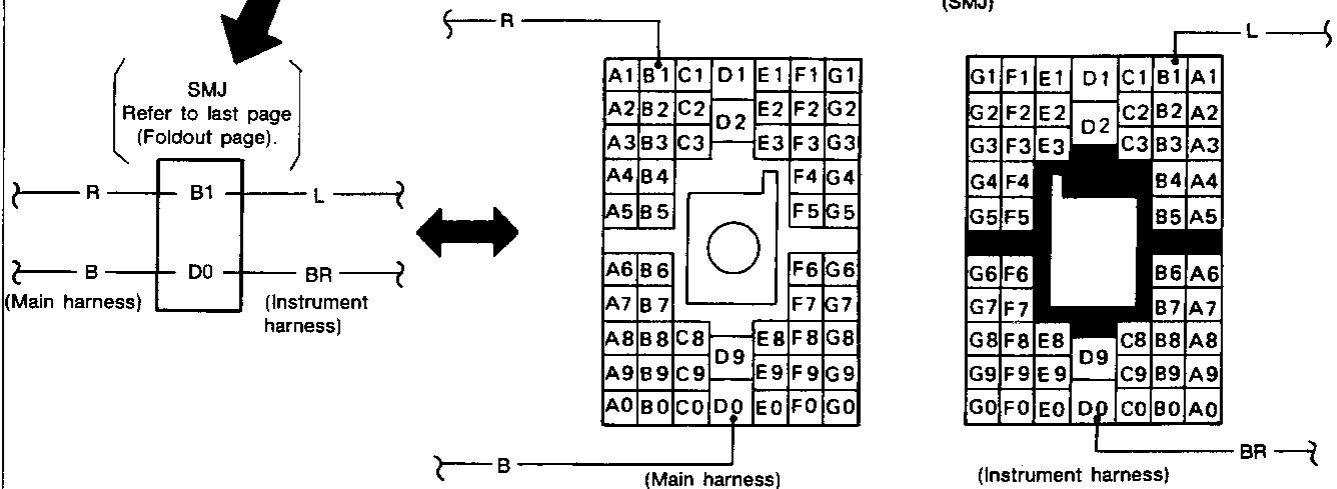

SGI818

HOW TO FOLLOW FLOW CHART IN TROUBLE DIAGNOSES

Example

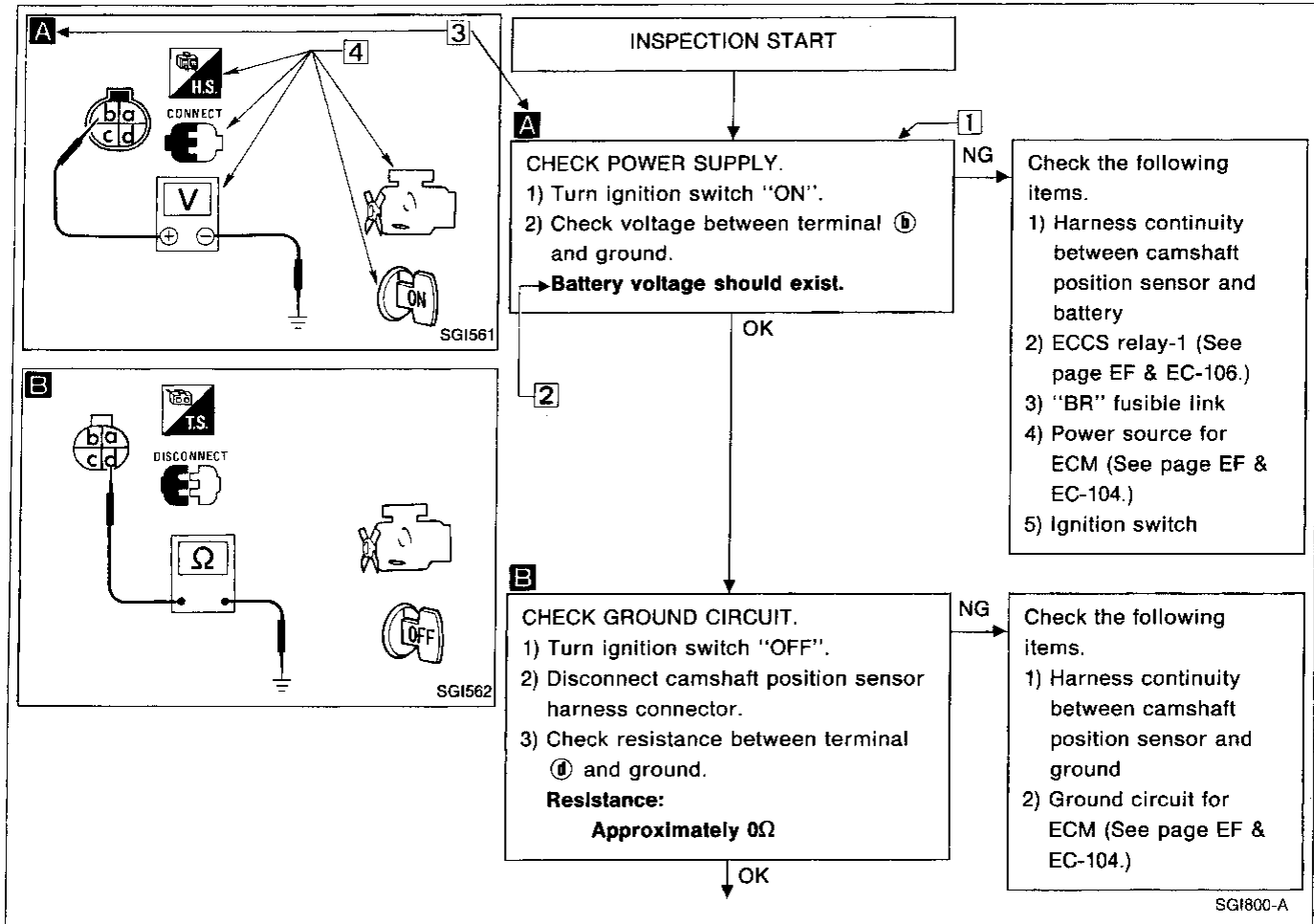

NOTICE

The flow chart indicates work procedures required to diagnose problems effectively. Observe the following instructions before diagnosing.

- 1) Use the flow chart after locating probable causes of a problem following the "Preliminary Check" or the "Symptom Chart".
- 2) After repairs, re-check that the problem has been completely eliminated.
- 3) Refer to Component Parts Location and Harness Layout for the Systems described in each section for identification/location of components and harness connectors.
- 4) Refer to the Circuit Diagram for Quick Pinpoint Check. If you must check circuit continuity between harness connectors in more detail, such as when a sub-harness is used, refer to Wiring Diagram and Harness Layout in EL section for identification of harness connectors.
- 5) When checking circuit continuity, ignition switch should be "OFF".
- 6) Before checking voltage at connectors, check battery voltage.
- 7) After accomplishing the Diagnostic Procedures and Electrical Components Inspection, make sure that all harness connectors are reconnected as they were.

HOW TO FOLLOW THIS FLOW CHART

1 Work and diagnostic procedure

Start to diagnose a problem using procedures indicated in enclosed blocks, as shown in the following example.

A

CHECK POWER SUPPLY.
 1) Turn ignition switch "ON".
 2) Check voltage between terminal **(B)** and ground.
Battery voltage should exist.

← Check item being performed.
 } Procedure, steps or measurement results

2 Measurement results

Required results are indicated in bold type in the corresponding block, as shown below:

These have the following meanings:

Battery voltage → 11 - 14V or approximately 12V

Voltage: Approximately 0V → Less than 1V

3 Cross reference of work symbols in the text and illustrations

Illustrations are provided as visual aids for work procedures. For example, symbol **A** indicated in the left upper portion of each illustration corresponds with the symbol in the flowchart for easy identification. More precisely, the procedure under the "CHECK POWER SUPPLY" outlined previously is indicated by an illustration **A**.

4 Symbols used in illustrations

Symbols included in illustrations refer to measurements or procedures. Before diagnosing a problem, familiarize yourself with each symbol.

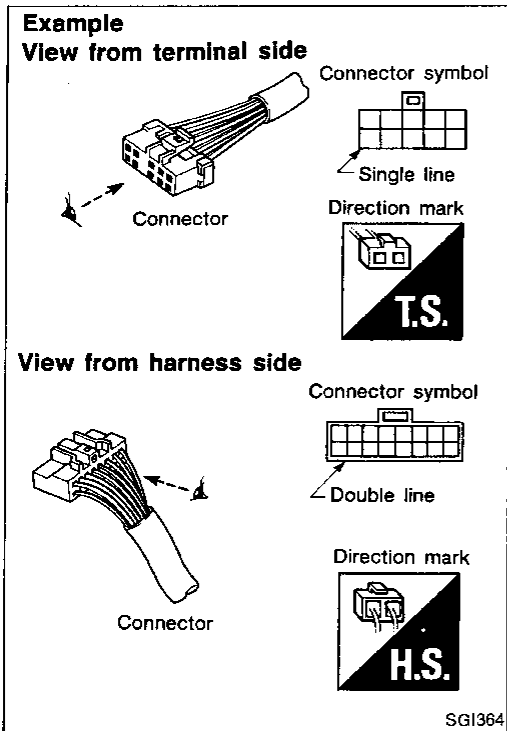

Direction mark

A direction mark is shown to clarify the side of connector (terminal side or harness side).

Direction marks are mainly used in the illustrations indicating terminal inspection.



: View from terminal side ... TS

- All connector symbols shown from the terminal side are enclosed by a single line.























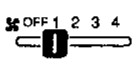

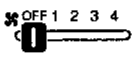

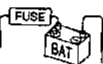









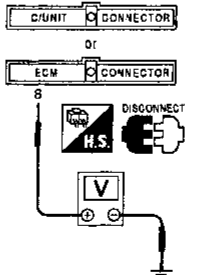
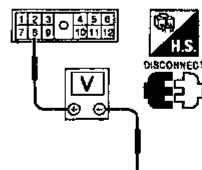

: View from harness side ... HS

- All connector symbols shown from the harness side are enclosed by a double line.

HOW TO FOLLOW FLOW CHART IN TROUBLE DIAGNOSES

Key to symbols signifying measurements or procedures

Symbol	Symbol explanation	Symbol	Symbol explanation
	Check after disconnecting the connector to be measured.		Procedure without CONSULT
	Check after connecting the connector to be measured.		A/C switch is "OFF".
	Insert key into ignition switch.		A/C switch is "ON".
	Turn ignition switch to "OFF" position.		REC switch is "ON".
	Turn ignition switch to "ON" position.		REC switch is "OFF".
	Turn ignition switch to "START" position.		DEF switch is "ON".
	Turn ignition switch from "OFF" to "ACC" position.		Fan switch is "ON". (At any position except for "OFF" position)
	Turn ignition switch from "ACC" to "OFF" position.		Fan switch is "OFF".
	Turn ignition switch from "OFF" to "ON" position.		Apply fused battery positive voltage directly to components.
	Turn ignition switch from "ON" to "OFF" position.		Drive vehicle.
	Do not start engine, or check with engine stopped.		Disconnect battery negative cable.
	Start engine, or check with engine running.		Depress brake pedal.
	Apply parking brake.		Release brake pedal.
	Release parking brake.		Depress accelerator pedal.
	Release parking brake.		Release accelerator pedal.
	Check after engine is warmed up sufficiently.		Pin terminal check for SMJ type ECM and A/T control unit connectors. For details regarding the terminal arrangement, refer to the foldout page. 
	Voltage should be measured with a voltmeter.		
	Circuit resistance should be measured with an ohmmeter.		
			
	Current should be measured with an ammeter.		
	Procedure with CONSULT		

CONSULT CHECKING SYSTEM

Function and System Application

Diagnostic test mode	Function	ECCS	Auto A/C	A/T	HICAS	Air bag	ASCD
Work support	This mode enables a technician to adjust some devices faster and more accurately by following the indications on CONSULT.	X	X	—	—	—	—
Self-diagnostic results	Self-diagnostic results can be read and erased quickly.	X	X	X	X	X	X
Data monitor	Input/Output data in the ECM can be read.	X	X	X	X	—	X
Active test	Diagnostic Test Mode in which CONSULT drives some actuators apart from the ECMs and also shifts some parameters in a specified range.	X	X	—	X	—	—
ECM part number	ECM part number can be read.	X	—	X	X	—	—
Function test	ECCS faults can be isolated to a general area, semi-automatically and in a short time, by following the directions on the screen.	X	—	—	—	—	—

X: Applicable

Checking Equipment

When ordering the below equipment, contact your NISSAN distributor.

Tool name	Description
NISSAN CONSULT kit ① CONSULT unit and accessories. ② Program card (UE 930)* ③ Operation manuals ④ Binder ⑤ Carrying case ⑥ Thermal paper (Rolls)	<p style="text-align: left; margin-top: 10px;">NT003</p>

*: Regarding HICAS system of 1994 model year, the new program card (UE 940) will be applicable.

IDENTIFICATION INFORMATION

Model Variation

Destination		Body	Model		Engine	Transmission	Differential carrier		
U.S.A.	Non-California	Standard roof	2 seater	RL-JU	VG30DE	RS5R30A	R200V		
		T-bar roof		KRL-XU		RS5R30A			
				KRL-XAU		RE4R01A			
		2+2		KRL-XSU	VG30DETT	RS5R30A	R230V		
			KRL-XASU	RE4R03A					
		Convertible	2 seater	KRLG-XU	VG30DE	RS5R30A	R200V		
	KRLG-XAU			RE4R01A					
	California	Standard roof	2 seater	RL-JV	VG30DE	RS5R30A	R200V		
		T-bar roof		KRL-XV		RS5R30A			
				KRL-XAV		RE4R01A			
		2+2		KRL-XSV	VG30DETT	RS5R30A	R230V		
			KRL-XASV	RE4R03A					
		Convertible	2 seater	KRLG-XV	VG30DE	RS5R30A	R200V		
				KRLG-XAV		RE4R01A			
		Canada	T-bar roof	2 seater	KRL-JV	VG30DE	RS5R30A	R200V	
					CRL-JAV		RE4R01A		
					2+2	KRL-XN	VG30DE	RS5R30A	R200V
						KRL-XAN		RE4R01A	
Convertible			2 seater	KRL-XSN	VG30DETT	RS5R30A	R230V		
	KRL-XASN			RE4R03A					
T-bar roof	2+2	KRLG-XN	VG30DE	RS5R30A	R200V				
		KRLG-XAN		RE4R01A					
Convertible	2 seater	CRL-JN	VG30DE	RS5R30A	R200V				

IDENTIFICATION INFORMATION

Model Variation (Cont'd)

Prefix and suffix designations:

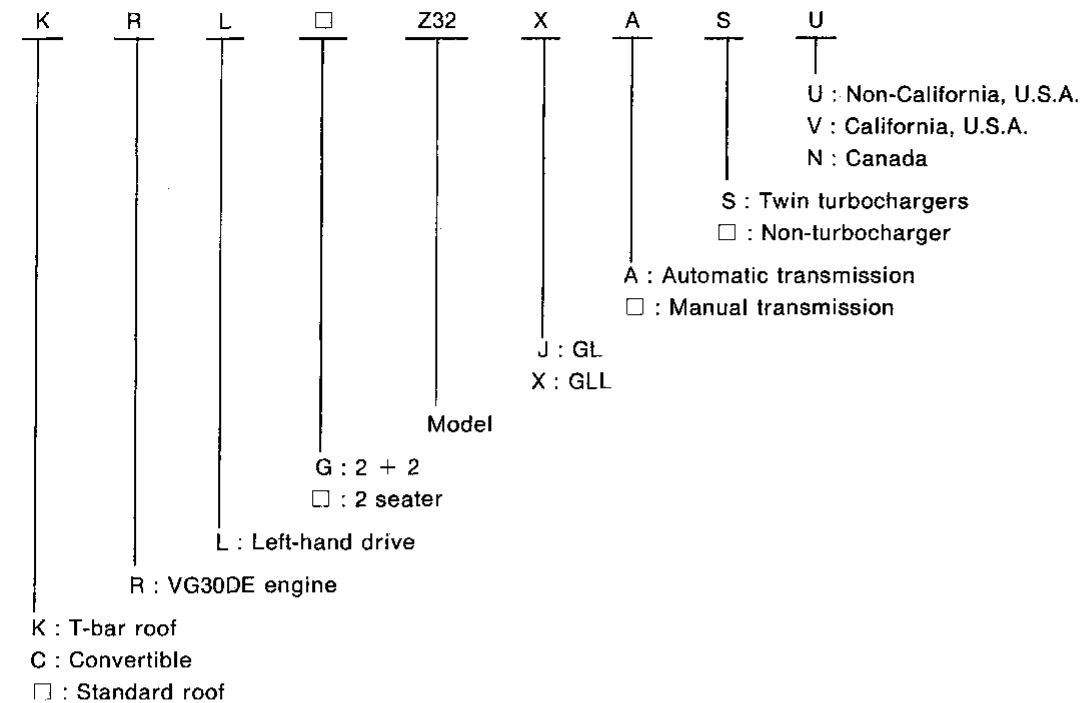

Note: □ means no indication.

GI

MA

EM

LC

EF &
EC

FE

CL

MT

AT

PD

FA

RA

BR

ST

BF

HA

EL

IDX

IDENTIFICATION INFORMATION

Identification Number

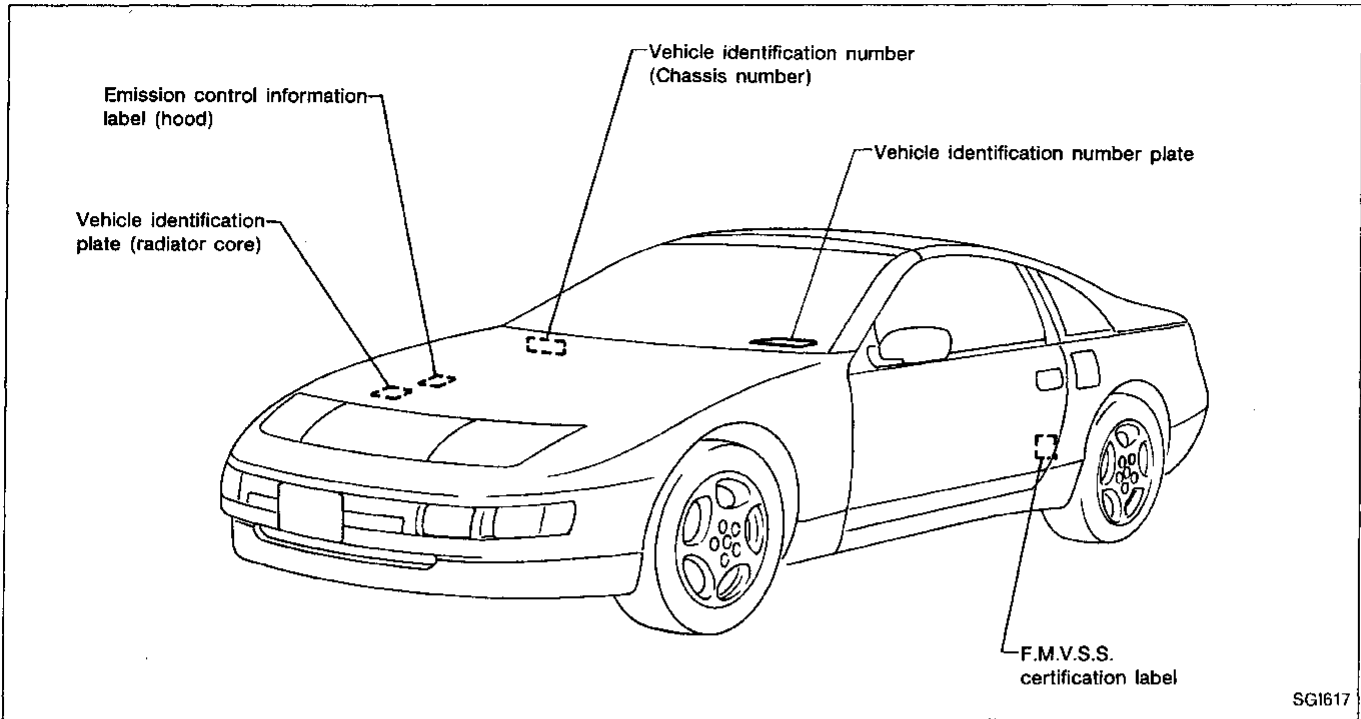

SGI617

VEHICLE IDENTIFICATION NUMBER ARRANGEMENT

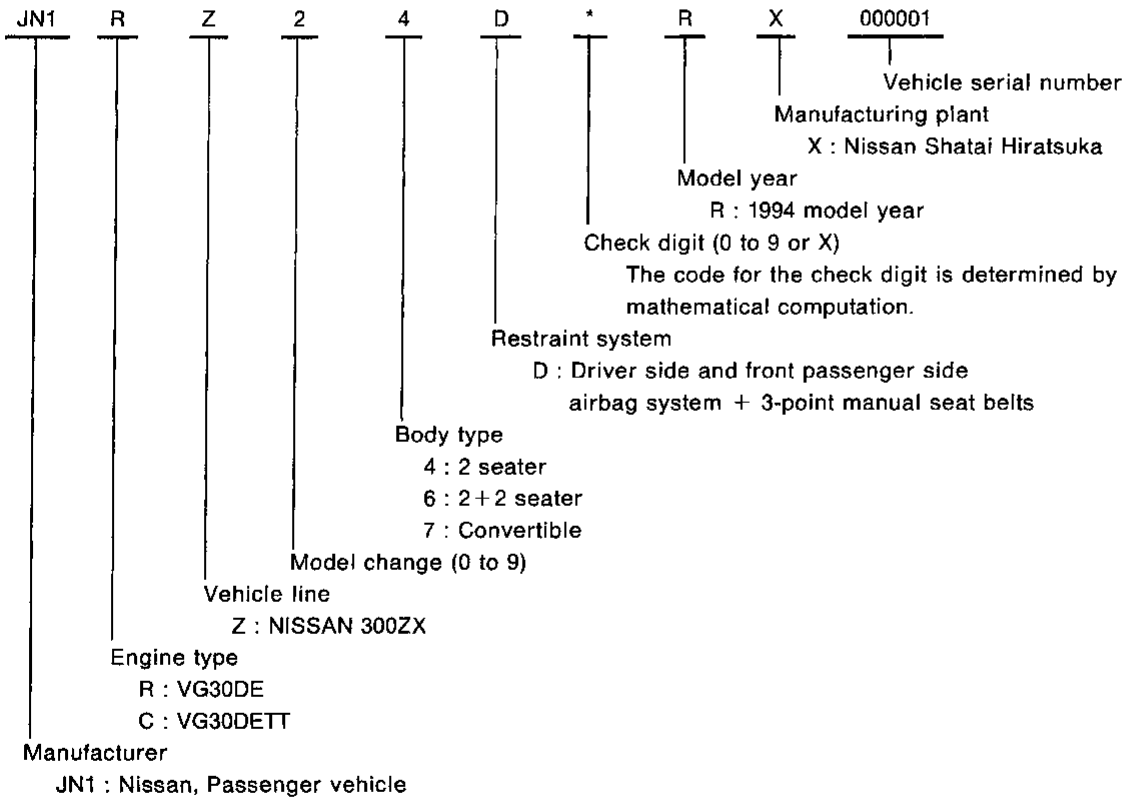

IDENTIFICATION INFORMATION

Identification Number (Cont'd)

IDENTIFICATION PLATE

NISSAN MOTOR CO., LTD. JAPAN			
型式	TYPE	△	
	TIPO		
CHASSIS NO.		△	
NO. DE CHASSIS			
MODEL		△	
MODELO			
○ カラー-COLOR TRIM		△ △	○
トリム-COLOR GUARNICION			
エン ENGINE		△ △	CC
ジン MOTOR			
ミッション TRANS. AXLE		△ △	
アクスル TRANS. EJE			
	工場		PLANT
			PLANTA
日産自動車株式会社		MADE IN JAPAN	

- 1 Type
- 2 Vehicle identification number (Chassis number)
- 3 Model
- 4 Body color code
- 5 Trim color code
- 6 Engine model
- 7 Engine displacement
- 8 Transmission model
- 9 Axle model

SGI315

ENGINE SERIAL NUMBER

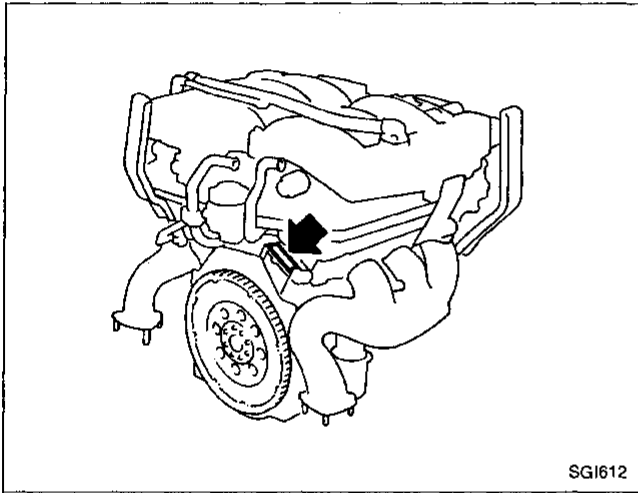

AUTOMATIC TRANSMISSION NUMBER

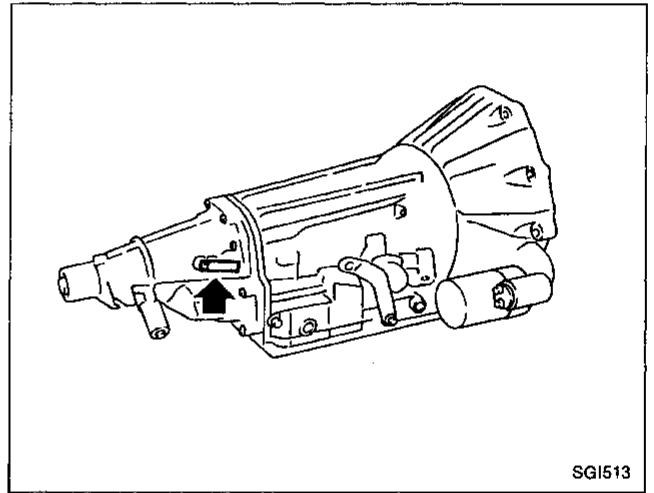

MANUAL TRANSMISSION NUMBER

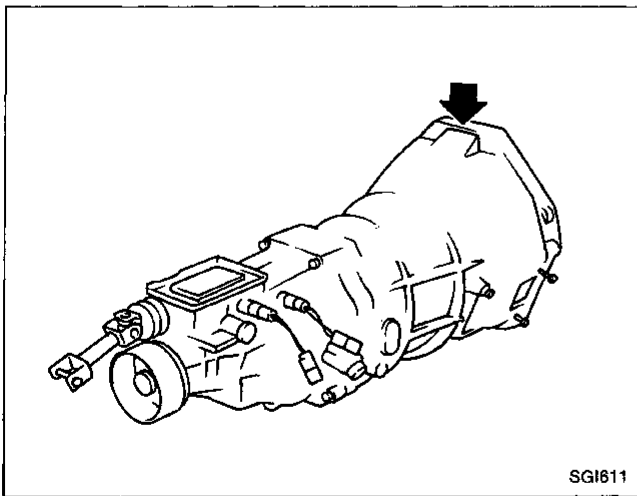

GI
MA
EM
LC
EF &
EC
FE
CL
MT
AT
PD
FA
RA
BR
ST
BF
HA
EL
IDX

IDENTIFICATION INFORMATION

Dimensions

Unit: mm (in)

Model		2 seater	2+2 seater	Convertible
Overall length	mm (in)	4,310 (169.7)	4,525 (178.1)	4,310 (169.7)
Overall width	mm (in)	1,790 (70.5)	1,800 (70.9)	1,790 (70.5)
Overall height	mm (in)			
T-bar		1,250 (49.2)	1,255 (49.4)	1,255 (49.4)
Standard		1,245 (49.0)	—	
Wheelbase	mm (in)	2,450 (96.5)	2,570 (101.2)	2,450 (96.5)
Tread	mm (in)			
Front		1,495 (58.9)	1,495 (58.9)	1,495 (58.9)
Rear		1,535 (60.4)*1 1,555 (61.2)*2	1,535 (60.4)	1,535 (60.4)

*1: VG30DE engine model

*2: VG30DETT engine model

Wheels and Tires

Road wheel	Aluminum	Steel	Offset mm (in)
Conventional	16 x 7.5JJ 16 x 8.5JJ*1	—	45 (1.77) 35 (1.38)*1
Spare			
T-type*4	—	16 x 4T	30 (1.18)
Space-saver tire*5	15 x 5J*6	15 x 5J*7	30 (1.18)
Tire size			
Conventional		P225/50R16 91V P225/50R16 92V P225/50ZR16*2 P245/45ZR16*3	
Spare			
T-type*4		T125/90D16	
Space-saver tire*5		165/80D15FS	

*1: Rear wheel for VG30DETT engine model

*2: Front tire for VG30DETT engine model

*3: Rear tire for VG30DETT engine model

*4: 2+2 seater model

*5: 2 seater model

*6: VG30DETT engine model

*7: VG30DE engine model

Garage Jack and Safety Stand

WARNING:

- Never get under the vehicle while it is supported only by the jack. Always use safety stands to support the frame when you have to get under the vehicle.
- Place wheel chocks at both front and back of the wheels on the ground.

CAUTION:

Place a wooden or rubber block between safety stand and vehicle body when the supporting body is flat.

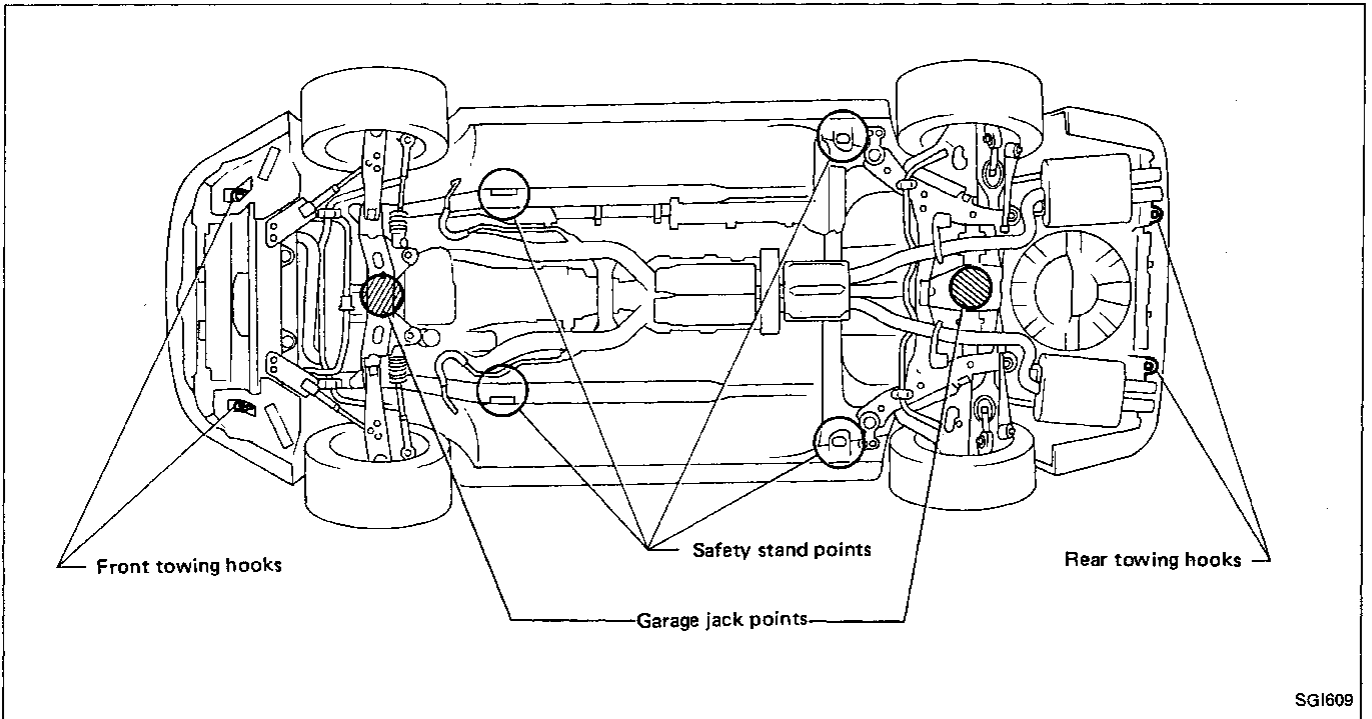

GI

MA

EM

LC

EF &
EC

FE

CL

MT

AT

PD

FA

RA

BR

ST

BF

HA

EL

IDX

LIFTING POINTS AND TOW TRUCK TOWING

2-pole Lift

WARNING:

When lifting the vehicle, open the lift arms as wide as possible and ensure that the front and rear of the vehicle are well balanced.

When setting the lift arm, do not allow the arm to contact the brake tubes and fuel lines.

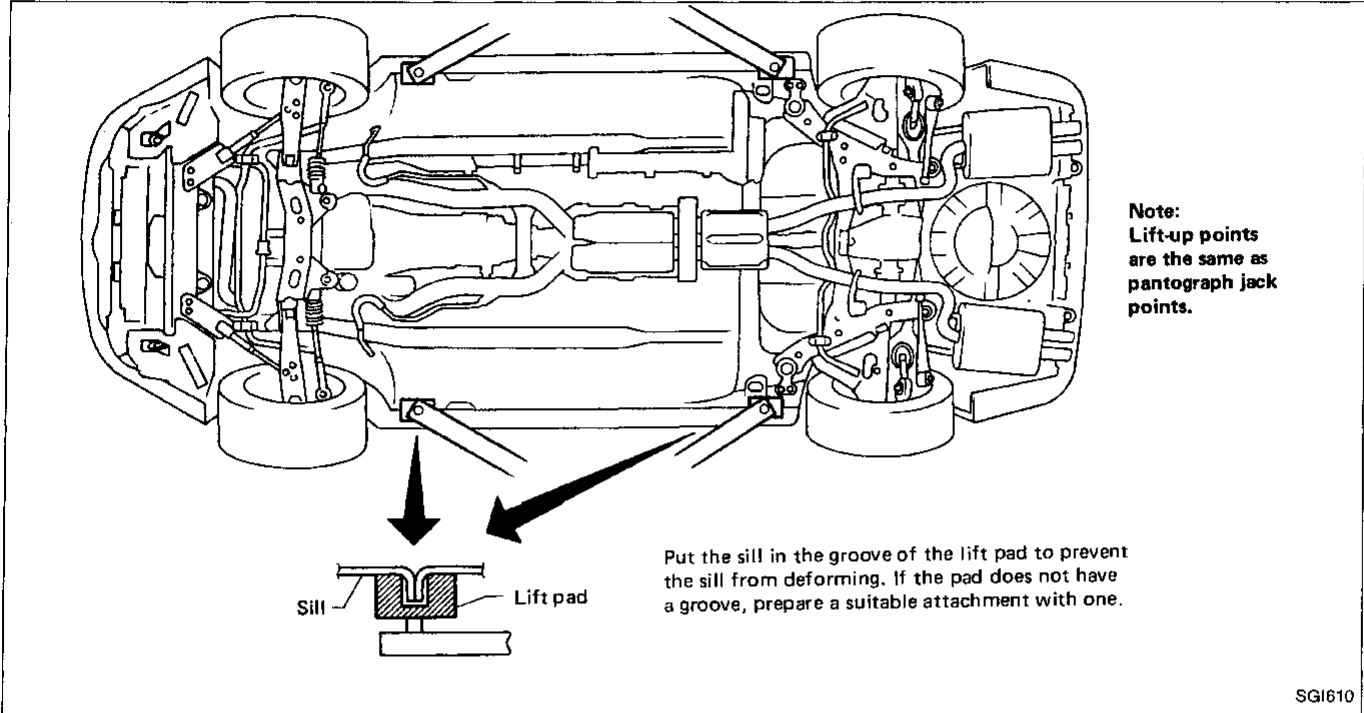

Tow Truck Towing

CAUTION:

- All applicable state or Provincial (in Canada) laws and local laws regarding the towing operation must be obeyed.
- It is necessary to use proper towing equipment to avoid possible damage to the vehicle during towing operation. Towing is in accordance with Towing Procedure Manual at dealer.
- When towing with the rear wheels on the ground, release the parking brake and move the gearshift lever to neutral position ("N" position).

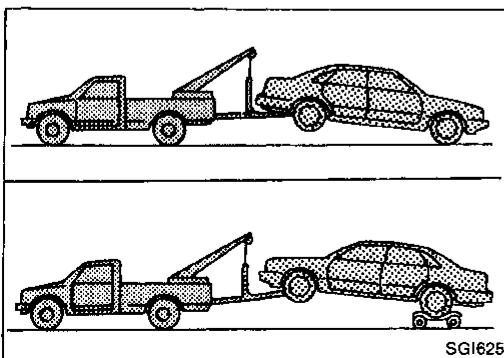

NISSAN recommends that vehicle be towed with the driving (rear) wheels off the ground as illustrated.

LIFTING POINTS AND TOW TRUCK TOWING

Tow Truck Towing (Cont'd)

TOWING AN AUTOMATIC TRANSMISSION MODEL WITH FOUR WHEELS ON GROUND OR TOWING WITH FRONT WHEELS RAISED (With rear wheels on ground)

Observe the following restricted towing speeds and distances.

Speed:

Below 50 km/h (30 MPH)

Distance:

Less than 65 km (40 miles)

If the speed or distance must necessarily be greater, remove the propeller shaft beforehand to prevent damage to the transmission.

GI

MA

EM

LC

EF &
EC

FE

CL

MT

AT

PD

FA

RA

BR

ST

BF

HA

EL

IDX

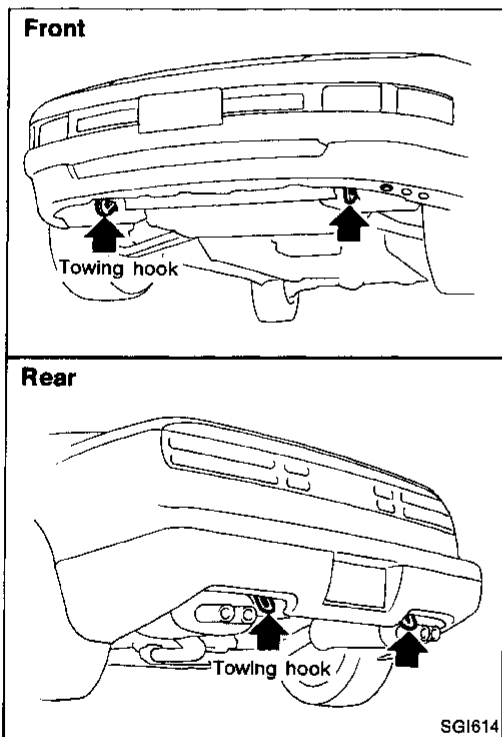

TOWING POINT

- Always pull the cable straight out from the vehicle. Never pull on the hook at a sideways angle.
- Remove the first bolt under the front fender protector when using the front towing hooks.

SAE J1930 TERMINOLOGY LIST

All emission related terms used in this publication are listed in accordance with SAE J1930. Accordingly, new terms, new acronyms/abbreviations and old terms are listed in the following chart.

***: Not applicable

NEW TERM	NEW ACRONYM / ABBREVIATION	OLD TERM	
Air cleaner	ACL	Air cleaner	GI
Barometric pressure	BARO	***	MA
Barometric pressure sensor-BCDD	BAROS-BCDD	BCDD	
Camshaft position	CMP	***	EM
Camshaft position sensor	CMPS	Crank angle sensor	
Carburetor	CARB	Carburetor	LC
Charge air cooler	CAC	Intercooler	
Closed loop	CL	Closed loop	EF & EC
Closed throttle position switch	CTP switch	Idle switch	
Clutch pedal position switch	CPP switch	Clutch switch	FE
Continuous fuel injection system	CFI system	***	
Continuous trap oxidizer system	CTOX system	***	CL
Crankshaft position	CKP	***	
Crankshaft position sensor	CKPS	***	MT
Data link connector	DLC	***	
Data link connector for CONSULT	DLC for CONSULT	Diagnostic connector for CONSULT	AT
Diagnostic test mode	DTM	Diagnostic mode	
Diagnostic test mode selector	DTM selector	Diagnostic mode selector	PD
Diagnostic test mode I	DTM I	Mode I	
Diagnostic test mode II	DTM II	Mode II	FA
Diagnostic trouble code	DTC	Malfunction code	
Direct fuel injection system	DFI system	***	RA
Distributor ignition system	DI system	Ignition timing control	
Early fuel evaporation-mixture heater	EFE-mixture heater	Mixture heater	BR
Early fuel evaporation system	EFE system	Mixture heater control	
Electrically erasable programmable read only memory	EEPROM	***	ST
Electronic ignition system	EI system	Ignition timing control	
Engine control module	ECM	ECCS control unit	BF
Engine coolant temperature	ECT	Engine temperature	
Engine coolant temperature sensor	ECTS	Engine temperature sensor	HA
Engine modification	EM	***	
Engine speed	RPM	Engine speed	EL
Erasable programmable read only memory	EPROM	***	
Evaporative emission system	EVAP system	Evaporative emission control system	IDX
Exhaust gas recirculation valve	EGR valve	EGR valve	

SAE J1930 TERMINOLOGY LIST

***: Not applicable

NEW TERM	NEW ACRONYM / ABBREVIATION	OLD TERM
Exhaust gas recirculation control -BPT valve	EGRC-BPT valve	BPT valve
Exhaust gas recirculation control -solenoid valve	EGRC-solenoid valve	EGR control solenoid valve
Exhaust gas recirculation temperature sensor	EGR temperature sensor	Exhaust gas temperature sensor
Flash electrically erasable programmable read only memory	FEEPROM	***
Flash erasable programmable read only memory	FEPRM	***
Flexible fuel sensor	FFS	***
Flexible fuel system	FF system	***
Heated oxygen sensor.	HO2S	Exhaust gas sensor
Idle air control system	IAC system	Idle speed control
Idle air control valve-air regulator	IACV-air regulator	Air regulator
Idle air control valve-auxiliary air control valve	IACV-AAC valve	Auxiliary air control(AAC) valve
Idle air control valve-FICD solenoid valve	IACV-FICD solenoid valve	FICD solenoid valve
Idle air control valve-idle up control solenoid valve	IACV-idle up control solenoid valve	idle up control solenoid valve
Idle speed control-FI pot	ISC-FI pot	FI pot
Idle speed control system	ISC system	***
Ignition control module	ICM	***
Indirect fuel injection system	IFI system	***
Intake air temperature sensor	IATS	Air temperature sensor
Knock	***	Detonation
Knock sensor	KS	Detonation sensor
Malfunction indicator lamp	MIL	Check engine light
Manifold absolute pressure	MAP	***
Manifold absolute pressure sensor	MAPS	***
Manifold differential pressure	MDP	***
Manifold differential pressure sensor	MDPS	***
Manifold surface temperature	MST	***
Manifold surface temperature sensor	MSTS	***
Manifold vacuum zone	MVZ	***
Manifold vacuum zone sensor	MVZS	***
Mass air flow sensor	MAFS	Air flow meter
Mixture control solenoid valve	MC solenoid valve	Air-fuel ratio control solenoid valve
Multiport fuel injection System	MFI system	Fuel injection control
Neutral position switch	***	Neutral switch
Non-volatile random access memory	NVRAM	***
On-board diagnostic system	OBD system	Self-diagnosis
Open loop	OL	Open loop
Oxidation catalyst	OC	Catalyst

SAE J1930 TERMINOLOGY LIST

***: Not applicable

NEW TERM	NEW ACRONYM / ABBREVIATION	OLD TERM	
Oxidation catalytic converter system	OC system	***	GI
Oxygen sensor	O2S	Exhaust gas sensor	
Park position switch	***	Park switch	
Park/neutral position switch	PNP switch	Park/neutral switch	MA
Periodic trap oxidizer system	PTOX system	***	
Powertrain control module	PCM	***	EM
Programmable read only memory	PROM	***	
Pulsed secondary air injection control solenoid valve	PAIRC solenoid valve	AIV control solenoid valve	LC
Pulsed secondary air injection system	PAIR system	Air induction valve(AIV) control	EF & EC
Pulsed secondary air injection valve	PAIR valve	Air induction valve	
Random access memory	RAM	***	
Read only memory	ROM	***	FE
Scan tool	ST	***	
Secondary air injection pump	AIR pump	***	CL
Secondary air injection system	AIR system	***	
Sequential multiport fuel injection system	SFI system	Sequential fuel injection	MT
Service reminder indicator	SRI	***	
Simultaneous multiport fuel injection system	***	Simultaneous fuel injection	AT
Smoke puff limiter system	SPL system	***	
Supercharger	SC	***	PD
Supercharger bypass	SCB	***	
System readiness test	SRT	***	
Thermal vacuum valve	TVV	Thermal vacuum valve	FA
Three way catalyst	TWC	Catalyst	
Three way catalytic converter system	TWC system	***	RA
Three way + oxidation catalyst	TWC + OC	Catalyst	
Three way + oxidation catalytic converter system	TWC + OC system	***	BR
Throttle body	TB	Throttle chamber SPI body	ST
Throttle body fuel injection system	TBI system	Fuel injection control	
Throttle position	TP	Throttle position	BF
Throttle position sensor	TPS	Throttle sensor	
Throttle position switch	TP switch	Throttle switch	HA
Torque converter clutch solenoid valve	TCC solenoid valve	Lock-up cancel solenoid Lock-up solenoid	EL
Turbocharger	TC	Turbocharger	
Vehicle speed sensor	VSS	Vehicle speed sensor	IDX
Volume air flow sensor	VAFS	Air flow meter	

SAE J1930 TERMINOLOGY LIST

***: Not applicable

NEW TERM	NEW ACRONYM / ABBREVIATION	OLD TERM
Warm up oxidation catalyst	WU-OC	Catalyst
Warm up oxidation catalytic converter system	WU-OC system	***
Warm up three-way catalyst	WU-TWC	Catalyst
Warm up three-way catalytic converter system	WU-TWC system	***
Wide open throttle position switch	WOTP switch	Full switch