

# MANUAL TRANSMISSION

## SECTION **MT**



### CONTENTS

PREPARATION .....	MT- 2
ON-VEHICLE SERVICE .....	MT- 4
REMOVAL AND INSTALLATION .....	MT- 5
MAJOR OVERHAUL .....	MT- 7
DISASSEMBLY .....	MT-12
INSPECTION .....	MT-20
ASSEMBLY .....	MT-22
TRANSMISSION OIL COOLER SYSTEM .....	MT-34
SERVICE DATA AND SPECIFICATIONS (S.D.S.) .....	MT-35

**MT**

# PREPARATION

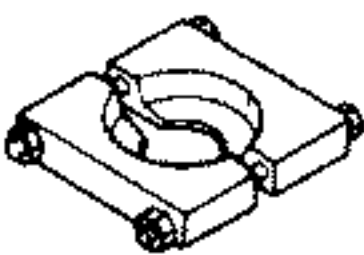
## SPECIAL SERVICE TOOLS

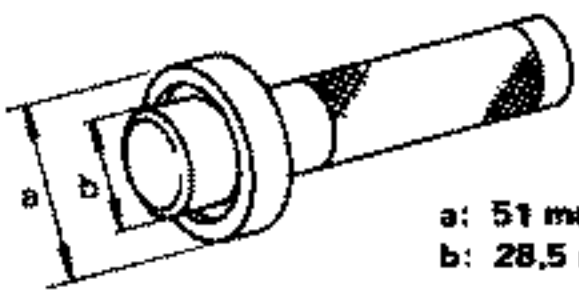
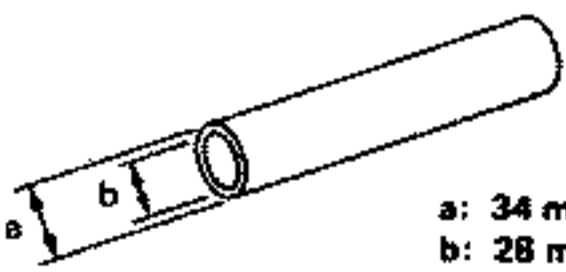
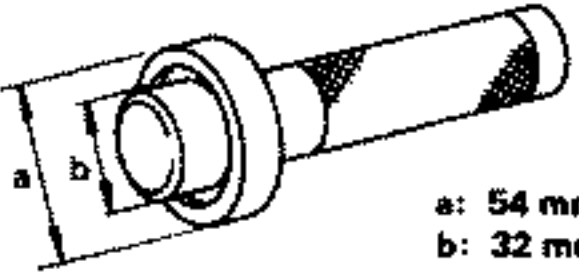
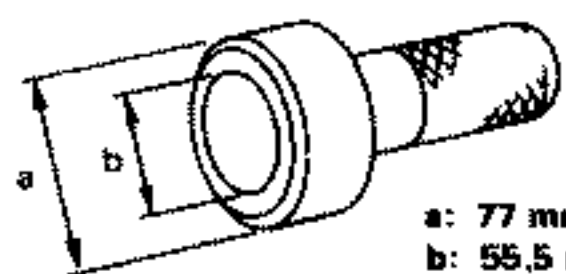
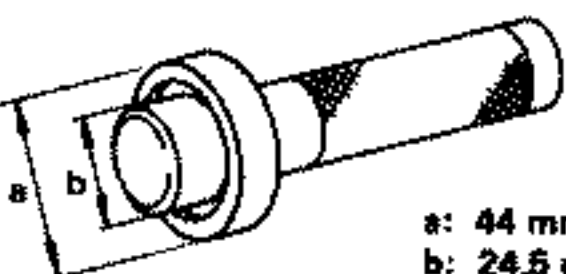
Tool number Tool name	Description
ST23540000 Pin punch	 <p style="text-align: right;">Removing and installing retaining pin</p>
ST30031000 Puller	 <p style="text-align: right;">Removing 1st &amp; 2nd synchronizer assembly Removing counter gear rear thrust bearing Removing main drive bearing Measuring 2nd &amp; 3rd inner baulk ring</p>
ST33290001 Puller	 <p style="text-align: right;">Removing rear oil seal</p>
ST33230000 Drift	 <p style="text-align: right;">Removing mainshaft and counter gear</p> <p style="text-align: center;">a: 51 mm (2.01 in) dia. b: 28,5 mm (1.122 in) dia.</p>
ST22350000 Drift	 <p style="text-align: right;">Removing counter gear front bearing (Use with KV38100300)</p> <p style="text-align: center;">a: 34 mm (1.34 in) dia. b: 26 mm (1.10 in) dia.</p>
KV38100300 Drift	 <p style="text-align: right;">Removing counter gear front bearing (Use with ST22350000) Installing counter gear rear bearing</p> <p style="text-align: center;">a: 54 mm (2.13 in) dia. b: 32 mm (1.26 in) dia.</p>
ST30720000 Drift	 <p style="text-align: right;">Removing mainshaft front bearing Installing mainshaft front bearing</p> <p style="text-align: center;">a: 77 mm (3.03 in) dia. b: 55,5 mm (2.185 in) dia.</p>
ST33210000 Drift	 <p style="text-align: right;">Installing counter gear front bearing Installing front cover oil seal</p> <p style="text-align: center;">a: 44 mm (1.73 in) dia. b: 24,5 mm (0.965 in) dia.</p>

## PREPARATION

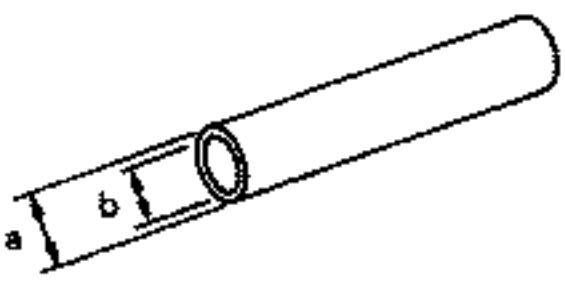
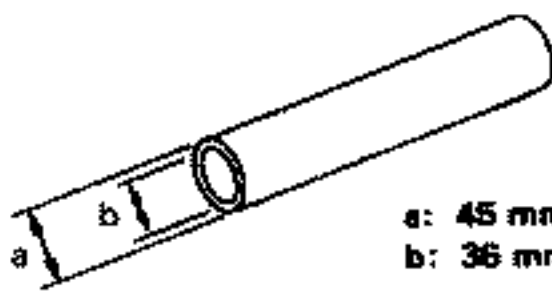
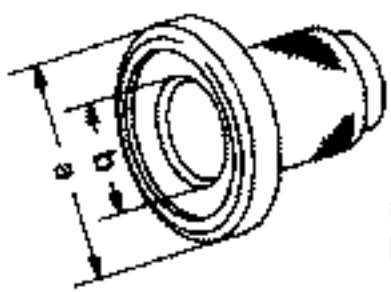
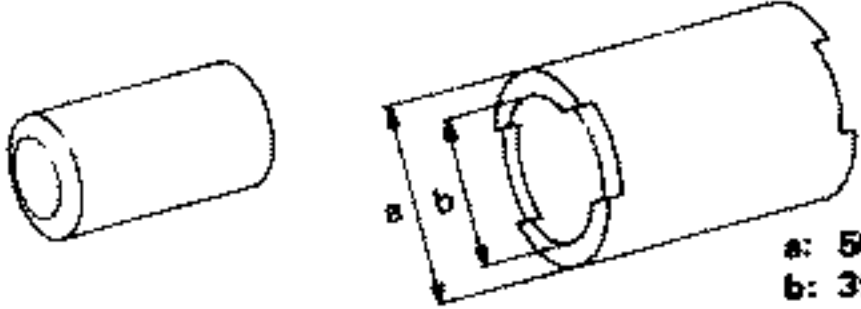
Tool number Tool name	Description
ST30613000 Drift	 <p>a: 72 mm (2.83 in) dia. b: 48 mm (1.89 in) dia.</p>
ST37750000 Drift	 <p>a: 40 mm (1.57 in) dia. b: 31 mm (1.22 in) dia.</p>
ST22452000 Drift	 <p>a: 45 mm (1.77 in) dia. b: 36 mm (1.42 in) dia.</p>
ST33400001 Drift	 <p>a: 60 mm (2.36 in) dia. b: 47 mm (1.85 in) dia.</p>
ST36730000 Drift	 <p>a: 50 mm (1.97 in) dia. b: 39 mm (1.54 in) dia.</p>

## COMMERCIAL SERVICE TOOLS

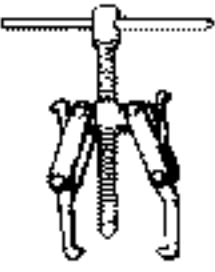
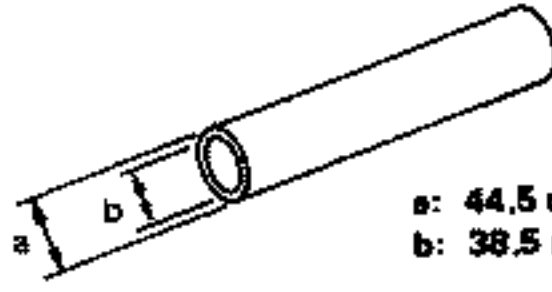
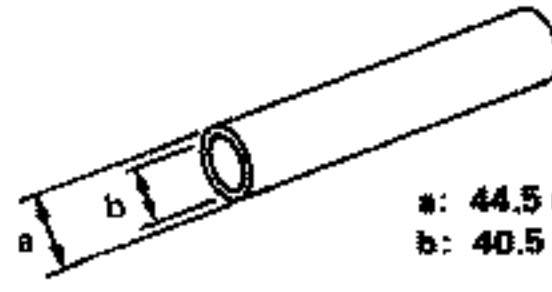
Tool name	Description
Puller	 <p>Removing counter gear rear end bearing Removing mainshaft rear bearing Removing reverse synchronizer hub Removing reverse counter gear</p>
Drift	 <p>a: 44.5 mm (1.752 in) dia. b: 38.5 mm (1.516 in) dia.</p>
Drift	 <p>a: 44.5 mm (1.752 in) dia. b: 40.5 mm (1.584 in) dia.</p>

## ON-VEHICLE SERVICE

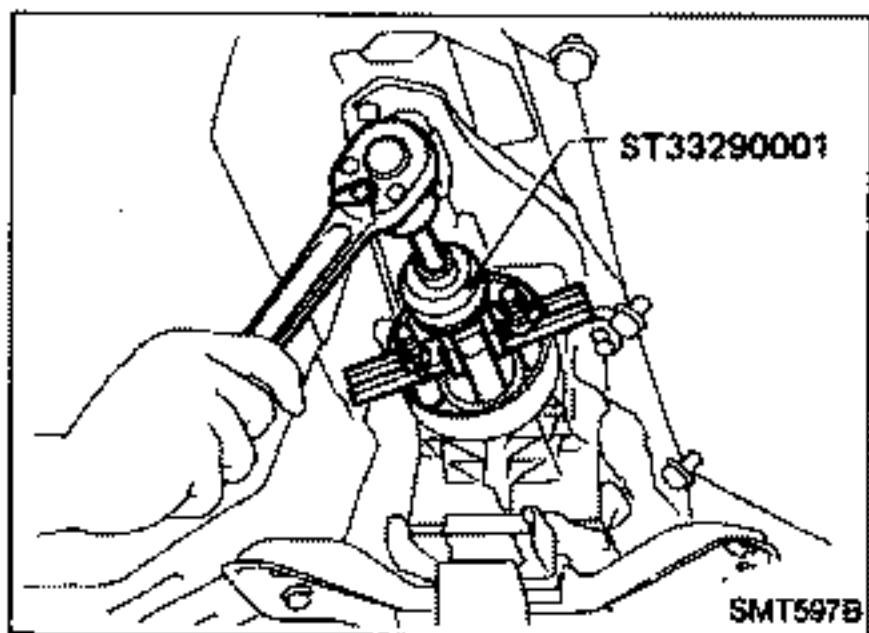

### Replacing Rear Oil Seal REMOVAL

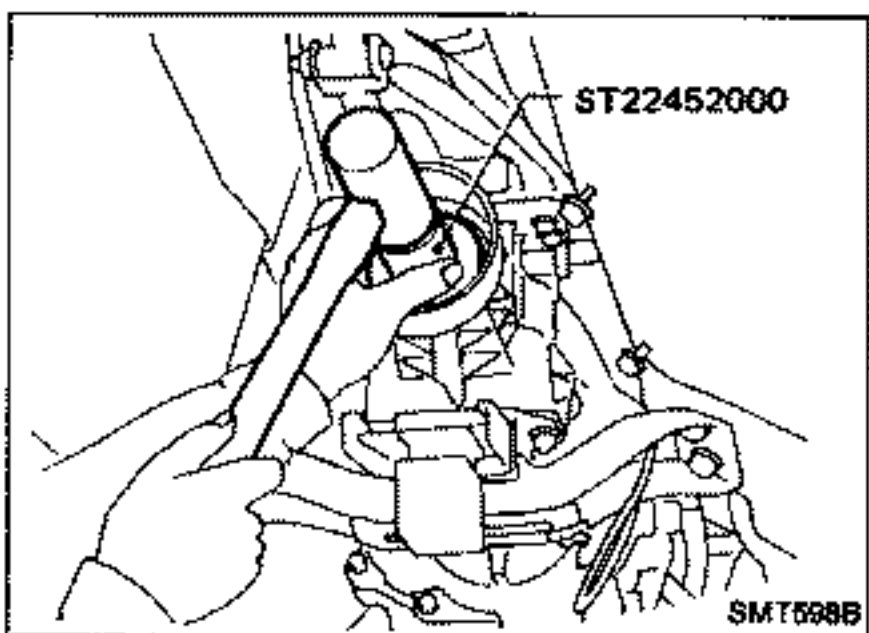

### INSTALLATION

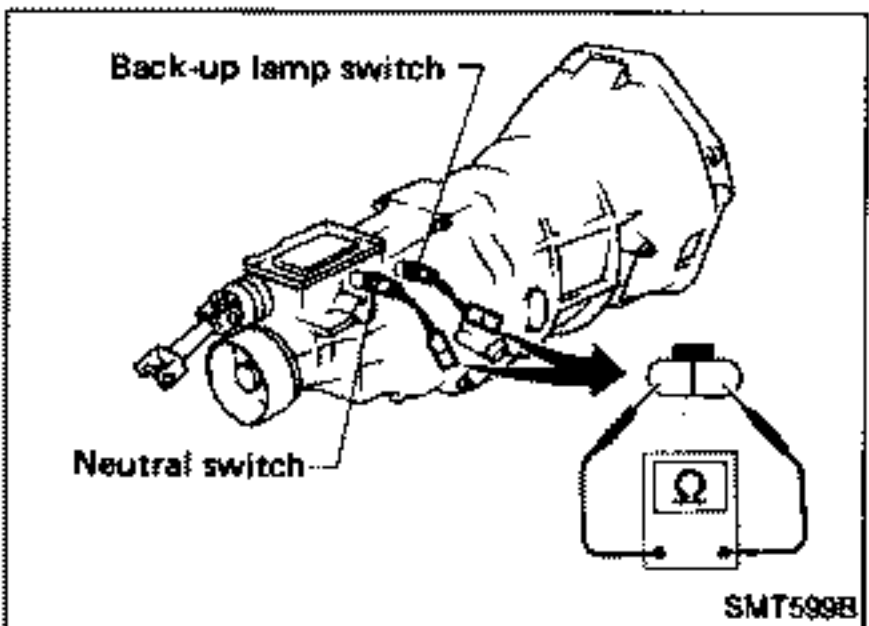

### Position Switch Check

#### BACK-UP LAMP SWITCH

- Check continuity.

Gear position	Continuity
Reverse	Yes
Except reverse	No

#### NEUTRAL SWITCH

- Check continuity.

Gear position	Continuity
Neutral	Yes
Except neutral	No

## REMOVAL AND INSTALLATION

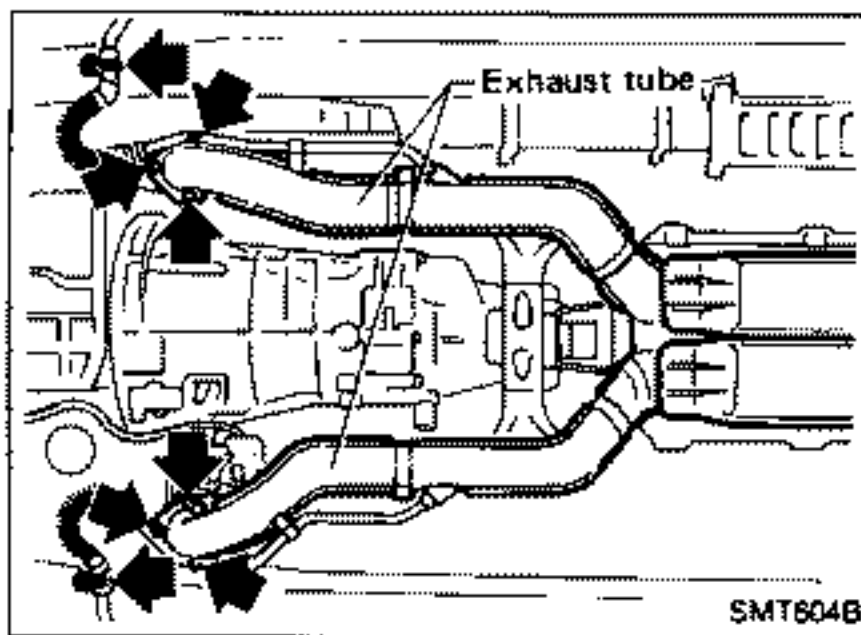

### Removal

- Remove exhaust tube.

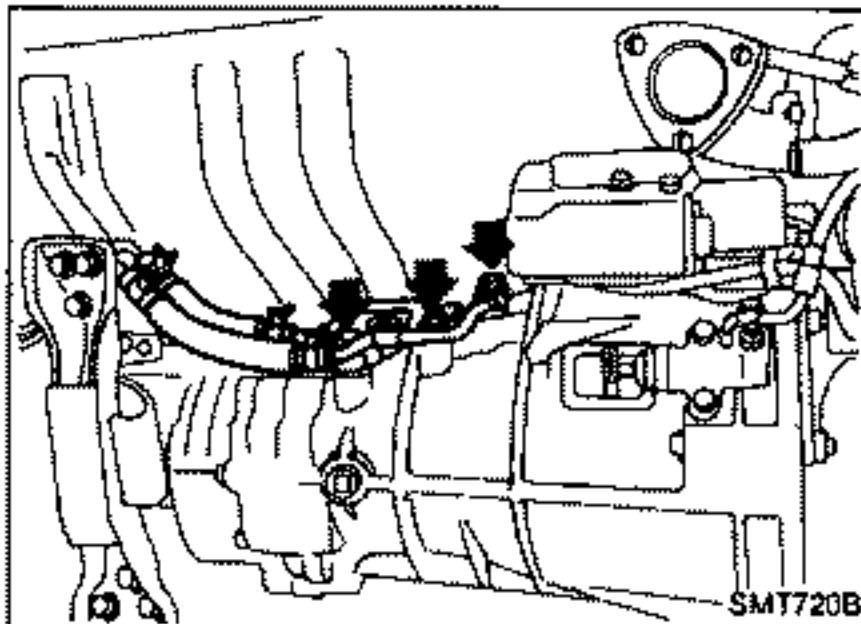

### Oil cooler equipped model only

- Drain gear oil.
- Disconnect oil tubes from transmission case.

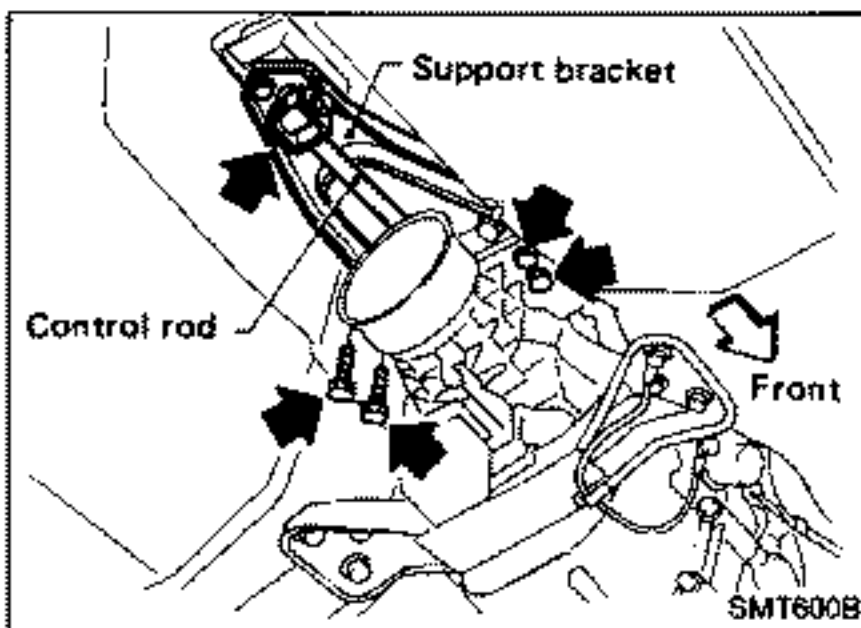

- Remove support bracket from M/T assembly.
- Remove control rod from shift lever.

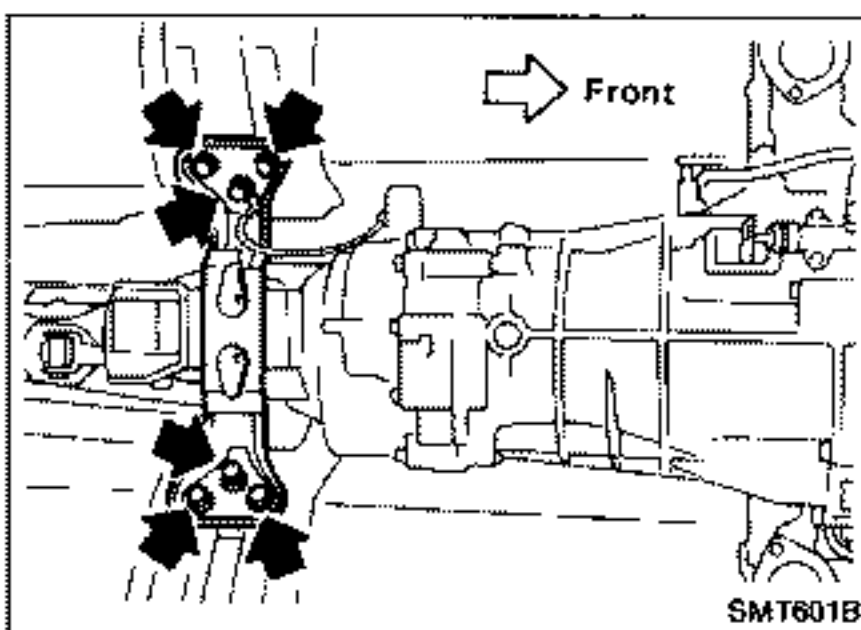

- Remove propeller shaft — Refer to section PD.
- Insert plug into rear oil seal after removing propeller shaft.
- Be careful not to damage spline, sleeve yoke and rear oil seal when removing propeller shaft.
- Disconnect back-up lamp switch and neutral switch harness connectors.
- Support manual transmission with a jack.
- Remove rear mounting.

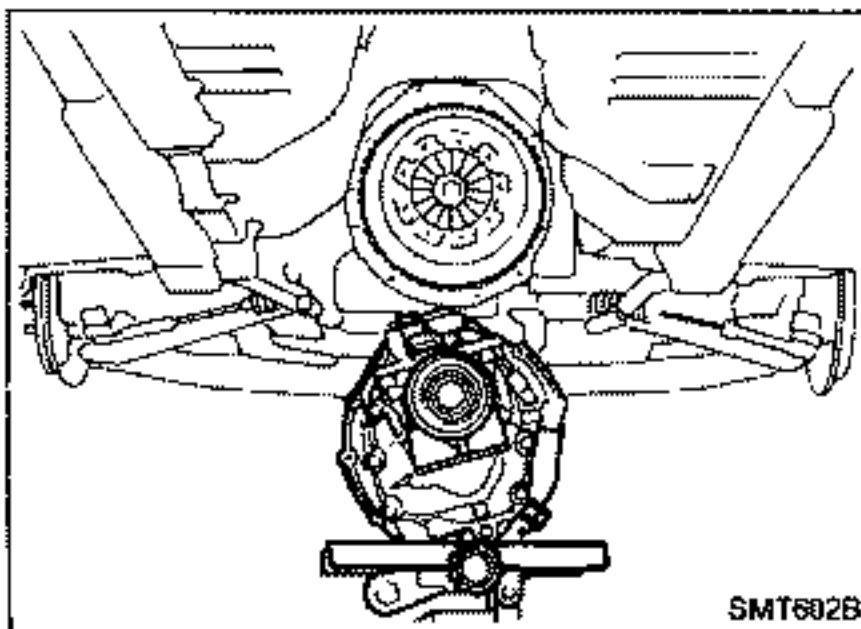

- Lower manual transmission.

# REMOVAL AND INSTALLATION

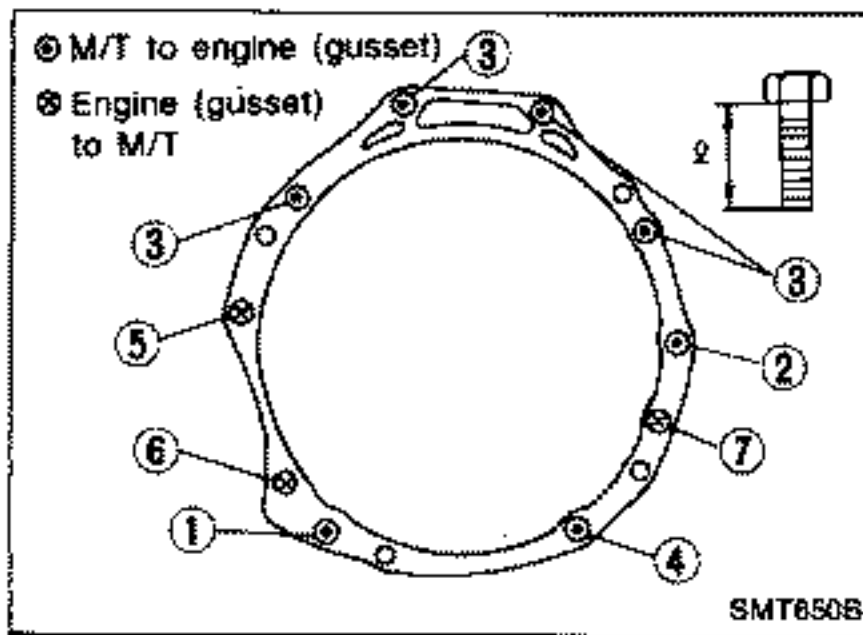

## Installation

- Tighten all transmission bolts.

Bolt No.	Tightening torque N·m (kg-m, ft-lb)	ℓ mm (in)
①	39 - 49 (4.0 - 5.0, 29 - 36)	100 (3.94)
②	39 - 49 (4.0 - 5.0, 29 - 36)	65 (2.56)
③	39 - 49 (4.0 - 5.0, 29 - 36)	60 (2.36)
④	29 - 39 (3.0 - 4.0, 22 - 29)	60 (2.36)
⑤	29 - 39 (3.0 - 4.0, 22 - 29)	55 (2.17)
⑥	39 - 49 (4.0 - 5.0, 29 - 36)	25 (0.98)
⑦	29 - 39 (3.0 - 4.0, 22 - 29)	25 (0.98)

- Fill with gear oil. (Oil cooler equipped model only)  
Refer to MA section.

# MAJOR OVERHAUL

## Case Components

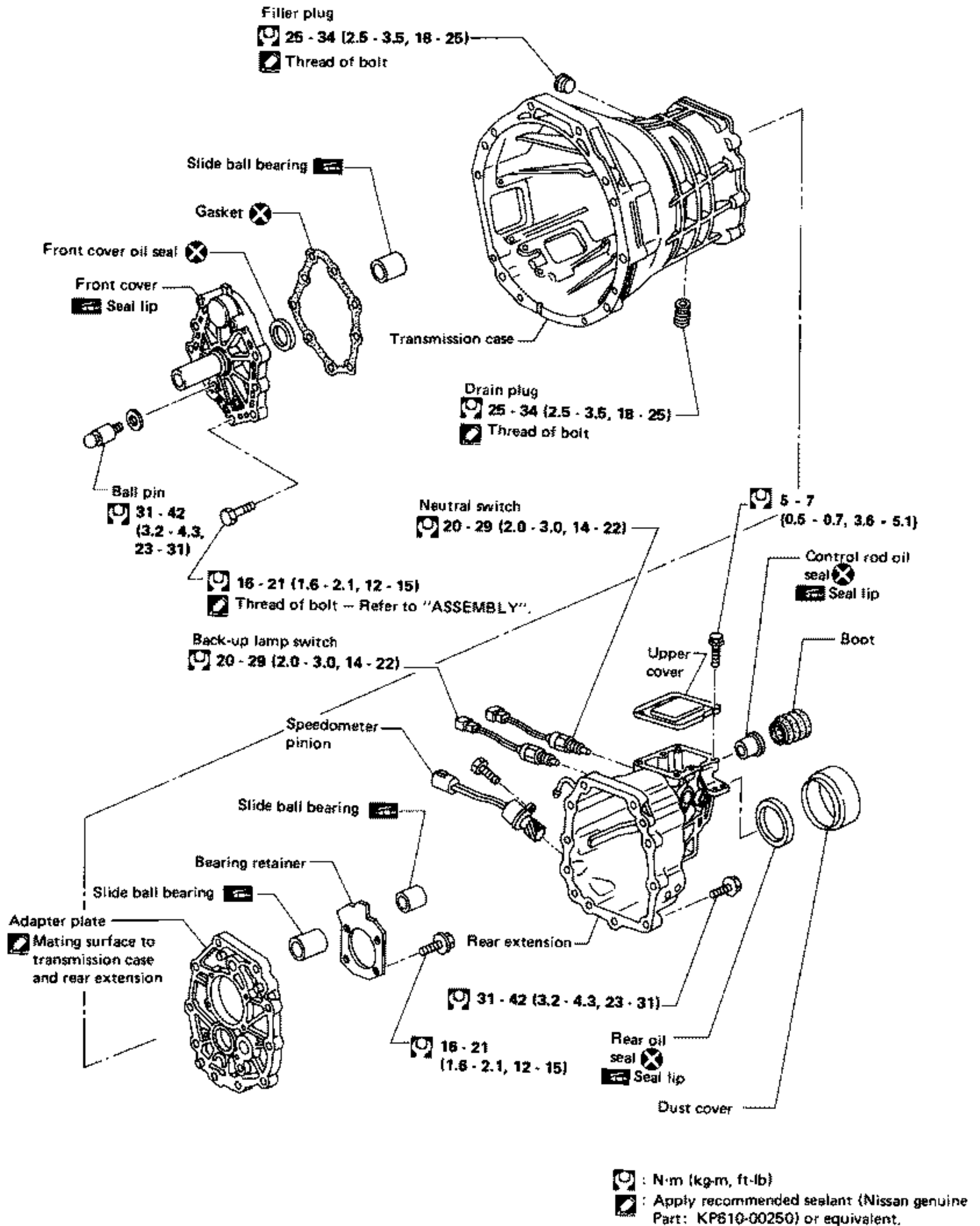

# MAJOR OVERHAUL

## Gear Components

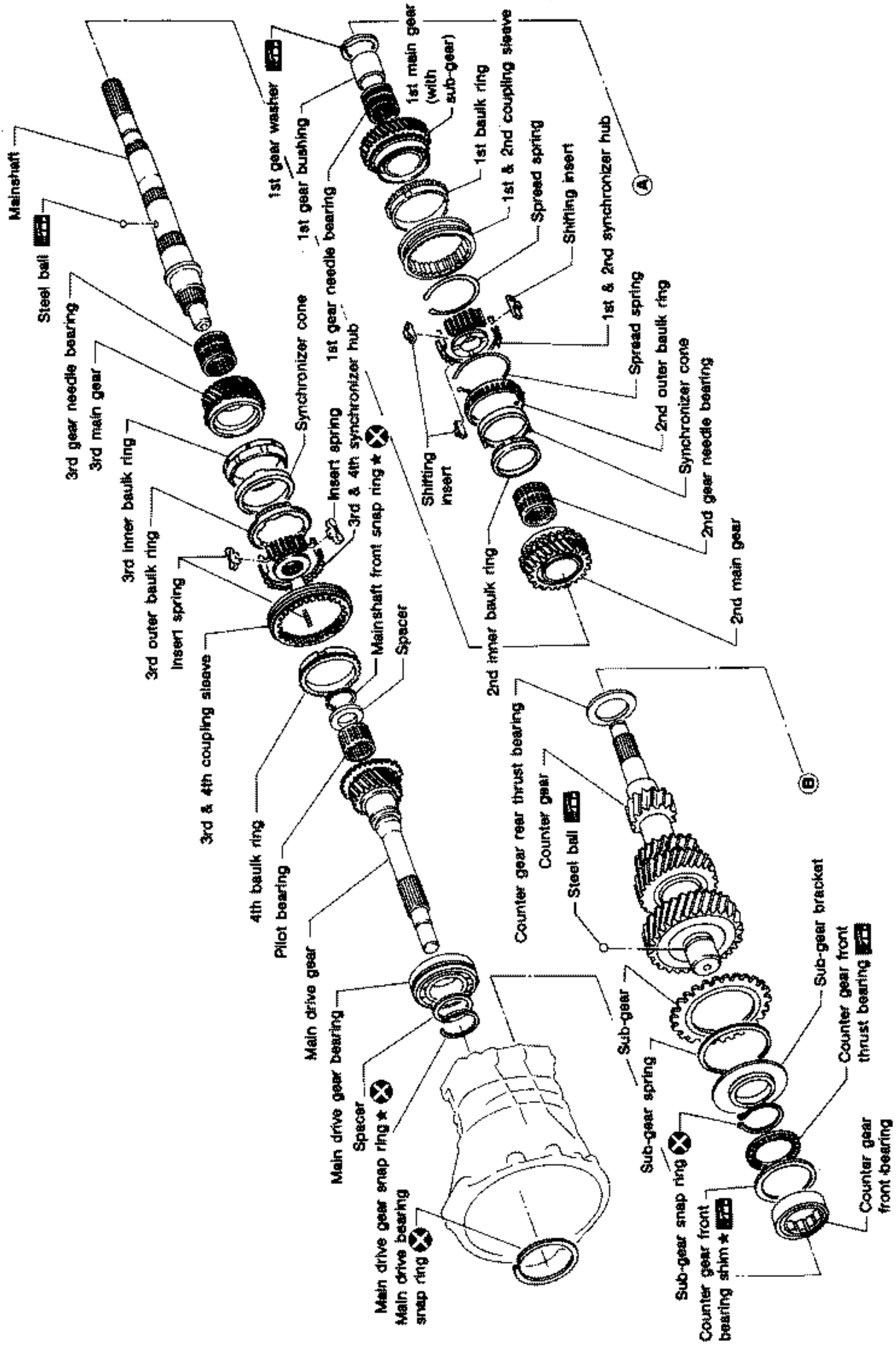



# MAJOR OVERHAUL

## Gear Components (Cont'd)

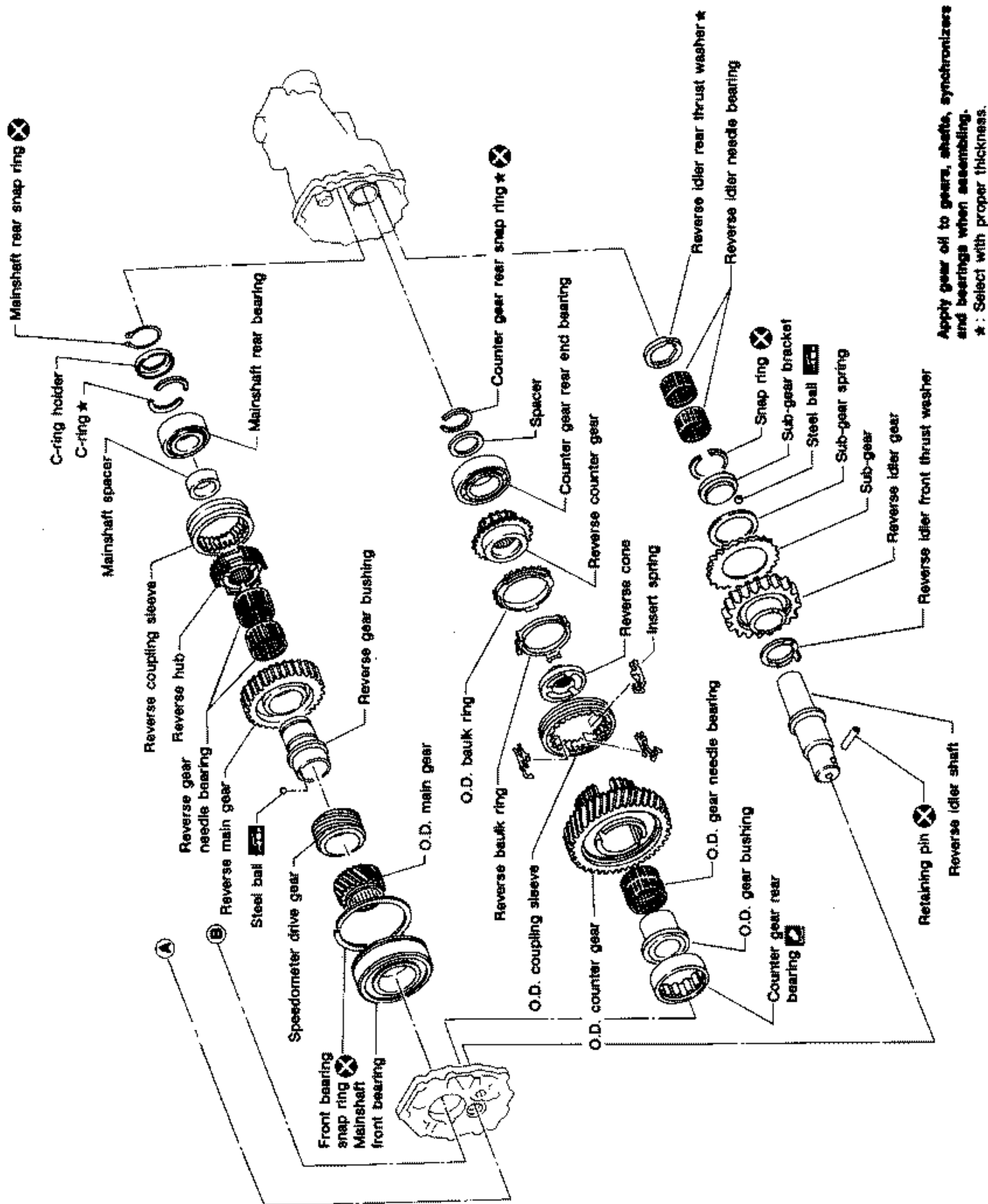

Apply gear oil to gears, shafts, synchronizers and bearings when assembling.  
 \* : Select with proper thickness.

# MAJOR OVERHAUL

## Shift Control Components

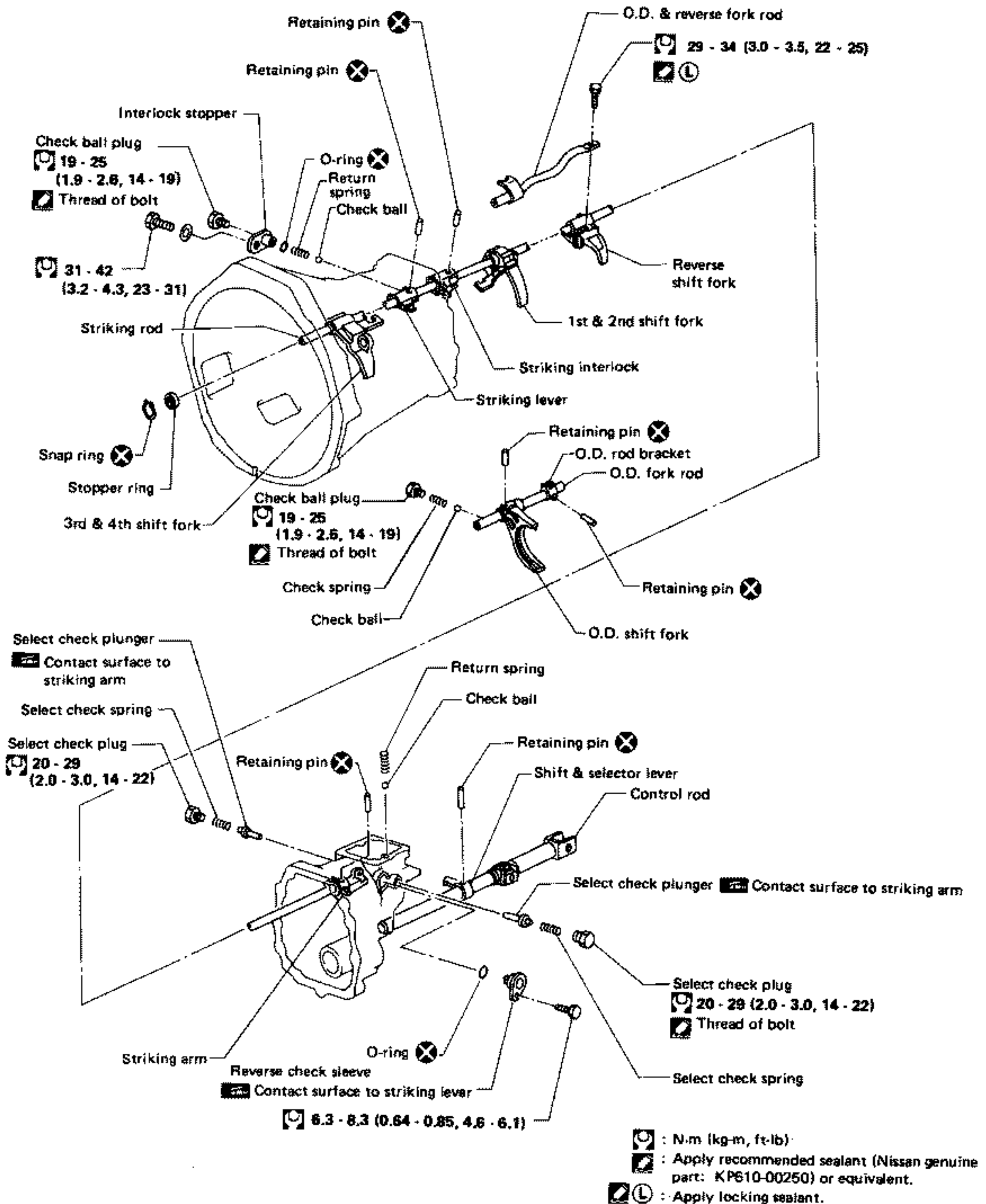

# MAJOR OVERHAUL

## Shift Control Components (Cont'd)

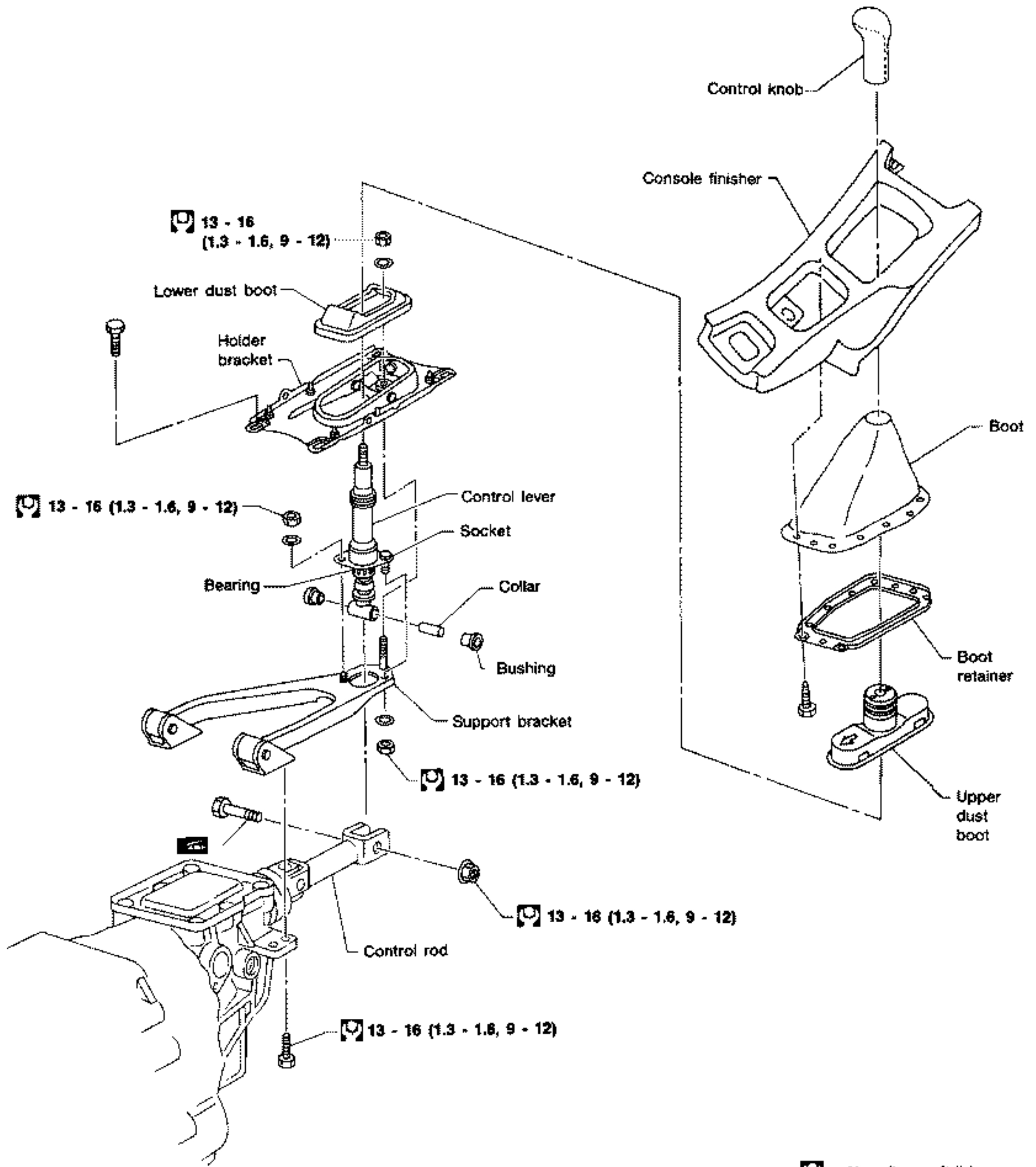

## DISASSEMBLY

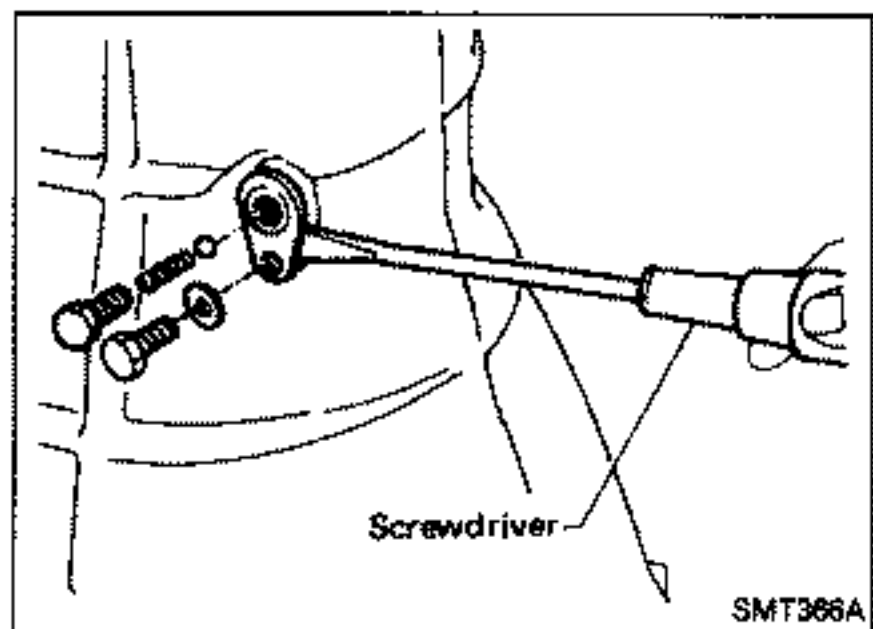

### Case Components

1. Remove check ball plug, check spring and check ball. Then remove interlock stopper.

**If interlock assembly is removed as a unit, the check ball can fall into transmission case.**

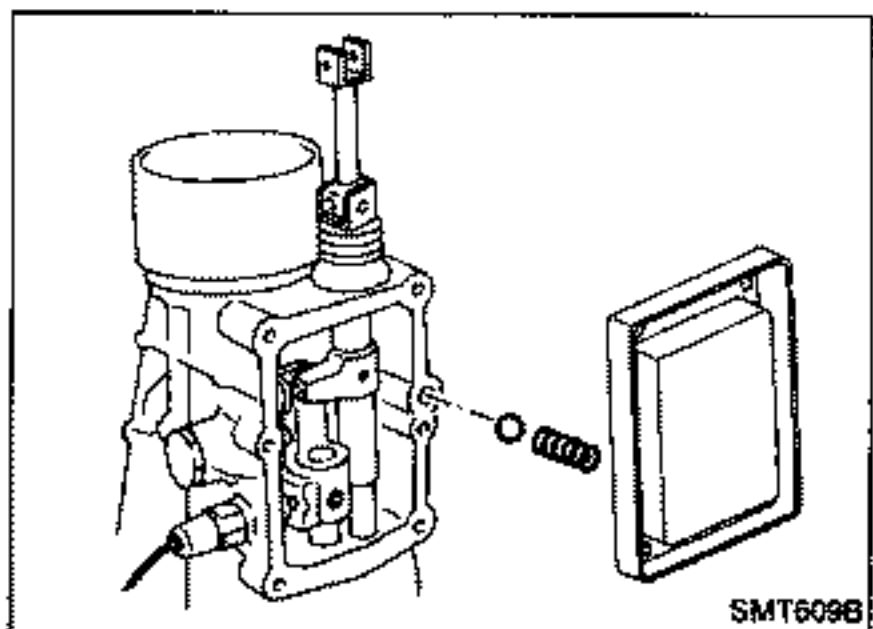

2. Remove upper cover, return spring and check ball.

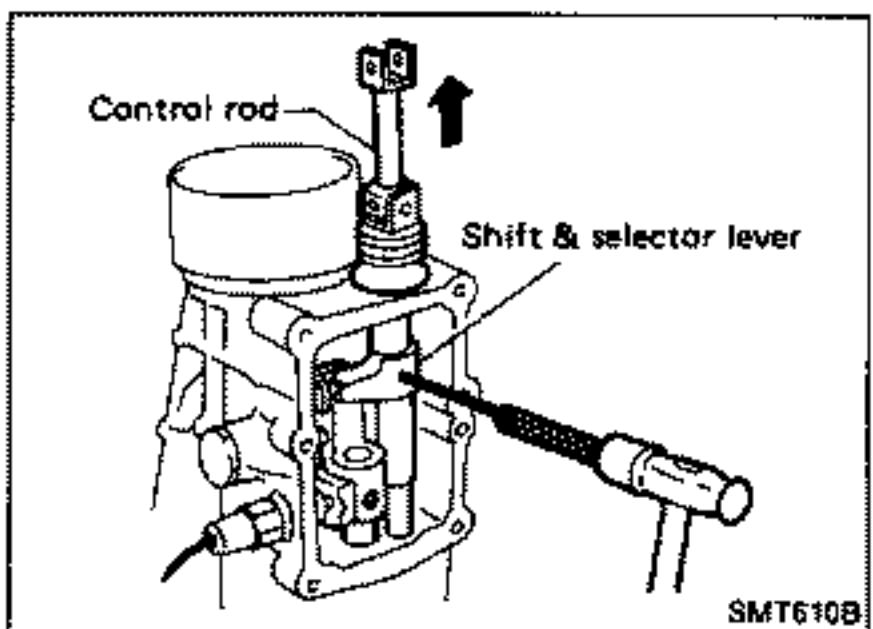

3. Drive out retaining pin from shift & selector lever.

4. Remove control rod from M/T assembly.

**Be careful not to damage control rod oil seal and dust cover.**

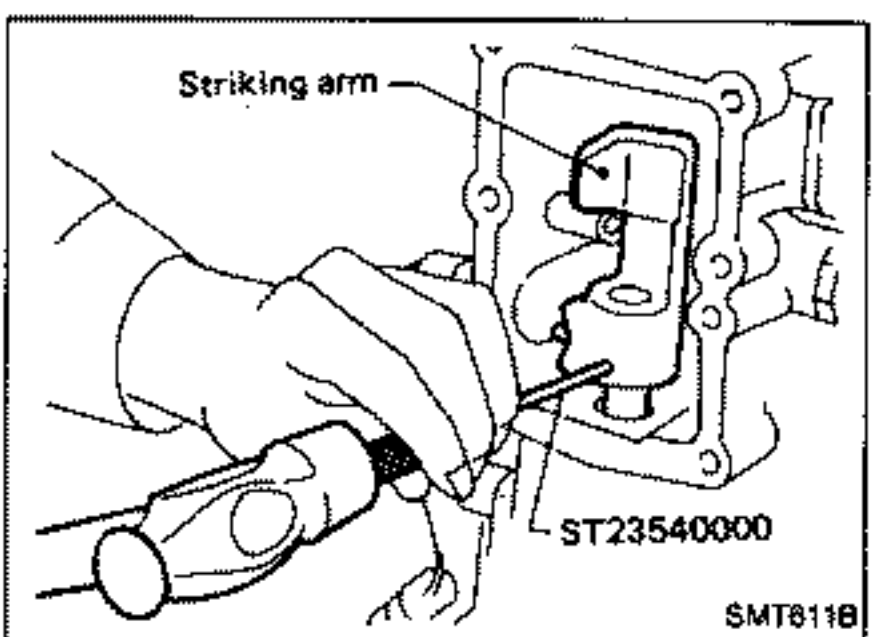

5. Drive out retaining pin from striking arm.

## DISASSEMBLY

### Case Components (Cont'd)

6. Remove rear extension together with striking arm by tapping lightly.

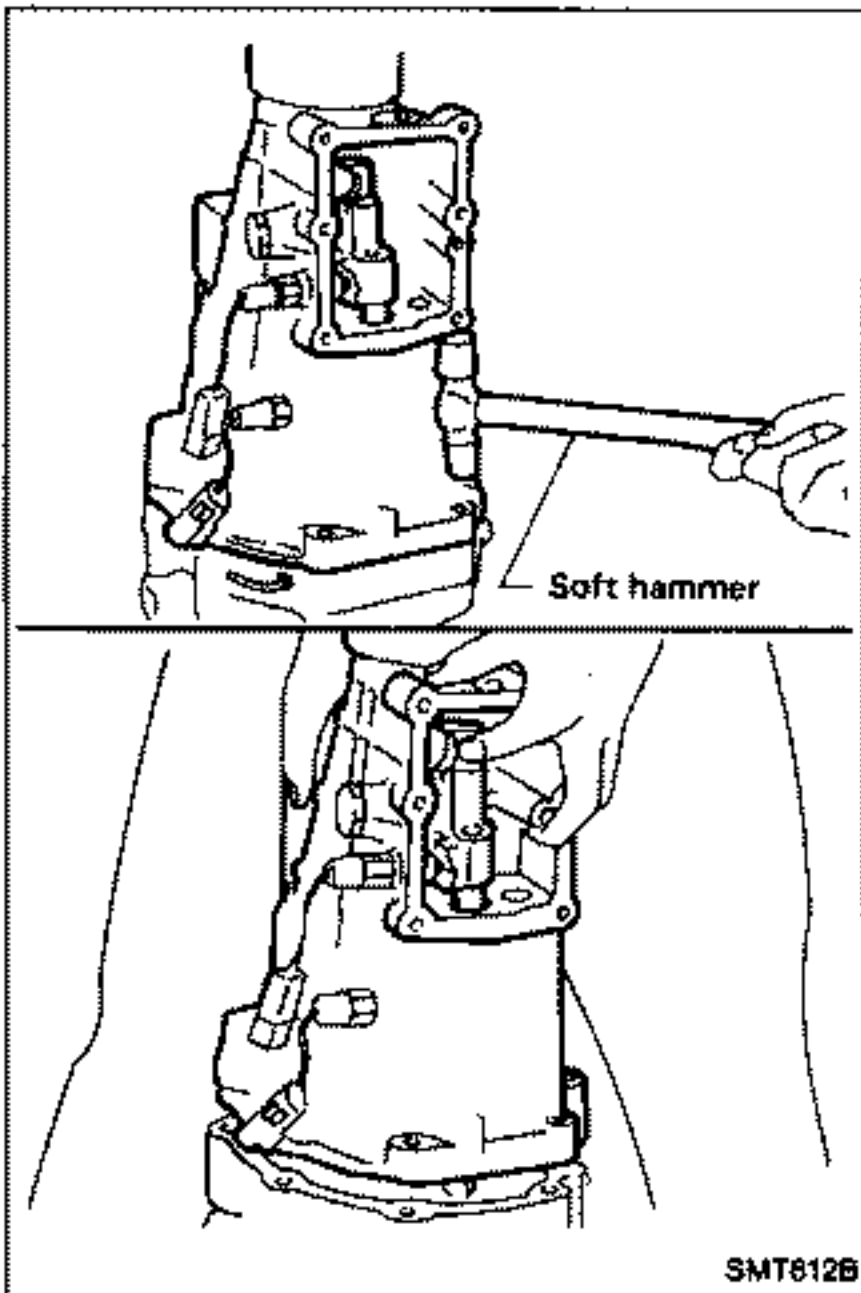

7. Remove front cover and gasket.

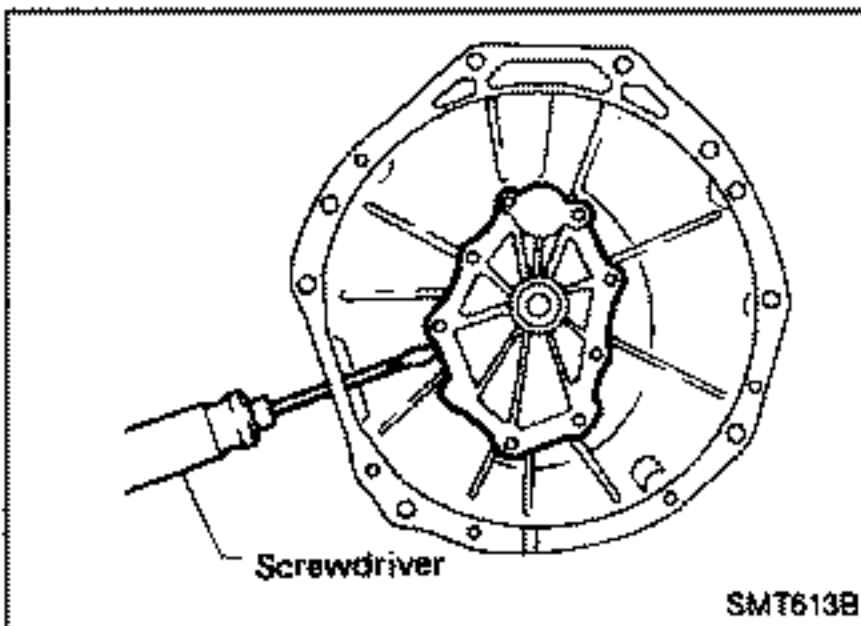

8. Remove stopper ring and main drive bearing snap ring.

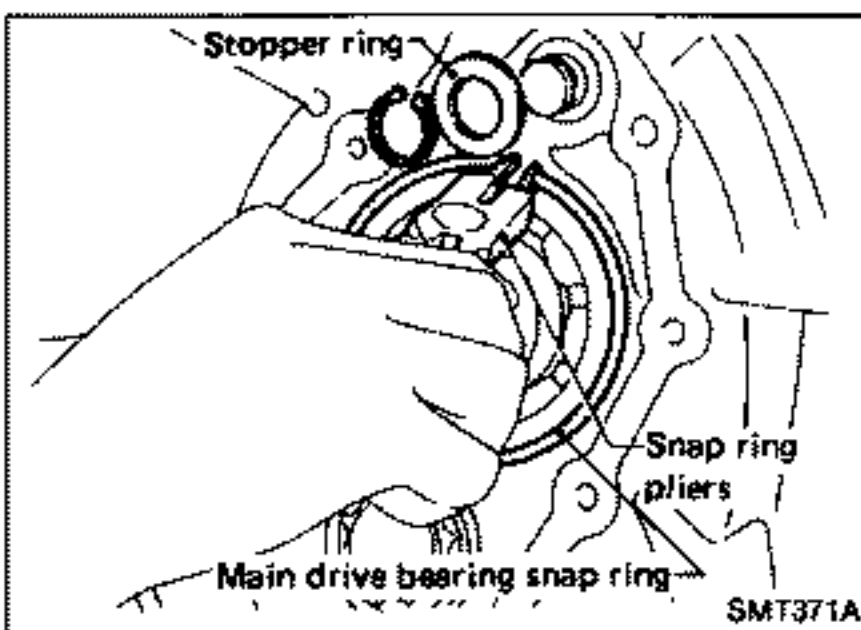

9. Remove transmission case by tapping lightly.

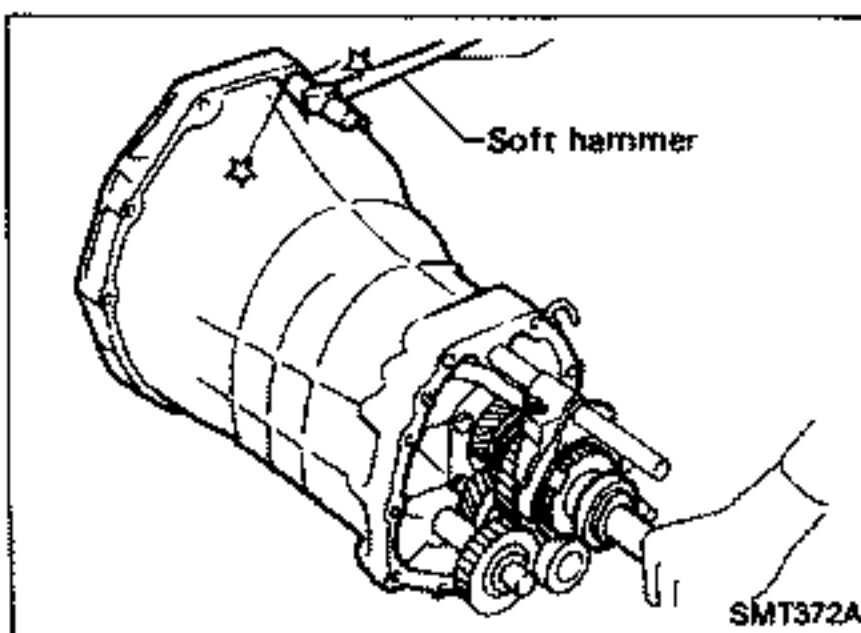

## DISASSEMBLY

### Case Components (Cont'd)

10. Remove front cover oil seal.

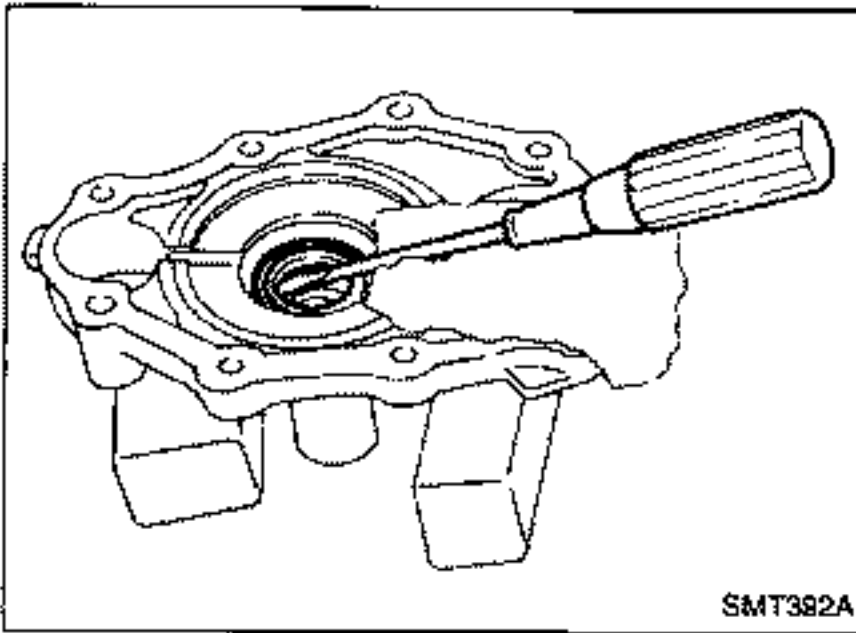

### Shift Control Components

1. Mount adapter plate on vise.
2. Remove O.D. & reverse fork rod.

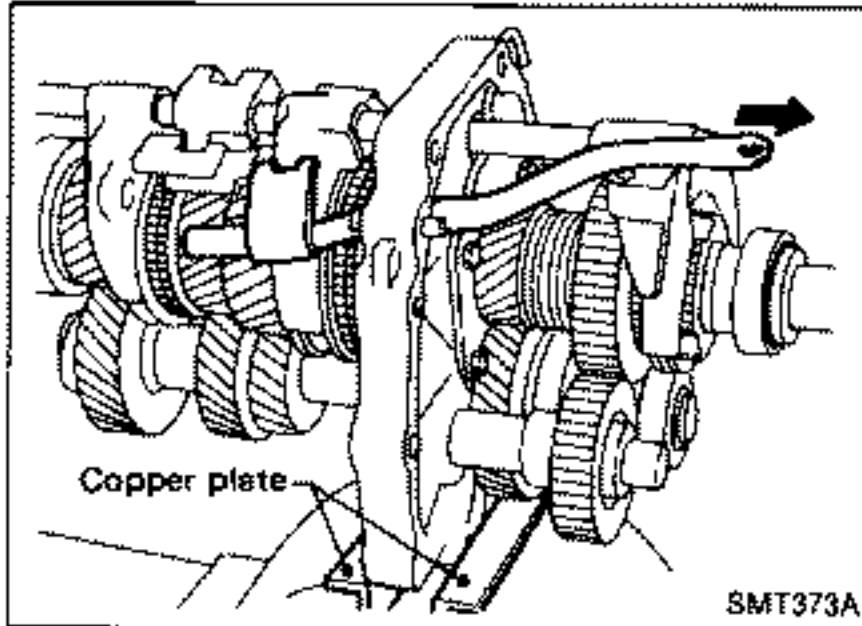

3. Remove check ball plug, check ball and return spring.

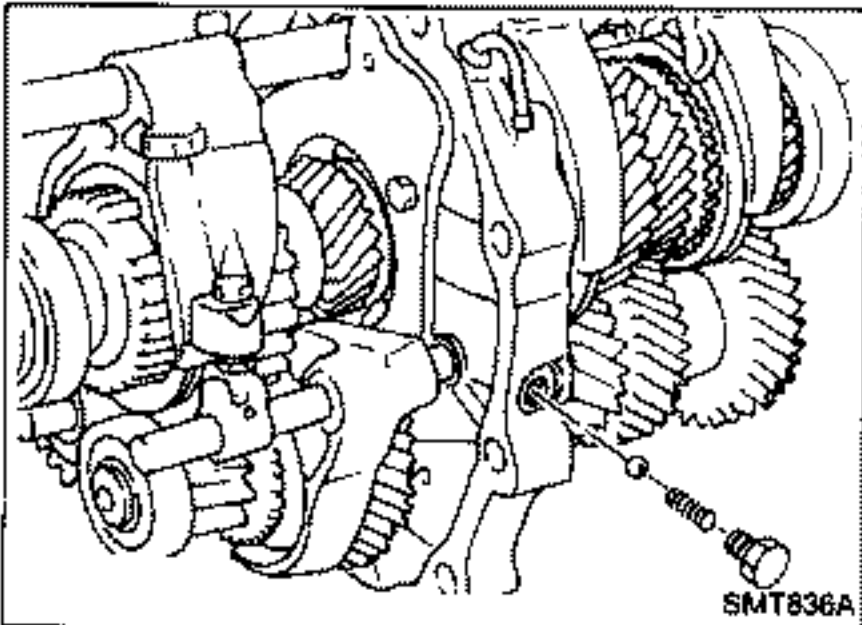

4. Drive out retaining pin from striking lever.
5. While pulling out striking rod, remove striking lever and striking interlock. Then remove 1st & 2nd, 3rd & 4th and reverse shift forks.

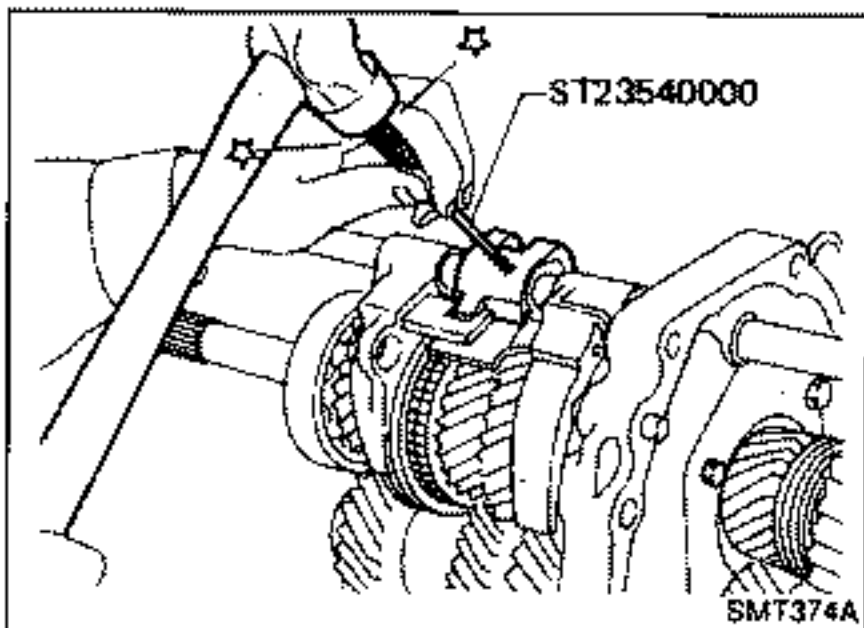

6. Drive out retaining pin from O.D. shift fork.
7. Pull out O.D. fork rod and then remove O.D. shift fork.

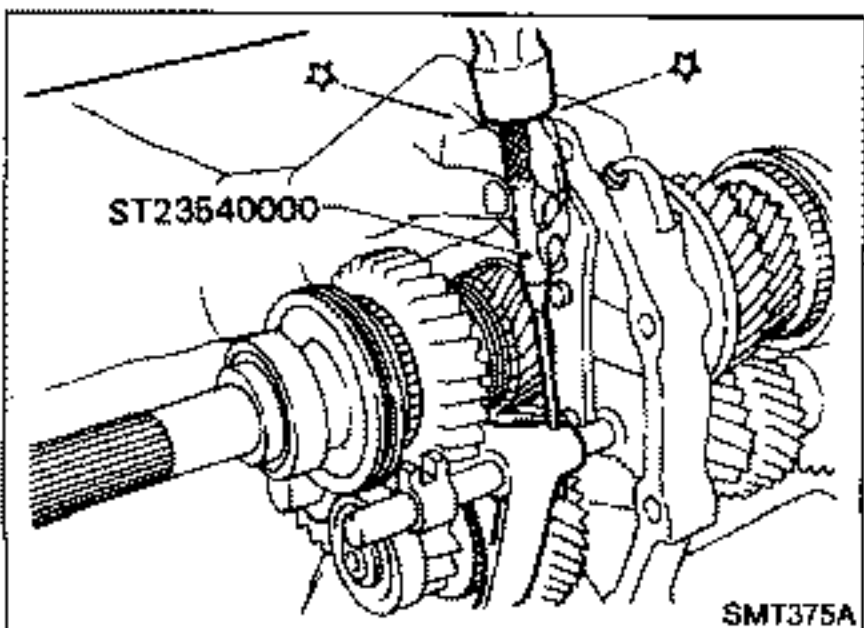

## DISASSEMBLY

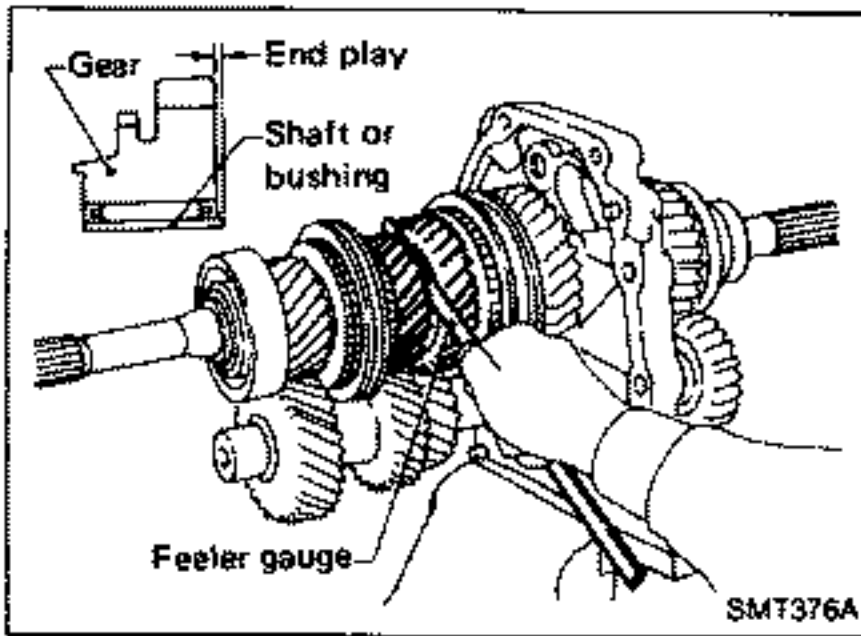

### Gear Components

1. Before removing gears and shafts, measure each gear end play.

Gear	End play mm (in)
1st main gear	0.23 - 0.33 (0.0091 - 0.0130)
2nd main gear	0.23 - 0.33 (0.0091 - 0.0130)
3rd main gear	0.23 - 0.33 (0.0091 - 0.0130)
O.D. counter gear	0.23 - 0.33 (0.0091 - 0.0130)
Reverse main gear	0.33 - 0.43 (0.0130 - 0.0169)

- If not within specification, disassemble and check contact surface of gear to hub, washer, bushing, needle bearing and shaft.

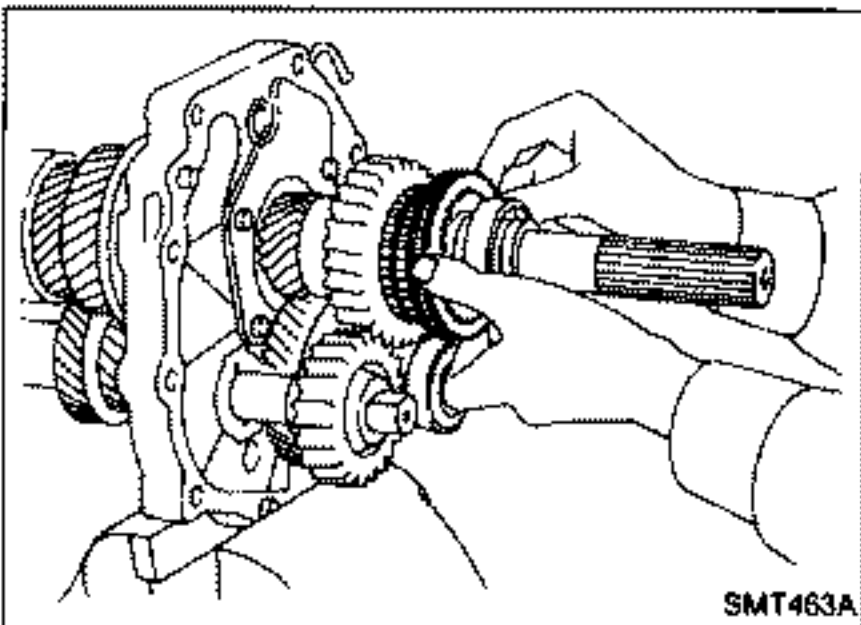

2. Remove rear side components on mainshaft and counter gear.
  - a. Remove snap ring, speedometer drive gear and steel ball.
  - b. Remove reverse coupling sleeve.

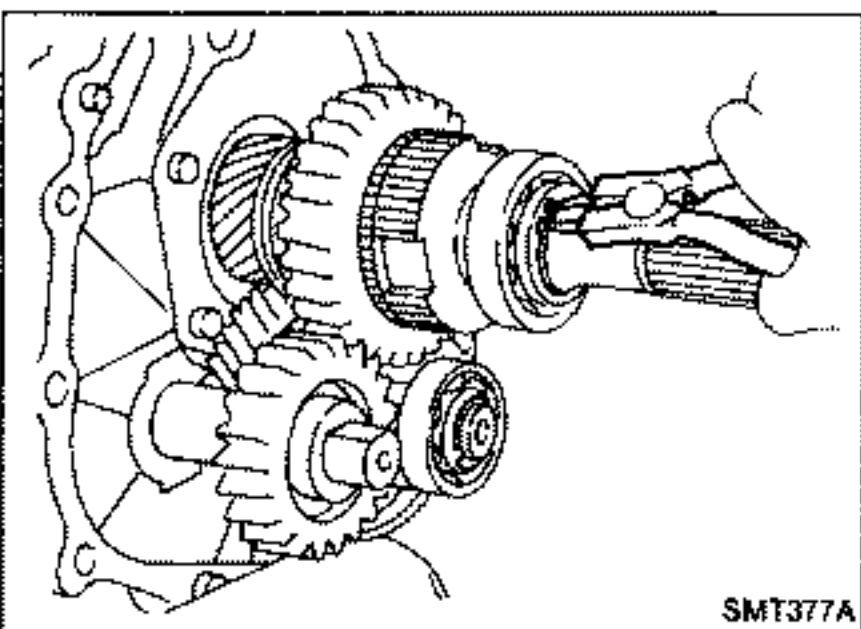

- c. Remove mainshaft rear snap ring and counter gear rear snap ring.
- d. Remove C-ring holder and mainshaft C-rings from mainshaft. Use punch and hammer to remove C-rings.

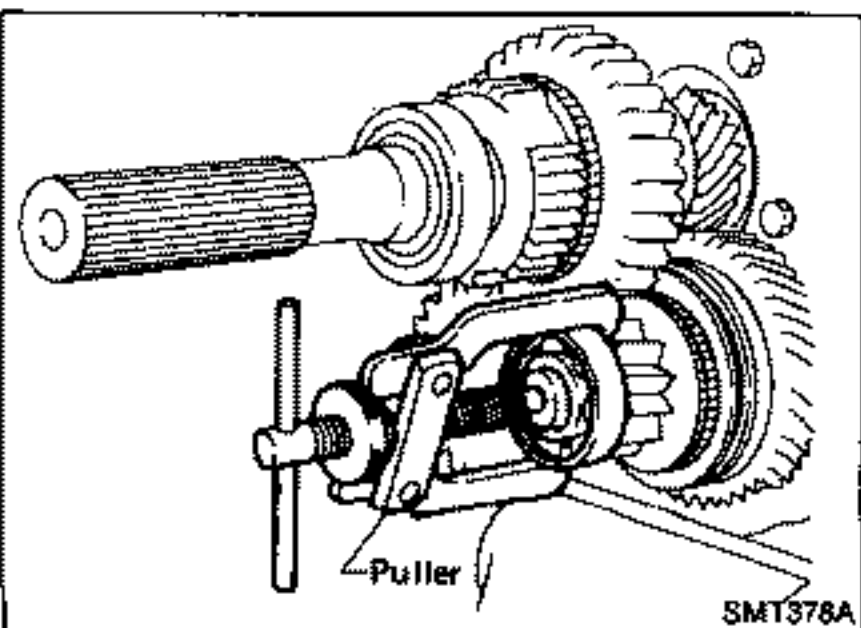

- e. Pull out counter gear rear end bearing.
- f. Remove reverse idler gear and reverse idler thrust washers.

## DISASSEMBLY

### Gear Components (Cont'd)

- g. Remove sub-gear from reverse idler gear.

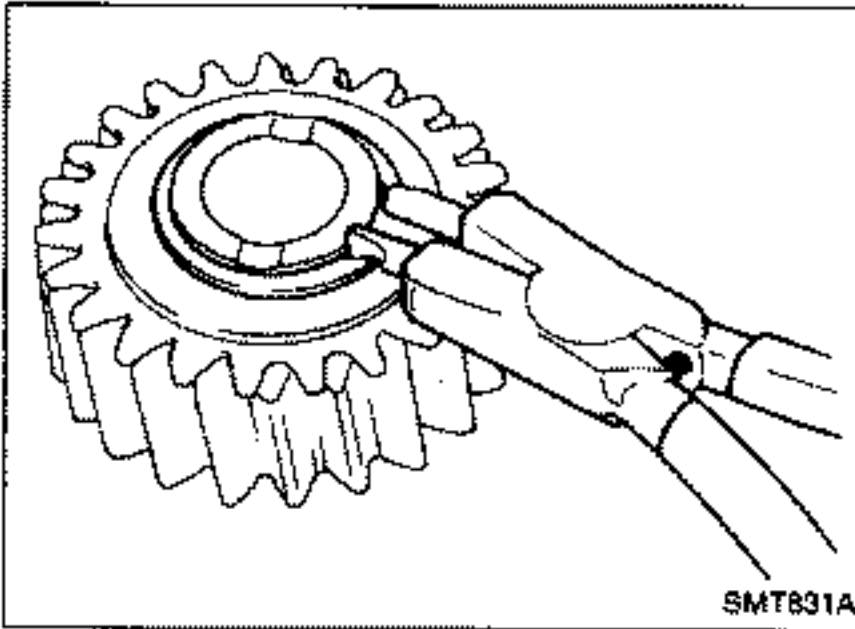

- h. Pull out mainshaft rear bearing.

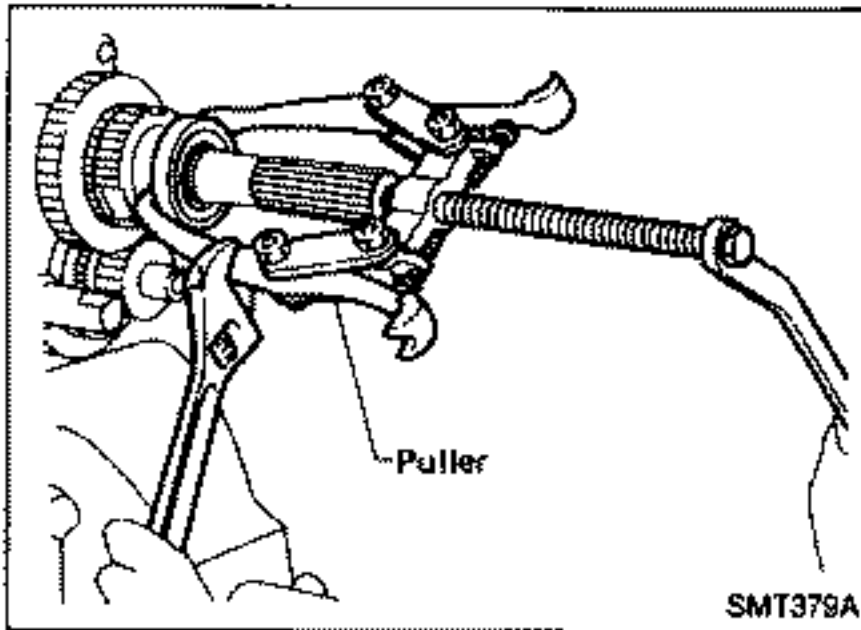

- i. Pull out reverse main gear together with mainshaft spacer and reverse synchronizer hub. Then remove reverse gear needle bearings.

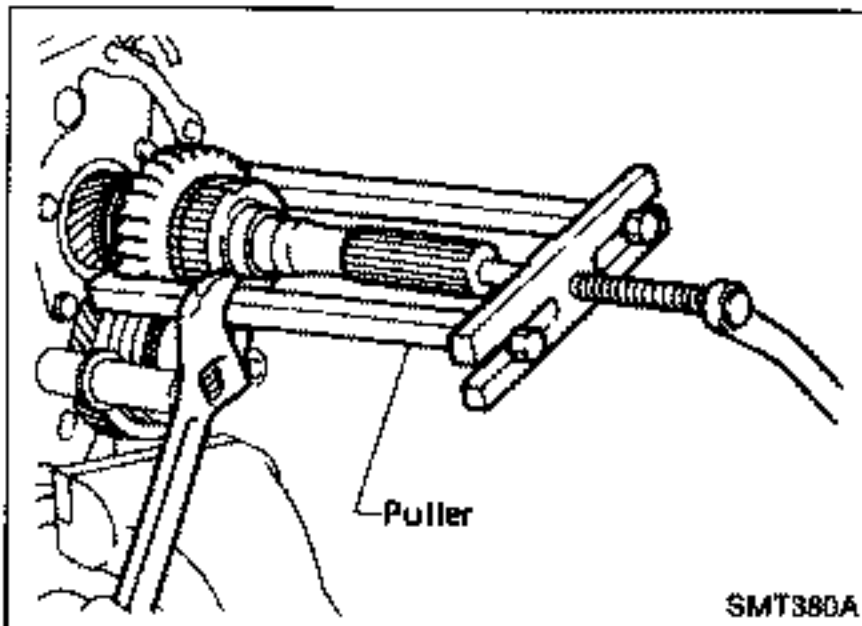

- j. Pull out reverse counter gear.  
k. Remove O.D. coupling sleeve together with O.D. baulk ring, reverse baulk ring and spring inserts.

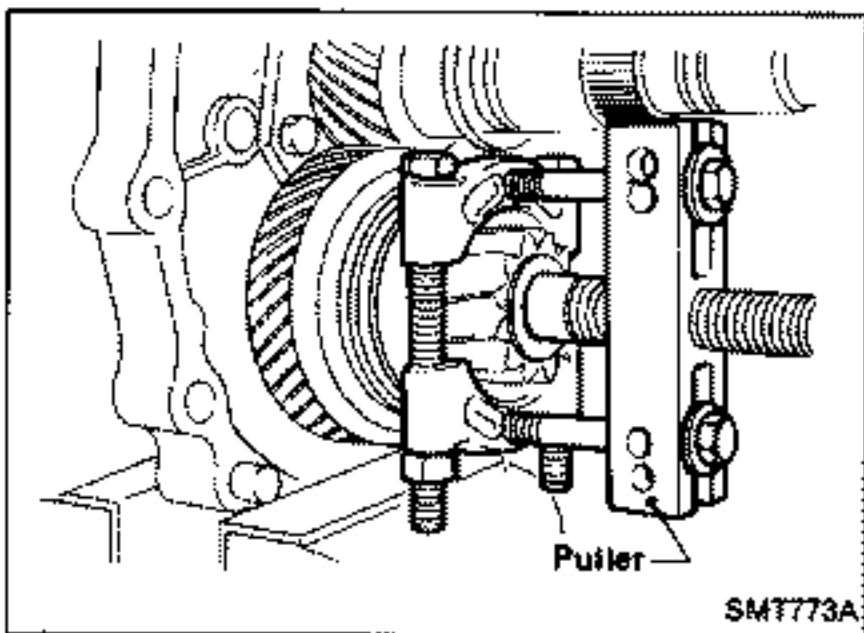

- l. Pull out reverse gear bushing.

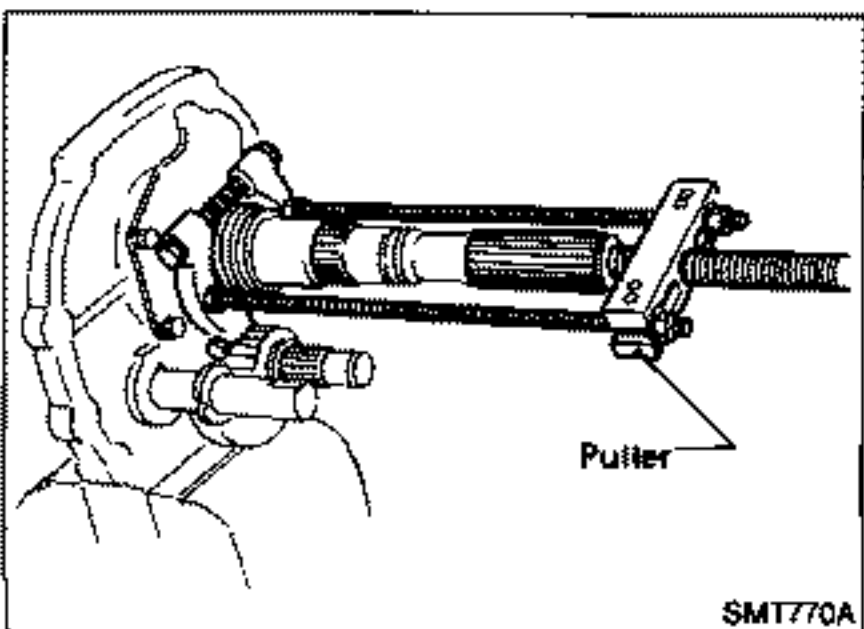



## DISASSEMBLY

### Gear Components (Cont'd)

m. Pull out O.D. counter gear together with reverse cone.

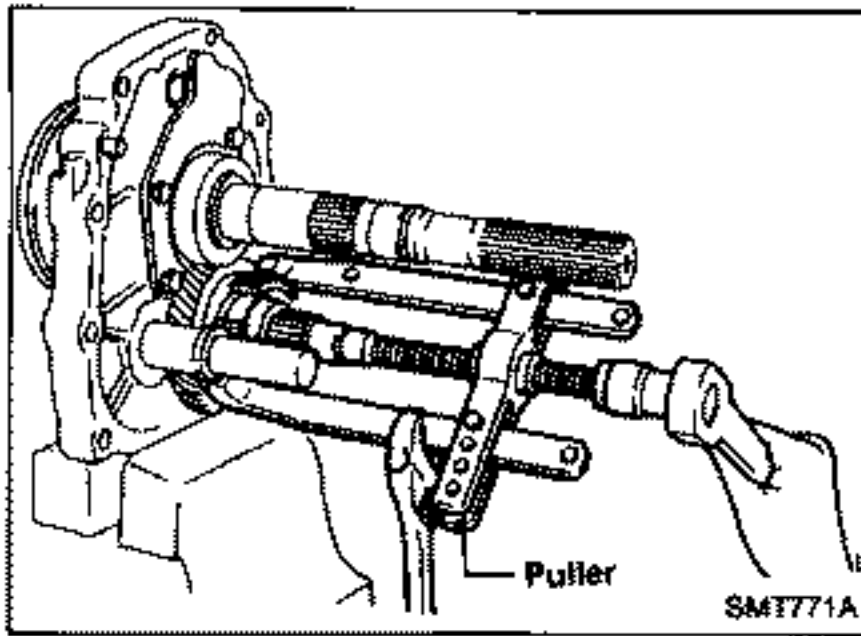

3. Press out mainshaft and counter gear alternately.

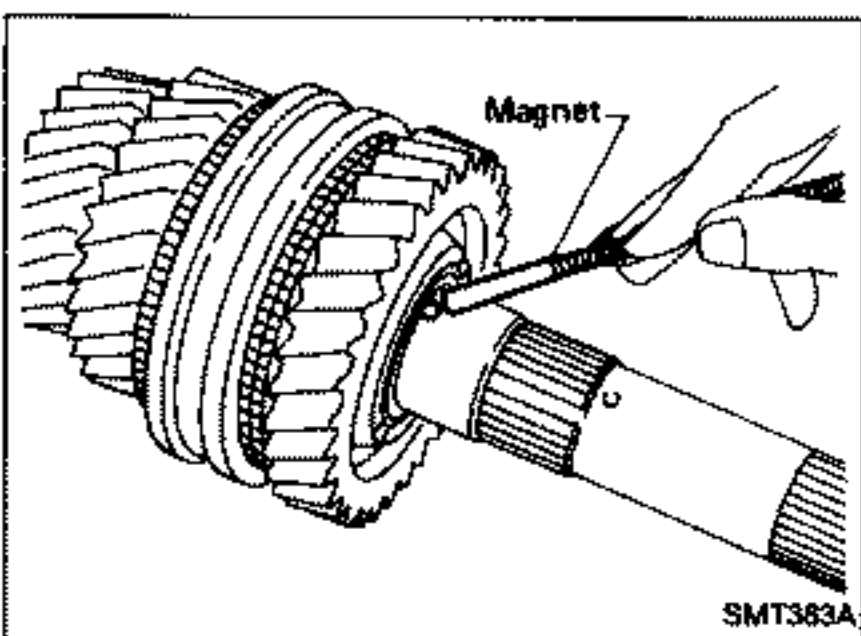
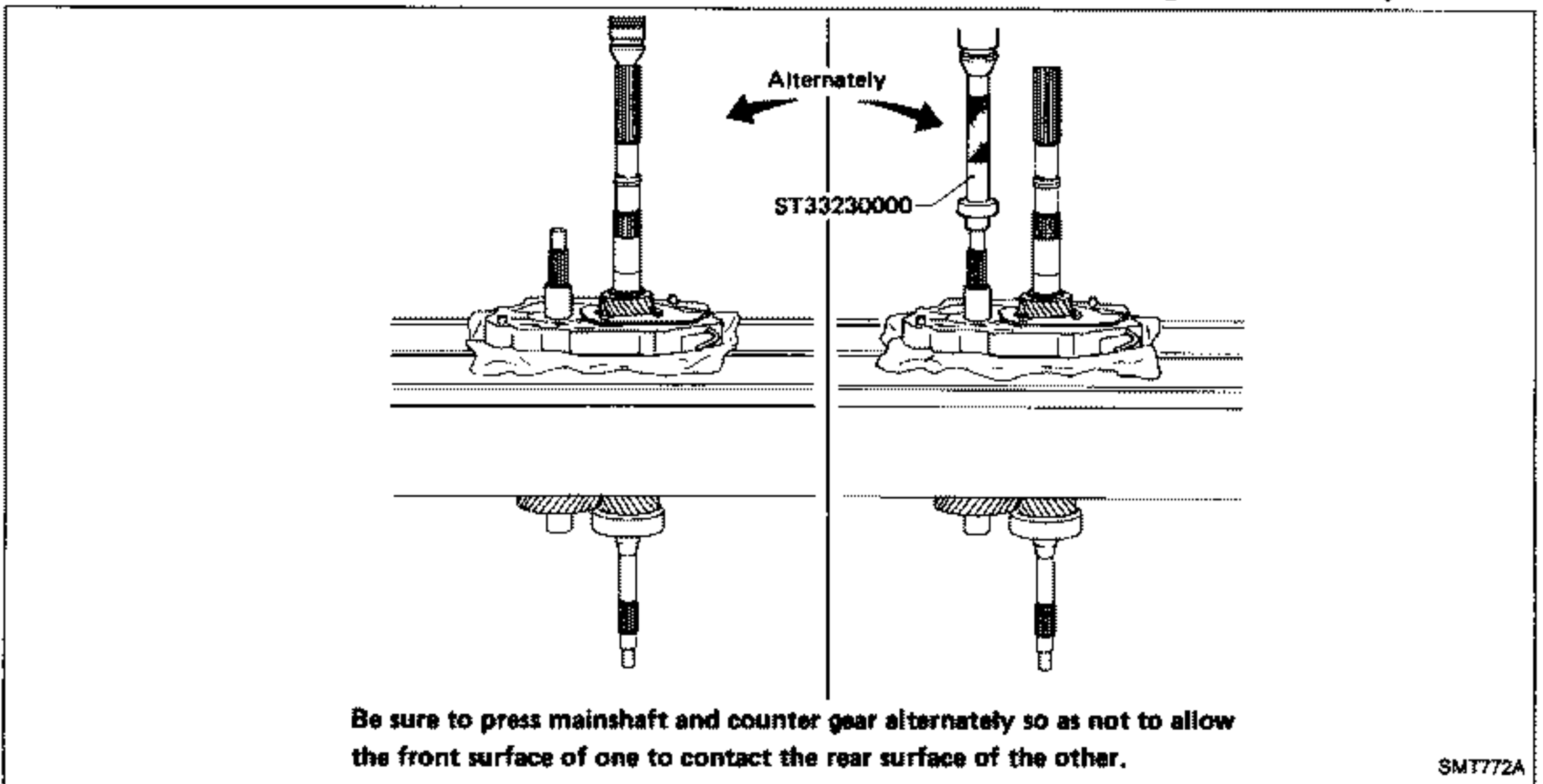

4. Remove front side components on mainshaft.

- Remove 1st gear washer and steel ball.
- Remove 1st main gear and 1st gear needle bearing.

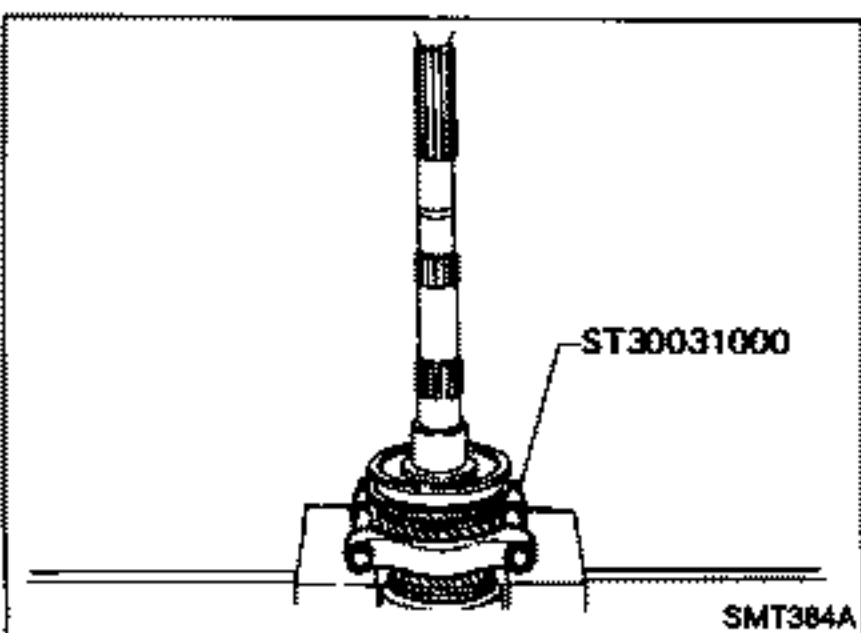

- Press out 2nd main gear together with 1st gear bushing and 1st & 2nd synchronizer assembly.
- Remove mainshaft front snap ring.

## DISASSEMBLY

### Gear Components (Cont'd)

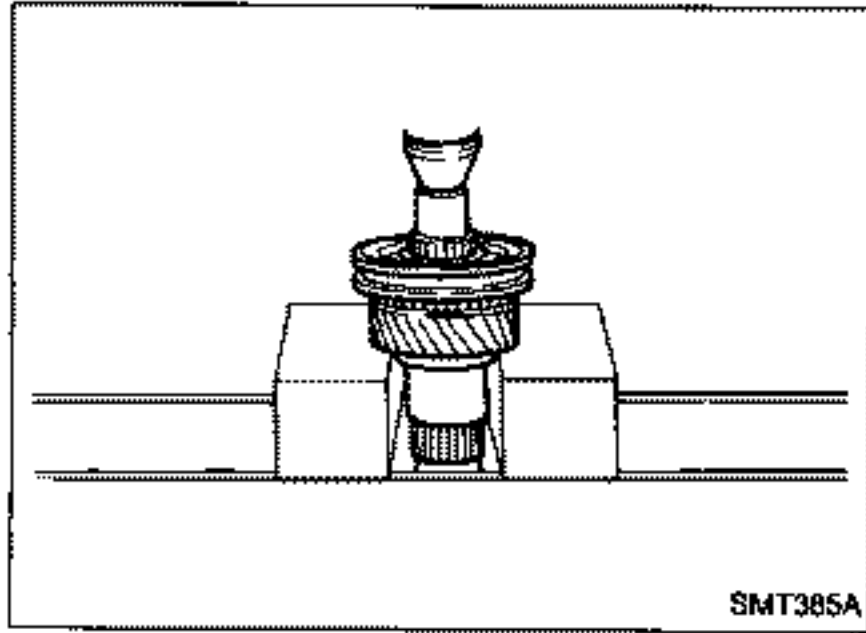

- e. Press out 3rd main gear together with 3rd & 4th synchronizer assembly and 3rd gear needle bearing.

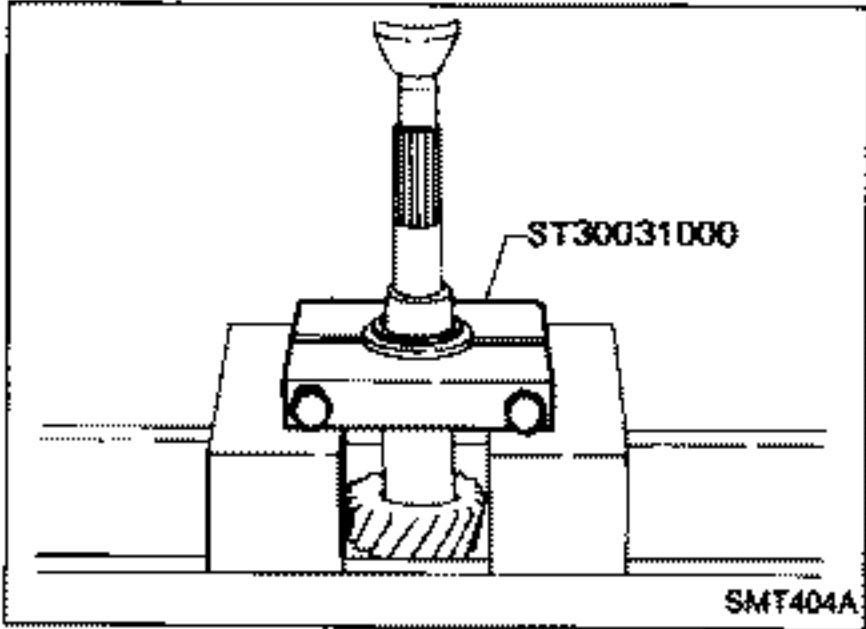

5. Remove front side components on counter gear.
  - a. Remove counter gear rear thrust bearing.

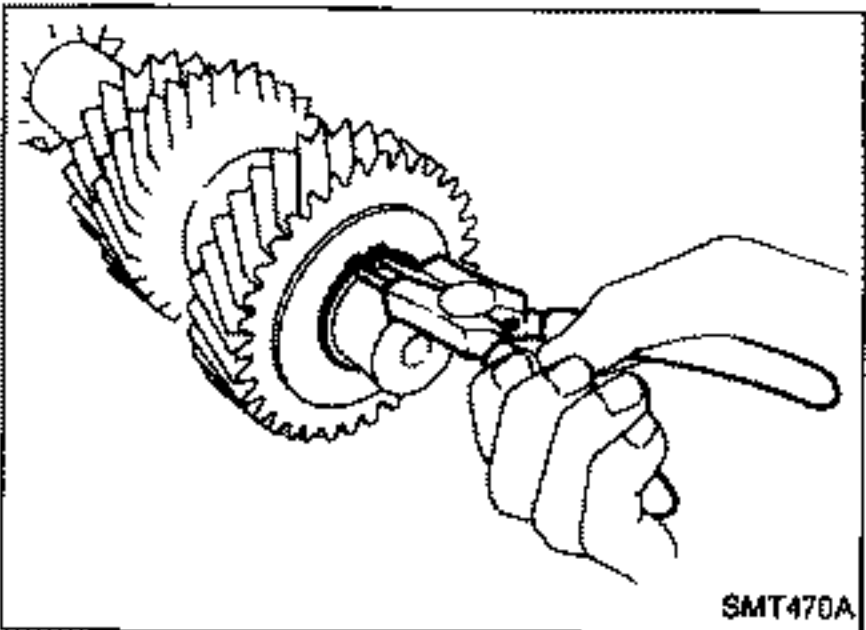

- b. Remove sub-gear components.

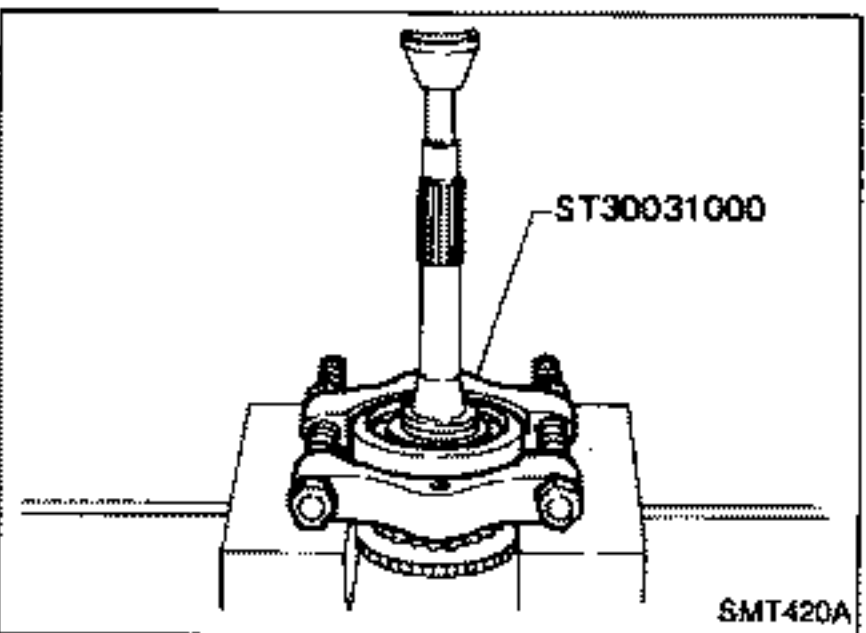

6. Remove main drive gear bearing.
  - a. Remove main drive gear snap ring and spacer.
  - b. Press out main drive gear bearing.

# DISASSEMBLY

## Gear Components (Cont'd)

7. Remove bearings from case components.

Counter gear front bearing in transmission case

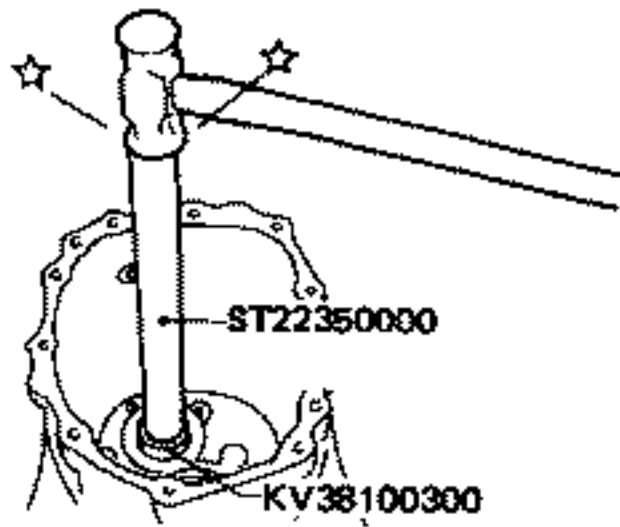

SMT388A

Mainshaft front bearing in adapter plate

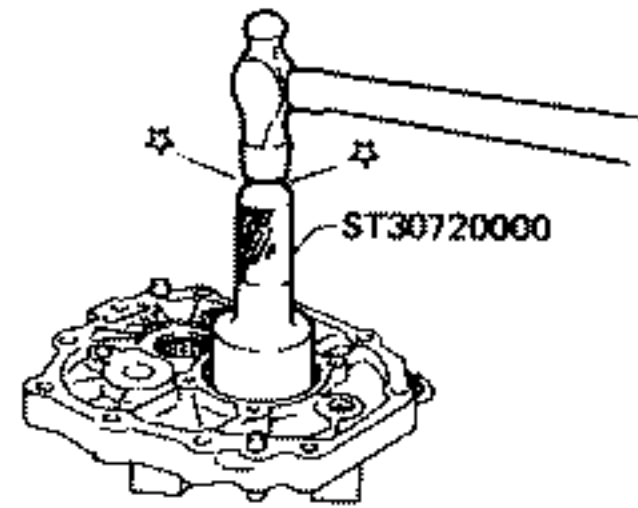

SMT395A

Counter gear rear bearing in adapter plate

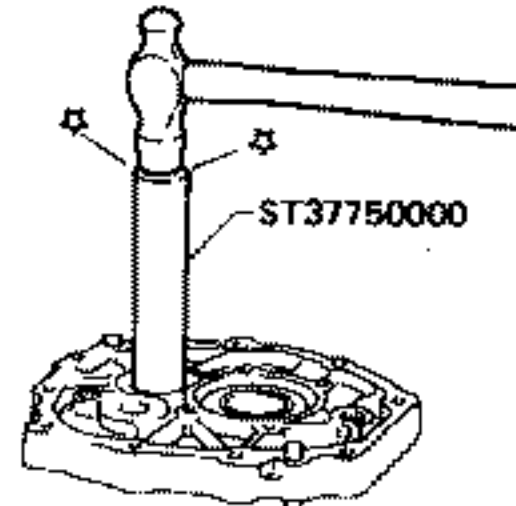

SMT394A

# INSPECTION

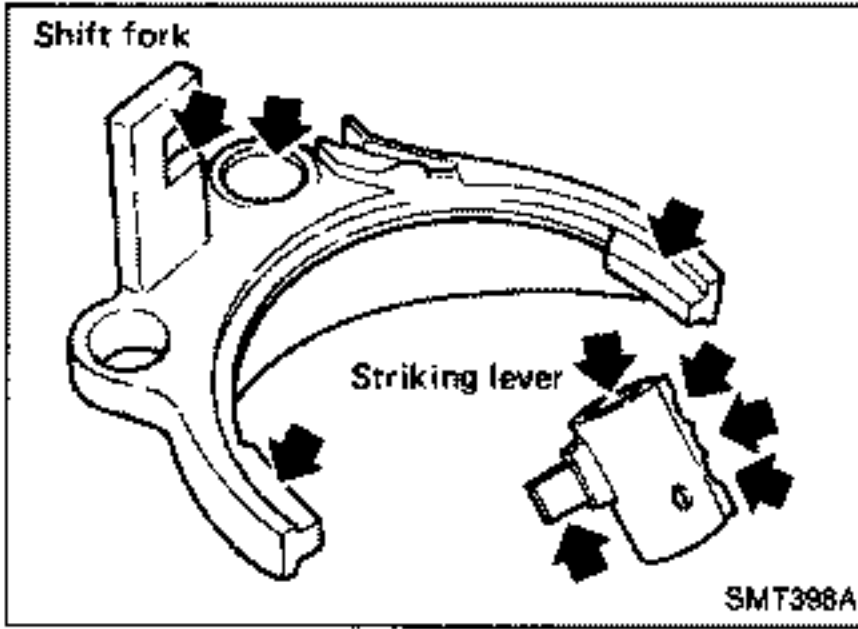

## Shift Control Components

- Check contact surface and sliding surface for wear, scratches, projections or other damage.

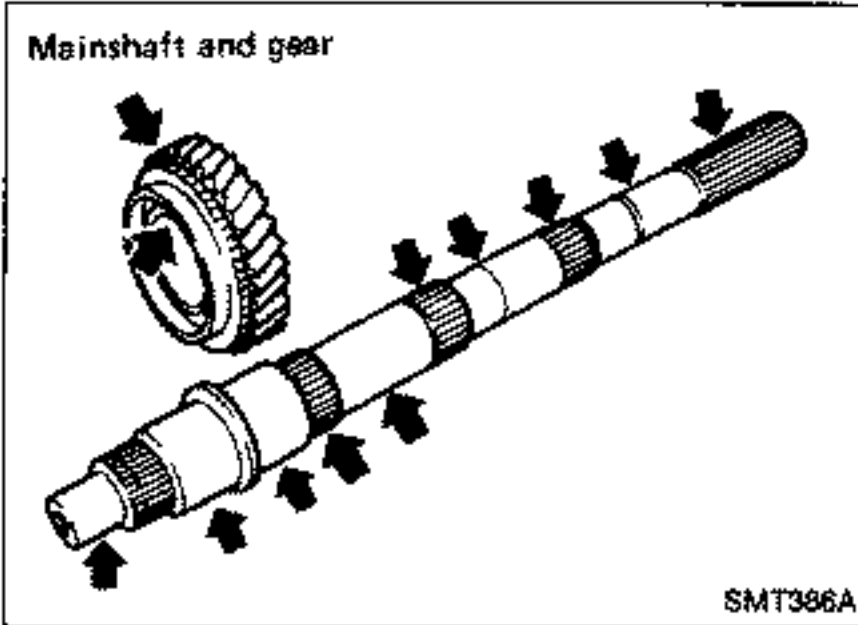

## Gear Components

### GEARS AND SHAFTS

- Check shafts for cracks, wear or bending.
- Check gears for excessive wear, chips or cracks.

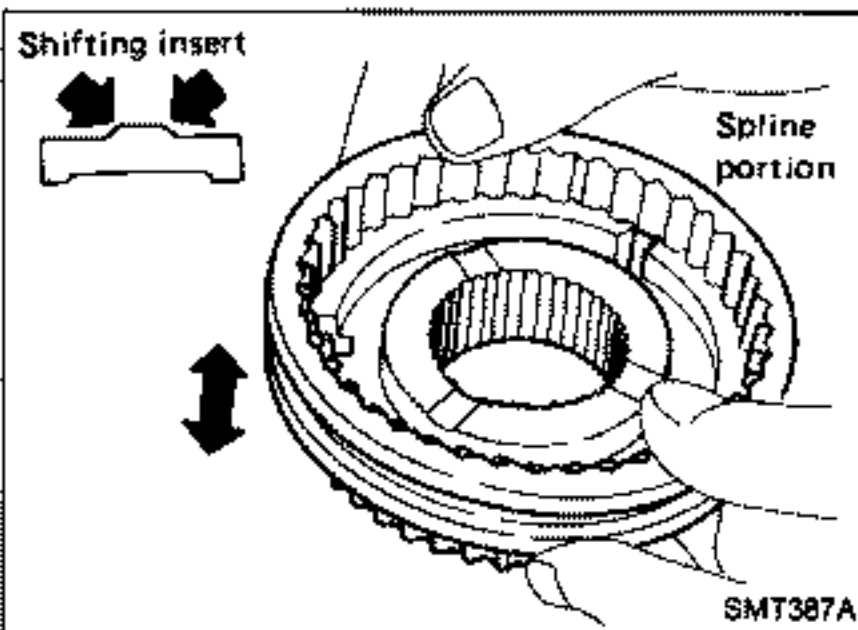
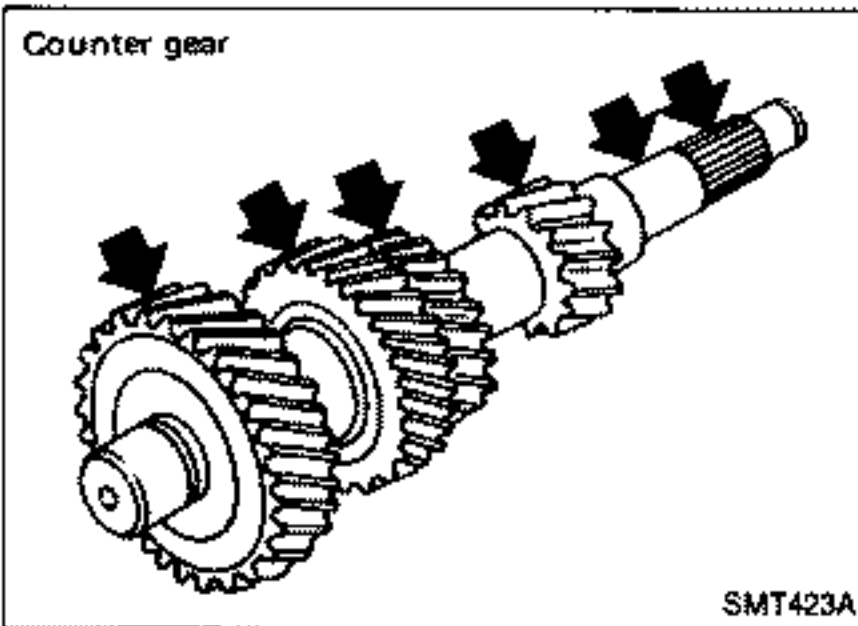

## SYNCHRONIZERS

- Check spline portion of coupling sleeves, hubs, and gears for wear or cracks.
- Check baulk rings for cracks or deformation.
- Check shifting inserts for wear or deformation.
- Check insert springs for deformation.

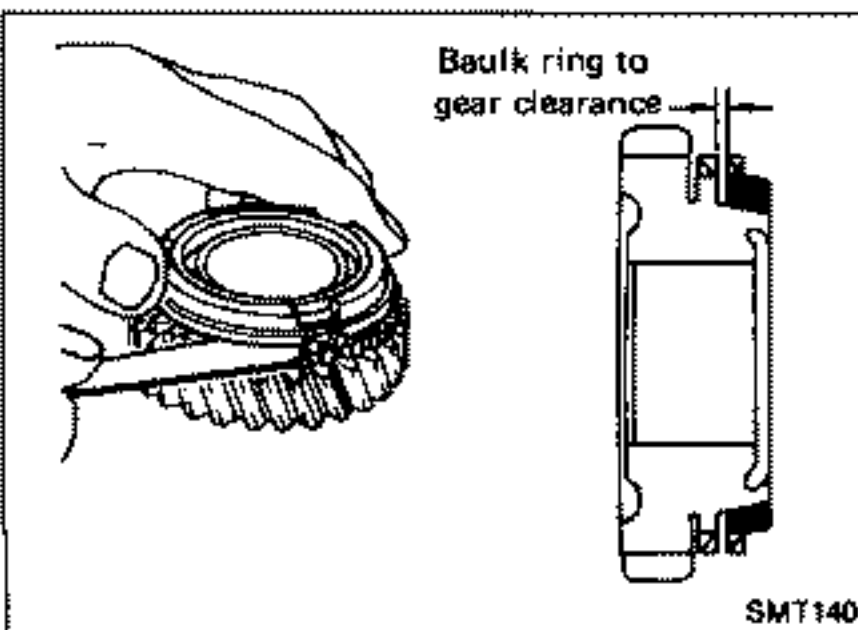

## Clearance between baulk ring and gear

- Measure wear of main drive, 1st and O.D. baulk rings.

	Standard	Wear limit
1st	1.05 - 1.3 (0.0413 - 0.0512)	0.7 (0.028)
Main drive	1.05 - 1.3 (0.0413 - 0.0512)	0.7 (0.028)
O.D.	1.05 - 1.3 (0.0413 - 0.0512)	0.7 (0.028)

If the clearance is smaller than the wear limit, replace baulk ring.

# INSPECTION

## Gear Components (Cont'd)

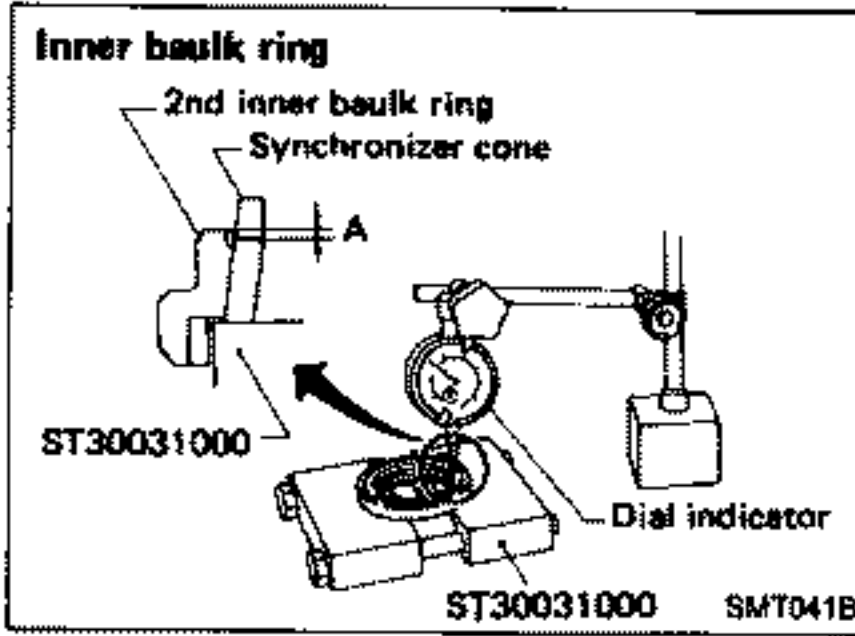

- Measure wear of 2nd and 3rd baulk rings.
- a. Place baulk rings in position on synchronizer cone.
- b. While holding baulk rings against synchronizer cone as far as it will go, measure dimensions "A" and "B".

Unit: mm (in)

Dimension	Standard	Wear limit
A	0.6 - 1.1 (0.024 - 0.043)	0.2 (0.008)
B	0.7 - 0.9 (0.028 - 0.035)	

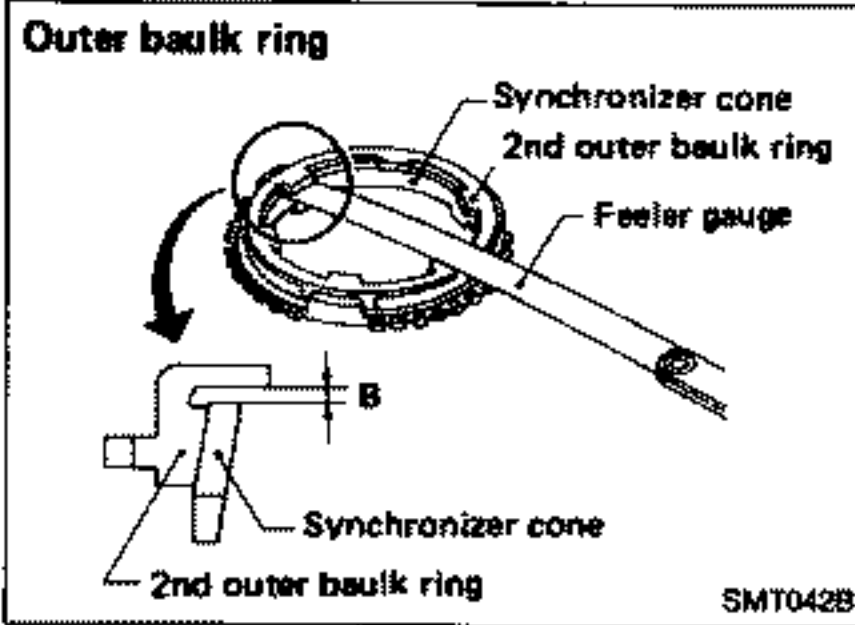

- c. If dimension "A" or "B" is smaller than the wear limit, replace baulk ring.

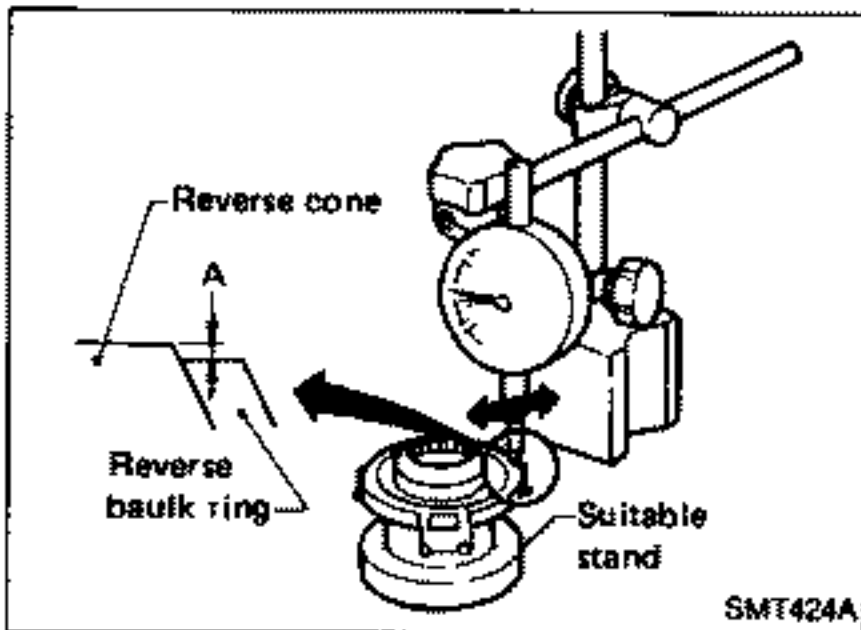

- Measure wear of reverse baulk ring.
- a. Place baulk ring in position on reverse cone.
- b. While holding baulk ring against reverse cone as far as it will go, measure dimension "A" with dial indicator.

Unit: mm (in)

	Standard	Wear limit
Dimension "A"	-0.1 to 0.35 (-0.0039 to 0.0138)	0.7 (0.028)

- c. If dimension "A" is larger than the wear limit, replace baulk ring.

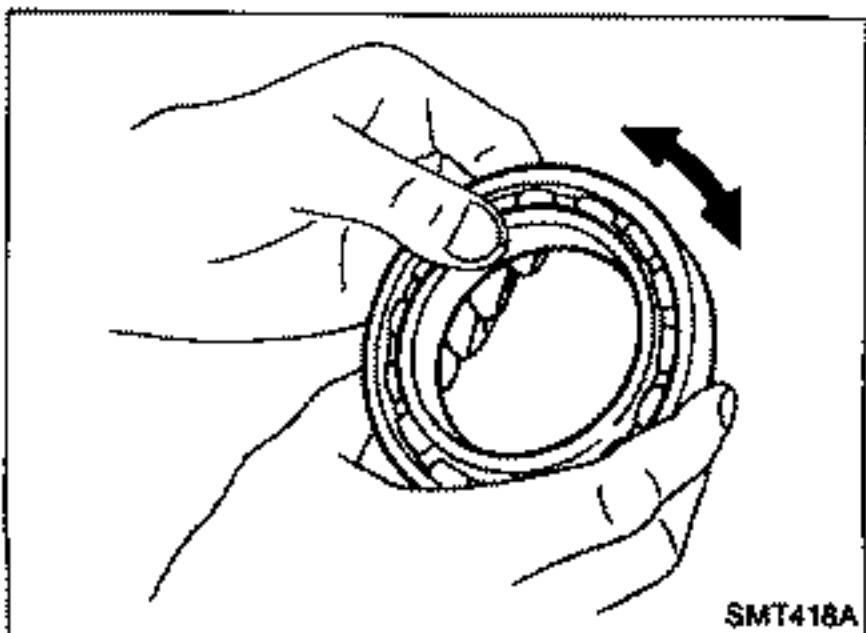

## BEARINGS

- Make sure bearings roll freely and are free from noise, crack, pitting or wear.

# ASSEMBLY

## Gear Components

1. Install bearings into case components.

Counter gear front bearing in transmission case

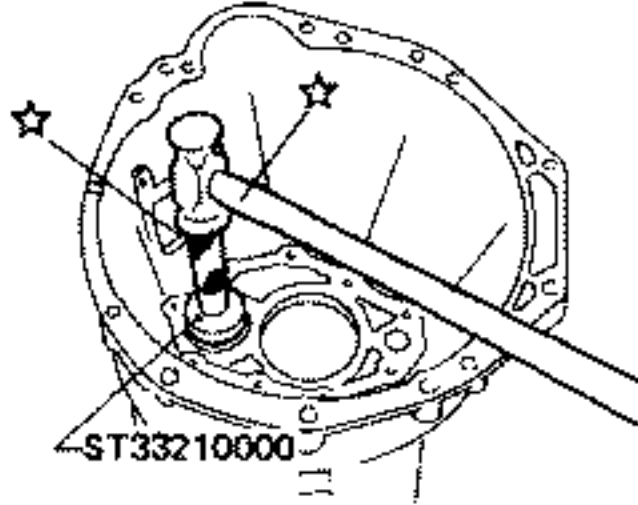

SMT389A

Mainshaft front bearing in adapter plate

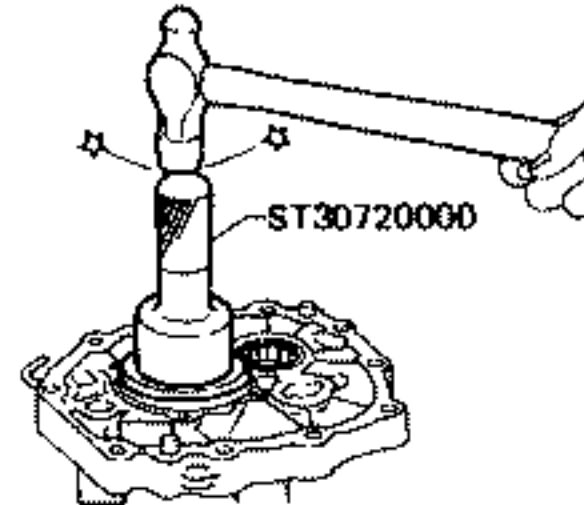

SMT397A

Counter gear rear bearing in adapter plate

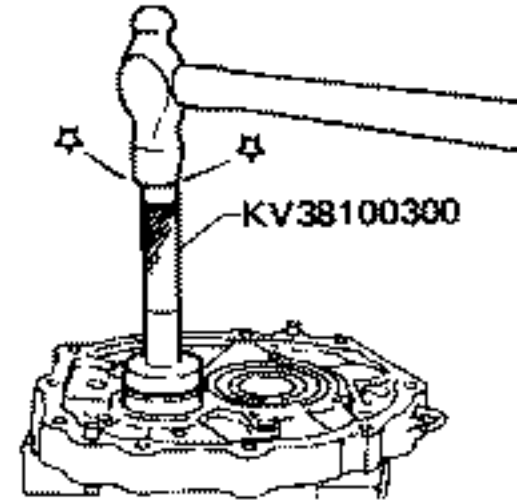

SMT395A

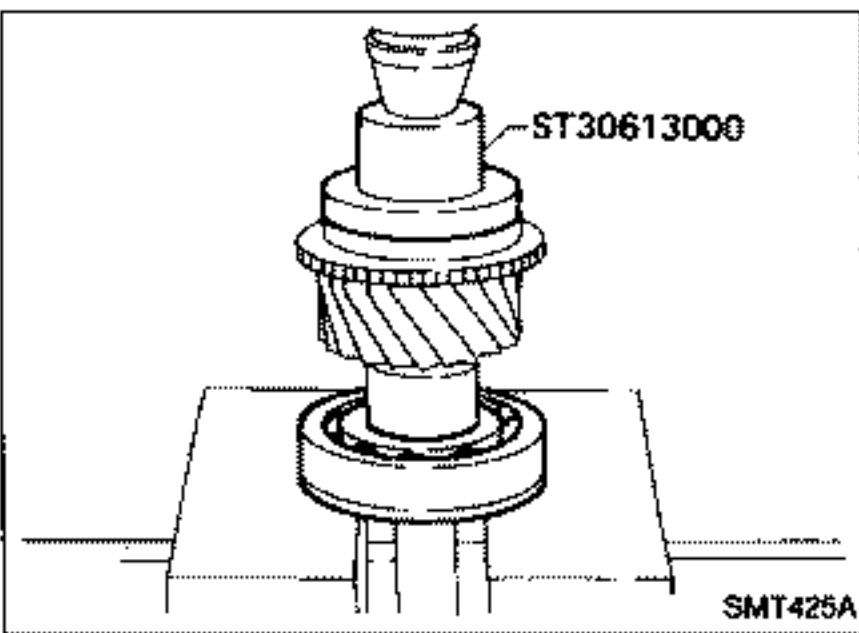

2. Install main drive gear bearing.
  - a. Press main drive gear bearing.
  - b. Install main drive gear spacer.

## ASSEMBLY

### Gear Components (Cont'd)

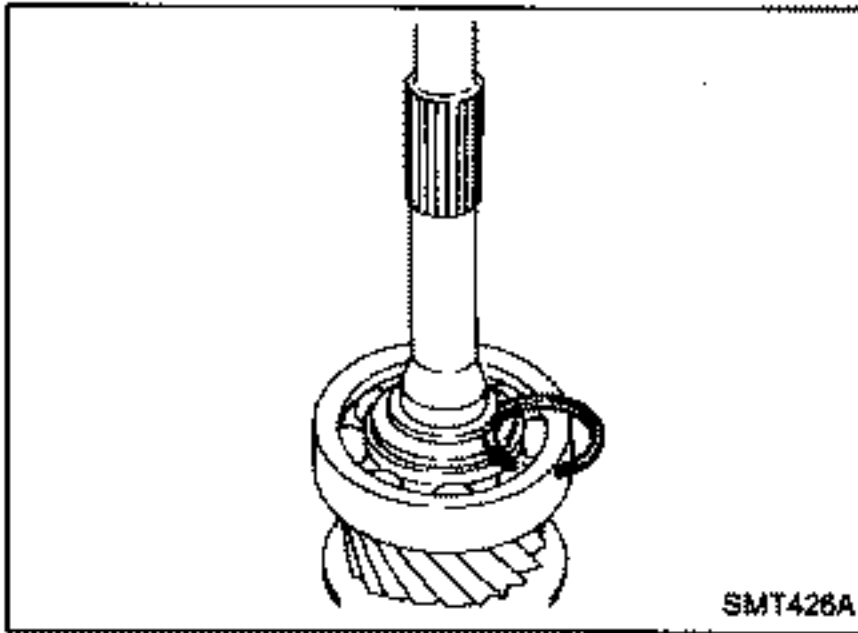

- c. Select proper main drive gear snap ring to minimize clearance of groove.

**Allowable clearance of groove:  
0 - 0.1 mm (0 - 0.004 in)**

#### Main drive gear snap ring

Thickness mm (in)	Part number
1.89 (0.0744)	32204-01G00
1.98 (0.0780)	32204-01G01
2.05 (0.0807)	32204-01G02
2.12 (0.0835)	32204-01G03
2.19 (0.0862)	32204-01G04

- d. Install selected snap ring on main drive gear.

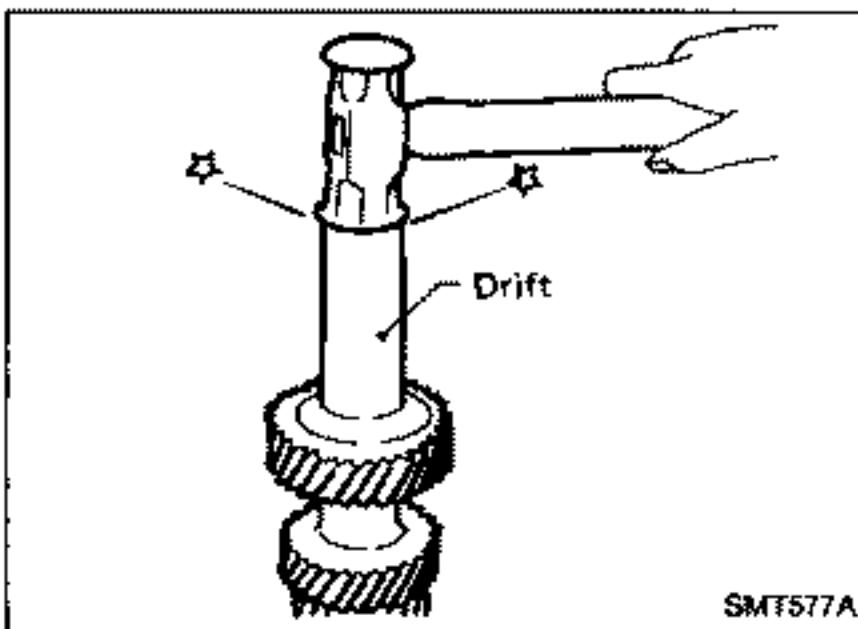

3. Install components on counter gear.

- a. Install sub-gear components.

**When installing sub-gear snap ring, tap sub-gear snap ring into position on counter gear.**

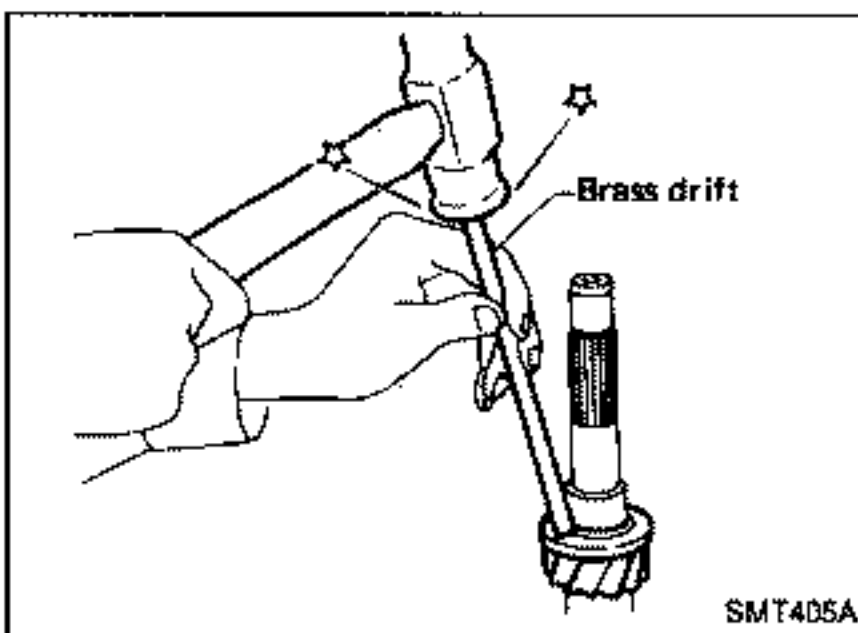

- b. Install counter gear rear thrust bearing.

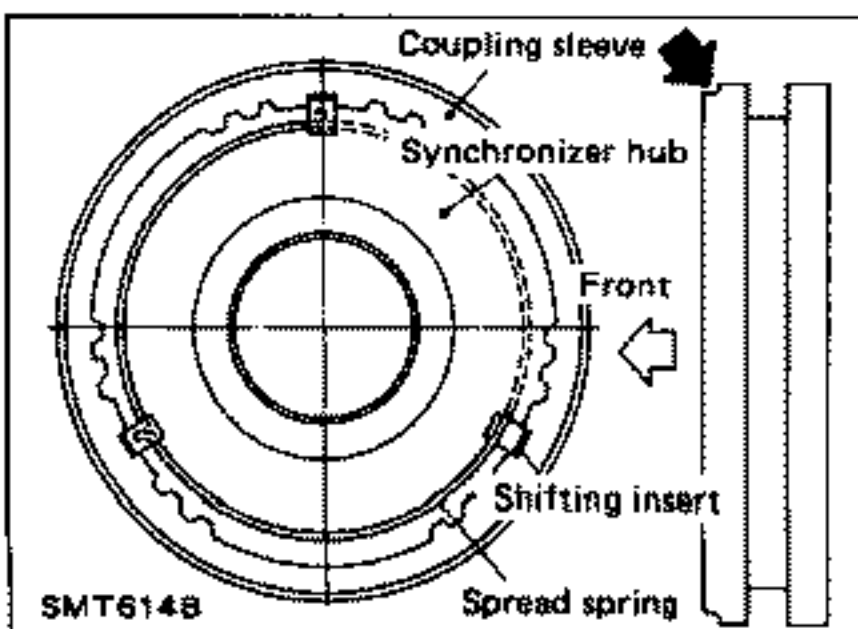

4. Install front side components on mainshaft.

- a. Assemble 1st & 2nd synchronizer.

## ASSEMBLY

### Gear Components (Cont'd)

b. Assemble 3rd & 4th synchronizer.

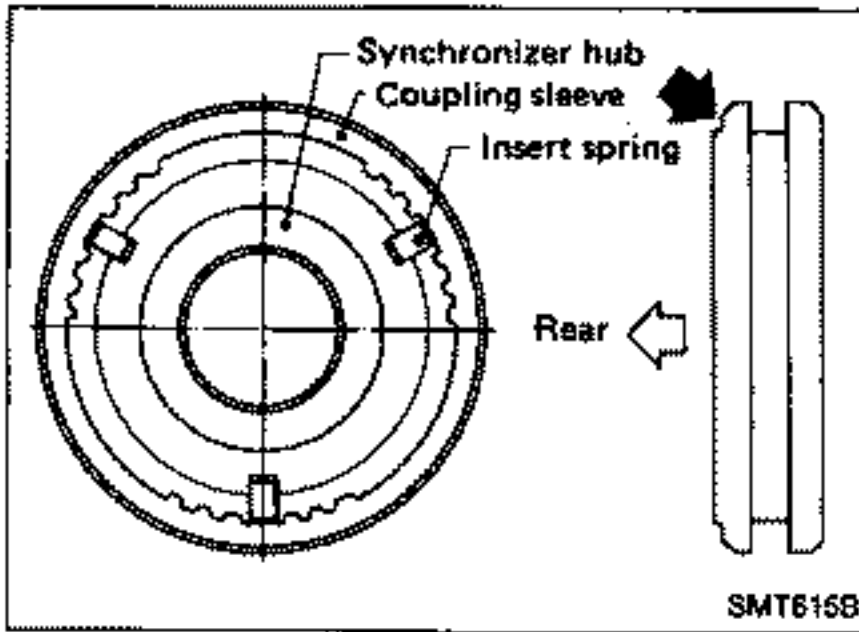

c. Press on 3rd & 4th synchronizer assembly together with 3rd main gear and 3rd gear needle bearing.

**Pay attention to direction of synchronizer assembly.**

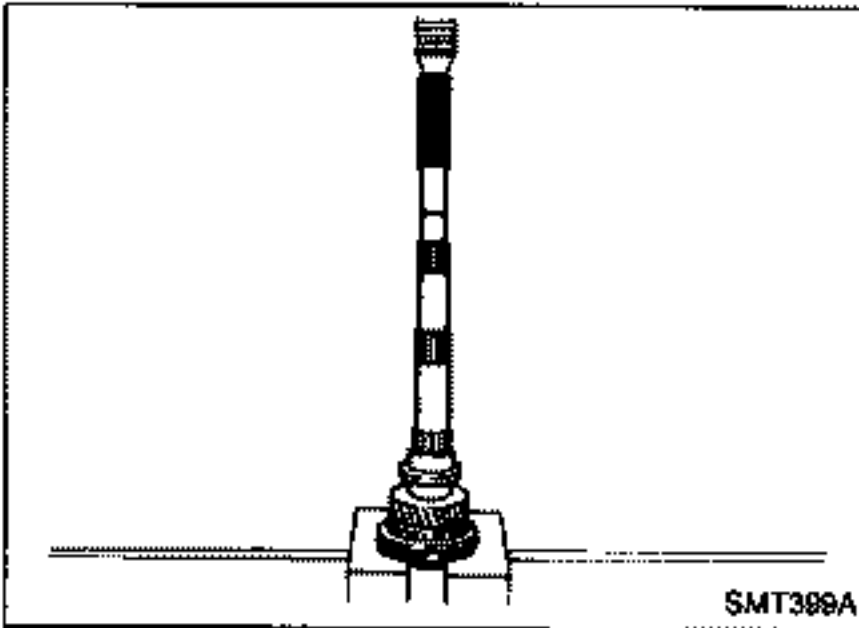

d. Select proper snap ring to minimize clearance of groove.

**Allowable clearance of groove:**

**0 - 0.1 mm (0 - 0.004 in)**

**Mainshaft front snap ring**

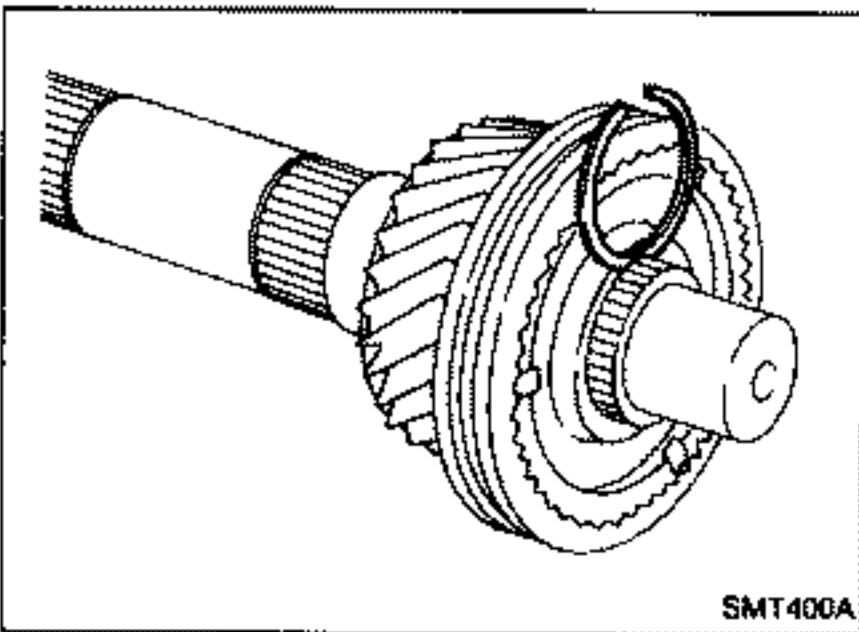

Thickness mm (in)	part number
1.89 (0.0744)	32204-01G00
1.98 (0.0780)	32204-01G01
2.05 (0.0807)	32204-01G02
2.12 (0.0835)	32204-01G03
2.19 (0.0862)	32204-01G04

e. Install selected snap ring on mainshaft.

f. Press on 1st & 2nd synchronizer assembly together with 2nd main gear and 2nd gear needle bearing.

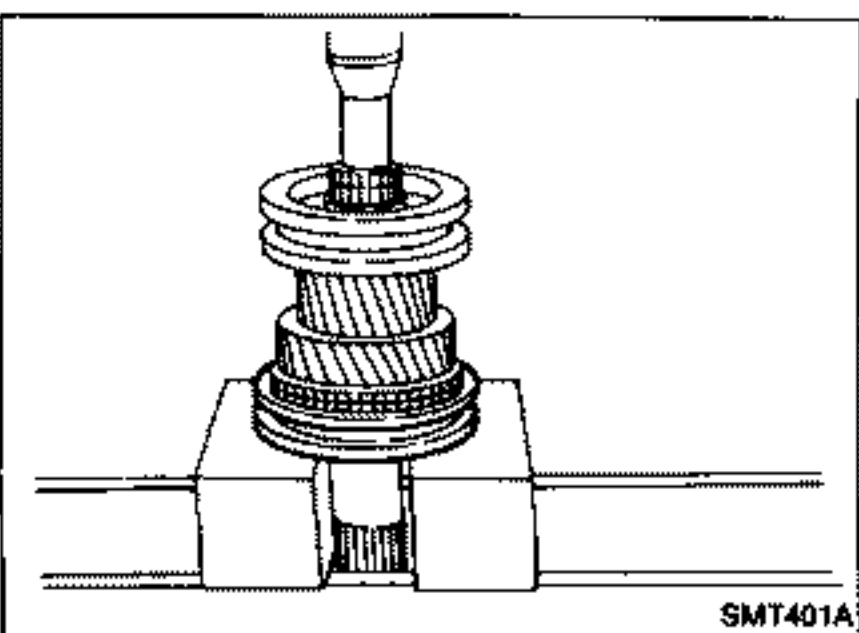



## ASSEMBLY

### Gear Components (Cont'd)

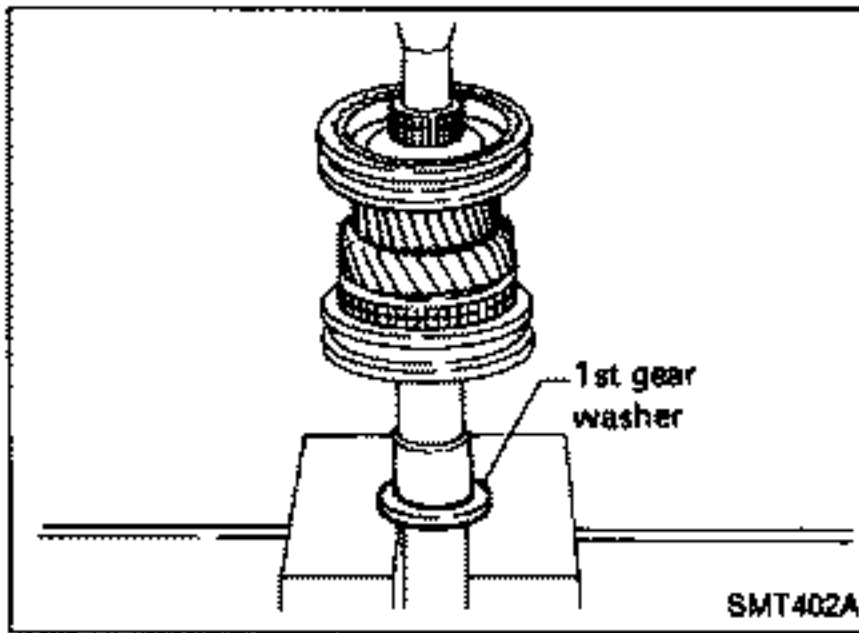

- g. Press on 1st gear bushing using 1st gear washer.
- h. Install 1st main gear and needle bearing.

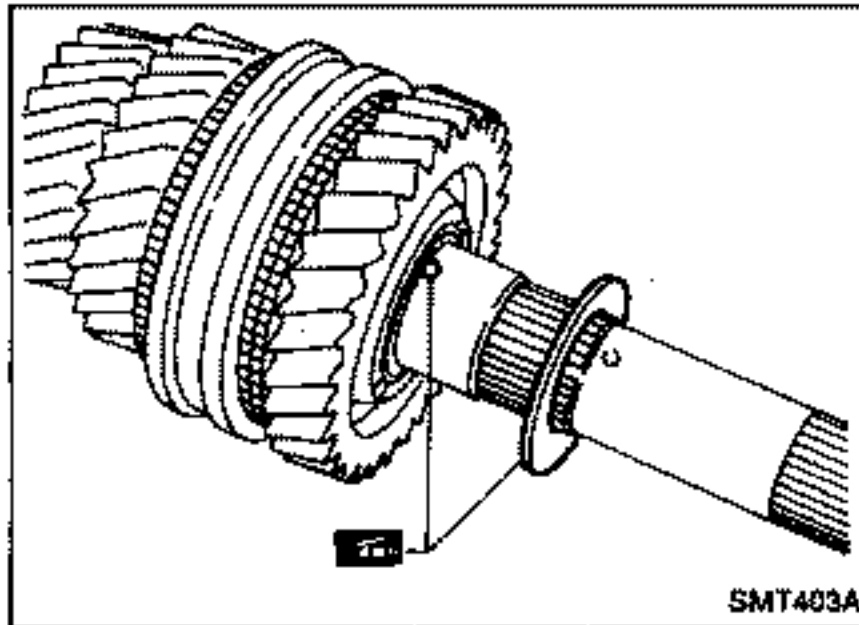

- i. Install steel ball and 1st gear washer.  
**Apply multi-purpose grease to steel ball and 1st gear washer before installing.**

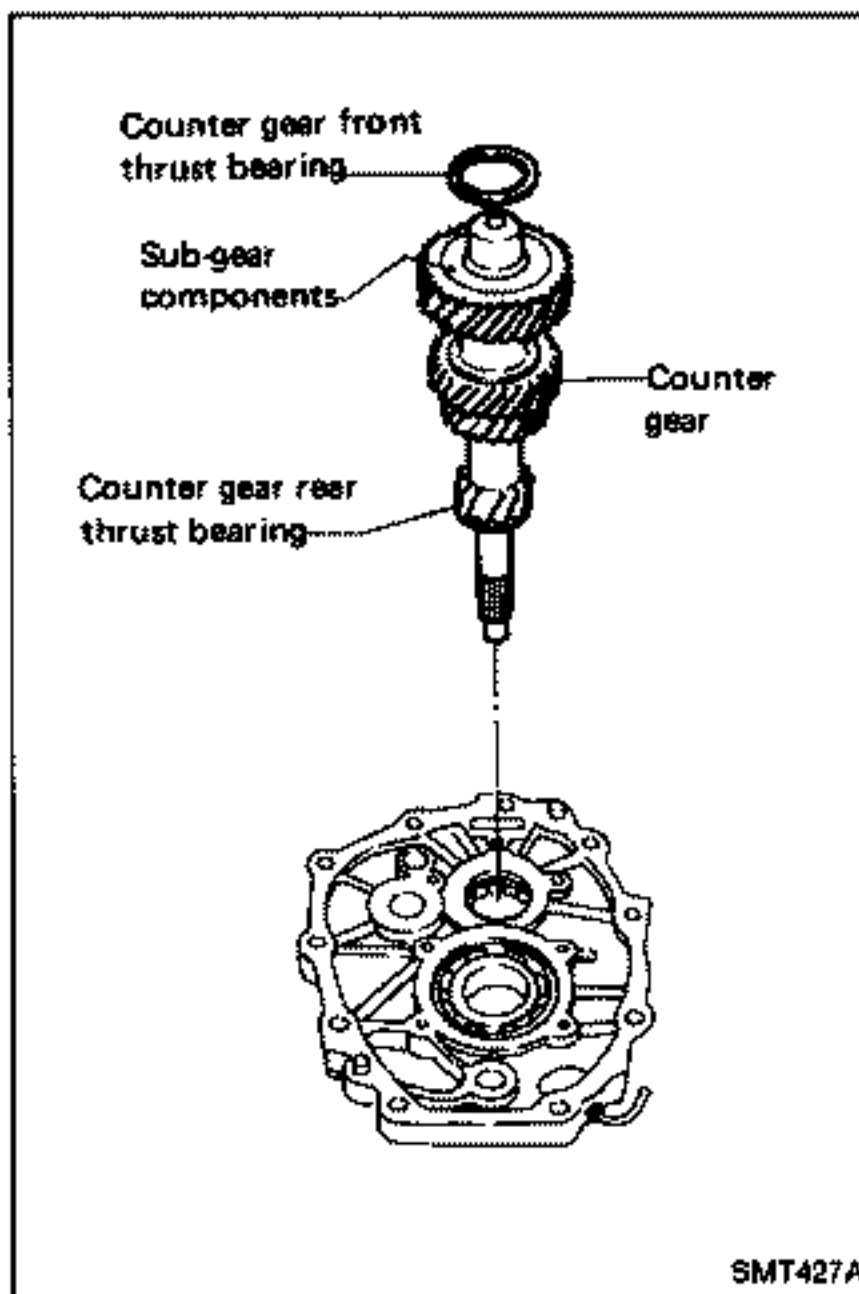

- 5. Select proper counter gear front bearing shim when replacing transmission case, counter gear, counter gear thrust bearing or sub-gear components.
  - a. Install counter gear with sub-gear components, counter gear front and rear thrust bearing on adapter plate.
  - b. Remove counter gear front bearing shim from transmission case.
  - c. Place adapter plate and counter gear assembly in transmission case (case inverted).

## ASSEMBLY

### Gear Components (Cont'd)

- d. Tighten adapter plate to transmission case using 2 bolts.
- e. Place dial indicator on rear end of counter gear.
- f. Move counter gear up and down and measure dial indicator deflection.
- g. Select proper shim using table below as a guide.

**Counter gear end play:**

**0.10 - 0.25 mm (0.0039 - 0.0098 in)**

**Table for selecting proper counter gear front bearing shim**

Dial indicator deflection mm (in)	Thickness of proper washer mm (in)	Part number
0.93 - 1.02 (0.0366 - 0.0402)	0.8 (0.031)	32218-01G00
1.03 - 1.12 (0.0406 - 0.0441)	0.9 (0.035)	32218-01G01
1.13 - 1.22 (0.0445 - 0.0480)	1.0 (0.039)	32218-01G02
1.23 - 1.32 (0.0484 - 0.0520)	1.1 (0.043)	32218-01G03
1.33 - 1.42 (0.0524 - 0.0559)	1.2 (0.047)	32218-01G04
1.43 - 1.52 (0.0563 - 0.0598)	1.3 (0.051)	32218-01G05
1.53 - 1.62 (0.0602 - 0.0638)	1.4 (0.055)	32218-01G06

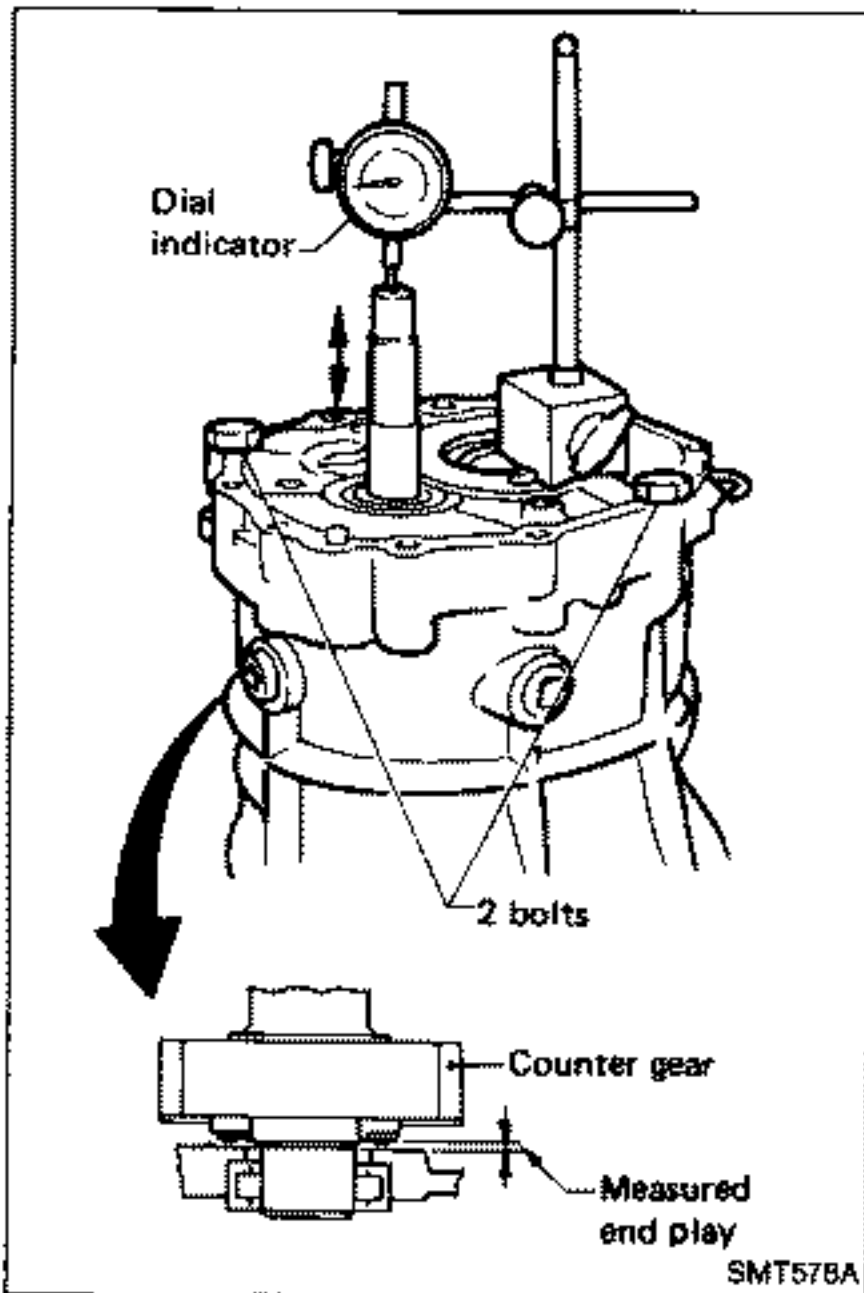

6. Select proper reverse idler rear thrust washer when replacing rear extension, reverse idler gear, reverse idler shaft or reverse idler thrust washer.
  - a. Install reverse idler gear, reverse idler needle bearings, reverse idler thrust washers and reverse idler shaft into rear extension.

**When replacing reverse idler rear washer, install either A or B.**

#### Reverse idler rear thrust washer

	Thickness mm (in)	Part number
A	1.97 (0.0776)	32284-01G10
B	2.07 (0.0815)	32284-01G11

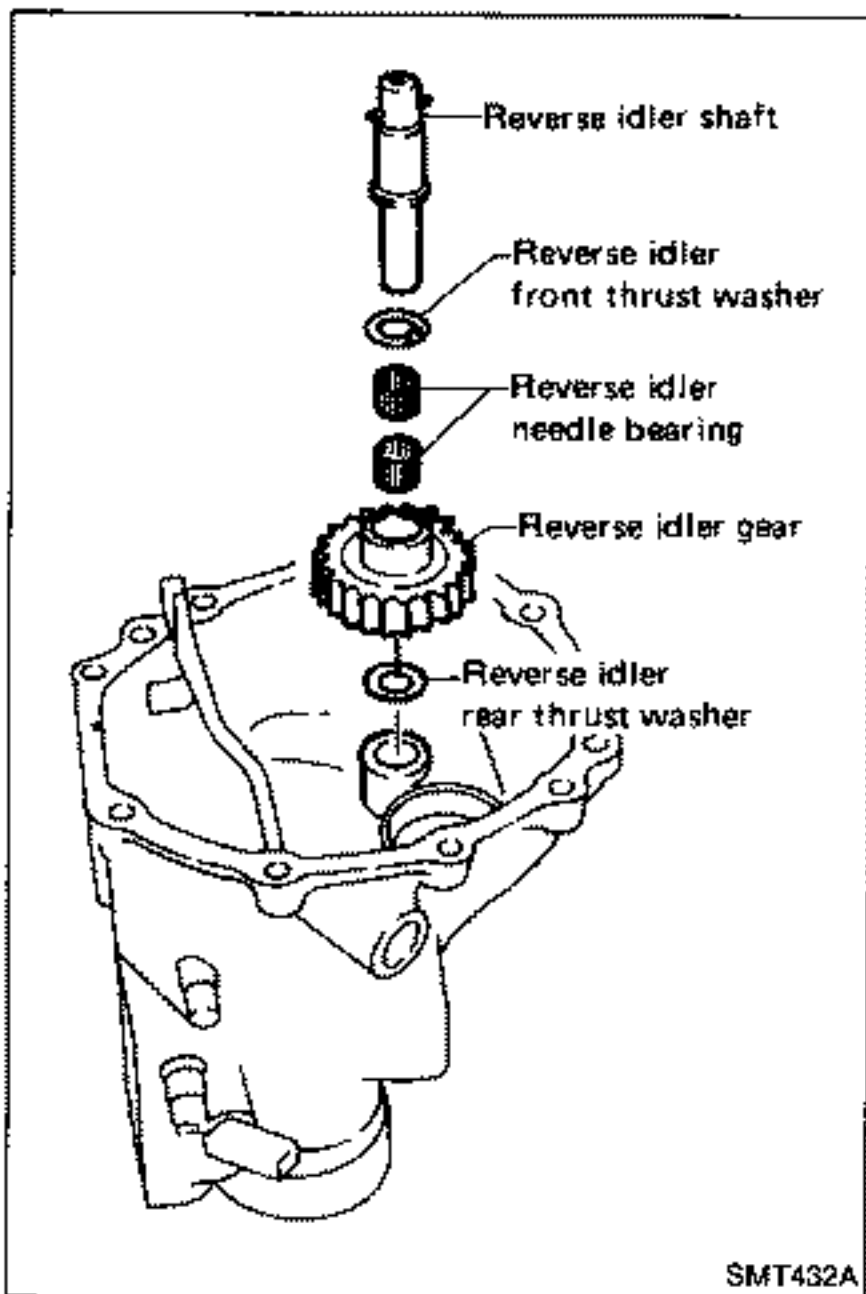

## ASSEMBLY

### Gear Components (Cont'd)

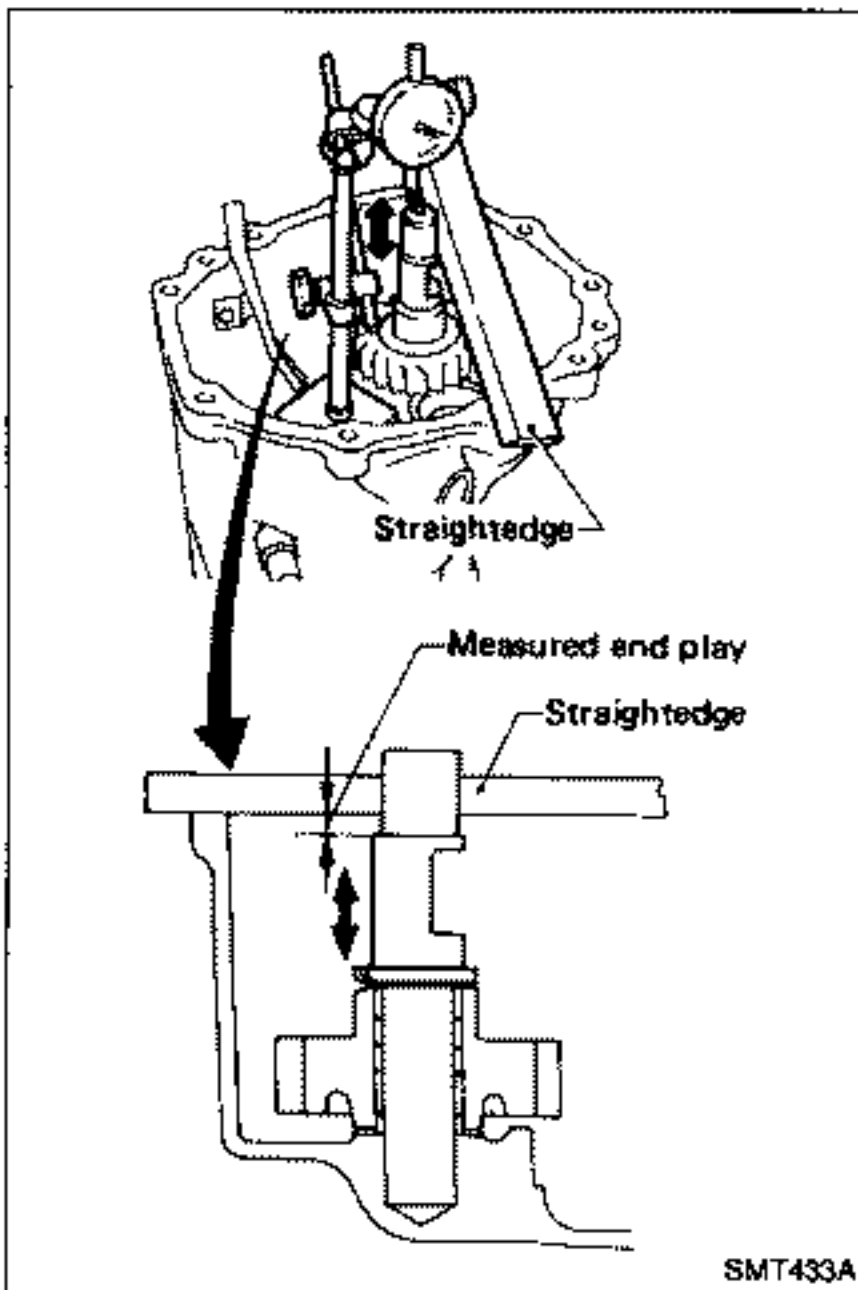

- b. Place dial indicator on front end of reverse idler shaft.
- c. Put straightedge on front surface of rear extension as a stopper of reverse idler shaft.
- d. Move reverse idler shaft up and down and measure reverse idler gear end play.

#### Reverse idler gear end play:

0.30 - 0.53 mm (0.0118 - 0.0209 in)

- e. If not within specification, replace reverse idler rear thrust washer with the other (A or B) and check again.

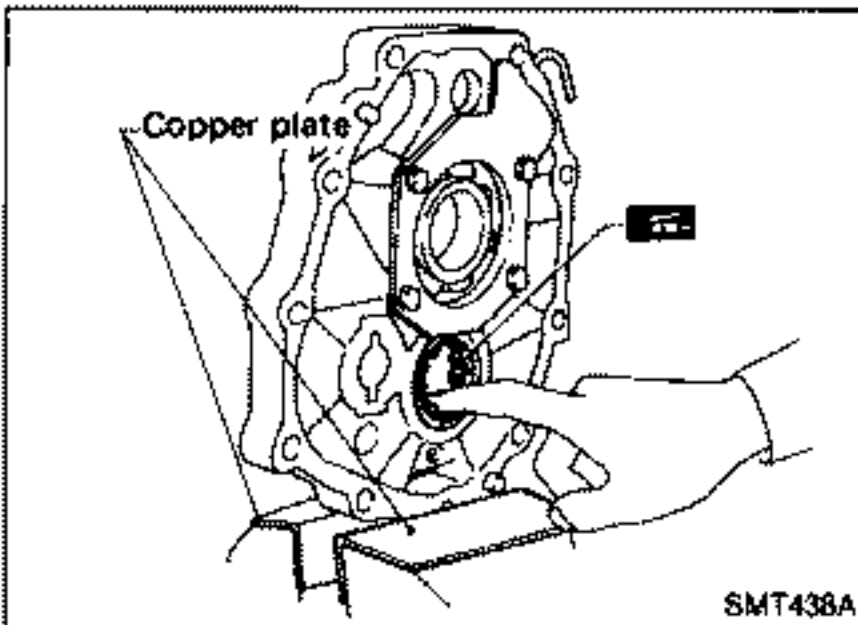

7. Install mainshaft and counter gear on adapter plate and main drive gear on mainshaft.
  - a. Mount adapter plate on vise and apply multi-purpose grease to counter gear rear bearing.

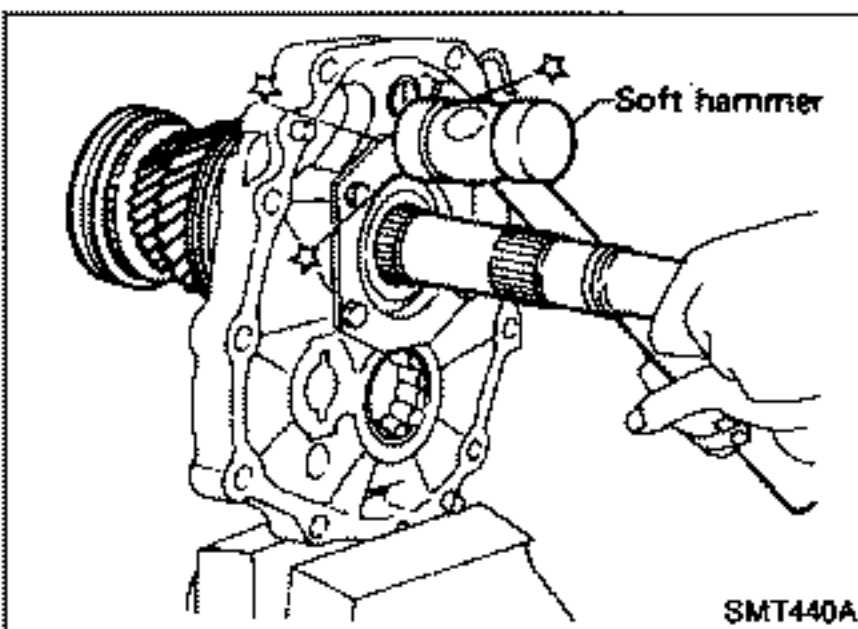

- b. Install mainshaft a little on mainshaft front bearing.  
**To allow for installation of counter gear, do not install mainshaft completely.**

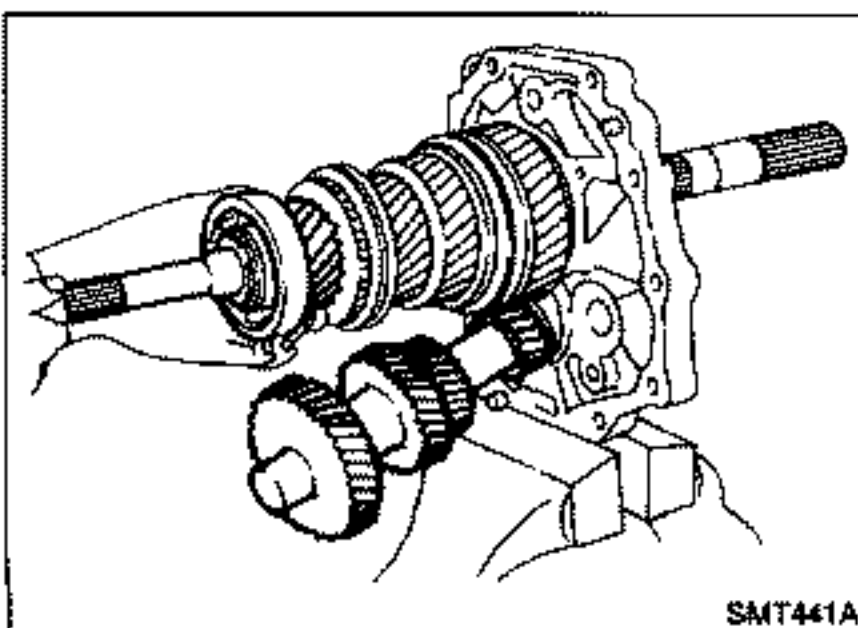

- c. Install counter gear on counter gear rear bearing and install main drive gear, pilot bearing and spacer on mainshaft.

## ASSEMBLY

### Gear Components (Cont'd)

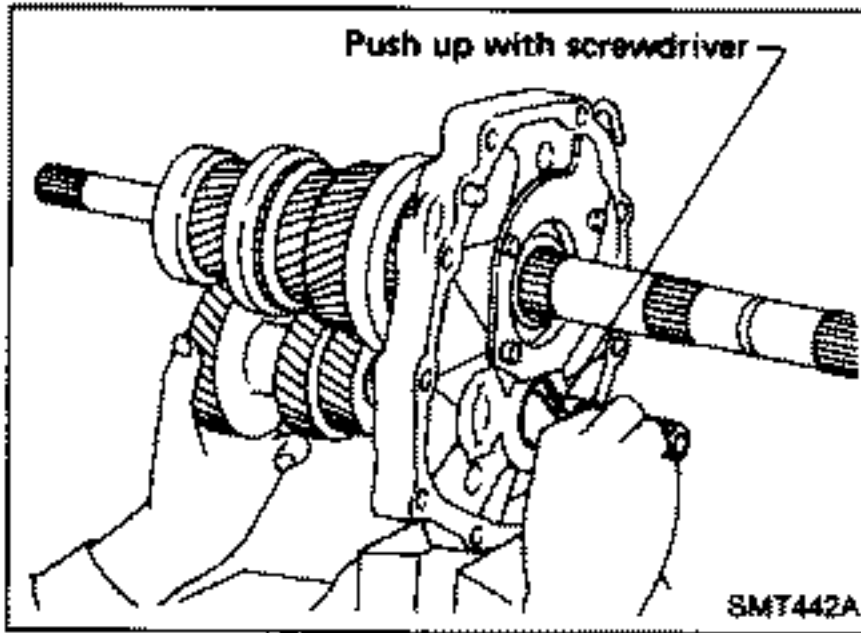

When installing counter gear into counter gear rear bearing, push up on upper roller of counter gear rear bearing with screwdriver.

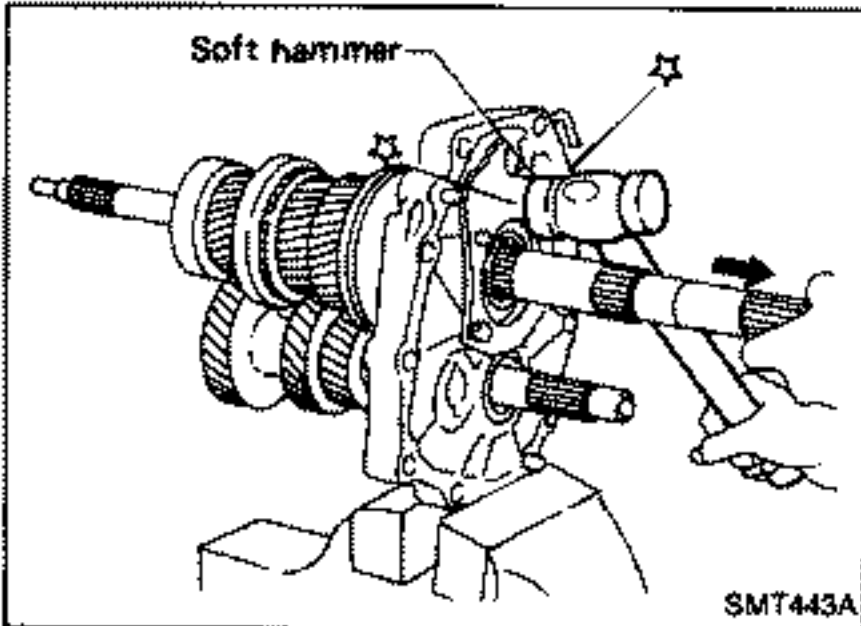

d. Install mainshaft and counter gear completely by tapping rear side of adapter plate and pulling mainshaft.

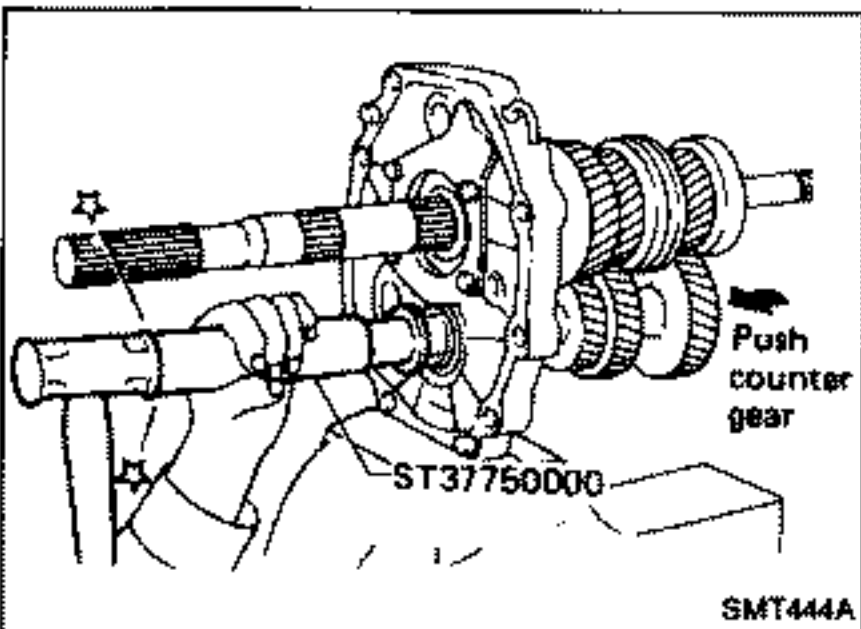

8. Install rear side components on mainshaft and counter gear.

a. Install O.D. gear bushing while pushing on the front of counter gear.

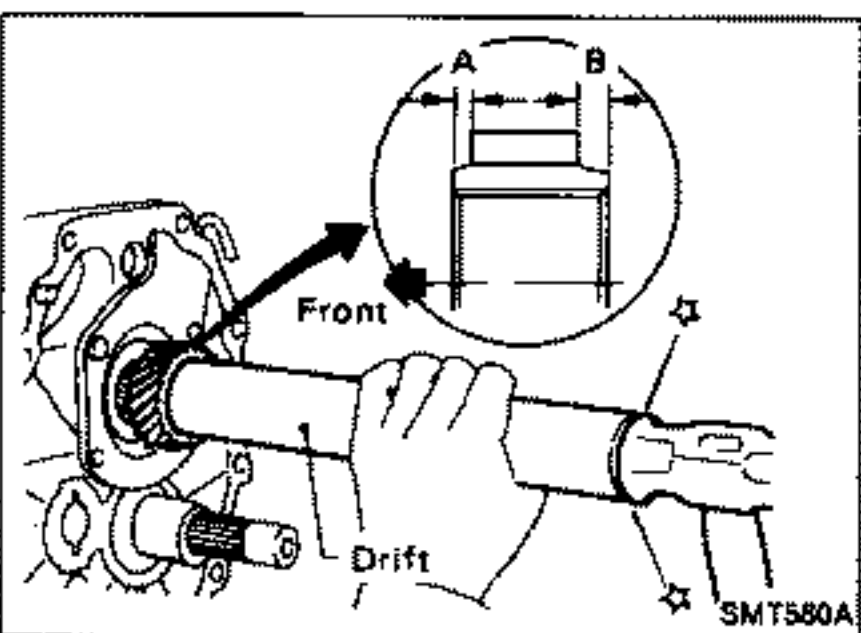

b. Install O.D. main gear.

**Pay attention to direction of O.D. main gear. (B is wider than A as shown at left.)**

c. Install adapter plate with gear assembly onto transmission case.

d. Install O.D. gear needle bearing and then install O.D. counter gear and reverse idler shaft.

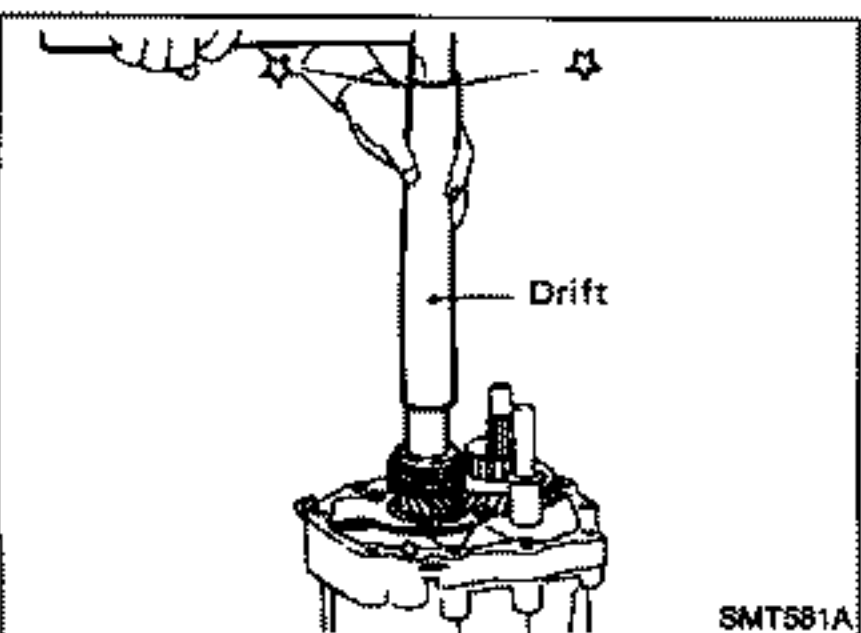

e. Install reverse gear bushing.

## ASSEMBLY

### Gear Components (Cont'd)

f. Install reverse cone.

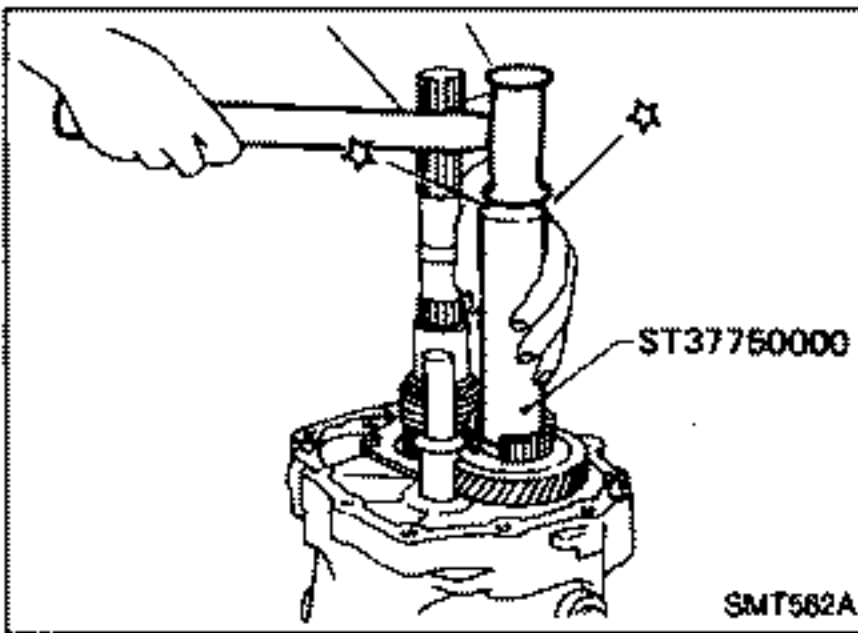

g. Install insert springs and reverse baulk ring on O.D. coupling sleeve. Then install them and O.D. baulk ring on O.D. counter gear.

**Pay attention to direction of O.D. coupling sleeve.**

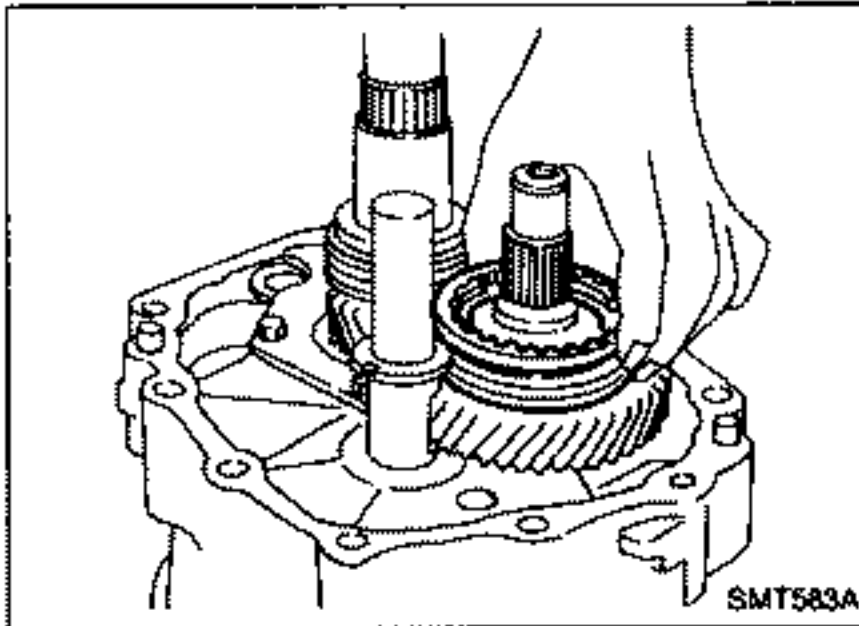
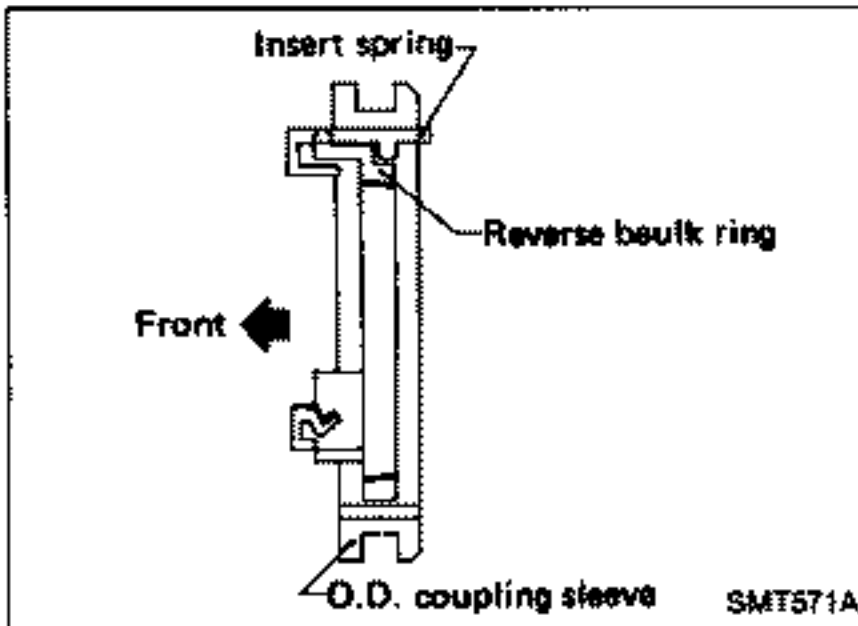

h. Install reverse counter gear.

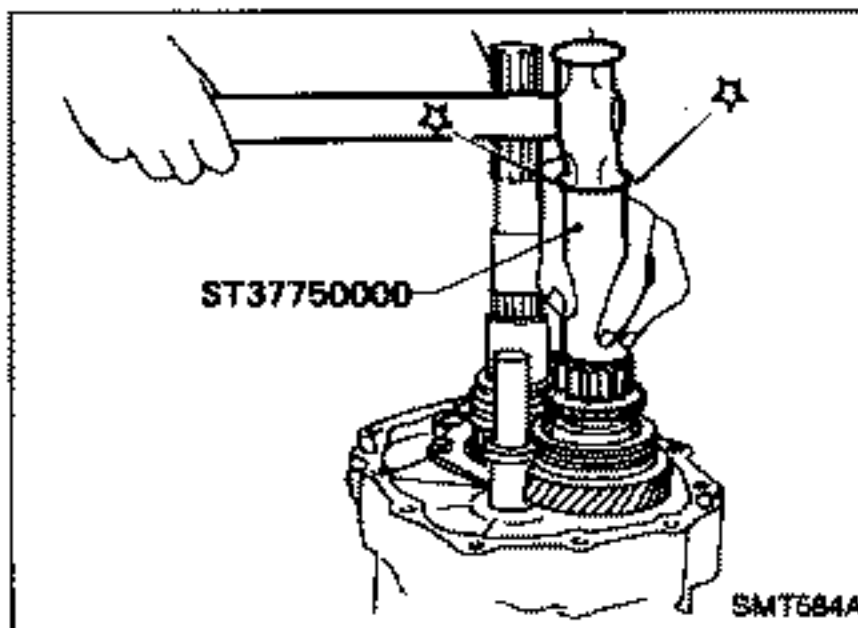

i. Install sub-gear on reverse idler gear.

j. Install reverse gear needle bearing and then install reverse main gear, reverse idler gear and reverse idler thrust washers.

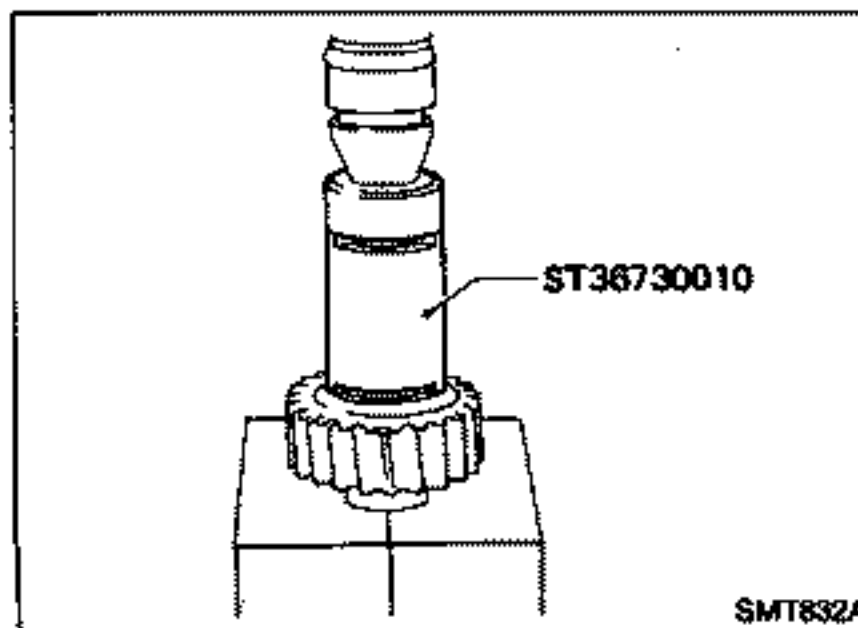

# ASSEMBLY

## Gear Components (Cont'd)

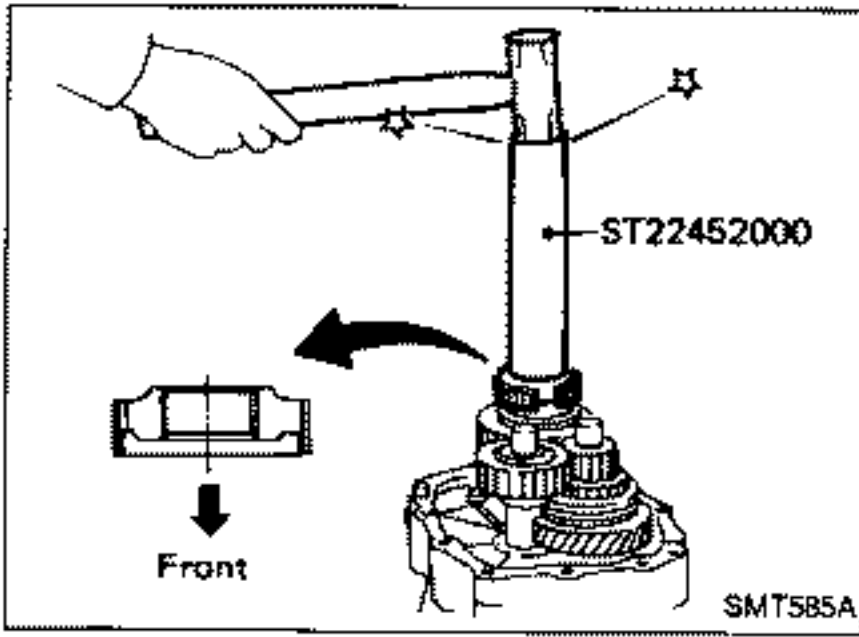

- k. Install reverse hub.  
Pay attention to its direction.

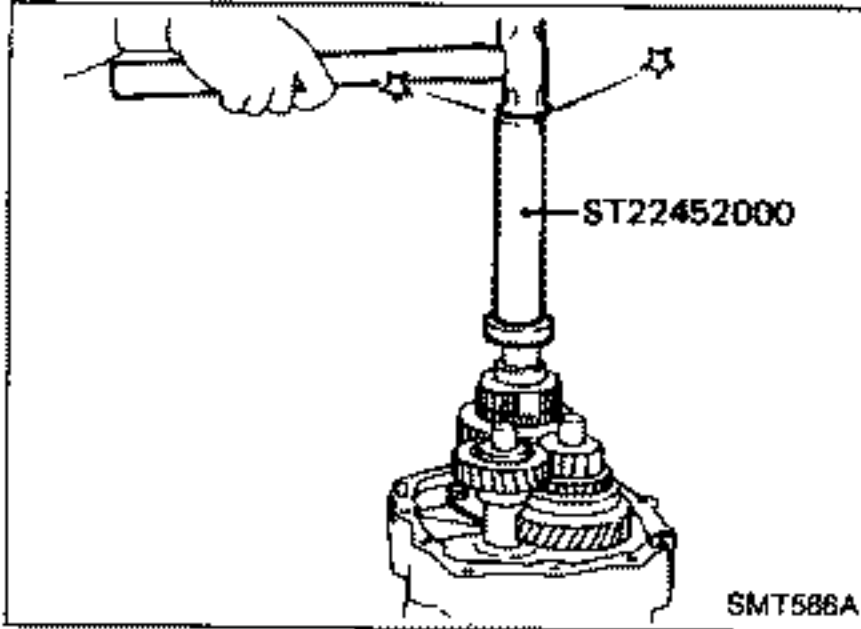

- l. Install mainshaft spacer and mainshaft rear bearing.
- m. Install speedometer drive gear.

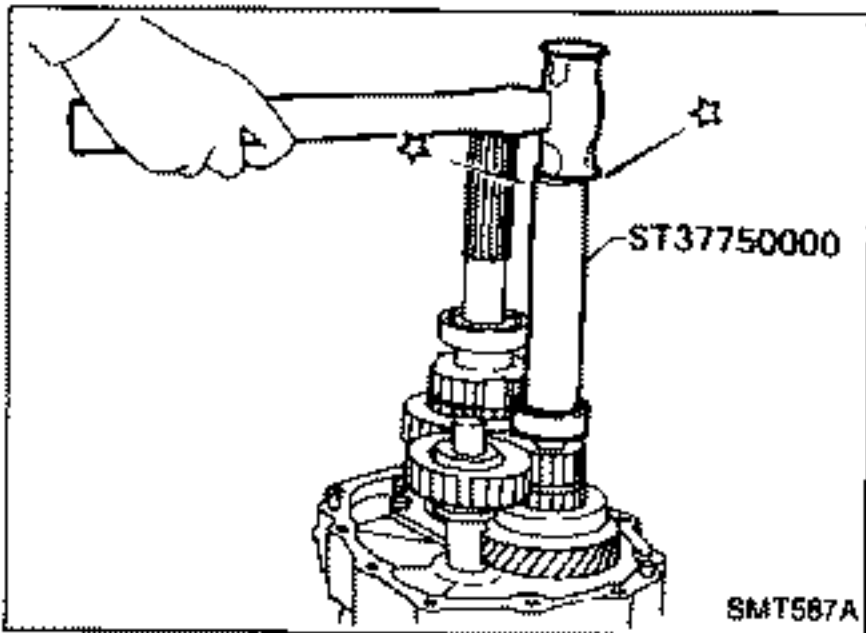

- n. Install counter gear rear end bearing.
- o. Separate adapter plate from transmission case and mount adapter plate on vise again.

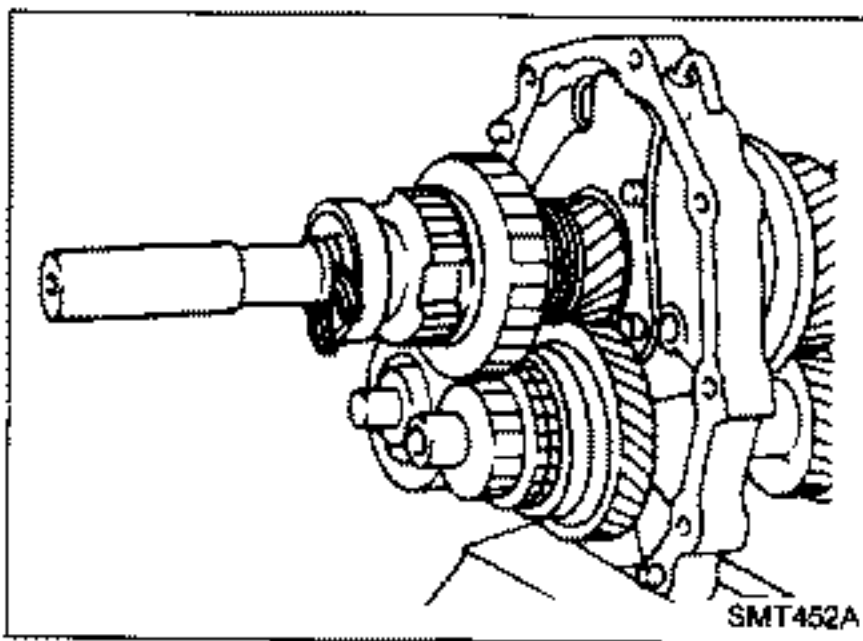

- p. Select proper mainshaft C-ring to minimize clearance of groove.

Allowable clearance of groove:

0 - 0.1 mm (0 - 0.004 in)

### Mainshaft C-ring

Thickness mm (in)	Part number	Thickness mm (in)	Part number
2.63 (0.1035)	32348-01G15	3.19 (0.1256)	32348-01G07
2.70 (0.1063)	32348-01G00	3.26 (0.1283)	32348-01G08
2.77 (0.1091)	32348-01G01	3.33 (0.1311)	32348-01G09
2.84 (0.1118)	32348-01G02	3.40 (0.1339)	32348-01G10
2.91 (0.1146)	32348-01G03	3.47 (0.1366)	32348-01G11
2.98 (0.1173)	32348-01G04	3.54 (0.1394)	32348-01G12
3.05 (0.1201)	32348-01G05	3.61 (0.1421)	32348-01G13
3.12 (0.1228)	32348-01G06	3.68 (0.1449)	32348-01G14

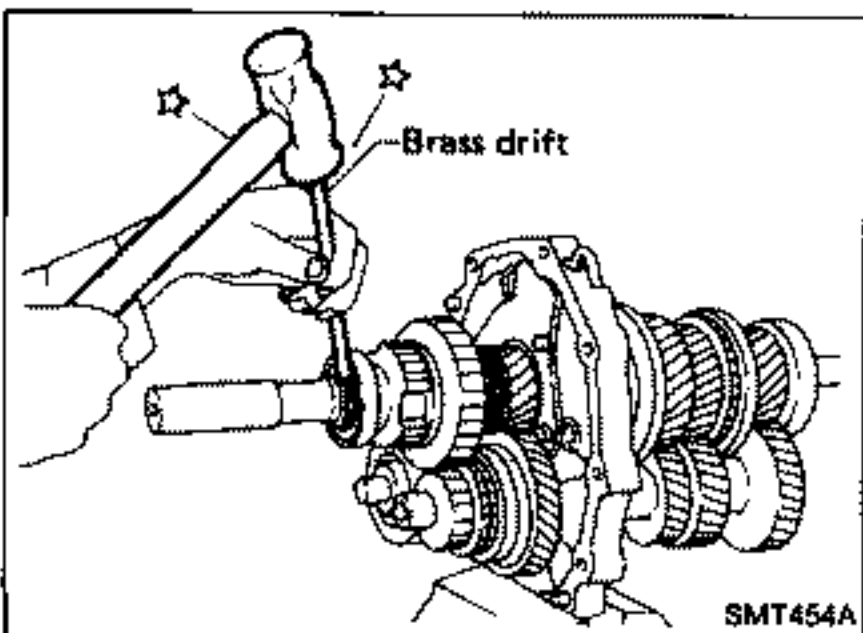

- q. Install selected C-ring, C-ring holder and mainshaft rear snap ring.

## ASSEMBLY

### Gear Components (Cont'd)

- r. Install spacer and then select proper counter gear rear snap ring to minimize clearance of groove.

**Allowable clearance of groove:**

**0 - 0.1 mm (0 - 0.004 in)**

#### Counter gear rear snap ring

Thickness mm (in)	Part number
1.26 (0.0496)	32236-01G08
1.32 (0.0520)	32236-01G00
1.38 (0.0543)	32236-01G01
1.44 (0.0567)	32236-01G02
1.50 (0.0591)	32236-01G03
1.56 (0.0614)	32236-01G04
1.62 (0.0638)	32236-01G05
1.68 (0.0661)	32236-01G06
1.74 (0.0685)	32236-01G07

- s. Install selected counter gear rear snap ring.

- t. Install reverse coupling sleeve.

**Pay attention to its direction.**

- u. Measure each gear end play as a final check — Refer to "DISASSEMBLY".

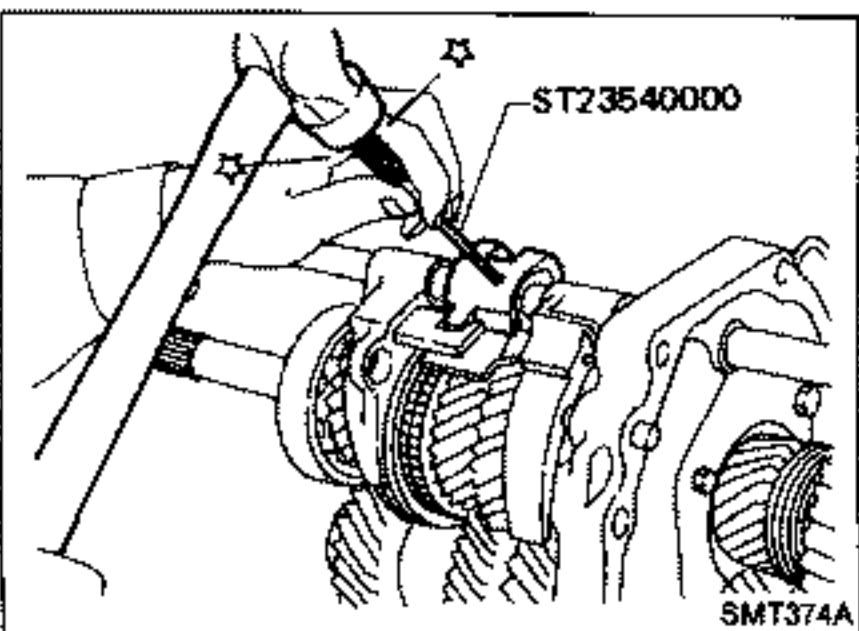
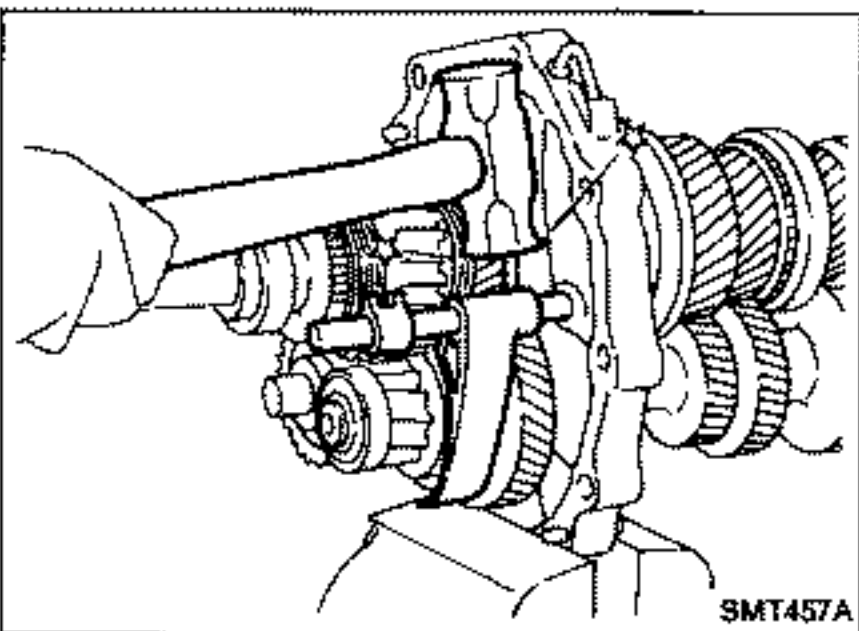
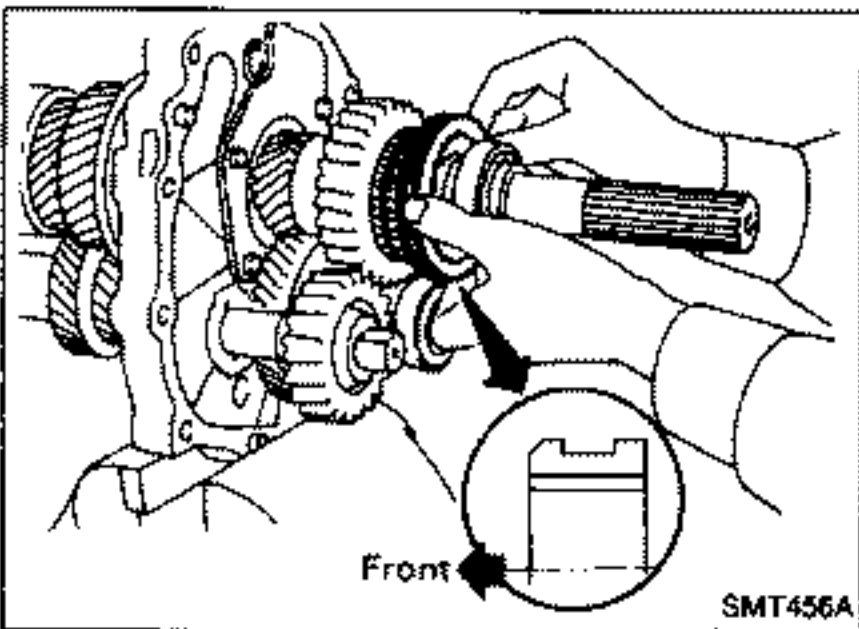
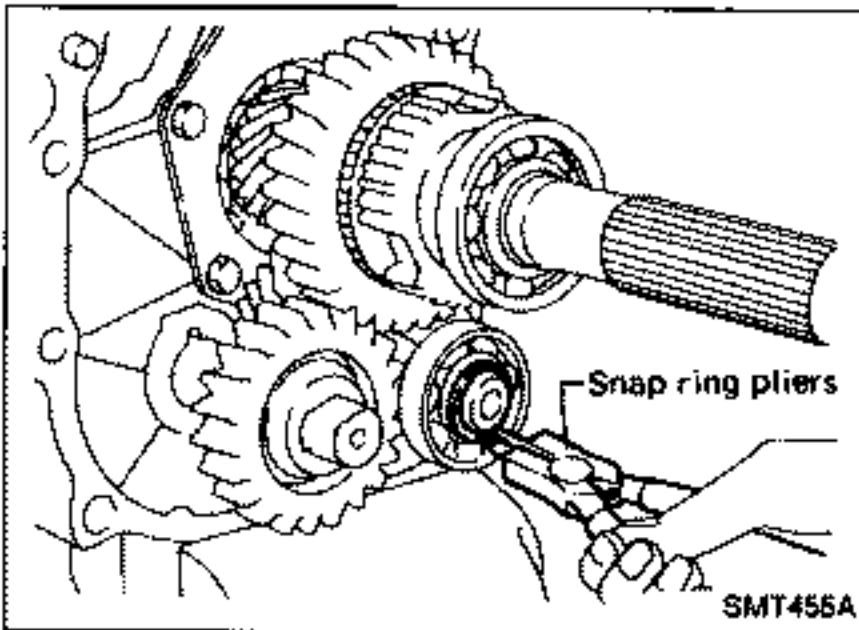
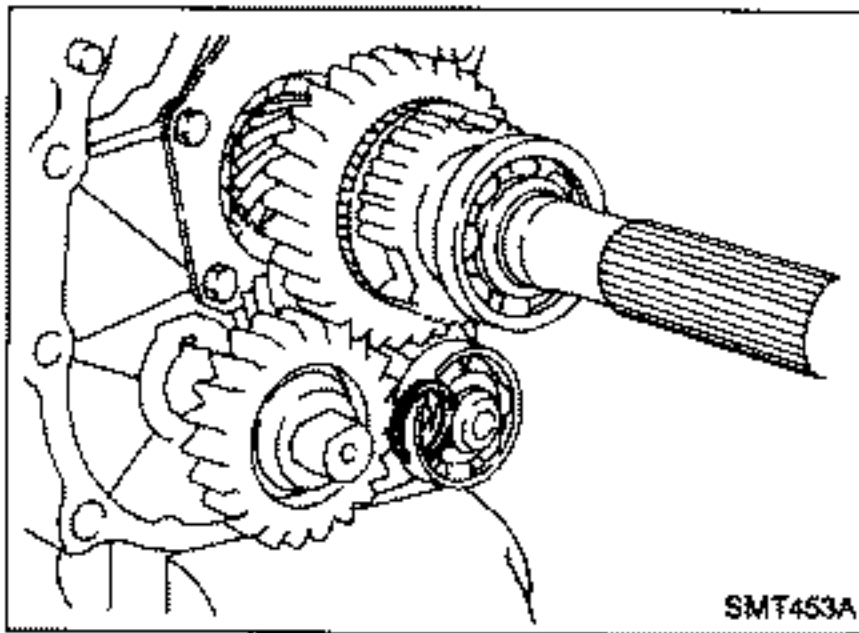

### Shift Control Components

1. Install O.D. fork rod and O.D. shift fork. Then install retaining pin into O.D. shift fork.
2. Install 1st & 2nd, 3rd & 4th and reverse shift forks onto coupling sleeve.
3. Install striking rod into hole of shift forks, striking lever and interlock and then install retaining pin into striking lever.  
**Make sure that striking rod moves smoothly.**

## ASSEMBLY

### Shift Control Components (Cont'd)

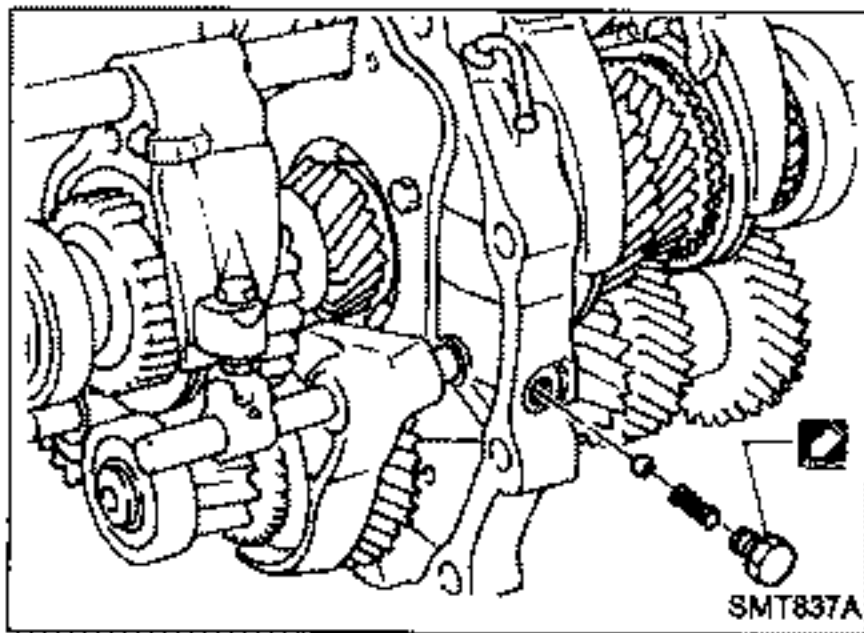

4. Install check ball, return spring and check ball plug.  
**Apply sealant to thread of check ball plug.**

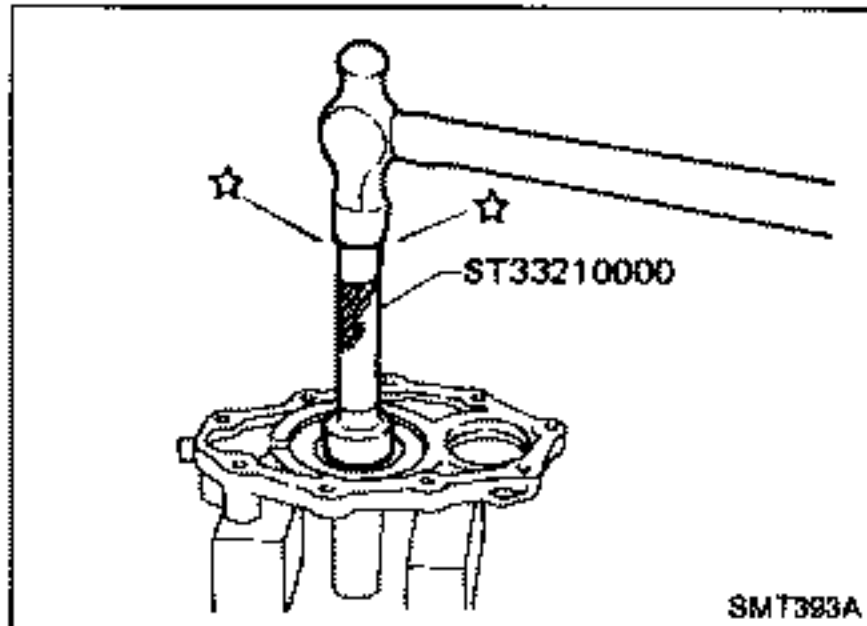

### Case Components

1. Install front cover oil seal.  
**Apply multi-purpose grease to seal lip.**
2. Install selected counter gear front bearing shim onto transmission case.  
**Apply multi-purpose grease.**
3. Apply sealant to mating surface of transmission case.

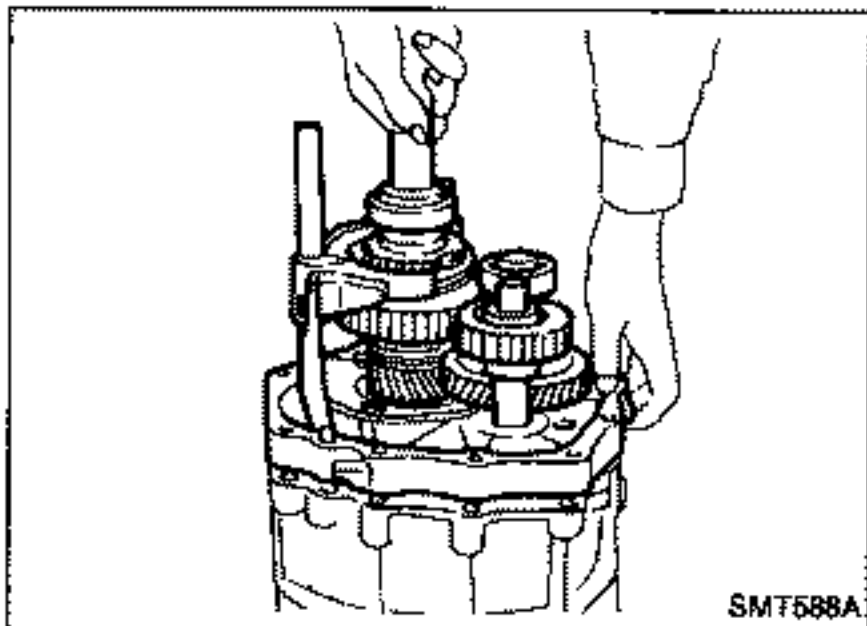

4. Install gear assembly onto transmission case.
5. Install check spring and check ball into interlock stopper.  
**Apply multi-purpose grease to check ball.**

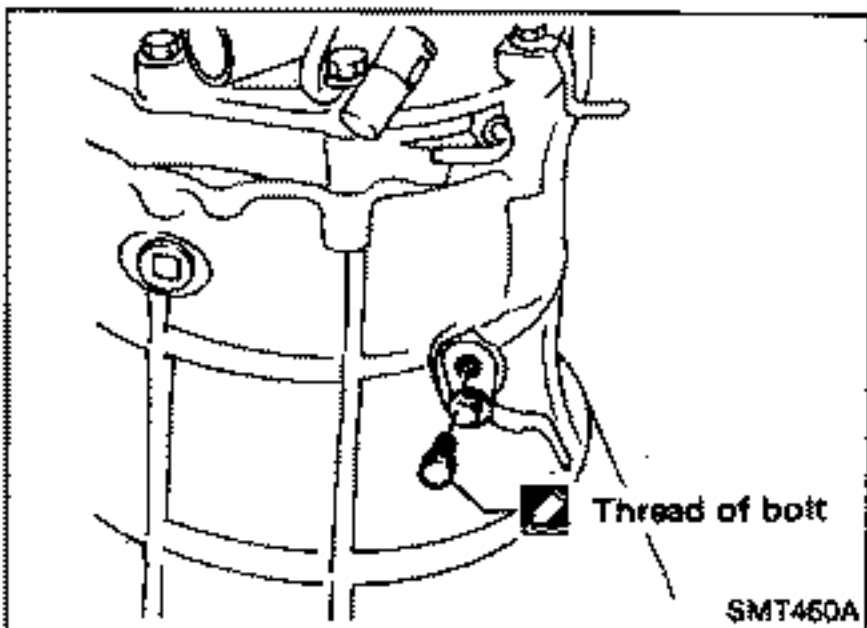

6. Install interlock stopper assembly and then tighten check ball plug.  
**Apply sealant to thread of check ball plug.**

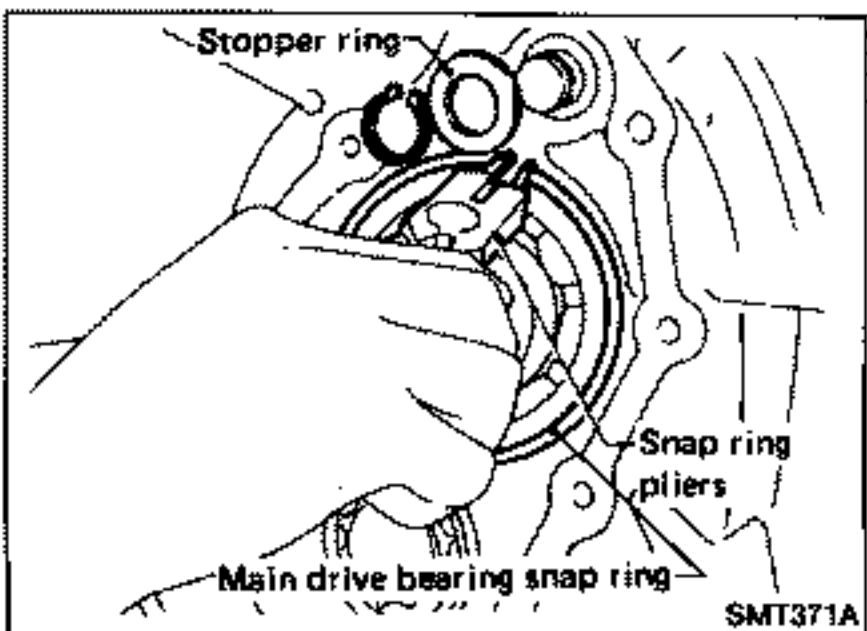

7. Install stopper ring and main drive bearing snap ring.



## ASSEMBLY

### Case Components (Cont'd)

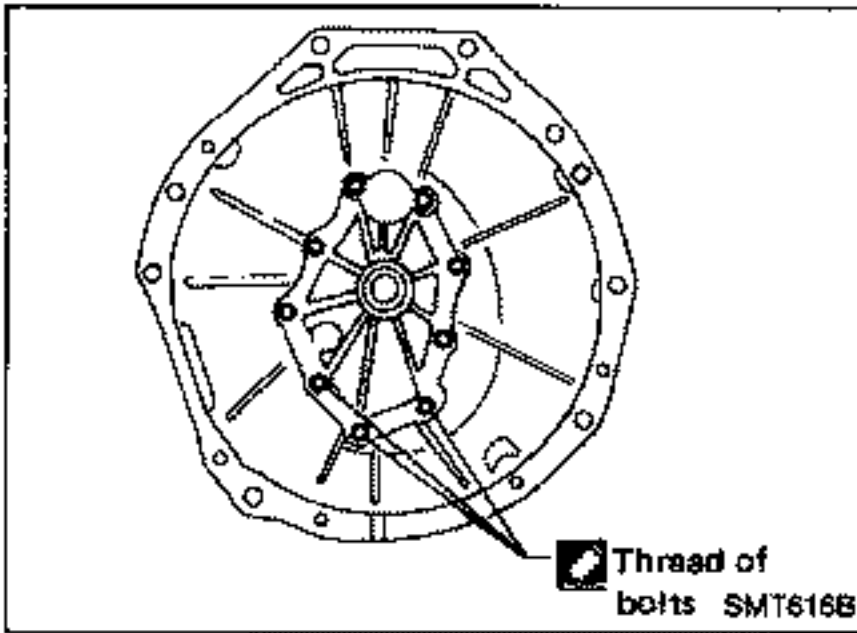

8. Install front cover and gasket.  
**Apply sealant to thread of 3 bolts shown left.**
9. Apply sealant to mating surface of adapter plate.

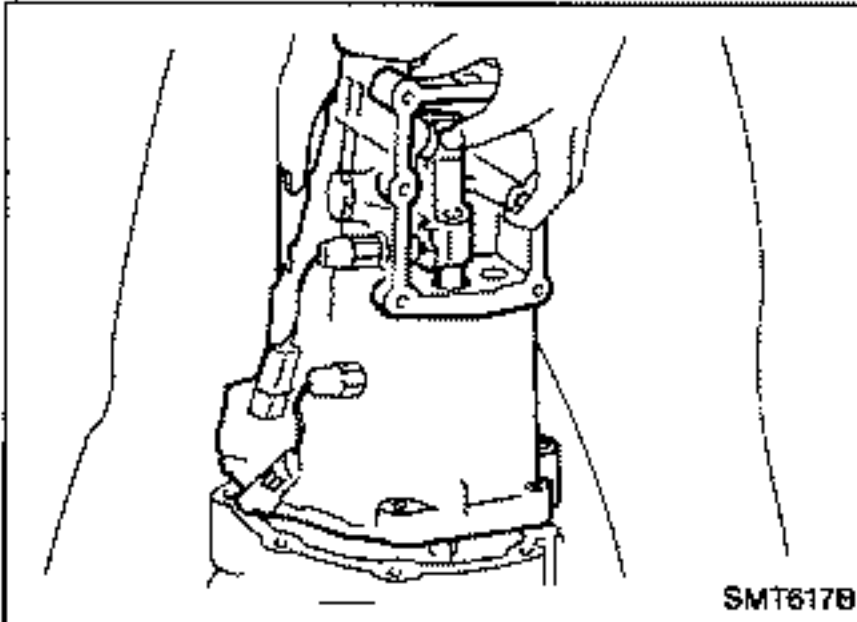

10. Install rear extension together with striking arm.

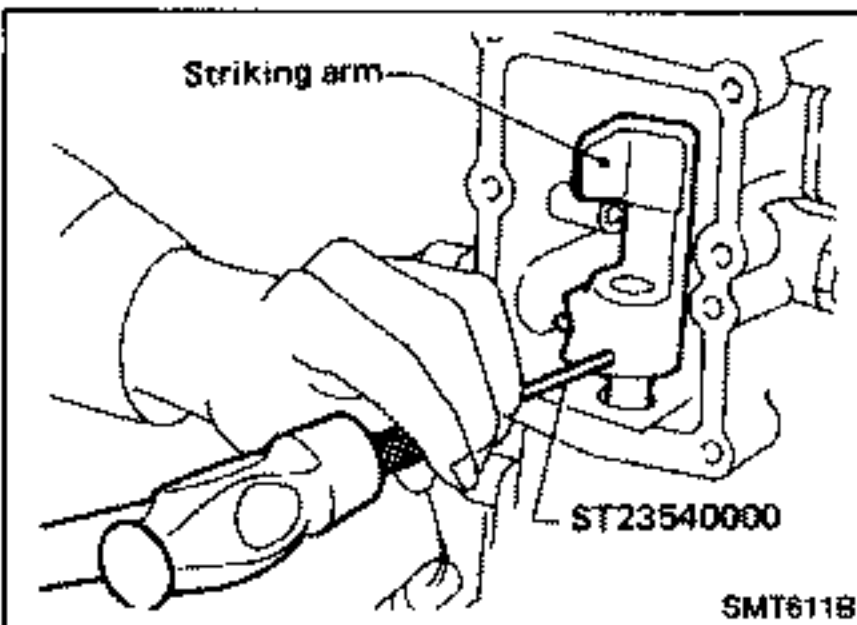

11. Install retaining pin into striking arm.

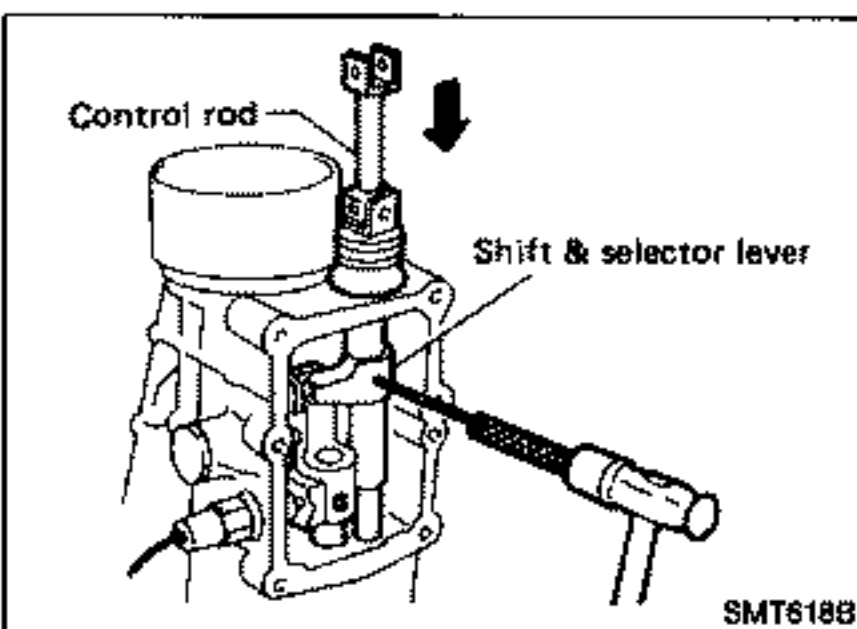

12. Install control rod.  
**Be careful not to damage control rod oil seal and dust cover.**
13. Install retaining pin into shift & selector lever.

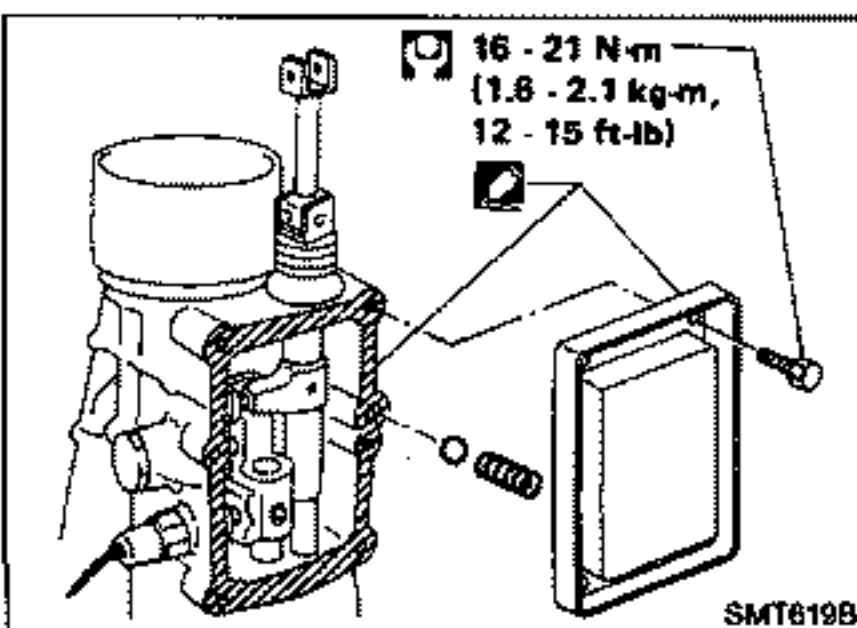

14. Install return spring and check ball and then install control housing.  
**Apply sealant to mating surface of rear extension.**
15. Tighten control housing bolts.

# TRANSMISSION OIL COOLER SYSTEM

FOR EUROPE ONLY

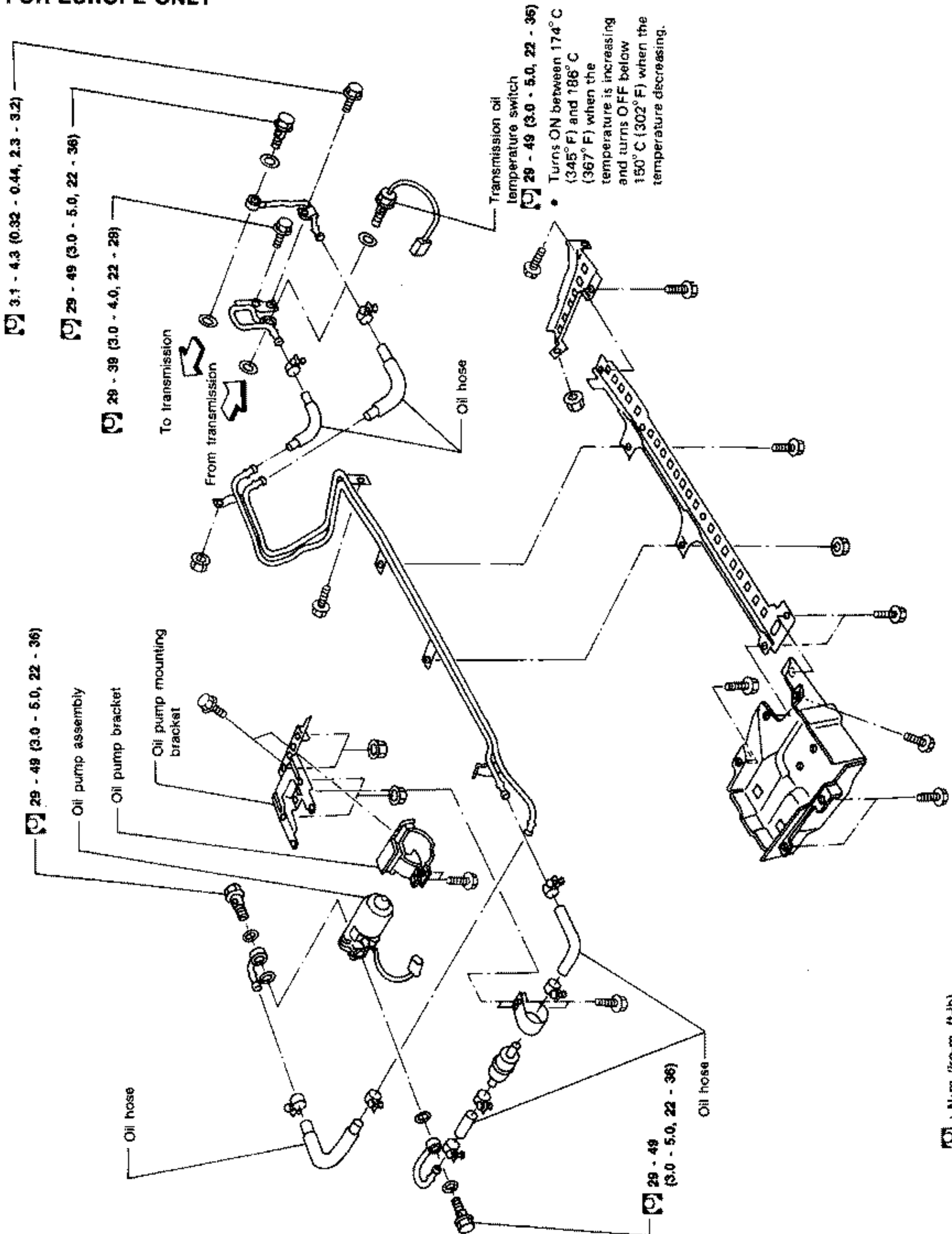

• For Circuit Diagram, Wiring Diagram and oil pump operation, refer to "DIFFERENTIAL OIL COOLER SYSTEM" in PD section.

# SERVICE DATA AND SPECIFICATIONS (S.D.S.)

## General Specifications

Engine	VG30DE	VG30DETT
Transmission model	RS5R30A	
Shift pattern		
Synchromesh type	Warner	
Gear ratio		
1st	3.214	
2nd	1.925	
3rd	1.302	
4th	1.000	
O.D.	0.752	
Reverse	3.369	
Number of teeth		
Main drive gear	23	
Main gear		
1st	31	
2nd	30	
3rd	29	
O.D.	24	
Reverse	30	
Counter drive gear	31	
Counter gear		
1st	13	
2nd	21	
3rd	30	
O.D.	43	
Reverse	12	
Reverse idler gear	22	
Oil capacity	ℓ (Imp pt)	
	2.8 (4-7/8)	3.1 (5-1/2)

# SERVICE DATA AND SPECIFICATIONS (S.D.S.)

## Inspection and Adjustment

### GEAR END PLAY

Gear	End play mm (in)
1st main gear	0.23 - 0.33 (0.0091 - 0.0130)
2nd main gear	0.23 - 0.33 (0.0091 - 0.0130)
3rd main gear	0.23 - 0.33 (0.0091 - 0.0130)
O.D. counter gear	0.23 - 0.33 (0.0091 - 0.0130)
Reverse main gear	0.33 - 0.43 (0.0130 - 0.0169)
Counter gear	0.10 - 0.25 (0.0039 - 0.0098)
Reverse idler gear	0.30 - 0.53 (0.0118 - 0.0209)

### CLEARANCE BETWEEN BAULK RING AND GEAR

#### 1st, main drive and O.D. baulk ring

Unit: mm (in)

	Standard	Wear limit
1st	1.05 - 1.3 (0.0413 - 0.0512)	0.7 (0.028)
Main drive	1.05 - 1.3 (0.0413 - 0.0512)	0.7 (0.028)
O.D.	1.05 - 1.3 (0.0413 - 0.0512)	0.7 (0.028)

#### 2nd and 3rd baulk ring

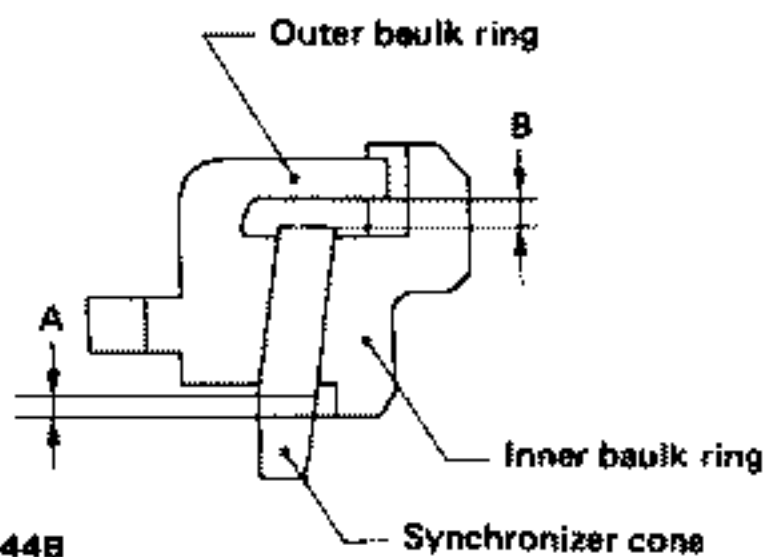

Unit: mm (in)

Dimension	Standard	Wear limit
A	0.6 - 1.1 (0.024 - 0.043)	0.2 (0.008)
B	0.7 - 0.9 (0.028 - 0.035)	0.2 (0.008)

### DISTANCE BETWEEN REAR SURFACE OF REVERSE CONE AND REVERSE BAULK RING

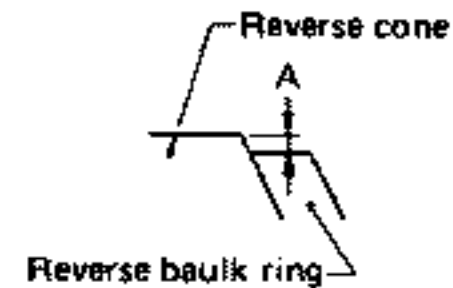

Unit: mm (in)

	Standard	Wear limit
Dimension "A"	-0.1 to 0.35 (-0.0039 to 0.0138)	0.7 (0.028)

### AVAILABLE SNAP RING

#### Main drive gear snap ring

Allowable clearance		0 - 0.1 mm (0 - 0.004 in)
Thickness mm (in)	Part number	
1.89 (0.0744)	32204-01G00	
1.98 (0.0780)	32204-01G01	
2.05 (0.0807)	32204-01G02	
2.12 (0.0835)	32204-01G03	
2.19 (0.0862)	32204-01G04	

#### Mainshaft front snap ring

Allowable clearance		0 - 0.1 mm (0 - 0.004 in)
Thickness mm (in)	Part number	
1.89 (0.0744)	32204-01G00	
1.98 (0.0780)	32204-01G01	
2.05 (0.0807)	32204-01G02	
2.12 (0.0835)	32204-01G03	
2.19 (0.0862)	32204-01G04	

#### Counter gear rear snap ring

Allowable clearance		0 - 0.1 mm (0 - 0.004 in)
Thickness mm (in)	Part number	
1.26 (0.0496)	32236-01G08	
1.32 (0.0520)	32236-01G00	
1.38 (0.0543)	32236-01G01	
1.44 (0.0567)	32236-01G02	
1.50 (0.0591)	32236-01G03	
1.56 (0.0614)	32236-01G04	
1.62 (0.0638)	32236-01G05	
1.68 (0.0661)	32236-01G06	
1.74 (0.0685)	32236-01G07	

# SERVICE DATA AND SPECIFICATIONS (S.D.S.)

## Inspection and Adjustment (Cont'd)

### AVAILABLE C-RING

#### Mainshaft C-ring

Allowable clearance		0 - 0.1 mm (0 - 0.004 in)	
Thickness mm (in)	Part number	Thickness mm (in)	Part number
2.63 (0.1035)	32348-01G15	3.19 (0.1256)	32348-01G07
2.70 (0.1063)	32348-01G00	3.26 (0.1283)	32348-01G08
2.77 (0.1091)	32348-01G01	3.33 (0.1311)	32348-01G09
2.84 (0.1118)	32348-01G02	3.40 (0.1339)	32348-01G10
2.91 (0.1146)	32348-01G03	3.47 (0.1366)	32348-01G11
2.98 (0.1173)	32348-01G04	3.54 (0.1394)	32348-01G12
3.05 (0.1201)	32348-01G05	3.61 (0.1421)	32348-01G13
3.12 (0.1228)	32348-01G06	3.68 (0.1449)	32348-01G14

### AVAILABLE SHIM AND WASHER

#### Table for selecting proper counter gear front bearing shim

Dial indicator deflection mm (in)	Thickness of proper washer mm (in)	Part number
0.93 - 1.02 (0.0366 - 0.0402)	0.8 (0.031)	32218-01G00
1.03 - 1.12 (0.0406 - 0.0441)	0.9 (0.035)	32218-01G01
1.13 - 1.22 (0.0445 - 0.0480)	1.0 (0.039)	32218-01G02
1.23 - 1.32 (0.0484 - 0.0520)	1.1 (0.043)	32218-01G03
1.33 - 1.42 (0.0524 - 0.0559)	1.2 (0.047)	32218-01G04
1.43 - 1.52 (0.0563 - 0.0598)	1.3 (0.051)	32218-01G05
1.53 - 1.62 (0.0602 - 0.0638)	1.4 (0.055)	32218-01G06

#### Reverse idler thrust washer

Thickness mm (in)	Part number
1.97 (0.0776)	32284-01G10
2.07 (0.0815)	32284-01G11