

ENGINE LUBRICATION & COOLING SYSTEMS

SECTION LC



LC

CONTENTS

PREPARATION	LC- 2
PRECAUTION	LC- 3
ENGINE LUBRICATION SYSTEM	LC- 4
ENGINE COOLING SYSTEM	LC- 8
SERVICE DATA AND SPECIFICATIONS (S.D.S.)	LC-15

PREPARATION

SPECIAL SERVICE TOOLS

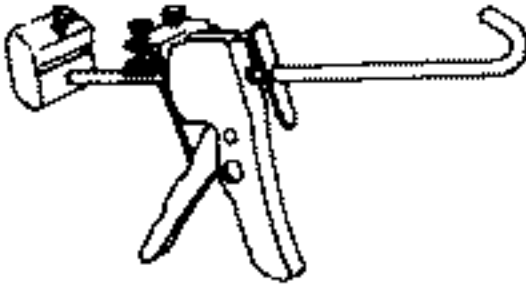
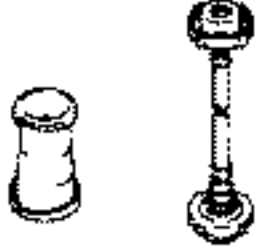
Tool number Tool name	Description	
ST25051001 Oil pressure gauge		
ST25052000 Hose	Adapting oil pressure gauge to cylinder block	
WS39930000 Tube presser	Pressing the tube of liquid gasket	
EG17650301 Radiator cap tester adapter	Adapting radiator cap tester to radiator filler neck	

PRECAUTION

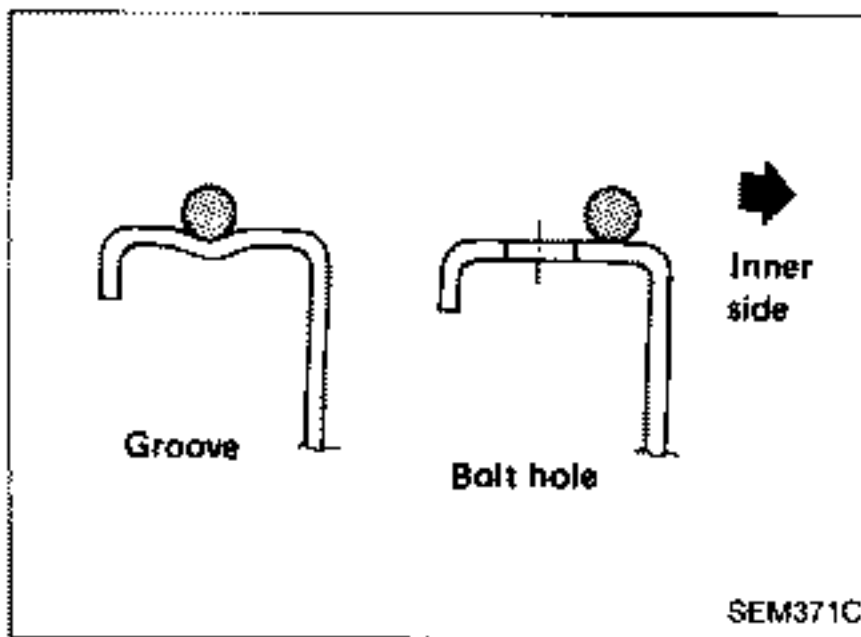

LIQUID GASKET APPLICATION PROCEDURE

- a. Before applying liquid gasket, use a scraper to remove all traces of old liquid gasket from mating surface.
- b. Apply a continuous bead of liquid gasket to mating surfaces. (Use Genuine Liquid Gasket or equivalent.)
 - Be sure liquid gasket is 3.5 to 4.5 mm (0.138 to 0.177 in) wide (for oil pan).
 - Be sure liquid gasket is 2.0 to 3.0 mm (0.079 to 0.118 in) wide (in areas except oil pan).
- c. Apply liquid gasket to inner sealing surface around hole perimeter area.
(Assembly should be done within 5 minutes after coating.)

ENGINE LUBRICATION SYSTEM

Lubrication Circuit

Valve timing control system

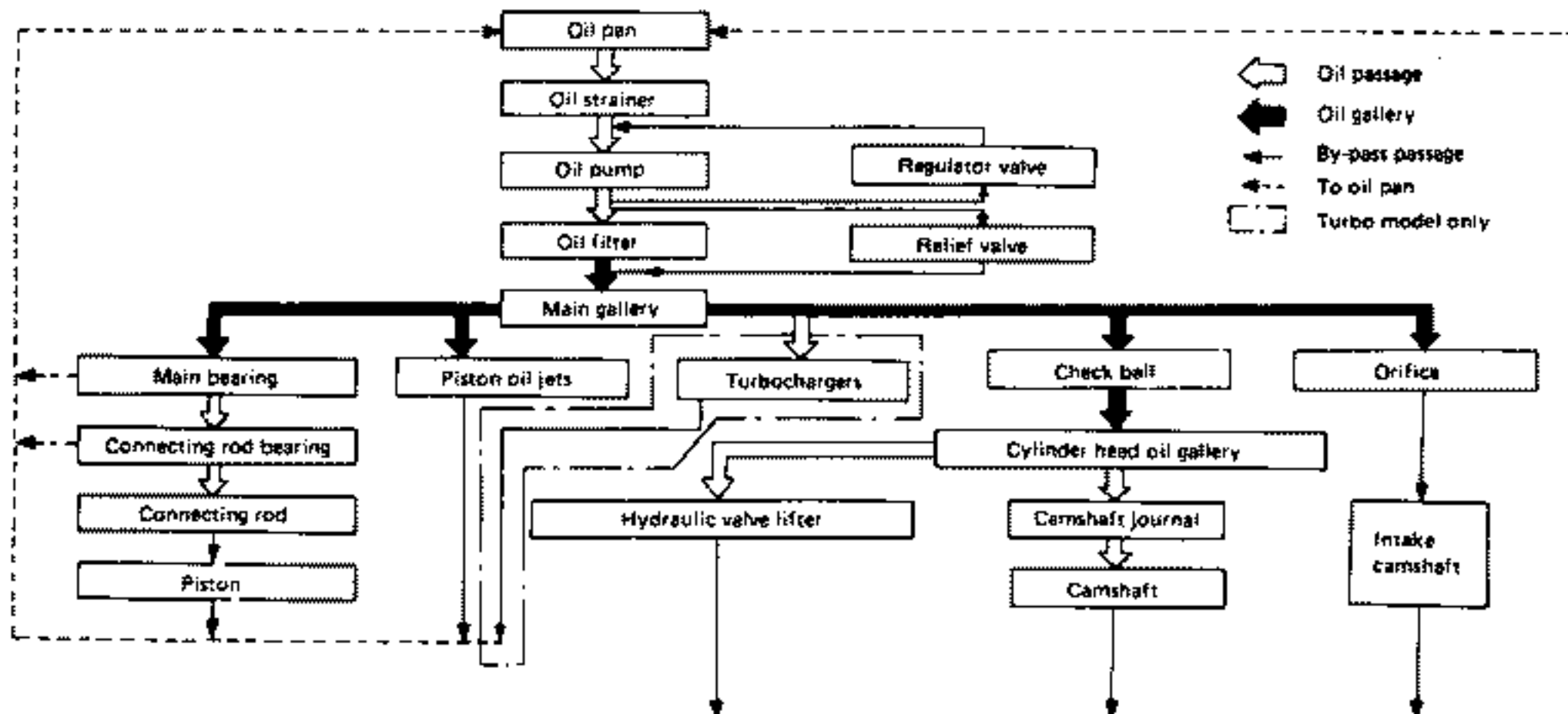
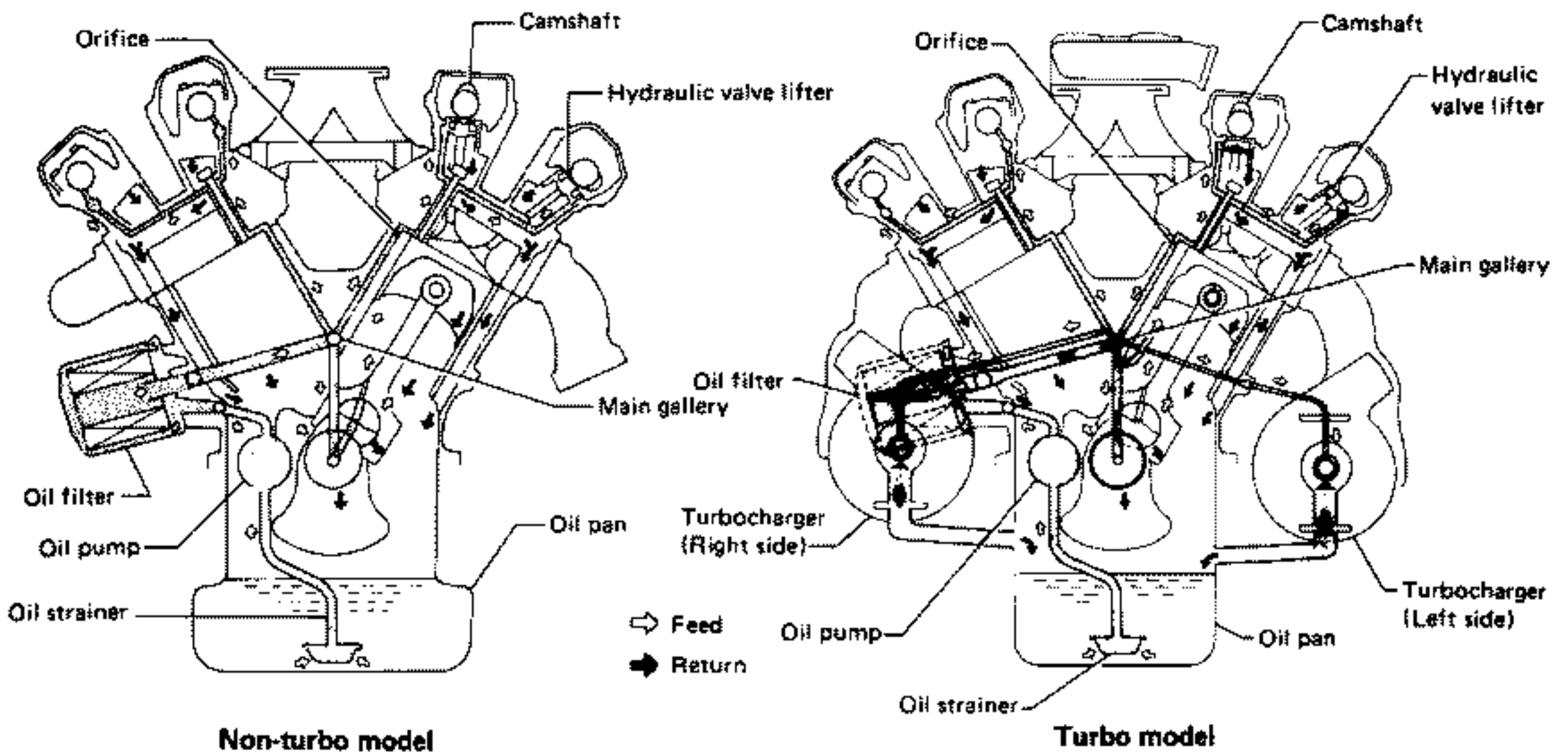
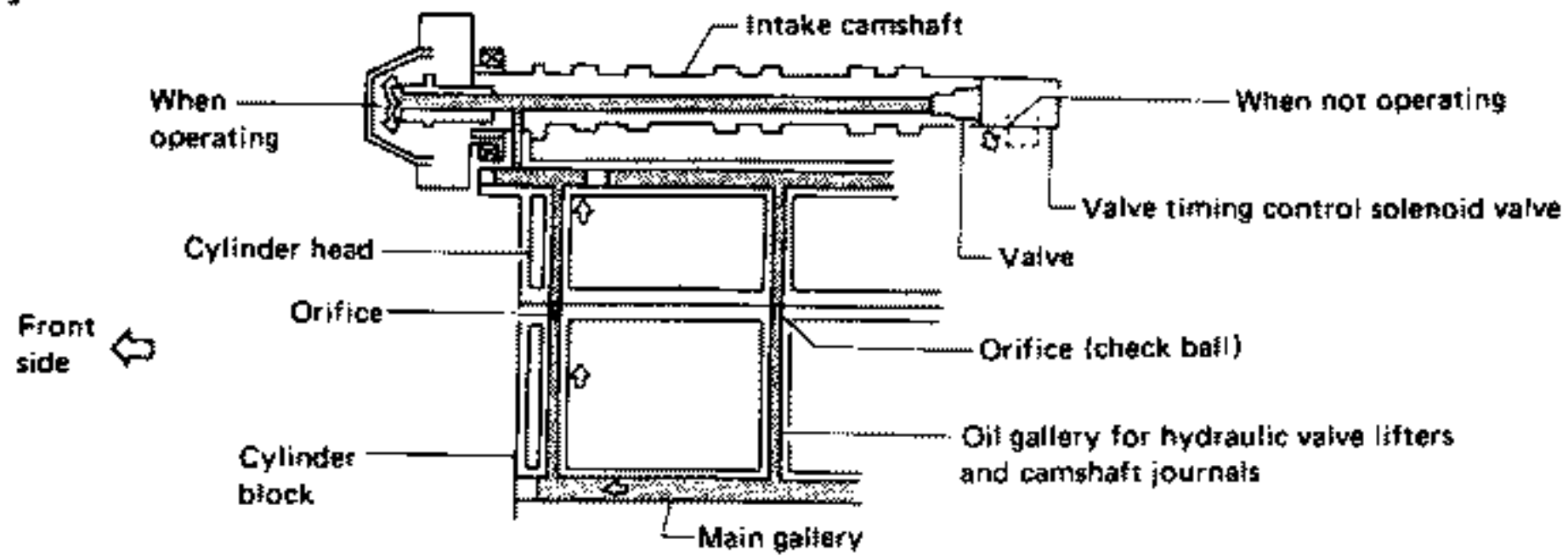

ENGINE LUBRICATION SYSTEM

Oil Pressure Check

WARNING:

- Be careful not to burn yourself, as the engine and oil may be hot.
- Oil pressure check should be done in "Neutral" gear position.

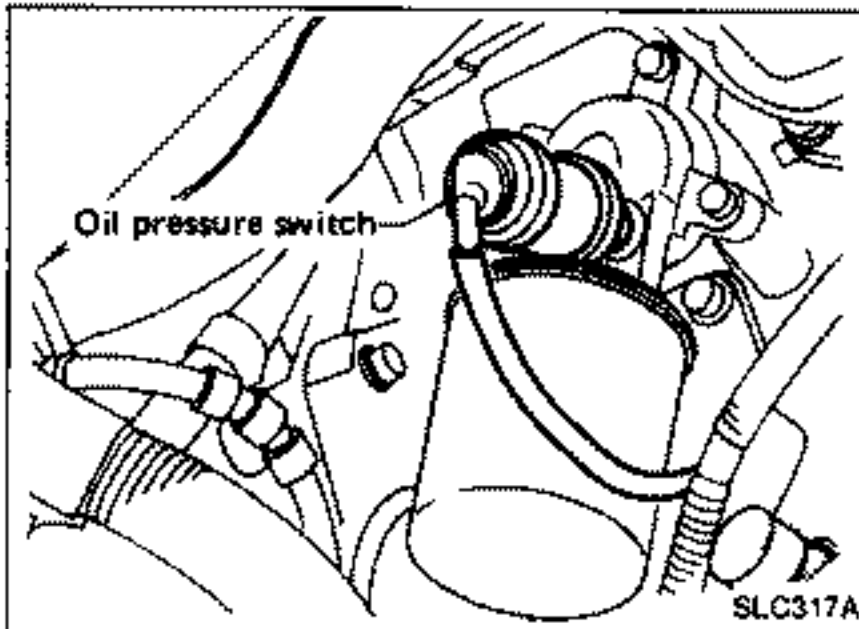

1. Check oil level.
2. Remove oil pressure switch.

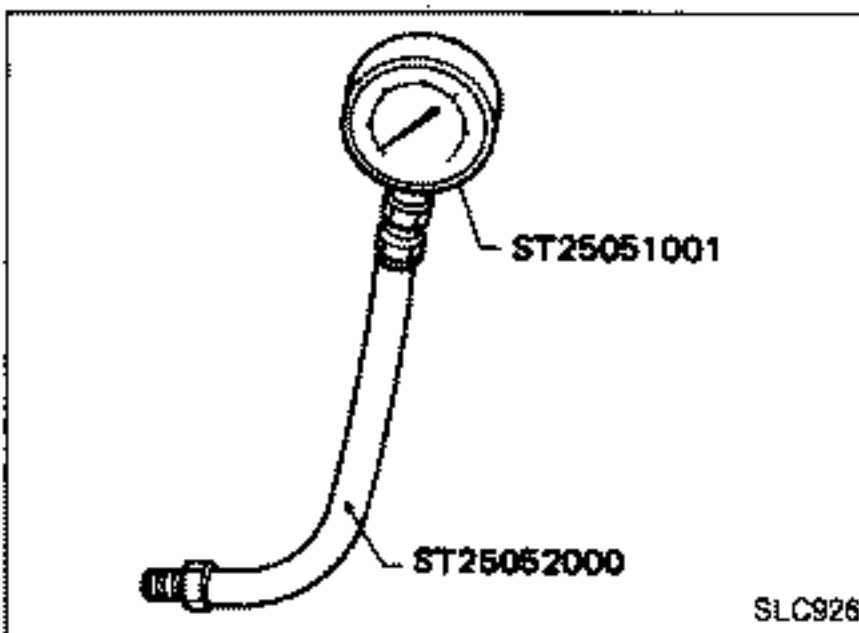

3. Install pressure gauge.
4. Start engine and warm it up to normal operating temperature.
5. Check oil pressure with engine running under no-load.

Engine rpm	Approximate discharge pressure kPa (bar, kg/cm ² , psi)
Idle speed	More than 78 (0.78, 0.8, 11)
3,000	353 - 451 (3.53 - 4.51, 3.6 - 4.6, 51 - 65)

If difference is extreme, check oil passage and oil pump for oil leaks.

6. Install oil pressure switch with sealant.

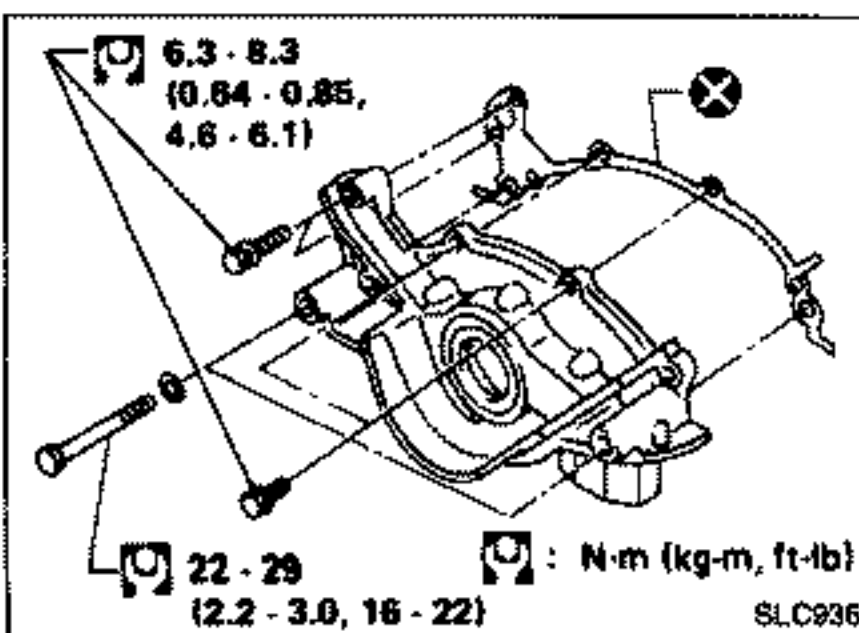

Oil Pump

REMOVAL

1. Drain oil.
2. Remove oil pan. (Refer to "OIL PAN — Removal" in EM section.)
3. Remove oil pump assembly.

ENGINE LUBRICATION SYSTEM

Oil Pump (Cont'd)

DISASSEMBLY AND ASSEMBLY

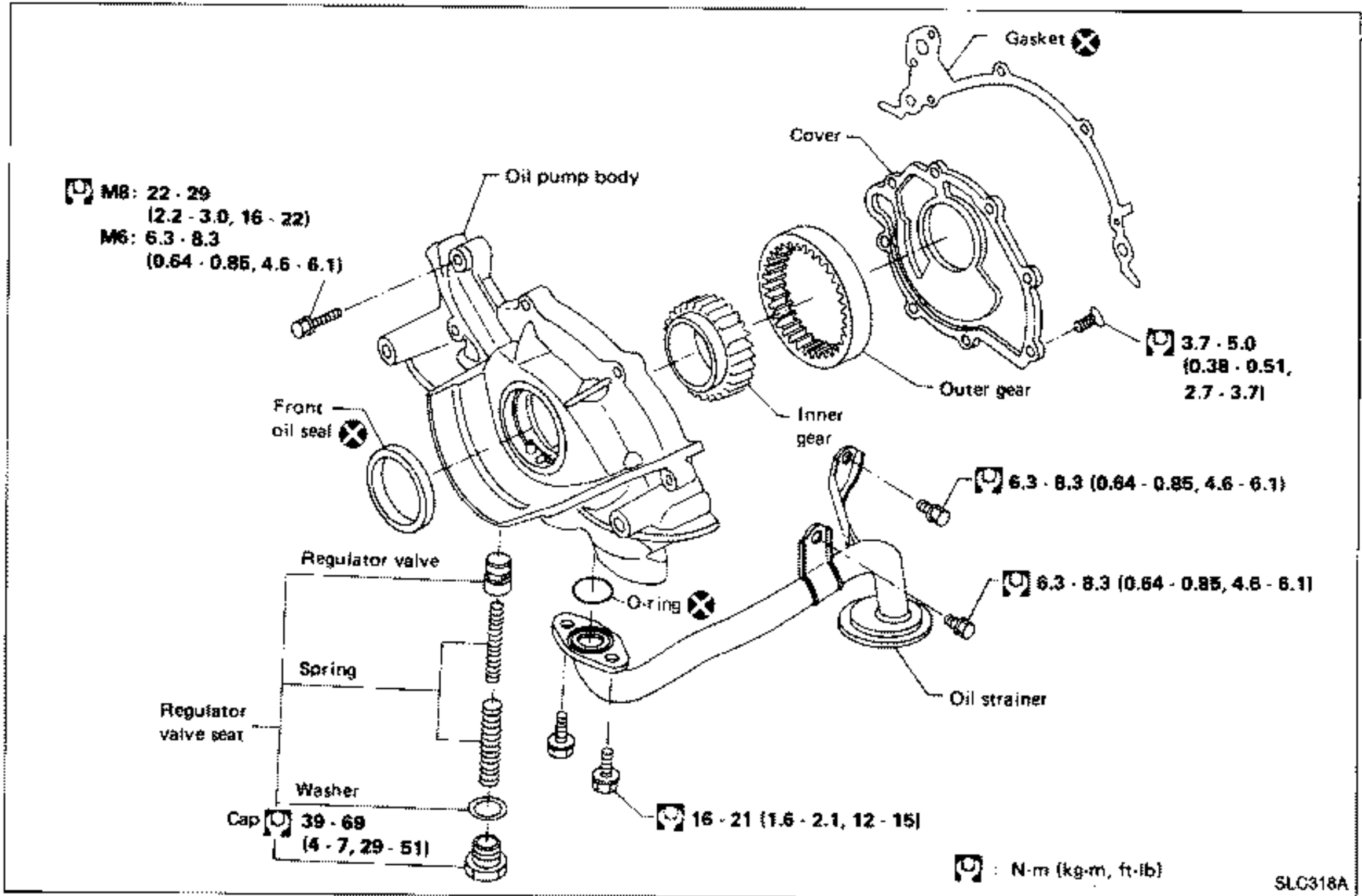

- Always replace with new oil seal and gasket.
- When installing oil pump, apply engine oil to inner and outer gears.
- Be sure that O-ring is properly installed.

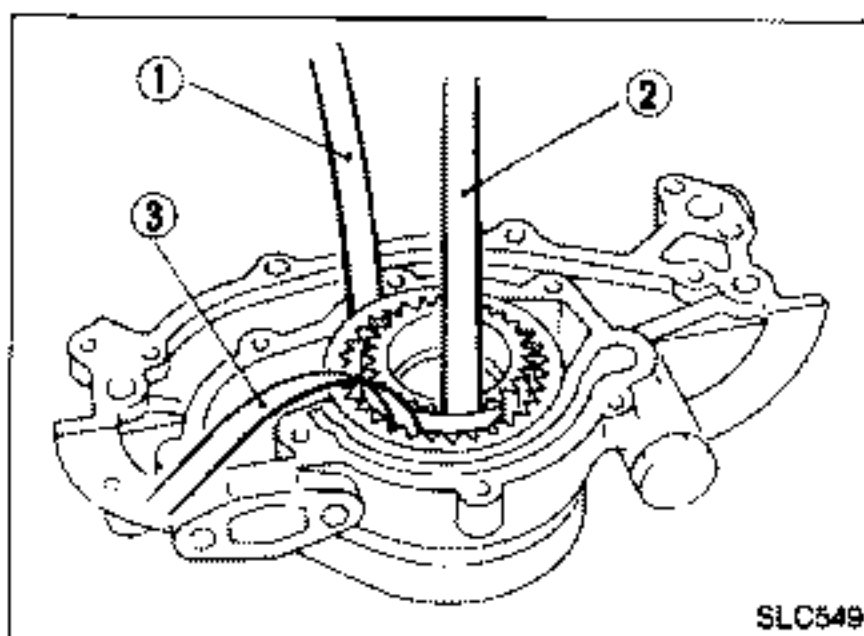

INSPECTION

Using a feeler gauge, check the following clearances:

Standard clearance:

Unit: mm (in)

Body to outer gear clearance ①	0.110 - 0.200 (0.0043 - 0.0079)
Inner gear to crescent clearance ②	0.223 - 0.333 (0.0088 - 0.0131)
Outer gear to crescent clearance ③	0.210 - 0.320 (0.0083 - 0.0126)
Housing to inner gear clearance ④	0.050 - 0.090 (0.0020 - 0.0035)
Housing to outer gear clearance ⑤	0.050 - 0.110 (0.0020 - 0.0043)

If any clearance exceeds the limit, replace gear set or entire oil pump assembly.

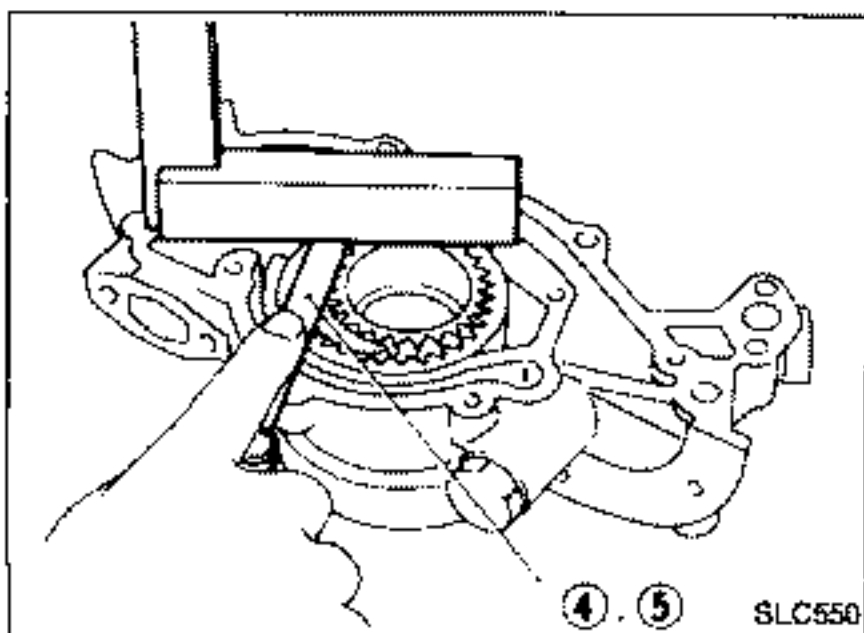

ENGINE LUBRICATION SYSTEM

Oil Pump (Cont'd)

REGULATOR VALVE INSPECTION

1. Visually inspect components for wear and damage.
2. Check oil pressure regulator valve sliding surface and valve spring.
3. Coat regulator valve with engine oil and check to make sure that it falls smoothly into the valve hole by its own weight.

If damaged, replace regulator valve set or oil pump assembly.

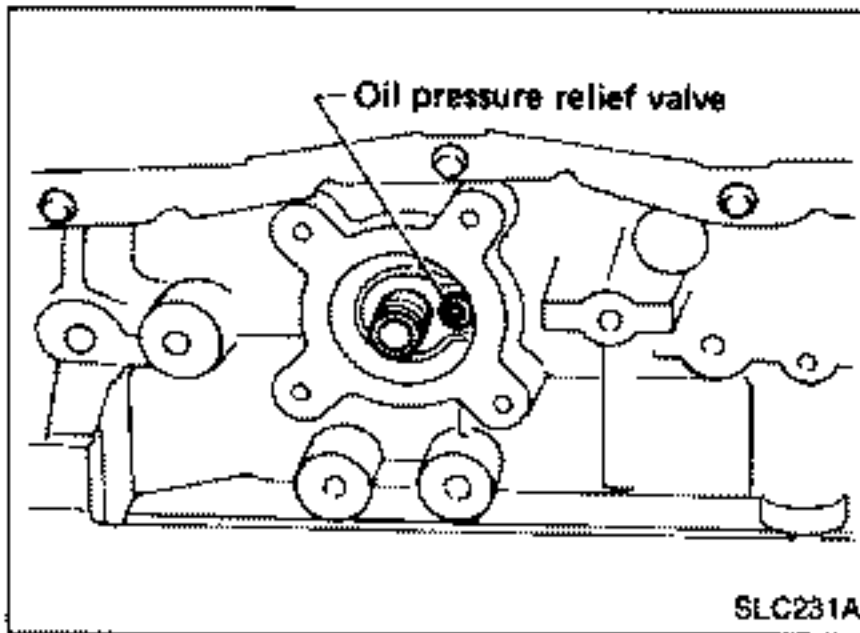
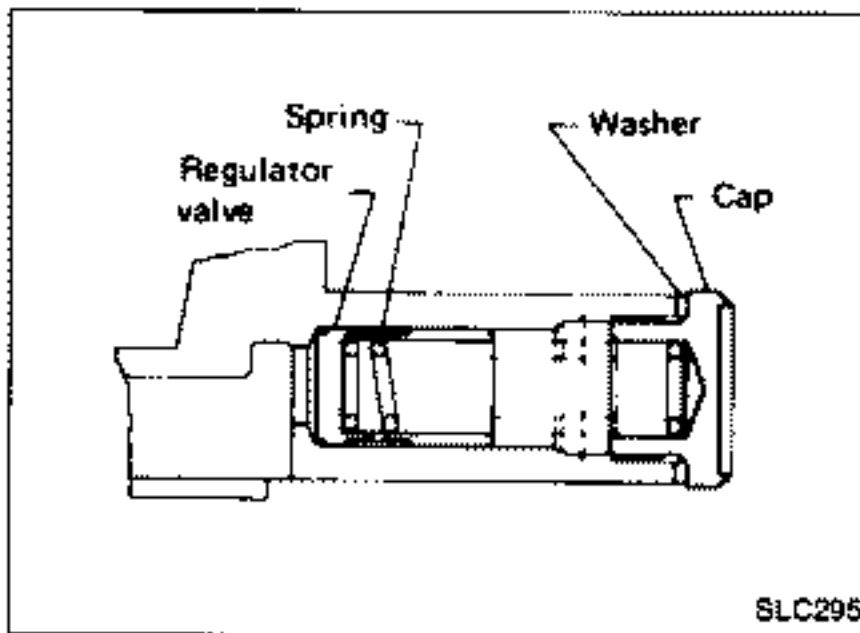

OIL PRESSURE RELIEF VALVE INSPECTION

Inspect oil pressure relief valve for movement, cracks and breaks by pushing the ball. If replacement is necessary, remove valve by prying it out with a suitable tool. Install a new valve by tapping it in place.

ENGINE COOLING SYSTEM

Cooling Circuit

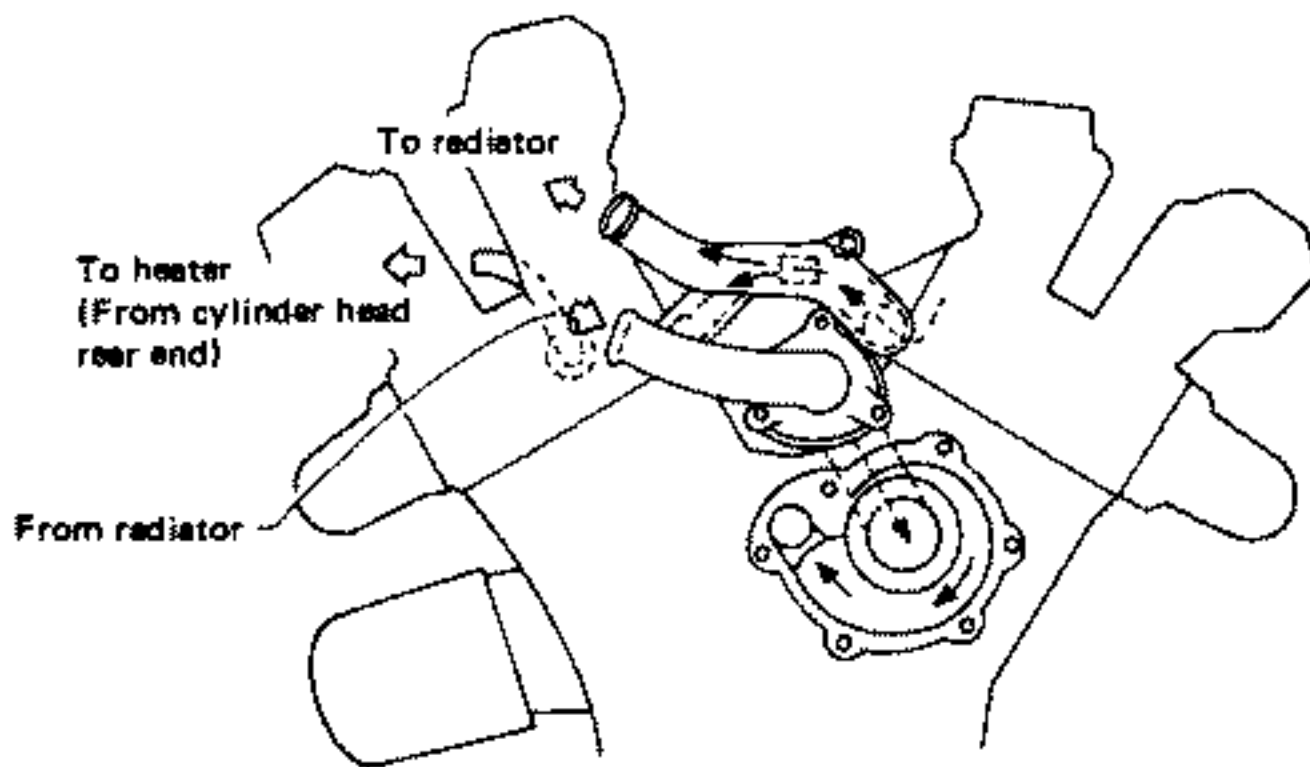
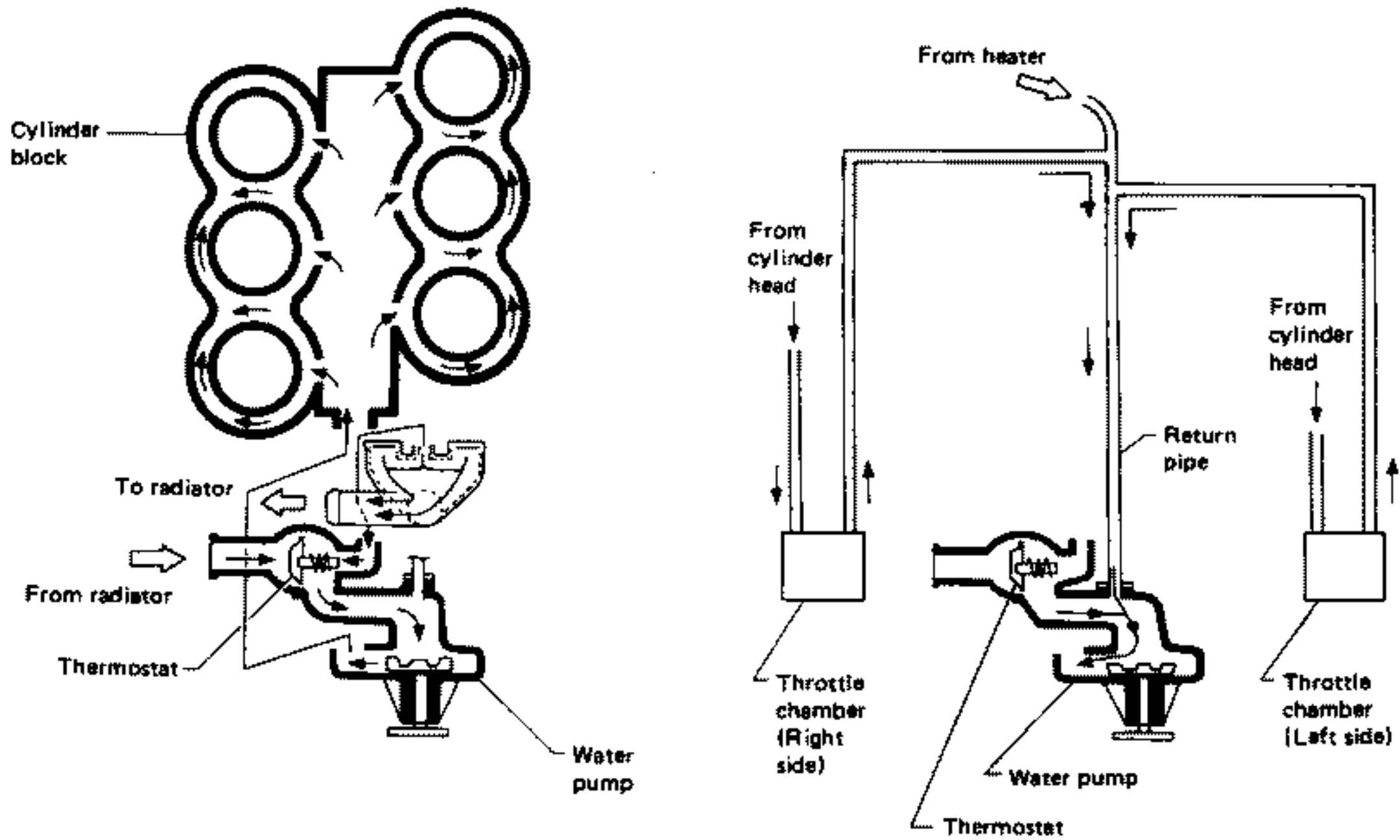

- ◀ : Thermostat open
- ◀ : Thermostat closed
- ◻ : Turbo model only

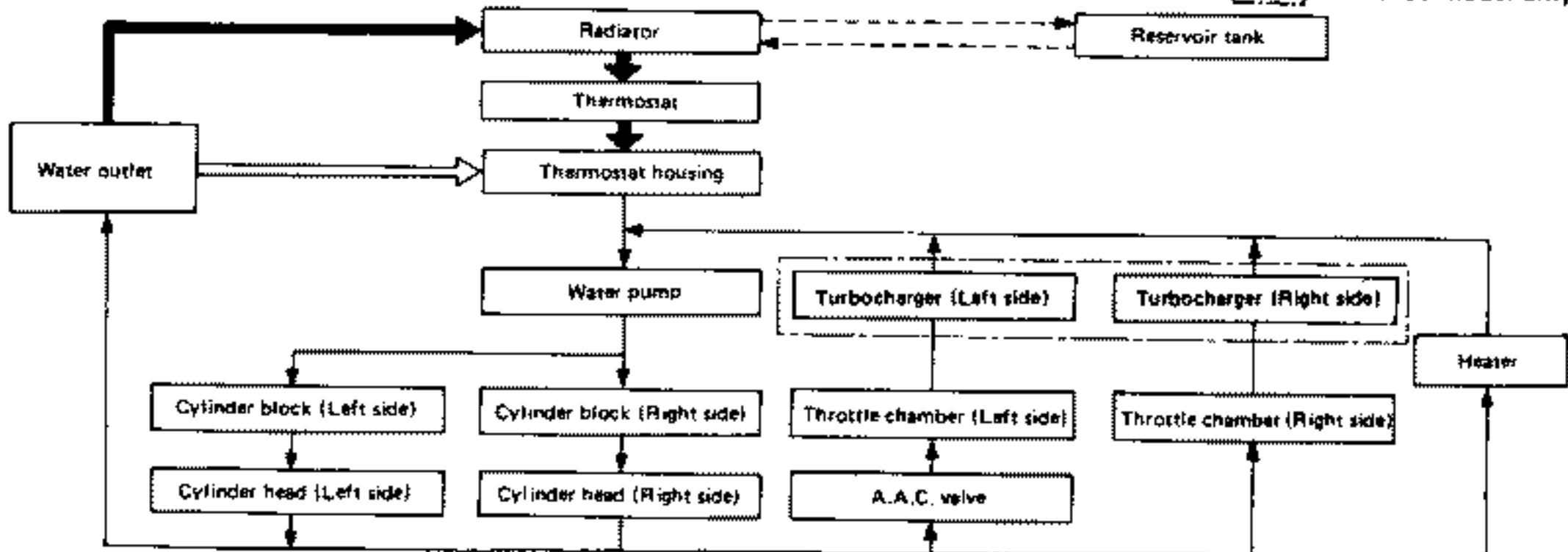

ENGINE COOLING SYSTEM

System Check

WARNING:

Never remove the radiator cap when the engine is hot; serious burns could be caused by high pressure fluid escaping from the radiator.

Wrap a thick cloth around the cap and carefully remove by turning it a quarter turn to allow built-up pressure to escape. Then continue to turn the cap until it can be removed safely.

CHECKING COOLING SYSTEM HOSES

Check hoses for improper attachment, leaks, cracks, damage, loose connections, chafing and deterioration.

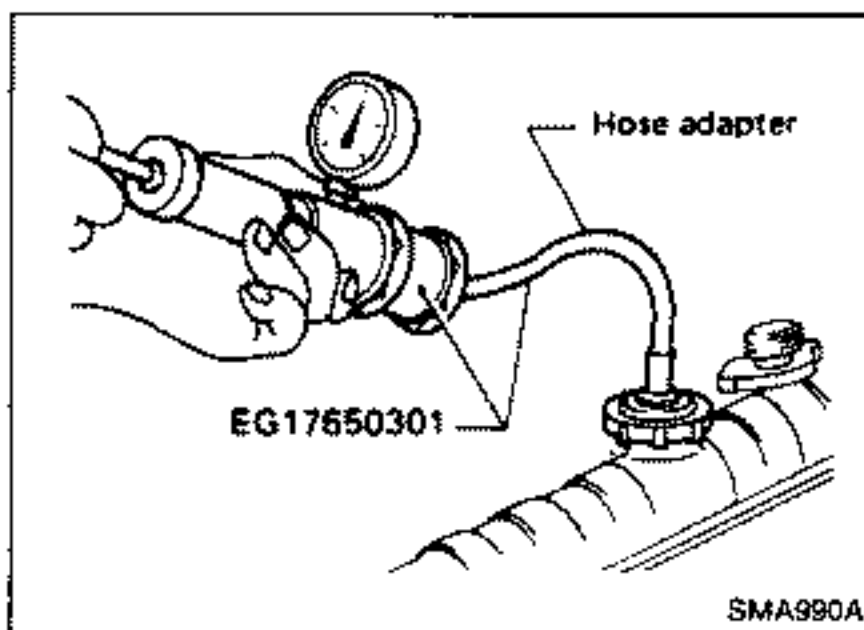

CHECKING COOLING SYSTEM FOR LEAKS

To check for leakage, apply pressure to the cooling system with a tester.

Testing pressure:

98 kPa (0.98 bar, 1.0 kg/cm², 14 psi)

CAUTION:

Higher than the specified pressure may cause radiator damage.

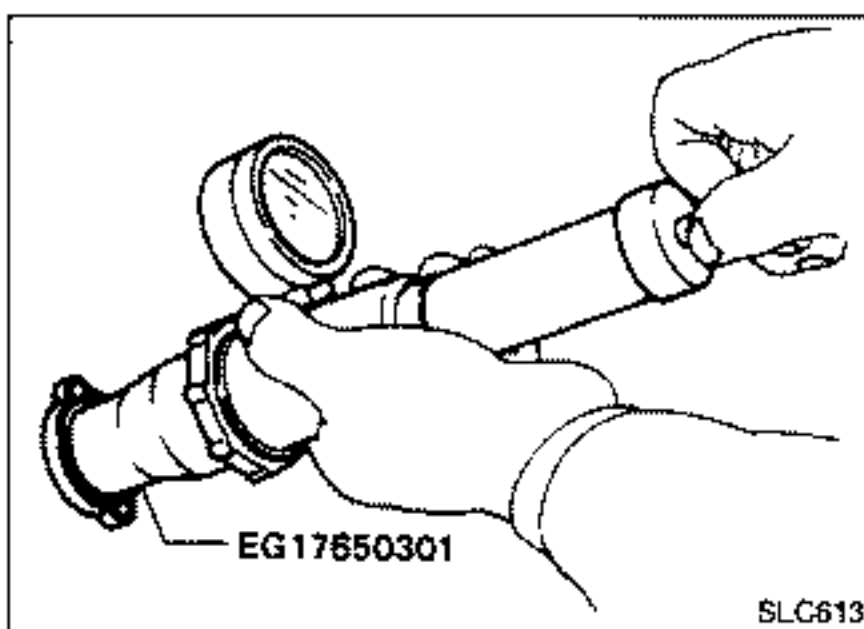

CHECKING RADIATOR CAP

To check radiator cap, apply pressure to cap with a tester.

Radiator cap relief pressure:

78 - 98 kPa (0.78 - 0.98 bar, 0.8 - 1.0 kg/cm²,

11 - 14 psi)

Water Pump

REMOVAL AND INSTALLATION

1. Drain coolant from drain cocks on both sides of cylinder block and radiator.
2. Remove the following parts:
 - Under cover
 - Radiator
 - Drive belts
 - Cooling fan and coupling
 - Water inlet and outlet

ENGINE COOLING SYSTEM

Water Pump (Cont'd)

- Crank pulley
- Timing belt cover
- 3. Remove water pump.
- 4. After repairing or replacing water pump, install any parts removed in reverse order of removal.

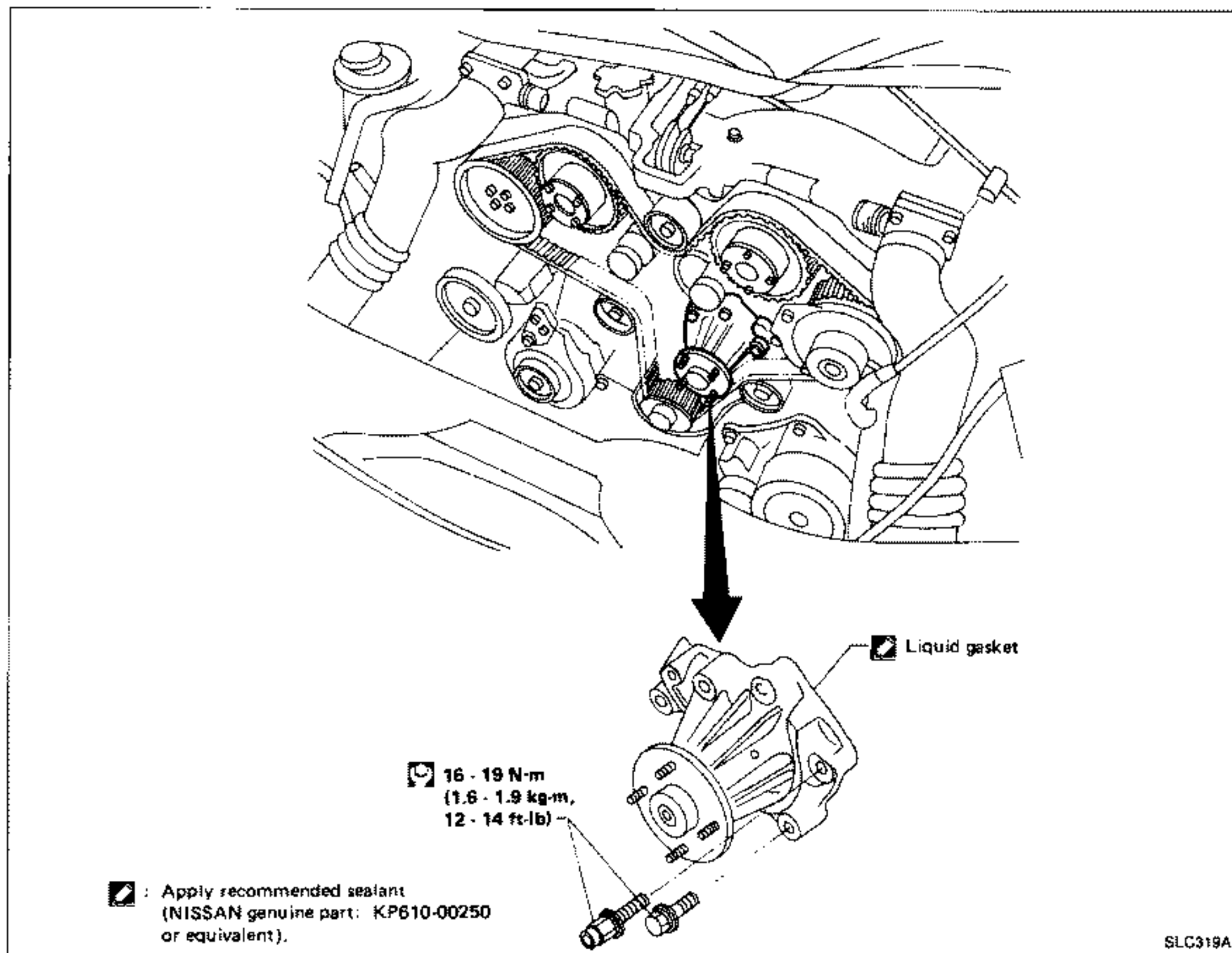

CAUTION:

- When removing water pump assembly, be careful not to get coolant on timing belt.
- Water pump cannot be disassembled and should be replaced as a unit.
- After installing water pump, connect hose and clamp securely, then check for leaks using radiator cap tester.

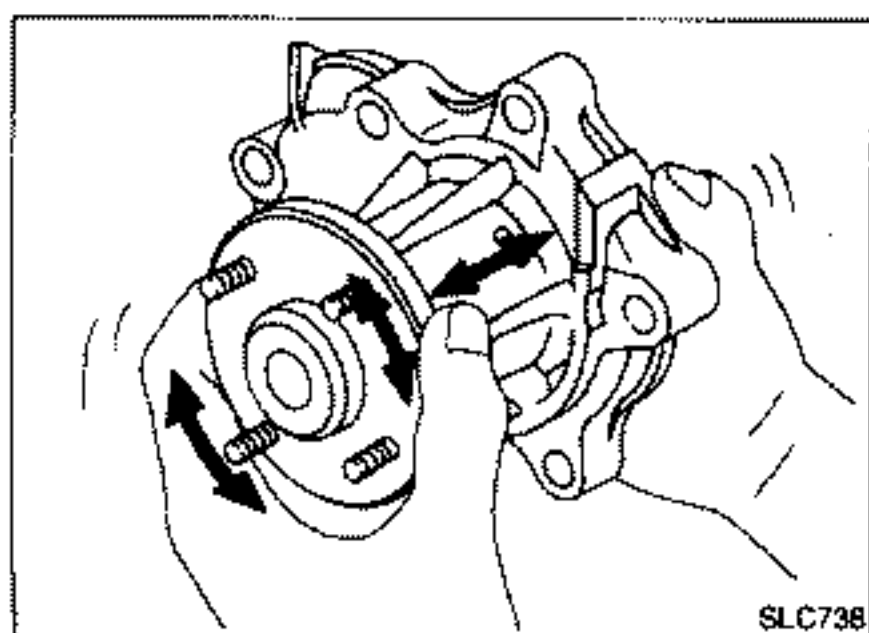

INSPECTION

1. Check for badly rusted or corroded vanes and body assembly.
2. Check for rough operation due to excessive end play.

ENGINE COOLING SYSTEM

Thermostat

REMOVAL AND INSTALLATION

1. Drain coolant from drain cocks on both sides of cylinder block and radiator.
2. Remove the following parts:
 - Under cover
 - Radiator upper hose
 - Radiator shroud
 - Fan belt
 - Cooling fan and coupling
 - Water inlet
3. Remove thermostat.

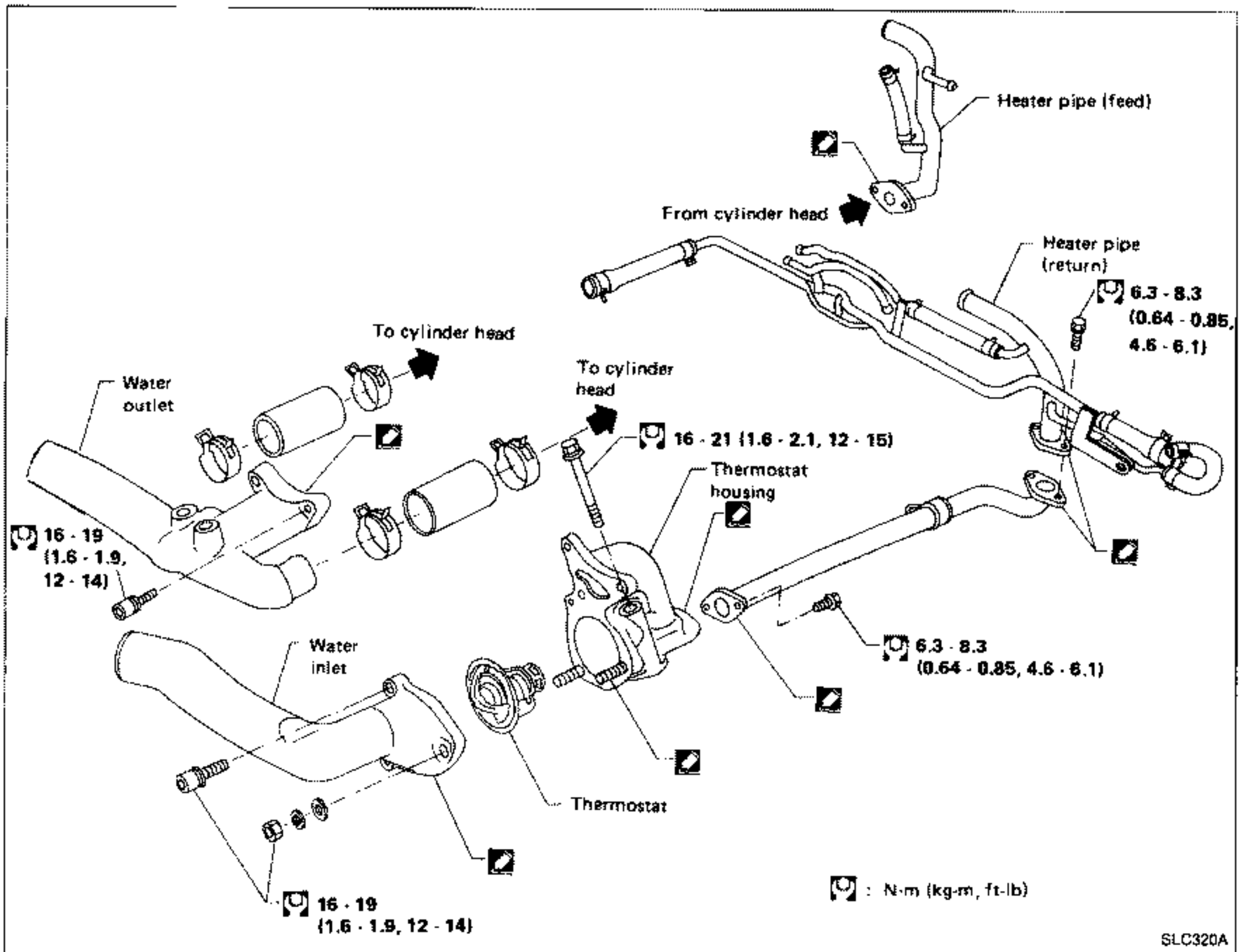

4. After repairing or replacing thermostat, install thermostat with jiggle valve facing upward.

ENGINE COOLING SYSTEM

Thermostat (Cont'd)

INSPECTION

1. Check valve seating condition at ordinary room temperatures. It should seat tightly.

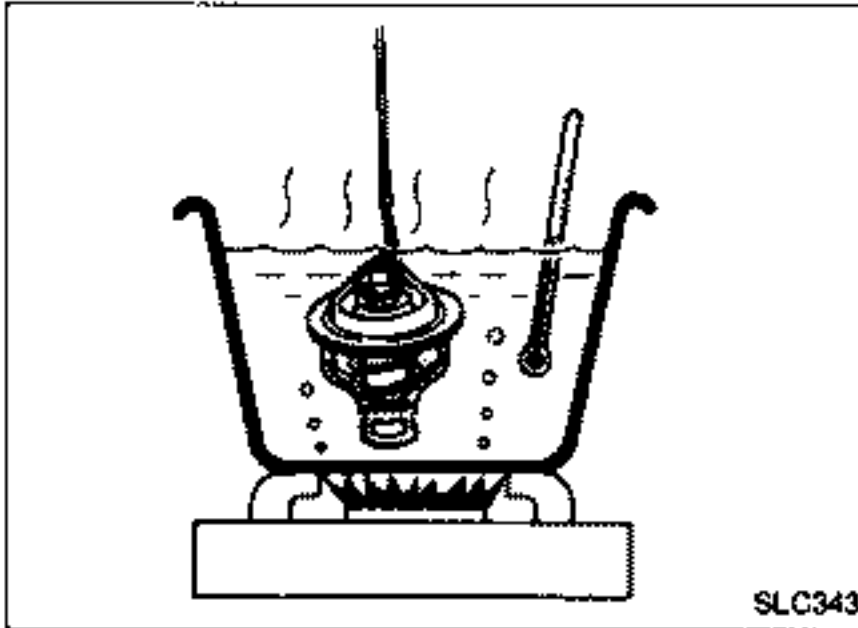

2. Check valve opening temperature and maximum valve lift.

		Standard
Valve opening temperature	°C (°F)	76.5 (170)
Maximum valve lift	mm/°C (in/°F)	10/90 (0.39/194)

3. Then check if valve is 5°C (9°F) below valve opening temperature.
- **After installation, run engine for a few minutes, and check for leaks.**
 - **Be careful not to spill coolant over engine compartment. Use a rag to absorb coolant.**

ENGINE COOLING SYSTEM

Radiator

REMOVAL AND INSTALLATION

1. Drain coolant from radiator drain cock.
2. Remove under cover.
3. Disconnect radiator upper and lower hoses.
4. Remove A/T oil cooler hoses. (A/T model only)
5. Remove radiator lower shroud.
6. Remove radiator.
7. After repairing or replacing radiator, install any part removed in reverse order of removal.

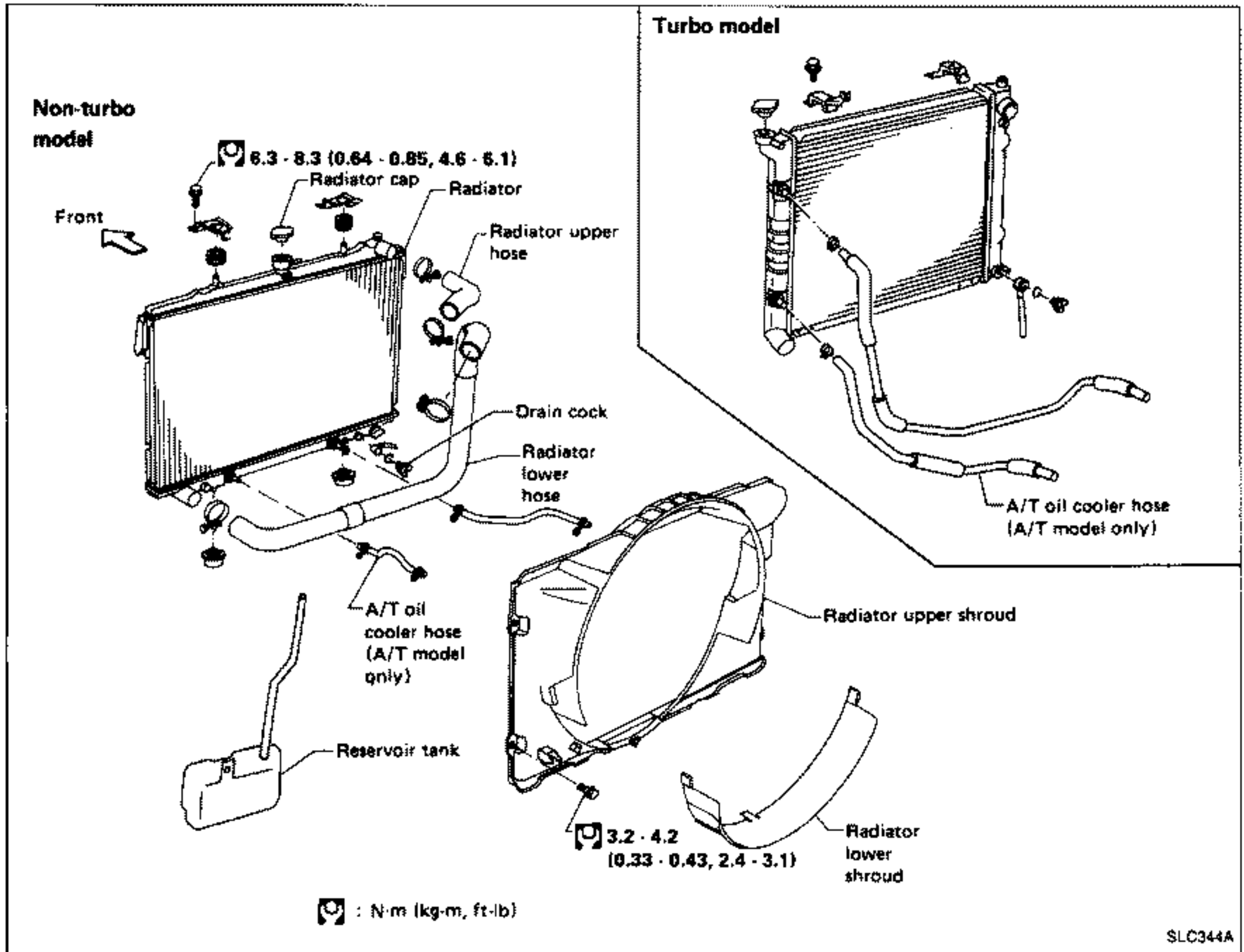

Electric Cooling Fan Control System

Radiator (Condenser) fan is controlled by E.C.C.S. control unit. For details, refer to EF & EC section.

ENGINE COOLING SYSTEM

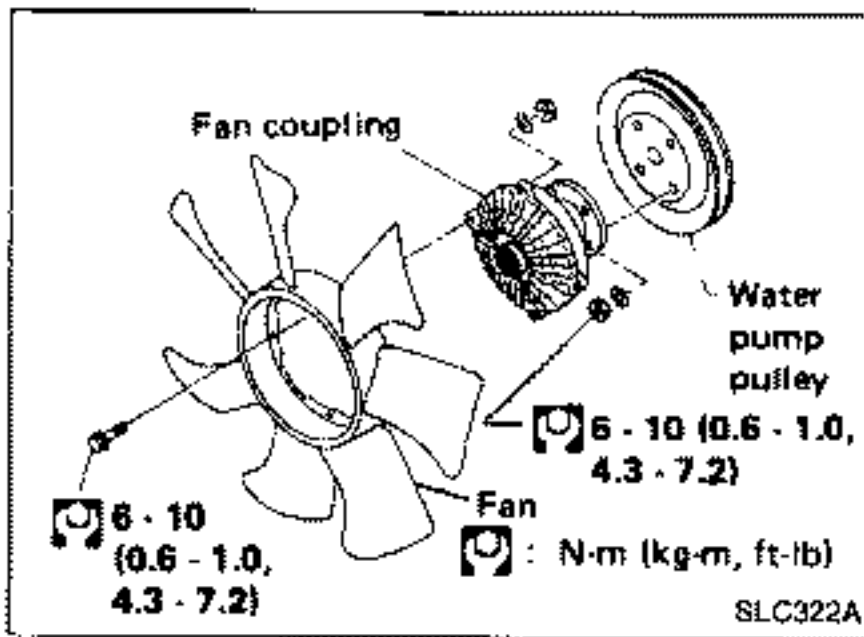

Cooling Fan

DISASSEMBLY AND ASSEMBLY

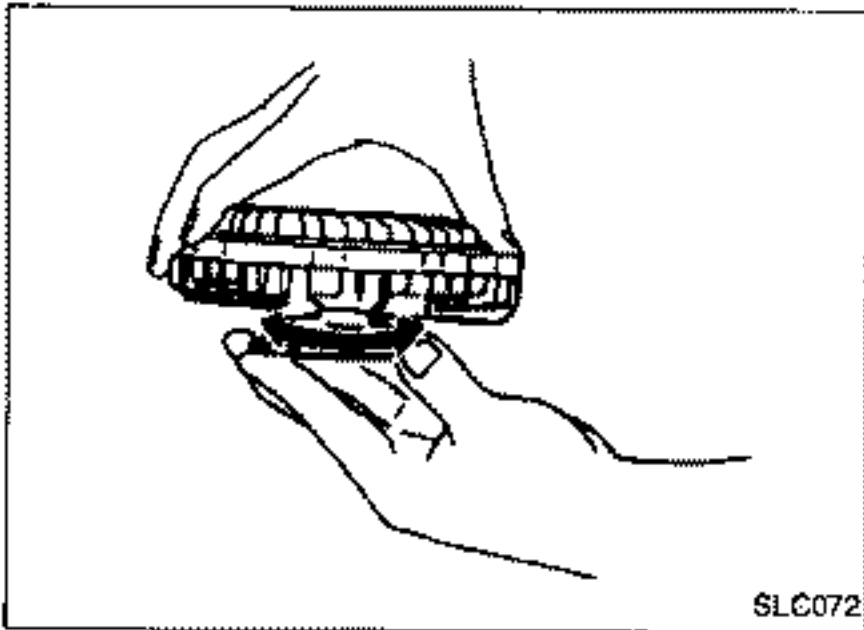

INSPECTION

Check fan coupling for rough operation, oil leakage or bent bimetal.

SERVICE DATA AND SPECIFICATIONS (S.D.S.)

Engine Lubrication System

Oil pressure check

Engine rpm	Approximate discharge pressure kPa (bar, kg/cm ² , psi)
Idle speed	More than 78 (0.78, 0.8, 11)
3,000	353 - 451 (3.53 - 4.51, 3.6 - 4.6, 51 - 65)

Oil pump

	Unit: mm (in)
Body to outer gear clearance ①	0.110 - 0.200 (0.0043 - 0.0079)
Inner gear to crescent clearance ②	0.223 - 0.333 (0.0088 - 0.0131)
Outer gear to crescent clearance ③	0.210 - 0.320 (0.0083 - 0.0126)
Housing to inner gear side clearance ④	0.050 - 0.090 (0.0020 - 0.0035)
Housing to outer gear side clearance ⑤	0.050 - 0.110 (0.0020 - 0.0043)

Engine Cooling System

Thermostat

	Standard
Valve opening temperature °C (°F)	76.5 (170)
Maximum valve lift mm/°C (in/°F)	10/90 (0.39/194)