

# REAR AXLE & REAR SUSPENSION

## SECTION **RA**

### CONTENTS

REAR AXLE AND REAR SUSPENSION .....	RA- 2
REAR AXLE – Axle Shaft .....	RA- 4
DRIVE SHAFT .....	RA- 6
DRIVE SHAFT – “Tripod-Tripod” Type .....	RA- 7
DRIVE SHAFT – “Double Offset-Birfield” Type .....	RA-12
REAR SUSPENSION .....	RA-15
REAR SUSPENSION – Adjustable Shock Absorber .....	RA-20
SERVICE DATA AND SPECIFICATIONS (S.D.S.) .....	RA-22
SPECIAL SERVICE TOOLS .....	RA-25

**RA**

# REAR AXLE AND REAR SUSPENSION

## Wheel alignment

- Camber cannot be adjusted.
  - Vehicle requires only toe-in adjustment.  
-1.5 to 2.5 mm (-0.059 to 0.098 in), -8' to 14' (Total toe-in)
- Refer to section MA for checking wheel alignment.

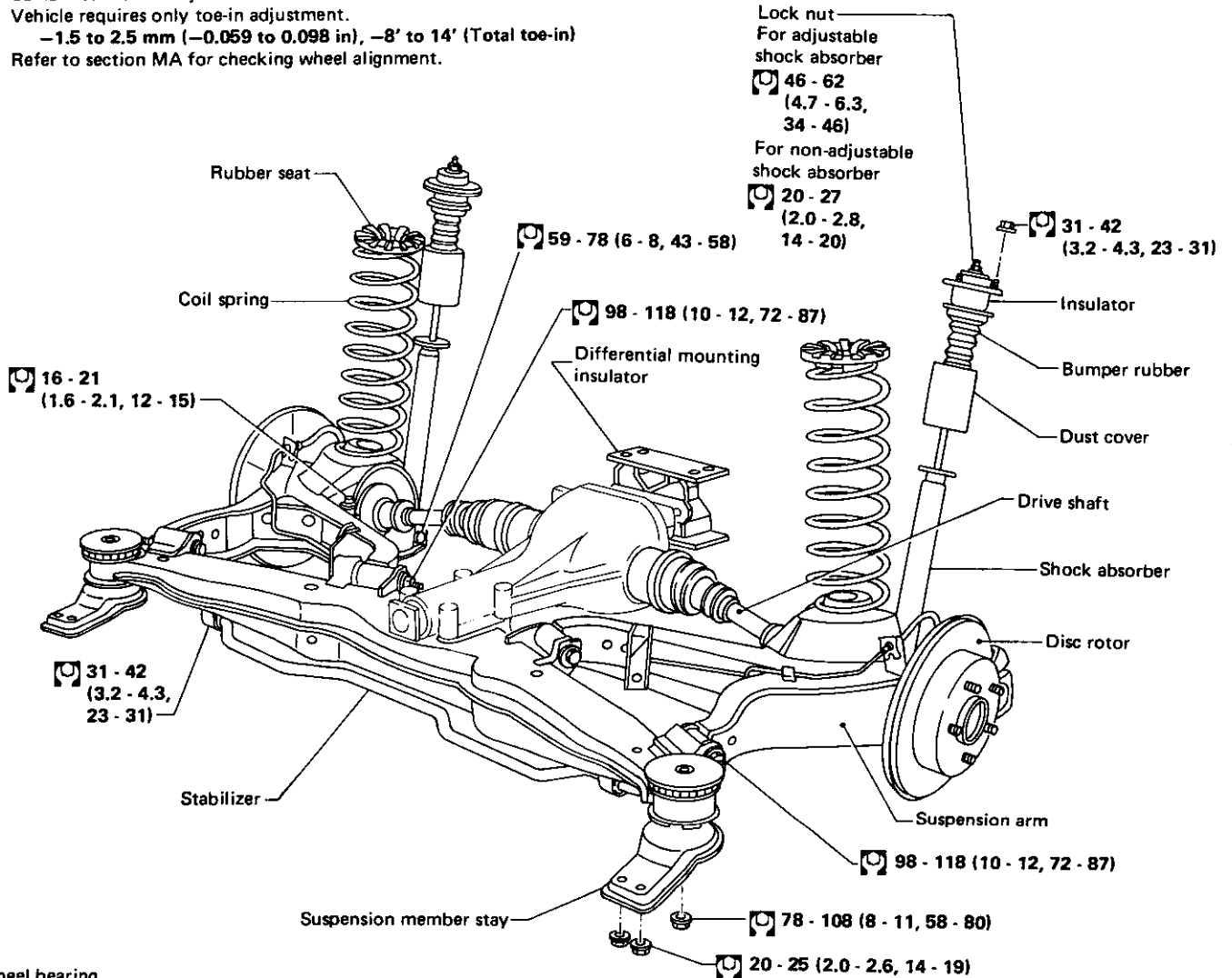

## Wheel bearing

- Axle shaft end play: 0.3 mm (0.012 in) or less
- Bearing preload: 0.7 N·m (7 kg-cm, 6.1 in-lb) or less  
At hub bolt: 12.06 N (1.23 kg, 2.71 lb) or less

: N·m (kg-m, ft-lb)

SRA788

# REAR AXLE AND REAR SUSPENSION

## Removal and Installation

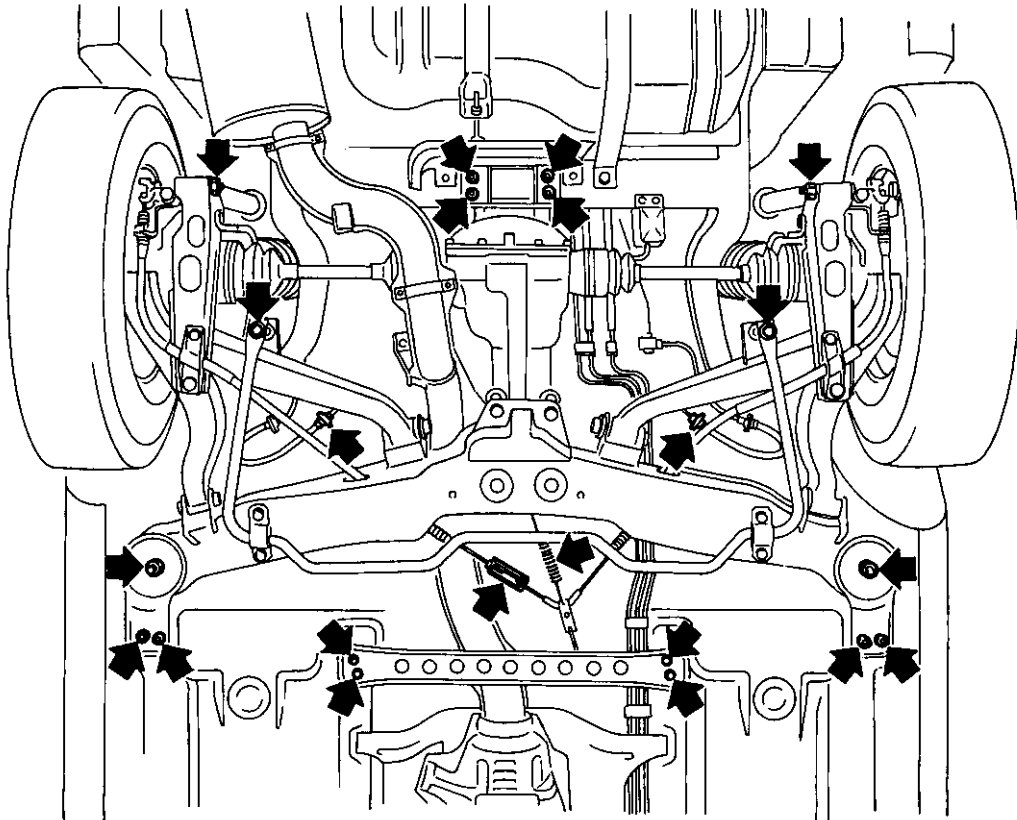

● : Removing and installing points

SRA442

- Disconnect brake hydraulic line and parking brake cable.

### CAUTION:

When removing or installing brake tubes, use Tool.

 15 - 18 N·m  
(1.5 - 1.8 kg-m, 11 - 13 ft-lb)

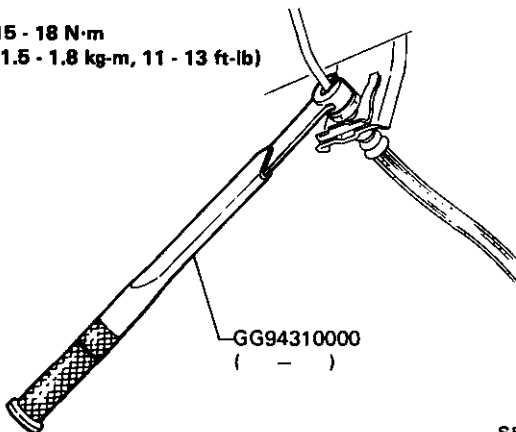

SBR500

- Remove stabilizer fixing bolt.
- Remove rear exhaust tube (Refer to Section FE for removal).
- Remove propeller shaft (Refer to Section PD for removal).

# REAR AXLE—Axle Shaft

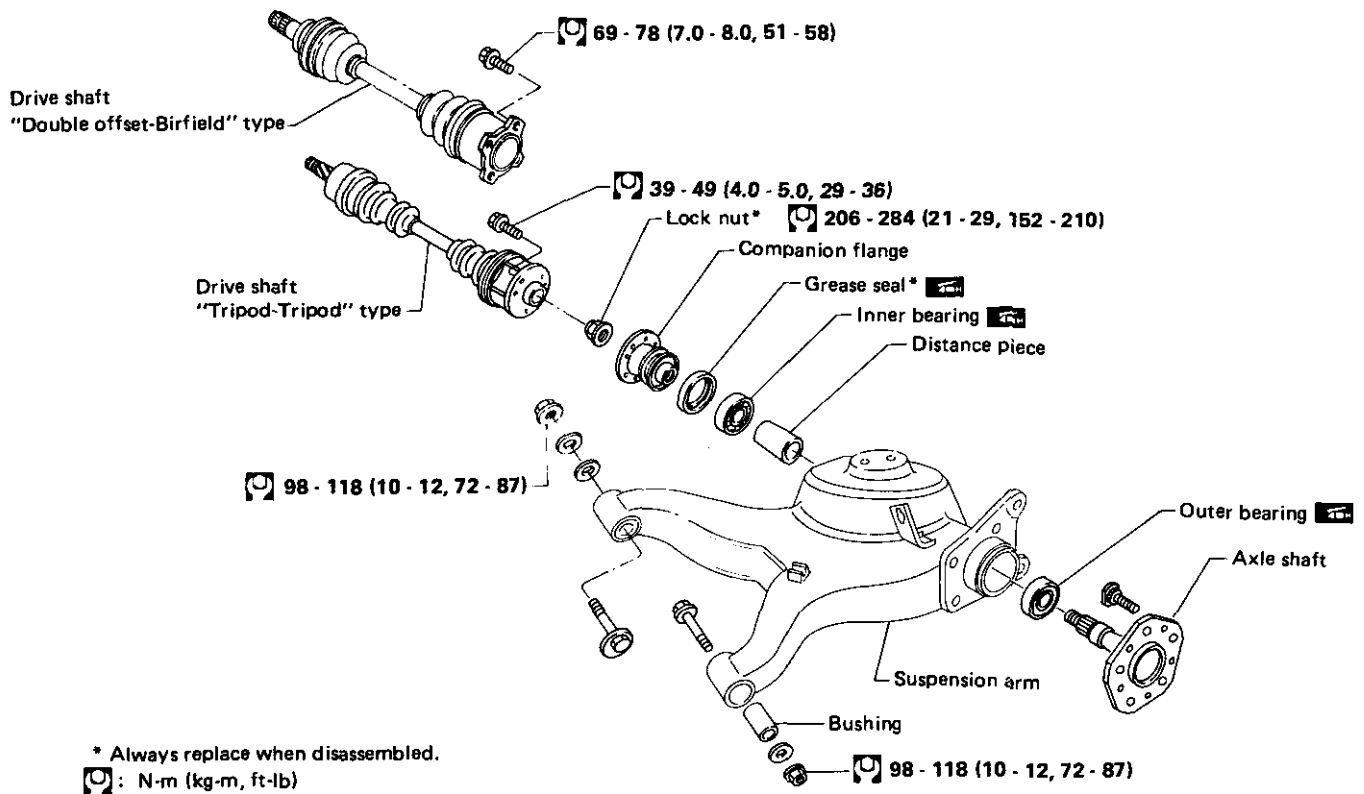

SRA959

## Removal

- Disconnect drive shaft. Refer to Drive Shaft for removal and installation.
- Remove wheel bearing lock nut with parking brake engaged or brake pedal depressed.
- Remove brake caliper and rotor. Refer to Section BR.
- Draw out rear axle shaft with Tool.

## Inspection

Check rear axle shaft for cracks, wear or deformation. Replace if necessary.

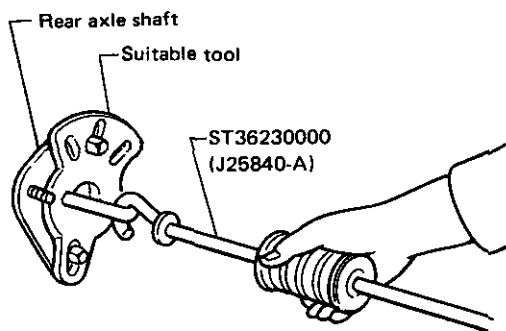

SRA444

# REAR AXLE—Axle Shaft

## Installation

- Wheel bearings are sealed type. When installing, make sure that the sealed side of outer bearing faces the axle shaft flange and that the sealed side of inner bearing faces the companion flange.
- Select a distance piece according to the chart below.

Bearing housing (Suspension arm)	Distance piece	Dimension of distance piece mm (in)
A	A	55.82 - 55.88 (2.1976 - 2.2000)
No mark	B	55.92 - 55.98 (2.2016 - 2.2039)
C	C	56.02 - 56.08 (2.2055 - 2.2079)

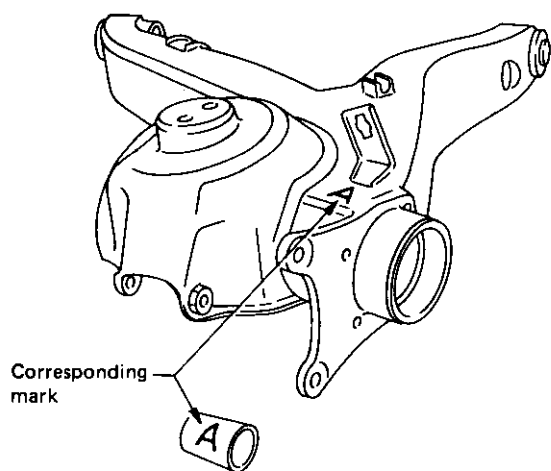

SRA445

When a distance piece is reused, make sure that both ends are not collapsed or deformed.

When installing, make sure that larger side faces axle shaft flange.

- Fill recommended multi-purpose grease to the portions indicated below.

### CAUTION:

Keep grease away from lock nut thread portion and seating surface.

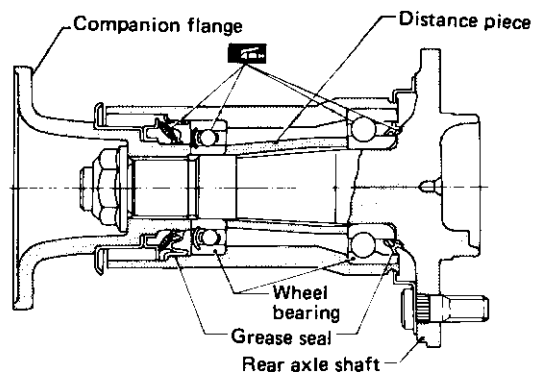

SRA885

- Measure rear wheel bearing preload after installing rear axle shaft.

### Rear wheel bearing preload:

Less than 0.7 N·m (7 kg-cm, 6.1 in-lb)

### At hub bolt:

Less than 12.06 N (1.23 kg, 2.71 lb)

# DRIVE SHAFT

## Removal and Installation

- Remove spring seat stay.
- Extract drive shaft from differential carrier by prying it with a suitable steel bar.

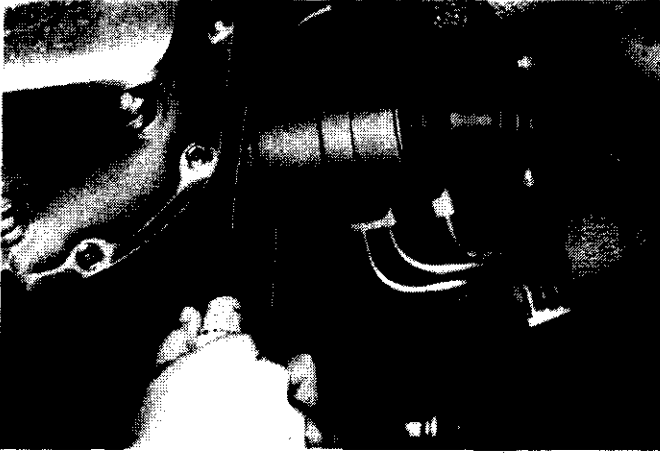

**CAUTION:**

Be careful not to damage oil seal of differential carrier.

# DRIVE SHAFT—"Tripod-Tripod" Type

**Circular clip:**

Make sure circular clip is properly meshed with side gear and will not come out.

**Drive shaft joint:**

Use NISSAN GENUINE GREASE or equivalent after every overhaul.

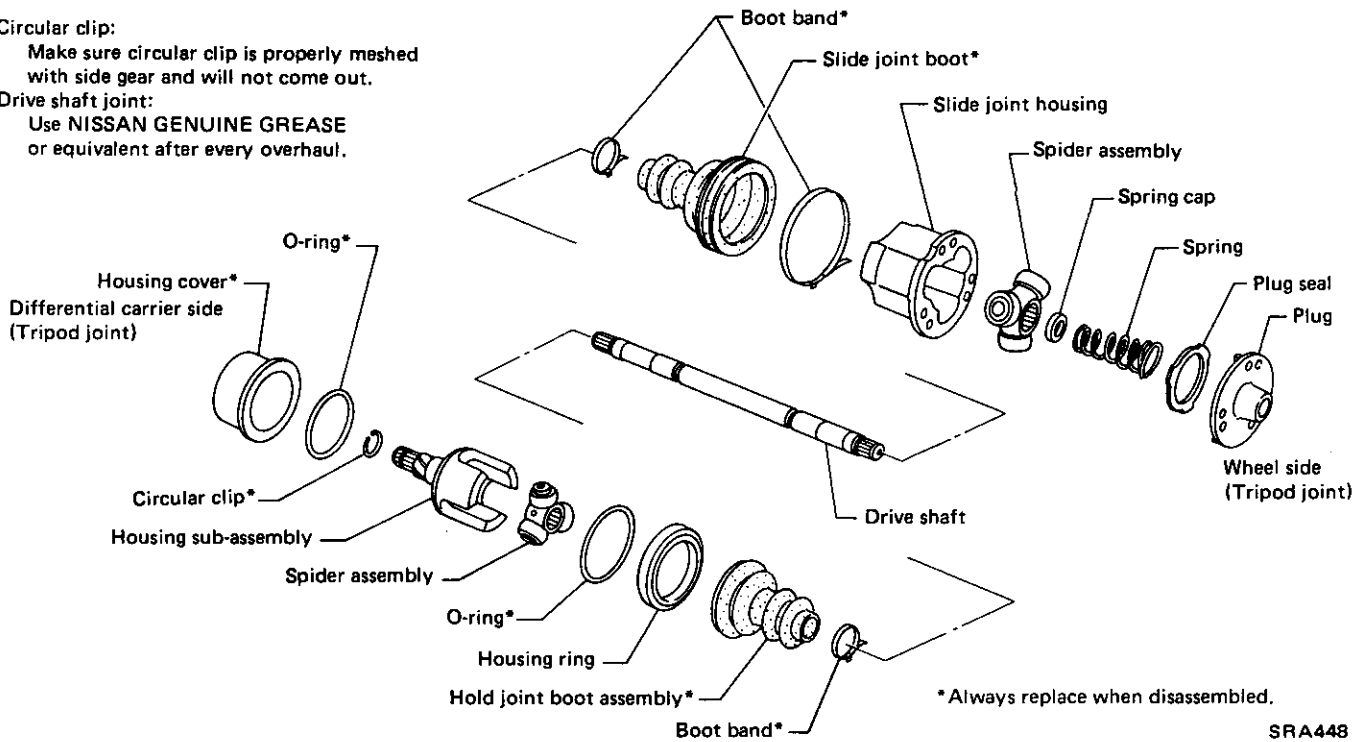

SRA448

## Disassembly

### WHEEL SIDE

Remove plug and boot bands.

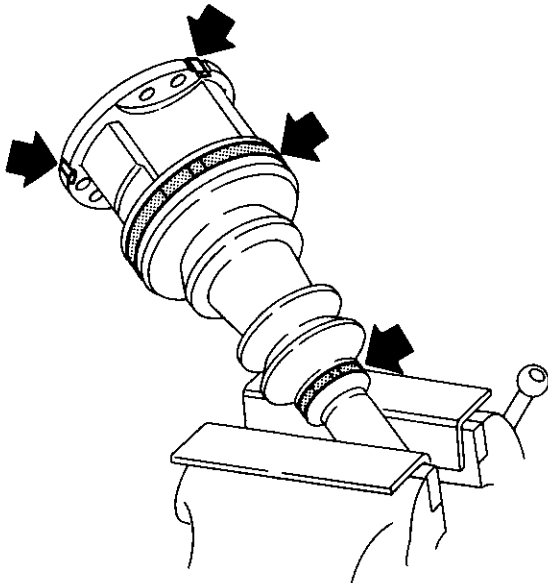

SRA450

### DIFFERENTIAL CARRIER SIDE

- Place drive shaft assembly in a vise.
  - Be careful not to damage drive shaft assembly.
  - Cut off hold joint boot assembly with a metal saw blade and remove housing sub-assembly.
- When cutting, ensure that drive shaft is pushed into housing sub-assembly to prevent spider assembly from being scratched.

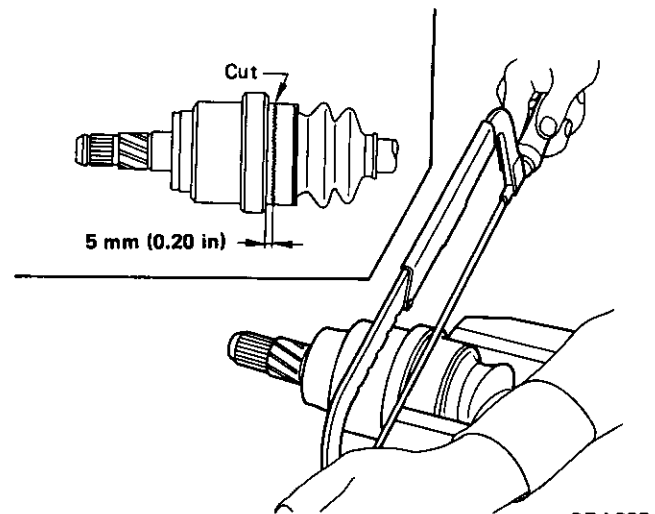

SRA337

# DRIVE SHAFT—"Tripod-Tripod" Type

## Disassembly (Cont'd)

- Remove spider assembly. Refer to WHEEL SIDE.
- Cut off remaining part of hold joint boot assembly with a metal saw blade and remove housing ring.

Be careful not to scratch housing sub-assembly and housing ring.

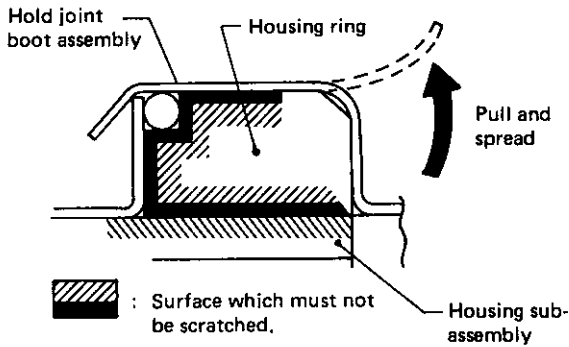

SRA451

- Remove spider assembly.

### CAUTION:

Do not disassemble spider assembly.

- 1) Inscribe matching mark as shown below.

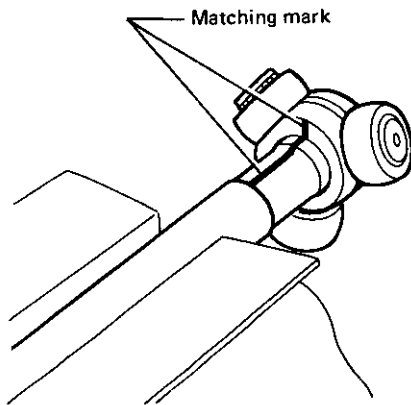

SFA391

- 2) Detach spider assembly with press.

Do not attempt to directly touch contact surface of drive shaft end. Use a suitable tool.

Be careful not to drop drive shaft.

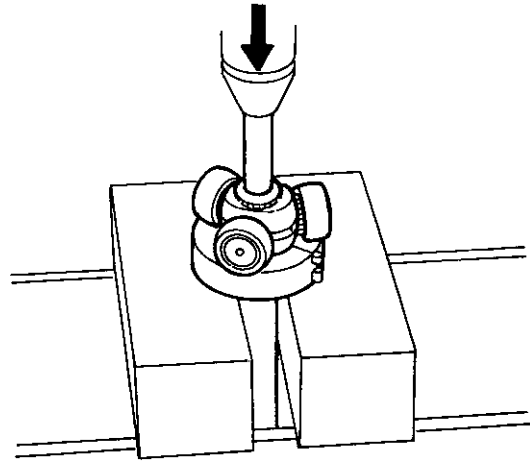

SFA392



# DRIVE SHAFT—"Tripod-Tripod" Type

## Inspection

### DRIVE SHAFT

Check for cracks or other damage. Replace if necessary.

### TRIPOD JOINT

- Check spider assembly for bearing and washer damage. Replace spider assembly if necessary.
- Check slide joint housing and housing sub-assembly for any damage. Replace if necessary.

## Assembly

- Ensure that drive shaft moves smoothly over its entire range without binding after assembling.
- Use **NISSAN GENUINE GREASE** or equivalent after every overhaul.

### WHEEL SIDE

Be careful not to scratch boot with drive shaft serration.

Install spider assembly.

- 1) Place drive shaft in a vise with soft cushioning pads.

- 2) Install spider assembly, ensuring marks are properly aligned.

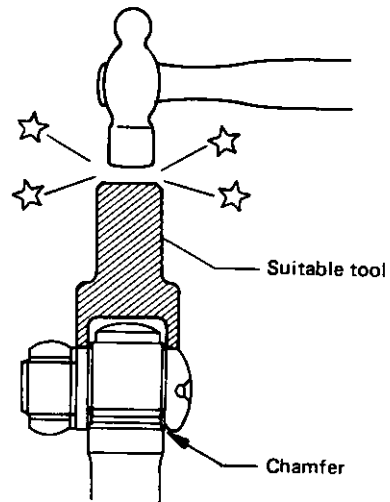

SFA397

- 3) Stake serration portion evenly at three places. Avoid areas which have been previously staked. Always stake two or three teeth at each place.

Stake more than 1 mm (0.04 in)

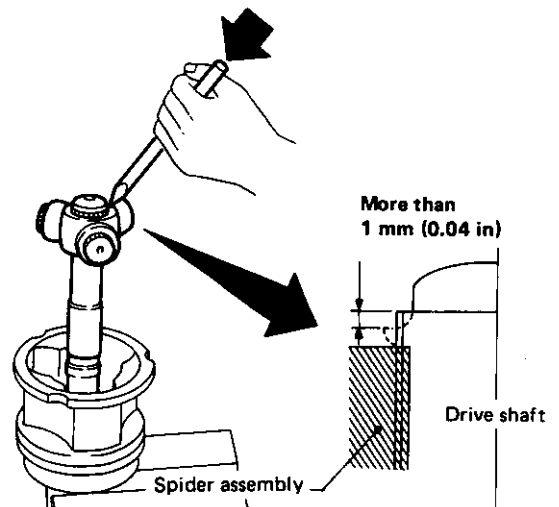

SFA422

# DRIVE SHAFT—"Tripod-Tripod" Type

## Assembly (Cont'd)

- Install hold joint boot assembly.

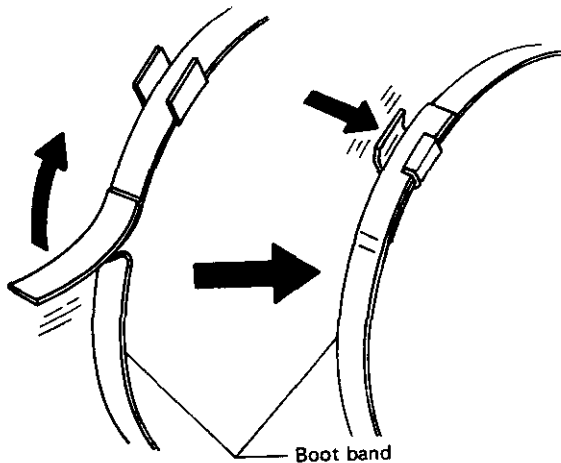

SFA395

- Pack with grease.

Specified amount of grease:

185 - 195 g (6.52 - 6.88 oz)

- Set boot so that it does not swell or deform when its length is "L".

Length "L": 111.5 mm (4.39 in)

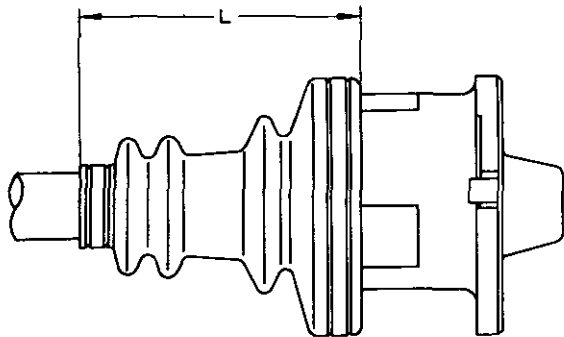

SRA452

### DIFFERENTIAL CARRIER SIDE

#### CAUTION:

When replacing housing ring or housing sub-assembly, always replace them as a set.

- Bend the edge over along the entire circumference.

Bend the edge at two positions (180° apart) and ensure that housing cover does not rattle.

Place a board on housing cover so as not to damage it.

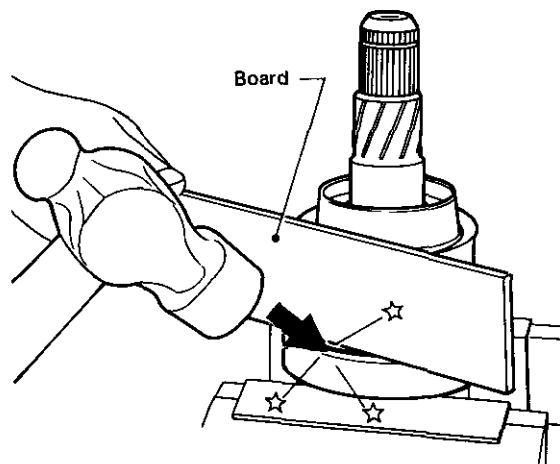

SRA340

- Install new boot band and hold joint boot assembly on drive shaft.

Be careful not to scratch boot with serration of drive shaft.

- Install spider assembly. Refer to WHEEL SIDE.
- Pack with grease.

Specified amount of grease:

155 - 165 g (5.47 - 5.82 oz)

- Place hold joint boot assembly so that its flange is in vise.

Do not place any other part of hold joint boot assembly on a vise.

- Insert housing sub-assembly into hold joint boot assembly.

- Bend the edge over along the entire circumference.

# DRIVE SHAFT—"Tripod-Tripod" Type

## Assembly (Cont'd)

Bend the edge at two positions (180° apart) and ensure that housing sub-assembly does not rattle. Place a board on housing sub-assembly so as not to damage it.

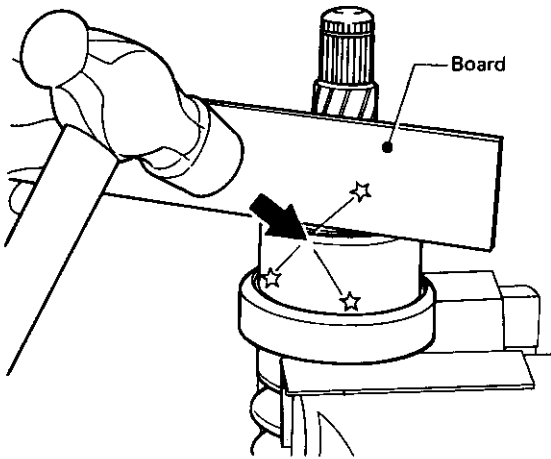

SRA341

- Apply sealant.

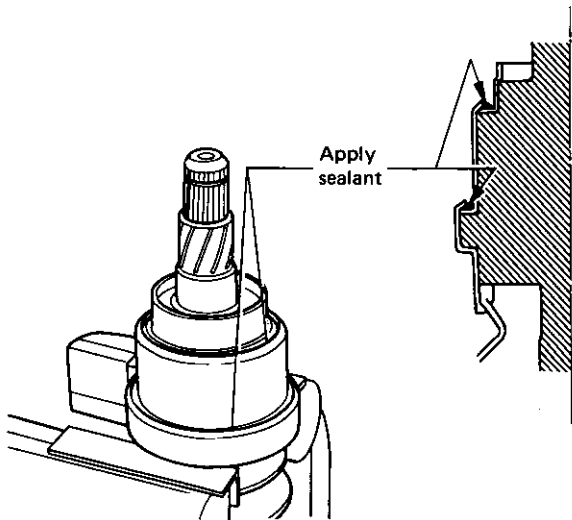

SRA342

- Set boot so that it does not swell or deform when its length is "L".

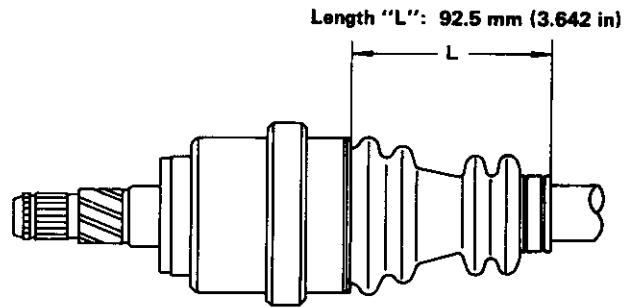

SRA453

# DRIVE SHAFT—"Double Offset-Birfield" Type

## Circular clip:

Make sure circular clip "A" is properly meshed with side gear and that circular clip "B" is also meshed with joint assembly, and will not come out.

## Drive shaft joint:

Use NISSAN GENUINE GREASE or equivalent after every overhaul.

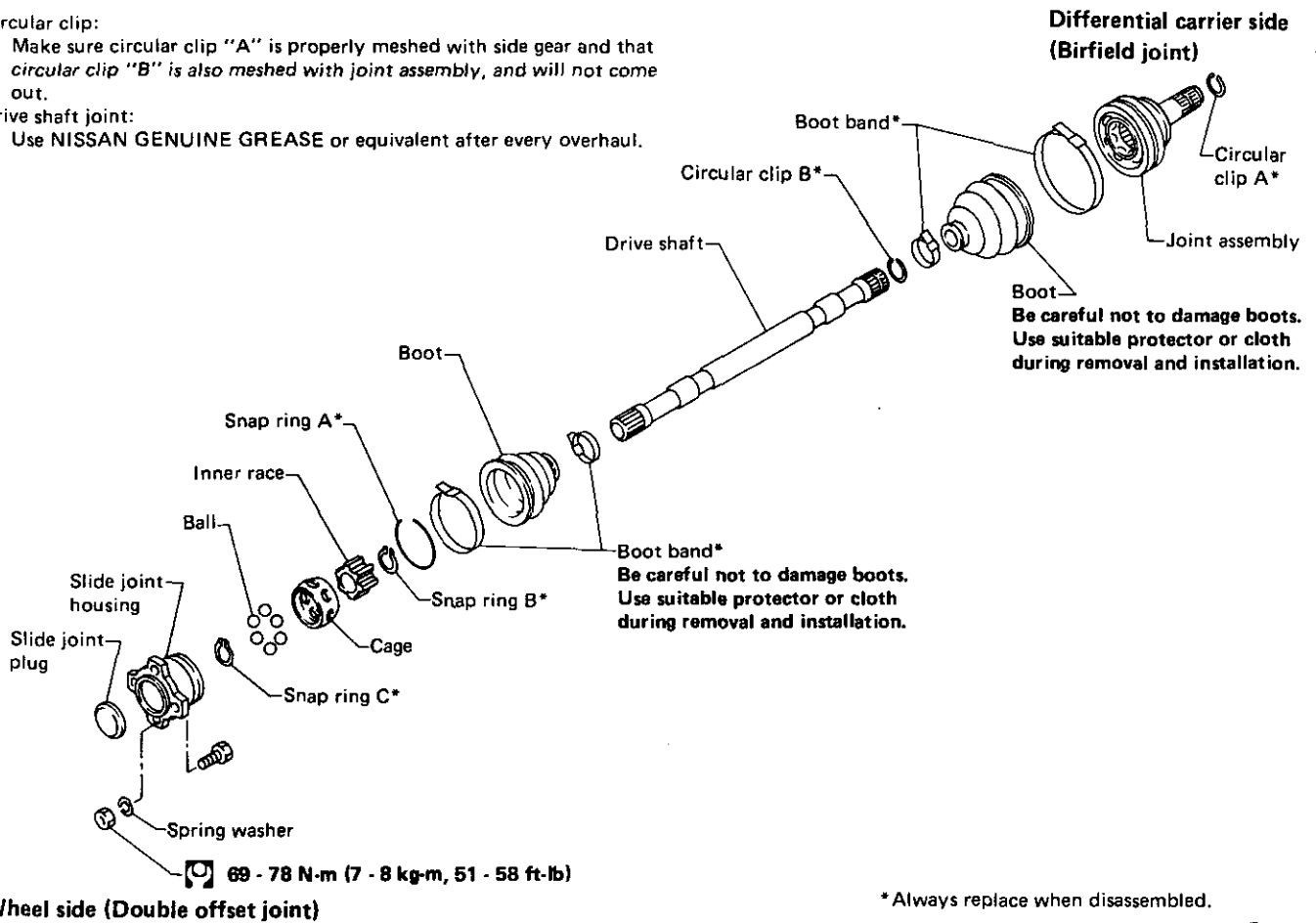

\*Always replace when disassembled.

SFA562

## Disassembly

### DIFFERENTIAL CARRIER SIDE

— Joint —

#### CAUTION:

The joint on the differential carrier side employs a nondisassembling design.

- Before separating joint assembly, put matching marks on drive shaft and joint assembly.
- Separate joint assembly by lightly tapping it. (Use new joint assembly if it is damaged.)

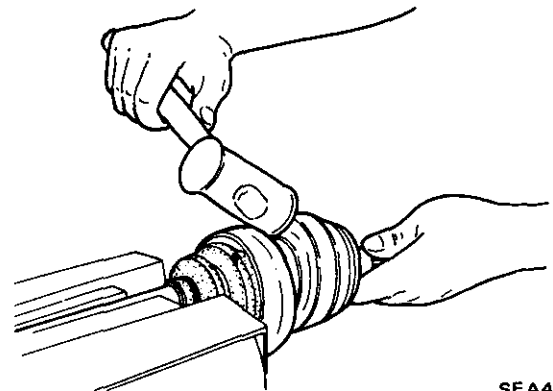

SFA455

# DRIVE SHAFT—"Double Offset-Birfield" Type

## Disassembly (Cont'd)

## Inspection

### — Boot —

When replacing only boot, draw it to the double offset joint side after disassembling the double offset joint. Refer to Wheel side for disassembly.

### WHEEL SIDE

1. Remove boot bands.
2. Put matching marks on slide joint housing and inner race, before separating joint assembly.
3. Pry off snap ring "A" with a screwdriver, and pull out slide joint housing.

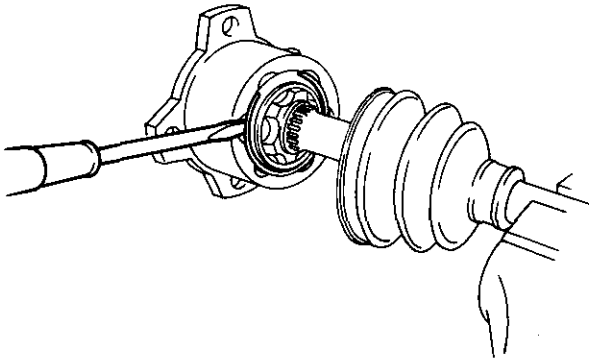

SRA563

4. Put matching marks on inner race and drive shaft.
5. Pry off snap ring "C", then remove ball cage, inner race and balls as a unit.

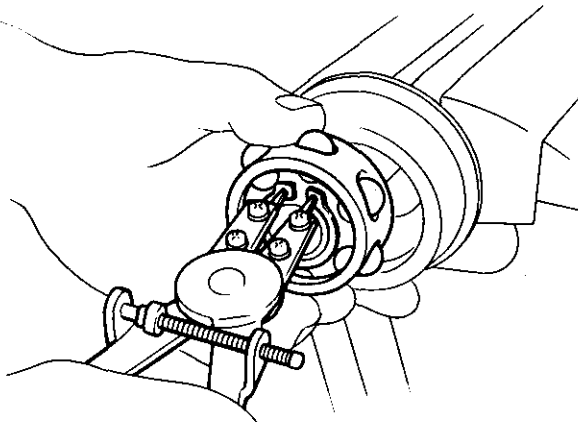

SFA701

6. Pry off snap ring "B".
7. Draw out boot.

### DRIVE SHAFT

Replace drive shaft if it is twisted or cracked.

### JOINT ASSEMBLY (Wheel side)

Check joint assembly for burns, rust, wear or excessive play. Replace if necessary.

Check groove of slide joint housing for cracks, wear or deformation. Replace if necessary.

### JOINT ASSEMBLY (Transaxle side)

Replace joint assembly if it is deformed or damaged.

### BOOT

Replace the boot if it is fatigued, cracked or worn.

## Assembly

- After drive shaft has been assembled, ensure that it moves smoothly over its entire range without binding.
- Use NISSAN GENUINE GREASE or equivalent after every overhaul.

### DIFFERENTIAL CARRIER SIDE

#### Boot

When installing only boot, install it sliding from wheel side.

#### Joint

1. Install boot and new small boot band to drive shaft.

Be careful not to damage boot on the edge of drive shaft.

# DRIVE SHAFT—"Double Offset-Birfield" Type

## Assembly (Cont'd)

2. Set joint assembly onto drive shaft (with new circular clip) by lightly tapping it.

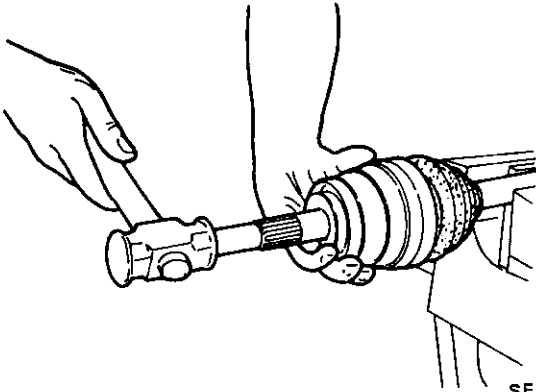

Install joint assembly, ensuring matching marks are properly aligned.

3. Pack drive shaft with specified amount of grease.

**Specified amount:**

**115 - 155 g (4.06 - 5.47 oz)**

- Lock band securely with a suitable tool.

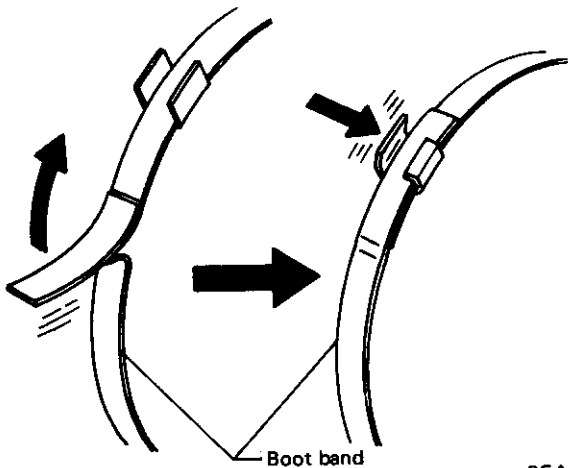
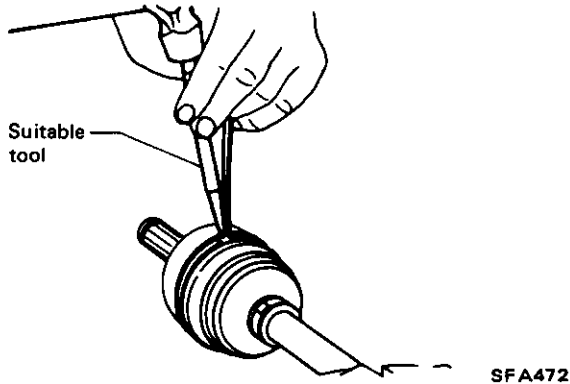

4. Set boot so that it does not swell and deform when its length is "L".

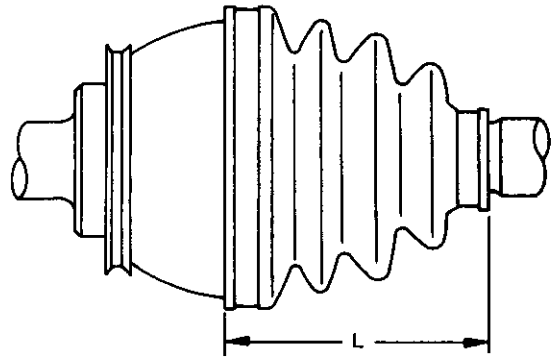

Length "L": 90.8 mm (3.575 in)

SFA725

5. Lock new smaller diameter boot band.

### WHEEL SIDE

- Pack with grease.

**Specified amount of grease:**

**115 - 155 g (4.06 - 5.47 oz)**

- Fasten boot bands.

Refer to Differential carrier side" joint.

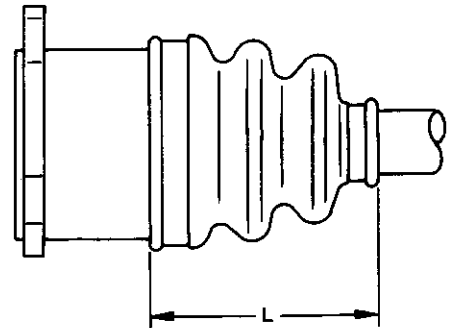

Length "L": 90.4 mm (3.559 in)

SRA564

# REAR SUSPENSION

Final tightening requires to be carried out with tires on ground.

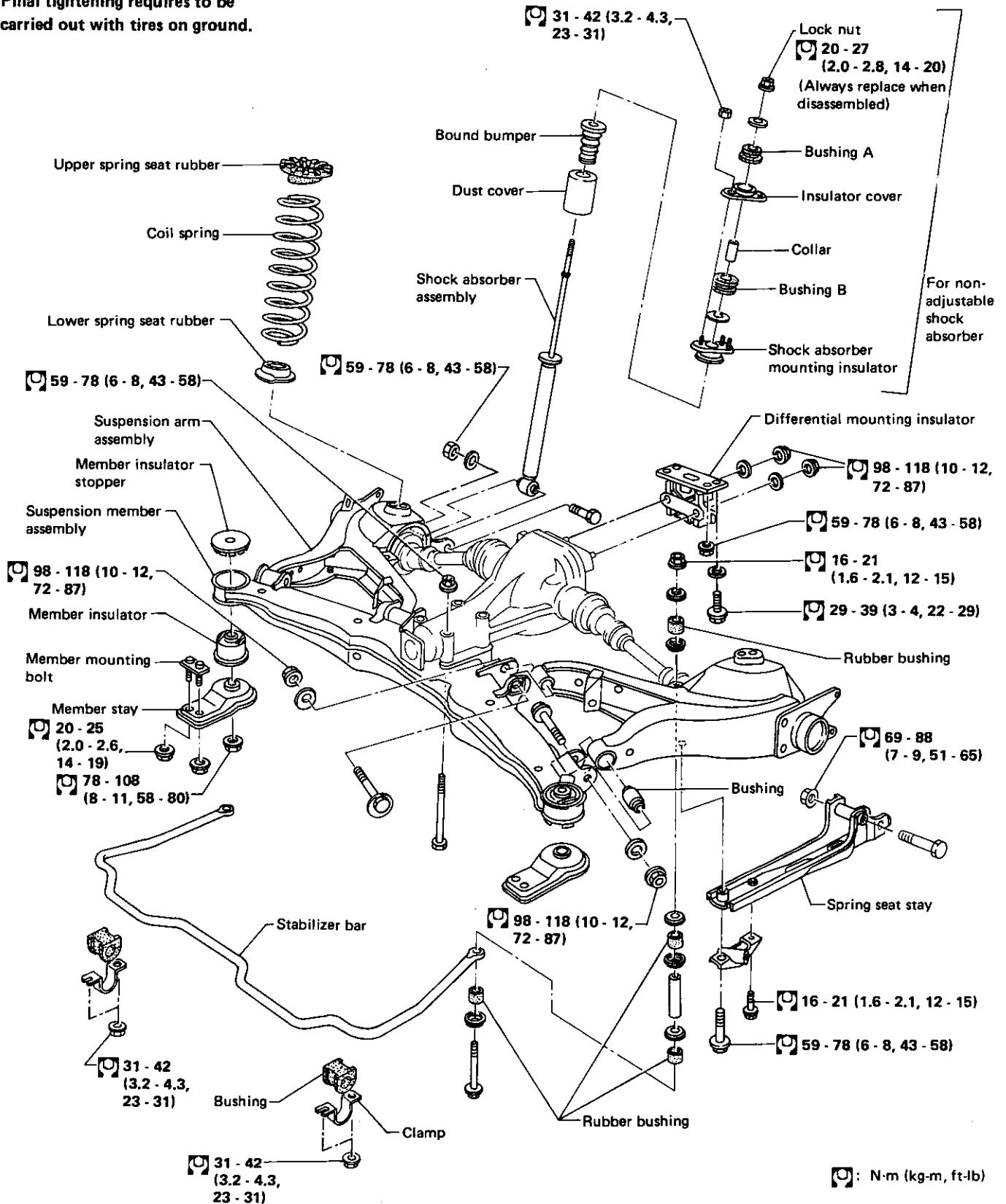

SRA769

# REAR SUSPENSION

## Stabilizer Bar

### REMOVAL AND INSTALLATION

- Remove stabilizer bar.

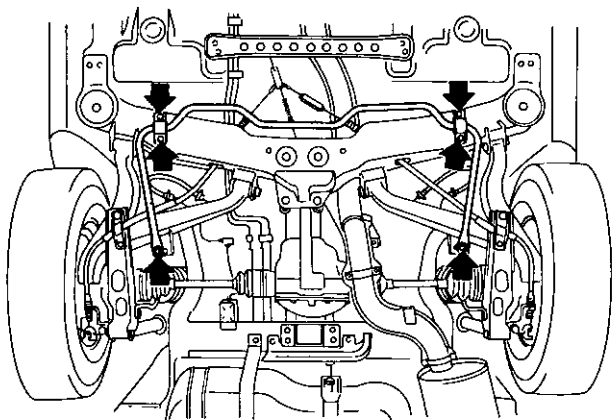

SRA458

- Final tightening requires to be carried out at curb weight with tires on ground.

### INSPECTION

- Check stabilizer bar for deformation or cracks. Replace if necessary.
- Check rubber bushings for deterioration or cracks. Replace if necessary.

## Shock Absorber (Non-adjustable type)

### REMOVAL AND INSTALLATION

- Remove upper end nut of shock absorber.

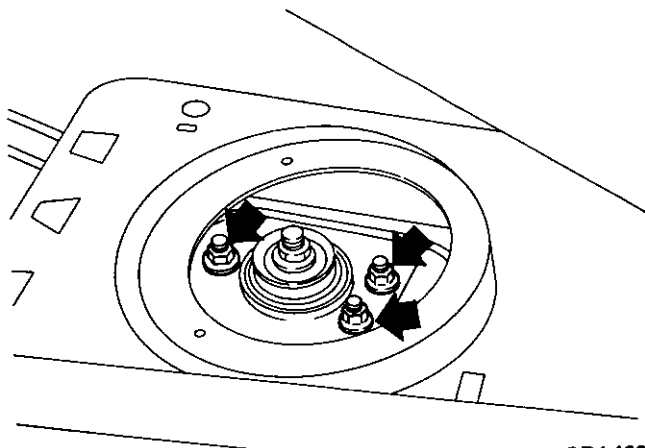

SRA460

- Disconnect shock absorber lower end.

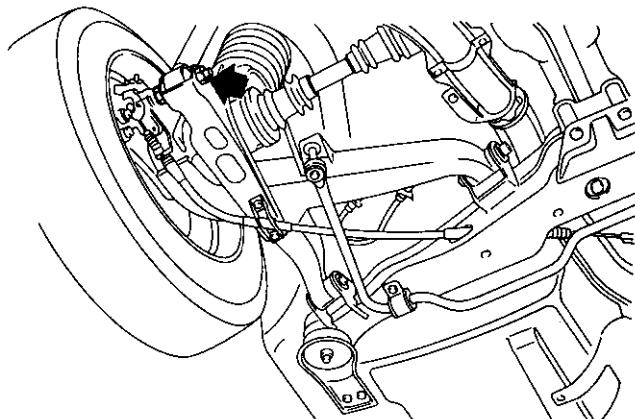

SRA459

- Final tightening requires to be carried out at curb weight with tires on ground.

### INSPECTION

- Check all rubber parts for wear, cracks, deformation or other damage. Replace if necessary.
- If oil leakage occurs, replace shock absorber assembly.
- Check threads for cracks or other damage. Replace if necessary.
- Check piston rod for cracks, deformation or other damage. Replace shock absorber assembly if necessary.

### ASSEMBLY

Cover piston rod with tape so as not to damage it when tightening lock nut.

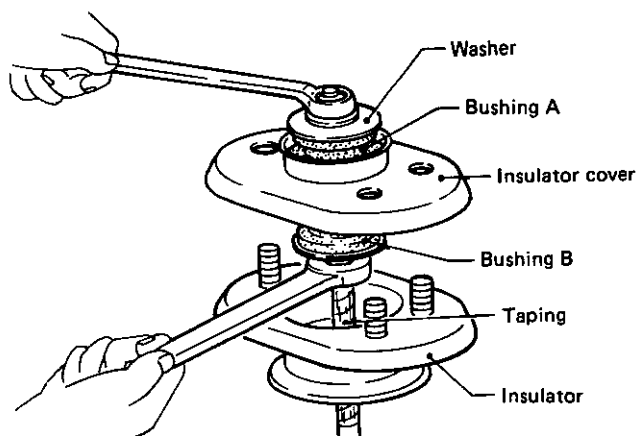

SRA461



# REAR SUSPENSION

## Coil Spring

### REMOVAL AND INSTALLATION

- Jack up vehicle after setting spring compressor. Then remove coil spring.
- When installing, correctly place coil spring in both spring seat rubbers. (Flat face of spring is on top.)

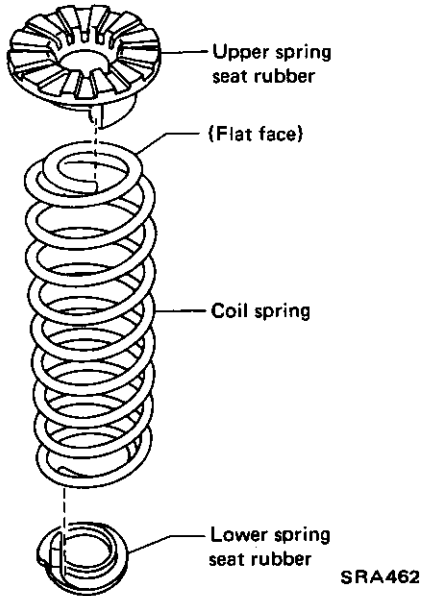

### INSPECTION

- Check coil spring for yield, deformation or cracks. Replace if necessary.
- Check upper and lower spring seat rubbers for wear, cracks or damage. Replace if necessary.

## Suspension Arm

### REMOVAL AND INSTALLATION

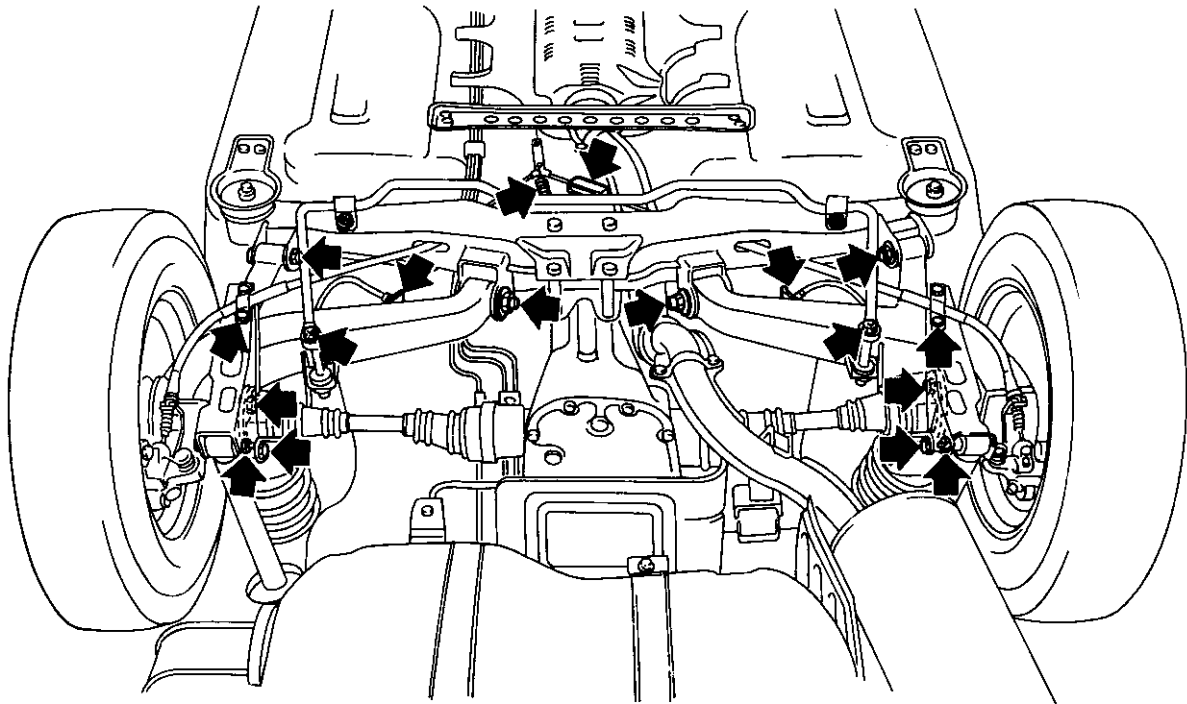

← : Removing and installing points

SRA770

# REAR SUSPENSION

## Suspension Arm (Cont'd)

- Remove drive shaft from companion flange.
- Remove axle shaft assembly. Refer to Axle Shaft for removal.
- Remove stabilizer bar fixing bolt from rear arm.
- Remove lower end of shock absorber fixing bolt.
- Remove suspension arm pin.

Before removing, put matching mark on pin.

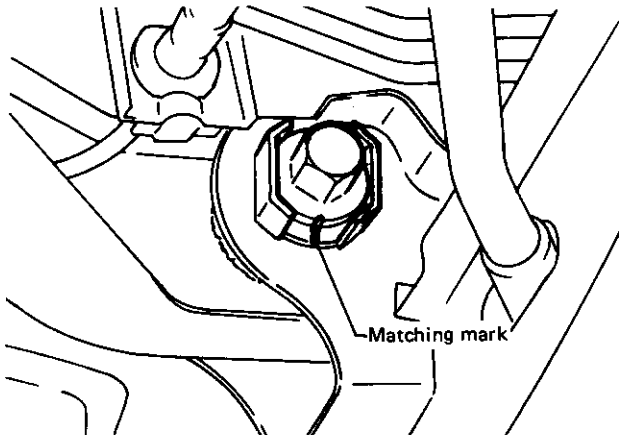

SRA565

- When installing, tighten pin nut of suspension arm to specified torque after installing wheels and placing vehicle on ground under the curb weight.
- Refer to Section MA for toe-in adjustment.

### INSPECTION

- Check suspension arm for deformation or cracks. Replace if necessary.
- Check rubber bushings for wear or other damage.

Replace rubber bushing with a suitable tool if necessary.

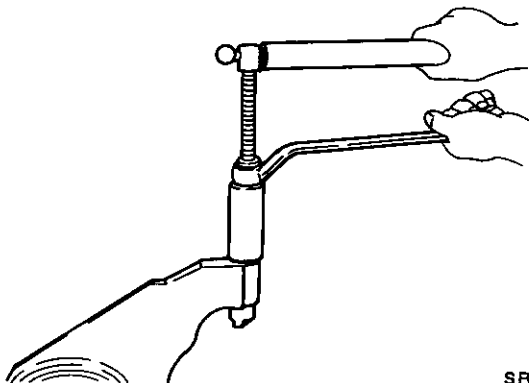

SRA465

## Suspension Member and Differential Mounting Insulator

### INSPECTION

- Check differential mounting insulator for deformation or cracks. Replace if necessary.
  - Check suspension member for deformation or cracks. Replace if necessary.
- a. If member insulator is deformed or cracked, replace it with a suitable tool.

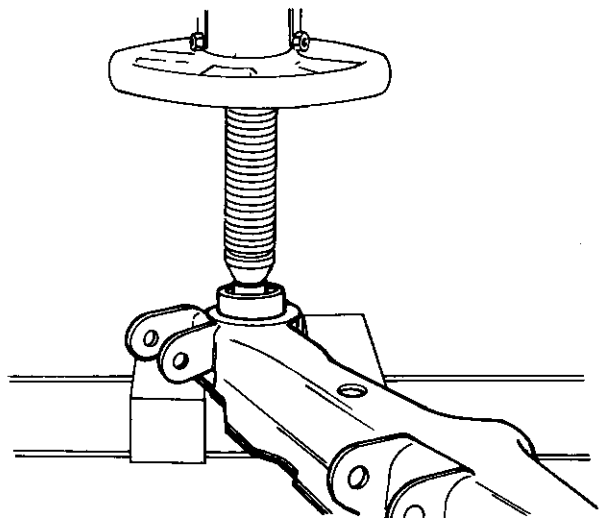

SRA455

- b. Install member insulator with a suitable tool. Be sure to install in its proper place.

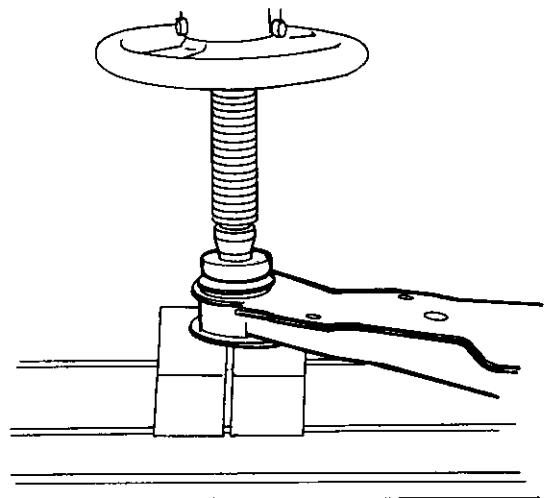

SRA456

# REAR SUSPENSION

## Suspension Member and Differential Mounting Insulator (Cont'd)

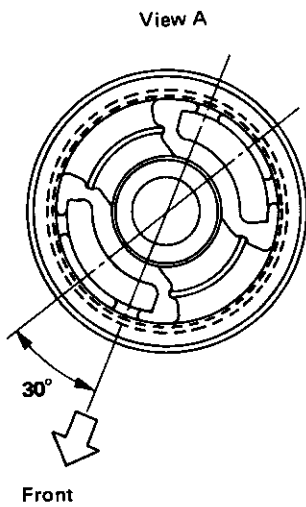
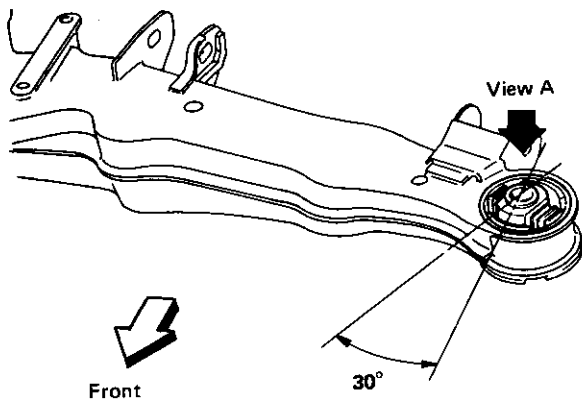

SRA457

# REAR SUSPENSION—Adjustable Shock Absorber

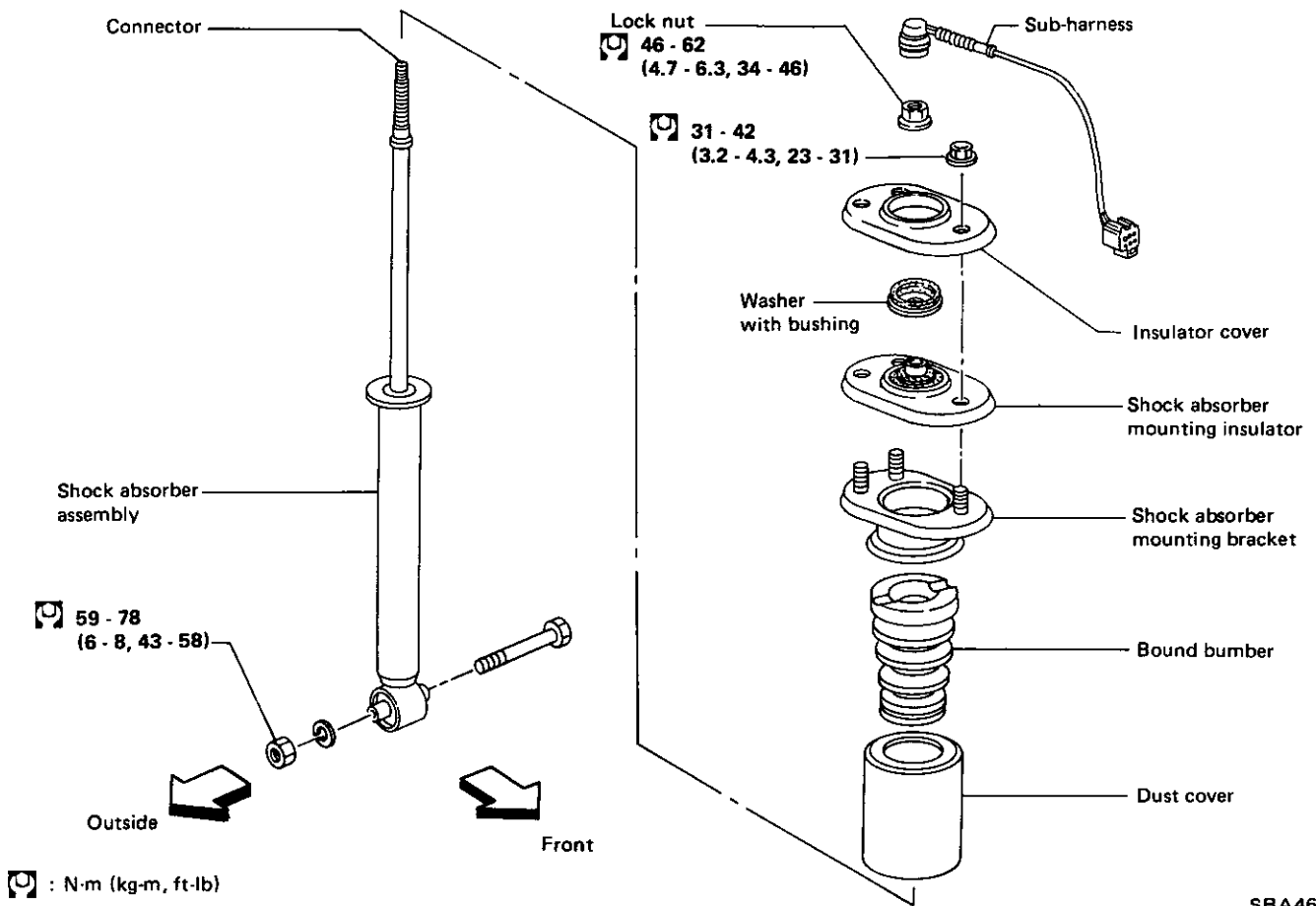

SRA466

## Removal and Installation

- Remove luggage side trim. Then disconnect connector.

Disconnect connector gripping both sides of sub-harness connector.

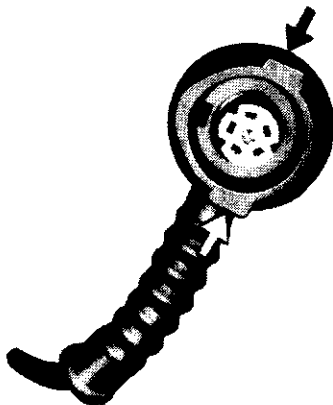

- Remove upper end nut of shock absorber.

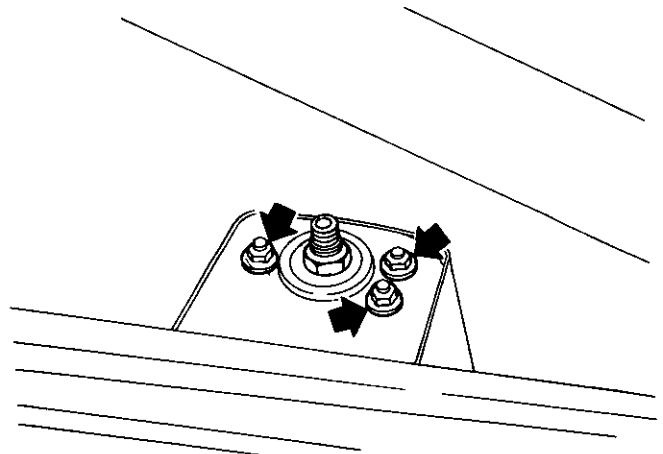

SRA467

- Disconnect lower end nut of shock absorber.

**CAUTION:**

Keep water and dust away from connector.

# REAR SUSPENSION—Adjustable Shock Absorber

## Inspection

Refer to Non-adjustable Shock Absorber.

## Assembly

- Cover piston rod with tape so as not to damage it when assembling.
- Connect sub-harness to connector within piston rod using guide. Be careful not to damage connector.

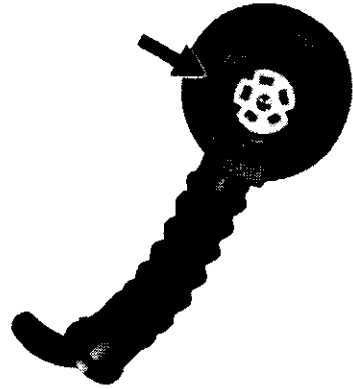

## Trouble Diagnosis

Refer to FRONT AXLE AND FRONT SUSPENSION.

# SERVICE DATA AND SPECIFICATIONS (S.D.S.)

## General Specifications

### SUSPENSION

Item	Engine	VG30ET			VG30E			
	Vehicle model	2 seater		2+2 seater	2 and 2+2 seater			
	Grade	GL	GLL	GL, GLL	SF, GL		GLL	
	Roof	T-roof			Standard	T-roof		
Suspension type	Semi-trailing arm type independent rear suspension							
Coil spring								
Wire diameter	mm (in)	13.8 (0.543)			13.0 (0.512)	13.2 (0.520)	13.3 (0.524)	
Coil diameter	mm (in)	111.8 (4.40)			111.0 (4.37)	111.2 (4.38)	111.3 (4.38)	
Free length	mm (in)	336.5 (13.25)	341.0 (13.43)		376.0 (14.80)	382 (15.04)	388 (15.28)	
Spring constant	N/mm (kg/mm, lb/in)	33.0 (3.36, 188.2)			24.5 (2.5, 140)			
Identification color		Purple x 1 Yellow x 2	Pink x 1 White x 2		White x 1 Yellow x 2	Red x 1 White x 2	Green x 1 Yellow x 2	
Shock absorber	Gas-filled double acting hydraulic							
Type	Adjustable			Non-adjustable				
Piston diameter	mm (in)	32 - 32.1 (1.260 - 1.264)			25 - 25.1 (0.984 - 0.988)			
Piston rod diameter	mm (in)	22 (0.87)			12.5 (0.492)			
Stroke	mm (in)	599.3 (23.59)/384.5 (15.14)			609.3 (23.99)/392.5 (15.45)			
Maximum/Minimum								
Cylinder diameter	mm (in)	48.6 (1.913)			38.1 (1.500)			
Damping force		Firm	Normal	Soft				
[at 0.3 m (1.0 ft)/sec.]								
Expansion	N (kg, lb)	794 - 1,069 (81 - 109, 179 - 240)	549 - 726 (56 - 74, 123 - 163)	363 - 481 (37 - 49, 82 - 108)	588 (60, 132)			
Compression	N (kg, lb)	481 - 637 (49 - 65, 108 - 143)	382 - 500 (39 - 51, 86 - 112)	157 - 216 (16 - 22, 35 - 49)	294 (30, 66)			
Stabilizer tube diameter								
Outer	mm (in)	24 (0.94)			22.2 (0.874)			
Inner	mm (in)	17.0 (0.669)						

# SERVICE DATA AND SPECIFICATIONS (S.D.S.)

## General Specifications (Cont'd)

## Inspection and Adjustment

### DRIVE SHAFT

	Engine	
	VG30E	VG30ET
Model	2T82S	BF90DS90
Joint type		
Differential carrier side	Tripod	Birfield
Wheel side	Tripod	Double offset
Maximum winding degree		
Differential carrier side	18.3°	40°
Wheel side	15°	23°
Length "L" mm (in)		
Maximum [Left/Right]	464.5 (18.29)/ 475.5 (18.72)	449.5 (17.70)/ 461.5 (18.17)
Minimum [Left/Right]	407 (16.02)/ 418 (16.46)	409.5 (16.12)/ 421.5 (16.59)

#### VG30E

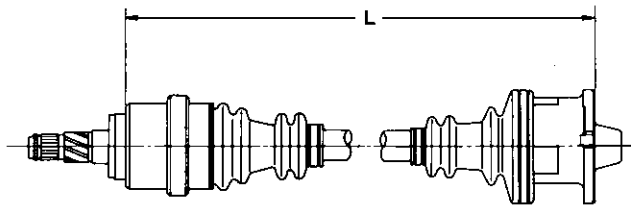

SRA473

#### VG30ET

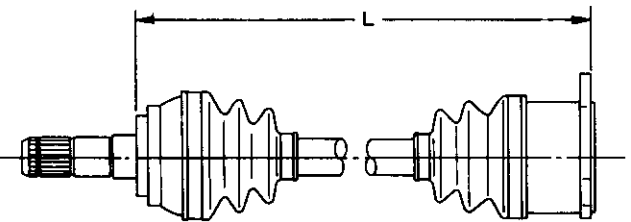

SRA561

Grease		Nissan genuine grease or equivalent	
Name			
Capacity	g (oz)	185 - 195 (6.52 - 6.88)	115 - 155 (4.06 - 5.47)
Wheel side			
Differential carrier side		155 - 165 (5.47 - 5.82)	

### Wheel alignment (Unladen\*1)

Camber	degree	-1°55' to -25'
Toe-in	mm (in)	-1.5 to 2.5 (-0.059 to 0.098)
	degree	-8' to 14' (Total toe-in)

\*1: Tankful of fuel, radiator coolant and engine oil full.  
Spare tire, jack, hand tools, mats in designed position.

### Rear axle shaft

Wheel bearing preload	N·m (kg·cm, in·lb)	0.7 (7, 6.1) or less
Wheel bearing preload at hub bolt	N (kg, lb)	12.06 (1.23, 2.71) or less
Rear axle shaft end play	mm (in)	Less than 0.3 (0.012)
Distance piece length	mm (in)	A 55.82 - 55.88 (2.1976 - 2.2000)
		B 55.92 - 55.98 (2.2016 - 2.2039)
		C 56.02 - 56.08 (2.2055 - 2.2079)

# SERVICE DATA AND SPECIFICATIONS (S.D.S.)

## Tightening Torque

Item	N-m	kg-m	ft-lb
Wheel nut	98 - 118	10 - 12	72 - 87
Three-way connector			
Connector mounting bolt	5 - 7	0.5 - 0.7	3.6 - 5.1
Connector to brake tube	15 - 18	1.5 - 1.8	11 - 13
Brake tube connector flare nut	15 - 18	1.5 - 1.8	11 - 13
Shock absorber			
Lower end fixing bolt	59 - 78	6 - 8	43 - 58
Upper end fixing bolt	31 - 42	3.2 - 4.3	23 - 31
Piston rod self-locking nut			
Adjustable	46 - 62	4.7 - 6.3	34 - 46
Non-adjustable	20 - 27	2.0 - 2.8	14 - 20
Suspension member			
Suspension member to suspension member stay	78 - 108	8 - 11	58 - 80
Suspension member stay to body	20 - 25	2.0 - 2.6	14 - 19
Suspension member to suspension arm	98 - 118	10 - 12	72 - 87
Sprint seat stay			
Stay to suspension arm			
Front	59 - 78	6 - 8	43 - 58
Rear	69 - 88	7 - 9	51 - 65
Stay to parking cable clamp	16 - 21	1.6 - 2.1	12 - 15

Item	N-m	kg-m	ft-lb
Rear disc brake			
Baffle plate fixing bolt	3.2 - 4.3	0.33 - 0.44	2.4 - 3.2
Torque member fixing bolt	38 - 52	3.9 - 5.3	28 - 38
Differential carrier			
Differential carrier to mounting insulator	98 - 118	10 - 12	72 - 87
Mounting bracket to body			
Bolt	29 - 39	3 - 4	22 - 29
Nut	59 - 78	6 - 8	43 - 58
Differential carrier to suspension member	59 - 78	6 - 8	43 - 58
Stabilizer			
Stabilizer bar to suspension arm	16 - 21	1.6 - 2.1	12 - 15
Stabilizer bar clamp to suspension member	31 - 42	3.2 - 4.3	23 - 31
Drive shaft			
Drive shaft to companion flange			
Turbo	69 - 78	7.0 - 8.0	51 - 58
Non-turbo	39 - 49	4.0 - 5.0	29 - 36
Wheel bearing lock nut	206 - 284	21 - 29	152 - 210

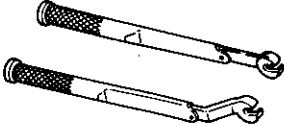

# SPECIAL SERVICE TOOLS

Tool number (Kent-Moore No.)	Tool name
GG94310000 ( - )	Flare nut torque wrench 
ST36230000 (J25840-A)	Slide hammer 