

ENGINE LUBRICATION & COOLING SYSTEMS

SECTION **LC**

LC

CONTENTS

ENGINE LUBRICATION SYSTEM	LC- 2
ENGINE LUBRICATION SYSTEM – For Turbocharged Models	LC- 6
ENGINE COOLING SYSTEM	LC- 7
ENGINE COOLING SYSTEM – For Turbocharged Models	LC-13
SERVICE DATA AND SPECIFICATIONS (S.D.S.)	LC-15
SPECIAL SERVICE TOOLS	LC-17

ENGINE LUBRICATION SYSTEM

Lubrication Circuit

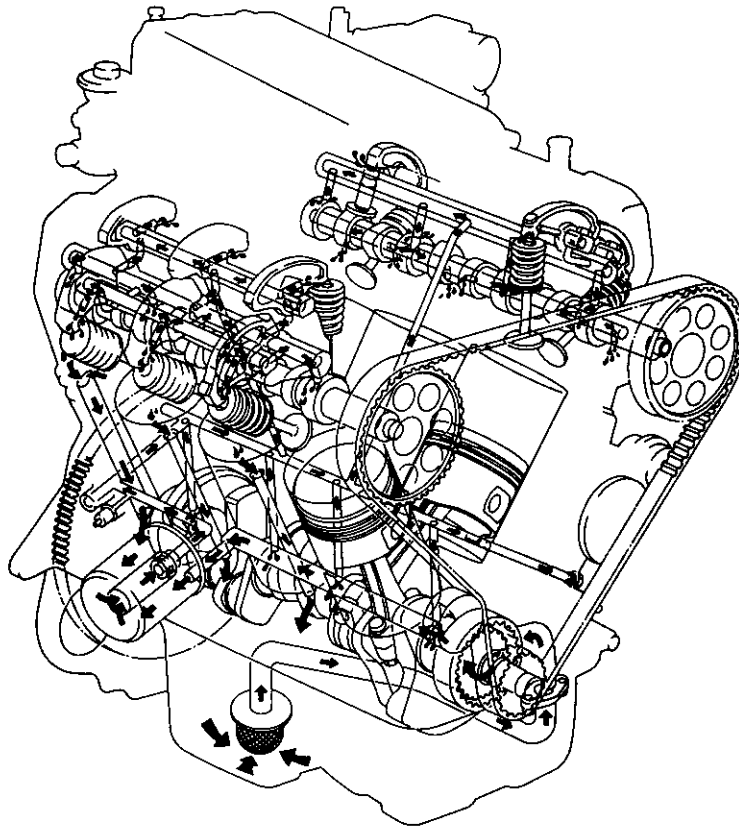

Note:

← : Oil passage

← : Oil gallery in cylinder block

← : By-pass passage

*1: Additional lubrication circuit for turbocharged model

*2: Additional oil cooler for turbo A/T model

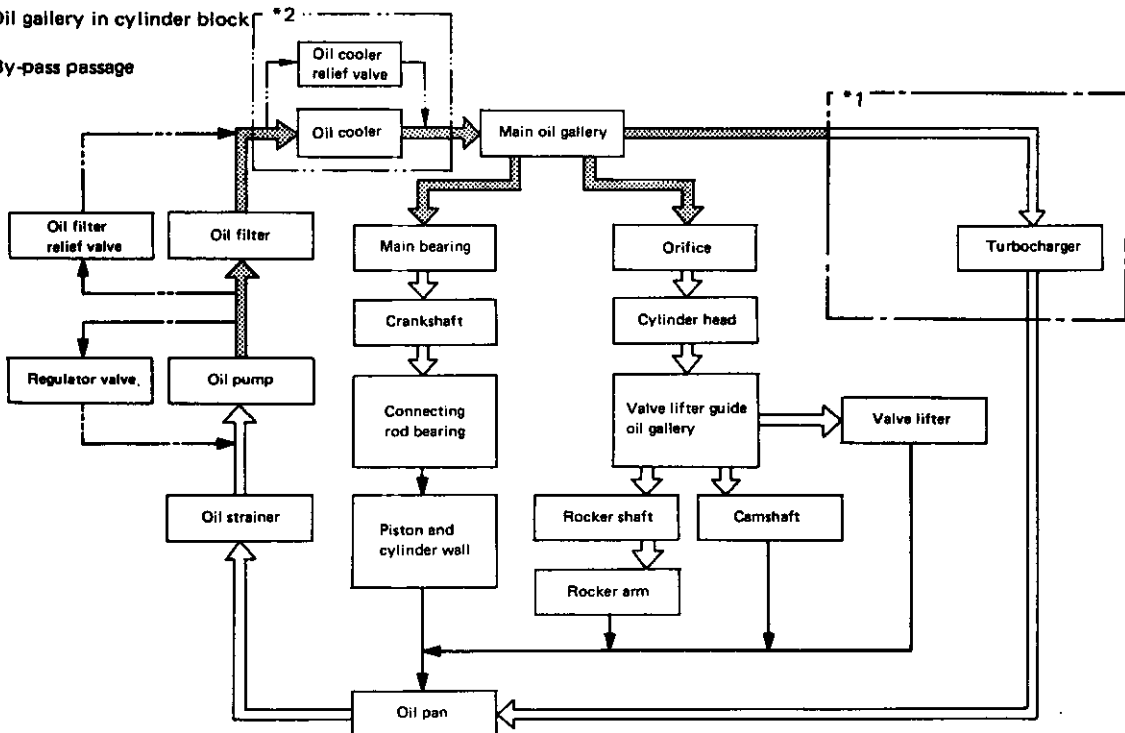

SLC729

ENGINE LUBRICATION SYSTEM

WARNING:

- Be careful not to burn yourself, as the engine and oil may be hot.
- Oil pressure check should be done in "Neutral" gear position.

1. Check oil level.
2. Remove oil pressure switch.

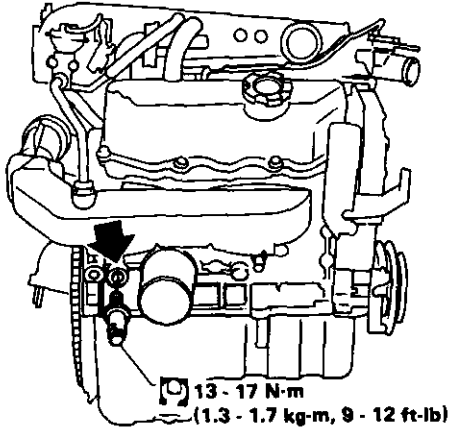

SLC545

3. Install pressure gauge.
4. Start engine and warm it up to normal operating temperature and, then check oil pressure with engine running under no-load.

Engine rpm	Approximate discharge pressure kPa (kg/cm ² , psi)
Idle speed	More than 59 (0.6, 9)
3,200	Non-turbo 363 - 451 (3.7 - 4.6, 53 - 65) Turbo 373 - 432 (3.8 - 4.4, 54 - 63)

If difference is extreme, check oil passage and oil pump for oil leaks.

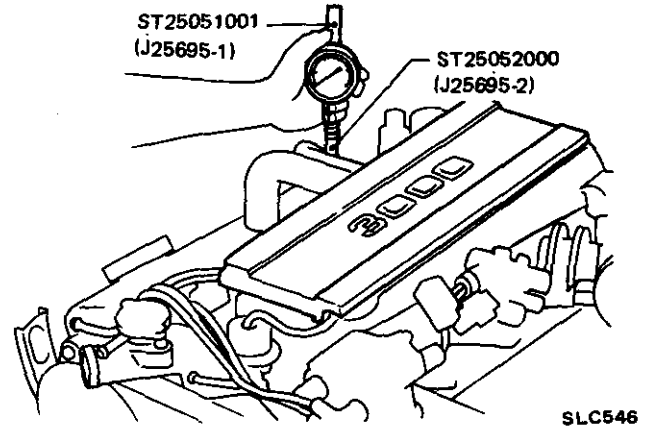

5. Install oil pressure switch.

Use proper liquid sealant.

⚙️ : 13 - 17 N·m (1.3 - 1.7 kg·m, 9 - 12 ft·lb)

ENGINE LUBRICATION SYSTEM

Oil Pump Disassembly and Assembly

1. Drain oil.
2. Remove oil pan.
In case of on-vehicle service, refer to Oil Pan for removal in section EM.
3. Remove oil pump assembly.

When installing oil pump, apply engine oil to inner and outer gear.

Be sure that O-ring is properly fitted on.

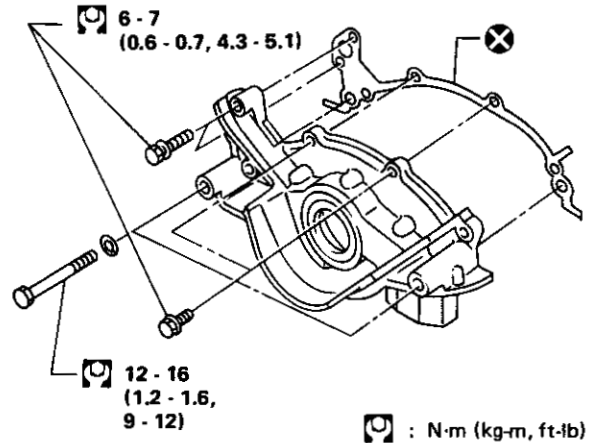

SLC936

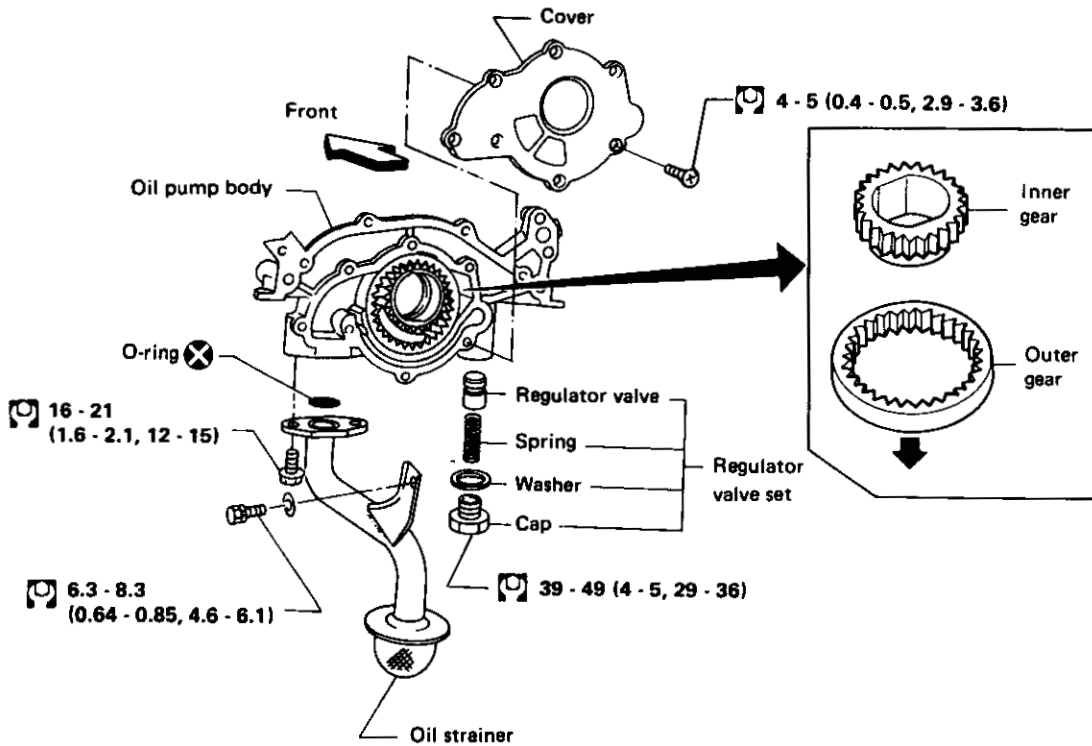

⊗ : N·m (kg·m, ft·lb)

SLC759

ENGINE LUBRICATION SYSTEM

Oil Pump Inspection

1. Visually inspect components for wear and damage.
2. Check oil pressure regulator valve sliding surface and valve spring.

If damaged, replace as a valve set.

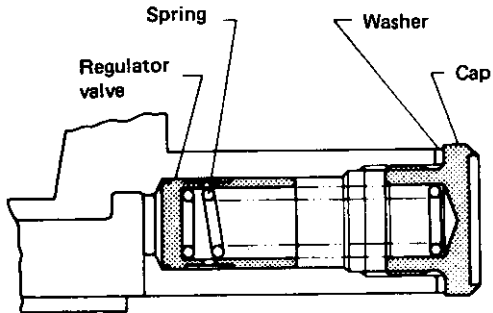

SLC295

3. Using a feeler gauge, check the following clearance.

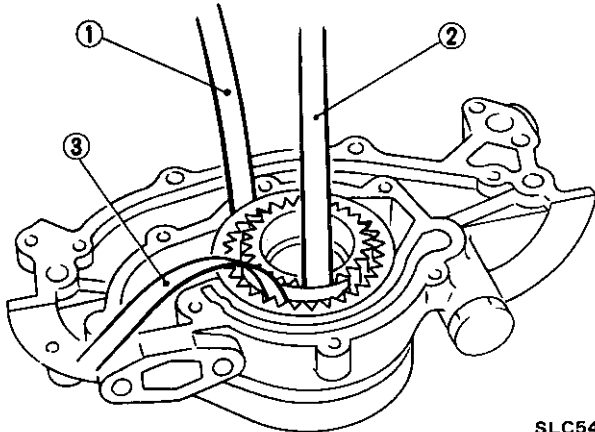

SLC549

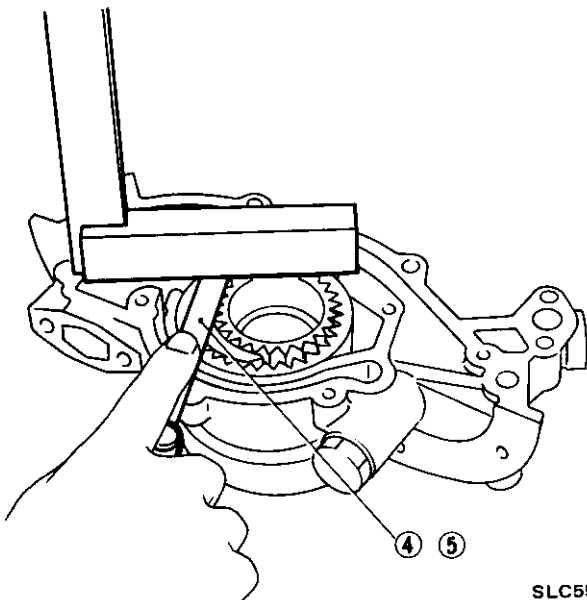

SLC550

If excessive wear is found, replace gear set or entire oil pump assembly.

Standard clearance:

Unit: mm (in)

Body to outer gear clearance ①	0.11 - 0.20 (0.0043 - 0.0079)
Inner gear to crescent clearance ②	0.12 - 0.23 (0.0047 - 0.0091)
Outer gear to crescent clearance ③	0.21 - 0.32 (0.0083 - 0.0126)
Housing to inner gear clearance ④	0.05 - 0.09 (0.0020 - 0.0035)
Housing to outer gear clearance ⑤	0.05 - 0.11 (0.0020 - 0.0043)

Oil Pressure Relief Valve Inspection

Inspect for smooth operation by pushing ball.

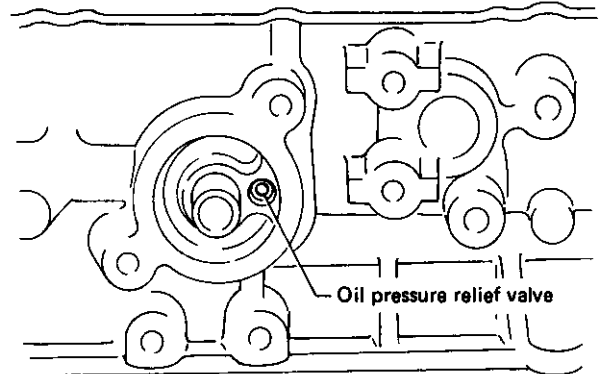

SLC551

Replace as a valve assembly, when replacing.

ENGINE LUBRICATION SYSTEM — For Turbocharged Models

Removal and Installation

OIL DELIVERY SYSTEM

After installation, run engine for a few minutes and check for leaks.

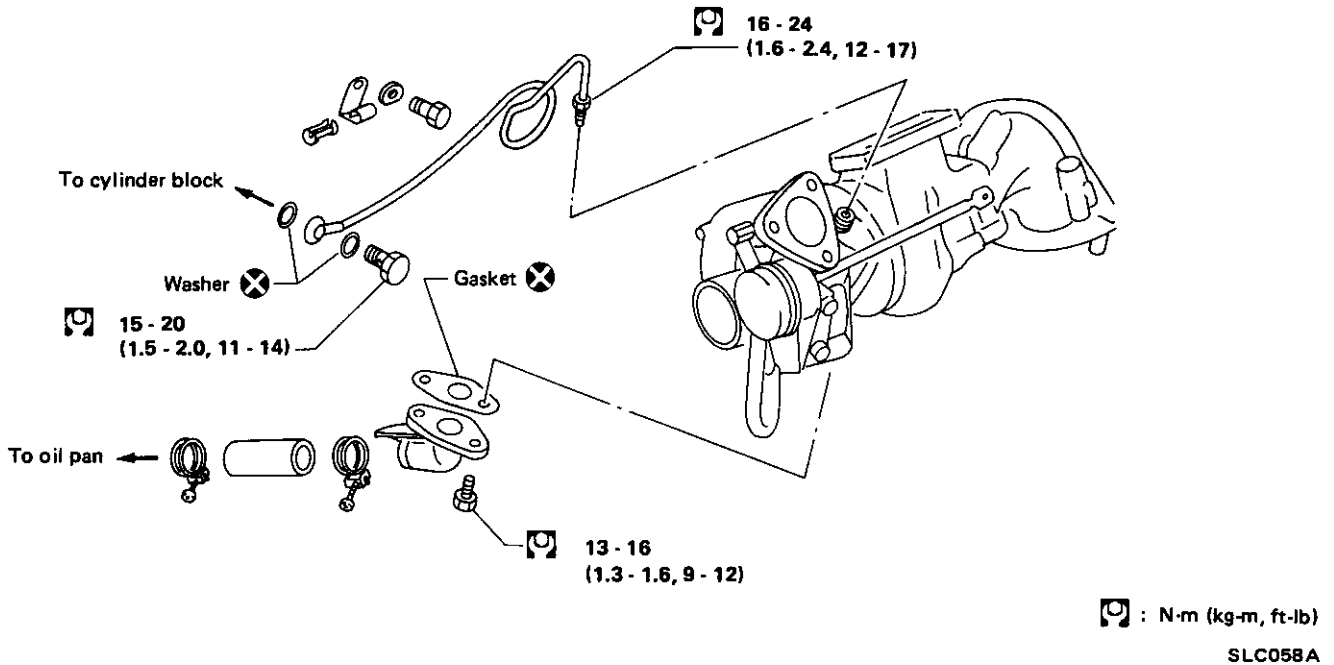

ENGINE OIL COOLER (A/T models)

Be careful not to burn yourself as engine oil is hot.

After installation, run engine for a few minutes and check for oil leaks.

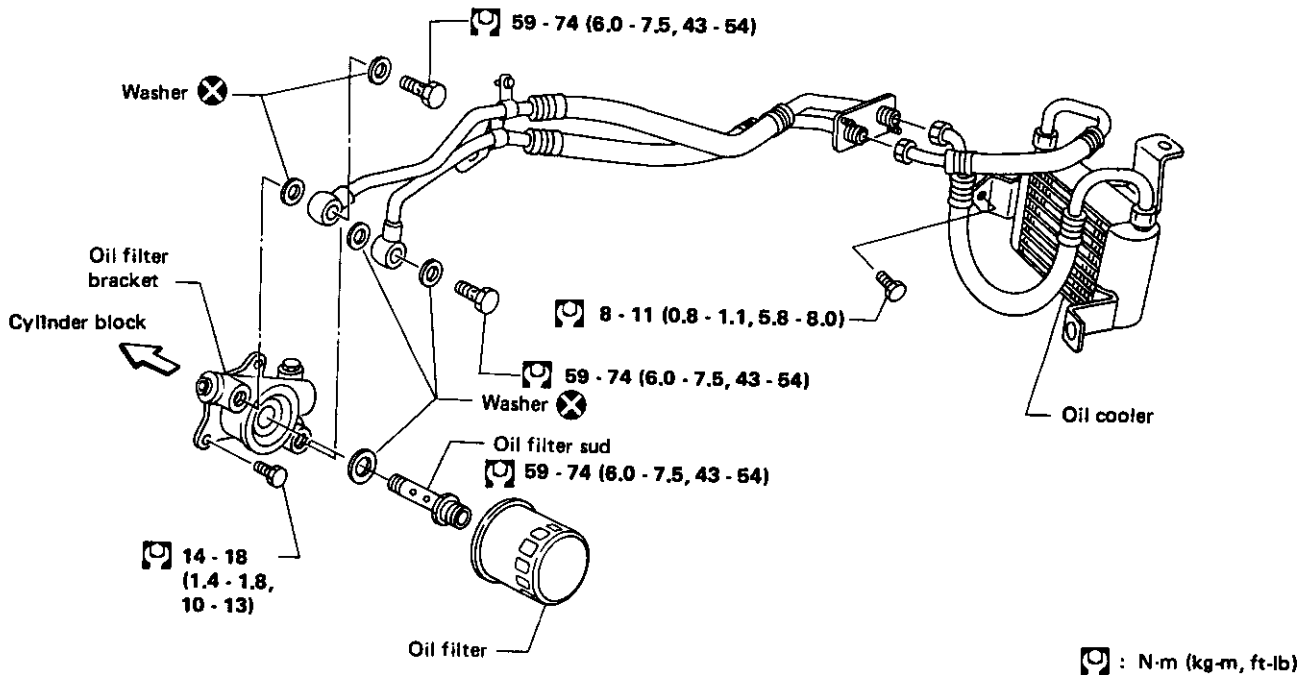

ENGINE COOLING SYSTEM

Cooling Circuit

To avoid danger of being scalded, never attempt to drain coolant when engine is hot.

If it is necessary to remove radiator cap when radiator is hot, turn cap slowly counterclockwise to the first stop. After all pressure in the cooling system is released, turn cap past the stop and remove it.

Always replace with new gasket and O-ring.

Refer to MA section for changing engine coolant.

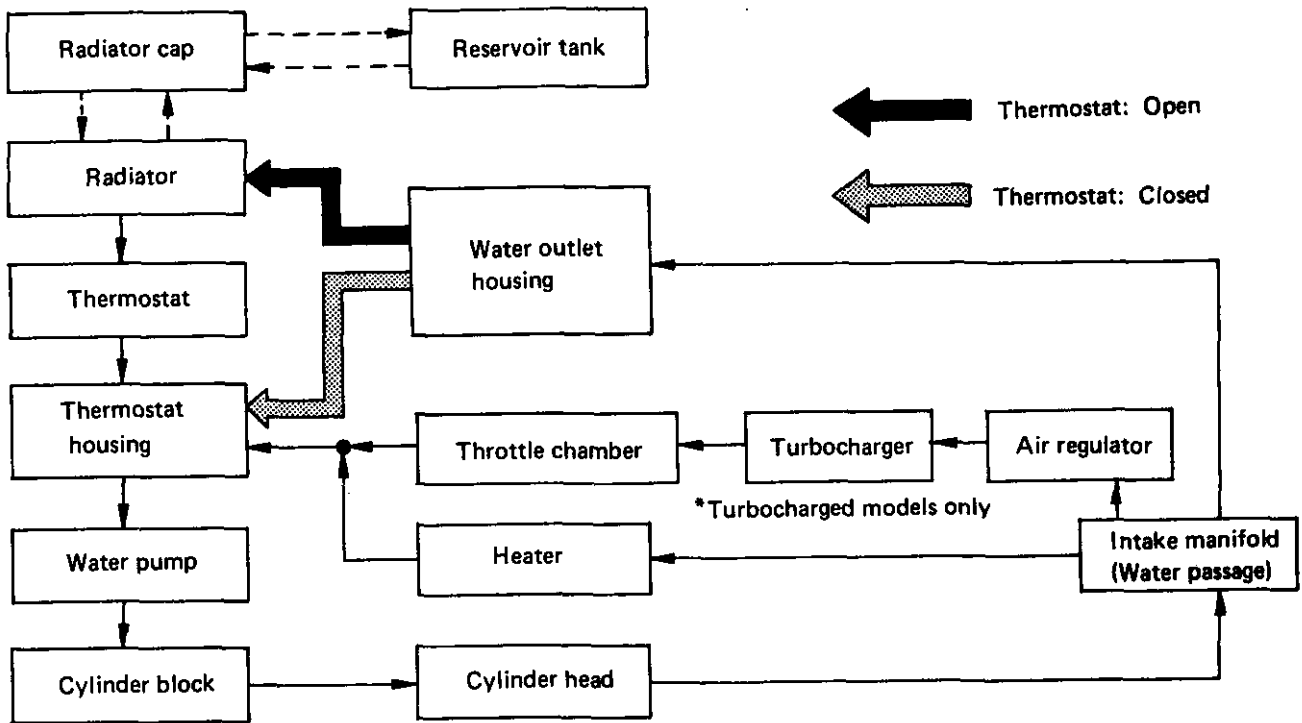

SLC728

ENGINE COOLING SYSTEM

Checking Cooling System

WARNING:

Never remove the radiator cap when the engine is hot; serious burns could be caused by high pressure fluid escaping from the radiator.

Wrap a thick cloth around cap and carefully remove the cap by turning it a quarter turn to allow built-up pressure to escape and then turn the cap all the way off.

CHECKING COOLING SYSTEM HOSES

Check hoses for proper attachment, leaks, cracks, damage, loose connections, chafing and deterioration.

CHECKING COOLING SYSTEM FOR LEAKS

Apply pressure to the cooling system by means of a tester to check for leakage.

Testing pressure:

157 kPa (1.6 kg/cm², 23 psi)

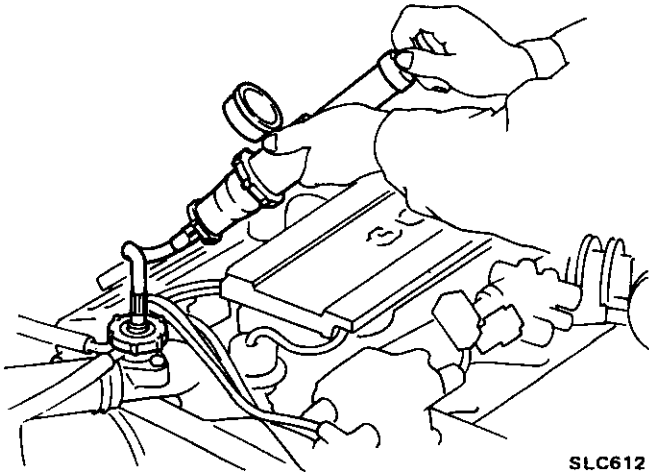

SLC612

CHECKING RADIATOR CAP

Apply pressure to radiator cap by means of a cap tester to see if it is satisfactory.

Radiator cap relief pressure:

78 - 98 kPa (0.8 - 1.0 kg/cm², 11 - 14 psi)

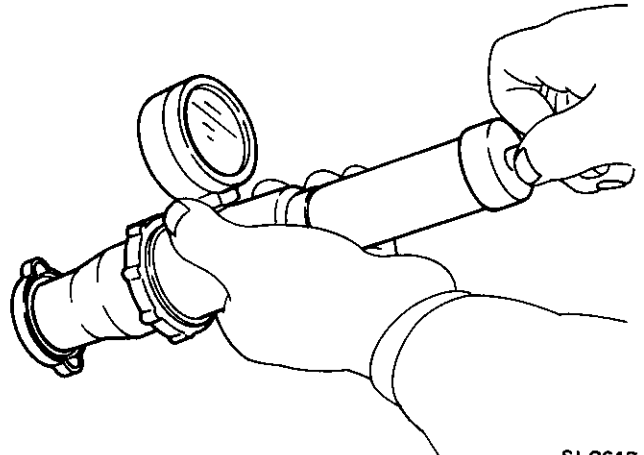

SLC613

ENGINE COOLING SYSTEM

Water Pump Removal and Installation (On-vehicle service)

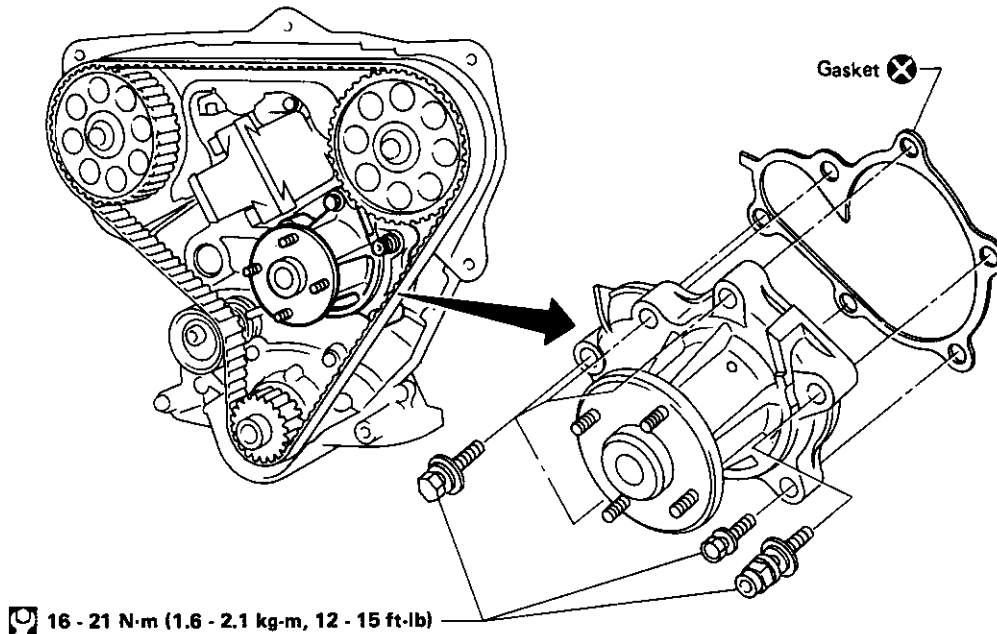

Water pump can not be disassembled and should be replaced as a unit.

To avoid deforming timing cover, make sure there is adequate clearance between cover and hose clamp. After installing water pump, connect hose and clamp securely, then check for leaks using cap tester.

SLC938

Drain coolant from drain plugs on both sides of cylinder block, and radiator.

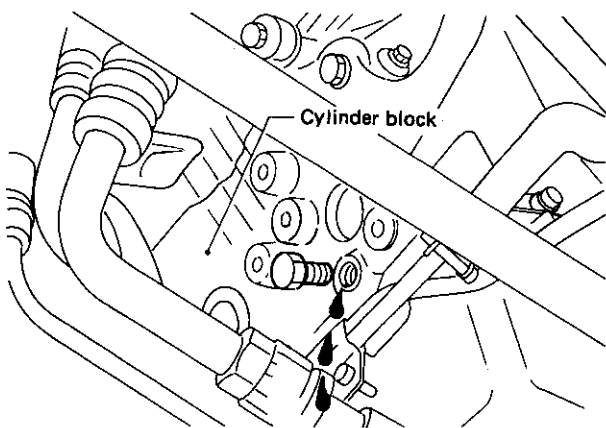

SLC815

CAUTION:

When removing water pump assembly, be careful not to get coolant on timing belt.

Water Pump Inspection

Check for excessive end play and rough operation.

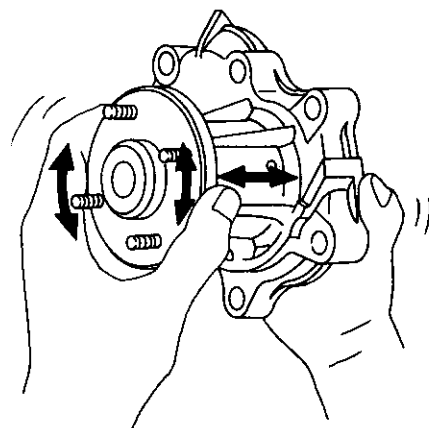

SLC738

ENGINE COOLING SYSTEM

Thermostat Description (Bottom by-pass coolant flow)

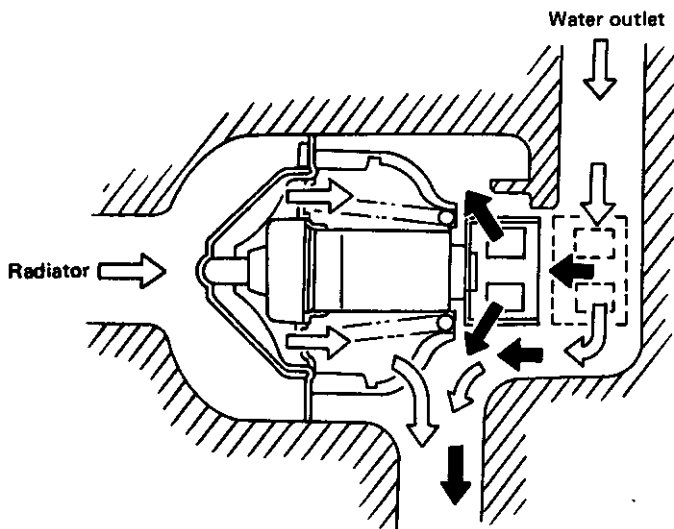

SLC565

Thermostat	Coolant flow out through water outlet
Open	A little
Close	Much

Thermostat Removal and Installation

CAUTION:

Drain coolant from drain cocks on cylinder block side and radiator.

Remove radiator shroud, cooling fan and water suction pipe securing bolt, then remove thermostat.

After installation, run engine for a few minutes, and check for leaks.

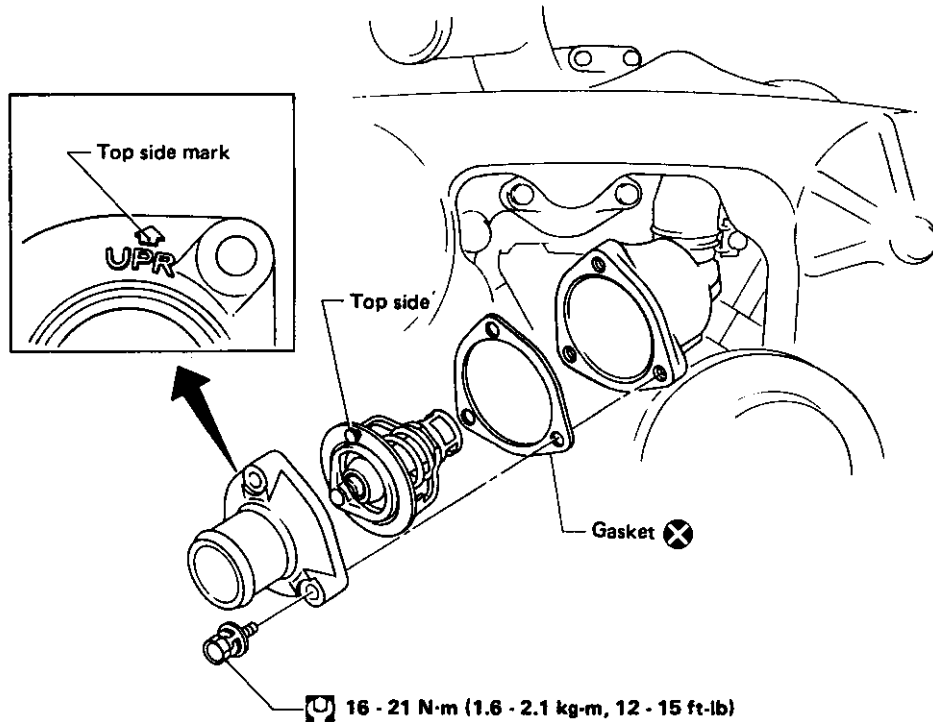

SLC939

ENGINE COOLING SYSTEM

Thermostat Inspection

1. Check for valve seating condition at ordinary temperatures. It should seat tightly.
2. Check valve opening temperature and maximum valve lift.

	Standard
Valve opening temperature °C (°F)	76.5 (170)
Maximum valve lift mm/°C (in/°F)	10/90 (0.39/194)

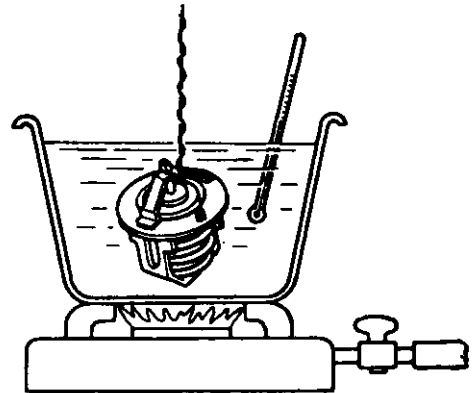

SLC343

3. Then check if valve closes at 5°C (9°F) below valve opening temperature.

Radiator Removal and Installation

Before removing radiator, remove front bumper assembly.

When filling radiator with coolant, refer to MA section.

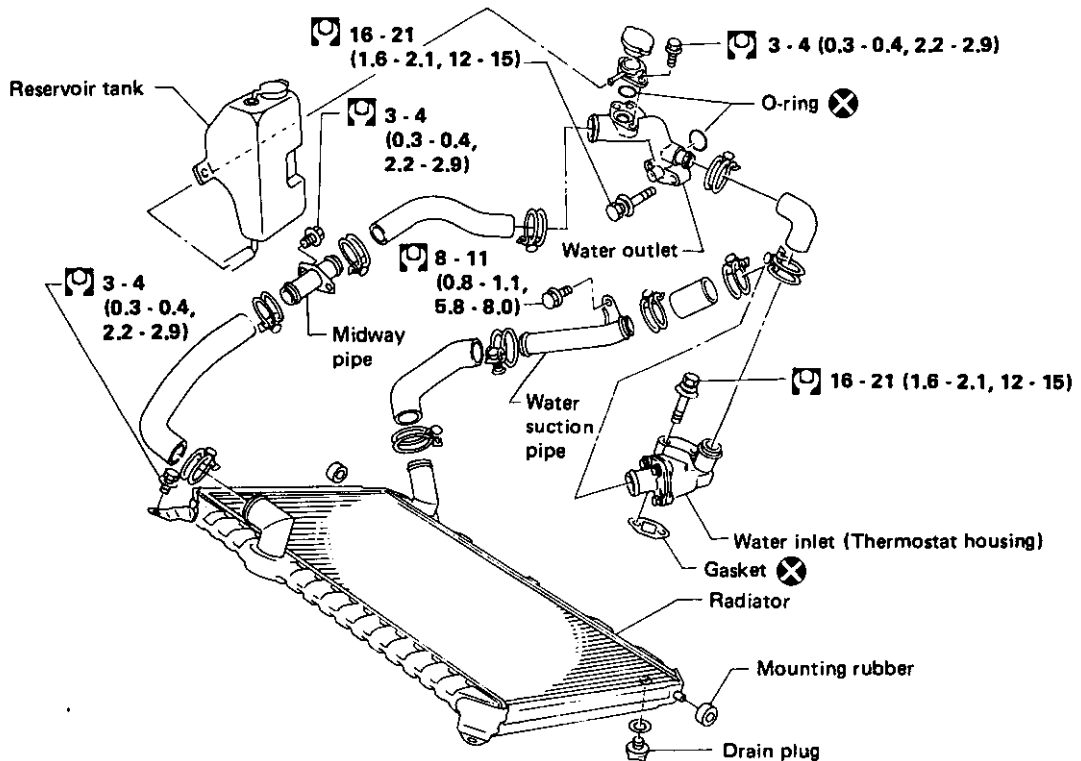

Clamp  3 - 5 (0.3 - 0.5, 2.2 - 3.6)

 : N·m (kg·m, ft·lb)

SLC985

ENGINE COOLING SYSTEM

Cooling Fan Disassembly and Assembly

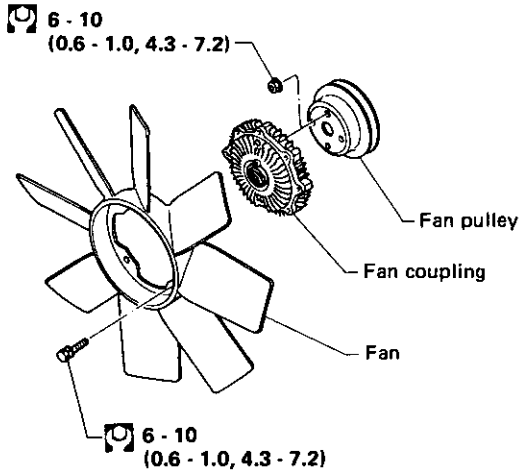

: N-m (kg-m, ft-lb)

SLC558

Cooling Fan Inspection

Check fan coupling for oil leakage or bent bimetal.

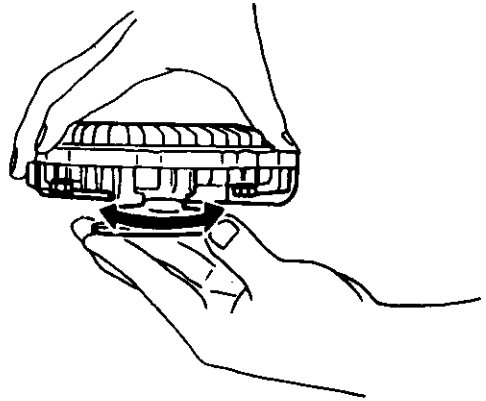

SLC072

ENGINE COOLING SYSTEM—For Turbocharged Models

Electric Cooling Fan Removal and Installation

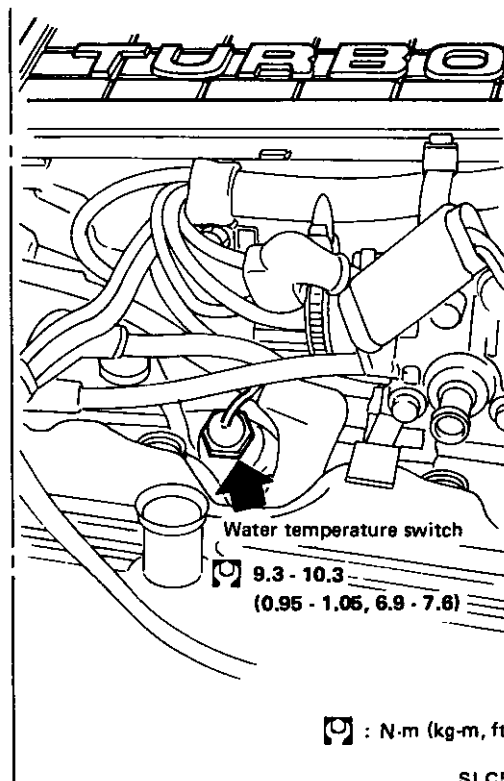
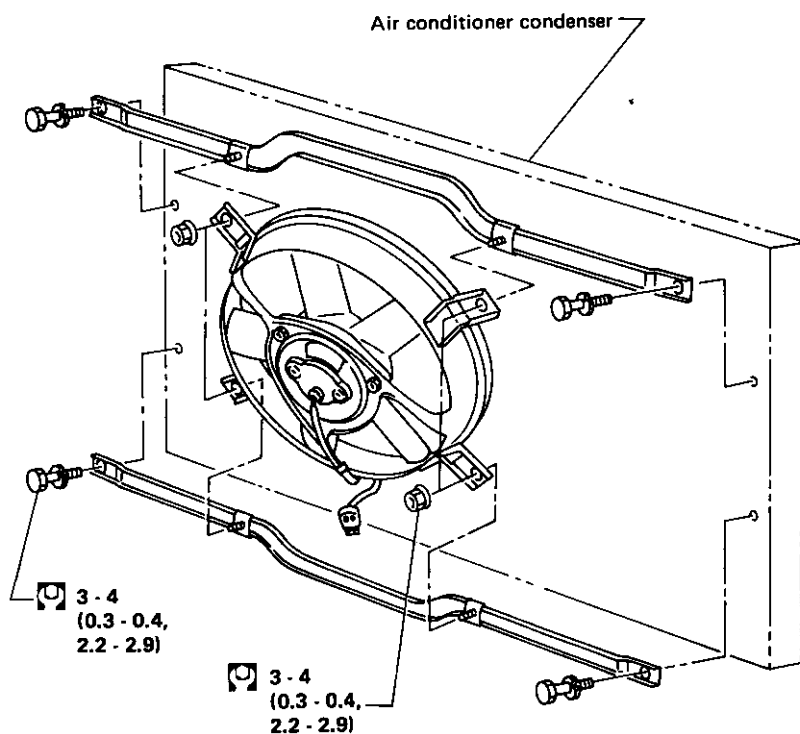

Water Temperature Switch Inspection

Check water temperature switch for proper operation.

Operating temperature:

OFF → ON 100°C (212°F)

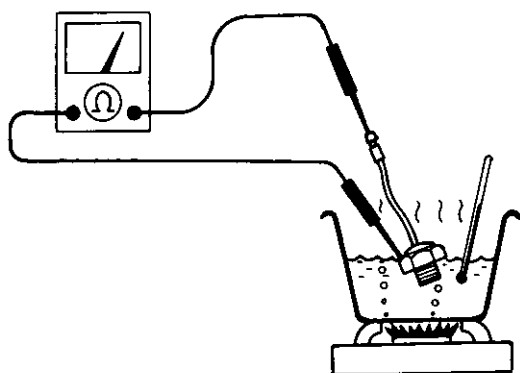

ENGINE COOLING SYSTEM—For Turbocharged Models

Coolant Delivery System Removal and Installation

After installation, run engine for a few minutes and check for leaks.

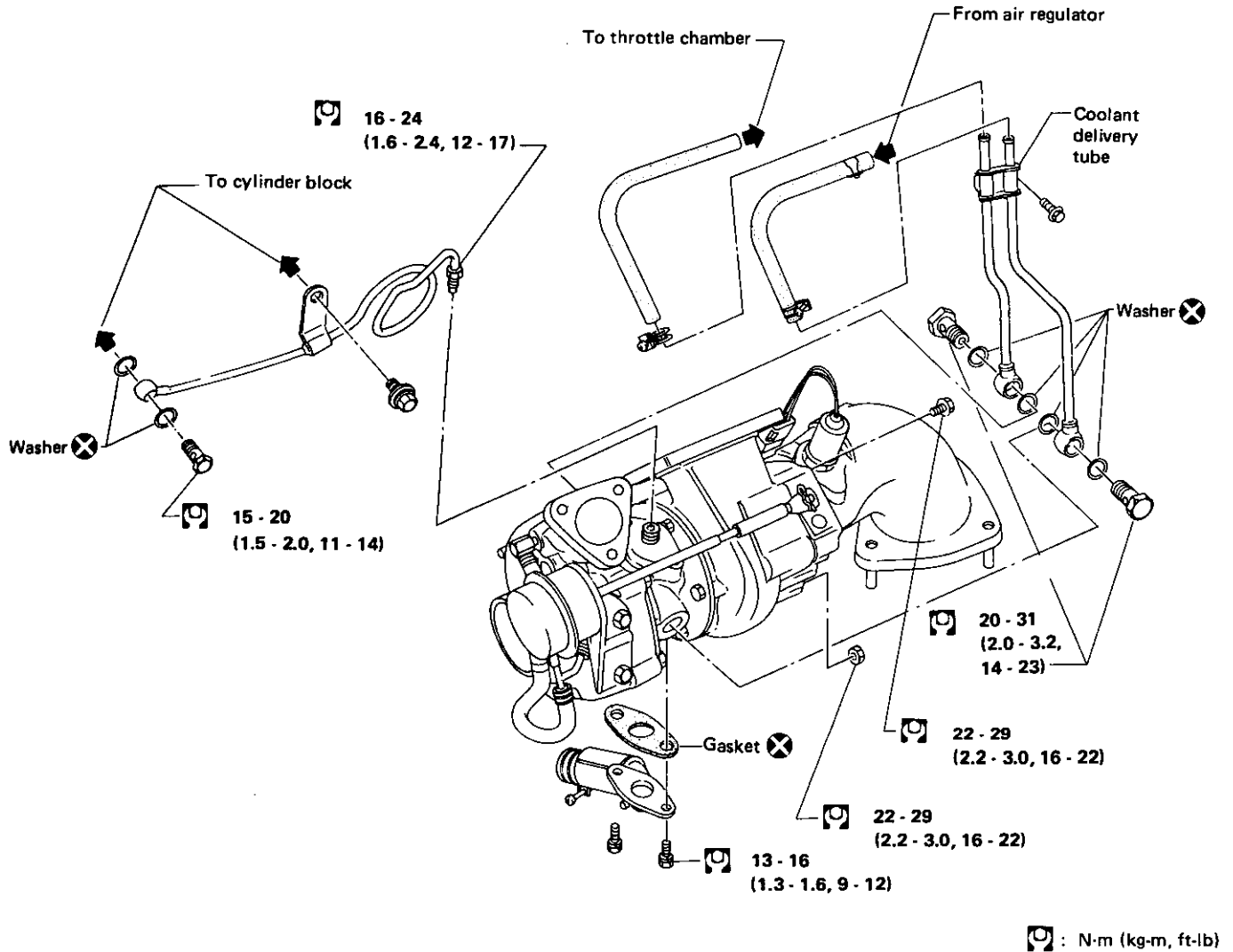

SLC069A

SERVICE DATA AND SPECIFICATIONS (S.D.S.)

Engine Lubrication System

Oil pressure check

Engine rpm	Approximate discharge pressure kPa (kg/cm ² , psi)
Idle speed	More than 59 (0.6, 9)
3,200	Non-turbo 363 - 451 (3.7 - 4.6, 53 - 65) Turbo 373 - 432 (3.8 - 4.4, 54 - 63)

Oil pump

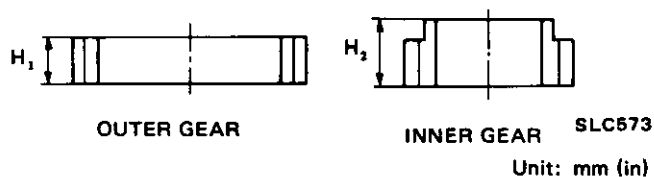

Height	H ₁	H ₂
Except turbo model	12.5 (0.492)	18.5 (0.728)
Turbo model	15.5 (0.610)	21.5 (0.846)

Unit: mm (in)

Body to outer gear clearance ①	0.11 - 0.20 (0.0043 - 0.0079)
Inner gear to crescent clearance ②	0.12 - 0.23 (0.0047 - 0.0091)
Outer gear to crescent clearance ③	0.21 - 0.32 (0.0083 - 0.0126)
Housing to inner gear clearance ④	0.05 - 0.09 (0.0020 - 0.0035)
Housing to outer gear clearance ⑤	0.05 - 0.11 (0.0020 - 0.0043)

Tightening torque

Unit	N·m	kg·m	ft·lb
Oil pump securing bolt			
M6	6 - 7	0.6 - 0.7	4.3 - 5.1
M8	12 - 16	1.2 - 1.6	9 - 12
Oil pump cover screw	4 - 5	0.4 - 0.5	2.9 - 3.6
Regulator valve cap bolt	39 - 49	4 - 5	29 - 36
Oil strainer bolt			
M6	6.3 - 8.3	0.64 - 0.85	4.6 - 6.1
M8	16 - 21	1.6 - 2.1	12 - 15
Oil pressure switch	13 - 17	1.3 - 1.7	9 - 12
Turbocharger			
Oil inlet tube to cylinder block	15 - 20	1.5 - 2.0	11 - 14
Oil inlet tube to turbocharger	16 - 24	1.6 - 2.4	12 - 17
Oil outlet pipe to turbocharger	13 - 18	1.3 - 1.6	9 - 12
Water inlet tube to turbocharger	20 - 31	2.0 - 3.2	14 - 23
Water outlet tube to turbocharger	20 - 31	2.0 - 3.2	14 - 23
Exhaust outlet to turbocharger	22 - 29	2.2 - 3.0	16 - 22
Turbocharger unit	22 - 29	2.2 - 3.0	16 - 22
Engine oil cooler			
Oil filter bracket to cylinder block	14 - 18	1.4 - 1.8	10 - 13
Oil filter stud	59 - 74	6.0 - 7.5	43 - 54
Oil cooler tube to oil filter bracket	59 - 74	6.0 - 7.5	43 - 54
Oil cooler	8 - 11	0.8 - 1.1	5.8 - 8.0

SERVICE DATA AND SPECIFICATIONS (S.D.S.)

Engine Cooling System

Radiator

Unit: kPa (kg/cm², psi)

Cap relief pressure	78 - 98 (0.8 - 1.0, 11 - 14)
Leakage test pressure	157 (1.6 - 23)

Thermostat

Standard

Valve opening temperature °C (°F)	76.5 (170)
Maximum valve lift mm/°C (in/°F)	10/90 (0.39/194)

Temperature switch (Turbocharged model)

Operating temperature

OFF → ON	°C (°F)	100 (212)
----------	---------	-----------

Tightening torque

Unit	N·m	kg·m	ft·lb
Water pump securing bolt	16 - 21	1.6 - 2.1	12 - 15
Thermostat housing securing bolt	16 - 21	1.6 - 2.1	12 - 15
Water inlet securing bolt	16 - 21	1.6 - 2.1	12 - 15
Water outlet securing bolt	16 - 21	1.6 - 2.1	12 - 15
Coolant filler housing bolt	3 - 4	0.3 - 0.4	2.2 - 2.9
Radiator securing bolt	3 - 4	0.3 - 0.4	2.2 - 2.9
Radiator hose clamp	3 - 5	0.3 - 0.5	2.2 - 3.6
Midway pipe to body securing bolt	3 - 4	0.3 - 0.4	2.2 - 2.9
Water suction pipe securing bolt	8 - 11	0.8 - 1.1	5.8 - 8.0
Cooling fan securing bolt	6 - 10	0.6 - 1.0	4.3 - 7.2
Fan coupling securing bolt	6 - 10	0.6 - 1.0	4.3 - 7.2
Electric cooling fan securing bolt and nut	3 - 4	0.3 - 0.4	2.2 - 2.9
Water temperature switch	9.3 - 10.3	0.95 - 1.05	6.9 - 7.6
Coolant delivery tube	31 - 41	3.2 - 4.2	23 - 30

SPECIAL SERVICE TOOLS

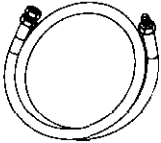
Tool number (Kent-Moore No.)	Tool name
ST25051001 (J25695-1)	Oil pressure gauge 
ST25052000 (J25695-2)	Hose 
EG17650301 (-)	Radiator cap tester adapter 