

SERVICE MANUAL

DATSUN 280Z
MODEL S30 SERIES



SECTION BF

BODY

GENERAL DESCRIPTIONS	BF- 2
UNDERBODY ALIGNMENT	BF- 4
BUMPER AND RADIATOR GRILLE	BF- 7
ENGINE HOOD AND HOOD LOCK	BF-10
COWL TOP GRILLE AND FRONT FENDER	BF-13
TAIL GATE AND REAR PANEL FINISHER	BF-14
DOOR	BF-16
WINDSHIELD GLASS	BF-23
SEAT	BF-25
SEAT BELT	BF-26
INTERIOR TRIM	BF-28
INSTRUMENT PANEL	BF-30
BODY SEALING	BF-31
SPECIAL SERVICE TOOL	BF-32

BF

NISSAN

NISSAN MOTOR CO., LTD.
TOKYO, JAPAN

GENERAL DESCRIPTIONS

There are two different types of body construction, the two-passenger type (S30) and the four-passenger type (GS30 2 + 2 seater). The basic body utilizes a unit construction system for reduced car weight as well as increased rigidity and safety. The fuel tank is

located beneath the floor and the spare tire is stored in the spare tire housing flush with floor level. In addition, the rear of the body is provided with a large tail gate.

The four-passenger type model differs from the two-passenger type in

the following points:

The wheelbase is 300 mm (11.81 in) longer and an extension is placed between the front and rear floors. The door and tail gate panels are of a different design.

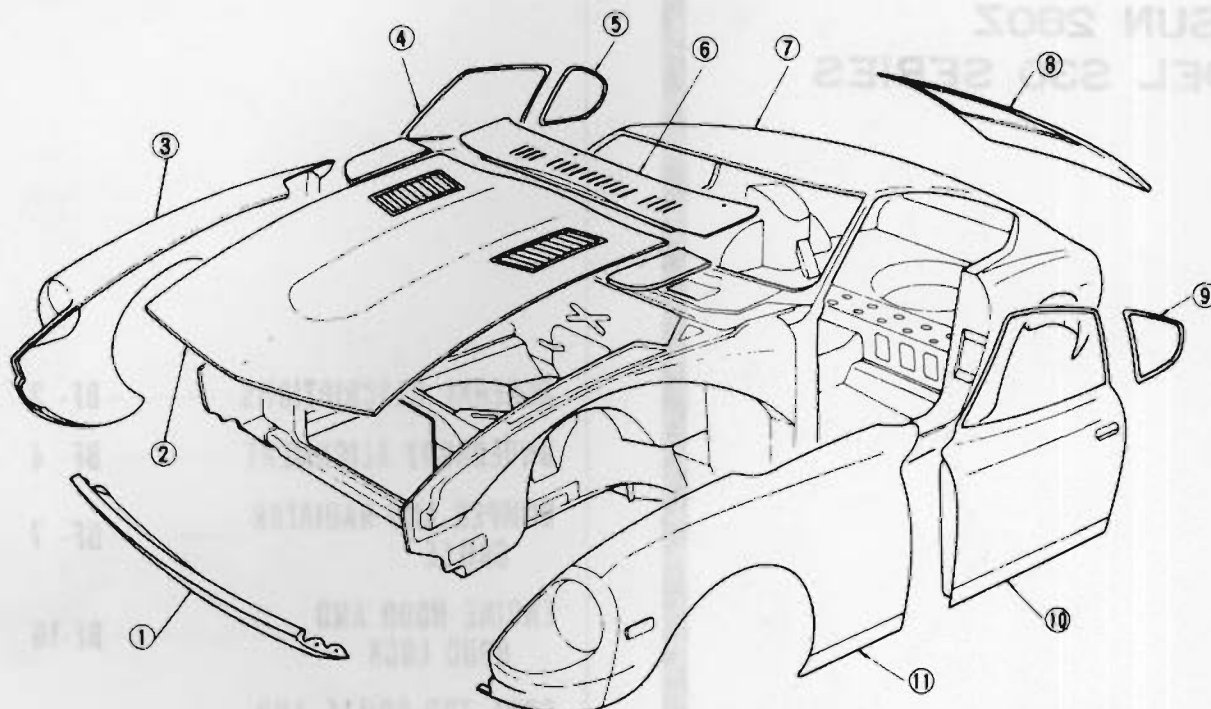

- | | |
|---------------------|----------------------|
| 1 Front apron | 7 Body main unit |
| 2 Hood | 8 Tail gate |
| 3 Front fender (RH) | 9 Side window (LH) |
| 4 Door (RH) | 10 Door (LH) |
| 5 Side window (RH) | 11 Front fender (LH) |
| 6 Cowl top grille | |

BF974A

Fig. BF-1 Body construction

UNDERBODY ALIGNMENT

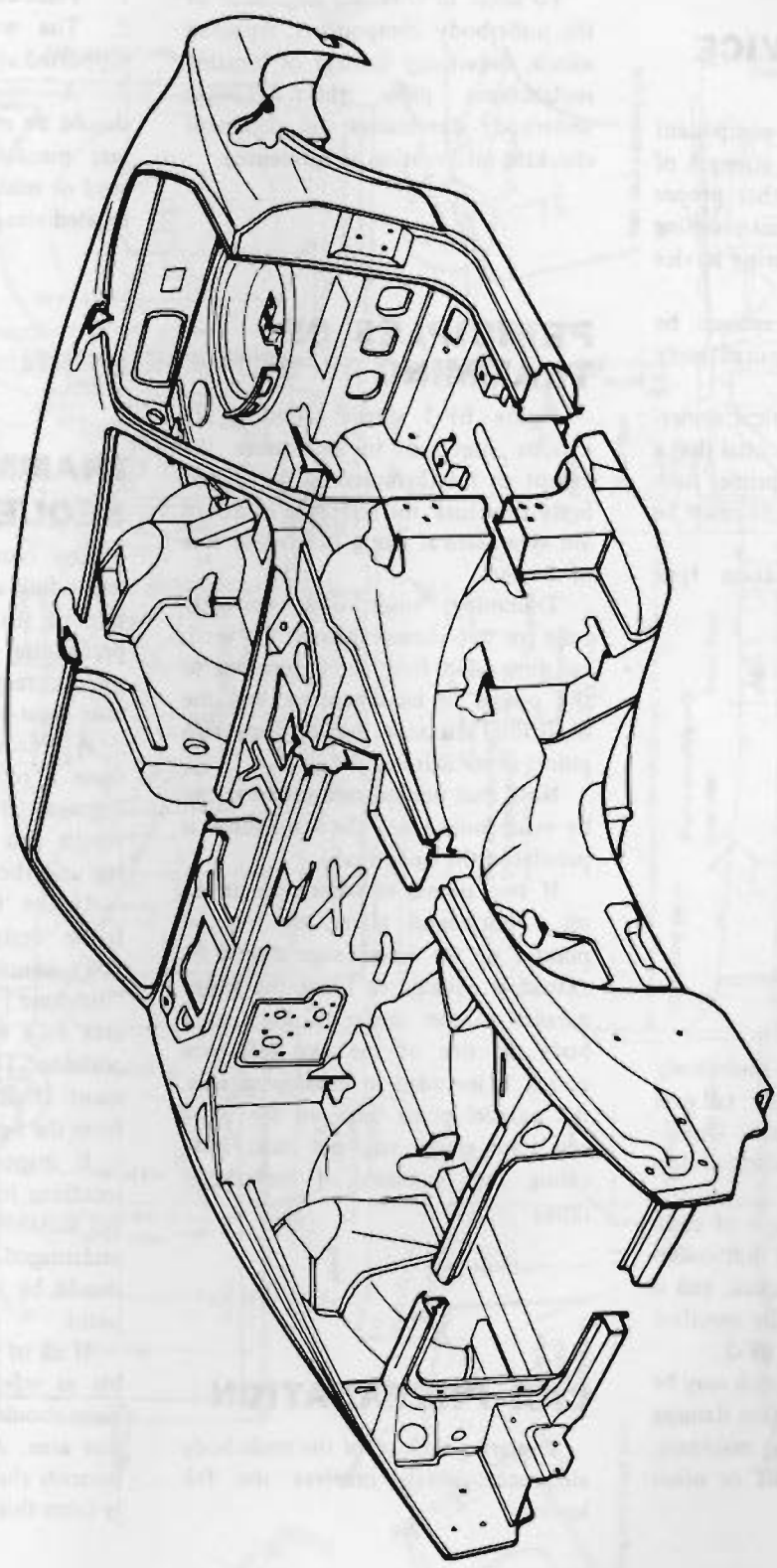

UNDERBODY GENERAL SERVICE INFORMATION

ALIGNMENT CHECKING PROCEDURE

BF3808

Fig. BF-2 Structure of body main unit

UNDERBODY ALIGNMENT

UNDERBODY GENERAL SERVICE INFORMATION

Since each underbody component directly affects the overall strength of the body, it is essential that proper welding, sealing and rust-proofing techniques be observed during service operations.

Whenever the body is repaired, be sure to rust-proof the repaired body parts.

When rust-proofing critical underbody components, it is essential that a good quality air dry type primer such as corrosion resistant zinc chromate be used.

Do not use combination type primer surfacers.

ALIGNMENT CHECKING PROCEDURE

Misalignment in the underbody affects the front fender, door, tail gate and window alignments. Underbody misalignment particularly affects the suspension system.

Accordingly, in the event of collision damage, it is essential that underbody be thoroughly rechecked, and if necessary, aligned within the specified dimensions given in Figure BF-3.

There are many tools which may be employed to correct collision damage such as frame straightening machines, external pulling equipment or other standard body jacks.

To assist in checking alignment of the underbody components, repairing minor underbody damage or locating replacement parts, the following underbody dimensions and alignment checking information are presented.

PRINCIPLES OF TRAMMING

Figure BF-3 shows reference locations required to determine the extent of misalignment in the underbody structure, the reference locations are symmetrical along the center line of the car.

Tramming underbody correctly calls for two measurements: the vertical dimension from the datum line to the points to be measured, and the horizontal distance between any two points of measurement.

Note that precise measurement can be made only when the tram gauge is parallel to the underbody.

If two points of measurement are on a horizontal plane, the vertical pointer of the tram gauge should be extended equally to bring the gauge parallel to the center of the underbody. If one of the two reference points is included in misaligned area, the parallel plane between the body and tram gauge may not exist, indicating the necessity of underbody repair.

CAR PREPARATION

Preparing the car for the underbody alignment check involves the following:

1. Place car on a level surface.
2. The weight of car should be supported at wheel locations.
3. A visual damage inspection should be made to eliminate unnecessary measuring since obviously damaged or misaligned areas may often be located visually.

TRAMMING SEQUENCE

The tramming sequence will vary depending upon the nature and location of the misaligned area. Prior to performing any tramming operation, the accuracy of reference points to be used must be determined.

A measurement that originates from a reference point located in a damaged area will produce untrue results and confuse the evaluation of the underbody construction.

Unlike the conventional type of frame design, the unitized type of body construction seldom develops a "diamond" condition in the floor pan area as a result of front or rear end collision. Therefore, underbody alignment checking can usually originate from the body floor pan area.

If inspection indicates that these locations have been disturbed and are not suitable for measuring, one of the undamaged suspension locations should be used as an initial reference point.

If all of these locations are unsuitable as reference points, repair operations should begin with the body floor pan area. All other underbody components should be aligned progressively from this area.

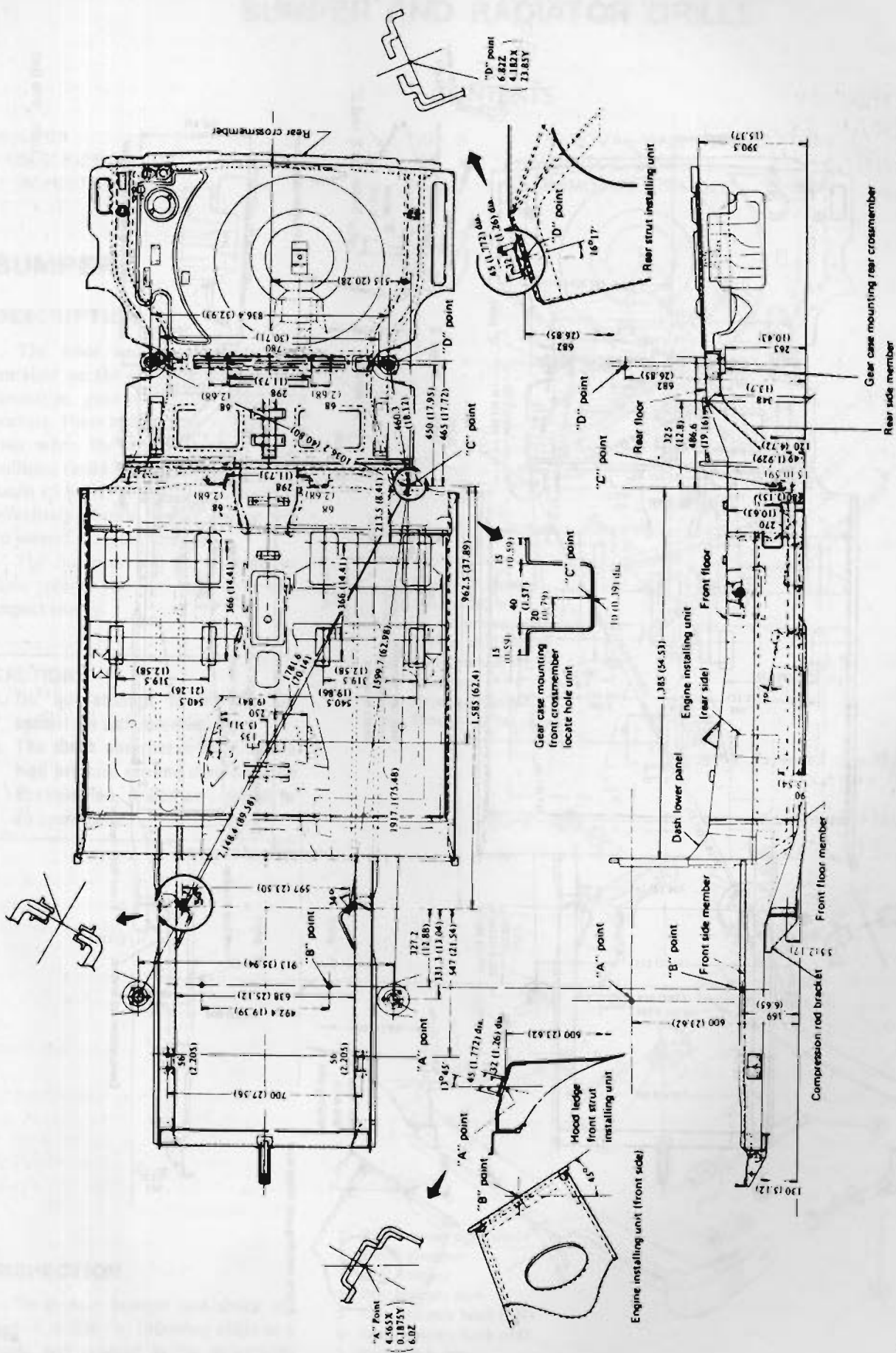

Unit: mm (in)

BF3B18

Fig. BF-3 Underbody alignment for S30 (2 seater)

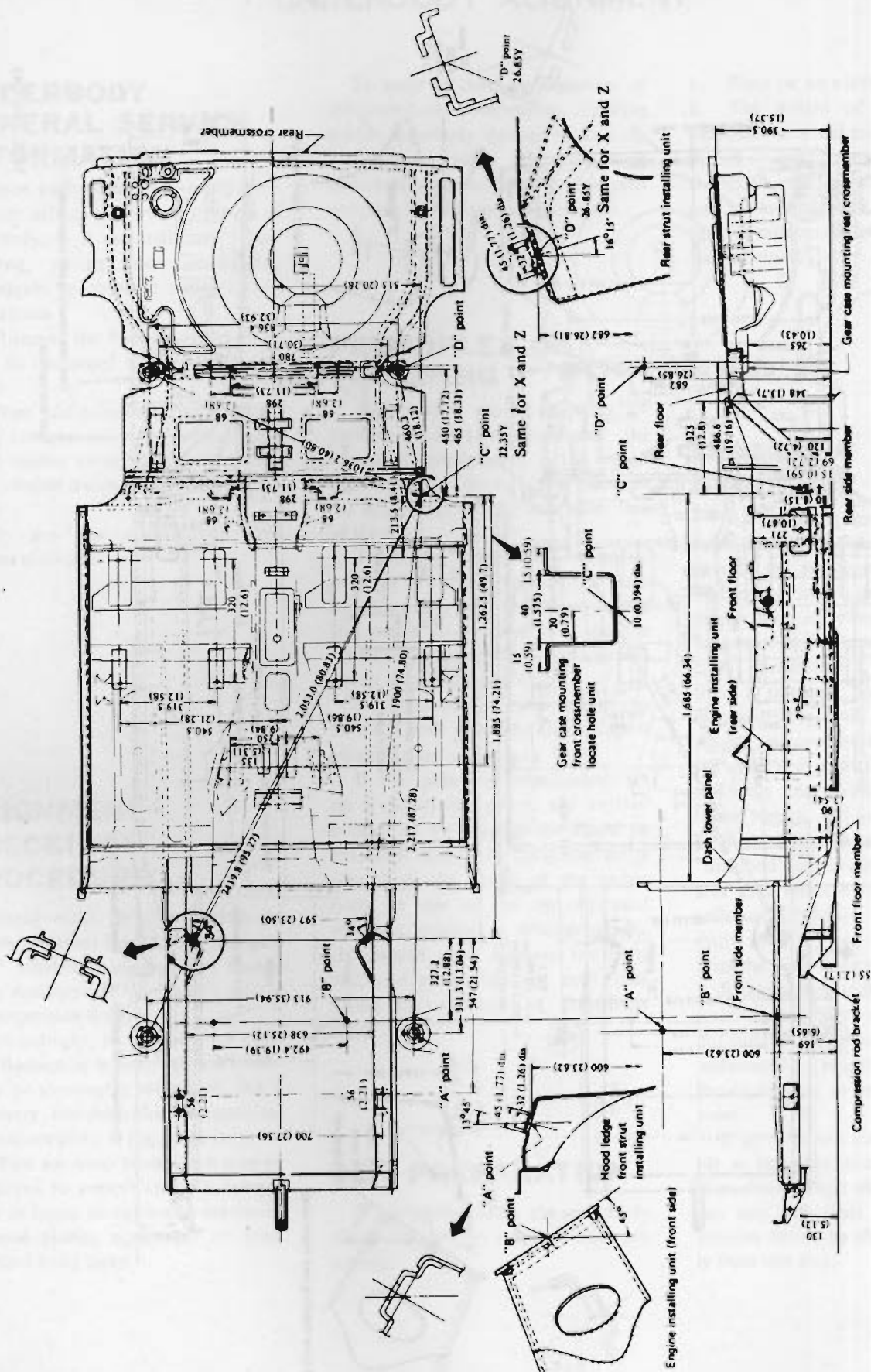

Unit: mm (in)

Fig. BF-4 Underbody alignment for GS30 (2 + 2 seater)

BUMPER AND RADIATOR GRILLE

CONTENTS

BUMPER	BF- 7	REMOVAL AND INSTALLATION	BF- 9
DESCRIPTION	BF- 7	RADIATOR GRILLE	BF-10
INSPECTION	BF- 7	REMOVAL AND INSTALLATION	BF-10

BUMPER

DESCRIPTION

The front and rear bumpers are installed on the car body through the strut-type, gas-and-oil-filled shock absorbers. These bumpers are so designed that when the car is involved in a collision (solid barrier) at a speed of 8 km/h (5 MPH) or less, they retract to effectively absorb impact energy and to prevent car from damage.

The bumpers will be returned to their original positions upon absorbing impact energy.

CAUTION:

- a. Do not attempt to hit the car against the wall intentionally.
- b. The shock absorber is filled with a high pressure gas and should not be disassembled, drilled or exposed to an open flame.

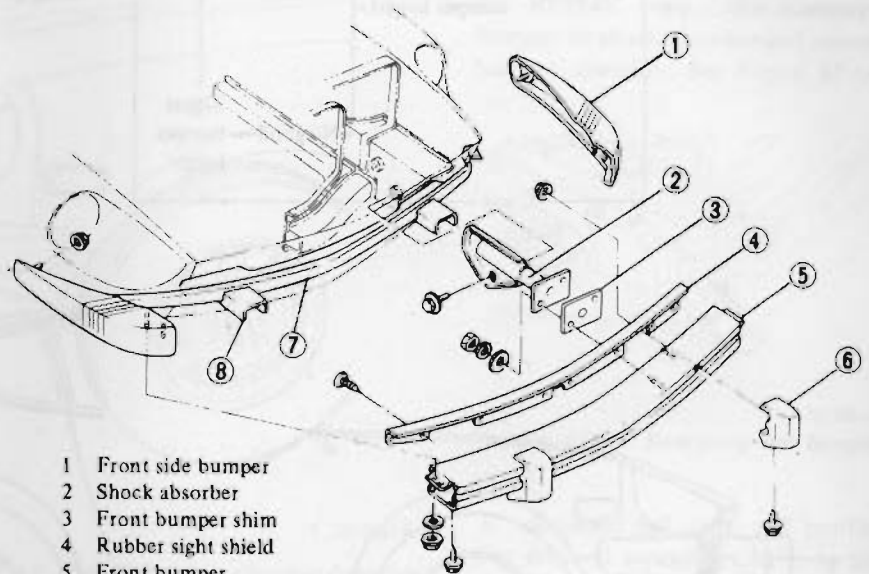

- 1 Front side bumper
- 2 Shock absorber
- 3 Front bumper shim
- 4 Rubber sight shield
- 5 Front bumper
- 6 Overrider
- 7 Metal sight shield
- 8 Shock absorber cover

BF383B

Fig. BF-5 Exploded view of front bumper

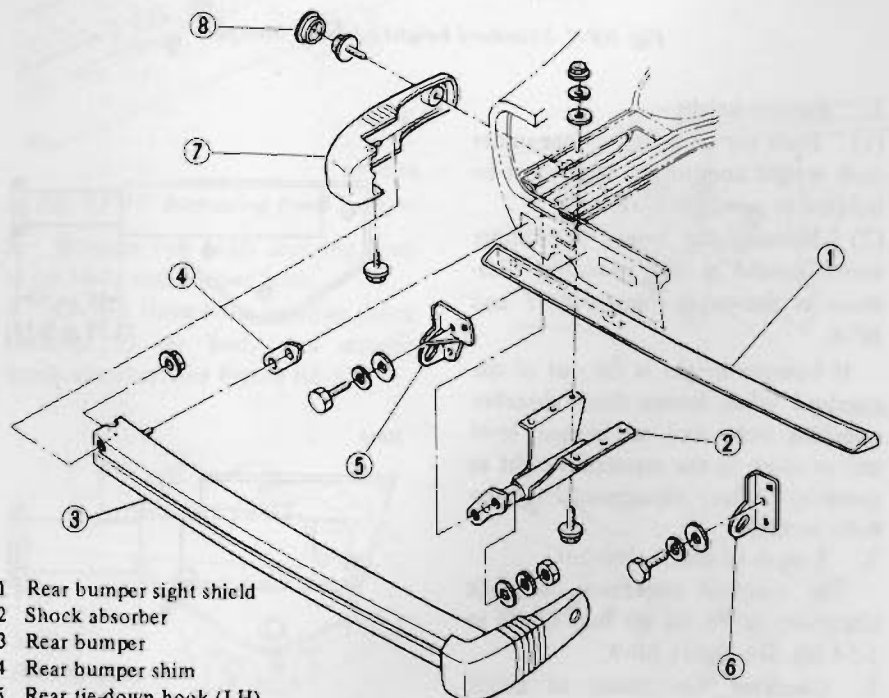

- 1 Rear bumper sight shield
- 2 Shock absorber
- 3 Rear bumper
- 4 Rear bumper shim
- 5 Rear tie-down hook (LH)
- 6 Rear tie-down hook (RH)
- 7 Rear side bumper
- 8 Rubber plug

BF384B

Fig. BF-6 Exploded view of rear bumper

INSPECTION

To inspect bumper and shock absorber, utilize the following chart as a guide and proceed in the order indicated in the chart.

Bumper system inspection chart

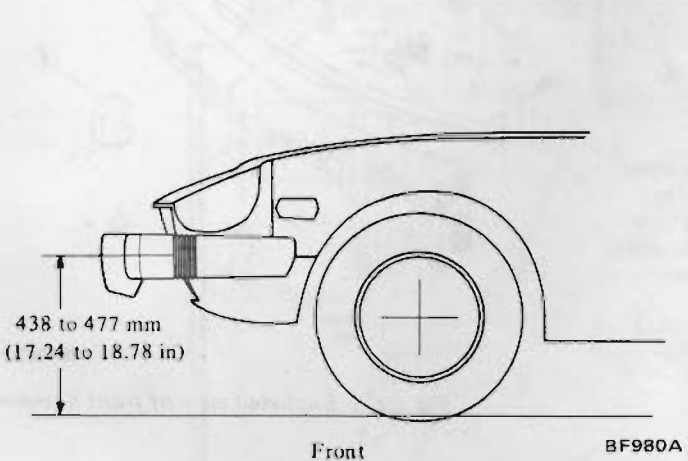
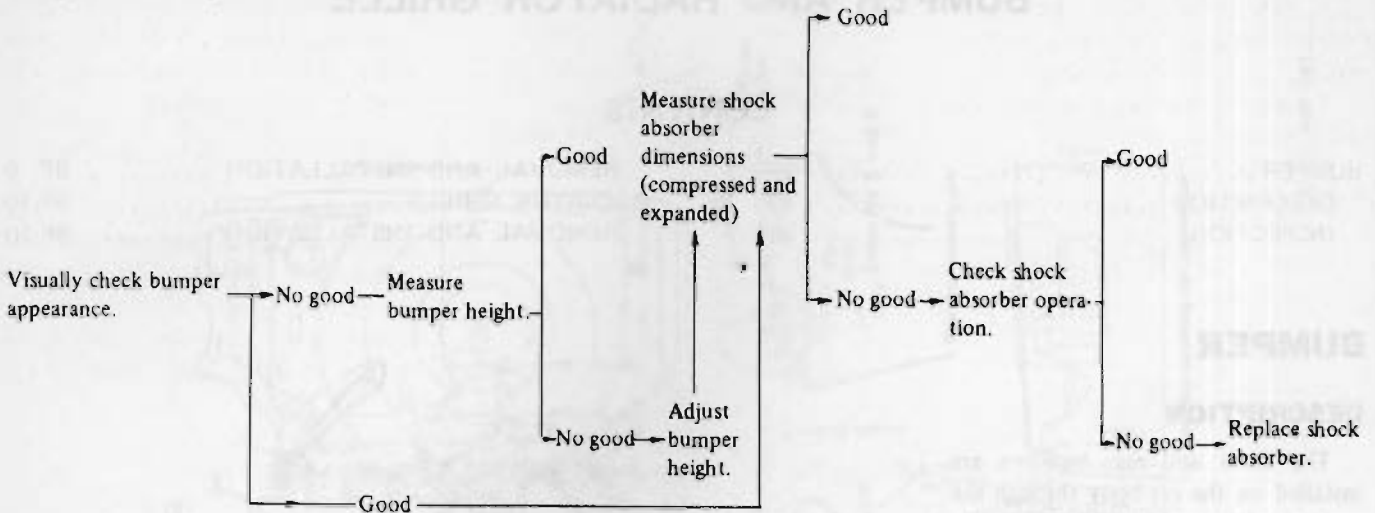

Fig. BF-7 Standard height of front bumper

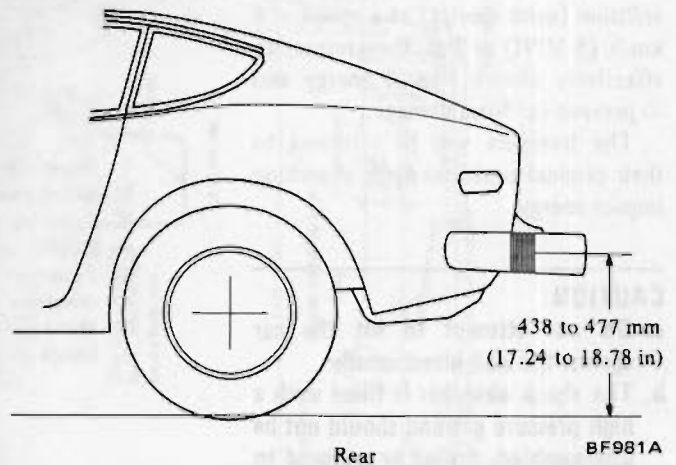

Fig. BF-8 Standard height of rear bumper

1. Bumper height

(1) Place car on a flat surface under curb weight conditions. Tires must be inflated to rated pressure.

(2) Measure the height of bumper above ground at two mounting locations as shown in Figures BF.7 and BF.8.

If bumper height is far out of the standard value, loosen shock absorber attaching bolts and set bumper level and as close to the standard height as possible. After adjustment, tighten bolts securely.

2. Length of shock absorber

The standard dimension of shock absorbers is 86 to 90 mm (3.39 to 3.54 in). See Figure BF-9.

3. Checking functioning of shock absorber

(1) Locate car with the front side towards a solid wall or pillar.

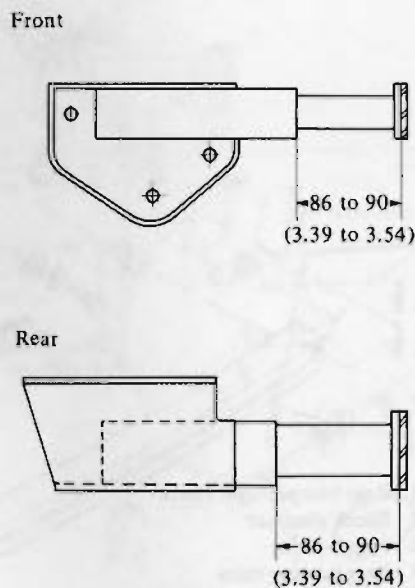

Unit: mm (in)

BF348A

Fig. BF-9 Length of shock absorber

(2) Set parking brake and set transmission in 1st gear (manual transmission), or park position (automatic transmission).

Place wheel chocks securely.

Note:

- a. Make sure that car does not move at all.
- b. Make sure that ignition switch is turned off.

(3) Place a jack between wall and either bumper override aligning it with shock absorber on that side.

Note: Use a jack of more than 400 kg (881 lb) capacity.

(4) Gradually extend jack approximately 40 mm (1.57 in). [The bumper should move approximately 40 mm (1.57 in) back through shock absorber

effect]. See Figure BF-10.

(5) Retract jack and check that bumper returns to its original position without binding and hesitation.

Conduct a test as above on the other shock absorber.

If either shock absorber fails to return to the original position, replace.

(6) Utilize the same test procedure as above when testing rear bumper shock absorbers.

CAUTION:

Be careful not to allow jack slipping out of overrider.

5. Install front bumper assembly in the reverse order of removal.

When installing bumper, set its level and as close to the standard height as possible. See Figure BF-7.

Rear bumper

1. Remove side bumper plug, then remove two bolts securing rear side bumper to car body.

2. Remove two nuts securing bumper to shock absorber and remove bumper assembly. See Figure BF-14.

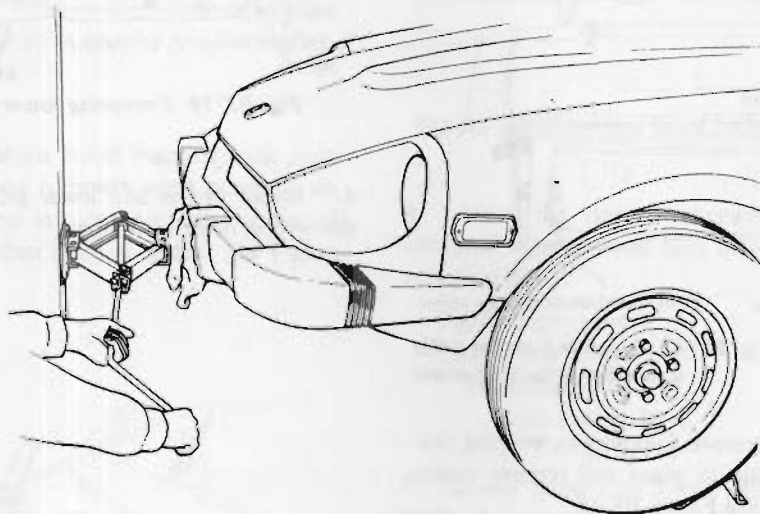

BF982A

Fig. BF-10 Checking shock absorber function

REMOVAL AND INSTALLATION

Front bumper

1. Loosen three screws securing front inner fender front protector to car body, then remove two nuts securing front side bumper to car body.

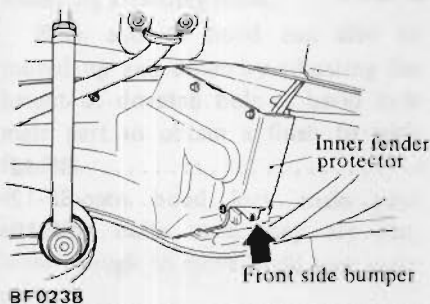

BF023B

Fig. BF-11 Removing front side bumper securing nut

2. Remove two nuts securing bumper to shock absorber and remove bumper assembly. See Figure BF-12.

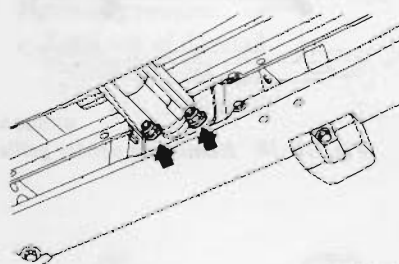

BF983A

Fig. BF-12 Removing front bumper

3. Remove two bolts securing horn to car body and remove horn.

4. Loosen three bolts securing shock absorber to car body and remove shock absorber. See Figure BF-13.

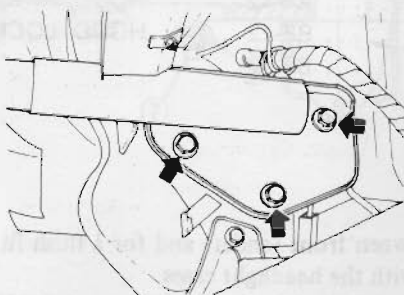

BF498A

Fig. BF-13 Removing shock absorber

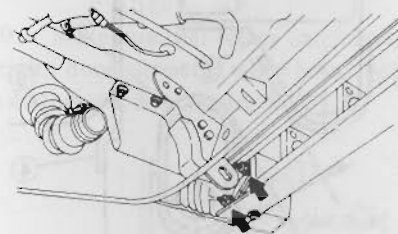

BF984A

Fig. BF-14 Removing rear bumper

3. Remove fuel tank and muffler. For removal procedures, refer to Section FE.

4. Remove bolts and nuts securing shock absorber to car body, and take shock absorber out of the opening in car body. See Figure BF-15.

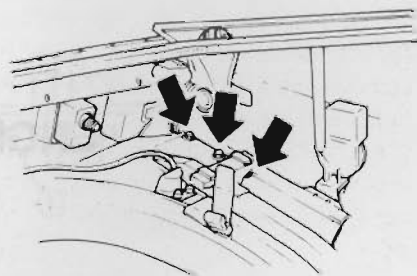

BF985A

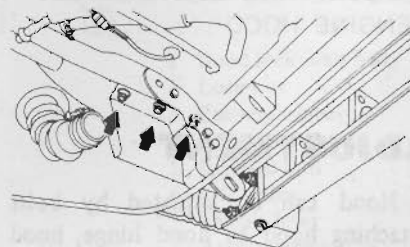

BF986A

Fig. BF-15 Removing shock absorber

5. Install rear bumper assembly in the reverse order of removal.

When installing bumper, set it level and as close to the standard height as possible. See Figure BF-8.

● California models:

Make sure that clearance between muffler and left shock absorber heat shield, and between muffler and spare tire housing heat shield is as indicated in Figure BF-16.

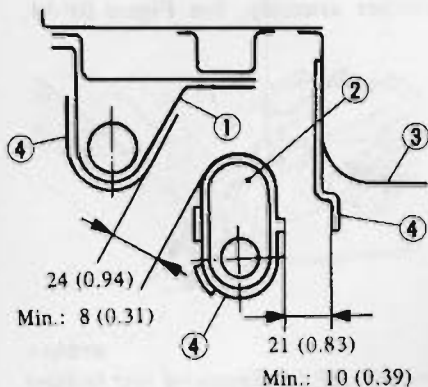

- Unit: mm (in)
- 1 Shock absorber bracket
 - 2 Muffler
 - 3 Spare tire housing
 - 4 Heat shield plate
- BF 385B

Fig. BF-16 Clearances between muffler and L.H. shock absorber heat shield (California models)

RADIATOR GRILLE

REMOVAL AND INSTALLATION

1. Loosen two screws securing front combination lamp cover and move cover inside, then remove screw securing center grille upper bar to body. See Figure BF-17.

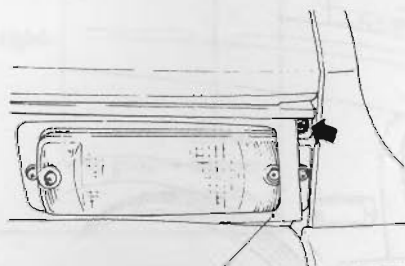

BF 499A Front combination lamp cover

Fig. BF-17 Removing center grille upper bar attaching screw

2. Remove four screws securing center grille in place and remove center grille. See Figure BF-18.

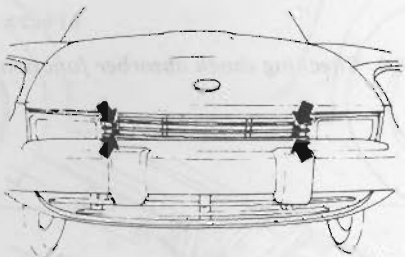
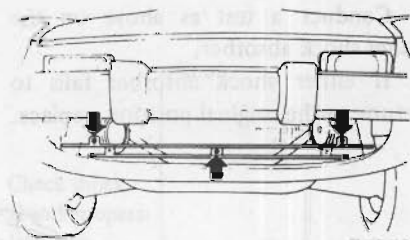

Fig. BF-18 Removing center grille

3. Remove three screws securing lower grille in place and remove lower grille. See Figure BF-19.



BF 501A

Fig. BF-19 Removing lower grille

4. Install center and lower grille in the reverse order of removal.

ENGINE HOOD AND HOOD LOCK

CONTENTS

ADJUSTMENT	BF-10	TORSION BAR	BF-12
LUBRICATION	BF-12	HOOD HINGE	BF-12
REMOVAL AND INSTALLATION	BF-12	HOOD LOCK	BF-12
ENGINE HOOD	BF-12		

ADJUSTMENT

Hood can be adjusted by bolts attaching hood to hood hinge, hood lock mechanism and hood bumpers.

Adjust hood for an even fit be-

tween front fenders and for a flush fit with the headlight cases.

Adjust hood according to the following procedure:

1. Adjust hood fore and aft by loosening bolts attaching hood to hinge and repositioning hood. See Figure BF-20.

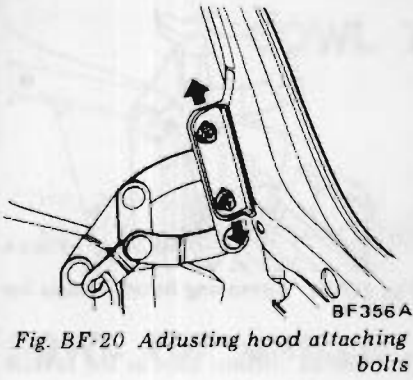

Fig. BF-20 Adjusting hood attaching bolts

2. Loosen hood bumper lock nuts and lower bumpers until bumpers do not come into contact with the rear of hood when hood is closed. See Figure BF-21.

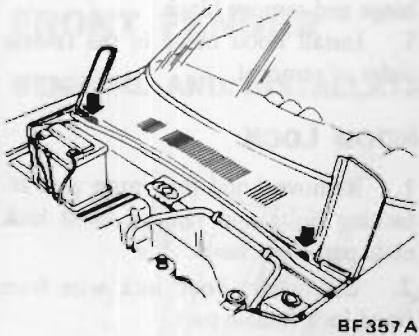

Fig. BF-21 Adjusting hood bumper height

3. Adjust hood lock mechanism after hood has been properly aligned. Hood lock male part can be moved fore and aft and from side to side to align it with hood lock female part by loosening attaching bolts.

Rear end of hood can also be moved up and down by adjusting the height of dovetail bolt of hood lock male part to obtain a flush fit with fenders.

4. Loosen hood lock male part attaching bolts until they are just loose enough to move hood lock male part.

5. Move hood lock male part until it is aligned with hood lock female part. See Figure BF-22.

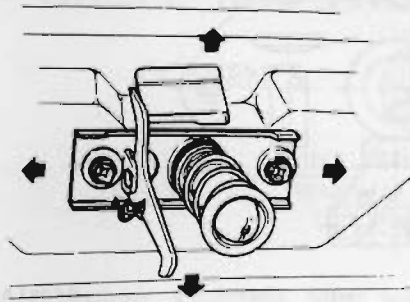

Fig. BF-22 Adjusting hood lock male part

6. After the desired alignment is obtained, tighten hood lock male part attaching bolts.

Tightening torque:

Male and female part attaching bolts
0.38 to 0.51 kg-m
(2.7 to 3.7 ft-lb)

7. Lower hood 1 to 3 mm (0.04 to 0.12 in) from top of front fender by adjusting dovetail bolt.

After the desired alignment is obtained, tighten lock nut of dovetail.

Tightening torque:

Lock nut of dovetail
1.5 to 2.6 kg-m
(11 to 19 ft-lb)

8. Raise two hood bumpers until hood is flush with fenders.

9. Open and close hood several times to check the operation.

Check hood lock male part for complete engagement with hood lock female part.

Note: Full engagement must be obtained for proper hood lock male part adjustment. If complete engagement is not obtained, readjust hood lock male part for full engagement of dovetail bolt and hood lock female part.

10. Make sure that safety catch lever retains hood properly when hood lock is disengaged. See Figure BF-23.

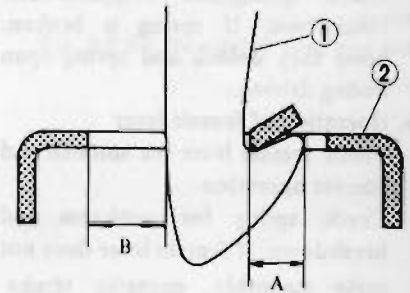

1 Safety catch lever
2 Hood lock female part
A: 5.0 mm (0.197 in)
B: 8.0 mm (0.315 in)

BF360A

Fig. BF-23 Safety catch lever

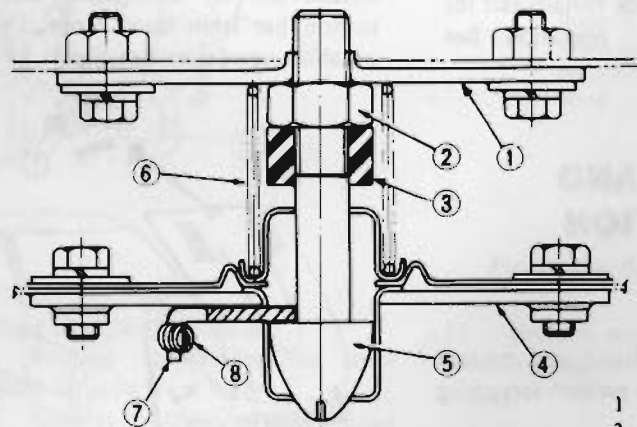

1 Hood lock male body
2 Lock nut
3 Cushion rubber
4 Hood lock female
5 Dovetail bolt
6 Lift spring
7 Female lever
8 Return spring

BF358A

Fig. BF-24 Sectional view of hood lock

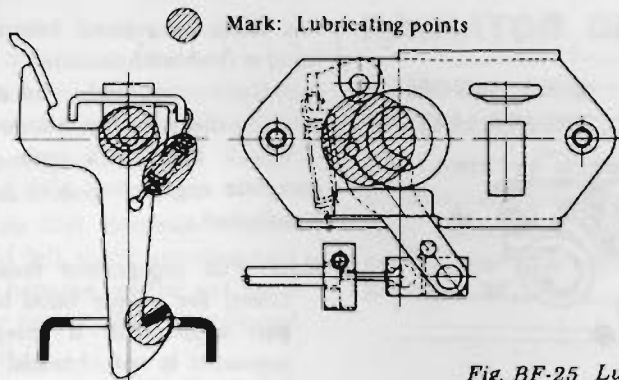

BF361A
Fig. BF-25 Lubricating points

Note: When inspecting the hood lock, observe the following:

- a. Operation of safety catch lever
Check caulking portion of safety catch lever shaft for wear.
Check spring for weakness and breakdown. If spring is broken, hood may unlock and spring open during driving.
- b. Operation of female lever
Check female lever for smooth and correct operation.
Check spring for weakness and breakdown. If female lever does not move smoothly, engaging stroke will be reduced, and it may be disengaged from the hood lock.

LUBRICATION

When checking or adjusting the hood lock, thoroughly lubricate the pivot, catcher and return spring of the safety catch lever. Also lubricate the lever of the hood lock female part for smooth and correct operation. See Figure BF-25.

REMOVAL AND INSTALLATION

ENGINE HOOD

1. Open engine hood and protect body with covers to prevent scratching the paint.
2. Mark hood hinge locations on hood for proper reinstallation.
3. Support engine hood with hand and remove bolts securing hood hinge to hood, taking care not to let the hood slip when bolts are removed. See Figure BF-26.

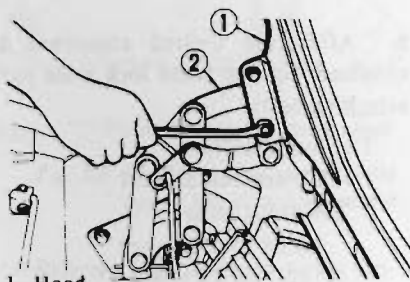

1 Hood
2 Hood hinge
BF362A
Fig. BF-26 Removing hood

4. Remove hood from car.
5. Install hood in the reverse order of removal.

TORSION BAR

1. Open engine hood.
2. Support hood and remove each torsion bar by disengaging end of torsion bar from hood hinge. Use a suitable screwdriver. See Figure BF-27.

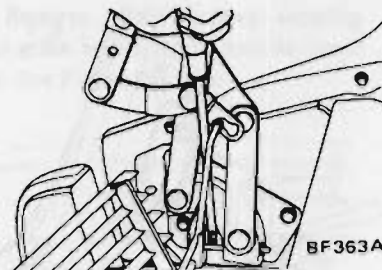

BF363A
Fig. BF-27 Removing hood torsion bar

3. Install torsion bars in the reverse order of removal.

HOOD HINGE

1. Open engine hood and protect body with covers to prevent scratching the paint.
2. Remove hood.
3. Remove torsion bars.
4. Remove screws securing hood hinge and remove hinge.
5. Install hood hinge in the reverse order of removal.

HOOD LOCK

1. Remove hood lock male part attaching bolts and remove hood lock male part from hood.
2. Disconnect hood lock wire from hood lock female part.
3. Remove hood lock female part attaching bolts and remove hood lock female part from hood lock bracket.
4. Remove clamp attaching screw and remove clamp. Remove hood lock wire bracket attaching screws. Then, remove hood lock wire.
5. Install hood lock mechanism in the reverse order of removal.

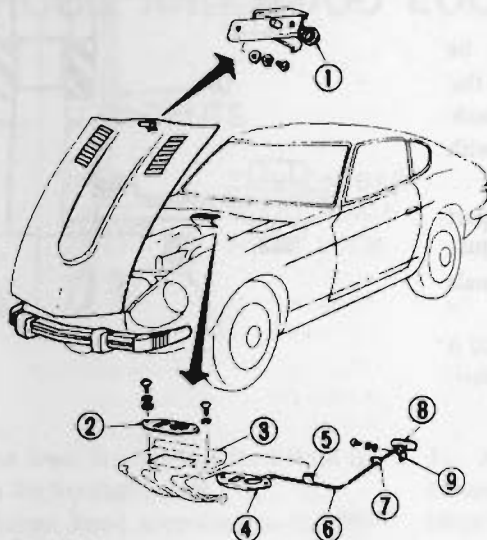

BF988A

- 1 Hood lock male part
- 2 Guide
- 3 Hood lock bracket
- 4 Hood lock female part
- 5 Clamp
- 6 Hood lock wire
- 7 Grommet
- 8 Hood lock knob
- 9 Hood lock wire bracket

Fig. BF-28 Hood lock

COWL TOP GRILLE AND FRONT FENDER

CONTENTS

COWL TOP GRILLE	BF-13	FRONT FENDER	BF-13
REMOVAL AND INSTALLATION	BF-13	REMOVAL AND INSTALLATION	BF-13

COWL TOP GRILLE

REMOVAL AND INSTALLATION

1. Open engine hood and protect front fenders with covers to prevent scratching the paint.

2. Remove windshield wiper arms and blades as a unit.
3. Remove four screws securing cowl top grille in place.
4. Take cowl top grille out in forward direction with the front end lifted. See Figure BF-29.
5. Install cowl top grille in the reverse order of removal.

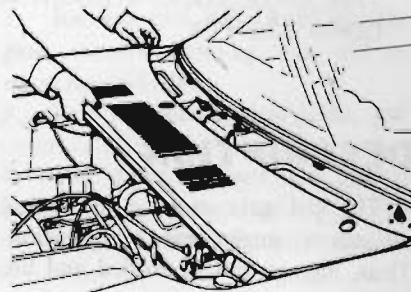

BF365A

Fig. BF-29 Removing cowl top grille

FRONT FENDER

REMOVAL AND INSTALLATION

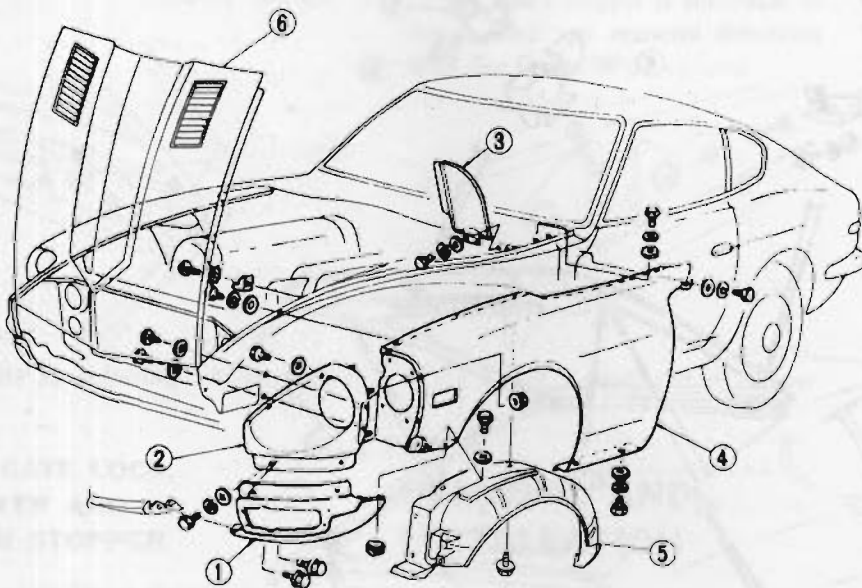

- 1 Front fender front assembly
- 2 Headlight case
- 3 Inspection lid
- 4 Front fender
- 5 Inner fender protector
- 6 Hood

BF989A

Fig. BF-30 Removing front fender

1. Remove inner fender protector.
2. Remove front bumper.
3. Remove headlight and side flasher lamp.
4. Remove two screws securing inspection lid in place, and remove inspection lid.
5. Remove windshield wiper arms and blades as a unit, and remove cowl top grille.
6. Remove screws securing front

- fender front to front apron.
7. Remove screws securing front fender front to front fender.
8. Remove screws securing front fender front to headlight case, and remove front fender front.
9. Remove nuts securing headlight case to front fender.
10. Remove screws securing headlight case to hood ledge and remove headlight case.

11. Remove screws and bolts in the following manner. Then remove front fender.

- a) Front fender to side sill (2)
- b) Front fender to front pillar (1)
- c) Front fender to cowl top (2)
- d) Hood bumper to front fender (2)
- e) Front fender to hood ledge (3)

12. Install front fender in the reverse order of removal.

TAIL GATE AND REAR PANEL FINISHER

CONTENTS

DESCRIPTION	BF-14	REMOVAL AND INSTALLATION	BF-15
ADJUSTMENT	BF-15	TAIL GATE	BF-15
TAIL GATE HINGE	BF-15	TAIL GATE LOCK AND	
TAIL GATE LOCK, STRIKER AND		STRIKER	BF-15
DOWN STOPPER	BF-15	REAR PANEL FINISHER	BF-15

DESCRIPTION

The tail gate opens upward and utilizes a single-sheet construction. Thus, luggage can be loaded and unloaded conveniently.

The tail gate stay utilizes a gas spring (filled with nitrogen gas) which increases the operating smoothness and improves the external appearance.

CAUTION:

The tail gate stay is filled with highly compressed nitrogen gas. Do not disassemble it.

In order to ease tail gate installation

and removal, split type hinges are used. The hinges are secured with both side installation screws.

A push-button type tail gate lock has been adopted. When the push-button is locked, the push-button can be depressed but not unlocked.

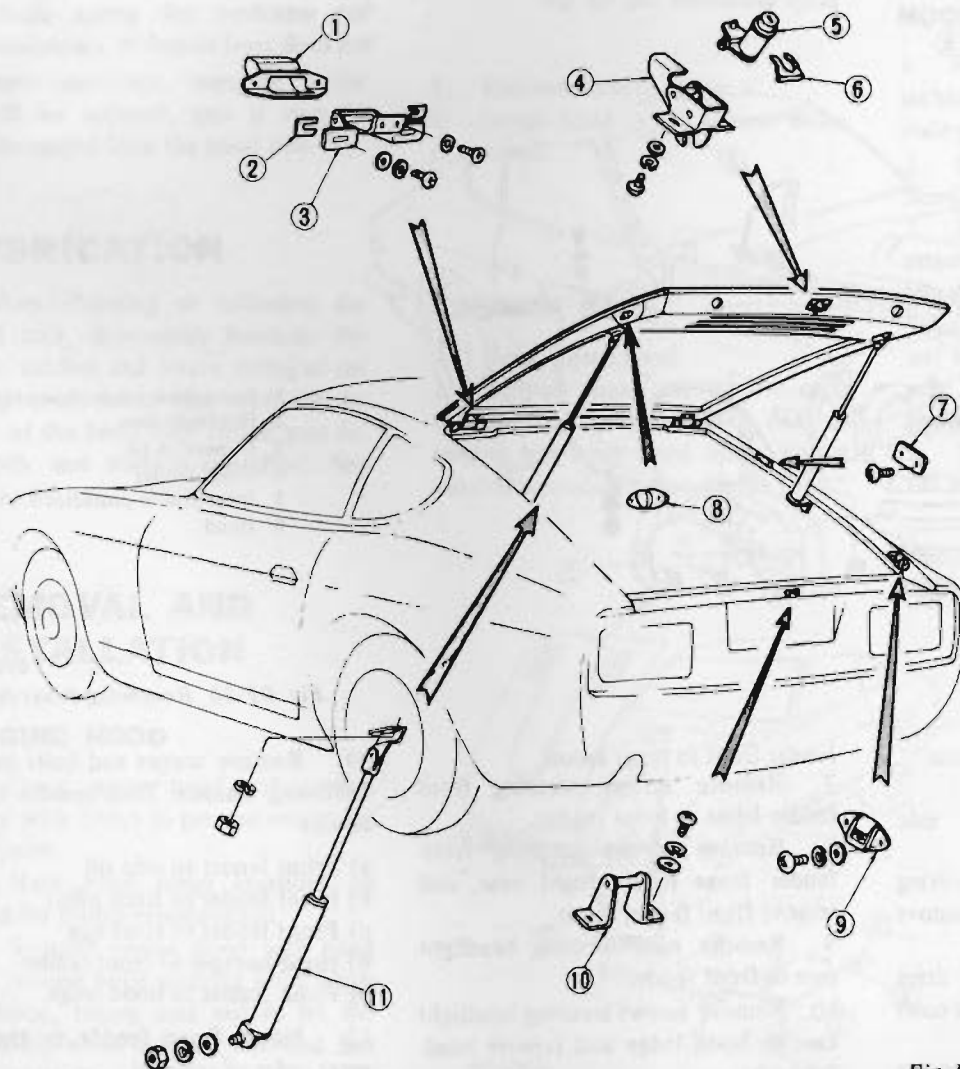

- 1 Seal cover
- 2 Shim
- 3 Tail gate hinge
- 4 Tail gate lock
- 5 Key cylinder
- 6 Clip
- 7 Bumper rubber
- 8 Dovetail
- 9 Down stopper
- 10 Striker
- 11 Tail gate stay

BF367A

Fig. BF-31 Structural view of tail gate

ADJUSTMENT

TAIL GATE HINGE

1. The fore-and-aft adjustment is correct when the clearance between tail gate and roof is held within 3.5 to 5.5 mm (0.138 to 0.217 in). If necessary, adjust it by shim(s) between hinge and body. The rear end of tail gate should be made flush with rear fender. See Figure BF-32.
2. Before making side-to-side and up-and-down adjustments of tail gate, loosen tail gate hinge attaching bolt just enough to move tail gate.
3. Move tail gate to left or right as required to obtain an equal clearance between tail gate and rear fender on both sides.
4. Move tail gate up and down to obtain a flush fit between tail gate and roof.
5. After adjustment is completed, tighten tail gate hinge attaching bolts securely.

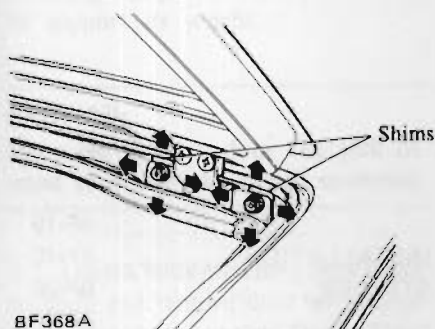
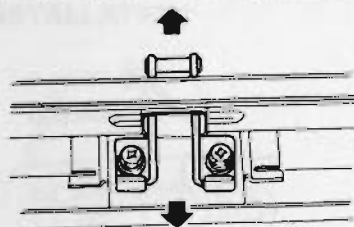

Fig. BF-32 Adjusting tail gate hinge

TAIL GATE LOCK, STRIKER AND DOWN STOPPER

1. Remove license plate lamp.
2. Temporarily loosen tail gate striker to rear panel attaching screws until they are just loose enough to move striker.
3. Move striker up or down as required until tail gate is flush with rear fenders. See Figure BF-33.
4. After correct adjustment is made, tighten screws securely.
5. Loosen tail gate lock attaching screws until they are just loose enough to move tail gate lock.
6. Open and close tail gate two or

three times to ensure that it is locked properly without binding. Then tighten attaching screws. See Figure BF-34.



BF370A
Fig. BF-33 Adjusting striker

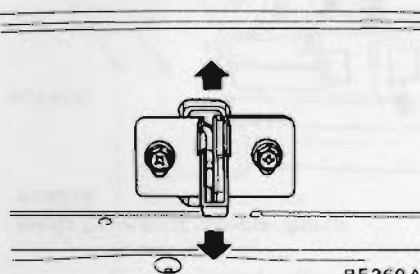

BF369A
Fig. BF-34 Adjusting tail gate lock

The down stopper is adjustable in the forward and rearward directions only. See Figure BF-35.

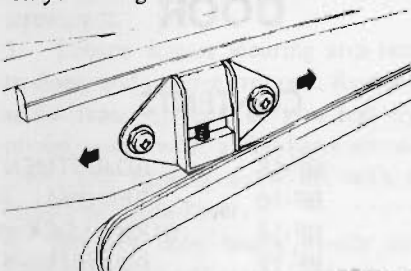

BF371A
Fig. BF-35 Adjusting down stopper

REMOVAL AND INSTALLATION

TAIL GATE

1. Open tail gate and remove tail gate stay.

CAUTION:

Place rags between roof and upper end of tail gate to avoid damaging painted surfaces.

2. Remove tail gate to hinge attaching screws.
3. Hold tail gate and remove it.

CAUTION:

Be careful not to scratch tail gate stay when installing. A scratched stay may cause gas leakage.

TAIL GATE LOCK AND STRIKER

1. Remove lock from tail gate.
2. Remove trim, insert hand into the gate, remove retaining clip, and remove key cylinder.
3. Remove license plate lamp, and remove striker.
4. The down stopper and rubber bumper can be removed simply by loosening the installation screws.

REAR PANEL FINISHER

1. Remove rear panel trim.
2. Disconnect rear combination lamp connector.
3. Remove nuts securing rear combination lamp to body. See Figure BF-36.

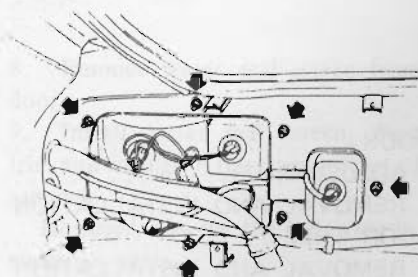

BF372A
Fig. BF-36 Removing nuts attaching rear combination lamp to body

4. Remove screws securing license lamp in place, and detach lamp. See Figure BF-37.

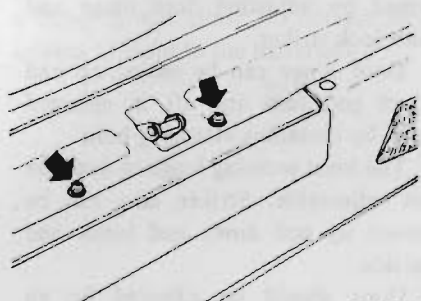

BF373A
Fig. BF-37 Removing license lamp

5. Remove plastic rivets securing rear panel finisher to rear panel. See

Figure BF-38.

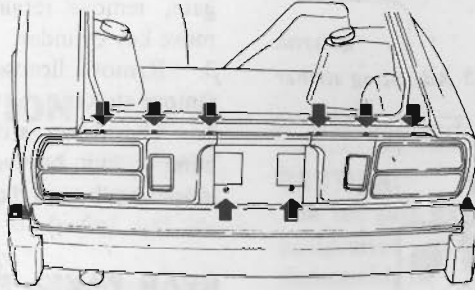
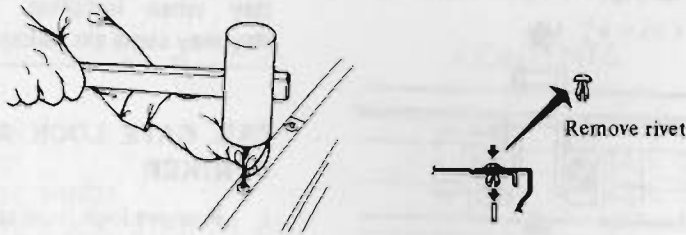

BF990A

Fig. BF-38 Removing rivets

6. Remove finisher and rear combination lamp as a unit.

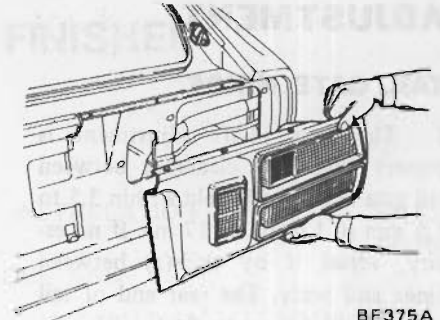

BF375A

Fig. BF-39 Removing finisher and combination lamp assembly

7. Remove screws securing rear combination lamp to finisher, and remove rear combination lamp.

8. Remove screws securing rim to finisher, and remove rim.

CAUTION:
Be careful not to scratch the painted surface of body, finisher, etc. with tool or the like.

9. Install finisher in the reverse order of removal.

DOOR

CONTENTS

DOOR	BF-16	ADJUSTMENT	BF-19
ADJUSTMENT	BF-16	REMOVAL AND INSTALLATION	BF-19
REMOVAL AND INSTALLATION	BF-17	DOOR LOCK AND STRIKER	BF-20
DOOR TRIM	BF-17	ADJUSTMENT	BF-21
REMOVAL AND INSTALLATION	BF-17	REMOVAL AND INSTALLATION	BF-21
DOOR WINDOW GLASS AND REGULATOR ..	BF-18	BODY SIDE AND DOOR WEATHERSTRIPS...	BF-22

DOOR

ADJUSTMENT

Proper door alignment can be obtained by adjusting door hinge and door lock striker.

Door hinge can be moved up and down and fore and aft in enlarged holes by loosening attaching bolts.

The bolts securing hinge to door are not adjustable. Striker also can be moved up and down and inside and outside.

Door should be adjusted for an even and parallel fit with the door opening and surrounding body panels.

CAUTION:
Be careful not to distort or mar door and surrounding body panels when adjusting. See Figures BF-40 and BF-41.

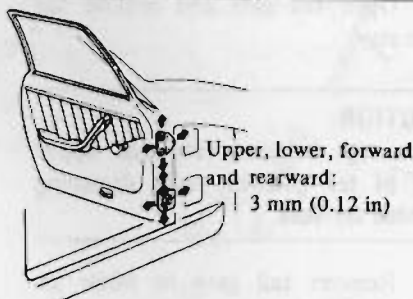

BF653A

Fig. BF-40 Adjusting door hinge

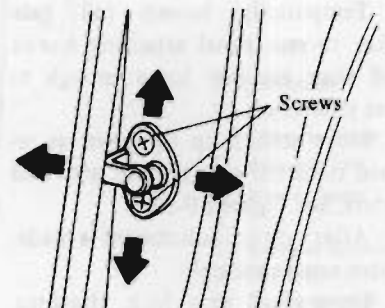

BF991A

Fig. BF-41 Adjusting door lock striker

Front door hinge can be adjusted without removing front fender by using Door Hinge Wrench ST08720000. See Figure BF-42.

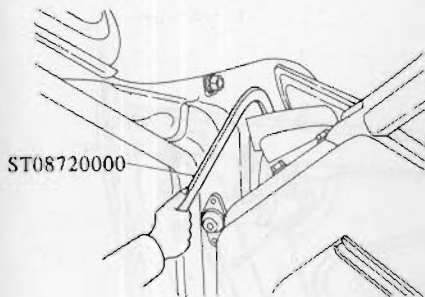

BF992A

Fig. BF-42 Adjusting door hinge

REMOVAL AND INSTALLATION

1. With door in full open position, place a garage jack or stand under door to support its weight.

CAUTION:

Place rag between door and jack or stand to protect door from scratches.

2. Loosen bolts attaching door hinge to body and remove door with hinge from the car by using Door Hinge wrench ST08720000. See Figure BF-42.

3. Untighten bolts attaching hinge to door and remove hinge.

4. Install door in the reverse order of removal.

DOOR TRIM

REMOVAL AND INSTALLATION

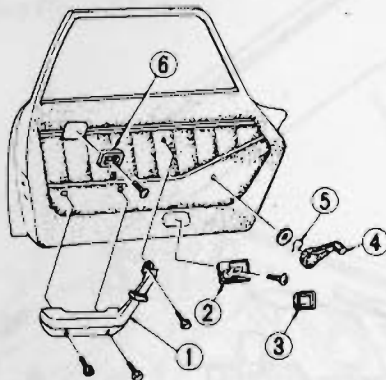

BF485A

- 1 Arm rest
- 2 Escutcheon
- 3 Escutcheon cover
- 4 Door regulator handle
- 5 Retaining spring
- 6 Rear inside handle escutcheon (GS30 2 + 2 seater only)

Fig. BF-43 Removing door trim

1. Open door and leave it open.
2. Remove door lock knob by unscrewing it.
3. Loosen screws securing arm rest to door, and remove arm rest. Remove screw from tip end of arm rest by prying cover with a flat-head screwdriver and backing screw off with a cross-head screwdriver.
4. Remove door inside handle escutcheon cover and screw, and detach escutcheon.

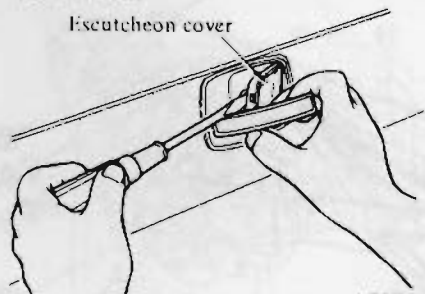

BF654A

Fig. BF-44 Removing escutcheon cover

5. Remove rear inside handle escutcheon and rear inside handle. (GS30 2 + 2 seater only)

6. Remove spring retaining regulator handle in place, and detach regulator handle and washer. See Figure BF-43.

7. Using a screwdriver, remove door finisher retaining clips from door, and remove door trim. See Figure BF-45.

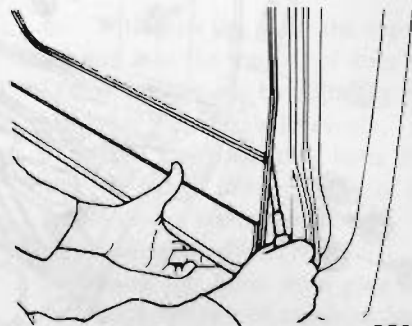

BF086

Fig. BF-45 Removing door trim

8. Remove water seal screen from door.

9. Install water seal screen, door trim and fittings in the reverse order of removal.

However, observe the following installation notes.

(1) When water seal screen is to be installed, it must be replaced with a new one if broken or suspected of leaking.

(2) When installing door regulator handle, make sure that knob is faced forward with side window glass completely closed.

(3) When cleaning door finisher, use a damp or wet cloth; do not use any solvent harmful to the material.

DOOR WINDOW GLASS AND REGULATOR

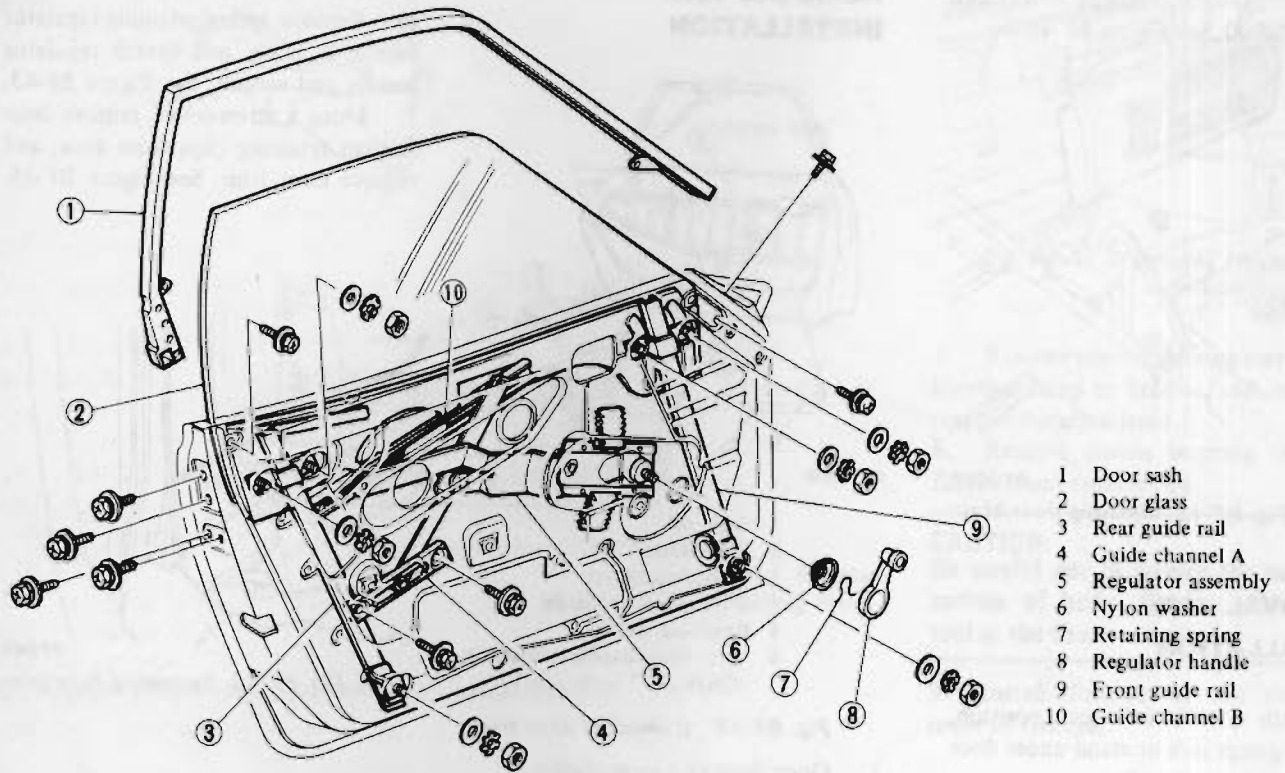

- 1 Door sash
- 2 Door glass
- 3 Rear guide rail
- 4 Guide channel A
- 5 Regulator assembly
- 6 Nylon washer
- 7 Retaining spring
- 8 Regulator handle
- 9 Front guide rail
- 10 Guide channel B

BF993A

Fig. BF-46 Door window glass and regulator for S30 (2 seater)

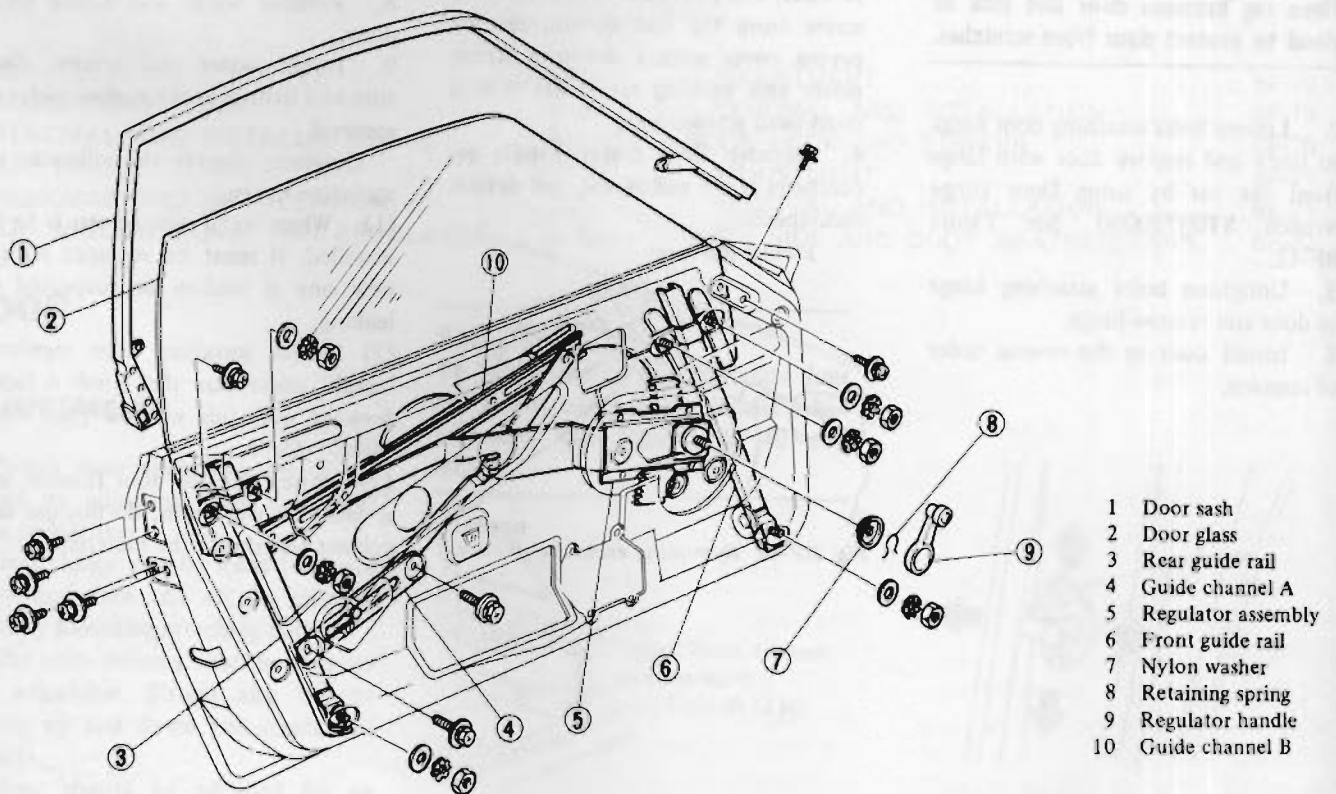

- 1 Door sash
- 2 Door glass
- 3 Rear guide rail
- 4 Guide channel A
- 5 Regulator assembly
- 6 Front guide rail
- 7 Nylon washer
- 8 Retaining spring
- 9 Regulator handle
- 10 Guide channel B

BF994A

Fig. BF-47 Door window glass and regulator for GS30 (2 + 2 seater)

ADJUSTMENT

Door glass alignment can be accomplished by adjusting front and rear guide rails and guide channel.

1. To obtain proper alignment of

glass, temporarily loosen front and rear guide rails.

For lower adjusting bolt, tighten it all the way. Then return four turns and secure lock nut at that position. See Figure BF-48.

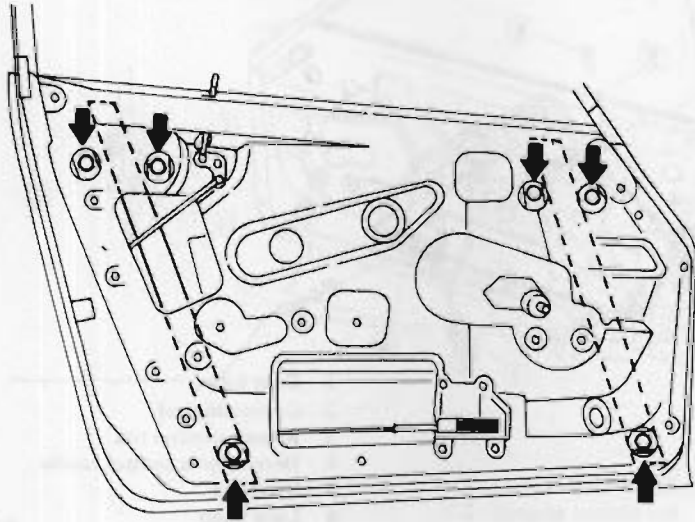

BF995A

Fig. BF-48 Guide rail adjusting mechanism

2. With glass in the up position, adjust guide rail upper adjusting bolts so that the clearance between outside door panel and outside glass face is 22 to 24 mm (0.87 to 0.94 in). Raise and lower glass to assure a fit. See Figure BF-49.

The sideways free play of glass can be adjusted by moving front and rear guide rails fore and aft. See Figure BF-50.

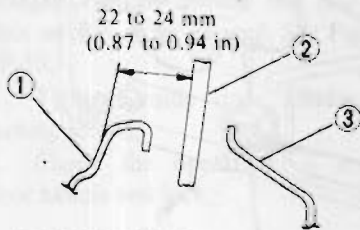

- 1 Outside door panel
- 2 Glass
- 3 Inside door panel

BF996A

Fig. BF-49 Proper clearance between outside door panel and glass

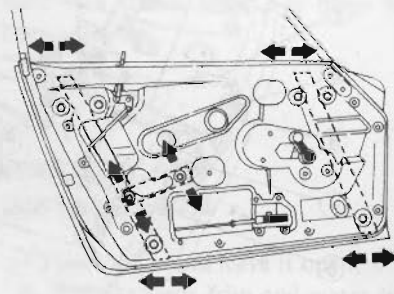

BF997A

Fig. BF-50 Adjusting front and rear guide rails

3. Make sure that outside door weatherstrip makes proper contact with door glass when door glass is raised and lowered.

4. With glass up, adjust glass in parallel with the top rail of door sash by moving guide channel A up and down.

5. Adjustment of guide channel A can be accomplished by the following procedure:

When door glass is as in picture (A) of Figure BF-51, move guide channel up. Move it down if as in picture (B).

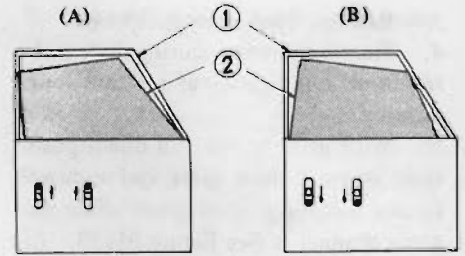

- 1 Door sash
- 2 Door glass

BF 479

Fig. BF-51 Adjusting guide channel A

6. With glass up, move the top edge of glass into the top rail of door sash. Obtain a tight seal by adjusting guide rail lower adjusting bolts evenly.

7. Turn lower adjusting bolts clockwise to release the top edge of glass from door sash inside welt and counterclockwise to tighten.

8. Raise and lower door glass to be sure the operation of regulator glass is smooth. The operating force of regulator handle should be less than 3.5 kg (7.7 lb) at the knob of regulator handle.

If proper operating force is still not obtained, adjust regulator mechanism according to the following procedures:

- (1) Lubricate guide rollers, guide rails and regulator linkage.
- (2) Perform outside and inside door weatherstrip-to-door glass adjustment.
- (3) Adjust guide rails in parallel.

REMOVAL AND INSTALLATION

- 1. Lower door glass.
- 2. Remove arm rest, regulator handle, inside door handle escutcheon, door lock knob, rear inside handle (GS30 2 + 2 seater only), door trim and water seat screen. See Figure BF-52.

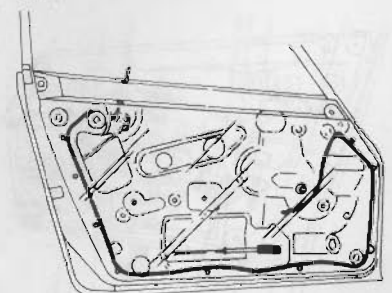

BF998A

Fig. BF-52 Removing door trim

3. Remove door outer molding.
4. Remove screws securing door sash to door inner panel and draw door sash up.
5. With glass in the full down position, support door glass and remove screws attaching glass back plate to guide channel B. See Figure BF-53.

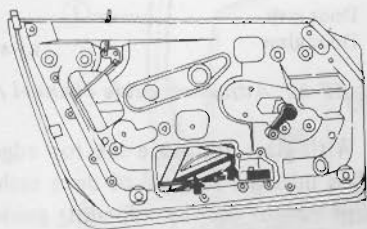

BF999A

Fig. BF-53 Removing screws attaching glass back plate to guide channel B

6. Loosen bolts adjusting front and rear guide rail and raise door glass and draw it upwards.
7. Remove guide rails from door. See Figure BF-54.

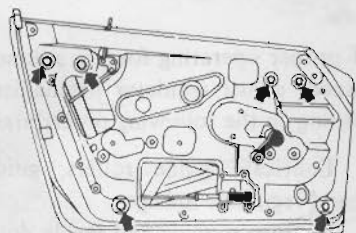

BF1000A

Fig. BF-54 Removing guide rail

8. Remove screws attaching guide channel A, regulator arm base and regulator base and then remove them through the lower opening of inside door panel. See Figure BF-55.

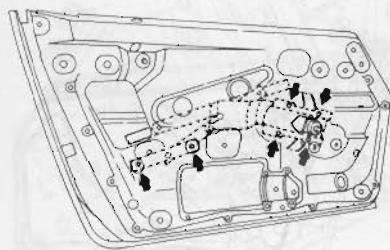

BF001B

Fig. BF-55 Removing regulator assembly

9. Install regulator assembly, guide rails, and door glass in the everse order of removal.

DOOR LOCK AND STRIKER

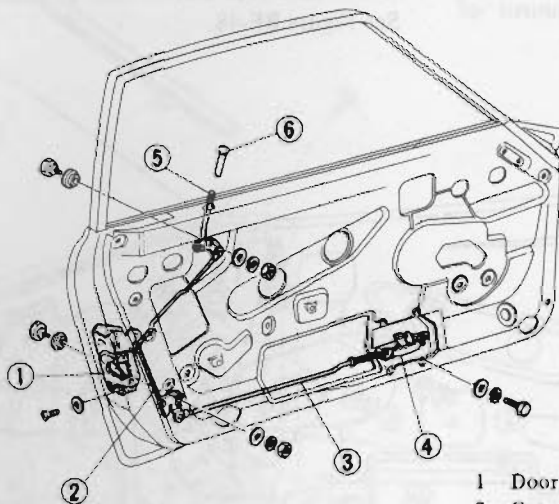

- 1 Door lock
- 2 Connecting rod
- 3 Remote control rod
- 4 Door remote control handle
- 5 Knob rod
- 6 Lock knob

BF002B

Fig. BF-56 Door lock mechanism for S30 (2 seater)

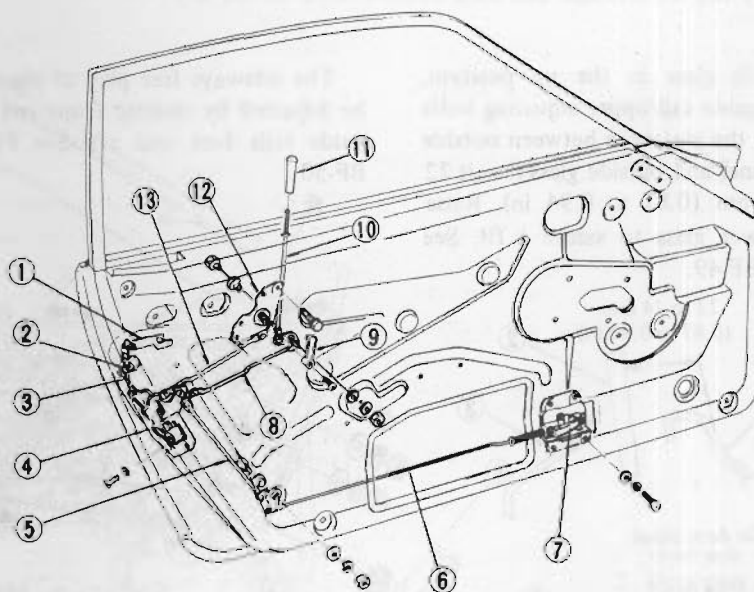

- 1 Outside door handle
- 2 Key cylinder
- 3 Outside door handle rod
- 4 Door lock
- 5 Connecting rod
- 6 Remote control rod
- 7 Door remote control handle
- 8 Rod
- 9 Rear inside handle
- 10 Knob rod
- 11 Lock knob
- 12 Rear inside handle bracket
- 13 Rod

BF003B

Fig. BF-57 Door lock mechanism for GS30 (2 + 2 seater)

ADJUSTMENT

Outside door handle

Outside door handle adjustment can be accomplished by adjusting the clearance between outside door lock

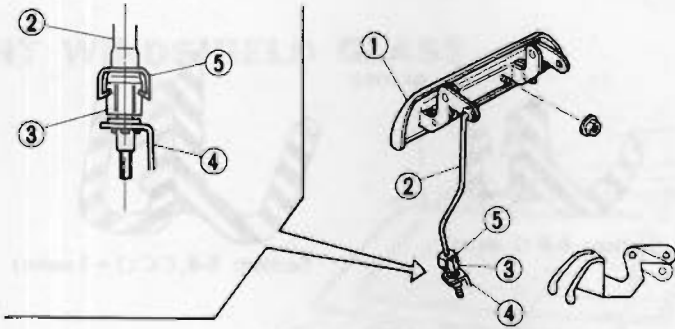

- 1 Outside door handle
- 2 Remote control rod
- 3 Adjusting nut (Nylon)
- 4 Door lock lever
- 5 Clip

BF004B

Fig. BF-58 Adjusting outside door handle free play

Inside door handle

1. Partially loosen inside door handle attaching screws.
2. With inside door lock knob set on (closed), move inside door handle in elongated holes toward the rear of door until it stops moving. See Figure BF-59.
3. Tighten inside door handle attaching screws.
4. Check the operation of inside door handle and lock.

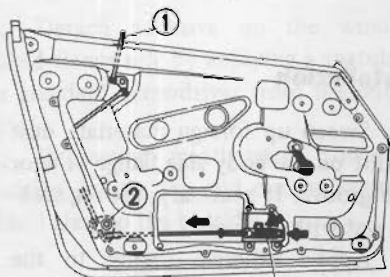

- 1 Inside door lock knob
- 2 Bell-crank
- 3 Door inside handle

BF005B

Fig. BF-59 Adjusting inside door handle

lever and adjusting nut (nylon) located on outside door handle rod.

To adjust outside door handle, turn adjusting nut clockwise or counter-clockwise to obtain clearance of 0 to 1.0 mm (0 to 0.039 in). See Figure BF-58.

7. Loosen screws securing rear guide rail and remove rear guide rail.
8. Loosen screw attaching bell crank with lock knob rod and remote control knob.
9. Remove key cylinder retaining clip, and remove key cylinder.
10. Loosen nuts attaching outside door handle and remove handle with rod. See Figure BF-60.

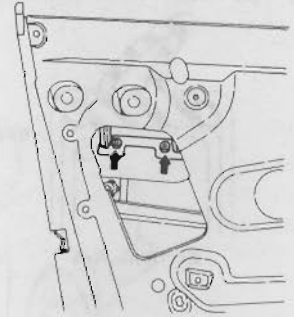

BF006B

Fig. BF-60 Removing outside door handle

11. Remove door lock installation screws. Then, remove door lock from opening on the inside door panel.

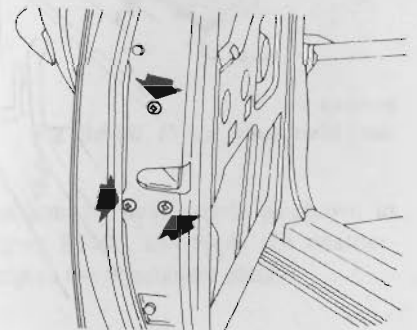

BF466

Fig. BF-61 Removing door lock assembly

Door lock striker

Door lock striker can be moved from side to side and up and down to align it with door lock latch. Adjust door lock striker after door hinge has been adjusted.

REMOVAL AND INSTALLATION

1. Open door and leave it open.
2. Remove door trim and water seal screen. Refer to page BF-17 for Removal and Installation of Door Trim.
3. With glass down, remove door sash.
4. Draw out window glass. Refer to Door Window Glass and Regulator section.
5. Remove inside door handle and bell-crank attaching screws.
6. Remove rear remote control bracket securing bolts and remove rear inside handle. (GS30 2 + 2 seater only)

12. Loosen door lock striker attaching screws and remove door lock from body. See Figure BF-62.

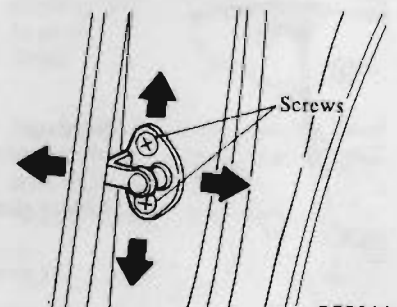

BF991A

Fig. BF-62 Removing door lock striker

13. Install door lock mechanism in the reverse order of removal and apply small amount of multi-purpose grease to all movable surfaces of door lock assembly to obtain smooth operation.

CAUTION:

If door is heated over 80°C (176°F) when repainting door, nylon nut should be removed to avoid deformation.

Note: Check return springs, actuating levers and other component parts for deformation, fatigue or rusting. Faulty parts must be replaced.

BODY SIDE AND DOOR WEATHERSTRIPS

Body side weatherstrip is attached to body side flange. Door weatherstrip

is attached to door sash. See Figure BF-63.

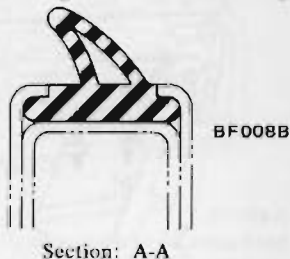

Section: A-A



Section: B-B (2 seater)



Section: B-B, C-C (2 + 2 seater)

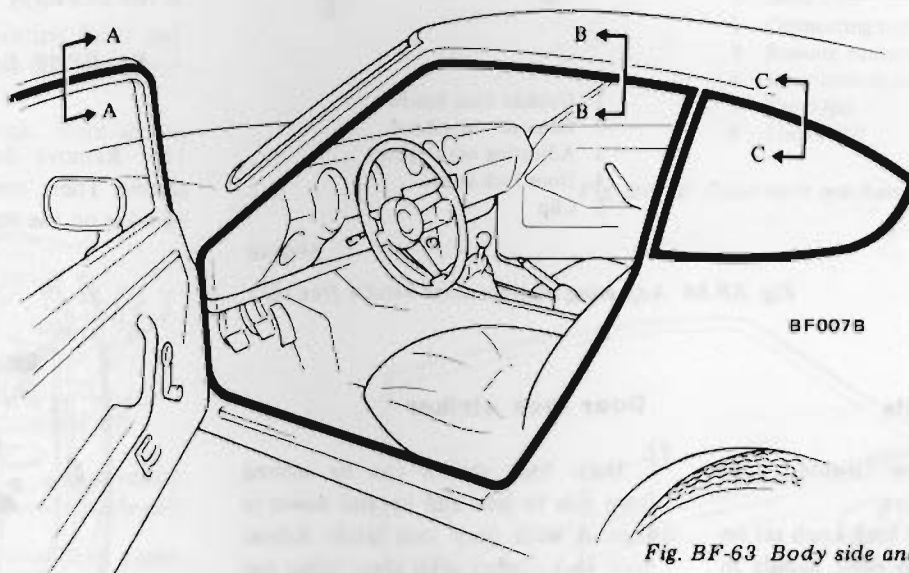
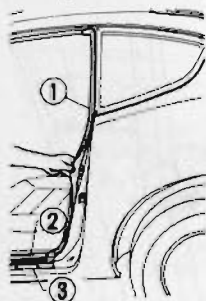

Fig. BF-63 Body side and door weatherstrips

Removal

Body side weatherstrip:

Loosen screws retaining scuff plate, and remove body side weatherstrip assembly by pulling out by hand. See Figure BF-64.



- 1 Body side weatherstrip
- 2 Scuff plate
- 3 Kicking plate

BF010B

Fig. BF-64 Removing body side weatherstrip

Door weatherstrip:

1. Remove rivets retaining door weatherstrip from door by prying off with standard screwdriver. See Figure BF-65.

2. Pull out door weatherstrip from groove of door sash.

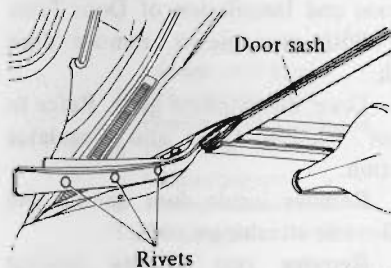

Fig. BF-65 Prying off rivets

Installation

1. Sweep up foreign materials, dust or dirt on the body side flange or door sash groove. If necessary, use rag soaking wet with thinner.
2. Apply adhesive evenly to the weatherstrip and the portion where weatherstrip may be seated.
3. Position weatherstrip and bite body side flange with welt or install rivets in position.

WINDSHIELD GLASS

CONTENTS

FRONT WINDSHIELD GLASS	BF-23	SIDE WINDOW	BF-24
REMOVAL	BF-23	TAIL GATE GLASS	BF-25
INSTALLATION	BF-23		

FRONT WINDSHIELD GLASS

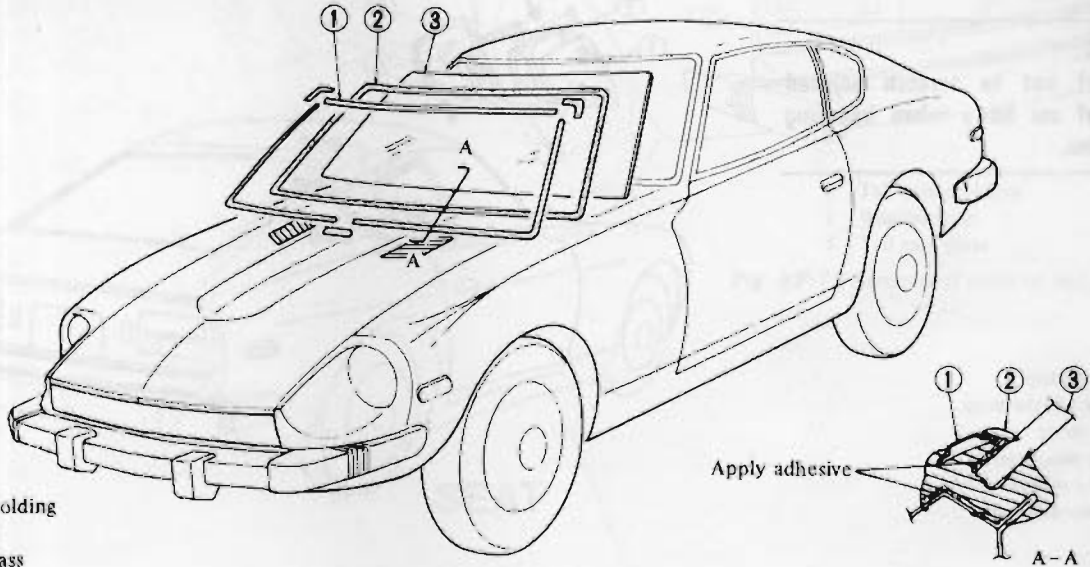

- 1 Windshield molding
- 2 Weatherstrip
- 3 Windshield glass

Apply adhesive

A-A

BF012B

Fig. BF-66 Front windshield glass

REMOVAL

1. Remove inside rearview mirror.
2. Remove instrument panel garnish.
3. Remove windshield wiper blades together with arms.
4. Remove windshield molding.

CAUTION:

Be careful not to deform the molding.

5. Detach adhesive on the windshield flange side by applying a spatula or standard screwdriver from the outside.
6. Depressing weatherstrip toward outside, lightly tap and remove windshield glass to the outside.



BF390A

Fig. BF-67 Removing front windshield glass

INSTALLATION

CAUTION:

Care should be exercised to make certain glass does not strike body metal during installation. Edge chips can lead to future breaks.

1. For installation, use string and spatula as shown in Figure BF-68.
2. Apply adhesive to appropriate

portions of weatherstrip as shown in Figure BF-66, and apply the weatherstrip to the windshield glass.

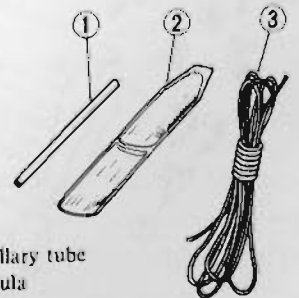

- 1 Capillary tube
- 2 Spatula
- 3 String

BF391A

Fig. BF-68 Tools for installation of windshield glass

3. Place string into weatherstrip groove.
4. Set windshield glass in the windshield flange from the outside, and put the string into the compartment side.

Note: Windshield glass removal must be started from the upper side portion.

Note: The operation should be carried out by two persons; one works outside and the other inside.

5. Pull the string (person working inside) in such a manner that the weatherstrip correctly engages with the flange. At the same time, lightly

tap the glass (person working outside) by hand and assist the person working inside.

Note: If the weatherstrip is not fitted into the flange correctly but mounted on the flange, correctly fit the weatherstrip into the flange by the use of a spatula.

6. Tap the overall glass area lightly to settle the weatherstrip down evenly and tightly on the flange.

7. Apply adhesive to the entire periphery.

8. Install windshield molding.

9. Install windshield wiper blades and arms.

10. Install instrument panel garnish.

11. Install inside rearview mirror.

SIDE WINDOW

CAUTION:

Be careful not to scratch painted surfaces of car body when handling side window.

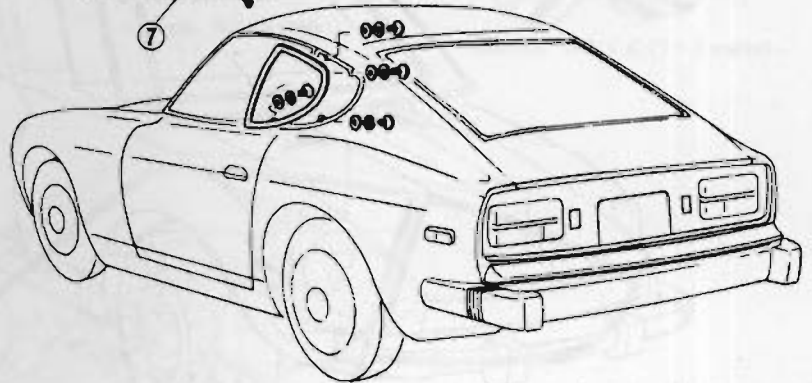
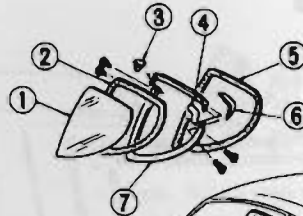

- 1 Glass
- 2 Weatherstrip
- 3 Upper weatherstrip
- 4 Joint cover
- 5 Outer weatherstrip
- 6 Sealing rubber
- 7 Side window sash

BF014B

Fig. BF-69 Structural view of side window for S30 (2 seater)

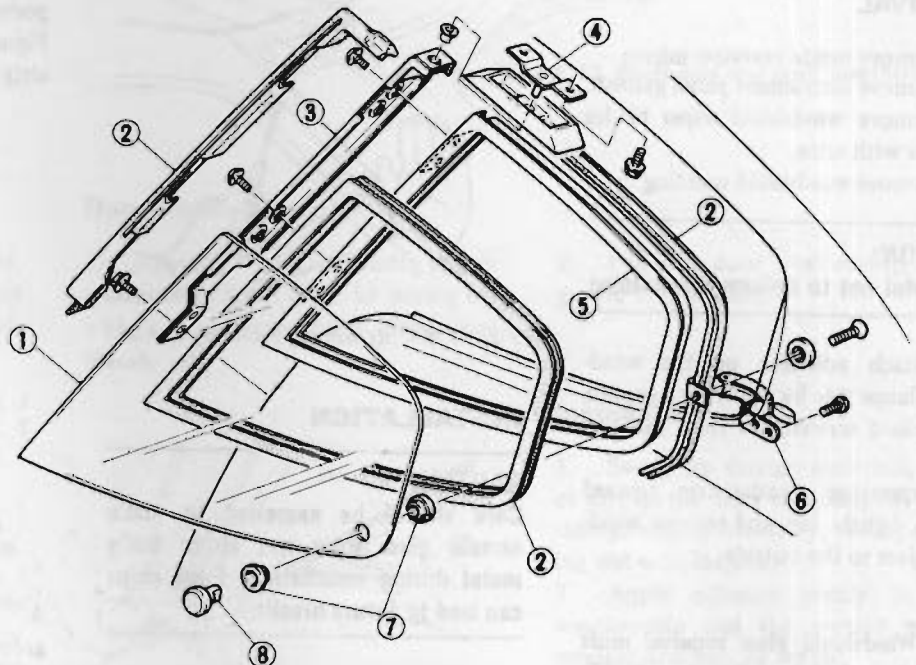

- 1 Side window glass
- 2 Side window weatherstrip
- 3 Center pillar
- 4 Side window upper bracket
- 5 Side window sash
- 6 Side window handle
- 7 Rubber washer
- 8 Finisher nut

BF386B

Fig. BF-70 Structural view of side window for GS30 (2 + 2 seater)

TAIL GATE GLASS

The instructions for windshield glass apply also to tail gate glass removal and installation, with the exception that sealing agent is used rather than adhesive.

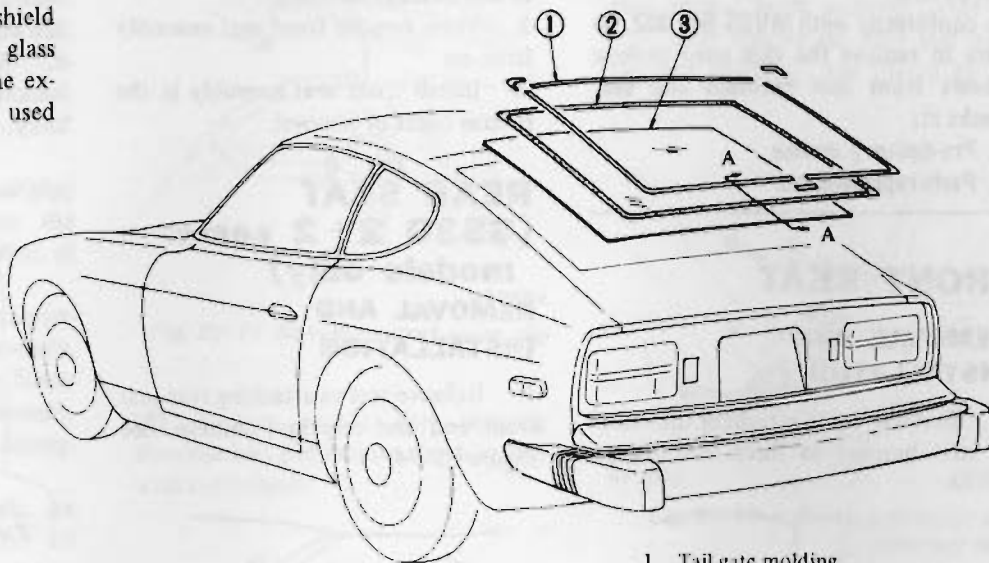
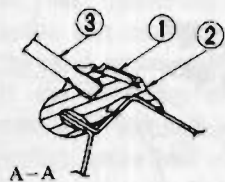

- 1 Tail gate molding
- 2 Weatherstrip
- 3 Tail gate glass

BF015B

Fig. BF-71 Structural view of tail gate glass

SEAT

CONTENTS

DESCRIPTION	BF-25	REAR SEAT (GS30 2 + 2 seater models only)	BF-26
FRONT SEAT	BF-26	REMOVAL AND INSTALLATION	BF-26
REMOVAL AND INSTALLATION	BF-26		

DESCRIPTION

The front seats are a separate, bucket type which is equipped with a high seatback. The high seatback is combined with a head rest.

The reclining seat can be tilted 6° forward and 36° backward, from the neutral position, with a pitch of 3° by lifting the tilt control lever located on the door side of the seat cushion.

These seats can also be moved 180 mm (7.09 in) in the fore-and-aft direction with a pitch of 20 mm (0.79 in).

The seatback of rear seat can be folded flush to the rear floor by releasing seatback lock. (GS30 2 + 2 seater only)

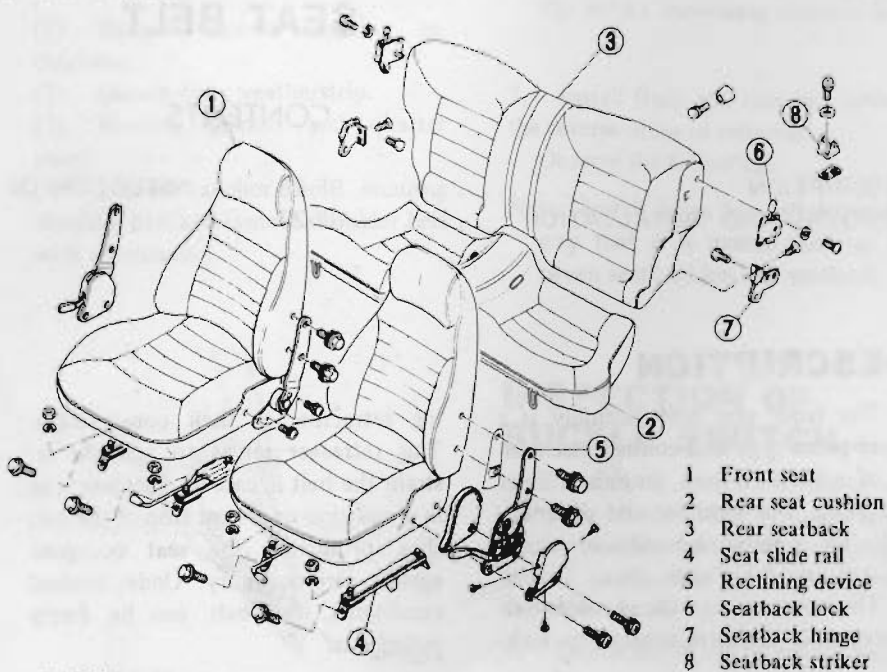

BF016B

Fig. BF-72 Structural view of front and rear seats

CAUTION:

In conformity with MVSS No. 302, be sure to remove the thin polyethylene covers from seat cushions and seat backs at:

- a. Pre-delivery service
- b. Parts replacements

FRONT SEAT

REMOVAL AND INSTALLATION

1. Remove bolts attaching the front of seat bracket to floor. See Figure BF-73.

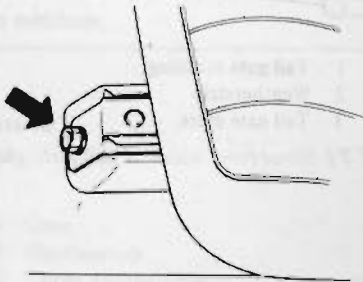

BF488A

Fig. BF-73 Removing front attaching bolts of front seat

- 2. Remove bolts attaching the rear of seat bracket to floor.
- 3. Then remove front seat assembly from car.
- 4. Install front seat assembly in the reverse order of removal.

**REAR SEAT
(GS30 2+2 seater models only)**

REMOVAL AND INSTALLATION

1. Remove screws attaching rear seat front end and rear seat cushion. See Figure BF-74.

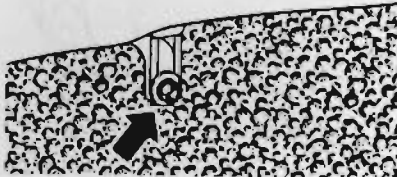
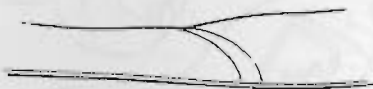

BF489A

Fig. BF-74 Removing rear seat cushion

- 2. Fold seatback forward by releasing seatback lock, and remove screws attaching rear floor mat.
- 3. Remove bolts attaching rear seatback to body and remove it from body. See Figure BF-75.

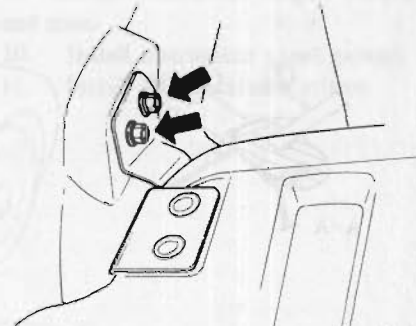

BF490A

Fig. BF-75 Removing rear seatback

4. Install rear seat cushion and seatback in the reverse order of removal.

SEAT BELT

CONTENTS

DESCRIPTION	BF-26	INSPECTION OF BUCKLE SWITCH	BF-27
REMOVAL AND INSTALLATION	BF-27		

DESCRIPTION

The front seat belt assembly is a three-point type and consists essentially of a shoulder belt, outer and inner lap belts. The shoulder and outer lap belts are a combined unit and cannot be separated from each other.

The outer lap and the shoulder belt incorporate sensitive emergency lock-

ing retractors in their construction. This retractor serves to securely restrain the belt in case of emergency, as in a collision or abrupt stop of the car, thus protecting the seat occupant against serious injury. Under normal conditions, the belt can be freely pulled out.

The inner lap belt is a flexible wire combined with a buckle. The buckle includes a switch which functions as a seat belt warning device.

The rear seat belt is a two point type. It includes an automatic belt locking-retractor device.

CAUTION:

- a. In conformity with MVSS No. 302, be sure to remove the thin polyethylene covers from seat belts at:
 - (1) Pre-delivery service
 - (2) Parts replacements
- b. If the car has been in a collision or has overturned, replace the entire belt assembly, regardless of the exact nature of accident.
- c. If the condition of any component of a seat belt is questionable, replace entire belt assembly. Never attempt to repair belt components.
- d. If webbing is cut, frayed, or damaged, replace belt assembly.
- e. Do not spill drinks, oil, etc. on an inner lap belt buckle. Never oil tongue and buckle.
- f. Use only a genuine Nissan seat belt assembly.

REMOVAL AND INSTALLATION

1. Disconnect battery ground cable.
2. Disconnect buckle switch harness at connector.
3. Loosen bolt holding inner lap belt and remove inner lap belt. See Figure BF-76.

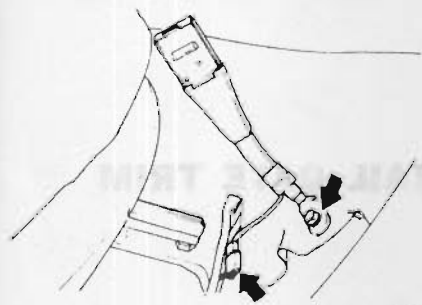

BE176A

Fig. BF-76 Removing inner lap belt

4. Removing shoulder belt

S30 models

- (1) Remove synthetic resin clip and strut cover.

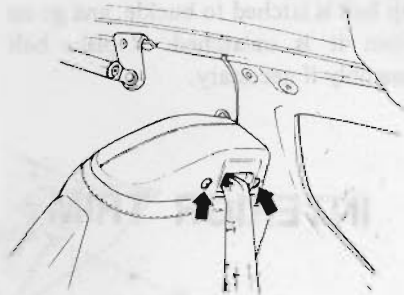

BF658A

Fig. BF-77 Removing strut cover clip

- (2) Loosen anchor bolt securing shoulder belt and remove shoulder belt with escutcheon.

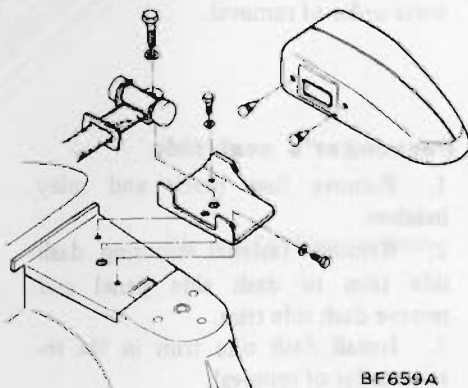

BF659A

Fig. BF-78 Removing shoulder belt (for S30 2 seater models)

GS30 2 + 2 seater models

- (1) Remove screws securing escutcheon.
- (2) Detach door weatherstrip.
- (3) Remove garnish and quarter panel.
- (4) Loosen anchor bolt securing shoulder belt and remove shoulder belt with escutcheon.

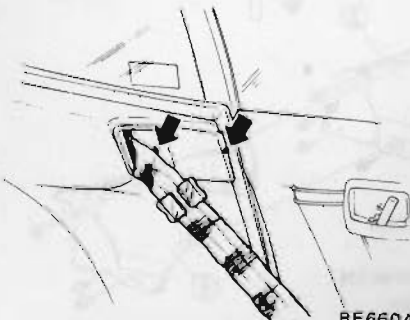

BF660A

Fig. BF-79 Removing shoulder belt (for GS30 2 + 2 seater models)

5. Remove E.L.R. cover and loosen two anchor bolts securing outer lap belt, then remove shoulder and outer lap belt assembly. See Figure BF-80.

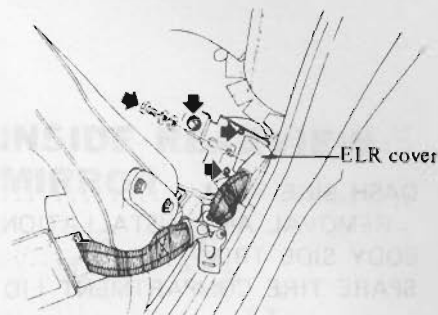

BF398A

Fig. BF-80 Removing shoulder and outer lap belts

6. Removing rear seat belt.

Remove seat cushion and seatback, then loosen anchor bolts securing rear seat belts and remove rear seat belts. See Figure BF-81.

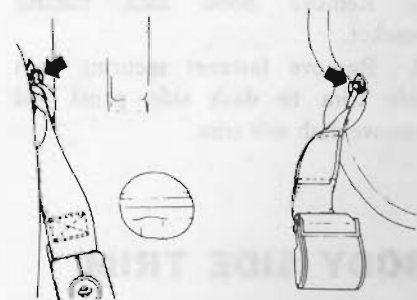

BF503A

Fig. BF-81 Removing rear seat belts

7. Install front and rear seat belts in the reverse order of removal.

Observe the following.

Note: Install inner lap belt in such a way that it is routed midway between seat cushion and seatback.

INSPECTION OF BUCKLE SWITCH

The buckle switch contacts are normally closed. When tongue is latched to buckle, the tip end of tongue pushes push rod, thus opening the switch contacts.

1. Disconnect battery ground cable.
2. Disconnect buckle switch wire harness.

3. Check buckle switch for proper operation, using a test light. The light should go out when tongue of outer

lap belt is latched to buckle, and go on when it is unlatched. Replace belt assembly if necessary.

Note: When checking buckle switch operation, make sure that power is held below 16 volts and 13mA.

INTERIOR TRIM

CONTENTS

DASH SIDE TRIM	BF-28	TAIL GATE TRIM	BF-28
REMOVAL AND INSTALLATION	BF-28	FLOOR CONSOLE	BF-29
BODY SIDE TRIM	BF-28	REMOVAL AND INSTALLATION	BF-29
SPARE TIRE COMPARTMENT LID	BF-28	INSIDE REARVIEW MIRROR	BF-29

DASH SIDE TRIM

REMOVAL AND INSTALLATION

Driver's seat side

1. Remove two flasher units (for turn signal and hazard).
2. Remove hood lock control bracket.
3. Remove fastener securing dash side trim to dash side panel and remove dash side trim.

4. Install dash side trim in the reverse order of removal.

Passenger's seat side

1. Remove fuse block and relay bracket.
2. Remove fastener securing dash side trim to dash side panel and remove dash side trim.
3. Install dash side trim in the reverse order of removal.

SPARE TIRE COMPARTMENT LID

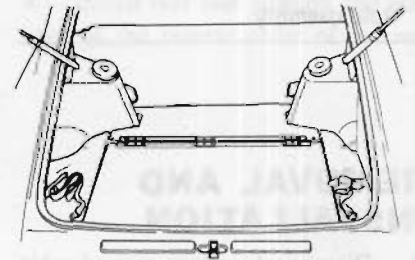

BF018B

Fig. BF-83 Spare tire compartment lid

BODY SIDE TRIM

Push in the center of the fastener with skinny bar. Fastener can be

pulled out easily. See Figure BF-38.

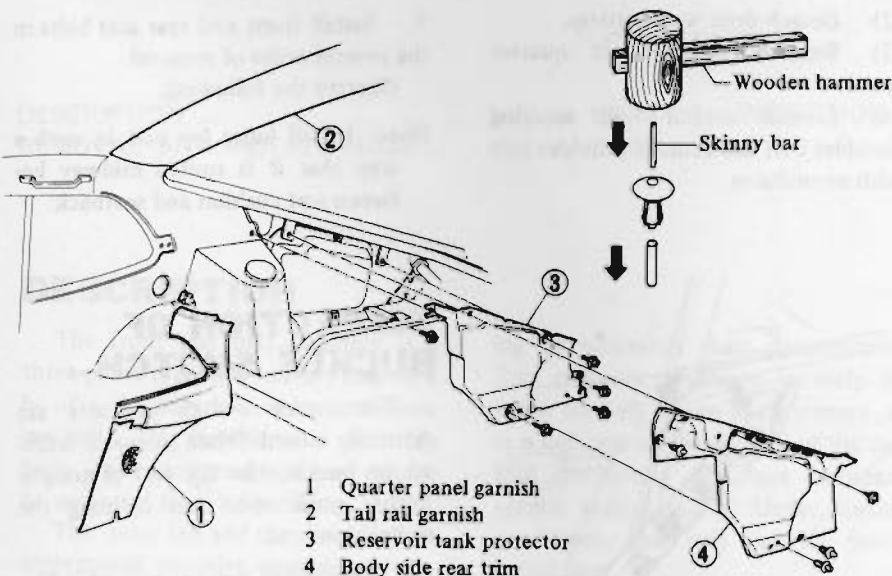

- 1 Quarter panel garnish
- 2 Tail rail garnish
- 3 Reservoir tank protector
- 4 Body side rear trim

BF024B

Fig. BF-82 Body side trim (2 + 2 seater)

TAIL GATE TRIM

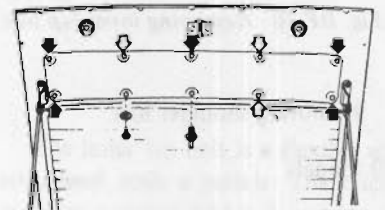

BF401A

Fig. BF-84 Tail gate trim

FLOOR CONSOLE

REMOVAL AND INSTALLATION

1. Remove five screws securing floor console in place.
2. Disconnect wiring harnesses from console.
3. Install floor console in the reverse order of removal.

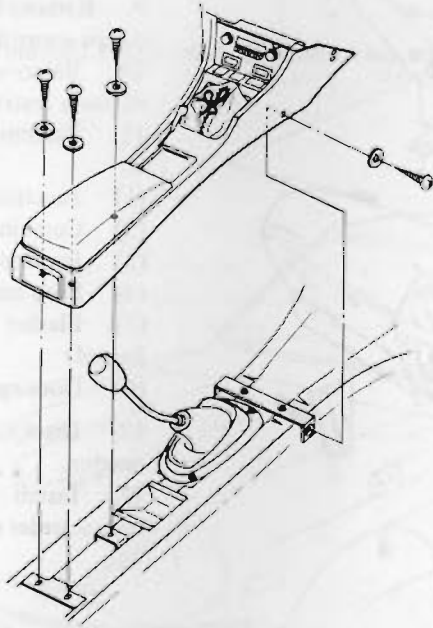

BF019B

Fig. BF-85 Floor console

INSIDE REARVIEW MIRROR

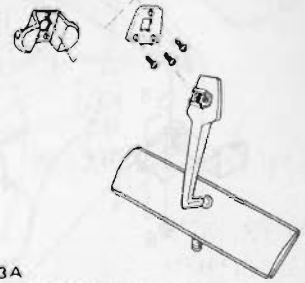

BF403A

Fig. BF-86 Inside rearview mirror

INSTRUMENT PANEL

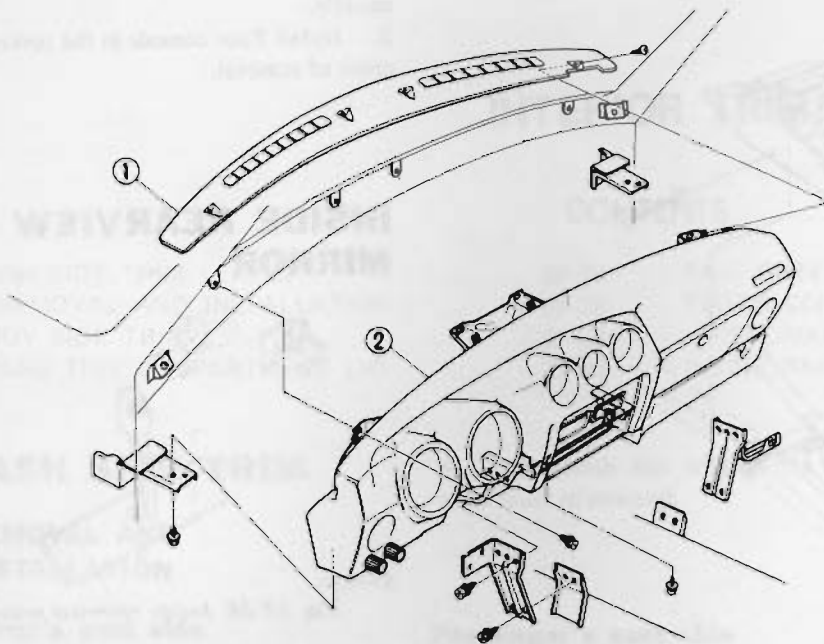

- 1 Instrument garnish
- 2 Instrument panel with pad

BF020B

Fig. BF-87 Instrument panel

REMOVAL AND INSTALLATION

1. Remove cable from battery terminal.
2. Remove horn pad, steering wheel and shell cover.

Refer to Section ST (Page ST-3) for Removal.

3. Remove screws securing instrument garnish to instrument, and detach garnish.
4. Remove screws securing upper instrument to cowl top panel.
5. Remove screws securing instrument finisher to instrument, and detach finisher.

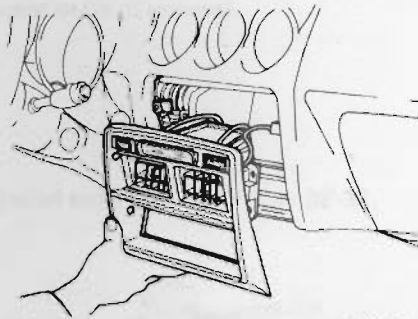

BF405A

Fig. BF-88 Removing instrument finisher

6. Remove floor console.
7. Remove screws securing air control finisher to instrument.
8. Remove screws securing instru-

- ment to the upper side of floor tunnel.
9. Remove screws securing side ventilator control bracket in place.
10. Remove screws from each side of lower instrument.
11. Disconnect instrument harnesses at:
 - (1) Junction block
 - (2) Combination switch
 - (3) Ignition switch
 - (4) Stop lamp switch
 - (5) Flasher units (for turn signal and hazard)
 - (6) Door switch
12. Disconnect cable from speedometer.
13. Install instrument panel in the reverse order of removal.

INSTRUMENT PANEL UNDER COVER

1. Remove two screws securing under cover to instrument panel.
2. Install instrument panel under cover in the reverse order of removal.

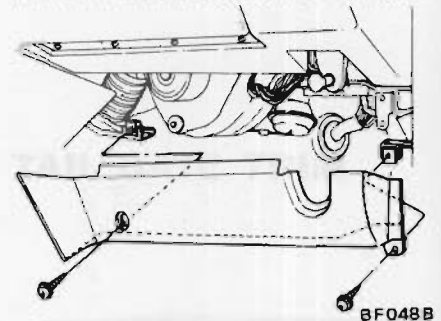

BF048B

Fig. BF-89 Instrument panel under cover

BODY SEALING

DESCRIPTION

Sealer is applied to the individual panel joints to secure body sealing.

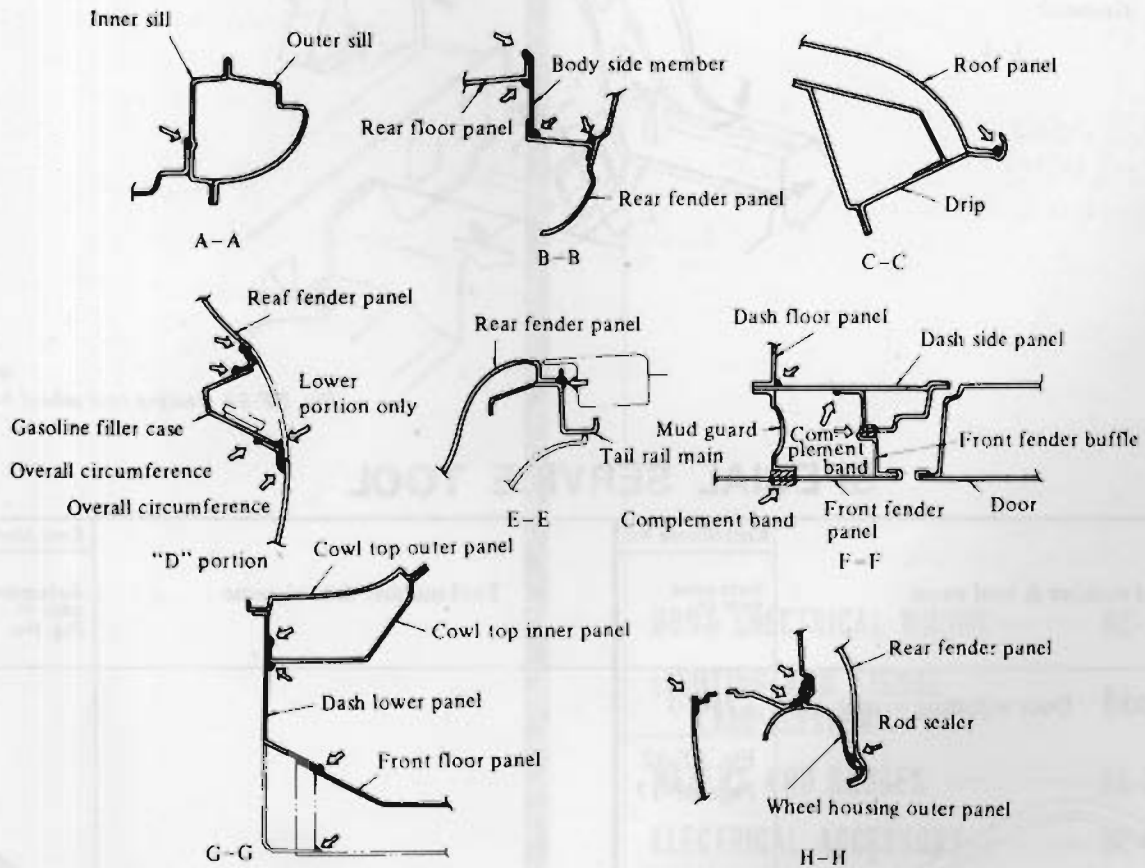
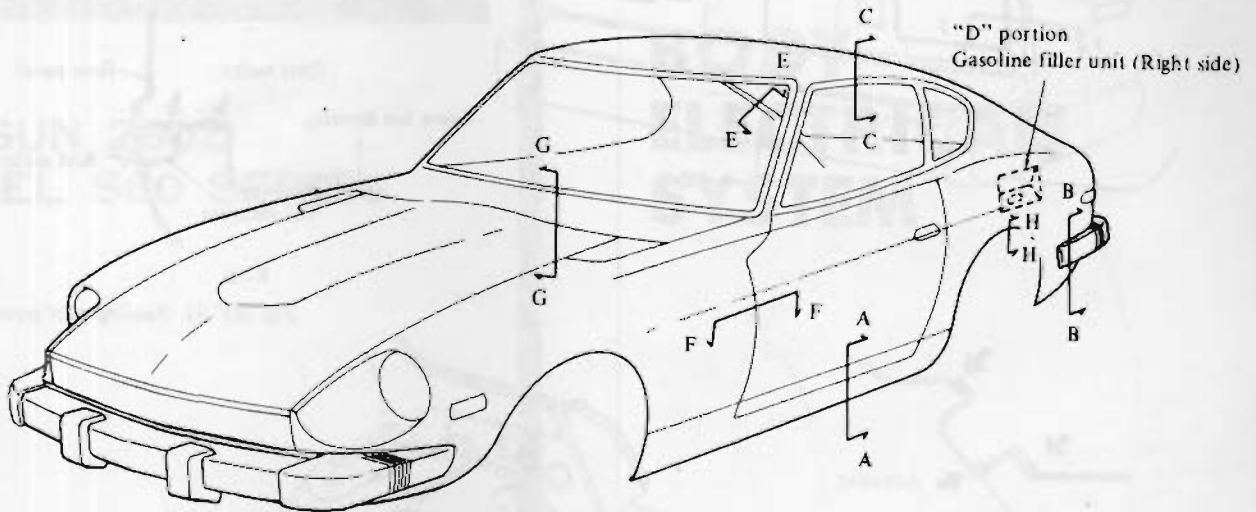

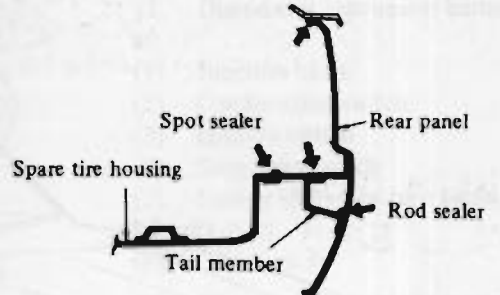
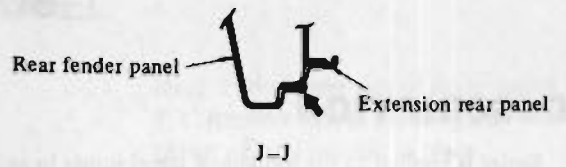
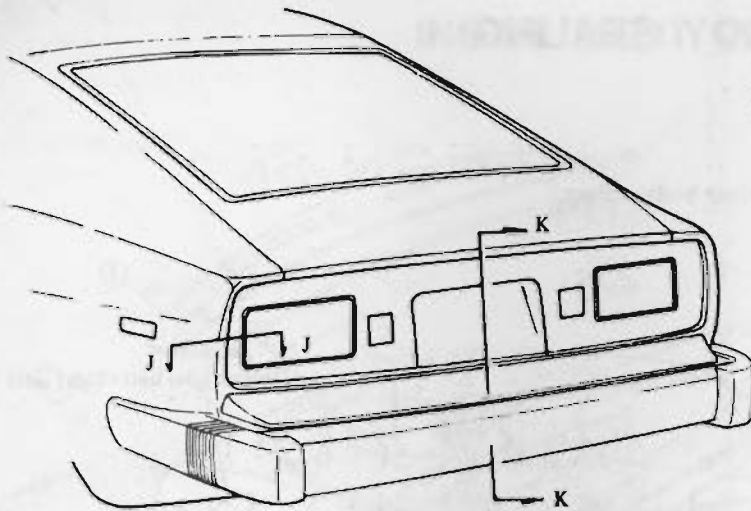

K-K

BF022B

Fig. BF-91 Sealing rear panel joint

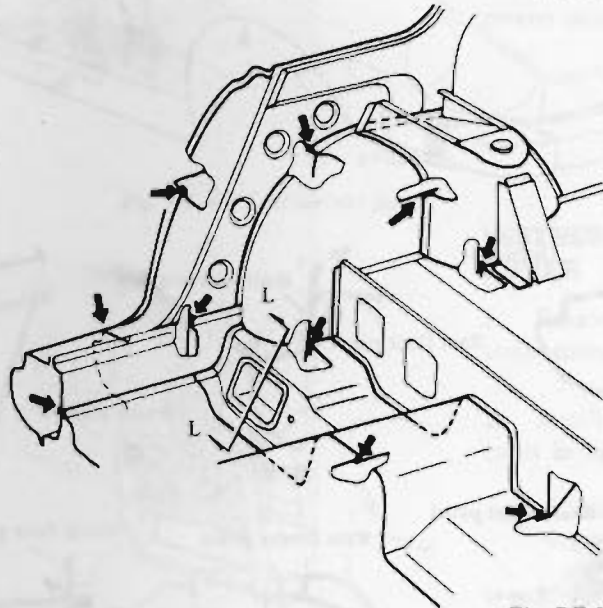
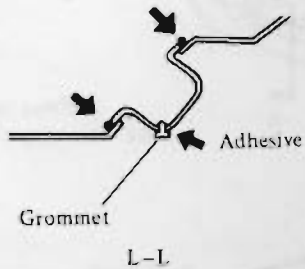

BF408A

Fig. BF-92 Sealing rear wheel housing

SPECIAL SERVICE TOOL

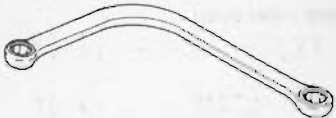
Tool number & tool name	Kent-Moore No.	Tool number & tool name	Kent-Moore No.
	Reference page or Fig. No.		Reference page or Fig. No.
ST08720000 Door adjusting wrench	J 25610		
	Fig. BF-42 Page BF-17		