

SERVICE MANUAL

DATSUN 260Z
MODEL S30 SERIES

SECTION ER

ENGINE REMOVAL AND INSTALLATION

ER

ENGINE REMOVAL AND
INSTALLATIONER- 2

SERVICE DATA AND
SPECIFICATIONSER- 5



NISSAN MOTOR CO., LTD.
TOKYO, JAPAN

ENGINE REMOVAL AND INSTALLATION

CONTENTS

REMOVAL	ER-2	ENGINE MOUNTING INSULATORS	ER-4
INSTALLATION	ER-4	FRONT INSULATOR	ER-4
		REAR INSULATOR	ER-4

REMOVAL

It is much easier to remove engine and transmission as a single unit than to remove alone. After removal, engine can be separated from the transmission assembly.

Notes:

- Be sure to hoist engine and jack up transmission in a safe manner.
- Fender covers should be used to prevent damaging car body.

- Disconnect battery ground cable.
- Remove hood as follows:
 - Mark hood hinge locations on hood to facilitate proper reinstallation.
 - Support hood by hand and remove bolts securing it to hood hinge, taking care not to let hood slip when bolts are removed.
 - Remove hood from hood hinge with the help of an assistant. See Figure ER-1.



Fig. ER-1 Removing hood

- Remove air cleaner.
- Drain radiator coolant and engine oil.
- Disconnect upper and lower hoses from radiator.
- Remove bolts securing radiator to body and detach radiator, and shroud (if so equipped).

Notes:

On automatic transmission models:

- Remove splash board.

- Disconnect oil cooler hoses from oil cooler installed at the lower end of radiator.

- Disconnect vacuum hose.

- Disconnect accelerator linkage. See Figure ER-2.



Fig. ER-2 Disconnecting accelerator linkage

- Disconnecting following cables, wires and hoses:

- Engine ground cable at the engine connection end
- Wires to starter motor
- High tension cable (between ignition coil and distributor)
- Wire to distributor at the connection
- Wire to thermal transmitter
- Wire for water temperature switch at the connector
- Wires to alternator
- Choke wires
- Wire for throttle opener solenoid (Manual transmission models) See Figure ER-3.

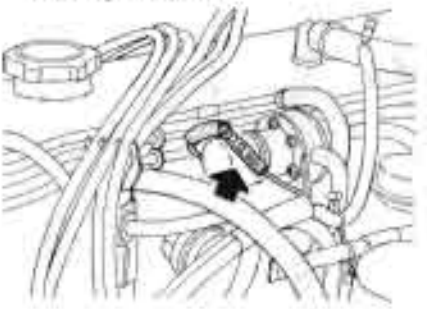

Fig. ER-3 Disconnecting wire for throttle opener solenoid

- Wire for choke heater
- Wire for E.G.R. solenoid valve See Figure ER-4.



Fig. ER-4 Disconnecting wire for E.G.R. solenoid valve

- Wire for vacuum cutting solenoid (Manual transmission models)
- Canister purge hose (1) and vacuum signal hose (2). See Figure ER-5.

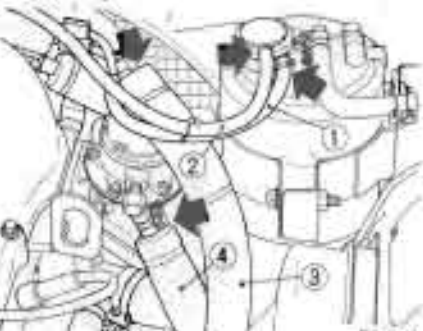

Fig. ER-5 Disconnecting hoses from canister, and fuel hoses

- Fuel return hose (3) and fuel charge hose (4) See Figure ER-5.
- Heater inlet and outlet hoses
- Vacuum hose to Master-Vac at intake manifold
- Wires for back-up lamp switch, neutral switch and top detecting switch

Note:

On automatic transmission models:

Disconnect wire at connections of inhibitor switch and downshift solenoid at wire connector.

9. Remove clutch operating cylinder (Manual transmission models).

See Figure ER-6

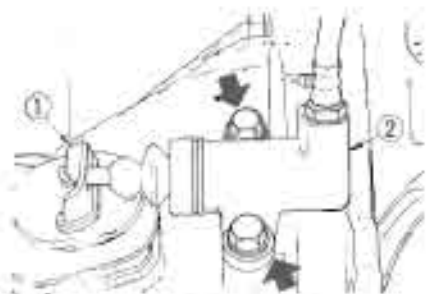

1. Withdrawal lever
2. Clutch operating cylinder

Tightening torque:
2.5 to 3.0 kg-m (18 to 22 ft-lb)

ER191

Fig. ER-6 Removing clutch operating cylinder

10. Disconnect speedometer cable from rear extension housing.

11. Remove transmission control linkage.

(1) For cars equipped with manual transmission, remove gear shift control lever.

(2) For cars equipped with automatic transmission, disconnect selector range lever.

12. Disconnect exhaust front tube from exhaust manifold, See Figure ER-7.

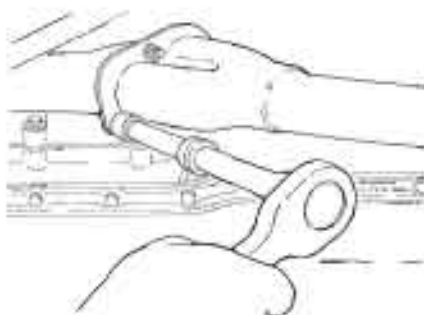

Tightening torque:
2.0 to 2.5 kg-m (14 to 18 ft-lb)

ER192

Fig. ER-7 Disconnecting exhaust front tube

12. Remove propeller shaft.

Remove four bolts on the differential carrier side, withdraw propeller shaft, and seal end of rear extension housing to prevent oil leakage. See Figure ER-8.



Tightening torque:
2.5 to 3.2 kg-m (18 to 23 ft-lb)

ER193

Fig. ER-8 Removing propeller shaft



Manual transmission



Automatic transmission

Tightening torque:

(A) 3.2 to 4.3 kg-m
(23 to 31 ft-lb)

ER194

Fig. ER-9 Rear engine mounting member specifications

Note: Put match marks on both shaft and companion flange so that shaft can be reinstalled in original position.

14. Support transmission with jack.

15. Remove bolts securing rear engine mounting member to the body.

Note: Different members are used on manual transmission models and automatic transmission ones. See Figure ER-9.

16. Connect suitable wire or chain to engine slingers and raise engine to take weight off front mounting insulators.

17. Remove bolts securing engine support to front mounting insulators.

18. Raise engine and transmission, and remove from car as a single unit. See Figure ER-10.

Note: In this operation, care should always be taken to prevent the unit from hitting any adjacent parts.

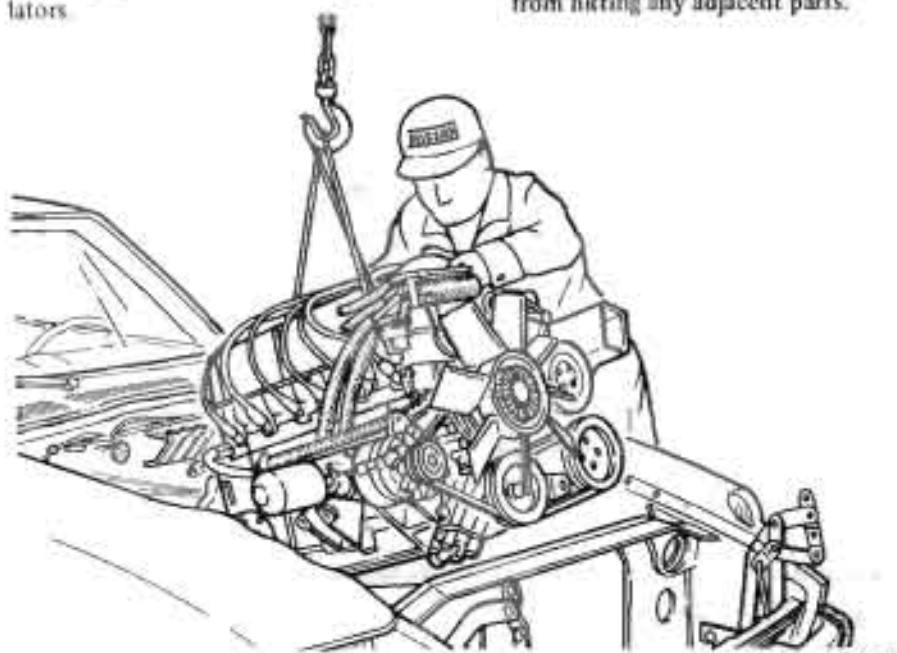

ER195

Fig. ER-10 Removing engine

INSTALLATION

Install in the reverse order of removal, observing the following:

1. When installing, first secure rear engine mounting member to body.
2. Refer to applicable section when installing and adjusting any parts.
3. When installing hood following engine installation, be sure that it is properly centered and that hood lock operates securely. Refer to Section BF for Adjustment.

ENGINE MOUNTING INSULATORS

Three insulators are used to mount the engine and transmission; two located at left and right front ends of the cylinder block and one at the transmission rear extension housing.

Replace insulator if it shows signs of separation or deterioration.

Be sure to keep insulator free from oil or grease.

FRONT INSULATOR

Left and right front insulators are identical, and are interchangeable. See Figure ER-11.

Removal

1. Suspend engine with wire or chain.
2. Loosen front engine mounting insulator upper nuts (both sides).
3. Make sure that wire or chain used to suspend engine is positioned properly so that no load is applied to insulators, and remove nuts completely.
4. Lift up engine, and separate insulators from engine mounting brackets.

Inspection

If there is damage, deterioration or separation of bonded surface, replace.

Installation

Install front insulators in reverse sequence of removal, noting the following:

1. Both the left and right front insulators are used commonly. However, when installing them, pay attention to their upper and lower directions. See Figure ER-11.

2. The shape of the right side bracket differs from that of the left side bracket. Tighten the bolts and nuts correctly and securely. See Figure ER-11.

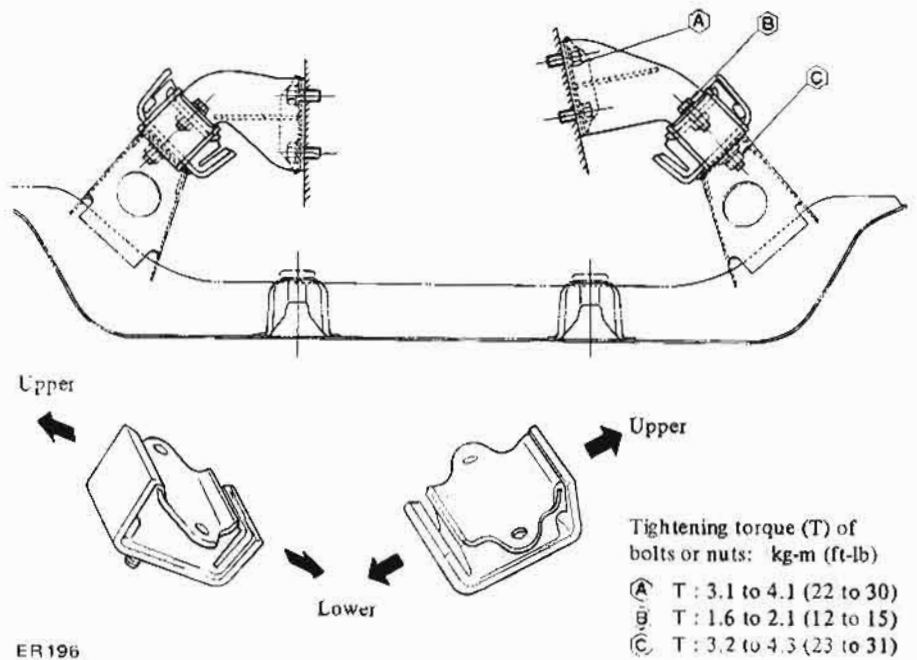

Fig. ER-11 Sectional view of front engine mounting, and front insulator

REAR INSULATOR

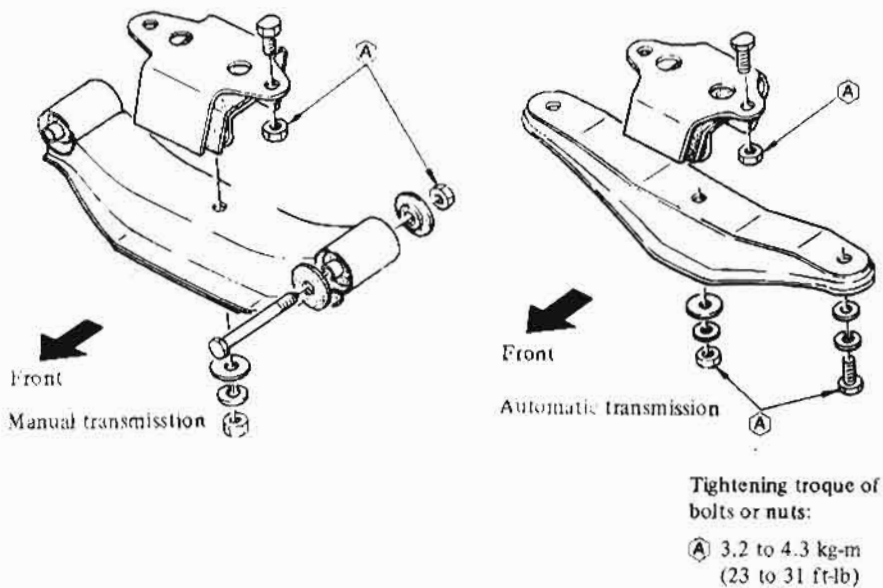

Fig. ER-12 Rear engine mounting and rear insulator

Removal

1. Support transmission with a jack or suitable stand so that engine does not drop down.

2. Remove rear engine mounting member installation bolts.

3. Engine mounting member is provided with openings for removing and installing operations. Remove nuts and separate insulator from transmission.
4. Remove bolts, and separate insulator from engine mounting member.

Inspection

If there is damage, deterioration or separation of bounded surface, replace.

Installation

Install rear engine mounting mem-

ber and insulator in reverse sequence of removal, noting the following:

1. Tighten nuts and bolts correctly and securely. As for tightening torque, see Figure ER-12.
2. Carefully arrange the front and rear directions of rear engine mounting member and insulator when installing. See Figure ER-12.

SERVICE DATA AND SPECIFICATIONS

TIGHTENING TORQUE

	kg-m (ft-lb)
Rear engine mounting to body	3.2 to 4.3 (23 to 31)
Rear insulator to rear engine mounting member	3.2 to 4.3 (23 to 31)
Rear insulator to transmission	3.2 to 4.3 (23 to 31)
Front engine mounting bracket to engine	3.1 to 4.1 (22 to 30)
Front insulator to engine mounting bracket	1.6 to 2.1 (12 to 15)
Front insulator to suspension member	3.2 to 4.3 (23 to 31)
Clutch operating cylinder to clutch housing	2.5 to 3.0 (18 to 22)
Front tube to exhaust manifold	2.0 to 2.5 (14 to 18)
Propeller shaft to companion flange	2.5 to 3.2 (18 to 23)