

SERVICE MANUAL

DATSUN 240Z
MODEL S30 SERIES



NISSAN

NISSAN MOTOR CO., LTD.
TOKYO, JAPAN

SECTION AT

AUTOMATIC TRANSMISSION

AT

DESCRIPTION	AT- 2
HYDRAULIC CONTROL SYSTEM	AT- 4
REMOVAL AND INSTALLATION	AT-33
MAJOR REPAIR OPERATION	AT-37
TROUBLE DIAGNOSES AND ADJUSTMENT	AT-49
SERVICE DATA AND SPECIFICATIONS	AT-60

CHASSIS

DESCRIPTION

The model 3N71B automatic transmission is a fully automatic unit consisting primarily of 3-element hydraulic torque converter and two planetary gear sets. Two multiple-disc clutches, a multiple-disc brake, a band brake and a one way sprag clutch provide the friction elements required to obtain the desired function of the two planetary gear sets.

The two planetary gear sets give three forward ratios and one reverse. Changing of the gear ratios is fully automatic in relation to vehicle speed and engine torque input. Vehicle speed and engine manifold vacuum signals are constantly fed to the transmission to provide the proper gear ratio for maximum efficiency and performance at all throttle openings.

The Model 3N71B has six selector positions: P, R, N, D, 2, 1.

"P" – Park position positively locks the out put shaft to the transmission case by means of a locking pawl to prevent the vehicle from rolling either direction.

This position should be selected whenever the driver leaves the vehicle.

The engine may be started in Park position.

"R" – Reverse range enables the vehicle to be operated in a reverse direction.

"N" – Neutral position enables the engine to be started and run without driving the vehicle.

"D" – Drive range is used for all normal driving conditions. Drive range has three gear ratios, from the starting ratio to direct drive.

"2" – "2" range provides performance for driving on slippery surfaces. "2" range can also be used for engine braking.

"2" range can be selected at any vehicle speed, and prevents the transmission from shifting out of second gear.

"1" – "1" range can be selected at any vehicle speed and the transmission will shift to second gear and remain in second until vehicle speed is reduced to approximately 40 to 50 km/h (25 to 31 MPH).

"L" range position prevents the transmission from shifting out of low gear. This is particularly beneficial for maintaining maximum engine braking, when continuous low gear operation is desirable.

The torque converter assembly is of welded construction and can not be disassemble for service.

Fluid recommendation

Use automatic transmission fluid having "DEXRON" identifications only in the 3N71B automatic transmission.

Identification number

Stamped position:

The plate attached to the right hand side of transmission case as shown in Figure AT-1.

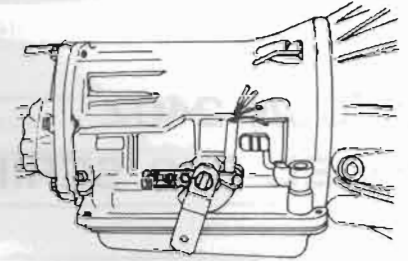

AT057

Fig. AT-1 Identification number

Identification of number arrangements;

See below.

Model code

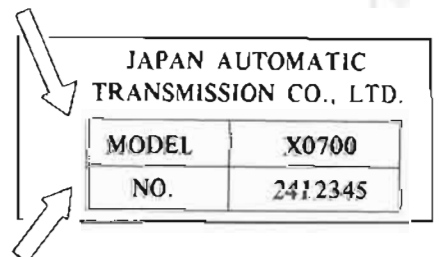

Unit number

Number designation

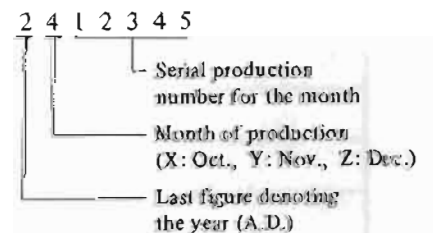

AUTOMATIC TRANSMISSION

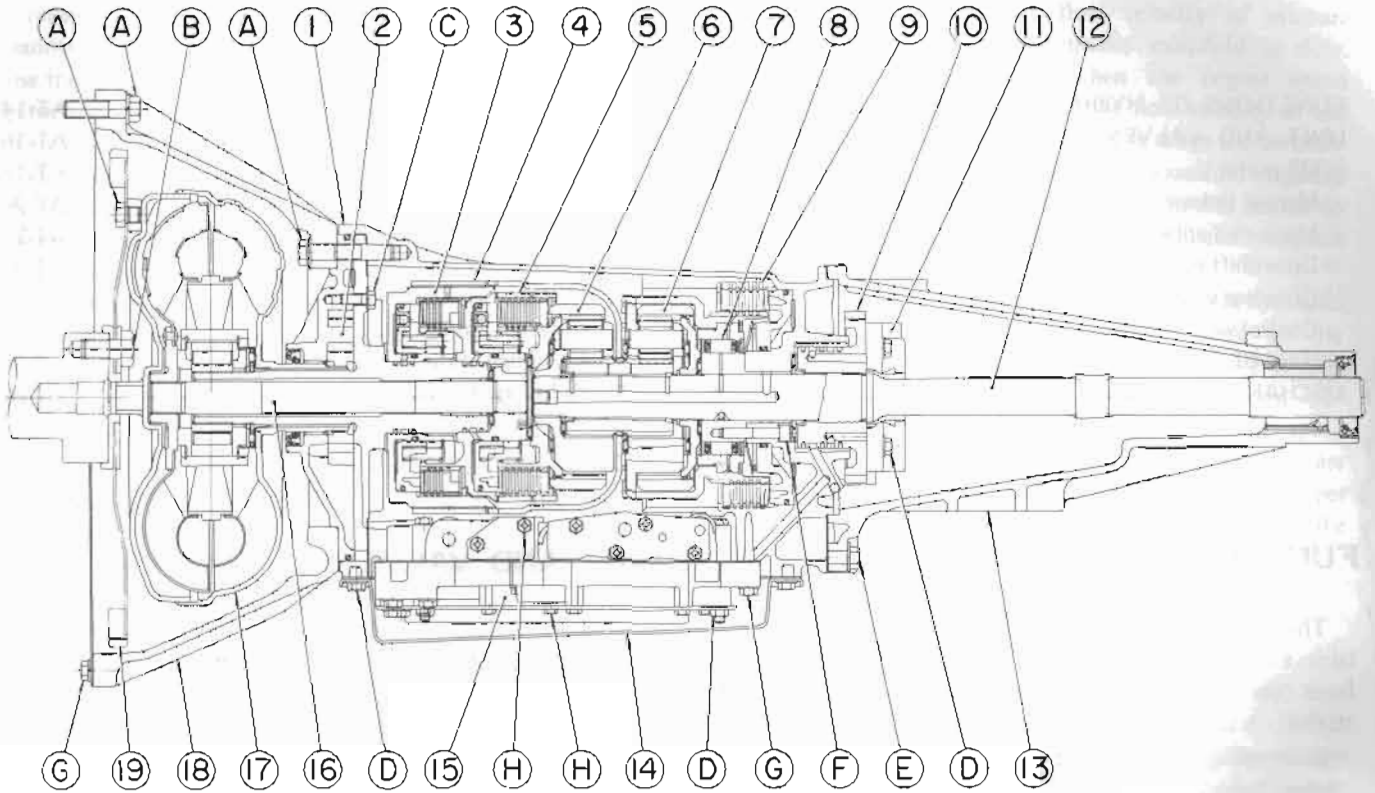

AT267

- 1 Transmission case
- 2 Oil pump
- 3 Front clutch
- 4 Band brake
- 5 Rear clutch
- 6 Front planetary gear
- 7 Rear planetary gear
- 8 One way clutch
- 9 Low & Reverse brake
- 10 Oil distributor

- 11 Governor
- 12 Output shaft
- 13 Rear extension
- 14 Oil pan
- 15 Control valve
- 16 Input shaft
- 17 Torque converter
- 18 Converter housing
- 19 Drive plate

Tightening torque (T) of bolts and nuts kg-m (ft-lb)

- Ⓐ T = 4 to 5 (29 to 36)
- Ⓑ T = 14 to 16 (101 to 116)
- Ⓒ T = 0.6 to 0.8 (4.3 to 5.8)
- Ⓓ T = 0.5 to 0.7 (3.6 to 5.1)
- Ⓔ T = 2.0 to 2.5 (14 to 18)
- Ⓕ T = 1.3 to 1.8 (9.4 to 13)
- Ⓖ T = 0.55 to 0.75 (4.0 to 5.4)
- Ⓗ T = 0.25 to 0.35 (1.9 to 2.5)

Fig. AT-2 Cross-sectional view of 3N71B automatic transmission

CHASSIS

HYDRAULIC CONTROL SYSTEM

CONTENTS

FUNCTIONS OF HYDRAULIC CONTROL

UNIT AND VALVES	AT- 4
Oil pump	AT- 4
Manual linkage	AT- 5
Vacuum diaphragm	AT- 5
Downshift solenoid	AT- 5
Governor valve	AT- 5
Control valve assembly	AT- 7
HYDRAULIC SYSTEM AND MECHANICAL OPERATION	AT-13

"P" range (Park)	AT-14
"R" range (Reverse)	AT-16
"N" range (Neutral)	AT-18
"D ₁ " range (Low gear)	AT-20
"D ₂ " range (2nd gear)	AT-22
"D ₃ " range (Top gear)	AT-24
"D" range kick-down	AT-26
"2" range (2nd gear)	AT-28
"1 ₁ " range (Low gear)	AT-30
"1 ₂ " range (2nd gear)	AT-32

FUNCTIONS OF HYDRAULIC CONTROL UNIT AND VALVES

The hydraulic control system contains a oil pump for packing up oil from the oil pan through the oil strainer. A shift control is provided by two centrifugally operated hydraulic

governors on the output shaft, vacuum control diaphragm and downshift solenoid. These parts work in conjunction with valves in the valve body

assembly located in the base of the transmission. The valves regulate oil pressure and direct it to appropriate transmission components.

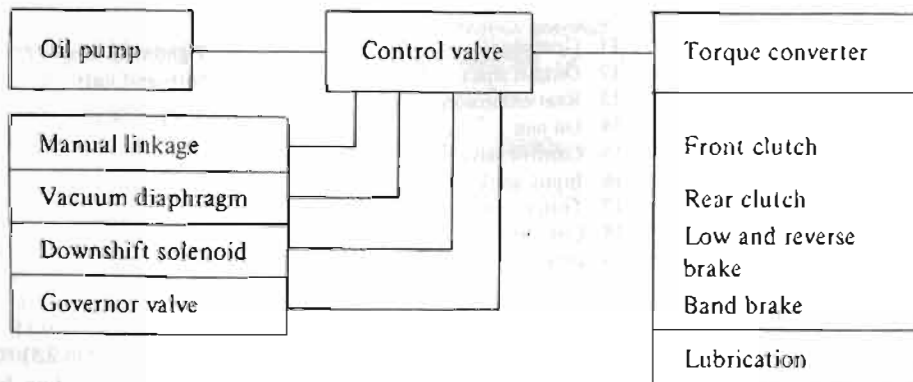

Oil pump

The oil pump is the source of control medium (in other words, oil) for the control system.

The oil pump is of an internal, involute gear type. The drive sleeve is a part of the torque converter pump

impeller and serves to drive the pump inner gear with the drive sleeve directly coupled with the engine operation.

The oil flows through the following route:

Oil pan – Oil strainer (bottom of the control valve) – Control valve lower

body suction port – Transmission case suction port – Pump housing suction port – Pump gear space – Pump housing delivery port – Transmission case delivery port – Lower body delivery port – Control valve line pressure circuit.

AUTOMATIC TRANSMISSION

Manual linkage

The hand lever motion (The hand lever is located in the driver's compartment.) mechanically transmitted from the remote control linkage is further transmitted to the inner manual lever in the transmission case from the range selector lever in the right center portion of the transmission case through the manual shaft. The inner manual lever is thereby turned.

A pin installed on the bottom of the inner manual lever slides the manual valve spool of the control valve, and thus, the spool is appropriately positioned opposing to each select position.

The parking rod pin is held in the groove on the top of the inner manual plate. The parking rod pin operates the rod at "P" range, and operates the mechanical lock system.

Moreover, the above described manual shaft is equipped with an inhibitor switch. A rotor inside the inhibitor switch rotates in response to each range. When the range is selected at "P" or "N," the rotor closes the starter magnet circuit so that the engine can be started. When the range is selected at "R," the rotor closes the back-up lamp circuit, and the back-up lamp lights.

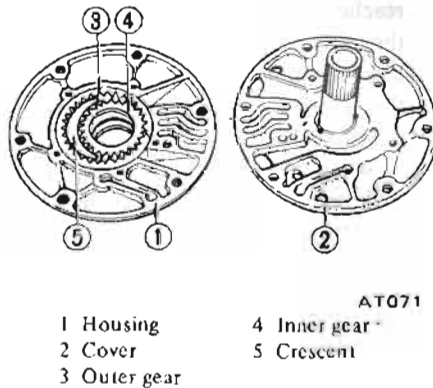

Fig. AT-3 Oil pump

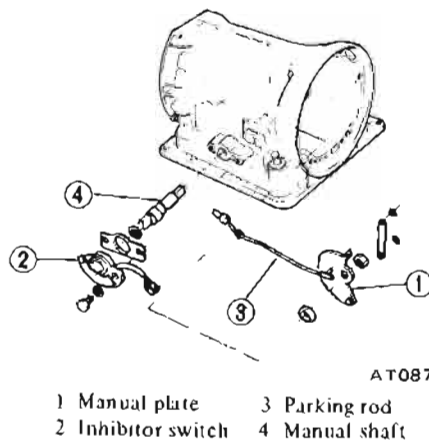

Fig. AT-4 Manual linkage

Vacuum diaphragm

The vacuum diaphragm is installed on the left center portion of the transmission case. The internal construction of the vacuum diaphragm is as follows. A rubber diaphragm forms a partition in the center. The engine intake manifold negative pressure led through vacuum tube and spring force are applied to the front surface of the rubber diaphragm, and atmospheric pressure is applied to the back surface. A difference between pressure applied to the front and back surfaces becomes a vacuum reaction, and thus, the throttle valve of the control valve inside the transmission case is operated.

When accelerator pedal is fully depressed and the carburetor is fully opened but the engine speed is not

sufficiently increased, the manifold negative pressure lowers (becomes similar to the atmospheric pressure) and the vacuum reaction increases since the flow velocity of mixture inside the intake manifold is slow. Contrarily, when the engine speed increases and the flow velocity of the mixture increases or when the carburetor is closed, the manifold negative pressure increases (becomes similar to vacuum) and the vacuum reaction reduces.

Thus, a signal to generate hydraulic pressure completely suited to the engine loading at the control valve is transmitted from the vacuum diaphragm, and most suitable speed change timing and line pressure are obtained so that the most proper torque capacity is obtained against the transmitting torque.

Downshift solenoid

The downshift solenoid is of a magnetic type installed on the left rear portion of the transmission case. When a driver requires accelerating power and depresses the accelerator pedal down to the stopper, a kick-down switch located in the middle of the accelerator link is depressed by a push rod, the kick-down switch closes, current flows to the solenoid, the solenoid push rod is depressed, the downshift valve of the control valve inside the transmission case is depressed, and the speed is changed forcibly from "3rd" to "2nd" within a certain vehicle speed limit.

Note: As the kick-down switch closes when the accelerator pedal is depressed from 7/8 to 15/16 of the whole stroke, the accelerator pedal should be correctly adjusted and fixed so as to afford complete stroke.

The arrangement of the switch differs according the models of vehicle.

Governor valve

The primary and secondary governor valves are installed separately on the back of the oil distributor on the

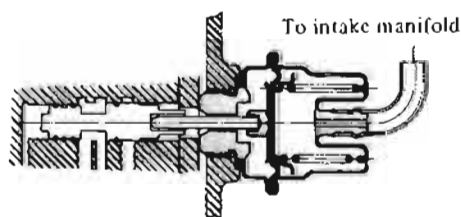

Fig. AT-5 Vacuum diaphragm

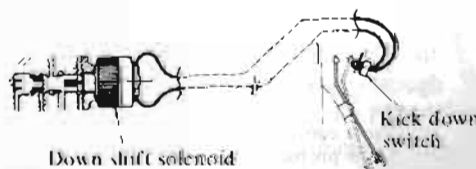

Fig. AT-6 Downshift solenoid

transmission output shaft. They operate in the same speed as that of the output shaft. (In other words, they operate at a speed in proportion to the vehicle speed.) To those valves, the line pressure is applied as the input from the control valve through the transmission case, rear flange and oil distributor. The governor pressure [in proportion to the output shaft speed (vehicle speed)] is led to the shift valve of the control valve through inverse route as the output, and thus, the speed change and the line pressure are controlled.

Operation of secondary governor valve

The secondary valve is a control valve which receives line pressure (1) and controls the governor pressure.

When the manual valve is selected at "D," "2," or "1" range, line pressure is applied to the ring shape area of this valve from circuit (1), and this valve is depressed toward the center side. Movement of this valve to a certain position closes the circuit from (1) to (15) simultaneously while making a space from the (15) to the center drain port, and pressure in the circuit (15) is lowered.

When the vehicle is stopped and the centrifugal force of this valve is zero, the valve is balanced. In this, a governor pressure which is balanced with the spring force occurs on the (15).

When the vehicle is started and the centrifugal force increases, this valve slightly moves to the outside, and when the space from (1) to (15) increases, space from the (15) to the drain port reduces simultaneously. As the result, governor pressure of the (15) increases, and the governor pressure is balanced with the sum of centrifugal force and the spring force. The governor pressure thus changes in response to the vehicle speed change (centrifugal force).

Operation of primary governor valve

The valve is an ON-OFF valve which closes the governor pressure (15) regulated by the secondary gover-

nor valve when the vehicle speed reaches the minimum speed, and when the vehicle speed exceeds a certain level open the governor and forwards the governor pressure (15) to the control valve.

When the vehicle is stopped, the governor pressure is zero. However, when the vehicle is running slowly, this valve is depressed to the center side and the groove to the (15) is closed since the governor pressure applied to the ring shape area is higher than the centrifugal force of this valve. When the governor speed exceeds certain revolution, the governor pressure in the circuit (15) also increases. However, as the centrifugal force increases and exceeds the governor pressure, this valve moves toward the outside, and the governor pressure is transmitted to the circuit (15).

Two different valves are employed in the governor so that it will independently control the speed at high speed and at low speed. That is, within the low speed range, the governor pressure is not generated owing to the primary valve; whereas at the high speed range above the break point, a governor pressure regulated by the secondary valve is introduced.

* The break point is the point at which the function of one of the governors is transferred to the other when the speed changes from the low-speed range to the high-speed range.

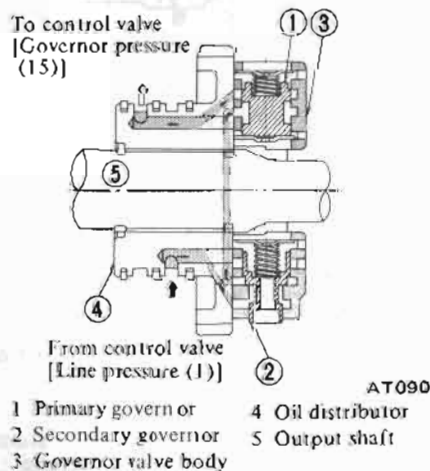

1 Primary governor valve
2 Secondary governor valve body
3 Governor valve body
4 Oil distributor
5 Output shaft

Fig. AT-7 Cross-sectional view of governor

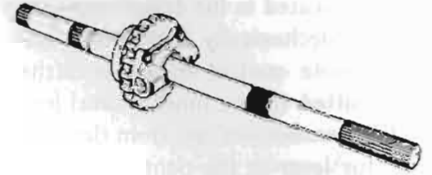
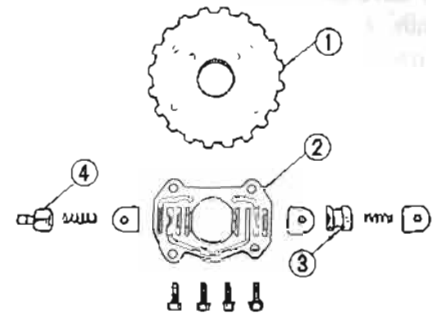

Fig. AT-8 Output shaft with oil distributor and governor



1 Oil distributor
2 Governor valve body
3 Primary governor valve
4 Secondary governor valve

Fig. AT-9 Exploded view of governor

AUTOMATIC TRANSMISSION

Control valve assembly

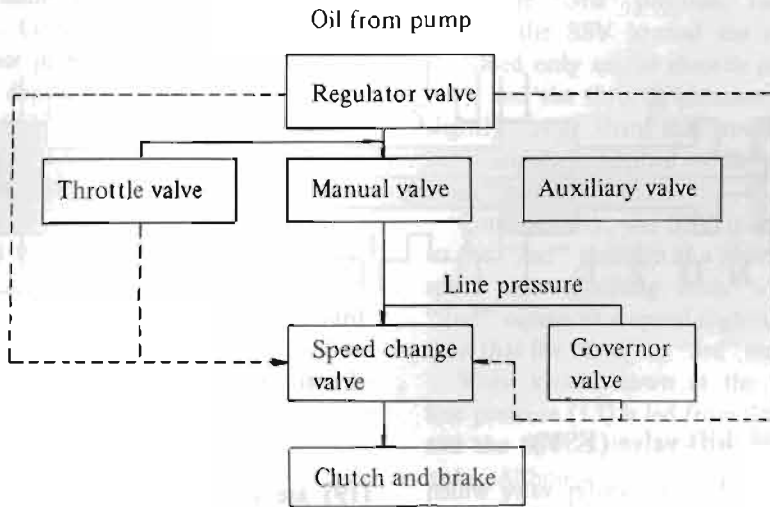

Flow chart of control valve system

The control valve assembly receives oil from the pump and the individual signals from the vacuum diaphragm, and transmits the individual line pressures to the transmission friction element, torque converter circuit, and lubricating system circuit as the outputs. To be more specifically, the oil from the oil pump is regulated by the regulator valve and line pressures build up. The line pressures are fed out from the control valve assembly as they are through various direction changeover valves (including ON-OFF valve) and regulator valves, newly reformed to a throttle system oil pressure and operates other valves, or finally, the line pressure are transmitted to the required clutch or brake servo piston unit in response to the individual running conditions after receiving signals from the previously described vacuum diaphragm, downshift solenoid, governor valve, and/or manual linkage.

The control valve assembly consists of the following valves:

1. Pressure regulator valve
2. Manual valve
3. 1st-2nd shift valve

4. 2nd-3rd shift valve
5. Pressure modifier valve
6. Vacuum throttle valve
7. Throttle back-up valve
8. Solenoid downshift valve
9. Second lock valve
10. 2nd-3rd timing valve

Pressure regulator valve (PRV)

The pressure regulator valve receives valve spring force, force from plug created by the throttle pressure (16) and line pressure (7), and force of the throttle pressure (18). With the mutual operations of those forces, the PRV regulates the line pressure (7) to the most suitable pressures at the individual driving conditions.

The oil from the oil pump is applied to the ring-shaped area through orifice (20). As the result, the PRV is depressed downward, and moves from port (7) up to such extent that the space to the subsequent drain port (marked with "x" in Figure AT-10) opens slightly. Thus, the line pressure (7) is balanced with the spring force,

and the PRV is thereby balanced. In this, the space from the port (7) to the subsequent converter oil pressure (14) circuit has also been opened. As the result, the converter is filled with the pressurized oil in the circuit (14), and the oil is further used for the lubrication of the rear unit. Moreover, a part of the oil is branched and used for the lubrication of front unit for the front and rear clutches.

When the accelerator pedal is depressed, the throttle pressure (16) increases as described in the preceding paragraph, oil pressure is applied to the plug through orifice (21), and the pressure is added to the spring force. As the result, the PRV is contrarily depressed upward, space to the drain port is reduced, and the line pressure (7) increases.

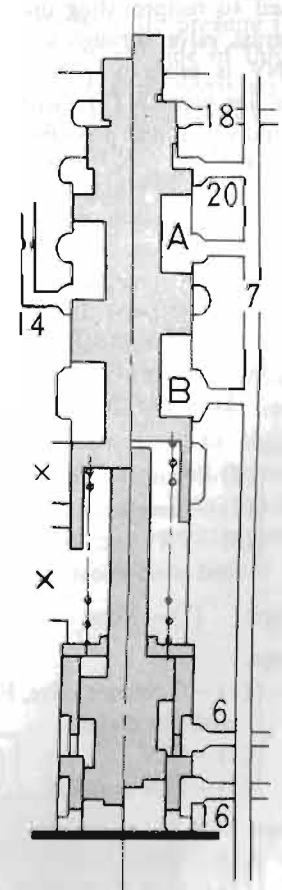

AT095

Fig. AT-10 Pressure regulator valve

When the range is selected at "R" (Reverse), the line pressure (6) is applied to the plug in the manner identical to the throttle pressure (16) and is added to the spring force. Consequently, the line pressure (7) further increases.

When the vehicle speed increases and the governor pressure rises, the throttle pressure (18) is applied to the port on the top of the PRV, and pressure is applied contrarily against the spring force. As the result, the line pressure (7) lowers. Moreover, at the individual conditions, the line pressure (7) is equal to the line pressure (6) and the throttle pressure (16) is equal to (18).

Manual valve (MNV)

The manual lever turning motion is converted to reciprocating motion of the manual valve through a pin, and the MNV is properly positioned so that the line pressure (7) is distributed to the individual line pressure circuits at each "P," "R," "N," "D," "2" or "1" range as shown below.

"P" range:

(7) - { (4) - SDV and TBV
(5) - FSV (12) - TBV and Low & reverse brake

"R" range:

(7) - { (4) - Same as above
(5) - Same as above
(6) - PRV and SSV - (F.C.) and band release

"N" range: (7) - None

"D" range:

(7) - { (1) - Governor valve, FSV, and rear clutch
(2) - SLV
(3) - SLV and SSV

"2" range:

(7) - { (1) - Same as above
(2) - SLV - (9) Band applied
(4) - SDV and TBV

"1" range:

(7) - { (1) - Same as above
(4) - Same as above
(5) - FSV

Moreover, (1), (2), (3), (4), (5), and (6) are always drained at a position where the line pressure is not distributed from (7).

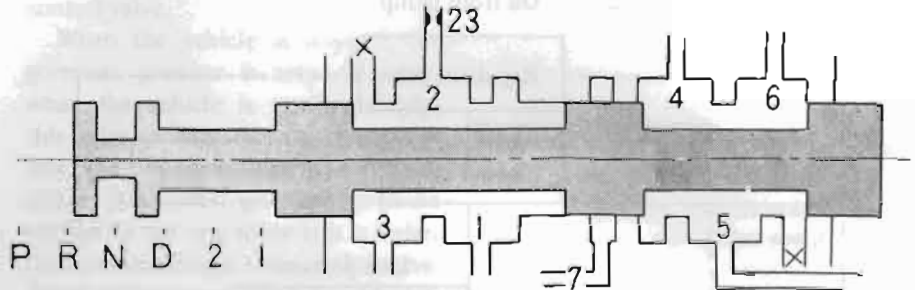

AT096

Fig. AT-11 Manual valve

1st-2nd shift valve (FSV)

The FSV is a transfer valve which shifts speed from low to second. When the vehicle is stopped, the FSV is depressed to the right side by the force of a spring located in the left side, and thus, the FSV is in the "Low" position.

When the vehicle speed increases, the governor pressure (15) is applied to the right side of the FSV, and the FSV is depressed toward the left. Contrarily, the line pressure (1) and throttle pressure (19) depress the FSV toward the right together with the spring force, and thus, oppose to the governor pressure (15).

When the vehicle speed exceeds a certain level, the governor pressure (15) exceeds the sum of the throttle pressure and the spring force, and the FSV is depressed toward the left.

When the FSV is depressed and reaches a certain position, the line pressure (1) and the throttle pressure

(19) are closed, only the spring depresses the FSV toward the right, and the FSV is depressed to the end for a moment. As the result, the line pressure (1) is forwarded to (8), the band servo is engaged through the SLV, and thus, the speed is shifted to "2nd." With the accelerator pedal depressed, the FSV is remained in the "Low" position unless the governor pressure (15) increases to a high level corresponding to the line pressure (1) and the throttle pressure (19) since the line pressure (1) and the throttle pressure (19) increase when the accelerator pedal is depressed.

Contrarily, when the vehicle speed lowers, the governor pressure (15) reduces. However, the speed is not shifted to "Low" unless the governor pressure (15) becomes zero since the force to depress the FSV toward the right is remained only on the spring.

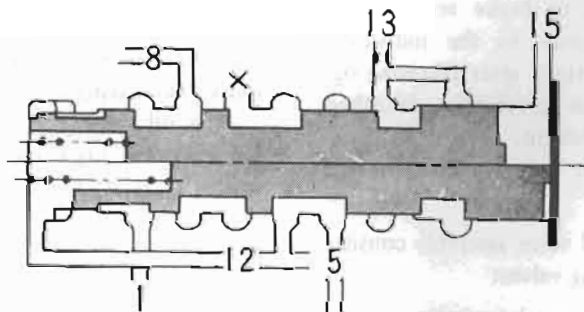

AT097

Fig. AT-12 "1st-2nd" shift valve

AUTOMATIC TRANSMISSION

"Low" in the range "1" is led to the low and reverse clutch from the line pressure (5) through the line pressure (12), and at the same time, the same is led to the left end spring unit. Consequently, although the governor pressure increases, the valve is still depressed toward the right, and the SFV is fixed in the "Low" position. When kicked down at the "2nd" speed, the SDV operates, and the line pressure (13) depresses the FSV toward the right. Although the governor pressure (15) is considerably high, the valve is depressed completely toward the right, and the FSV is returned to the "Low" position. (This operation is called "Kick-down shift")

2nd-3rd shift valve (SSV)

The SSV is a transfer valve which shifts speed from "2nd" to "3rd." When the vehicle is stopped, the SSV is depressed toward the right by the spring, and is in the "2nd" position. It is provided, however, that the FSV decides the shifting either to "Low" or "2nd."

When the vehicle is running, the governor pressure (15) is applied to the right end surface, and the SSV is depressed toward the left. Contrarily, the spring force, line pressure (3), and throttle pressure (19) depress the SSV toward the right.

When the vehicle speed exceeds a certain level, the governor pressure exceeds the sum of the spring force, line pressure, and throttle pressure, the valve is depressed toward the left, and the line pressure (3) is closed. Consequently, the forces are rapidly unbalanced, the force to depress the SSV toward the right reduces, and thus, the SSV is depressed to the left end for a moment. With the SSV depressed toward the left end, the line pressure (3) is connected with the line pressure (10), the band servo is released, the front clutch is engaged, and speed is shifted to "3rd."

When the accelerator pedal is depressed, both the line pressure (3) and the throttle pressure (19) are high, and

therefore, the SSV is retained in "2nd" unless the governor pressure (15) exceeds the line pressure (3) and the throttle pressure (19).

In the "3rd" position, force to depress the SSV toward the right is remained only on the throttle pressure (16), and the throttle pressure (16) is slightly lower than that toward the right which is applied while shifting from "2nd" to "3rd."

Consequently, the SSV is returned to the "2nd" position at a slightly low speed side. (Shifting from "3rd" to "2nd" occurs at a speed slightly lower than that for "2nd" to "3rd" shifting.)

When kicked down at the "3rd," line pressure (13) is led from the SDV, and the SSV is depressed toward the right. Although the governor pressure is considerably high, the valve is depressed completely toward the right, and thus, the SSV is returned to "2nd" position. (This operation is called "Kick-down shift.")

When the shift lever is shifted to "2" or "1" range at the "3rd" speed, the line pressure (3) is drained at the MNV. Consequently, the front clutch operating and band servo releasing oils are drained. As the result, the transmission is shifted to the "2nd" or "low" speed although the SSV is in the "3rd" position.

When the speed is shifted to the "3rd," a one-way orifice (24) on the top of the SSV relieves oil transmitting velocity from the line pressure (3) to the line pressure (10), and reduces a shock generated from the shifting. Contrarily, when shifted from "3rd" to "2" or "1" range and the speed is shifted to the "2nd," spring of the

orifice (24) is depressed, the throttle becomes ineffective, the line pressure (10) is drained quickly, and thus, delay in the speed shifting is eliminated.

Throttle of the line pressure (6) relieves the oil transmitting velocity from the line pressure (6) to the line pressure (10) when the lever is shifted to the "R" range, and relieves drain velocity from the line pressure (10) to the line pressure (6) when shifting from "3rd" to "2nd" at the "D" range. Thus, the throttle of the line pressure (6) reduces a shock generated from the shifting.

A plug in the SSV left end readjusts the throttle pressure (16) which varies depending on the engine throttle condition, to a throttle pressure (19) suited to the speed change control. Moreover, the plug is a valve which applies line pressure (13), in lieu of the throttle pressure, to the SSV and the FSV when kick-down is performed.

When the throttle pressure (16) is applied to the left side of this plug, and the plug is depressed toward the right, a slight space is made from the throttle pressure (16) to (19). A throttle pressure (19) which is lower by the pressure loss equivalent to this space is generated, the pressure loss is added to the spring force, and thus, the plug is depressed back from the right to the left. When this pressure (19) increases excessively, the plug is further depressed toward the left, space from the throttle pressure (19) to the drain circuit (13) increases, and the throttle pressure (19) lowers. Thus, the plug is balanced, and the throttle pressure (19) is reduced in a certain value

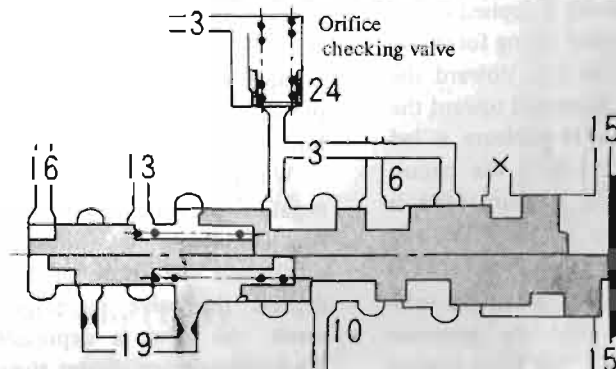

AT098

Fig. AT-13 "2nd-3rd" shift valve

against the throttle pressure (16).

When performing the kick-down, the SDV moves, a high line pressure is led to the circuit (19) from the line pressure circuit (13) (which had been drained), the plug is depressed toward the left, and the circuit (19) becomes equal to the line pressure (13). Thus, the kick-down is performed.

Pressure modifier valve (PMV)

In comparison with the operating pressure required in starting the vehicle, power transmitting capacity of the clutch (in other words, required operating pressure) may be lower when the vehicle is once started. When the line pressure is retained in a high level up to a high vehicle speed, a shock generated from the shifting increases, and the oil pump loss also increases. In order to prevent the above described defective occurrences, with the operation of the governor pressure (15), the throttle pressure must be changed over to reduce the line pressure. The PMV is used for this purpose.

When the governor pressure (15) which is applied to the right side of the PMV is low, the valve is depressed toward the right by the throttle pressure (16) (applied to the area difference of the valve) and the spring force, and the circuit from the circuit (16) to the circuit (18) is closed. However, when the vehicle speed increases and the governor pressure (15) exceeds a certain level, the governor pressure toward the left which is applied to the right side exceeds the spring force and the throttle pressure (16) toward the right, the valve is depressed toward the left, and the throttle pressure is led from the circuit (16) to the circuit (18). This throttle pressure (18) is applied to the top of the PRV, and pressure of the line pressure source (7) is reduced. Contrarily, when the vehicle speed lowers and the governor pressure (15) lowers, the force toward the right exceeds the governor pres-

sure, the valve is depressed back toward the right, the throttle pressure (18) is drained to the spring unit.

This valve is switched when the throttle pressure and the governor pressure are high or when the throttle pressure is low and the governor pressure is low.

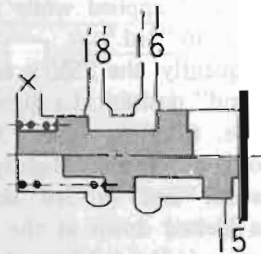

AT099

Fig. AT-14 Pressure modifier valve

Vacuum throttle valve (VTV)

The vacuum throttle valve is a regulator valve which uses the line pressure (7) for the pressure source and regulates the throttle pressure (16) which is proportioned to the force of the vacuum diaphragm. [The vacuum diaphragm varies depending on the engine throttle condition (negative pressure in the intake line)].

When the line pressure (7) is applied to the bottom through the valve hole and the valve is depressed upward, space from the line pressure (7) to the throttle pressure (16) is closed, and the space from the throttle pressure (16) to the drain circuit (17) is about to open. In this, the throttle pressure (16) becomes lower than the line pressure (7) by the pressure equivalent to the pressure loss of the space, and the force to depress through the rod of the vacuum diaphragm is balanced with the throttle pressure (16) applied upward to the bottom.

When the engine torque is high, the negative pressure in the intake line rises (similar to the atmospheric pressure), and the force of the rod to depress the valve increases. As the result, the valve is depressed downward, the space from the throttle pressure (16) to the drain (17) re-

duces, and the space from the line pressure (7) to the throttle pressure (16) increases.

Consequently, the throttle pressure (16) increases, and the valve is balanced. Contrarily, when the engine torque lowers and the negative pressure in the intake line lowers (similar to vacuum), force of the rod to depress the valve lowers, and the throttle pressure (16) also lowers. When a pressure regulated by the throttle back-up valve (described in the subsequent paragraph) is led to the circuit (17), a high pressure is applied through the space from the circuit (17) to the throttle pressure (16). Consequently, the VTV is unbalanced, the throttle pressure (16) becomes equal to the back-up pressure (17), and the valve is locked upward.

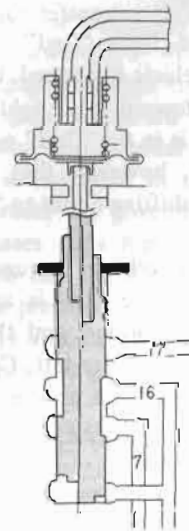

AT100

Fig. AT-15 Vacuum throttle valve

Throttle back-up valve (TBV)

Usually, this valve is depressed downward by the spring force, and the circuit (17) is drained upward.

As soon as the lever is shifted either to "2" or "1" range, line pressure is led from the circuit (4), the line pressure is applied to the area difference of the valve, the valve is depressed upward, the space from the circuit

AUTOMATIC TRANSMISSION

(4) to the circuit (17) is timely closed, and with the space from the circuit (17) to the upper drain being about to open, the back-up pressure (17) which is lower than the line pressure (4) by the pressure loss due to the space from the circuit (4) to the circuit (17) is balanced with the spring force.

Further, when speed is shifted from "2nd" to "Low" at the range "1," line pressure is led from the circuit (12), and the line pressure is applied upward to the bottom of the valve through the valve hole. Consequently, the valve is depressed upward, and locked. As the result, the space from the line pressure (4) to the back-up pressure (17) is closed completely, and the back-up pressure (17) is drained upward.

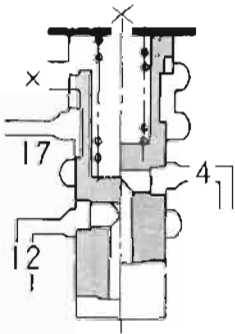

AT101

Fig. AT-16 Throttle back-up valve

Solenoid downshift valve (SDV)

This valve is a transfer valve which leads the line pressure (7) to (13) and transmits the same to the FSV and SSV when a kick-down signal is received from the downshift solenoid. Usually, the solenoid push rod and valve are locked upward by the spring in the lower end, and circuit from the line pressure (4) to the line pressure (13) is opened.

When kick-down is performed, the push rod operates, the valve is depressed downward, and the circuit from the line pressure (7) to the line pressure (13) opens. The line pressure (13) opposes the governor pressure (15) at the SSV and FSV, and thus, performs the downshift operation.

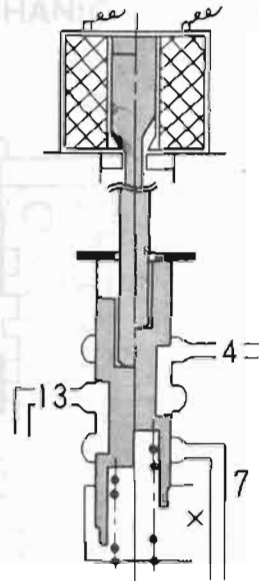

AT102

Fig. AT-17 Solenoid downshift valve

Second lock valve (SLV)

This valve is a transfer valve which assists the shift valve in order to decide the fixed "2nd" speed at the "2" range.

In the "D" range, the sum of the spring force and line pressure (3) applied upward exceeds the line pressure (2) which is applied to the valve area difference as the downward force. As the result, the valve is locked upward, and the circuit from the line pressure (8) to the line pressure (9) is opened.

Consequently, the FSV becomes the "2nd" speed condition, and line pressure is led to the band servo engaging circuit (9) only when the line pressure (1) is released to the line pressure (8).

In the "2" range, the upward force is retained only on the spring, and the downward line pressure (2) exceeds the upward force.

As the result, the valve is locked downward, the line pressure (2) is released to (9) regardless of the operating condition of the FSV, and the band servo is engaged.

2nd-3rd timing valve (TMV)

This valve is a transfer valve which switches the by-pass circuit of the

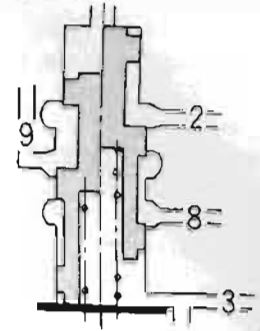

AT103

Fig. AT-18 Second lock valve

orifice (22) in the front clutch pressure circuit (11) in response to the vehicle speed and the throttle condition. A force created when the governor pressure (15) applies to the bottom of the TMV is used for the upward force, and a force created when the spring force and the throttle pressure apply to the top of the TMV is used for the downward force.

When the throttle pressure (16) is lower than the governor pressure (15), the upward force exceeds the downward force, the valve is locked upward, and passage from the circuit (10) ("2nd" from the "Top") to the circuit (11) is closed. Consequently, the line pressure (10) is led to the front clutch circuit (11) through the orifice (22), and thus, the oil pressure is transmitted slowly. However, under the normal shifting, the throttle pressure (16) has a pressure exceeding a certain level, and the downward force exceeds the upward force. As the result, the valve is locked downward, the passage from the circuit (10) to the circuit (11) is opened, and the orifice (22) is disregarded.

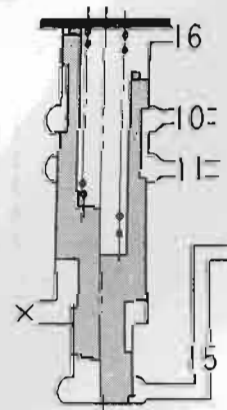

AT104

Fig. AT-19 "2nd-3rd" timing valve

CHASSIS

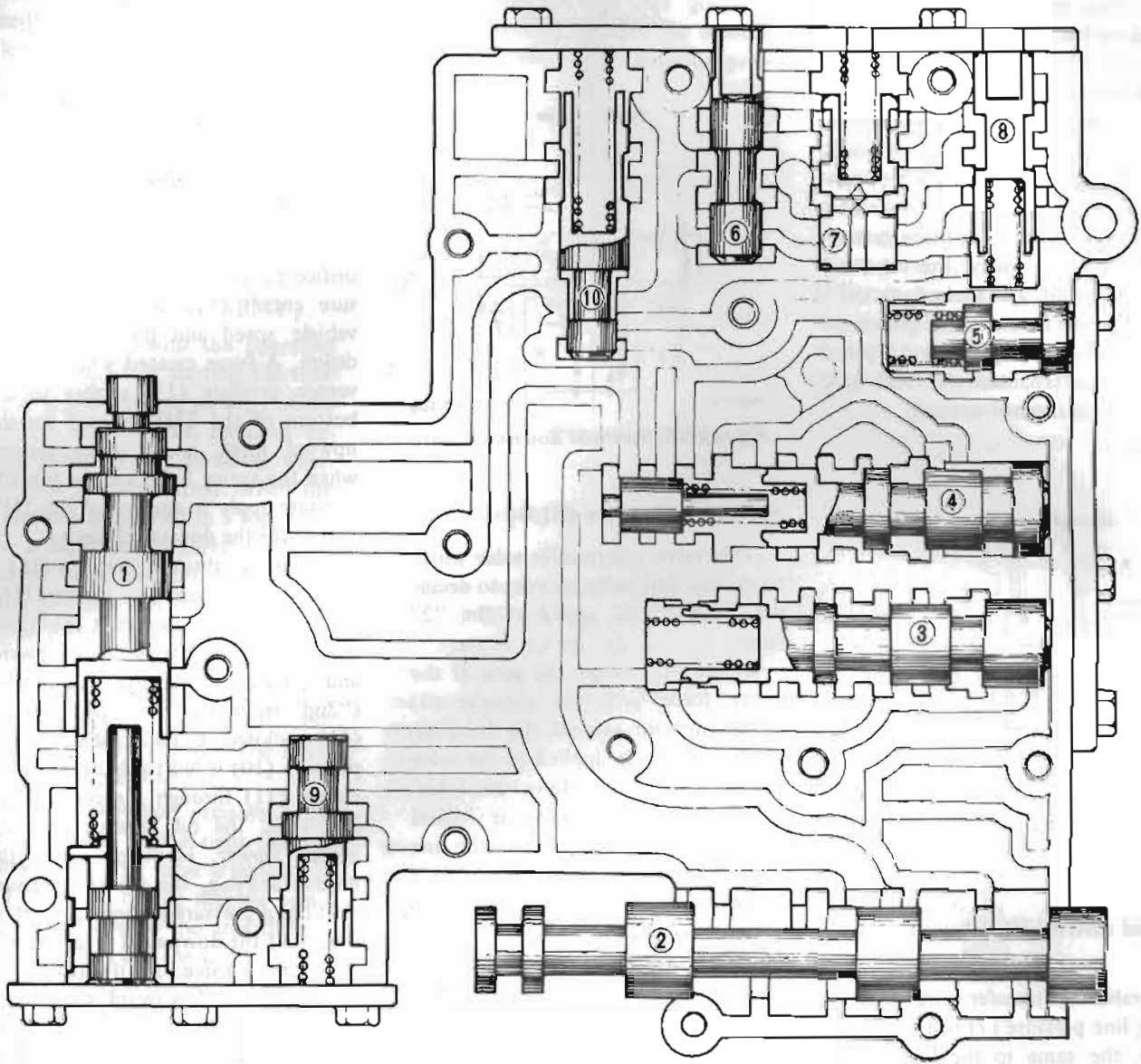

AT094

- | | |
|-----------------------------|-----------------------------|
| 1 Pressure regulating valve | 6 Vacuum throttle valve |
| 2 Manual valve | 7 Throttle back-up valve |
| 3 1st-2nd shift valve | 8 Solenoid down shift valve |
| 4 2nd-3rd shift valve | 9 Second lock valve |
| 5 Pressure modifier valve | 10 2 - 3 timing valve |

Fig. AT-20 Control valve

AUTOMATIC TRANSMISSION

HYDRAULIC SYSTEM AND MECHANICAL OPERATION

The operating system of oil pressure in each range is described below:

The oil pressure in each circuit shown in the illustration is classified as follows according to the function. (The numerals show the circuit numbers.)

Pressure source of the line: 7

Operating line pressure for friction elements:

1, 2, 3, 4, 5, 6, 8, 9, 10, 11, 12.

Auxiliary line pressure: 13

Pressure of throttle system:

16, 17, 18, 19.

Others: 14, 15

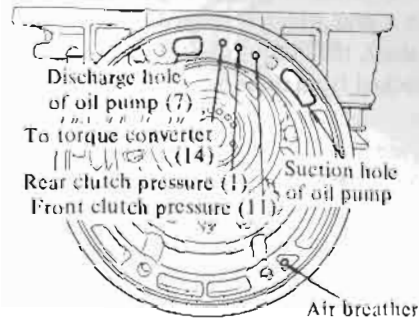

AT106

Fig. AT-22 Identification of oil channels in case front face

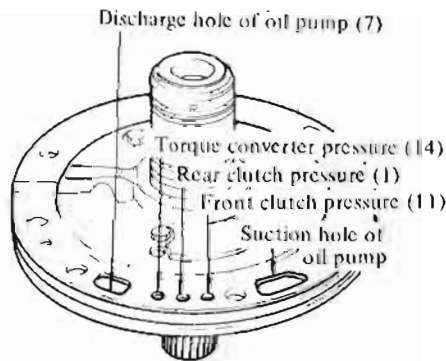

AT105

Fig. AT-21 Identification of oil channels in oil pump

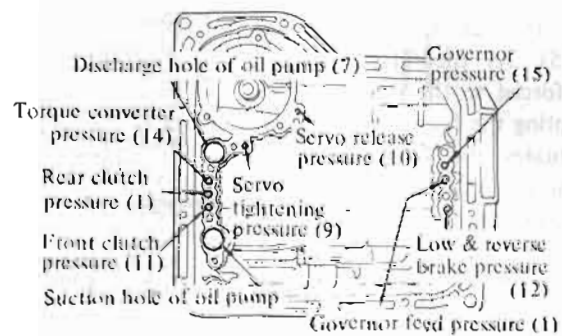

AT107

Fig. AT-23 Identification of oil channels in case face

"P" range (Park)

The operation of clutches and band are functionally quite the same as in "Neutral."

In parking, however, as the parking pawl meshes in a gear which is splined to the output shaft, the output shaft is mechanically locked from rotating.

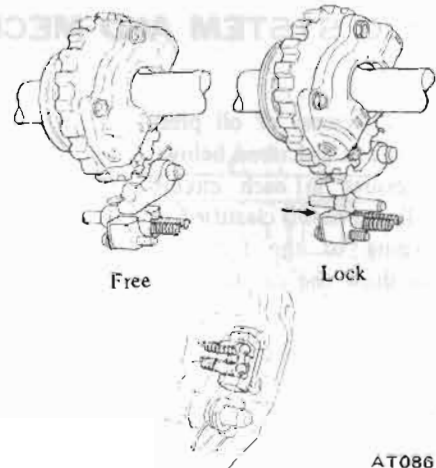

AT086

Fig. AT-24 Parking mechanism

The oil discharged from the oil pump is fed to each part in a similar manner to that of the "N" range. The oil having the line pressure (7) which has been introduced to the manual valve (2) reaches the "1st-2nd" shift valve (3) through the line pressure circuit (5). As the "1st-2nd" shift valve is forced to the right-hand side by the spring the line pressure (5) and (12) actuates the low and reverse brake through the groove. Also, the parking pawl engages with the outer teeth of the oil distributor by the manual lever, mechanically locking the output shaft.

Range		Gear ratio	Clutch		Low & reverse brake	Band servo		One way clutch	Parking pawl
			Front	Rear		Operation	Release		
Park					on				on
Reverse		2.182	on		on		on		
Neutral									
Drive	D1 Low	2.458		on				on	
	D2 Second	1.458		on		on			
	D3 Top	1.000	on	on		(on)	on		
2	Second	1.458		on		on			
1	I2 Second	1.458		on		on			
	I1 Low	2.458		on	on				

AUTOMATIC TRANSMISSION

"P" range (Park)

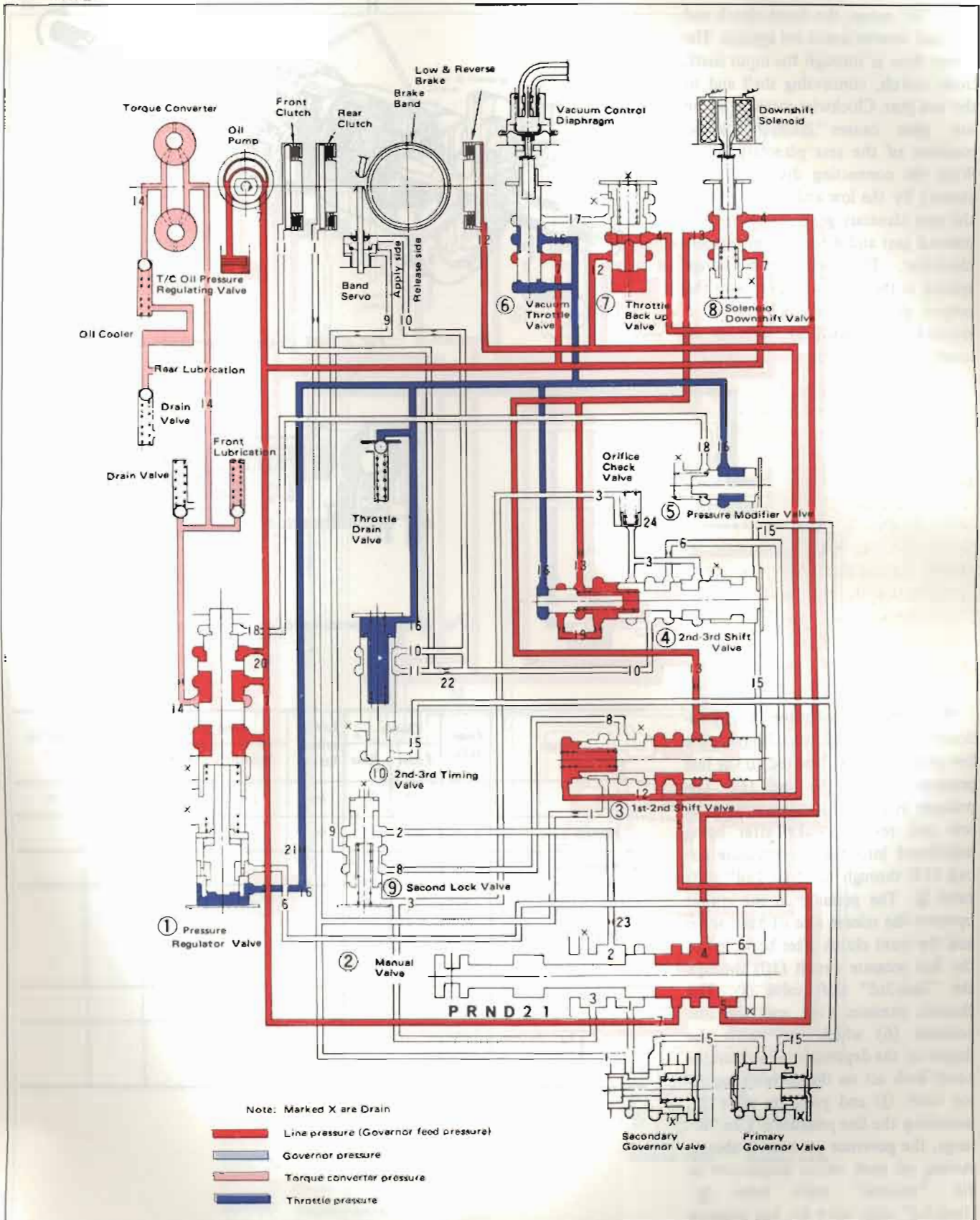
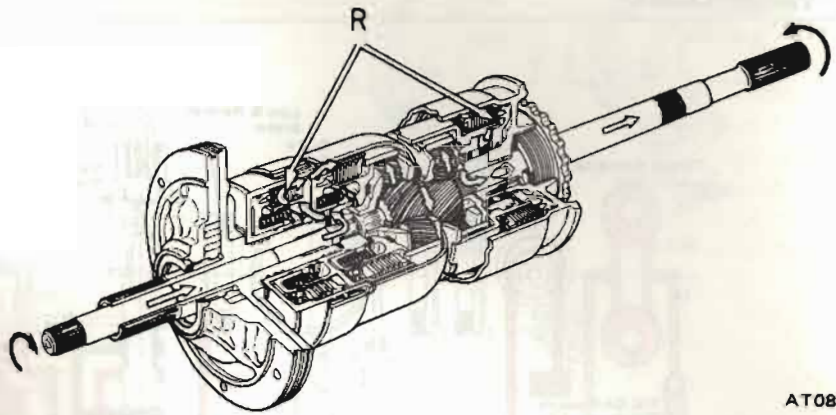

Fig. AT-25 Oil pressure circuit diagram — "P" range (Park)

CHASSIS

"R" range (Reverse)

In "R" range, the front clutch and low and reverse brake are applied. The power flow is through the input shaft, front clutch, connecting shell and to the sun gear. Clockwise rotation of the sun gear causes counterclockwise rotation of the rear planetary gears. With the connecting drum held stationary by the low and reverse brake, the rear planetary gears rotate the rear internal gear and drive flange counterclockwise. The rear drive flange splined to the output shaft rotates the output shaft counterclockwise at a reduced speed with an increase in torque for reverse gear.



AT084

Fig. AT-26 Power transmission during "R" range

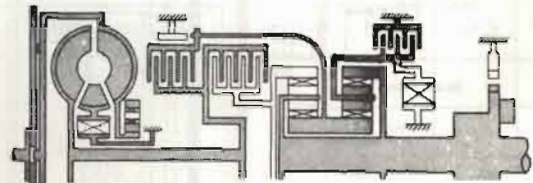

AT085

Fig. AT-27 Operation of each mechanism during "R" range

When the manual valve ② is positioned at "R" range, the oil having the line pressure (7) is directed to the line pressure circuits (5) and (6). The pressure in the circuit ⑤ actuates the low and reverse brake after being introduced into the line pressure circuit (12) through the "1st-2nd" shift valve ③. The pressure in the circuit operates the release side of band servo and the front clutch after being led to the line pressure circuit (10) through the "2nd-3rd" shift valve ④. The throttle pressure (16) and the line pressure (6) which vary with the degree of the depression of accelerator pedal both act on the pressure regulator valve ① and press its valve ①, increasing the line pressure (7). In "R" range, the governor pressure is absent, making all such valves inoperative as the "1st-2nd" shift valve ③, "2nd-3rd" shift valve ④, and pressure modifier valve ⑥.

Range	Gear ratio	Clutch		Low & reverse brake	Band servo		One way clutch	Parking pawl
		Front	Rear		Operation	Release		
Park				on				on
Reverse	2.182	on		on		on		
Neutral								
Drive	D1 Low	2.458		on			on	
	D2 Second	1.458		on	on			
	D3 Top	1.000	on	on	(on)	on		
2	Second	1.458		on	on			
1	l ₂ Second	1.458		on	on			
	l ₁ Low	2.458		on	on			

AUTOMATIC TRANSMISSION

"R" range (Reverse)

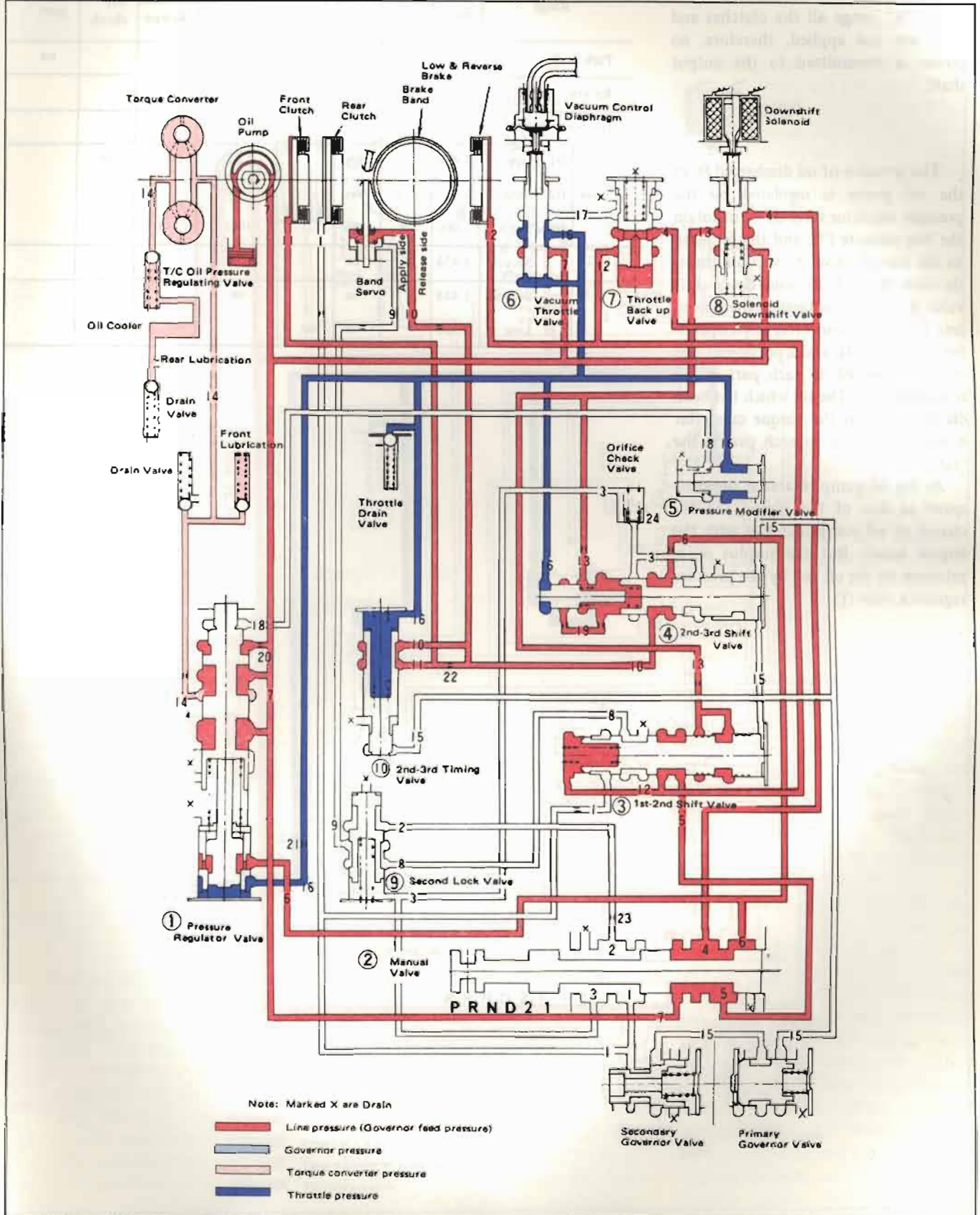

Fig. AT-28 Oil pressure circuit diagram — "R" range (Reverse)

CHASSIS

"N" range (Neutral)

In "N" range all the clutches and band are not applied, therefore, no power is transmitted to the output shaft.

The pressure of oil discharged from the oil pump is regulated by the pressure regulator valve ① to maintain the line pressure (7), and the oil is led to the manual valve ②, vacuum throttle valve ⑥, and solenoid down shift valve ⑧. The oil is further introduced into the torque converter at its operating pressure (14), and a portion of this oil is distributed to each part as the front lubricant. The oil which has been discharged from the torque converter is also distributed to each part as the rear lubricant.

As the oil pump rotates at the same speed as that of the engine, the discharge of oil pump increases with the engine speed. But the surplus oil is returned to the oil pan by the pressure regulator valve ①.

Range		Gear ratio	Clutch		Low & reverse brake	Band servo		One way clutch	Parking pawl
			Front	Rear		Operation	Release		
Park					on				on
Reverse		2.182	on		on		on		
Neutral									
Drive	D1 Low	2.458		on				on	
	D2 Second	1.458		on		on			
	D3 Top	1.000	on	on		(on)	on		
2	Second	1.458		on		on			
1	1 ₂ Second	1.458		on		on			
	1 ₁ Low	2.458		on	on				

AUTOMATIC TRANSMISSION

"N" range (Neutral)

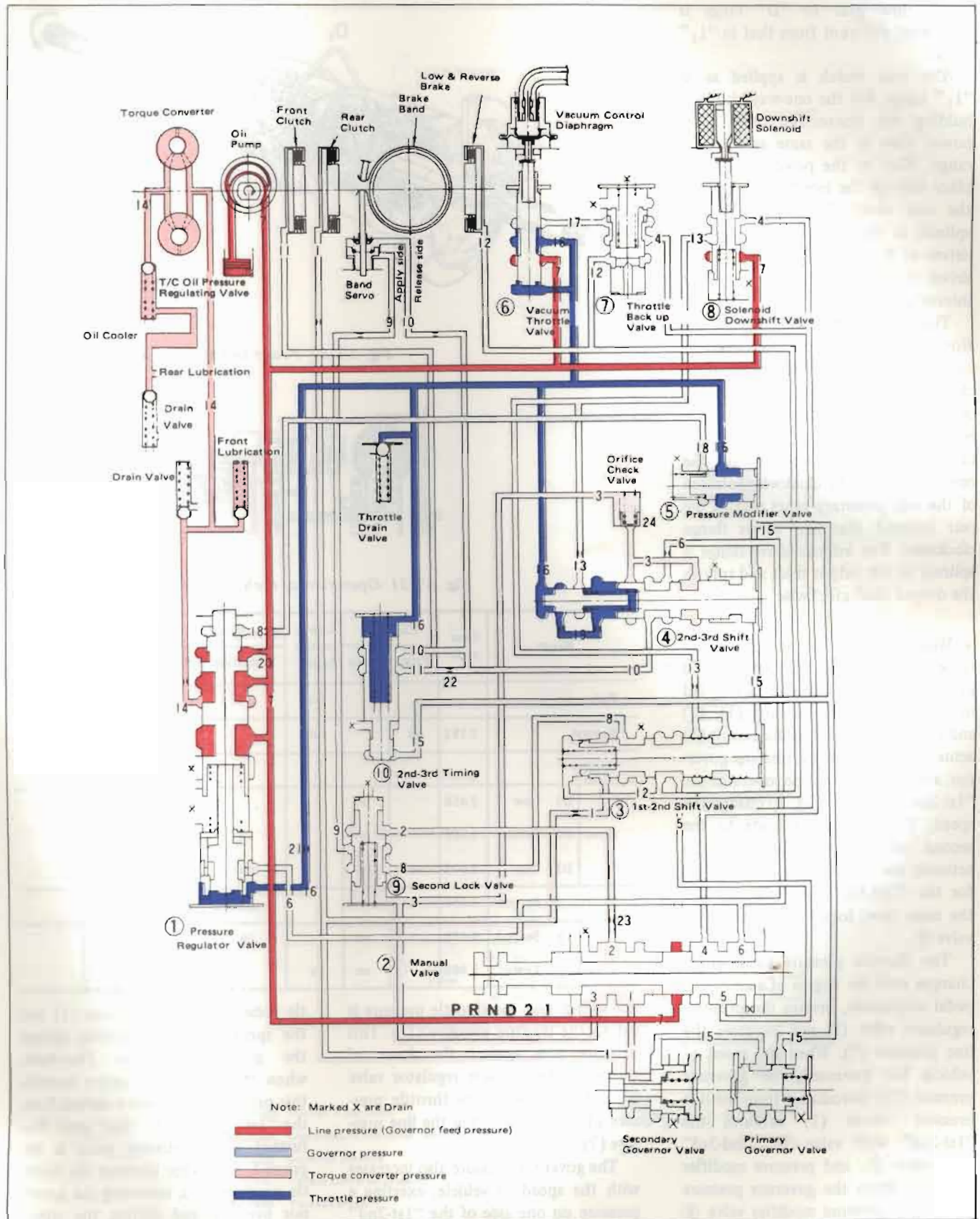

Fig. AT-29 Oil pressure circuit diagram -- "N" range (Neutral)

"D₁" range (Low gear)

The low gear in "D" range is somewhat different from that in "1₁" range.

The rear clutch is applied as in "1₁" range, but the one-way clutch is holding the connecting drum. The power flow is the same as in "1₁" range. That is, the power flow takes place through the input shaft and into the rear clutch. The input shaft is splined to the rear clutch drum and drives it. Rotation of the rear clutch drives the rear clutch hub and front internal gear.

The front internal gear rotates the front planetary gears clockwise to cause the sun gear to rotate counterclockwise. Counterclockwise rotation of the sun gear turns the rear planetary gears clockwise. With the rear planetary carrier held stationary by the one-way clutch, the clockwise rotation of the rear planetary gears rotates the rear internal gear and drives flange clockwise. The internal drive flange is splined to the output shaft and rotates the output shaft clockwise.

When the manual valve is positioned at "D," the line pressure (7) introduced into the manual valve is led to the line pressure circuits (1), (2) and (3). The pressure in the circuit (1) actuates the rear clutch and the governor, and at the same time, operates the "1st-2nd" shift valve (3) to change the speed. The circuit (2) leads to the second lock valve (9). The circuit (3) actuates the "2nd-3rd" shift valve (4) for the "2nd-3rd" speed change, and the same time, locks the second lock valve (9).

The throttle pressure (16) which changes with the degree of accelerator pedal depression, presses the pressure regulator valve (1) and increases the line pressure (7). When the speed of vehicle has increased, the governor pressure (15) introduced from the line pressure circuit (1) actuates the "1st-2nd" shift valve (3), "2nd-3rd" shift valve (4), and pressure modifier valve (5). When the governor pressure is high, the pressure modifier valve (5) acts in such a direction as to compress

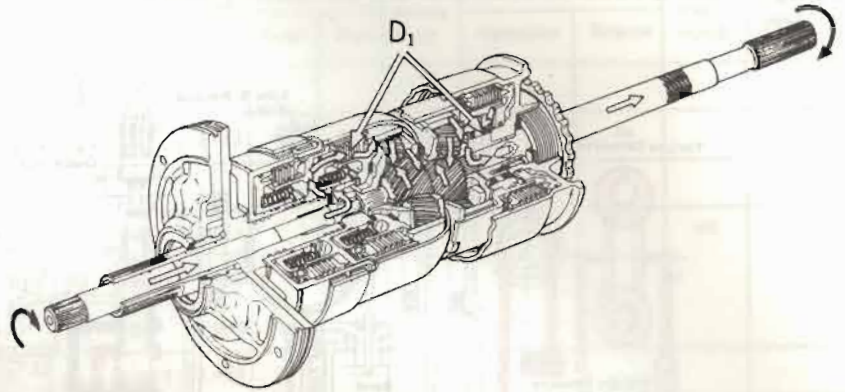

AT080

Fig. AT-30 Power transmission during "D1" range

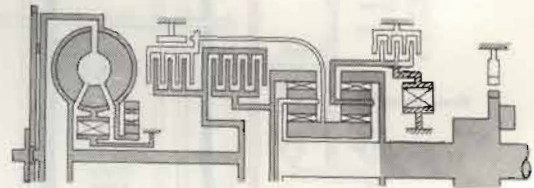

AT081

Fig. AT-31 Operation of each mechanism during "D1" range

Range	Gear ratio	Clutch		Low & reverse brake	Band servo		One way clutch	Parking pawl
		Front	Rear		Operation	Release		
Park				on				on
Reverse	2.182	on		on		on		
Neutral								
Drive	D1 Low	2.458		on				on
	D2 Second	1.458		on		on		
	D3 Top	1.000	on	on		(on)	on	
2	Second	1.458		on		on		
1	1 ₂ Second	1.458		on		on		
	1 ₁ Low	2.458		on	on			

the spring, and the throttle pressure is led to the throttle pressure (18). This pressure acts against the force of spring of the pressure regulator valve (1) and also against the throttle pressure (16), thus lowering the line pressure (7).

The governor pressure also increases with the speed of vehicle, exerting a pressure on one side of the "1st-2nd" shift valve, and counteracts the throt-

tle pressure (19), line pressure (1), and the spring which are exerting against the governor pressure. Therefore, when the governor pressure exceeds this pressure, the speed is shifted from the "1st" gear to the "2nd" gear. The further the accelerator pedal is depressed, the higher becomes the throttle pressure (19), increasing the governor pressure and shifting the speed change point to the higher side.

AUTOMATIC TRANSMISSION

"D1" range (Low gear)

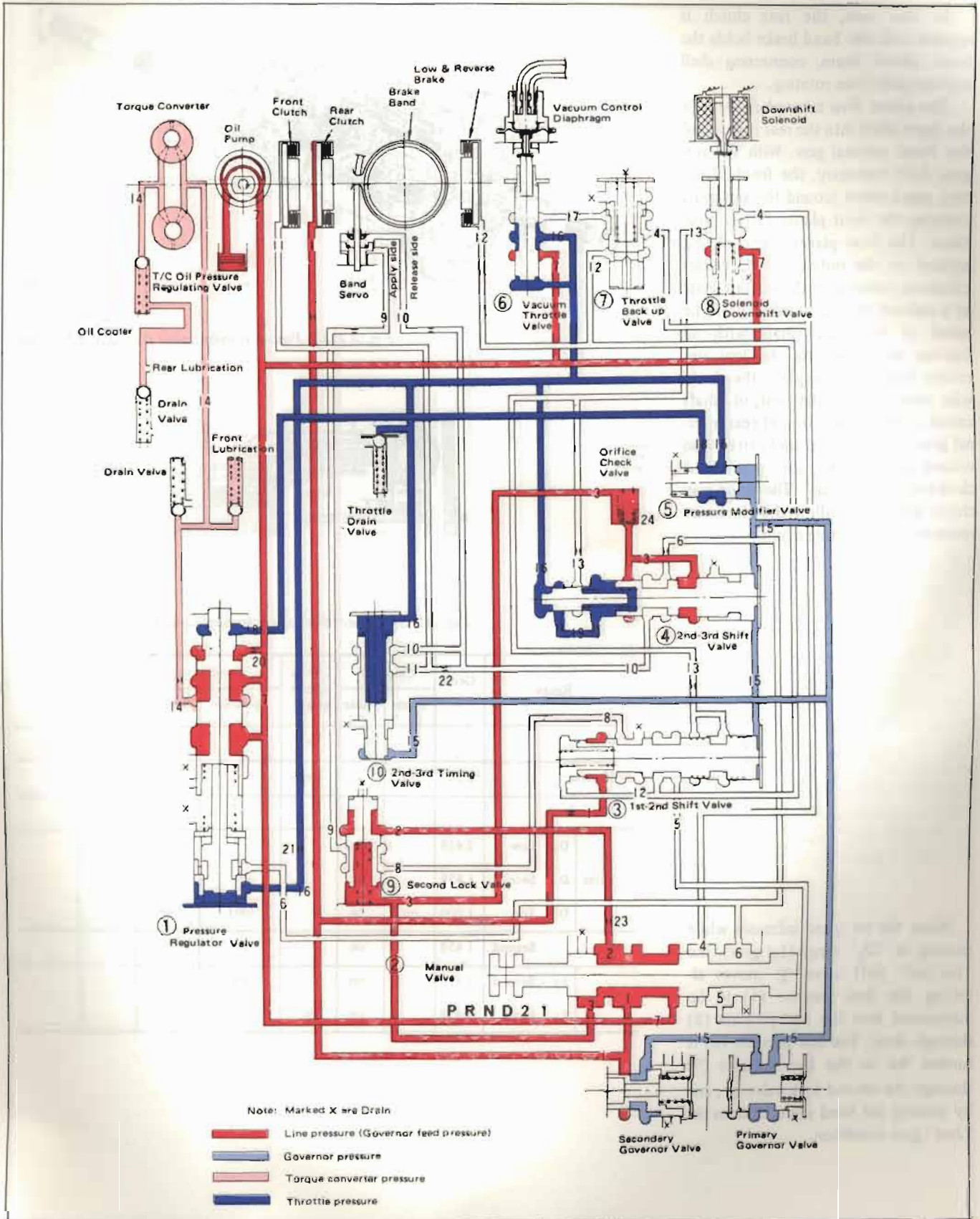
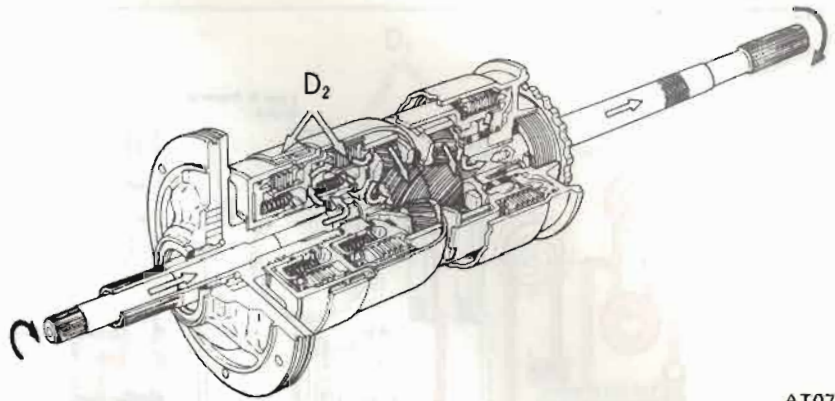

Fig. AT-32 Oil pressure circuit diagram — "D1" range (Low gear)

"D₂" range (2nd gear)

In this case, the rear clutch is applied and the band brake holds the front clutch drum, connecting shell and sun gear from rotating.

The power flow takes place through the input shaft into the rear clutch and the front internal gear. With the sun gear held stationary, the front planetary gears rotate around the sun gear, carrying the front planet carrier with them. The front planet carrier, being splined to the output shaft, causes clockwise rotation of the output shaft at a reduced speed compared with the speed of the input shaft with an increase in torque. As the low and reverse brake is not applied, the clockwise rotation of the output shaft causes clockwise rotation of rear internal gear and the rear planet carrier also rotates around the sun gear in a clockwise direction. The one-way clutch will act to allow the clockwise rotation of connecting drum.



AT078

Fig. AT-33 Power transmission during "D₂" range

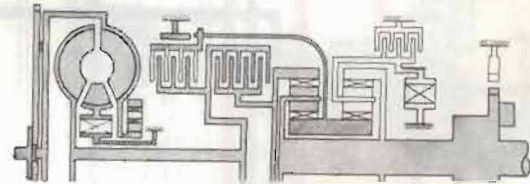

AT079

Fig. AT-34 Operation of each mechanism during "D₂" range

Range	Gear ratio	Clutch		Low & reverse brake	Band servo		One way clutch	Parking pawl
		Front	Rear		Operation	Release		
Park				on				on
Reverse	2.182	on		on		on		
Neutral								
Drive	D1 Low	2.458		on				on
	D2 Second	1.458		on		on		
	D3 Top	1.000	on	on		(on)	on	
2	Second	1.458		on		on		
1	1 ₂ Second	1.458		on		on		
	1 ₁ Low	2.458		on	on			

When the car speed increases while running at "D₁" range (1st gear), the "1st-2nd" shift valve ③ moves allowing the line pressure (1) to be introduced into the line pressure (8) through itself. The line pressure (8) is further led to the line pressure (9) through the second lock valve ④, and by locking the band servo, obtains the "2nd" gear condition.

AUTOMATIC TRANSMISSION

"D₂" range (2nd gear)

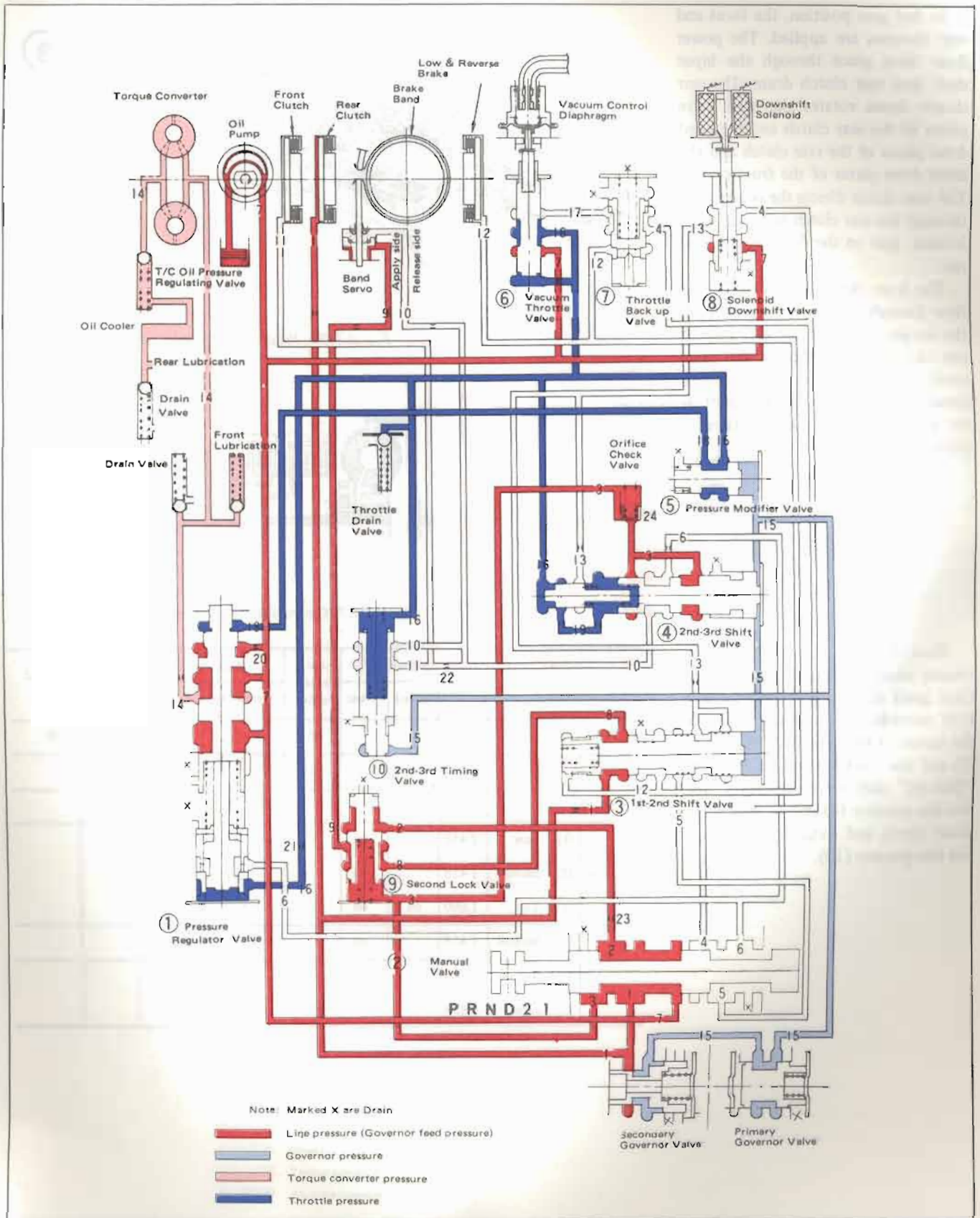

Fig. AT-35 Oil pressure circuit diagram — "D₂" range (2nd gear)

CHASSIS

"D₃" range (Top gear)

In 3rd gear position, the front and rear clutches are applied. The power flow takes place through the input shaft into rear clutch drum. The rear clutch drum rotates the steel drive plates of the rear clutch and the lined drive plates of the rear clutch and the lined drive plates of the front clutch. The rear clutch directs the power flow through the rear clutch hub and front internal gear to the front planet carrier.

The front clutch directs the power flow through the connecting shell to the sun gear. With the sun gear and the rear clutch hub driven at the same speed, the front planet assembly is forced to rotate the output shaft at the same speed in the direction to provide the top gear.

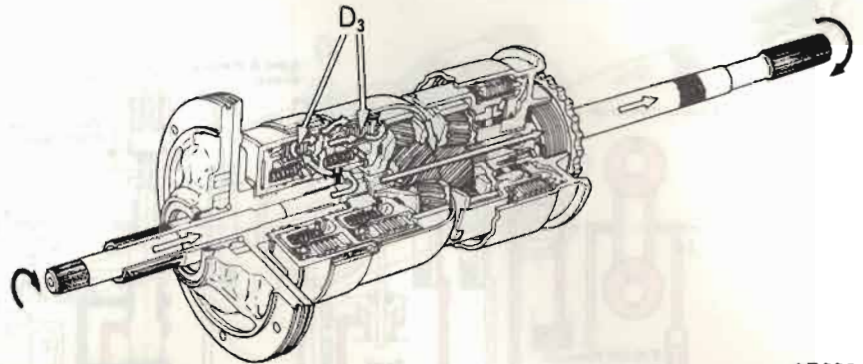

AT082

Fig. AT-36 Power transmission during "D₃" range

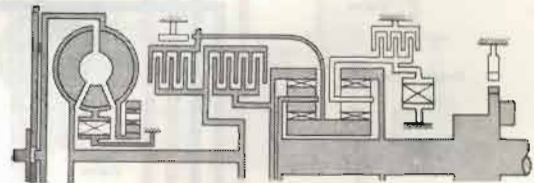

AT083

Fig. AT-37 Operation of each mechanism "D₃" range

When the car speed further increases while running at "D₂" range (2nd gear) and the governor pressure (15) exceeds the combined force of the spring of the "2nd-3rd" shift valve (4) and the throttle pressure (19), the "2nd-3rd" shift valve (4) moves, and the line pressure (8) acts to release the front clutch and band servo through the line pressure (10).

Range		Gear ratio	Clutch		Low & reverse brake	Band servo		One way clutch	Parking pawl
			Front	Rear		Operation	Release		
Park					on				on
Reverse		2.182	on		on		on		
Neutral									
Drive	D1 Low	2.458		on				on	
	D2 Second	1.458		on		on			
	D3 Top	1.000	on	on		(on)	on		
2		Second		on		on			
1	1 ₂ Second	1.458		on		on			
	1 ₁ Low	2.458		on	on				

AUTOMATIC TRANSMISSION

"D₃" range (Top gear)

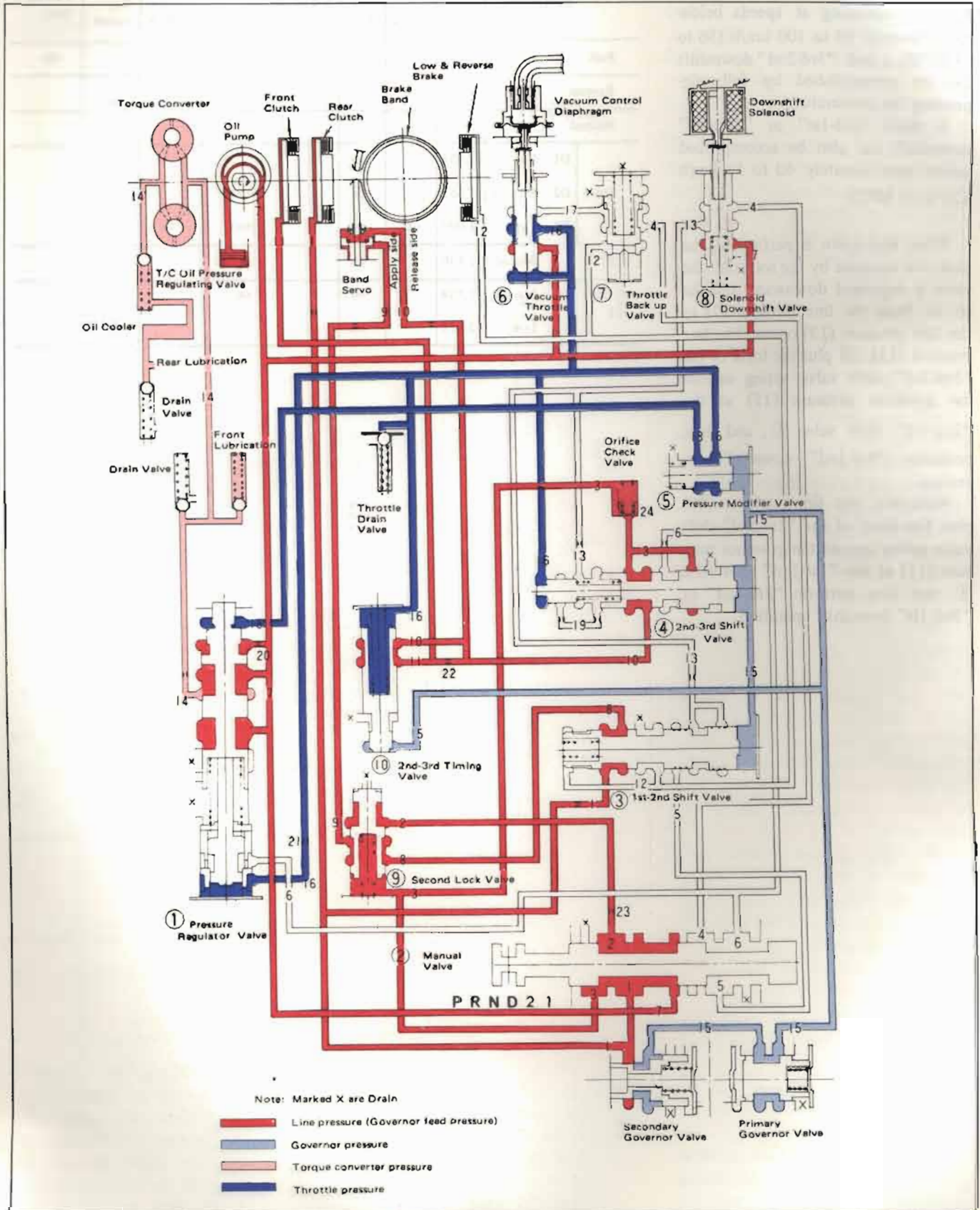

Fig. AT-38 Oil pressure circuit diagram — "D₃" range (Top gear)

“D” range kick-down

While operating at speeds below approximately 90 to 100 km/h (56 to 63 MPH), a kick “3rd-2nd” downshift can be accomplished by fully depressing the accelerator.

A kick “3rd-1st” or “2nd-1st” downshift can also be accomplished below approximately 40 to 50 km/h (25 to 31 MPH).

When kick-down is performed, the push rod operates by the solenoid, the valve is depressed downward, and the circuit from the line pressure (7) to the line pressure (13) opens. The line pressure (13), (3) plus the force of the “2nd-3rd” shift valve spring oppose the governor pressure (15) at the “2nd-3rd” shift valve ④, and thus, performs “3rd-2nd” downshift operation.

Moreover, the line pressure (13) plus the force of the “1st-2nd” shift valve spring oppose the governor pressure (15) at the “1st-2nd” shift valve ③, and thus, perform “3rd-2nd” or “2nd-1st” downshift operation.

Range		Gear ratio	Clutch		Low & reverse brake	Band servo		One way clutch	Parking pawl
			Front	Rear		Operation	Release		
Park					on				on
Reverse		2.182	on		on		on		
Neutral									
Drive	D1 Low	2.458		on				on	
	D2 Second	1.458		on		on			
	D3 Top	1.000	on	on		(on)	on		
2		Second		on		on			
1	1 ₂ Second	1.458		on		on			
	1 ₁ Low	2.458		on	on				

AUTOMATIC TRANSMISSION

"D" range kick-down (shift valves in 2nd gear position)

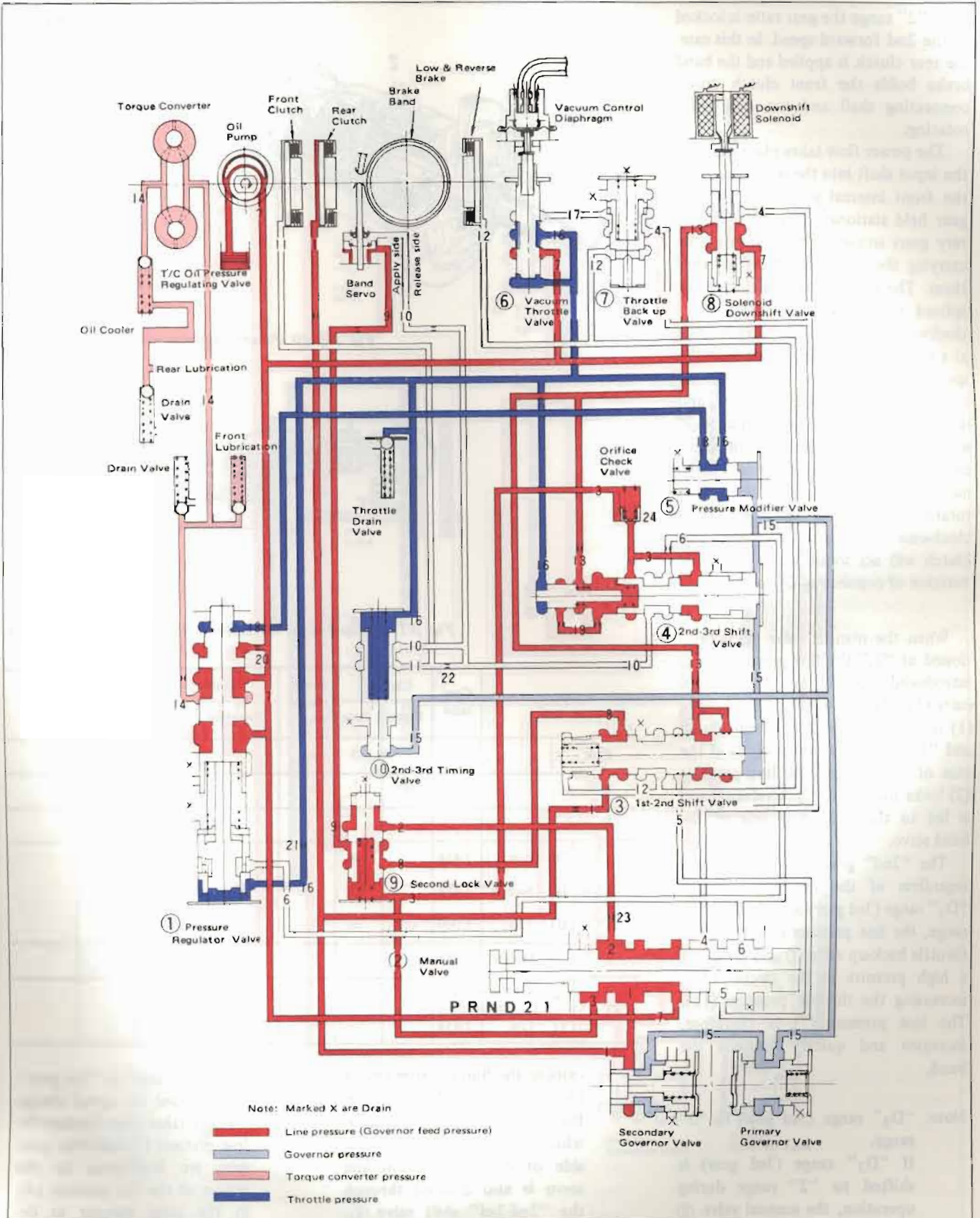
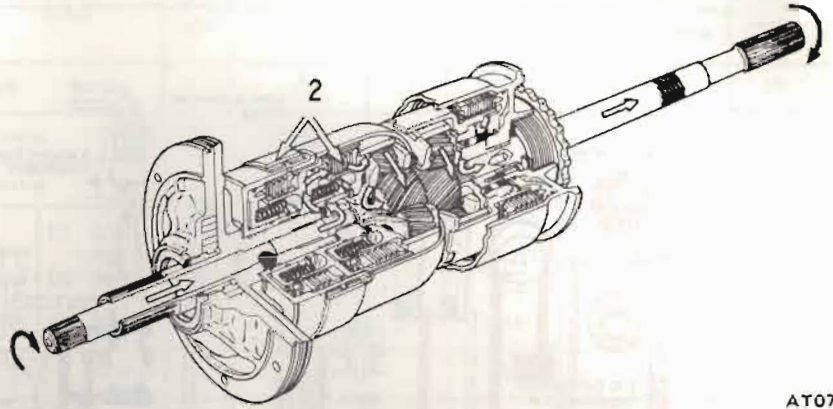

Fig. AT-39 Oil pressure circuit diagram — "D" range kick down (shift valves in 2nd gear position)

"2" range (2nd gear)

In "2" range the gear ratio is locked to the 2nd forward speed. In this case, the rear clutch is applied and the band brake holds the front clutch drum, connecting shell and sun gear from rotating.

The power flow takes place through the input shaft into the rear clutch and the front internal gear. With the sun gear held stationary, the front planetary gears rotate around the sun gear, carrying the front planet carrier with them. The front planet carrier, being splined to the output shaft, causes clockwise rotation of the output shaft at a reduced speed compared with the speed of the input shaft with an increase in torque. As the low and reverse brake is not applied, the clockwise rotation of the output shaft causes clockwise rotation of rear internal gear and the rear planet carrier also rotates around the sun gear in a clockwise direction. The one-way clutch will act to allow the clockwise rotation of connecting drum.



AT078

Fig. AT-40 Power transmission during "2" range

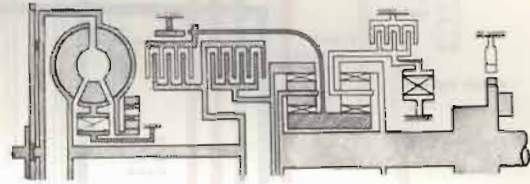

AT079

Fig. AT-41 Operation of each mechanism during "2" range

When the manual valve ② is positioned at "2," the line pressure (7) is introduced into the line pressure circuits (1), (2) and (4). The line pressure (1) is led to the governor, rear clutch and "1st-2nd" shift valve ③ as in the case of "D" range. The line pressure (2) locks the second lock valve ⑨ and is led to the tightening side of the band servo.

The "2nd" gear is therefore fixed regardless of the car speed. When "D₃" range (3rd gear) is shifted to "2" range, the line pressure (4) enters the throttle back-up valve ⑦ and produces a high pressure in the circuit (17), increasing the throttle pressure (16). The line pressure (7) is, therefore, increases and quickly tightens the band.

Note: "D₃" range (3rd gear) to "2" range.

If "D₃" range (3rd gear) is shifted to "2" range during operation, the manual valve ② is also shifted to "2" position,

Range	Gear ratio	Clutch		Low & reverse brake	Band servo		One way clutch	Parking pawl
		Front	Rear		Operation	Release		
Park				on				on
Reverse	2.182	on		on		on		
Neutral								
Drive	D1 Low	2.458		on				on
	D2 Second	1.458		on		on		
	D3 Top	1.000	on	on		(on)	on	
2	Second	1.458		on		on		
1	1 ₂ Second	1.458		on		on		
	1 ₁ Low	2.458		on	on			

causing the line pressure circuit (3) to be drained. Therefore, the line pressure circuit (10) which is situated at the release side of the front clutch and servo is also drained through the "2nd-3rd" shift valve ④, forcing the speed to decrease

from "3rd gear" to "2nd gear." In this case the speed change quickly takes place because the line pressure (7) and other pressure are heightened by the action of the line pressure (4), in the same manner as described under "2" range.

AUTOMATIC TRANSMISSION

"2" range (2nd gear)

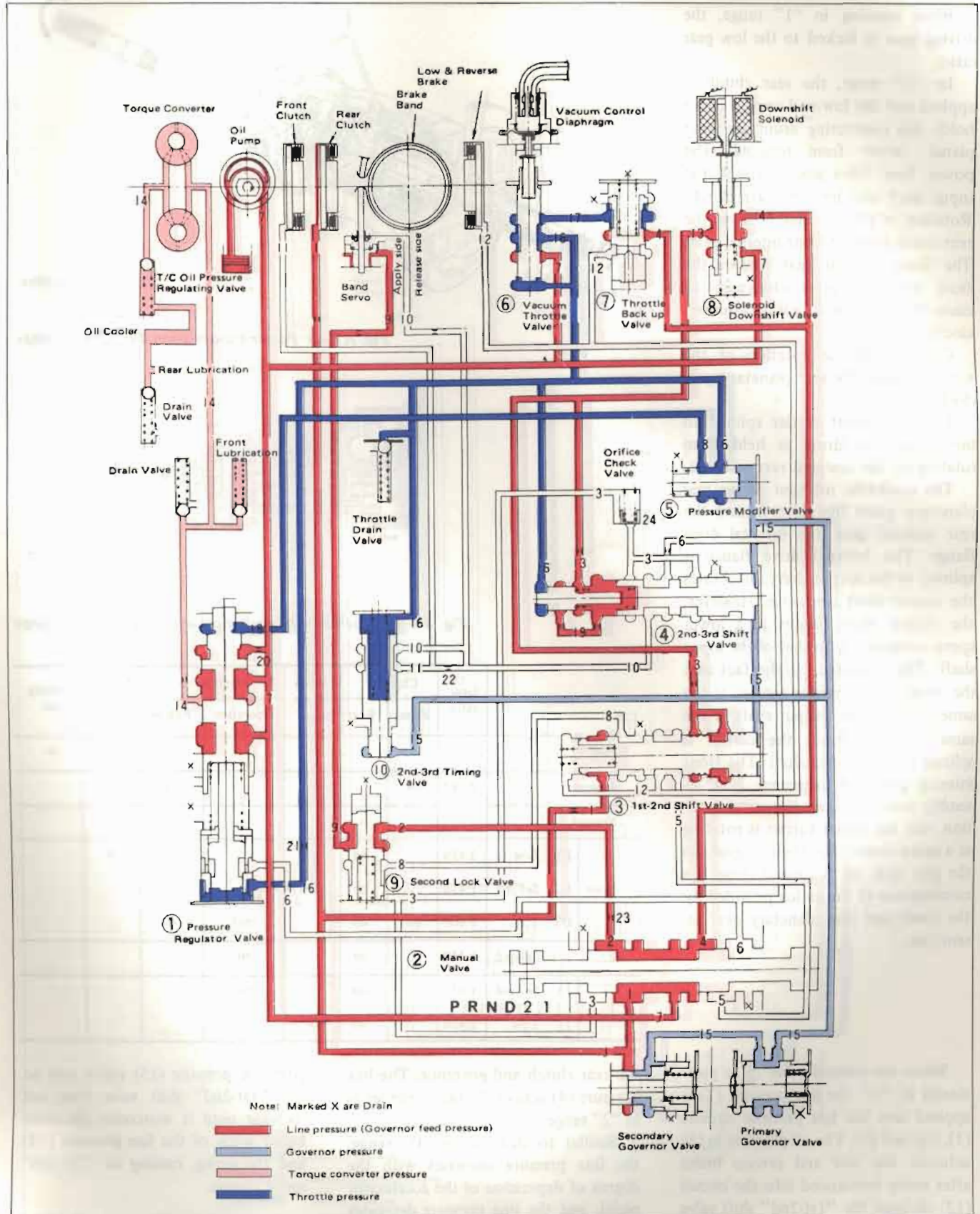

Fig. AT-42 Oil pressure circuit diagram — "2" range (2nd gear)

"1₁" range (Low gear)

When starting in "1" range, the driving gear is locked to the low gear ratio.

In "1" range, the rear clutch is applied and the low and reverse brake holds the connecting drum and rear planet carrier from rotating. The power flow takes place through the input shaft and into the rear clutch. Rotation of the rear clutch drives the rear clutch hub and front internal gear. The front internal gear rotates the front planetary gears clockwise to cause the sun gear to rotate counterclockwise.

Counterclockwise rotation of the sun gear turns the rear planetary gear clockwise.

The rear planet carrier splined to the connecting drum is held from rotating by the low and reverse brake.

The clockwise rotation of the rear planetary gears therefore rotates the rear internal gear and internal drive flange. The internal drive flange is splined to the output shaft and rotates the output shaft clockwise. However, the output shaft rotates at a lower speed compared with that of the input shaft. This is caused by the fact that the front planet carrier rotates at the same speed as the output shaft in the same direction since the carrier is splined to the output shaft. The front internal gear and planetary gear assembly are rotating in the same direction, but the planet carrier is rotating at a speed slower than the ring gear. So the gear ratio of this speed range is a combination of the ratios provided by the front and rear planetary gear assemblies.

When the manual valve ② is positioned at "1," the line pressure (7) is applied into the line pressure circuits (1), (4) and (5). The oil pressure in (5) actuates the low and reverse brake after being introduced into the circuit (12) through the "1st-2nd" shift valve ③, and the line pressure (1) acts on

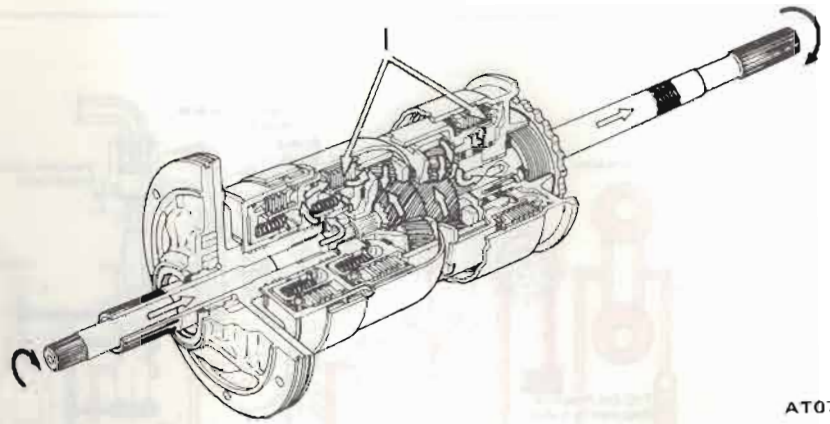

AT076

Fig. AT-43 Power transmission during "1₁" range

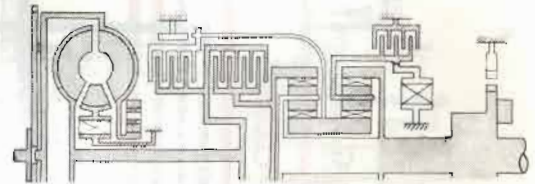

AT077

Fig. AT-44 Operation of each mechanism during "1₁" range

Range	Gear ratio	Clutch		Low & reverse brake	Band servo		One way clutch	Parking pawl
		Front	Rear		Operation	Release		
Park				on				on
Reverse	2.182	on		on		on		
Neutral								
Drive	D1 Low		on				on	
	D2 Second		on		on			
	D3 Top	on	on		(on)	on		
2	Second		on		on			
1	1 ₂ Second		on		on			
	1 ₁ Low		on	on				

the rear clutch and governor. The line pressure (4) acts in the same manner as in "2" range.

Similar to that of the "D" range, the line pressure increases with the degree of depression of the accelerator pedal, and the line pressure decreases with the increase of car speed. The

governor pressure (15) which acts on the "1st-2nd" shift valve does not increase until it overcomes the combined force of the line pressure (12) and the spring, causing no "1st-2nd" speed change.

AUTOMATIC TRANSMISSION

"1" range (Low gear)

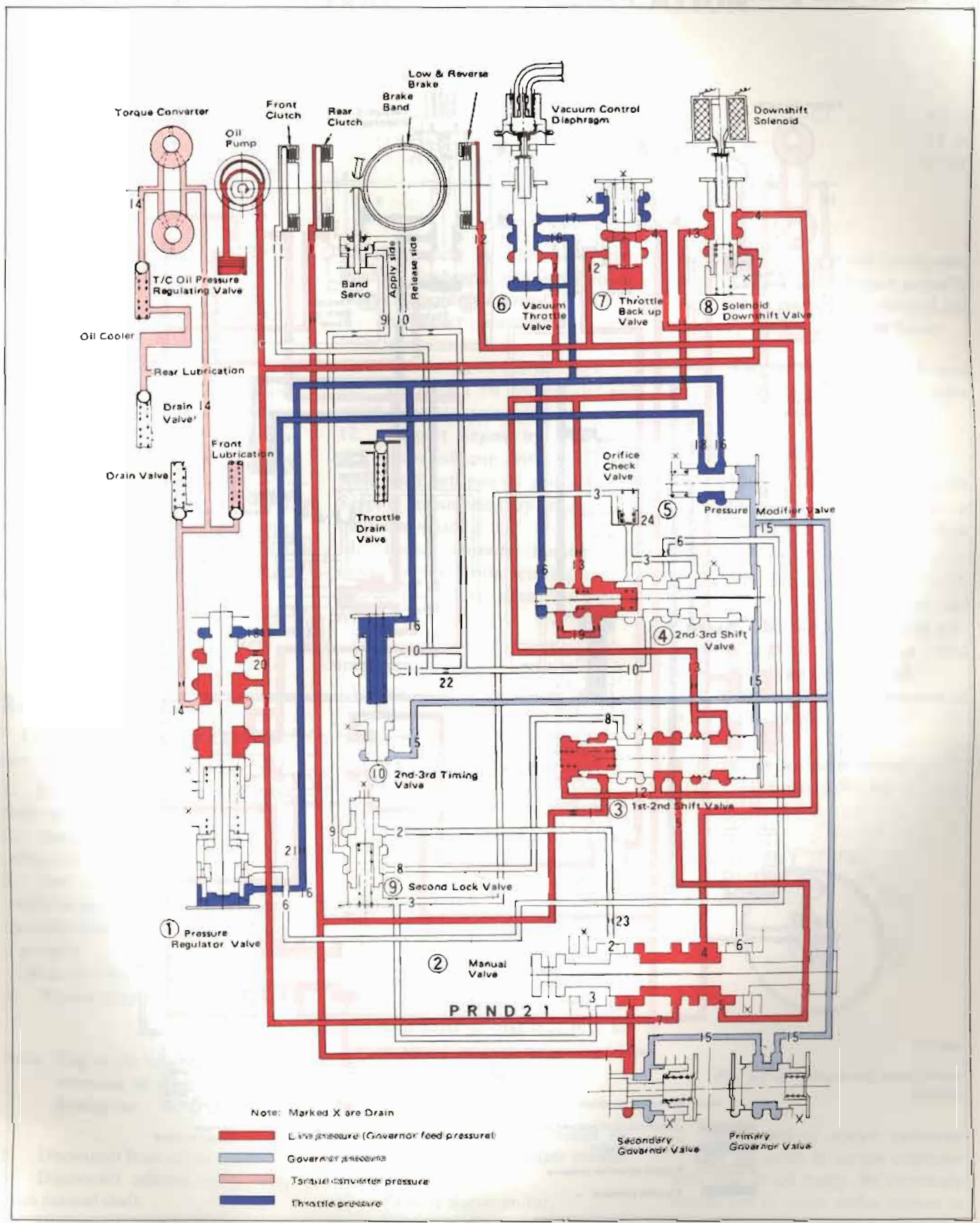

Fig. AT-45 Oil pressure circuit diagram — "1" range (Low gear)

CHASSIS

"1₂" range (2nd gear)

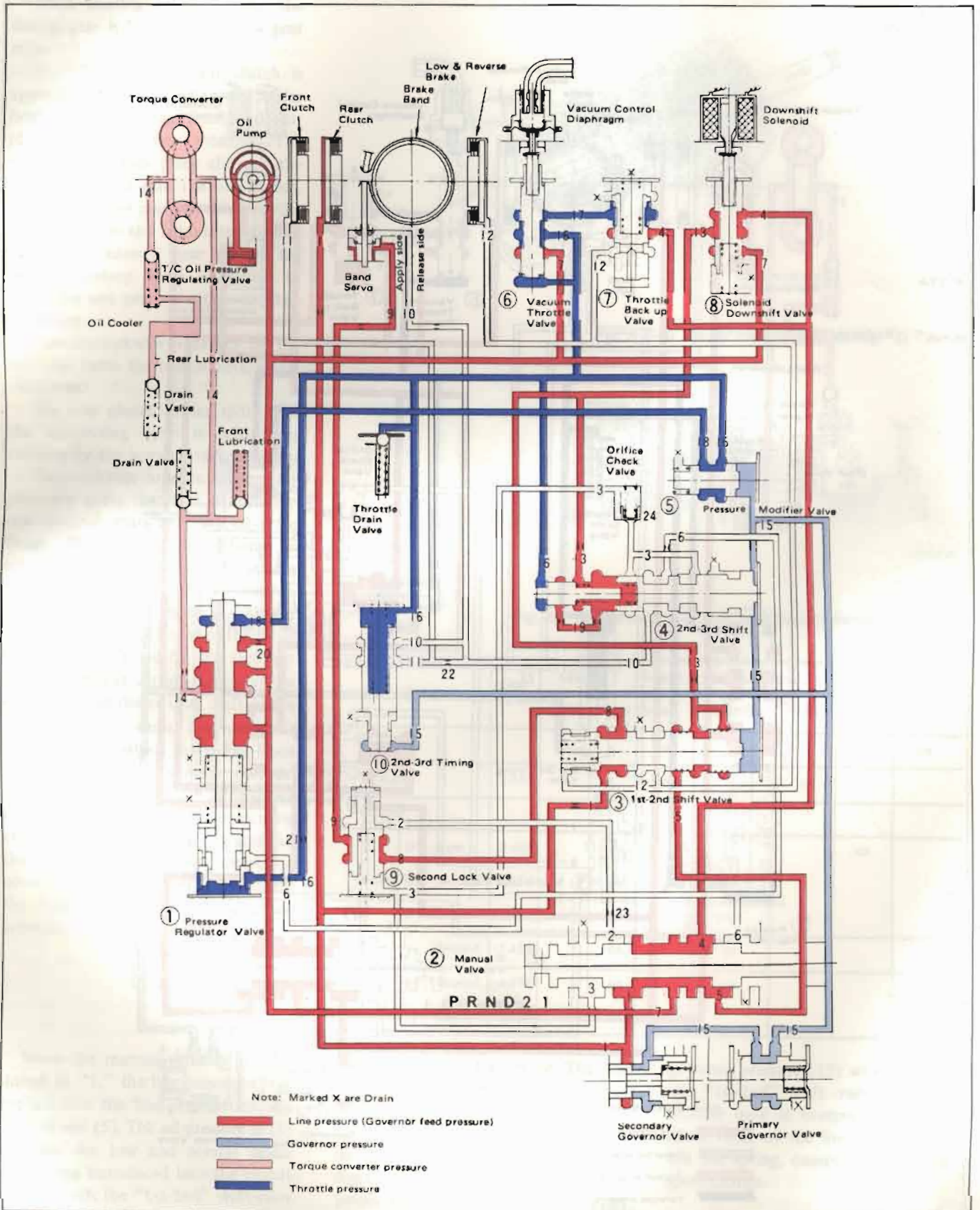

Fig. AT-46 Oil pressure circuit diagram — "1₂" range (2nd gear)

AUTOMATIC TRANSMISSION

REMOVAL AND INSTALLATION

CONTENTS

TRANSMISSION ASSEMBLY	AT-33	TRANSMISSION CONTROL LINKAGE	AT-35
Removal	AT-33	Removal and installation	AT-36
Installation	AT-33	Adjustment	AT-36

TRANSMISSION ASSEMBLY

When dismantling the automatic transmission from a vehicle, pay attention to the following points:

1. Before dismantling the transmission, rigidly inspect it by aid of the "Troubleshooting Chart," and dismount it only when considered to be necessary.
2. Dismount the transmission with utmost care; and when mounting, observe the tightening torque indicated on another table, not to exert excessive force.

Removal

In dismantling automatic transmission from vehicle, proceed as follows:

1. Disconnect battery ground cable from terminal.
2. Disengage torsion shaft from accelerator linkage.
3. Jack up vehicle and support its weight on safety stands. Recommend a hydraulic hoist or open pit be utilized, if available.

Make sure that safety is insured.

4. Remove propeller shaft.

Note: Plug up the opening in the rear extension to prevent oil from flowing out.

5. Disconnect front exhaust tube.
6. Disconnect selector range lever from manual shaft.
7. Disconnect wire connections at inhibitor switch.

8. Disconnect vacuum tube from vacuum diaphragm, and wire connections at downshift solenoid.
9. Disconnect speedometer cable from rear extension.
10. Disconnect oil charging pipe.
11. Disconnect oil cooler inlet and outlet tubes at transmission case.
12. Support engine by locating a jack under oil pan with a wooden block used between oil pan and jack. Support transmission by means of a transmission jack.
13. Detach converter housing dust cover. Remove bolts securing torque converter to drive plate. See Figure AT-47.

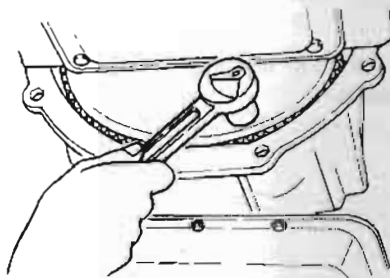

Fig. AT-47 Removing torque converter attaching bolts

Note: Before removing torque converter, scribe match marks on two parts so that they may be replaced in their original positions at assembly.

14. Remove rear engine mount securing bolts and crossmember mounting bolts.
15. Remove starter motor.
16. Remove bolts securing transmission to engine. After removing these

bolts, support engine and transmission with jack, and lower the jack gradually until transmission can be removed and take out transmission under the car.

Note: Plug up the opening such as oil charging pipe, oil cooler tubes, etc..

Installation

Installation of automatic transmission on vehicle is reverse order of removal. However, observe the following installation notes.

1. Drive plate runout

Turn crankshaft one full turn and measure drive plate runout with indicating finger of a dial gauge rested against plate. See Figure AT-48.

[Replace drive plate if in excess of 0.5 mm (0.020 in).]

- Maximum allowable runout:
0.3 mm (0.012 in)

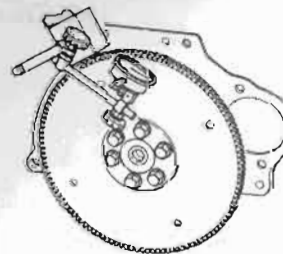
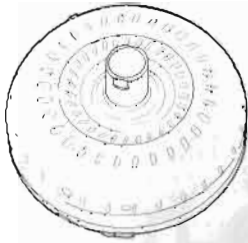

Fig. AT-48 Measuring drive plate runout

2. Installation of torque converter
Line up notch in torque converter with that in oil pump. Be extremely careful not to cause undue stresses in parts in installing torque converter. See Figure AT-49.

CHASSIS



AT116

Fig. AT-49 Torque converter aligning cut

3. When connecting torque converter to transmission, measure distance "A" to be certain that they are correctly assembled. See Figure AT-50.

Distance "A":

More than 21.5 mm (0.846 in)

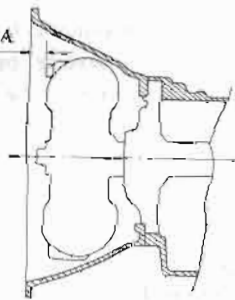

AT117

Fig. AT-50 Installing torque converter

4. Bolt converter to drive plate.

Note: Align chalk marks painted across both parts during disassembling processes.

5. After converter is installed, rotate crankshaft several turns and check to be sure that transmission rotates freely without binding.

6. Pour recommended automatic transmission fluid up to correct level through oil charge pipe.

7. Connect manual lever to shift rod. Operation should be carried out with manual and selector levers in "N."

8. Connect inhibitor switch wires.

Notes: a. Refer to covering topic under "Checking and adjusting inhibitor switch" on page AT-51.

b. Inspect and adjust switch as above whenever it has to be removed for service.

9. Check inhibitor switch for operation:

Starter should be brought into operation only when selector lever is in "P" and "N" positions (it should not be started when lever is in "D," "2," "1" and "R" positions).

Back-up lamp should also light when selector lever is placed in "R" position.

10. Check level of oil in transmission. For detailed procedure, see page AT-49.

11. Move selector lever through all positions to be sure that transmission operates correctly.

With hand brake applied, rotate engine at idling. Without disturbing the above setting, move selector lever through "N" to "D," to "2," to "1" and to "R." A slight shock should be felt by hand gripping selector each time transmission is shifted.

Note: See page AT-50 for checking engine idling.

12. Check to be sure that line pressure is correct. To do this, refer to relative topic under "Testing line pressure" on page AT-53.

13. Perform stall test as per the instructions on page AT-51.

AUTOMATIC TRANSMISSION

TRANSMISSION CONTROL LINKAGE

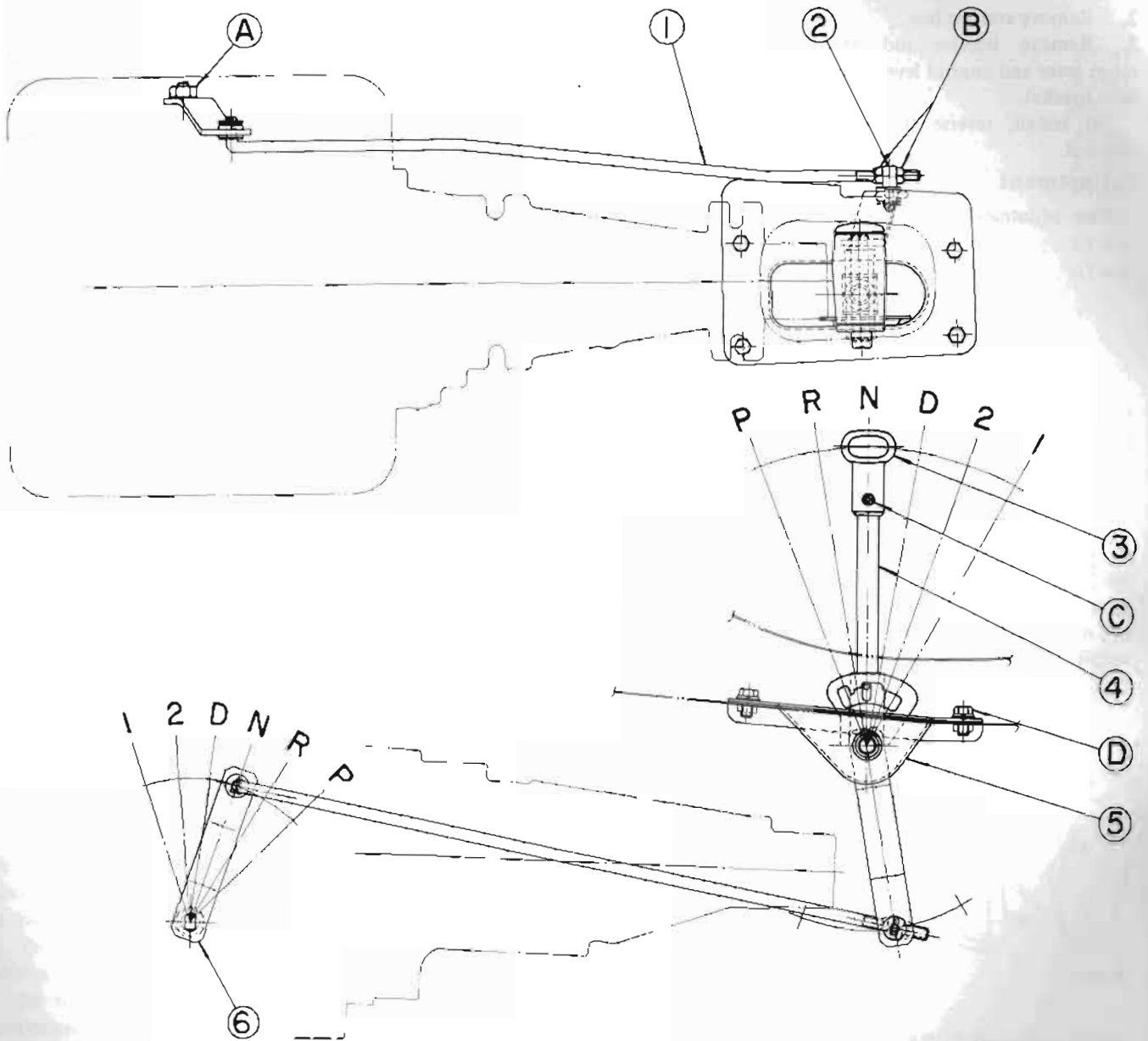

- 1 Selector rod
- 2 Joint trunnion
- 3 Control lever knob
- 4 Control lever assembly
- 5 Control lever bracket
- 6 Selector range lever

Tightening torque (T)
of bolts and nuts kg-m (ft-lb)

- (A) = 3.0 to 4.0 (22 to 29)
- (B) = 0.8 to 1.1 (5.8 to 7.9)
- (C) = 0.2 to 0.25 (1.4 to 1.8)
- (D) = 0.8 to 1.1 (5.8 to 7.9)

Fig. AT-51 Control linkage system

Removal and installation

1. Disconnect control knob from control lever by removing two(2) screws.
2. Remove console box.
3. Remove selector rod, selector range lever and control lever assembly with bracket.

To install, reverse the order of removal.

Adjustment

The adjustment of linkage is as

important as "Inspection of oil level" for the automatic transmission.

Therefore, great care should be exercised because defective adjustment will result in the breakdown of the transmission.

1. Loosen adjust nuts (B). See Figure AT-51.
2. Set control lever (4) and selector range lever (6) at "N" position. See Figure AT-51.

3. Set selector rod (1) to trunnion (2) by turning in or out adjust nuts. See Figure AT-51.

After adjusting, make sure that control lever can be set in any position correctly and that selector lever operates properly without any binding.

If levers do not operate satisfactorily, readjust or replace parts as necessary.

AUTOMATIC TRANSMISSION

MAJOR REPAIR OPERATION

CONTENTS

SERVICE NOTICE FOR DISASSEMBLY AND ASSEMBLY	AT-37	COMPONENT PARTS	AT-41
TORQUE CONVERTER	AT-37	Front clutch	AT-41
Inspection	AT-37	Rear clutch	AT-42
TRANSMISSION	AT-37	Low & reverse brake	AT-43
Disassembly	AT-37	Servo piston	AT-43
Inspection	AT-39	Governor	AT-44
Assembly	AT-39	Oil pump	AT-44
		Planetary carrier	AT-45
		Control valve	AT-45

SERVICE NOTICE FOR DISASSEMBLY AND ASSEMBLY

1. It is desirable that the repair operations are carried out in the dust-proof room.
2. Due to the differences of the engine capacities, the specifications of component parts for each model's transmission may be different. However, they do have common adjustments and repair as well as cleaning and inspection procedures, outlined hereinafter.
3. During the repair operations, refer to the "Service Data and Specifications" section for the correct parts for the applicable model transmission.
4. Before removing any of subassemblies, thoroughly clean the outside of the transmission to prevent dirt from entering the mechanical parts.
5. Do not use a waste rag. Use a nylon waste or paper waste.
6. After disassembling, wash all disassembled parts clean, and examine them to see if there are any worn, damaged or defective parts, and how they are affected. Refer to Service Data for the extent of damage that justifies replacement.
7. Packings, seals and similar parts once disassembled should be replaced with new ones as a rule.

TORQUE CONVERTER

The torque converter is a welded construction and can not be disassembled.

Inspection

1. Check torque converter for any sign of damage, bending, oil leak or deformation. If necessary, replace.
2. Remove rust from pilots and bosses completely.

If torque converter oil is fouled or contaminated due to burnt clutch, flush the torque converter as follows:

- (1) Drain oil in torque converter.
- (2) Pour none-lead gasoline or kerosene into torque converter [approximately 0.5 liter (1 1/8 U.S.pt., 7/8 Imper.pt.)].
- (3) Blow air into torque converter and flush and drain out gasoline.
- (4) Fill torque converter oil into torque converter [approximately 0.5 liter (1 1/8 U.S.pt., 7/8 Imper.pt.)].
- (5) Again blow air into torque converter, and drain torque converter oil.

TRANSMISSION

Disassembly

1. Drain oil from the end of rear extension. Mount transmission on Transmission Case Stand ST07860000 or ST07870000. Remove oil pan. See Figure AT-52.

2. Remove bolts securing converter housing to transmission case. Remove torque converter.
3. Remove speedometer pinion sleeve bolt. Withdraw pinion.
4. Turn off by hand downshift solenoid and vacuum diaphragm. Do not leave diaphragm rod at this stage of disassembly. Rod is assembled in top of vacuum diaphragm. See Figure AT-53.

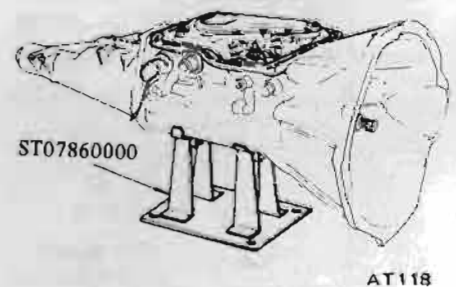

Fig. AT-52 Removing oil pan

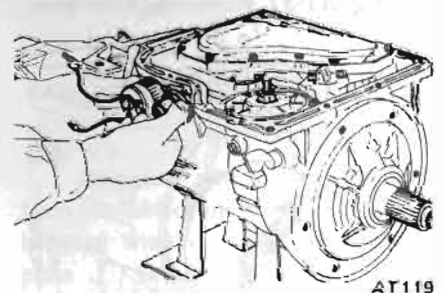
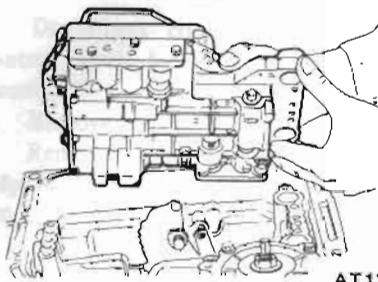

Fig. AT-53 Downshift solenoid and vacuum diaphragm

CHASSIS



AT120

Fig. AT-54 Removing valve body

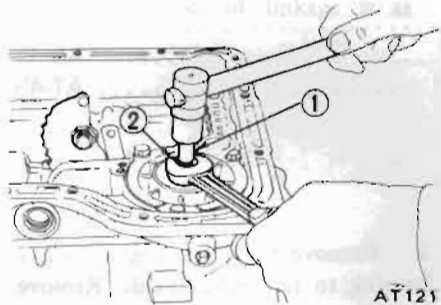

AT121

Fig. AT-55 Loosening band servo

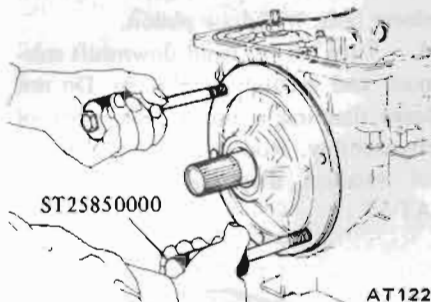

ST25850000

AT122

Fig. AT-56 Removing oil pump

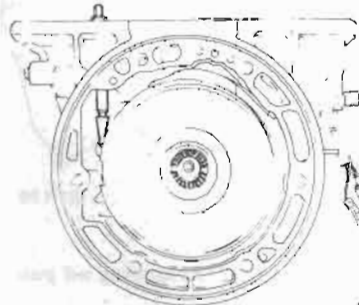

AT123

Fig. AT-57 Removing band strut

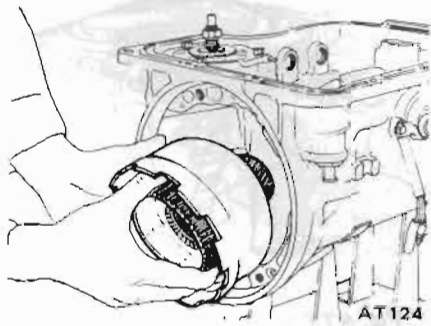

AT124

Fig. AT-58 Removing connecting shell

5. Remove bolts which hold valve body to transmission case. See Figure AT-54.

6. Loosen lock nut ② on piston stem ① as shown in Figure AT-55. Then tighten piston stem in order to prevent to fall front clutch drum down when oil pump is withdrawn.

7. Pull out input shaft.

8. Withdraw oil pump using Sliding Hammer ST25850000. Exercise care not to allow front clutch to come out of position and drop onto floor. See Figure AT-56.

9. Remove band strut. This can be done by loosening piston stem further. See Figure AT-57.

10. Remove brake band, front clutch and rear clutch as an assembled unit.

11. Remove connecting shell, rear clutch hub and front planetary carrier as a unit. See Figure AT-58.

12. With the aid of Snap Ring Plier HT69860000, pry snap ring off output shaft. See Figure AT-59.

13. Remove connecting drum and inner gear of rear planetary carrier as an assembly. See Figure AT-60.

14. Remove snap rings and then remove rear planetary carrier, internal gear, connecting drum, one-way clutch outer race and one-way clutch in this written order.

15. Remove rear extension loosening securing bolts. See Figure AT-61.

16. Pull out output shaft; remove oil distributor ② together with governor valve ①. See Figure AT-62.

17. Pry off snap ring using a pair of pliers. Remove retaining plate, drive plate, driven plate and dish plate in this written order. See Figure AT-63.

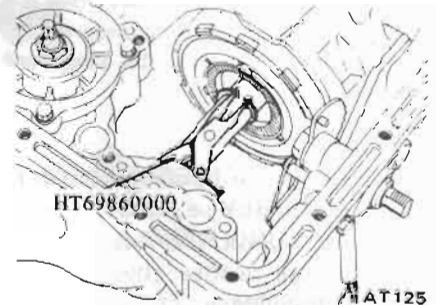

AT125

Fig. AT-59 Removing snap ring

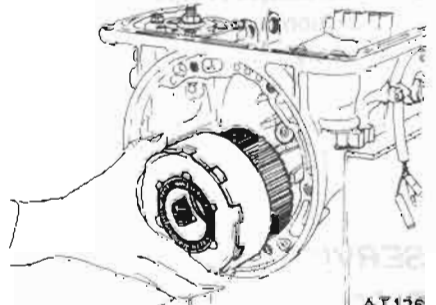

AT126

Fig. AT-60 Removing connecting drum

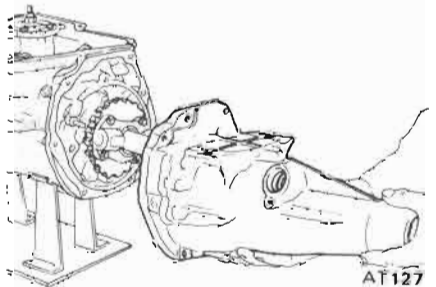

AT127

Fig. AT-61 Removing rear extension

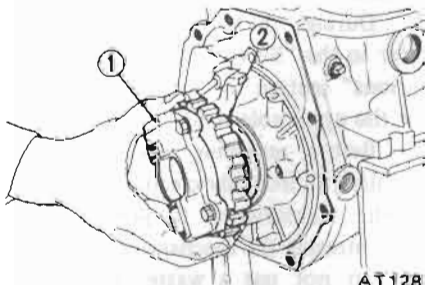

AT128

Fig. AT-62 Removing governor and oil distributor

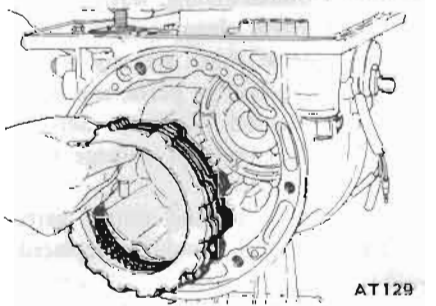

AT129

Fig. AT-63 Removing drive and driven plates

AUTOMATIC TRANSMISSION

18. Reaching through back side of transmission case, remove hex-head slotted bolts as shown in Figure AT-64. To do this, use Hex-head Extension ST25570000. One-way clutch inner race, thrust washer, piston return spring and thrust spring ring can now be removed.

19. Blow out low and reverse brake piston by directing a jet of air into hole in cylinder. See Figure AT-65.

20. Remove band servo loosening attaching bolts.

Note: If difficulty is encountered in removing retainer, direct a jet of air toward release side as shown in Figure AT-66.

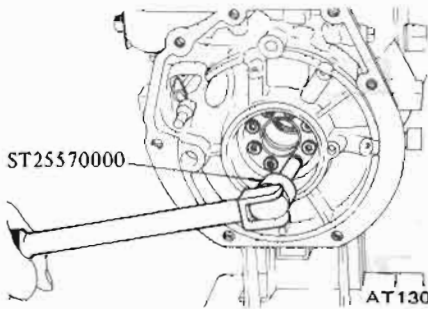

Fig. AT-64 Removing hex-head slotted bolt

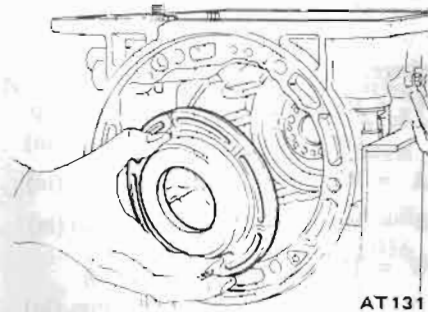

Fig. AT-65 Removing piston

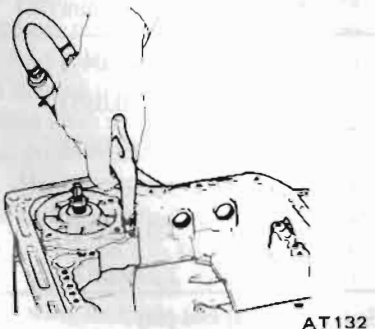
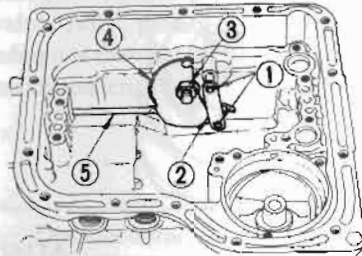

Fig. AT-66 Removing band servo

21. Pry snap rings ① from both ends of parking brake lever ② and remove the lever. Loosen off manual shaft lock nut ③ and remove manual shaft plate ④ and parking rod ⑤. See Figure AT-67.



AT133

Fig. AT-67 Removing manual plate

22. Remove inhibitor switch and manual shaft loosening two securing bolts.

Inspection

Torque converter housing, transmission case and rear extension

1. Check for damage or cracking; if necessary, replace.
2. Check for dent or score mark on their mating surfaces. Repair as necessary.
3. Check for score mark or sign of burning on extension bushing; if necessary, replace.

Gaskets and O-ring

1. Always use new gaskets when the units are to be disassembled.
2. Check O-rings for burrs or cracking. If necessary, replace with new rings.

Oil distributor

1. Check for sign of wear on seal ring and ring groove, replacing with new ones if found worn too badly beyond use.
2. Test if clearance between seal ring and ring groove is correct. If out of specifications, replace whichever worn excessively beyond limits. Correct clearance is from 0.04 to 0.16 mm (0.0016 to 0.0063 in). See Figure AT-68.

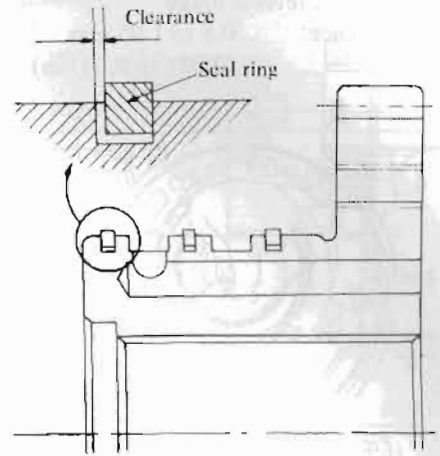

AT134

Fig. AT-68 Measuring seal ring to ring groove clearance

Assembly

Assembly is reverse order of disassembly. However, observe the following assembly notes.

1. After installing piston of low and reverse brake, assemble thrust spring ring, return spring, thrust washer and one-way clutch inner race. Torque hex-head slotted bolt to 1.3 to 1.8 kg-m (9.4 to 13 ft-lb), using Hex-head Extension ST25570000, Torque Wrench GG93010000 and Socket Extension ST25512001. See Figure AT-69.

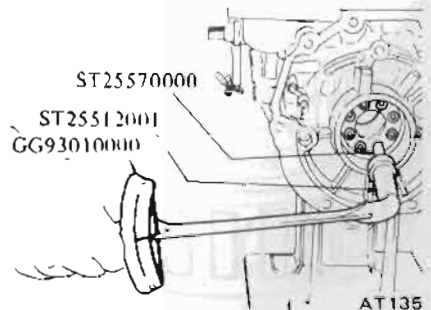

Fig. AT-69 Installing one-way clutch inner race

2. After low and reverse brake has been assembled, measure the clearance between snap ring ① and retaining plate ②. Select proper thickness of retaining plate that will give correct ring to plate clearance. See Figure AT-70.

- Low and reverse brake clearance: 0.8 to 1.05 mm (0.031 to 0.041 in)

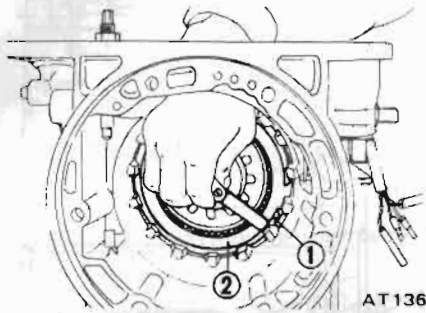

Fig. AT-70 Measuring ring to plate clearance

Available retaining plate

No.	Thickness mm (in)
1	7.8 (0.307)
2	8.0 (0.315)
3	8.2 (0.323)
4	8.4 (0.331)
5	8.6 (0.339)
6	8.8 (0.346)

As to inspection procedure for low and reverse brake, see page AT-43.

3. Install one-way clutch so that the arrow mark "→" is toward front of vehicle. It should be free to rotate only in clockwise direction. See Figure AT-71.



AT137

Fig. AT-71 One-way clutch

4. After installing rear extension, torque attaching bolts to 2.0 to 2.5 kg-m (14 to 18 ft-lb). Place manual lever in "P" range and check to be sure that rear output shaft is securely blocked.

5. Tighten servo retainer temporarily at this stage of assembly.

6. Place rear clutch assembly with needle bearing on front assembly.
7. Install rear clutch hub and front planetary carrier in the manner as shown in Figure AT-72.

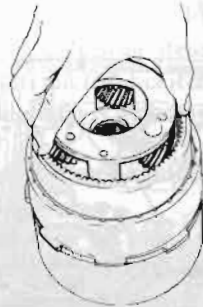

AT142

Fig. AT-72 Installing planetary carrier

8. Assemble connecting shell and other parts up to front clutch in reverse order of disassembly.



AT143

Fig. AT-73 Installing connecting shell

9. Adjust total end play and front end play as follows:

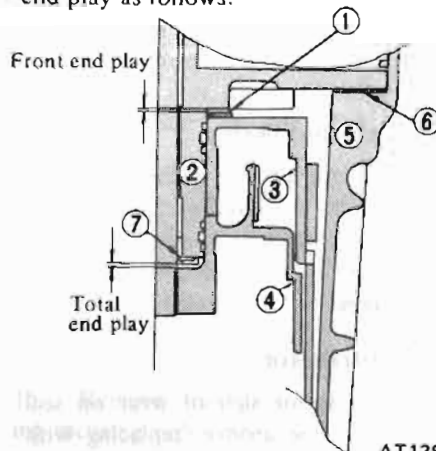

AT138

- | | |
|------------------------------|-------------------------------|
| 1 Front clutch thrust washer | 5 Transmission case |
| 2 Oil pump | 6 Oil pump gasket |
| 3 Front clutch | 7 Oil pump cover bearing race |
| 4 Rear clutch | |

Fig. AT-74 End play

- (1) Measure the distance "A" and "C" by vernier calipers as shown in Figure AT-75.

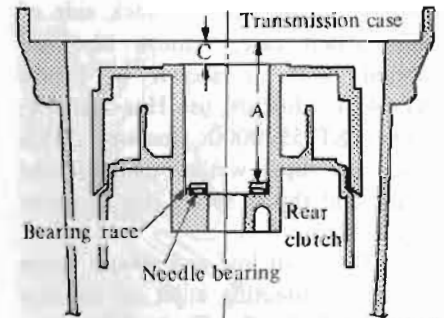

AT139

Fig. AT-75 Measuring the distance "A" and "C"

- (2) Measure the distance "B" and "D" of oil pump cover as shown in Figure AT-76.

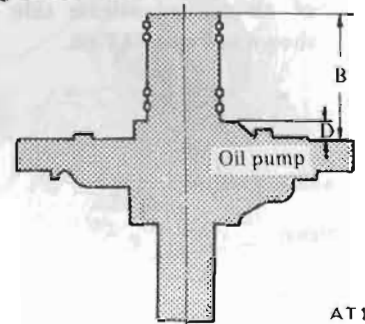

AT140

Fig. AT-76 Measuring the distance "B" and "D"

Adjustment of total end play

Select oil pump cover bearing race by calculating the following formula:

$$T_T = A - B + W$$

where,

T_T = Required thickness of oil pump cover bearing race mm (in)

A = Measured distance A mm (in)

B = Measured distance B mm (in)

W = Thickness of bearing race temporarily inserted mm (in)

Available oil pump cover bearing race

No.	Thickness mm (in)
1	1.2 (0.047)
2	1.4 (0.055)
3	1.6 (0.063)
4	1.8 (0.071)
5	2.0 (0.079)
6	2.2 (0.087)

Specified total end play:

0.25 to 0.50 mm

(0.009 to 0.020 in)

AUTOMATIC TRANSMISSION

Adjustment of front end play

Select front clutch thrust washer by calculating the following formula:

$$T_F = C - D - 0.2 \text{ (mm)}$$

where,

T_F = Required thickness of front clutch thrust washer mm (in)

C = Measured distance C mm (in)

D = Measured distance D mm (in)

12. After inhibitor switch is installed, check to be sure that it operates properly in each range. For detailed procedure, refer to covering topic on page AT-51.

13. Check the length "L" between case end to rod end of vacuum throttle valve fully pushed in. Then select adequate diaphragm rod corresponding measured length. See Figure AT-77.

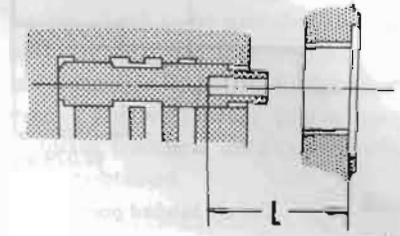

AT145

Fig. AT-77 Measuring the distance "L"

Available diaphragm rod

Distance measured "L" mm (in)	Diaphragm rod length mm (in)
Under 25.55 (1.006)	29.0 (1.142)
25.65 to 26.05 (1.010 to 1.026)	29.5 (1.161)
26.15 to 26.55 (1.030 to 1.045)	30.0 (1.181)
26.65 to 27.05 (1.049 to 1.065)	30.5 (1.201)
Over 27.15 (1.069)	31.0 (1.220)

Available front clutch thrust washer

No.	Thickness mm (in)
1	1.5 (0.059)
2	1.7 (0.067)
3	1.9 (0.075)
4	2.1 (0.083)
5	2.3 (0.091)
6	2.5 (0.098)
7	2.7 (0.106)

Specified front end play.

0.5 to 0.8 mm
(0.020 to 0.031 in)

Notes: a. Correct thickness of bearing race and thrust washer is always the one which is nearest the calculated one.

b. Installed thickness of oil pump gasket is 0.4 mm (0.016 in).

10. Check to be sure that brake servo piston moves freely. For detailed procedure, refer to covering topic on page AT-43. Use care to prevent piston from coming out of place during testing since servo retainer is not tightened at this point of assembly.

11. Make sure that brake band strut is correctly installed. Torque piston stem to 1.2 to 1.5 kg-m (8.7 to 11 ft-lb); Back off two full turns and secure with lock nut. Lock nut tightening torque is 1.5 to 4.0 kg-m (11 to 29 ft-lb).

COMPONENT PARTS

The transmission consists of many small parts that are quite alike in construction yet machined to very close tolerances. When disassembling parts, be sure to place them in order in a part rack so they can be restored in the unit in their proper positions. It is also very important to perform functional test whenever it is designated.

Front clutch

Disassembly

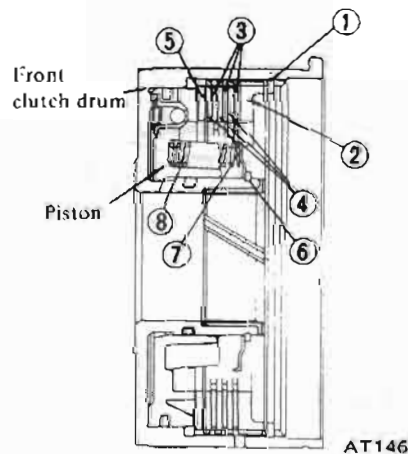

AT146

- | | |
|-------------------|-------------------|
| 1 Snap ring | 5 Dished plate |
| 2 Retaining plate | 6 Snap ring |
| 3 Drive plate | 7 Spring retainer |
| 4 Driven plate | 8 Coil spring |

Fig. AT-78 Sectional view of front clutch

1. Pry off snap ring ① with a suitable screwdriver or a pair of pliers. Remove a retaining plate ②, drive plate ③, driven plate ④ and dish plate ⑤ in the order listed as shown in Figure AT-78.

2. Compress clutch springs, using Clutch Spring Compressor ST25420000 (or ST2542001). Remove snap ring ⑥ from spring retainer, using Snap Ring Remover ST25320001. See Figure AT-79.

Note: When Clutch Spring Compressor ST25420000 is to be used, cut the toe-tips of three legs by a grinding wheel. See Figure AT-80.

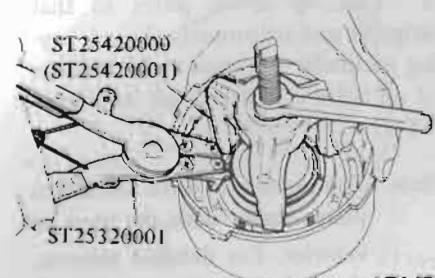

AT147

Fig. AT-79 Removing snap ring

CHASSIS

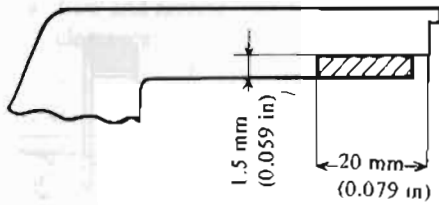

AT148 Cut off hatched portion

Fig. AT-80 Modifying of coil spring compressor

3. Take out spring retainer ⑦ and spring ⑧. See Figure AT-78.
4. Blow out piston by directing a jet of air into hole in clutch drum. See Figure AT-81.

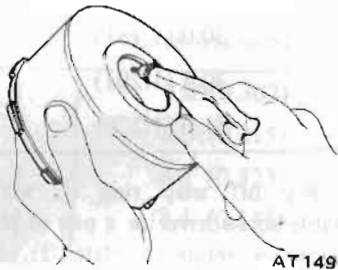

Fig. AT-81 Blowing out piston

Inspection

1. Check for sign of wear or damage to clutch drive plate facing. If found worn or damaged excessively, discard. See Service Data for limits.
2. Check for wear on snap ring and for weakened or broken coil spring.

If necessary, replace with new ones.

Spring retainer should also be inspected for warpage.

Assembly

1. Assembly is reverse order of disassembly. Dip all parts in clean automatic transmission fluid before they can be installed.
2. Line up driven plates so that stripped arcs are properly aligned, paying particular attention to the location of oil holes in clutch drum. See Figure AT-82.

Note: The number of drive and driven plates varies with the type of vehicles. For detailed information, also see Service Data & Specifications.

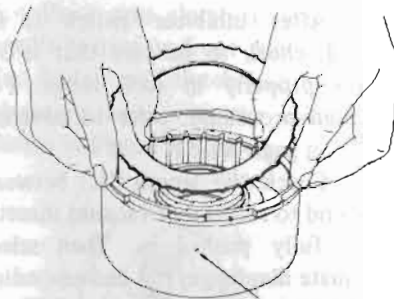

AT150 Lubrication hole

Fig. AT-82 Inserting clutch plate

3. After clutch is assembled, make sure that clearance between snap ring ① and retaining plate ② is held within specified limits. If necessary, try with other plates having different thickness until correct clearance is obtained. See Figure AT-83.

Specified clearance:
1.6 to 1.8 mm
(0.063 to 0.071 in)

Available retaining plate

No.	Thickness mm (in)
1	10.6 (0.417)
2	10.8 (0.425)
3	11.0 (0.433)
4	11.2 (0.441)
5	11.4 (0.449)
6	11.6 (0.457)

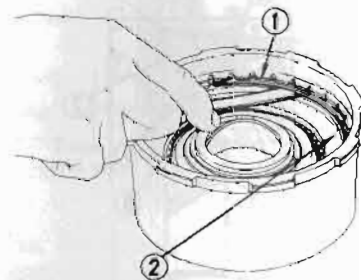

AT151

Fig. AT-83 Measuring ring to plate clearance

4. Testing front clutch
With front clutch assembled on oil pump cover, direct a jet of air into hole in clutch drum. See Figure AT-84.

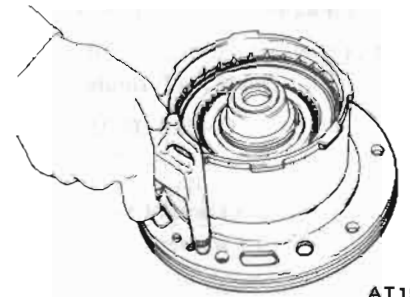

AT152

Fig. AT-84 Testing front clutch

Rear clutch

Disassembly

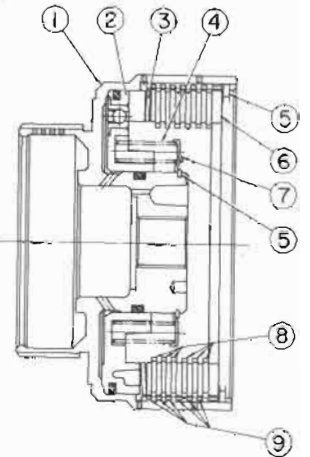

AT270

- | | |
|--------------------|-------------------|
| 1 Rear clutch drum | 6 Retaining plate |
| 2 Piston | 7 Spring retainer |
| 3 Dished plate | 8 Drive plate |
| 4 Coil spring | 9 Driven plate |
| 5 Snap ring | |

Fig. AT-85 Sectional view of rear clutch

1. Take out snap ring ③, retaining plate ④, drive plate ⑤, driven plate ⑥ and dished plate ⑦. Same technique can be applied as in disassembling front clutch. See Figure AT-85.
2. Remove snap ring from coil spring retainer. See Figure AT-86.

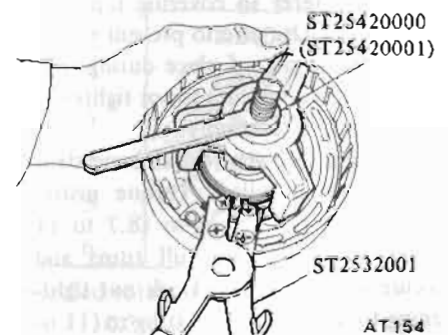

AT154

Fig. AT-86 Removing snap ring

AUTOMATIC TRANSMISSION

- Blow out piston by directing a jet of air into hole in clutch drum. See Figure AT-87.

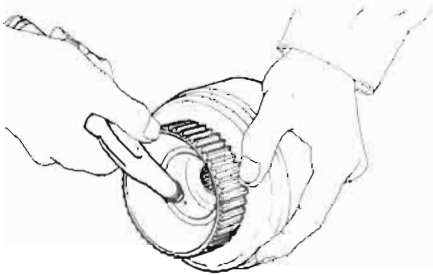

AT155

Fig. AT-87 Blowing out piston

Inspection

Refer to covering topic under "Front Clutch."

Assembly

Assembly is reverse order of disassembly. Dip all parts in clean automatic transmission fluid before assembling. Note that the number of drive and driven plates varies with types of vehicles. For details, refer to Service Data & Specifications.

- After rear clutch is assembled, check to be sure that clearance between snap ring ① and retaining plate ② is held within prescribed tolerances. See Figure AT-88.

Specified clearance:

1.0 to 1.5 mm
(0.039 to 0.059 in)

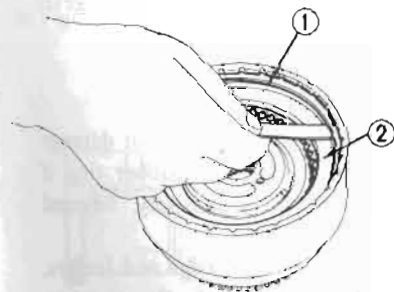

AT156

Fig. AT-88 Measuring ring to plate clearance

2. Testing rear clutch

Install rear clutch on oil pump cover.

Blow air under pressure into oil hole to listen for definite clutch operation as shown in Figure AT-89.

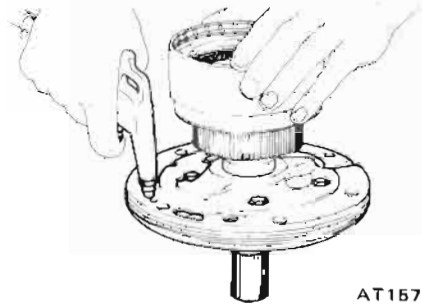

AT157

Fig. AT-89 Testing rear clutch

Low & reverse brake

Disassembly

- Follow steps as per instructed on page AT-38.
- Blow out piston by directing a jet of air into oil hole in clutch piston.

Inspection

- Check drive plate facing for wear or damage; if necessary, replace. Refer to Service Data & Specifications for limits.
- Test if piston return spring is not weakened. Discard if weakened too badly beyond use.
- Replace any defective parts with new ones.

Assembly

- After low & reverse piston is installed, assemble thrust spring ring, return spring, thrust washer and one-way clutch inner race. With the aid of Hex-head Extension ST25570000, tighten hex-head slotted bolt 1.3 to 1.8 kg-m (9.4 to 13 ft-lb)
- Enter dished plate, driven plate, drive plate and retaining plate into transmission case in this written order. Install snap ring to secure the installation.

Note: The number of drive and driven plates varies with types of vehicles. For detailed information, refer to Service Data & Specifications.

- Without disturbing the above setting, check to be sure that clearance between snap ring and retaining plate is held within specified limits. If necessary, try with other plates having different thickness until correct clearance is obtained.

Specified clearance:

0.80 to 1.05 mm
(0.031 to 0.041 in)

- Blow under pressure air into oil hole in low & reverse brake to listen for definite brake operation as shown in Figure AT-90.

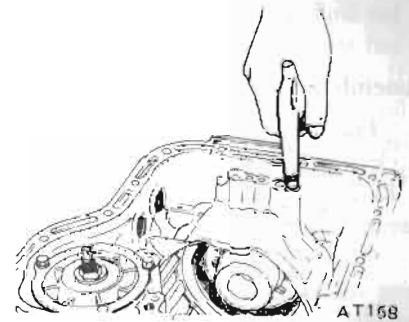

AT158

Fig. AT-90 Testing low & reverse brake

Servo piston

Disassembly

- Blow out piston by directing a jet of air into hole in release-side of piston.
- Remove servo piston return spring.

Inspection

Check piston for wear, damage or any other defects which might interfere with proper brake operation.

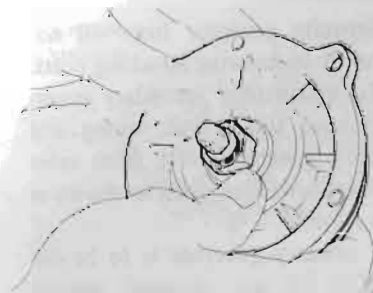

AT159

Fig. AT-91 Removing piston

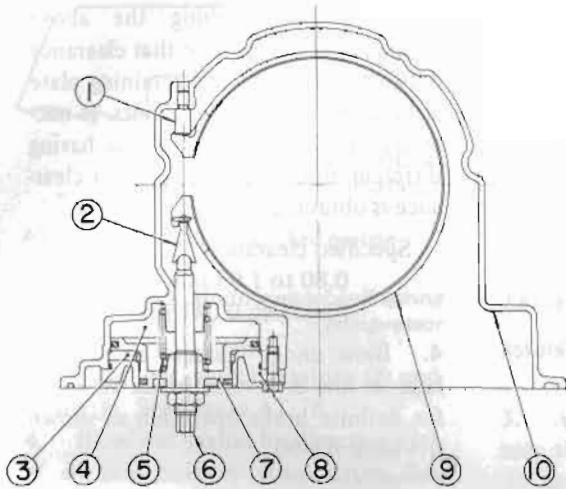

- 1 Anchor end pin
- 2 Band strut
- 3 Apply
- 4 Release
- 5 Return spring
- 6 Band servo piston stem
- 7 Band servo piston
- 8 Servo retainer
- 9 Brake band assembly
- 10 Transmission case

AT271

Fig. AT-92 Sectional view of servo piston

Assembly

1. Prior to assembling, dip all parts in clean automatic transmission fluid.

Reverse disassembly procedure to assemble brake.

2. Use extreme care to avoid damaging rubber ring when installing seal lace.

3. Blow under pressure air from apply-side of piston to listen for definite piston operation as shown in Figure AT-93.

4. With apply-side of piston plugged with thumb, blow air under pressure into cylinder from release-side as shown in Figure AT-94. If retainer is raised a little, it is an indication that attaching bolts are loosened, calling for retightening.

Governor

Disassembly

1. Separate governor from oil distributor by unscrewing attaching bolts.

2. To disassemble secondary governor, remove spring seat, spring and secondary governor valve from valve body in this written order as shown in Figure AT-95.

3. If primary governor is to be disassembled for any purpose, remove spring seat, primary governor valve, spring and spring seat.

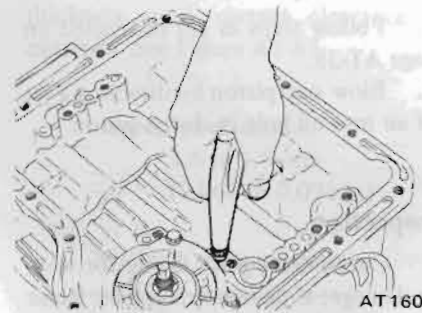

Fig. AT-93 Testing piston (Apply side)

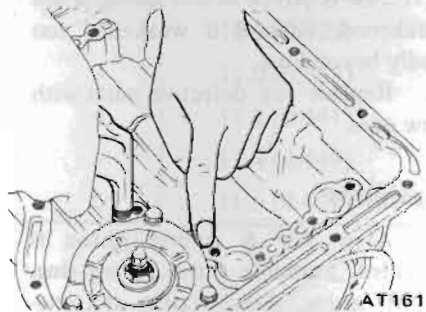

Fig. AT-94 Testing piston (Release side)

Inspection

1. Check valve for defective condition. Replace spring if found weakened too badly beyond use. Defective piston should also be replaced with a new one.

2. Examine if primary governor slides freely without binding.

3. To determine if secondary governor is in good condition, blow air under light pressure into hole at "A" to listen for noise like a model plane.

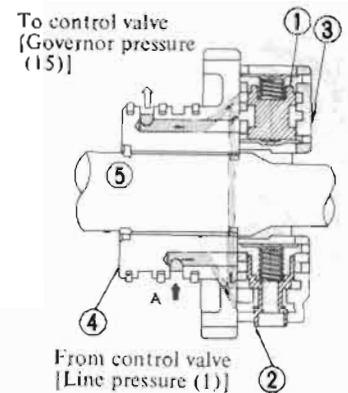

- 1 Primary governor
- 2 Secondary governor
- 3 Governor valve body
- 4 Oil distributor
- 5 Output shaft

AT090

Fig. AT-95 Testing secondary governor

Assembly

Reverse disassembly procedure to assemble governor.

Note: Do not confuse primary governor with secondary governor. After installation, check to be sure that spring is not deflected.

Oil pump

Disassembly

1. Free pump cover from pump housing by removing attaching bolts.
2. Take out inner and outer gears from pump housing.

Inspection

1. Inspect gears for wear or damage to gear teeth. Replace rubber ring if found damaged excessively beyond use.

2. Using a straight edge and feelers, measure pump and gear clearances as follows:

- Clearance between inner (or outer) gear and pump cover. See Figure AT-96.

Standard clearance:

0.02 to 0.04 mm
(0.0008 to 0.0016 in)

[Replace if going over 0.08 mm (0.0031 in).]

AUTOMATIC TRANSMISSION

- Clearance between seal ring and ring groove. See Figure AT-97.
Standard clearance:
0.04 to 0.16 mm
(0.0016 to 0.0063 in)

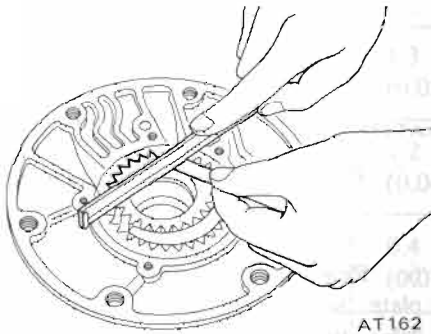

Fig. AT-96 Measuring clearance

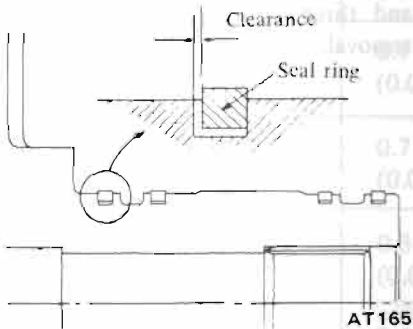
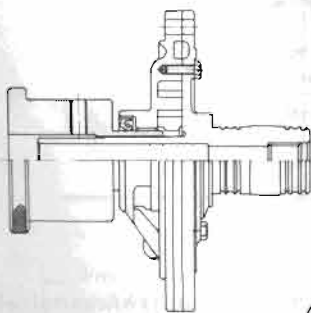

Fig. AT-97 Measuring clearance

Assembly

1. Set up pump housing and inner and outer pump gears on it.
2. With the aid of Oil Pump Assembling Gauge ST25580000, install pump cover to pump housing as shown in Figure AT-98.



AT166

Fig. AT-98 Centering oil pump

3. Temporarily tighten pump securing bolts.
4. Set the runout of oil pump cover within 0.07 mm (0.0028 in) total indicator reading. See Figure AT-99.

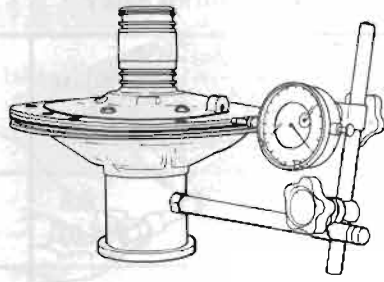

AT264

Fig. AT-99 Measuring runout

5. Tighten pump securing bolts to specified torque 0.6 to 0.8 kg-m (4.3 to 5.8 ft-lb).

Note: Be sure to align converter housing securing bolt holes.

6. Again, check the runout of oil pump cover.

Note: When former Oil Pump Assembling Gauge is to be used, make a screw hole in side of it.

Planetary carrier

The planetary carrier cannot be divided into its individual components. If any part or component is defective, replace the carrier as a unit.

Inspection

Check with a feeler clearance between pinion washer and planetary carrier. See Figure AT-100.

- Standard clearance:
0.20 to 0.70 mm
(0.008 to 0.028 in)

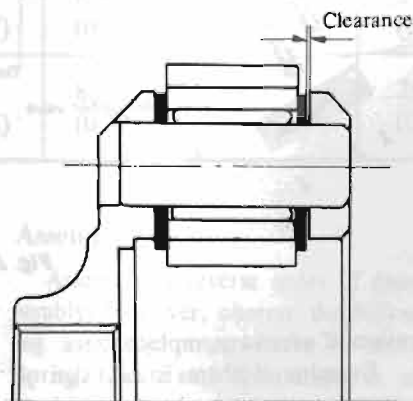

AT167

Fig. AT-100 Measuring pinion washer to carrier clearance

[Replace if going over 0.80 mm (0.031 in).]

Control valve

The control valve assembly consists of many precision parts and requires extreme care when it has to be removed and serviced. It is good practice to place parts in a part rack so that they can be restored in valve body in their proper positions. Added care should also be exercised to prevent springs and other small parts from being scattered and lost.

Before assembly, dip all parts in clean automatic transmission fluid and check to be certain that they are free of lint and other minute particles. If clutch or band is burnt or if oil becomes fouled, the control valve assembly should be disassembled and flushed.

Disassembly

1. Remove bolts and nuts which retain oil strainer. Bolts may be removed with a screwdriver, but it is recommended to use Hexagon Wrench HT61000800 and Spinner Handle HT62350000. See Figure AT-101.
2. Remove attaching bolts. With bolts removed, lower valve body, separate plate and upper valve body are free for removal. See Figure AT-102.

Note: Do not allow orifice check valve and valve spring in lower valve body from being scattered and lost when removing separate plate.

HT61000800
HT62350000

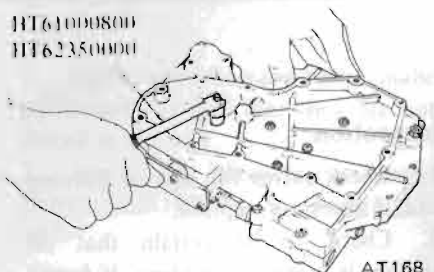

AT168

Fig. AT-101 Removing valve bo

CHASSIS

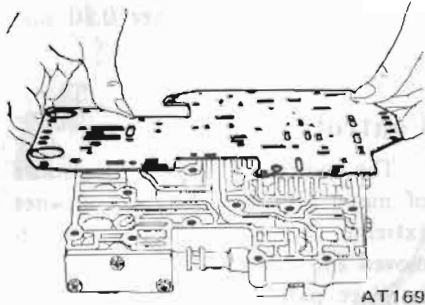

Fig. AT-102 Removing separate plate

3. Pull out manual valve as shown in Figure AT-103.

4. Remove side plate. Take out "1st-2nd" shift valve, "2nd-3rd" shift valve, pressure modifier valve and three valve springs. See Figure AT-104.

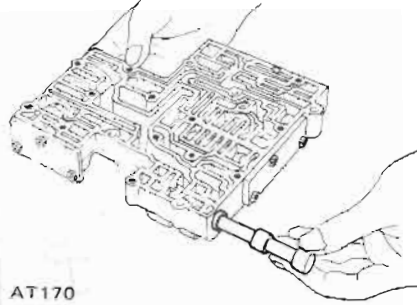

Fig. AT-103 Removing manual valve

Note: Do not work it off with screwdrivers to avoid damaging machine screws.

5. Remove side plate; pull out pressure regulator valve, second lock valve, pressure regulator plug and two valve springs.

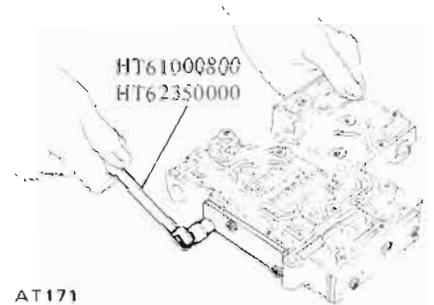

Fig. AT-104 Removing side plate

6. Remove side plate. With side plate removed, solenoid downshift valve; throttle back-up valve, vacuum throttle valve, "2nd-3rd" timing valve and three valve springs are free for removal.

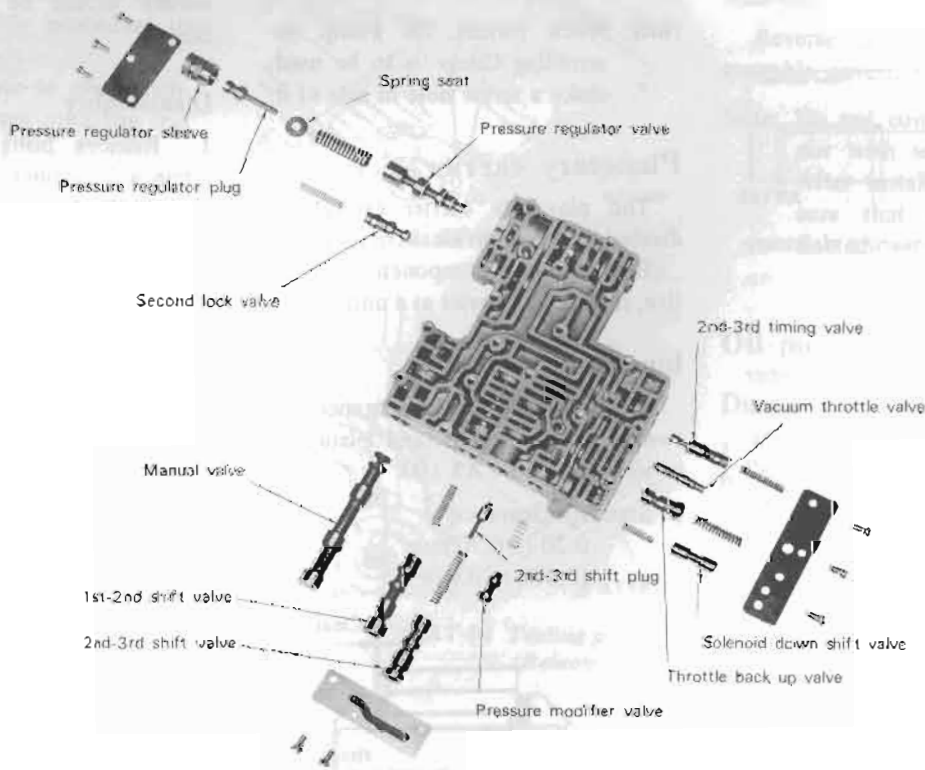

Fig. AT-105 Components parts of control valve

Inspection

1. Check valves for sign of burning and, if necessary, replace.
2. Check to be certain that oil strainer is in good condition. If found damaged in any manner, discard.
3. Test valve springs for weakened

tension; if necessary, replace.

4. Examine if there is any sign of damage or score marks on separate plate. If left unheeded, oil will bypass correct oil passages causing many types of abnormalities in the system.

5. Check oil passages in valve body for sign of damage and other conditions which might interfere with proper valve operation.
6. Check bolts for stripped threads. Replace as required.

AUTOMATIC TRANSMISSION

Valve spring chart

Valve spring	Wire dia. mm (in)	Mean coil dia. mm (in)	No. of active coil	Free length mm (in)	Installed	
					Length mm (in)	Load kg (lb)
Manual detent	1.3 (0.0512)	6.0 (0.2362)	15.0	32.4 (1.276)	26.5 (1.043)	5.5 (12)
Pressure regulator	1.2 (0.0472)	10.5 (0.4134)	13.0	43.0 (1.693)	23.5 (0.925)	2.8 (6.2)
Pressure modifier	0.4 (0.0157)	8.0 (0.3150)	5.0	18.5 (0.728)	9.0 (0.3543)	0.1 (0.2)
1st - 2nd shift	0.6 (0.0236)	6.0 (0.2362)	16.0	32.0 (1.260)	16.0 (0.630)	0.625 (1.4)
2nd - 3rd shift	0.7 (0.0276)	6.2 (0.2441)	18.0	41.0 (1.614)	17.0 (0.669)	1.40 (3.1)
2nd - 3rd timing	0.7 (0.0276)	5.5 (0.2165)	15.0	32.5 (1.280)	27.0 (1.063)	0.55 (1.2)
Throttle back-up	0.8 (0.0315)	6.5 (0.2559)	14.0	36.0 (1.417)	18.8 (0.740)	1.92 (4.2)
Solenoid downshift	0.55 (0.0217)	5.0 (0.1969)	12.0	22.0 (0.866)	12.5 (0.492)	0.60 (1.3)
Second lock	0.55 (0.0217)	5.0 (0.1969)	16.0	33.5 (1.319)	21.0 (0.827)	0.60 (1.3)
Throttle relief	0.9 (0.0354)	5.6 (0.2205)	14.0	26.8 (1.055)	19.0 (0.748)	2.19 (4.8)
Orifice check	0.2 (0.0078)	4.8 (0.1890)	15.0	21.5 (0.846)	11.5 (0.453)	0.01 (0.02)
Primary governor	0.45 (0.0177)	8.3 (0.3268)	5.0	21.8 (0.858)	7.5 (0.2953)	0.215 (0.5)
Secondary governor	0.7 (0.0276)	8.5 (0.3346)	5.5	25.1 (0.988)	10.5 (0.413)	1.10 (2.4)

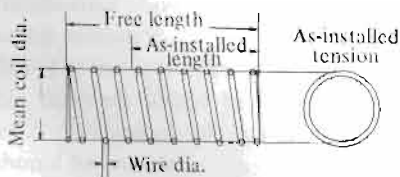

AT172

Fig. AT-106 Valve spring

Assembly

Assembly is reverse order of disassembly. However, observe the following assembly notes. Refer to Valve Spring Chart and illustration in assembling valve springs. Dip all parts in clean automatic transmission fluid before assembly. Tighten parts to specifications whenever designated.

1. Slide valve into valve body and be particularly careful that they are not forced in any way.

2. Install side plates using Torque Driver ST25160000. See Figure AT-107.

Tightening torque:

0.25 to 0.35 kg-m
(1.9 to 2.5 ft-lb)

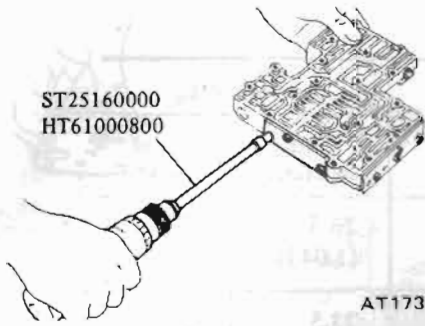

Fig. AT-107 Installing side plate

Note: Install check valve and relief spring so that they are properly positioned in valve body.



Fig. AT-108 Installing valve body

3. Install orifice check valve, valve spring, throttle relief valve spring and steel ball in valve body.

4. Install upper and lower valves. See Figure AT-108.

Tightening torque:
0.25 to 0.35 kg-m
(1.8 to 2.5 ft-lb)

Reamer bolt tightening torque:
0.5 to 0.7 kg-m
(3.6 to 5.1 ft-lb)

5. Install oil strainer.

Tightening torque:
0.25 to 0.35 kg-m
(1.8 to 2.5 ft-lb)

TROUBLE DIAGNOSES AND ADJUSTMENT

CONTENTS

INSPECTION AND ADJUSTMENT BEFORE TROUBLE DIAGNOSIS	AT-49	ROAD TEST	AT-52
Testing instrument for inspection	AT-49	Car speed at gear shift	AT-52
Checking oil level	AT-49	Checking speed changing condition	AT-53
Inspection and repair of oil leakage	AT-50	Checking items during speed change	AT-53
Checking engine idling rpm	AT-50	Shift schedule	AT-53
Checking and adjusting kick-down switch and downshift solenoid	AT-50	LINE PRESSURE TEST	AT-53
Inspection and adjustment of manual linkage	AT-51	Line pressure (governor feed pressure)	AT-53
Checking and adjusting inhibitor switch	AT-51	Judgement in measuring line pressure	AT-54
STALL TEST	AT-51	TROUBLE-SHOOTING CHART	AT-54
Stall test procedures	AT-51	Inspecting items	AT-54
Judgement	AT-52	Trouble-shooting chart for 3N71B Automatic Transmission	AT-55
		Trouble-shooting guide for 3N71B Automatic Transmission	AT-58

As the troubles on the automatic transmission can be mostly repaired by doing simple adjustment, so do not disassemble immediately if the automatic transmission is in trouble.

Firstly inspect and adjust the automatic transmission with mounting on vehicle by observing the trouble-shooting chart.

If the trouble could not be solved by this procedure, then remove and disassemble the automatic transmission. It is advisable to check, overhaul and repair each point in the order itemized in the "trouble-shooting chart."

1. In the "trouble-shooting chart" the diagnosis items are arranged in the order from easy to difficult and therefore please follow these items. The transmission should not be removed, unless necessary.
2. The test and adjustment for trouble diagnosis should be made on the basis of standard values and the data should be recorded.

INSPECTION AND ADJUSTMENT BEFORE TROUBLE DIAGNOSIS

Testing instrument for inspection

1. Engine tachometer
2. Vacuum gauge
3. Oil pressure gauge

It is convenient to install these instruments in a way that allows measurements to be made from the driver's seat.

Checking oil level

In checking the automatic transmission the oil level and the condition of oil around the oil level gauge should be examined every 5,000 km (3,000 miles). These steps are easy and effective in trouble-shooting as some change of oil conditions are linked with developed troubles in many cases.

For instance:

Lack of oil causes defective operation by making the clutches and brakes slip, developing severe wear.

The cause of this operation is that the oil pump has begun to suck air which caused oil foaming, thus rapidly deteriorating the oil quality and producing sludge and varnish.

Meanwhile, excessive oil is also bad as in the case of a lack of oil, because of oil foaming by being stirred up by the gears. Moreover, in high speed driving with excessive oil in the transmission the oil often blows out from the breather.

1. Measuring oil level

When checking the fluid level, start the engine and run it until normal operating temperatures [oil temperature: 50 to 80°C (122 to 176°F). Approximately ten-minute operation will elevate the temperature to this range.] and engine idling conditions are stabilized. Then, apply the brakes and move the transmission shift lever

through all drive positions and place the lever in park "P" position. In this inspection, the car must be placed on a level surface.

The amount of the oil varies with the temperature. As a rule the oil level must be measured after its temperature becomes sufficiently high.

(1) Fill the oil to the line "H." The difference of capacities between both "H" and "L" is approximately 0.4 liter (7/8 U.S.pt., 3/4 Imper.pt.) and, therefore, take care not to fill beyond the line "H."

(2) At the time of the above topping-up and changing of oil, care should be taken of to prevent mixing the oil with dust and water.

2. Inspecting oil condition

The condition of oil sticking to the level gauge indicates whether to overhaul and repair the transmission or look for the defective part.

If the oil has deteriorated into a varnish-like quality, it causes the control valve to stick. The blackened oil gives the proof of the burned clutch, brake band, etc. In these cases, the transmission must be replaced.

- Notes:
- In oil level checking, use special paper waste to handle the level gauge and take care not to let the scraps of paper and cloth stick to the gauge.
 - Insert the gauge fully and take it out quickly before splashing oil adheres to the gauge and then observe the level.
 - Use automatic transmission fluid having "DEXRON" identifications only in the 3N71B automatic transmission.
 - Pay attention because the oil to be used differs from that is used in the Nissan Full Automatic Transmission 3N71A. Never mix the oil with that.

Inspection and repair of oil leakage

When oil leakage takes place, the portion near the leakage is covered with oil, presenting difficulty in detecting the spot. Therefore, the places where oil seals and gaskets are equipped are enumerated below:

- Converter housing
 - The rubber ring of oil pump housing.
 - The oil seal of oil pump housing.
 - The oil seal of engine crankshaft.
 - The bolts of converter housing to case.
- Transmission and rear extension
 - Junction of transmission and rear extension.
 - Oil cooler tube connectors.
 - Oil pan.
 - Oil-pressure inspection holes (Refer to Figure AT-112).
 - The mounting portion of vacuum diaphragm and downshift solenoid.
 - Breather and oil charging pipe.
 - Speedometer pinion sleeve.
 - The oil seal of rear extension.

To exactly locate the place of oil leakage, proceeds as follows:

- Place the vehicle in a pit, and by sampling the leaked oil, examine whether it is the torque converter oil or not. The torque converter oil assumes a color like red wine when shipped from the factory, so it is easily distinguished from engine oil or gear oil.
- Cleanly wipe off the leaking oil and dust and detect the spot of oil leakage. Use nonflammable organic solvent such as carbon tetrachloride for wiping.
- Raise the oil temperature by operating the engine and shift the lever to "D" to heighten the oil pressure. The spot of oil leakage will then be found more easily.

Note: As the oil leakage from the breather does not take place except when running at high speed, it is impossible to locate the spot of leakage with vehicle stalled.

Checking engine idling rpm

The engine idling revolution should be properly adjusted.

If the engine revolution is too low, the engine does not operate smoothly, and if too high, a strong shock or creep develops when changing over from "N" to "D" or "R."

Specified idling speed:

- 600 rpm at "D" position
- (750 rpm at "N" position)

Checking and adjusting kick-down switch and downshift solenoid

When the kick-down operation is not made properly or the speed changing point is too high, check the kick-down switch, downshift solenoid, and wiring between them. When the ignition key is positioned at the 1st stage and the accelerator pedal is depressed deeply, the switch contact should be closed and the solenoid should click. If it does not click, it indicates a defect. Then check each part with the testing instruments. See Figure AT-109.

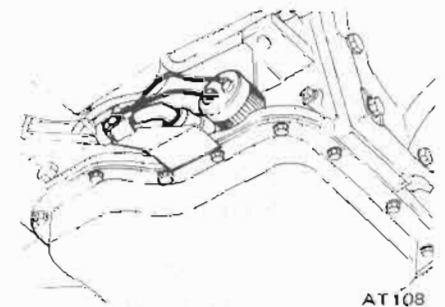

Fig. AT-109 Downshift solenoid

Note: Watch for oil leakage from transmission case.

Inspection and adjustment of manual linkage

The adjustment of linkage is equally important as "Inspection of oil level" for the automatic transmission. Therefore, great care should be exercised because defective adjustment will result in the breakdown of the transmission.

Inspection:

Pull the selector lever toward you and turn it so far as "P" to "1" range, where clicks will be felt by hand. This is the detent of manual valve in the body, and indicates the correct position of the lever.

Inspect whether the pointer of selector dial corresponds to this point, and also whether the lever comes in alignment with the stepping of position plate when it is released.

Adjustment:

This procedure can be accomplished by referring to "Removal and Installation."

Checking and adjusting inhibitor switch

The inhibitor switch serves to light the reverse lamp in the range "R" of the transmission operation and also to rotate the starter motor in the ranges "N" and "P."

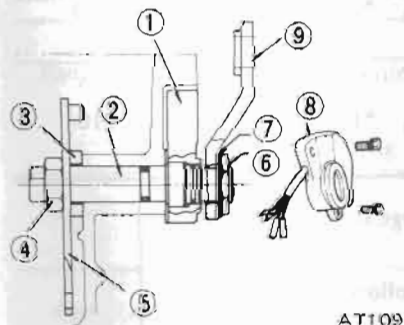

AT-109

- | | |
|--------------------|----------------------|
| 1 Inhibitor switch | 6 Washer |
| 2 Manual shaft | 7 Nut |
| 3 Washer | 8 Inhibitor switch |
| 4 Nut | 9 Range select lever |
| 5 Manual plate | |

Fig. AT-110 Construction of inhibitor switch

Check whether the reverse lamp and the starter motor operate normally in these ranges. If there is any trouble, first check the linkage. If no defect is found in the linkage, check the inhibitor switch.

Separate the manual lever from the remote control selector rod and turn the range select lever to "N."

Note: In the position "N" the slot of the manual shaft is vertical.

By the use of the tester, check the two black-yellow (BY) wires from the inhibitor switch in the ranges "N" and "P" and the two red-black (RB) wires in the range "R" for continuity. Turn range select lever to both directions from each lever set position and check each continuity range. It is normal if the electricity is on while the lever is within an angle of about 3° on both sides from each lever set line. However, if its continuity range is obviously unequal on both sides, the adjustment is required.

If any malfunction is found, unscrew the fastening nut of the range selector lever and two fastening bolts of the switch body and then remove the machine screw under the switch body. Adjust the manual shaft correctly to the position "N" by means of the selector lever. (When the slot of the shaft becomes vertical, the detent works to position the shaft correctly with a click sound.)

Move the switch slightly aside so that the screw hole will be aligned with the pin hole of the internal rotor combined with the manual shaft and check their alignment by inserting a 1.5 mm (0.0591 in) diameter pin into the holes. If the alignment is made correct, fasten the switch body with the bolts, pull out the pin and tighten up the screw again into the hole, and fasten the selector lever as before. Check over again the continuity with the tester. If the malfunction still remains, replace the inhibitor switch.

STALL TEST

The purpose of this test is to check the transmission and engine for trouble by measuring the maximum numbers of revolutions of the engine while

vehicle is held in a stalled condition and the carburetor is in full throttle operation with the selector lever in ranges "D," "2" and "1" respectively and by comparing the measured results with the standard values.

Standard stall revolution:

2,150 to 2,350 rpm

Components to be tested and test items

1. Clutches, brake and band in transmission for slipping.
2. Torque converter for function
3. Engine for overall property

Stall test procedures

Before testing, check the engine oil and torque converter oil, warm up the engine cooling water to the suitable temperature by warming up operation at 1,200 rpm with the selector lever in the range "P" for several minutes, and warm up the torque converter oil to the suitable temperature [60 to 100°C (140 to 212°F)].

1. Mount the engine tachometer at a location that allows good visibility from the driver's seat and put a mark on specified revolutions on the meter.
2. Secure the front and rear wheels completely with chocks and apply the hand brake. Be sure to depress the brake pedal firmly with the left foot before depressing down the accelerator pedal.
3. Throw the selector lever into the range "D."
4. Slowly depress the accelerator pedal down till the throttle valve is fully opened. Quickly read and record the engine revolution when the engine begins to rotate steadily and then release the accelerator pedal.
5. Turn the selector lever into "N" and operate the engine at approximately 1,200 rpm for more than one minute to cool down the torque converter oil and coolant.
6. Make similar stall tests in the ranges "2," "1" and "R."

Note: The stall test operation as specified in the item (4) should be made within five seconds. If it takes too long, the oil deteriorates and the clutches, brake

and band are adversely affected. Sufficient cooling time should be given between each test for the four ranges "D," "2," "1" and "R."

Judgement

1. High stall revolution more than standard revolution

If the engine revolution in stall condition is higher than the standard values, it indicates that one or more clutches in the transmission are slipping and, therefore, no further test is required.

For the following abnormalities, the respective causes are presumed.

- High rpm in all ranges . . . Low line pressure
- High rpm in "D," "2" and "1" and normal rpm in "R" . . . Rear clutch slipping
- High rpm in "D" and "2" and normal rpm in "1" . . . One-way clutch slipping
- High rpm in "R" only . . . Front clutch or low and reverse brake slipping

To determine which is slipping, either front clutch or low and reverse brake, a road test is needed.

If, while coasting after starting with the lever in "1" range, engine braking does not work properly, it is determined the low and reverse brake is slipping. Otherwise, the front clutch is slipping.

The slipping of the band brake is difficult to ascertain. However, if it occurs with the lever in "2" range, the engine revolution increases up to the same level as in "1st" speed and therefore it can be found out by careful observation. It is impossible to check it in the stall test.

2. Standard stall revolution

If the engine revolution in stall condition is within the standard values, the control elements are normally operating in the ranges "D," "2," "1" and "R."

Also, the engine and one way clutch of the torque converter are normal in performance and operation.

The one way clutch of the torque

converter, however, sometimes sticks. This should be determined in the road test.

3. Low stall revolution less than standard revolution

If the engine revolution in stall condition is lower than the standard values, it indicates that the engine is in abnormal condition or the torque converter's one-way clutch is slipping.

4. Others

(1) If the accelerating performance is poor until vehicle speed of approximately 50 km/h (30 MPH) is attained and then normal beyond that speed, it can be judged that the torque converter's one-way clutch is slipping.

(2) If the torque converter's one-way clutch sticks, vehicle speed can not exceed approximately 80 km/h

(50 MPH) in the road test. In such a case, the torque converter oil temperature rises up abnormally and so special care is required.

(3) If the transmission does not operate properly in all vehicle speeds, it indicates poor engine performance.

ROAD TEST

An accurate knowledge of the automatic transmission is prerequisite to its exact diagnosis by a road test.

It is recommended to prepare a diagnosis guide chart in which are written the standard vehicle speeds for each stage of the up- and down-shiftings. Measured vehicle speeds are to be filled in the adjoining column in each testing.

Also it is advisable to mount a stopper for positioning the throttle opening.

Car speed at gear shift

Throttle opening (mmHg)	Gear shift	Propeller shaft rpm
Kick-down (0)	D ₁ → D ₂	1,660 to 2,160
	D ₂ → D ₃	3,030 to 3,530
	D ₃ → D ₂	3,180 to 2,680
	D ₂ → D ₁	1,650 to 1,150
Half throttle (200)	D ₁ → D ₂	330 to 830
	D ₂ → D ₃	1,530 to 2,030
	D ₃ → D ₂ or D ₃ → D ₁	1,260 to 760
	D ₂ → D ₁	700 Max.
Full throttle (0)	1 ₂ → 1 ₁ *1	1,710 to 1,210
Minimum throttle (450)	1 ₂ → 1 ₁ *1	1,710 to 1,210

*1 Reduce the speed by shifting to "1" range from "D" range (output shaft 2,000 rpm).

Note: Car speed can be calculated by the following formula:

$$V = \frac{2 \times \pi \times r \times N_p \times 60}{R_f \times 1,000}$$

where, V = Car speed (km/h)

N_p = Propeller shaft revolution (rpm)

R_f = Final gear ratio

r = Tire effective radius (m)

π = The ratio of circumference of a circle to its diameter: 3.14

AUTOMATIC TRANSMISSION

Checking speed changing condition

The driver's feeling during gear changes should also be checked attentively.

1. A sharp shock or unsmoothness are felt during a gear change.
2. A gear change is made with a long and dragging feeling.

These indicate that the throttle pressure is too low or some valve connected to the throttle is defective.

Checking items during speed change

1. In "D" range, gear changes, $D_1 \rightarrow D_2 \rightarrow D_3$ are effected. In "R" range, the speed does not increase.
2. The kick down operates properly.
3. By moving the lever from "D" into "1," gear changes $D_3 \rightarrow 2(1_2) \rightarrow 1_1$ are effected. In the ranges "1₂" and "1₁," the engine braking works properly.
4. In "1," the speed does not increase.
5. Should be quickly fixed at "2" range.
6. In "P," vehicle can be parked properly.

If any malfunction occurs in the second gear during the road test, that is, if vehicle shakes, drags or sling in shifting up from "D₁," directly to "D₃" or in shifting up from "D₁" to

"D₂," the brake band should be adjusted. If these troubles remain after

the brake band is adjusted, check the servo piston seal for oil leakage.

Shift schedule

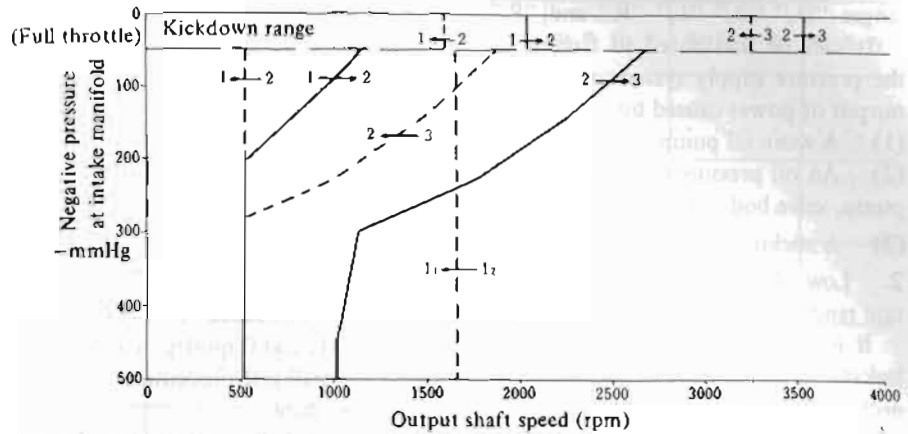

AT112

Fig. AT-111 Shift schedule

LINE PRESSURE TEST

When any slipping occurs in clutch or brake, or the feeling during a speed change is not correct, the line pressure must be checked.

Measuring the line pressure is done by a pressure gauge attached to two pressure measuring holes after removing blind plugs located at transmission case. See Figure AT-112.

The line pressure measurement is begun at idling and taken step by step by enlarging the throttle opening.

1. A sharp shock in up-shifting or too high changing speeds are caused mostly by too high throttle pressure.
2. Slipping or incapability of opera-

tion is mostly due to oil pressure leakage within the gear trains or spool valve.

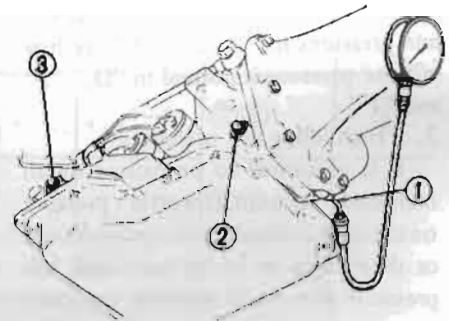

AT113

- 1 Line pressure
- 2 Governor feed
- 3 Servo release pressure

Fig. AT-112 Measuring line pressure

Line pressure (governor feed pressure)

Range	Throttle opening		At cut back point [under approximately 15 km/h (9 MPH)]	After cut back [over approximately 35 km/h (22 MPH)]
	Unit: mmHg		Unit: kg/cm ² (psi)	Unit: kg/cm ² (psi)
"D"	Full throttle	0	9.4 to 11.0 (134 to 156)	5.5 to 6.5 (78 to 92)
	Minimum throttle	450	3.0 to 4.0 (43 to 57)	3.0 to 4.0 (43 to 57)
"2"	Full throttle	0	10.0 to 12.0 (142 to 171)	5.5 to 7.0 (78 to 100)
	Minimum throttle	450	6.0 to 12.0 (85 to 171)	5.5 to 7.0 (78 to 100)
"R"	Full throttle	0	14.0 to 16.0 (199 to 228)	14.0 to 16.0 (199 to 228)
	Minimum throttle	450	3.0 to 5.5 (43 to 78)	3.0 to 5.5 (43 to 78)

- Notes: a. The line pressure during idling corresponds to the oil pressure before cut down at minimum throttle.
b. The oil pressure "After cut back" means that after the pressure modifier valve has operated.

CHASSIS

Judgement in measuring line pressure

1. Low idling line pressures in the ranges "D," "2," "1," "R" and "P."

It can be attributed to trouble in the pressure supply system or too low output of power caused by:

- (1) A worn oil pump
- (2) An oil pressure leakage in the oil pump, valve body or case
- (3) A sticking regulator valve

2. Low idling, line pressures in certain ranges only

It is caused presumably by an oil leakage in the devices or circuits connected to the relevant ranges.

- (1) When there is an oil leakage in the rear clutch and governor, the line pressures in "D," "2" and "1" are low but the pressure is normal in "R."
- (2) When an oil leakage occurs in the low and reverse brake circuit, the line pressures in "R" and "P" are low but the pressure is normal in "D," "2" and "1."

3. High idling line pressures

It is presumed to be caused by an increased vacuum throttle pressure owing to a leakage in the vacuum tube or diaphragm or by an increased line pressure due to a sticking regulator

valve.

Vacuum leakage is checked by directly measuring the negative pressure after removing the vacuum pipe.

A puncture of the vacuum diaphragm can be easily ascertained because the torque converter oil is absorbed into the engine and the exhaust pipe blows up the white smoke.

4. Checking items when the line pressure is increasing

In this checking, the line pressure should be measured with vacuums of 450 mmHg and 0 mmHg in accordance with the stall test procedure. test procedure.

(1) If the line pressures do not increase despite the vacuum decrease, check whether the vacuum rod is incorporated.

(2) If the line pressures do not meet the standard, it is caused mostly by a sticking pressure regulating valve, pressure regulating valve plug, or amplifier.

TROUBLE-SHOOTING CHART

Inspecting items

1. Inspection with automatic transmission on vehicle.

- A Oil level
- B Range select linkage
- C Inhibitor switch and wiring
- D Vacuum diaphragm and piping
- E Downshift solenoid, kick-down switch and wiring
- F Engine idling rpm
- G Oil pressure (throttle)
- H Engine stall rpm
- I Rear lubrication
- J Control valve (manual)
- K Governor valve
- L Band servo
- M Transmission air check
- N Oil quantity
- O Ignition switch and starter motor
- P Engine adjustment and brake inspection

2. Inspection after inspecting automatic transmission on vehicle.

- m Rear clutch
- n Front clutch
- q Band brake
- r Low and reverse brake
- s Oil pump
- t Leakage of oil passage
- u One-way clutch of torque converter
- v One-way clutch of transmission
- w Front clutch check ball
- x Parking linkage
- y Planetary gear

AUTOMATIC TRANSMISSION

Trouble-shooting chart for 3N71B Automatic Transmission

(The number shown below indicates the sequence of the checking items to be taken up.)

Trouble	A B C D	E F G H	I J K L	M N O P	m n q r	s t u v	w x y
Engine can not start in "N," "P" ranges.	. 2 3 1
Engine start in other range than "N," "P" ranges.	. 1 2
Sharp shock in shifting from "N" to "D" range.	. . . 2	. 1 3 .	. 4	⑤
Vehicle will not run in "D" range (but runs in "2," "1" and "R" ranges).	. 1 2 .	. 3 ④
Vehicle will not run in "D," "1," "2" ranges (but runs in "R" range). Clutch slips. Very poor acceleration.	1 2 4 .	. 5 . .	6 3 . 7	⑧ ⑨
Vehicle will not run in "R" range (but runs in "D," "2" and "1" ranges.) Clutch slips. Very poor acceleration.	1 2 3 .	. 5 . .	6 4 . .	⑨⑧ . ⑦ .	. ⑩	⑪
Vehicle will not run in all ranges.	1 2 3 .	. 5 . .	6 4	⑦⑧ ⑨
Clutches or brakes somewhat slip in starting.	1 2 . 6	. . 3 .	. 5 . .	7 4	⑧⑨
Vehicle runs in "N" range.	. 1 3 . .	. 2 . .	④
Maximum speed not attained. Acceleration poor.	1 2 4 5	. 7 . 6	. 3 . 8	⑪⑫⑨⑩	⑬
Vehicle braked by throwing lever into "R" range. 3	2 1 . .	④ . ⑤ ⑥
Large creep. 1
No creep at all.	1 2 . .	. 3 . .	. 5 . .	. 4 . .	⑧⑨	⑥⑦
Failure to change gear from "2nd" to "3rd."	. 1 . 2	3 5 6 8	7 4 ⑨ . .	. ⑩
Failure to change gear from "1st" to "2nd."	. 1 . 2	3 5 6 8	7 4 . .	. ⑨ ⑩	⑪
Too high gear change point in case from "1st" to "2nd," from "2nd" to "3rd."	. . . 1	2 . 3 .	. 5 6 .	. 4 ⑦
Gear change from "1st" to "3rd" occurs. 2 4 .	3 1 ⑤ . .	. ⑥

MISSION CHASSIS

Trouble	A B C D	E F G H	I J K L	M N O P	m n q r	s t u v	w x y
Too sharp shock in change from "1st" to "2nd."	. . . 1	. . . 2	. 4 . 5	. 3 ⑥
Too sharp shock in change from "2nd" to "3rd."	. . . 1	2 . 3 .	. 3 . 5	4 ⑥
Almost no shock or clutches slipping in change from "1st" to "2nd."	1 2 . 3	. . 4 .	. 6 . 8	7 5 ⑨ .	. ⑩
Almost no shock or slipping in change from "2nd" to "3rd." Engine extremely races.	1 2 . 3	. . 4 .	. 6 . 8	7 5 . .	. ⑨ . .	. ⑩ . .	. ⑪ . .
Vehicle braked by gear change from "1st" to "2nd." 2 . .	. 1 . .	. ④ . ③ ⑤
Vehicle braked by gear change from "2nd" to "3rd." 3 . 2	. 1 ④
Failure to change gear from "3rd" to "2nd."	. . . 1 3 4 6	5 2 . .	. ⑦ ⑧ .	. ⑨
Failure to change gear from "2nd" to "1st" or from "3rd" to "1st."	. . . 1 3 4 6	5 2 ⑦ ⑧
Gear change shock felt during car speed decrease by releasing accelerating pedal.	. 1 . 2	3 . 4 .	. 5 6 ⑦
Too high change point in case from "3rd" to "2nd," from "2nd" to "1st."	. 1 . 2	3 . 4 .	. 5 6 ⑦
Kick-down does not operate by depressing pedal in "3rd" within kick-down vehicle speed.	. . . 2	1 4 5 .	. 3 ⑥ .	. ⑦
Kick-down operates or engine overruns by depressing pedal in "3rd" beyond kick-down vehicle speed limit.	. 1 . 2	. . 3 .	. 5 6 .	7 4 . .	. ⑧ . .	. ⑨
Extremely races or slips in changing from "3rd" to "2nd" by depressing pedal.	. . . 1	. . 2 .	. 4 . 6	5 3 . .	. ⑦ ⑧ .	. ⑨ . .	. ⑩ . .
Failure to change from "3rd" to "2nd" by changing lever into "2" range.	. 1 2 .	. 4 . 5	. 3 ⑥ .	. ⑦
Gear change from "2nd" to "1st" or from "2nd" to "3rd" in "2" range.	. 1 2 .	. 3

AUTOMATIC TRANSMISSION

Trouble	A B C D	E F G H	I J K L	M N O P	m n q r	s t u v	w x y
No shock at changing from "1" to "2" range or engine extremely races.	1 2 . 3	. 4 . 1	. 6 . .	7 5 ⑨ .	⑩
Failure to change from "3rd" to "2nd" by turning lever into "1" range.	. 1 2 .	. 4 5 7	6 3 . .	. ⑧⑨ .	. ⑩
Engine brake does not operate in "1" range.	. 1 2 .	. 4 . .	5 3 ⑥	. ⑦
Gear change from "1st" to "2nd" or from "2nd" to "3rd" in "1" range.	. 1 2 ③
Does not change from "2nd" to "1st" in "1" range.	1 2 4 5 6	7 3 ⑧	. ⑨
Large shock changing from "2nd" to "1st" in "1" range.	. . . 1	. . . 2	. 4 . .	. 3 ⑤
Vehicle will move when changing into "P" range or parking gear does not disengage by turning off "P" range.	. 1 ② .
Transmission overheats.	1 3 4	2 6 . 8	7 5 . .	. ⑨⑩⑪	⑫⑬⑭ ⑮
Oil shoots out during run. White smoke issues out from tail pipe during run.	1 . . 3	. . 5 6	2 7 . .	8 4 . .	. ⑨⑩⑪	⑫⑬⑭ ⑮
Offensive smell at oil charging pipe.	1 2 . .	③④⑤⑥	⑦⑧⑨ ⑩
Transmission noise in "P" and "N" ranges.	1 2	③
Transmission noise in "D," "2," "1" and "R" ranges.	1 2	③ . . .	④ . . ⑤	. . . ⑥

CHASSIS

Trouble-shooting guide for 3N71B Automatic Transmission

Order	Test item	Procedure
Checking	<ol style="list-style-type: none"> 1. Oil level gauge 2. Downshift solenoid 3. Manual linkage 4. Inhibitor switch 5. Engine idling rpm. 6. Vacuum pressure of vacuum pipe. 7. Operation in each range. 8. Creep of vehicle. 	<p>Check gauge for oil level and leakage before and after each test.</p> <p>Check by sound whether solenoid operates when depressing accelerating pedal fully with ignition key "ON."</p> <p>Check changing conditions into "P," "R," "N," "D," "2" and "1" ranges by moving selector lever.</p> <p>Check whether starter operates in "N" and "P" ranges only and whether reverse lamp operates in "R" range only.</p> <p>Check whether idling rpm meet standard.</p> <p>Checking whether vacuum pressure is more than 450 mmHg in idling and whether it decreases with increasing rpm.</p> <p>Check whether transmission engages positively by shifting "N"→"D," "N"→"2," "N"→"1" and "N"→"R" range while idling with brake applied.</p> <p>Check whether there is any creep in "D," "2," "1" and "R" ranges.</p>
Stall test	<ol style="list-style-type: none"> 1. Oil pressure before testing. 2. Stall test. 3. Oil pressure after testing 	<p>Measure line pressures in "D," "2," "1," and "R" range while idling.</p> <p>Measure engine rpm and line pressure in "D," "2," "1" and "R" ranges during full throttle operation.</p> <p>Notes:</p> <ol style="list-style-type: none"> a. Temperature of torque converter oil used in test should be from 60° to 100°C (140° to 212°F) i.e., sufficiently warmed up but not overheated. b. For cooling oil between each stall test for "D," "2," "1" and "R" ranges, idle engine, i.e., rpm at about 1,200 rpm for more than 1 minute in "P" range. Measurement time must not be more than 5 seconds. <p>Same as the item 1.</p>
Road test	<ol style="list-style-type: none"> 1. Slow acceleration, 1st→2nd, 2nd→3rd 2. Quick acceleration, 1st→2nd 2nd→3rd 3. Kick-down operation, 3rd→2nd or 2nd→1st 	<p>Check vehicle speeds and engine rpm in shifting up 1st→2nd range and 2nd→3rd range while running with lever in "D" range and engine vacuum pressure of about 200 mmHg.</p> <p>Same as the item 1 above except with engine vacuum pressure of 0 mmHg (i.e., in position just before kick-down).</p> <p>Check whether the kick-down operates and measure the time delays while running at 30, 40, 50, 60, 70 km/h (19, 25, 31, 38, 44 MPH) in "D₃" range.</p>

AUTOMATIC TRANSMISSION

Order	Test item	Procedure
	<p>4. Shift down, D₃→D₂→D₁</p> <p>5. Shift down, D₃→1₂→1₁</p> <p>6. Shift down, D₃→2</p> <p>7. Shift up, 1₁→1₂</p> <p>8. Shift up or down when starting in "2" range.</p> <p>9. Parking.</p>	<p>Check vehicle speeds and engine rpm in shifting down 3rd → 2nd → 1st (continued) while coasting with accelerating pedal released in "D₃" range and engine vacuum pressure of about 450 mmHg.</p> <p>Check for shifting down D₃ → 1₂ and engine braking, and further for shifting down 1₂ → 1₁ and engine braking, after shifting the lever into "1" range with the accelerator pedal released and the engine vacuum pressure of 0 mmHg while driving at about 50 km/h (31 MPH) in "D₃" range.</p> <p>Check for quick shifting down D₃ → 2 and engine braking, after shifting the lever into "2" range while driving at about 50 km/h (31 MPH) in "D₃" range. Further, check the transmission for being locked to the 2nd gear ratio regardless of vehicle speed.</p> <p>Check for the transmission not shifting up during acceleration, when starting in "1" range.</p> <p>Check the transmission for not shifting up or down during acceleration or deceleration, when starting in "2" range.</p> <p>Confirm that vehicle will not move on grade when shifting to "P" range.</p>
Others	Abnormal shock, oil leakage.	Put on record of observed conditions during these tests such as gear noise, abnormal noise of clutches and acceleration performance.

SERVICE DATA AND SPECIFICATIONS

General specifications

Torque converter

Type	Symmetrical 3-element 1-stage 2-phase torque converter coupling
Stall torque ratio	2.0 : 1

Transmission

Type	3-speed forward and one-speed reverse with planetary gear train
Control elements:	
Multiple-disc clutch	2
Band brake	1
Multiple-disc brake	1
One-way clutch	1

Gear ratio	1st	2.458
	2nd	1.458
	3rd	1.000
	Reverse	2.182

Selector positions	P (Park)	The transmission is placed in neutral. The output shaft is fixed. The engine can be started.
	R (Reverse)	Backward running
	N (Neutral)	The transmission is in neutral. The engine can be started.
	D (Drive)	Up- or downshifts automatically to and from 1st, 2nd, and top
	2 (2nd lock)	Fixed at 2nd
	1 (Lock up)	Fixed at low or downshifts from 2nd

Oil pump

Type	Internally intermeshing involute gear pump
Number of pump	1
Oil	Automatic transmission fluid "Dexron" type
Capacity	5.5 liters (5 7/8 U.S.qts., 4 7/8 Imp.qts.)
	Approximately 2.7 liters (2 7/8 U.S.qts., 2 3/8 Imp.qts.) in torque converter

Hydraulic control system	Controlled by detecting the negative pressure of intake manifold and the revolution speed of output shaft.
--------------------------------	--

Lubrication system	Forced lubrication by an oil pump
--------------------------	-----------------------------------

Cooling system	Water-cooled by a circulation-type auxiliary cooler (located at the radiator).
----------------------	--

AUTOMATIC TRANSMISSION

Specifications and adjustment

Automatic transmission assembly

Model code number X0700

Torque converter assembly

Stamped mark on the T/C 20-D

Front clutch

Number of drive plates 3

Number of driven plates 3

Clearance mm (in) 1.6 to 1.8 (0.0630 to 0.0709)

Thickness of retaining plate mm (in) 10.6 (0.417)

10.8 (0.425)

11.0 (0.433)

11.2 (0.441)

11.4 (0.449)

11.6 (0.457)

Rear clutch

Number of drive plates 6

Number of driven plates 6

Clearance mm (in) 1.0 to 1.5 (0.039 to 0.059)

Thickness of retaining plate mm (in) 4.8 (0.189)

Low & reverse brake

Number of drive plates 5

Number of driven plates 5

Clearance mm (in) 0.80 to 1.05 (0.031 to 0.041)

Thickness of retaining plate mm (in) 7.8 (0.307)

8.0 (0.315)

8.2 (0.323)

8.4 (0.331)

8.6 (0.339)

8.8 (0.346)

Brake band

Piston size mm (in)

Big dia. 80 (3.150)

Small dia. 50 (1.969)

Control valve assembly

Stamped mark on strainer E24

Governor assembly

Stamped mark on governor body 33

Engine idling and stall revolution

(Engine with emission control device)

Idling revolution	rpm	600 at "D" position (750 at "N" position)
Stall revolution	rpm	2,150 to 2,350

Tightening torque kg-m(ft-lb)

Drive plate to crankshaft	14.0 to 16.0	(101 to 116)
Drive plate to torque converter	4.0 to 5.0	(30 to 36)
Converter housing to engine	4.0 to 5.0	(30 to 36)
Transmission case to converter housing	4.0 to 5.0	(30 to 36)
Transmission case to rear extension	2.0 to 2.5	(15 to 18)
Oil pan to transmission case	0.5 to 0.7	(3.6 to 5.1)
Servo piston retainer to transmission case	0.5 to 0.7	(3.6 to 5.1)
Piston stem (when adjusting band brake)	*1.2 to 1.5	(8.7 to 10.8)
Piston stem lock nut	1.5 to 4.0	(11 to 29)
One way clutch inner race to transmission case	1.3 to 1.8	(9.4 to 13)
Control valve body to transmission case	0.55 to 0.75	(4.0 to 5.4)
Lower valve body to upper valve body	0.25 to 0.35	(1.9 to 2.5)
Side plate to control valve body	0.25 to 0.35	(1.9 to 2.5)
Nut for control valve reamer bolt	0.5 to 0.7	(3.6 to 5.1)
Oil strainer to lower valve body	0.25 to 0.35	(1.9 to 2.5)
Governor valve body to oil distributor	0.5 to 0.7	(3.6 to 5.1)
Oil pump housing to oil pump cover	0.6 to 0.8	(4.4 to 5.8)
Inhibitor switch to transmission case	0.5 to 0.7	(3.6 to 5.1)
Manual shaft lock nut	3.0 to 4.0	(22 to 29)
Lock nut for oil cooler pipe connector to transmission case	3.0 to 5.0	(22 to 36)
Oil cooler pipe connecting nut	0.7 to 1.1	(5.0 to 7.9)
Test plug (oil pressure inspection hole)	1.4 to 2.1	(10 to 15)
Support actuator (parking rod inserting position) to rear extension	0.8 to 1.1	(5.8 to 7.9)
Oil charging pipe to case	0.55 to 0.75	(4.0 to 5.4)
Dust cover to converter housing	0.55 to 0.75	(4.0 to 5.4)
Selector range lever to manual shaft	3.0 to 4.0	(22 to 29)
Selector rod lock nut	0.8 to 1.1	(5.8 to 7.9)
Control lever bracket to floor	0.8 to 1.1	(5.8 to 7.9)
Control lever knob to lever	0.20 to 0.25	(1.4 to 1.8)

* Turn back two turns after tightening.