

# SERVICE MANUAL

DATSUN 240Z SPORTS  
MODEL S30 SERIES  
**CHASSIS & BODY**



**NISSAN**

**NISSAN MOTOR CO., LTD.**  
TOKYO, JAPAN

## SECTION BR

### BRAKE

Inspection	BR-4
Assembly	BR-5
Disassembly	BR-5
BRAKE LINE	BR-1
PROPORTIONING VALVE	BR-1
Master	BR-5
Slave	BR-5
Check of air resistance	BR-5
WAXY LINE PRESSURE DIFFERENTIAL	BR-5
WARNING LIGHT SWITCH	BR-5

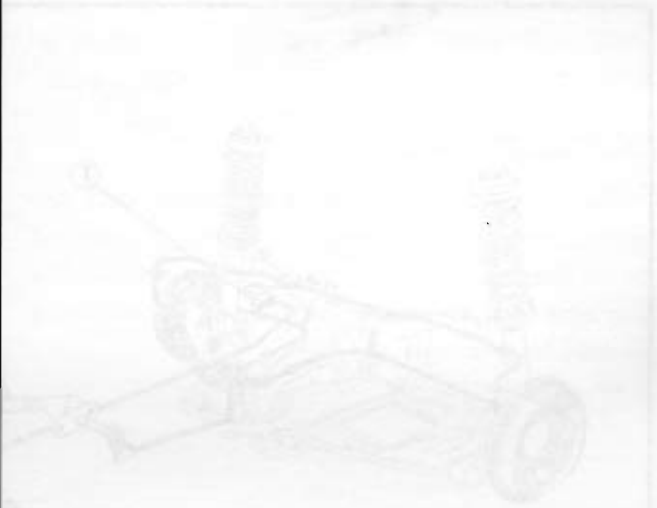

**BR**

BRAKE SYSTEM	BR- 1
FRONT DISC BRAKE	BR- 9
REAR BRAKE	BR-13
HAND BRAKE	BR-18
MASTER-VAC	BR-21
SERVICE DATA AND SPECIFICATIONS	BR-27
TROUBLE DIAGNOSES AND CORRECTIONS	BR-28

# BRAKE

## BRAKE SYSTEM

### CONTENTS

DESCRIPTION .....	BR-2	Inspection .....	BR-4
BRAKE PEDAL .....	BR-2	Reassembly .....	BR-5
Removal .....	BR-2	Reinstallation .....	BR-5
Inspection .....	BR-2	BRAKE LINE .....	BR-5
Reinstallation .....	BR-2	PROPORTIONING VALVE .....	BR-6
ADJUSTMENT .....	BR-2	Operation .....	BR-6
Adjusting brake pedal .....	BR-2	Inspection .....	BR-8
MASTER CYLINDER .....	BR-3	Removal and reinstallation .....	BR-8
Removal .....	BR-4	BRAKE LINE PRESSURE DIFFERENTIAL	
Disassembly .....	BR-4	WARNING LIGHT SWITCH .....	BR-8

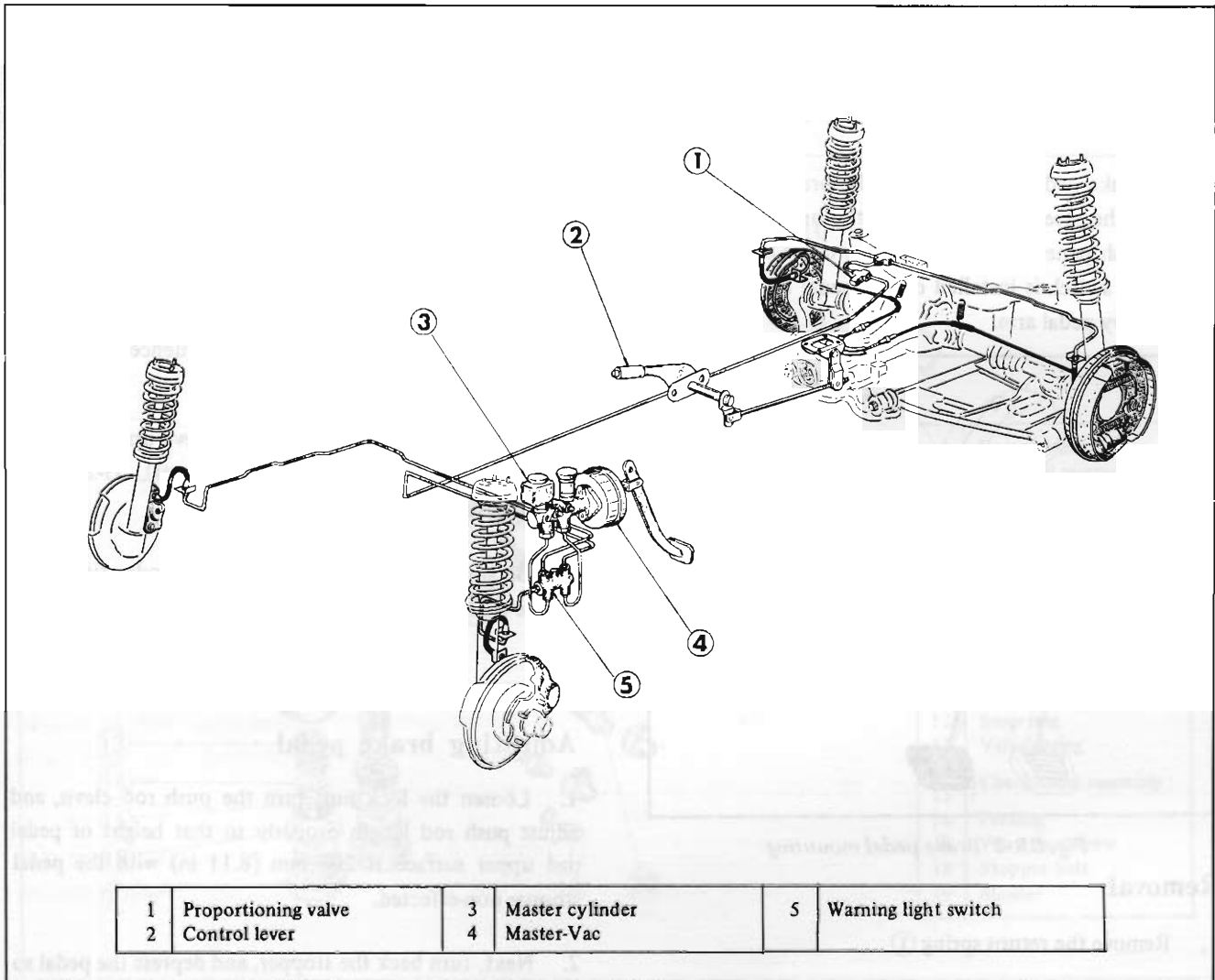

Fig. BR-1 Brake system

# CHASSIS

## DESCRIPTION

The S30 series vehicles are equipped with disc brake for front, drum brake for rear, and a six inch master-vac, to get great braking force.

The front disc brake is Girling-Sumitomo model S-16, and the pad is operated with two pistons.

The leading-trailing type rear drum brake is equipped with auto-adjuster, and in order to get enough cooling effect, aluminum lined brake drums are used.

Moreover, the brake system is equipped with a proportioning valve to prevent skid due to early rear wheel locking.

The hand brake is of a mechanical type, which brakes rear wheels, and is operated by the control lever through linkage and wire.

The control lever is located in the seat side center, and is operated easily. The hand brake force satisfies the MVSS sufficiently, and it may also be used as an emergency brake.

## BRAKE PEDAL

The brake pedal is installed on the bracket which also supports the steering column, and the bracket is secured on the dash panel together with the master cylinder. The stop lamp switch is installed on the pedal bracket, and is operated by pedal arm.

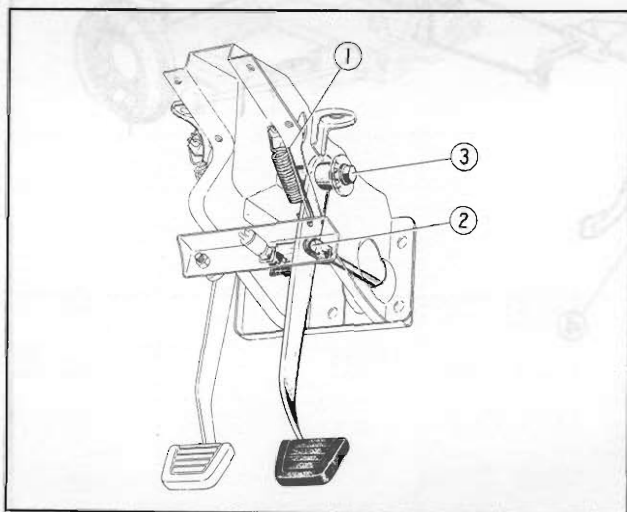

Fig. BR-2 Brake pedal mounting

### Removal

1. Remove the return spring ①.
2. Remove the clevis pin ② from the push rod, and separate the pedal from the master vac.

3. Remove the fulcrum pin ③ and remove the pedal.

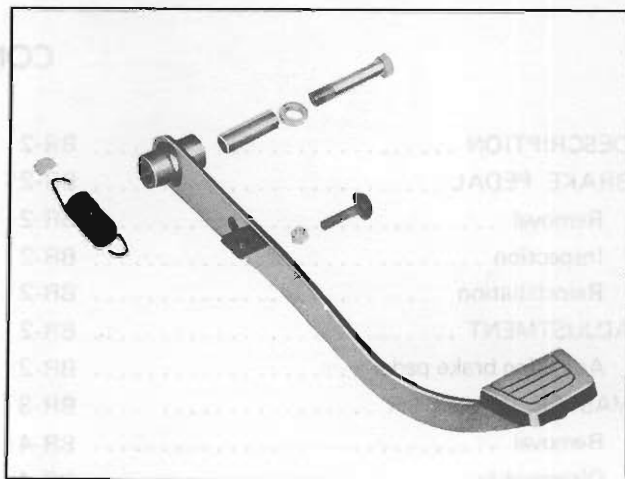

Fig. BR-3 Brake pedal components

### Inspection

Check the brake pedal for the following items, and correct or replace if required.

1. Pedal bushing and sleeve for wear, deformation, and/or damage.
2. Pedal arm for twisting, bending, and/or cracking.

### Reinstallation

Install the brake pedal in reverse sequence of removal, noting following matters.

1. Be sure to fill the pedal shaft sleeve unit and clevis pin unit with multipurpose grease (MIL G-2108 or G-10924) sufficiently.
2. Be sure to tighten the fulcrum pin under tightening torque of 3.5 to 4.0 kg-m (25.3 to 28.9 ft-lb).

### ADJUSTMENT

#### Adjusting brake pedal

1. Loosen the lock nut, turn the push rod clevis, and adjust push rod length properly so that height of pedal pad upper surface is 206 mm (8.11 in) with the pedal stopper non-effected.
2. Next, turn back the stopper, and depress the pedal so that pedal pad height is reduced from 206 mm (8.11 in) to 203 mm (7.99 in).

# BRAKE

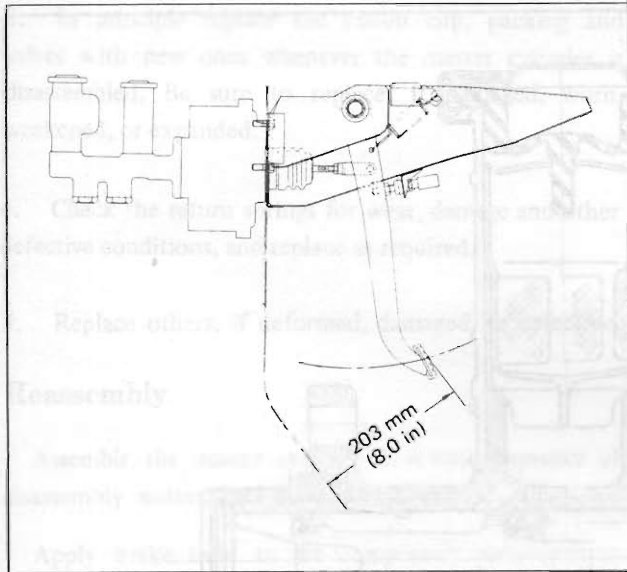

Fig. BR-4 Adjusting brake pedal

- Note: a. Install the stop lamp switch so that the installation screw end surface is flush against the bracket.
- b. After the above processes, make sure that the lamp is on when the pedal is pushed down by 15 mm (0.591 in) at the place of the brake pedal pad and it is off when the pedal is released. Repeat it for several times.

## MASTER CYLINDER

The brake system adopts a tandem type master cylinder. Even the front or rear hydraulic circuit falls into

a trouble, sufficient braking force can be obtained by another. For the front wheels, the disc brake is used, and thus, a large capacity reservoir is used.

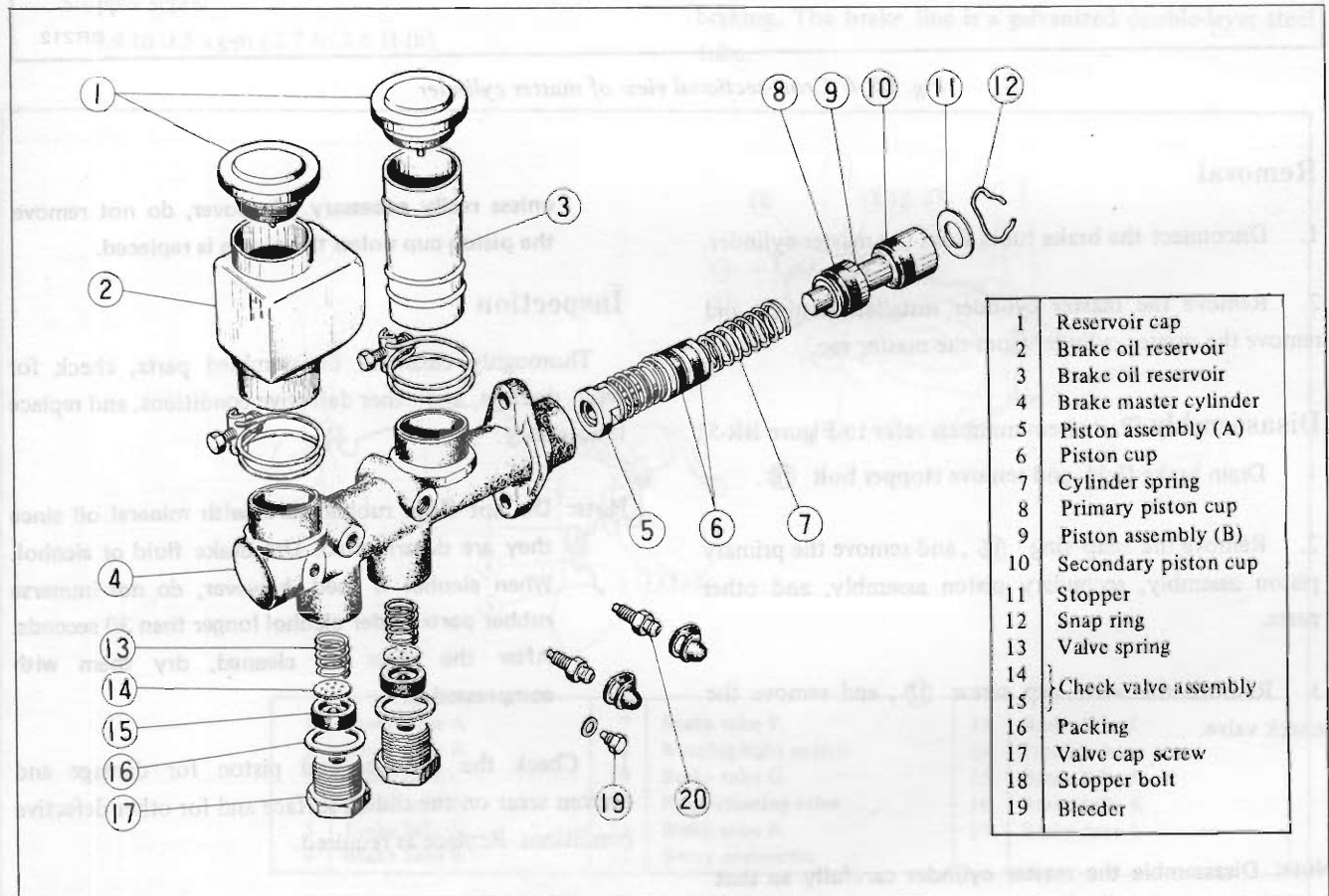
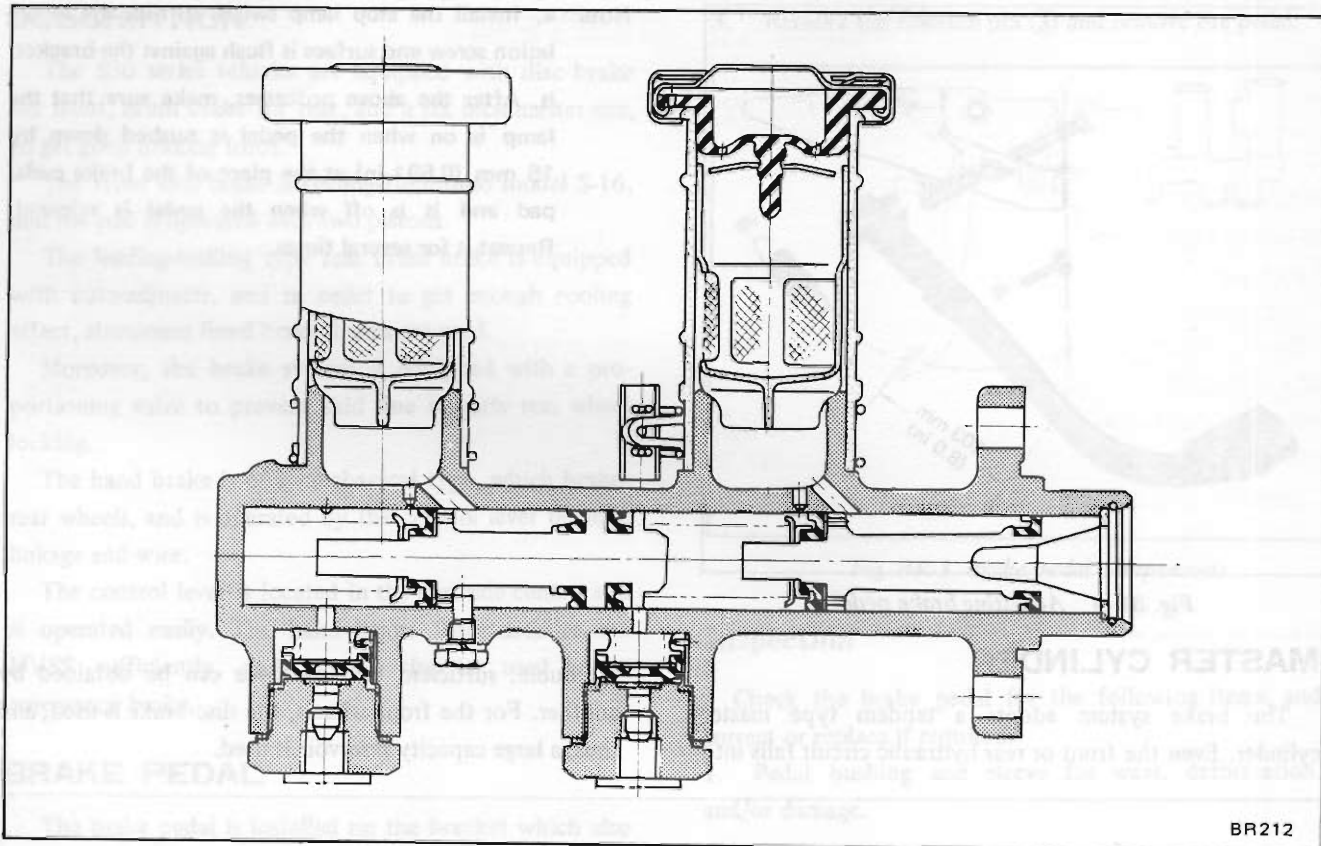

Fig. BR-5 Master cylinder

# CHASSIS



BR212

Fig. BR-6 Cross-sectional view of master cylinder

## Removal

1. Disconnect the brake tubes from the master cylinder.
2. Remove the master cylinder installation nuts, and remove the master cylinder from the master vac.

## Disassembly (Parts item numbers refer to Figure BR-5)

1. Drain brake fluid, and remove stopper bolt ⑱.
2. Remove the snap ring ⑫, and remove the primary piston assembly, secondary piston assembly, and other parts.
3. Remove the valve cap screw ⑰, and remove the check valve.

**Note:** Disassemble the master cylinder carefully so that the sliding surface of the piston and piston cup are not damaged. Do not remove the fluid reservoir

unless really necessary. Moreover, do not remove the piston cup unless the piston is replaced.

## Inspection

Thoroughly clean all disassembled parts, check for wear, damage, and other defective conditions, and replace if necessary.

**Note:** Do not clean rubber parts with mineral oil since they are deteriorated. Use brake fluid or alcohol. When alcohol is used, however, do not immerse rubber parts under alcohol longer than 30 seconds. After the parts are cleaned, dry them with compressed air.

1. Check the cylinder and piston for damage and uneven wear on the sliding surface and for other defective conditions. Replace as required.
2. Replace, if the cylinder and piston clearance is more than 0.15 mm (0.006 in).



# BRAKE

3. In principle replace the piston cup, packing and valves with new ones whenever the master cylinder is disassembled. Be sure to replace, if damaged, worn, weakened, or expanded.

4. Check the return springs for wear, damage and other defective conditions, and replace as required.

5. Replace others, if deformed, damaged, or defective.

## Reassembly

Assemble the master cylinder in reverse sequence of disassembly, noting the following matters.

Apply brake fluid to the component parts such as cylinder bore, piston, etc., and install carefully so as not to damage them. Moreover, for rubber parts such as piston cup, etc., apply rubber grease slightly.

## Tightening torque

Stopper screw

0.4 to 0.5 kg-m (2.7 to 3.6 ft-lb)

• Valve cap

8 to 9 kg-m (5.8 to 6.5 ft-lb)

## Reinstallation

Reinstall the master cylinder in reverse sequence of removal. After air bleeding, make sure that no brake fluid leaks from the circuit. For the pedal height adjustment, refer to the paragraph pedal adjustment.

## BRAKE LINE

The brake lines branched from the tandem type master cylinder are extended to the front and rear wheels, forming independent hydraulic circuits. An indicator switch is equipped for trouble warning in brake line. In addition, the rear wheel side circuit is equipped with the proportioning valve in front of the 3-way connector so as to protect the rear wheels from locking during rapid braking. The brake line is a galvanized double-layer steel tube.

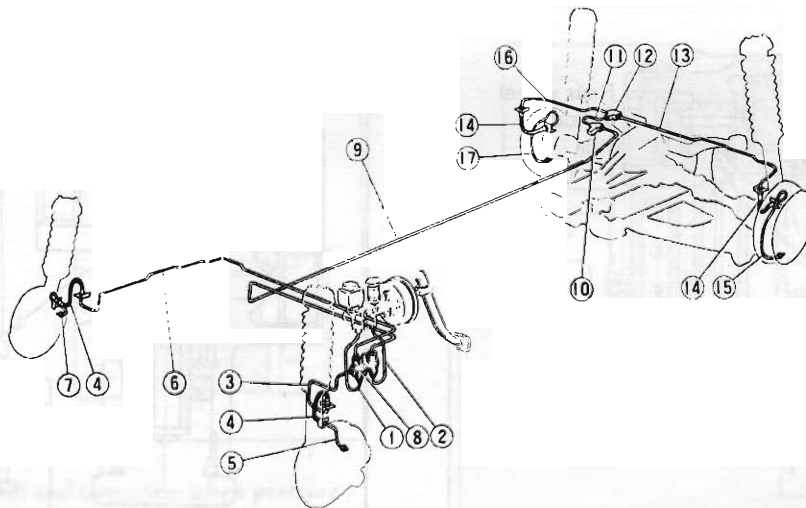

1	Brake tube A	7	Brake tube F	13	Brake tube I
2	Brake tube B	8	Warning light switch	14	Pressure hose
3	Brake tube C	9	Brake tube G	15	Brake tube J
4	Pressure hose	10	Proportioning valve	16	Brake tube K
5	Brake tube D	11	Brake tube H	17	Brake tube L
6	Brake tube E	12	3-way connector		

Fig. BR-7 Brake line

# CHASSIS

Check the brake lines (tubes and hoses) for crack and/or damage, and replace, if defective. When brake fluid leaks from the joint, retighten or replace.

Pay attention to the following matters when installing brake lines.

1. Provide a sufficient space between the brake lines and other parts so that the brake lines are not interfered with other parts due to vibration during driving.
2. Be careful not to warp or twist the brake hose, and particularly be careful not to bring the brake hose into contact with tires and suspension components.
3. Do not tighten the brake line installation flare nut forcedly or excessively.
4. Upon completion of the brake line installation, be sure to bleed the air.

## PROPORTIONING VALVE

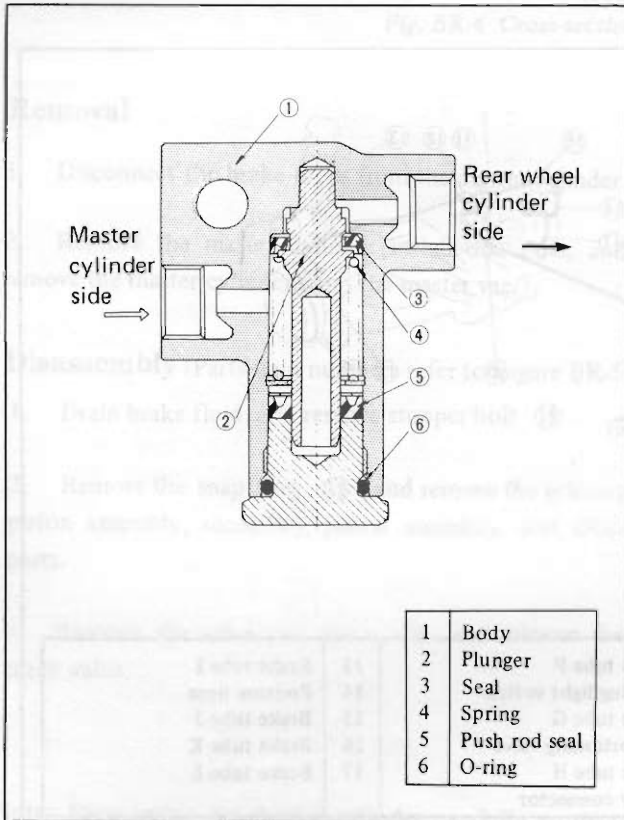

Fig. BR-8 Cross-sectional view of proportioning valve

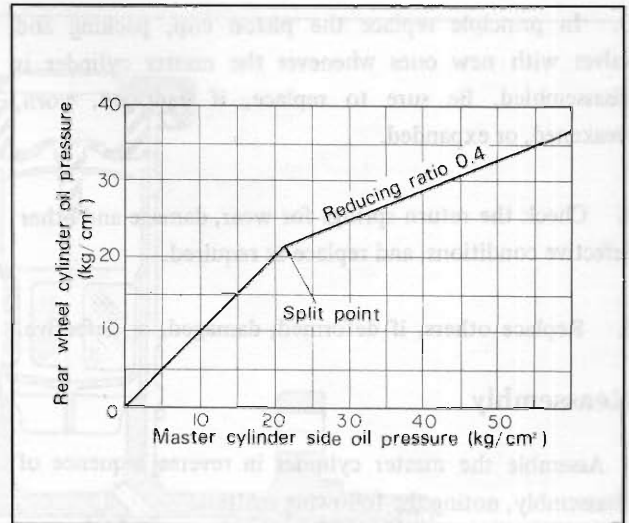

Fig. BR-9 Performance curve

## Operation

1. When pressure is applied (under split point)

- $P_1$ ; Master cylinder oil pressure
- $P_2$ ; Rear wheel cylinder oil pressure
- $A_1$ ; Cross-sectional area of diameter  $D_1$
- $A_2$ ; Cross-sectional area of diameter  $D_2$
- $F$ ; Spring and friction forces

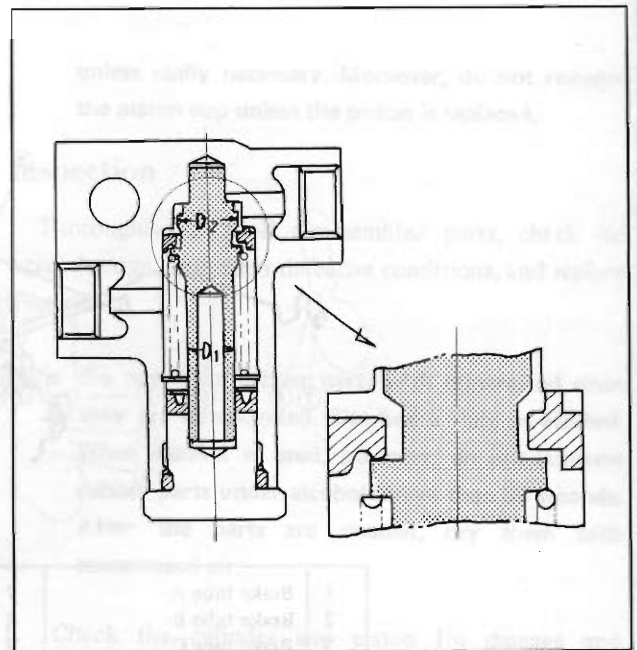

Fig. BR-10 Plunger and seal operation when pressure is applied (under split point)

The plunger is depressed downward by force of  $P_1 \times A_1$ , passage of seal is opened until it overcomes spring

# BRAKE

force  $F$ , and hence, oil pressure in the master cylinder side is balanced with that in the rear wheel cylinder side.

$$P_1 = P_2 \dots \dots \dots (1)$$

Consequently, oil pressure at the split point is expressed as follows:

$$P_s = F/A_1 \dots \dots \dots (2)$$

## 2. When pressure is applied (over split point)

When oil pressure rises to split point, the plunger lowers, and the circuit is sealed at "C" periphery. When oil pressure further rises, the plunger rises, the seal is released, the plunger finely rises and lowers so that pressures are balanced under the following equation, and thus, seal opening and closing are repeated.

$$P_2 \times A_2 = P_1(A_2 - A_1) + F \dots \dots \dots (3)$$

As the result, rear wheel cylinder side oil pressure rises in a ratio lower than that in the master cylinder side (reducing ratio).

$$\text{Reducing ratio} = \frac{A_2 - A_1}{A_2}$$

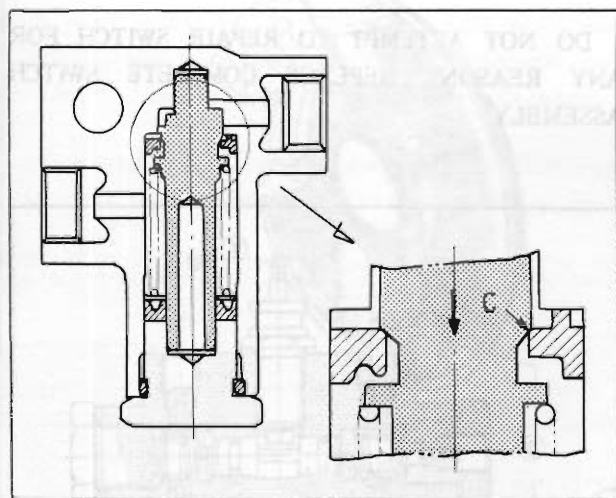

Fig. BR-11 Plunger and seal operation when pressure is applied (over split point)

## 3. When releasing

When master cylinder side oil pressure is reduced, the plunger drops to contact the stopper [refer to Figure BR-12(a)] depressing oil seal down.

And keeping balance of equation (3) the wheel cylinder side pressure is reduced also. But on this situation the wheel cylinder side pressure drops no more.

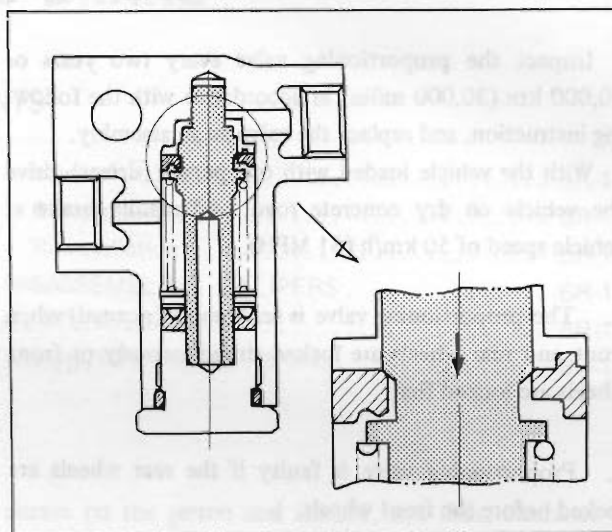

Fig. BR-12(a) Plunger and seal operation when releasing

As master cylinder side pressure is reduced further lower than the rear wheel cylinder side, the seal drops some more [refer to Figure BR-12(b)], and keeping balance of equation (1) the wheel cylinder side pressure is reduced also.

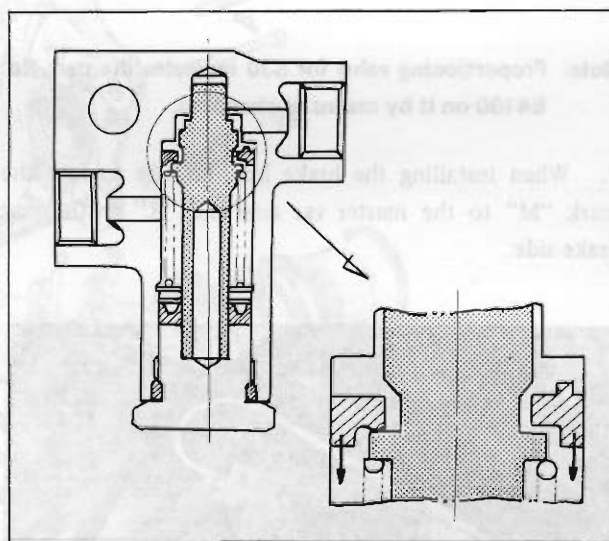

Fig. BR-12(b) Plunger and seal operation when releasing

When pressure further drops down to the split point, the plunger is pushed up by spring force, the condition recovers to the original condition, and with the balance of equation (1) being maintained, oil pressure drops. (refer to Figure BR-10)



# CHASSIS

## Inspection

Inspect the proportioning valve every two years or 50,000 km (30,000 miles) in accordance with the following instruction, and replace the valve as an assembly.

With the vehicle loaded with one person (driver), drive the vehicle on dry concrete road, and rapidly brake at vehicle speed of 50 km/h (31 MPH).

1. The proportioning valve is serviceable (normal) when front and rear wheels are locked simultaneously or front wheels are locked first.
2. Proportioning valve is faulty if the rear wheels are locked before the front wheels.

## Removal and reinstallation

The proportioning valve can be removed easily by removing the installation bolts. When reinstalling, however, note the following matters:

1. Appearance of proportioning valve for S30 series is the same as 510, C30 series vehicles. However, the performance differs. Be careful not to mix up.

**Note:** Proportioning valve for S30 indicates the part No. E4100 on it by means of stamping.

2. When installing the brake line, be sure to face the mark "M" to the master vac side and "R" to the rear brake side.

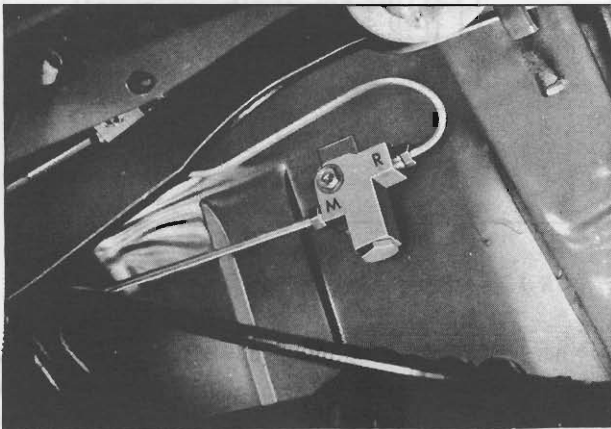

Fig. BR-13 Proportioning valve

## BRAKE LINE PRESSURE DIFFERENTIAL WARNING LIGHT SWITCH

A warning light is located on the instrument panel to warn the driver when a pressure difference of 13 to 17 kg/cm<sup>2</sup> (185 to 242 lb/sq in) exists between the front and rear brake systems.

A hydraulically actuated warning light switch is positioned in the engine compartment. Both front and rear brake systems are connected to this switch assembly.

When a pressure difference of 13 to 17 kg/cm<sup>2</sup> (185 to 242 lb/sq in) occurs between the front and rear brake systems, the valves will shuttle toward the side with the low pressure. The valve contacts with the switch terminal and the ground circuit for the warning light is completed, thus the warning light lights.

The hydraulic brake problem must then be corrected and bleed the brakes.

Check the warning light switch assembly for a proper operation. Check the switch assembly for fluid leakage.

**DO NOT ATTEMPT TO REPAIR SWITCH FOR ANY REASON: REPLACE COMPLETE SWITCH ASSEMBLY.**

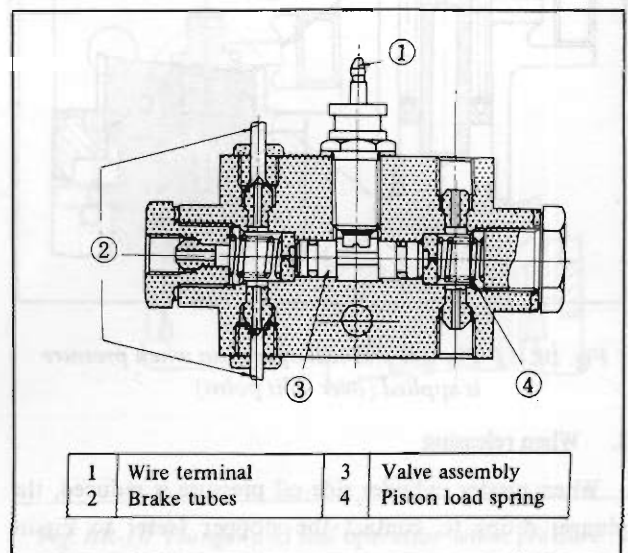

Fig. BR-14 Sectional view of warning light switch

# BRAKE

## FRONT DISC BRAKE

### CONTENTS

REPLACING PAD .....	BR-10	Inspection .....	BR-11
Removal .....	BR-10	Reassembly .....	BR-11
Inspection .....	BR-10	Reinstallation .....	BR-12
Reinstallation .....	BR-10	DISASSEMBLING CALIPERS .....	BR-12
REPLACING PISTON SEAL .....	BR-10	INSPECTING ROTOR .....	BR-12
Removal .....	BR-10	ADJUSTING FRONT BRAKE .....	BR-12
Disassembly .....	BR-11		

Girling-Sumitomo Model S-16 disc brake is used. Rigidity of the caliper is high, brake pedal feeling is adequate, and the pad dragging is minimized. The pad is returned by elasticity of the piston seal. When the pad is worn, the piston operating stroke increases, slipping

occurs on the piston seal surface, and thus, clearance is adjusted automatically.

Moreover, in order to prevent brake squealing, a shim is inserted behind the pad.

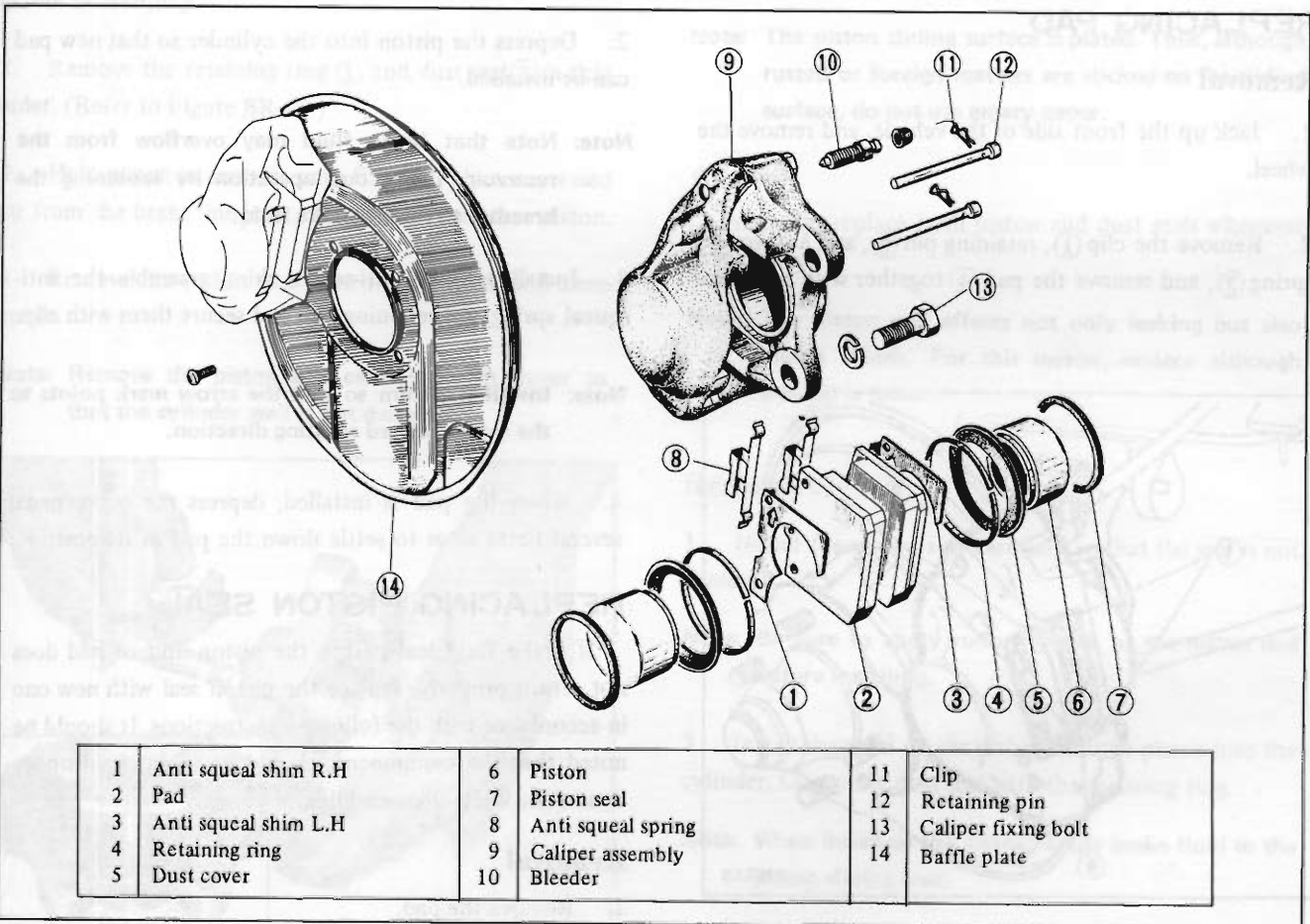

Fig. BR-15 Front disc brake

# CHASSIS

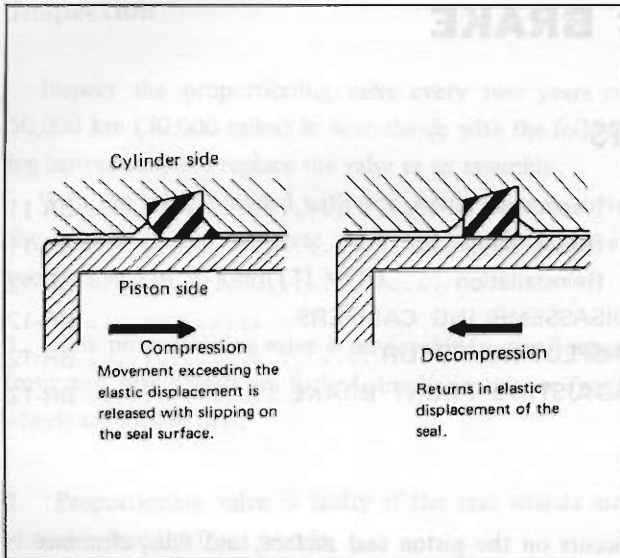

Fig. BR-16 Piston seal automatic adjusting operation

## REPLACING PAD

### Removal

1. Jack up the front side of the vehicle, and remove the wheel.
2. Remove the clip ①, retaining pin ②, and anti-squeal spring ③, and remove the pad ④ together with the shim.

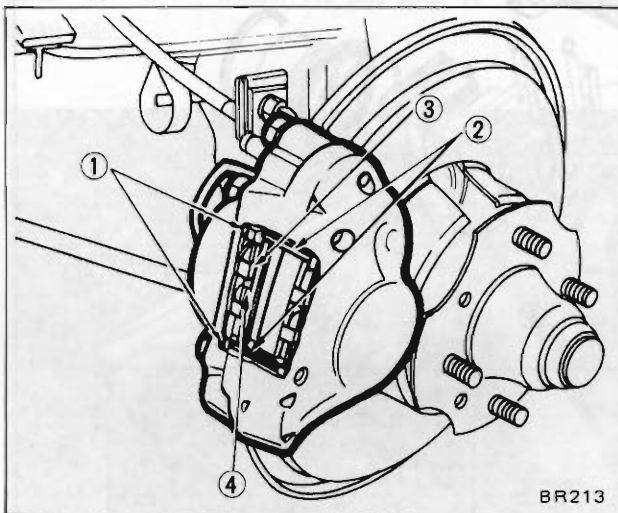

Fig. BR-17 Removing pad

### Inspection

1. Clean the pad with carbon tetrachloride or gasoline.
2. When oil and/or grease is heavily stuck on the pad, or when deteriorated or deformed due to overheating, replace the pad with a new one.
3. When thickness of the friction material is less than 2 mm (0.0787 in), replace. (Replace, when total pad thickness is less than 7.5 mm (0.2953 in).

**Note:** Replace pads as a set. Replacement at only one position may cause uneven brake effect. Rotation of pads is recommended to be made periodically.

### Reinstallation

1. Clean the calipers and piston pad installing parts.

**Note:** Do not use mineral oil. Be careful not to apply oil on the rotor.

2. Depress the piston into the cylinder so that new pad can be installed.

**Note:** Note that brake fluid may overflow from the reservoir. Carry out operation by loosening the breather to release brake fluid.

3. Install pad and anti-squeal shim, assemble the anti-squeal spring and retaining pin, and secure them with clip.

**Note:** Install the shim so that the arrow mark points to the rotor forward rotating direction.

4. When the pad is installed, depress the brake pedal several times so as to settle down the pad in its position.

## REPLACING PISTON SEAL

If brake fluid leaks from the piston unit or pad does not return properly, replace the piston seal with new one in accordance with the following instructions. It should be noted that the components should be maintained under clean state while disassembling.

### Removal

1. Remove the pad.
2. Disconnect the brake line ① and caliper installation

# BRAKE

bolt ②, and remove the caliper assembly from the knuckle spindle.

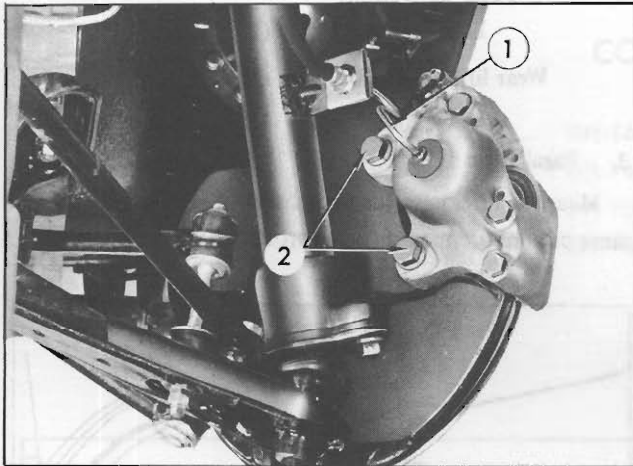

Fig. BR-18 Removing calipers

## Disassembly

1. Remove mud and dust from the caliper assembly before disassembly.
2. Remove the retaining ring ① and dust seal ② in that order. (Refer to Figure BR-15.)
3. Hold piston in one side with finger, apply compressed air from the brake line joint, and remove the other piston.
4. Remove the piston seal from the cylinder, and clean inside.

**Note:** Remove the piston seal carefully with finger so that the cylinder wall is not damaged.

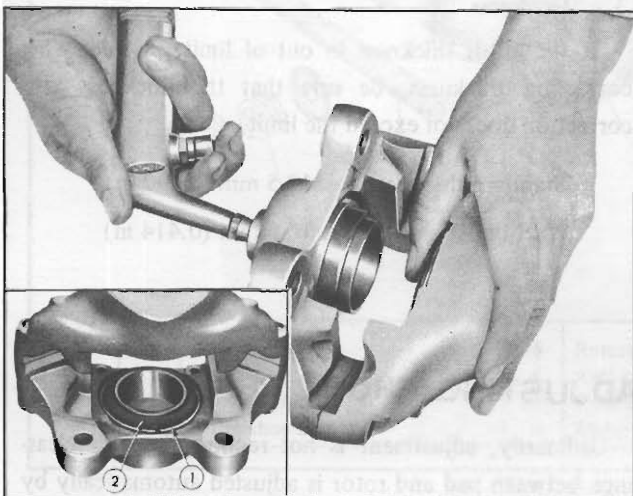

Fig. BR-19 Removing piston

## Inspection

Thoroughly clean all disassembled parts, and check them for the following items.

**Note:** When cleaning rubber parts, use alcohol or brake fluid. If rubber parts are cleaned with mineral oil, they will be deteriorated.

### 1. Calipers

If the cylinder wall is damaged or worn, replace. If the cylinder wall is rusted or foreign matters are accumulated on the cylinder wall, carefully polish with fine emery paper so that the cylinder wall is not damaged. If rusted or roughened excessively, replace.

### 2. Pad

See paragraph covering replacement of pad.

### 3. Piston

Replace, if unevenly worn, damaged, and/or rusted.

**Note:** The piston sliding surface is plated. Thus, although rusted or foreign matters are stuck on the sliding surface, do not use emery paper.

### 4. Seals

Primarily, replace both piston and dust seals whenever overhauling.

**Note:** The piston seal affects not only leaking but also piston return. For this reason, replace although damage is minor.

## Reassembly

1. Install the piston seal carefully so that the seal is not damaged.

**Note:** Be sure to apply rubber grease to the piston seal before installing.

2. Install dust seal on the piston, and the piston into the cylinder. Clamp the dust seal with the retaining ring.

**Note:** When inserting the piston, apply brake fluid to the piston sliding unit.

3. After reassembly is completely accomplished on one cylinder, assemble the another side in the same manner.



# CHASSIS

## Reinstallation

Reinstallation is reverse sequence of removal. After the pad is installed completely, bleed the hydraulic line.

## Tightening torque

Caliper attaching bolt  
7.3 to 9.9 kg-m (53 to 71 ft-lb)

## DISASSEMBLING CALIPERS

Do not remove the bridge bolt.

If brake fluid leaks from the bridge seal, replace a new assembly: (Be sure to replace the calipers as an assembly.)

## INSPECTING ROTOR

Remove the caliper assembly, check the rotor for deflection and damage, and correct or replace as required.

### 1. Deflection

With the wheel bearing adjusted correctly, measure deflection at the center of rotor pad contact surface using dial gauge.

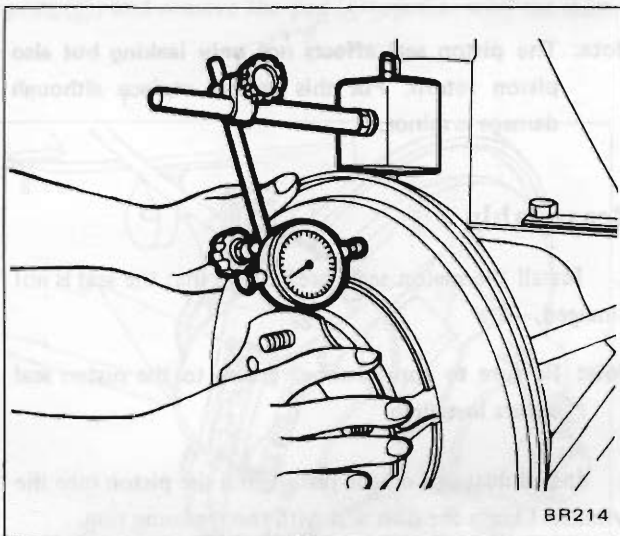

Fig. BR-20 Measuring deflection

### Deflection

Total deflection:

Less than 0.15 mm (0.0059 in)

Wear limit 0.2 mm (0.0079 in)

### 2. Parallelism

Measure thickness toward the entire periphery on the same circumference using a micrometer.

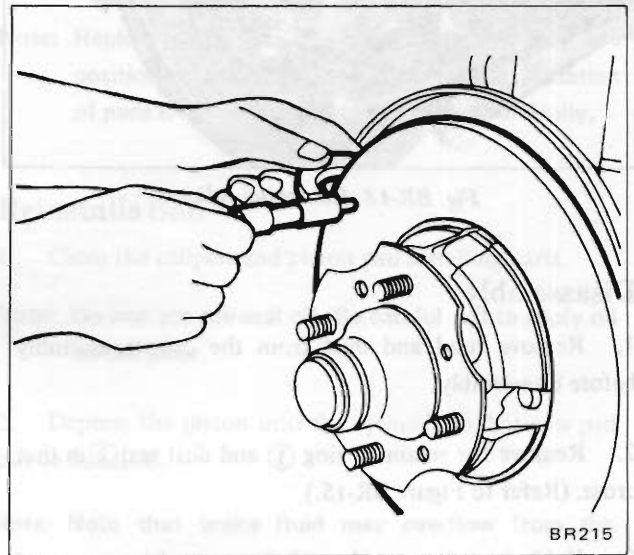

Fig. BR-21 Measuring parallelism

Parallelism (when new):

Less than 0.03 mm (0.0012 in)

Usage limit 0.07 mm (0.0028 in)

### 3. Thickness

If the rotor thickness is out of limit, replace. When correcting thickness, be sure that the thickness after correction does not exceed the limit.

Standard thickness: 12.5 mm (0.492 in)

Wear limit: 10.5 mm (0.414 in)

## ADJUSTING FRONT BRAKE

Ordinarily, adjustment is not required because clearance between pad and rotor is adjusted automatically by elasticity of the piston seal.



# BRAKE

## REAR BRAKE

### CONTENTS

REPLACING BRAKE SHOE .....	BR-14
Removal .....	BR-14
Reinstallation .....	BR-15
DISASSEMBLY AND INSPECTION .....	BR-16

Removal .....	BR-16
Inspection .....	BR-17
Reassembly and reinstallation .....	BR-17
ADJUSTING REAR BRAKE .....	BR-18

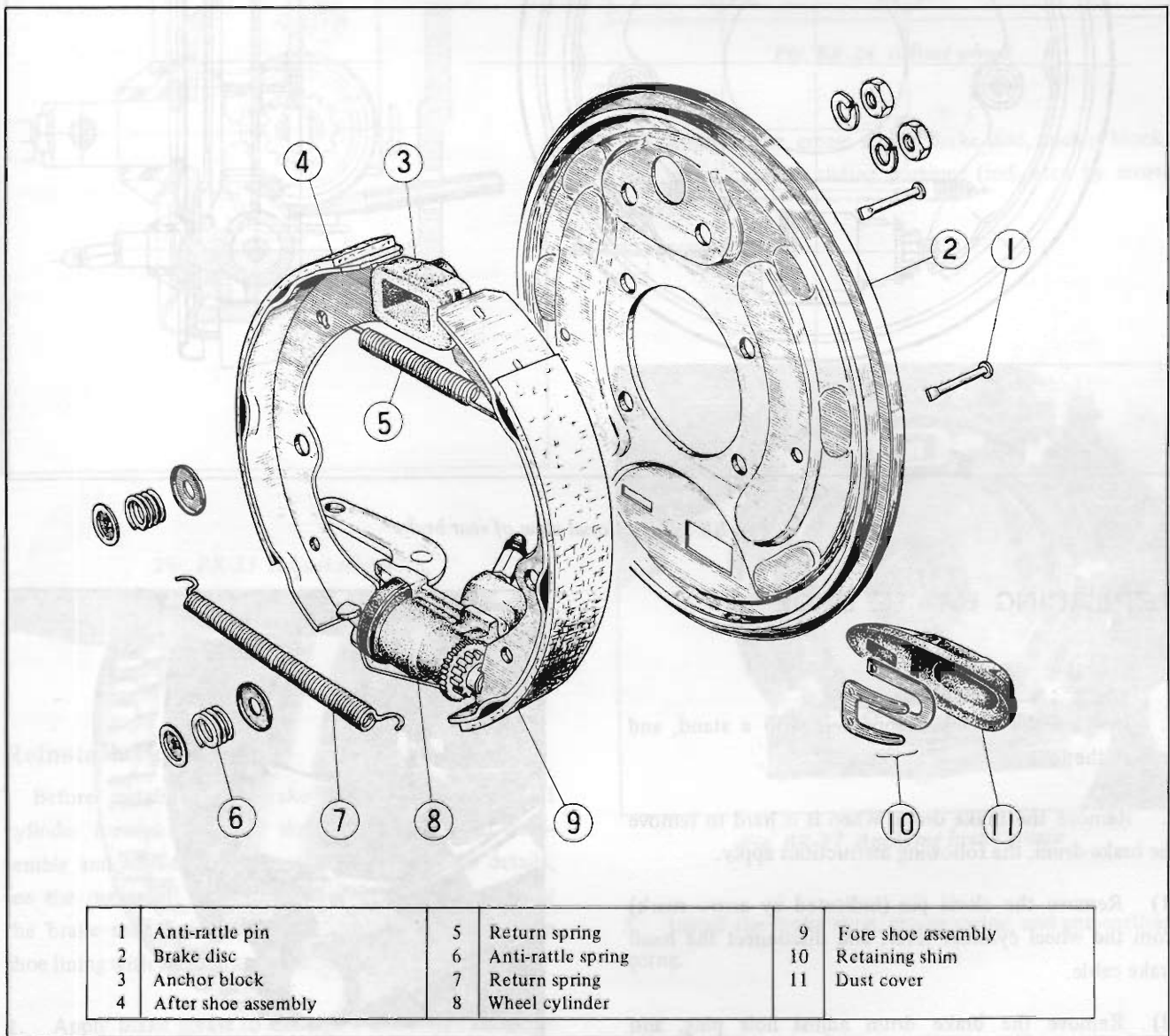

Fig. BR-22 Rear brake

# CHASSIS

The leading-trailing system rear brake adopts sliding system cylinder. When the hand brake is operated, the wheel cylinder lever turns the adjust wheel, and thus,

clearance between the brake shoe and brake drum is adjusted automatically.

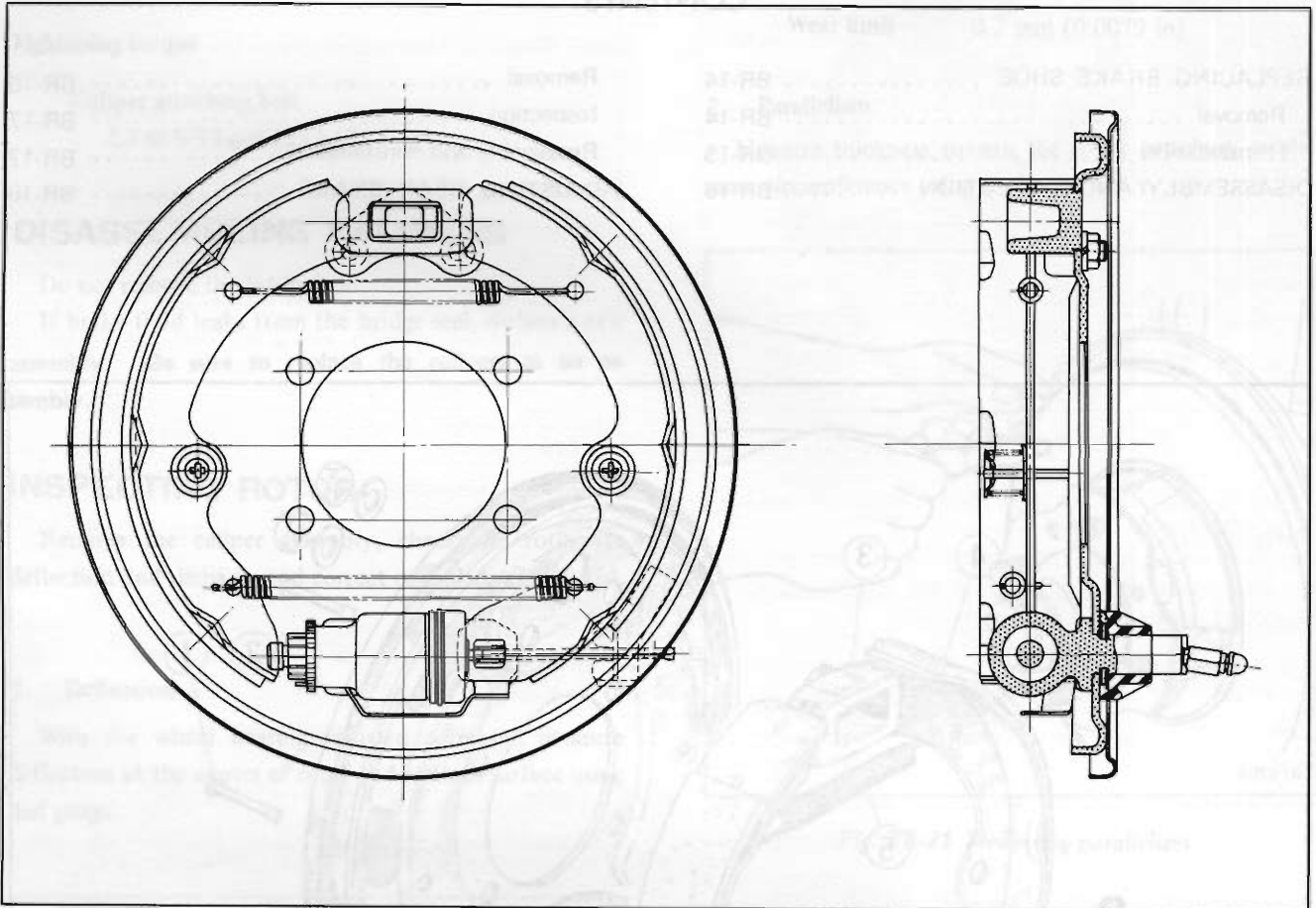

Fig. BR-23 Sectional view of rear brake

## REPLACING BRAKE SHOE

### Removal

1. Jack up the vehicle, support it with a stand, and remove the tire.
2. Remove the brake drum. When it is hard to remove the brake drum, the following instructions apply.
  - (1) Remove the clevis pin (indicated by arrow mark) from the wheel cylinder lever, and disconnect the hand brake cable.
  - (2) Remove the brake drum adjust hole plug, and remove the adjust lever from the adjust wheel with a screwdriver.

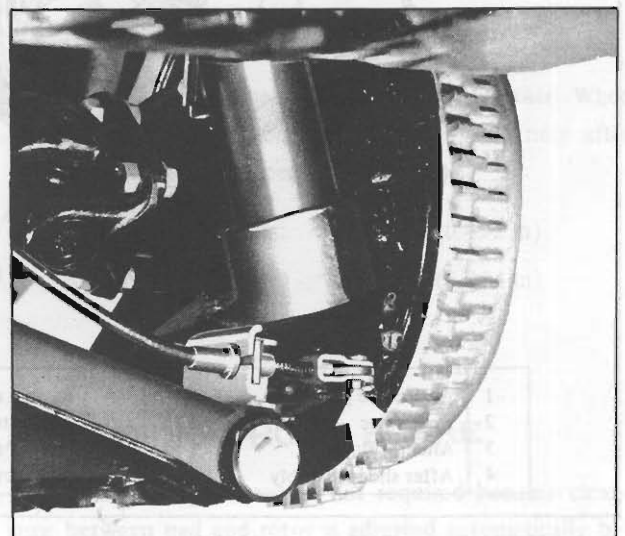
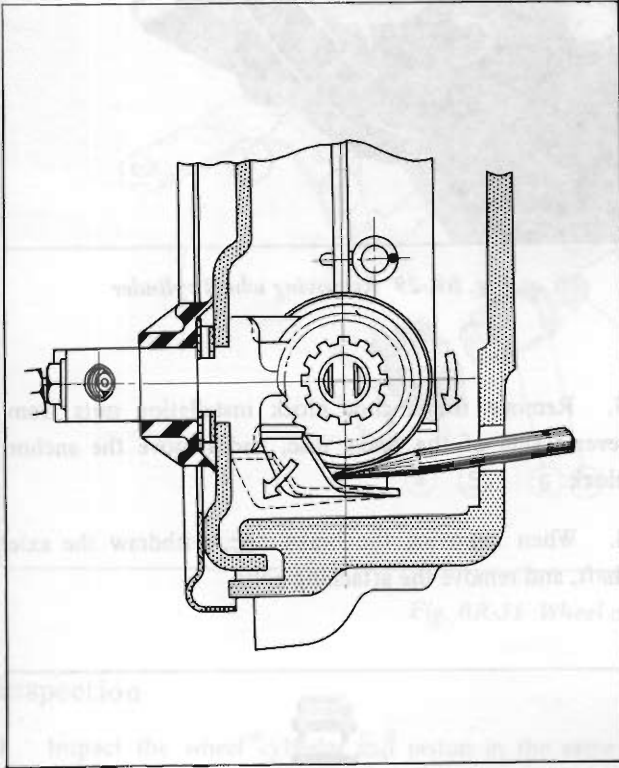

Fig. BR-24 Removing hand brake wire

# BRAKE

(3) Turn the adjust wheel downward with a screwdriver, loosen the brake shoe, and remove the brake drum.

3. Remove the anti-rattling spring, and then remove both brake shoes together.

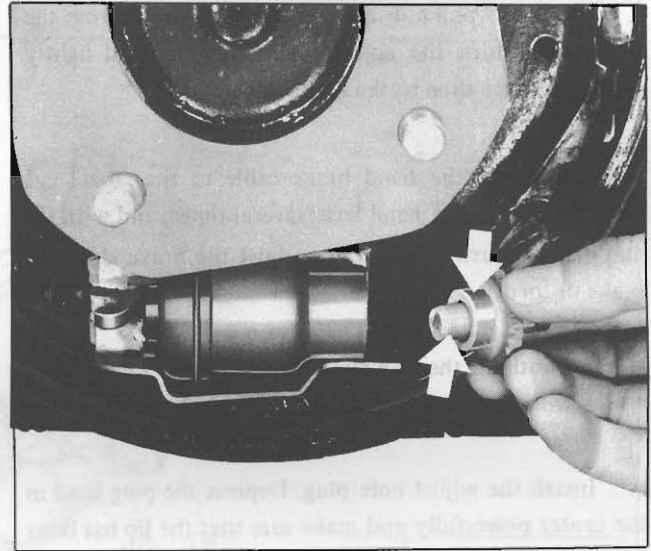

*Fig. BR-25 Adjust wheel*

## Reinstallation

Before installing the brake shoe, check the wheel cylinder for operating and sliding condition, and disassemble and adjust if operation is faulty. For the details, see the paragraph covering disassembly. When replacing the brake shoe lining, be sure to match the new brake shoe lining with the mark on the brake shoe.

1. Apply brake grease to the adjust wheel, and threaded portion and sliding portion (indicated by arrow mark) of the adjust screw sufficiently.



*Fig. BR-26 Adjust wheel*

2. Apply brake grease to the brake disc, anchor block, and wheel cylinder sliding portions (indicated by arrow marks).

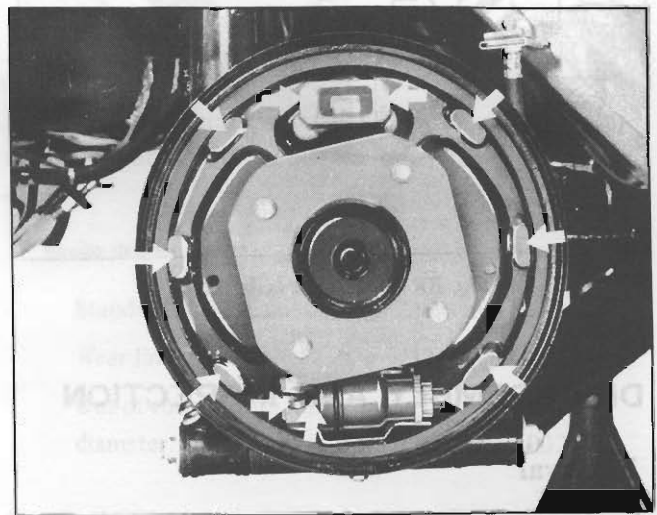

*Fig. BR-27 Applying brake grease*

3. Install the brake shoe, return spring, and anti-rattling spring.

**Note:** Be careful not to allow grease sticking on the brake shoe lining.

## CHASSIS

4. Install the brake drum, insert a screwdriver from the adjust hole, turn the adjust wheel upward, and lightly apply the brake shoe to the brake drum.

5. Reconnect the hand brake cable to the wheel cylinder lever, pull the hand lever several times, and with the automatic adjusting operation, adjust the brake shoe and brake drum clearance.

**Note:** Continue the adjustment until click is eliminated from the adjust wheel claw.

6. Install the adjust hole plug. Depress the plug head in the center powerfully and make sure that the lip has been fitted completely.

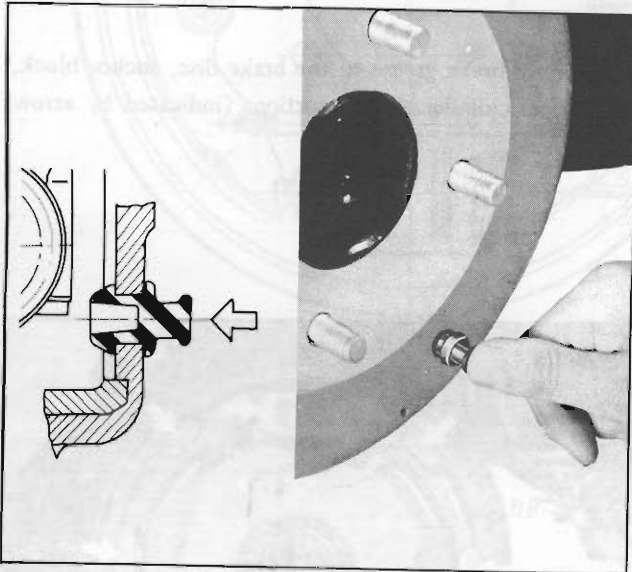

*Fig. BR-28 Adjust hole plug*

### DISASSEMBLY AND INSPECTION

#### Removal

1. Jack up the vehicle, and remove the wheels, brake drum and brake shoe.

**Note:** For the details, refer to the paragraph covering the brake shoe replacement.

2. Remove the brake tube ① and dust cover ②, drive out the lock plate ③ toward the front, withdraw the adjust plate rearward, and remove the wheel cylinder.

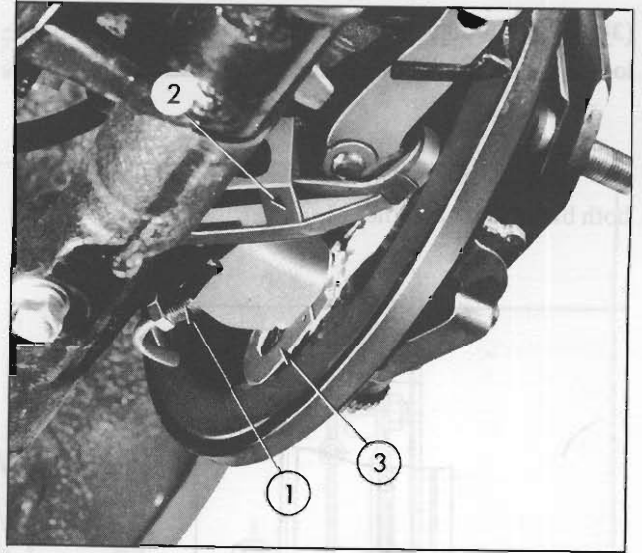

*Fig. BR-29 Removing wheel cylinder*

3. Remove the anchor block installation nuts from reverse side of the brake disc, and remove the anchor block.

4. When removing the brake disc, withdraw the axle shaft, and remove the attaching bolts.

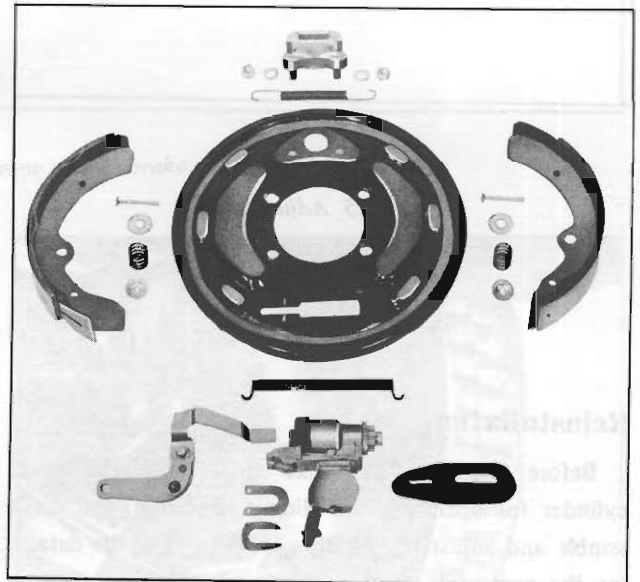

*Fig. BR-30 Rear brake component parts*

5. Disassemble wheel cylinder

Remove the snap ring and dust cover. Withdraw the piston, and remove the adjust wheel and adjust screw.



# BRAKE

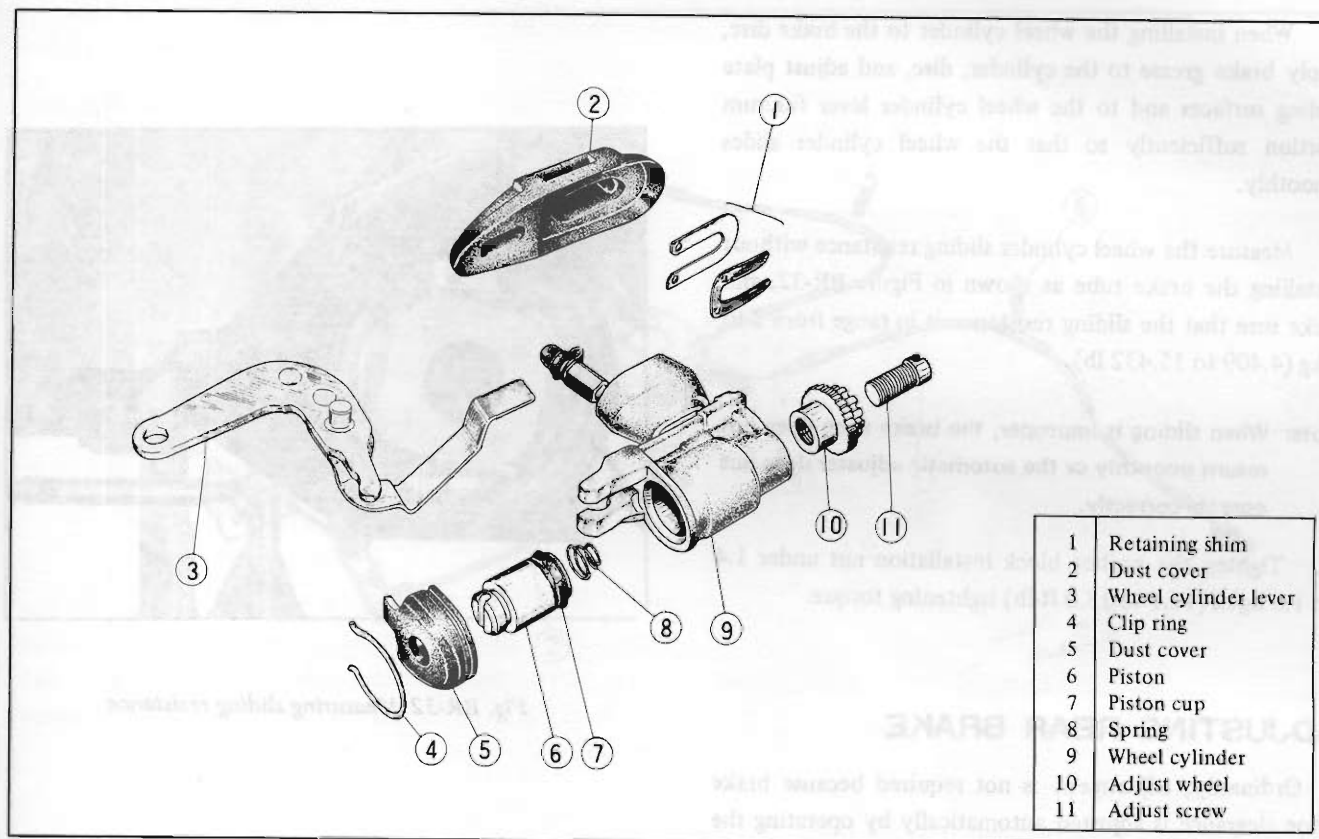

Fig. BR-31 Wheel cylinder component parts

## Inspection

1. Inspect the wheel cylinder and piston in the same manner as for the master cylinder.
2. When the adjust wheel and/or adjust lever is damaged, replace.
3. Check the return spring for wear, damage, breakdown, etc., and replace as required.

### Return spring

	Free length	Coating color
Cylinder side	122 mm (4.73 in)	Black
Anchor block side	120.4 mm (4.67 in)	Green

4. Replace the brake shoe lining if cracked, loosened or unevenly worn. When the brake shoe lining surface is contaminated with grease, oil, etc., clean with carbon tetrachloride or gasoline. When excessively contaminated, replace. When thickness of the brake shoe lining is less

than 1.5 mm (0.0591 in), replace.

5. Check the brake drum, and repair or replace if unevenly worn, worn in step or other faulty condition exists.

### Brake drum

Standard inner diameter:	228.6 mm (8.98 in)
Wear limit:	230.0 mm (9.055 in)
Out-of-round drum inner diameter:	0.05 mm (0.002 in)

6. Replace brake disc and/or other parts, if defective.

## Reassembly and reinstallation

The rear brake is reassembled and reinstalled in reverse sequence of disassembly and removal. However, note the following matters.

1. When assembling the wheel cylinder, be sure to apply rubber grease to the piston cup and other rubber parts slightly.



# CHASSIS

2. When installing the wheel cylinder to the brake disc, apply brake grease to the cylinder, disc, and adjust plate sliding surfaces and to the wheel cylinder lever fulcrum portion sufficiently so that the wheel cylinder slides smoothly.

3. Measure the wheel cylinder sliding resistance without installing the brake tube as shown in Figure BR-32, and make sure that the sliding resistance is in range from 2 to 7 kg (4.409 to 15.432 lb).

**Note:** When sliding is improper, the brake shoe does not return smoothly or the automatic adjuster does not operate correctly.

4. Tighten the anchor block installation nut under 1.4 to 1.8 kg-m (10.1 to 13.0 ft-lb) tightening torque.

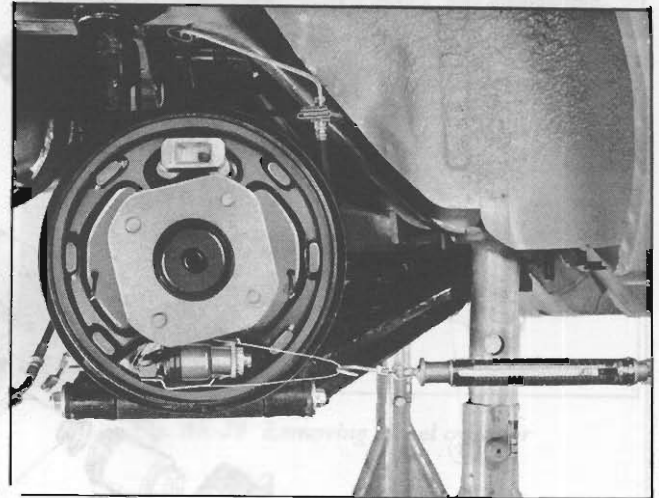

Fig. BR-32 Measuring sliding resistance

## ADJUSTING REAR BRAKE

Ordinarily, adjustment is not required because brake shoe clearance is adjusted automatically by operating the hand brake, as well as the front brake.

## HAND BRAKE

### CONTENTS

Removal .....	BR-19
Inspection .....	BR-20

Reinstallation .....	BR-20
----------------------	-------

The hand brake linkage is in the floor tunnel. Hence, removal and other operations must be done after re-

moving the propeller shaft.

# BRAKE

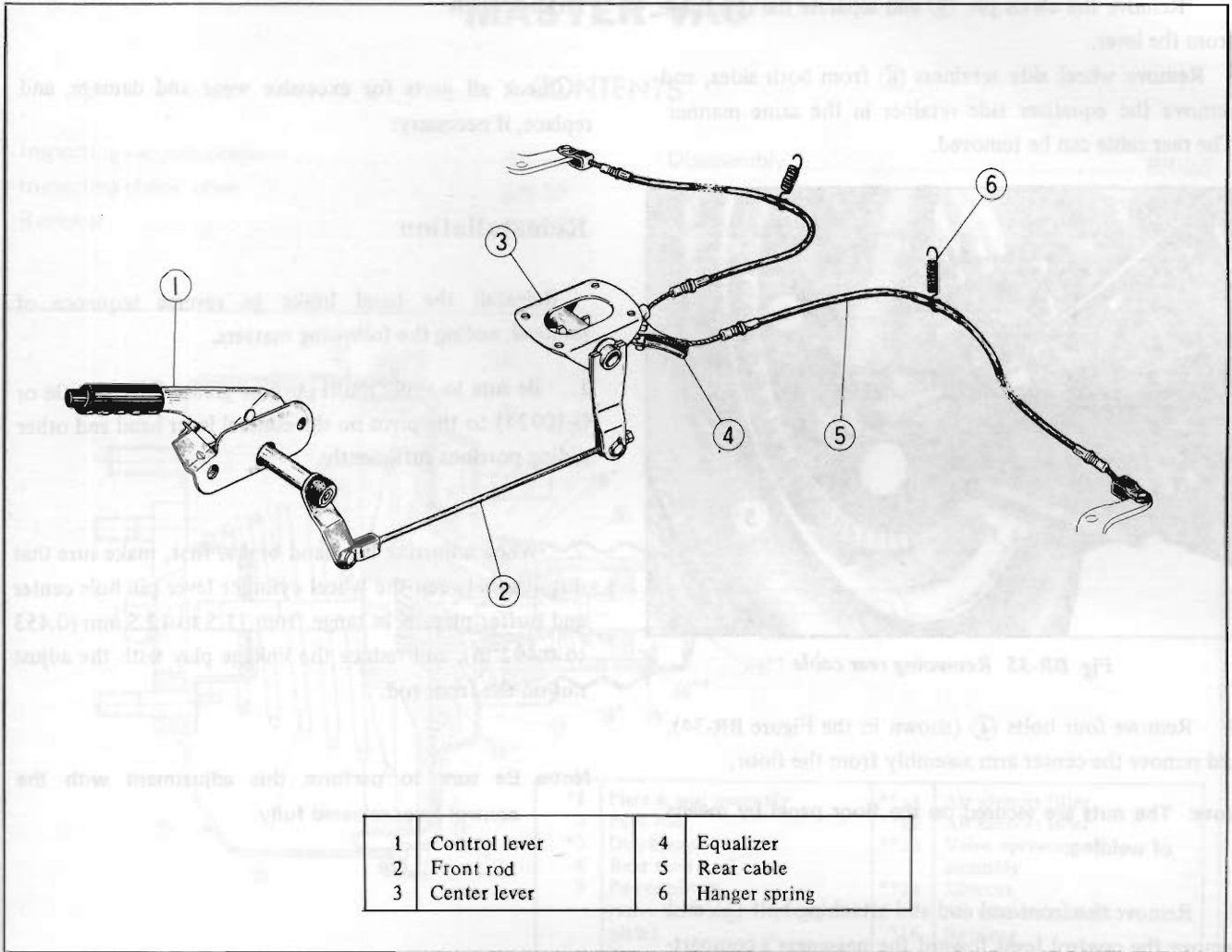

Fig. BR-33 Hand brake linkage

## Removal

1. Remove the lock nut and adjust nut ① from the rear end of the front rod, the clevis pin ② from the front end, and remove the front rod.

2. Remove the hanger spring and clevis pin ③.

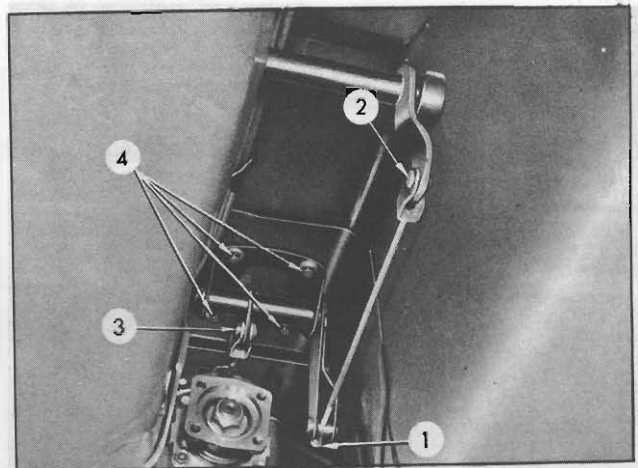

Fig. BR-34 Removal of hand brake

# CHASSIS

3. Remove the clevis pin ⑤ and separate the rear cable from the lever.

Remove wheel side retainers ⑥ from both sides, and remove the equalizer side retainer in the same manner. The rear cable can be removed.

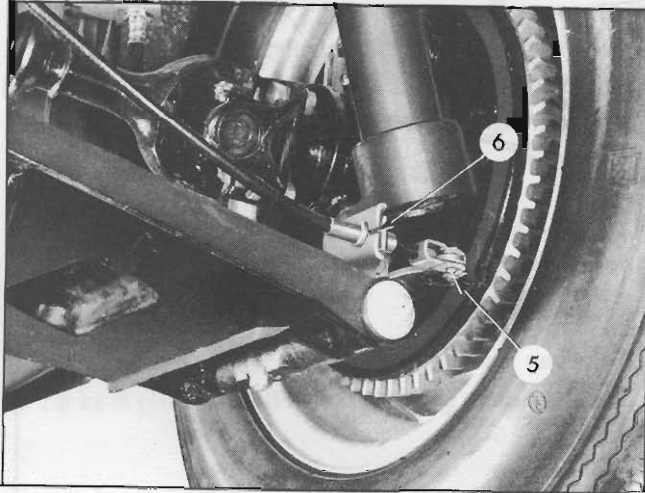

Fig. BR-35 Removing rear cable

4. Remove four bolts ④ (shown in the Figure BR-34), and remove the center arm assembly from the floor.

**Note:** The nuts are secured on the floor panel by means of welding.

5. Remove the front rod end and attaching bolt ①, and remove the control lever toward the passenger's compartment.

**Note:** When removing the control lever, first, remove the right side seat. The boot is secured with four fasteners ②.

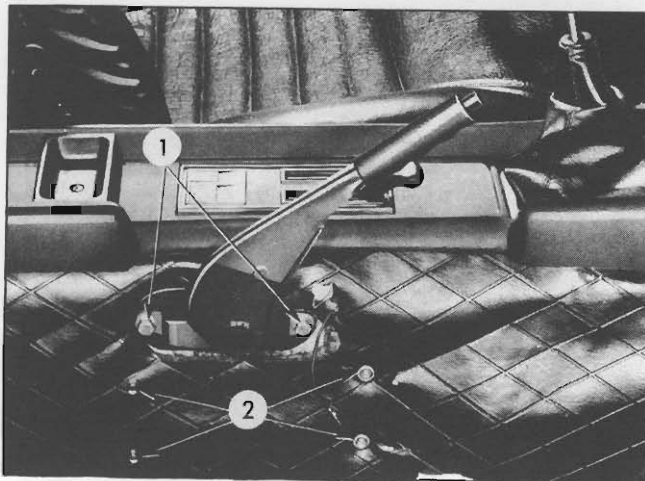

Fig. BR-36 Removing control lever

## Inspection

Check all parts for excessive wear and damage, and replace, if necessary.

## Reinstallation

Reinstall the hand brake in reverse sequence of removal, noting the following matters.

1. Be sure to apply multi-purpose grease (MIL G2108 or G-10924) to the pivot on the control lever head and other sliding portions sufficiently.

2. When adjusting the hand brake, first, make sure that distance between the wheel cylinder lever pin hole center and buffer plate is in range from 11.5 to 12.5 mm (0.453 to 0.492 in), and reduce the linkage play with the adjust nut on the front rod.

**Note:** Be sure to perform this adjustment with the control lever released fully.

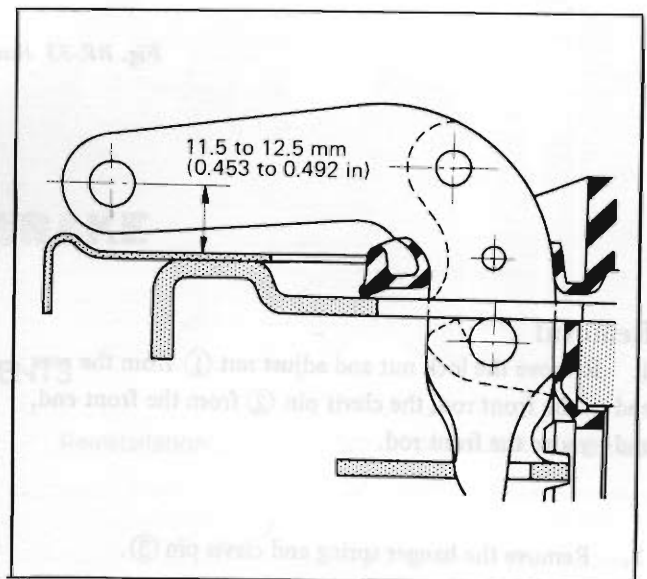

Fig. BR-37 Adjusting hand brake

# BRAKE

## MASTER-VAC

### CONTENTS

Inspecting vacuum pressure .....	BR-22	Disassembly .....	BR-23
Inspecting check valve .....	BR-23	Inspection .....	BR-25
Removal .....	BR-23	Assembly and adjustment .....	BR-25
		Reinstallation .....	BR-26

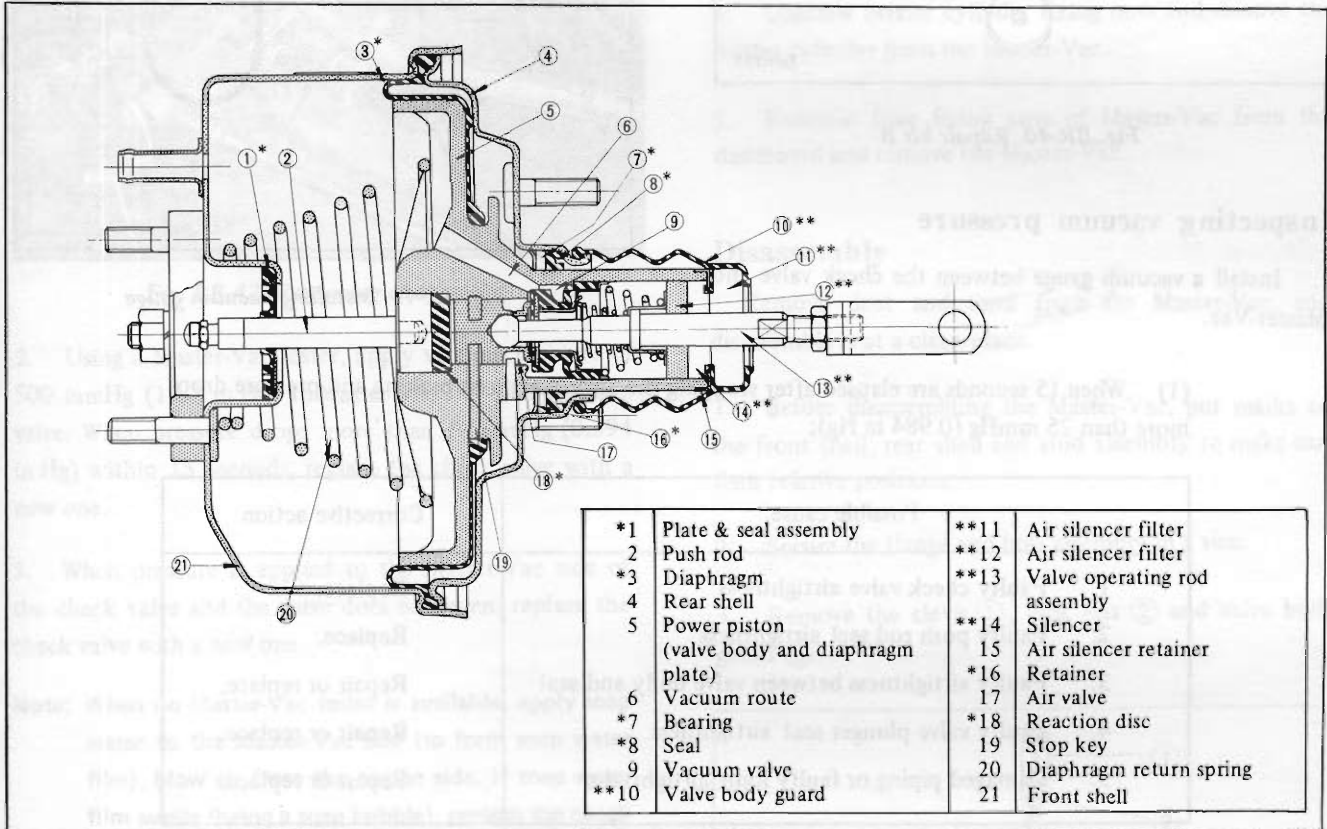

Fig. BR-38 Cross-sectional view of Master-Vac

Overhaul the Master-Vac every two years, replacing those rubber parts accompanied with single asterisk (\*) every two years and those with double asterisks (\*\*) and check valve every four years. The parts required in replacing are available as Master-Vac repair kit.

**Note: Repair Kit A: Parts to be replaced every two years**

**Repair Kit B: Parts to be replaced every four years (including the Kit A)**

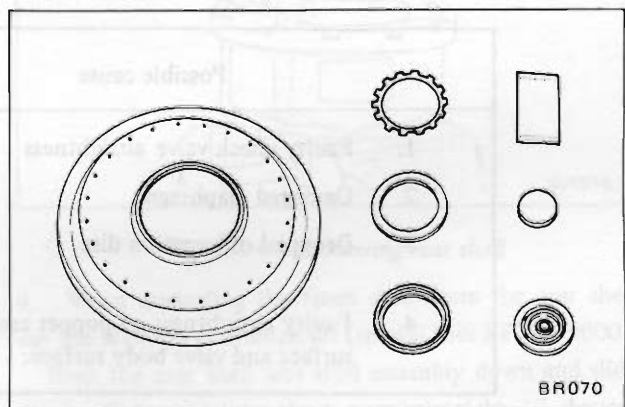

Fig. BR-39 Repair kit A



# CHASSIS

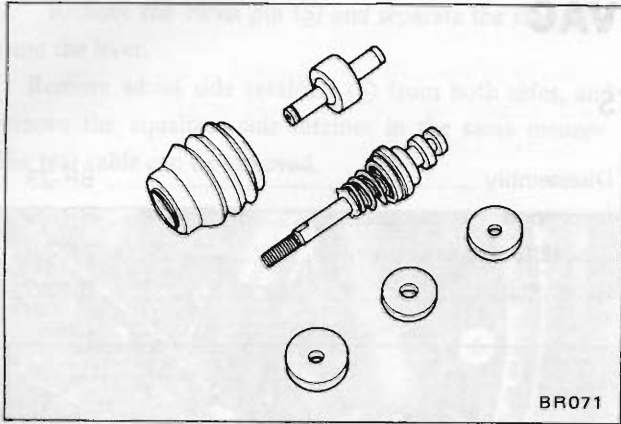

Fig. BR-40 Repair kit B

## Inspecting vacuum pressure

1. Install a vacuum gauge between the check valve and Master-Vac.

2. Increase engine speed, and stop the engine when the vacuum gauge indicates 500 mmHg (19.7 in Hg).

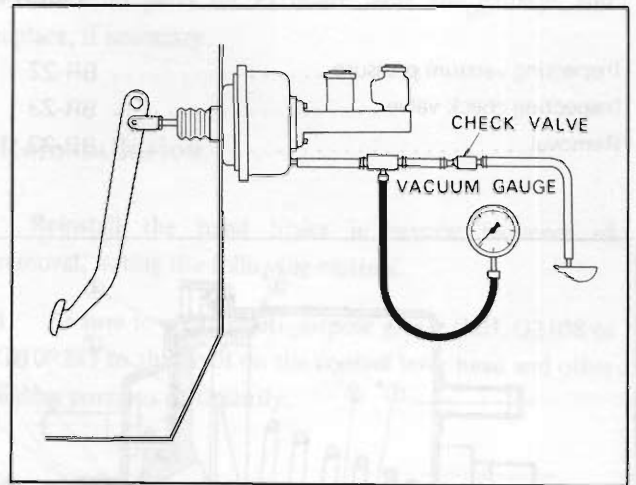

Fig. BR-41 Installing vacuum gauge

(1) When 15 seconds are elapsed after stopping the engine without braking and pressure drops more than 25 mmHg (0.984 in Hg);

Possible cause	Corrective action
1. Faulty check valve airtightness	Replace.
2. Faulty push rod seal airtightness	Replace.
3. Faulty airtightness between valve body and seal	Repair or replace.
4. Faulty valve plunger seat airtightness	Repair or replace.
5. Damaged piping or faulty joint airtightness	Repair or replace.

(2) When 15 seconds are elapsed after stopping the engine by applying full braking force, and pressure drops more than 25 mmHg (0.984 in Hg);

Possible cause	Corrective action
1. Faulty check valve airtightness	Replace.
2. Damaged diaphragm	Replace.
3. Dropped off reaction disc	Reinstall and check the push rod for returning.
4. Faulty airtightness on poppet assembly seat surface and valve body surface.	Repair or replace.

**Note:** When a replacement is required, be sure to replace the Master-Vac as an assembly.



# BRAKE

## Inspecting check valve

1. Remove the clip (indicated by arrow mark) and disconnect the hoses from both ends. The check valve can be removed.

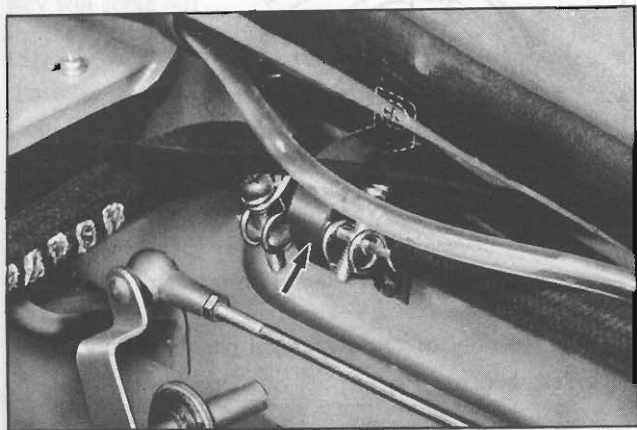

Fig. BR-42 Removing check valve

2. Using a Master-Vac tester, apply vacuum pressure of 500 mmHg (19.7 in Hg) to Master-Vac side of the check valve. When pressure drops more than 10 mmHg (0.394 in Hg) within 15 seconds, replace the check valve with a new one.

3. When pressure is applied to the Master-Vac side of the check valve and the valve does not open, replace the check valve with a new one.

**Note:** When no Master-Vac tester is available, apply soap water to the Master-Vac side (to form soap water film), blow air from the engine side. If soap water film swells (being a soap bubble), replace the check valve with a new one. Subsequently, blow air from the Master-Vac side, and if the check valve does not open, replace.

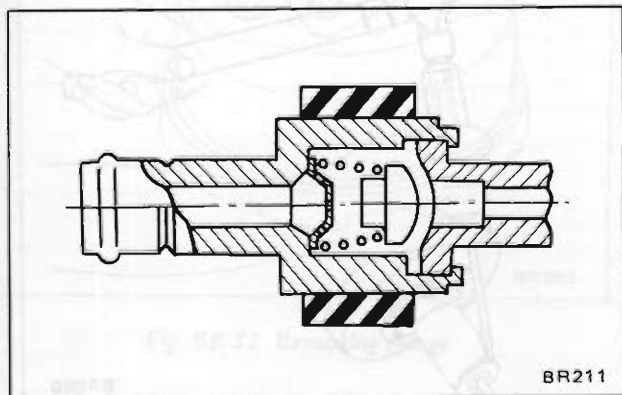

Fig. BR-43 Cross-sectional view of check valve

## Removal

1. Remove the clevis pin from the push rod connected with the brake pedal, and disengage the Master-Vac from the brake pedal.
2. Disconnect the brake tube from the master cylinder.
3. Disconnect the vacuum hose from the Master-Vac.
4. Unscrew master cylinder fixing nuts and remove the master cylinder from the Master-Vac.
5. Unscrew four fixing nuts of Master-Vac from the dashboard and remove the Master-Vac.

## Disassembly

Remove dust and mud from the Master-Vac, and disassemble it at a clean place.

1. Before disassembling the Master-Vac, put marks on the front shell, rear shell and stud assembly to make sure their relative positions.
2. Secure the flange and bolt assembly in a vise.
3. Remove the clevis ①, lock nut ② and valve body guard ③.

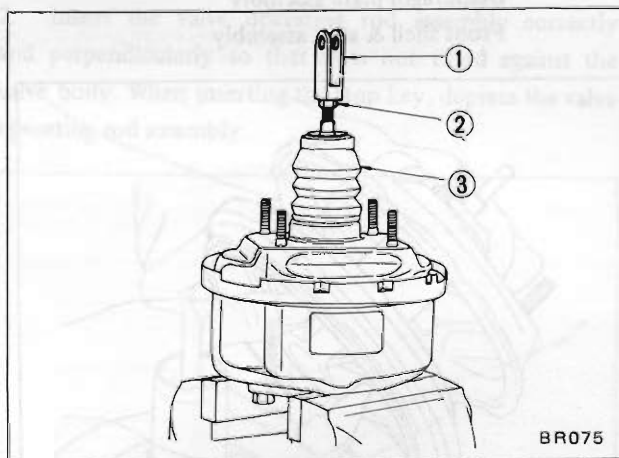

Fig. BR-44 Removing rear shell

4. When separating the front shell from the rear shell use the Master-Vac wrench set (special tool ST08050000). Push the rear shell and stud assembly down and slide them off by rotating them approximately 17 degrees counterclockwise.

# CHASSIS

Note: When the valve body and diaphragm plate are detached together with the rear shell and stud assembly from the front shell, be careful not to drop them while disassembling the Master-Vac.

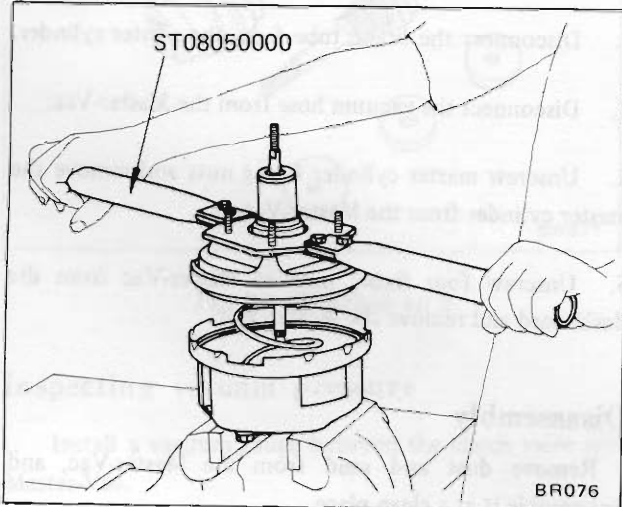

Fig. BR-45 Removing rear shell

5. Remove the push rod from the diaphragm plate.
6. Detach the valve body and diaphragm from the rear shell and stud assembly. Then the Master-Vac is disassembled in three subassemblies as shown below:

Rear shell & seal assembly  
 Diaphragm plate assembly  
 Front shell & stud assembly

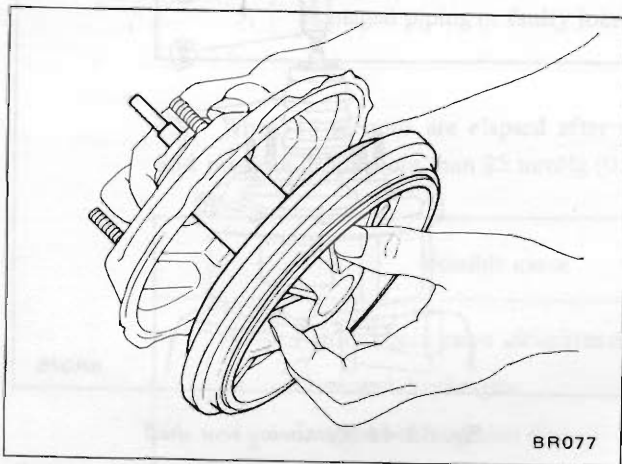

Fig. BR-46 Removing valve body

7. Disassembly of rear shell and seal assembly. Remove the retainer using a screwdriver and detach the bearing and seal.

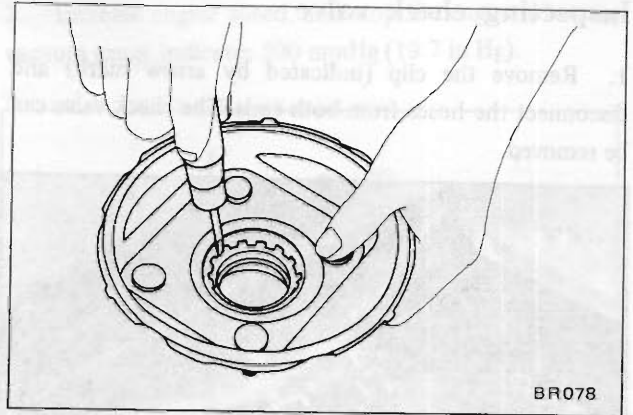

Fig. BR-47 Removing retainer

8. Disassembly of the diaphragm plate assembly. Work on a clean bench.

- (1) Pull out the diaphragm from the groove of the diaphragm plate.

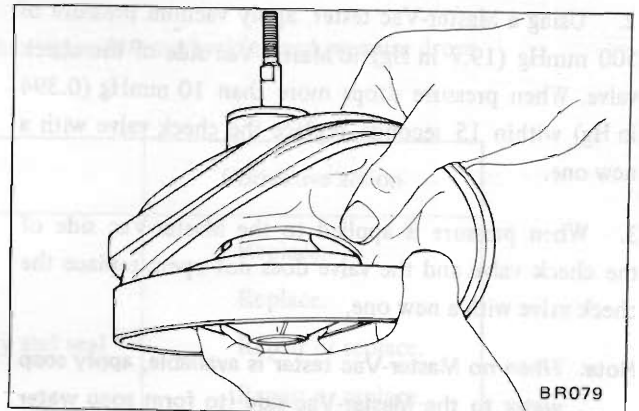

Fig. BR-48 Pulling out diaphragm

- (2) Remove the air silencer retainer by tapping the periphery with a screwdriver and a hammer lightly and evenly.

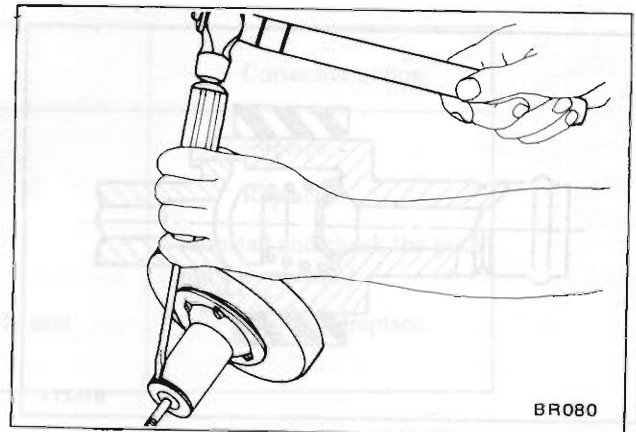

Fig. BR-49 Removing air silencer retainer

# BRAKE

**Note:** Do not tap rapidly, otherwise the valve body may be cracked.

(3) Depress the valve operating rod, face the key hole downward, and give a vibration. The valve plunger stop key will come out.

(4) After removing the valve plunger stop key, detach the valve operating rod assembly, and the air silencer filter from the valve body and diaphragm plate.

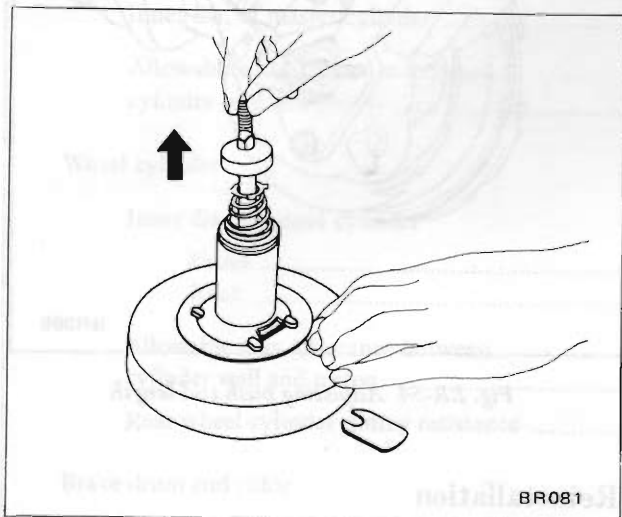

Fig. BR-50 Removing valve operating rod assembly

(5) Push out the reaction disc from the valve body side.

9. Disassembly of the front shell and stud assembly.

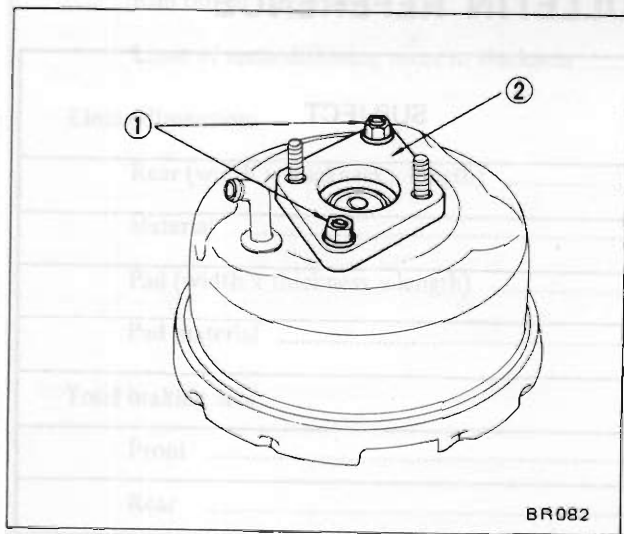

Fig. BR-51 Removing flange

(1) Remove the nut ① and flange ②.

(2) Remove the plate and seal assembly.

## Inspection

1. Check the poppet assembly.

If wear or abnormal conditions are found, replace it as a valve operating rod assembly.

2. Check components.

If abnormal conditions are found, replace them with new ones.

## Assembly and adjustment

Assemble in reverse sequence of disassembly.

1. Apply silicon grease thinly to the following:

- Seal: lip and face contacting with the rear shell and seal assembly.
- Poppet: lip
- Reaction disc: both faces
- Diaphragm: edge contacting with front and rear shells
- Plate and seal assembly: face contacting with the front shell and the push rod
- Push rod: face contacting with the diaphragm plate

**Note:** Grease is contained in the repair kit.

2. Insert the valve operating rod assembly correctly and perpendicularly so that it is not tilted against the valve body. When inserting the stop key, depress the valve operating rod assembly.

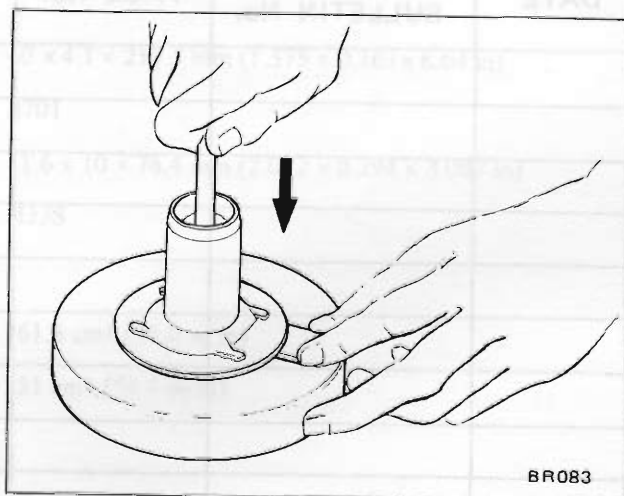

Fig. BR-52 Inserting stop key

# CHASSIS

3. When installing the retainer on the rear shell, use the press fit tool (special tool ST08060000) and fit it completely down to such an extent that the tool flange surface comes into contact with the bottom.

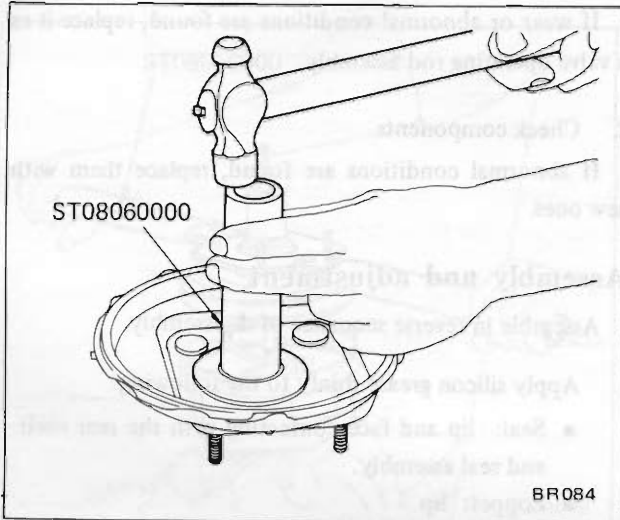

Fig. BR-53 Fitting retainer

4. Upon completion of the assembly, adjust push rod end height so that depth from the flange surface to the push rod end is 3.5 to 4.0 mm (0.1377 to 0.1575 in).

**Note:** When adjusting the depth, face the push rod end upward so that the reaction disc is not dropped off into the master vac.

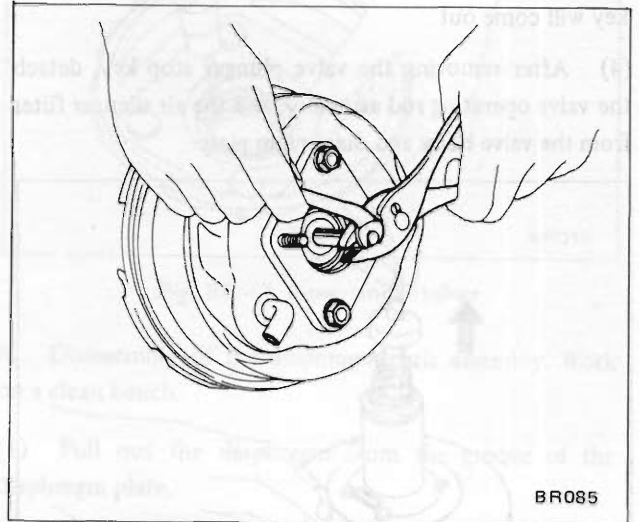

Fig. BR-54 Adjusting push rod length

## Reinstallation

Reinstallation is reverse sequence of removal.

## SERVICE JOURNAL OR BULLETIN REFERENCE

DATE	JOURNAL or BULLETIN No.	PAGE No.	SUBJECT



## BRAKE

### SERVICE DATA AND SPECIFICATIONS

#### Brake pedal

Pedal free height ..... 203 mm (8.05 in)

Full stroke of pedal head ..... 140 mm (5.51 in)

#### Master cylinder

Inner dia. of master cylinder ..... 22.22 mm (7/8 in)

Allowable max. clearance between  
cylinder wall and piston ..... 0.15 mm (0.006 in)

#### Wheel cylinder

##### Inner dia. of wheel cylinder

Front ..... 53.98 mm (2 1/8 in)

Rear ..... 22.22 mm (7/8 in)

Allowable max. clearance between  
cylinder wall and piston ..... 0.15 mm (0.0059 in)

Rear wheel cylinder sliding resistance ..... 2 to 7 kg (4.4 to 15.4 lb)

#### Brake drum and rotor

Rear brake drum inner dia. .... 228.6 mm (9 in)

Front brake rotor outer dia. .... 271 mm (10.67 in)

Drum inside out-of-round ..... less than 0.05 mm (0.0020 in)

Limit of reconditioning drum in dia. .... 230.0 mm (9.055 in)

Run out of the rotor ..... less than 0.15 mm (0.0059 in)

Limit of reconditioning rotor in thickness ..... 10.5 mm (0.413 in)

#### Lining dimensions

Rear (width × thickness × length) ..... 40 × 4.1 × 219.5 mm (1.575 × 0.161 × 8.64 in)

Material ..... B701

Pad (width × thickness × length) ..... 51.6 × 10 × 78.4 mm (2.032 × 0.394 × 3.087 in)

Pad material ..... M33S

#### Total braking area

Front ..... 161.6 cm<sup>2</sup> (25.0 sq in)

Rear ..... 351 cm<sup>2</sup> (54.4 sq in)

#### Tightening torque

Fulcrum pin of brake pedal ..... 3.5 to 4.0 kg-m (25.3 to 28.9 ft-lb)



## CHASSIS

Connection of brake tube .....	1.5 to 1.8 kg-m (10.9 to 13.0 ft-lb)
Rotor fixing bolts .....	3.9 to 5.3 kg-m (28.2 to 38.3 ft-lb)
Caliper to knuckle flange .....	7.3 to 9.9 kg-m (52.8 to 71.6 ft-lb)
Disc to bearing housing .....	2.7 to 3.7 kg-m (19.5 to 26.8 ft-lb)
Anchor block installation nut .....	1.4 to 2.1 kg-m (10.1 to 15.2 ft-lb)
Master cylinder stopper screw .....	0.4 to 0.5 kg-m (2.9 to 3.6 ft-lb)
Valve cap .....	8 to 9 kg-m (57.9 to 65.1 ft-lb)
Spindle nut .....	2.5 to 3.0 kg-m (18.1 to 21.7 ft-lb)

## TROUBLE DIAGNOSES AND CORRECTIONS

Troubles	Possible causes	Corrective action
Locked brake pedal	Swollen master cylinder seals due to poor fluid quality or contamination by kerosene, gasoline or mineral oil.	Flush the system, replace all rubber parts, refill with new fluid and air bleed the lines.
	Pistons or valve carrier locked by deposits of fluid, foreign matter, etc.	Clean and bleed the system.
	Seized master cylinder piston due to infiltrations of water through rear end due to defective boot or seals.	Service the master cylinder, replace the piston and the boot and/or seals, to prevent water infiltration.
	Seized pedal shaft.	Smooth bushings, or if other sliding parts are damaged to a remarkable extent, replace them and lubricate.
	Clogged transfer port.	Disassemble and clean master cylinder.
	No compensation takes place. Weak return spring.	Replace defective spring.

## BRAKE

<p>Spongy pedal</p>	<p>Air in brake system because of imperfect bleeding.</p> <p>Swollen hose due to deterioration.</p> <p>Hose swells under fluid pressure due to poor hose quality.</p> <p>Use of a poor quality brake fluid (boiling point of which is too low).</p> <p>Clogged reservoir filler cap vent hole. This promotes a vacuum in master cylinder that sucks air through rear seal.</p>	<p>Bleed thoroughly.</p> <p>Replace the hose and bleed the system.</p> <p>Fit new hoses and bleed the system.</p> <p>Replace the fluid with the specified brake fluid and bleed the system.</p> <p>Clean reservoir filler cap and bleed the system.</p>
<p>Pedal yields under slight pressure</p>	<p>Deteriorated check valve.</p> <p>Fluid leaks through connection.</p> <p>Fluid leaks at wheel cylinders.</p> <p>Fluid leaks through hoses.</p> <p>Low fluid level in reservoir.</p>	<p>Fit a new check valve, make sure that there are no burrs, roughness or blow holes in master cylinder, and bleed the system.</p> <p>Tighten connections, and if necessary, replace faulty parts. Bleed the system.</p> <p>Replace the seals and packings being damaged. Wipe and clean brake shoe linings.</p> <p>Replace the damaged hose, and bleed the system.</p> <p>Add specified fluid up to correct level.</p>
<p>Poor pedal reserve</p>	<p>Master cylinder relief port clogged with foreign matter.</p> <p>System has not been bled.</p> <p>Excessive clearance between shoes and drum.</p>	<p>Clean and bleed the system.</p> <p>Bleed the system.</p> <p>Adjust auto-adjuster operation.</p>
<p>Excessive pedal reserve</p>	<p>Fluid level in reservoir is too low.</p> <p>Deteriorated rubber seals in master cylinder or in wheel cylinders.</p> <p>Excessively swollen hoses due to poor hose quality.</p> <p>Thermal expansion of drums due to excessive overheating.</p>	<p>Top up with specified brake fluid, bleed the system, if required.</p> <p>Replace seals and bleed the system.</p> <p>Replace by designated hoses and bleed the system.</p> <p>Allow drums to cool off. Check brake shoe linings and drums. Replace damaged parts.</p>
<p>Brake locked after pedal return</p>	<p>Worn or broken return spring.</p>	<p>Replace defective springs.</p>

## CHASSIS

	<p>Improper brake shoe return.</p> <p>Clogged master cylinder relief port.</p> <p>Swollen or stuck rubber seals due to contamination by kerosene, mineral oil, gasoline, etc.</p>	<p>Grease brake shoe and wheel cylinder sliding surface.</p> <p>Clean and bleed the system.</p> <p>Flush the system, replace all rubber parts, refill with new brake fluid and bleed the system.</p>
Unbalanced brakes	<p>Fluid leakage at one wheel cylinder only.</p> <p>Rusted or corroded edges of a wheel cylinder.</p> <p>Seized piston in wheel cylinder or caliper assembly.</p> <p>Hose obstructed due to swollen or clogged inner lining.</p> <p>Obstructed flow in metal pipe due to crushing or clogging (if the brakes on one axle are excluded, weak braking may result).</p> <p>Faulty seals at one half caliper.</p>	<p>Wipe, clean or replace the brake shoe linings or lining pads, service the wheel cylinder and bleed the system.</p> <p>Eliminate rust and replace the boots.</p> <p>Service the wheel cylinder, replace the rear wheel cylinder piston or caliper assembly and bleed the system.</p> <p>Replace or clean the hose and bleed the system.</p> <p>Replace or clean the pipe and bleed the system.</p> <p>Take down and strip the half caliper, replace seals and dust covers.</p>
Brake linings dragging all the time on drums or brake discs	<p>Insufficient shoe-to-drum clearance.</p> <p>Weak shoe return springs.</p> <p>Brake pedal has no free travel.</p> <p>Seized master cylinder piston.</p> <p>Master cylinder flooded due to clogged relief port.</p> <p>Brake disc run-out.</p>	<p>Adjust clearance.</p> <p>Replace the springs.</p> <p>Set the push rod length as prescribed.</p> <p>Service the master cylinder, replace the piston and bleed the system.</p> <p>Service the master cylinder, replace the check valve if deteriorated, clean the relief port and bleed the system.</p> <p>Check brake disc for run-out, and replace defective parts, if necessary.</p>
Weak brakes	<p>Fluid leakage from wheel cylinders.</p> <p>Fluid leakage from caliper cylinders.</p>	<p>Wipe and clean the brake shoe linings, service the wheel cylinder replacing damaged parts, and bleed the system.</p> <p>Take down and strip the calipers; replace all rubber seals and clean lining pads.</p>





