

SERVICE MANUAL

DATSUN 240Z SPORTS
MODEL S30 SERIES
CHASSIS & BODY



NISSAN MOTOR CO., LTD.
TOKYO, JAPAN

SECTION BF

BODY

BODY	BF- 1
FRONT END AND FRONT FENDER	BF- 4
HOOD	BF- 6
WINDSHIELD GLASS	BF- 7
DOOR	BF-10
TAIL GATE	BF-20
REAR PANEL FINISHER	BF-23
INSTRUMENT PANEL	BF-25
SEAT	BF-26
INTERIOR TRIMS	BF-28

BF

BODY

BODY

Description

The body adopts a unit construction system. With construction, the weight has been reduced to a minimum and rigidity and safety have been highly improved. In order to utilize the rider's compartment effectively, the fuel tank is located beneath the floor and a spare tire is

contained in the spare tire housing sunk below the floor level. Thus, flat floor space behind the seats is largely provided for luggages. In addition, the rear of the body is provided with a large tail gate.

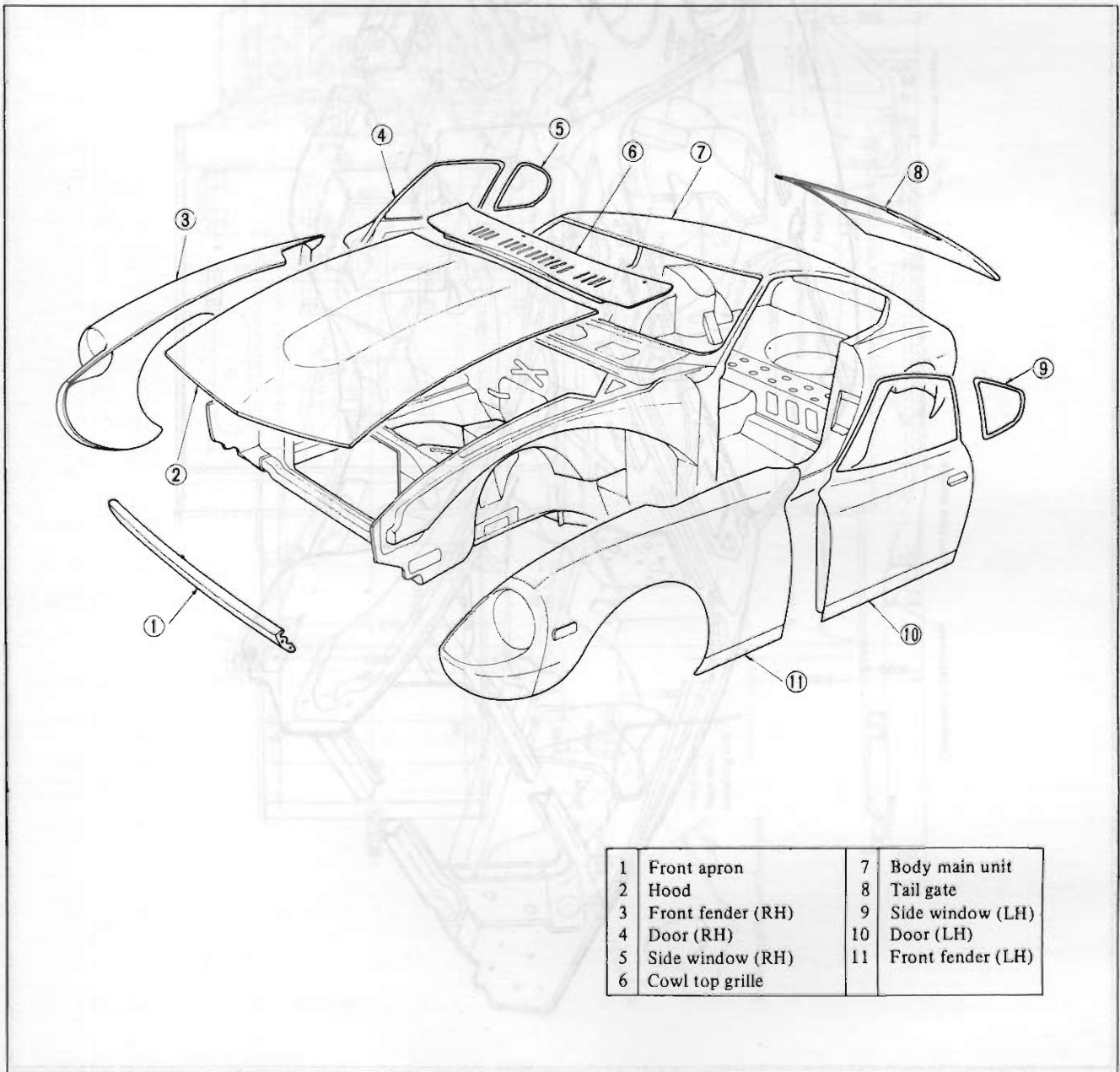

Fig. BF-1 Body structure

BODY

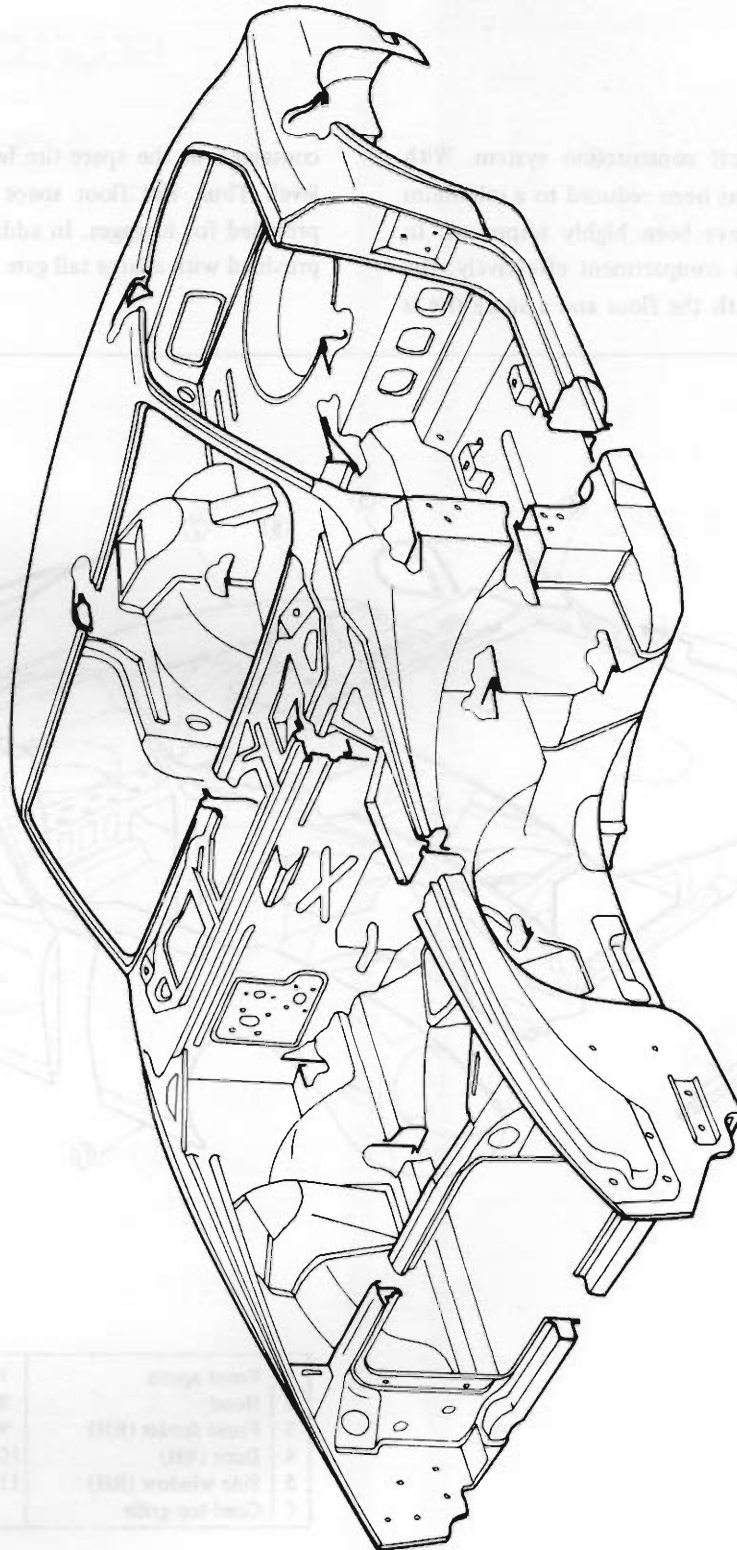

Fig. BF-2 Outline of body

BODY

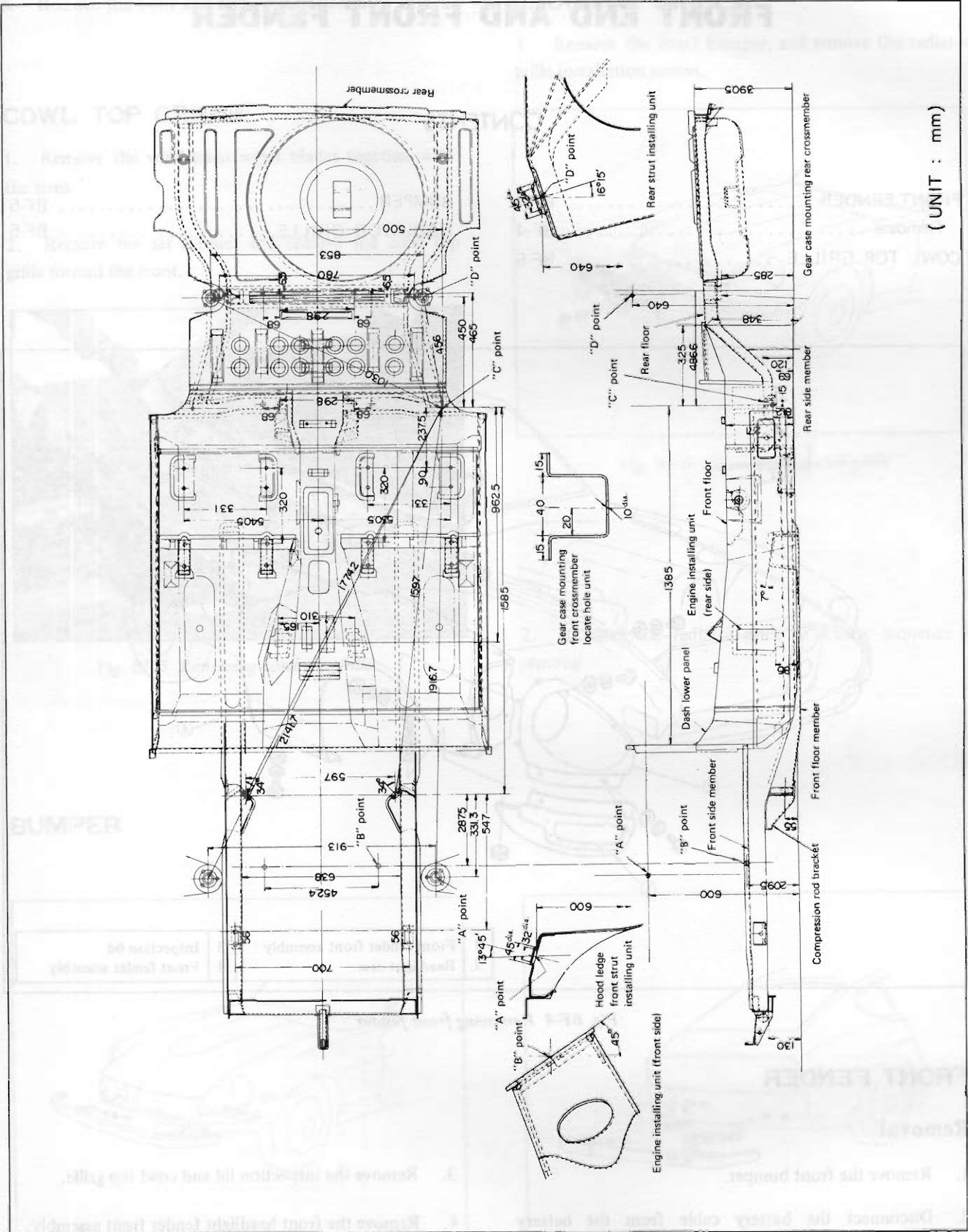

Fig. BE-3 Standard body dimensions

FRONT END AND FRONT FENDER

CONTENTS

FRONT FENDER	BF-4	BUMPER	BF-5
Removal	BF-4	RADIATOR GRILLE	BF-5
COWL TOP GRILLE	BF-5		

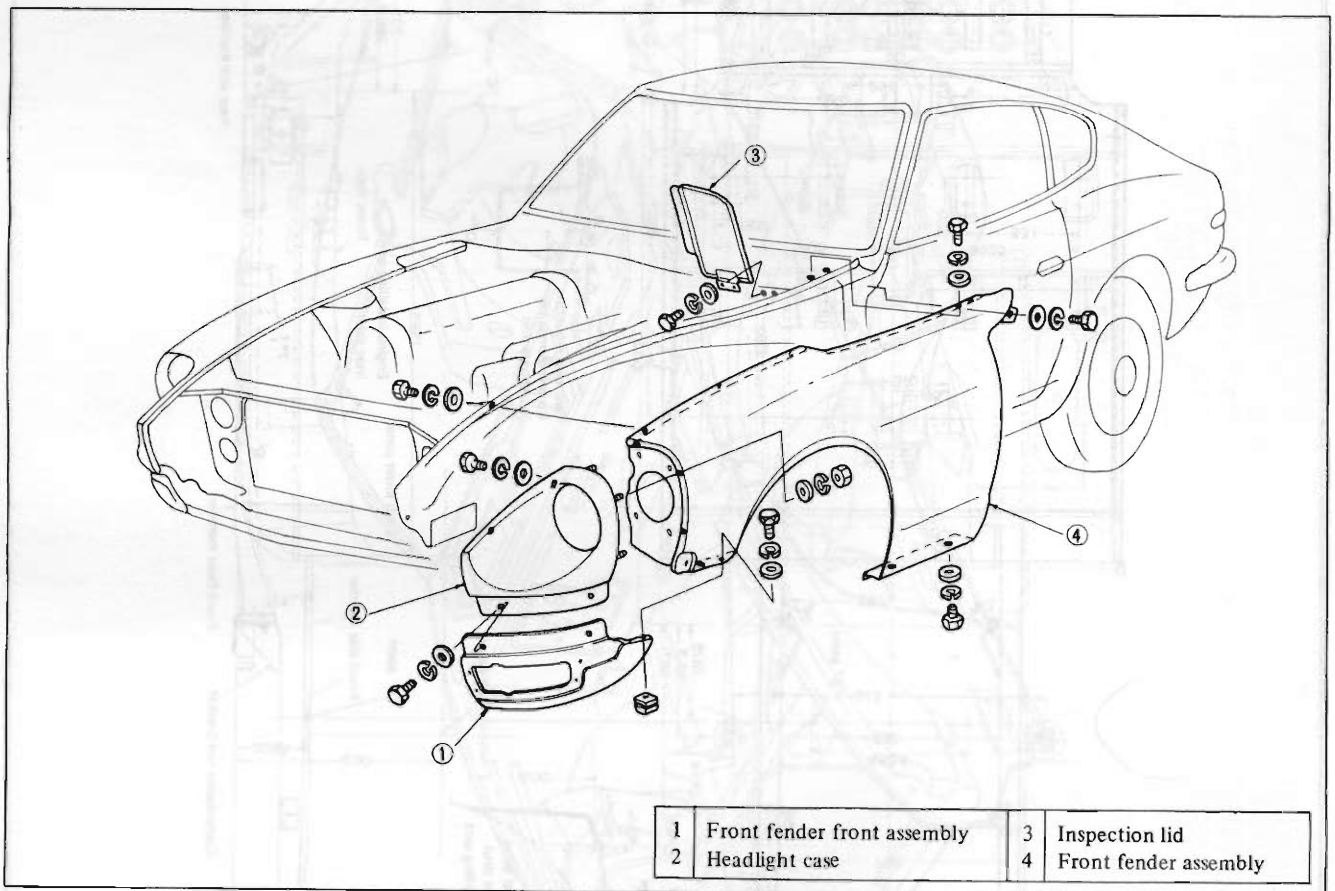

Fig. BF-4 Removing front fender

FRONT FENDER

Removal

1. Remove the front bumper.
2. Disconnect the battery cable from the battery terminal, and remove the headlights and side flasher lamps.
3. Remove the inspection lid and cowl top grille.
4. Remove the front headlight fender front assembly.
5. Remove the headlight cases.

BODY

6. Remove the bolts and nuts used to clamp the fender.

COWL TOP GRILLE

1. Remove the windshield wiper blades together with the arms.
2. Remove the set screws, and remove the cowl top grille toward the front.

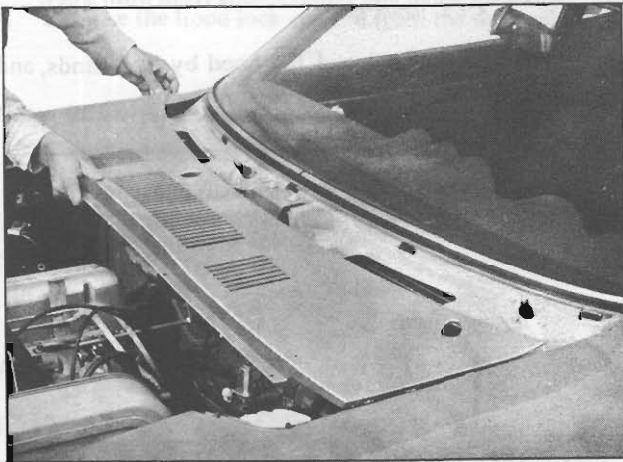

Fig. BF-5 Removing cowl top grille

RADIATOR GRILLE

1. Remove the front bumper, and remove the radiator grille installation screws.

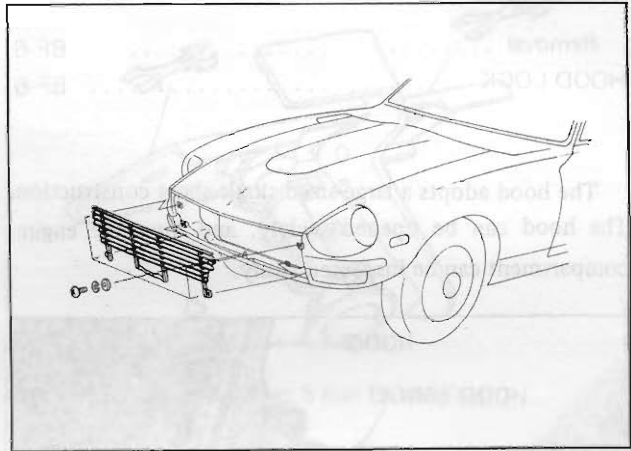

Fig. BF-6 Removing radiator grille

2. Reinstall the radiator grille in reverse sequence of removal.

BUMPER

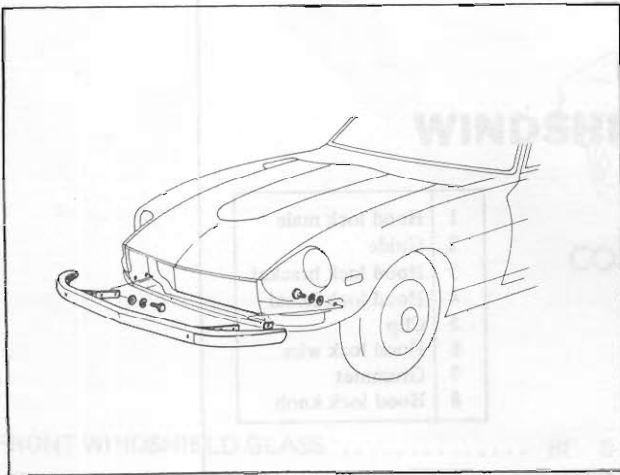

Fig. BF-7 Removing front bumper

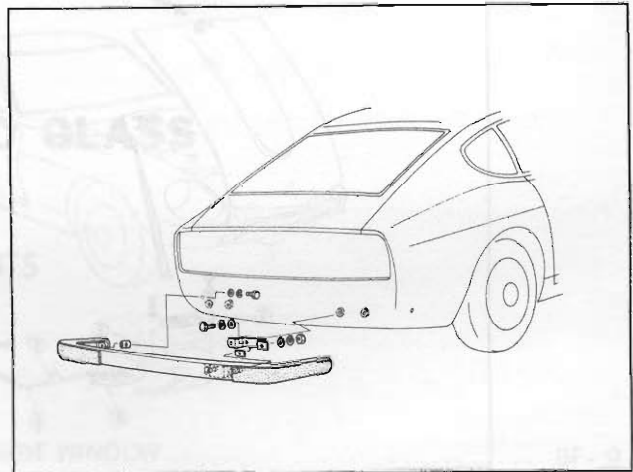

Fig. BF-8 Removing rear bumper

BODY

HOOD

CONTENTS

Removal	BF-6
HOOD LOCK	BF-6

Removal	BF-7
Adjustment	BF-7

The hood adopts a large-sized single sheet construction. The hood can be opened widely, and thus, the engine compartment can be inspected easily.

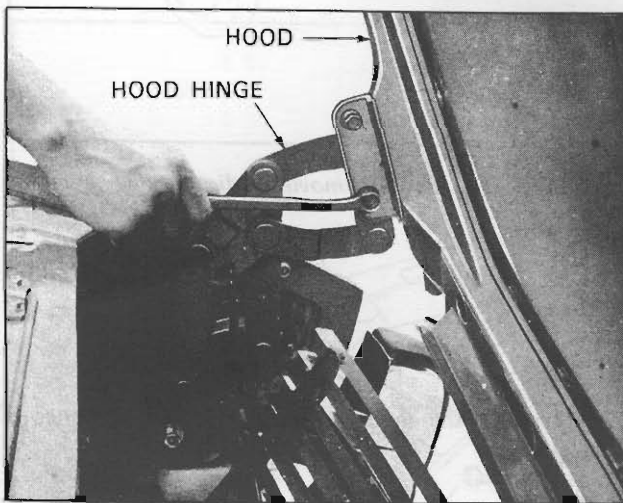

Fig. BF-9 Removing hood

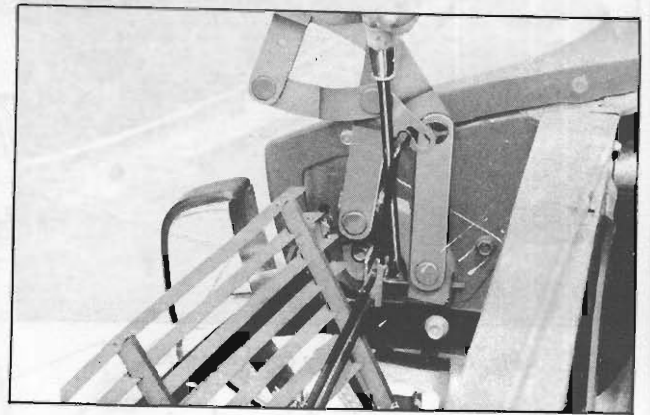

Fig. BF-10 Removing hood torsion bar

HOOD LOCK

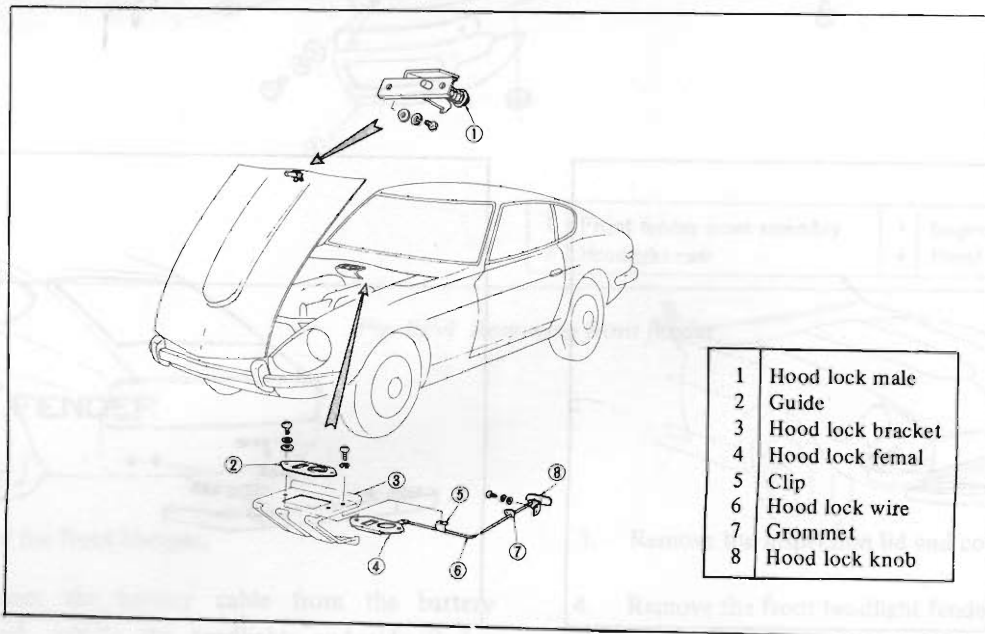

Fig. BF-11 Structural view of hood lock

BODY

Removal

1. Open the hood, and remove the hood lock male.
2. Remove the clamp from the hood lock bracket, and remove the ball caulked on the hood lock control cable from the lever of the hood lock female.
3. Remove the hood lock female and guide from the hood lock bracket.
4. Remove the hood lock control from the dash side.

Note: When removing the hood lock control only, the caulked clamp must be opened because the grommet is used commonly with the speedometer cable.

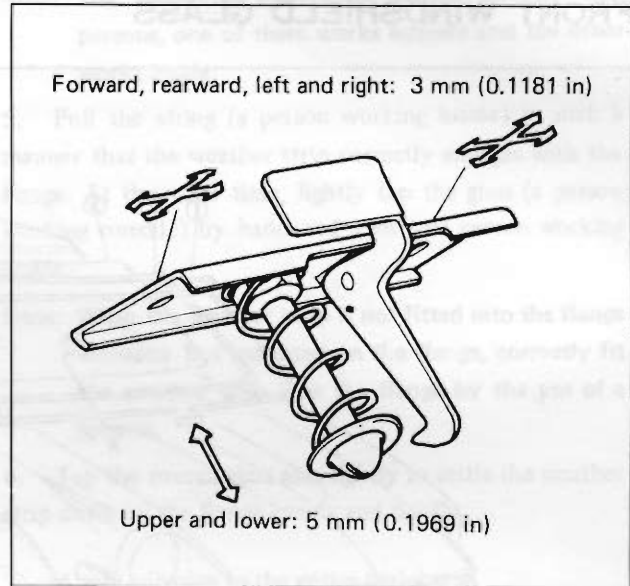

Fig. BF-12 Adjusting hood lock

Adjustment

1. When the dovetail of the hood lock male is not coincided with the guide hole, loosen and properly adjust the hood lock male installation bolt.
2. When the lock engagement is too shallow or too deep, adjust the dovetail height properly.

WINDSHIELD GLASS

CONTENTS

FRONT WINDSHIELD GLASS	BF- 8	SIDE WINDOW	BF- 9
Removal	BF- 8	TAIL GATE GLASS	BF-10
Reinstallation	BF- 8		

BODY

FRONT WINDSHIELD GLASS

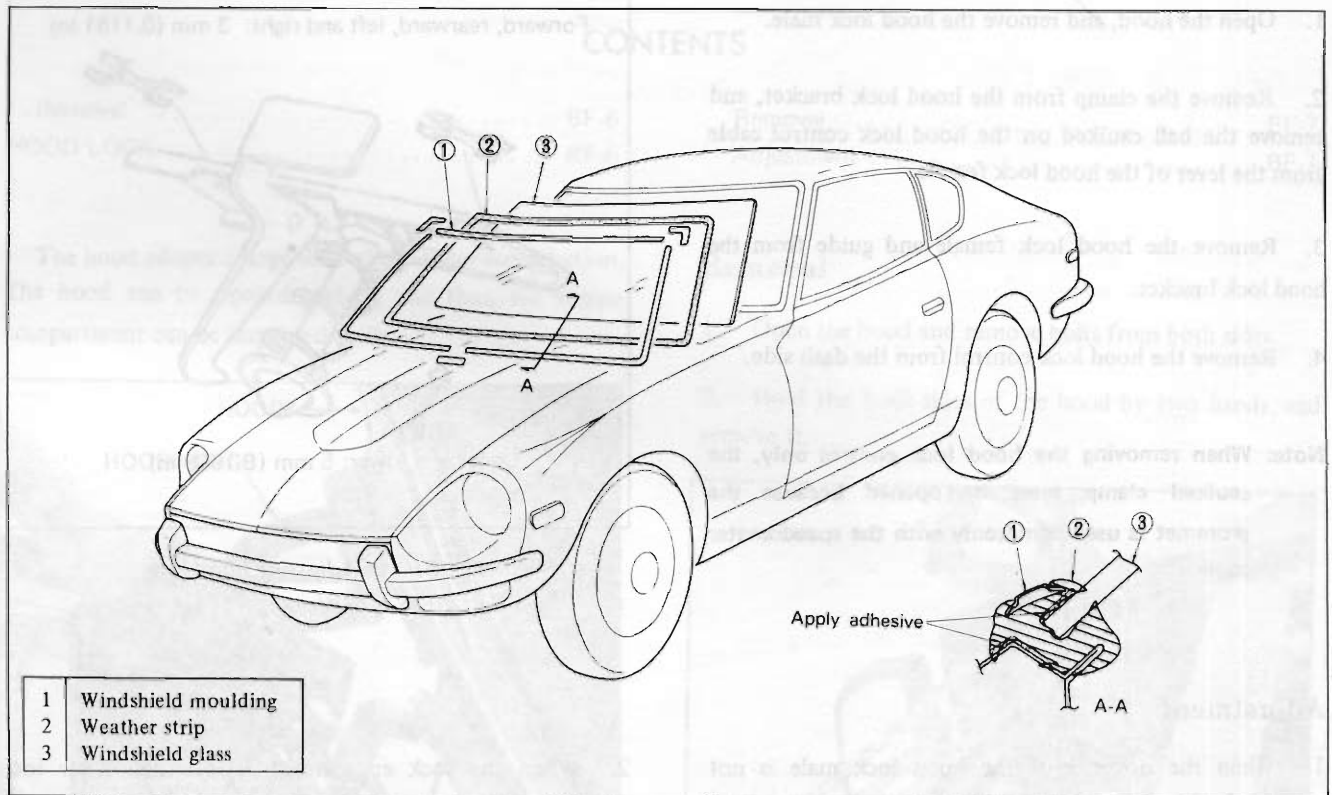

Fig. BF-13 Front windshield glass

Removal

1. Remove the rear view mirror.
2. Remove the instrument panel garnish.
3. Remove the windshield wiper blades together with the arms.
4. Remove the windshield moulding.

Note: Be careful not to deform the moulding.

5. Detach the adhesion on the windshield flange side by applying a spatula or ordinary [(-) headed] screw driver from the outside.
6. Depressing the weather strip toward outside, lightly tap and remove the windshield glass to the outside.



Fig. BF-14 Removing front windshield glass

Note: The windshield glass removing must be started from the upper side portion.

Reinstallation

1. For the installation, use string and spatula shown in Figure BF-15.

BODY

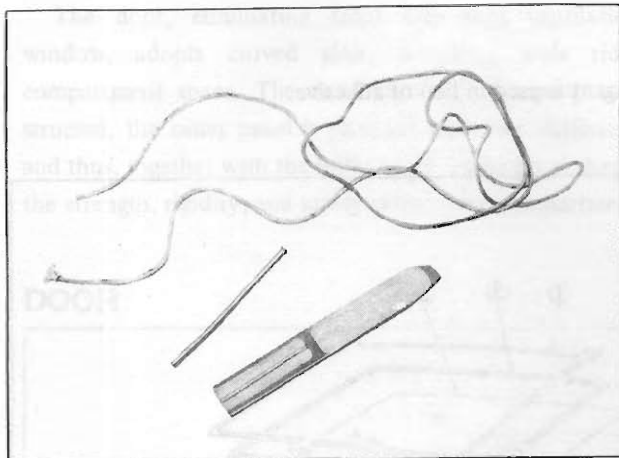

Fig. BF-15 Tools for installation of windshield glass

2. Apply adhesive to the appropriate portions on the weather strip as shown in Figure BF-13, and apply the weather strip to the windshield glass.
3. Apply string into the groove of the weather strip.
4. Set the windshield glass to the windshield flange from the outside, and put the string into the compartment side.

Note: The operation should be carried out by two persons, one of them works outside and the other works inside.

5. Pull the string (a person working inside) in such a manner that the weather strip correctly engages with the flange. At the same time, lightly tap the glass (a person working outside) by hand and assist the person working inside.

Note: When the weather strip is not fitted into the flange correctly but mounted on the flange, correctly fit the weather strip into the flange by the use of a spatula.

6. Tap the overall glass area lightly to settle the weather strip down on the flange evenly and tightly.
7. Apply adhesive to the entire periphery.
8. Install the windshield moulding.
9. Install the windshield wiper blades and arms.
10. Install the instrument panel garnish.
11. Install the rear view mirror.

SIDE WINDOW

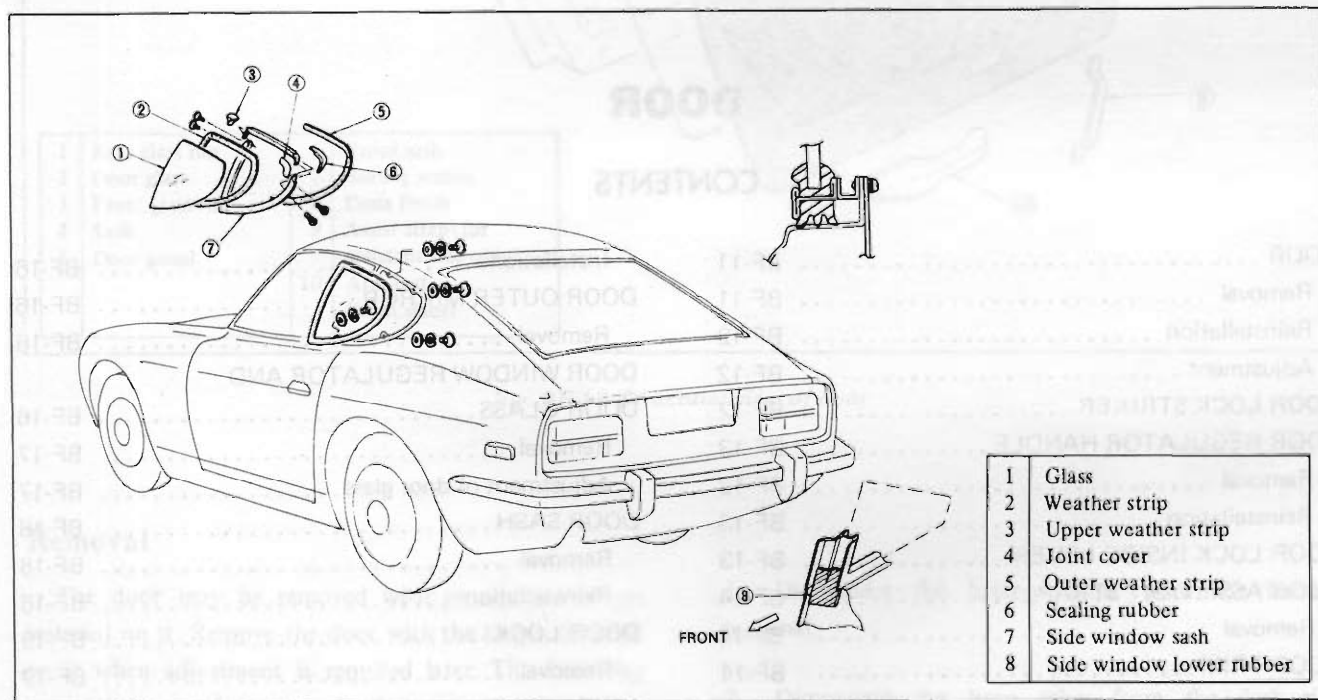

Fig. BF-16 Structural view of side window

BODY

TAIL GATE GLASS

For the tail gate glass removal and installation, the instructions for windshield glass apply. However, sealing

agent is used in lieu of adhesive.

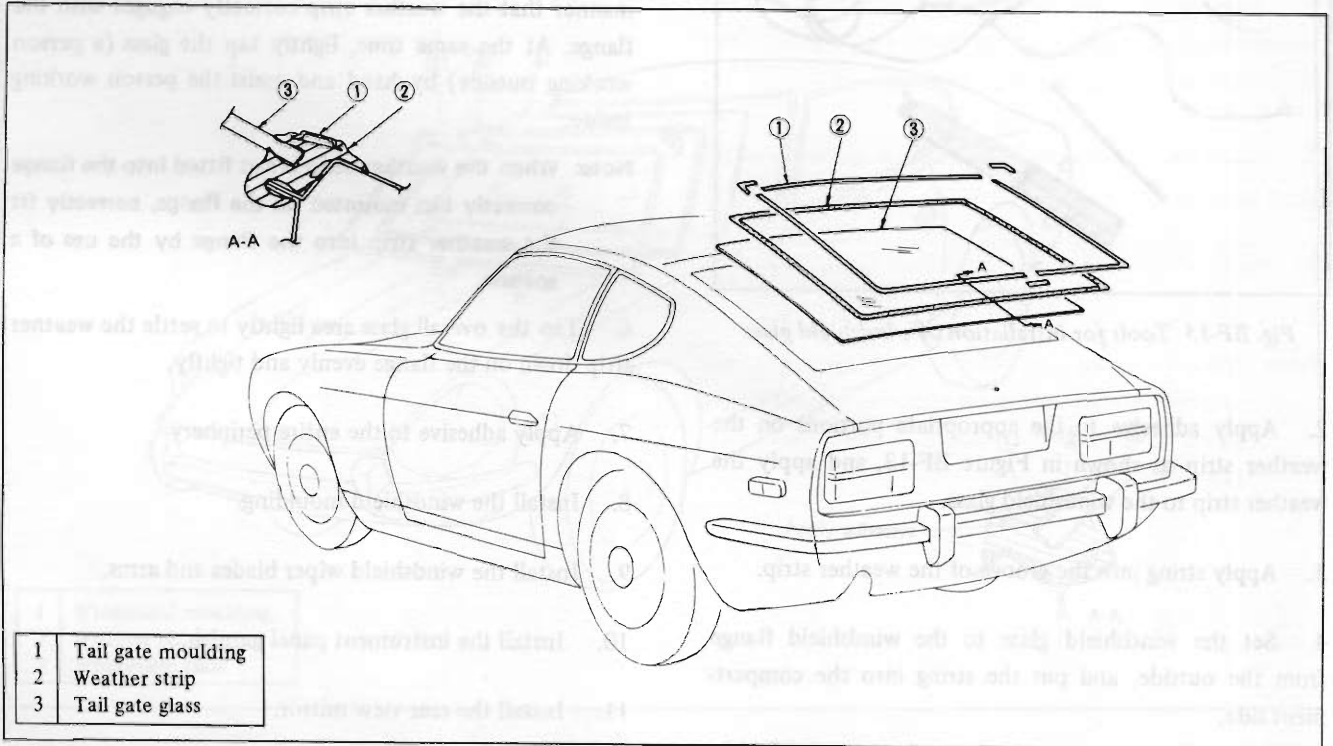

Fig. BF-17 Structural view of tail gate glass

DOOR

CONTENTS

DOOR	BF-11	Installation	BF-16
Removal	BF-11	DOOR OUTER MIRROR	BF-16
Reinstallation	BF-12	Removal	BF-16
Adjustment	BF-12	DOOR WINDOW REGULATOR AND	
DOOR LOCK STRIKER	BF-12	DOOR GLASS	BF-16
DOOR REGULATOR HANDLE	BF-13	Removal	BF-17
Removal	BF-13	Adjustment of door glass	BF-17
Reinstallation	BF-13	DOOR SASH	BF-18
DOOR LOCK INSIDE LEVER	BF-13	Removal	BF-18
DOOR ASSISTANT STRAP	BF-14	Reinstallation	BF-18
Removal	BF-14	DOOR LOCK	BF-19
DOOR TRIM	BF-14	Removal	BF-19
Removal	BF-15	Reinstallation	BF-20
DOOR SEALING SCREEN	BF-15		

BODY

The door, eliminating front side glass ventilation window, adopts curved glass, obtaining wide rider compartment space. The door main unit is rigidly constructed, the outer panel is provided with two stiffeners, and thus, together with the highly rigid inside panel shape, the strength, rigidity, and safety of the rider compartment

are highly improved.

A door lock is installed on each side of the door. The window glass regulator which supports the window glass is of an X-shape double arm type. The side handle is built in the door in such a manner that the handle is flush with the inside surface of the door.

DOOR

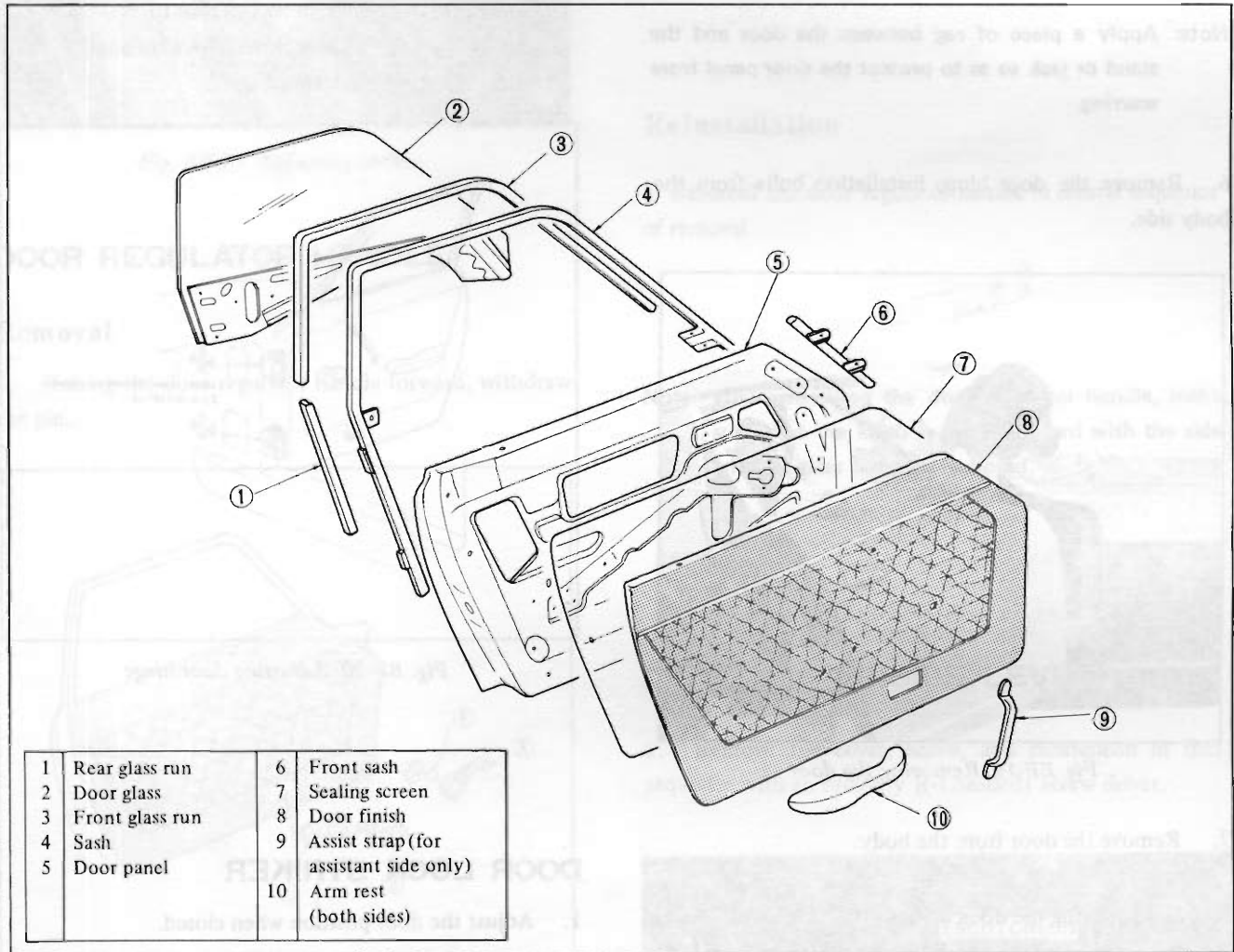

Fig. BF-18 Structural view of door

Removal

The door may be removed with or without hinges installed on it. Remove the door with the hinges installed on it when adjustment is required later. The following instructions are for removal of door with the hinges installed on it.

1. Disconnect the battery cable from the battery terminal.
2. Disconnect the horn relay from the dash side (driver's seat side only).

BODY

3. Remove the hood lock control installation bracket (driver's seat side only).
4. Remove the dash side trim.
5. With the door opened fully, support the door by applying a stand beneath the door or by means of a jack.

Note: Apply a piece of rag between the door and the stand or jack so as to protect the door panel from scarring.

6. Remove the door hinge installation bolts from the body side.



Fig. BF-19 Removing the door

7. Remove the door from the body.

When removing the door without the hinges (the hinges are remained on the body), remove the door side installation bolts from the hinges and remove the door from the hinges.

Reinstallation

Reinstall the door in reverse sequence of removal.

Door hinge installation bolt tightening torque: 2.5 to 3.0 kg-m (18.0 to 21.0 ft-lb).

Note: a. Before installing the door, be sure to apply grease to the hinge link.

b. When the door squeaks during opening and

closing, apply oil to the hinge pin top.

Adjustment

1. When adjusting the door alignment, adjust the body side installation bolts on the hinge. The door side installation bolts on the hinges are not adjustable.

Adjusting stroke: 3 mm (0.1181 in) to upper, lower, forward and rearward

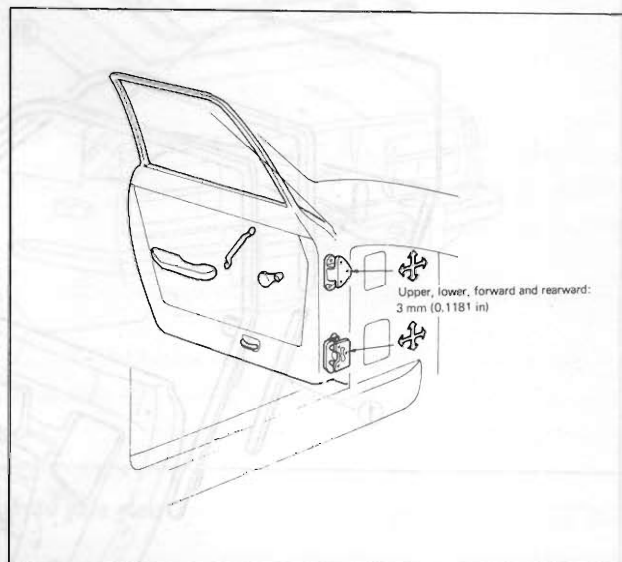

Fig. BF-20 Adjusting door hinge

DOOR LOCK STRIKER

1. Adjust the door position when closed.
2. Adjust the door lock striker correctly so that the door can be closed lightly and securely.
3. Adjust the door lock striker position with three striker installation screws. A dovetail used to protect the door from lowering is tightened together with the striker. Adjust the dovetail also when adjusting the door lock striker.

Adjusting stroke: 3 mm (0.1181 in) to upper, lower, right and left directions

BODY

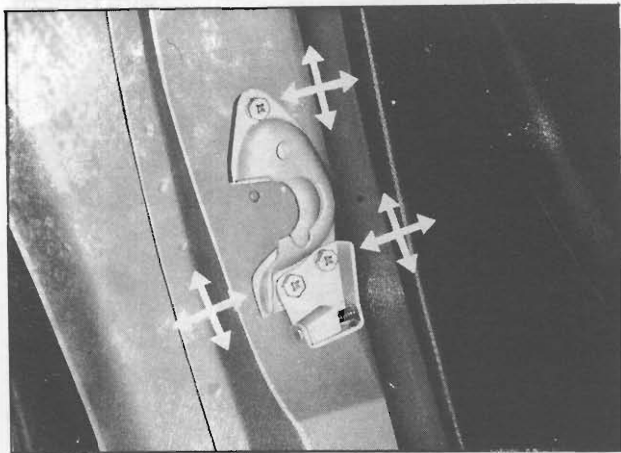

Fig. BF-21 Adjusting striker

DOOR REGULATOR HANDLE

Removal

1. Raising the door regulator handle forward, withdraw the pin.

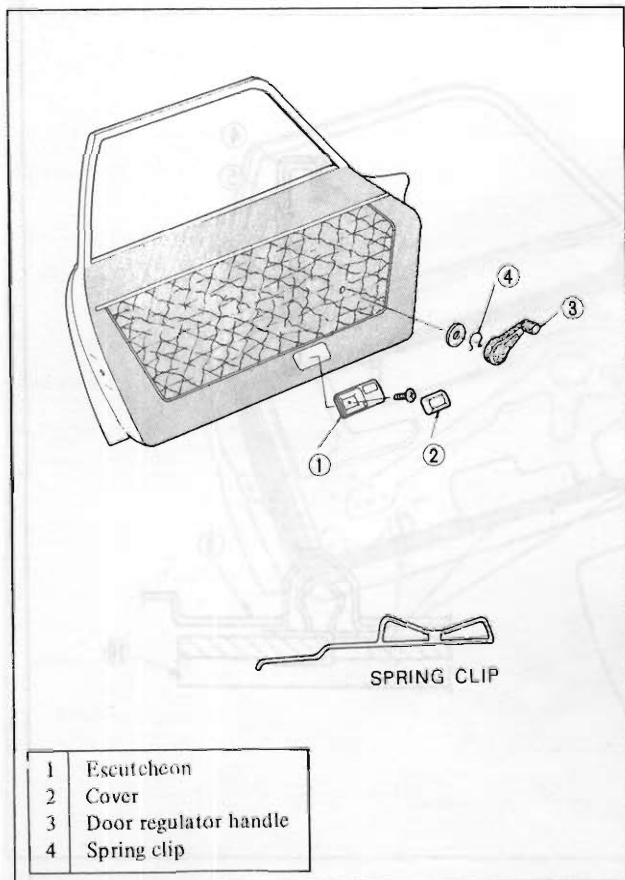

Fig. BF-22 Removing door regulator handle

Note: The tool shown in the Figure BF-22 should be made and used for this operation.

2. Remove the door handle from the door.

Reinstallation

Reinstall the door regulator handle in reverse sequence of removal.

Note: When installing the door regulator handle, make sure that the knob is faced forward with the side window glass completely closed.

DOOR LOCK INSIDE LEVER

1. Remove the cover, screw, and escutcheon in that sequence with an ordinary [(-) headed] screw driver.

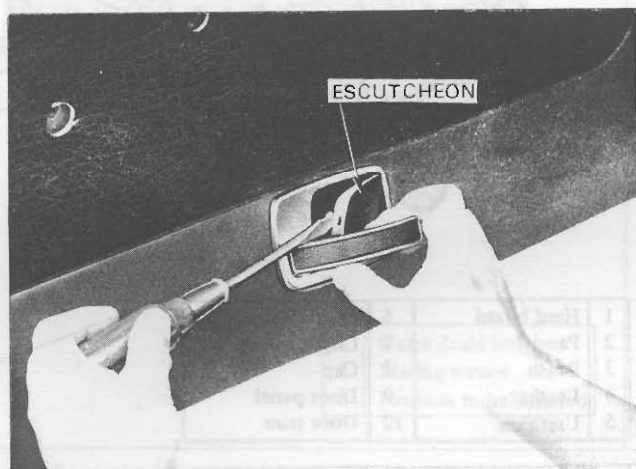

Fig. BF-23 Removing cover

BODY

DOOR ASSISTANT STRAP

Removal

1. Raise the cover with an ordinary [(-) headed] screw driver.
2. Remove the installation screws with a cross-headed screw driver.
3. Remove the assistant strap.

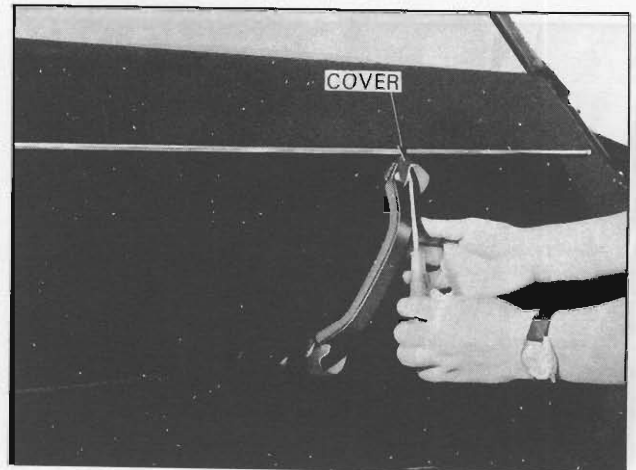
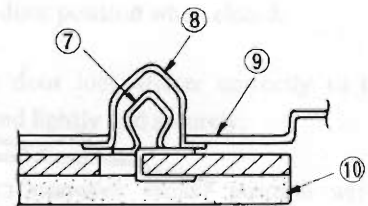
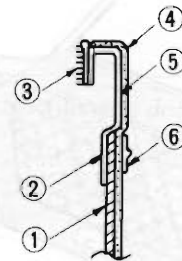
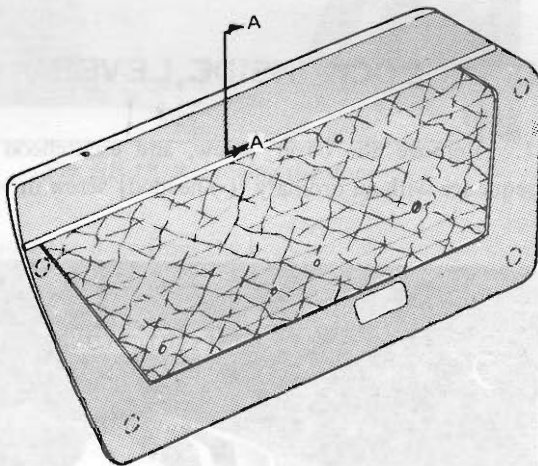

Fig. BF-24 Removing assistant strap cover

DOOR TRIM



1	Hard board	6	Moulding
2	Panel	7	Clip
3	Brush	8	Cap
4	Leather	9	Door panel
5	Urethane	10	Door trim

Fig. BF-25 Removing door trim

BODY

Removal

1. Remove the inside handle, escutcheon, and regulator handle from the door.
2. Remove the arm rest, assistant strap, and door lock knob from the door.
3. Insert an ordinary [(-) headed] screw driver between the door finish and door inner panel, and unhook the door finish clips from the door panel.
4. Raising the door finish, remove it.



Fig. BF-26 Removing door finish

DOOR SEALING SCREEN

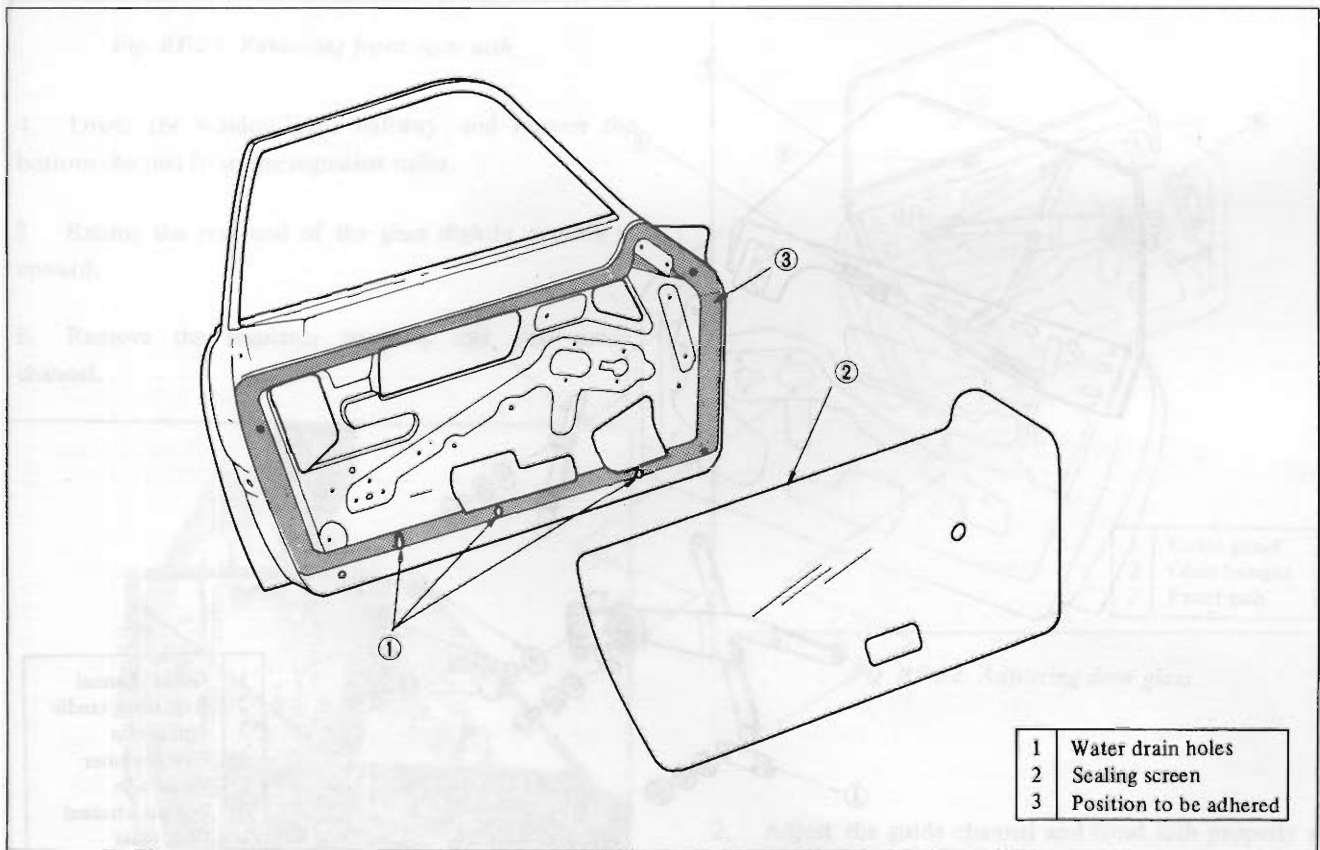

Fig. BF-27 Installing door sealing screen

BODY

Installation

1. Apply adhesive to the panel, and stick the sealing screen on the panel.
2. Be careful not to choke the water drain hole on the inner panel.
3. Stick the sealing screen carefully and correctly so that the adhered surface is not wrinkled.

DOOR OUTER MIRROR

Removal

1. Remove the door components up to extent of the

door finish and sealing screen.

2. Remove the door glass assembly. (For the details, refer to page BF-17.)
3. Loosen the nuts by applying tool from the opening on the door inner panel.
4. Remove the outer mirror.

DOOR TRIM

DOOR WINDOW REGULATOR AND DOOR GLASS

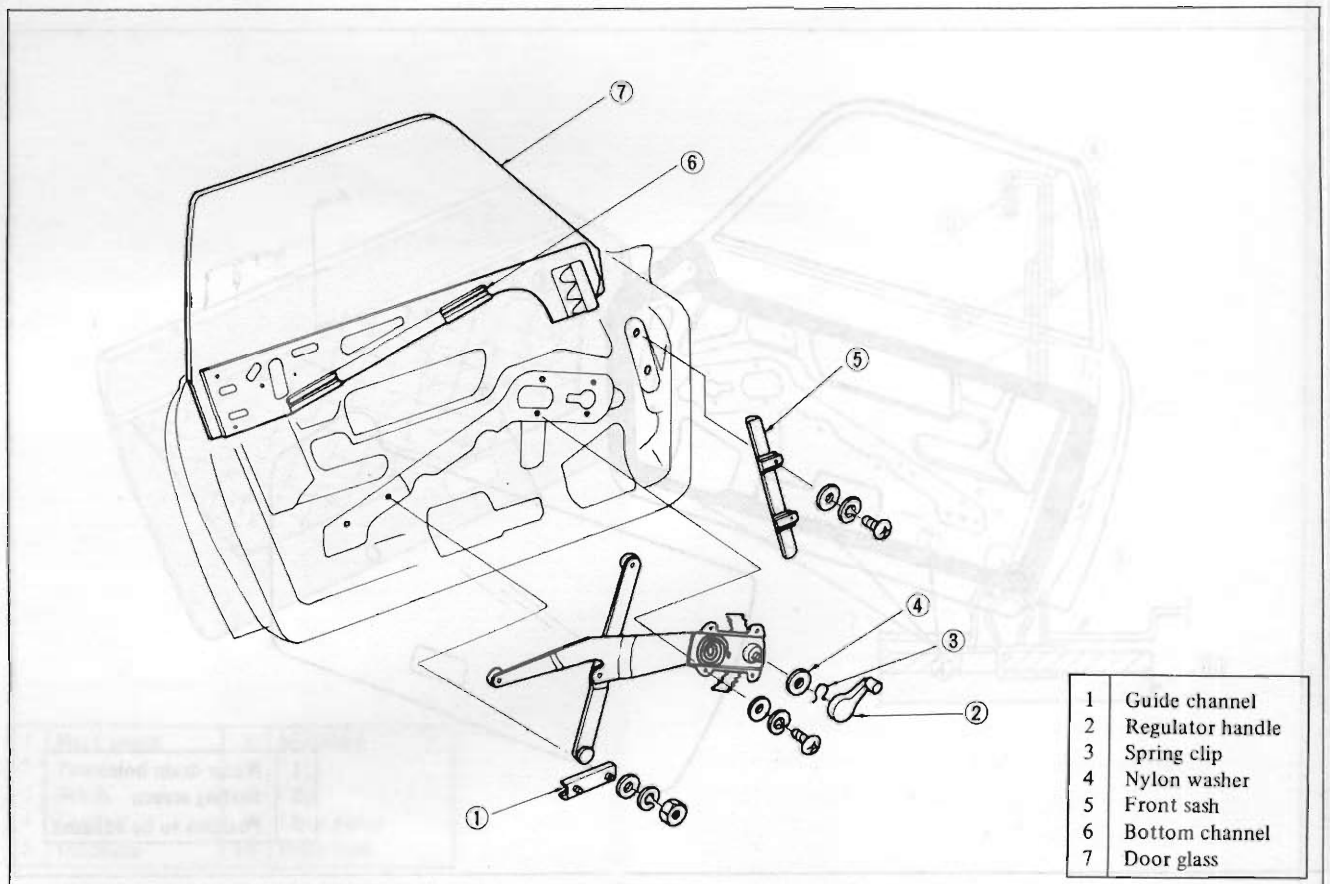

Fig. BF-28 Door window regulator and door glass

BODY

Removal

1. Remove the door components up to extent of the door sealing screen.
2. Remove the door outside moulding and glass bumper with an ordinary. [(-) headed] screw driver.
3. Raise the glass to the top, slide the front window sash downward, and remove it.

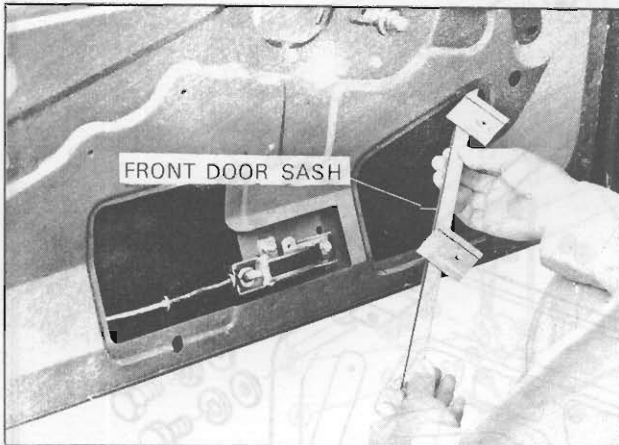

Fig. BF-29 Removing front door sash

4. Lower the window glass halfway, and remove the bottom channel from the regulator roller.
5. Raising the rear end of the glass slightly, remove it upward.
6. Remove the regulator assembly and glass guide channel.



Fig. BF-30 Removing door glass

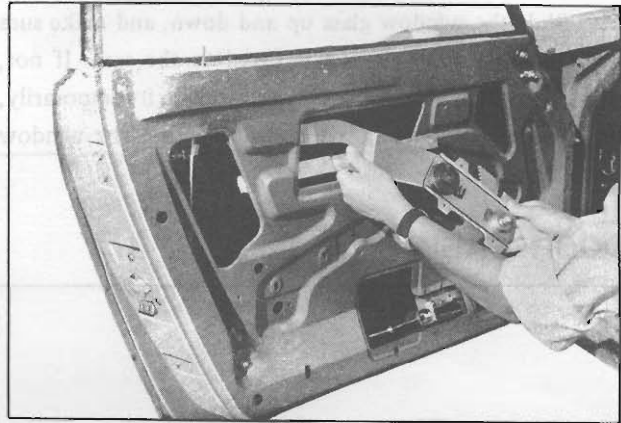

Fig. BF-31 Removing door window regulator

Adjustment of door glass

1. Install the door outside moulding and glass bumper before adjusting the glass alignment.

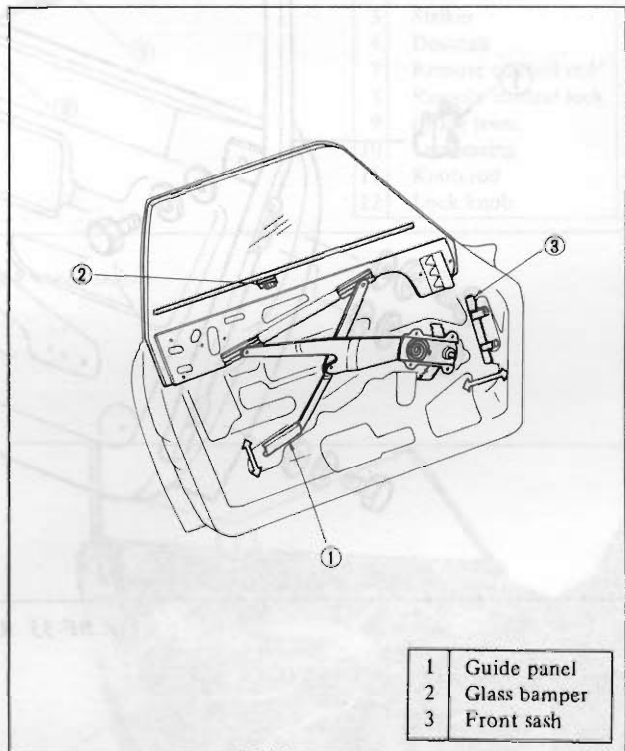

Fig. BF-32 Adjusting door glass

2. Adjust the guide channel and front sash properly so that the window glass rises and lowers smoothly along the front sash.

BODY

3. Slide the window glass up and down, and make sure that the rear edge of glass is fitted to the sash. If not, move the guide channel downward, secure it temporarily, and tighten completely after ensuring that the window

glass correctly engages with the sash. Adjust the front sash at the same time.

4. Install the front sash.

DOOR SASH

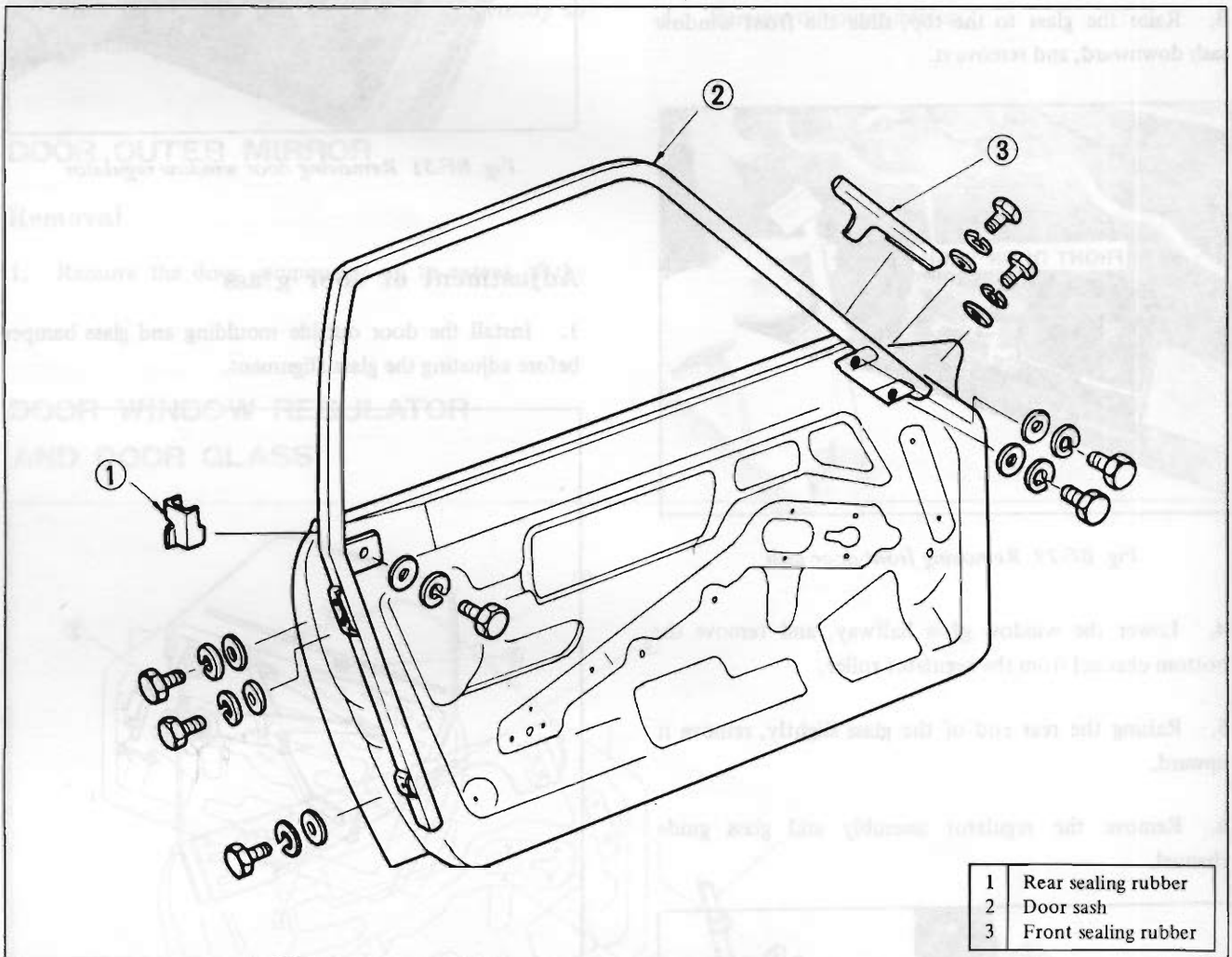

Fig. BF-33 Removing door sash

Removal

1. Remove the door components up to extent of the door glass.
2. Remove both the front and rear sealing rubbers.
3. Remove the door sash.

Reinstallation

Install the door sash in reverse sequence of removal.

Note: The door sash can be adjusted slightly. Adjust as required.

BODY

DOOR LOCK

Removal

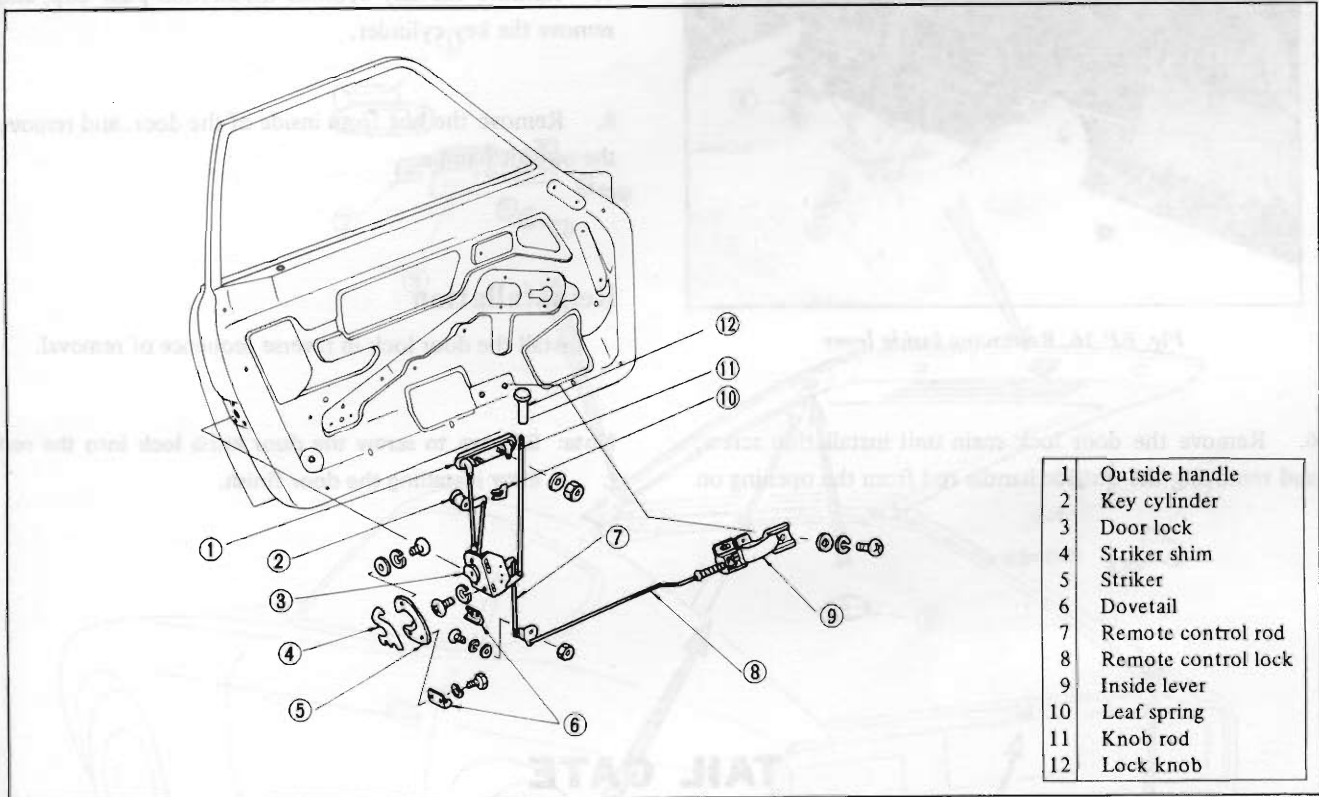
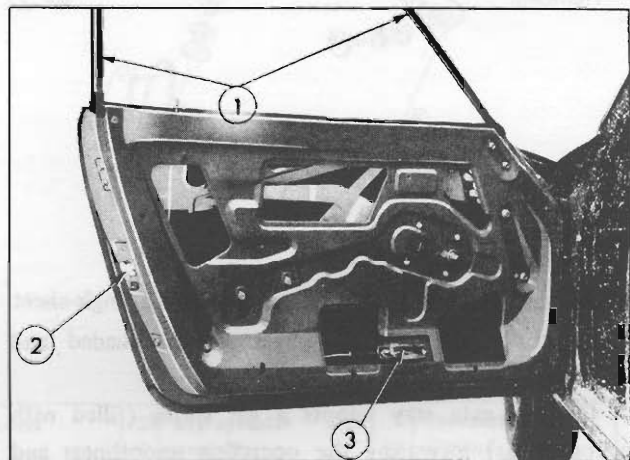

Fig. BF-34 Door lock mechanism

1. Remove the door components up to extent of the sealing screen.
2. Remove the door sash.
3. Remove the key cylinder rod from the key cylinder.
4. Remove the remote control rod from the lock main unit.
5. Remove the remote control side bell crank and inside lever installation screws, and remove the remote control mechanism from the opening on the inner panel.



1	Door sash	3	Inside lever
2	Door lock assembly		

Fig. BF-35 Door without sealing screen

BODY

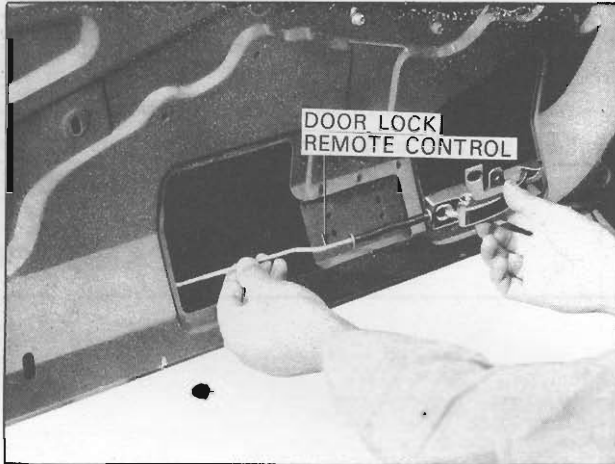

Fig. BF-36 Removing inside lever

6. Remove the door lock main unit installation screw, and removing the outside handle rod from the opening on

the door lock main unit, remove the lock main unit from the opening on the inside panel.

7. Remove the key cylinder installation plate clip, and remove the key cylinder.

8. Remove the nut from inside of the door, and remove the outside handle.

Reinstallation

Install the door lock in reverse sequence of removal.

Note: Be sure to screw the door knob lock into the rod after installing the door finish.

TAIL GATE

CONTENTS

Description	BF-20	Removing tail gate lock	BF-22
Removal	BF-22	Adjustment	BF-22

Description

The tail gate which opens upward adopts a single-sheet construction, and thus, luggages can be loaded and unloaded conveniently.

The tail gate stay adopts a gas spring (filled with nitrogen gas) increasing the operating smoothness and improving the external appearance.

Note: The gas spring is filled with highly compressed nitrogen gas. Do not disassemble the tail gate stay.

In order to ease the tail gate installation and removal, split type hinges are used. The hinges are secured with both side installation screws.

A push-button type tail gate lock has been adopted. When the push-button is locked, the push-button can be depressed but not unlocked.

BODY

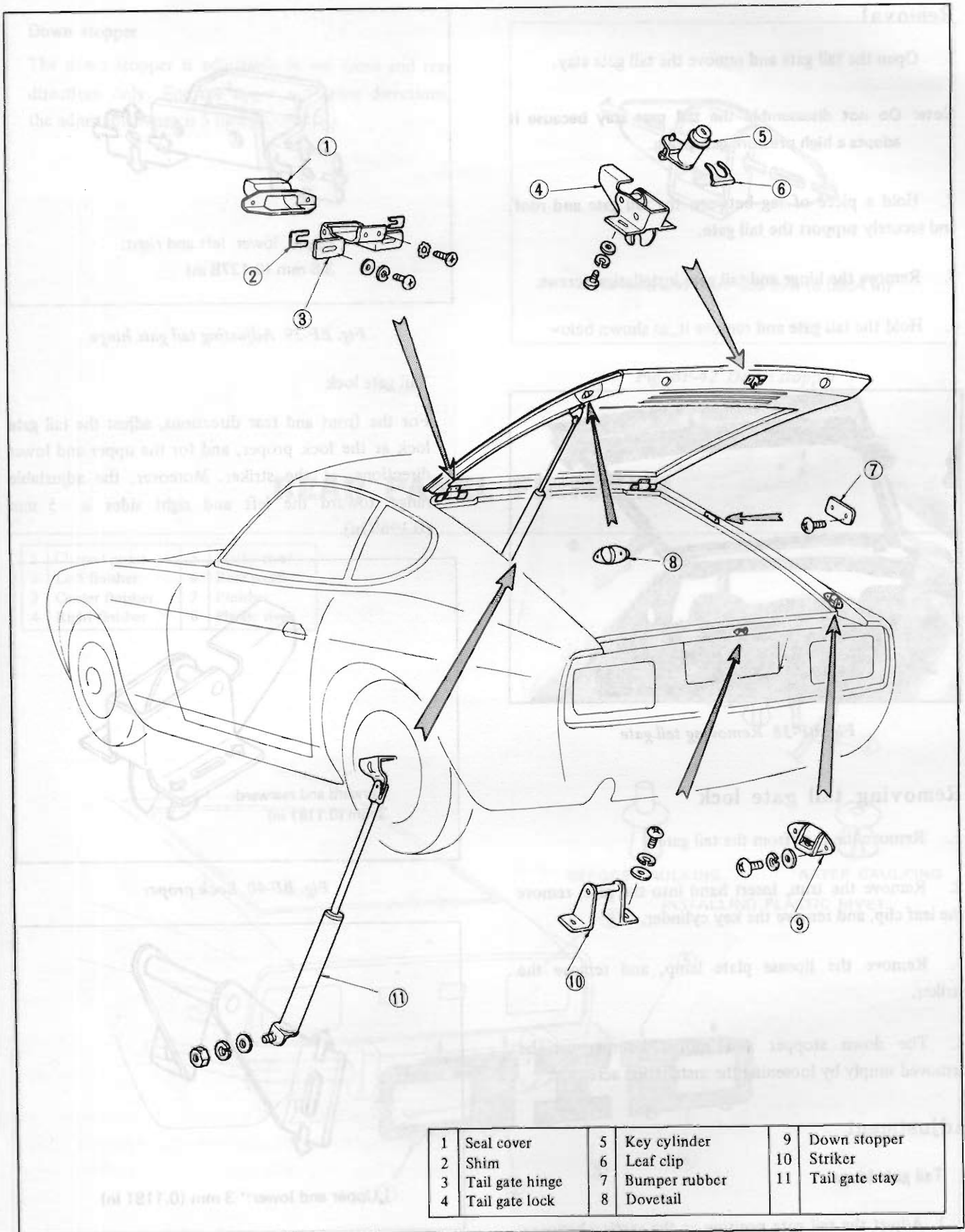

Fig. BF-37 Structural view of tail gate

Removal

1. Open the tail gate and remove the tail gate stay.

Note: Do not disassemble the tail gate stay because it adopts a high pressure gas spring.

2. Hold a piece of rag between the tail gate and roof, and securely support the tail gate.
3. Remove the hinge and tail gate installation screws.
4. Hold the tail gate and remove it, as shown below.



Fig. BF-38 Removing tail gate

Removing tail gate lock

1. Remove the lock from the tail gate.
2. Remove the trim, insert hand into the gate, remove the leaf clip, and remove the key cylinder.
3. Remove the license plate lamp, and remove the striker.
4. The down stopper and rubber bumper can be removed simply by loosening the installation screws.

Adjustment

Tail gate hinge

1. Adjust the tail gate position at the section between the hinge and and body.

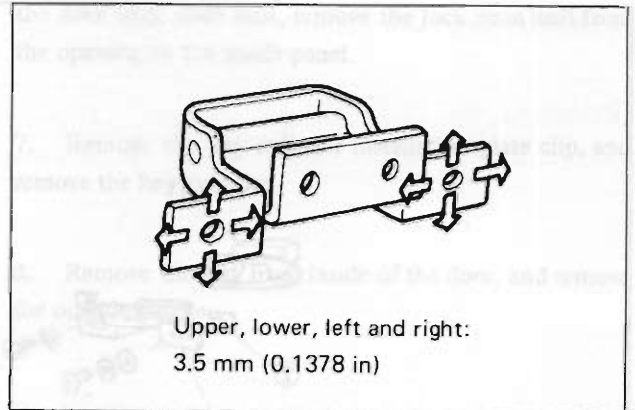

Fig. BF-39 Adjusting tail gate hinge

Tail gate lock

For the front and rear directions, adjust the tail gate lock at the lock proper, and for the upper and lower directions, at the striker. Moreover, the adjustable range toward the left and right sides is 5 mm (0.1969 in).

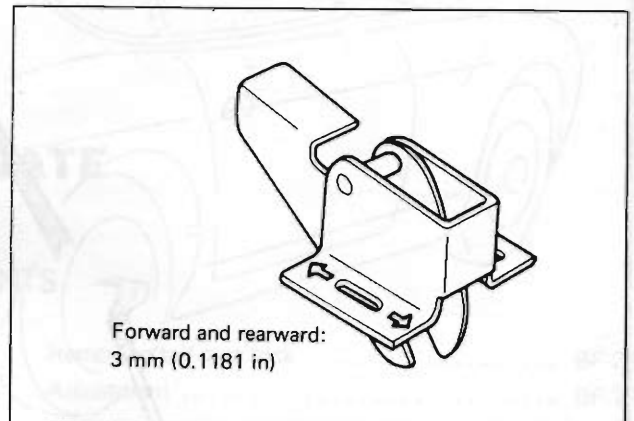

Fig. BF-40 Lock proper

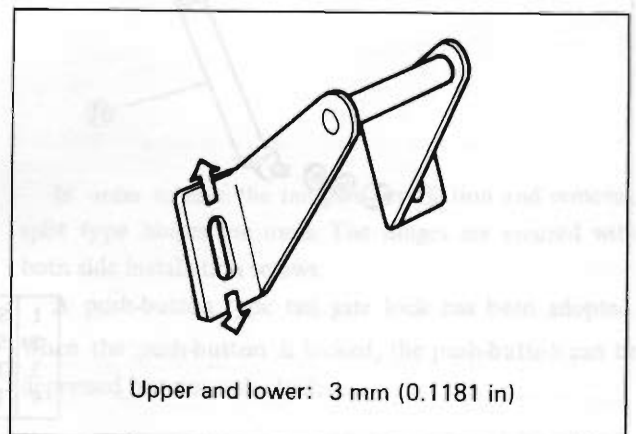

Fig. BF-41 Striker

BODY

Down stopper

The down stopper is adjustable in the front and rear directions only. For the upper and lower directions, the adjustable range is 5 mm (0.1969 in).

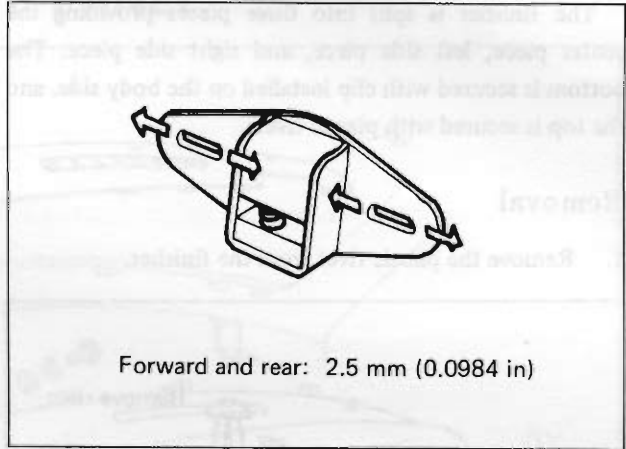

Fig. BF-42 Down stopper

REAR PANEL FINISHER

1	Clipped point	5	Plastic rivet
2	Left finisher	6	Rear panel
3	Center finisher	7	Finisher
4	Right finisher	8	Plastic rivet

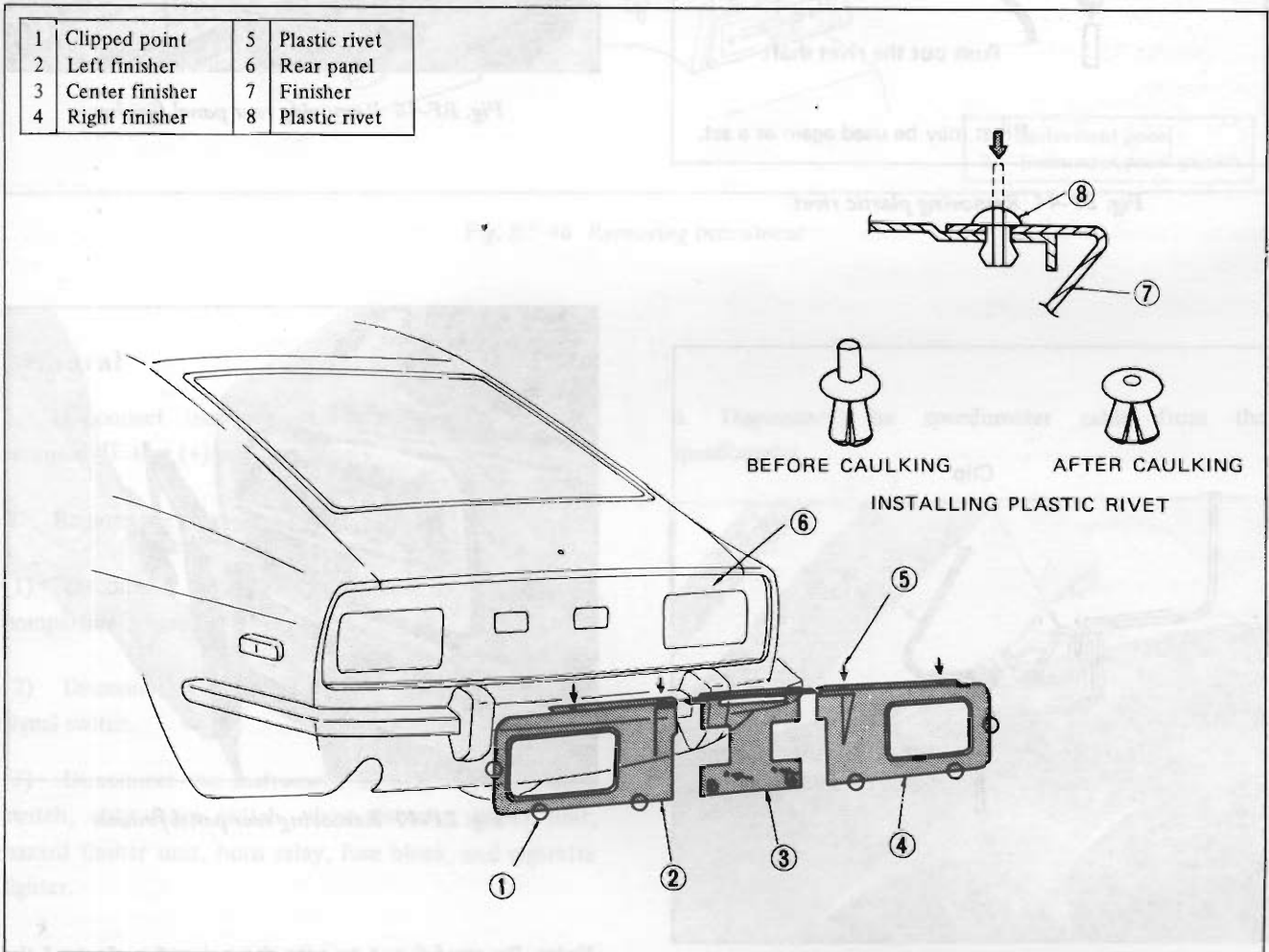

Fig. BF-43 Rear panel finisher

BODY

The finisher is split into three pieces providing the center piece, left side piece, and right side piece. The bottom is secured with clip installed on the body side, and the top is secured with plastic rivets.

Removal

1. Remove the plastic rivet from the finisher.

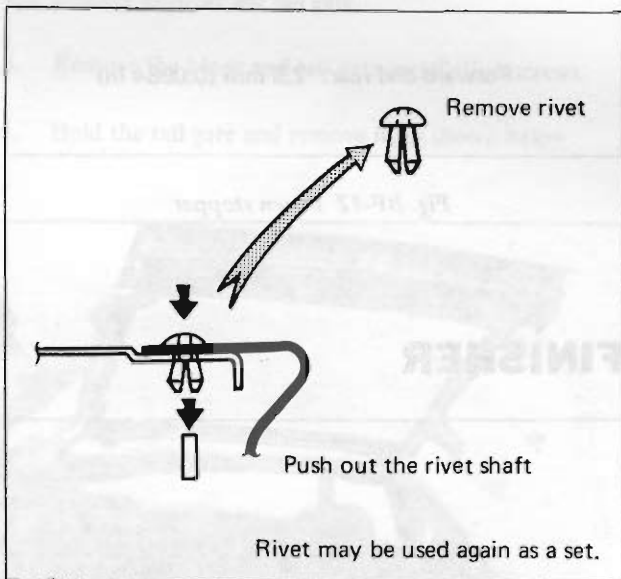

Fig. BF-44 Removing plastic rivet

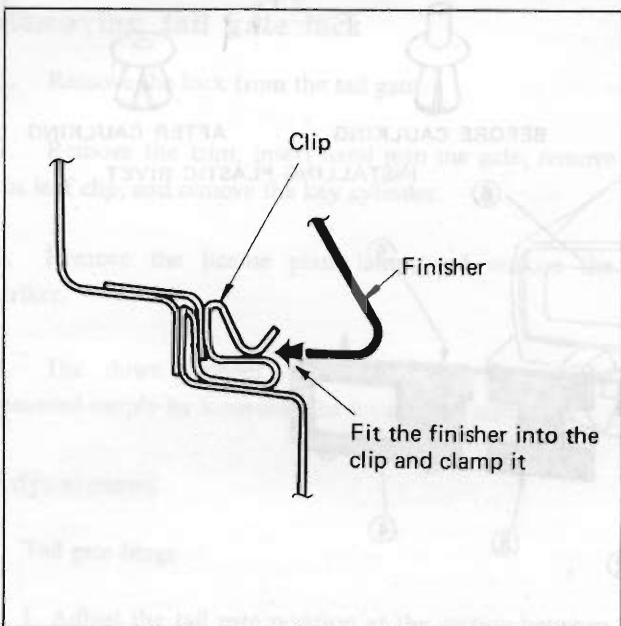

Fig. BF-45 Fitting finisher clip

2. Remove the license plate lamp.
3. Pulling the finisher, remove it from the clip unit.
4. Tilt and withdraw the finisher, and remove it from the license plate unit.

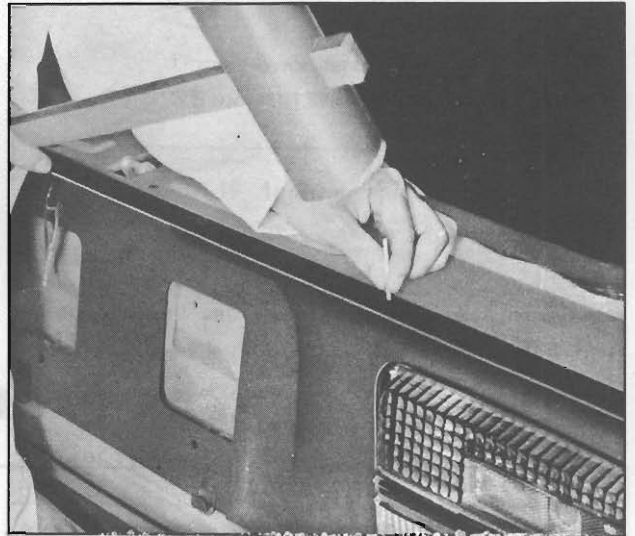

Fig. BF-46 Removing rear panel finisher



Fig. BF-47 Removing rear panel finisher

Note: Be careful not to scar the painted surface of the body with the finisher flange.

BODY

INSTRUMENT PANEL

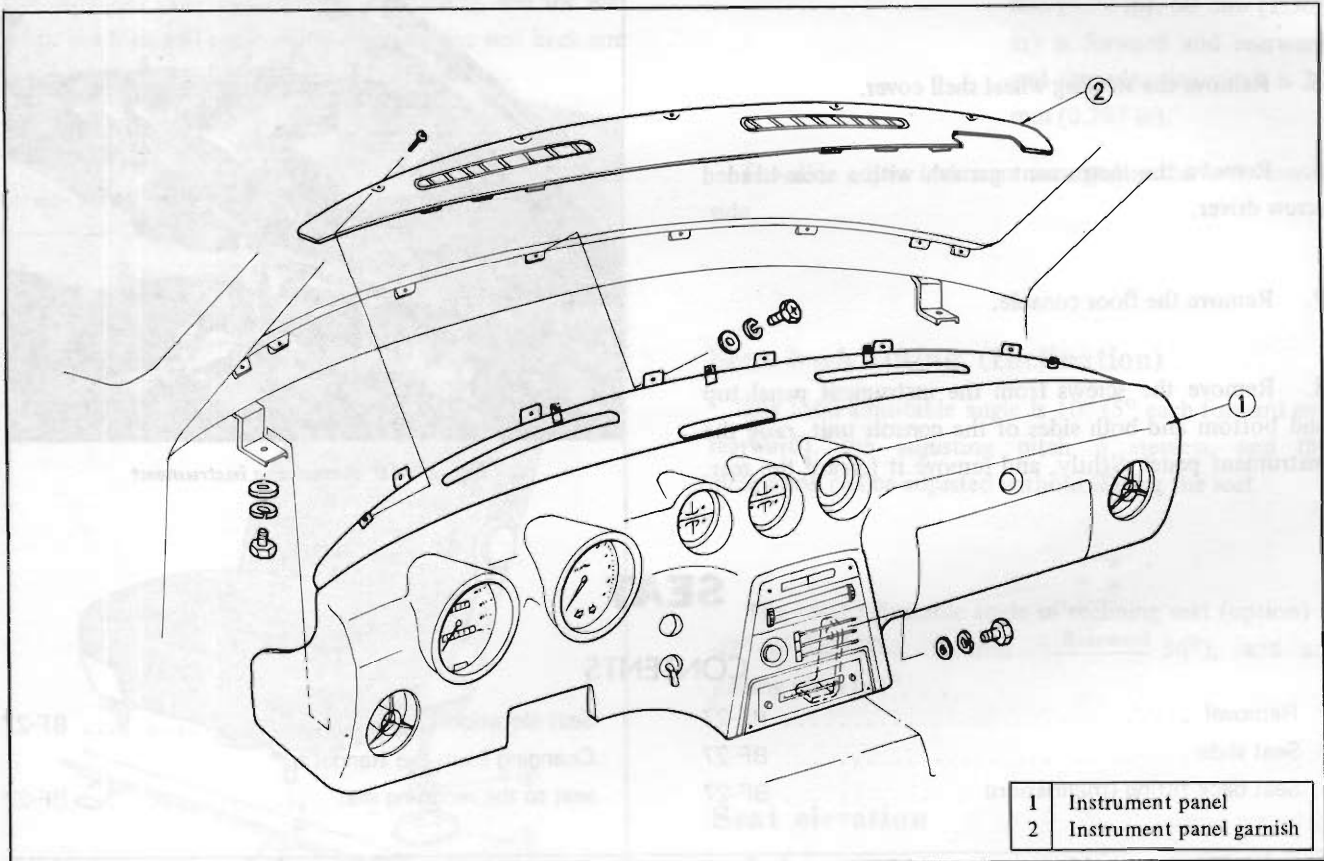

Fig. BF-48 Removing instrument

Removal

1. Disconnect the battery cable from the battery terminal. [Either (+) or (-) terminal]

2. Remove the wiring harness.

(1) Disconnect the instrument harness from the engine compartment harness.

(2) Disconnect the instrument harness from the turn signal switch.

(3) Disconnect the instrument harness from the door switch, stop lamp switch, alarm buzzer, flasher unit, hazard flasher unit, horn relay, fuse block, and cigarette lighter.

3. Disconnect the speedometer cable from the speedometer.

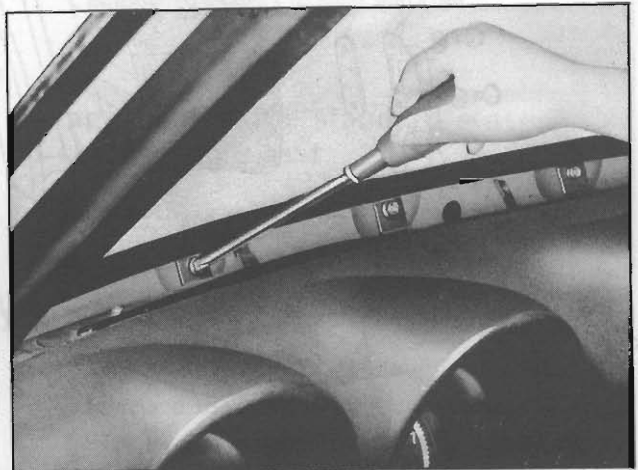

Fig. BF-49 Removing instrument

BODY

4. Disconnect the heater control cable at the heater side.
5. Remove the steering wheel shell cover.
6. Remove the instrument garnish with a cross-headed screw driver.
7. Remove the floor console.
8. Remove the screws from the instrument panel top and bottom and both sides of the console unit, raise the instrument panel slightly, and remove it toward the rear.

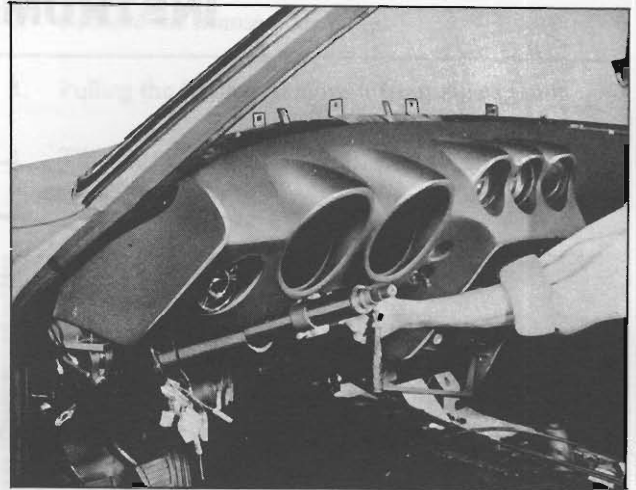

Fig. BF-50 Removing instrument

SEAT

CONTENTS

Removal	BF-27	Seat elevation	BF-27
Seat slide	BF-27	Changing from the standard	
Seat back tilting (Inclination)	BF-27	seat to the reclining seat	BF-27

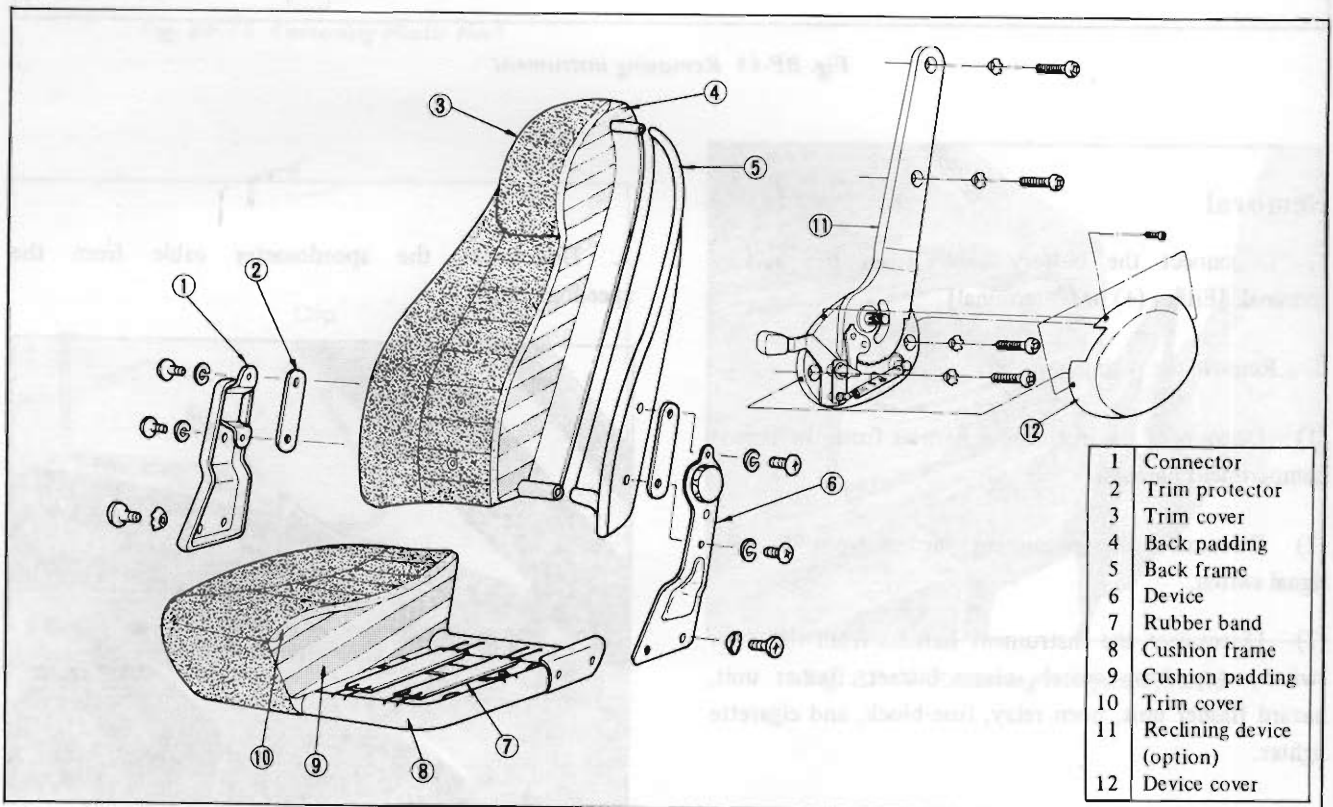

Fig. BF-51 Structural view of seat

BODY

The bucket type separate seats completely hold driver and assistant even during a rapid cornering, and the seat back is a high seat back which combines the seat back and head rest.

The reclining seat back is furnished as an option. Reclining the seat can be made by attaching reclining device instead of the device for standard seat.

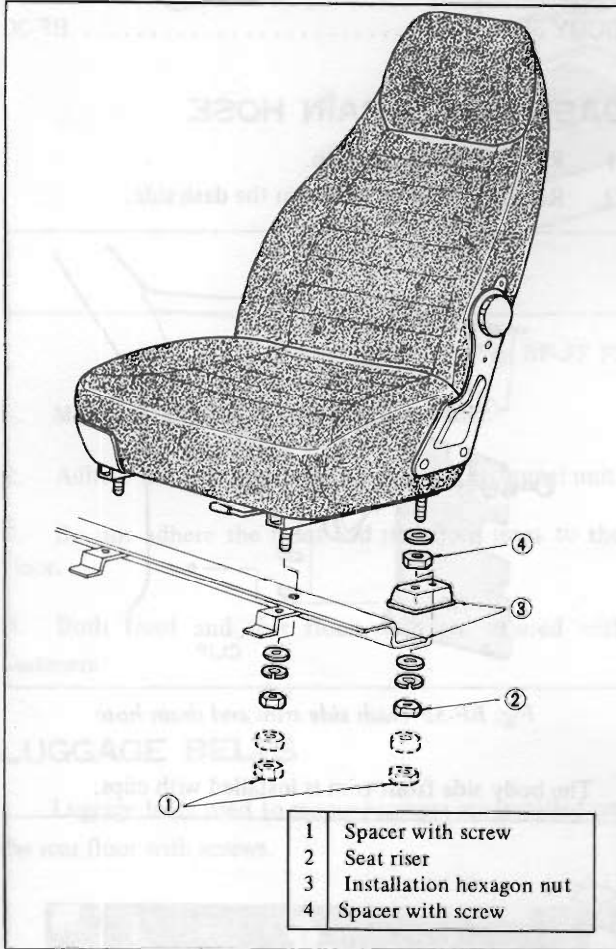

Fig. BF-52 Removing and reinstalling seat

Removal

1. Loosen the seat installation nuts by inserting hand beneath the seat riser, and remove the seat.

Seat slide

Driver's Seat The total slide stroke is 180 mm (7.09 in), 100 mm (3.93 in) is forward and 80 mm (3.15 in) is rearward, and the adjusting pitch is 20 mm (0.787 in).

Assistant Driver's Seat.....The total slide stroke is 120 mm (4.72 in), 60 mm (2.362 in) is forward and rearward and the adjusting pitch is 20 mm (0.787 in).

The slide adjust levers are arranged in the body center side.

Seat back tilting (Inclination)

The total adjustable angle is 10° (5° each forward and rearward), the adjusting pitch is stepless, and the inclination can be adjusted without leaving the seat.

The total adjustable angle of reclining seat (option) is 42° (6° Forward Neutral Rearward 36°), and adjusting pitch is 3°.

Seat elevation

Both seats can be adjusted 20 mm (0.787 in) each upward and downward. The seat elevation is adjusted with the spacer indicated in dotted line in Figure BF-53. When it is desired to raise the seat, place the spacer on the seat riser. Contrarily, when desired to lower the seat, remove the spacer.

Note: When spacers are used, be sure to apply the same number of spacers to each seat riser.

Changing from the standard seat to the reclining seat

1. Remove the device for the standard seat.
2. Install the reclining device with its cover off, and then attach the cover to the device.

Note: Two reclining devices are used: one equipped with lever and the other with return spring. The device with lever is installed on the door side of the seat and the other is installed on the inner side of the seat.

BODY

INTERIOR TRIMS

CONTENTS

DASH SIDE TRIM	BF-28	FRONT FLOOR MAT AND INSULATOR	BF-29
Removal	BF-28	LUGGAGE BELTS	BF-29
DASH INSULATOR	BF-28	REAR FLOOR TRIMS	BF-29
DASH SIDE DRAIN HOSE	BF-28	INSIDE REAR VIEW MIRROR	BF-29
BODY SIDE TRIM	BF-28	BODY SEALING	BF-30

DASH SIDE TRIM

Removal

1. Remove the flasher unit installation screws.
2. Remove the horn relay installation screws.
3. Raise the trim dash side holding clip.
4. Remove the rubber grommet.
5. Remove the dash side trim.

DASH INSULATOR

The dash insulator has been adhered and connected with clips toward the entire area so that sound is insulated effectively. For this reason, the insulator can be removed only by peeling it off. When the insulator is removed once, replace it with a new one.

BODY SIDE TRIM

Except for the body side front trim, all trims are installed with plastic rivets.

DASH SIDE DRAIN HOSE

1. Remove the hose clamp.
2. Remove the grommet from the dash side.

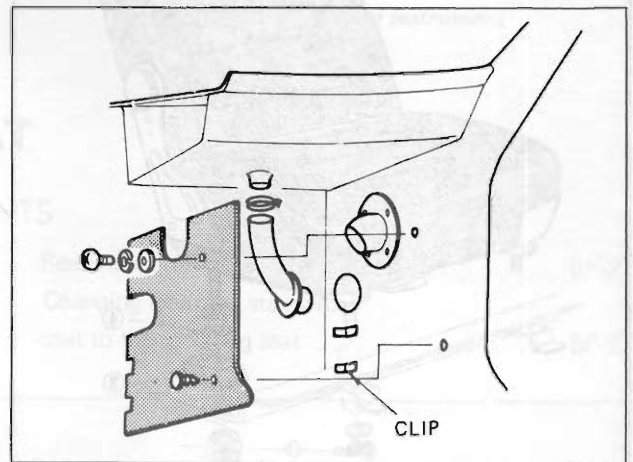

Fig. BF-53 Dash side trim and drain hose

The body side front trim is installed with clips.

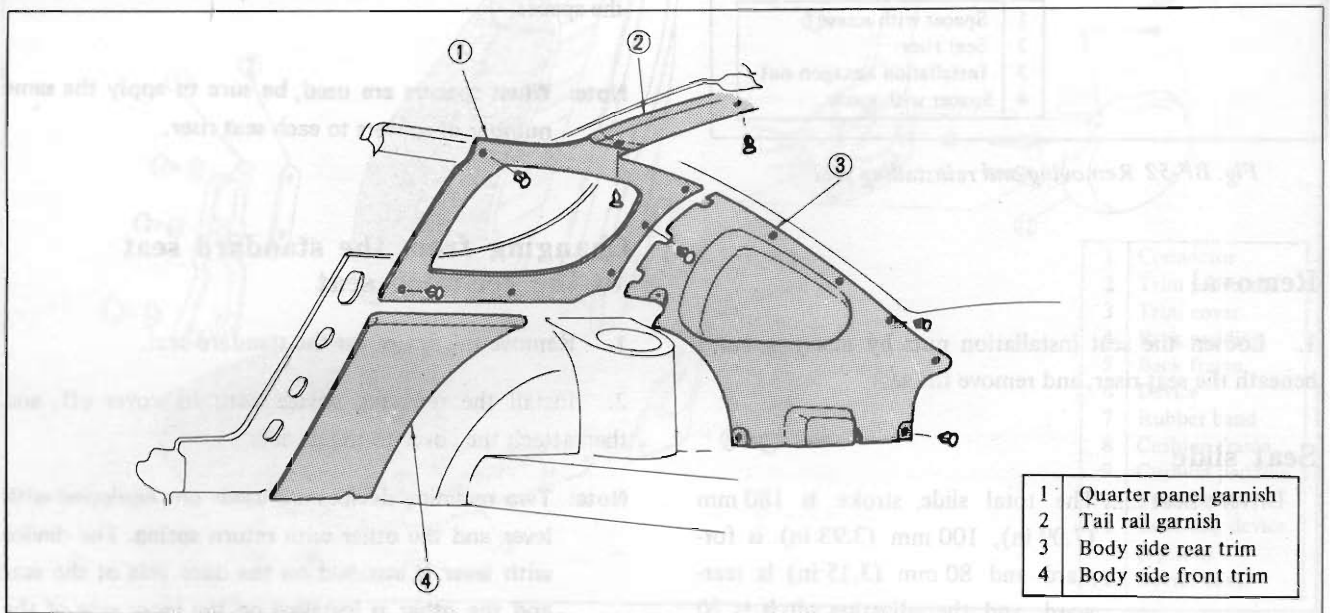

Fig. BF-54 body side trim

BODY

FRONT FLOOR MAT AND INSULATOR

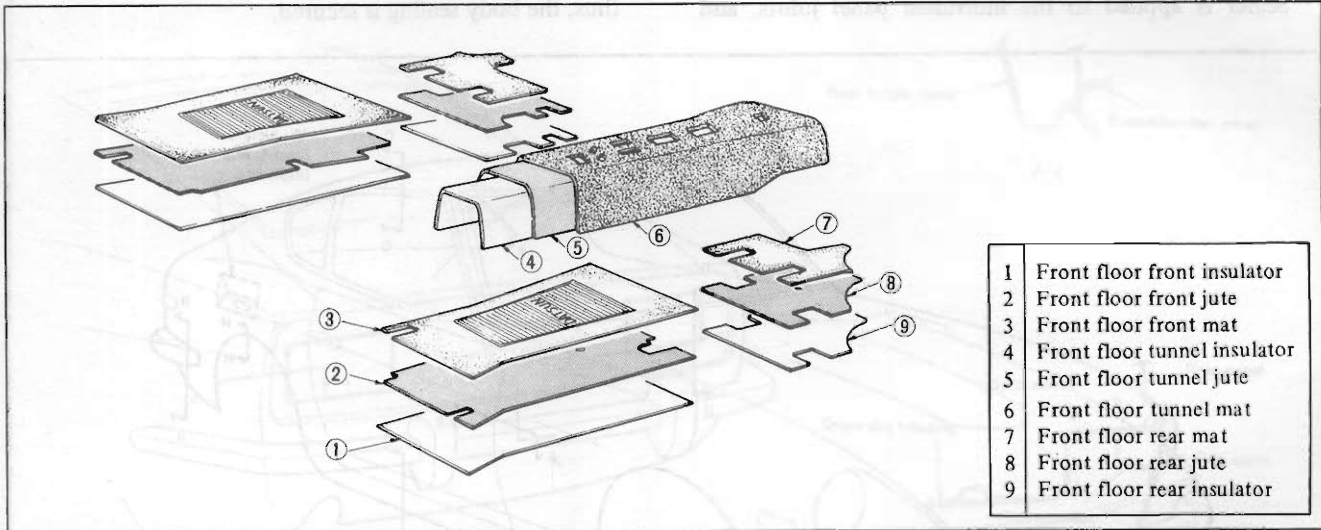

Fig. BF-55 Floor mat and insulator

1. Melt and put insulator on the floor panel.
2. Adhere the front floor tunnel jute to the tunnel unit.
3. Do not adhere the front and rear floor jutes to the floor.
4. Both front and rear floor mats are secured with fasteners.

REAR FLOOR TRIMS

1. Install the luggage stopper with self-tapping screws.
2. Install the rear floor mat on the floor with fasteners.
3. Install the seat riser trim with adhesive.
4. Install the rear suspension strut cap by means of fitting.
5. Install the luggage belts with machine screws.

LUGGAGE BELTS

1. Luggage belts used to secure luggages are installed on the rear floor with screws.

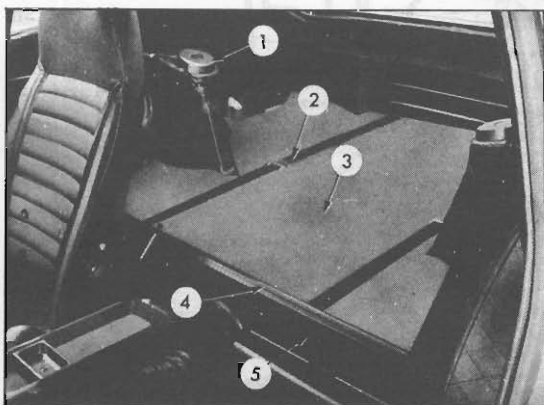

1	Rear suspension strut cap	3	Rear floor mat
2	Luggage belt	4	Luggage stopper
		5	Seat riser trim

Fig. BF-56 Rear floor trim and luggage belt

INSIDE REAR VIEW MIRROR

Install the rear view mirror on the body through a drop-off system mechanism.

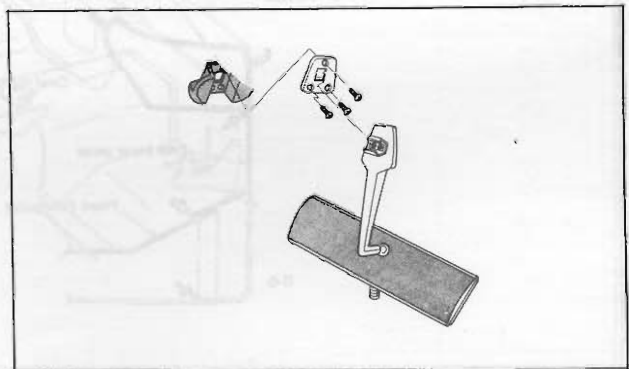

Fig. BF-57 Removing inside rear view mirror

BODY

BODY SEALING

Sealer is applied to the individual panel joints, and thus, the body sealing is secured.

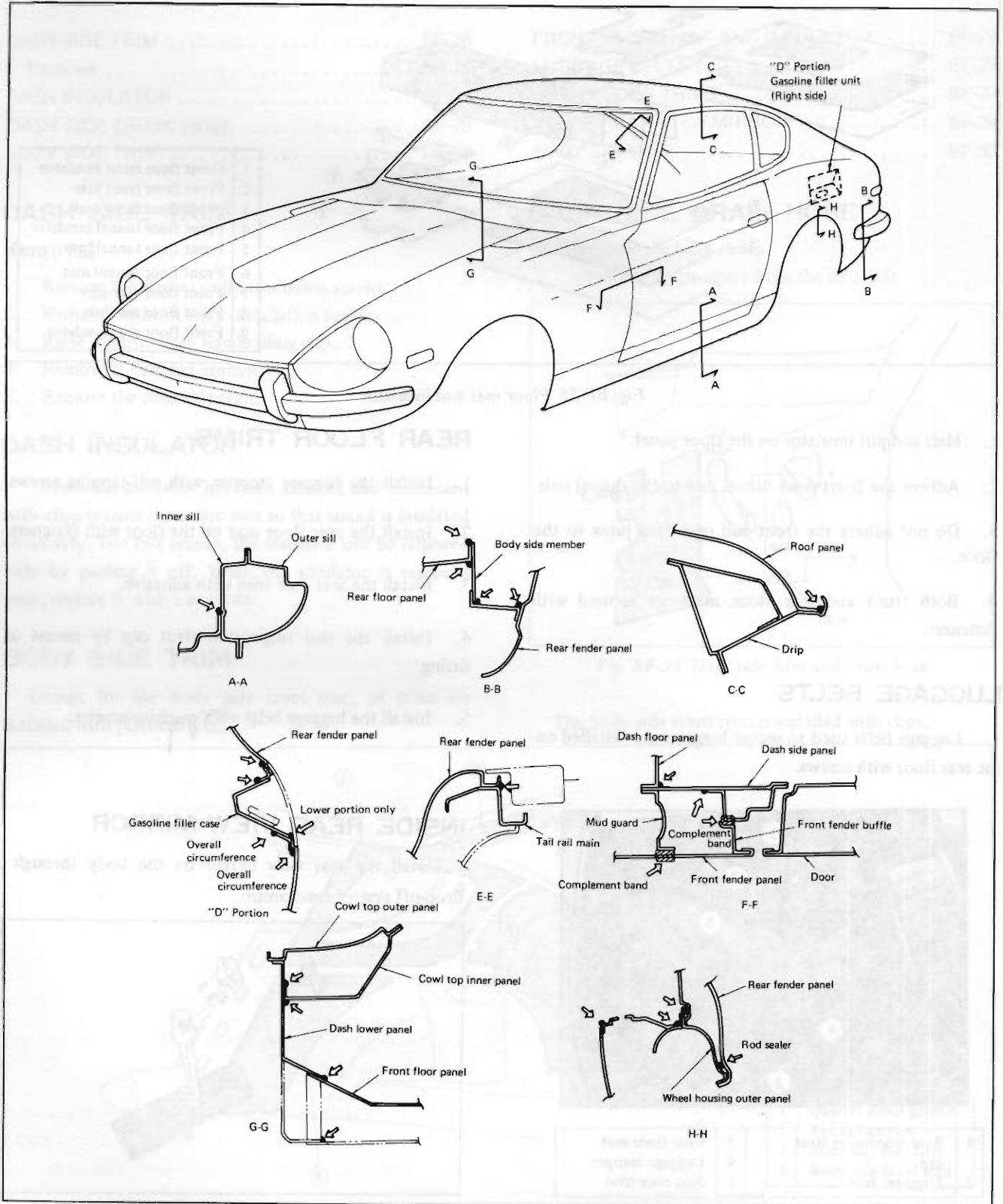

Fig. BF-58 Sealing body panel joint

BODY

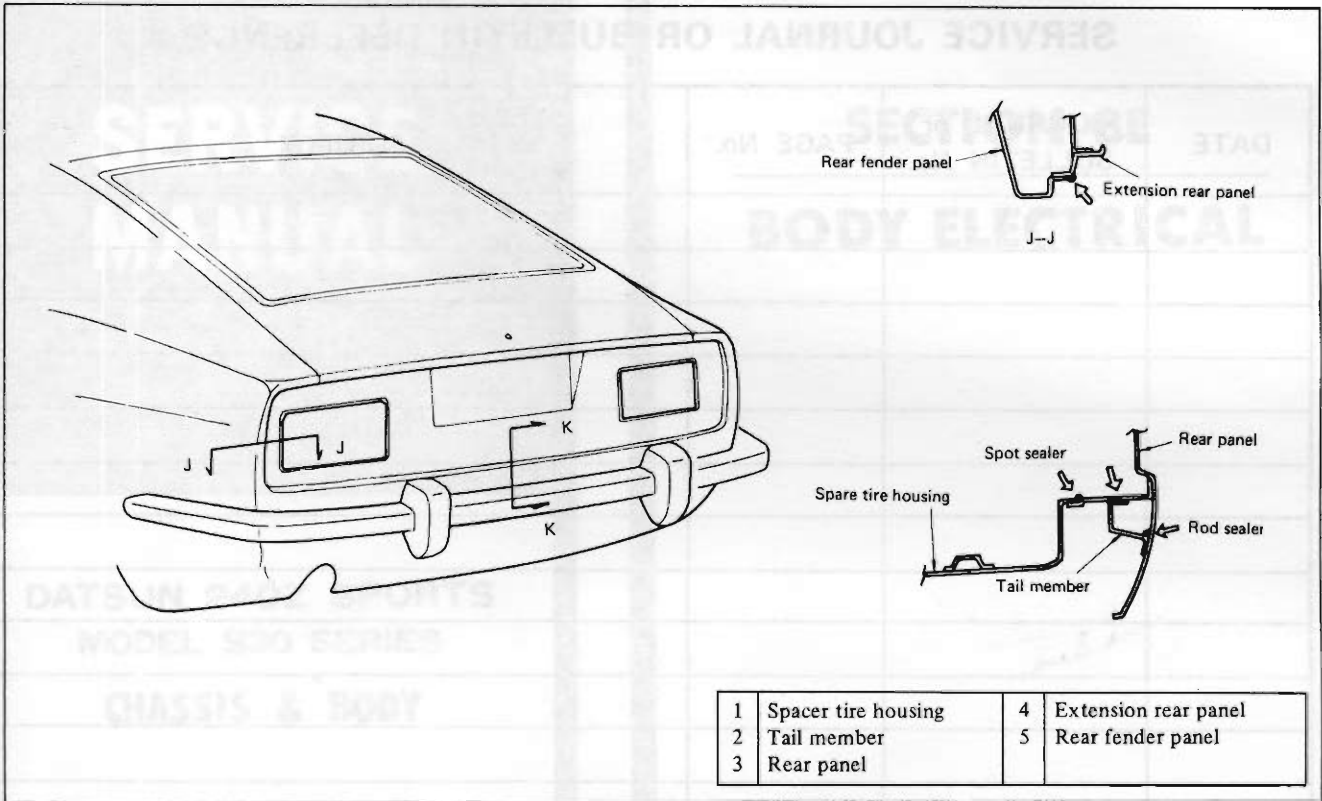

Fig. BF-59 Sealing rear panel joint

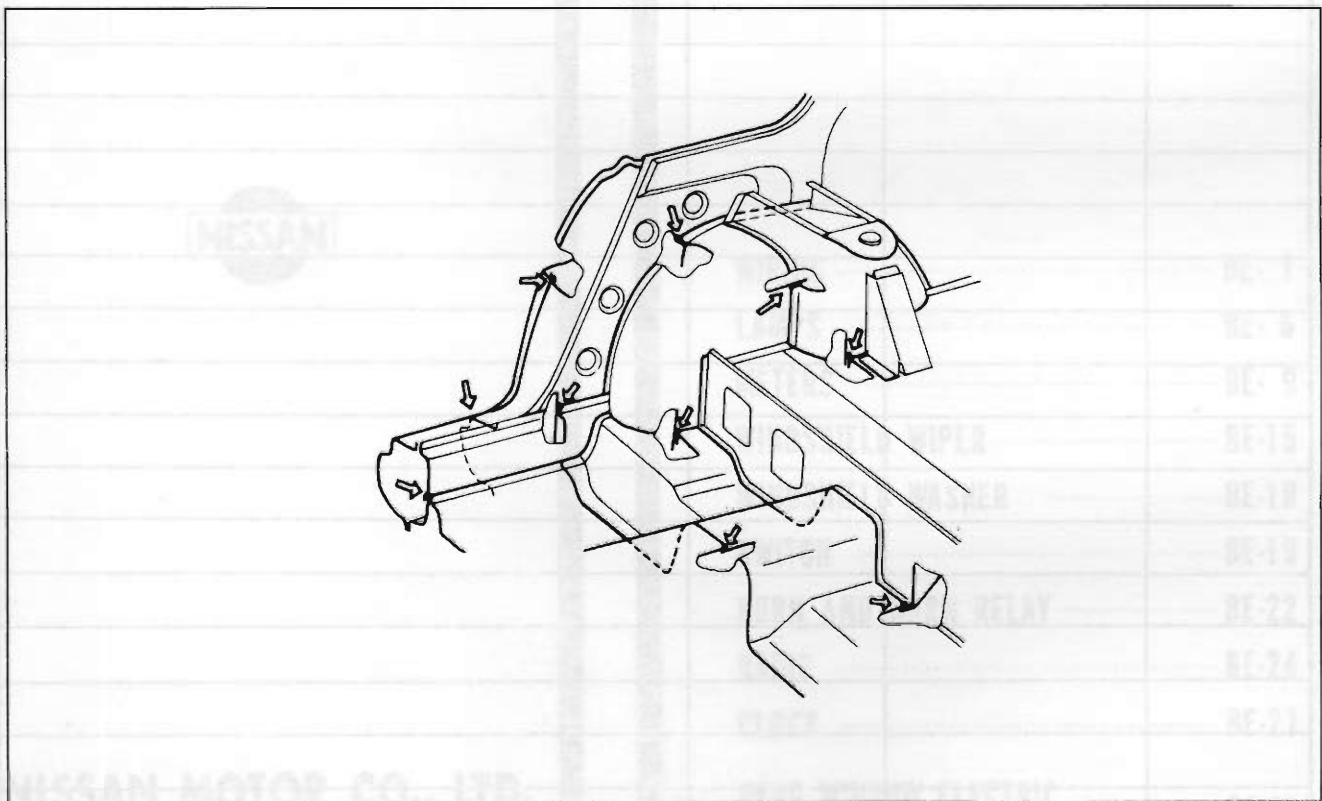

Fig. BF-60 Sealing rear wheel housing

BODY

SERVICE JOURNAL OR BULLETIN REFERENCE

DATE	JOURNAL or BULLETIN No.	PAGE No.	SUBJECT