

SECTION BF

GI
MA
EM
LC
EC
FE
CL
MT
AT
PD
FA
RA
BR
ST
BF
HA
EL
IDX

CONTENTS

GENERAL SERVICING	3	SEAT BELTS	63
Precautions.....	3	Front Seat Belt.....	63
Supplemental Restraint System "AIR BAG".....	3	Rear Seat Belt.....	64
Circuit Breaker Inspection.....	3	SUN ROOF	65
Clip and Fastener	4	Wiring Diagram — SROOF —.....	69
BODY END	7	WINDSHIELD AND WINDOWS	70
Body Front End	7	Windshield and Rear Window	70
Body Rear End and Opener	9	Side Window.....	71
DOOR	11	DOOR MIRROR	72
Door Glass Fitting Adjustment.....	12	Wiring Diagram — MIRROR —.....	73
POWER WINDOW	15	REAR AIR SPOILER	75
System Description.....	15	Rear Air Spoiler.....	75
Wiring Diagram — WINDOW —.....	17	BODY ALIGNMENT	76
Schematic.....	20	Engine Compartment.....	76
Trouble Diagnosis.....	21	Underbody.....	78
POWER DOOR LOCK	27	SUPPLEMENTAL RESTRAINT SYSTEM (SRS)	80
System Description.....	27	Precautions for SRS "Air Bag" Service.....	80
Wiring Diagram — D/LOCK —.....	28	Special Service Tools.....	80
Trouble Diagnosis.....	30	Commercial Service Tool.....	80
MULTI-REMOTE CONTROL SYSTEM	33	Description	81
System Description.....	33	Caution Labels and SRS Component Parts	
Wiring Diagram — MULTI —.....	35	Location.....	82
Schematic.....	38	Maintenance Items.....	84
Input/Output Operation Signal.....	39	Removal and Installation — Diagnosis Sensor	
Trouble Diagnoses.....	40	Unit.....	85
Replacing Remote Controller or Control Unit.....	46	Removal — Air Bag Module and Spiral Cable.....	86
INSTRUMENT PANEL	47	Removal — Front Passenger Air Bag Module.....	87
INTERIOR AND EXTERIOR	50	Installation — Air Bag Module and Spiral	
Interior	50	Cable	88
Exterior	55	Installation — Front Passenger Air Bag	
SEAT	60	Module.....	89
Front Seat.....	60	Disposal of Air Bag Module	89
Rear Seat	62		

CONTENTS (Cont'd.)

TROUBLE DIAGNOSES — Supplemental

Restraint System (SRS)	93
Wiring Diagram — SRS —.....	93
Schematic.....	95
Self-diagnosis.....	96

Diagnostic Procedure 1.....	101
Diagnostic Procedure 2.....	101
Diagnostic Procedure 3.....	102
Collision Diagnosis.....	103

When you read wiring diagrams:

- Read G1 section, "HOW TO READ WIRING DIAGRAMS".
- See EL section, "POWER SUPPLY ROUTING" for power distribution circuit.

When you perform trouble diagnoses, read G1 section, "HOW TO FOLLOW FLOW CHART IN TROUBLE DIAGNOSES" and "HOW TO PERFORM EFFICIENT DIAGNOSIS FOR AN ELECTRICAL INCIDENT".

Precautions

- When removing or installing various parts, place a cloth or padding onto the vehicle body to prevent scratches.
- Handle trim, molding, instruments, grille, etc. carefully during removing or installation. Be careful not to soil or damage them.
- Apply sealing compound where necessary when installing parts.
- When applying sealing compound, be careful that the sealing compound does not protrude from parts.
- When replacing any metal parts (for example body outer panel, members, etc.), be sure to take rust prevention measures.

GI
MA
EM

Supplemental Restraint System "AIR BAG"

The Supplemental Restraint System "Air Bag", used along with a seat belt, helps to reduce the risk or severity of injury to the driver and front passenger in a frontal collision. The Supplemental Restraint System consists of air bag modules (located in the center of the steering wheel and on the instrument panel on the passenger side), a diagnosis sensor unit, warning lamp, wiring harness and spiral cable. Information necessary to service the system safely is included in the **BF** section of this Service Manual.

WARNING:

- **To avoid rendering the SRS inoperative, which could increase the risk of personal injury or death in the event of a collision which would result in air bag inflation, all maintenance must be performed by an authorized NISSAN dealer.**
- **Improper maintenance, including incorrect removal and installation of the SRS, can lead to personal injury caused by unintentional activation of the system.**
- **All SRS air bag electrical wiring harnesses and connectors are covered with yellow outer insulation. Do not use electrical test equipment on any circuit related to the SRS "Air Bag".**

LC
EC
FE
CL
MT
AT

PD
FA

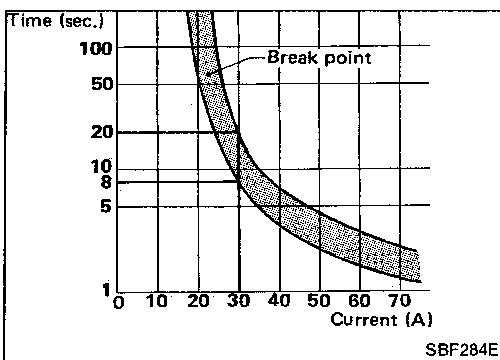

Circuit Breaker Inspection

For example, when current is 30A, the circuit is broken within 8 to 20 seconds.

Circuit breakers are used in the following systems.

- Power window & power door lock
- Power sun roof

RA
BR
ST



BF

HA
EL
IDX

GENERAL SERVICING



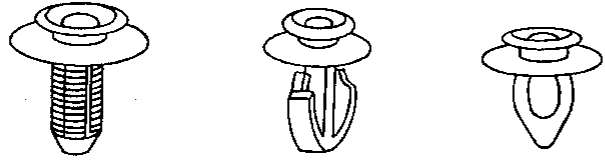
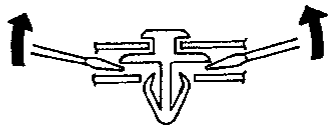

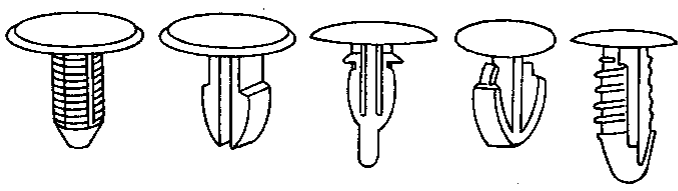
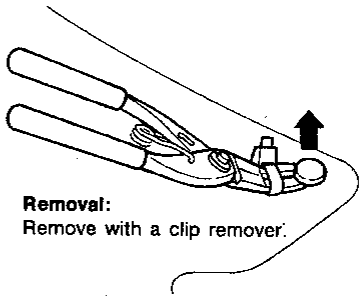
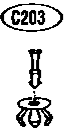
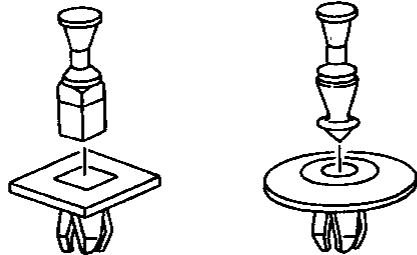
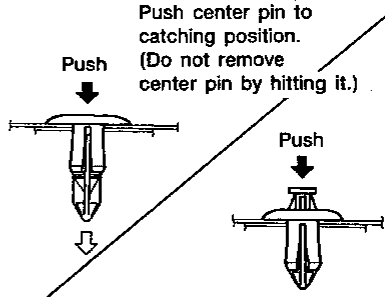
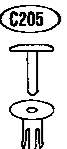
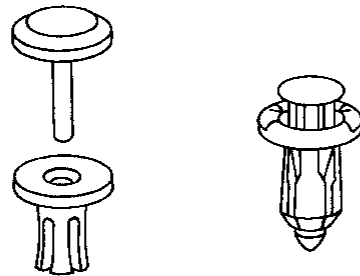
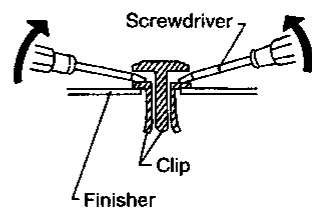

Clip and Fastener

- Clips and fasteners in BF section correspond to the following numbers and symbols.
- Replace any clips and/or fasteners which are damaged during removal or installation.

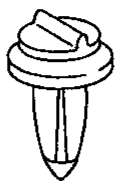
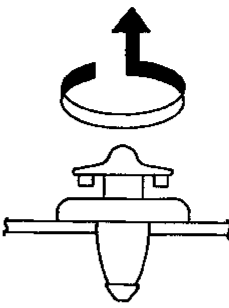
Symbol No.	Shapes	Removal & Installation
	 <p style="text-align: right;">SBF302H</p>	<p>Removal: Remove by bending up with flat-bladed screwdrivers or clip remover.</p>  <p style="text-align: right;">SB0F367BA</p>
	 <p style="text-align: right;">SBF303H</p>	 <p>Removal: Remove with a clip remover.</p> <p style="text-align: right;">SBF304H</p>
	 <p style="text-align: right;">SBF258G</p>	<p>Push center pin to catching position. (Do not remove center pin by hitting it.)</p>  <p style="text-align: right;">Installation: SBF708E</p>
	 <p style="text-align: right;">MBF518B</p>	<p>Removal:</p>  <p style="text-align: right;">SBF638C</p>

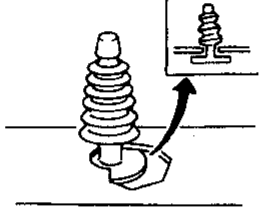
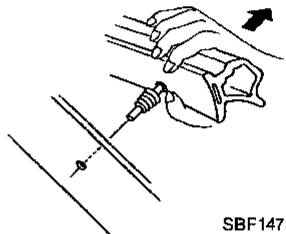
GENERAL SERVICING

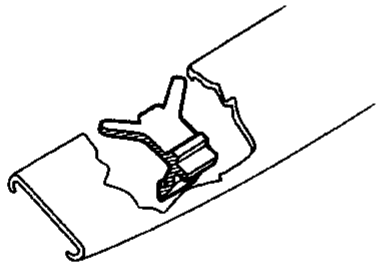
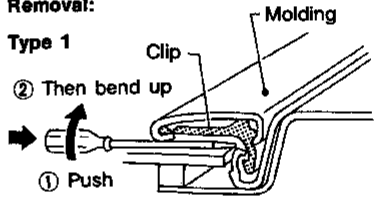
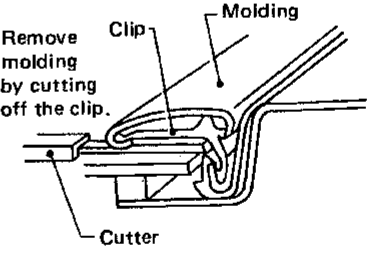
Clip and Fastener (Cont'd)

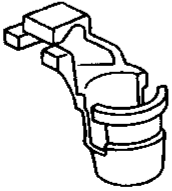
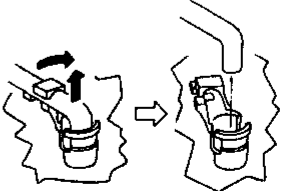
Symbol No.	Shapes	Removal & Installation
		 <p style="text-align: right;">MBF519B</p> <p style="text-align: right;">MBF520B</p>
		<p>Removal:</p>  <p style="text-align: right;">SBF104B</p> <p style="text-align: right;">SBF147B</p>
		<p>Removal:</p> <p>Type 1</p>  <p>② Then bend up</p> <p>① Push</p> <p style="text-align: right;">SBF654B</p> <hr/> <p>Type 2</p> <p>Remove molding by cutting off the clip.</p>  <p style="text-align: right;">SBF653B</p> <p style="text-align: right;">SBF914B</p>
		<p>Removal:</p> <p>Holder portion of clip must be spread out to remove rod.</p>  <p style="text-align: right;">SBF768B</p> <p style="text-align: right;">SBF770B</p>

GI
MA
EM
LC
EC
FE
CL
MT
AT
PD
FA
RA
BR
ST
BF

HA
EL
IDX

GENERAL SERVICING

Clip and Fastener (Cont'd)

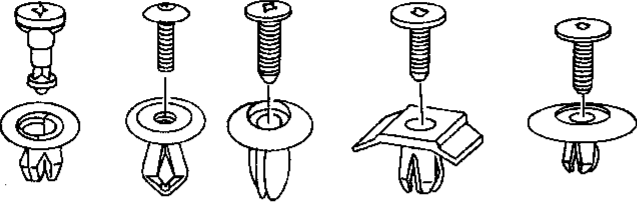
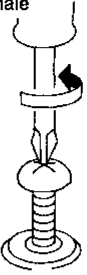
Symbol No.	Shapes	Removal & Installation
	 <p style="text-align: right;">SBF078B</p>	<p>Removal:</p> <ol style="list-style-type: none"> 1. Screw out with a Phillips screwdriver. 2. Remove female portion with flat-bladed screwdriver.  <p style="text-align: right;">SBF992G</p>

BODY END

Body Front End

- When removing or installing hood, place a cloth or other padding on hood. This prevents vehicle body from being scratched.
- Bumper fascia is made of plastic. Do not use excessive force and be sure to keep oil away from it.
- Hood adjustment: Adjust at hinge portion. GI
- Hood lock adjustment: After adjusting, check hood lock control operation. Apply a coat of grease to hood locks engaging mechanism. MA
- Hood opener: Do not attempt to bend cable forcibly. Doing so increases effort required to unlock hood.

REMOVAL — Front bumper assembly

- ① Remove nuts securing bumper fascia to front air spoiler. EM
- ② Remove clips (C203) and screws left and right side of fender protector front. LC
- ③ Remove bolts securing bumper fascia to engine undercover. EC
- ④ Remove clips (CS101) securing front grille. FE
- ⑤ Remove screws securing each side of clearance lamp.
- ⑥ Remove clip (C205) securing hood lock stay to bumper fascia. CL
- ⑦ Remove fog lamp cover. Remove bolts securing fog lamp assembly.
- ⑧ Remove bolts and nuts securing headlamps. MT
- ⑨ Remove left and right screws securing bumper fascia to fender. AT
- ⑩ Remove left and right bolts securing bumper fascia to bumper side bracket. PD
- ⑪ Remove bolts securing bumper fascia bracket to bumper fascia. FA
- ⑫ Remove bumper fascia assembly. RA
- ⑬ Remove energy absorber. BR
- ⑭ Remove left and right nuts securing bumper fascia bracket to radiator core support side. ST
- ⑮ Remove bolts and nuts securing bumper stay to bumper bracket. BF
- ⑯ Remove bumper reinforcement assembly. HA

Body Rear End and Opener

- When removing or installing trunk lid, place a cloth or other padding on trunk lid. This prevents vehicle body from being scratched.
- Trunk lid adjustment: Adjust at hinge-trunk lid portion for proper trunk lid fit.
- Trunk lid lock system adjustment: Adjust striker so that it is in the center of the lock. After adjustment, check trunk lid lock operation.
- Opener cable: do not attempt to bend cable using excessive force.
- After installation, make sure that trunk lid and fuel filler lid open smoothly.

GI

MA

EM

LC

EC

FE

CL

MT

AT

PD

FA

RA

BR

ST

BF

HA

EL

IDX

REMOVAL — Rear bumper assembly

- ① Remove screws from lower side of each side bumper.
- ② Remove clips **CS101** from lower side of bumper fascia.
- ③ Remove clips **C205** from upper side of bumper fascia.
- ④ Remove screws and clip **C203** securing license plate to bumper fascia.
- ⑤ Remove trunk trim. Refer to "LUGGAGE ROOM TRIM" in "Interior" for details.
- ⑥ Working inside trunk, remove nuts securing left and right rear fenders to bumper fascia.
- ⑦ Working inside trunk, remove nuts securing left and right rear panels to bumper fascia.
- ⑧ Remove bumper fascia assembly.
- ⑨ Working inside trunk, remove left and right plugs from floor, then remove bolts.
- ⑩ Remove bumper reinforcement.

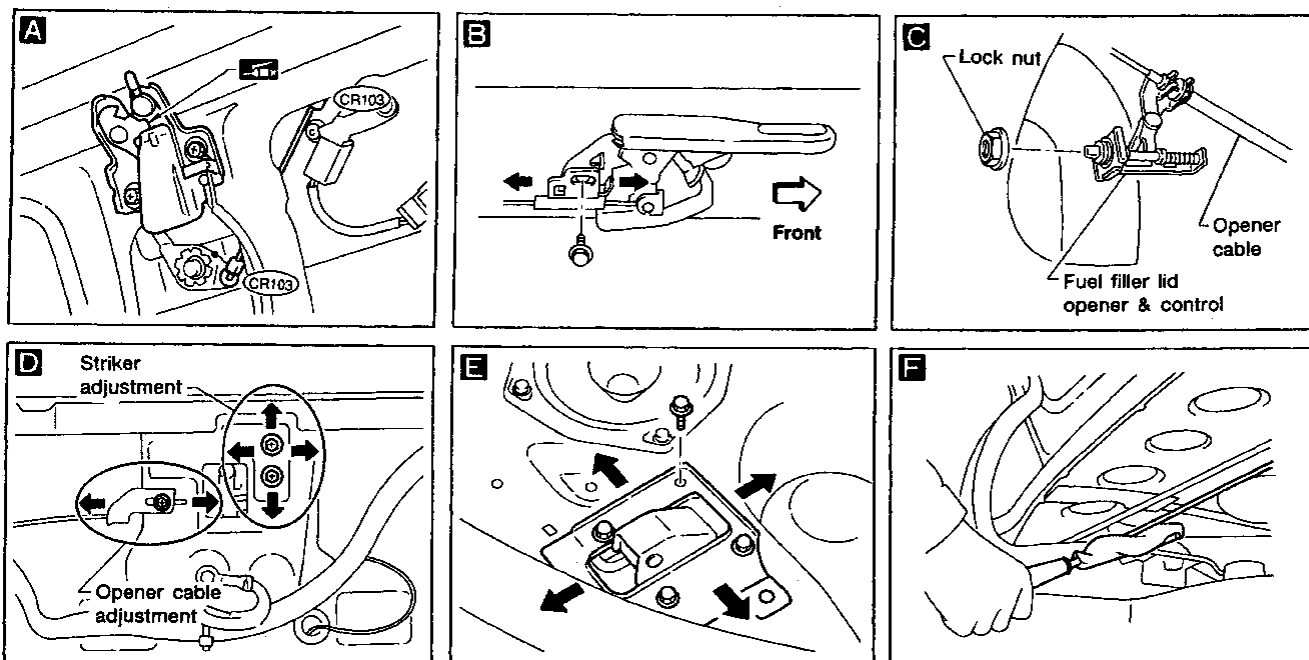

BODY END

Body Rear End and Opener (Cont'd)

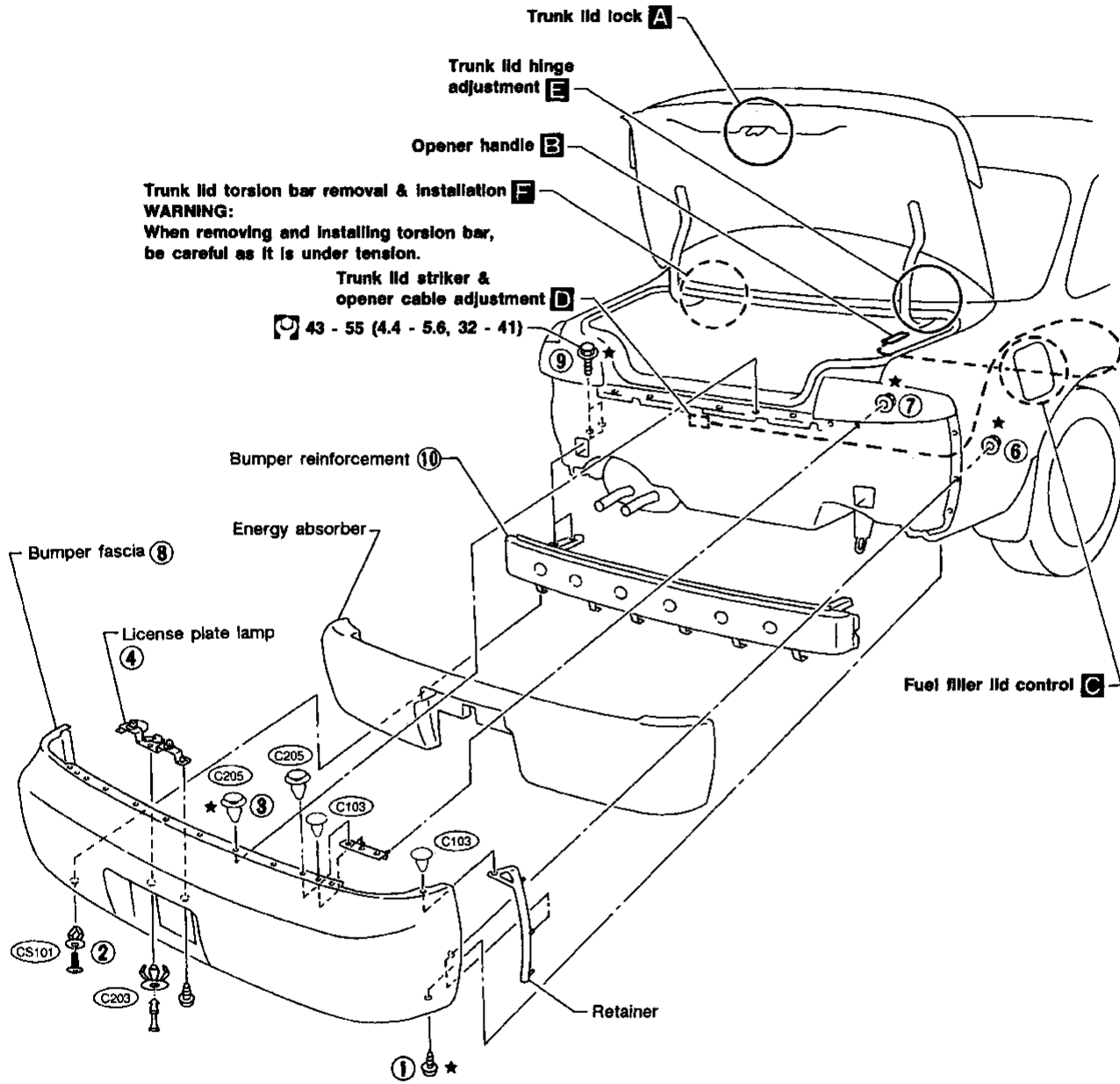

Trunk lid torsion bar removal & installation **F**
WARNING:
 When removing and installing torsion bar,
 be careful as it is under tension.

Trunk lid striker & opener cable adjustment **D**
 43 - 55 (4.4 - 5.6, 32 - 41)

★ : Bumper assembly mounting bolts, nuts and clips
 [C] : N·m (kg-m, ft-lb)

SEC. 843-850

MBF442B

DOOR

- For removal of door trim, refer to "DOOR TRIM" (BF-52).
- After adjusting door or door lock, check door lock operation.

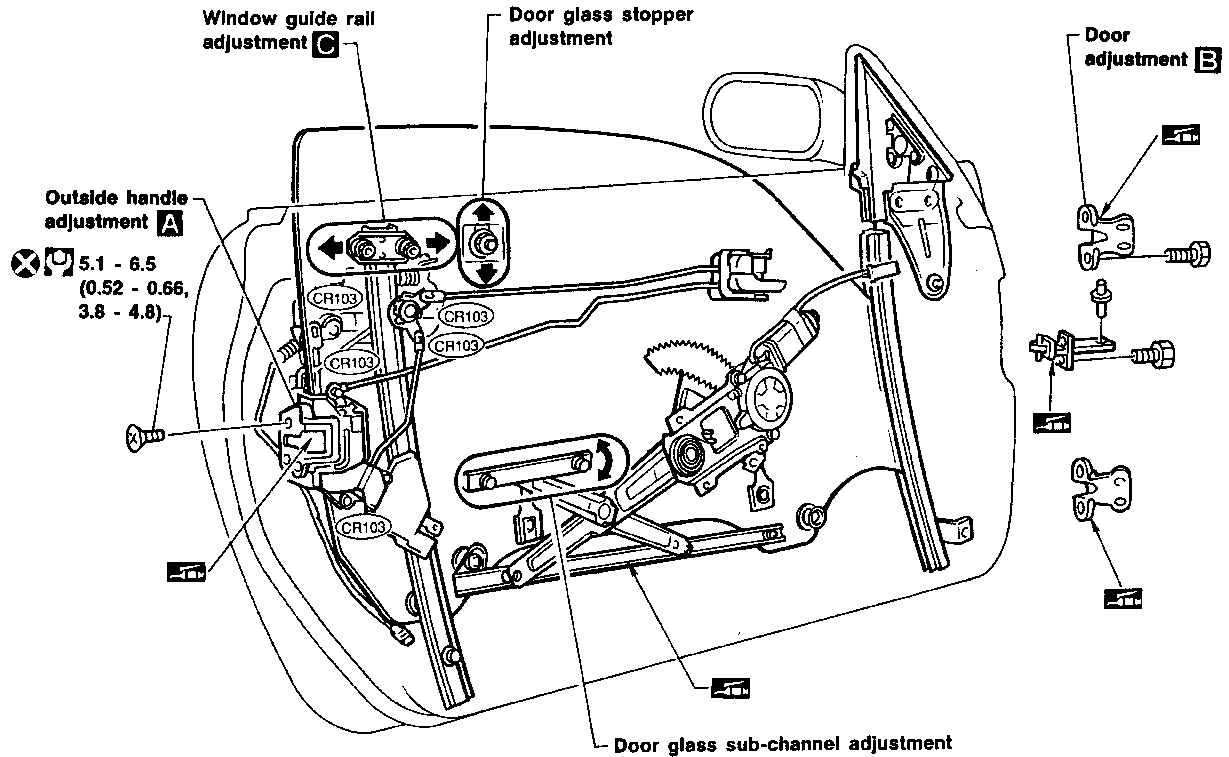

SEC. 800-803-805

: N·m (kg-m, ft-lb)

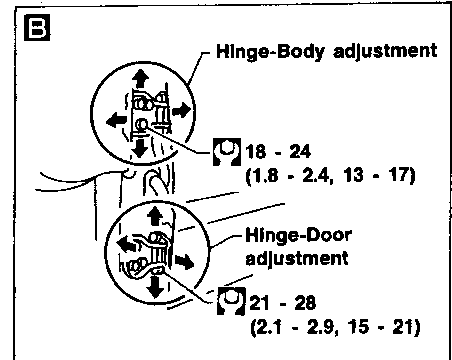
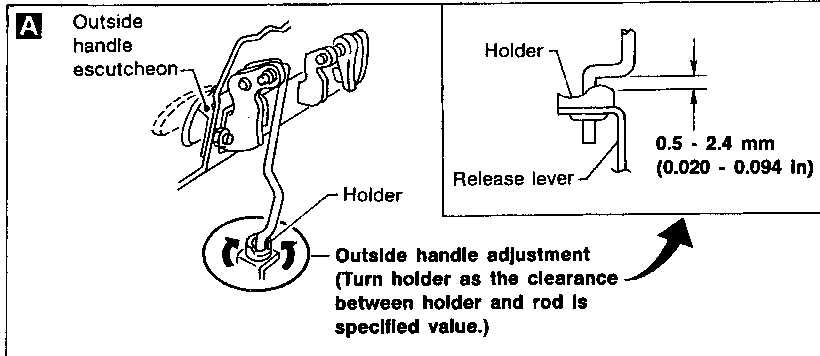

Striker adjustment

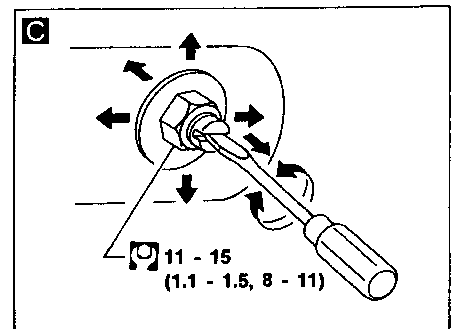
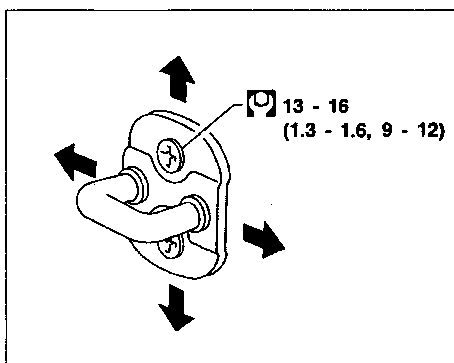

GI
MA
EM
LC
EC
FE
CL
MT
AT
PD
FA
RA
BR
ST
BF
HA
EL
IDX

DOOR

Door Glass Fitting Adjustment

The door glass is properly adjusted using the following five methods:

- A** In-out adjustment (at the glass waist)
- B** Fore-aft tilt adjustment
- C** In-out tilt adjustment (at the glass upper stop)
- D** Up-stop adjustment
- E** Fore-aft adjustment

NOTICE:

When adjusting the door glass, it is not necessary to remove the outside door molding.

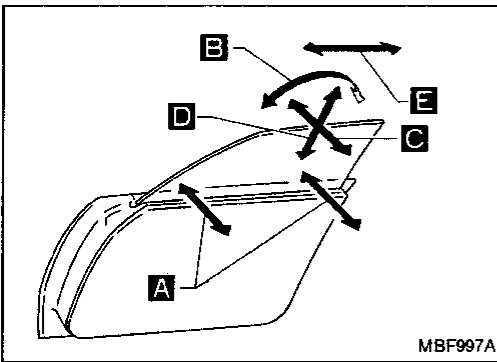

MBF997A

Adjustment locations

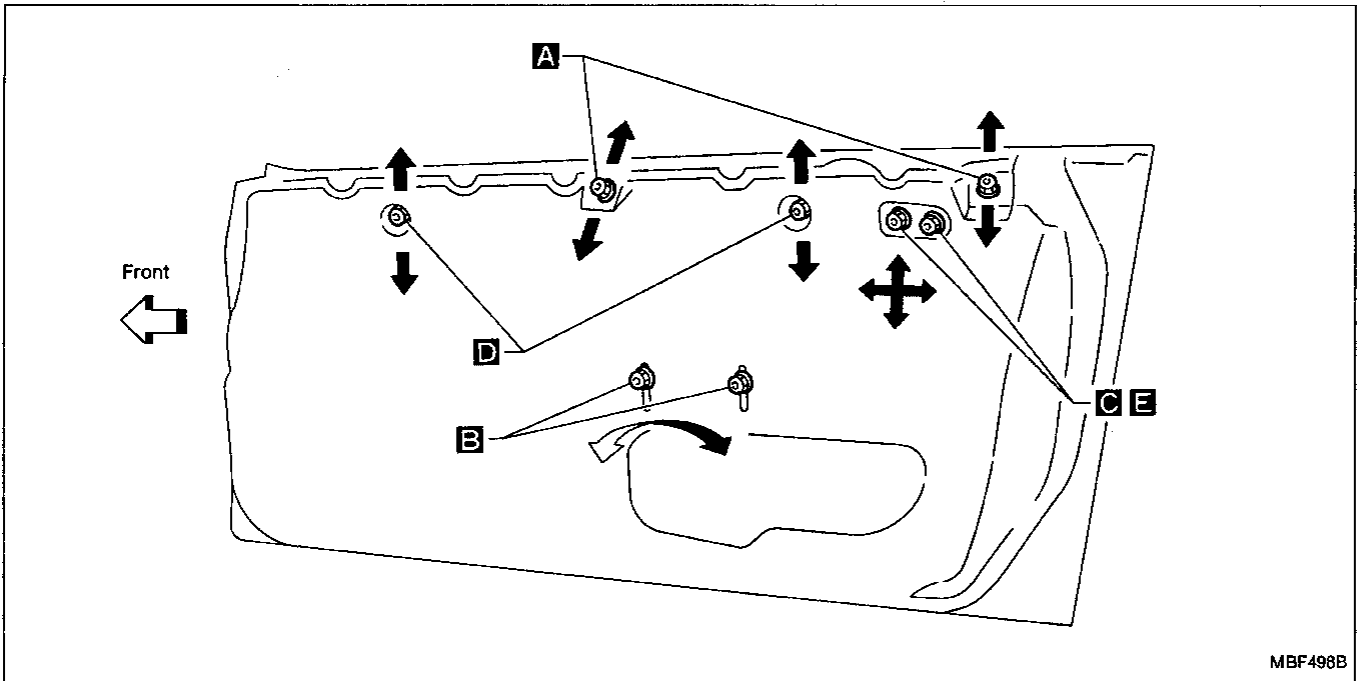

MBF498B

Adjustment standard clearance

SEC. 803

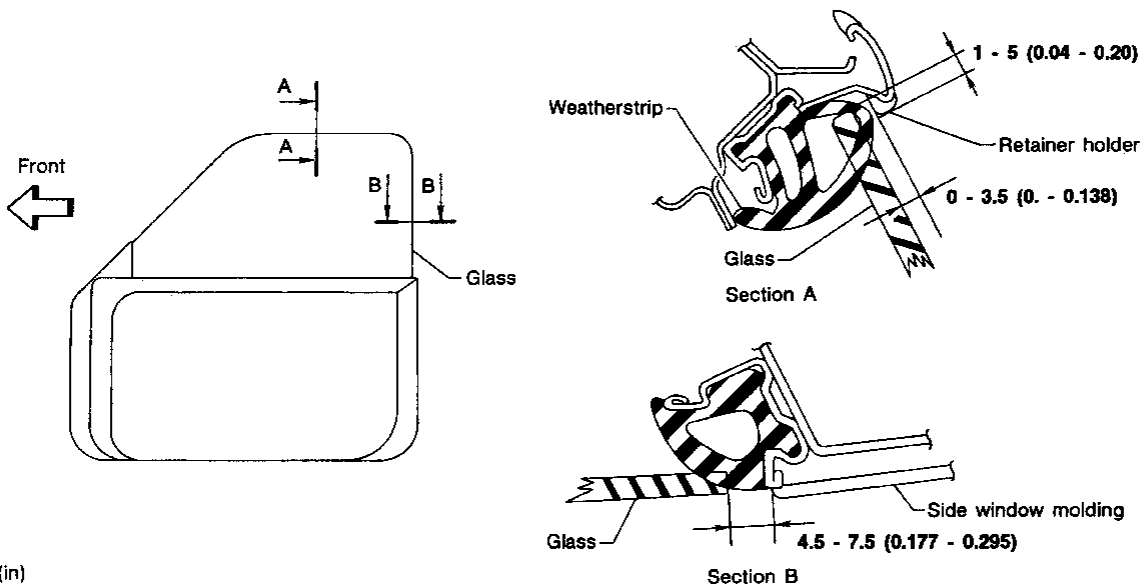

Unit: mm (in)

SBF394H

DOOR

Door Glass Fitting Adjustment (Cont'd)

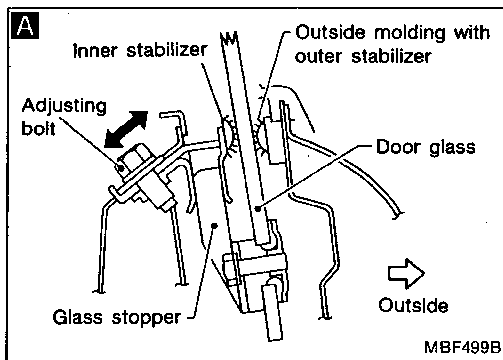

A IN-OUT ADJUSTMENT (at the glass waist)

1. Raise door glass until glass stopper is in contact with inner stabilizer, just before the window stops.
2. Loosen adjusting bolts.
3. Lightly press door glass upper end outward so that glass outer surface contacts outer stabilizer. With glass held in that position, press inner stabilizer to glass inner surface and tighten adjusting bolt.

CAUTION:

Make sure nap portions of stabilizers are clean and free from oil, grease, etc.

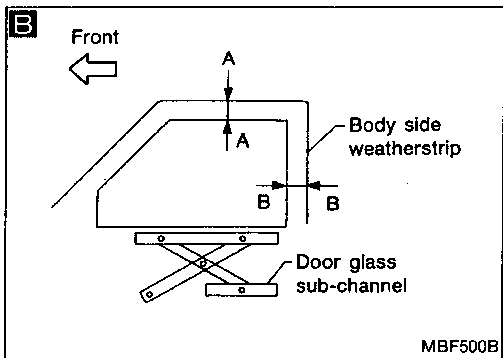

B FORE-AFT TILT ADJUSTMENT

- Adjust front glass sub-channel so that specified dimensions A-A and B-B are obtained at the glass and retainer holder/body side weatherstrip location.

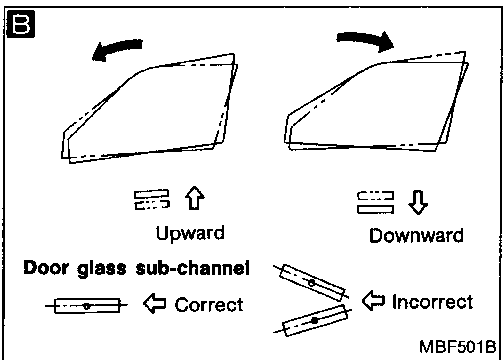

- For sub-channel adjustment procedures, refer to figure at left as a guide.

CAUTION:

- Make sure door glass sub-channel is horizontal.
- The fore-aft tilt adjustment must be made at the same time the fore-aft adjustment **E** is made.

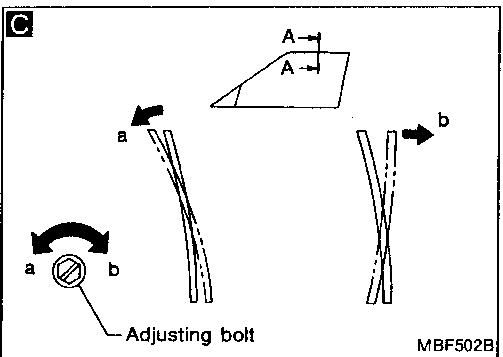

C IN-OUT TILT ADJUSTMENT (at glass upper stop)

1. Adjust door glass-to-holder clearance to 0 - 3.5 mm (0 - 0.138 in) (A) with the adjusting bolts.

CAUTION:

- Turn adjusting bolt clockwise to move door glass upper end outward.
- Turn adjusting bolt counterclockwise to move door glass upper end inward.

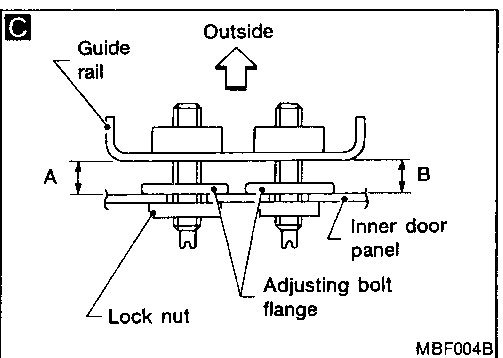

- For sub-channel adjustment procedures, refer to figure at left as a guide.

CAUTION:

- Make sure door glass sub-channel is horizontal.
- The fore-aft tilt adjustment must be made at the same time the fore-aft adjustment **E** is made.

DOOR

Door Glass Fitting Adjustment (Cont'd)

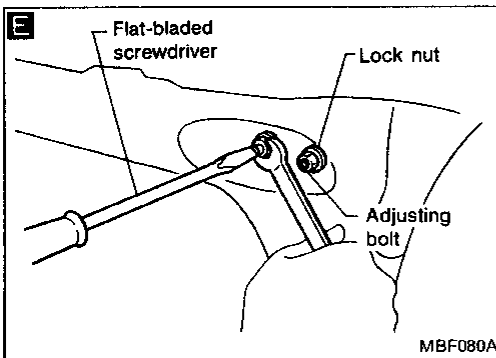
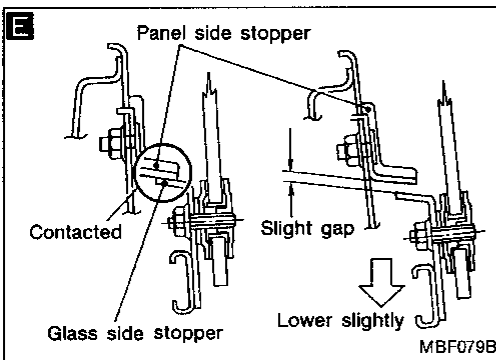
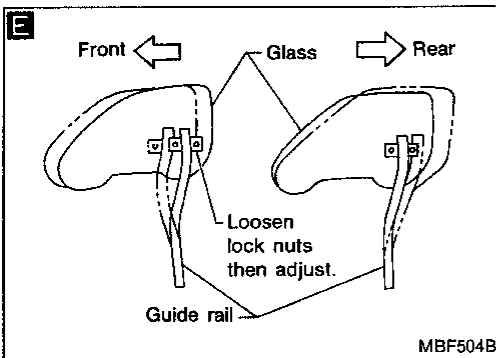
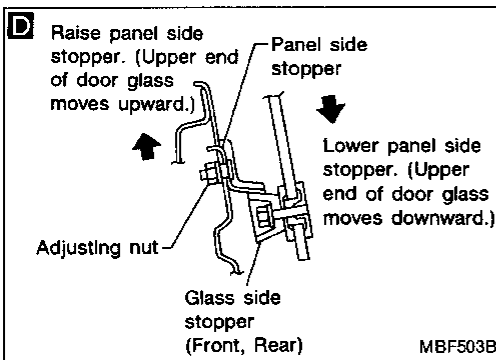

D UP-STOP ADJUSTMENT

1. Adjust panel stopper height so that clearance at upper edge of door is standard measurement (A). Make sure front and rear glass stoppers lightly contact front and rear panel stoppers, then tighten adjusting nuts.
2. If stoppers do not contact each other, adjust sub-channel nut. Refer to "**E** Fore-aft tilt adjustment".
3. Open and close doors to make sure upper end of door glass does not contact holder.

E FORE-AFT ADJUSTMENT

1. Adjust guide rail in the fore-aft direction so that clearance between upper edge of door glass and holder is constant at the midpoint of holder (specified dimension A) when door is closed or opened.
2. If outer perimeter of door glass interferes with holder when door is opened or closed, refer to "**E** Fore-aft tilt adjustment" for procedures.

CAUTION:

When loosening guide rail lock nut, prevent adjusting bolt from turning by holding it with a standard screwdriver.

3. Lower the glass slightly until the glass side stopper comes off the panel side stopper.

CAUTION:

Do not lower the glass excessively.

- After completing door glass adjustment, retighten all lock nuts.

CAUTION:

While tightening lock nuts, hold adjusting bolts using a standard screwdriver to prevent them from turning.

System Description

Power is supplied at all times

- from 25A fusible link (Letter **I** located in the fuse and fusible link box)
- to circuit breaker terminal **①**
- through circuit breaker terminal **②**
- to power window relay terminal **③**.

With ignition switch in ON or START position, power is supplied

- through 7.5A fuse (No. **1** located in the fuse block)
- to power window relay terminal **①**.

Ground is supplied to power window relay terminal **②**

- through body ground **(MS)**.

The power window relay is energized and power is supplied

- through power window relay terminal **⑤**
- to power window main switch terminal **⑤**,
- to power window sub switch terminal **④**,
- to power window amplifier terminal **③** and
- to power window amplifier terminal **④**.

GI

MA

EM

LC

EC

FE

MANUAL OPERATION

Door LH

Ground is supplied

- to power window main switch terminal **④** and
- to power window amplifier terminal **⑦**
- through body ground **(MS)**.

CL

MT

WINDOW UP

When the LH switch in the power window main switch is pressed in the up position, ground signal is supplied

- to power window amplifier terminal **①**
- from power window main switch terminal **③**.

Power is supplied

- to power window regulator LH terminal **①**
- through power window amplifier terminal **⑤**.

Ground is supplied

- to power window regulator LH terminal **②**
- through power window amplifier terminal **⑥**.

Then, the motor raises the window until the switch is released.

AT

PD

FA

RA

BR

WINDOW DOWN

When the LH switch in the power window main switch is pressed in the down position, ground signal is supplied

- to power window amplifier terminal **②**
- from power window main switch terminal **②**.

Power is supplied

- to power window regulator LH terminal **②**
- through power window amplifier terminal **⑥**.

Ground is supplied

- to power window regulator LH terminal **①**
- through power window amplifier terminal **⑤**.

Then, the motor lowers the window until the switch is released.

ST

BF

HA

EL

IDX

Door RH

Ground is supplied

- to power window main switch terminal **④**
- through body ground **(MS)**.

POWER WINDOW

System Description (Cont'd)

NOTE:

Numbers in parentheses are terminal numbers, when power window switch is pressed in the UP and DOWN positions respectively.

Main switch operation

Power is supplied

- through power window main switch (⑦, ⑥)
- to power window sub-switch (⑤, ①).

The subsequent operation is the same as the sub-switch operation.

Sub-switch operation

Power is supplied

- through power window sub-switch (②, ③)
- to power window regulator RH (①, ②).

Ground is supplied

- to power window regulator RH (②, ①)
- through power window sub-switch (③, ②)
- to power window sub-switch (⑤, ①)
- through power window main switch (⑦, ⑥).

Then, the motor raises or lowers the window until the switch is released.

AUTO OPERATION

The power window AUTO feature enables the driver to lower the driver's window without holding the window switch in the down position.

The AUTO feature only operates on the driver's window downward movement.

When a power window main switch is pressed and released the AUTO position, ground signal is supplied

- to power window amplifier terminal ⑧
- from power window main switch terminal ①.

The subsequent operation is the same as the manual operation of door LH.

Then, the door LH window will fully open.

POWER WINDOW LOCK

The power window lock is designed to lock-out window operation to door RH window.

When the lock switch is pressed to lock position, ground of the RH switch in the power window main switch is disconnected. This prevents the power window motors from operating.

POWER WINDOW

Wiring Diagram — WINDOW —

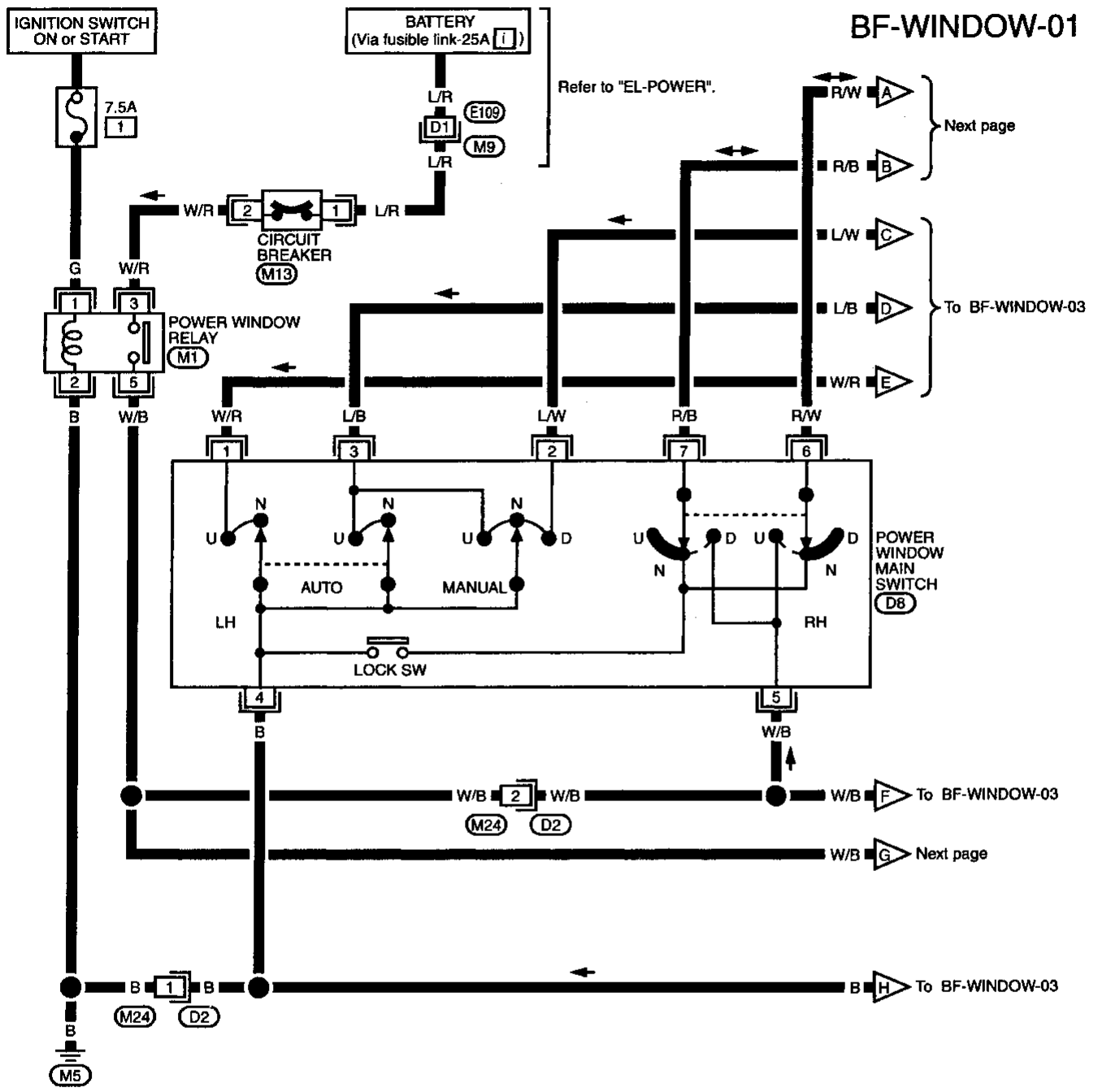

GI
MA
EM
LC
EC
FE
CL
MT
AT
PD
FA
RA
BR
ST
BF

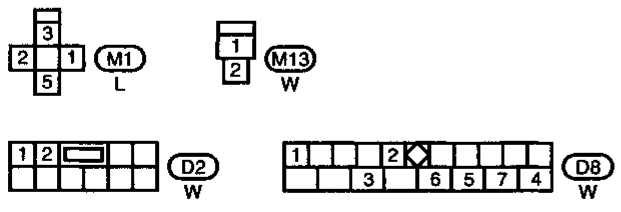

Refer to last page (Foldout page).
M9, E109

HA
EL
IDX

POWER WINDOW

Wiring Diagram — WINDOW — (Cont'd)

BF-WINDOW-03

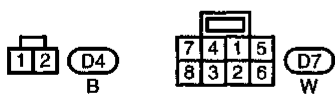
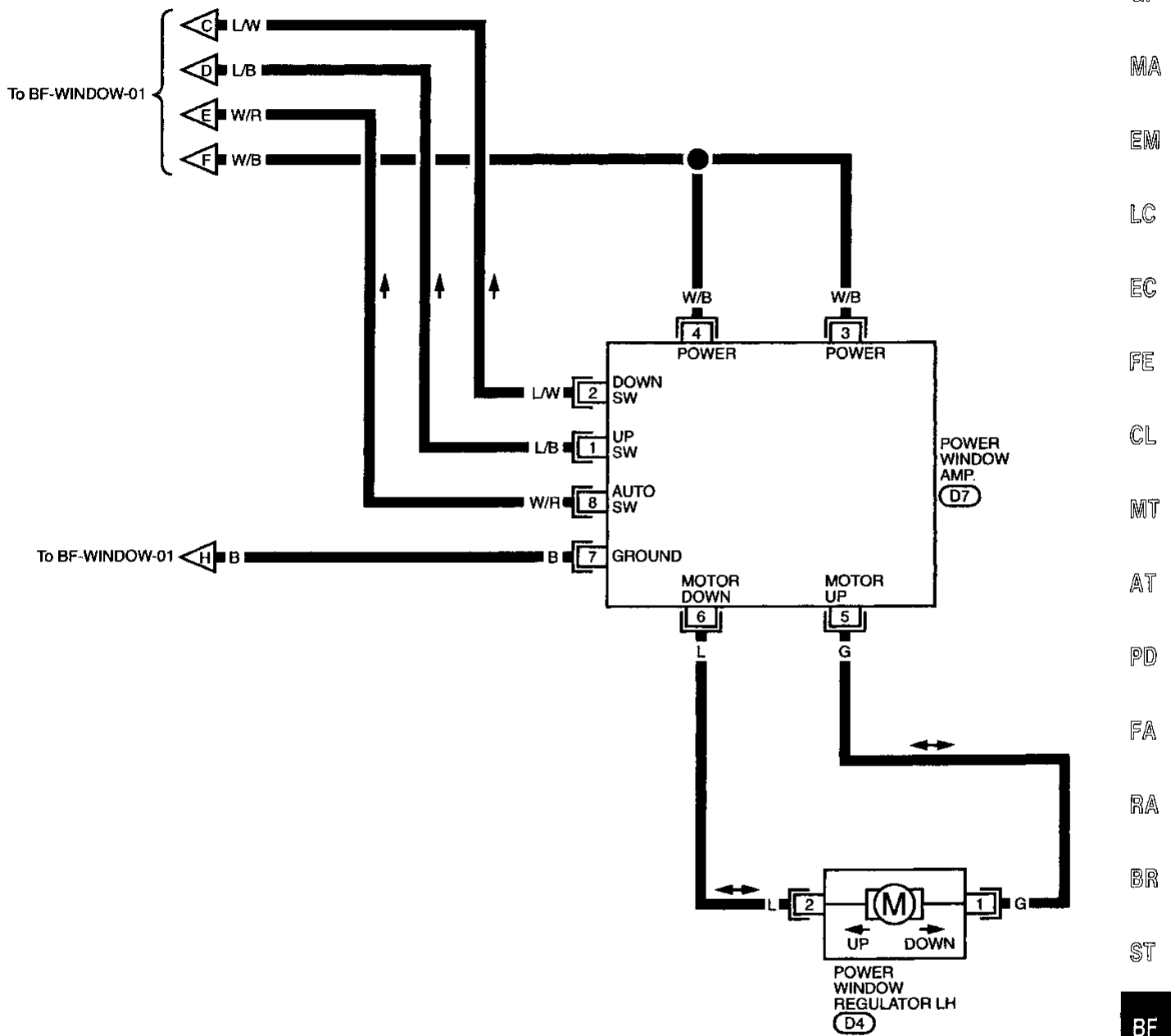

GI
MA
EM
LC
EC
FE
CL
MT
AT
PD
FA
RA
BR
ST
BF

HA
EL
IDX

POWER WINDOW

Schematic

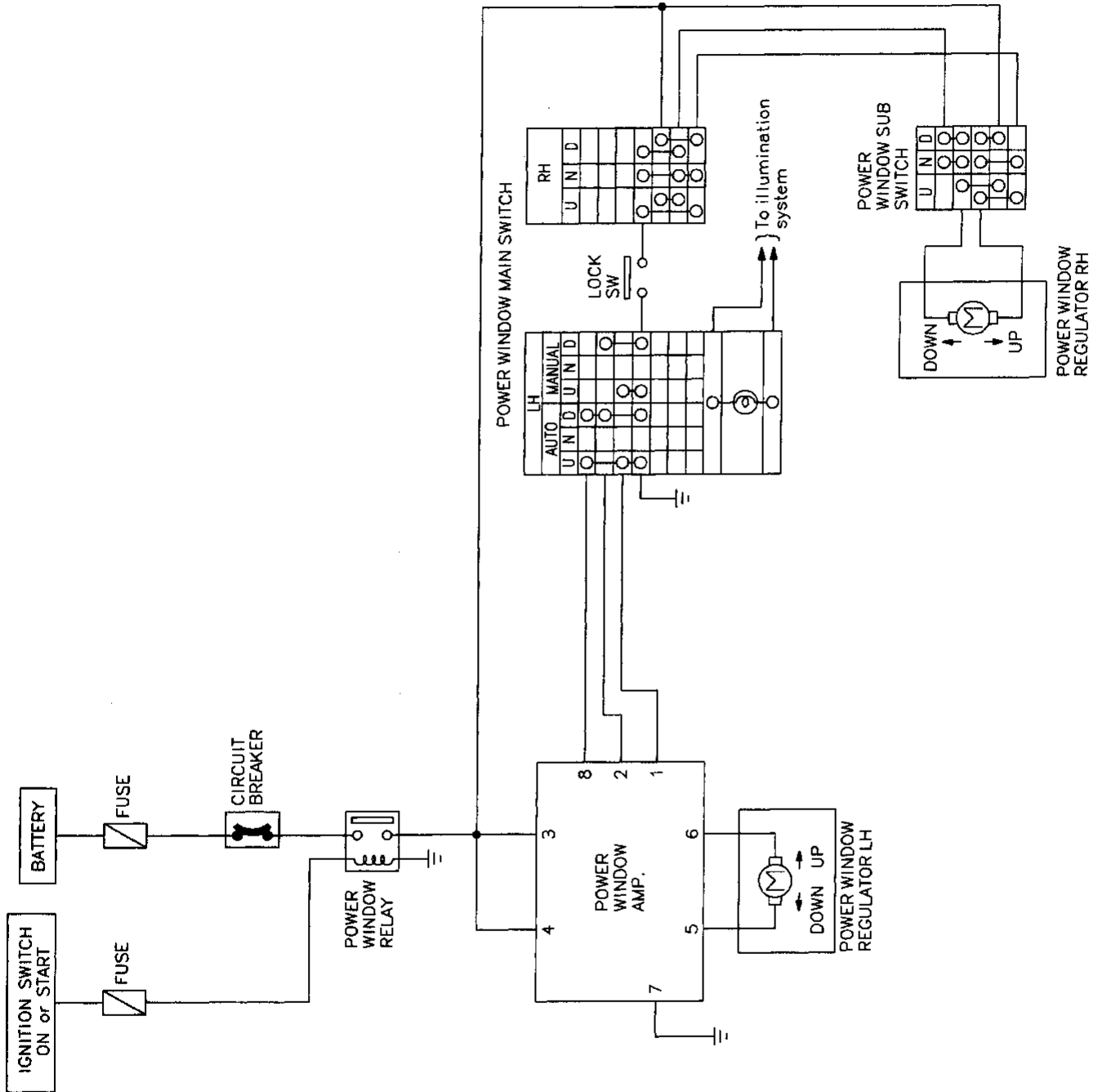

POWER WINDOW

Trouble Diagnosis

SYMPTOM CHART

Procedure	Main Power Supply and Ground Circuit Check		Diagnostic Procedure		Electrical Components Inspection
	BF-21	BF-22	BF-23	BF-24	BF-26
Reference page					
SYMPTOM	Procedure 1	Procedure 2	Procedure 1	Procedure 2	Power window motor(s)
All power window (P/W) cannot be operated.	○	○	○	○	○
Driver's power window cannot be operated but passenger power window can be operated.			○		○
Passenger power window (main switch and/or passenger switch) cannot be operated but driver's power window can be operated.				○	○
Passenger power window does not lock using lock button of main switch. But passenger power window can be operated.	Replace power window main switch.				

GI
MA
EM
LC
EC
FE
CL
MT
AT
PD
FA
RA
BR
ST
BF
HA
EL
IDX

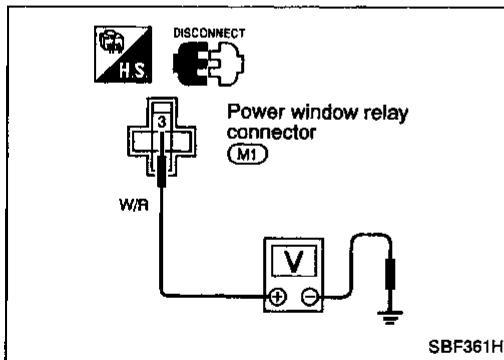

MAIN POWER SUPPLY AND GROUND CIRCUIT CHECK

PROCEDURE 1

Main power supply for P/W relay

Terminals	Battery voltage existence
③ - Ground	Yes

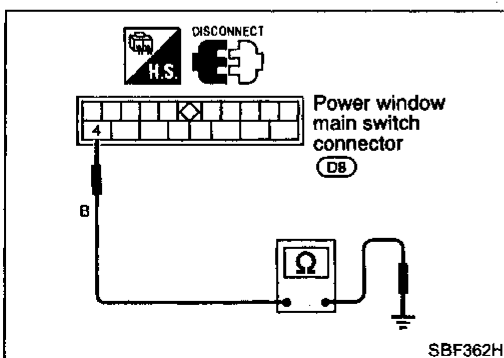

Ground circuit for P/W main switch

Terminals	Continuity
④ - Ground	Yes

POWER WINDOW

Trouble Diagnosis (Cont'd)

PROCEDURE 2

Power supply for ignition signal

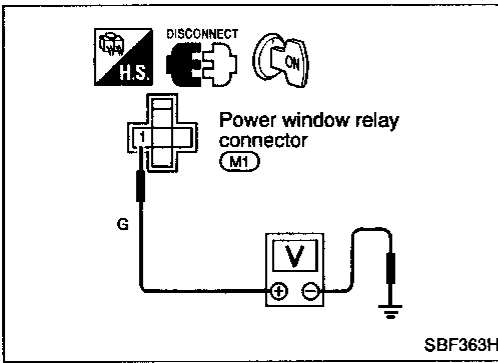

Terminals	Ignition switch	Battery voltage existence
① - Ground	ON	Yes

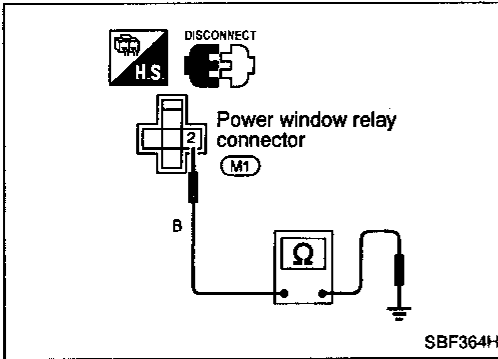

Ground circuit for power window relay

Terminals	Continuity
② - Ground	Yes

POWER WINDOW

Trouble Diagnosis (Cont'd)

DIAGNOSTIC PROCEDURE 1

SYMPTOM: Driver's power window cannot be operated but passenger power window can be operated.

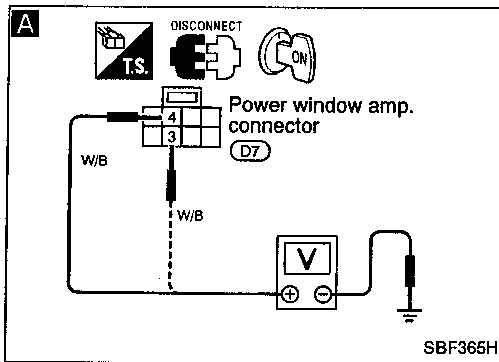

A

CHECK POWER SUPPLY FOR POWER WINDOW AMP.

- 1) Disconnect connector from power window amp.
- 2) Check voltage across power window amp. terminal ③ and GND, ④ AND GND while ignition switch is "ON".

Terminals	Battery voltage existence
③ - GND	Yes
④ - GND	

NG

Check the following items.

- 1) Harness continuity between power window relay and power window amp.
- 2) Power window relay

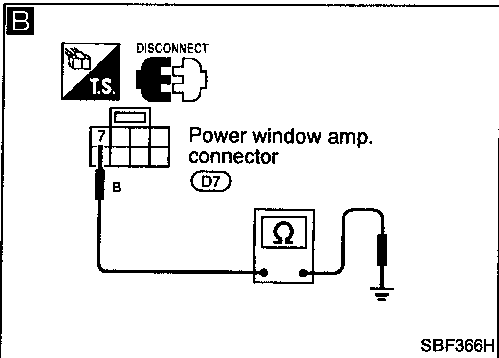

B

CHECK GROUND CIRCUIT FOR POWER WINDOW AMP.

Check continuity between power window amp. terminal ⑦ and GND.

Does continuity exist?

No

Repair harness.

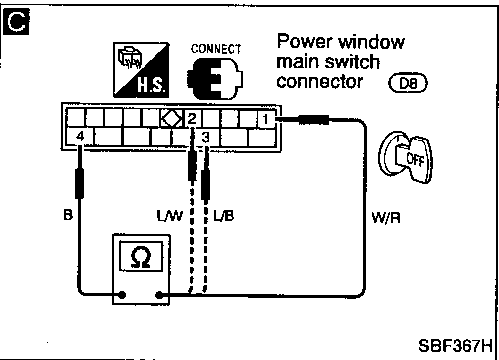

C

CHECK POWER WINDOW MAIN SWITCH CIRCUIT.

- 1) Disconnect connector from power window main switch.
- 2) Check continuity.

	Terminals
Auto (Down)	① - ④
Up	③ - ④
Down	② - ④

Does continuity exist?

No

Replace power window main switch.

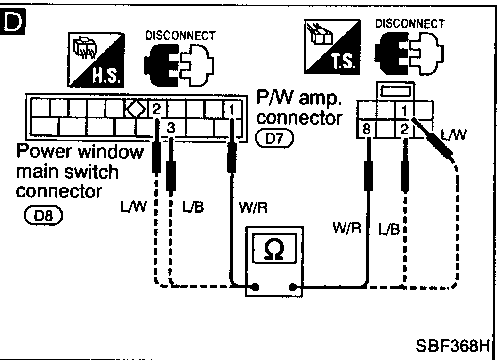

D

- 1) Disconnect connector from power window amp. connector.
- 2) Check continuity.

	Terminals
Auto (Down)	① - ⑧
Up	③ - ①
Down	② - ②

Does continuity exist?

No

Repair harness.

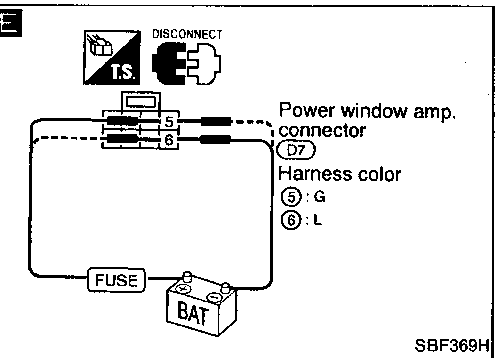

E

CHECK POWER WINDOW MOTOR CIRCUIT.

Check power window operation.

Terminals		Window
⊕	⊖	
⑤	⑥	Up
⑥	⑤	Down

OK

Replace power window amp.

NG

(Go to next page.)

GI
MA
EM
LC
EC
FE
CL
MT
AT
PD
FA
RA
BR
ST
BF
HA
EL
IDX

POWER WINDOW

Trouble Diagnosis (Cont'd)

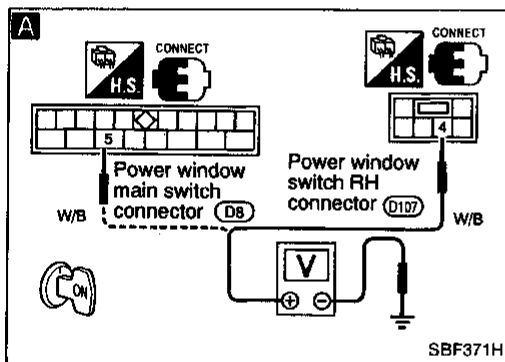
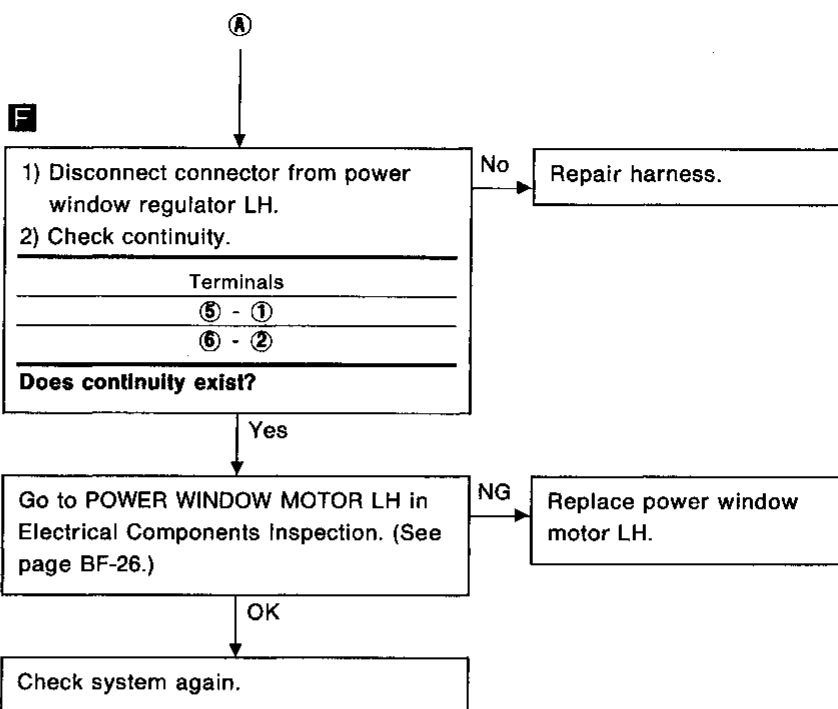
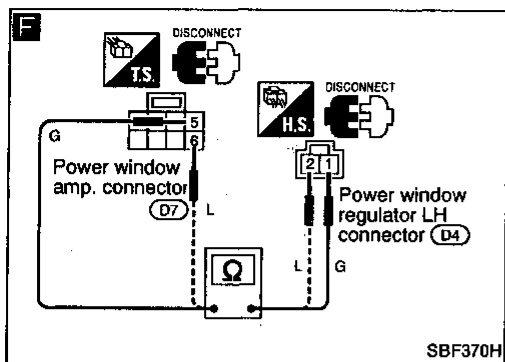

DIAGNOSTIC PROCEDURE 2

SYMPTOM: Passenger power window (main switch and/or passenger switch) cannot be operated but driver's power window can be operated.

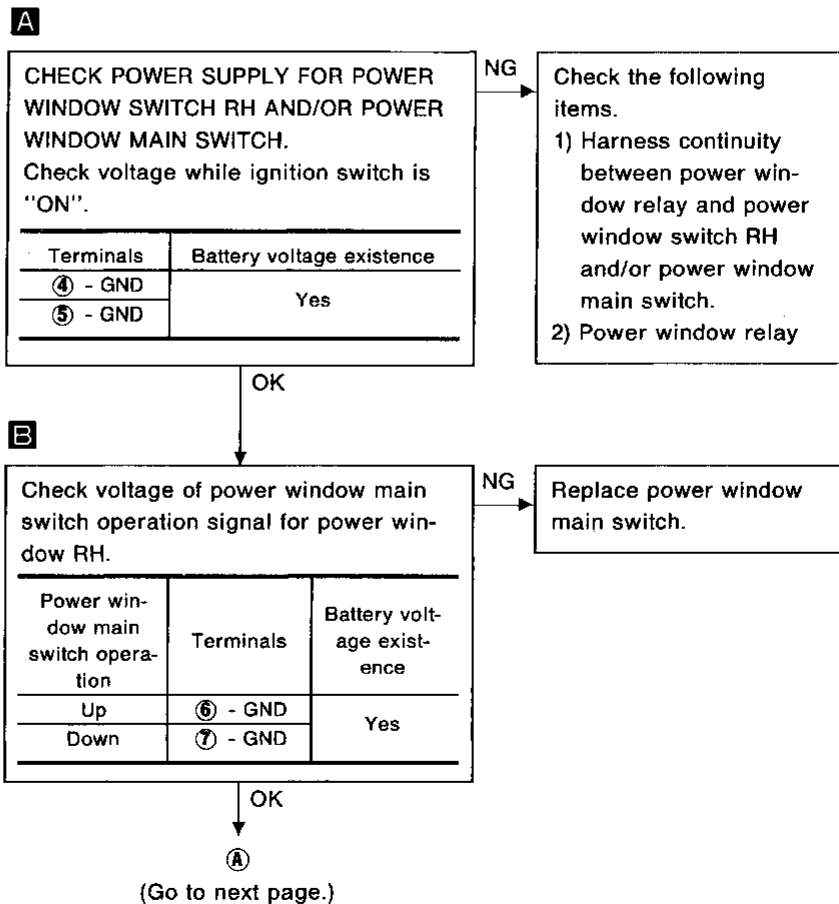
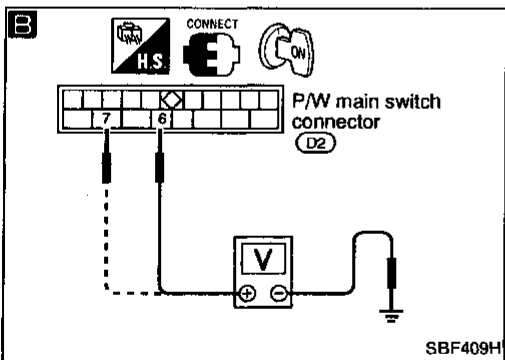

POWER WINDOW

Trouble Diagnosis (Cont'd)

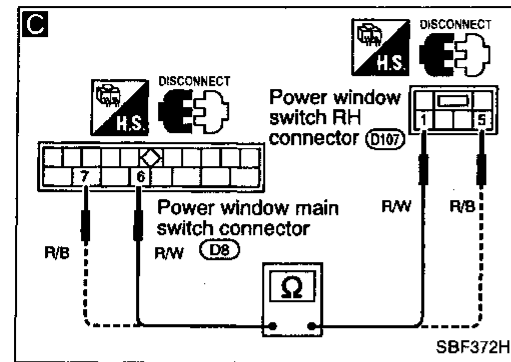

C

↓

C

CHECK POWER WINDOW SWITCH RH AND POWER WINDOW MAIN SWITCH CIRCUIT. Check continuity.

Terminals
① - ⑥
⑤ - ⑦

Does continuity exist?

No → Repair harness.

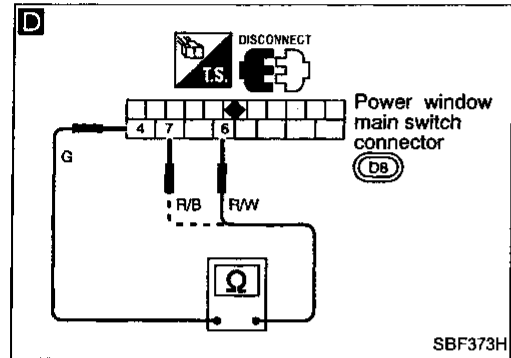

D

Yes

D

CHECK POWER WINDOW MAIN SWITCH. Check continuity when power window lock switch is OFF and power window main switch is in neutral position.

Terminals
⑥ - ④
⑦ - ④

Does continuity exist?

No → Replace power window main switch.

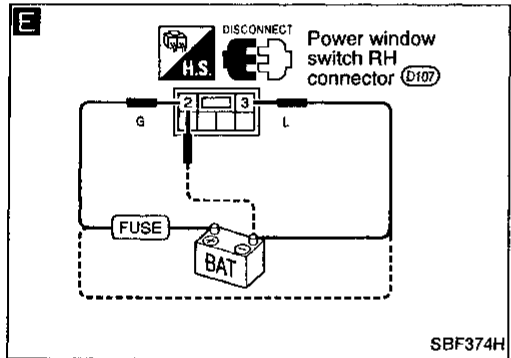

E

Yes

E

CHECK POWER WINDOW MOTOR RH CIRCUIT. Check power window operation.

Terminals	Window	
⊕	⊖	Window
②	③	Up
③	②	Down

OK → Replace power window switch RH.

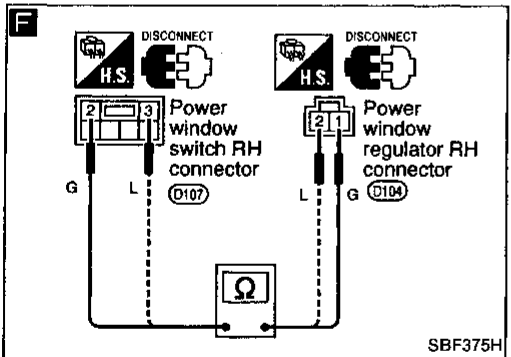

NG

F

1) Disconnect connector from power window regulator RH.
2) Check continuity.

Terminals
② - ①
③ - ②

Does continuity exist?

No → Repair harness.

Yes

Go to Power Window Motor RH in Electrical Component Inspection. (See page BF-26.)

NG → Replace power window motor RH.

OK → Check system again.

Note:
If passenger power window does not lock using lock button of main switch, replace power window main switch. (Passenger power window can be operated.)

POWER WINDOW

Trouble Diagnosis (Cont'd)

ELECTRICAL COMPONENTS INSPECTION

POWER WINDOW MOTOR

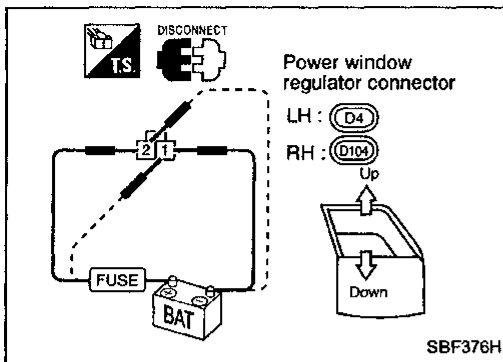

Terminals		Operation
⊕	⊖	
①	②	Upward
②	①	Downward

POWER DOOR LOCK

System Description

Power is supplied at all times

- through 25A fusible link (No. 11 located in the fuse and fusible link box)
- to circuit breaker terminal ①
- through circuit breaker terminal ②
- to smart entrance control unit terminal ①.

Ground is supplied to smart entrance control unit terminal ⑩ through body ground (M5).

INPUT

When the door lock & unlock switch LH is in LOCKED position, ground signal is supplied

- to smart entrance control unit terminal ⑩
- through door lock & unlock switch LH terminal ⑫
- to door lock & unlock switch LH terminal ④
- through body ground (M5).

When the door lock & unlock switch RH is in LOCKED position, ground signal is supplied

- to smart entrance control unit terminal ⑩
- through door lock & unlock switch RH terminal ③
- to door lock & unlock switch RH terminal ②
- through body ground (M57).

When the door lock & unlock switch LH is in UNLOCKED position, ground signal is supplied

- to smart entrance control unit terminal ⑩
- through door lock & unlock switch LH terminal ⑬
- to door lock & unlock switch LH terminal ④
- through body ground (M5).

When the door lock & unlock switch RH is in UNLOCKED position, ground signal is supplied

- to smart entrance control unit terminal ⑩
- through door lock & unlock switch RH terminal ①
- to door lock & unlock switch RH terminal ②
- through body ground (M57).

OUTPUT

Unlock

Ground is supplied

- to door lock actuator LH terminal ③
- to door lock actuator RH terminal ③
- through smart entrance control unit terminal ④.

DOOR LH

Power is supplied

- to door lock actuator LH terminal ①
- through smart entrance control unit terminal ③.

DOOR RH

Power is supplied

- to door lock actuator RH terminal ①,
- through smart entrance control unit terminal ②.

Then, the door is unlocked.

Lock

Ground is supplied

- to door lock actuator LH terminal ①
- through smart entrance control unit terminal ③, and
- to door lock actuator RH terminal ①
- through smart entrance control unit terminal ②.

Power is supplied

- to door lock actuator LH terminal ③,
- to door lock actuator RH terminal ③,
- through terminal ④.

Then, the door is locked.

GI

MA

EM

LC

EC

FE

CL

MT

AT

PD

FA

RA

BR

ST

BF

HA

EL

IDX

POWER DOOR LOCK

Wiring Diagram — D/LOCK —

BF-D/LOCK-01

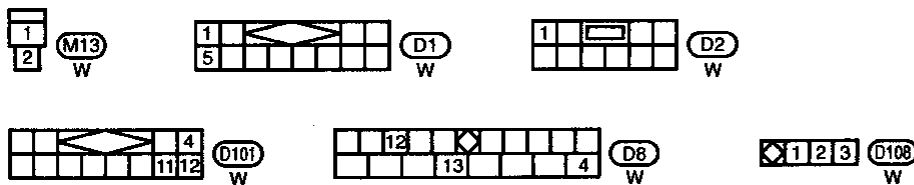
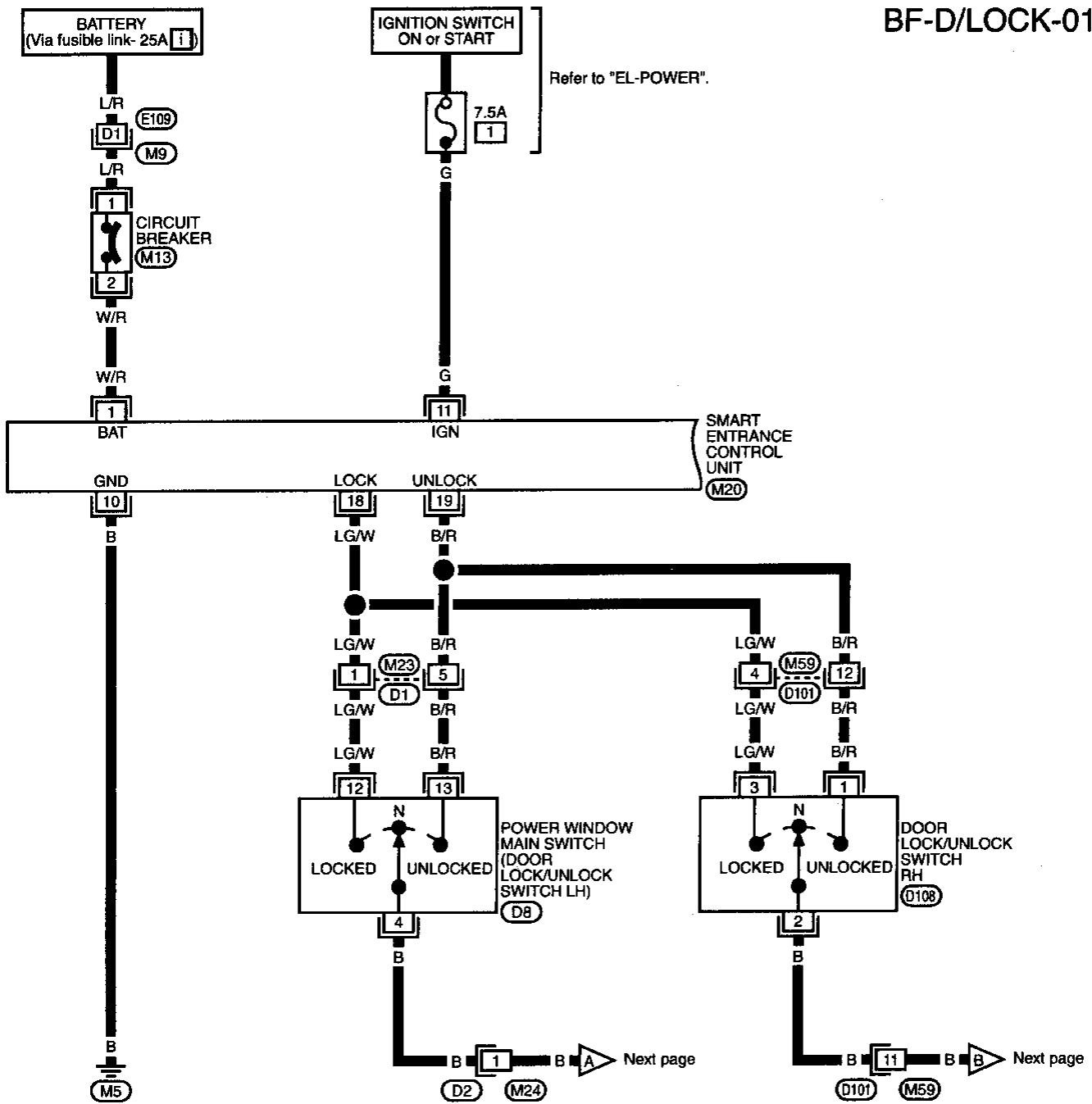

Refer to last page (Foldout page).

M9, E109
M20

POWER DOOR LOCK

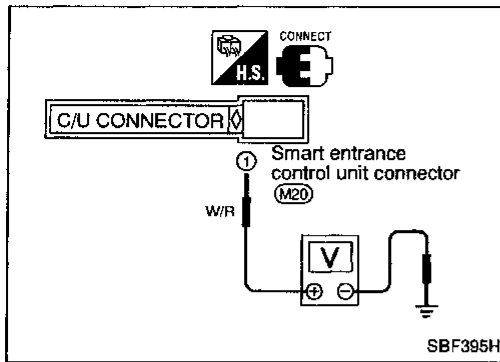

Trouble Diagnosis

MAIN POWER SUPPLY AND GROUND CIRCUIT CHECK

Main power supply for smart entrance control unit (SECU)

Terminals	Battery voltage existence
① - Ground (GND)	Yes

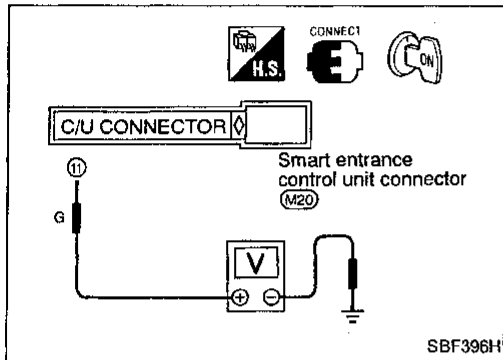

Main power supply while ignition switch is "ON" or "START" position

Terminals	Battery voltage existence
⑪ - Ground	Yes

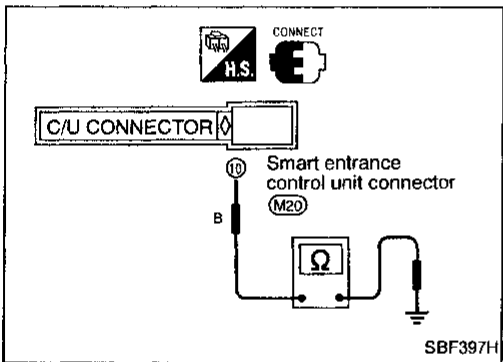

Ground circuit for smart entrance control unit

Terminals	Continuity
⑩ - Ground	Yes

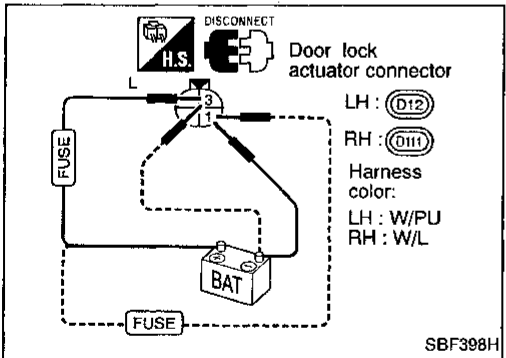

ELECTRICAL COMPONENTS INSPECTION

Power door lock motor

Door lock condition	Terminals	
	⊕	⊖
Unlocked → Locked	③	①
Locked → Unlocked	①	③

POWER DOOR LOCK

Trouble Diagnosis (Cont'd)

DIAGNOSTIC PROCEDURE 1

SYMPTOM: Driver's and/or Passenger's power door lock cannot be operated by door lock/unlock switch LH and/or RH.

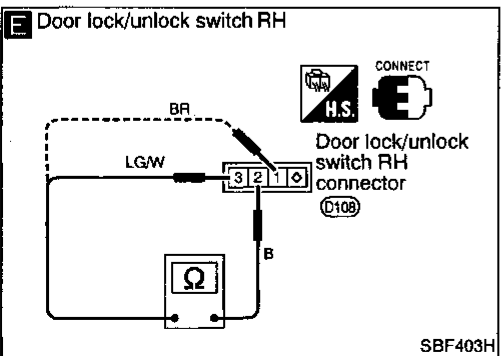
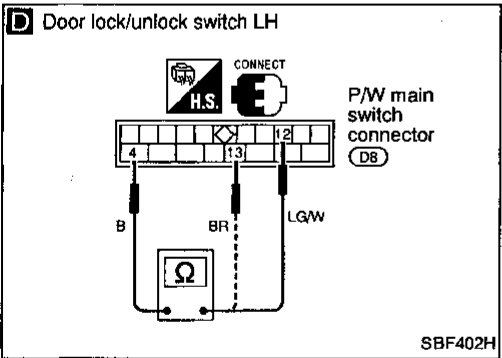
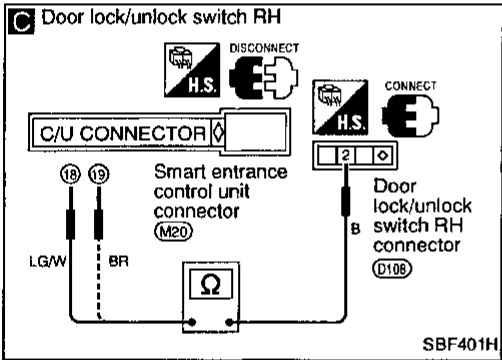
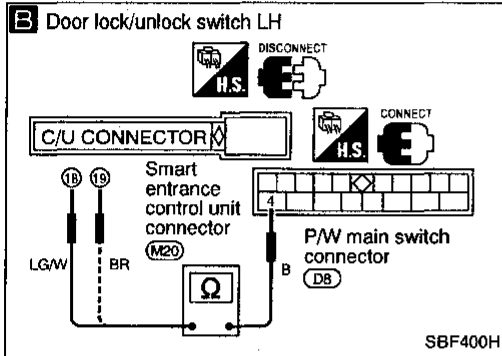
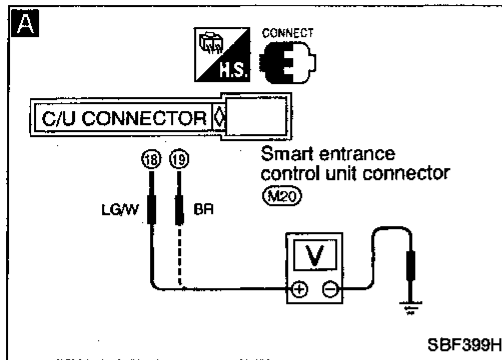

A

CHECK SIGNAL OF DOOR LOCK/UNLOCK SWITCH.

Door lock/unlock switch (LH or RH) operation	Terminals	Voltage (V)
Lock	⑱ - GND	12 → 0 → 12
Unlock	⑲ - GND	12 → 0 → 12

OK → **A** (Go to next page.)

B C

CHECK CIRCUIT BETWEEN CONTROL UNIT AND DOOR LOCK/UNLOCK SWITCH.

- 1) Disconnect control unit connector.
- 2) Check continuity.

B Door lock/unlock switch LH

Operation	Terminals	Continuity
Lock	⑱ - ④	Yes
Unlock	⑲ - ④	

C Door lock/unlock switch RH

Operation	Terminals	Continuity
Lock	⑱ - ②	Yes
Unlock	⑲ - ②	

OK → Repair ground harness of door lock/unlock switch.

D E

Check continuity.

D Door lock/unlock switch LH

Operation	Terminals	Continuity
Lock	⑫ - ④	Yes
Unlock	⑬ - ④	

E Door lock/unlock switch RH

Operation	Terminals	Continuity
Lock	③ - ②	Yes
Unlock	① - ②	

OK → Repair harness between door lock/unlock switch and control unit connector.

NG

Replace door lock/unlock switch.

GI
MA
EM
LC
EC
FE
CL
MT
AT
PD
FA
RA
BR
ST
BF
HA
EL
IDX

POWER DOOR LOCK

Trouble Diagnosis (Cont'd)

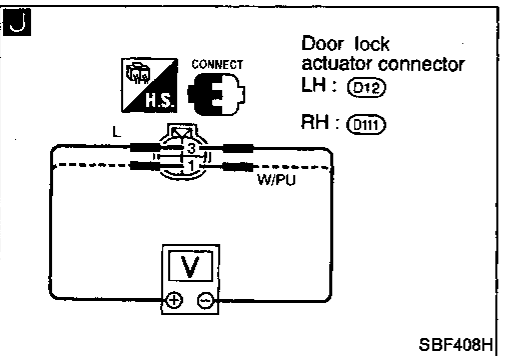
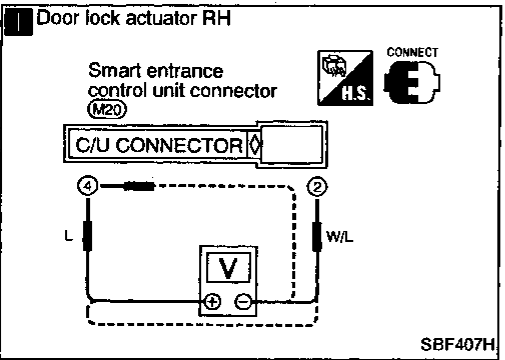
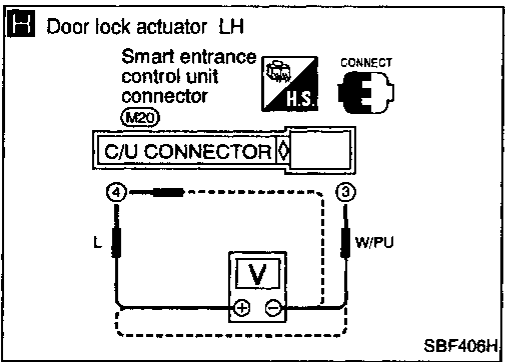
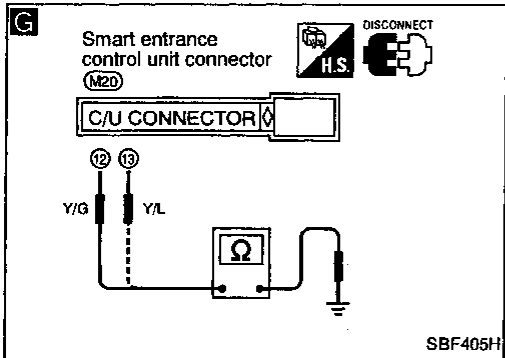
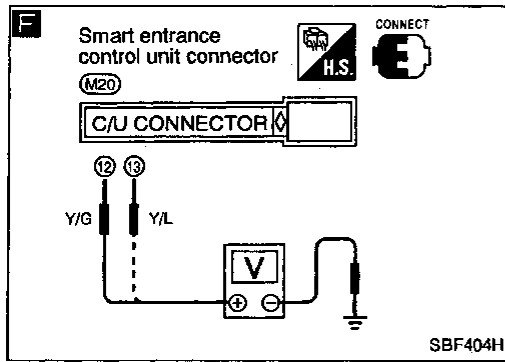

F CHECK DOOR UNLOCK SIGNAL.

Door lock knob condition	Terminals	Voltage (V)
Lock →	LH ⑫ - GND	12 → 0 →
Unlock →	RH ⑬ - GND	12

G

1) Disconnect control unit connector.
2) Check continuity.

Lock knob condition	Terminals	Continuity
Unlock	⑫ - GND ⑬ - GND	Yes

OK

H I

H I CHECK DOOR LOCK ACTUATOR CIRCUIT.
Check voltage for door lock motor.

H Door lock actuator LH

Door lock/ unlock switch operation	Terminals	Voltage (V)
Lock	⊕ ④ ⊖ ③	Battery voltage
Unlock	③ ④	

I Door lock actuator RH

Door lock/ unlock switch operation	Terminals	Voltage (V)
Lock	⊕ ④ ⊖ ②	Battery voltage
Unlock	② ④	

OK

J

J Check voltage for door lock motor.

Door lock/ unlock switch operation	Terminals	Voltage (V)
Lock	⊕ ③ ⊖ ①	Battery voltage
Unlock	① ③	

OK

Go to power door lock motor in ELECTRICAL COMPONENTS INSPECTION. (See page BF-30.)

OK

Check system again.

NG

Replace smart entrance control unit.

NG

Repair door unlock signal harness or replace door lock actuator.

NG

Replace smart entrance control unit.

NG

Repair harness between control unit connector and door lock actuator.

NG

Replace power door lock motor LH and/or RH.

System Description

Power is supplied at all times

- to smart entrance control unit terminal ①
- through 25A fuse (letter **I** located in the fusible link and fuse box).

Power is supplied at all times

- to interior lamp terminal ① and
- to key switch terminal ①
- through 10A fuse (No. **6** located in the fuse block).

Power is supplied at all times

- to multi-remote control relay-1 terminal ①
- through 10A fuse (No. **5** located in the fuse block).

Terminal ⑩ of the smart entrance control unit is grounded through body ground **(M5)**.

INPUTS

When the key switch is ON (ignition key is inserted in key cylinder), power is supplied

- through key switch terminal ②
- to smart entrance control unit terminal ⑭.

When the door switch LH is OPEN, ground is supplied

- to smart entrance control unit terminal ⑮
- through door switch LH terminal ①
- to door switch LH terminal ③
- through body ground **(B4)**.

When the door switch RH is OPEN, ground is supplied

- to smart entrance control unit terminal ⑯
- through door switch RH body ground.

When the door lock actuator LH (door unlock sensor) is UNLOCKED, ground is supplied

- to smart entrance control unit terminal ⑫
- through door lock actuator LH (door unlock sensor) terminal ④
- to door lock actuator LH (door unlock sensor) terminal ②
- through body ground **(M5)**.

When the door lock actuator RH (door unlock sensor) is UNLOCKED, ground is supplied

- to smart entrance control unit terminal ⑬
- through door lock actuator RH (door unlock sensor) terminal ④
- to door lock actuator RH (door unlock sensor) terminal ②
- through body ground **(M57)**.

Remote controller signal input

- through window antenna
- to smart entrance control unit terminal ⑰.

The multi-remote control system controls operation of the

- power door lock
- interior lamp
- panic alarm
- hazard lamp
- ID code entry.

OPERATED PROCEDURE

Power door lock operation

When the following input signals are both supplied:

- key switch OFF (when ignition key is not inserted in key cylinder);
- door switch CLOSED (when all the doors are closed);

smart entrance control unit locks all the doors with input of LOCK signal from remote controller.

When key switch is OFF (when ignition key is not inserted in key cylinder), smart entrance control unit unlocks the doors with input of UNLOCK signal from remote controller.

Refer to "Power Door Lock" in BF section and "THEFT WARNING SYSTEM" in EL section.

GI

MA

EM

LC

EC

FE

CL

MT

AT

PD

FA

RA

BR

ST

BF

HA

EL

IDX

MULTI-REMOTE CONTROL SYSTEM

System Description (Cont'd)

Interior lamp operation

When the following input signals are both supplied:

- key switch OFF (when ignition key is not inserted in key cylinder);
- door switch CLOSED (when all the doors are closed);

multi-remote control system turns on interior lamp (for 30 seconds) with input of UNLOCK signal from remote controller.

For detailed description, refer to "Interior, Spot and Trunk Room Lamps" in EL section.

Panic alarm operation

When key switch is OFF (when ignition key is not inserted in key cylinder), multi-remote control system turns on and off horn and headlamp intermittently with input of PANIC ALARM signal from remote controller.

For detailed description, refer to "THEFT WARNING SYSTEM" in EL section.

Hazard lamp operation

When the following input signals are all supplied:

- key switch OFF (when ignition key is not inserted in key cylinder);
- door switch CLOSED (when all the doors are closed);
- door lock actuator (door unlock sensor) LOCKED (when all the doors are locked);

multi-remote control system outputs the following ground signals with input of LOCK signal from remote controller:

- to multi-remote control relay-1 terminal ②;
- through smart entrance control unit terminal ⑦.

As a result, multi-remote control relay-1 is energized, and hazard warning lamps flash on and off.

For detailed description, refer to "Turn Signal and Hazard Warning Lamps" in EL section.

MULTI-REMOTE CONTROL SYSTEM

Wiring Diagram — MULTI —

BF-MULTI-01

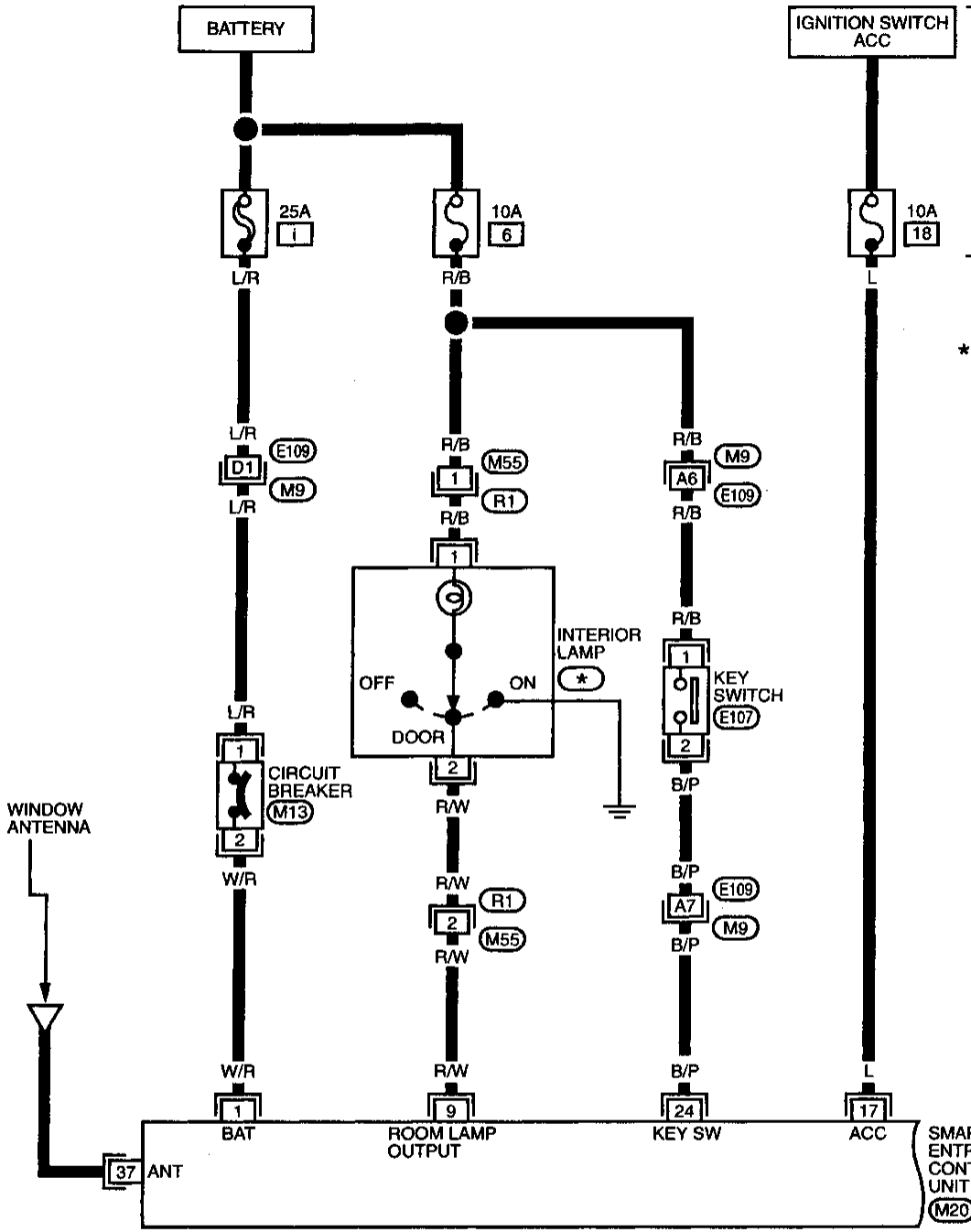

Refer to "EL-POWER".

- * : (R4) Without sun roof
- (R5) With sun roof

GI
MA
EM
LC
EC
FE
CL
MT
AT
PD
FA
RA
BR
ST
BF
HA
EL
IDX

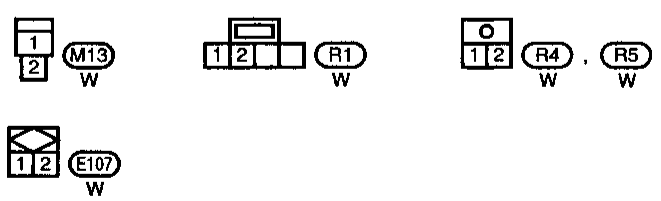

Refer to last page (Foldout page).

- (M9), (E109)
- (M20)

MULTI-REMOTE CONTROL SYSTEM

Wiring Diagram — MULTI — (Cont'd)

BF-MULTI-02

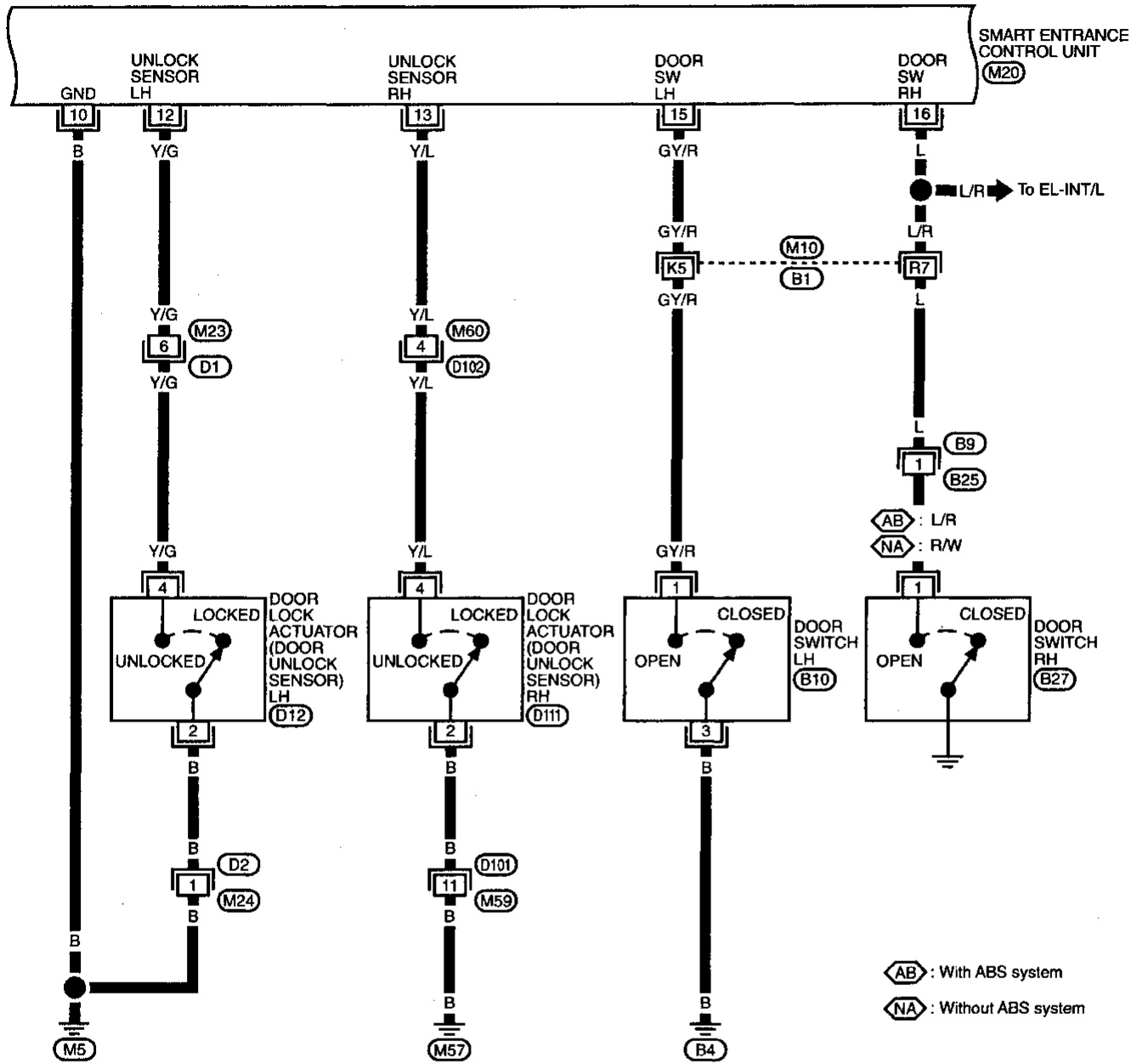

Refer to last page (Foldout page).

(M10) (B1)
 (M20)

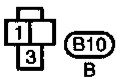
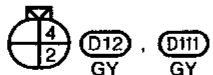
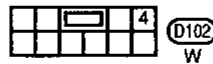

MULTI-REMOTE CONTROL SYSTEM

Wiring Diagram — MULTI — (Cont'd)

BF-MULTI-03

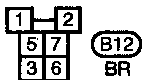
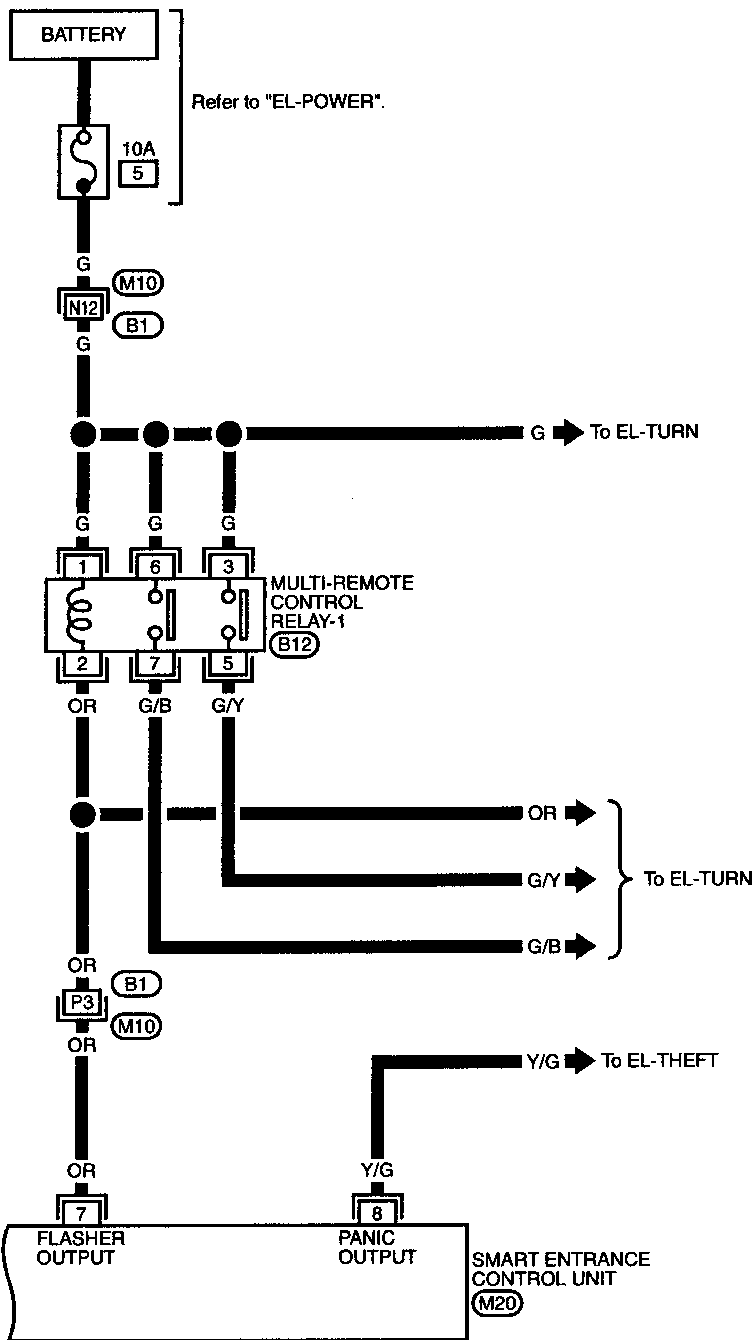

Refer to last page (Foldout page).

(M10) , (B1)

(M20)

GI

MA

EM

LC

EC

FE

CL

MT

AT

PD

FA

RA

BR

ST

BF

HA

EL

IDX

MULTI-REMOTE CONTROL SYSTEM

Schematic

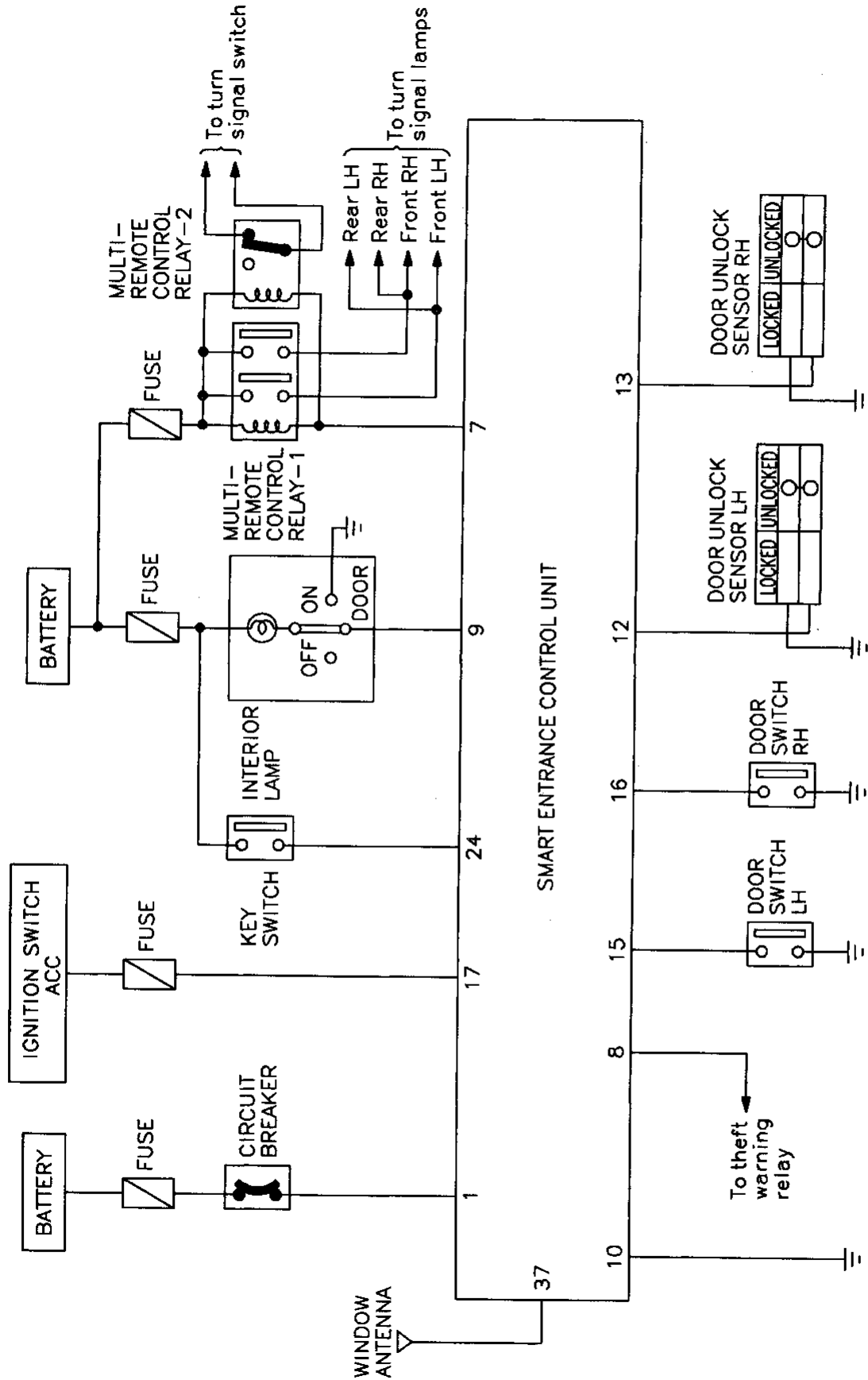

MULTI-REMOTE CONTROL SYSTEM

Input/Output Operation Signal

SMART ENTRANCE CONTROL UNIT

Terminal No.	Connections	Operated condition	Voltage (V) (Approximate values)		
1	Power source (C/B)	—	12V	GI	
2	Passenger door lock motor	Door lock & unlock switch	Unlocked	12V	MA
3	Driver door lock motor		Free	0V	EM
4	Driver and passenger door lock motors	Door lock & unlock switch	Locked	12V	LC
			Free	0V	
7	Multi-remote control relay 1	When doors are locked using remote controller	12V → 0V	EC	
8	Theft warning relay	When panic alarm is operated using remote controller	12V → 0V	FE	
9	Interior lamp	When interior lamp is operated using remote controller. (Lamp switch in "DOOR" position)	12V → 0V	CL	
10	Ground	—	—		
11	Ignition switch (ON)	"ON" position	12V	CL	
12	Driver door unlock sensor	Driver door: Locked → Unlocked	12V → 0V	MT	
13	Passenger door unlock sensor	Passenger door: Locked → Unlocked	12V → 0V	AT	
15	Driver door switch	OFF (Closed) → ON (Open)	12V → 0V	PD	
16	Passenger door switch	OFF (Closed) → ON (Open)	12V → 0V	FA	
17	Ignition switch (ACC)	"ACC" position	12V	RA	
18	Door lock & unlock switches	Neutral → Locks	12V → 0V	BR	
19	Door lock & unlock switches	Neutral → Unlocks	12V → 0V	ST	
20	Rear window defogger switch	OFF → ON	12V → 0V	BF	
21	Seat belt switch	Unfasten → Fasten	0V → 12V	HA	
23	Warning buzzer	OFF → ON	12V → 0V	EL	
24	Ignition key switch (Insert)	IGN key inserted → IGN key removed from IGN key cylinder	12V → 0V	IDX	
25	Headlamp switch (1ST)	1ST, 2ND positions: ON → OFF	12V → 0V		
26	Trunk switch	ON (Open) → OFF (Closed)	0V → 12V		
27	Trunk key unlock switch	OFF (Neutral) → ON (Unlocked)	5V → 0V		
28	Door key cylinders tamper switch	OFF → ON	5V → 0V		
29	Hood open signal	ON (Open) → OFF (Closed)	0V → 5V		
30	Door key cylinder lock switch	OFF (Neutral) → ON (Locked)	5V → 0V		
31	Door key cylinder lock switch	OFF (Neutral) → ON (Unlocked)	5V → 0V		
32	Theft warning relay (Starter cut)	OFF → ON	12V → 0V		
33	Theft warning indicator	Goes off → Illuminates	12V → 0V		
36	Rear defogger relay	OFF → ON	12V → 0V		
37	Multi-remote antenna	—	—		

MULTI-REMOTE CONTROL SYSTEM

Trouble Diagnoses

TROUBLE SYMPTOM

- All functions of remote control system do not operate.

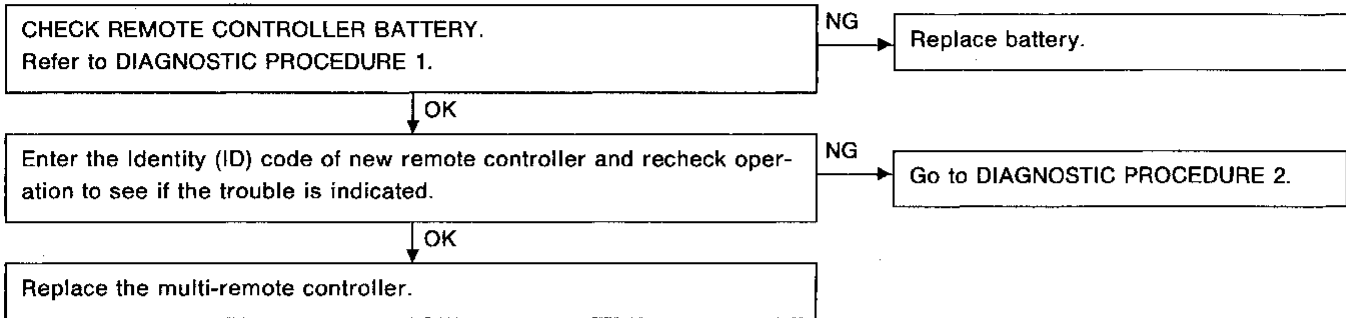

- Some functions of multi-remote controller do not operate.

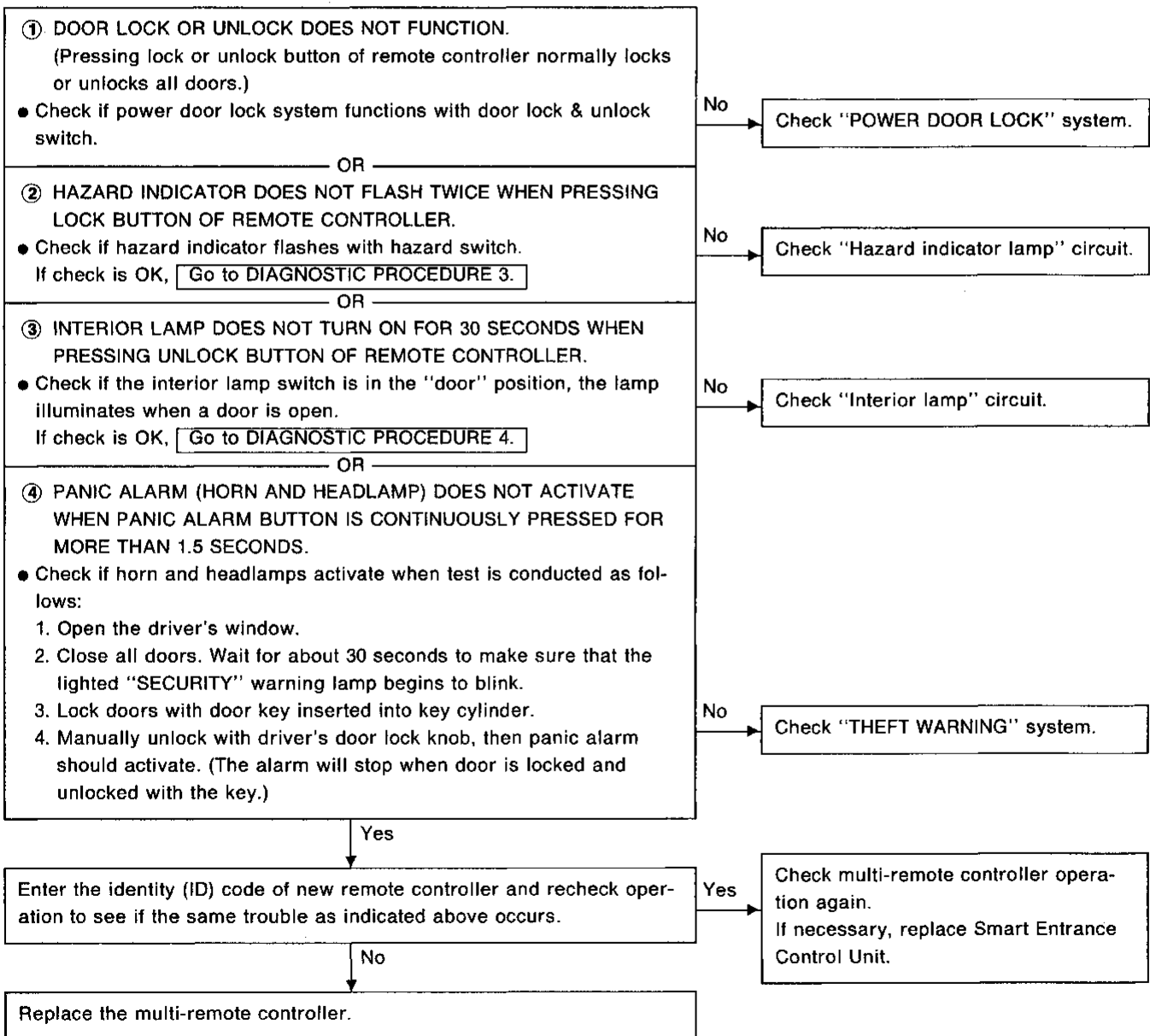

Note: The multi-remote control system does not activate with the ignition key inserted in the ignition key cylinder.

MULTI-REMOTE CONTROL SYSTEM

Trouble Diagnoses (Cont'd)

DIAGNOSTIC PROCEDURE 1

Check remote controller battery.

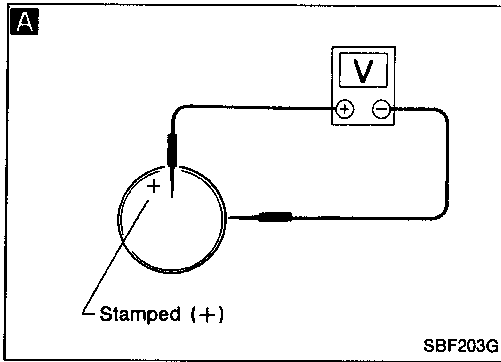

A

CHECK REMOTE CONTROLLER BATTERY.

Remove battery and measure voltage across battery positive and negative terminals ⊕ and ⊖.

Measuring terminal		Standard value
⊕	⊖	
Battery positive terminal ⊕	Battery negative terminal ⊖	3V or more

Note:

Remote controller does not function if battery is not set correctly.

GI

MA

EM

LC

EC

FE

CL

MT

AT

PD

FA

RA

BR

ST

BF

HA

EL

IDX

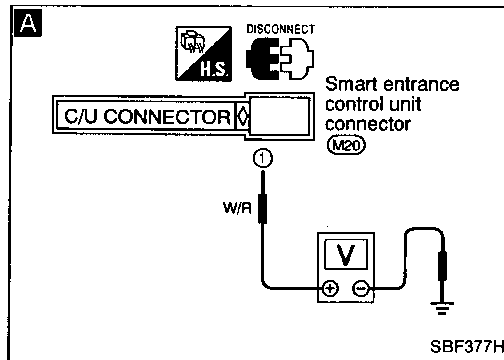

DIAGNOSTIC PROCEDURE 2

All remote controls do not function even if remote controller is operated properly.

A

CHECK MAIN POWER SUPPLY AND GROUND CIRCUIT.

- 1) Remove key from ignition.
- 2) Disconnect connector from control unit. Check voltage across control unit terminal ① and GND.

Battery voltage should exist.

NG → Check power supply harness.

OK

B

Check continuity between terminal ⑩ and GND.

Continuity should exist.

NG → Check GND harness.

OK

C

CHECK ANTENNA CIRCUIT.

Disconnect 1-pin connector from control unit.

Check continuity between a terminal and filament on the rear window.

Continuity should exist.

NG → Check antenna circuit. (Refer to REAR WINDOW DEFOGGER "Filament Repair".)

OK

Ⓐ
(Go to next page.)

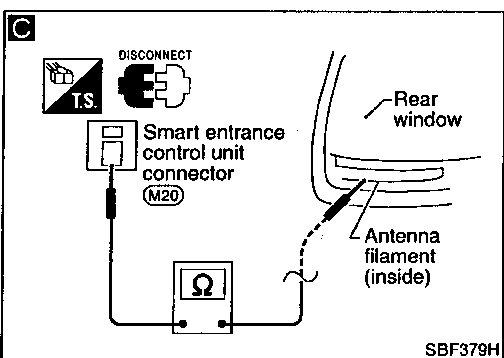
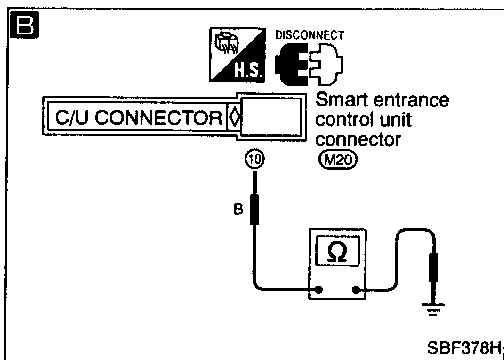

MULTI-REMOTE CONTROL SYSTEM

Trouble Diagnoses (Cont'd)

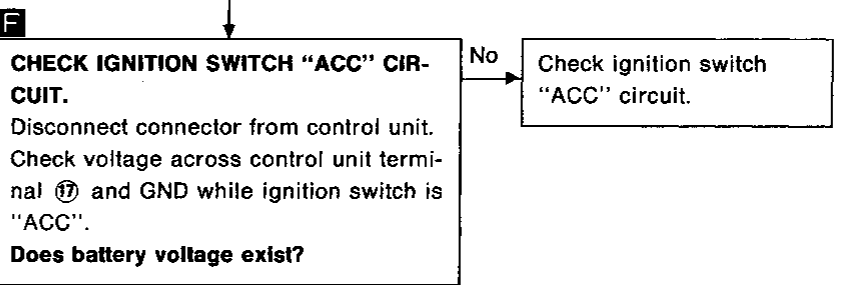
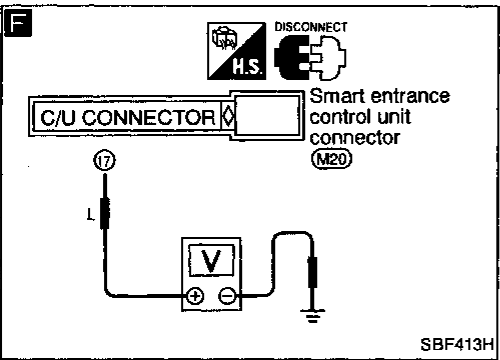
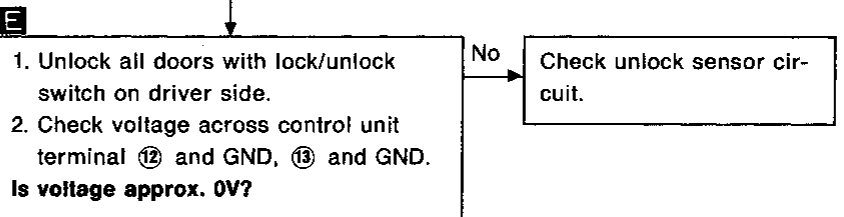
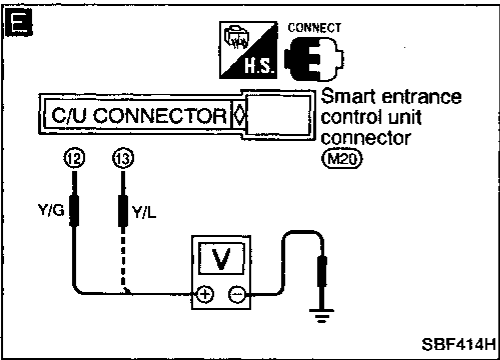
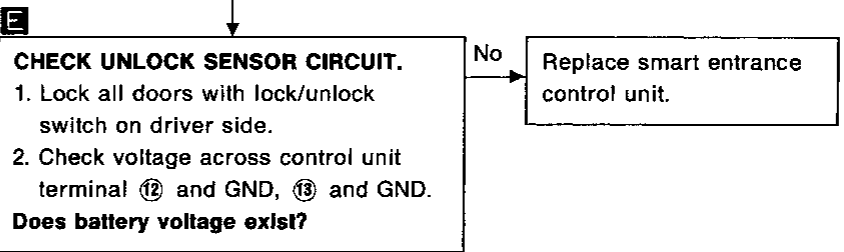
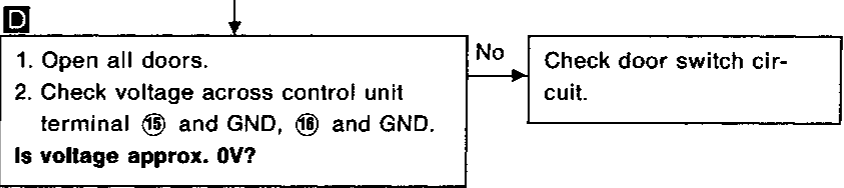
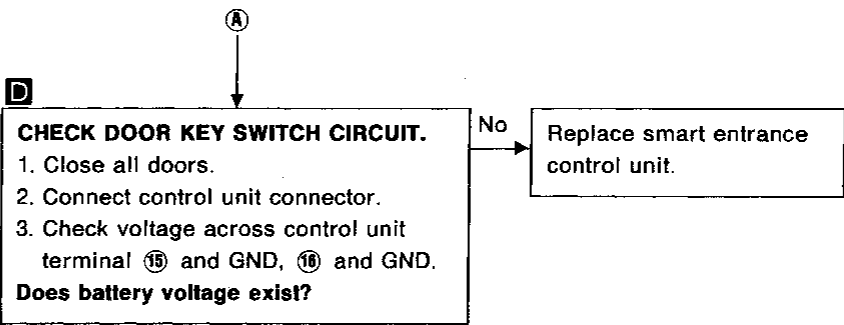
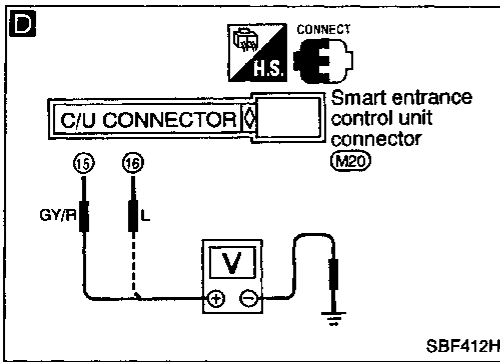

Check operation parts in multi-remote control system for function.

MULTI-REMOTE CONTROL SYSTEM

Trouble Diagnoses (Cont'd)

DIAGNOSTIC PROCEDURE 3

Hazard indicator does not flash twice when pressing lock button of remote controller. Everything else functions.

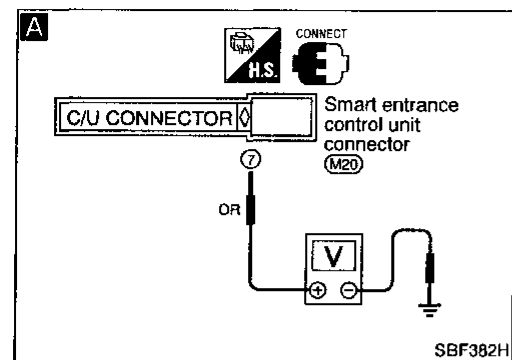

A

CHECK HAZARD INDICATOR FLASHING CIRCUIT.

Check voltage across control unit terminal ⑦ and GND.

Does battery voltage exist?

Yes → **A** (Go to next page.)

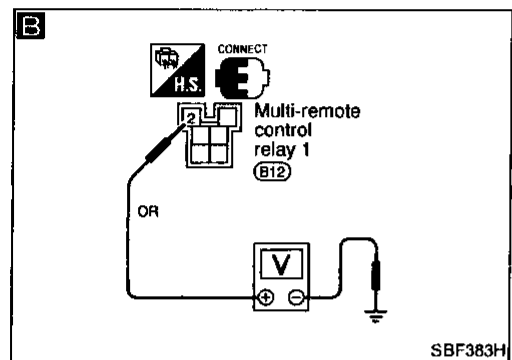

B

Check voltage across multi-remote control relay 1 terminal ② and GND.

Does battery voltage exist?

Yes → **C**

C

1. Disconnect connectors from control unit and multi-remote control relay 1.

2. Check continuity between terminal ⑦ of control unit connector and ② of multi-remote control relay 1.

Does continuity exist?

No → Check system again.

Yes → Repair harness between control unit connector and multi-remote control relay 1 connector.

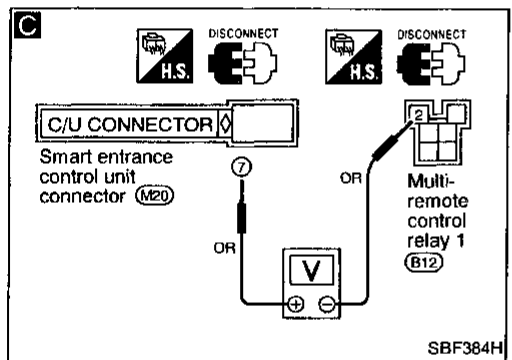

D

Disconnect connector from multi-remote control relay 1.

Check voltage across multi-remote control relay 1 terminal ① and GND.

Does battery voltage exist?

No → Repair power supply harness for multi-remote control relay 1.

Yes → Replace multi-remote control relay 1.

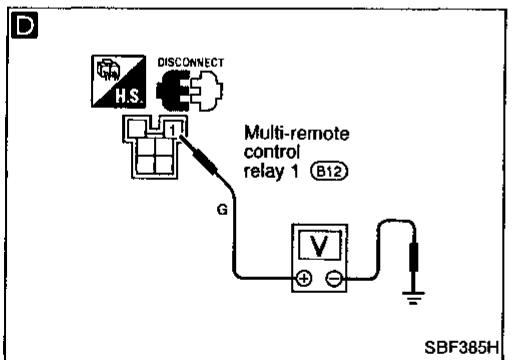

GI
MA
EM
LC
EC
FE
CL
MT
AT
PD
FA
RA
BR
ST
BF
HA
EL
IDX

MULTI-REMOTE CONTROL SYSTEM

Trouble Diagnoses (Cont'd)

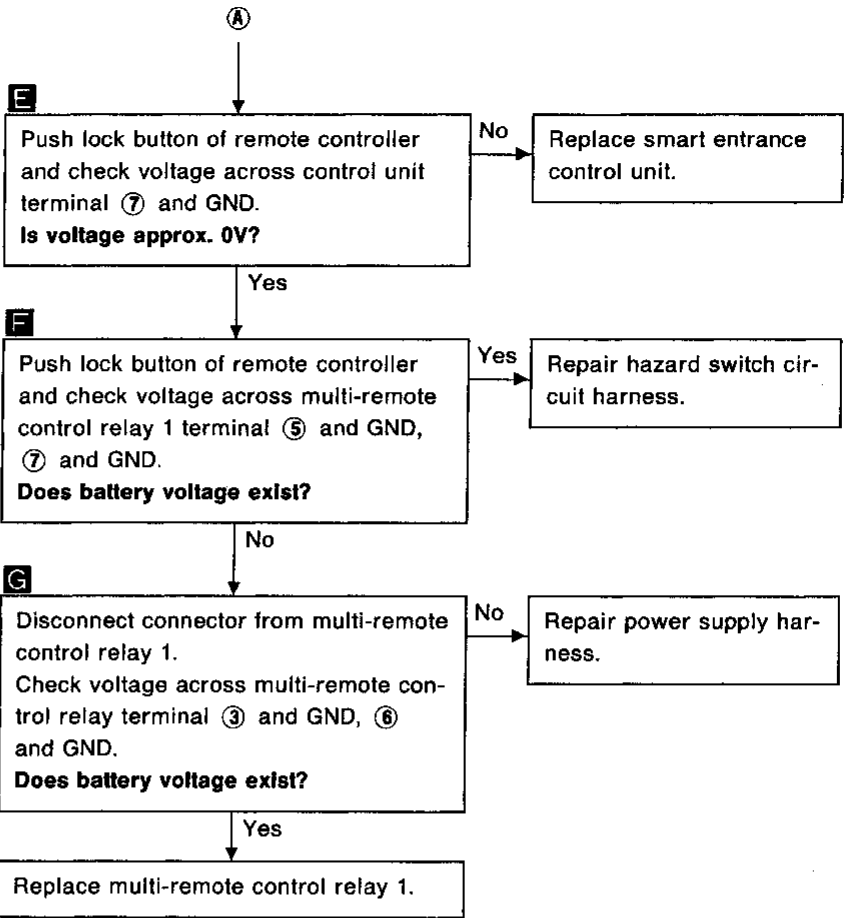
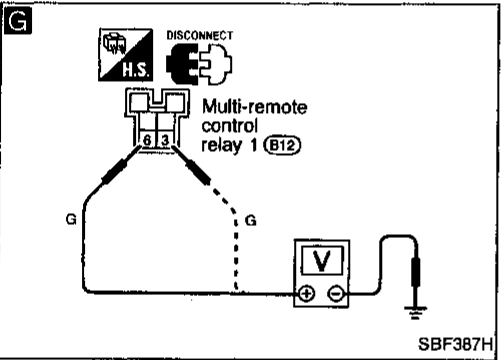
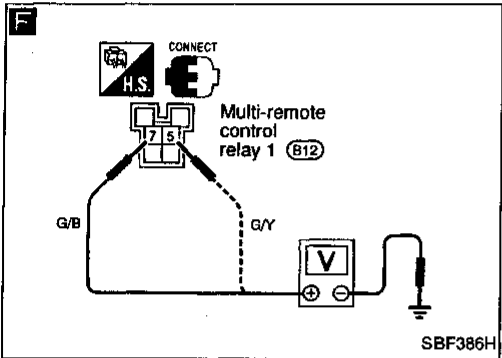
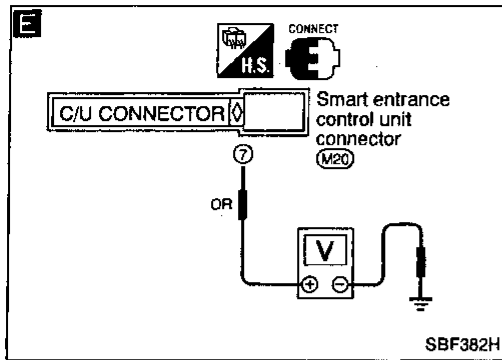

MULTI-REMOTE CONTROL SYSTEM

Trouble Diagnoses (Cont'd)

DIAGNOSTIC PROCEDURE 4

Interior lamp does not turn on for 30 seconds when pressing unlock button of remote controller. Everything else functions.

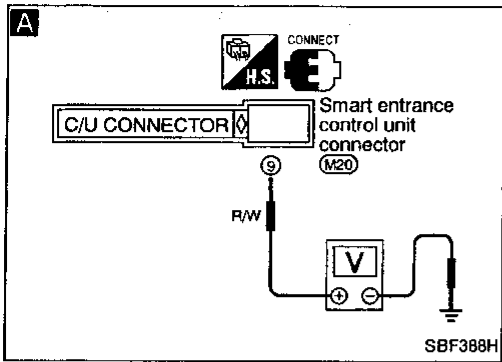

A

CHECK INTERIOR LAMP CIRCUIT.

When interior lamp switch is "DOOR" position, check voltage across control unit terminal ⑨ and GND.

Does battery voltage exist?

No

Repair harness between control unit connector and interior lamp connector.

Yes

A

Push unlock button of remote controller and check voltage across control unit terminal ⑨ and GND.

Is voltage approx. 0V?

No

Replace smart entrance control unit.

Yes

Check system again.

GI

MA

EM

LC

EC

FE

CL

MT

AT

PD

FA

RA

BR

ST

BF

HA

EL

IDX

Replacing Remote Controller or Control Unit

If the remote controller or the control unit needs to be replaced or if an additional remote controller needs to be set, enter the identity (ID) code manually.

ID Code Entry Procedure

To enter the ID code, follow this procedure.

“Setting mode”:

Three steps must be followed to establish the “setting mode”.

- (1) Close and lock all doors.
- (2) Insert and remove the key from the ignition more than six times within 10 seconds. (The hazard warning lamp will then flash twice.)

- **At this time, the original ID codes are eliminated.**

ID code entry:

- (3) Turn ignition key to “ACC” position.
- (4) Push lock button on the new remote controller once (for example, if door is locked using the remote controller during this ID code entry enable state, a new ID code can be entered).

- **At this time, the new ID code is entered. (The hazard warning lamp will then flash twice.)**

- (5) If you need to enter additional remote controllers (including the original), release the driver’s door lock, then lock again with door lock knob.
- (6) Push lock button on the new additional remote controller once.
- (7) This ID code entry enable state and setting mode remain until the driver’s door is opened.

NOTE

- **If the same ID code that existing in the memory is input, the entry is canceled, and no ID code will be entered.**
- **Entry of maximum four ID codes is allowed and any attempt to enter more will be ignored.**
- **Any ID codes entered after termination of the “setting” mode will not be accepted. Additionally remote control signals will be inhibited when an ID code has not been entered during the “setting” mode.**

INSTRUMENT PANEL

CAUTION:

- Disconnect ground terminal from battery in advance.
- Disconnect air bag system line in advance.
- Never tamper with or force air bag lid open, as this may adversely affect air bag performance.
- Be careful not to scratch pad and other parts.

REMOVAL — Instrument panel assembly

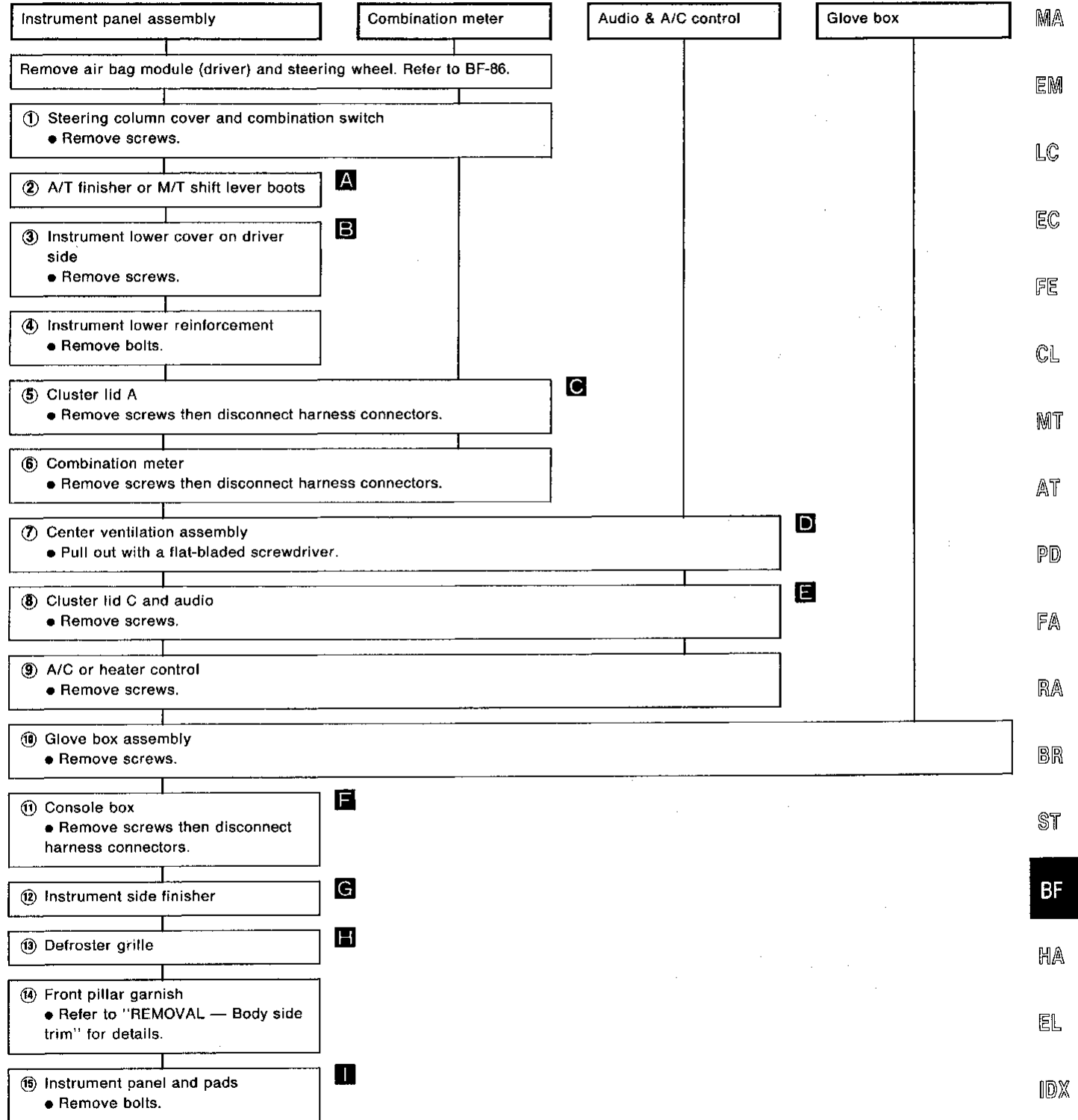

INSTRUMENT PANEL

SEC. 248-487-680-685-969

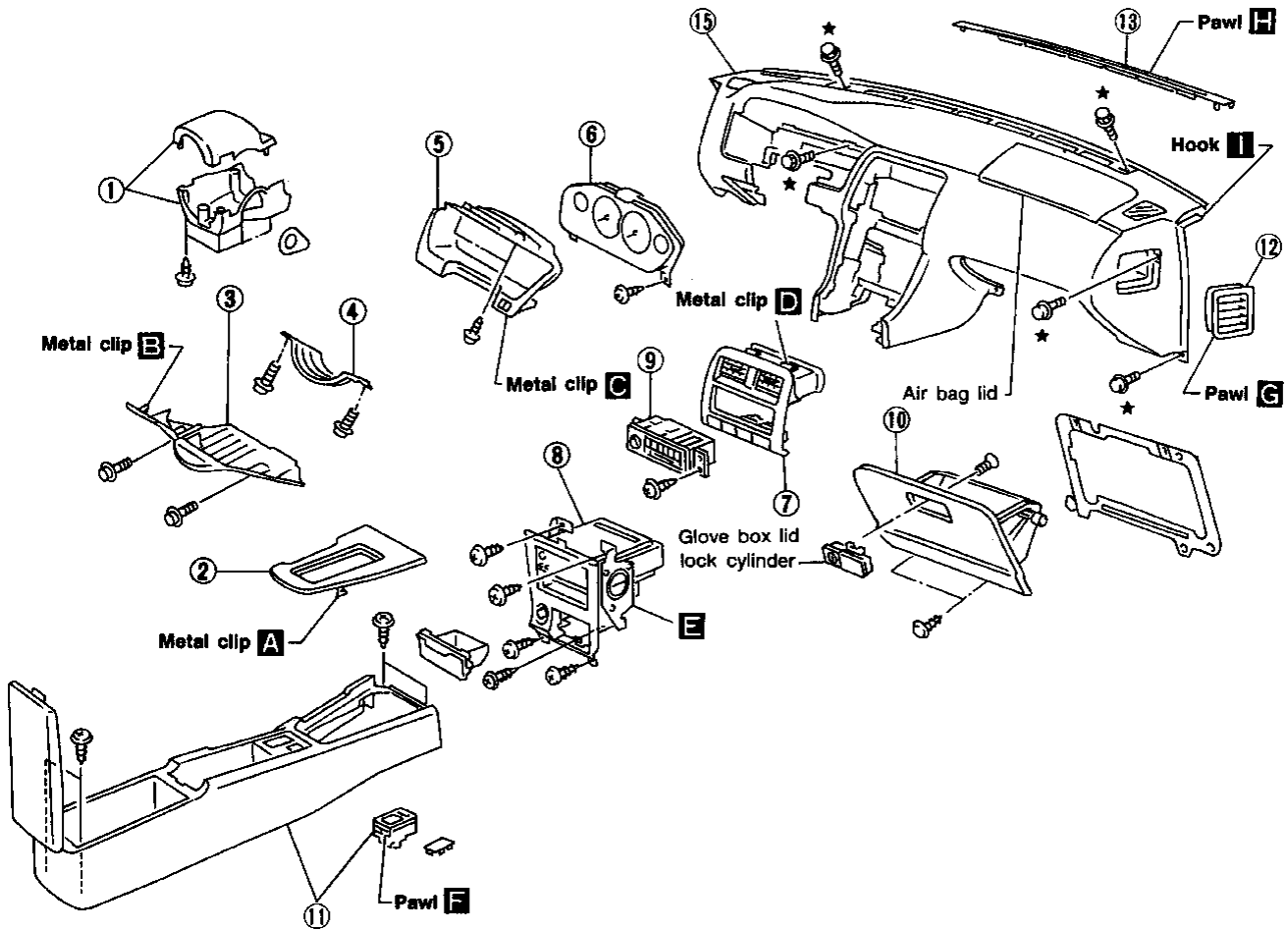

★ : Instrument panel assembly mounting bolts and nuts

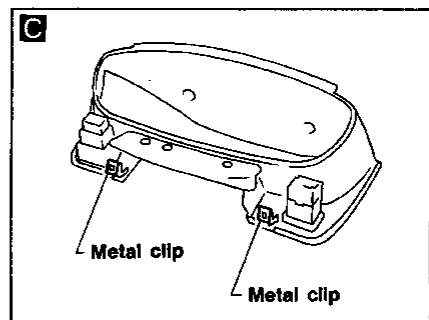
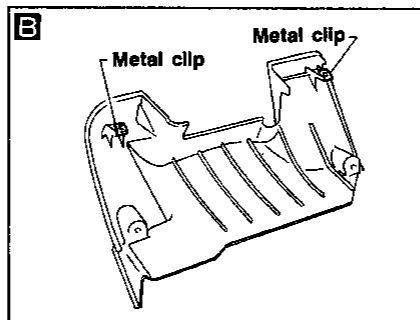
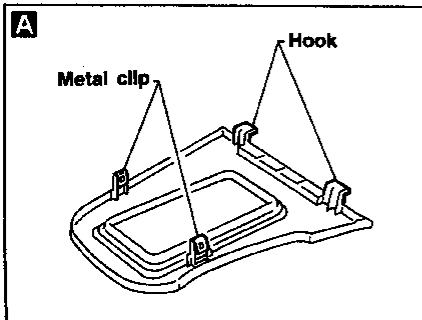

INSTRUMENT PANEL

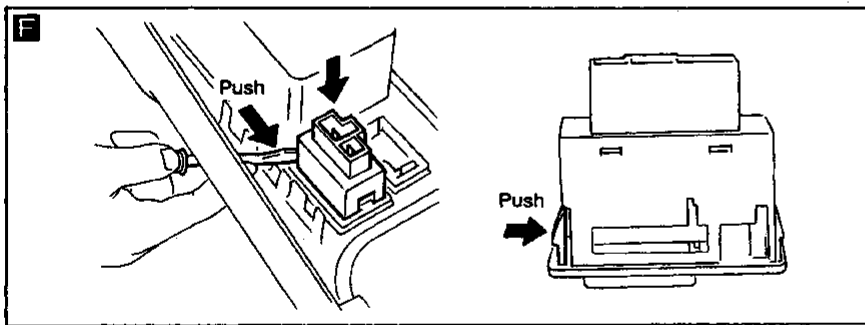
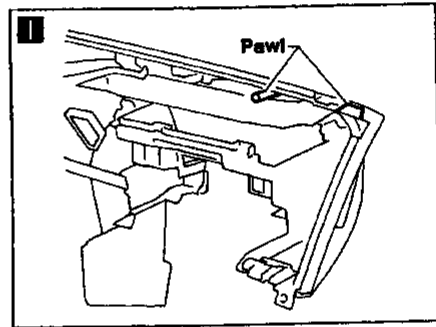
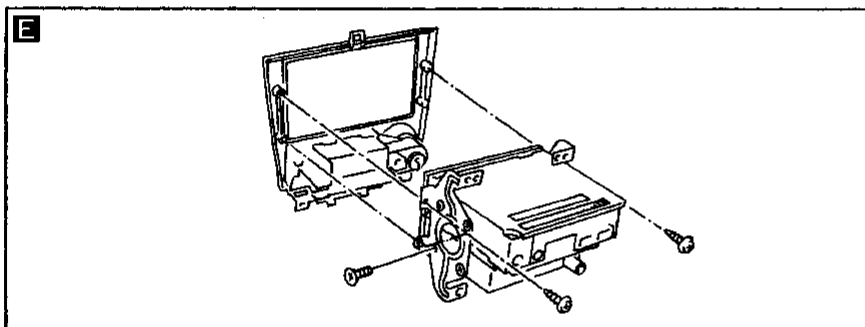
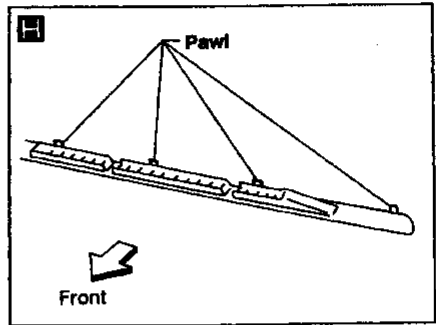
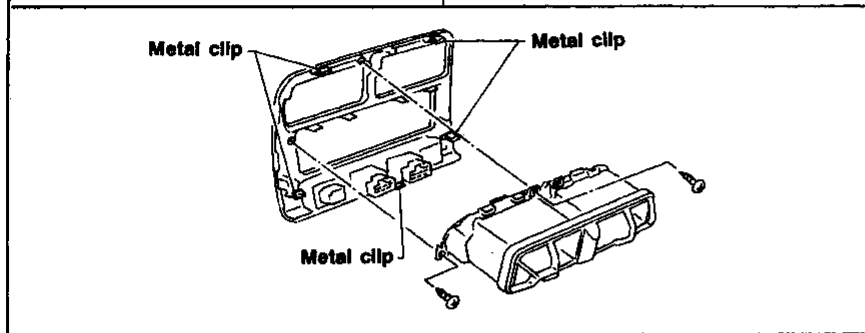
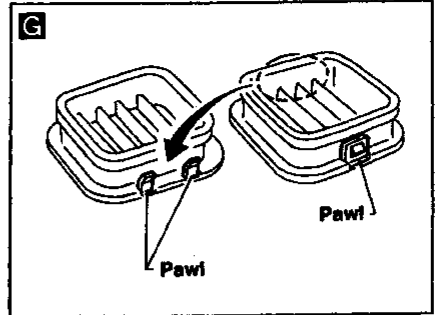
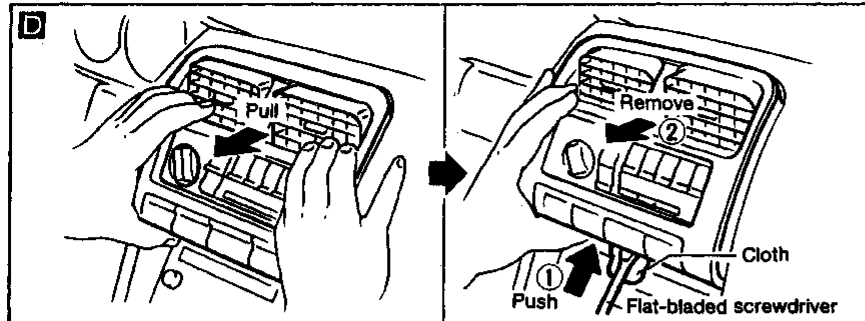

GI
MA
EM
LC
EC
FE
CL
MT
AT
PD
FA
RA
BR
ST
BF
HA
EL
IDX

Interior

SIDE AND FLOOR TRIM

CAUTION:

Wrap the tip of flat-bladed screwdriver with a cloth when removing metal clips from garnishes.

REMOVAL — Body side trim

- ① Remove front and rear seat. Refer to "SEAT" for details (BF-60).
- ② Remove dash side finisher.
- ③ Remove kicking plate.
- ④ Remove front pillar garnish.
- ⑤ Remove rear side finisher.
- ⑥ Remove rear pillar finisher.
- ⑦ Remove rear parcel shelf.
- ⑧ Remove seat back finisher welt. Refer to "LUGGAGE ROOM TRIM" for details.
- ⑨ Remove seat back finishers (Right, Center, Left).

INTERIOR AND EXTERIOR

Interior (Cont'd)

SEC. 678-749-769-799-809

GI
MA
EM
LC
EC
FE
CL
MT
AT
PD
FA
RA
BR
ST
BF
HA
EL
IDX

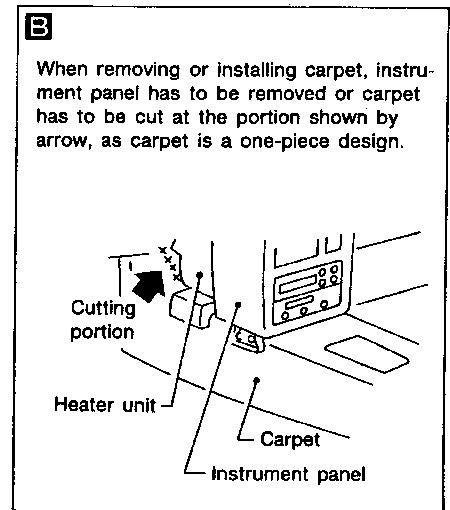
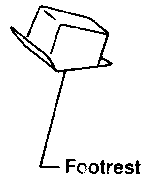
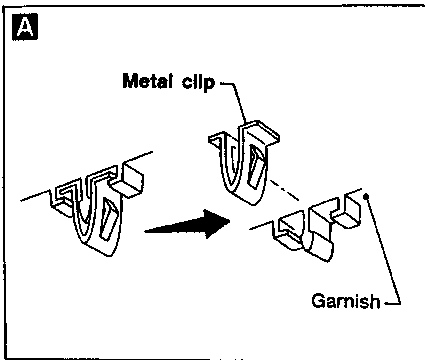
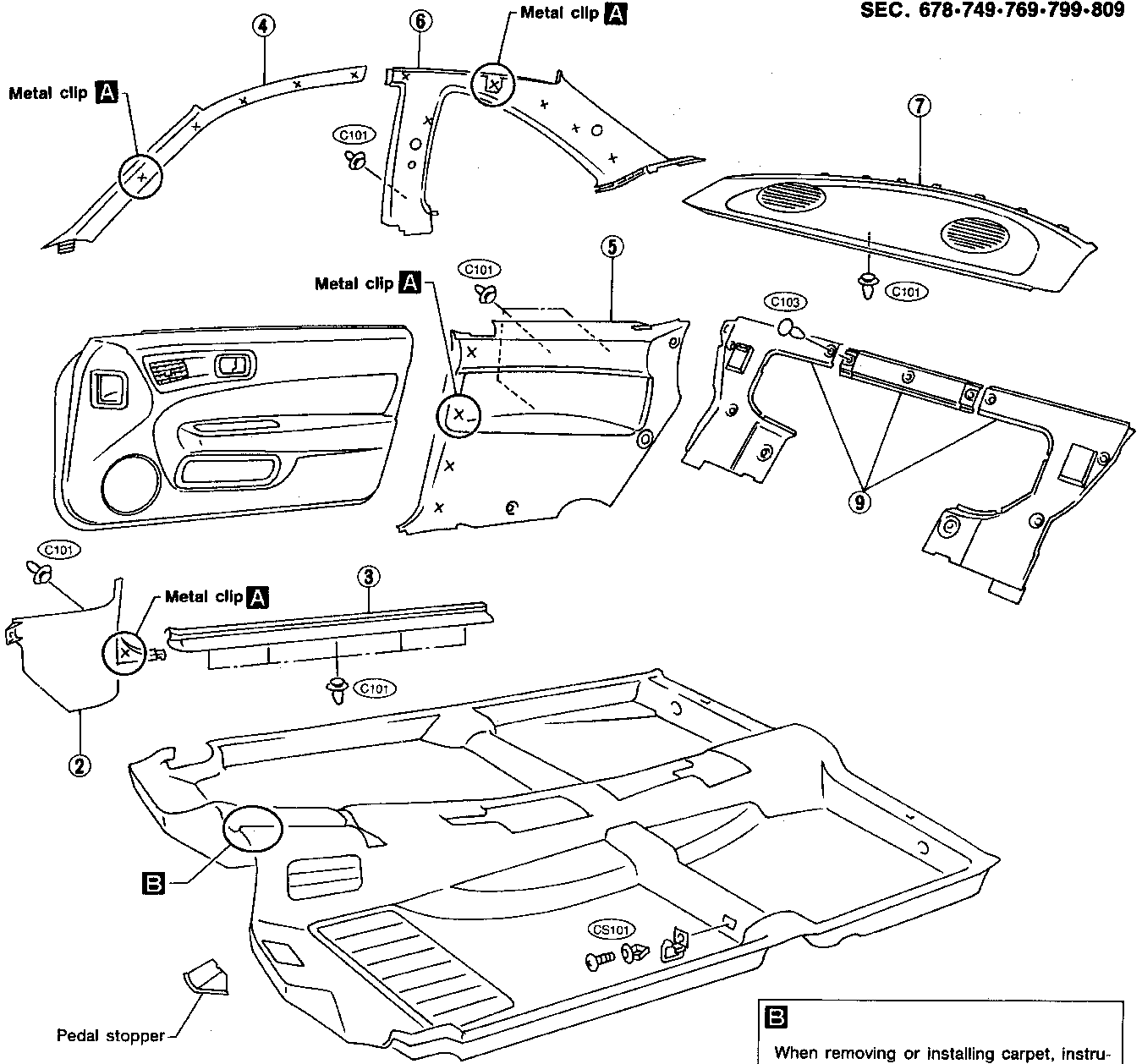

INTERIOR AND EXTERIOR

Interior (Cont'd)

DOOR TRIM

REMOVAL — Door trim

- 1 Remove screws securing inside handle escutcheon **A** .
- 2 Remove power window switch **B** .
- 3 Remove screws securing door finisher.
- 4 Remove clips securing door finisher.
- 5 Pull door finisher to remove clips **(C101)** and metal clips **C** from door panel and remove door finisher. Disconnect main and door harnesses.
- 6 Remove ventilator grille and ventilator duct assembly from door finisher **D** .

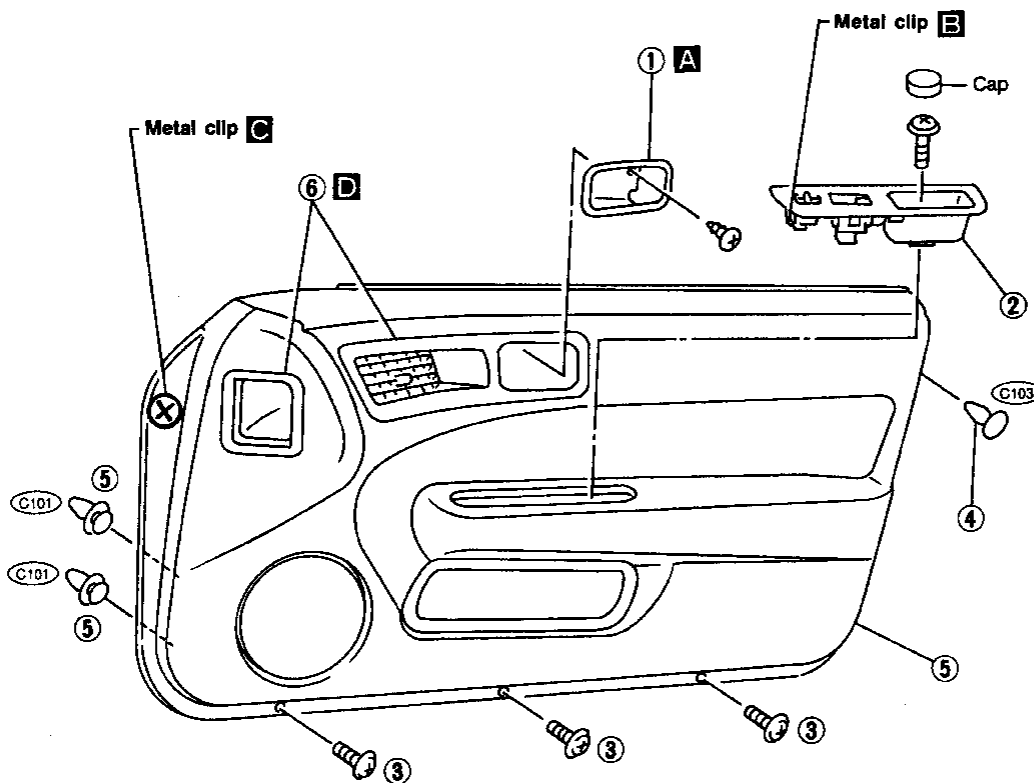

SEC. 809

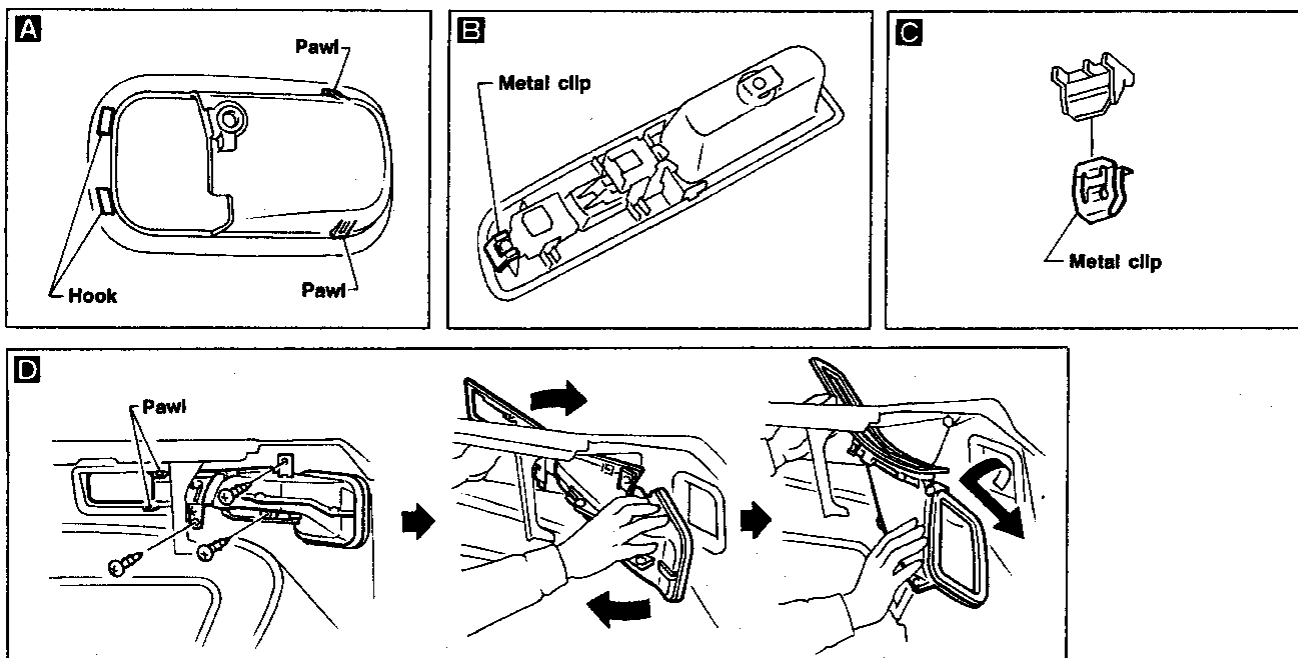

MBF447B

INTERIOR AND EXTERIOR

Interior (Cont'd)

ROOF TRIM

REMOVAL — Headlining

- ① Remove rear seat. Refer to "Rear Seat" for details.
- ② Remove seat belt adjuster cover over anchor bolt.
- ③ Remove front and rear seat belts. Refer to "Seat Belt" for details.
- ④ Remove body side trim. Refer to "REMOVAL — Body side trim" for details (BF-50).
- ⑤ Remove sunroof switch **A**.
- ⑥ Remove inside mirror assembly.
- ⑦ Remove sun visors **B**.
- ⑧ Remove interior lamp assembly.
- ⑨ Remove sunroof welt **C**.
- ⑩ Remove clips **C103** securing each side of headlining.
- ⑪ Remove metal clips securing headlining **D**.
- ⑫ Remove headlining.

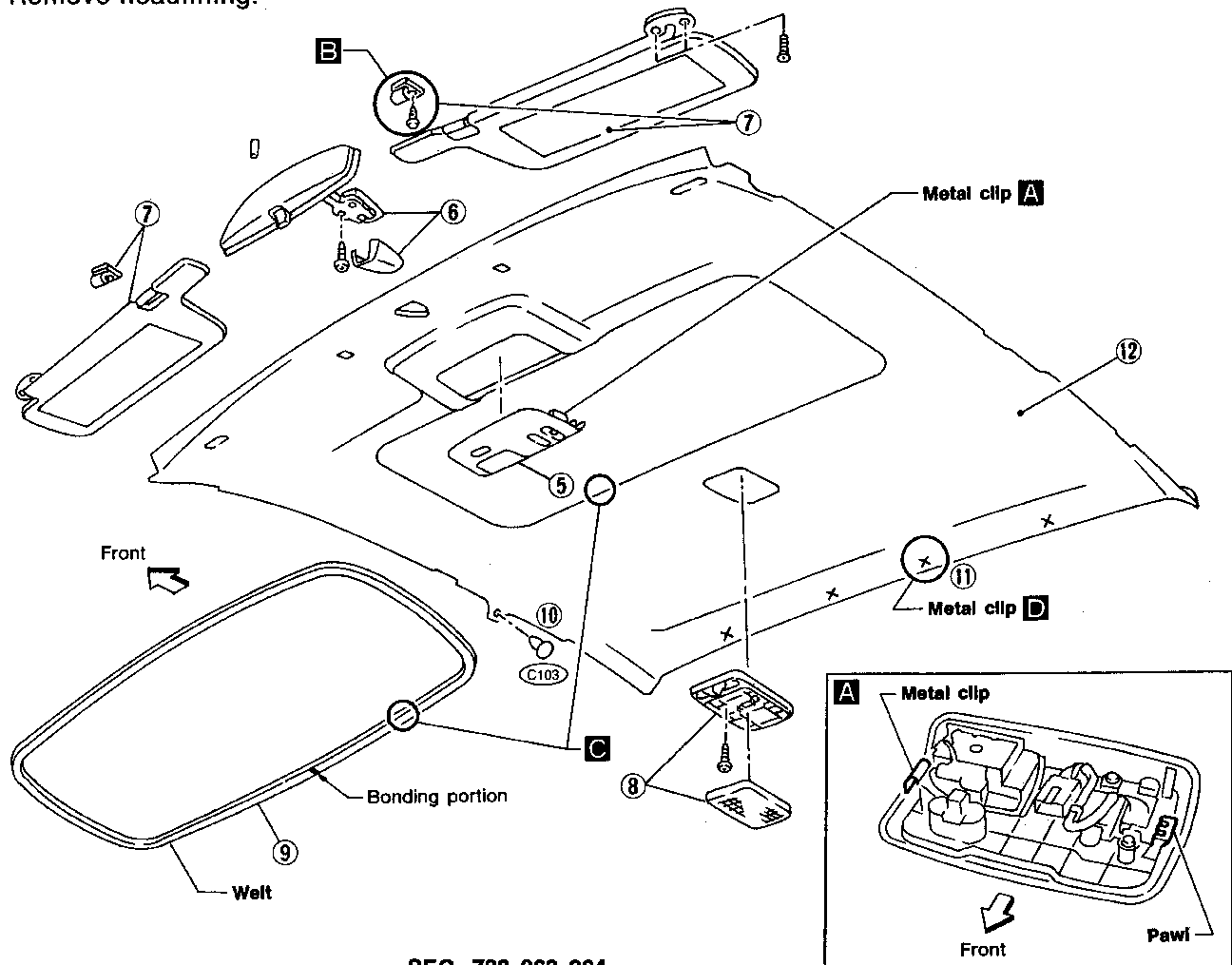

SEC. 738-963-964

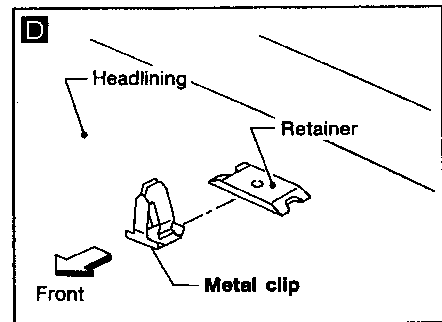
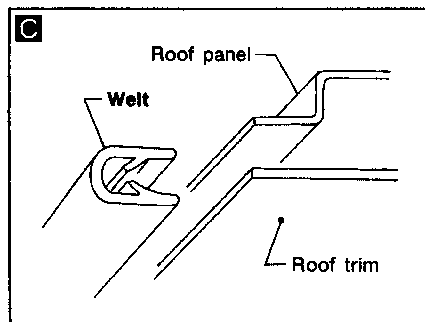
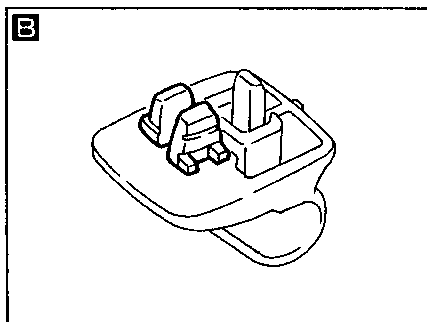

MBF446B

GI
MA
EM
LC
EC
FE
CL
MT
AT
PD
FA
RA
BR
ST
BF
HA
EL
IDX

INTERIOR AND EXTERIOR

Interior (Cont'd)

LUGGAGE ROOM TRIM

SEC. 799-849

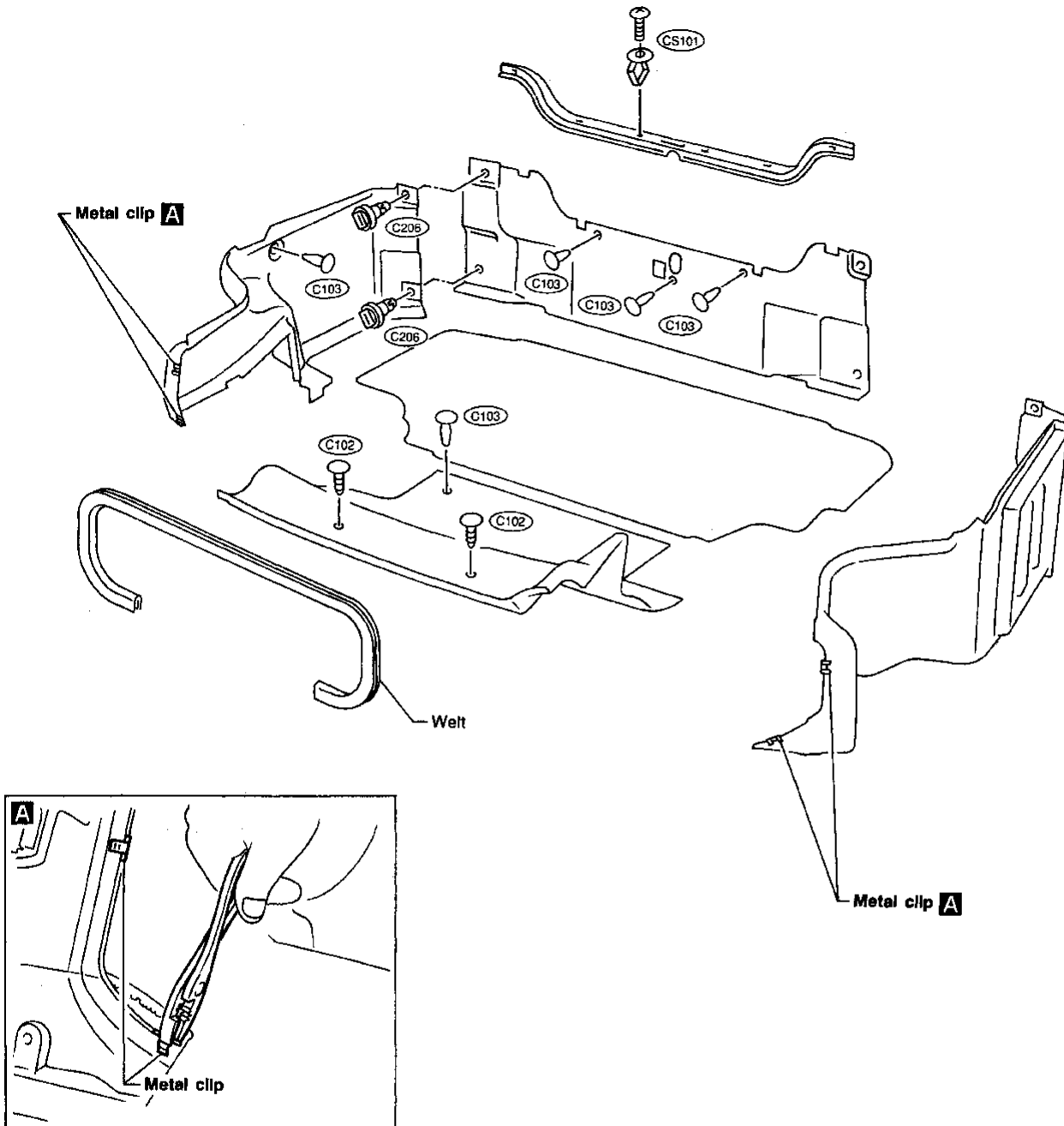

MBF448B

INTERIOR AND EXTERIOR

Exterior

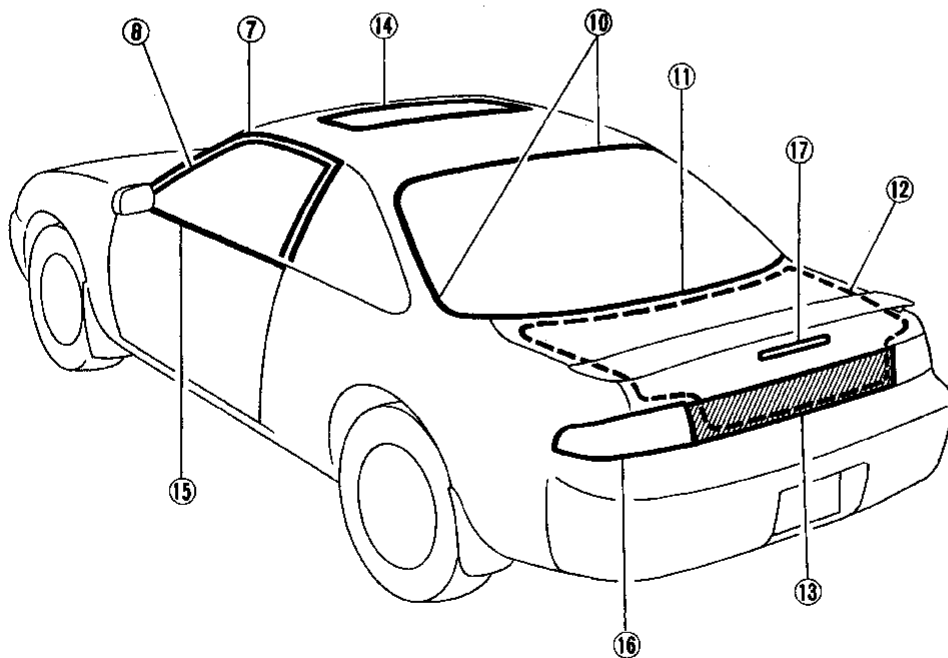
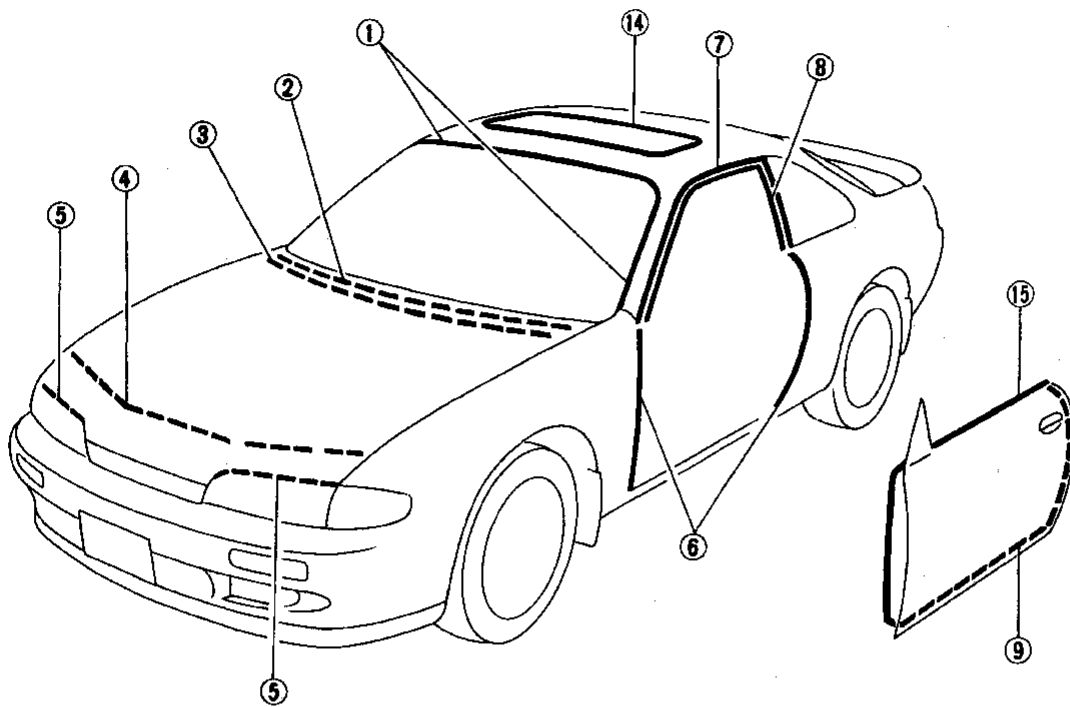

GI

MA

EM

LC

EC

FE

CL

MT

AT

PD

FA

RA

BR

ST

BF

HA

EL

IDX

INTERIOR AND EXTERIOR

Exterior (Cont'd)

① Windshield upper and side molding

Method 1

Cut off top portion of molding and clean glass and panel surfaces.

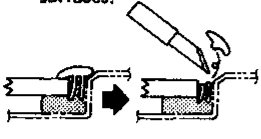

Apply sealant to top portion of molding.

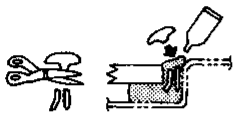

Cut off lower portion of new molding.



Finish well to give it a good appearance.

Method 2

1. Cut off sealant at glass end.
2. Clean the side on which panel was mounted.
3. Set molding fastener and apply sealant to body panel, and apply primer to molding and body.

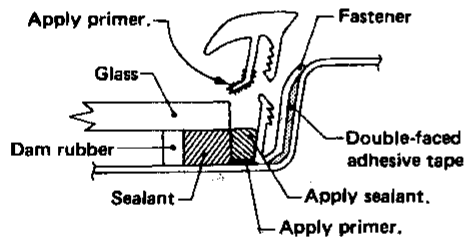

4. Install molding by aligning the molding mark located on center with vehicle center. Be sure to install tightly so that there is no gap around the corner.

SBF161E

②, ③ Cowl top grille and hood rear sealing rubber

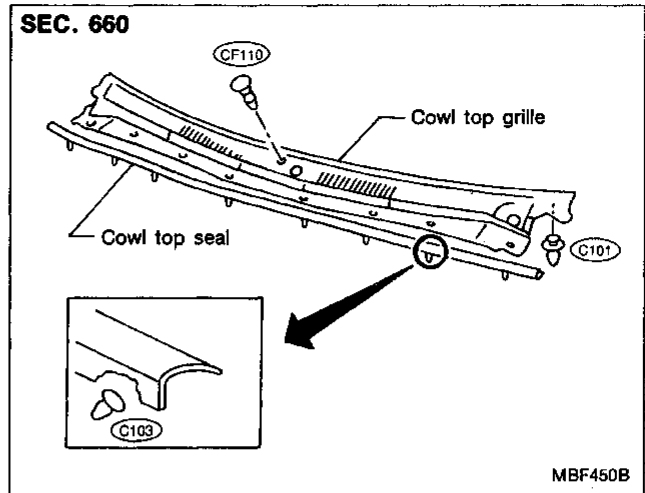

④, ⑤ Hood front sealing rubber

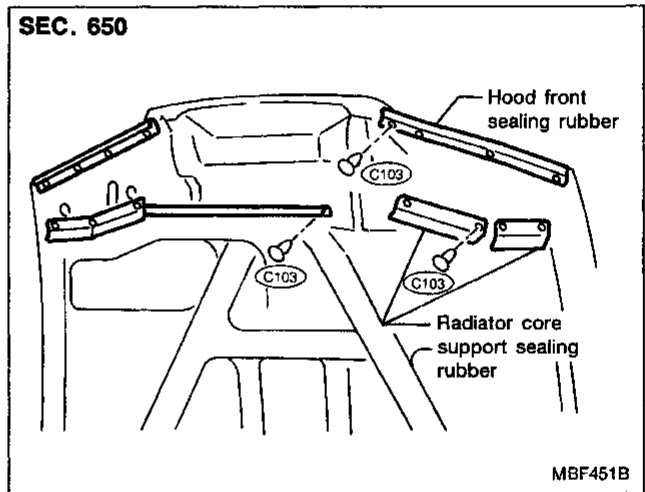

⑥ Body side welt

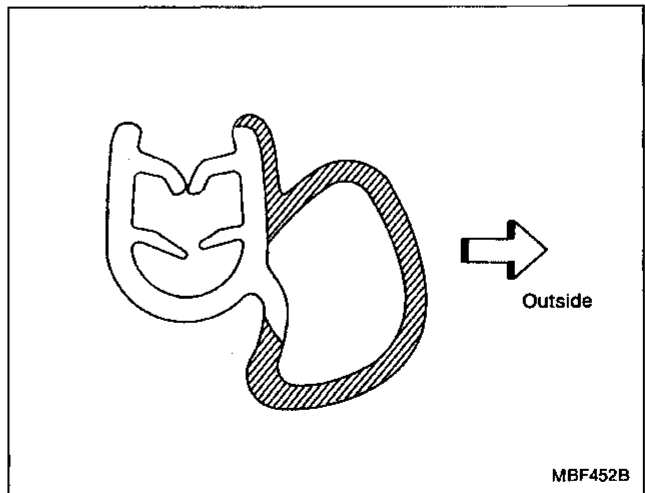

INTERIOR AND EXTERIOR

Exterior (Cont'd)

⑦, ⑧ Body side weatherstrip and weatherstrip retainer

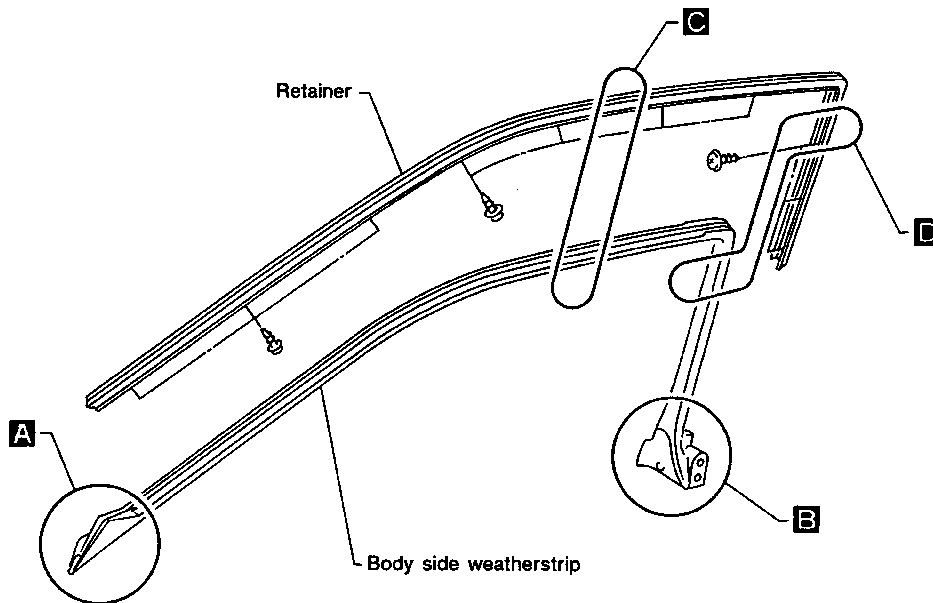

SEC. 766

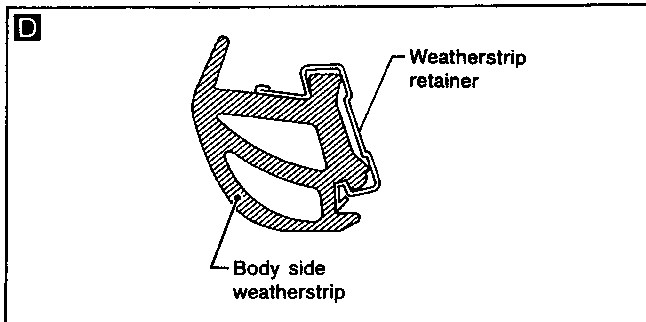
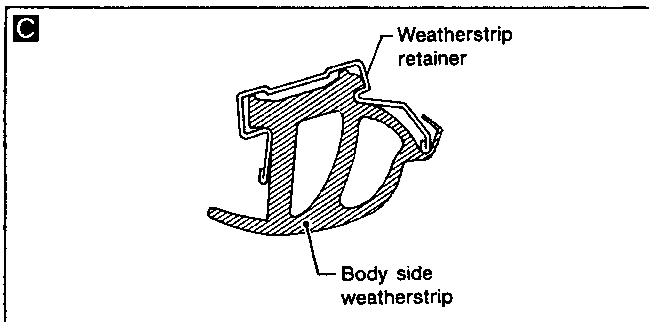
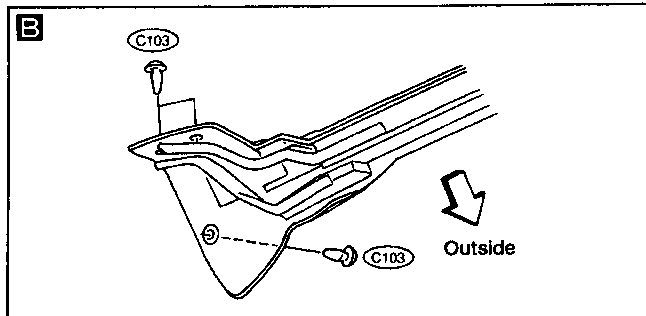
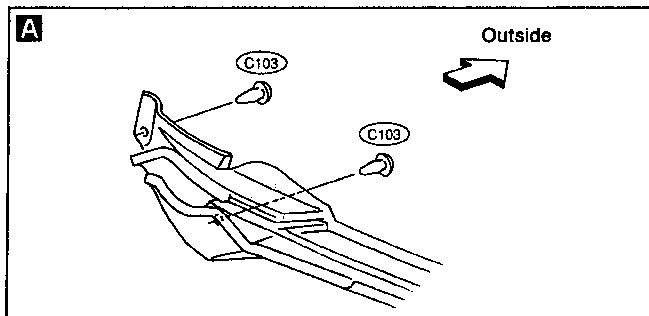

GI

MA

EM

LC

EC

FE

CL

MT

AT

PD

FA

RA

BR

ST

BF

HA

EL

IDX

MBF453B

INTERIOR AND EXTERIOR

Exterior (Cont'd)

⑨ Door weatherstrip

Before removing door weatherstrip, remove door trim. Refer to "DOOR TRIM REMOVAL" for details.

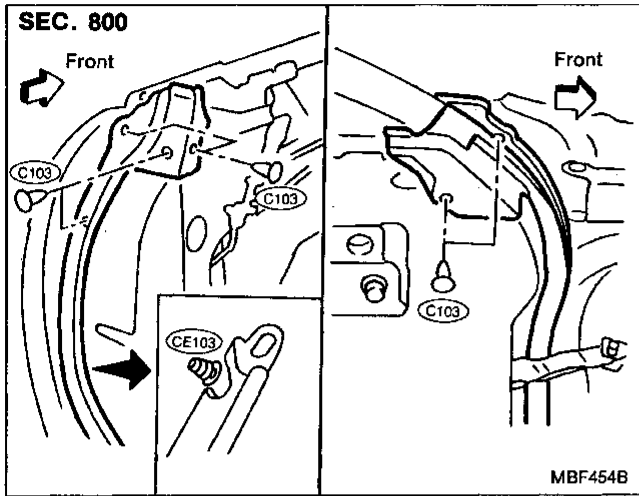

⑩ Back window upper and side molding (SEC. 797)

Basically the same as windshield upper and side molding.

⑪ Back window lower molding (SEC. 797)

It is mounted with screws.

⑫ Trunk lid weatherstrip

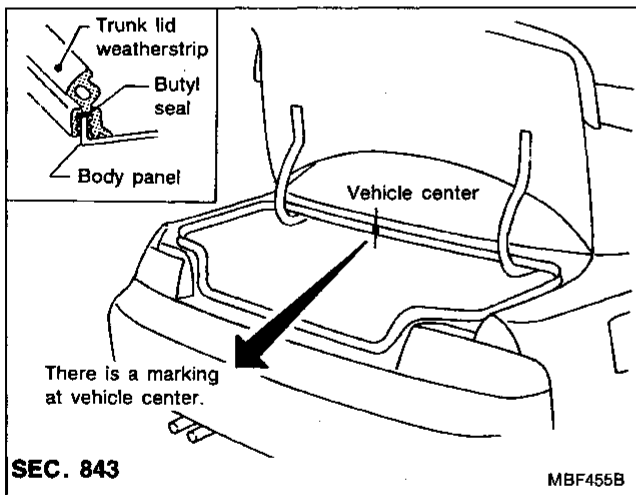

⑬ Rear panel finisher

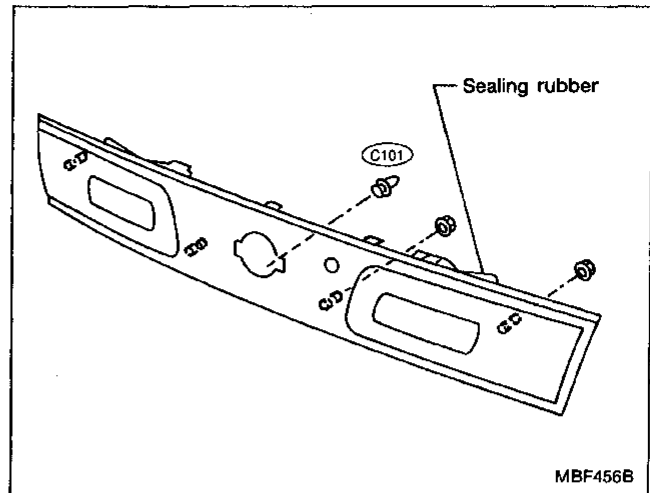

⑭ Sun roof lid weatherstrip

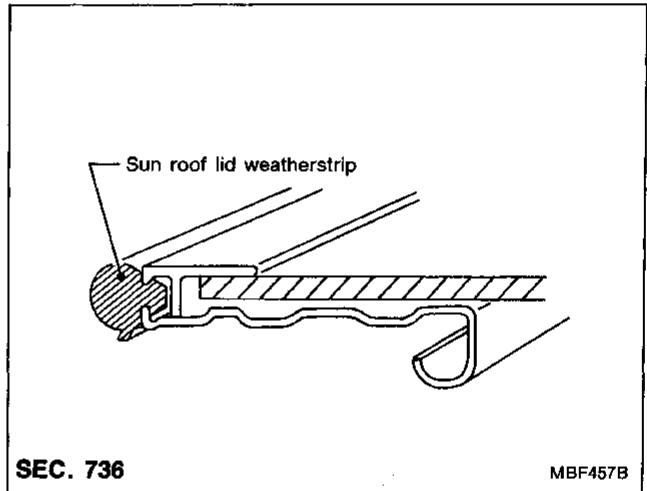

⑮ Door waist outside molding

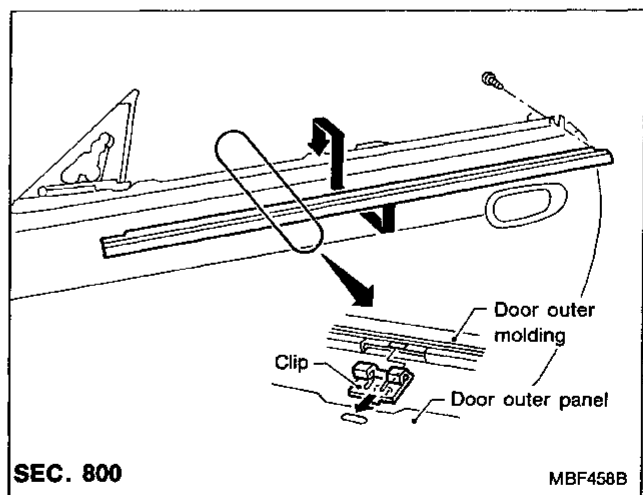

INTERIOR AND EXTERIOR

Exterior (Cont'd)

16 Rear combination lamp

SEC. 265

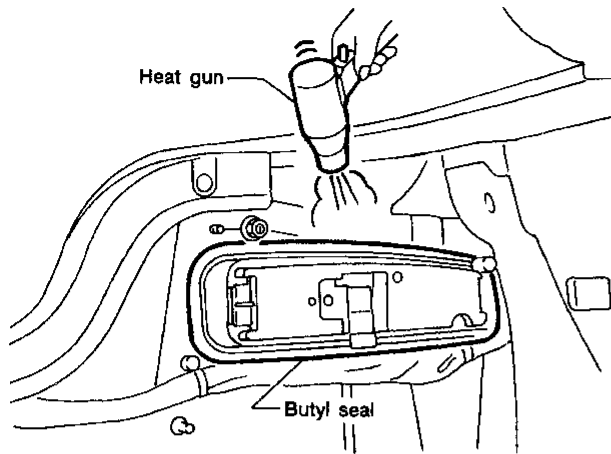

- Warm up lamp assembly area to a temperature a little below 60°C (140°F).

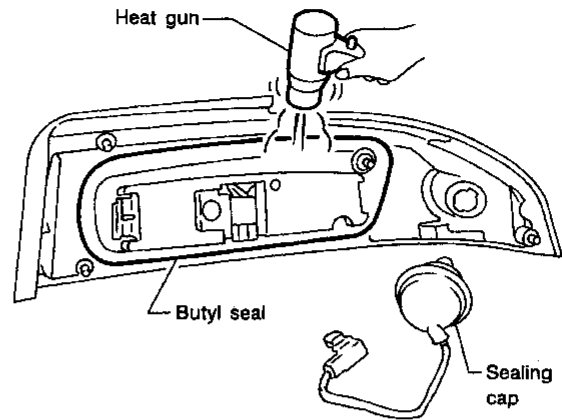

- Apply butyl seal evenly as it tends to become thin in the corners.
- Warm up lamp assembly area to a temperature a little below 60°C (140°F).

MBF459B

GI
MA
EM
LC
EC
FE
CL

MT

AT

PD

FA

RA

BR

ST

BF

HA

EL

IDX

17 High-mounted stop lamp

SEC. 268

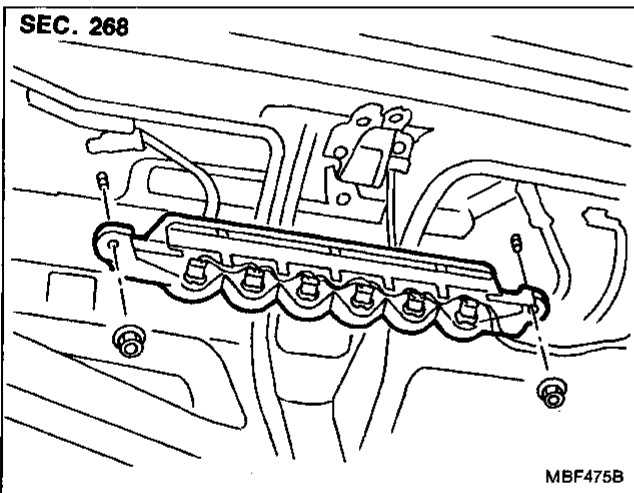

SEAT

- When removing or installing the seat trim, carefully handle it to keep dirt out and avoid damage.

Front Seat

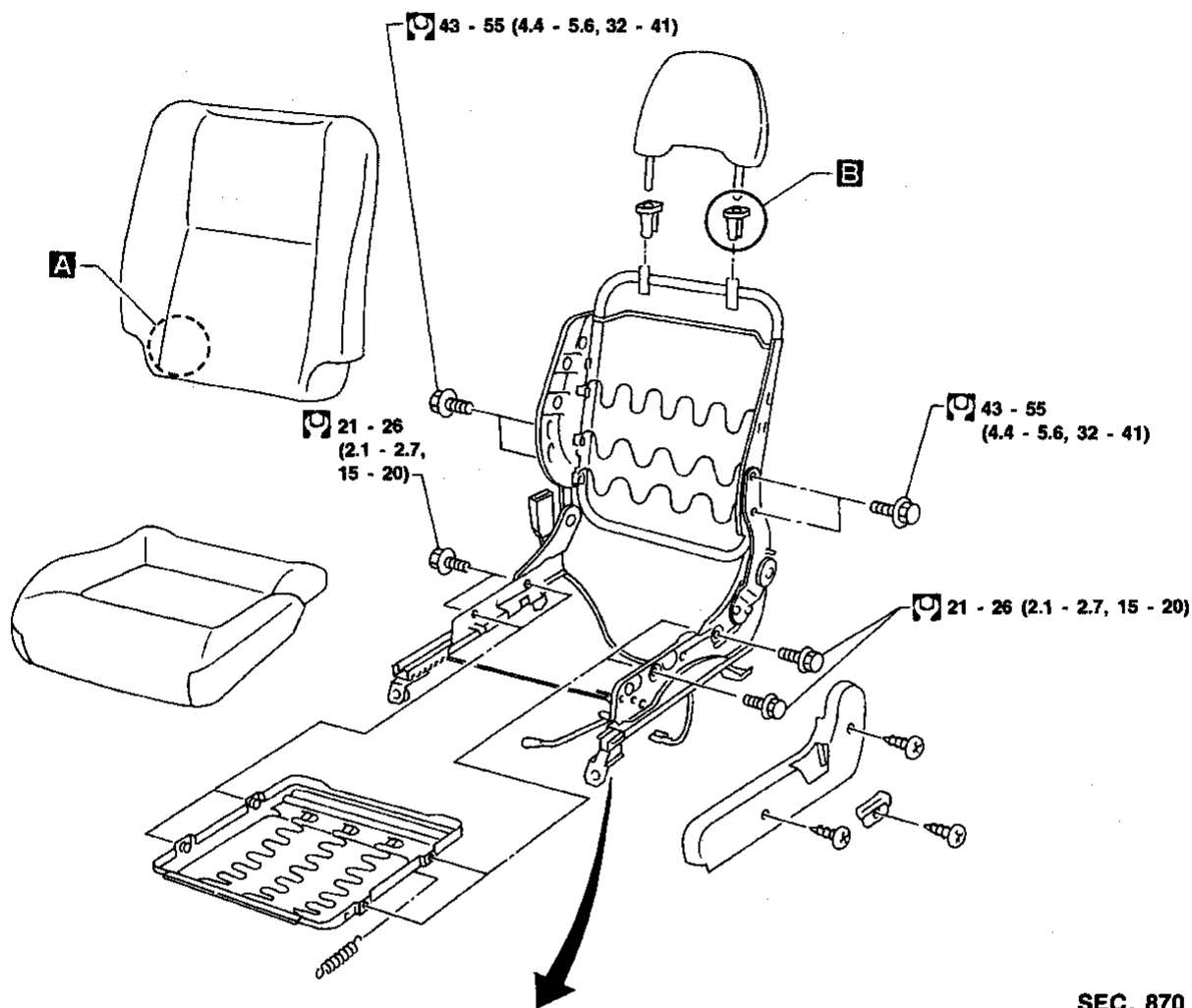

SEC. 870

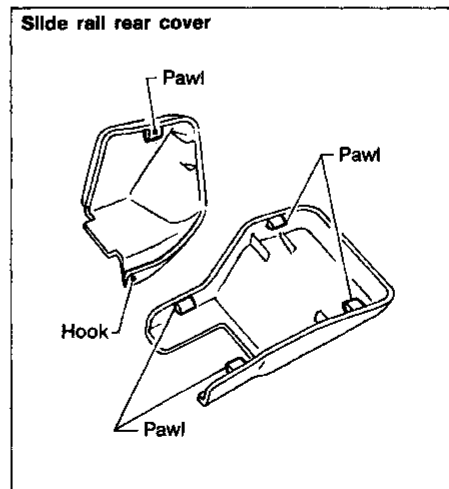
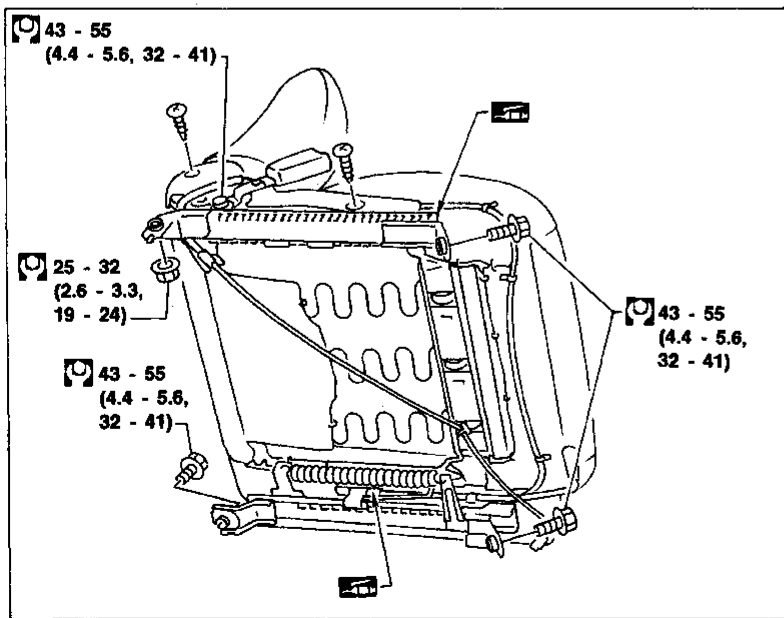

: N·m (kg-m, ft-lb)

MBF460B

BF-60

SEAT

Front Seat (Cont'd)

Remove retainer from lower side of seatback with fingers.

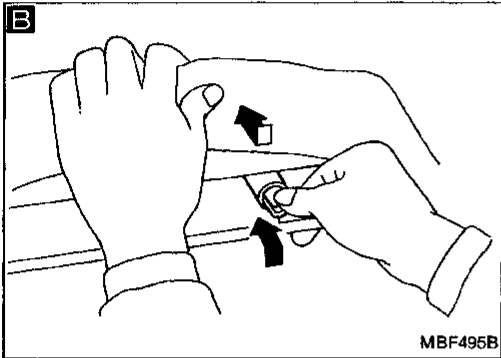
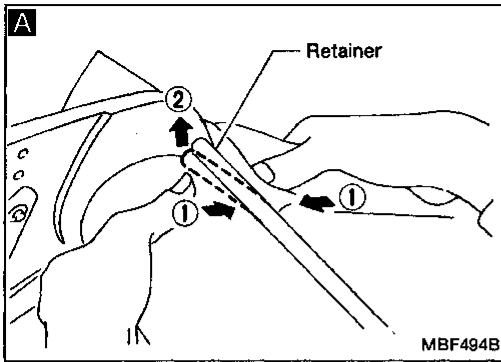

Roll up seatback trim all the way to gain access to headrest holder pawls. Disengage and push headrest holder pawls to unlock holder. Lift off headrest holder.

GI

MA

EM

LC

EC

FE

CL

MT

AT

PD

FA

RA

BR

ST

BF

HA

EL

IDX

SEAT

Rear Seat

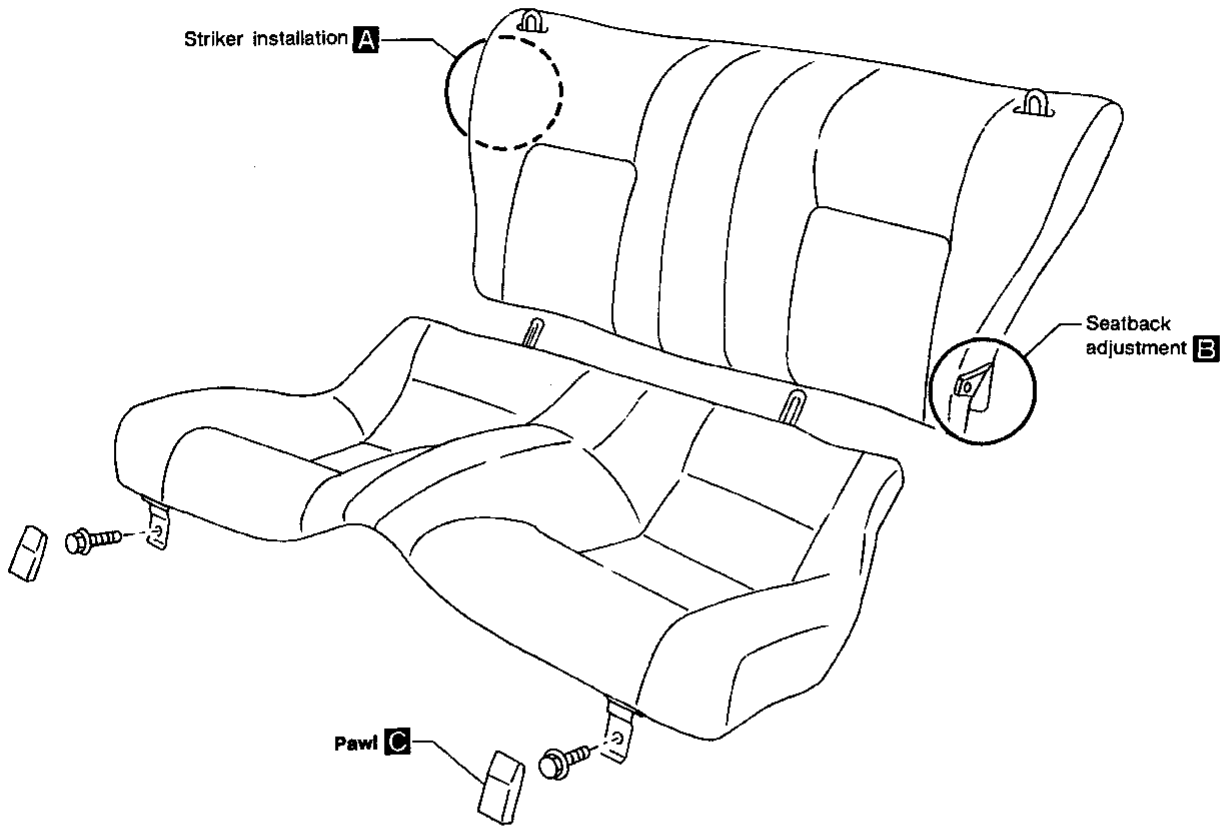

SEC. 880

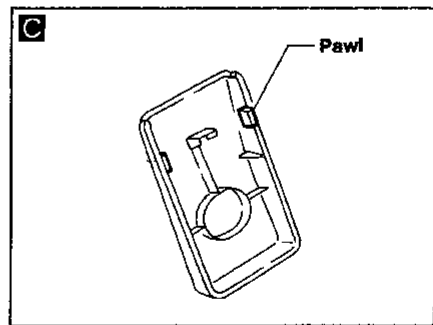
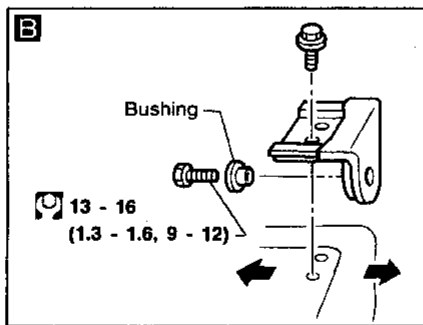
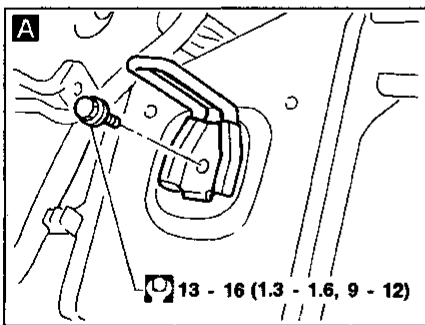

: N·m (kg·m, ft·lb)

SEAT BELTS

CAUTION:

- Do not disassemble buckle or ELR assembly.
- Replace anchor bolts if they are deformed or worn out.

Front Seat Belt

1. Remove rear seat. Refer to "Rear Seat" for details.
2. Remove rear pillar lower garnish. Refer to "SIDE AND FLOOR TRIM" for details.
3. Remove floor anchor cover and the anchor bolt.
4. Remove pillar anchor cover and the anchor bolt.
5. Remove the screw and the anchor bolt securing ELR assembly.

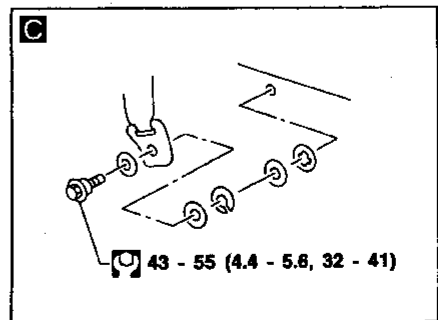
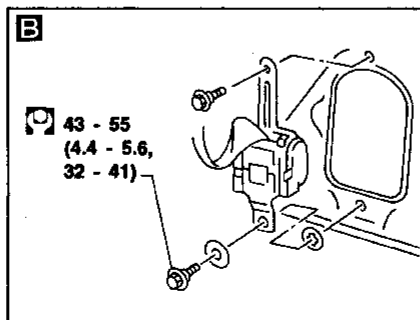
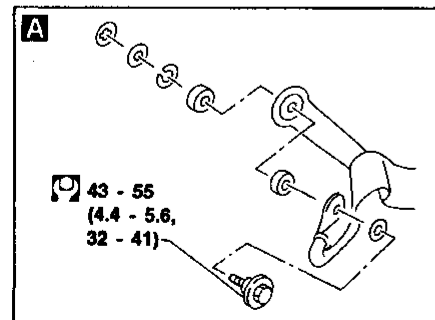
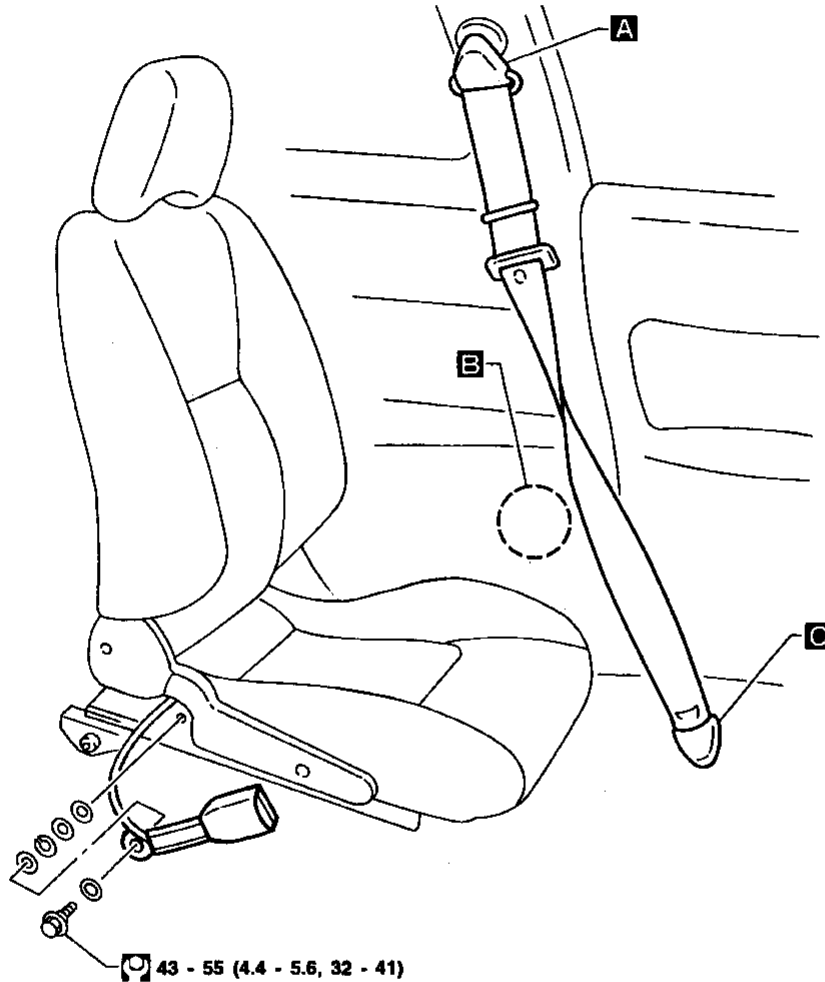

SEC. 868

: N·m (kg-m, ft-lb)

GI
MA
EM
LC
EC
FE
CL
MT
AT
PD
FA
RA
BR
ST
BF
HA
EL
IDX

SEAT BELTS

Rear Seat Belt

1. Remove rear seat. Refer to "Rear Seat" for details.
2. Remove rear pillar lower garnish. Refer to "SIDE AND FLOOR TRIM" for details.
3. Remove each anchor bolt.
4. Remove the anchor bolt securing ELR assembly.

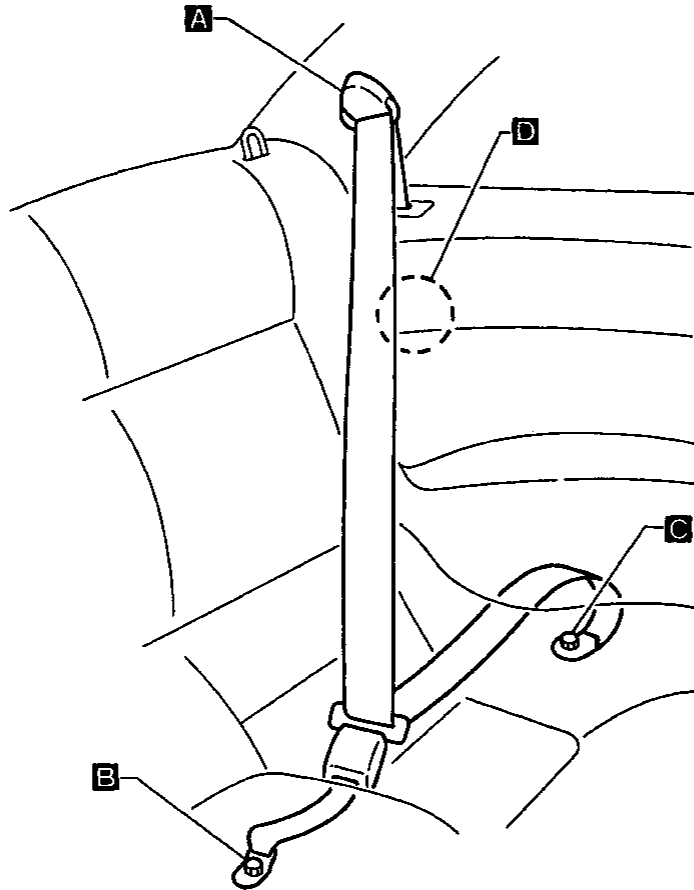

SEC. 869

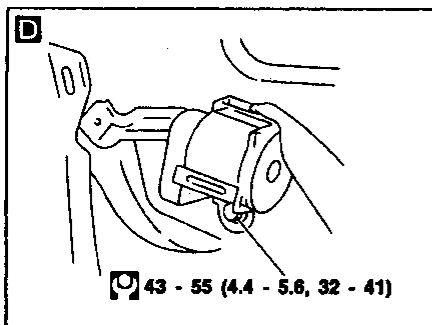
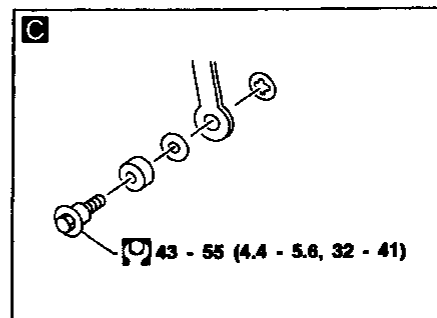
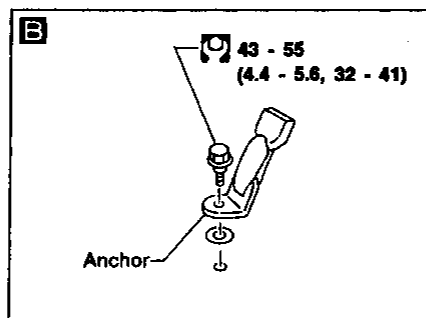
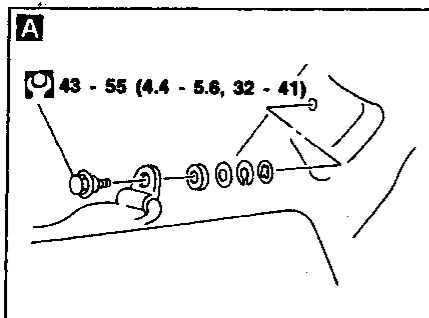

: N·m (kg-m, ft-lb)

MBF497B

SUN ROOF

ADJUSTMENT

Install motor & limit SW assembly and sunroof rail assembly in the following sequence:

1. Arrange equal lengths of link and wire assemblies on both sides of sunroof opening.
2. Connect sunroof connector to sunroof switch and positive (+) power supply.
3. Set lid assembly to fully closed position **A** by operating OPEN switch and TILT switch.
4. Fit outer side of lid assembly to the surface of roof on body outer panel.
5. Remove motor, and keep OPEN switch pressed until motor pinion gear reaches the end of its rotating range.
6. Install motor.
7. Check that motor drive gear fits properly in wires.
8. Press TILT-UP switch to check lid assembly for normal tilting.
9. Check sunroof lid assembly for normal operations (tilt-up, tilt-down, open, and close).

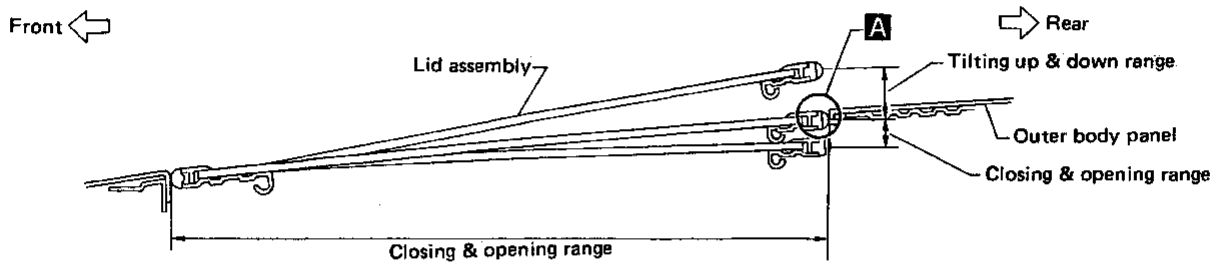

SBF920F

GI

MA

EM

LC

EC

FE

CL

MT

AT

PD

FA

RA

BR

ST

BF

HA

EL

IDX

SUN ROOF

- After any adjustment, check sun roof operation and lid alignment.
- Handle finisher plate and glass lid with care so not to cause damage.
- It is desirable for easy installation to mark each point before removal.

CAUTION:

Always work with a helper.

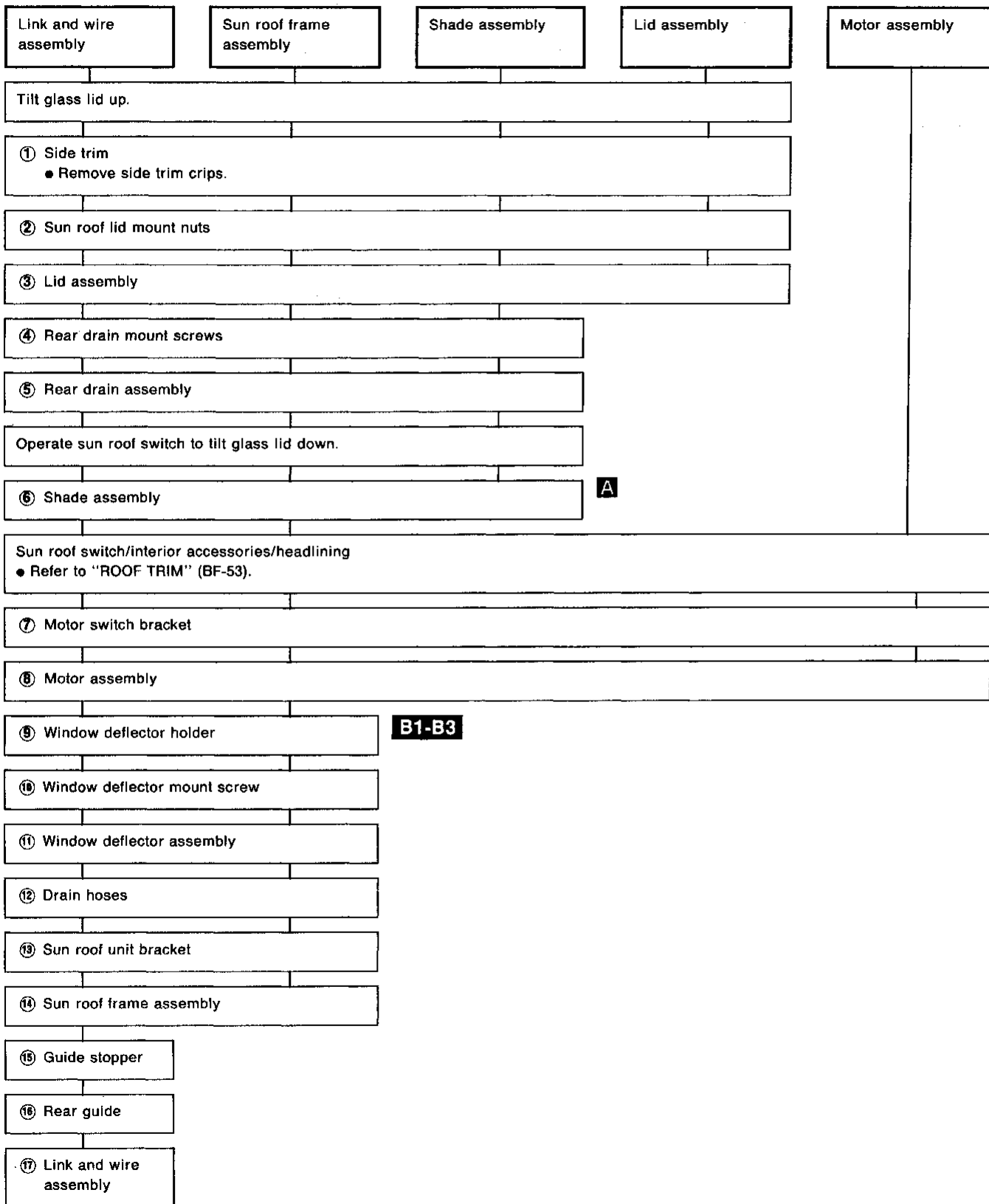

SUN ROOF

SEC. 264-736

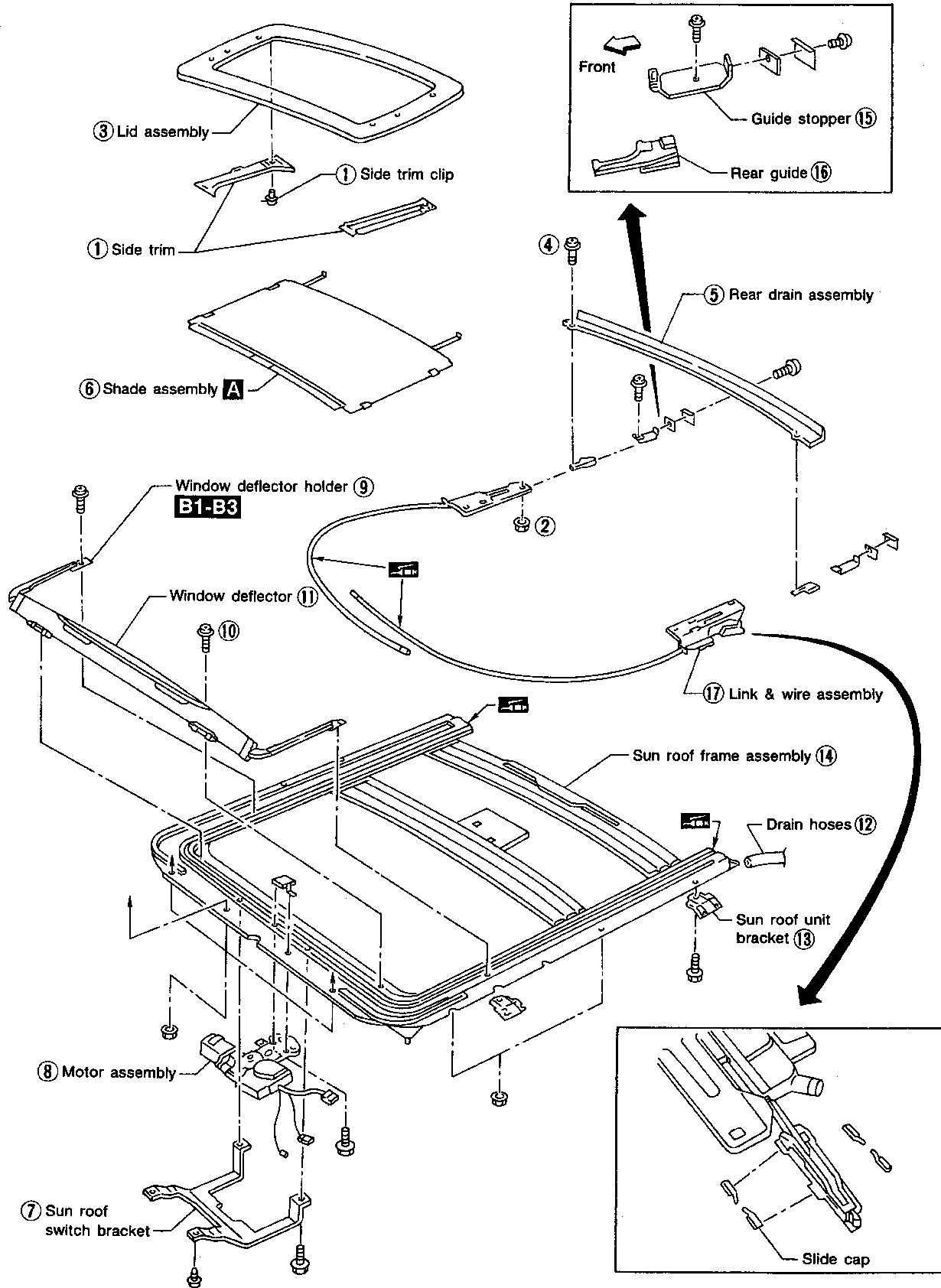

GI
MA
EM
LC
EC
FE
CL
MT
AT
PD
FA
RA
BR
ST
BF
HA
EL
IDX

SUN ROOF

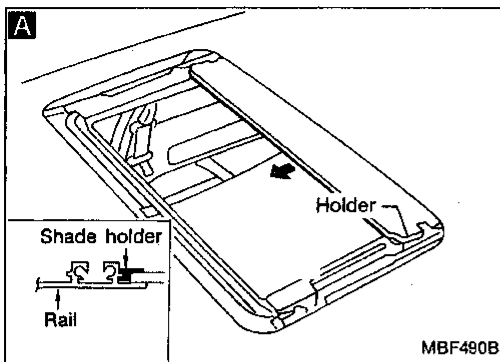

- A** Using flat-bladed screwdriver, pry shade assembly holder off rail. Then pull shade assembly forward to remove it from rail.

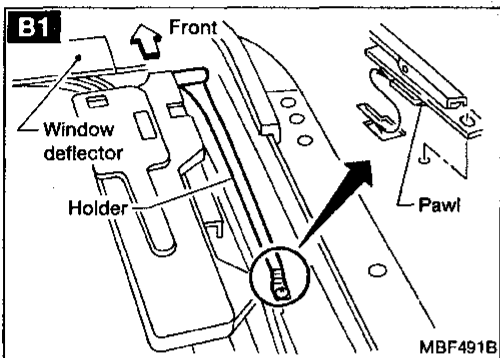

- B1** Disengage pawls from rail, then remove window deflector holder.

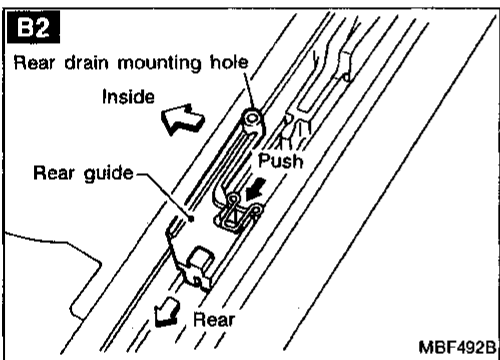

- B2** Using flat-bladed screwdriver, pry stopper spring off rail groove. Then slide rear guide backward to remove it from rail.

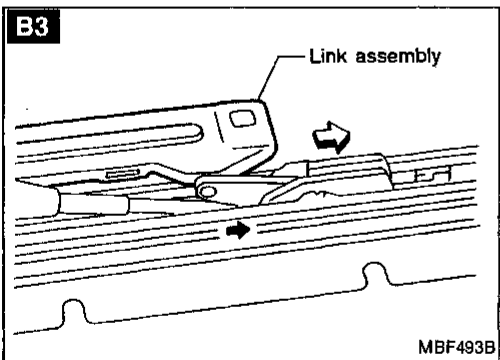

- B3** Remove wire and link assembly from rail while pushing link back with flat-bladed screwdriver.

SUN ROOF

Wiring Diagram — SROOF —

BF-SROOF-01

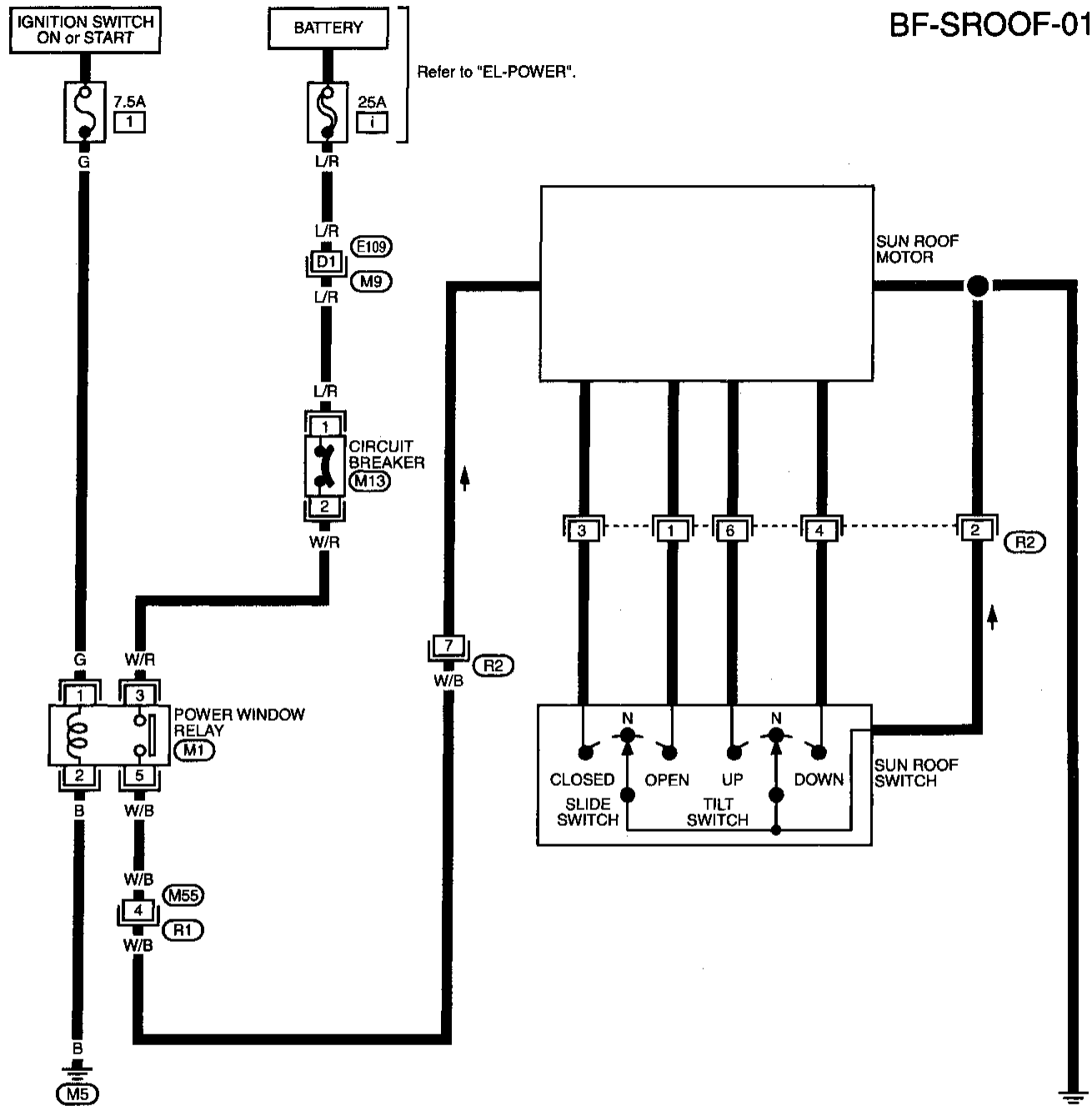

GI
MA
EM
LC
EC
FE
CL
MT
AT
PD
FA
RA
BR
ST

BF

Refer to last page (Foldout page).

(M9), (E109)

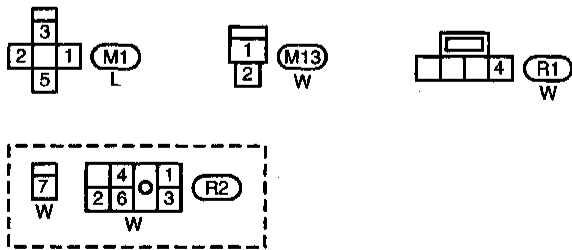

HA
EL
IDX

WINDSHIELD AND WINDOWS

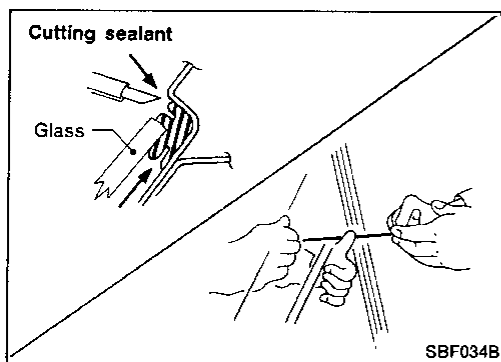

REMOVAL

After removing moldings, remove glass.

CAUTION:

Be careful not to scratch glass when removing.

INSTALLATION

- Use genuine Nissan Sealant kit or equivalent. Follow instructions furnished with it.
- After installation, the vehicle should remain stationary until the sealant hardens.

WARNING:

Keep heat and open flames away as primers are flammable.

CAUTION:

Advise users not to drive the vehicle on rough roads until sealant has properly vulcanized.

- Do not use sealant which is past its usable term.
- Do not leave cartridge unattended with its cap open.
- Keep primers and sealant in a cool, dry place. Ideally, they should be stored in a refrigerator.
- Molding must be installed securely so that it is in position and leaves no gap.

Windshield and Rear Window

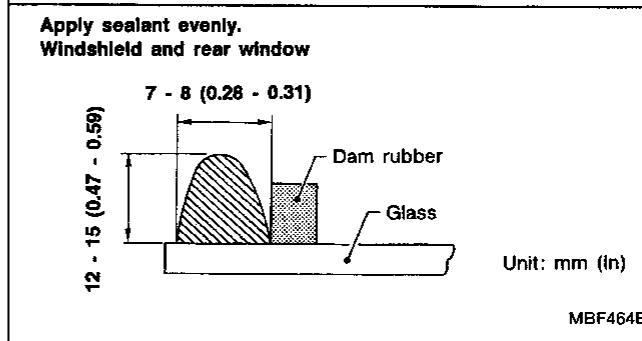
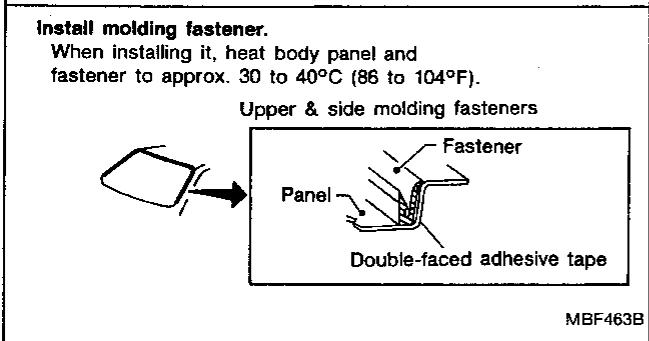
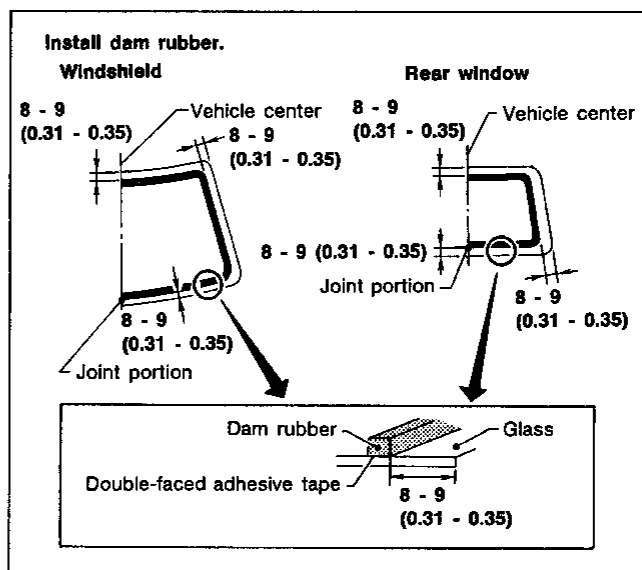
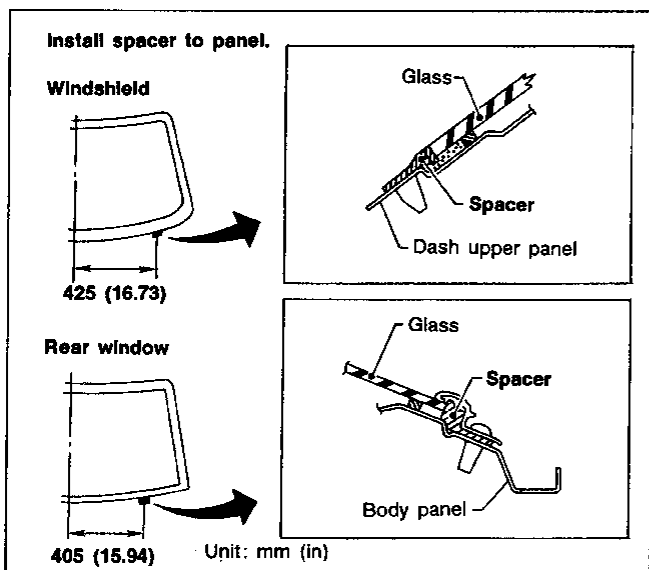

REPAIRING WATER LEAKS FOR WINDSHIELD AND WINDOWS

Leaks can be repaired without removing and reinstalling glass.

If water is leaking between caulking material and body or glass, determine the extent of leaking. This can be determined by applying water while pushing glass outward.

To stop the leak, apply primer and then sealant to the leak point.

WINDSHIELD AND WINDOWS

Side Window

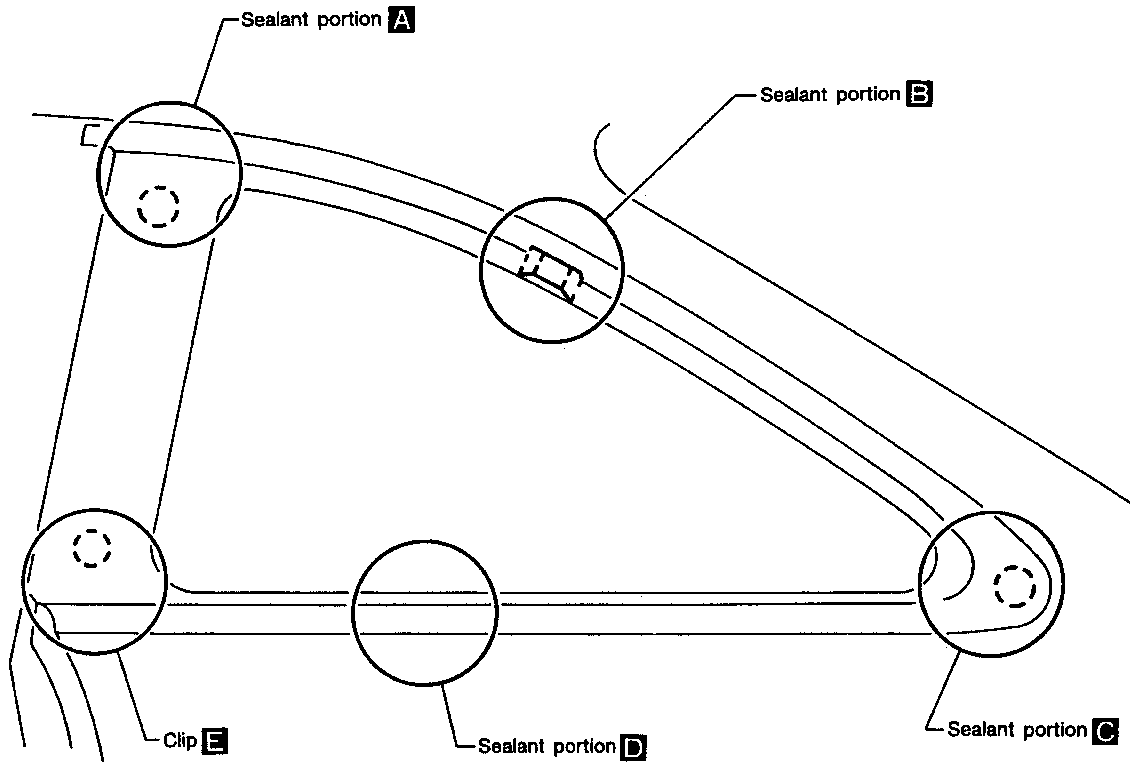

SEC. 830

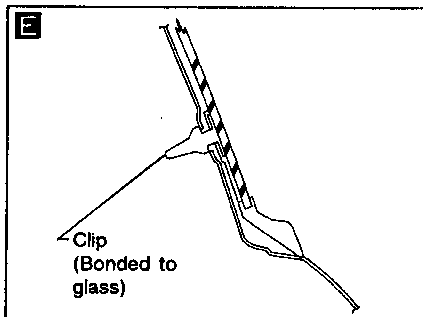
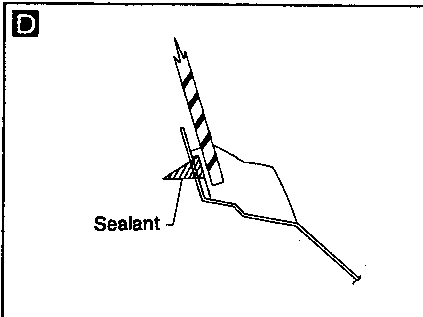
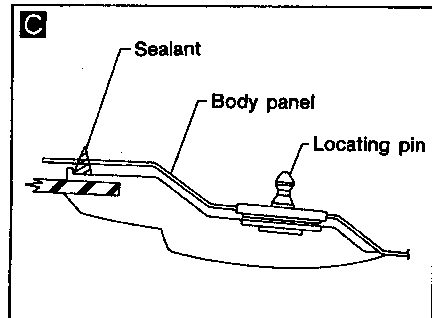
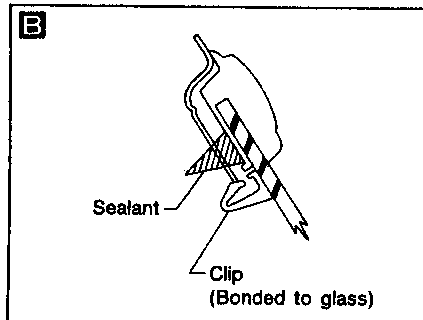
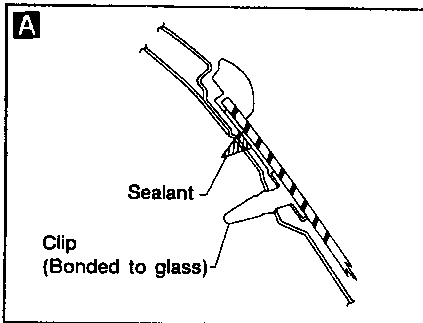

Sealant quantity

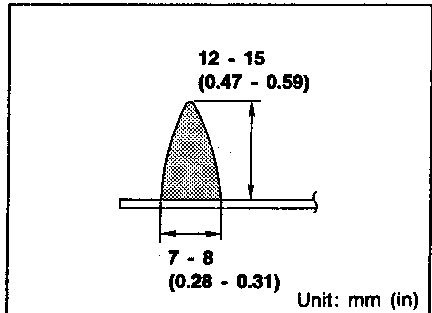

GI
MA
EM
LC
EC
FE
CL
MT
AT
PD
FA
RA
BR
ST
BF
HA
EL
IDX

DOOR MIRROR

CAUTION:

Be careful not to scratch door rearview mirror body.

REMOVAL — Door mirror

- ① Remove door trim. Refer to "REMOVAL — Door trim" in "Interior" for details.
- ② Remove inner cover front corner of door. **A**
- ③ Disconnect door mirror harness connector.
- ④ Remove harness clips.
- ⑤ Remove three bolts securing door mirror.

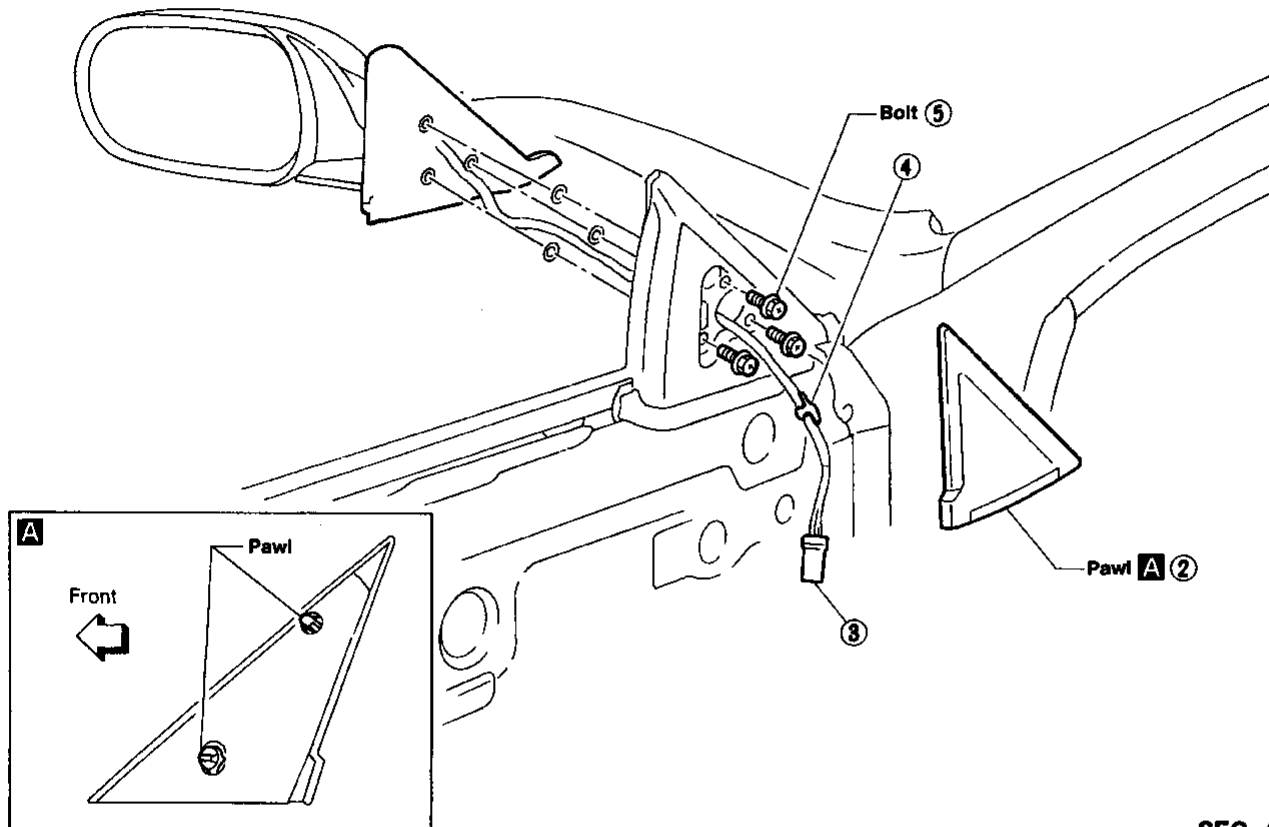

SEC. 963

Removal:

- Wrap flat-bladed of screwdriver with a cloth to prevent scratching rear of door mirror. Do not insert screwdriver too far.

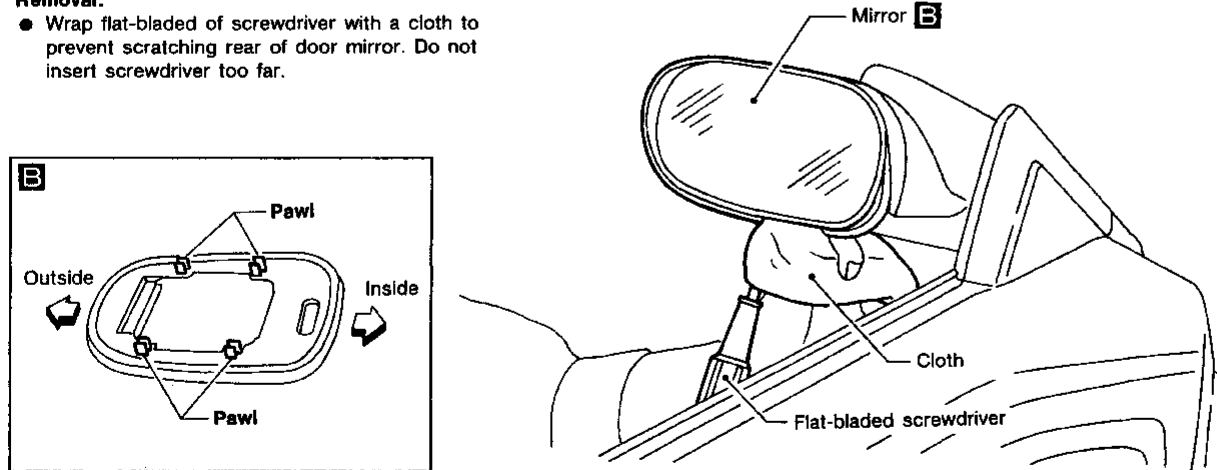

MBF466B

DOOR MIRROR

Wiring Diagram — MIRROR —

BF-MIRROR-01

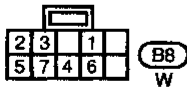
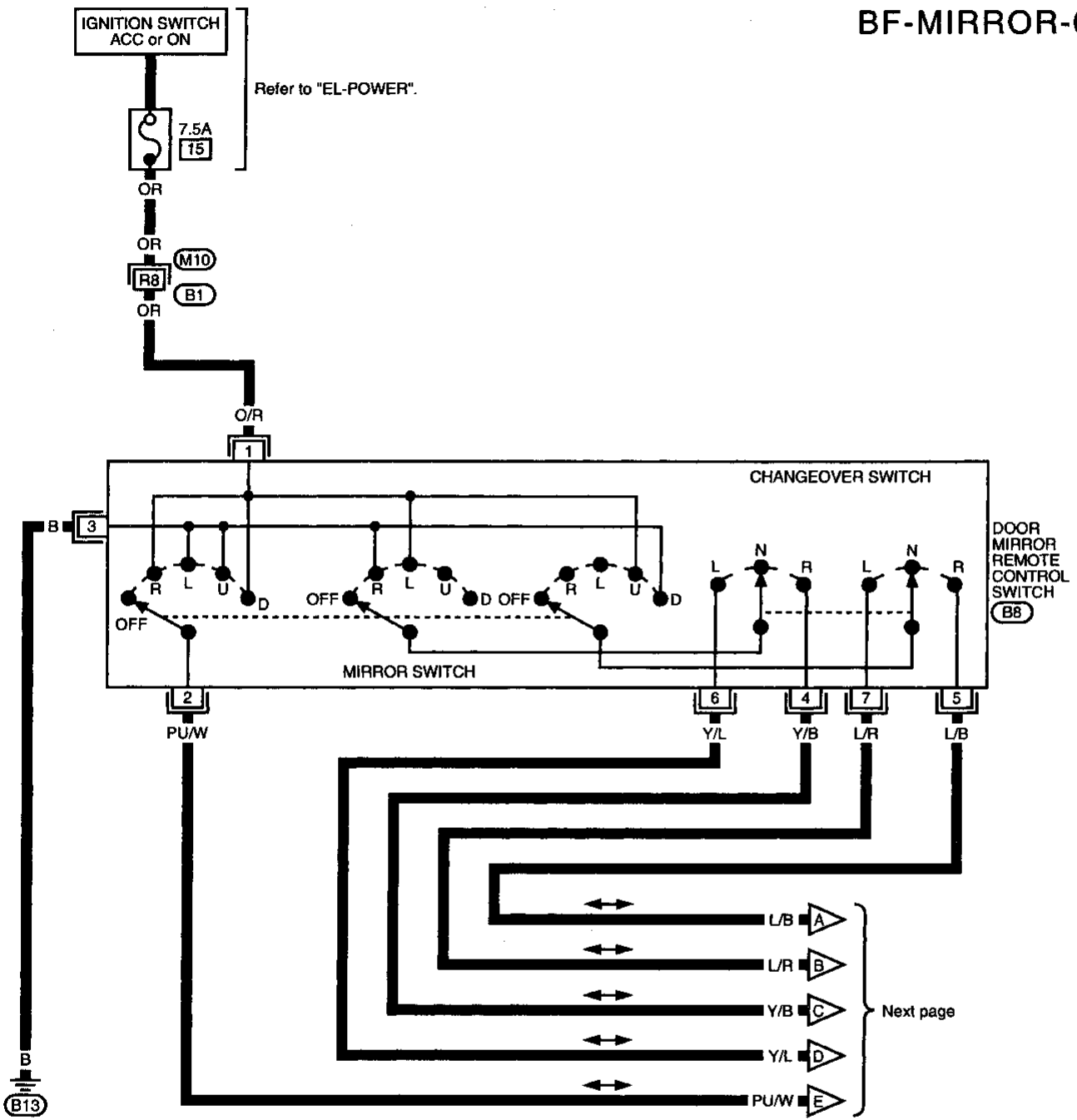

Refer to last page (Foldout page).

M10 . B1

GI
MA
EM
LC
EC
FE
CL
MT
AT
PD
FA
RA
BR
ST
BF
HA
EL
IDX

DOOR MIRROR

Wiring Diagram — MIRROR — (Cont'd)

BF-MIRROR-02

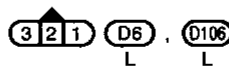
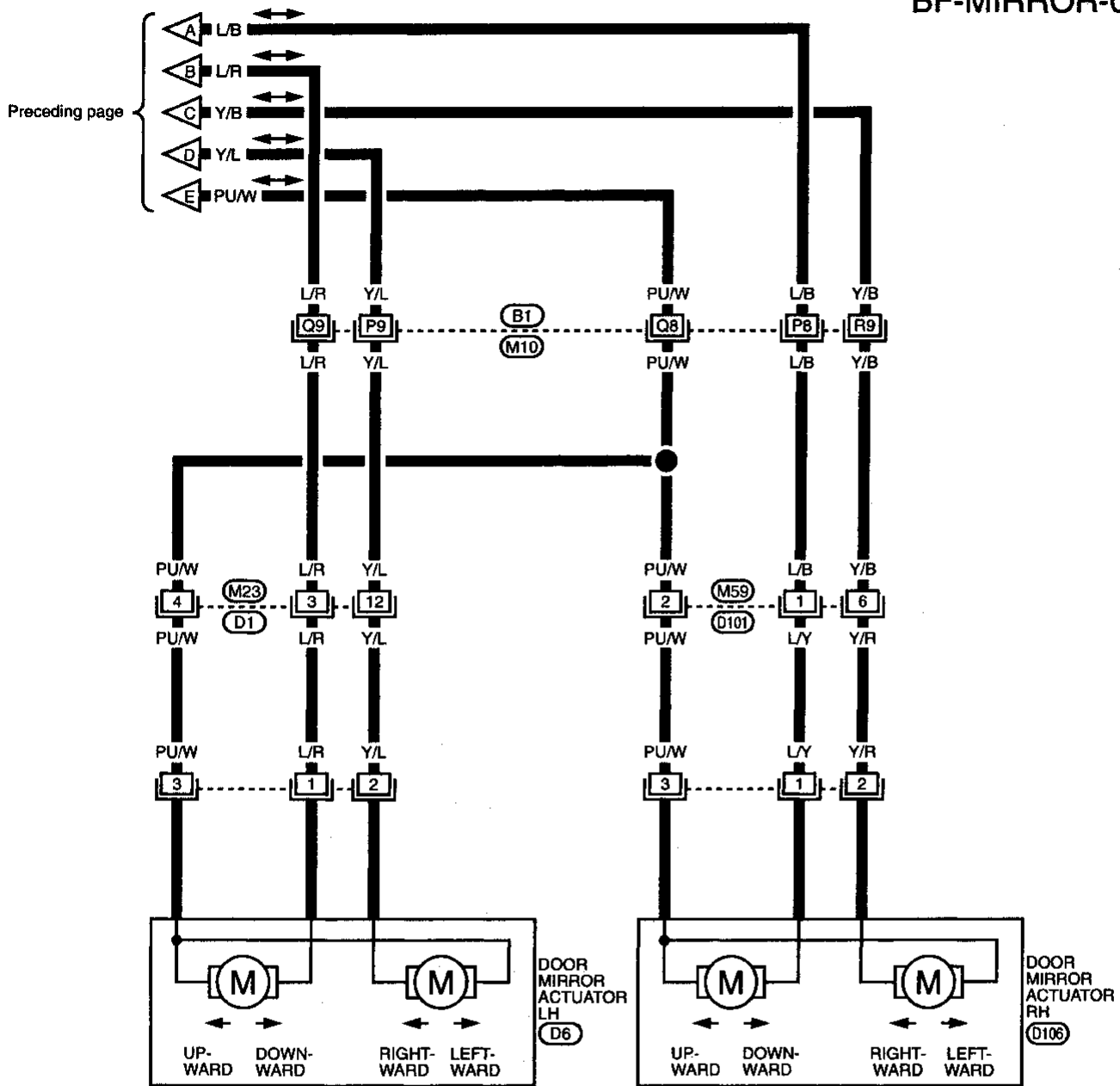

Refer to last page (Foldout page).
 (M10) , (B1)

REAR AIR SPOILER

Rear Air Spoiler

- When installing, make sure that there are not gaps or waves at ends of air spoiler.
- Before installing spoiler, clean and remove oil from surface where spoiler will be mounted.

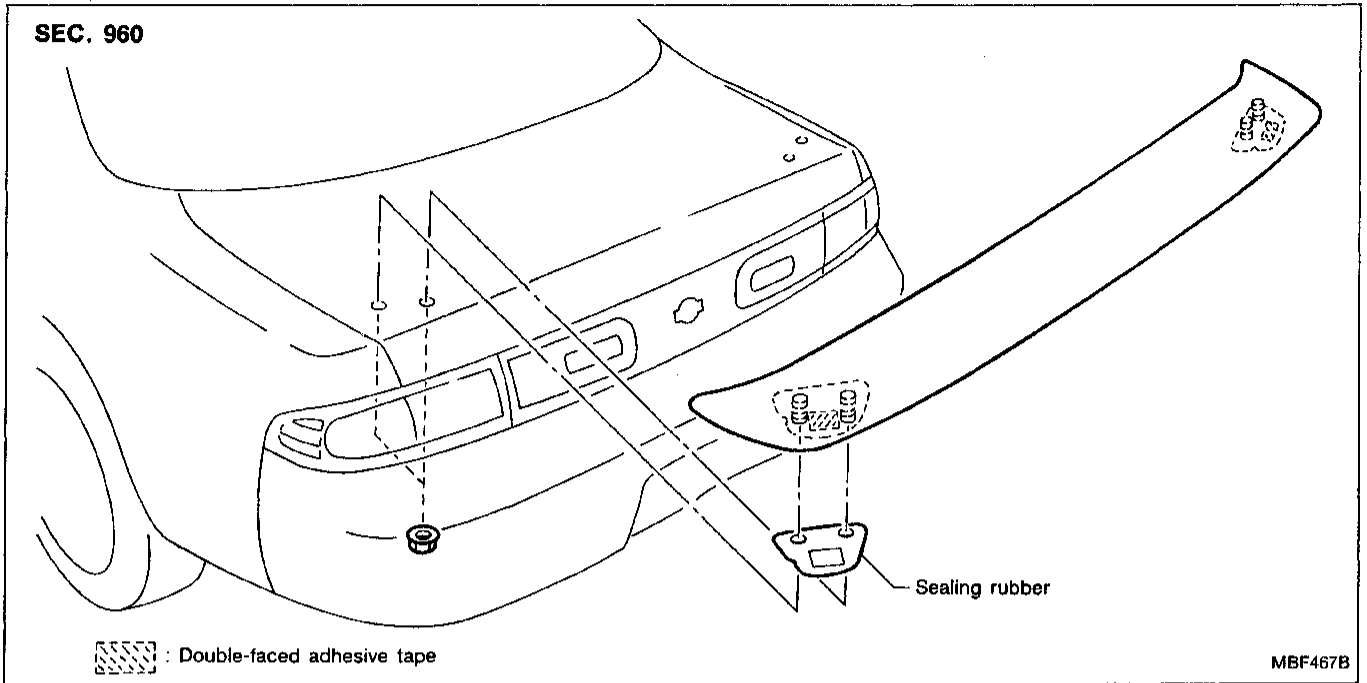

GI

MA

EM

LC

EC

FE

CL

MT

AT

PD

FA

RA

BR

ST

BF

HA

EL

IDX

BODY ALIGNMENT

- All dimensions indicated in figures are actual ones.
- When using a tracking gauge, adjust both pointers to equal length. Then check the pointers and gauge itself to make sure there is no free play.
- When a measuring tape is used, check to be sure there is no elongation, twisting or bending.
- Measurements should be taken at the center of the mounting holes.
- An asterisk (*) following the value at the measuring point indicates that the measuring point on the other side is symmetrically the same value.
- The coordinates of the measurement points are the distances measured from the standard line of "X", "Y" and "Z".

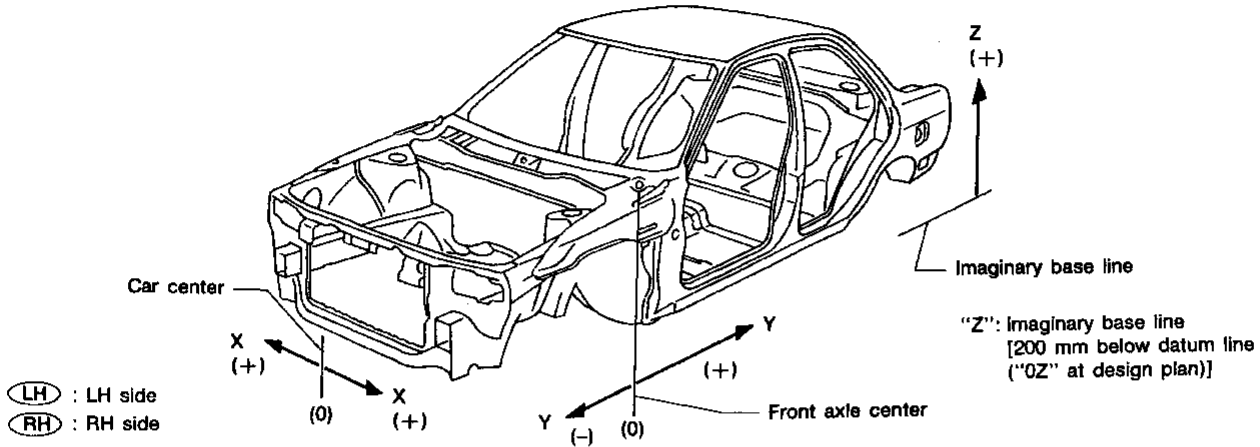

Engine Compartment

SBF874G

MEASUREMENT

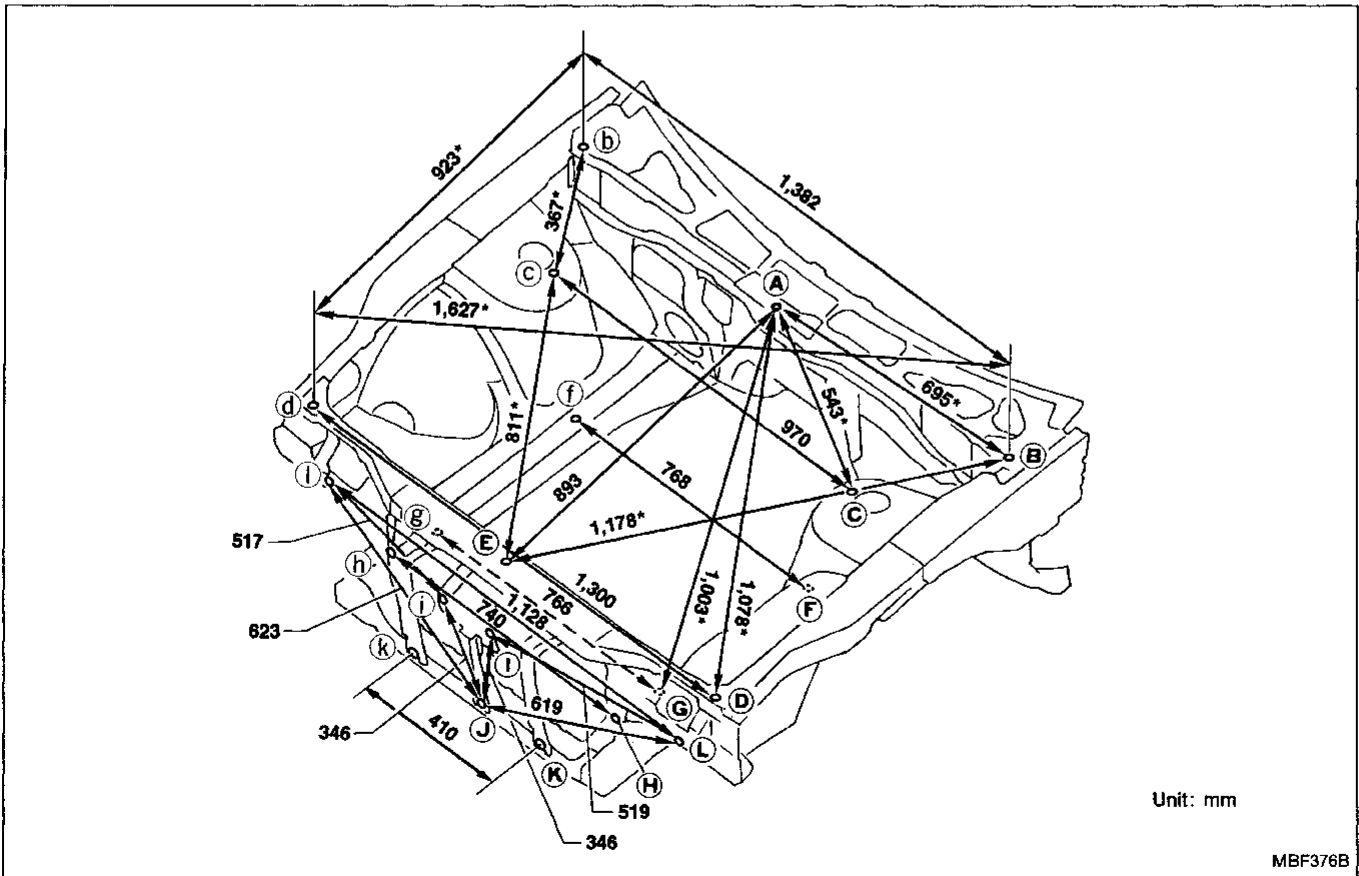

BODY ALIGNMENT

Engine Compartment (Cont'd)

MEASUREMENT POINTS

Unit: mm

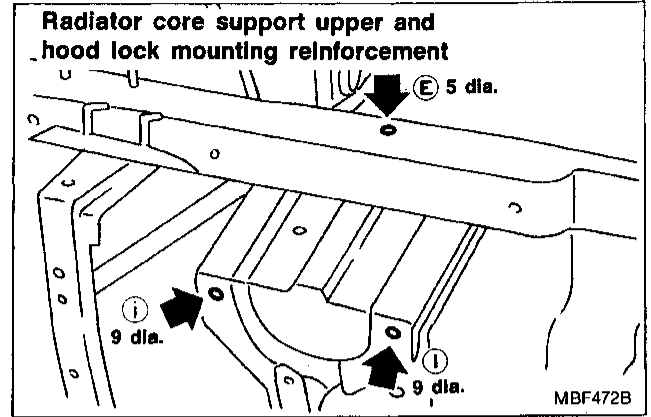
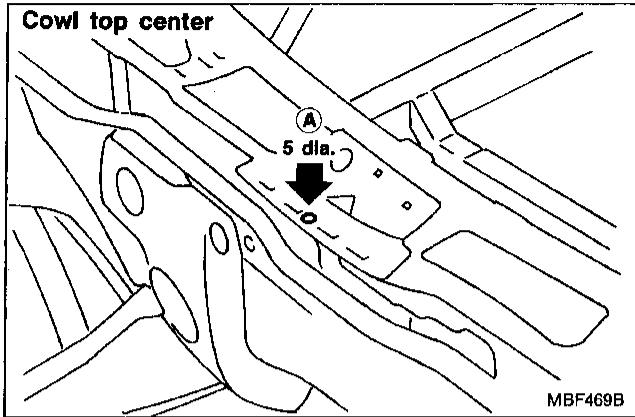

GI

MA

EM

LC

EC

FE

CL

MT

AT

PD

FA

RA

BR

ST

BF

HA

EL

IDX

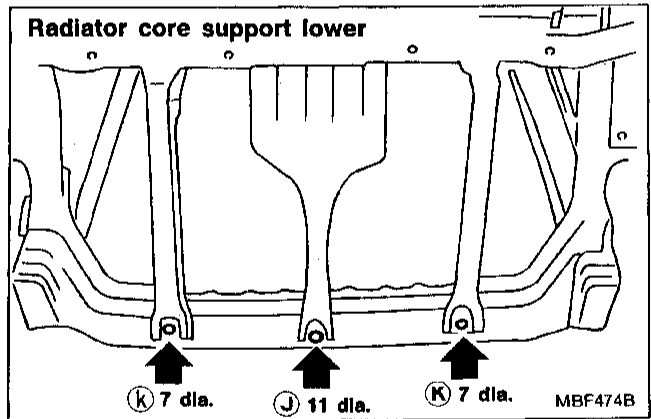
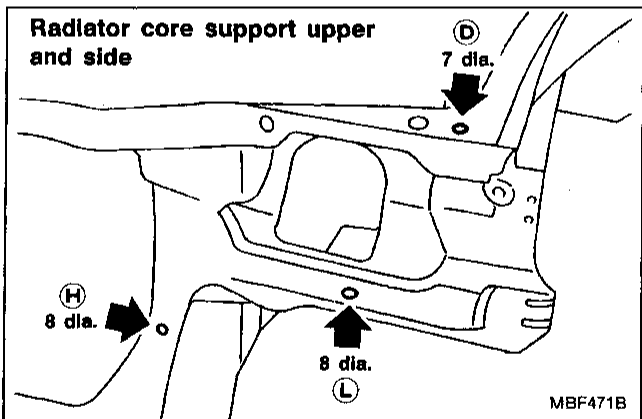
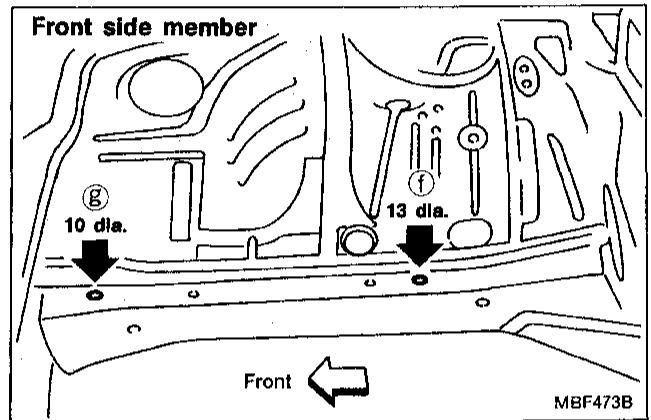
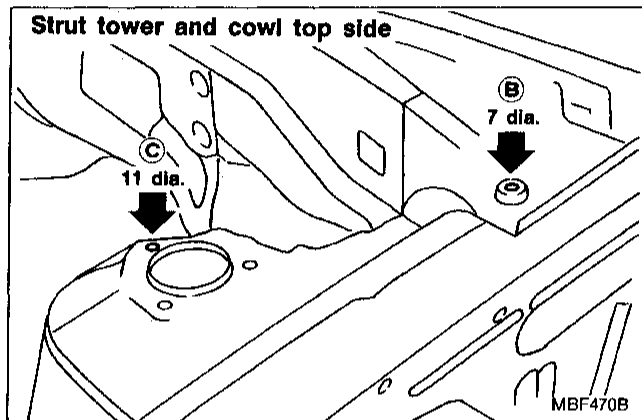

BODY ALIGNMENT

Underbody

MEASUREMENT

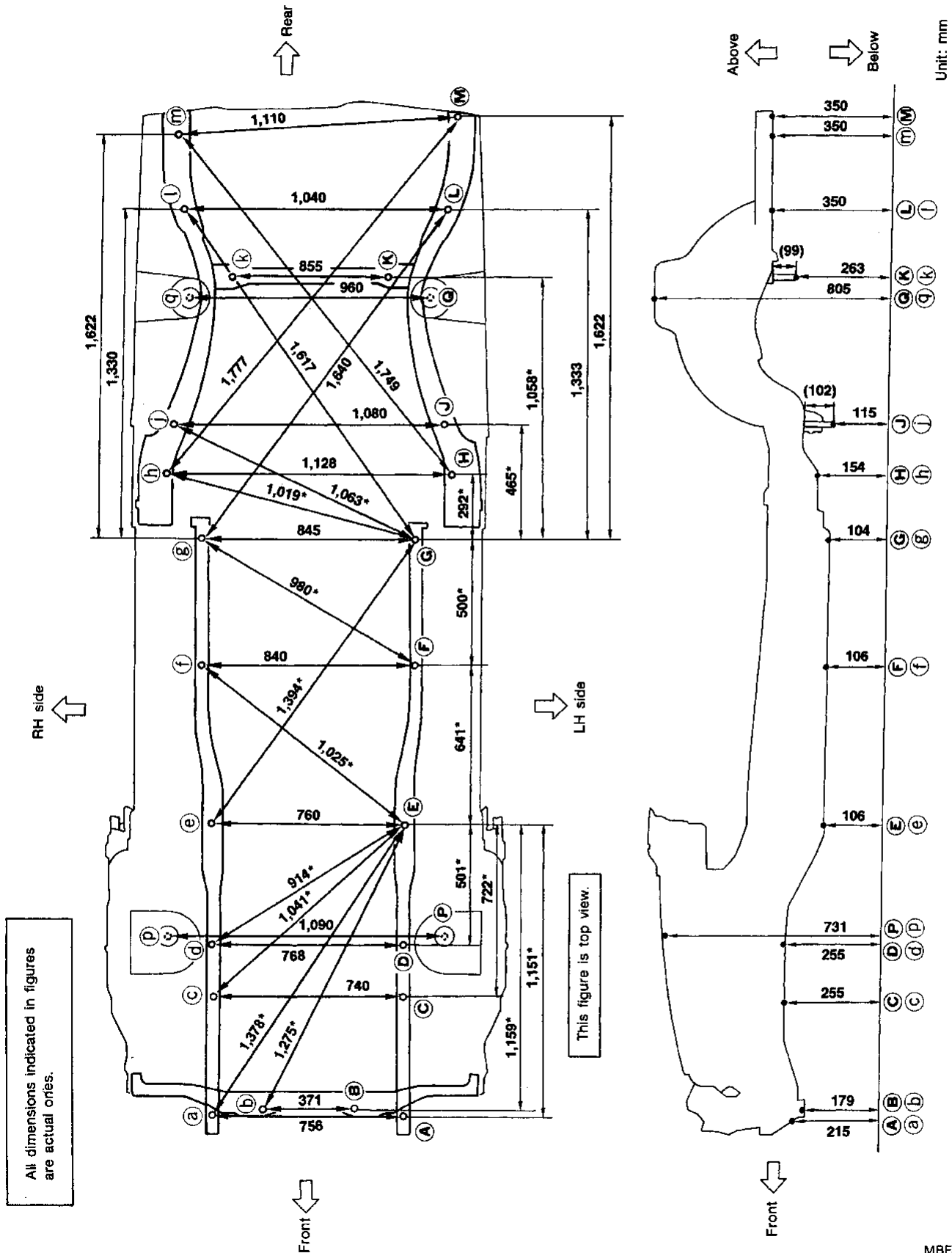

BODY ALIGNMENT

Underbody (Cont'd)

MEASUREMENT POINTS

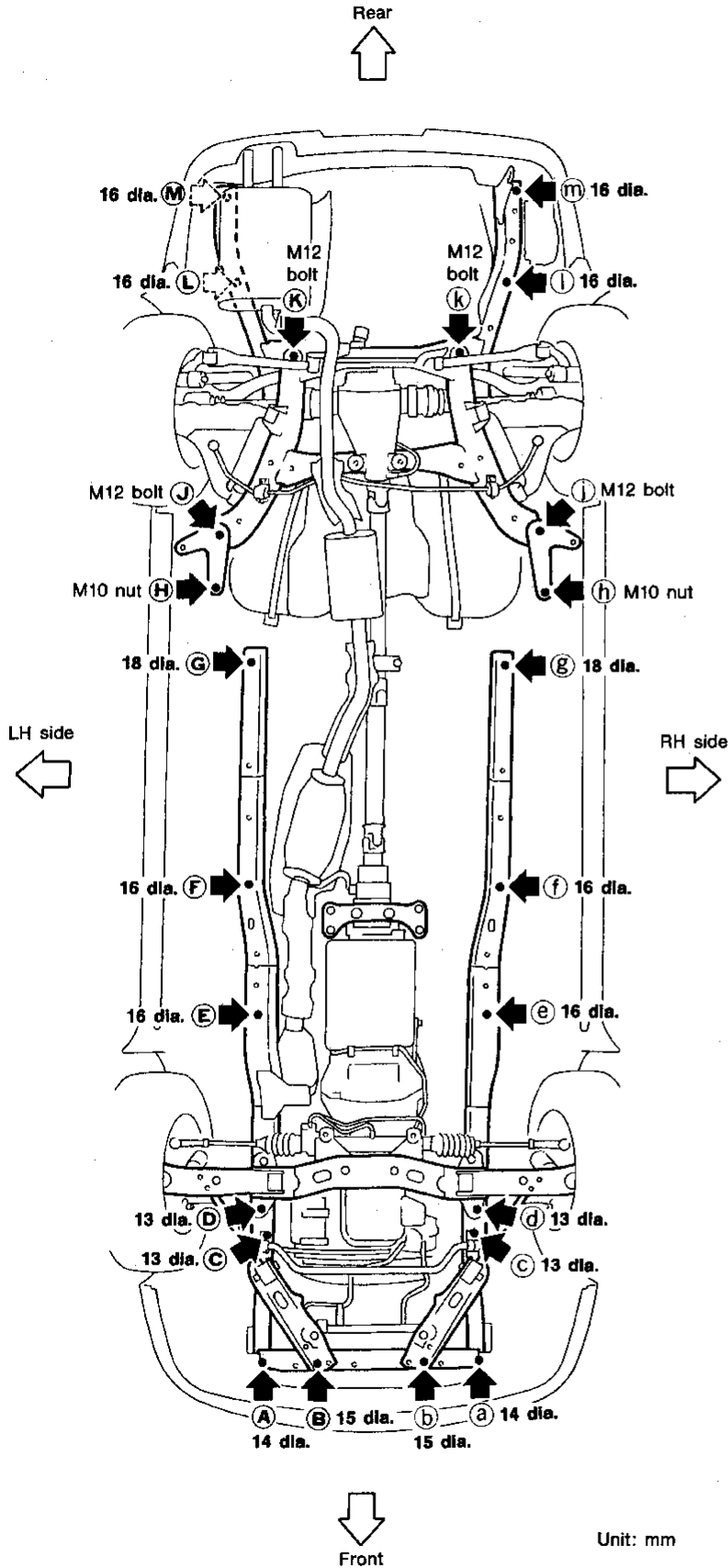

Front coordinates: Rear coordinates:

(A, a) **(G, g)**
 X : 378 X : 422.5
 Y : -635.5 Y : 1,650
 Z : 214.5 Z : 103.9

(B, b) **(H, h)**
 X : 185.3 X : 564
 Y : -630 Y : 1,900
 Z : 179 Z : 154

(C, c) **(J, j)**
 X : 370 X : 540
 Y : -196.5 Y : 2,100
 Z : 254.9 Z : 115.2

(D, d) **(K, k)**
 X : 384.2 X : 308
 Y : 32 Y : 2,690
 Z : 254.9 Z : 262.8

(E, e) **(L)**
 X : 380 X : 540
 Y : 510 Y : 2,955
 Z : 106.2 Z : 350

(F, f) **(I)**
 X : 420 X : 500
 Y : 1,150 Y : 2,955
 Z : 106.2 Z : 350

(M)
 X : 580
 Y : 3,245
 Z : 350

(m)
 X : 530
 Y : 3,250
 Z : 350

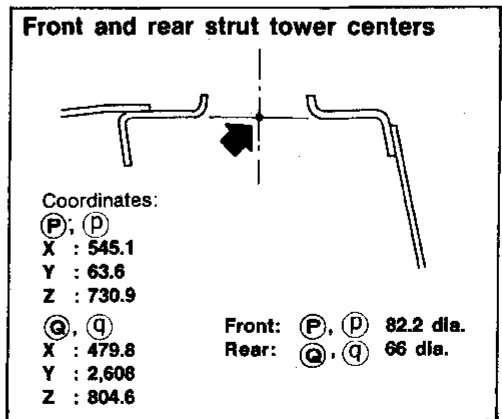

Unit: mm

GI
 MA
 EM
 LC
 EC
 FE
 CL
 MT
 AT
 PD
 FA
 RA
 BR
 ST
 BF
 HA
 EL
 IDX

SUPPLEMENTAL RESTRAINT SYSTEM (SRS)

Precautions for SRS "Air Bag" Service

- Do not use a circuit tester to check SRS circuits.
- Before servicing the SRS, turn ignition switch "OFF", disconnect battery ground cable and wait for at least 10 minutes.
For approximately ten minutes after the cables are removed, it is still possible for the air bag to inflate. Therefore, do not work on any air bag system connectors or wires until at least ten minutes have passed.
- Diagnosis sensor unit must always be installed with their arrow marks "←" facing the front of the vehicle for proper operation. Also check diagnosis sensor unit for cracks, deformities or rust before installation and replace as required.
- The spiral cable must be aligned with the neutral position since its rotations are limited. Do not attempt to turn steering wheel or column after removal of steering gear.
- Handle air bag module carefully. Always place it with the pad side facing upward.
- After removing any SRS parts, discard old bolts and replace with new ones. Conduct self-diagnosis to check entire SRS for proper function.
- After air bag inflates, the front instrument panel assembly should be replaced.

Special Service Tools

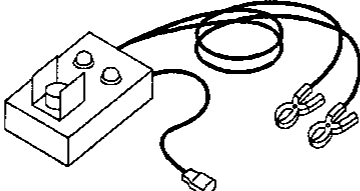
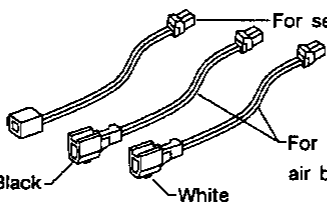
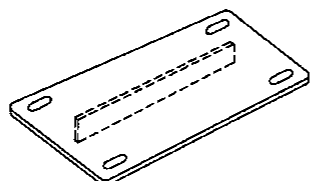
Tool number (Kent-Moore No.) Tool name	Description	
KV99106400 (J38381) Deployment tool		Disposing of air bag module
KV991065S0 (J38381-30) Deployment tool adapters		
KV99105300 (J41246) Passenger air bag bracket		Anchor the passenger air bag module

Commercial Service Tool

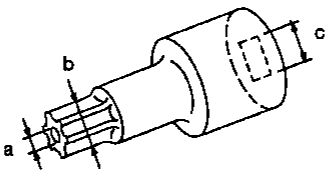
Tool name	Description	
Special torx bit		<p>Use for special bolts [TAMPER RESISTANT TORX (Size T50)]</p> <p>a: 3.5 (0.138) dia. b: 8.5 - 8.6 (0.335 - 0.339) dia. c: approx. 10 (0.39) sq.</p> <p style="text-align: right;">Unit: mm (in)</p>

SUPPLEMENTAL RESTRAINT SYSTEM (SRS)

Description

The air bag deploys if the diagnosis sensor unit activates while the ignition switch is "ON".

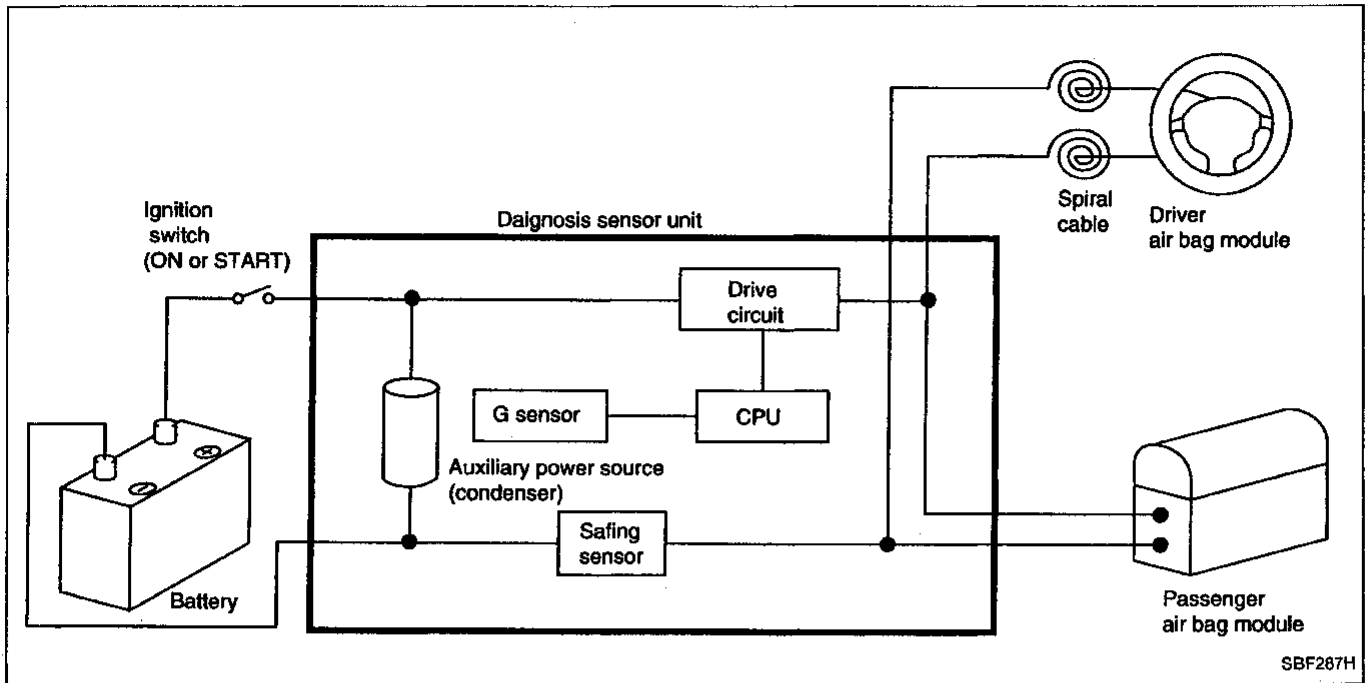

On-board self-diagnosis

The diagnosis sensor unit diagnoses the SRS circuit. After turning ignition key to "ON" or "START" position, "AIR BAG" warning lamp illuminates for about 7 seconds. The "AIR BAG" warning lamp will go out in about 7 seconds, if no malfunction is detected.

GI
MA
EM
LC
EC
FE
CL
MT
AT
PD
FA
RA
BR
ST
BF
HA
EL
IDX

SUPPLEMENTAL RESTRAINT SYSTEM (SRS)

Caution Labels and SRS Component Parts Location

The CAUTION LABELS are important when servicing SRS system in the field. If they are dirty or damaged, replace them with new ones.

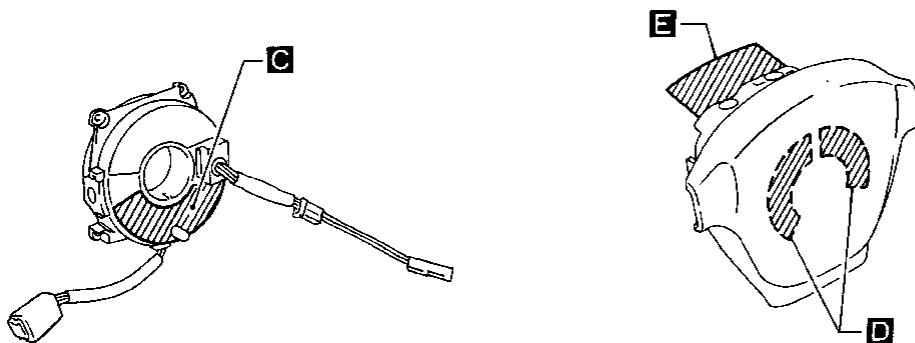
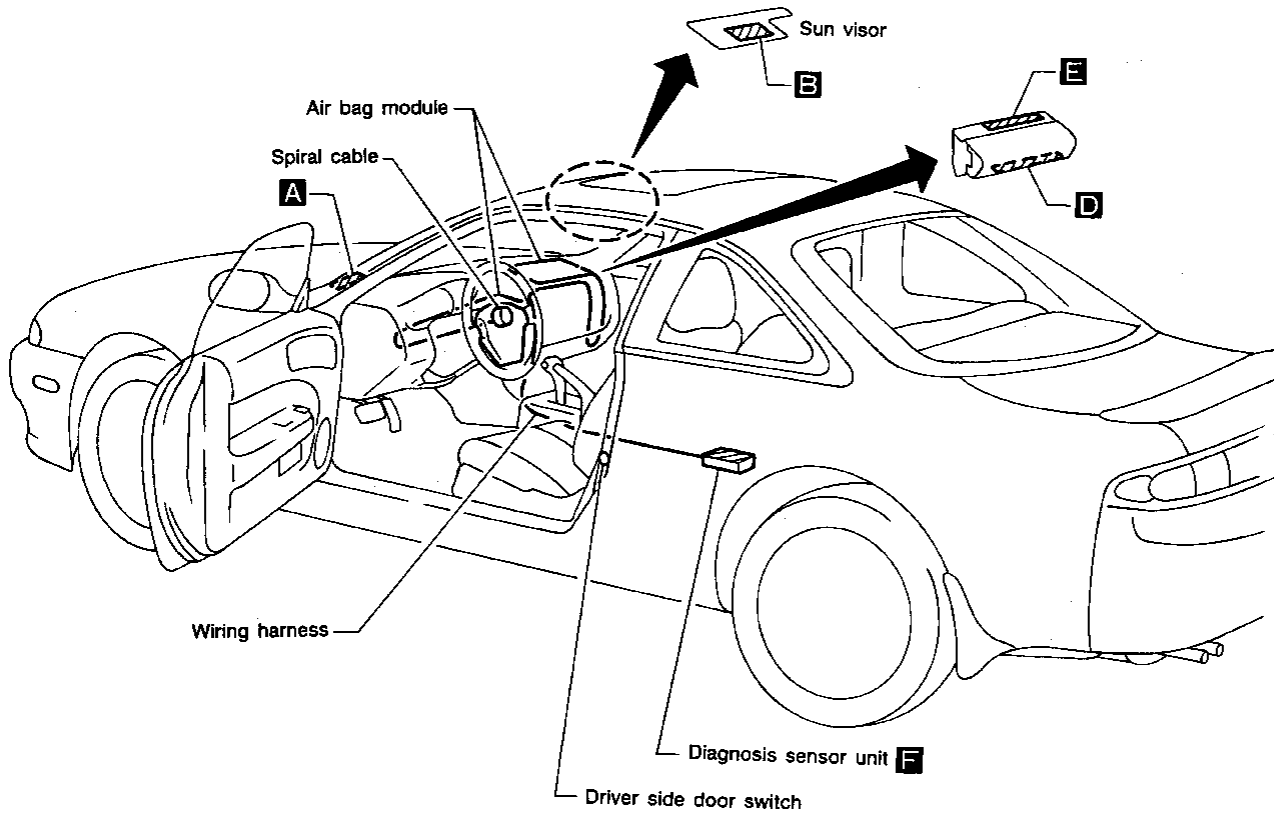

SUPPLEMENTAL RESTRAINT SYSTEM (SRS)

Caution Labels and SRS Component Parts Location (Cont'd)

A

SRS AIRBAG

B

CAUTION

TO AVOID SERIOUS INJURY:

- FOR MAXIMUM SAFETY PROTECTION IN ALL TYPES OF CRASHES, YOU MUST ALWAYS WEAR YOUR SAFETY BELT.
- DO NOT INSTALL REARWARD-FACING CHILD SEATS IN ANY FRONT PASSENGER SEAT POSITION.
- DO NOT SIT OR LEAN UNNECESSARILY CLOSE TO THE AIR BAG.
- DO NOT PLACE ANY OBJECTS OVER THE AIR BAG OR BETWEEN THE AIR BAG AND YOURSELF.
- THE SYSTEM MUST BE INSPECTED 10 YEARS AFTER DATE OF MANUFACTURE SHOWN ON THE CERTIFICATION LABEL, OR IF THE "AIR BAG" LAMP DOES NOT GO ON DURING IGNITION, FLASHES INTERMITTENTLY, OR REMAINS ON.

SEE THE OWNER'S MANUAL FOR FURTHER INFORMATION AND EXPLANATIONS.

C

CAUTION

SRS AIRBAG

- PLEASE READ THE SERVICE MANUAL BEFORE STEERING WHEEL IS REMOVED.
- ATTENTION: BEFORE ASSEMBLY
 - ALIGN FRONT WHEELS STRAIGHT AHEAD.
 - TURN LEFT 2.5 REVOLUTIONS FROM THE RIGHT END POSITION.
 - ALIGN THE TWO MARKS (X).
- NO SERVICEABLE PARTS INSIDE. DO NOT DISASSEMBLE OR TAMPER WITH.

D

DANGER

- CONTENTS ARE POISONOUS AND EXTREMELY FLAMMABLE.
- DO NOT DISMANTLE, INCINERATE OR BRING INTO CONTACT WITH ELECTRICITY OR STORE AT TEMPERATURES EXCEEDING 200°F.

E

WARNING

SRS AIRBAG

- THIS AIRBAG MODULE CAN NOT BE REPAIRED. SEE SERVICE MANUAL FOR INSTRUCTIONS. (ON DIAGNOSIS AND REPLACEMENT.)
- DO NOT DIAGNOSE USING ELECTRICALLY POWERED TEST EQUIPMENT OR PROBING DEVICES.
- TAMPERING OR MISHANDLING CAN RESULT IN PERSONAL INJURY.
- STORE THE REMOVED AIRBAG MODULE WITH THE PAD OR COVER SURFACE UP. (REFER TO SERVICE MANUAL FOR SPECIAL HANDLING OR STORAGE.)

F

WARNING SRS AIRBAG

- NO SERVICEABLE PARTS INSIDE.
- DO NOT DISASSEMBLE OR TAMPER.
- DO NOT DROP; KEEP DRY.
- WHILE REMOVED, STORE IN A CLEAN AND DRY AREA.
- IF WET CONDITION OCCURS, THIS UNIT MUST BE SERVICED.
- DISMANTLING AND INSTALLATION SHOULD ONLY BE PERFORMED BY TRAINED PERSONNEL.

GI

MA

EM

LC

EC

FE

CL

MT

AT

PD

FA

RA

BR

ST

BF

HA

EL

IDX

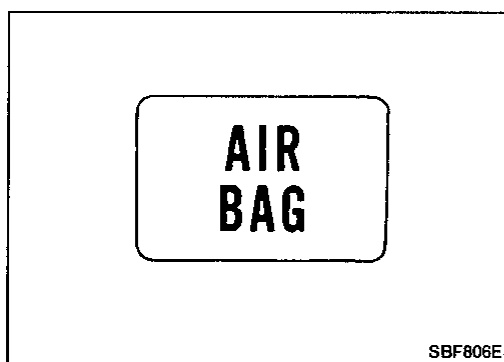

Maintenance Items

1. Check "AIR BAG" warning lamp
After turning ignition key to "ON" or "START" position, "AIR BAG" warning lamp illuminates. The "AIR BAG" warning lamp will go out in about 7 seconds if no malfunction is detected.
When a warning lamp flashes, check and correct cause of the problem.
2. Visually check SRS components
 - (1) Diagnosis sensor unit — Airbag
 - Check case and bracket for dents, cracks or deformities.
 - Check connectors for damage, and terminals for deformities.
 - (2) Main harness and instrument harness
 - Check connectors for poor connections.
 - Check harnesses for binds, connectors for damage, and terminals deformities.
 - (3) Spiral cable
 - Visually check lock (engagement) pins and combination switch for damage.
 - Check connectors, flat cable and protective tape for damage.
 - Check steering wheel for noise, binds or difficult operation.
 - (4) Steering wheel
 - Check harness (built into steering wheel) and connectors for damage, and terminals for deformities.
 - Install air bag module to check fit or alignment with steering wheel.
 - Check steering wheel for excessive free play.
 - (5) Air bag module
 - Remove air bag module from steering wheel.
Check harness cover and connectors for damage, terminals for deformities, and harness for binds.
 - Install air bag module to steering wheel to check fit or alignment with the wheel.

CAUTION:

Replace previously used screws with new ones.

Removal and Installation — Diagnosis Sensor Unit

CAUTION:

- Before servicing SRS, turn the Ignition switch off, disconnect battery ground cable and wait for at least 10 minutes.
- The special bolts are coated with bonding agent. Discard old ones after removal; replace with new ones.
- Check diagnosis sensor unit for proper installation.
- Check diagnosis sensor unit to ensure they are free of deformities, dents, cracks or rust. If they show any visible signs of damage, replace them with new ones.
- Check diagnosis sensor unit brackets to ensure they are free of deformities or rust.

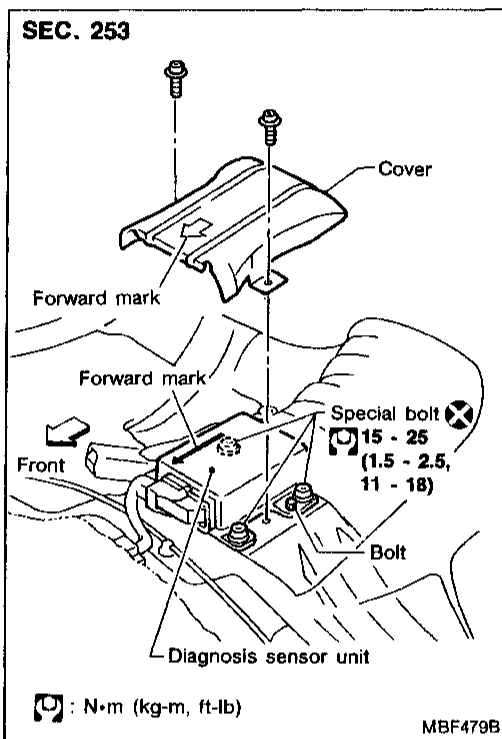

1. Disconnect driver and passenger air bag module connectors.
2. Remove rear seat assembly. Refer to "Rear Seat" (BF-62).
3. Remove cover.
4. Disconnect diagnosis sensor unit connector.
5. Remove bolt and also remove special bolts using the torx bit, from diagnosis sensor unit.
Then remove the diagnosis sensor unit.

NOTE:

To install, reverse the removal procedure sequence.

GI

MA

EM

LC

EC

FE

CL

MT

AT

PD

FA

RA

BR

ST

BF

HA

EL

IDX

SUPPLEMENTAL RESTRAINT SYSTEM (SRS)

Removal — Air Bag Module and Spiral Cable

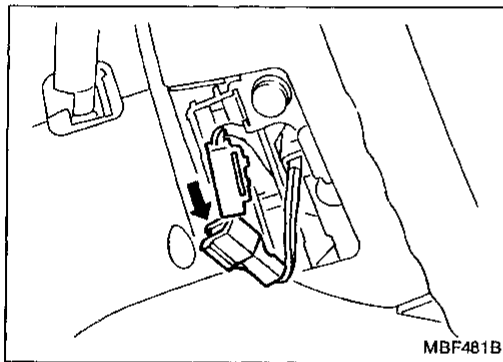
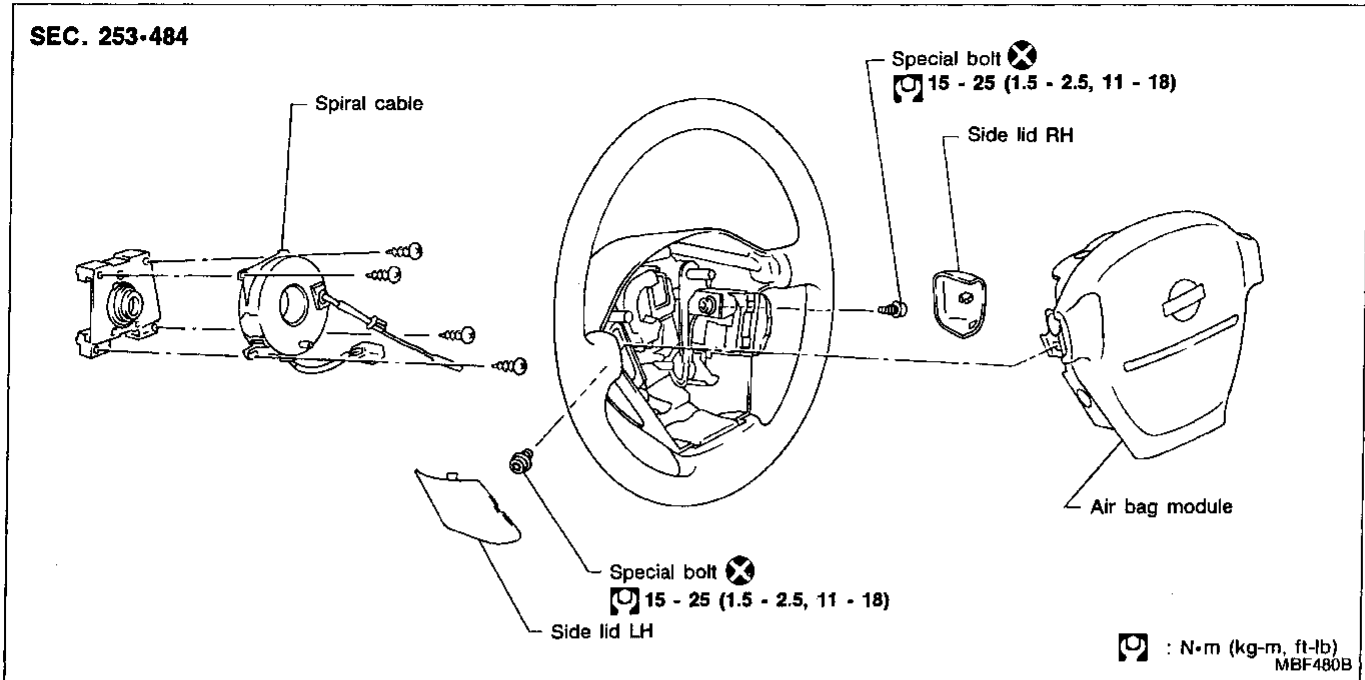

CAUTION:

Before servicing SRS, turn the ignition switch off, disconnect battery ground cable and wait for at least 10 minutes.

1. Remove side lid LH from steering wheel, and disconnect air bag module connector.

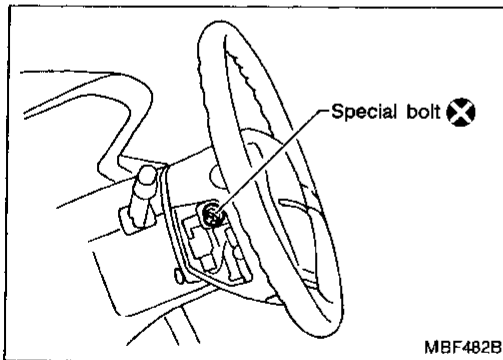

2. Remove side lid. Using the TAMPER RESISTANT TORX (Size T50), remove left and right special bolts. Air bag module can then be removed.

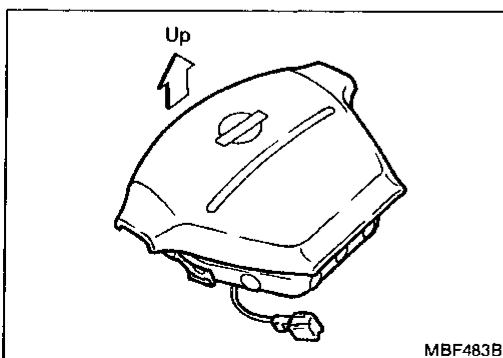

CAUTION:

- Always place air bag module with pad side facing upward.
- Do not attempt to disassemble air bag module.
- The special bolts are coated with bonding agent. Discard old ones after removal; replace with new ones.

SUPPLEMENTAL RESTRAINT SYSTEM (SRS)

Removal — Air Bag Module and Spiral Cable (Cont'd)

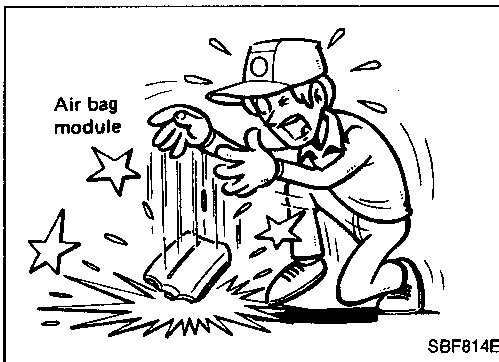

- Do not drop or impact air bag module. If any portion is deformed or cracked, replace the module.
- Do not expose the air bag module to temperatures exceeding 93°C (199°F).
- Do not allow oil, grease or water to come in contact with the air bag module.

GI
MA
EM

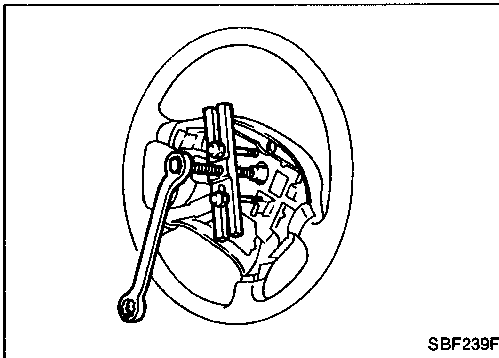

3. Set steering wheel in the neutral position.
4. Disconnect horn connector and remove nuts.
5. Using steering wheel puller, remove steering wheel. Be careful not to over-tighten puller bolt on steering wheel.
6. Remove steering column cover.
7. Disconnect connector and remove the four screws. The spiral cable can then be removed.

LC
EC
FE

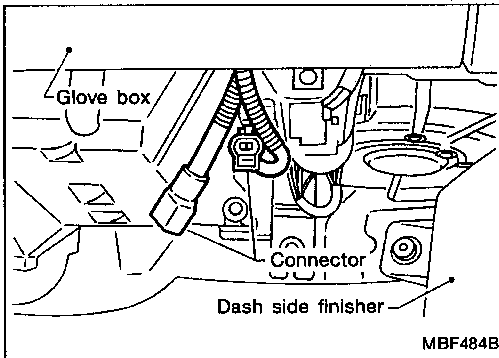

Removal — Front Passenger Air Bag Module

CAUTION:

Before servicing SRS, turn the ignition switch off, disconnect battery ground cable and wait for at least 10 minutes.

1. Remove connector bracket from air bag module and disconnect inflator connector from body harness air bag connector.
2. Remove instrument panel.
3. Remove the special bolts from left and right sides of front passenger air bag module. Then remove the air bag module from the steering member.
 - Air bag module is heavy and should be supported using both hands during removal.

MT
AT
PD

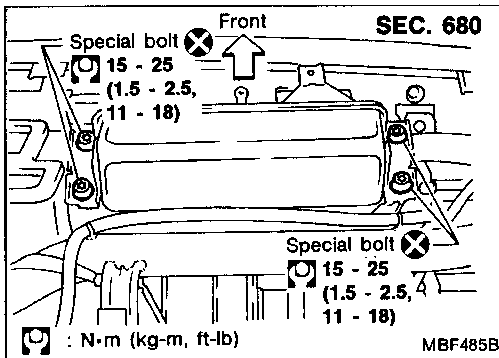

FA
RA
BR

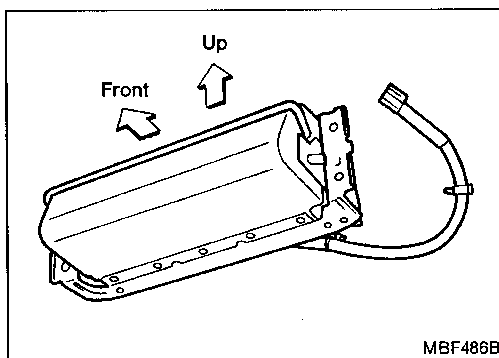

CAUTION:

- Always place air bag module with pad side facing upward.
- Do not attempt to disassemble air bag module.
- The special bolts are coated with bonding agent. Discard old ones after removal; replace with new ones.

ST
BF
HA

EL
IDX

SUPPLEMENTAL RESTRAINT SYSTEM (SRS)

Removal — Front Passenger Air Bag Module (Cont'd)

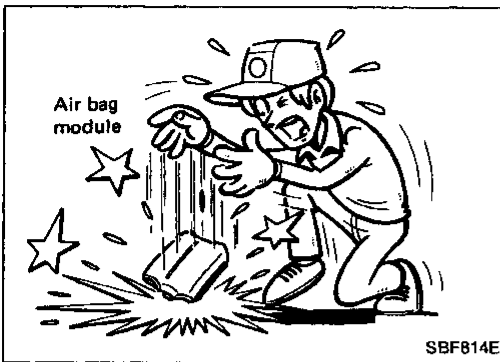

- Do not drop or impact air bag module. If any portion is deformed or cracked, replace the module.
- Do not expose the air bag module to temperatures exceeding 93°C (199°F).
- Do not allow oil, grease or water to come in contact with the air bag module.

SEC. 253

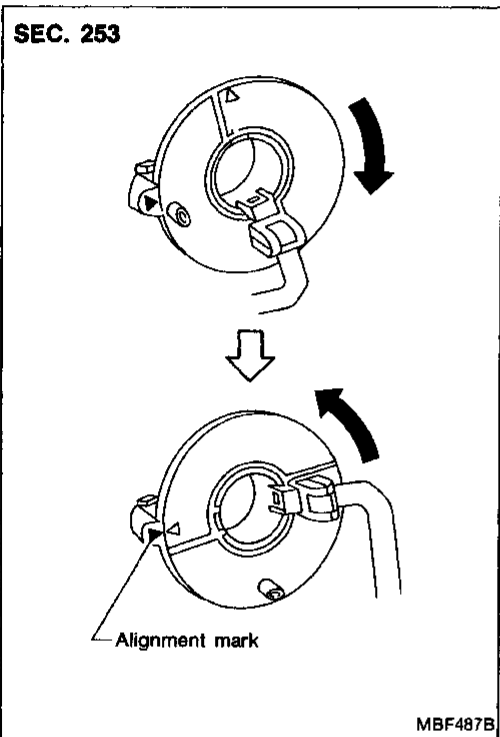

Installation — Air Bag Module and Spiral Cable

1. Set the front wheels in the straight-ahead position.
2. Make sure that the spiral cable is in the neutral position. The neutral position is detected by turning left 2.5 revolutions from the right end position. Align the two marks (X).

CAUTION:

The spiral cable may snap due to steering operation if the cable is installed in an improper position.

Also, with the steering linkage disconnected, the cable may snap by turning the steering wheel beyond the limited number of turns. (The spiral cable can be turned up to 2.5 turns from the neutral position to both the right and left.)

3. Connect spiral cable connector and tighten with screws. Install steering column cover.

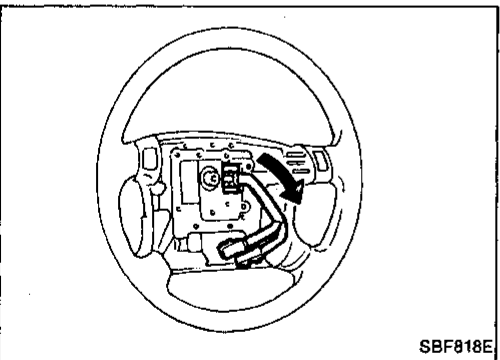

4. Install steering wheel setting spiral cable pin guides, and pull spiral cable through.
5. Connect horn connector and engage spiral cable with pawls in steering wheel.
6. Tighten nuts.

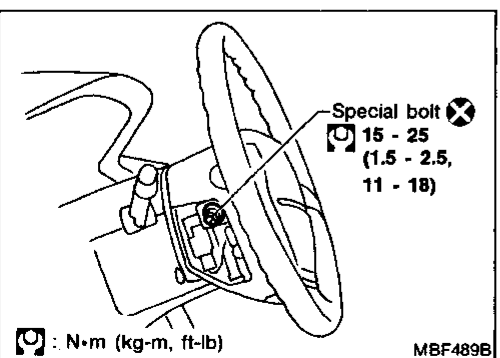

7. Position air bag module and tighten with new special bolts.
8. Connect air bag module connector.
9. Install all lids.
10. Conduct self-diagnosis to ensure entire SRS operates properly. (Use CONSULT or warning lamp check.)

SUPPLEMENTAL RESTRAINT SYSTEM (SRS)

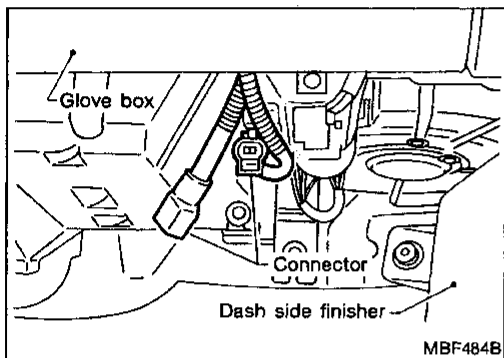
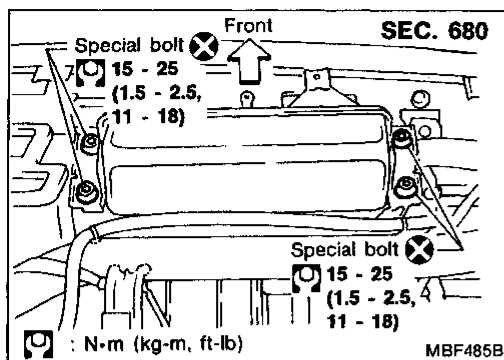

Installation — Front Passenger Air Bag Module

1. Install front passenger air bag module on steering member.
 - Ensure harness is not caught between rear of air bag module and steering member.
2. Install instrument panel.
3. Connect air bag module connector to body harness connector.
4. Install air bag module connector on connector bracket.
5. Install connector bracket on air bag module.

Disposal of Air Bag Module

- Before disposing of air bag module or vehicle equipped with such a system, deploy the system. If such a system has already been deployed due to an accident, dispose of as indicated in the section "DISPOSING OF AIR BAG MODULE".
- Do not dispose of the air bag module un-deployed.
- When deploying the air bag module, always use the Special Service Tool; Deployment tool KV99106400 (Kent-Moore No. J38381).
- When deploying the air bag module, stand at least 5 m (16 ft) away from the air bag module.
- Due to heat, leave air bag module unattended for more than 30 minutes after deployment.
- Be sure to wear gloves when handling a deployed air bag module.
- Never apply water to a deployed air bag module.
- Wash your hands clean after finishing work.

CHECKING DEPLOYMENT TOOL

Connecting to battery

- Place the vehicle outdoors in an open space of at least 6 m (20 ft) on all sides.
- Use a voltmeter to make sure the vehicle battery is fully charged.

CAUTION:

The battery must show voltage of 9.6V or more.

Remove the battery from the vehicle and place it on dry wood blocks approximately 5 m (16 ft) away from the vehicle.

- Wait 10 to 12 minutes after the vehicle battery is disconnected before proceeding.
- Connect red clip of deployment tool to battery positive terminal and black clip to negative terminal.

CAUTION:

Make sure the polarity is correct. The right side lamp in the tool, marked "deployment tool power", should glow with a green light. If the right side lamp glows red, reverse the connections to the battery.

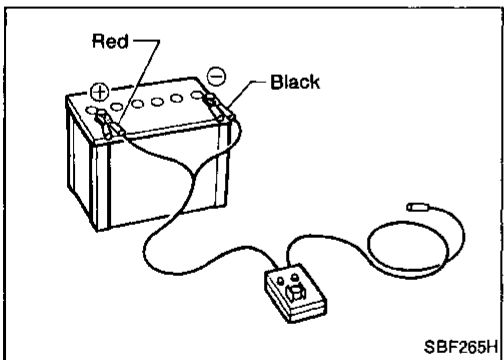

GI

MA

EM

LC

EC

FE

CL

MT

AT

PD

FA

RA

BR

ST

BF

HA

EL

IDX

SUPPLEMENTAL RESTRAINT SYSTEM (SRS)

Disposal of Air Bag Module (Cont'd)

Deployment tool check

Press the deployment tool switch to the "ON" position. The left side lamp in the tool, marked "air bag connector voltage" should illuminate. If it does not illuminate, replace the tool.

Air bag deployment tool lamp illumination chart (Battery connected)

Switch operation	Left side lamp, green* "AIR BAG CONNecTOR VOLTAGE"	Right side lamp, green* "DEPLOYMENT TOOL POWER"
OFF	OFF	ON
ON	ON	ON

*: If this lamp glows red, the tool is connected to the battery incorrectly. Reverse the connections and make sure the lamp glows green.

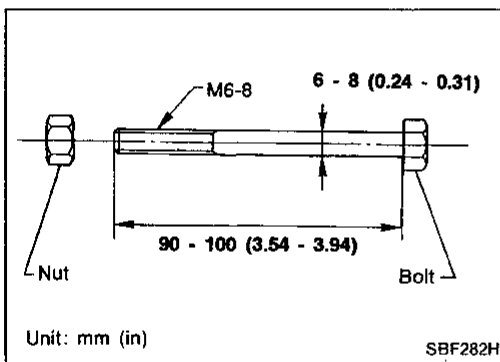
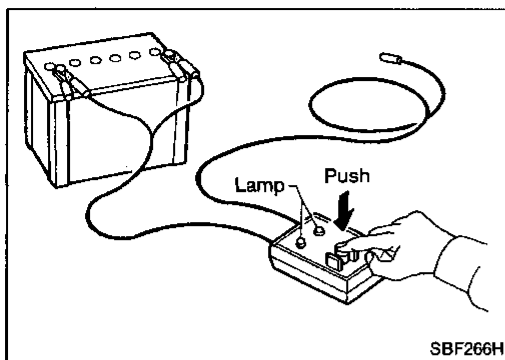

DEPLOYMENT PROCEDURES FOR AIR BAG MODULE AS A UNIT

Deploying air bag module while it is mounted in vehicle may damage vehicle. Deploy air bag module as a unit except when disposing of vehicle.

Anchor air bag module in a vise secured to a firm foundation during deployment.

Deployment of driver's air bag module as a unit

1. Prepare two sets of nuts and bolts (see figure at left). These bolts are required to secure driver's air bag module to the vise.
2. Install one set of nuts and bolts to each side of the air bag module.

CAUTION:

Make sure to install two bolts and nuts on each side.

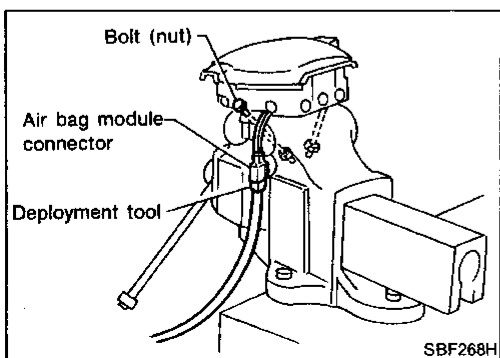
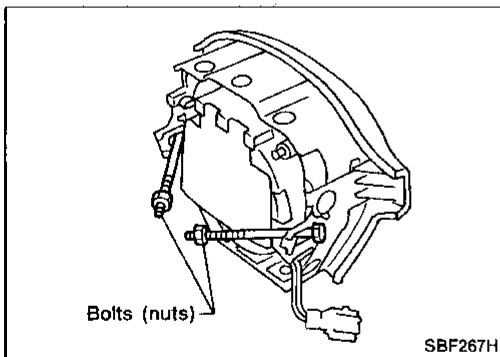

3. Firmly place two nuts (secured to air bag module) in the vise.

CAUTION:

Ensure these two nuts are equally placed in the vise. Never finish the installation with just one nut.

4. Connect deployment tool (SST: KV99106400) to air bag module connector.

SUPPLEMENTAL RESTRAINT SYSTEM (SRS)

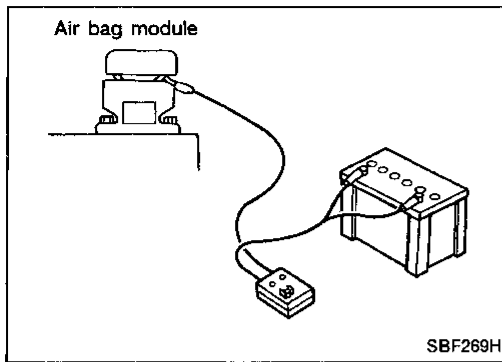

Disposal of Air Bag Module (Cont'd)

5. Connect red clip of deployment tool to battery positive terminal and black clip to negative terminal.
6. The lamp on the right side of the tool, marked "deployment tool power", should glow green, not red.
7. Press the button on the deployment tool. The left side lamp on the tool, marked "air bag connector voltage", will illuminate and the air bag module will deploy.

CAUTION:

When deploying the air bag module, stand at least 5 m (16 ft) away from the air bag module.

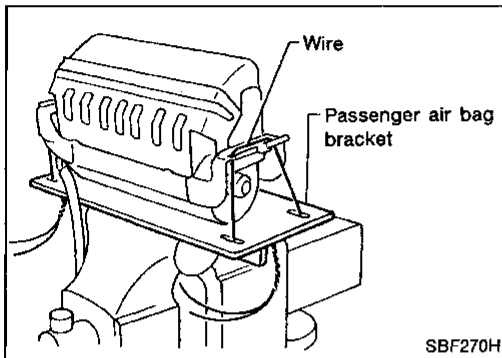

Deployment of passenger air bag module as a unit

1. Using wire, secure air bag module to passenger air bag bracket (SST: KV99105300) at two places.

CAUTION:

Use wire of at least 1 mm (0.04 in) in diameter.

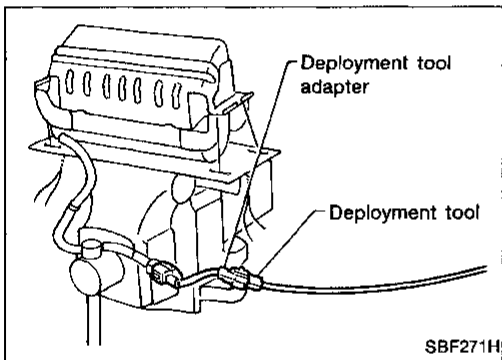

2. Firmly anchor passenger air bag bracket in a vise.
3. Connect deployment tool adapter (SST: KV991065S0) to deployment tool (SST: KV99106400) connector and connector on either side of air bag module.

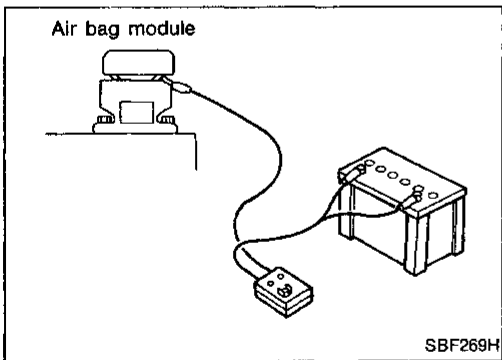

4. Connect red clip of deployment tool to battery positive terminal and black clip to negative terminal.
5. The lamp on the right side of the tool, marked "deployment tool power", should glow green, not red.
6. Press the button on the deployment tool. The left side lamp on the tool, marked "air bag connector voltage", will illuminate and the air bag module will deploy.

CAUTION:

When deploying the air bag module, stand at least 5 m (16 ft) away from the air bag module.

7. Activate the other inflator.

CAUTION:

Always activate one inflator at a time.

GI

MA

EM

LC

EC

FE

CL

MT

AT

PD

FA

RA

BR

ST

BF

HA

EL

IDX

SUPPLEMENTAL RESTRAINT SYSTEM (SRS)

Disposal of Air Bag Module (Cont'd)

DEPLOYMENT OF AIR BAG MODULE WHILE MOUNTED IN VEHICLE

When disposing of vehicles, deploy air bag module while it is mounted in vehicle.

CAUTION:

When deploying air bag module, ensure vehicle is empty.

1. Disconnect the vehicle battery ground cable and wait 10 minutes.
2. Disconnect air bag module connector.
3. Connect deployment tool connector (SST: KV99106400) to air bag module.

For front passenger air bag module, attach deployment tool adapters (SST: KV991065S0) to the tool connector.

4. Connect red clip of deployment tool to battery positive terminal and black clip to negative terminal.
5. The lamp on the right side of the tool, marked "deployment tool power", should glow green, not red.
6. Press the button on the deployment tool. The left side lamp on the tool, marked "air bag connector voltage", will illuminate. Then the air bag module will deploy.

CAUTION:

Activate only one passenger air bag module inflator at a time.

DISPOSING OF AIR BAG MODULE

Deployed air bag module is very hot. Before disposing of air bag module, wait at least 30 minutes. Seal them in a vinyl bag before disposal.

CAUTION:

- **Never apply water to a deployed air bag module.**
- **Be sure to wear gloves when handling a deployed air bag module.**
- **No poisonous gas is produced upon air bag module deployment. However, be careful not to inhale gas since it irritates throat and can cause choking.**
- **Do not attempt to disassemble air bag module.**
- **Air bag module cannot be re-used.**
- **Wash your hands clean after finishing work.**

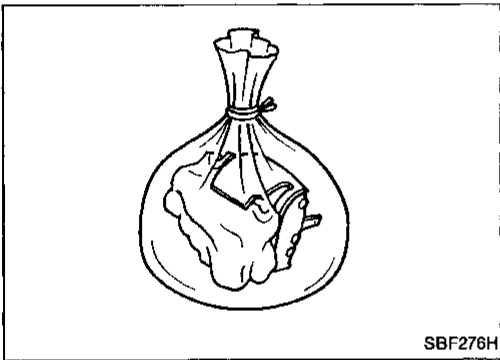
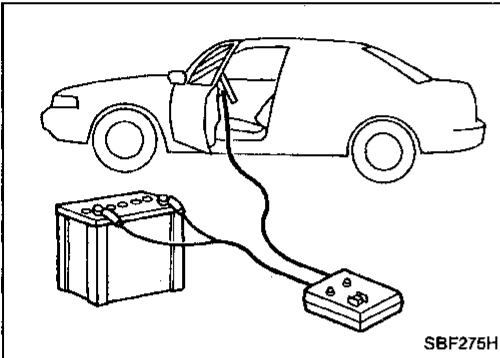
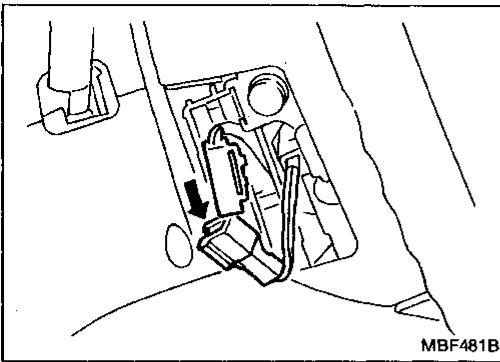

Wiring Diagram — SRS —

BF-SRS-01

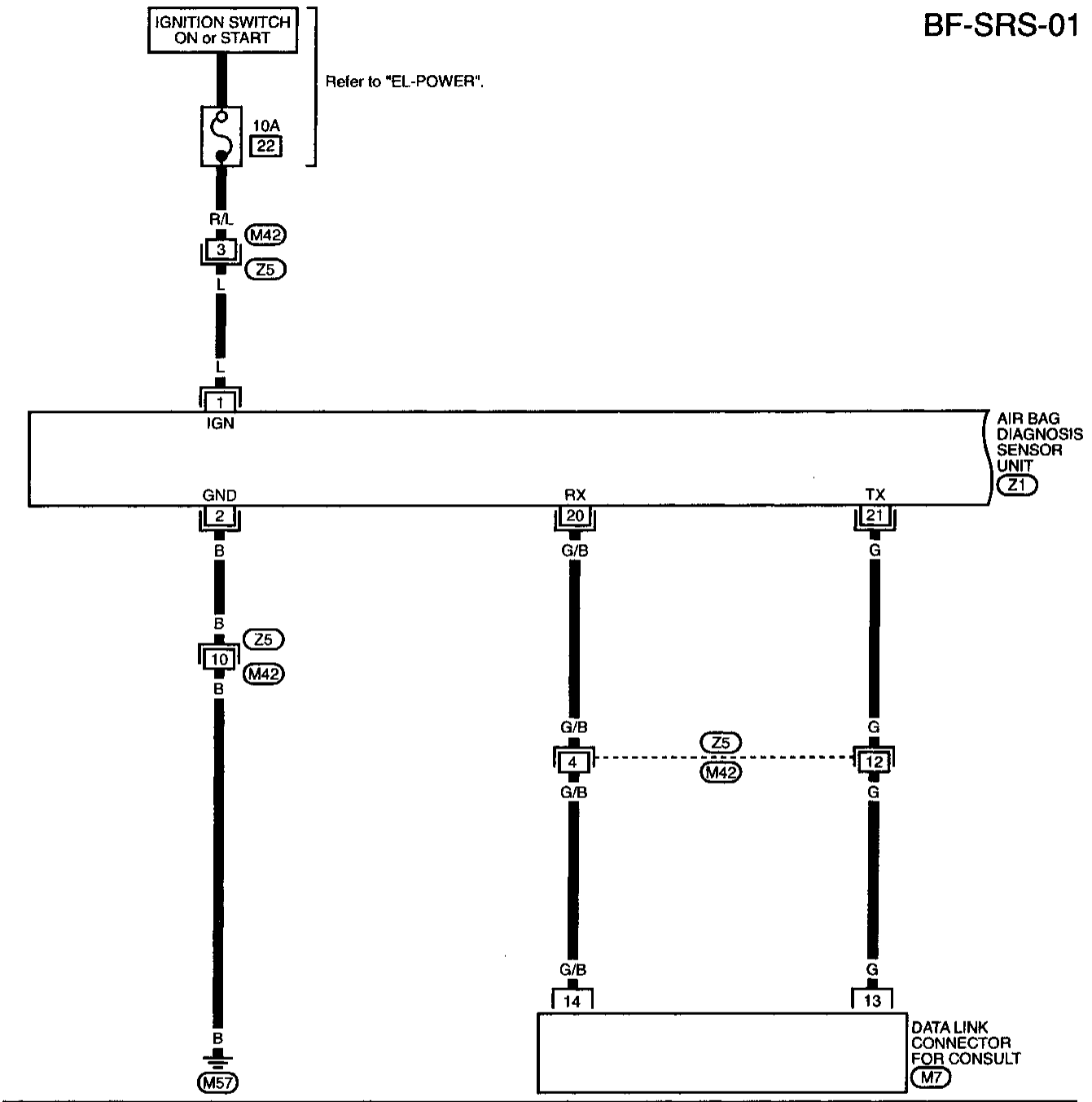

GI
MA
EM
LC
EC
FE
CL
MT
AT
PD
FA
RA
BR
ST
BF



HA
EL
IDX

TROUBLE DIAGNOSES — Supplemental Restraint System (SRS)

Wiring Diagram — SRS — (Cont'd)

BF-SRS-02

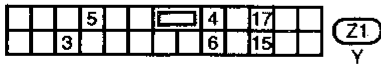
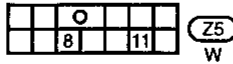
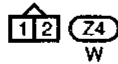
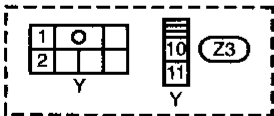
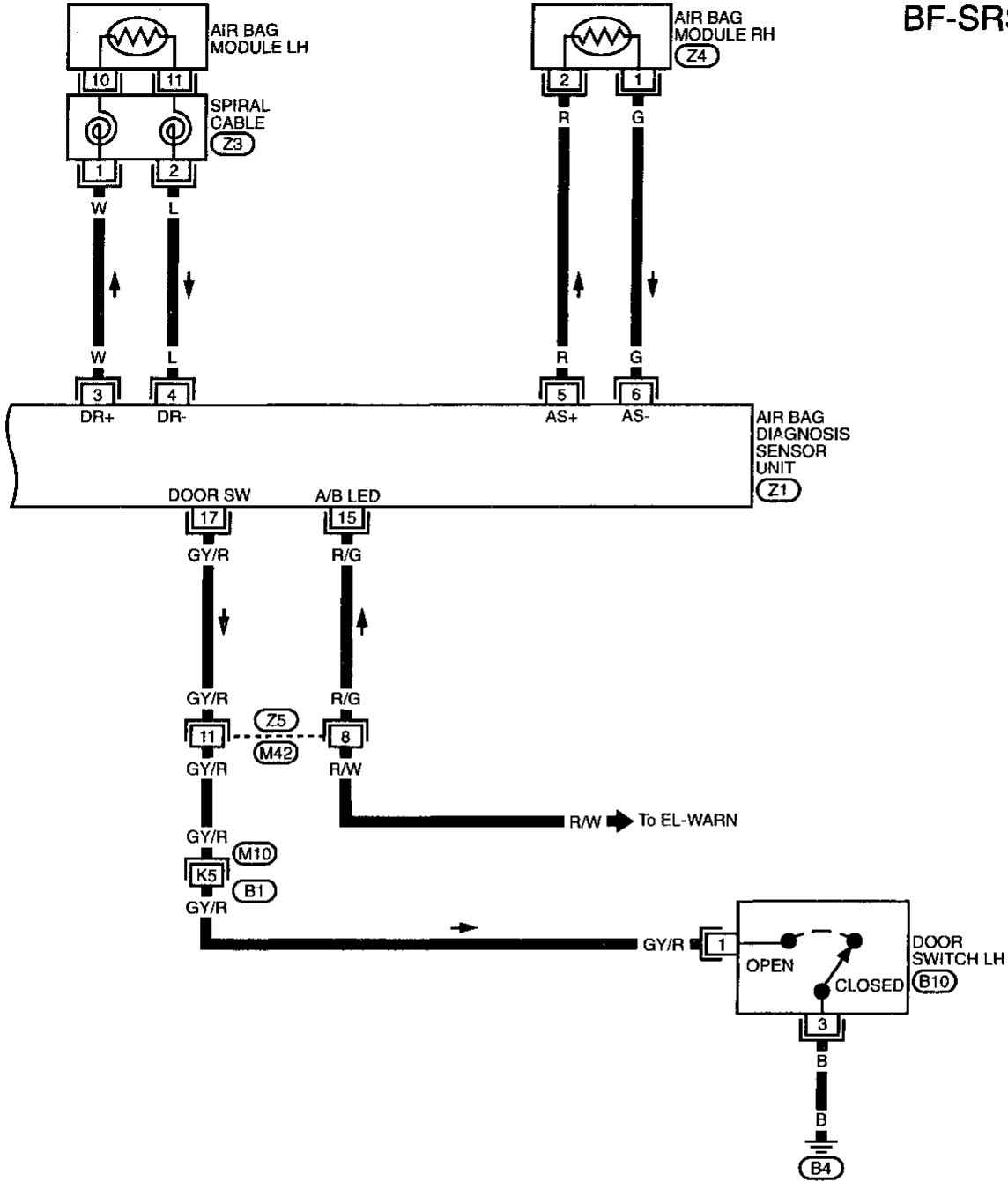

Refer to last page (Foldout page).
(M10), (B1)

Schematic

CAUTION:

- Do not use a circuit tester to check SRS "Air Bag" harness connectors. The wiring harness and connectors have yellow outer insulation for easy identification.
- Do not attempt to repair, splice or modify the SRS "Air Bag" wiring harness. If the harness is damaged, replace it with a new one.
- Keep ground portion clean.

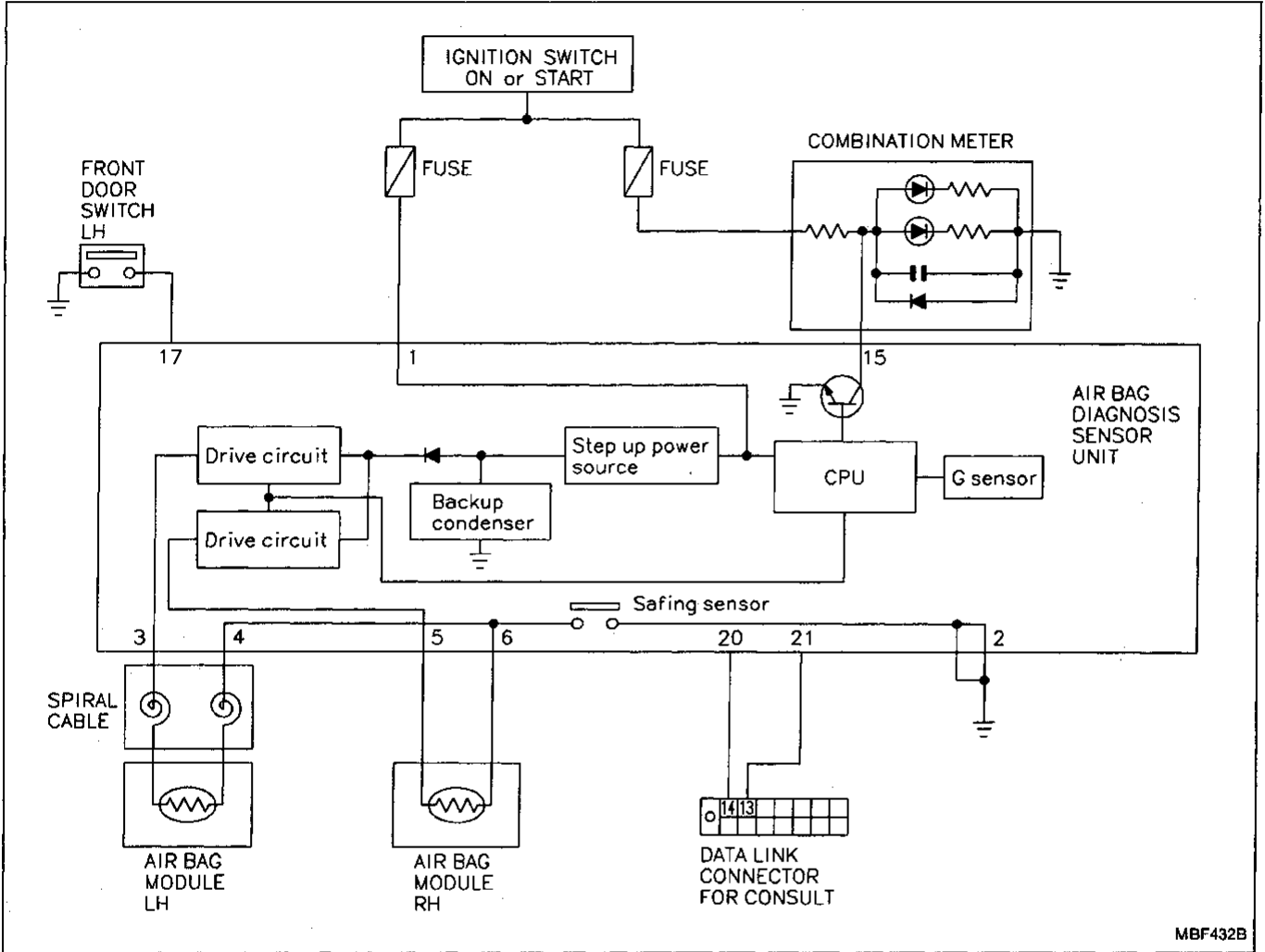

GI
MA
EM
LC
EC
FE
CL
MT
AT
PD
FA
RA
BR
ST

BF

HA
EL
IDX

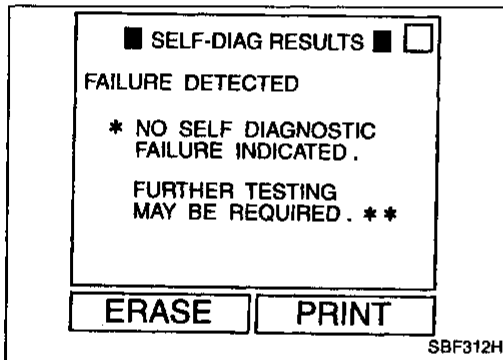
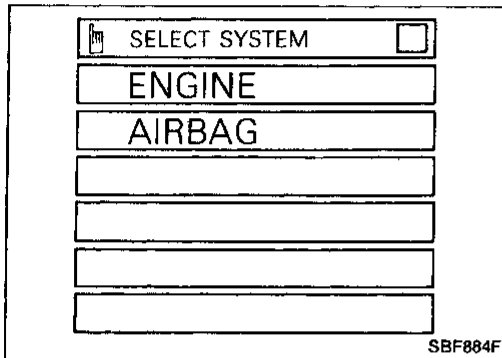
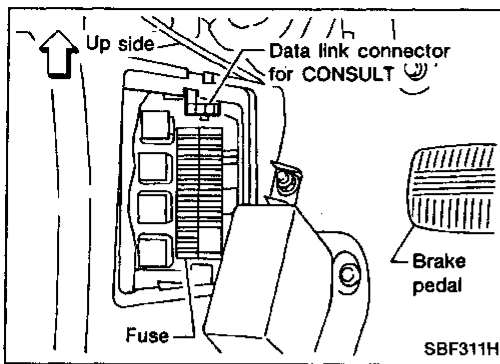

Self-diagnosis

USING CONSULT

Operation procedure

The self-diagnosis results can be read by CONSULT, as follows:

1. Connect "CONSULT" to vehicle harness connector.
- ↓
2. Turn ignition switch to "ON". (When CONSULT is connected, the "AIR BAG" warning lamp will be turned to present diagnosis mode.)
- ↓
3. Touch "START" to operate "CONSULT".
- ↓
4. Touch "AIR BAG" to choose air bag system.
- ↓
5. Touch "SELF DIAG RESULTS" to read self-diagnosis results.
- ↓
6. Problem codes are displayed on "SELF DIAG RESULTS".
- ↓
7. When "PRINT" is pressed, information displayed on "SELF DIAG RESULTS 1 and 2" is printed out.

WARNING:

- While CONSULT is displaying this "SELF-DIAG RESULTS" information, do not disconnect CONSULT from data link connector.
- When finishing diagnosis, make sure to change CONSULT display to SELECT SYSTEM mode by using BACK KEY.

8. After repairing malfunctioning parts, press "ERASE" to clear self-diagnosis results.

- "ERASE" function requires selecting "ERASE", and completing step 9.

9. Push Back Key of CONSULT until SELECT SYSTEM mode appears to make "SELF-DIAGNOSIS" user mode.

- If malfunctioning parts are not completely repaired, "AIR BAG" warning lamp will blink every 0.5 seconds.

10. Push the power off switch.

11. Turn off ignition switch, disconnect CONSULT.

12. Turn ignition switch to "ON".
"AIR BAG" warning lamp should come on for about 7 seconds and then go off.

TROUBLE DIAGNOSES — Supplemental Restraint System (SRS)

Self-diagnosis (Cont'd)

Self-diagnosis results

Diagnostic item	Explanation	Repair order * Recheck SRS at each replacement.	
NO SELF DIAGNOSTIC FAILURE INDICATED.	Normal. The SRS system is in good order.	—	GI
AIRBAG MODULE [OPEN]	The circuit for driver's air bag module is open. (including the spiral cable)	<ol style="list-style-type: none"> 1. Visually check the wiring harness connections. 2. Replace the spiral cable. 3. Replace driver's air bag module. (Before disposing of it, it must be deployed.) 4. Replace the diagnosis sensor unit. 5. Replace the main harness. 	MA
AIRBAG MODULE [VB-SHORT]	The circuit for driver's air bag module is shorted to some power supply circuit. (including the spiral cable)		EM
AIRBAG MODULE [GND-SHORT]	The circuit for driver's air bag module is shorted to ground. (including the spiral cable)		LC
AIRBAG MODULE [SHORT]	The circuits for driver's air bag module are shorted to each other.		EC
ASSIST A/B MODULE [OPEN]	The circuit for front passenger air bag module is open.	<ol style="list-style-type: none"> 1. Visually check the wiring harness connections. 2. Replace front passenger air bag module. (Before disposing of it, it must be deployed.) 3. Replace the diagnosis sensor unit. 4. Replace the main harness. 	FE
ASSIST A/B MODULE [VB-SHORT]	The circuit for front passenger air bag module is shorted to some power supply circuit.		CL
ASSIST A/B MODULE [GND-SHORT]	The circuit for front passenger air bag module is shorted to ground.		MT
ASSIST A/B MODULE [SHORT]	The circuits for front passenger air bag module are shorted to each other.		AT
CONTROL UNIT	The diagnosis sensor unit is out of order.	<ol style="list-style-type: none"> 1. Visually check the wiring harness connections. 2. Replace the diagnosis sensor unit. 3. Replace the main harness. 	PD
INDEFINITE FAILURES [AIR BAG]	A problem which cannot be specified occurs because more than two parts are out of order.	<ol style="list-style-type: none"> 1. Visually check the wiring harness connections. 2. Replace the diagnosis sensor unit. 3. Replace spiral cable and air bag modules. 4. Replace the main harness. 	FA

BR

ST

BF

HA

EL

IDX

TROUBLE DIAGNOSES — Supplemental Restraint System (SRS)

Self-diagnosis (Cont'd)

USING THE WARNING LAMP

Self-diagnosis results can be also read by using the "AIR BAG" warning lamp for SRS system.

The "Air bag" warning lamp operates as shown below:

WARNING:

When the "AIR BAG" warning lamp is flashing, compare the flash time to the chart below.

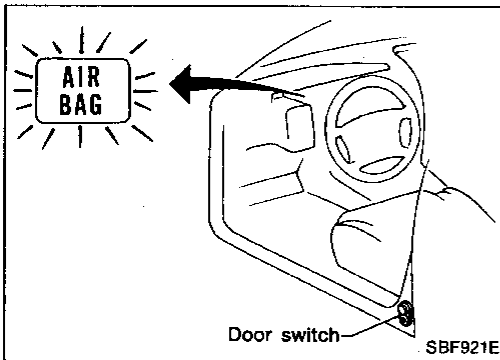

How to alternate self-diagnosis

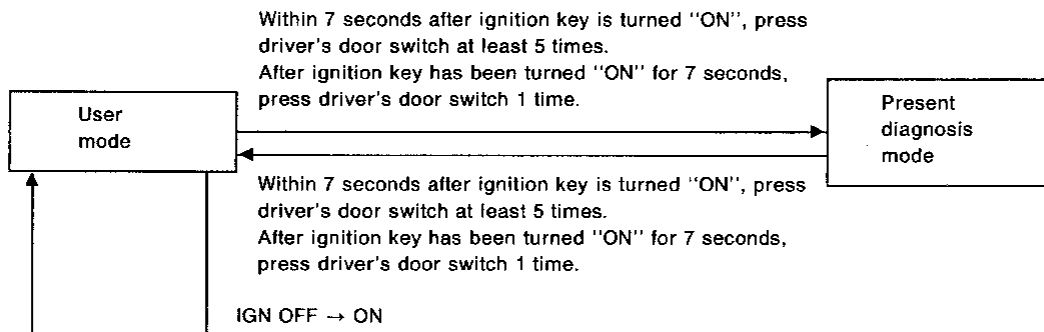

Problem codes are displayed in present diagnosis mode (self-diagnosis results).

Warning lamp indication

After the malfunctioning parts have been repaired, return the system to the user mode. This will clear the present diagnosis mode information displayed as self-diagnosis results.

- After repairing malfunctioning part, attempt to clear self-diagnosis results from memory.
- If a malfunctioning part is not completely repaired, information stored in memory will not be cleared.

User mode	
<p>① Normal (OFF)</p> <p>IGN ON</p> <p>Light check</p> <p>ON</p> <p>OFF</p> <p>7 sec.</p> <p>SBF298H</p>	No problem.
<p>② Malfunction (blinking)</p> <p>ON</p> <p>OFF</p> <p>0.5 sec.</p> <p>0.5 sec.</p> <p>SBF299HA</p>	The system has problem. Perform self-diagnosis with "Present diagnosis mode".
<p>③ Air bag is deployed or diagnosis sensor unit is malfunctioning and continuously sends an "ON" signal.</p> <p>ON</p> <p>OFF</p> <p>SBF284HA</p>	The system needs to be repaired. (Refer to page BF-100.)

TROUBLE DIAGNOSES — Supplemental Restraint System (SRS)

Self-diagnosis (Cont'd)

Present diagnosis mode (Self-diagnosis result)

- Indicate malfunctioning part — The system needs to be repaired.

ⓑ Start signal; Start signal identifies display modes.

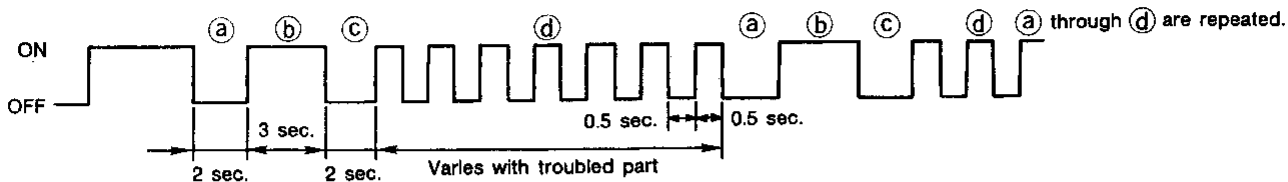

SBF300H

- No malfunctioning (or intermittent trouble/repair completion)

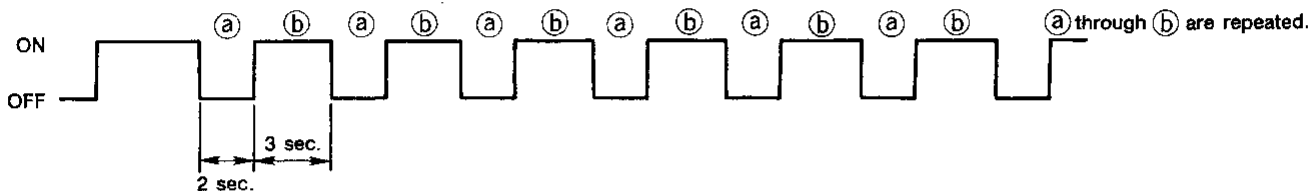

SBF285H

WARNING:

- After the malfunctioning parts have been repaired, return the system to "User mode".

Self-diagnosis results in present mode can be identified by number of flashes ⓓ. Refer to Table on next page for troubled parts.

GI

MA

EM

LC

EC

FE

CL

MT

AT

PD

FA

RA

BR

ST

BF

HA

EL

IDX

TROUBLE DIAGNOSES — Supplemental Restraint System (SRS)

Self-diagnosis (Cont'd)

Warning lamp flashing times and repair

Warning lamp	Flash code ① (# of flashes)	Explanation	Repair order * Recheck SRS at each replacement.
"AIR BAG" warning lamp	0	Normal. The SRS "Air Bag" is in good order.	—
	2	The circuit for the driver's air bag module is out of order.	<ol style="list-style-type: none"> 1. Visually check the wiring harness connections. 2. Replace the spiral cable. 3. Replace the driver's air bag module. (Before disposing of it, it must be deployed.) 4. Replace the diagnosis sensor unit. 5. Replace the main harness.
	7	The diagnosis sensor unit is out of order.	<ol style="list-style-type: none"> 1. Visually check the wiring harness connections. 2. Replace the diagnosis sensor unit. 3. Replace the main harness.
	8	The circuit for the front passenger air bag module is out of order.	<ol style="list-style-type: none"> 1. Visually check the wiring harness connections. 2. Replace the front passenger air bag module. (Before disposing of it, it must be deployed.) 3. Replace the diagnosis sensor unit. 4. Replace the main harness.
	9	More than two parts groups are out of order.	<ol style="list-style-type: none"> 1. Visually check the wiring harness connections. 2. Replace the diagnosis sensor unit. 3. Replace all sensors, spiral cable and air bag module. 4. Replace the main harness.

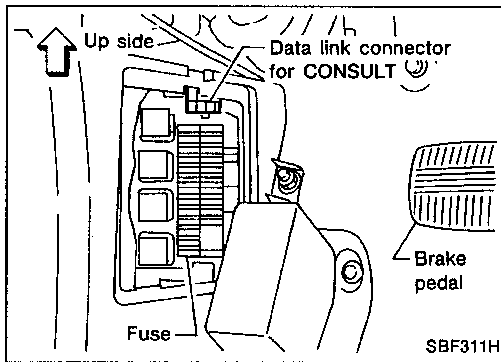

Diagnostic Procedure 1

SYMPTOM: Warning lamp flashes.

WARNING:

Determine if the flash rate is every 0.5 seconds, or 3 seconds "ON" and 2 seconds "OFF".

If every 0.5 seconds, perform self-diagnosis.

If 3 seconds "ON" and 2 seconds "OFF", the system is in Present diagnosis mode, refer to page BF-99 for instructions.

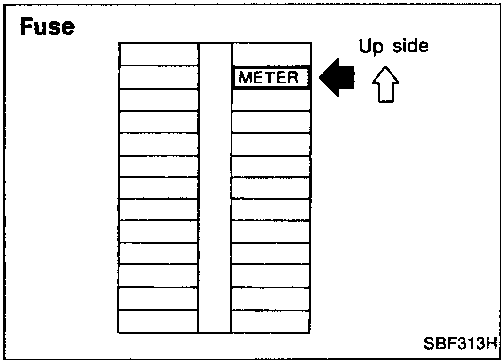
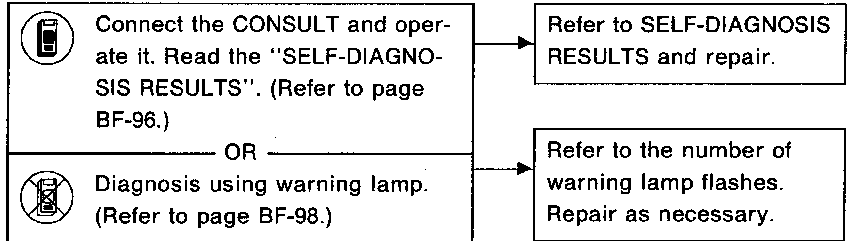

Diagnostic Procedure 2

SYMPTOM: Warning lamp does not come on.

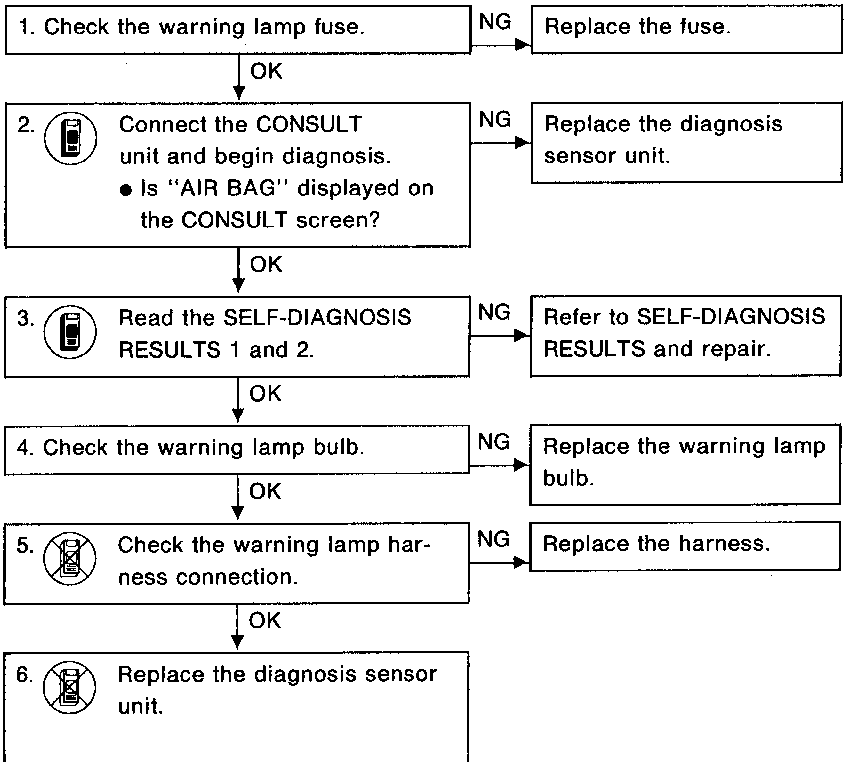
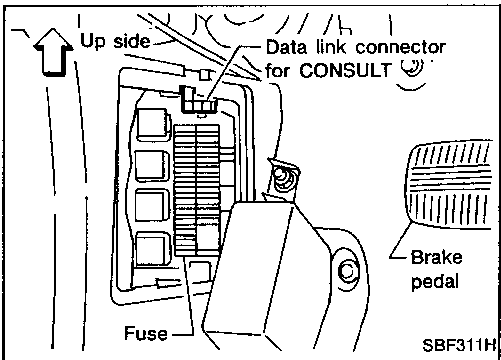

GI
MA
EM
LC
EC
FE
CL
MT
AT
PD
FA
RA
BR
ST
BF
HA
EL
IDX

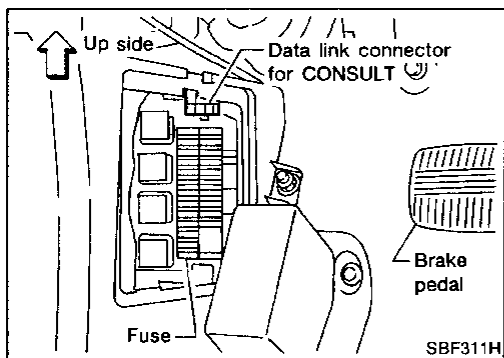
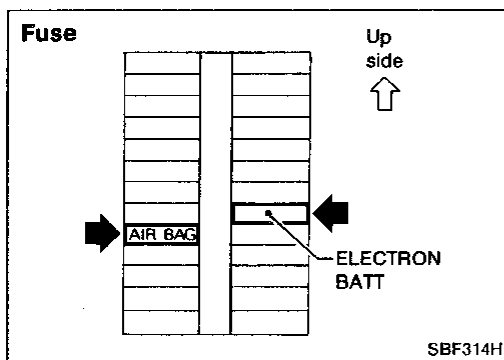

Diagnostic Procedure 3

SYMPTOM: Warning lamp does not go off.

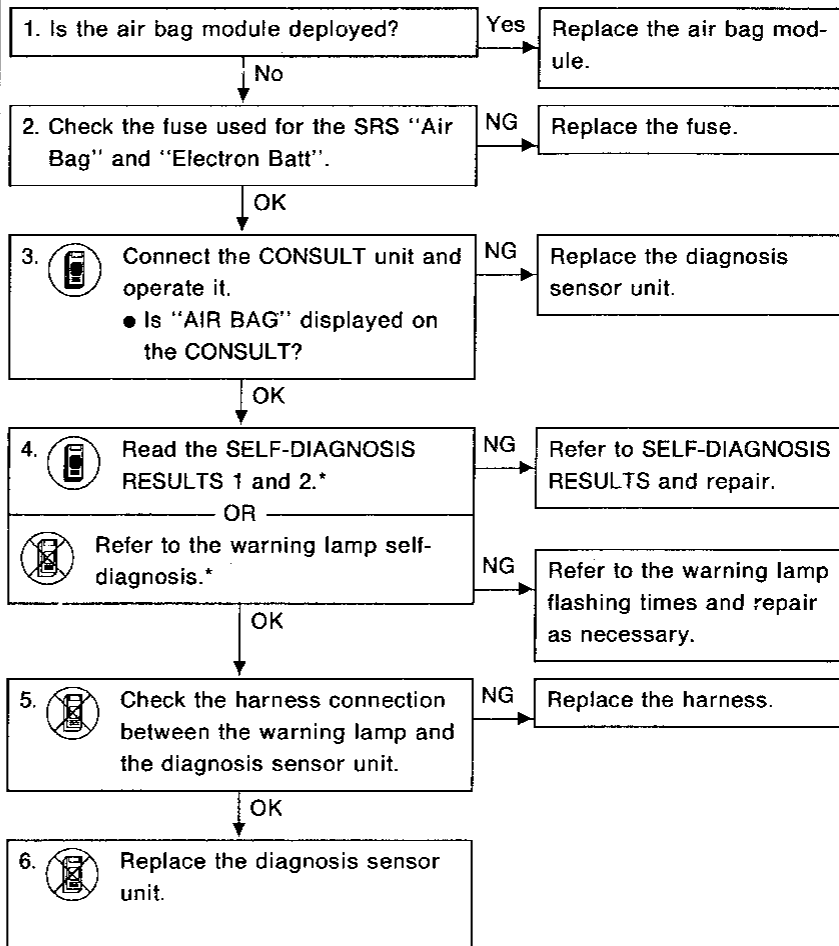

* Recheck SRS after each replacement.

Collision Diagnosis

To repair the SRS "AIR BAG", perform the following steps.

When air bag deploys in a collision:

- ① Replace the diagnosis sensor unit. GI
- ② Remove the air bag modules. MA
- ③ Check the SRS components using the table shown below:
 - If any damage is visible (such as dents, cracks or deformation), replace the damaged component. EM
- ④ Conduct self-diagnosis using CONSULT or "AIR BAG" warning lamp. Open circuits of air bag module will appear as problem codes. Ensure the remainder of the SRS is operating properly. LC
- ⑤ Install new air bag modules.
- ⑥ Conduct self-diagnosis again.

When air bag does not deploy in a collision:

- ① Check the SRS components using the table shown below:
 - If any damage is visible (such as dents, cracks or deformation), replace the damaged component. EC
- ② Conduct self-diagnosis using CONSULT or "AIR BAG" warning lamp to ensure entire SRS operates properly. FE

SRS inspection

Part	Air bag deployed	Air bag did NOT deploy	
Air bag module (driver and passenger side)	REPLACE Install with new bolts.	1. Remove air bag module. Check harness cover and connectors for damage, terminals for deformities, and harness for binding. 2. Install air bag module into the steering wheel to check fit and alignment with the wheel. 3. No damage found, reinstall with new bolts. 4. If damaged—REPLACE. Air bag must be deployed before discarding.	MT AT PD
Instrument panel	REPLACE Install with new bolts.	1. Check instrument panel for bending, deformities, or cracks. 2. If no damage is found, reinstall with new bolts. 3. If damaged—REPLACE.	FA
Diagnosis sensor unit	REPLACE Install with new bolts.	1. Check case and bracket for dents, cracks or deformities. 2. Check connectors for damage, and terminals for deformities. 3. If no damage is found, reinstall with new bolts. 4. If damaged—REPLACE.	RA
Steering wheel		1. Check harness (built into steering wheel) and connectors for damage, and terminals for deformities. 2. Install air bag module to check fit or alignment with steering wheel. 3. Check steering wheel for excessive free play. 4. If no damage is found, reinstall with new bolts. 5. If damaged—REPLACE.	BR ST
Spiral cable		1. Visually check lock (engagement) pins and combination switch for damage. 2. Check connectors, flat cable and protective tape for damage. 3. Check steering wheel for noise, binding or heavy operation. 4. If no damage is found, reinstall with new bolts. 5. If damaged—REPLACE.	BF HA
Harness and Connectors		1. Check connectors for poor connection, damage, and terminals for deformities. 2. Check harness for binding, chafing, cuts, or deformities. 3. If no damage is found, reinstall 4. Damaged—REPLACE damaged section of harness. Do not attempt to repair, splice or modify any SRS harness.	EL IDX