



CRUISE CONTROL SYSTEM

1990 Nissan 240SX

1990 ACCESSORIES & EQUIPMENT
Nissan Cruise Control Systems

Axxess, Maxima, Pathfinder, Pickup,
Stanza, 240SX, 300ZX

DESCRIPTION & OPERATION

NOTE: For system component locations, see SYSTEM COMPONENT LOCATIONS table under DESCRIPTION & OPERATION.

ACTUATOR

Actuator, located in engine compartment, consists of a vacuum diaphragm and a control valve assembly. Actuator control valve assembly regulates vacuum supply to diaphragm based on signals received from cruise control module.

Pathfinder & Pickup

System uses intake manifold vacuum as source for actuator diaphragm. Actuator control valve assembly and diaphragm is a combined unit.

All Others

Actuator control valve assembly contains a vacuum motor (pump) which supplies vacuum for actuator diaphragm. Actuator control valve assembly and diaphragm are separate units.

BRAKE CANCEL, CLUTCH (M/T) & STOPLIGHT SWITCHES

NOTE: Brake cancel switch and stoplight switch are separate switches. These switches function to disengage system. Brake cancel switch is activated by braking. DO NOT confuse brake cancel switch with the CANCEL switch on steering wheel switch. See STEERING SWITCH.

When brake pedal is applied or clutch is disengaged, switches signal the cruise control module to disengage system.

CRUISE CONTROL MODULE

Based on inputs received from various sensors, cruise control module sends signals to actuator control assembly to maintain vehicle speed.

INHIBITOR RELAY (A/T)

Inhibitor relay signals cruise control module to disengage system when transmission is in Neutral or Park.

MAIN SWITCH

Switch is mounted on instrument panel and supplies power for system.

STEERING SWITCH

Steering switch is a system control switch mounted to



steering wheel. Steering switch has 3 different switches, controlling different functions of system. On Pathfinder and Pickup, steering switch contains COAST, RESUME and ACCEL switches. On all other models, steering switch contains RESUME/ACCEL, CANCEL and SET/COAST switches.

SYSTEM COMPONENT LOCATIONS TABLE

Application	Location
Cruise Control Module	
Axxess	Behind Left Kick Panel
Maxima	Under Instrument Panel, To Right Of Steering Column
Pathfinder	Behind Left Rear Interior Quarter Panel
Pickup	Under Driver's Seat
Stanza	Under Instrument Panel, To Right Of Steering Column
240SX	Behind Right Kick Panel
300ZX	Under Interior Floor Panel, On Passenger's Side, Below Dash Panel
Cruise Control Relay (1)	
Axxess	Under Instrument Panel, Near Junction Block
Maxima & 240SX	In Relay Box, At Left Front Corner Of Engine Compartment
Pathfinder & Pickup	Right Front Corner Of Engine Compartment
Stanza	In Relay Box, At Right Front Corner Of Engine Compartment
300ZX	Behind Dash Panel, To Right Of Center (Relay Is Brown)
Vehicle Speed Sensor	
Pathfinder & Pickup	In Speedometer Unit At Instrument Panel
All Others	Mounted To Transmission

(1) - See Figs. 1-5.

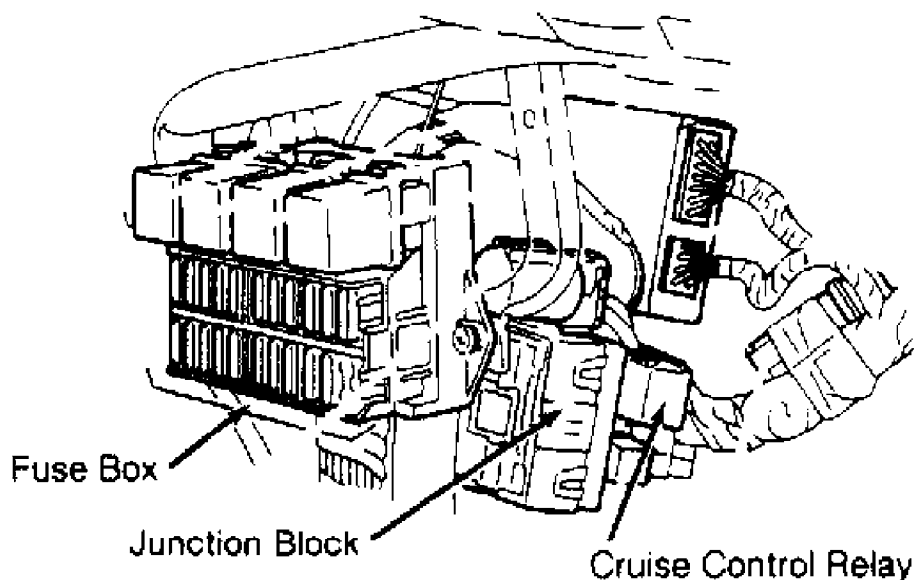

AXXESS

Fig. 1: Locating Cruise Control Relay (Axxess)
 Courtesy of Nissan Motor Co., U.S.A.

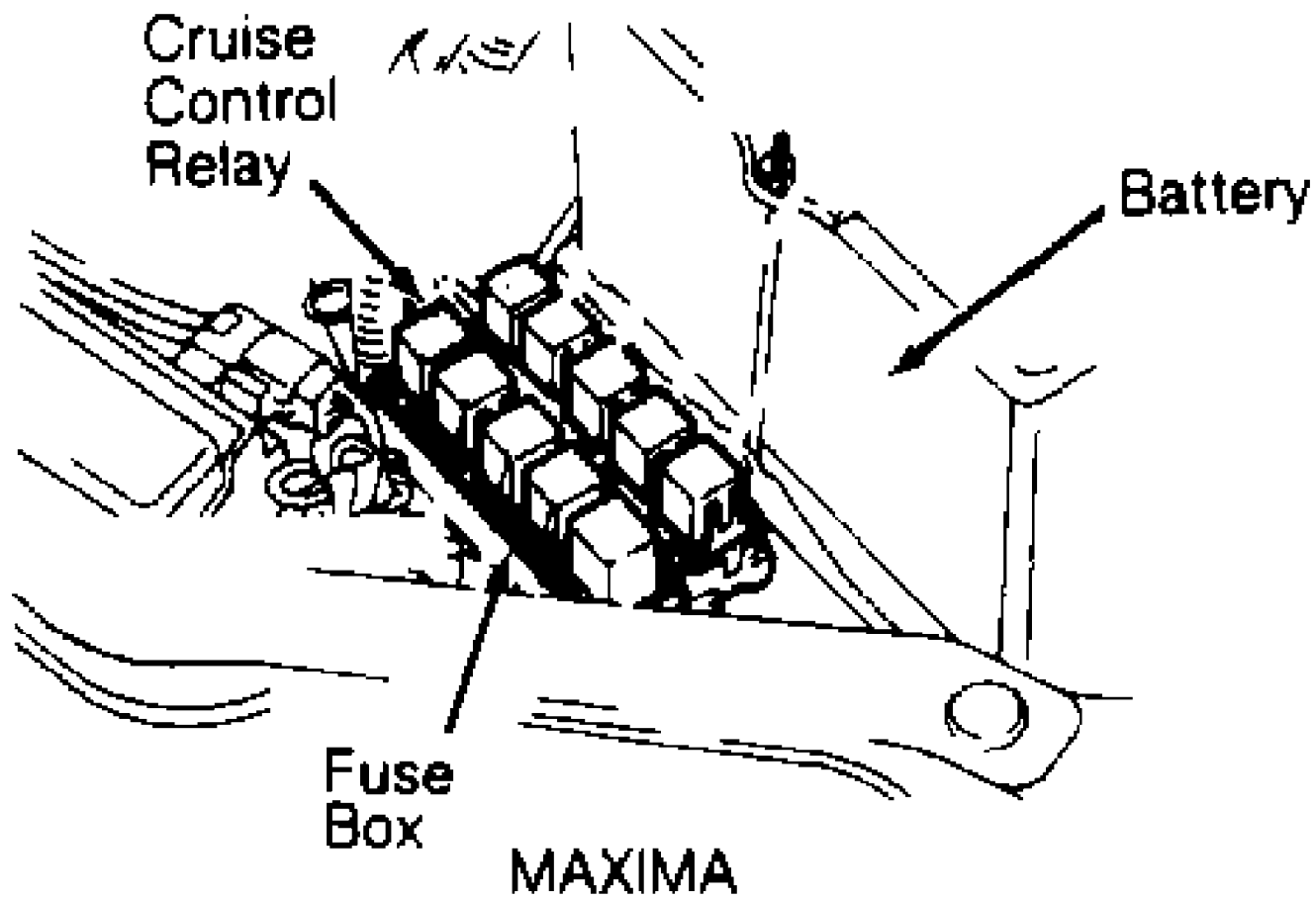

Fig. 2: Locating Cruise Control Relay (Maxima)
Courtesy of Nissan Motor Co., U.S.A.

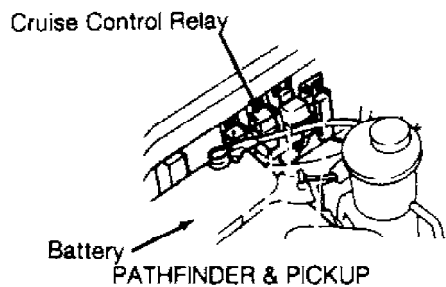

Fig. 3: Locating Cruise Control Relay (Pathfinder & Pickup)
Courtesy of Nissan Motor Co., U.S.A.

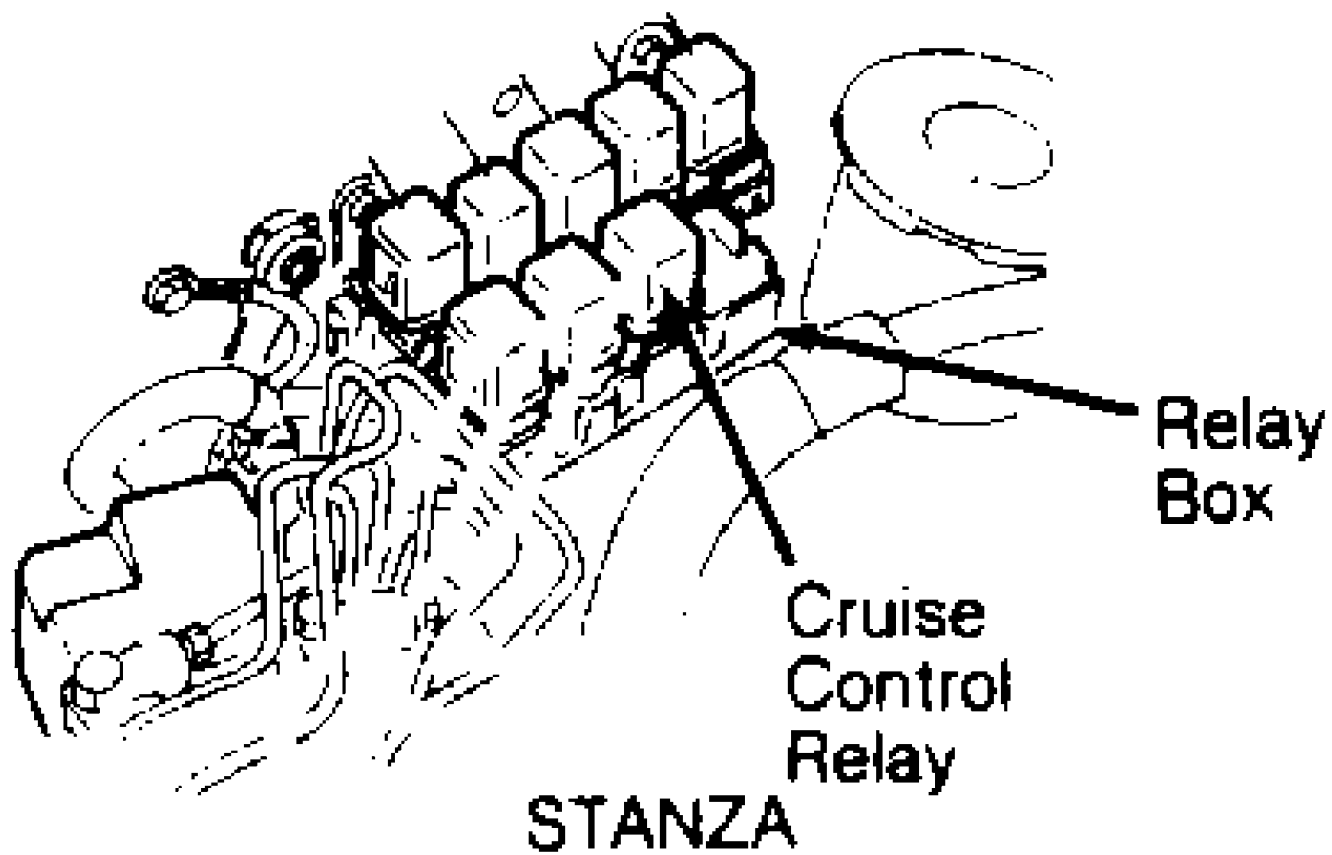

Fig. 4: Locating Cruise Control Relay (Stanza)
Courtesy of Nissan Motor Co., U.S.A.

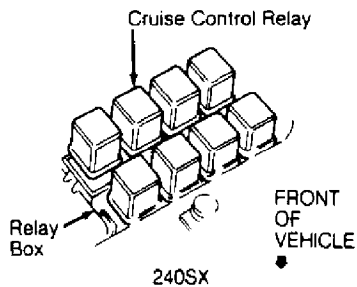

Fig. 5: Locating Cruise Control Relay (240SX)
Courtesy of Nissan Motor Co., U.S.A.

TROUBLE SHOOTING

NOTE: For system component locations, see SYSTEM COMPONENT LOCATIONS table under DESCRIPTION & OPERATION.

SYSTEM WILL NOT ENGAGE

Pathfinder & Pickup

1) Turn ignition on. Turn cruise control main switch to ON position. If indicator light does not illuminate, check main switch. If main switch is okay, perform CRUISE CONTROL RELAY test under TESTING.

2) If indicator light illuminates, check for loose or disconnected vacuum hoses. Perform POWER SUPPLY CIRCUIT test under TESTING. If power supply circuit is okay, go to step 3). If power supply circuit is inoperative, check brake cancel switch, clutch switch (M/T), inhibitor relay (A/T) and inhibitor switch (A/T).

3) Perform SET/COAST SWITCH CIRCUIT test under TESTING. If COAST switch circuit is okay, perform ACTUATOR test under TESTING. If actuator is okay, perform SPEED SENSOR CIRCUIT test under TESTING. If speed sensor circuit is okay, replace cruise control module.

All Others

1) Turn ignition on. Turn cruise control main switch to ON position. If indicator light illuminates, go to step 2). If indicator light does not illuminate, check main switch. If main switch is okay, perform CRUISE CONTROL RELAY test under TESTING.

2) Perform POWER SUPPLY CIRCUIT test under TESTING. If power supply circuit is okay, perform CUT-OFF CIRCUIT test under TESTING.

3) If cut-off circuit is NOT okay, check brake cancel switch, clutch switch (M/T), inhibitor relay (A/T) and inhibitor switch (A/T). If cut-off circuit is okay, go to step 4).

4) Perform SET/COAST SWITCH CIRCUIT test under TESTING. If SET/COAST switch circuit is not okay, perform SPEED SENSOR CIRCUIT test under TESTING. If speed sensor circuit is okay, perform ACTUATOR test under TESTING. If actuator is okay, replace cruise control module.

SYSTEM WILL NOT DISENGAGE

Pathfinder & Pickup

Perform ACTUATOR test under TESTING. If actuator tests okay, replace cruise control module.

All Other Models

1) If system will not disengage when the brake or clutch (M/T) pedals are pressed or when transmission is placed in Park or Neutral, perform CUT-OFF CIRCUIT test under TESTING.

2) If cut-off circuit is okay, go to step 3). If cut-off circuit does not test okay, check brake cancel switch, clutch switch (M/T), inhibitor relay (A/T) and inhibitor switch (A/T).

3) Perform ACTUATOR test under TESTING. If actuator tests okay, replace cruise control module.

ENGINE SURGES

All Models

Check for loose, cracked or disconnected vacuum hoses. Ensure actuator cable moves smoothly. Repair or replace actuator cable if cable does not move smoothly. If actuator cable moves smoothly, perform ACTUATOR test under TESTING. If actuator is okay, replace cruise control module.

CANCEL FUNCTION INOPERATIVE

Except Pathfinder & Pickup

Perform CANCEL SWITCH CIRCUIT test under TESTING. If CANCEL switch circuit is okay, replace cruise control module.

RESUME FUNCTION INOPERATIVE

All Models

Perform RESUME SWITCH CIRCUIT test for the specific model under TESTING. If RESUME/ACCEL (RESUME only on Pathfinder and Pickup) switch circuit is okay, replace cruise control module.

ACCEL FUNCTION INOPERATIVE

NOTE: Only Pathfinder and Pickup models have a separate ACCEL switch.

Pathfinder & Pickup

Perform ACCEL SWITCH CIRCUIT test under TESTING. If ACCEL switch circuit tests okay, replace cruise control module.

VARIATION BETWEEN SET SPEED & ACTUAL VEHICLE SPEED

All Models

Ensure actuator cable moves smoothly. Replace actuator cable if cable does not move smoothly. If actuator cable moves smoothly, check for loose, cracked or disconnected vacuum hoses. If vacuum hoses are okay, perform ACTUATOR test under TESTING. If actuator is okay, replace cruise control module.

OVERDRIVE CANCEL FUNCTION INOPERATIVE

Except Maxima

Perform OVERDRIVE CANCEL CIRCUIT test under TESTING. If overdrive cancel circuit is okay, replace cruise control module.

ACTUATOR CABLE ADJUSTMENT

NOTE: Before adjusting actuator (cruise control) cable, ensure throttle cable is properly adjusted. DO NOT twist or overtighten cable wire during adjustment procedure.

Loosen actuator cable adjusting nuts. Without pressing accelerator pedal, adjust cable until there is no free play. Back off cable adjusting nut 1/2-1 turn to allow slight free play in cable. Tighten cable adjusting nuts.

BRAKE CANCEL, CLUTCH (M/T) & STOPLIGHT SWITCHES ADJUSTMENT

All switches are adjusted in same manner. Loosen lock nut and turn adjusting nut until clearance between tip of switch and pedal is .012-.04" (.3-1 mm).

ACCEL SWITCH CIRCUIT TESTING

NOTE: For system component locations, see SYSTEM COMPONENT LOCATIONS table under DESCRIPTION & OPERATION.

PATHFINDER & PICKUP

1) Ensure ignition is off. Press and hold ACCEL switch. Check continuity between cruise control module connector terminals No. 3 and 14. See Fig. 9.

2) If there is continuity, circuit is okay. If there is no continuity, check ACCEL switch wiring circuit. If ACCEL switch wiring circuit is okay, replace ACCEL switch.

ALL OTHERS

See RESUME SWITCH CIRCUIT TEST.

ACTUATOR TESTING

AXXESS

1) Turn ignition off. Disconnect actuator harness connector from main harness. Connect battery positive lead to actuator connector terminal No. 3 and negative lead to terminal No. 2. See Fig. 6. If vacuum motor does not operate, replace actuator. If vacuum motor operates, go to step 2).

2) Connect battery positive lead to terminal No. 3 and negative lead to terminals No. 1, 2 and 4 (simultaneously). If actuator wire moves, go to step 3). If actuator wire does not move, replace actuator.

3) With battery leads connected to actuator terminals as in step 2), disconnect negative lead from terminal No. 4. If actuator wire returns to original position 50-60 seconds after disconnecting negative lead from terminal No. 4, go to step 4). If actuator wire does not return as specified, replace actuator.

4) With battery leads connected to actuator terminals as in step 2), disconnect negative lead from terminal No. 1. If actuator wire immediately returns to original position, actuator is okay. If actuator wire does not immediately return to original position, replace actuator.

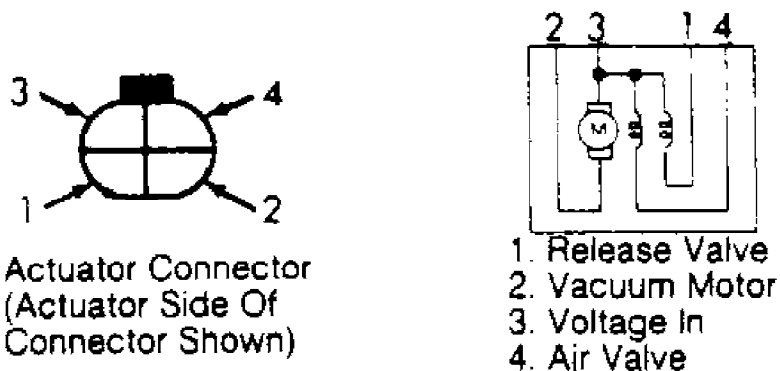

Fig. 6: Identifying Actuator Connector Terminals (Axxess)
Courtesy of Nissan Motor Co., U.S.A.

MAXIMA, STANZA, 240SX & 300ZX

1) Turn ignition off. Disconnect actuator harness connector from main harness. Connect battery positive lead to actuator connector terminal No. 1 and negative lead to terminal No. 4. See Fig. 7. If vacuum motor does not operate, replace actuator. If vacuum motor operates, go to step 2).

2) Connect battery positive lead to terminal No. 1 and negative lead to terminals No. 2, 3 and 4 (simultaneously). If actuator wire moves, go to step 3). If actuator wire does not move, replace actuator.

3) With battery leads connected to terminals as in step 2), disconnect negative lead from terminal No. 2. If actuator wire returns to original position 50-60 seconds after disconnecting negative lead from terminal No. 2, go to step 4). If actuator wire does not return as specified, replace actuator.

4) With battery leads connected to terminals as in step 2), disconnect negative lead from terminal No. 3. If actuator wire immediately returns to original position, actuator is okay. If actuator wire does not immediately return to original position, replace actuator.

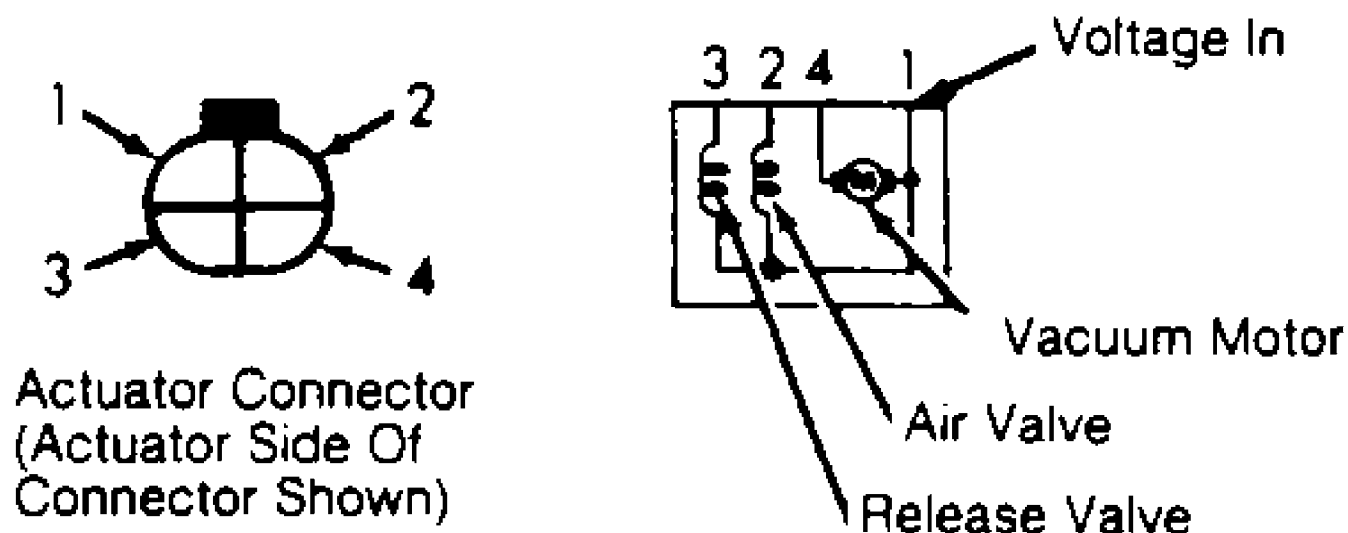

Fig. 7: Identifying Actuator Connector Terminals (Maxima, Stanza, 240SX & 300ZX)

Courtesy of Nissan Motor Co., U.S.A.

PATHFINDER & PICKUP

1) Check continuity between actuator connector terminal No. 1 and terminals No. 2, 3 and 4. See Fig. 8. If continuity is NOT present, replace actuator. If continuity exists, disconnect vacuum hose from fitting on actuator.

2) Apply light vacuum to actuator (DO NOT use engine vacuum). Connect battery positive lead to terminal No. 1 and negative lead to terminals No. 2, 3 and 4 (simultaneously). If actuator does not move smoothly, replace actuator.

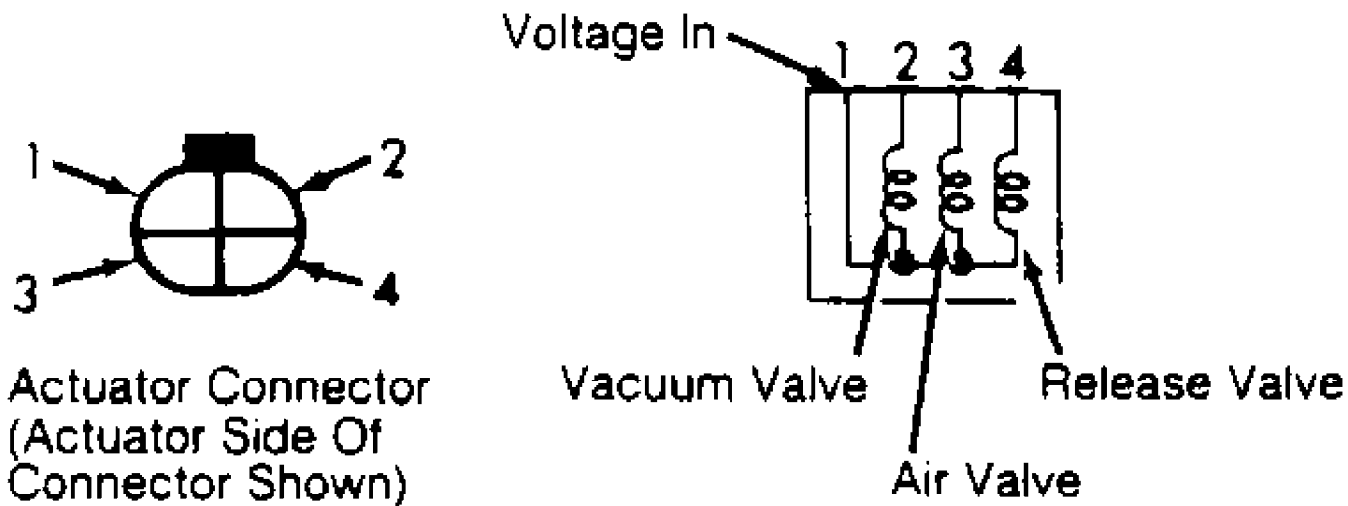

Fig. 8: Identifying Actuator Connector Terminals (Pathfinder & Pickup)
Courtesy of Nissan Motor Co., U.S.A.

CANCEL SWITCH CIRCUIT TESTING

ALL MODELS EXCEPT PATHFINDER & PICKUP

1) Turn ignition on. Turn cruise control main switch to ON position. Press and hold CANCEL switch. Measure voltage between cruise control module connector terminals No. 1 and 3, and terminals No. 2 and 3. See Fig. 9.

2) If battery voltage is present in each case, CANCEL switch circuit is okay. If battery voltage is not present in each case, check CANCEL switch wiring circuit. If CANCEL switch wiring circuit is okay, replace CANCEL switch.

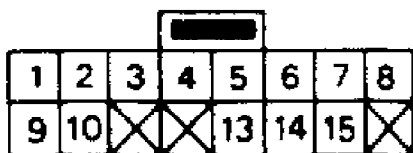

AXXESS, PATHFINDER & PICKUP

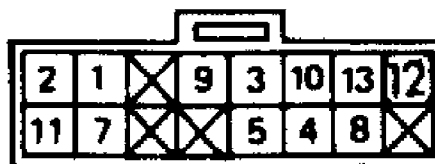

ALL OTHERS

(Component Side Of Connector Shown)

Fig. 9: Identifying Cruise Control Module Connector Terminals
Courtesy of Nissan Motor Co., U.S.A.

CRUISE CONTROL RELAY TESTING

300ZX

1) Check continuity between cruise control relay terminals No. 1 and 2. See Fig. 10. If there is continuity, go to step 2). If continuity is NOT present, replace relay.

2) Check continuity between terminals No. 3 and 5, and terminals No. 6 and 7. If there is continuity, replace relay. If there is no continuity, energize relay by connecting 12-volt source across terminals No. 1 and 2.

3) With relay energized, check continuity between terminals No. 3 and 5, and terminals No. 6 and 7. If there is continuity in each test, relay is okay. If there is no continuity in one or both tests, replace relay.

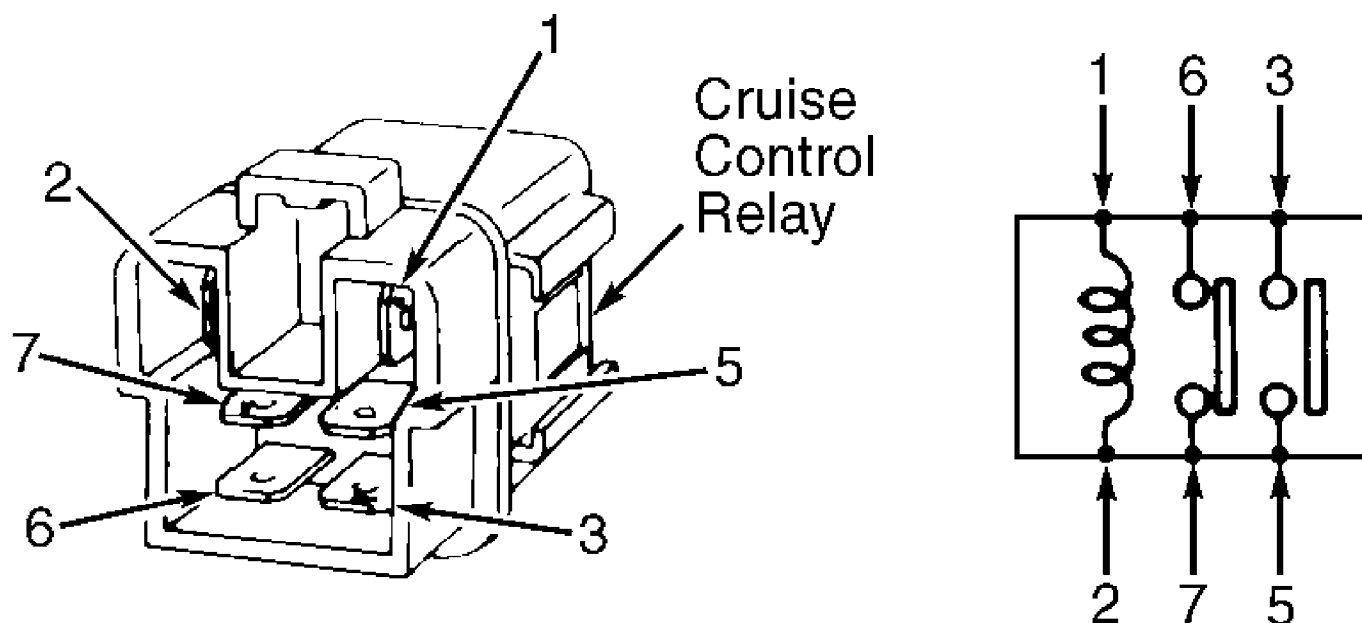

91D00789

Fig. 10: Identifying Cruise Control Relay Connector Terminals (300ZX)
Courtesy of Nissan Motor Co., U.S.A.

ALL OTHERS

1) Remove relay. Check continuity between terminals No. 1 and 2. See Fig. 11. If continuity is NOT present, replace relay. If continuity exists, check continuity between terminals No. 3 and 5.

2) If continuity exists, replace relay. If continuity is NOT present, energize relay by connecting 12-volt source across terminals No. 1 and 2. With relay energized, check continuity between terminals No. 3 and 5.

3) If there is no continuity, replace relay. If there is continuity, relay is okay.

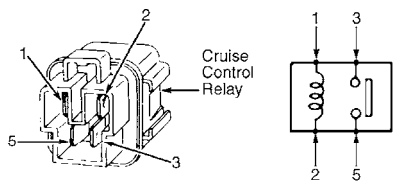

91G00790
Fig. 11: Identifying Cruise Control Relay Connector Terminals
(Except 300ZX)

Courtesy of Nissan Motor Co., U.S.A.

CUT-OFF CIRCUIT TESTING

EXCEPT PATHFINDER & PICKUP

1) Turn ignition on. Turn cruise control main switch to ON position. Press and hold brake pedal. Press clutch pedal (M/T) or shift into Neutral (A/T). Measure voltage between cruise control module connector terminals No. 3 and 11 (terminals No. 5 and 9 on Axxess). See Fig. 9.

2) If battery voltage is present, cut-off circuit is okay. If battery voltage is NOT present, check cut-off circuit wiring.

GROUND CIRCUIT TESTING

ALL MODELS

Using an ohmmeter, check continuity between ground and cruise control module connector terminal No. 3 (terminal No. 5 on Axxess, Pathfinder & Pickup). See Fig. 9. If there is no continuity, repair circuit between cruise control module connector and ground.

OVERDRIVE CANCEL CIRCUIT TESTING (A/T)

AXXESS

Turn ignition on. Turn cruise control main switch to ON position. Place transmission overdrive switch in ON position. Measure voltage between cruise control module connector terminals No. 5 and 8. See Fig. 9. If battery voltage is NOT present, overdrive cancel wiring circuit is okay. If battery voltage is present, check overdrive cancel wiring circuit.

PATHFINDER & PICKUP

Ensure ignition is off. Check continuity between terminals No. 5 and 8 of cruise control module connector. See Fig. 9. If continuity is present, overdrive cancel wiring circuit is okay. If continuity is NOT present, check overdrive cancel wiring circuit.

STANZA, 240SX & 300ZX

Turn ignition on. Turn cruise control main switch to ON position. Place transmission overdrive switch in ON position. Measure voltage between cruise control module connector terminals No. 3 and 12. See Fig. 9. If battery voltage is NOT present, check overdrive cancel wiring circuit.

POWER SUPPLY CIRCUIT TESTING

ALL MODELS

1) Release all pressure from brake and clutch pedals. Turn ignition on. Turn cruise control main switch to ON position.

2) If vehicle is equipped with automatic transmission, place in Drive. On Axxess, measure voltage between cruise control module connector terminals No. 5 and 14. On Pathfinder and Pickup, measure voltage between terminals No. 5 and 13. On all other models, measure

voltage between terminals No. 3 and 4. See Fig. 9.

3) If battery voltage is present, power supply circuit is okay. If battery voltage is NOT present, check power supply wiring circuit.

RESUME SWITCH CIRCUIT TEST

PATHFINDER & PICKUP

1) Turn ignition off. Press and hold RESUME switch. Using an ohmmeter, check continuity between cruise control module connector terminals No. 2 and 14. See Fig. 9.

2) If there is continuity, circuit is okay. If there is no continuity, check RESUME switch wiring circuit. If RESUME switch wiring circuit is okay, replace RESUME switch.

ALL OTHERS

Turn ignition on. Turn main switch to ON position. Press and hold RESUME/ACCEL switch. Measure voltage between cruise control module connector terminals No. 1 and 3 (terminals No. 2 and 5 on Axxess). See Fig. 9. If battery voltage is NOT present, check RESUME/ACCEL switch wiring circuit. If RESUME/ACCEL switch wiring circuit is okay, replace RESUME/ACCEL switch.

SET/COAST SWITCH CIRCUIT TESTING

PATHFINDER & PICKUP

1) Turn ignition off. Push and hold COAST switch. Using an ohmmeter, check continuity between cruise control module connector terminals No. 1 and 14. See Fig. 9.

2) If there is continuity, COAST switch circuit is okay. If there is no continuity, check COAST switch wiring circuit. If COAST switch wiring circuit is okay, replace COAST switch.

ALL OTHERS

1) Turn ignition on. Turn cruise control main switch to ON position. Press and hold SET/COAST switch. Measure voltage between cruise control module connector terminals No. 2 and 3 (terminals No. 1 and 5 on Axxess). See Fig. 9.

2) If battery voltage is NOT present, check SET/COAST switch wiring circuit. If SET/COAST switch wiring circuit is okay, replace SET/COAST switch.

SPEED SENSOR CIRCUIT TESTING

PATHFINDER & PICKUP

1) Ensure ignition is off. Disconnect speedometer cable from transmission. Connect ohmmeter between cruise control module connector terminals No. 5 and 10. See Fig. 9.

2) Turn ignition on. Slowly rotate speedometer cable pinion by hand. If ohmmeter does not deflect twice for each revolution, check speed sensor wiring circuit.

ALL OTHERS

1) Turn ignition on. Turn cruise control main switch to ON position. Remove speed sensor from transmission. With wiring harness connected to sensor, connect a voltmeter between cruise control module connector terminals No. 3 and 7 (terminals No. 5 and 10 on Axxess). See Fig. 9. Slowly rotate sensor gear by hand.

2) If voltmeter does not deflect twice for each revolution, check speed sensor wiring circuit.

ACTUATOR R & I

Turn ignition off. Disconnect actuator harness connector, vacuum hose and cable from actuator. Remove actuator attaching bolt. To install, reverse removal procedure.

ACTUATOR CABLE R & I

Disconnect cable from actuator. Remove screw attaching cable bracket. Remove rubber boots. Loosen lock nuts and remove cable from torsion shaft. To install cable, reverse removal procedure and adjust.

BRAKE CANCEL, CLUTCH & STOPLIGHT SWITCHES R & I

Disconnect negative battery cable. Remove instrument panel lower left cover. Disconnect wiring harness from switch. Loosen lock nut and remove switch. To install, reverse removal procedure and adjust. See ADJUSTMENTS.

CRUISE CONTROL MODULE R & I

For cruise control module location, see SYSTEM COMPONENT LOCATIONS table under DESCRIPTION & OPERATION. Turn ignition off. Disconnect negative battery cable. Remove cruise control module mounting hardware. Remove cruise control module and disconnect harness connector. To install, reverse removal procedure.

MAIN SWITCH R & I

Disconnect negative battery cable. Push switch out from behind instrument panel or from below console. Disconnect harness connector from main switch. To install, reverse removal procedure.

WIRING DIAGRAMS

See appropriate chassis wiring diagram in WIRING DIAGRAMS.