

Operation Manual

WARNING:

THIS EQUIPMENT GENERATES AND USES RADIO FREQUENCY ENERGY AND IF NOT INSTALLED AND USED PROPERLY, I.E., IN STRICT ACCORDANCE WITH THE INSTRUCTIONS MANUAL, MAY CAUSE HARMFUL INTERFERENCE TO RADIO COMMUNICATIONS. IT HAS BEEN TESTED AND FOUND TO COMPLY WITH THE LIMITS FOR A CLASS A COMPUTING DEVICE PURSUANT TO SUBPART J OF PART 15 OF FCC RULES, WHICH ARE DESIGNED TO PROVIDE REASONABLE PROTECTION AGAINST SUCH INTERFERENCE WHEN OPERATED IN A COMMERCIAL ENVIRONMENT.

OPERATION OF THIS EQUIPMENT IN A RESIDENTIAL AREA IS LIKELY TO CAUSE INTERFERENCE IN WHICH CASE THE USER AT HIS OWN EXPENSE WILL BE REQUIRED TO TAKE WHATEVER MEASURES MAY BE REQUIRED TO CORRECT THE INTERFERENCE.

UNIVERSAL

UNIVERSAL

IV. VARIOUS OPTIONAL SETTINGS

A. SERVICE SWITCHES AND DIP SWITCHES

• Dip Switch A

1. Number of Mr. Do's (SW1, 2)

No. of Mr. Do's	SW1	SW2
3	OFF	OFF
4	OFF	ON
5	ON	OFF
2	ON	ON

2. Game Style (SW3)

Style	SW3
Table	OFF
Upright	ON

3. Ease or Hardness of "EXTRA" (SW4)

Ease or Hardness	SW4
Easy to win	OFF
Hard to win	ON

4. Ease or Hardness of "SPECIAL" (SW5)

Ease or Hardness	SW5
Easy to win	OFF
Hard to win	ON

5. Automatic Screen Renewal (SW6)

Automatic screen renewal	SW6
Can	OFF
Cannot	ON

• Dip Switch B (Coin & Credit)

Coin	Credit	Left-side chute				Right-side chute			
		SW1	SW2	SW3	SW4	SW5	SW6	SW7	SW8
1	1	OFF	OFF	OFF	OFF	OFF	OFF	OFF	OFF
1	2	OFF	OFF	OFF	ON	OFF	OFF	OFF	ON
1	3	OFF	OFF	ON	OFF	OFF	OFF	ON	OFF
1	4	OFF	OFF	ON	ON	OFF	OFF	ON	ON
1	5	OFF	ON	OFF	OFF	OFF	ON	OFF	OFF
2	1	OFF	ON	OFF	ON	OFF	ON	OFF	ON
2	3	OFF	ON	ON	OFF	OFF	ON	ON	OFF
3	1	OFF	ON	ON	ON	OFF	ON	ON	ON
3	2	ON	OFF	OFF	OFF	ON	OFF	OFF	OFF
4	1	ON	OFF	OFF	ON	ON	OFF	OFF	ON
1	1	ON	OFF	ON	OFF	ON	OFF	ON	OFF
1	1	ON	OFF	ON	ON	ON	OFF	ON	ON
1	1	ON	ON	OFF	OFF	ON	ON	OFF	OFF
1	1	ON	ON	OFF	ON	ON	ON	OFF	ON
1	1	ON	ON	ON	OFF	ON	ON	ON	OFF
Free play		ON	ON	ON	ON	ON	ON	ON	ON

6. Ease or Hardness of Game (SW7, 8)

Ease or Hardness	SW7	SW8
1 (Average)	OFF	OFF
2	OFF	ON
3	ON	OFF
4 (Hard)	ON	ON

• Position of Dip Switch/Service Switch

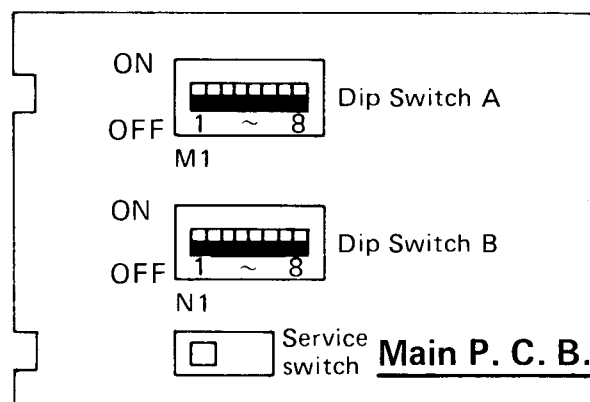

• Service Switch

When pressing the service switch, credit is increased by setting the left-side chute.

Standard and Custom Price Settings

The game price set by a combination of dip SWs is displayed on the monitor when coin credit is 0.

- When the settings for right and left chutes are the same, "1 coin – 1 credit", "2 coins – 3 credits", etc. are displayed.
- When the settings for right and left chutes are provided differently, their respective contents can be displayed.

UNIVERSAL

V.HOW TO CONDUCT SELF-TESTING

★ This machine has a self-testor which locates any abnormalities with the machine should they occur.

[Self-Testing Procedure]

Turn power ON while pressing the push-button or either the 1st or the 2nd player side, and self-testing will follow automatically.

[Self-Testing Items]

(1) ROM Test:

When normal — "ROM OK" will appear on the screen, and the test will proceed to the next step.

When abnormal — "ROM " will appear, and the test will be suspended.

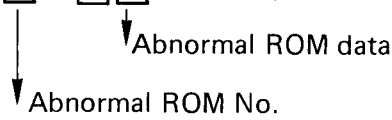

(2) RAM Test:

When normal — "RAM OK" will appear on the screen, and the test will proceed to the next step.

When abnormal — "RAM " will appear, and the test will be suspended.



(3) Sound OFF:

"SOUND OFF" will appear on the screen, and the sound that has been made to that time will stop, then, the test will proceed to the next step. The machine is out of order if the sound does not stop or the test does not proceed to the next step.

(4) Switch Test:

Switch names are displayed on the left side of the screen, while input conditions will be displayed on the right side. When the switch is ON, "0" is displayed for input, and when it is OFF, "1" is displayed. Conduct test while turning each switch ON-OFF — the test will advance to the next step after a minute.

Switch name		Input condition
TILT		
SELECT	— 2P	1
"	— 1P	1
1P side pushbutton		0
1P side joystick	Up	1
"	Right	1
"	Down	1
"	Left	1
COIN	Right	1
	Left	1
Not used		1
2P side pushbutton		1
2P side joystick	Up	1
"	Right	1
"	Down	1
"	Left	1

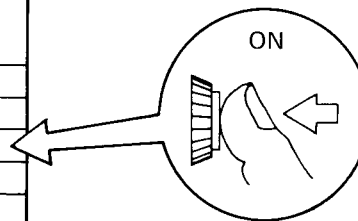

"0" will appear when pushing the pushbutton on the 1st player's side.

Dip switch A	1	0	1	1	0	1	1	1
" B	1	1	1	1	1	1	1	0

(5) TV Monitor Test:

Cross hatch pattern will appear on the entire screen. Monitor adjustment can be done by means of the pattern.

- Self-testing will stop at this point. Turn ON power again when you want to resume game or execute self-test again.

* In case you have found any abnormality as a result of the self-test, contact the dealer who sold the machine to you.

X. CIRCUIT BOARD

A. CIRCUIT BOARD IC LOCATION AND PARTS LIST

a) Main circuit board IC location and parts list

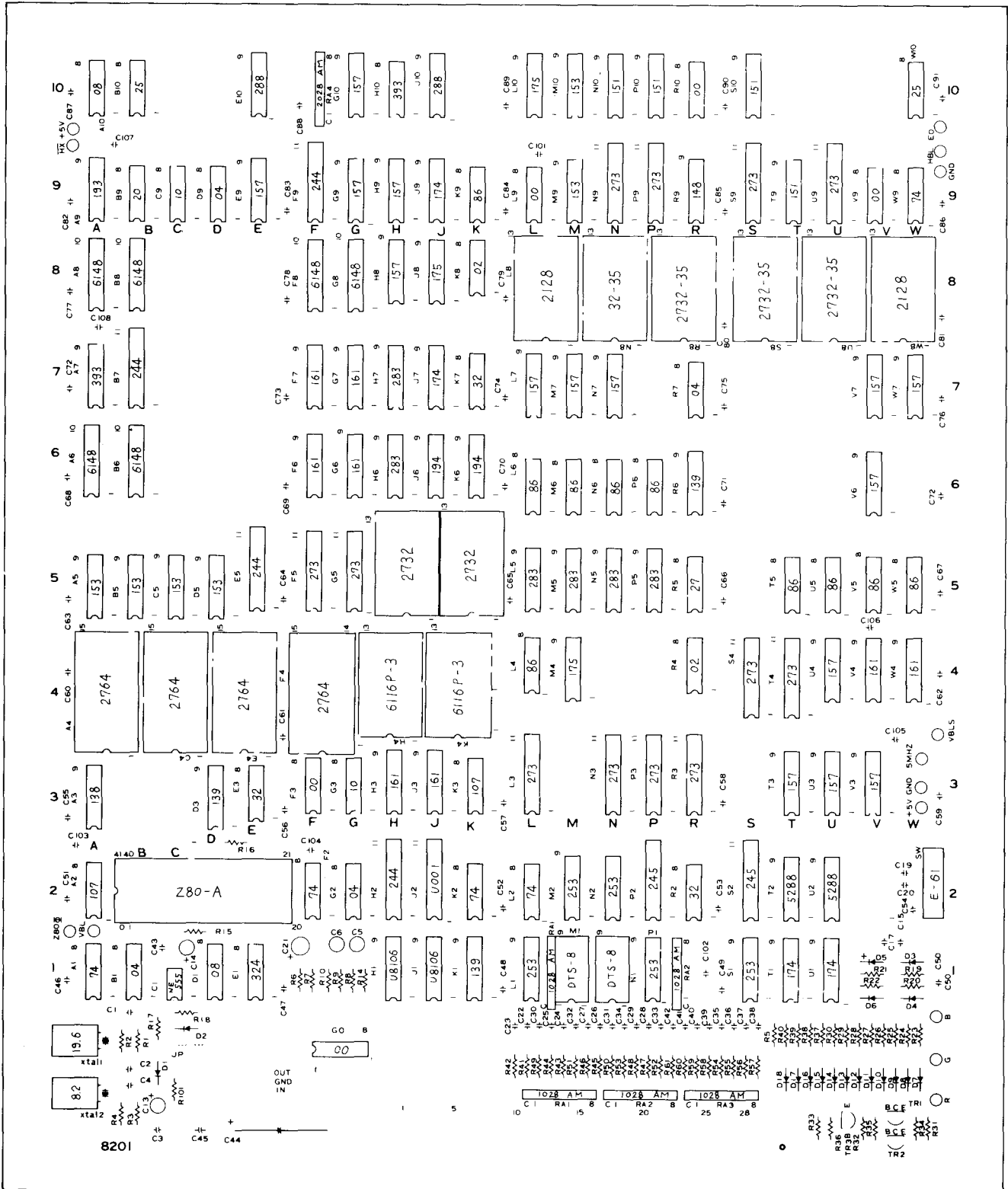

Fig. 18 Main Circuit Board

[1] Integrated Circuit

Item No.	Q'ty	Description
74LS 00	6	TTL
74LS 02	2	"
74LS 04	3	"
74 S 04	1	"
74LS 08	2	"
74LS 10	2	"
74LS 20	1	"
74 25	2	"
74LS 27	1	"
74LS 32	3	"
74LS 74	5	"
74LS 86	10	"
74LS107	2	"
74 148	1	"
74LS151	4	"
74LS153	6	"
74LS138	1	"
74LS139	3	"
74LS157	15	"
74LS161	8	"
74LS174	4	"
74LS175	3	"
74LS193	1	"
74LS194	2	"
74LS224	4	"
74LS245	2	"
74LS253	5	"
74LS273	13	"
74LS283	6	"
74LS393	2	"
74 S288 (TBP18S030)	4	256 bits Fuse ROM
U001	1	Special Function
NE555	1	Timer
Z80A	1	NMOS CPU (4MHz)
2732	6	NMOS 32K bits EP ROM (Access 350nsec)
2764	4	NMOS 64K bits EP ROM (Access 300nsec)
6148P	6	CMOS 4K bits High Speed RAM (Access 70nsec)
6116R-3	2	CMOS 16K bits Static RAM (Access 150nsec)
2128	2	NMOS 16K bits Static RAM (Access 200nsec)
LM324	1	Quad Operational Amplifiers
U8106	2	Programable Sound Generator

[2] Other Semiconductor Devices

Item No.	Q'ty	Description
2SC2785	3	Transistor
10D-1	4	Diode
1S1588	12	"

[3] Capacitors

Rating	Q'ty	Description
50PF/ 12V	2	Ceramic Capacitor
100PF/ "	1	"
220PF/ "	3	"
470PF/ "	1	"
0.01μF/ "	2	"
0.1μF/ "	70	"
10μF/ 16V	2	Chemical Capacitor
47μF/ "	1	"
1μF/ "	2	" (Nonpolar)

[4] Resistors

Rating	Q'ty	Description
47Ω ¼W	1	Carbon Solid
51Ω "	3	"
75Ω "	3	"
100Ω "	7	"
120Ω "	3	"
150Ω "	3	"
200Ω "	24	"
220Ω "	3	"
330Ω "	1	"
1KΩ "	1	"
3KΩ "	1	"
10KΩ "	2	"
47KΩ "	2	"
100KΩ "	3	"
MS1028AM	5	1KΩ Resistor Array
MS2028AM	1	2KΩ Resistor Array

[5] Misc

Name	Q'ty	Description
Dip SW	2	8 Elements Switch Array
X tal	2	8.2MHz 19.6MHz
E61-00A	1	Micro SW

This drawing provides standard information. Universal reserves the right to change without notice.

UNIVERSAL

WIRING DIAGRAM (CONNECTOR)

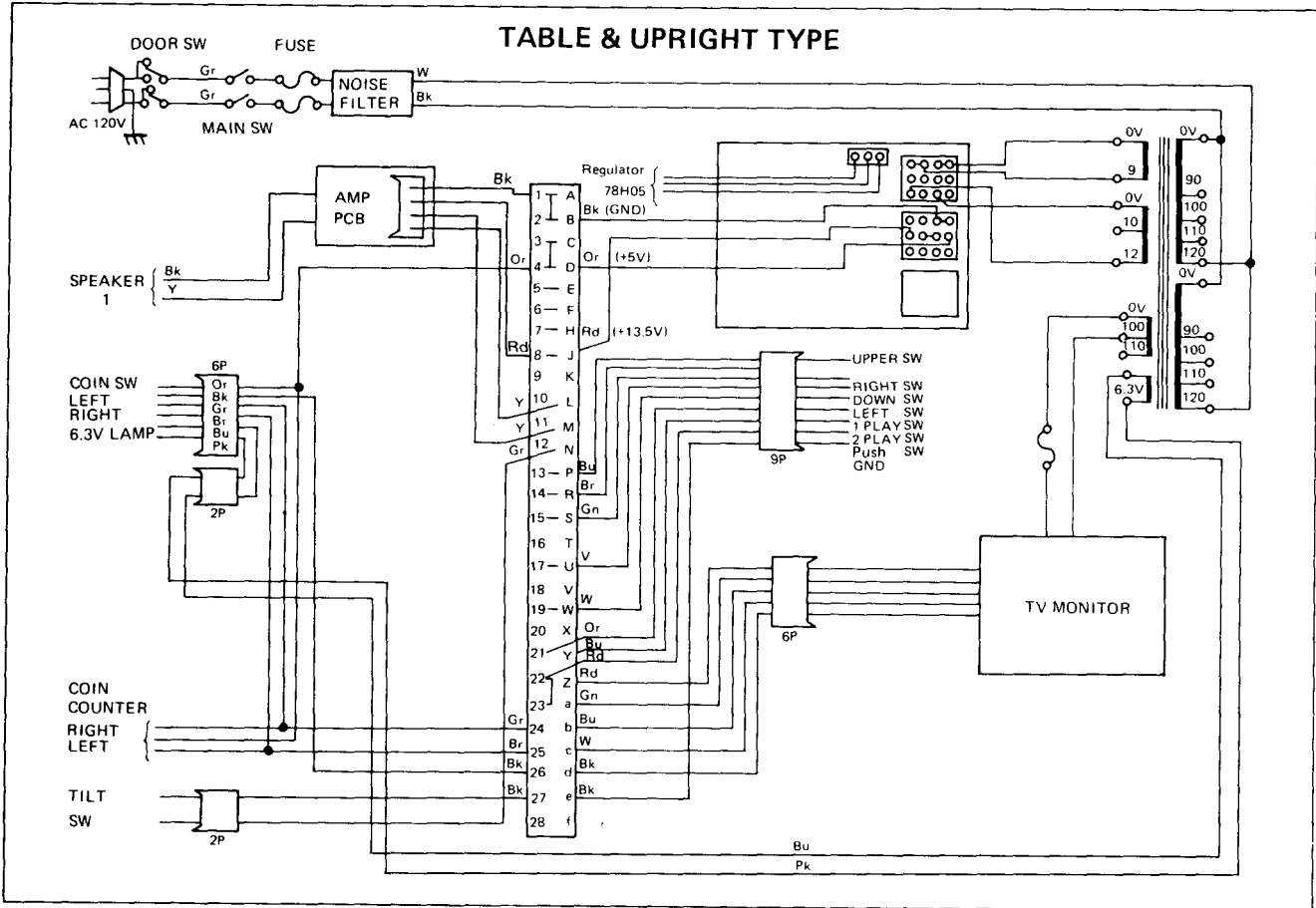

BLOCK DIAGRAM

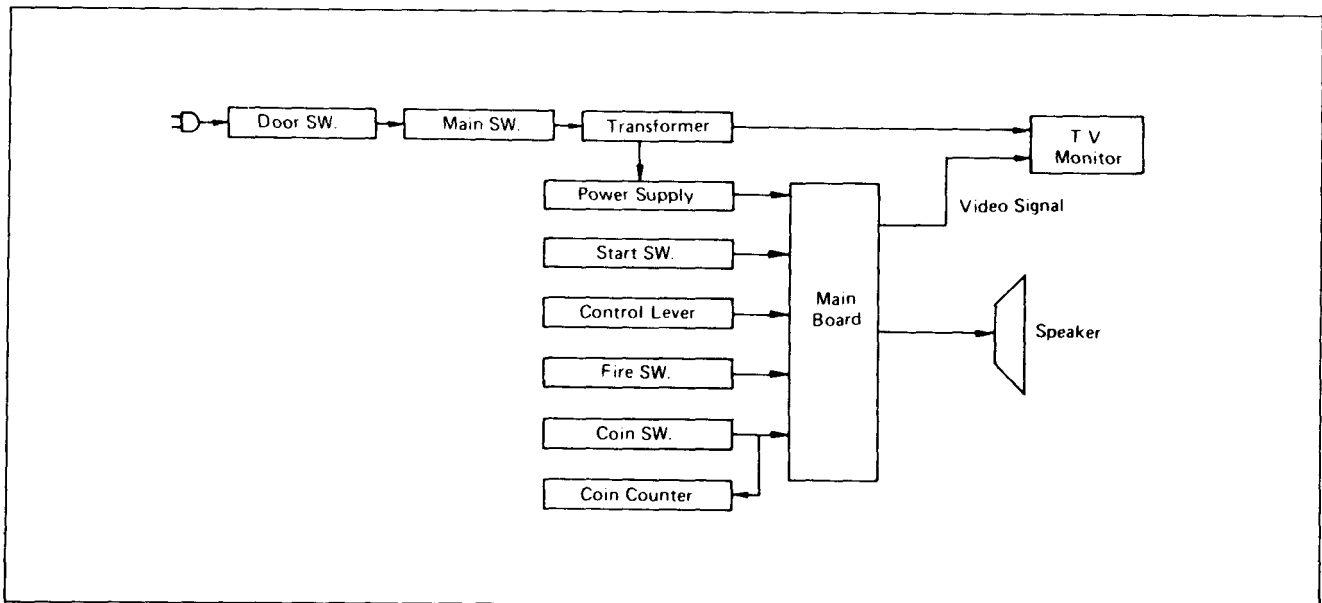

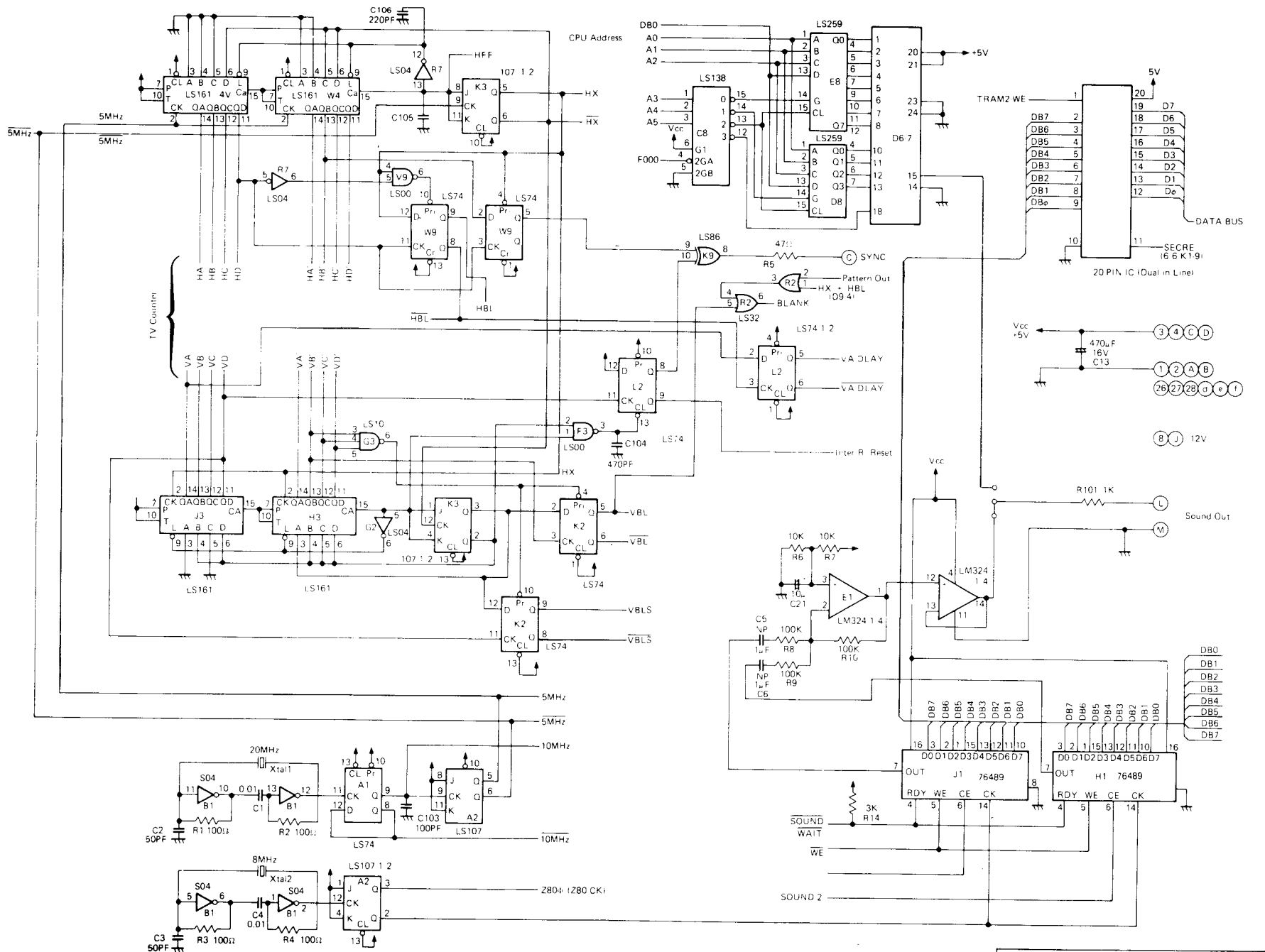

MR. DO!
8201

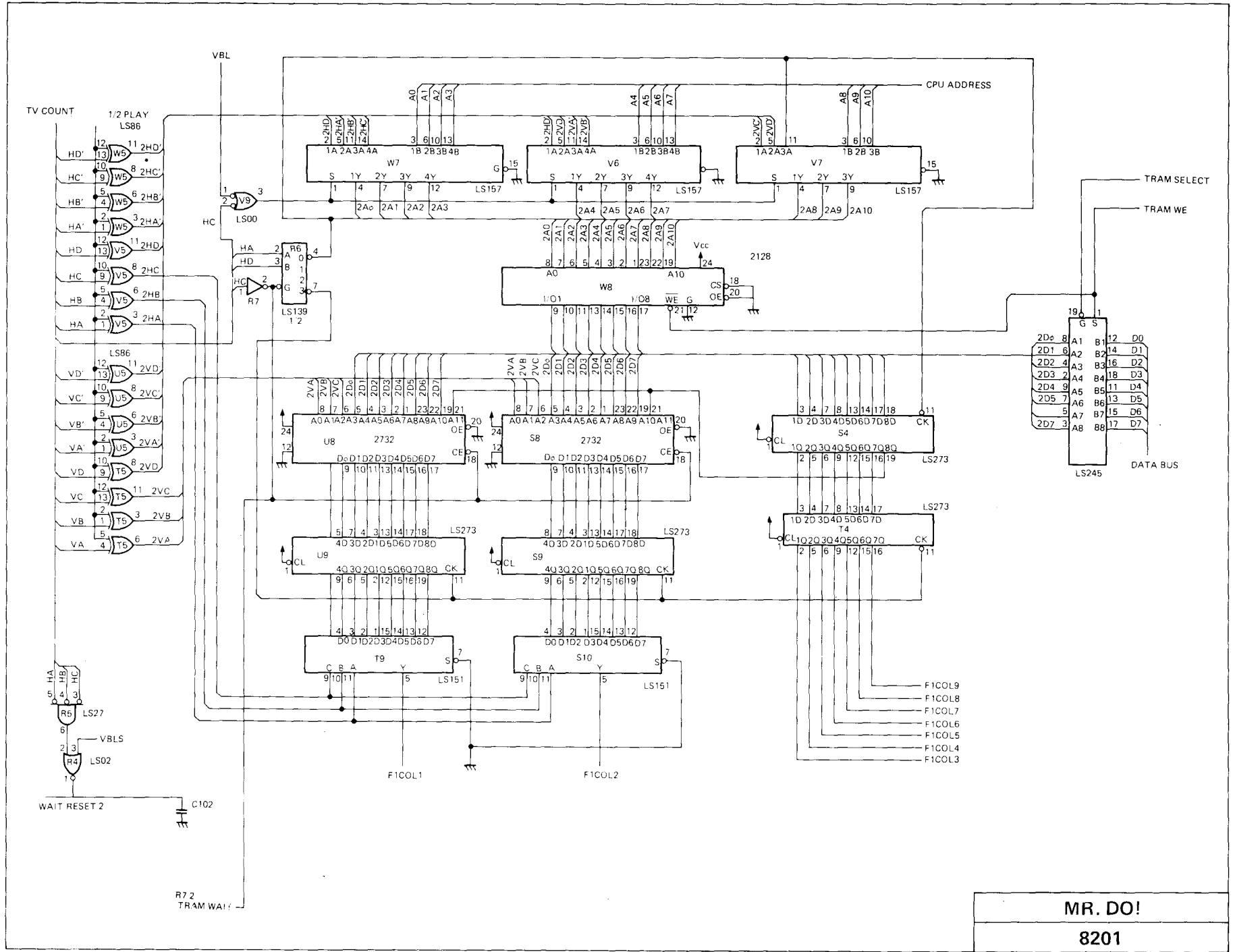

MR. DO!
8201

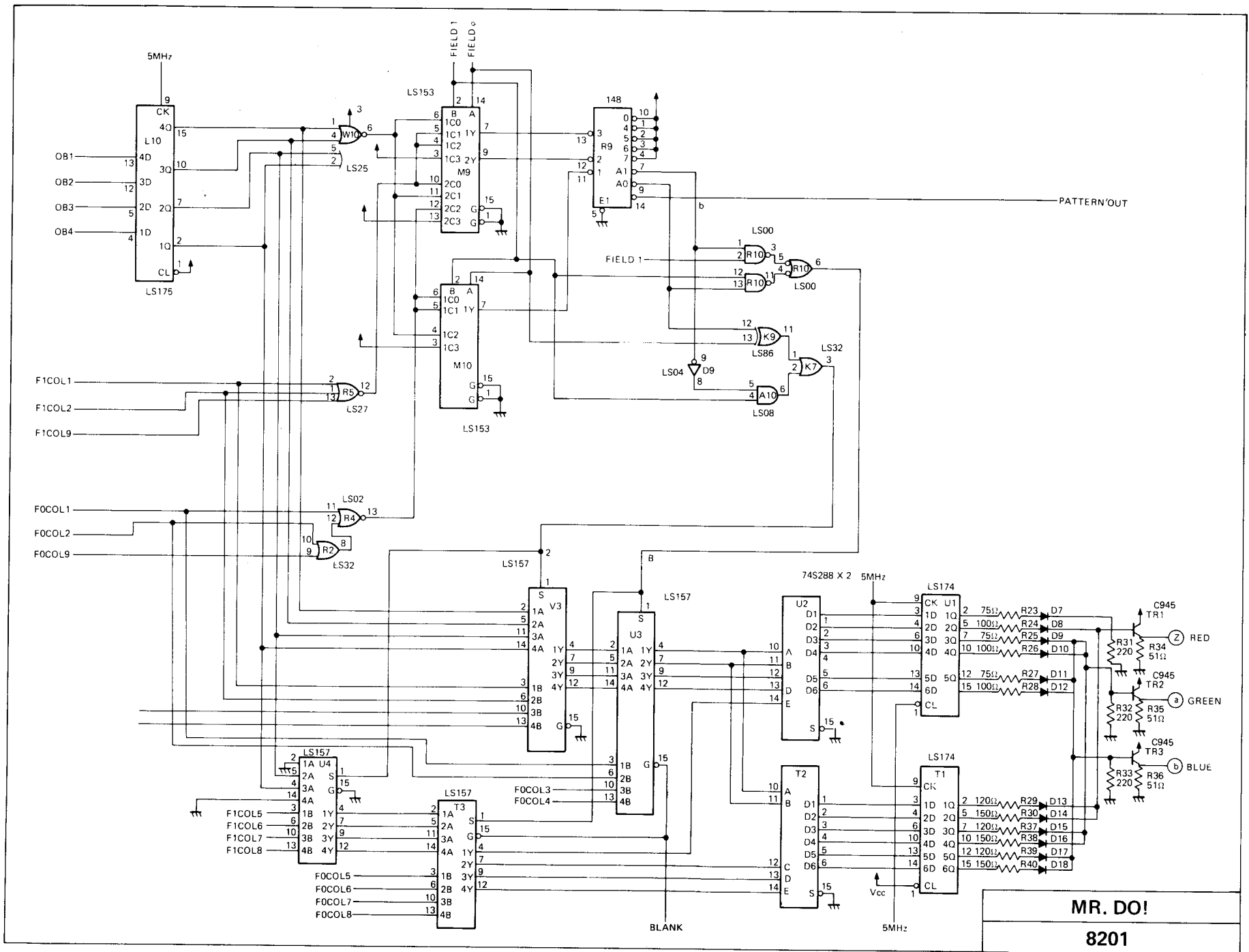

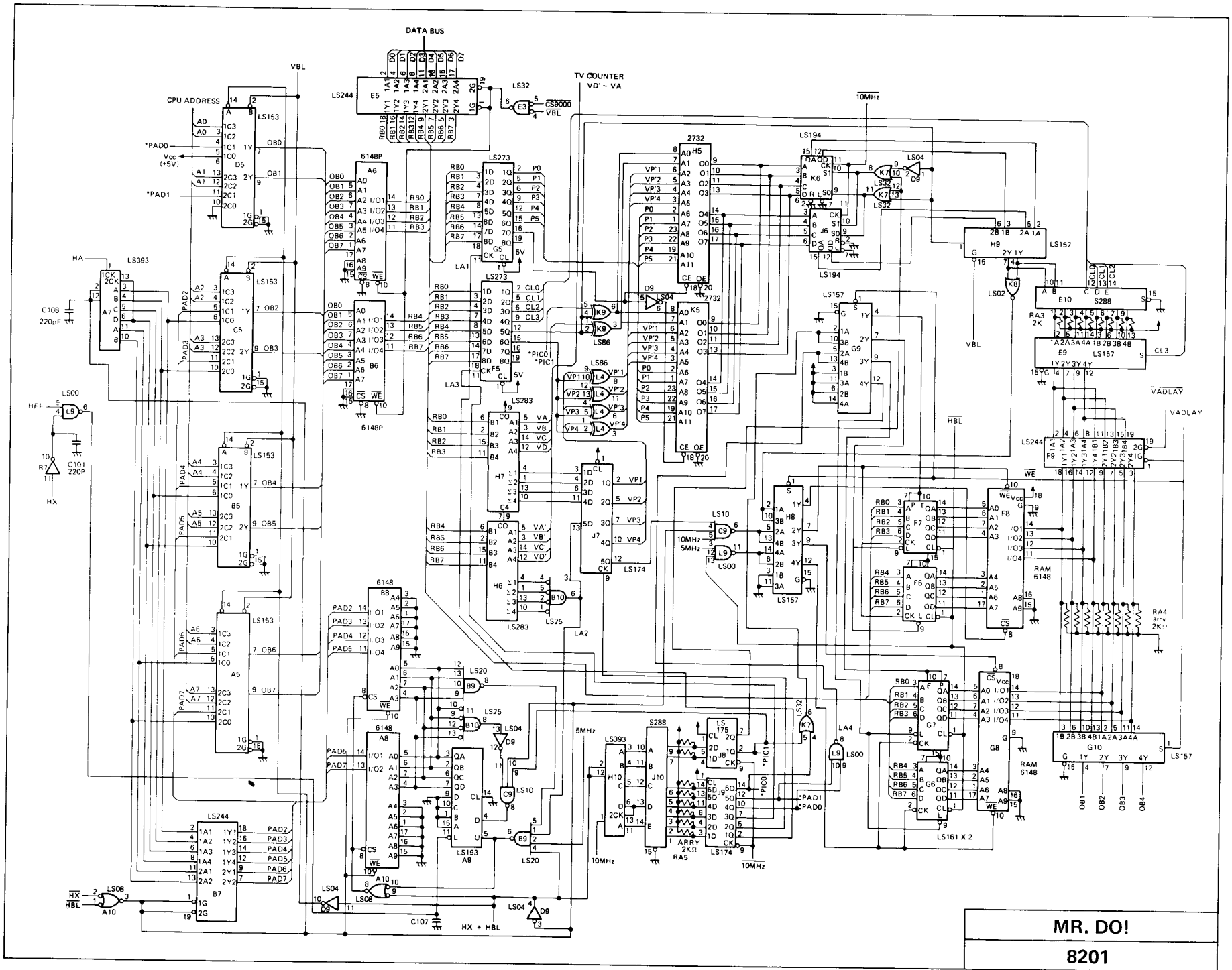

MR. DO!

8201

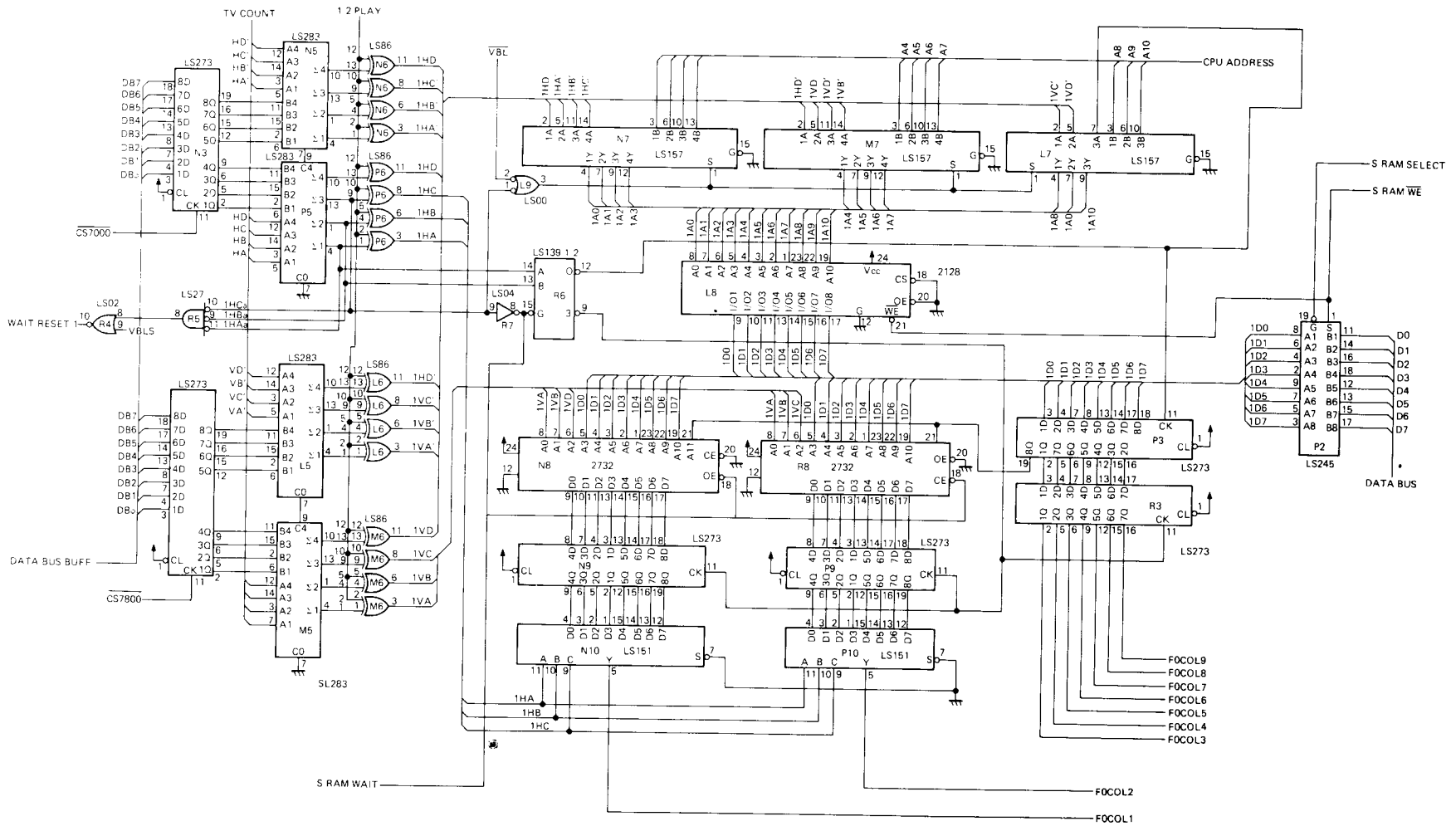

MR. DO!
8201

MAIN BLOCK DIAGRAM

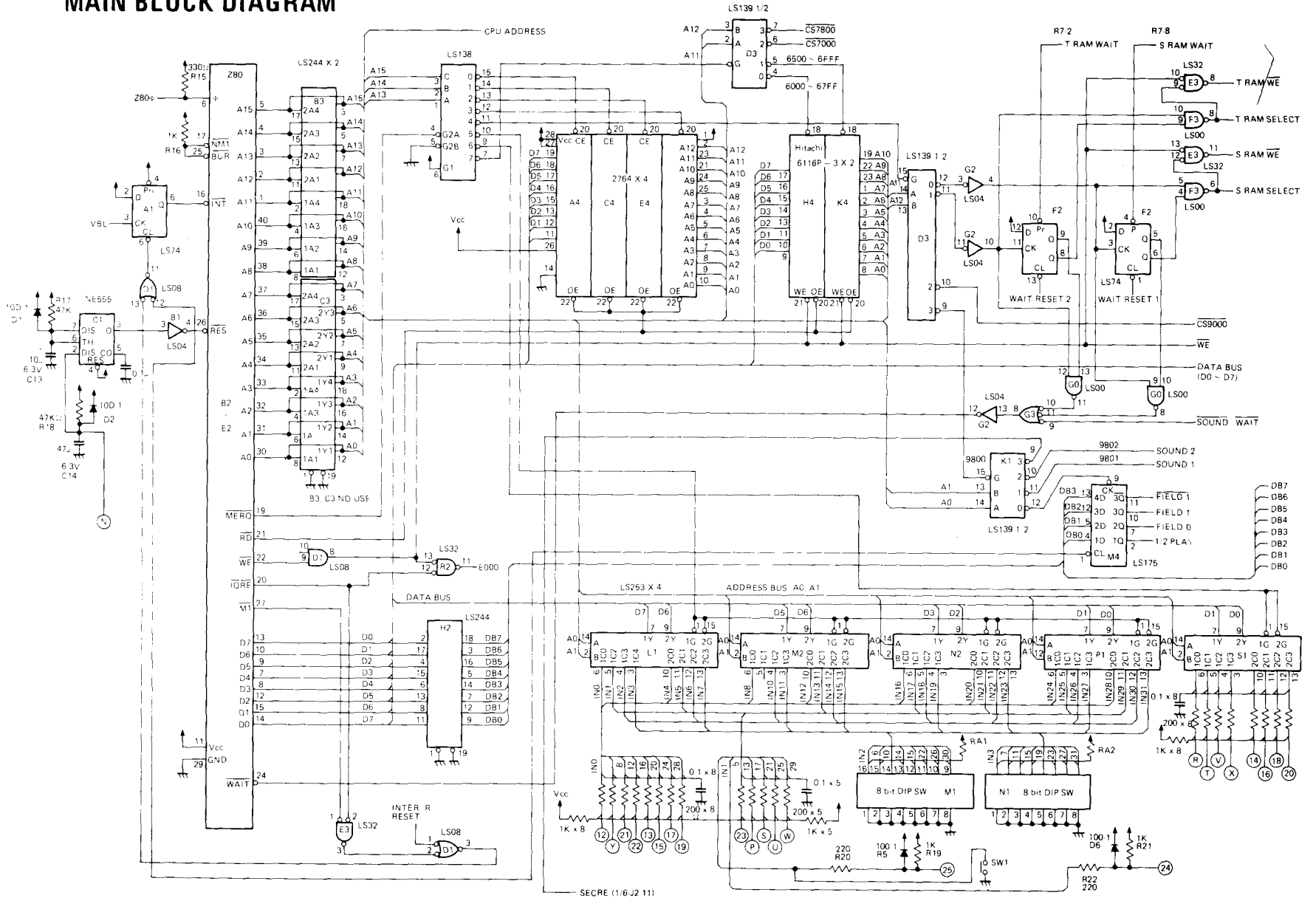

SECRE (1/6 J2 11)

MR. DO!
8201

SOUND AMPLIFIER DIAGRAM AND PARTS LOCATION

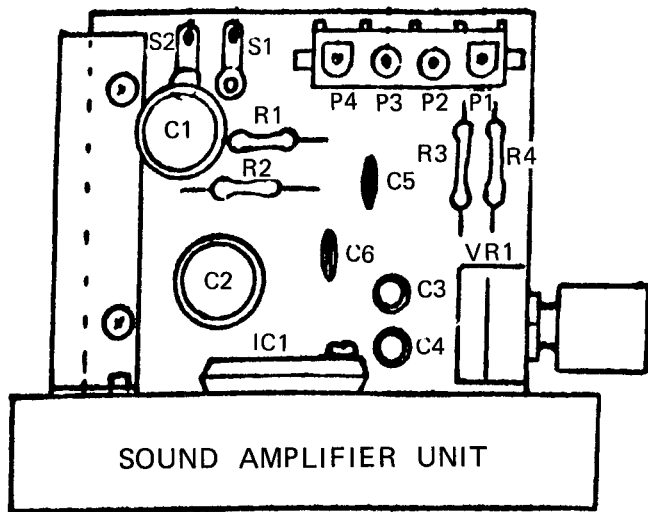
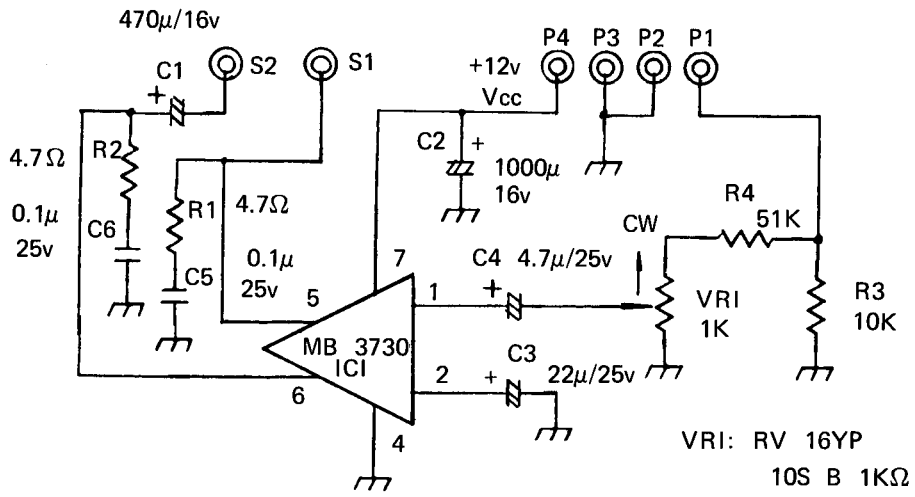

Mr. Do HARNESS PIN ASSIGNMENT

SOLDER SIDE

COMPONENT SIDE

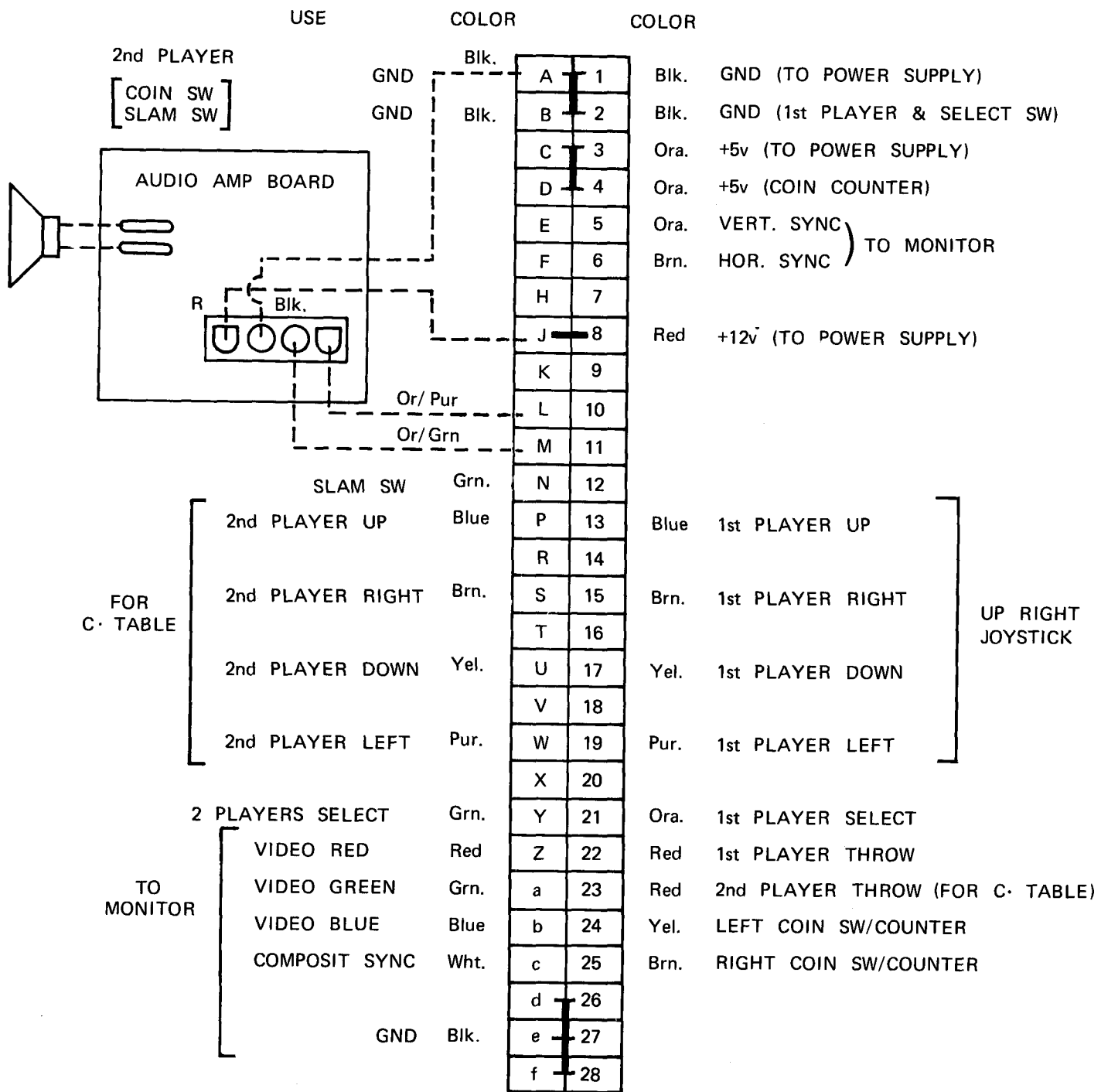

NOTE: CONNECTION FOR USE WITH ONE COIN COUNTER

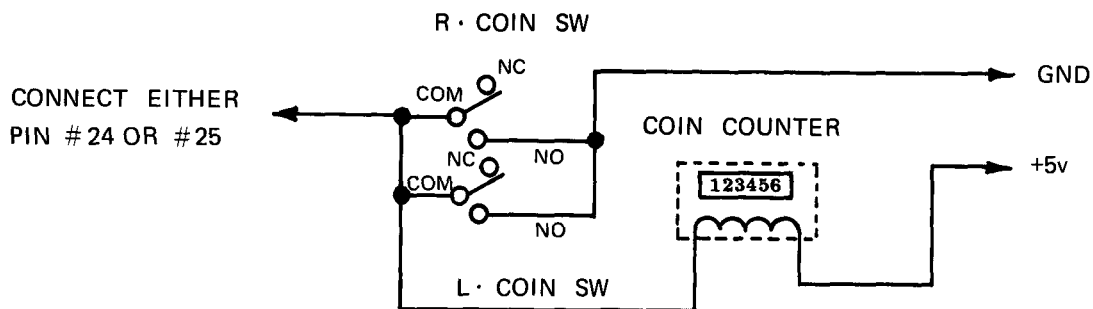

MODIFICATION FOR HORIZONTAL AND VERTICAL OUTPUT

Mr. Do P.C.B.

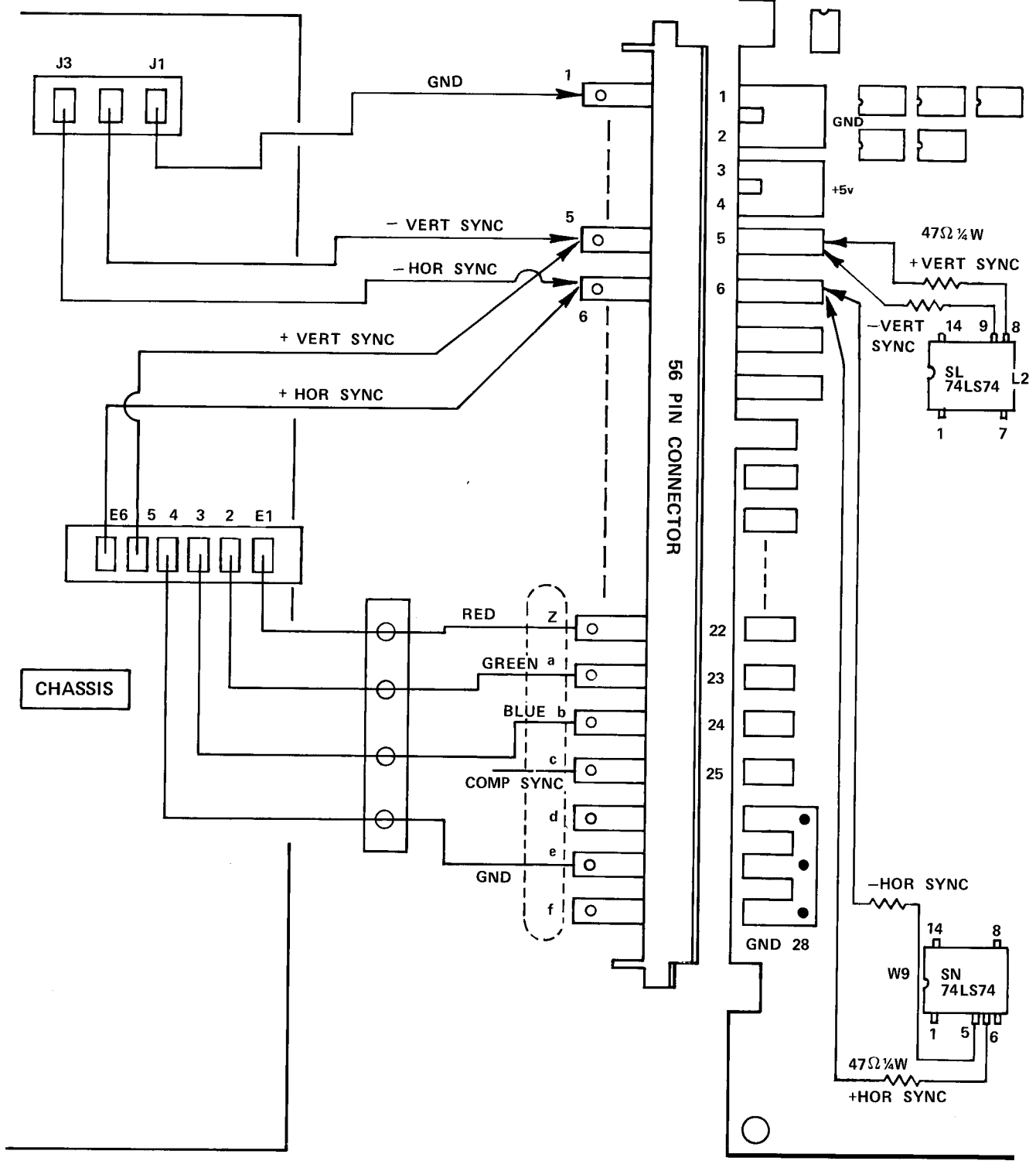

DEPENDING ON CHASSIS, USE ONE OF THE FOLLOWING MODIFICATIONS:

1. COMP SYNC
2. POSITIVE IND. SYNC
3. NEGATIVE IND. SYNC

BE SURE TO REMOVE COMP SYNC LINE WHEN INSTALLING EITHER THE POSITIVE OR NEGATIVE INDEPENDENT SYNC LINES.