

# BIRDIE-KING II

Schematics and Wiring Diagrams

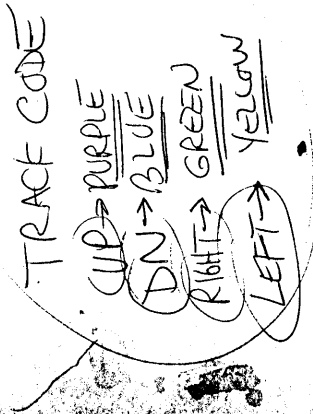

Distributed by:  
**MONROE Distributing Inc.**  
2999 Payne Avenue  
Cleveland, Ohio 44114  
Licensed by *Corn-It Co.*

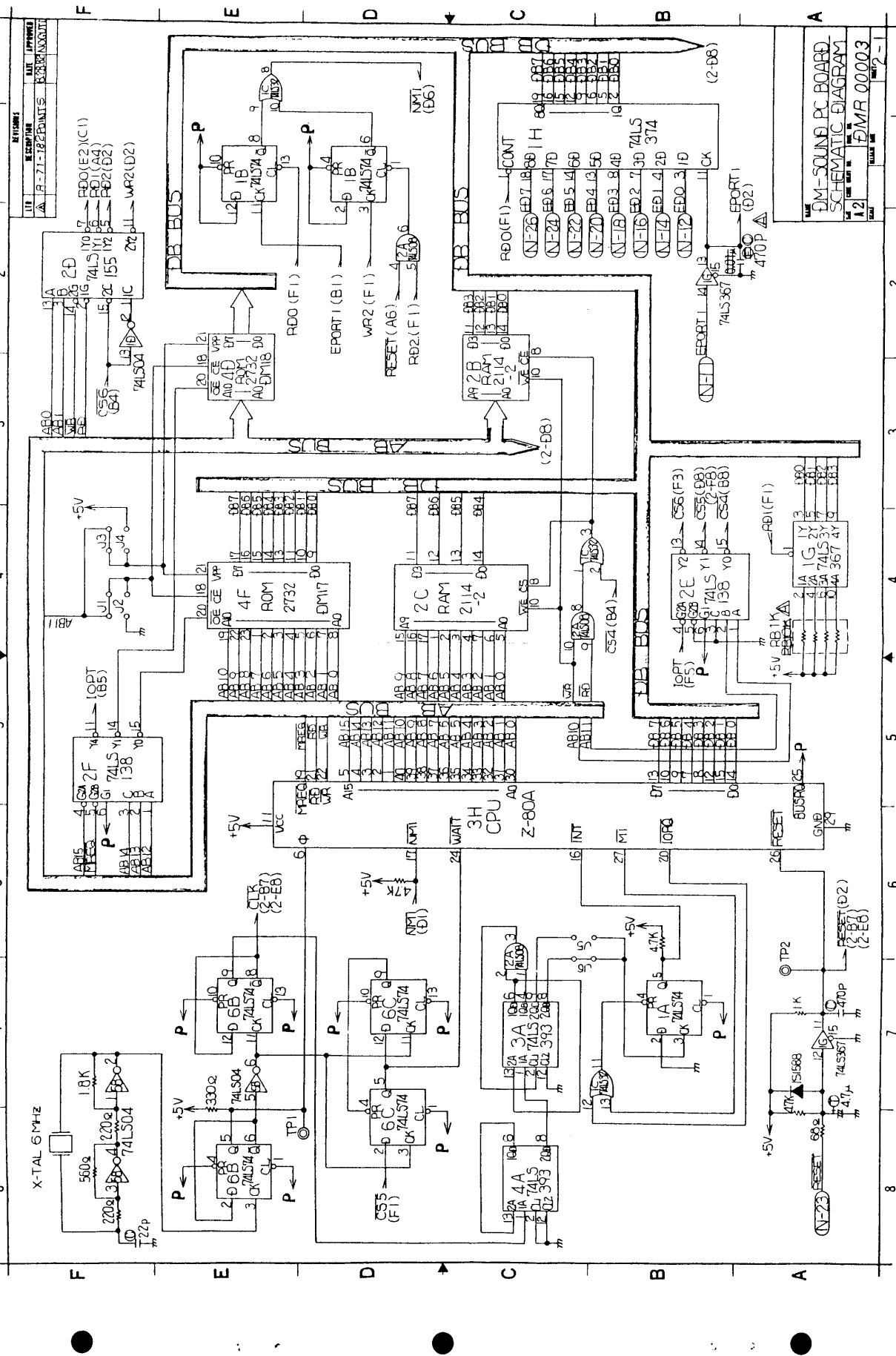

REVIEWS  
 DATE APPROVED  
 BY  
 A. A. ZI-182 PRINTS: 802/10/0017

DM-SOUND PC BOARD  
 SCHEMATIC DIAGRAM  
 FILE NO. 12  
 DATE 10/1/82  
 EMR 00003

F  
E  
D  
C  
B  
A

2  
3  
4  
5  
6  
7  
8

**18 PIN EDGE CONNECTOR**

| COMPONENT | SOLDER |                       |
|-----------|--------|-----------------------|
| GROUND    | 1      | A                     |
|           | 2      | B                     |
|           | 3      | C                     |
|           | 4      | D                     |
|           | 5      | E                     |
|           | 6      | F                     |
|           | 7      | H                     |
|           | 8      | J                     |
| +12       | 9      | K                     |
|           | 10     | L                     |
|           | 11     | M                     |
| +12       | 12     | N                     |
|           | 13     | P                     |
|           | 14     | R                     |
|           | 15     | S                     |
|           | 16     | T                     |
| +5        | 17     | U                     |
| +5        | 18     | V                     |
|           |        | TO 12 V. METER        |
|           |        | JUMPER -              |
|           |        | PURPLE                |
|           |        | W/RED                 |
|           |        | W/RED                 |
|           |        | RED                   |
|           |        | +5V. TO TRAKBALL ASSY |

NOTE: Some wire colors may vary.

**22 PIN EDGE CONNECTOR**

| COMPONENT               | SOLDER |                 |
|-------------------------|--------|-----------------|
| GROUND                  | 1      | A               |
| VIDEO                   | 2      | B               |
| VIDEO                   | 3      | C               |
| VIDEO SYNC              | 4      | D               |
| (SPEAKER) SOUND         | 5      | E               |
|                         | 6      | F               |
|                         | 7      | H               |
| COIN SWITCH             | 8      | J               |
| RETURN FROM 12 V. METER | 9      | K               |
|                         | 10     | L               |
| 1 PLAYER START          | 11     | M               |
| UP                      | 12     | N               |
| DOWN                    | 13     | P               |
| RIGHT                   | 14     | R               |
| LEFT                    | 15     | S               |
|                         | 16     | T               |
|                         | 17     | U               |
|                         | 18     | V               |
|                         | 19     | W               |
|                         | 20     | X               |
|                         | 21     | Y               |
|                         | 22     | Z               |
|                         |        | BLACK           |
|                         |        | RED             |
|                         |        | GREEN           |
|                         |        | YELLOW          |
|                         |        | GRAY +          |
|                         |        | W/ORANGE        |
|                         |        | ORANGE          |
|                         |        | BLUE            |
|                         |        | BROWN           |
|                         |        | YELLOW          |
|                         |        | GREEN           |
|                         |        | W/BLACK         |
|                         |        | W/YELLOW        |
|                         |        | BLACK           |
|                         |        | BLUE            |
|                         |        | GRAY-           |
|                         |        | (SPEAKER) SOUND |
|                         |        | VIDEO GROUND    |
|                         |        | VIDEO           |
|                         |        | TILT SWITCH     |
|                         |        | 2 PLAYER START  |

NOTE: Some wire colors may vary.

Adjustments of DIP Switch  
(Before adjusting, turn the power switch off.)

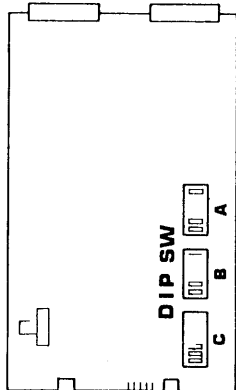

Figure 7

DIP Switch (A)

| Setting                                      | Position  |     |   |   |     |     |     |     |  |
|--|-----------|-----|---|---|-----|-----|-----|-----|--|
|  | 1         | 2   | 3 | 4 | 5   | 6   | 7   | 8   |  |
| * Par Play                                   | 0 Hole    |     |   |   |     |     |     |     |  |
| * Birdie                                     | 1 Hole    |     |   |   |     |     |     |     |  |
| * Eagle                                      | 2 Holes   | ON  |   |   |     |     |     |     |  |
| * Double Eagle                               | 4 Holes   |     |   |   |     |     |     |     |  |
| Par Play                                     | 1 Hole    |     |   |   |     |     |     |     |  |
| Birdie                                       | 2 Holes   |     |   |   |     |     |     |     |  |
| Eagle  | 3 Holes   | OFF |   |   |     |     |     |     |  |
| Double Eagle                                 | 4 Holes   |     |   |   |     |     |     |     |  |
| Hole in One                                  | 3 Holes   |     |   |   |     |     |     |     |  |
| Hole in One                                  | 9 Holes   | ON  |   |   |     |     |     |     |  |
| Free Play                                    | Free Play | OFF |   |   |     |     |     |     |  |
|  | Normal    | ON  |   |   |     |     |     |     |  |
| Number of Holes Per Play                     | 9         |     |   |   | ON  | ON  |     |     |  |
|  | 5         |     |   |   | ON  | OFF |     |     |  |
|  | 4         |     |   |   | OFF | ON  |     |     |  |
|  | 3         |     |   |   | OFF | OFF |     |     |  |
| Screen Inversion (Upright Type Machine Only) |           |     |   |   |     |     | ON  |     |  |
| Game Style                                   | Upright   |     |   |   |     |     | OFF |     |  |
|  | Table     |     |   |   |     |     |     | ON  |  |
|  |           |     |   |   |     |     |     | OFF |  |

Factory Adjustment: \*

| Setting           | Position | 1 WAY (LEFT) |     |     |     | 2 WAY (RIGHT) |     |     |    |
|-------------------|----------|--------------|-----|-----|-----|---------------|-----|-----|----|
|                   |          | 1            | 2   | 3   | 4   | 5             | 6   | 7   | 8  |
| * 1 Coin - 1 Play |          | ON           | ON  | ON  | ON  | ON            | ON  | ON  | ON |
| 1 Coin - 2 Plays  |          | OFF          |     |     |     |               |     |     |    |
| 1 Coin - 3 Plays  |          | ON           | OFF |     |     | ON            | OFF |     |    |
| 1 Coin - 4 Plays  |          | OFF          |     |     |     |               |     |     |    |
| 1 Coin - 5 Plays  |          | ON           | ON  | OFF | OFF | ON            | ON  | OFF |    |
| 1 Coin - 6 Plays  |          | OFF          |     |     |     |               |     |     |    |
| 1 Coin - 7 Plays  |          | ON           | OFF |     |     | ON            | OFF |     |    |
| 1 Coin - 8 Plays  |          | OFF          |     |     |     |               |     |     |    |
| 2 Coins - 1 Play  |          | ON           | ON  | ON  | OFF | ON            | ON  | OFF |    |
| 3 Coins - 1 Play  |          | OFF          |     |     |     |               |     |     |    |
| 4 Coins - 1 Play  |          | ON           | OFF |     |     | ON            | OFF |     |    |
| 5 Coins - 1 Play  |          | OFF          |     |     |     |               |     |     |    |
| 6 Coins - 1 Play  |          | ON           | ON  | OFF | OFF | ON            | ON  | OFF |    |
| 7 Coins - 1 Play  |          | OFF          |     |     |     |               |     |     |    |
| 8 Coins - 1 Play  |          | ON           | OFF |     |     | ON            | OFF |     |    |
| 9 Coins - 1 Play  |          | OFF          |     |     |     |               |     |     |    |

| Setting   |  | Position |  | 1   | 2   | 3   | 4   | 5   | 6 | 7   | 8 |     |  |  |  |  |
|---|--|----------|--|-----|-----|-----|-----|-----|---|-----|---|-----|--|--|--|--|
| Appearance of Crow *  | Without                                    |          |  | ON  |     |     | OFF |     |   |     |   |     |  |  |  |  |
|   | With                                       |          |  | OFF |     |     |     |     |   |     |   |     |  |  |  |  |
| The hole from which a crow appears and flies with drawing a circle or a 8-shape in the air. * | Circle 1,7,11,15,18<br>8-shape 3,5,9,13,17 |          |  |     | ON  | ON  |     |     |   |     |   | OFF |  |  |  |  |
|   | Circle 4,7,13,18<br>8-shape 1,10,16,17     |          |  |     | ON  | OFF |     |     |   |     |   |     |  |  |  |  |
|   | Circle 1,10,16,18<br>8-shape 4,7,13,17     |          |  |     | OFF | ON  |     |     |   |     |   |     |  |  |  |  |
|   | Circle 3,5,9,13,18<br>8-shape 1,7,11,15,17 |          |  |     | OFF | OFF |     |     |   |     |   |     |  |  |  |  |
| Coin Display *  | No Display                                 |          |  |     |     |     |     | ON  |   |     |   |     |  |  |  |  |
|   | Display                                    |          |  |     |     |     |     | OFF |   |     |   |     |  |  |  |  |
| Year Display *  | No Display                                 |          |  |     |     |     |     |     |   | ON  |   |     |  |  |  |  |
|   | Display                                    |          |  |     |     |     |     |     |   | OFF |   |     |  |  |  |  |
| Check *   | Check                                      |          |  |     |     |     |     |     |   | ON  |   |     |  |  |  |  |
|   | Normal                                     |          |  |     |     |     |     |     |   | OFF |   |     |  |  |  |  |
| Coin System *   | 1 Way                                      |          |  |     |     |     |     |     |   | ON  |   |     |  |  |  |  |
|   | 2 Way                                      |          |  |     |     |     |     |     |   | OFF |   |     |  |  |  |  |

. Factory Adjustment: \*

| REV | DESCRIPTION | DATE | APPROVED |
|-----|-------------|------|----------|
|     |             |      |          |

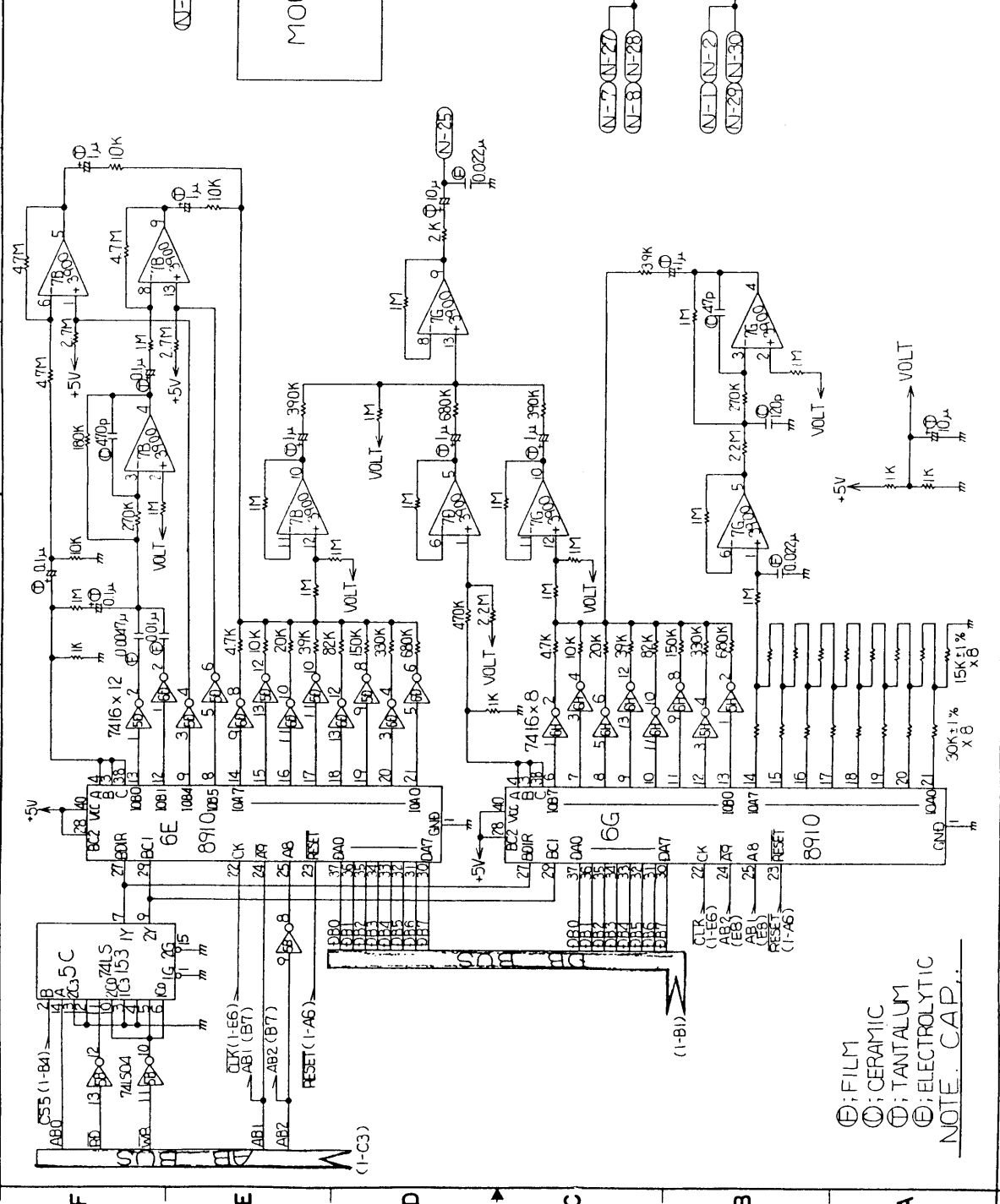

⊕; FILM  
 ⊙; CERAMIC  
 ⊕; TANTALUM  
 ⊕; ELECTROLYTIC  
 NOTE: CAP.

DM-SOUND PC BOARD  
 SCHEMATIC DIAGRAM  
 12  
 DMR 00003  
 REV 2-2

F  
 E  
 D  
 C  
 B  
 A

1 2 3 4 5 6 7 8

| REVISIONS |                 |               |
|-----------|-----------------|---------------|
| CTR       | DESCRIPTION     | DATE APPROVED |
| A         | 2 POINT S-71-15 | 17-8882       |
|           |                 | 10060041      |

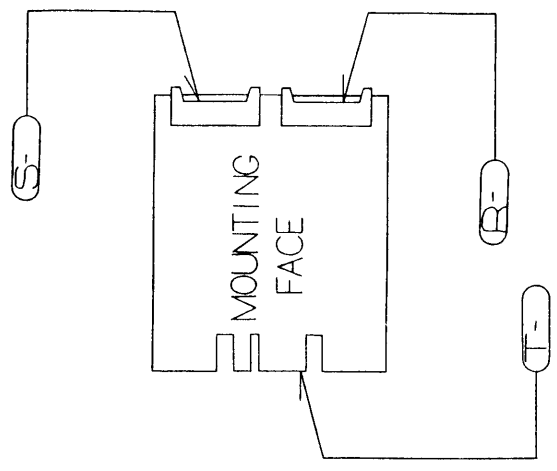
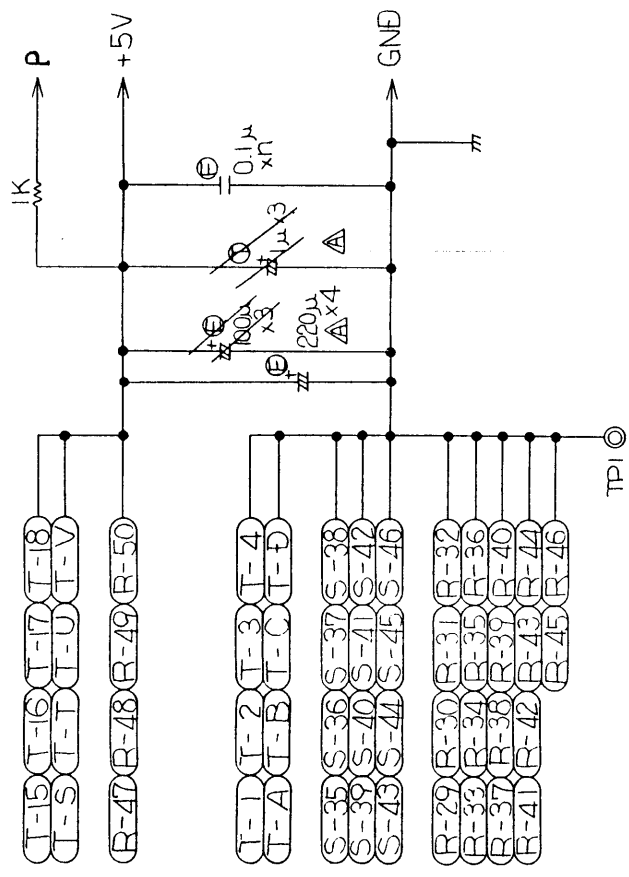

- ⊖ ; ELECTROLYTIC
- ⊕ ; TANTALUM
- ⊖ ; FILM
- ⊙ ; CERAMIC

NOTE. CAP.

|       |                 |           |      |
|-------|-----------------|-----------|------|
| NAME  | EM-CPU PC BOARD |           |      |
| SIZE  | FORM NO.        | REV. NO.  | DATE |
| A 3   |                 | DMR 00002 | 5-5  |
| SCALE | RELEASE DATE    |           |      |

| REV | DESCRIPTION | DATE APPROVED |
|-----|-------------|---------------|
|     |             |               |

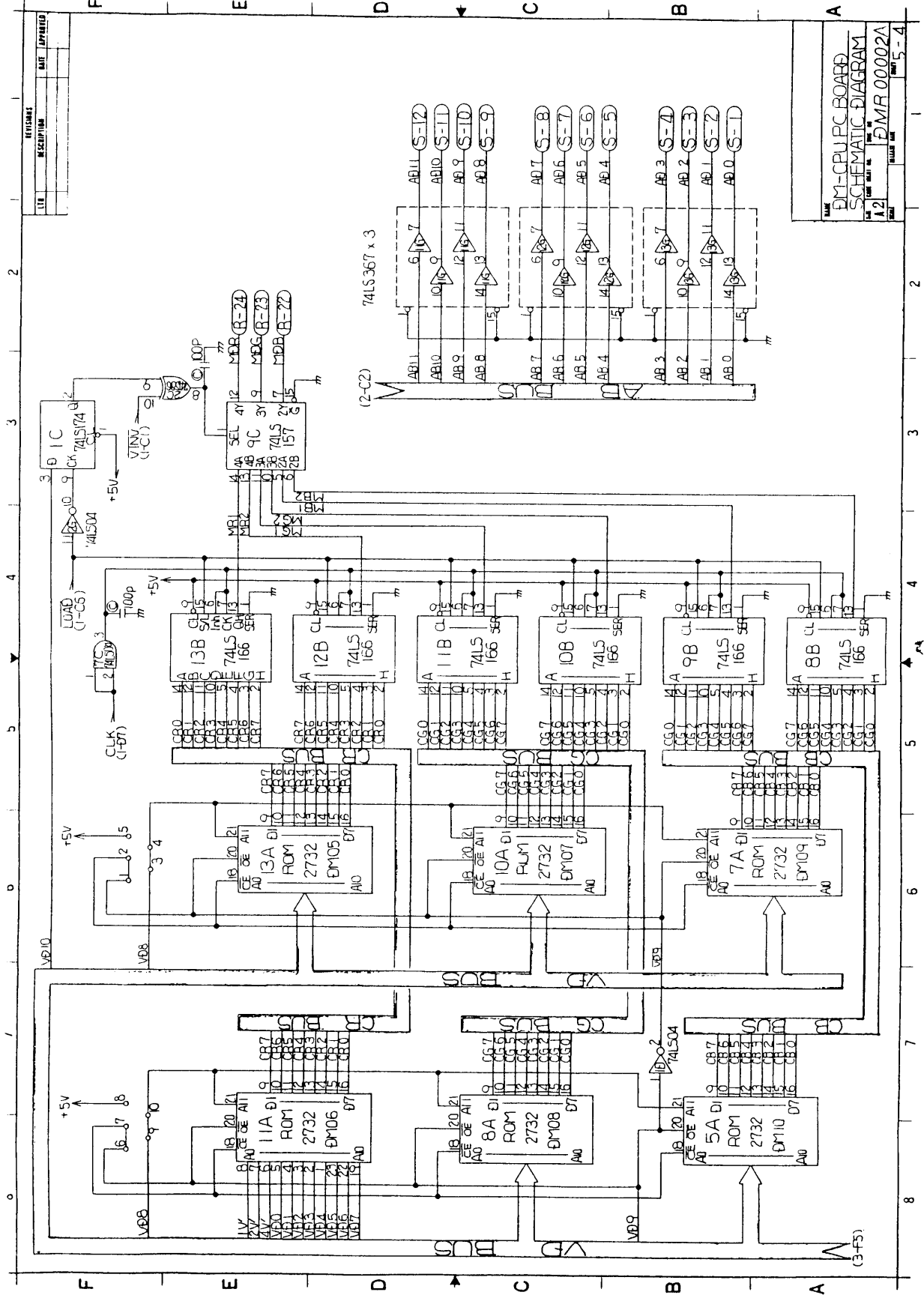

EM-CPU PC BOARD  
SCHEMATIC DIAGRAM  
EMR 00002A  
REV 5-4

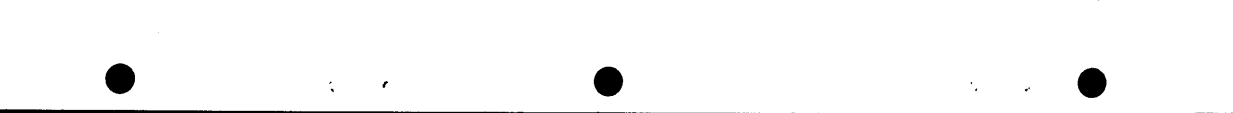
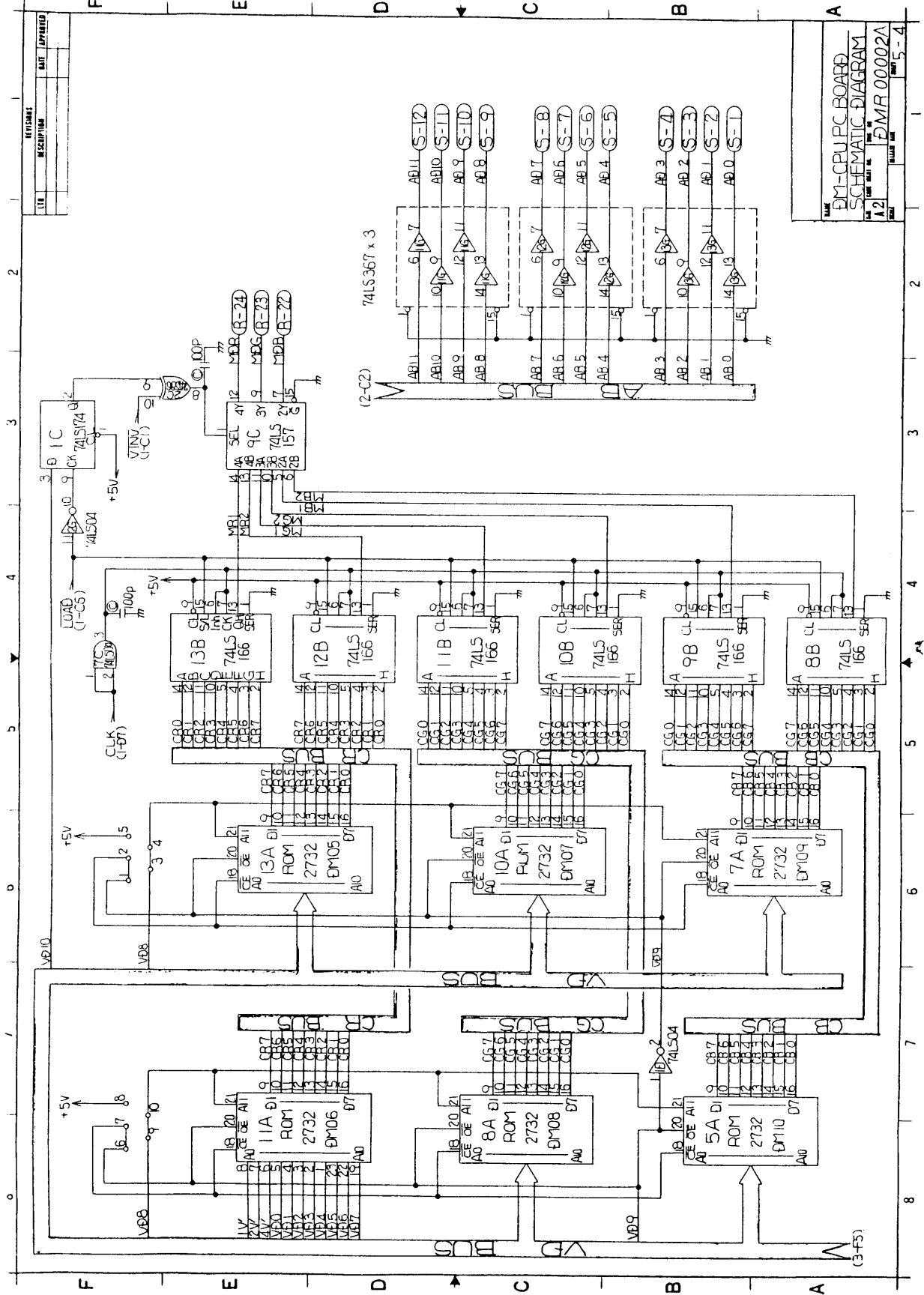

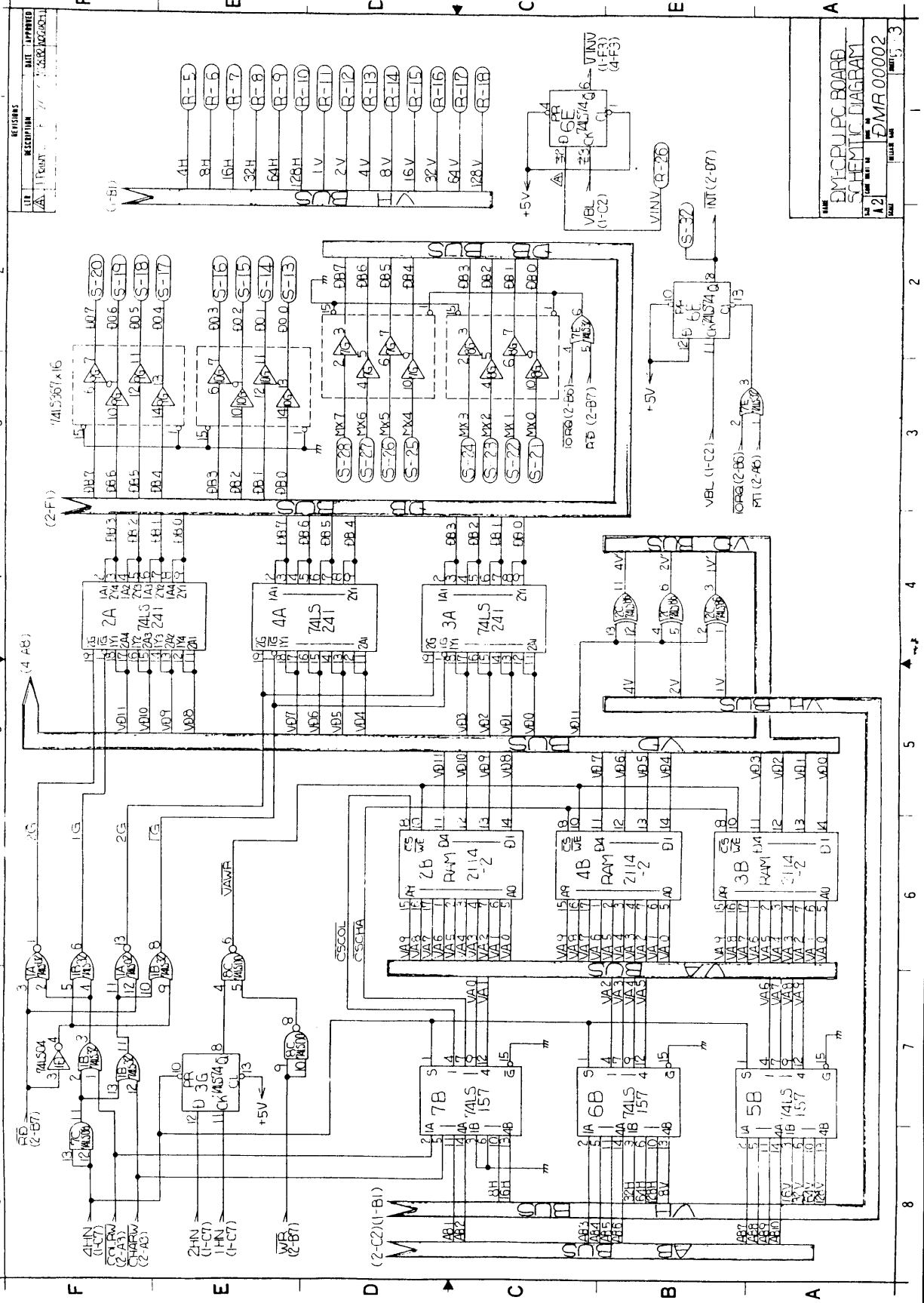

| REV | DESCRIPTION | DATE     | APPROVED    |
|-----|-------------|----------|-------------|
| 1   | INITIAL     | 11/11/81 | [Signature] |

| NAME              | DATE     | REV |
|-------------------|----------|-----|
| DM-CPU-PC BOARD   | 11/11/81 | 1   |
| SCHEMATIC DIAGRAM |          |     |
| DMR 00002         |          |     |



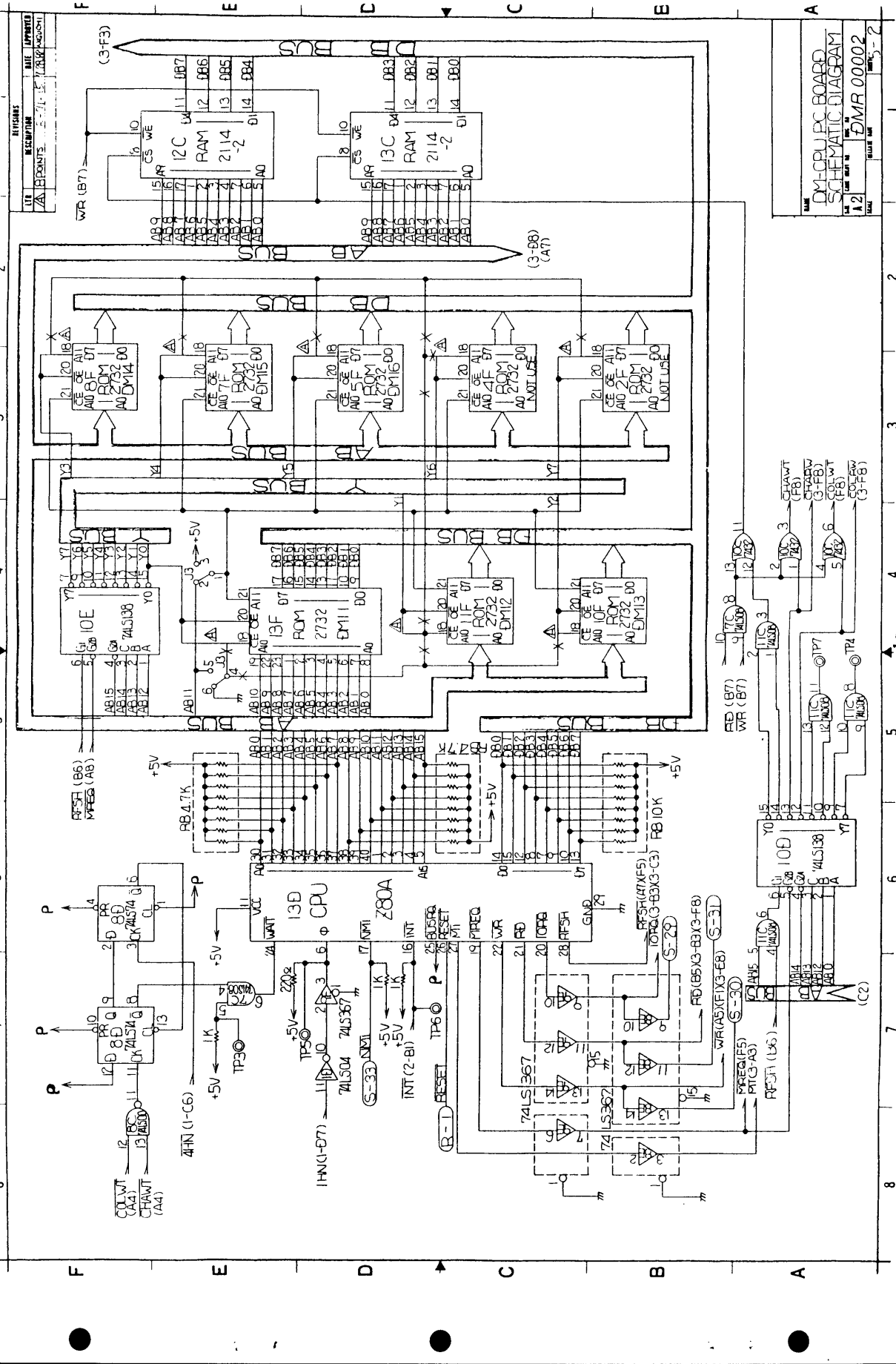

NUCSARS  
 U1A DESCRIPTION: 8086  
 U2A DESCRIPTION: 2716  
 U3A DESCRIPTION: 2114  
 U4A DESCRIPTION: 2114  
 U5A DESCRIPTION: 2716

DM-CPU PC BOARD  
 SCHEMATIC DIAGRAM  
 1.2  
 DATE: 11/85  
 DMR 00002  
 REV: 1-2

8 7 6 5 4 3 2 1

F E D C B A

| REV | DESCRIPTION | DATE | APPROVED |
|-----|-------------|------|----------|
|     |             |      |          |

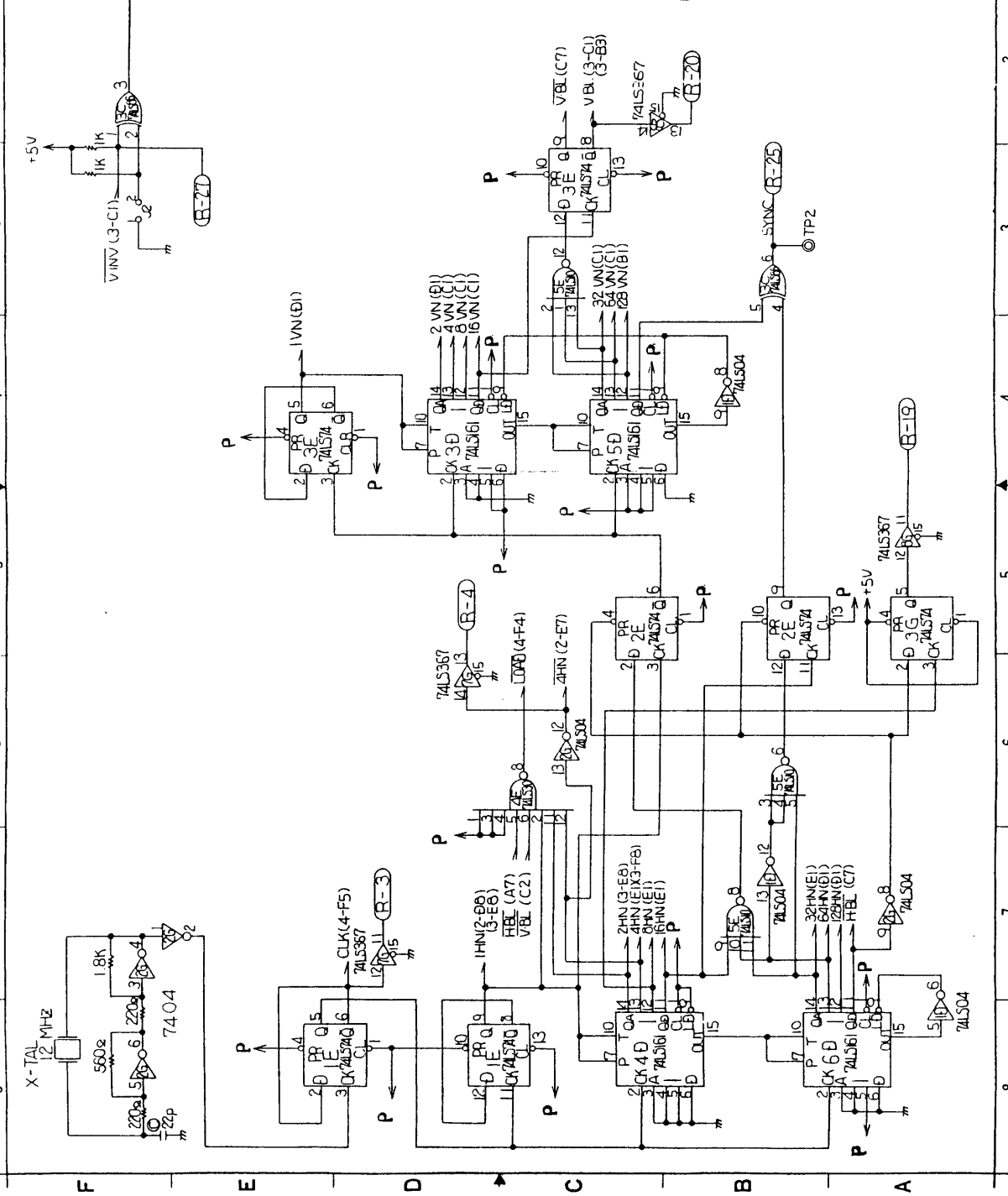

FM-CPU PCB BOARD  
 SCHEMATIC DIAGRAM  
 DATE: 1988.08.22  
 DRAWN BY: FMR 00002A  
 SHEET NO: 5-1



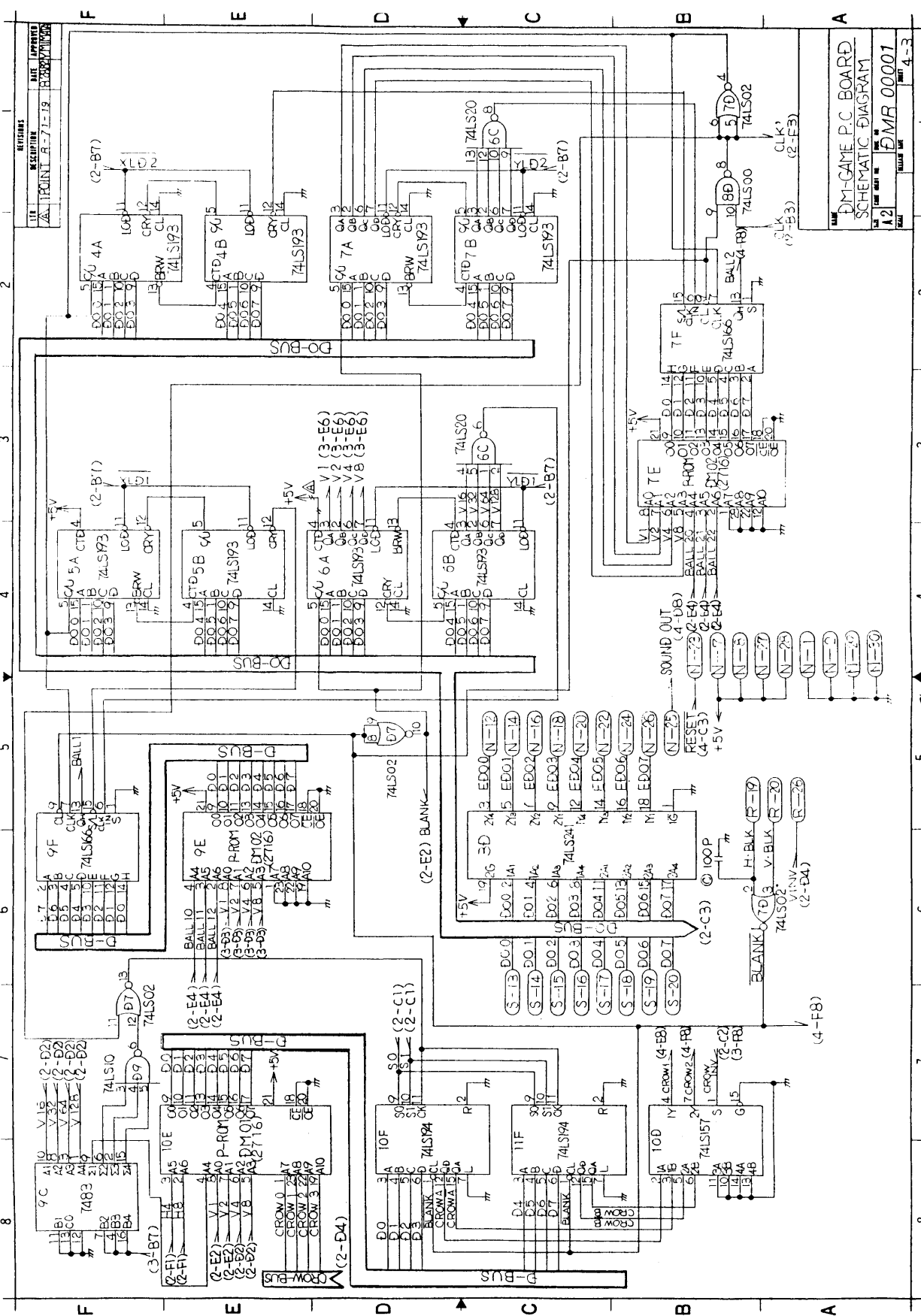

REVIEWS  
 DATE APPROVED  
 DATE  
 100 POINTS - 7-19  
 12

DM-GAME P.C. BOARD  
 SCHEMATIC DIAGRAM  
 DMR 00001  
 Rev. 4-3

2

3

4

5

6

7

8

F

E

D

C

B

A

F

E

D

C

B

A





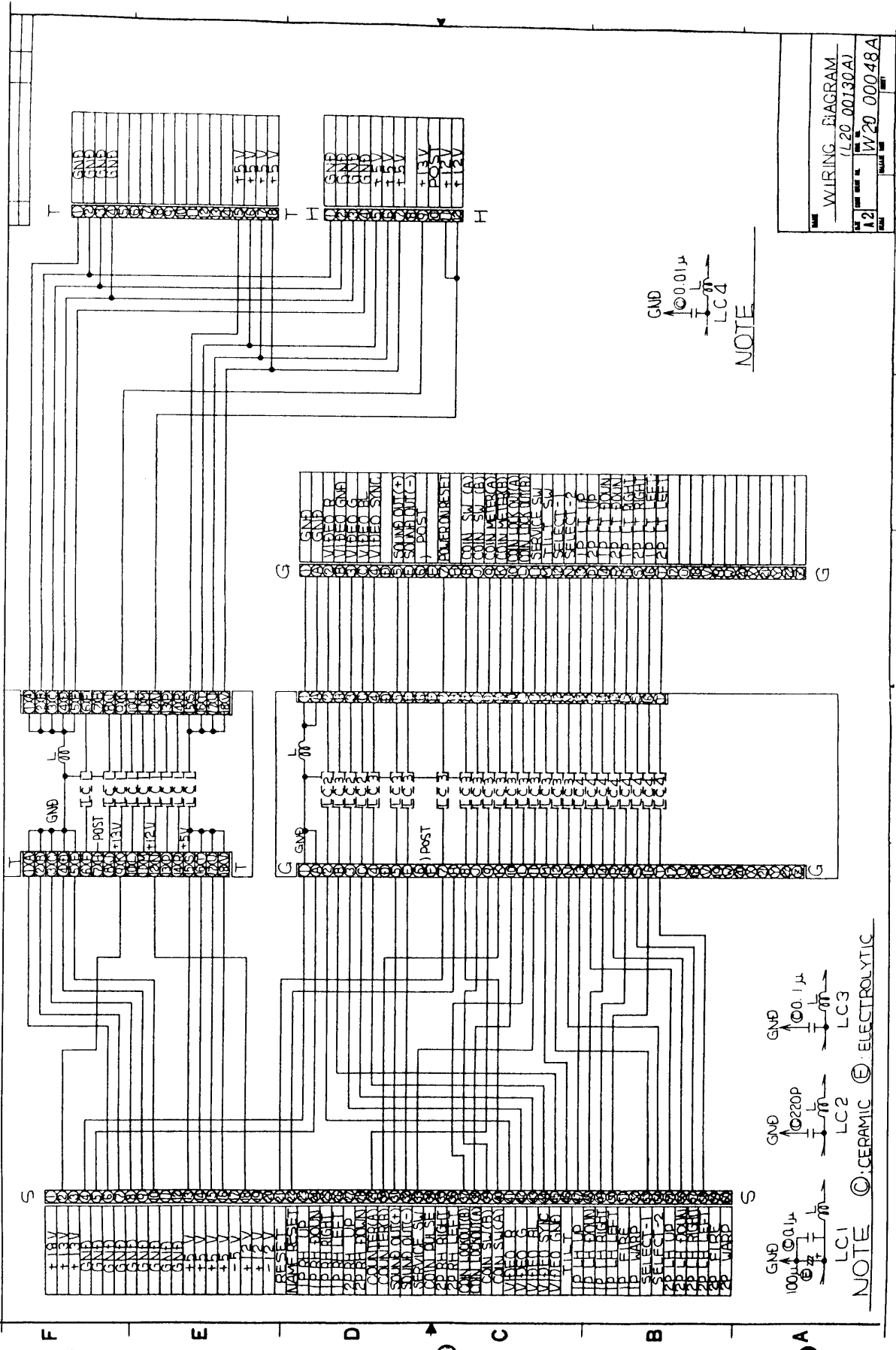

WIRING DIAGRAM  
 (L20 00130A)  
 W20 00048A

NOTE  
 GND  
 100.001μ  
 LC4

NOTE  
 100.001μ  
 LC1  
 GND  
 10220P  
 LC2  
 GND  
 100.1μ  
 LC3  
 NOTE © CERAMIC Ⓞ ELECTROLYTIC