

1072

The Leland
CORPORATION

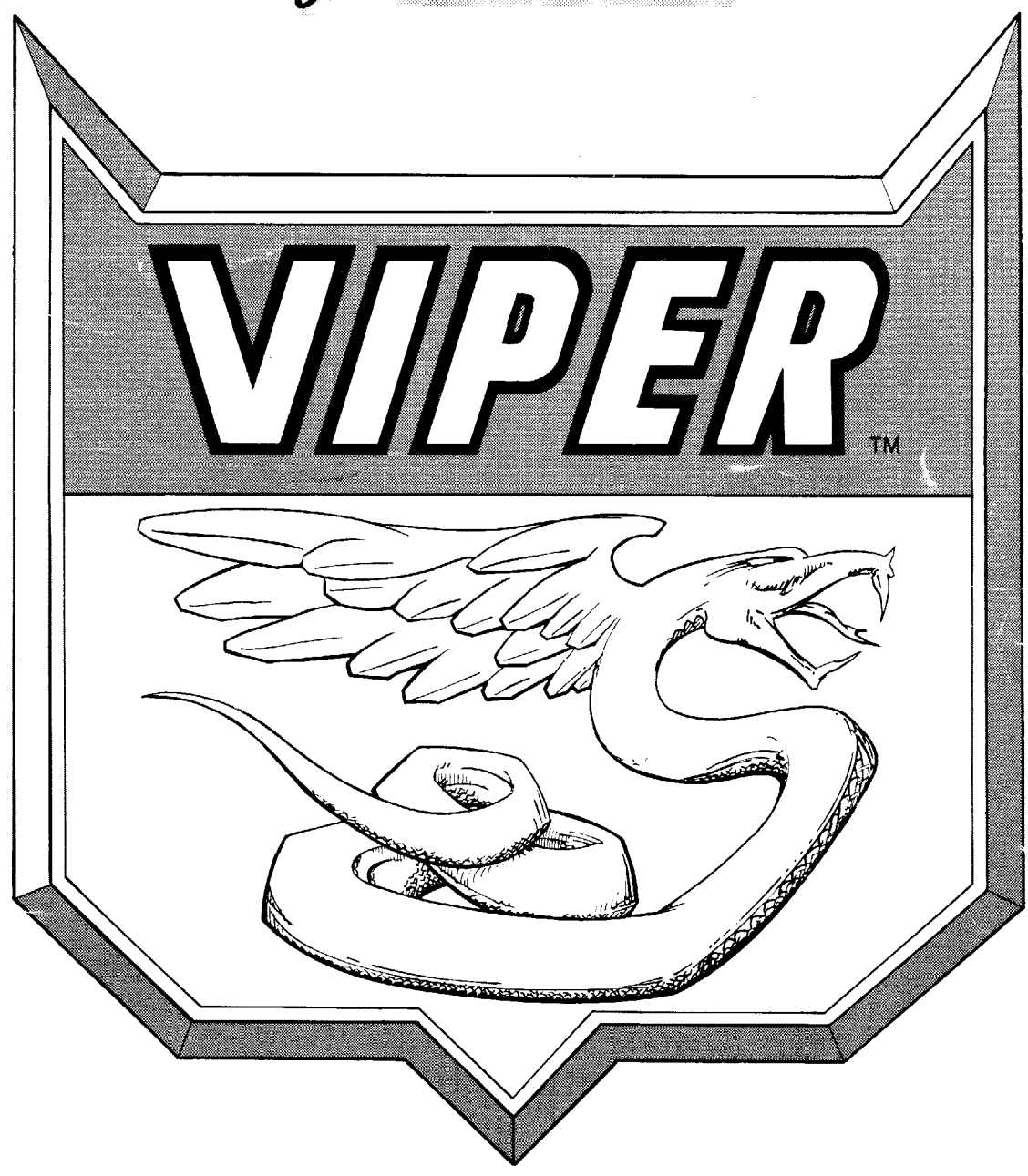

**SERVICE & INSTALLATION
MANUAL**

FCC WARNING

This equipment generates, uses, and can radiate radio frequency energy and if not installed in accordance with the instructions manual, may cause interference to radio communications. It has been tested and found to comply with the limits for a class "A" computing device pursuant to subpart "J" of part 15 of the FCC rules, which are designed to provide reasonable protection against such interference when operated in a commercial environment. Operation of this equipment in a residential area is likely to cause interference, in which case the user, at his own expense, will be required to correct the interference.

NON-LELAND REPLACEMENT PARTS NOTICE

The Leland Corporation recommends the use of only Leland Corp. parts when replacing any malfunctioning component or assembly in your video amusement machine. For safety and reliability, the Leland Corp. does not recommend or authorize any substitute parts or modifications of Leland Corp. equipment. Such alterations may adversely affect game play or cause serious injury, and *will* void your warranty. Unauthorized parts, modifications and non-Leland Corp. game conversion parts may also void FCC compliance.

OPTIMIZE YOUR PROFITS

Our research shows that a two minute quarter both satisfies the player and keeps the quarters flowing. This game is equipped with a very sophisticated diagnostics program. Refer to your Diagnostics Manual to set your game for maximum appeal and profit.

MACHINE INFORMATION: PURCHASE DATE: _____/_____/_____

DISTRIBUTOR: _____

GAME NAME: _____

SERIAL NUMBERS _____ PROGRAM: _____

MAIN BOARD: _____ I/O BOARD: _____

EXPANSION BOARD: _____ CABINET: _____

VIPER

SERVICE AND INSTALLATION MANUAL

TABLE OF CONTENTS

ITEM	PAGE NUMBER
FCC Warning	INSIDE FRONT COVER
Non-Leland Replacement Parts Notice	INSIDE FRONT COVER
Optimize Your Profits	INSIDE FRONT COVER
Machine Information	INSIDE FRONT COVER
Care and Feeding	2
Warranty Information	3
Viper Kit Installation Procedure	4
Action System PCB Conversion Diagram	6
To: The Tech	7
Troubleshooting Flow Chart	8
Troubleshootist's Section	
1. A Note About Power	9
a. DC Power	9
b. AC Power	9
2. Our Service Department	9
3. General Shooting	
a. Garbage	10
b. No Sound	10
c. No Control Or Function Switches	10
4. Monitor Shooting	
a. No Picture	10
b. Bad or No Sync	10
5. Buffers	10
About Mechanical Coin Counters	11
Bookkeeping and Diagnostics	
1. Main Menu	12
2. Bookkeeping	13
3. Diagnostics Menu	14
a. Buttons and Controls Test	15
b. Processor Memory Test	16
c. Video Alignment Test	17
d. Video Memory Test	18
e. Audio Subsystems Test	18
f. Background Screens	19
4. Game Set-Up	19
5. Hall of Fame	20
6. Game Duration Statistics	20
Diagrams and Schematics	
1. AC DC Power Connections	21
2. Action Cabinet Wiring Diagram	INSIDE REAR COVER
3. Action Cabinet / With Seat	22
4. Control Panel and Power Supply Assemblies	23
5. Vertical Mounting and Motion Assembly	24
6. Horizontal Mounting and Motion Assembly	25
7. Switching Power Supply	26
8. Rom Expansion Board Diagrams	27
9. Multi-Function Board Diagrams	29
10. Main Logic Board Diagrams	42
11. Monitor Schematic	CENTERSPREAD

THE CARE AND FEEDING OF A VIPER CONGRATULATIONS

With the purchase of a new VIPER game or mod you've become a member of TEAM LELAND. This membership enables you to enter a world of dependable products, quick and efficient customer service, and worry-free operation, seldom experienced in this world of "throw away" and "planned obsolescence".

A little cleaning and a few checks after each collection will keep your new game a steady earner for a long time to come.

FIRST: THE SET-UP

(If you have a mod for Danger Zone, go to the Kit Installation Section)

After unboxing the game and before plugging it in, check the cabinet for dings, scratches, or gouges and notify both the delivery agent and your distributor of anything you find that does not meet with your approval.

Unlock the cashbox and check the game for the following items:

1. Power Cord
2. Back Door Keys
3. Action Seat Mounting Screws

Got it? Good.

Check inside the back of the game for loose ICs on the board, loose connectors, or anything else that just doesn't seem right.

NEXT: THE POWER

All set? Well then plug that puppy in (grounded outlet only please!), turn it on (the interlock switch is inside the back door), and check for smoke. When the picture comes up, go to the bookkeeping and diagnostics section of this manual and go through every function. Check for proper settings, clean and adjust the monitor (VERY IMPORTANT!), and adjust the sound.

FINALLY: THE PLAY

Now PLAY THE GAME!!!!

Play it a few times. When you are sure that it works and is set to your satisfaction, it's time to make some bucks.

EACH COLLECTION: THE UPKEEP

Check the Bookkeeping and Game Duration Statistics to see how well your Game Set-Up options are working. Do some tinkering if you don't like what you see.

Make sure the game is clean and working properly. (HINT: Put a couple of coins through each coin mech to check for proper operation and play a game.)

GOOD LUCK - GIVE US A CALL - WE'D LIKE TO HEAR WHAT YOU HAVE TO SAY!!

THE LELAND CORPORATION WARRANTY

The Leland Corporation warrants that whenever the video display (monitor) and/or the power supply and/or the printed circuit boards and/or all parts contained therein are furnished with its product, that such part or parts will be free from defects in materials and workmanship for a period of sixty (60) days from date of shipment. The Leland Corporation's warranty of above parts is subject to the normal use and service of its product. No other products or parts thereof are warranted. If the products described in this manual fail to conform to this warranty, the Leland Corporation's sole liability shall be, as mutually agreed, to replace or repair such products which are returned to The Leland Corp. during stated warranty period, provided:

- a. The Leland Corp. is notified in writing upon discovery by buyer that said products are defective.
- b. The defective product or part is returned *pre-paid* to The Leland Corp. plant with a Leland Corp. *Returned Merchandise Authorization (RMA)* number clearly visible on the outside of the package.
- c. An Operator Service Card is on file at The Leland Corp. plant or is included in the package for all returned printed circuit boards.
- d. The Leland Corporations' examination of returned products determines to our satisfaction that the alleged defects existed and were not caused by accident, misuse, neglect, alteration, improper repair, installation, or testing.

The Leland Corp. is not responsible for bent pins on ICs not installed by our employees. In no event shall The Leland Corp. be liable for loss of profits, loss of use, incidental or consequential damages.

EXCEPT FOR THIS WARRANTY, THE LELAND CORP. DISCLAIMS ALL OTHER WARRANTIES, EXPRESSED OR IMPLIED, INCLUDING THE IMPLIED WARRANTIES OF MERCHANTABILITY AND FITNESS FOR A PARTICULAR PURPOSE, AND ALL OTHER OBLIGATIONS OR LIABILITIES ON THE LELAND CORPORATION'S BEHALF, AND IT NEITHER ASSUMES NOR AUTHORIZES ANY OTHER PERSON TO ASSUME FOR THE LELAND CORP. ANY OTHER LIABILITIES IN CONNECTION WITH THE SALE OF PRODUCTS MANUFACTURED BY THE LELAND CORP.

VIPER KIT INSTALLATION PROCEDURE

Calm Yourself. This could be one of the easiest conversions you've ever done. Just take this thing one step at a time.

FIRST: Disassembly.

Remove the following items from your old Danger Zone cabinet.

1. Printed Circuit Assembly
2. Complete Coin Door Assembly
3. 1 & 2 Player Buttons
(NOTE: Loosen but *DO NOT REMOVE* the two Joystick Assemblies.)
4. All Danger Zone Graphics (A little Lacquer Thinner will save a lot of elbow grease.)

SECOND: The Board. (See Action Cabinet PCB Conversion Diagram)

Grab the old Printed Circuit Assembly and the new Viper electronic parts and set them on a clean and preferably static-free work area (desk, work bench, etc.).

1. Remove the old Danger Zone top board.
2. Using a small slot screwdriver or an IC remover, carefully remove the following IC's from the Main PCB:

U1

U3 through U9

U67 through U70

U85

U89 through U95

U120

3. Insert the following new IC's into their respective locations in the Main PCB:

U3

U67 through U70

U85 (20 pin IC stenciled 0217)

U89 through U95

U120 (8 pin IC stenciled 271)

4. Insert the audio jumper socket (28 pin socket with wires soldered in positions 5 & 6) into socket at position U87 on the Main PCB.

5. Insert ribbon connectors into positions U1 & U99 on the Main PCB.

NOTE: In all of the above insertion operations, **DOUBLE CHECK** each device for proper orientation and pin placement!

6. Using the supplied hardware, mount the new Multi-Function PCB and ROM Ext. PCB in the positions shown.

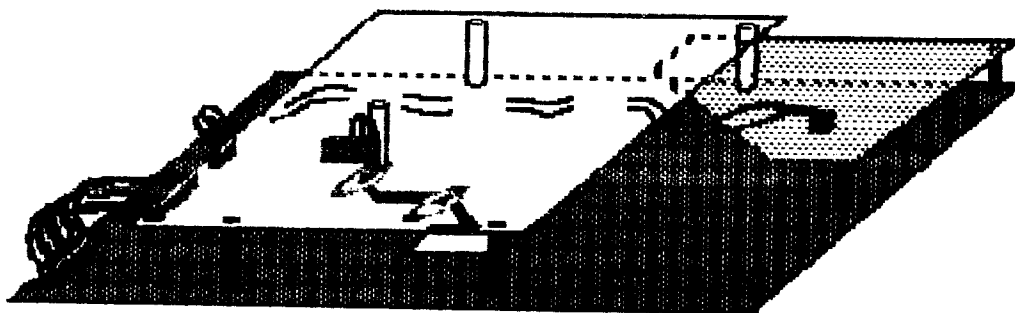

VIPER PCB MOUNTING DIAGRAM

7. Insert Z890 (removed from U1 on the Main PCB) into the socket at position U1 on the ROM Ext. PCB.
8. Attach audio jumper from Main PCB to the designated connector on the Multi-Function PCB.
9. Attach power jumper from the Multi-Function PCB to the ROM Ext. PCB.
10. Connect Main PCB power jumper and both ribbon connectors.

THIRD: The Cabinet. (See Action Cabinet / With Seat Illustration)

After removing the old graphics, install the new Viper graphics and remount the Coin Door Assy. Install the "Dst Tray" and mount the Action System Seat.

HINT: When applying the control panel graphics do not remove the joysticks. Simply pre-cut the joystick holes in the new graphic and cut a line from these holes to the nearest edge of the graphic. Then peel the backing from the top portion of the graphic, align the joystick holes and adhere the graphic. Now peel and stick the rest of the graphic.

STOP HERE -- GO OVER EVERYTHING YOU'VE DONE THUS FAR.

All OK? Fine, you're almost done.

Vacuum all the dust and stuff out of the cabinet.

Clean the monitor.

Install the new PCB set.

Tighten up the control panel.

Plug 'er in and power-up.

GOOD PICTURE?

If not, adjust it now and as long as you are going to be in diagnostics to adjust the picture, check out the other functions. Do the controls work? Are the Bookkeeping and Game Set-Up sections to your liking?

Last but not least - PLAY THE GAME!

We at The Leland Corp. would like to thank you for your support and would like to hear any questions or comments that you might have. Our goal is to produce the very best amusement products in the world and we invite your input.

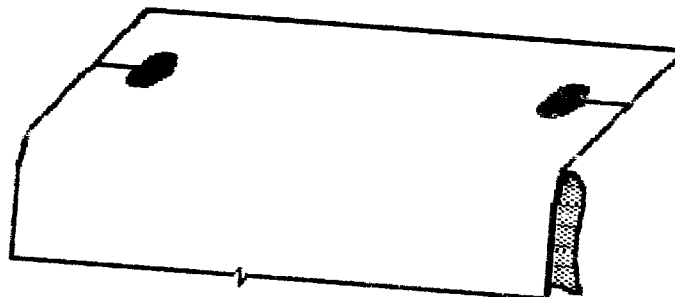

LELAND CORP. ACTION SYSTEM PCB CONVERSION DIAGRAM

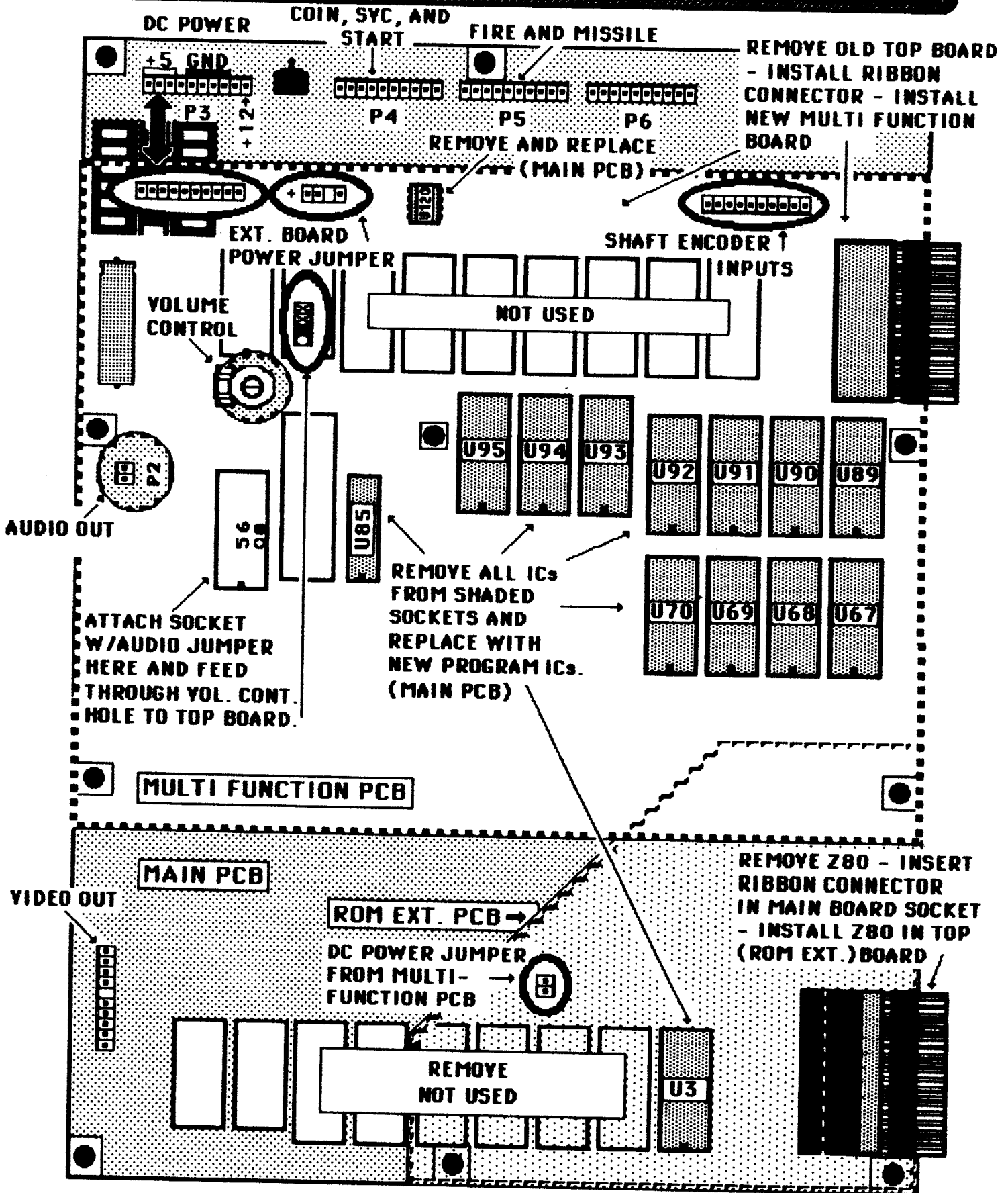

TO: THE TECH

FROM: THE GUY THAT WROTE THIS MANUAL

First of all, that little card that fell out when you opened this manual is your operator service card and we would appreciate it if you would take a couple of minutes to fill it out and send it to us with your comments. It is also a good idea to record the serial number information in the space provided at the front of this manual for future reference.

Next, this manual is not written for the "bench" technician except for the fact that we do include board layouts and schematic diagrams. As you are well aware, most of the problems incurred in the field are *not* board related. If you have double checked all the wiring, the power supply, the monitor, and where possible, "swapped" boards and have narrowed a problem down to the board, give us a call and our crack customer service department will get you going.

Because of solid state electronic circuitry, this game should require very little maintenance and only occasional adjustments. The majority of the problems encountered by field service technicians are of a type easily remedied, provided said technicians have at least a working knowledge of coin-operated amusement devices, the proper tools, and last but not least, a good attitude and a neat appearance.

FIRST: Approach the proprietor or attendant with a friendly greeting - "Good morning! And how are you on this fine and cheery morning?"

SECOND: List your credentials and purpose - "I'm _____ from _____ and I understand that one of our/your amusement machines is not functioning properly."

THIRD: Find out as much as possible about the problem before you approach the game - "I know that you are a busy man (or young lady) but if you would please explain exactly what the machine is doing or not doing that prompted your concern, I would be very grateful."

REMEMBER, YOU ARE A PROFESSIONAL!

Now that you've made a favorable impression and obtained a few facts, we can get down to brass tacks. (Which reminds me, be sure to check for foreign objects on the board.)

When examining an ailing machine, you may want to use the following flow chart as a foundation on which to build your troubleshooting approach.

TROUBLESHOOTING FLOW CHART

DON'T TOUCH THAT SWITCH !!!

Before you reach for the power switch take a good look at the game. Open it up and check for loose wires, bad connections, or burned spots. Look for spilled drinks and signs of vandalism. These quick checks will save you a lot of time.

After you've eliminated the obvious, start digging.

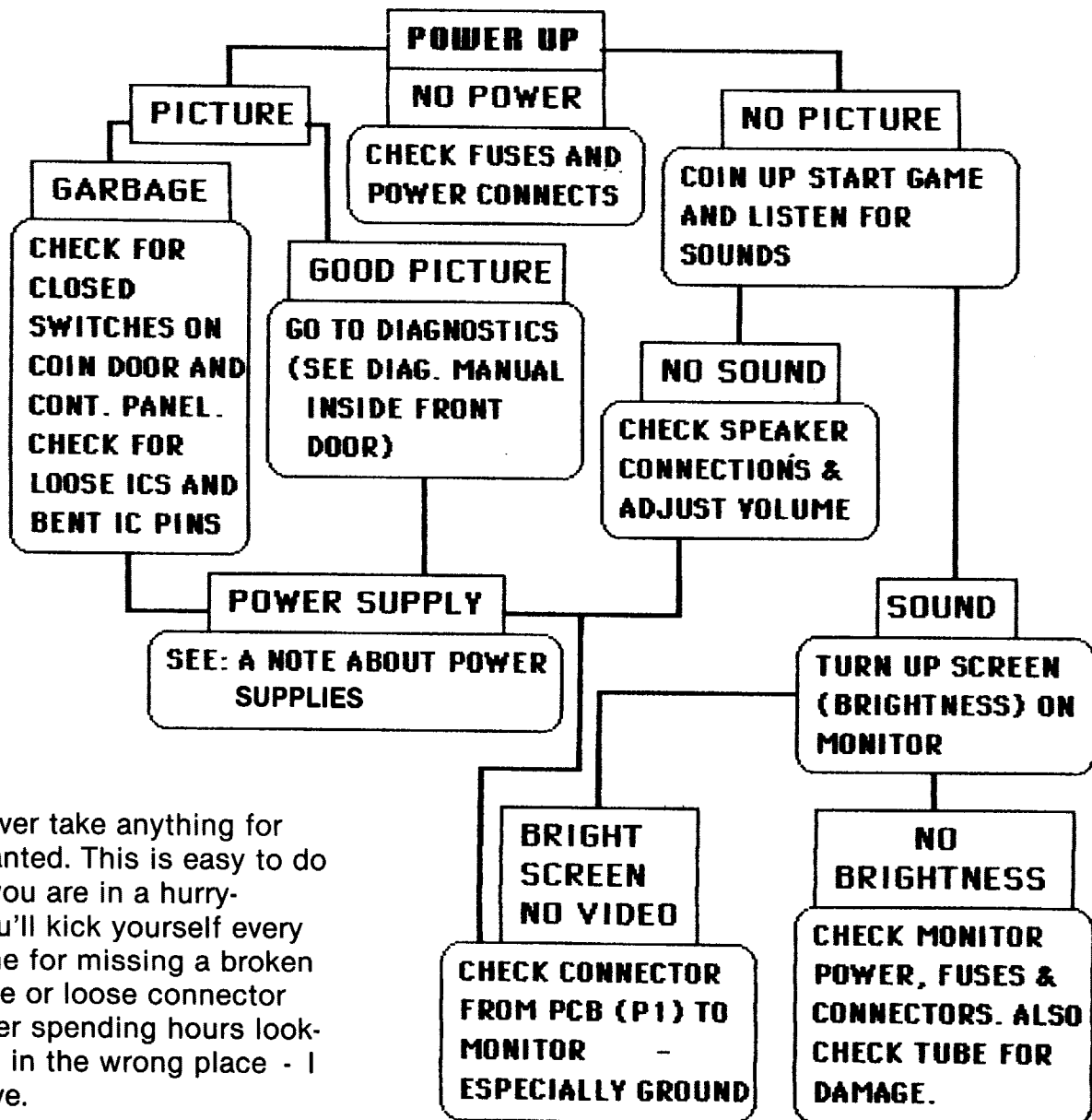

Never take anything for granted. This is easy to do if you are in a hurry- You'll kick yourself every time for missing a broken wire or loose connector after spending hours looking in the wrong place - I have.

THE TROUBLESHOOTIST'S SECTION

A NOTE ABOUT POWER

DC POWER

The computer board in this machine operates most efficiently when the power supply is providing a steady +5.1VDC (± 0.05 VDC). When checking DC power always put your leads across the power inputs on the main board and be sure that the +5 volt supply is between +5.05VDC and +5.15VDC. Also be sure that there is less than .005 volts AC riding on the +5 volt line. If you do find AC on the DC line, suspect the filter capacitor or the rectifier on the power supply. Low voltage or AC on the DC lines is the main cause of the following problems:

- *"Garbage" on the screen.
- *Computer "Freeze".
- *Coin or Coin Meter malfunction.
- *A variety of seemingly unrelated problems.

AC POWER

Connect this game only to a grounded three-wire outlet which provides between 108 and 132 volts AC. If you have only a two-wire outlet we recommend that you hire a licensed electrician to install a grounded outlet. The possibility exists that players may receive an electrical shock if this system is not properly grounded.

OUR SERVICE DEPARTMENT

For parts, service, and technical information first contact your authorized Leland Corporation distributor. For additional technical aid feel free to contact The Leland Corp. Customer Service Department at (619) 562-7000 Monday through Friday from 8:00 AM to 5:00 PM Pacific Standard Time. To provide you with the quickest possible response to your questions, please have the following information ready when you call:

1. Your game name and serial number.
2. Any reference materials and a list of observations.

GENERAL SHOOTING

GARBAGE

Check:

Power supply voltages.
Closed switches on control panel or coin door.
Loose connections or loose chips on board.

NO SOUND

Check:

Loose connections.
Low + 12 volt supply.
Bad speaker or pot.
(See BUFFERS)

NO CONTROL OR FUNCTION SWITCHES (Including coin switches)

Check:

Loose connections or broken wires. (Be sure to check ground connections and wires.)
Closed switch.
Input Buffer. (Follow edge connector trace to the first chip on the board.) - (See BUFFERS)

MONITOR SHOOTING

NO PICTURE

Check:

Power connection.
Blown monitor fuse.
Video connection. (Check for continuity.)
Turn up screen control and check for brightness.
Broken tube or neck board.

BAD OR NO SYNC

Check:

Sync and ground connections.
Sync polarity.
If your monitor will not handle negative sync you may have to install the following inverter circuit.
(See BUFFERS)

BUFFERS

An I/O buffer is the component that connects the actual computer to the outside world and, as such, is the part most likely to fail. Check the following list when attempting to isolate possible problems. First and second choices are given. (M = Main Board, I/O = Multi Function Board.)

NOTE: ANY UNAUTHORIZED BOARD REPAIR OR ATTEMPTED REPAIR WILL VOID YOUR WARRANTY.

<u>PROBLEM AREA</u>	<u>COMPONENT</u>	<u>PCB LOCATION</u>
COLORS OR SYNC	1st 7405 (or 74S05) 2nd 74LS374	M - U24 M - U37
PLAYER CONTROLS NAD/OR COIN INPUTS (See sheet 4 of main pcb schematic.)	1st 150 ohm resistor pack 2nd 74LS257	M - RP3 through RP8 M - U117, U118, & U119
AUDIO (Bad channel- 0 through 5)	1st 7524 2nd 7533	IO -U35(CH5) THROUGH U40 (CHO) I/O - U31

ABOUT MECHANICAL COIN COUNTERS

We have *not* installed a mechanical coin counter on this game for two reasons:

1. The bookkeeping program on VIPER™ is very accurate and includes not only number of coins dropped and dollars earned but also the number of tests and coins in a given period. (See BOOKKEEPING in the DIAGNOSTICS MANUAL.)
2. These mechanical counters produce an inductive “kick” that *will* damage components on the circuit board. Checkerboard video is the most common. To see if this is in fact your problem — take a look at the “NMI not” signal on the master Z80 (pin 17). If a low output is observed, try replacing U114 (74LS08) and/or U119 (74LS157).

NOTE: *If you must install a coin counter, please use the following diagram. (Diodes may be IN4001 to IN4004).*

HOOK BOTH COIN SWITCHES TO EITHER P4 PIN 5 OR P4 PIN 8.

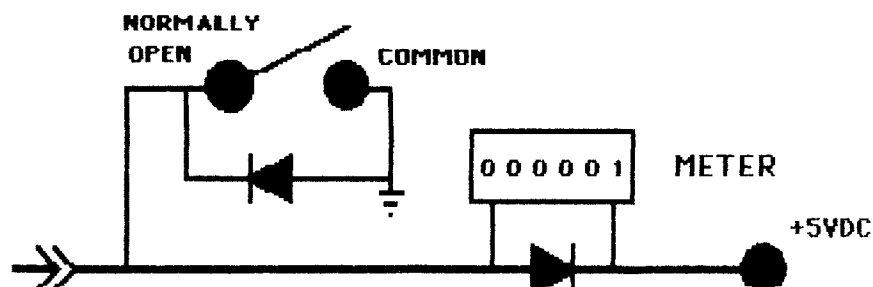

BOOKKEEPING AND DIAGNOSTICS

To enter the Bookkeeping and Diagnostics program:

- *Press and hold the 1 Player Start Button.
- *Press the Test Button (located inside the front door).
- *Release both buttons.

MAIN MENU

Upon entering the program a Main Menu will appear. Follow the instructions on this menu to select and enter the desired function. Notice that the program serial number is also displayed in the bottom left corner of this screen.

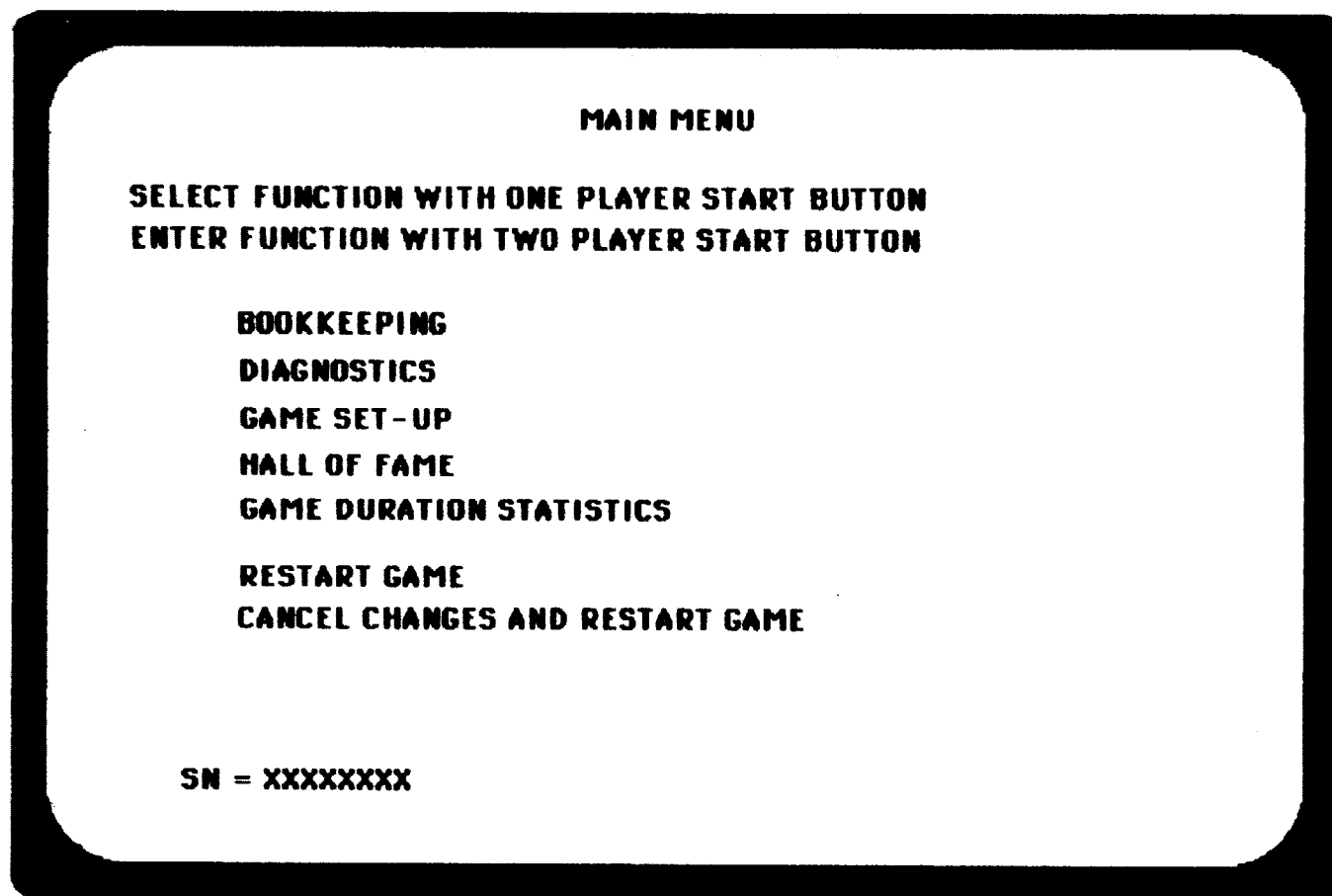

BOOKKEEPING

The Bookkeeping function is your game accountant. It records the lifetime earnings of your game and allows you, through the use of resettable "PERIOD" totals to keep track of weekly, monthly, or location earnings.

NOTE: The "SET COINS/TOKENS PER DOLLAR" category must be set to the location standard to maintain accurate accounting data. (i.e. If the arcade is giving 6 tokens per dollar, the COINS/TOKENS category should be set at "6 COINS PER DOLLAR COIN MECH 1" and 2.)

THIS FUNCTION *DOES NOT* AFFECT THE NUMBER OF COINS PER CREDIT! (See the "GAME SET-UP" section for this information.)

BOOKKEEPING			
SELECT FUNCTION WITH ONE PLAYER START BUTTON			
ENTER FUNCTION WITH TWO PLAYER START BUTTON			
	LIFETIME COINS	PERIOD COINS DOLLARS	
COINS DROPPED - MECH 1	0	0	\$0.00
COINS DROPPED - MECH 2	0	0	\$0.00
TOTAL COINS DROPPED	0	0	\$0.00
SERVICE BUTTON PRESSED	0		
TOTAL CREDITS GIVEN	0		

RESET COIN MECH 1 DOLLARS COLLECTED
RESET COIN MECH 2 DOLLARS COLLECTED

SET COINS/TOKENS PER DOLLAR:
4 COINS PER DOLLAR COIN MECH 1
4 COINS PER DOLLAR COIN MECH 2

RETURN TO MAIN MENU

*CIRCLED AREAS
MAY BE CHANGED*

DIAGNOSTICS MENU

Invoking the Diagnostics function will open a very complete and easy-to-use set of tests designed to take the grumbling and hair-pulling out of adjusting, troubleshooting, and servicing your machine.

You will notice that the diagnostics section has a sub-menu of its own, which is intended to help isolate problem areas.

DIAGNOSTICS

**SELECT FUNCTION WITH ONE PLAYER START BUTTON
ENTER FUNCTION WITH TWO PLAYER START BUTTON**

BUTTONS AND CONTROLS TEST

PROCESSOR MEMORY TEST

VIDEO ALIGNMENT TEST

VIDEO MEMORY TEST

AUDIO SUBSYSTEMS TEST

VIEW BACKGROUND SCREENS

RETURN TO MAIN MENU

BUTTONS AND CONTROLS TEST

This test provides a quick examination of the state of all buttons and controls as well as an easy range-setting format for the horizontal and vertical position sensors.

There are two types of position sensors.

In the first of these devices, horizontal and vertical indexes or flags rotate through optical sensors to locate the directional middle of the horizontal and vertical movement. Suspect improper positioning of these flags or failure of the associated driver board when the horizontal or vertical scrolling indicators are not centered on the test screen.

The second device, the encoder shaft, senses the amount of horizontal or vertical movement. These encoder shafts must be manually centered and the optimum readings are shown on the test screen. To set either encoder, loosen the mounting bracket enough to allow the small gear to move freely, adjust to the proper reading, and reposition the encoder assembly. Be sure to allow the small and large gears to interact smoothly with each other. DO NOT force them together too tightly.

PLEASE PRESS THE FOLLOWING BUTTONS

PLAYER ONE START	CLOSED	←	<i>SWITCHS SHOW</i>
PLAYER TWO START	OPEN		<i>"CLOSED" WHEN</i>
MECH ONE COIN SWITCH	OPEN		<i>PUSHED.</i>
MECH TWO COIN SWITCH	OPEN		
SERVICE SWITCH	OPEN		
FIRE BUTTON	OPEN		
MISSILE BUTTON	OPEN		

HORIZONTAL SCROLLING: 512 (± 5 AT REST)



VERTICAL SCROLLING: 512 (± 3 AT REST)



**PRESS FIRE AND MISSILE AT THE SAME TIME TO
CALIBRATE TURRET.
PRESS THE PLAYER TWO OR SERVICE BUTTON TWICE TO EXIT**

PROCESSOR MEMORY TEST

The Erasable Programmable Read Only Memory (EPROM) and Random Access Memory (RAM) chips are storage areas for the actual game guidelines and are accessed by the Microprocessor section. The percentage of field failures in these areas is very low but when problems do arise they can be a bear to track down. This next test samples the action of the processor section and notes any incongruities.

WARNING: Read your warranty before attempting any printed circuit board repairs.

PROCESSOR MEMORY TEST

MASTER ROM TESTED
MASTER ROM GOOD

EXAMPLE:
MASTER ROM TESTED BAD
CHIP UXX SUSPECT



MASTER RAM TESTED
MASTER RAM GOOD

COLOR RAM TESTED
COLOR RAM GOOD

SLAVE MEMORY TEST

SLAVE ROM GOOD
SLAVE RAM GOOD

PLAYER 2 START EXITS TESTING

VIDEO ALIGNMENT TEST

The picture on the screen is the most important and the most neglected part of the game. It is a proven fact that a dirty, misaligned, or unfocused screen will cause a player to walk away even if the game is his or her favorite piece.

A little elbow grease and a couple of minutes taken to go through these adjustment screens will make a big difference in the cashbox. Use all three screens to adjust your picture and then go the "Background Screens" section to make sure the game looks *rich*.

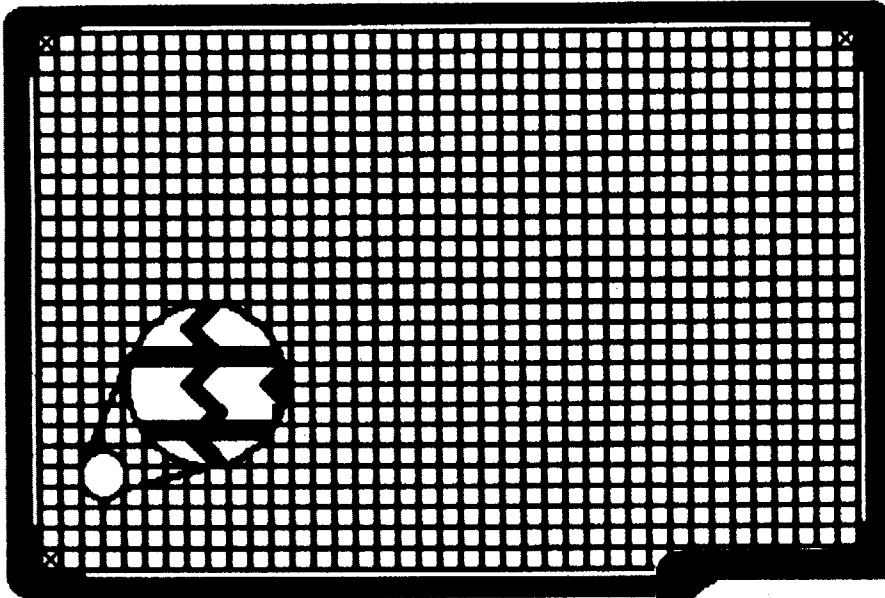

THE CROSS-HATCH SCREEN

Used to adjust focus, size, contrast, convergence, and alignment. Notice the x's in the corners. Wavy horizontal lines (see inset) denote bad contrast. The background should be black and the lines should be white.

RED AND GREEN SCREEN

Adjust screen control so that the green color bar shows faintly on the one level and then use the red cutoff control to adjust the red to the same intensity.

RED AND GREEN TEST

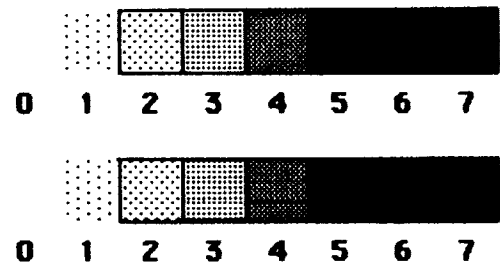

BLUE AND MISCELLANEOUS

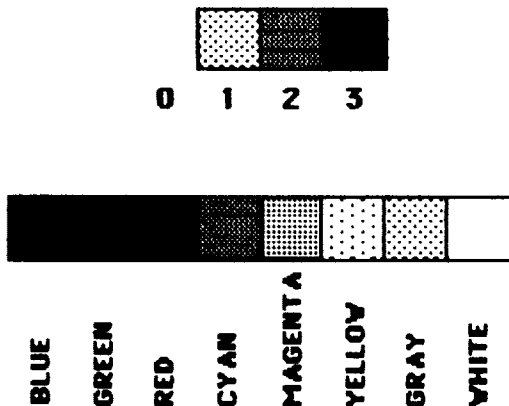

BLUE AND MISC. SCREEN

Use the blue cutoff control to make the gray color bar look gray. Adjust the red and green drive controls slightly if necessary to make the white color bar white.

VIDEO MEMORY TEST

A video memory test is an asset in any troubleshooter's game plan and "praise be" we've included one in our game. This test is invaluable in isolating those "lines on the screen" or "pieces of stuff in the picture" problems.

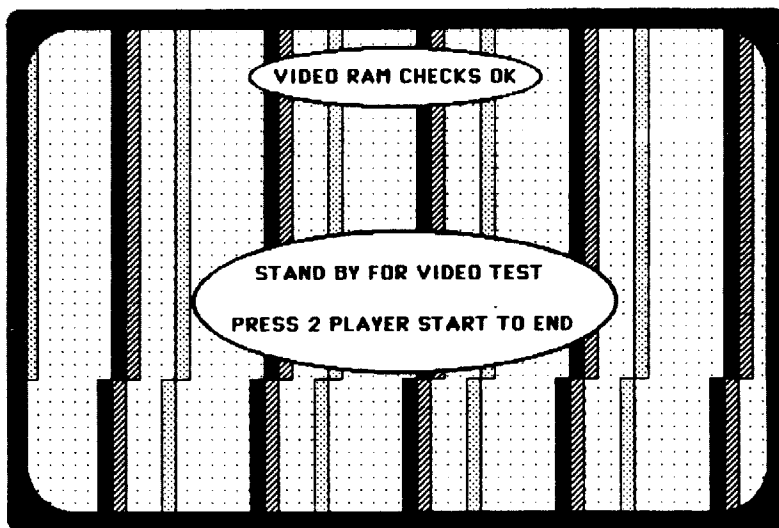

AUDIO SUBSYSTEMS TEST

The sounds are the second most important feature of any game and are essential to the "feel" of the game. The volume or level of sound is, for the most part, dictated by the owner or attendant of a location and is thus a "given", but the quality of the sound is a function of the program. This test will help in your quest to find those odd sounds or remedy the lack of certain sounds.

Some Sound Advice: Those annoying ATTRACT MODE SOUNDS are supposed to draw attention - let them!

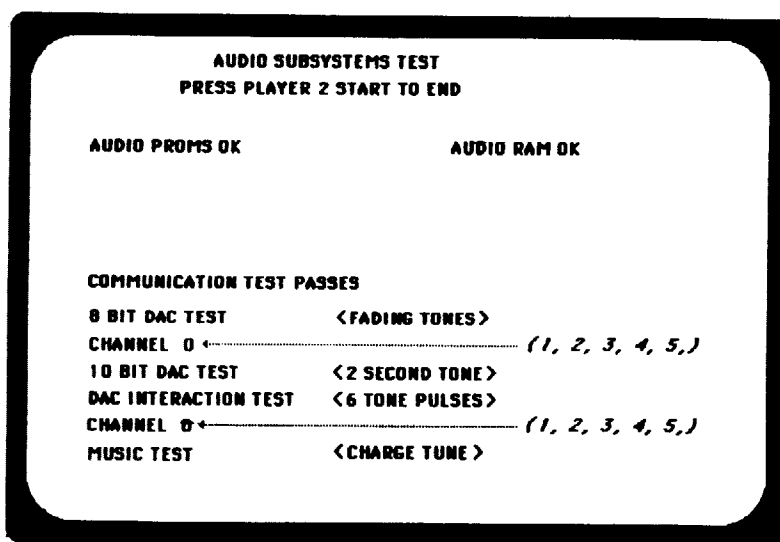

BACKGROUND SCREENS

The background screens are shown while the EPROMS, which contain the information for these screens, are displayed at the top of the screen. This test is not only helpful when looking for those "glitches" one sometimes comes across in the background of the picture, but may also be viewed as a visual test of the color and picture clarity after the Video Alignment Test has been completed.

And now, back to the Main Menu!

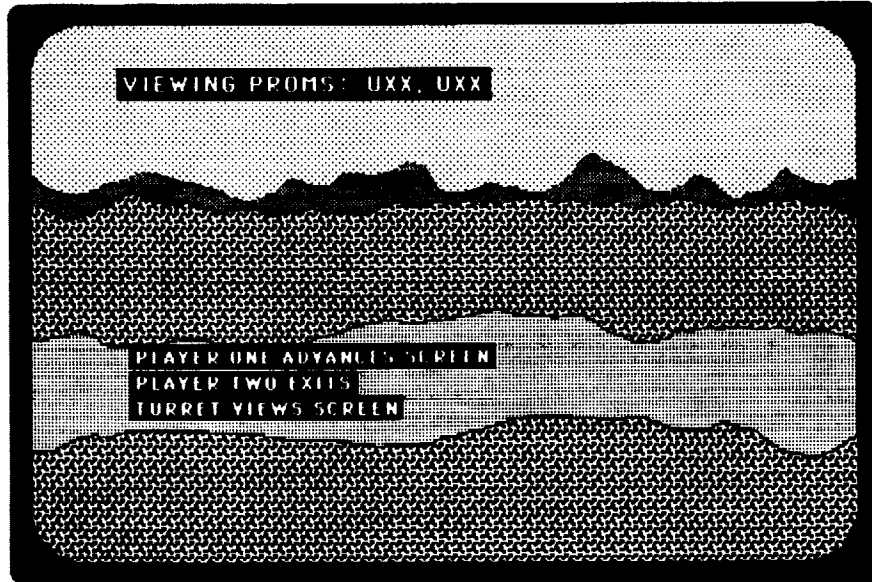

GAME SET-UP

The game set-up section is vital to the condition of your cashbox. When used in conjunction with the "Bookkeeping" and "Game Duration" areas of this diagnostics package, this function will keep your game in the thick of it for many collections. The coins-per-credit setting ranges from 1 coin - 1 credit to 20 coins - 20 credits and all denominations in between. We recommend that the attract mode and continue play features remain "ON". The difficulty levels may be set from 1 (easiest) to 8 (most difficult) and the number of lives may be from 1 to 5 per credit.

I'm sure that you will find that it pays to keep on top of the records and do a little tinkering to keep your game fine-tuned for profit.

GAME SET-UP

SELECT FUNCTION WITH ONE PLAYER START BUTTON
ENTER FUNCTION WITH TWO PLAYER START BUTTON

COIN MECH 1

1 COIN FOR
1 CREDIT
NO EXTRA PLAY

*CIRCLED AREAS
MAY BE CHANGED*

COIN MECH 2

1 COIN FOR
1 CREDIT
NO EXTRA PLAY

ATTRACT MODE SOUND ----- YES
DIFFICULTY LEVEL ----- 3
NUMBER OF LIVES TO START WITH ----- 3
CONTINUE PLAY FEATURE ----- YES

RETURN TO MAIN MENU

HALL OF FAME

Every once in a while it's a good idea to let someone else get to the top. This feature also helps when running tournaments.

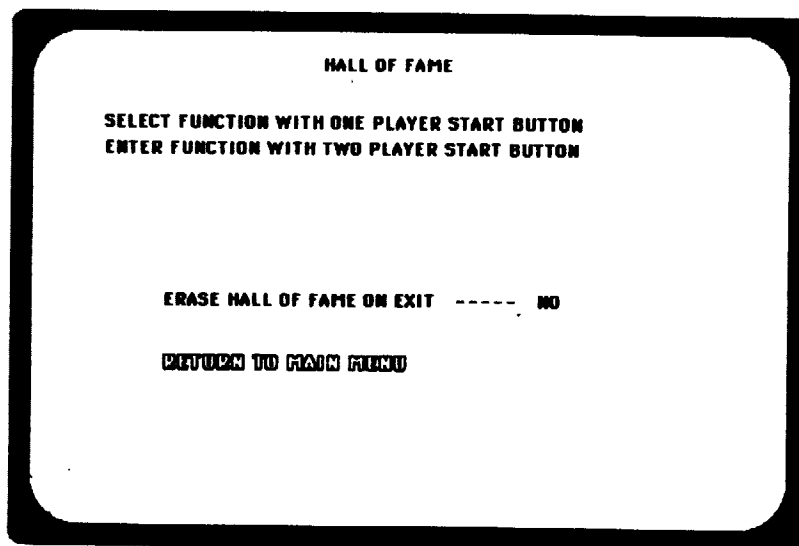

GAME DURATION STATISTICS

This section is your REPORT CARD. It lets you know how well you've done at setting your game for maximum earning power.

Since this is a "lives-per-credit" game, your game keeps track of the average length of games played for you. Use this tally along with your "Game Set-Up" function and try to keep each game between 2 and 2-1/2 minutes.

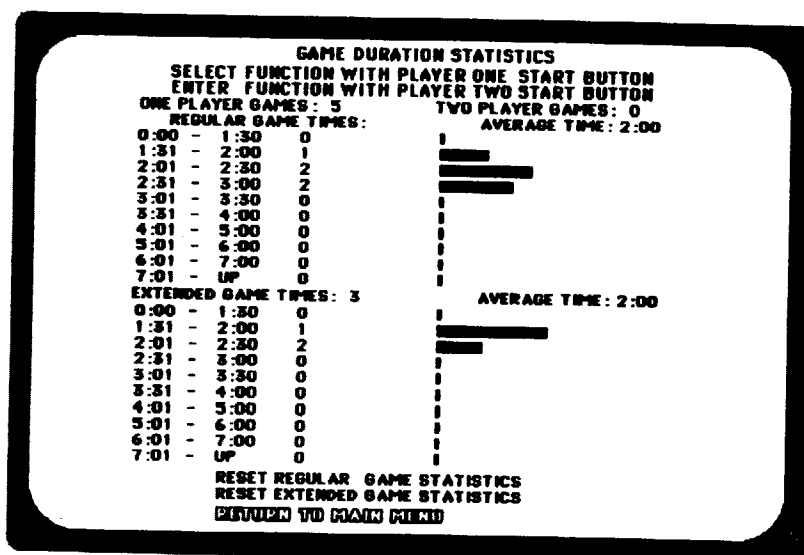

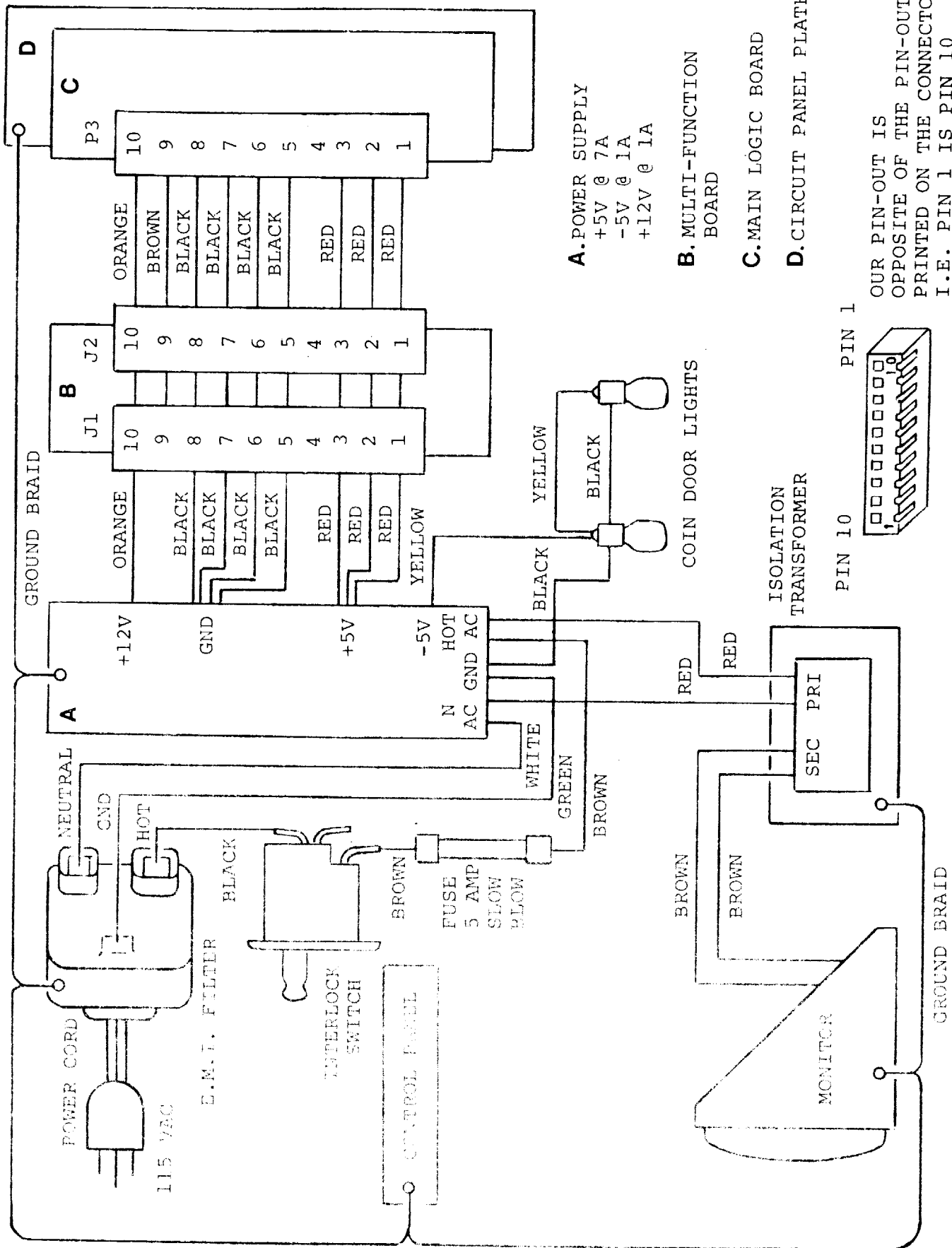

AC/DC POWER CONNECTION

**LELAND CORP. ACTION
CABINET / WITH SEAT**

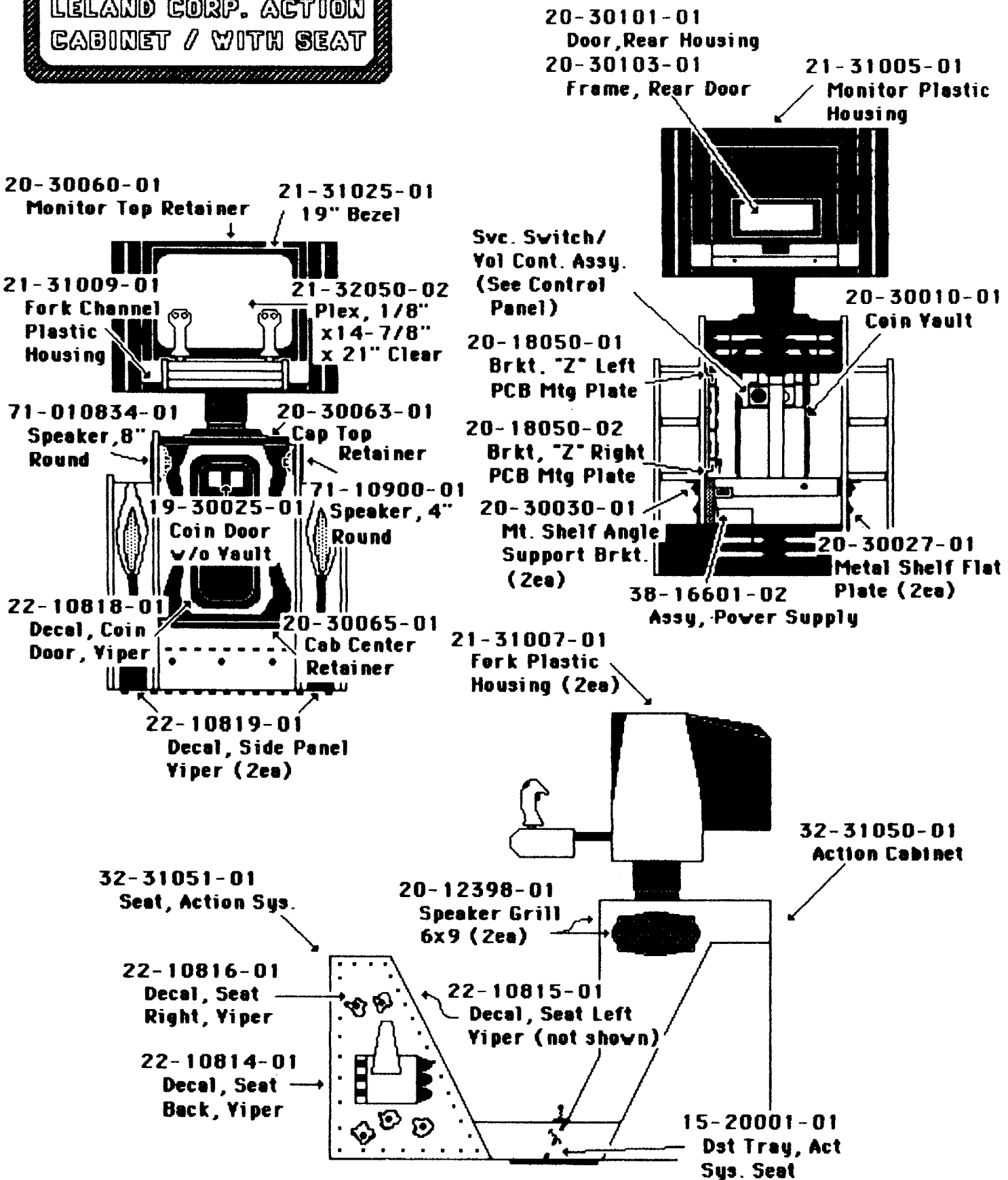

LELAND CORP. ACTION CABINET CONTROL PANEL AND POWER SUPPLY ASSEMBLIES

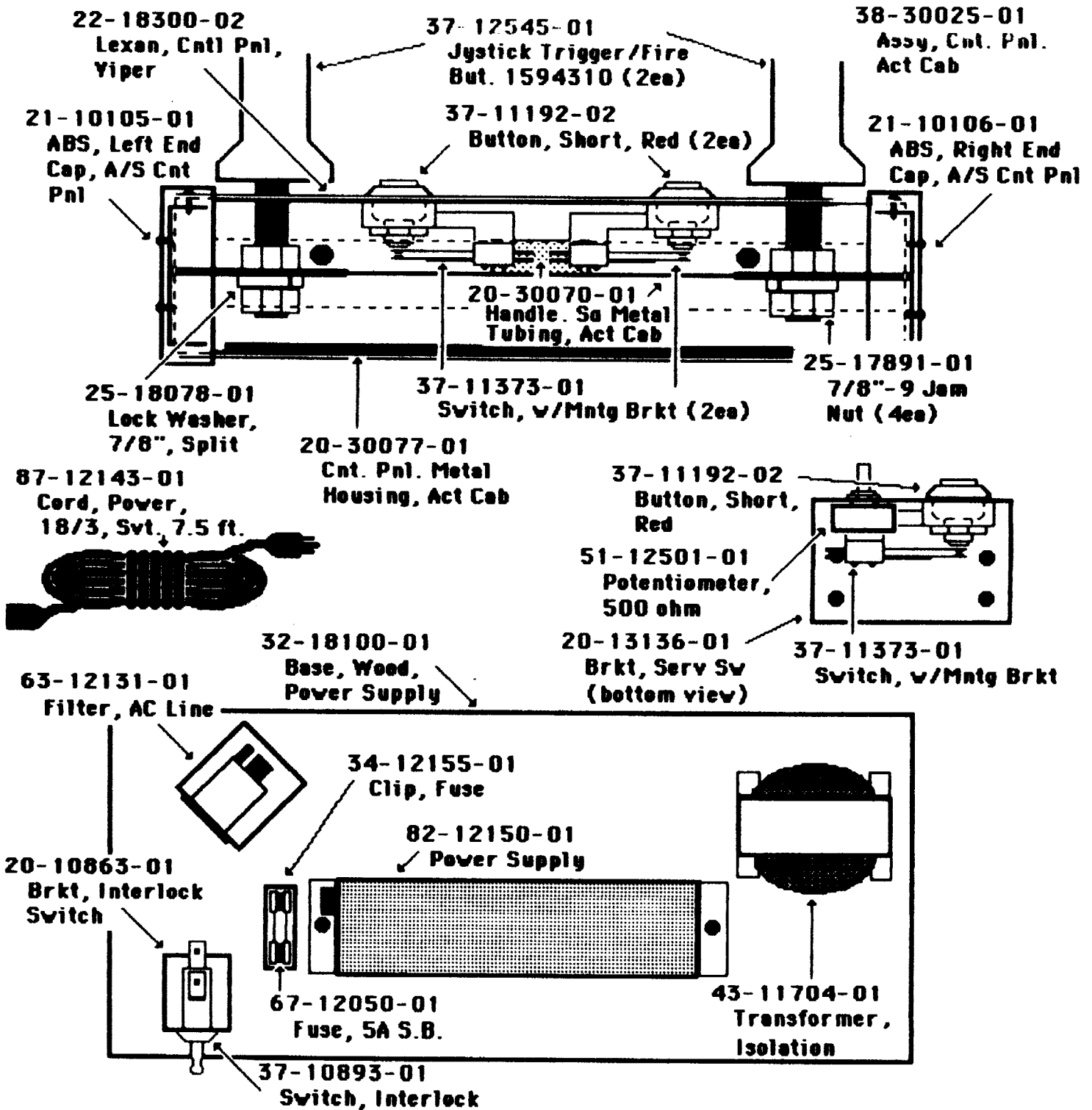

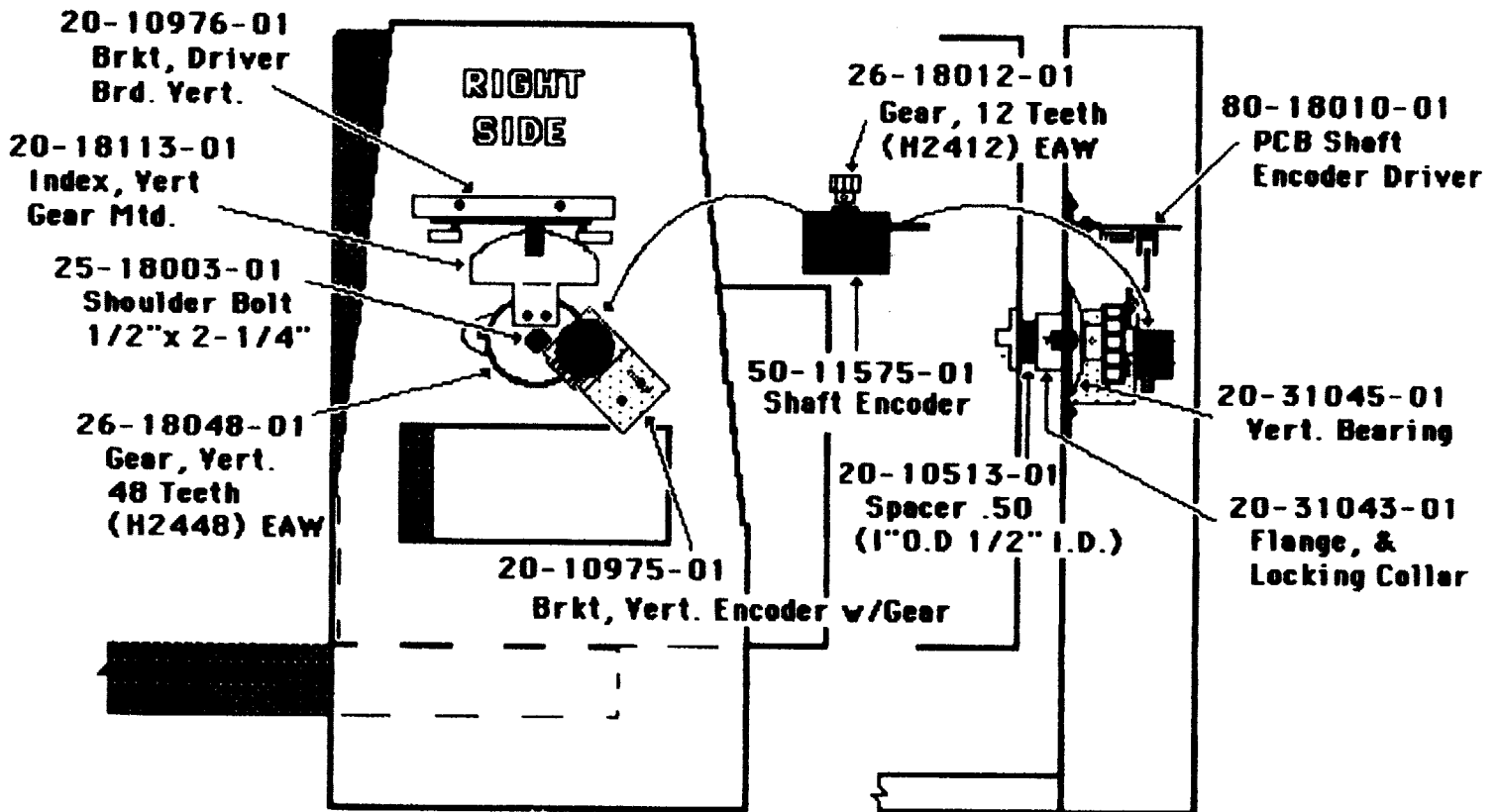
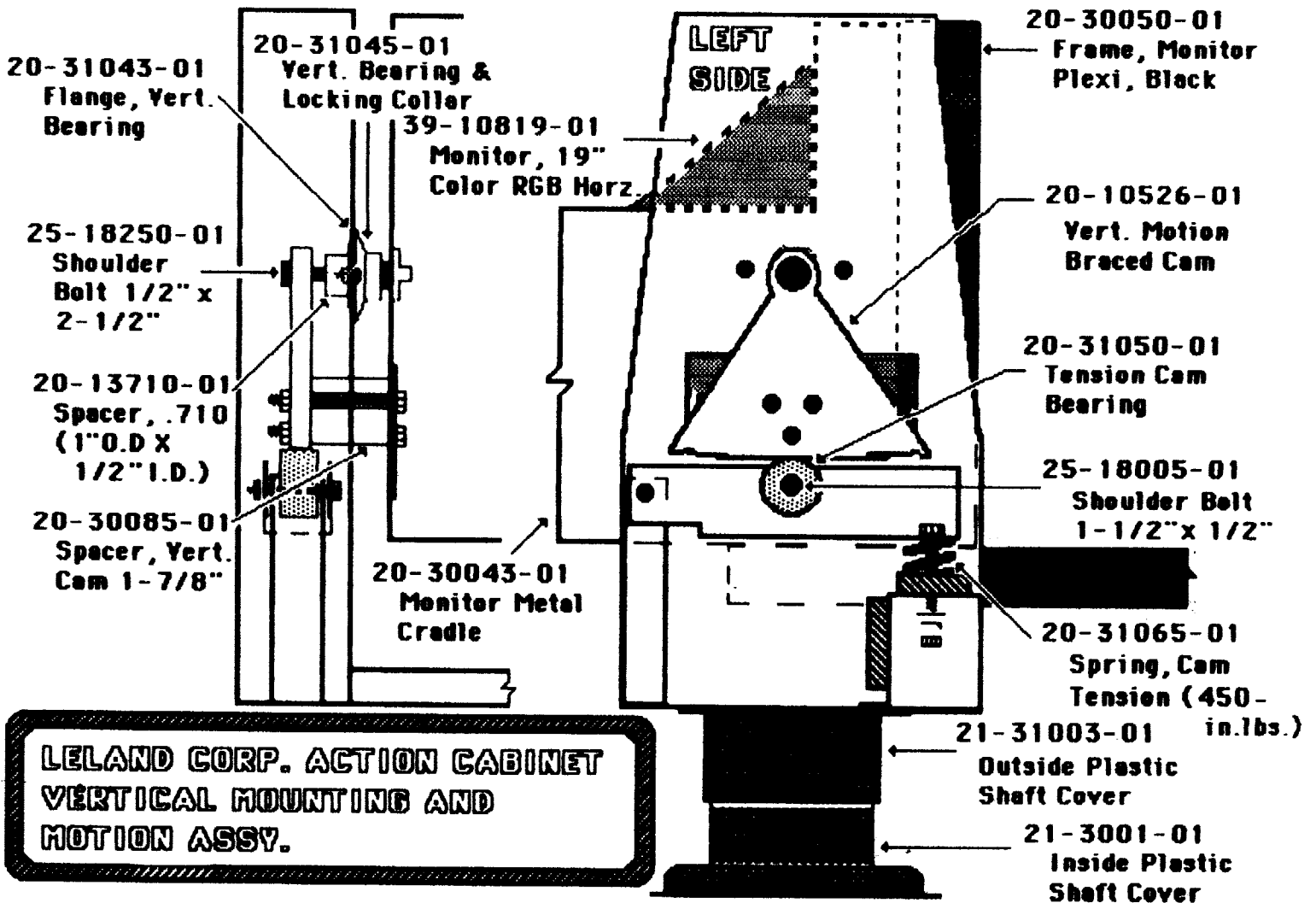

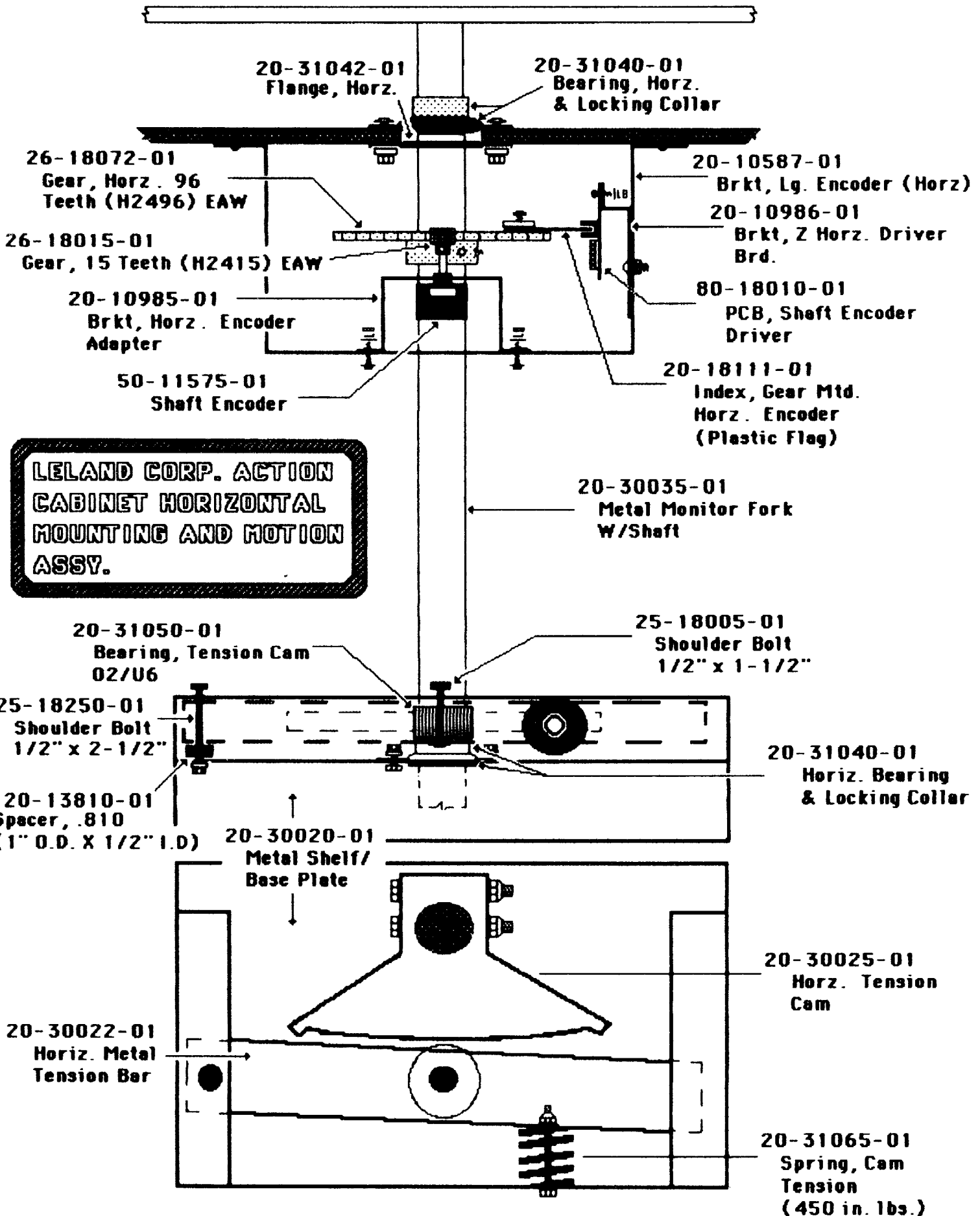

SWITCHING POWER SUPPLY

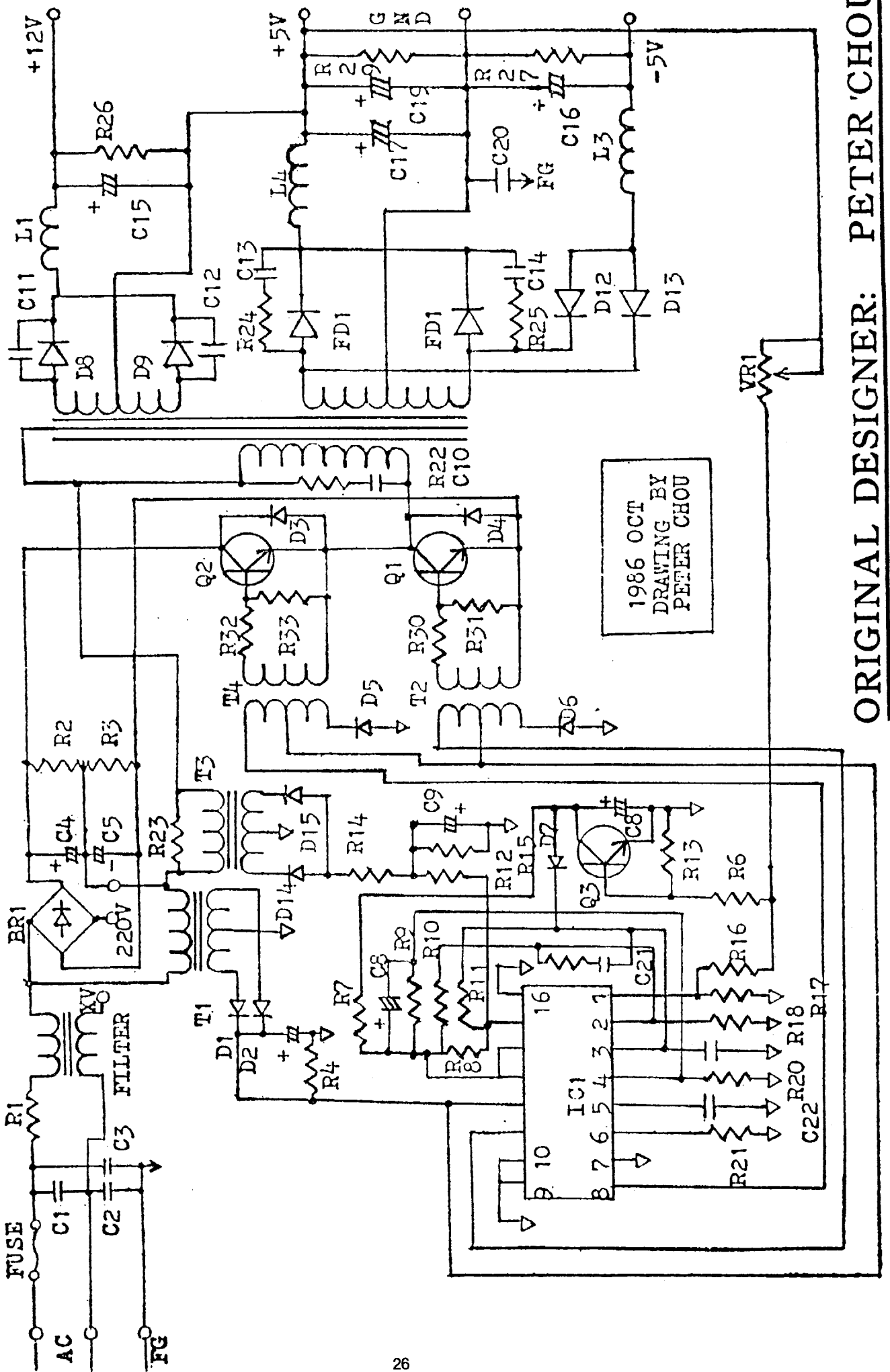

ORIGINAL DESIGNER: PETER CHOU

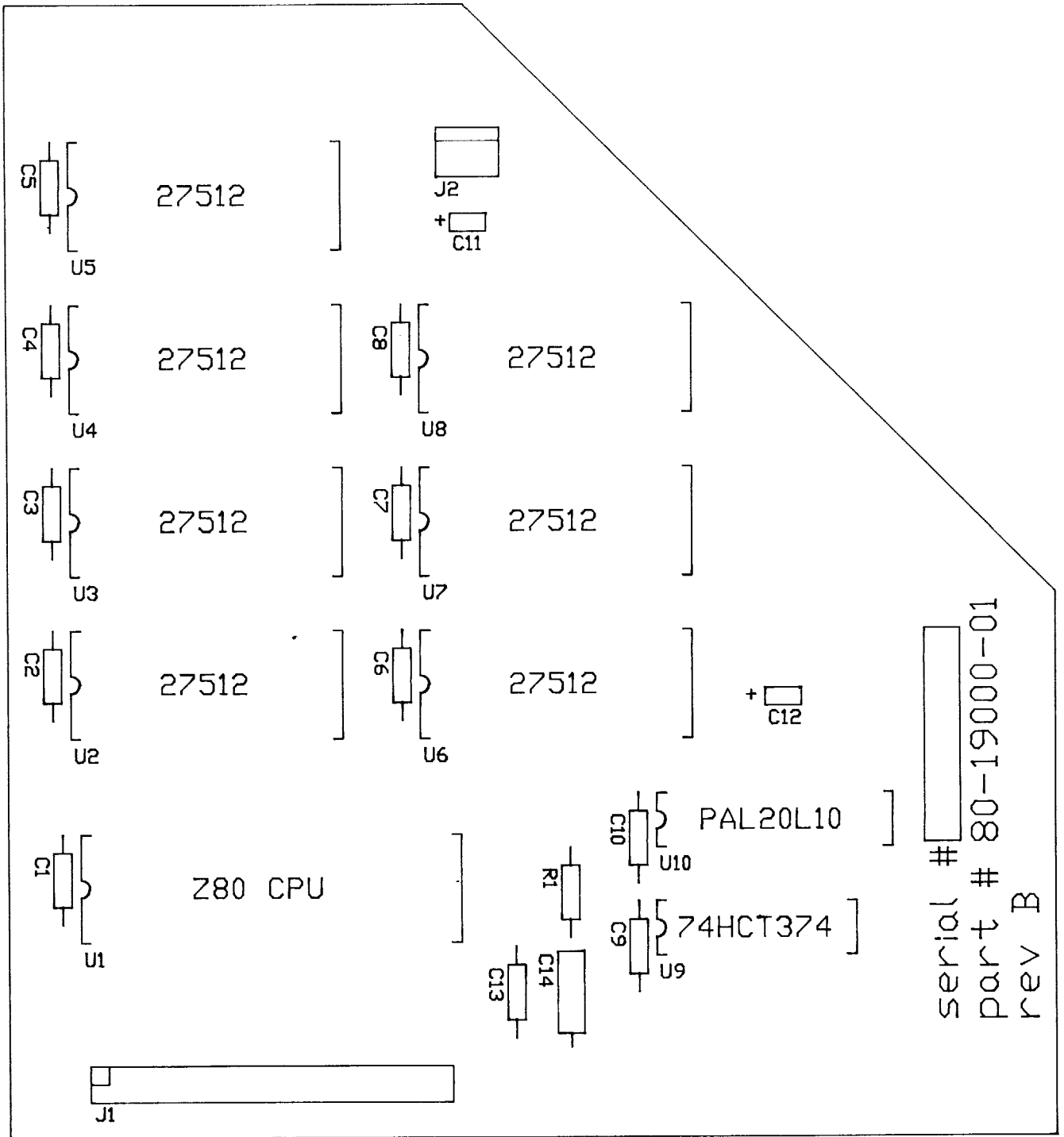

serial # []
 part # 80-19000-01
 rev B

ROM EXPANSION BOARD

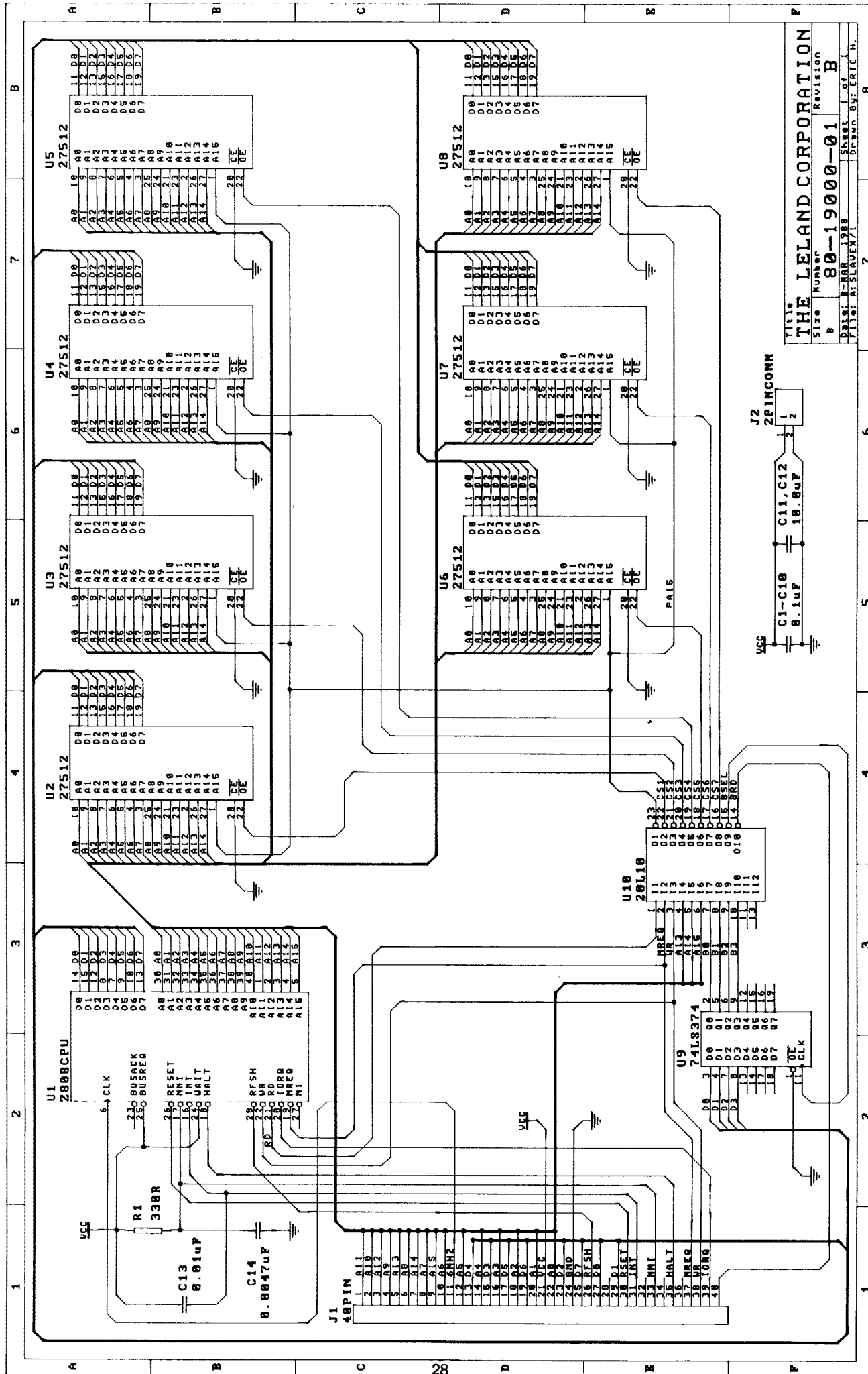

TITLE THE LELAND CORPORATION
 SIZE NUMBER 80-19000-01
 REVISION B
 DATE: 8-MAR-1988
 FILE: A.SR.VEN/71
 DRAWN BY: ERIC H.

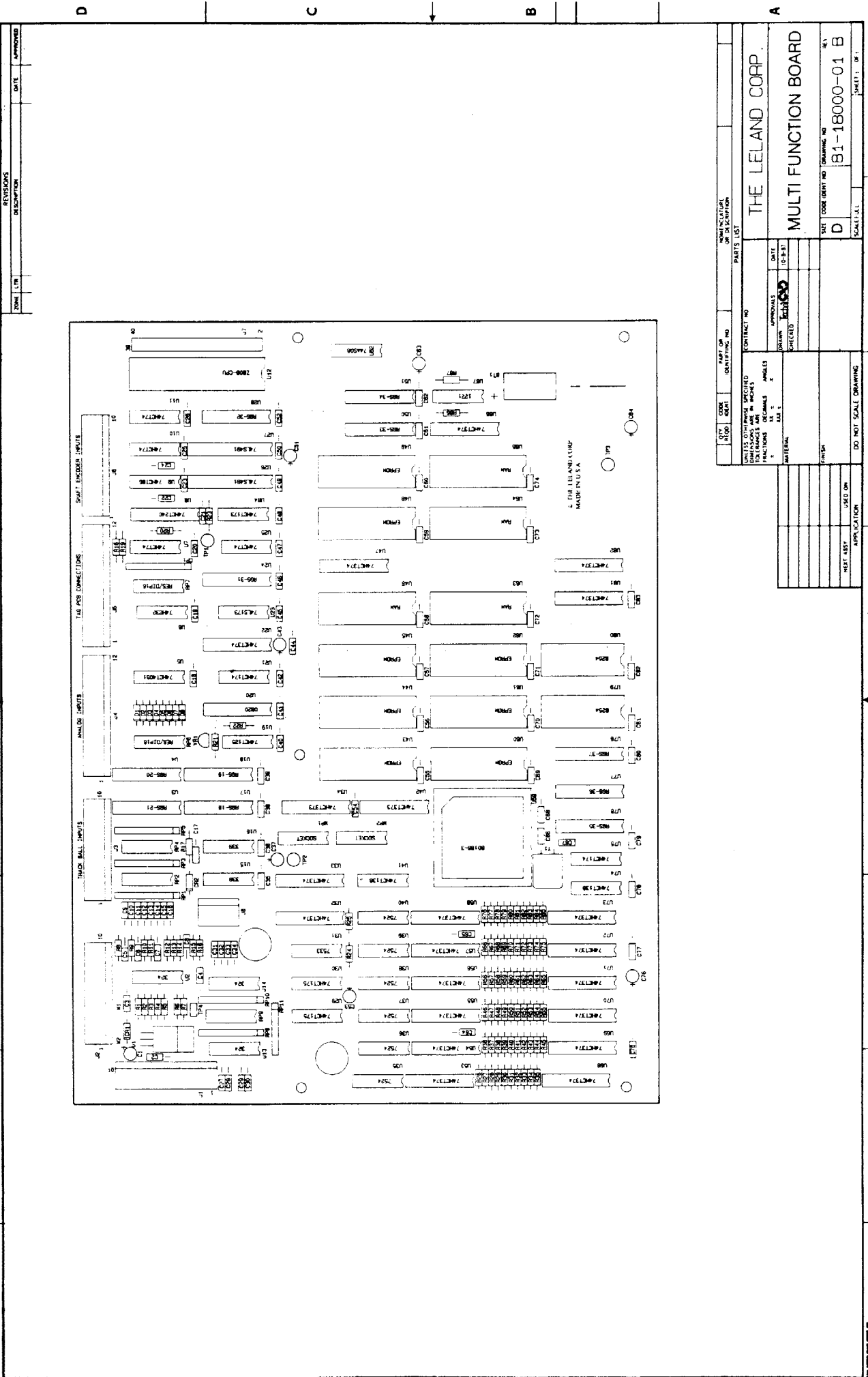

THE LELAND CORP.	
MULTI FUNCTION BOARD	
CONTRACT NO.	
DRAWN BY	
CHECKED BY	
DATE	
APPROVED BY	
DATE	
SIZE CODE	D
FORM NO.	81-18000-01 B
REVISIONS	
NO. REV.	
DATE	
DESCRIPTION	

QTY.	CODE	PART OR IDENTIFYING NO.
1		
2		
3		
4		
5		
6		
7		
8		

DO NOT SCALE DRAWING	
NEET ASSY	USED ON
APPLICATION	

8 7 6 5 4 3 2 1

REVISIONS

NO.	DATE	APPROVED
1		
2		
3		
4		
5		
6		
7		
8		

K7000 COLOR MONITOR SCHEMATIC DIAGRAM

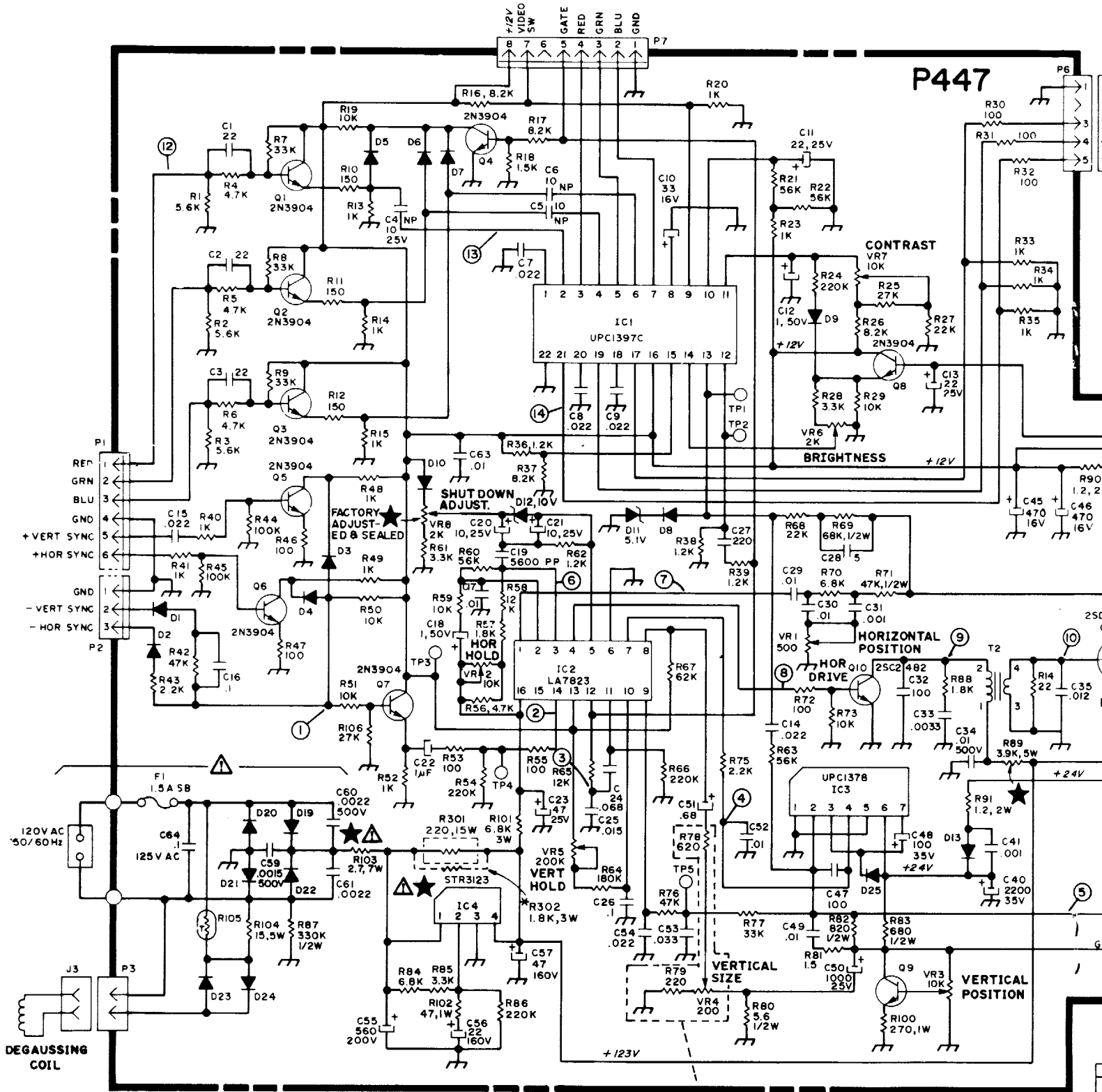

*R302 IS PRESENT ONLY ON 19K7600 AND 19K7900 SERIES MONITORS.

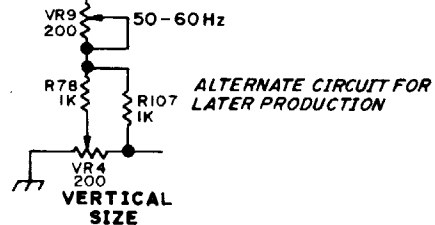

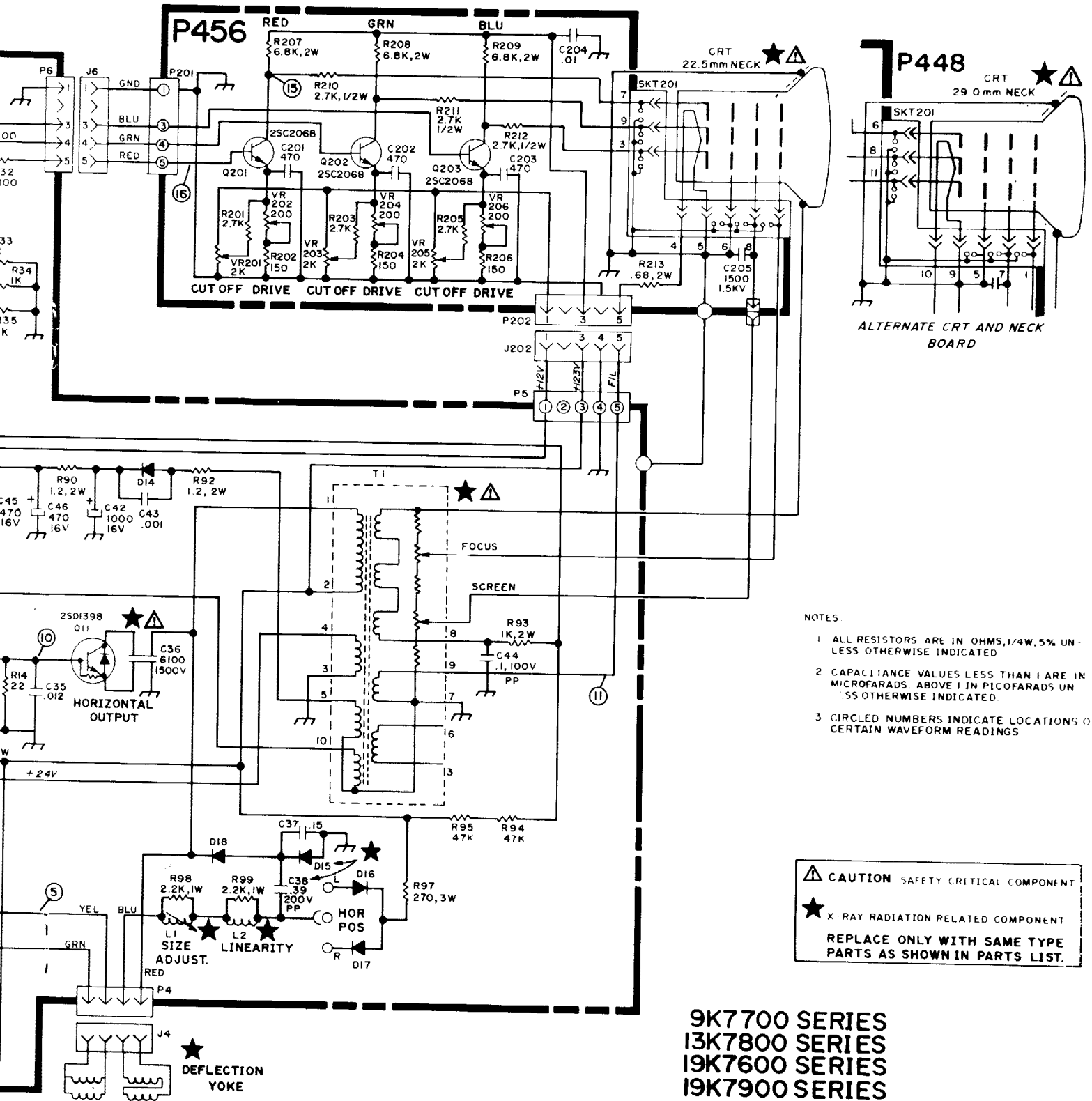

- NOTES:
- 1 ALL RESISTORS ARE IN OHMS, 1/4W, 5% UNLESS OTHERWISE INDICATED
 - 2 CAPACITANCE VALUES LESS THAN 1 ARE IN MICROFARADS, ABOVE 1 IN PICOFARADS UNLESS OTHERWISE INDICATED
 - 3 CIRCLED NUMBERS INDICATE LOCATIONS OF CERTAIN WAVEFORM READINGS

CAUTION SAFETY CRITICAL COMPONENT

X-RAY RADIATION RELATED COMPONENT

REPLACE ONLY WITH SAME TYPE PARTS AS SHOWN IN PARTS LIST.

9K7700 SERIES
13K7800 SERIES
19K7600 SERIES
19K7900 SERIES

NOTE:
 REFER TO OTHER SCHEMATIC DIAGRAMS FOR CERTAIN UNIQUE MODELS.

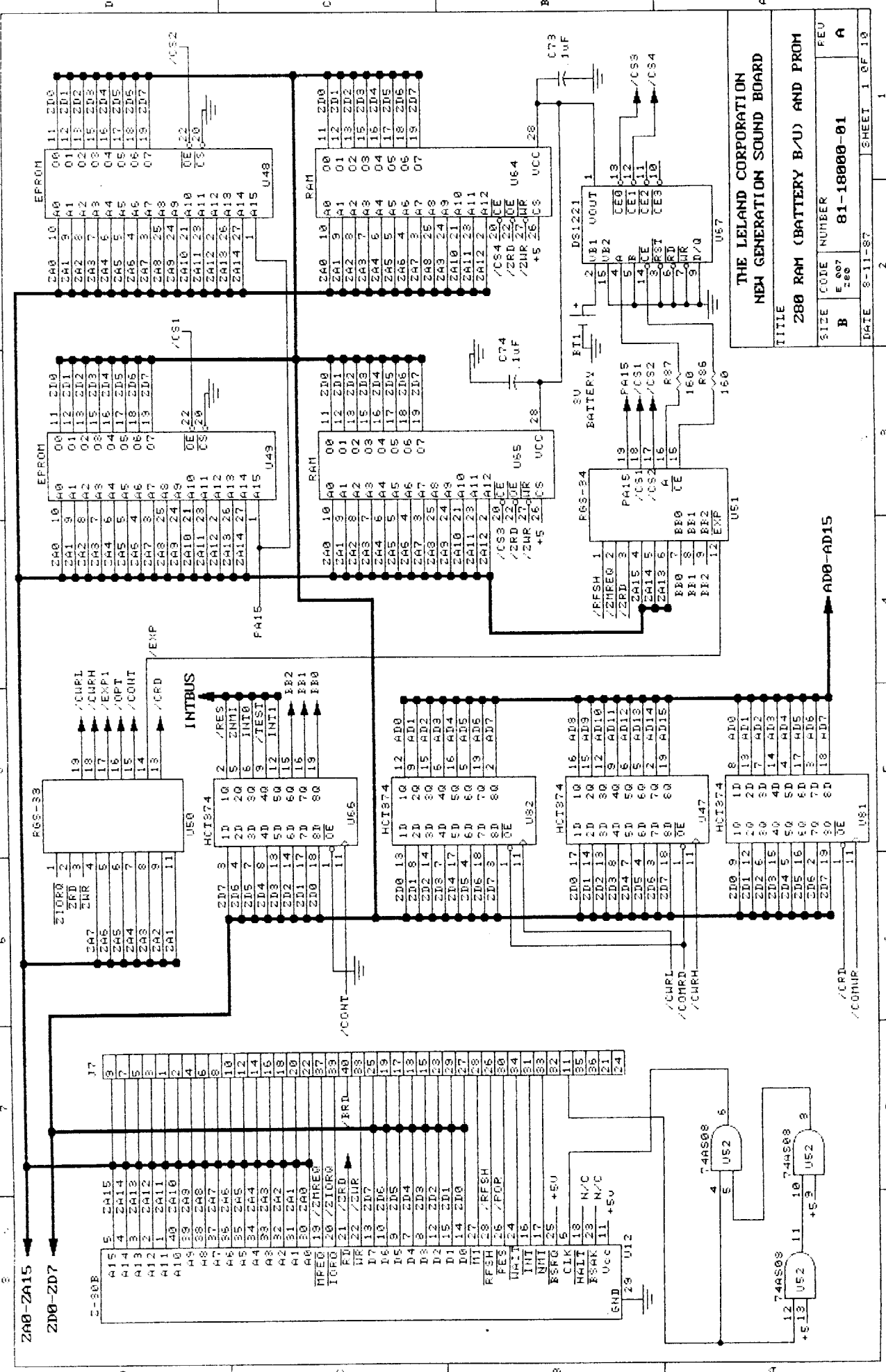

THE LELAND CORPORATION
 NDA GENERATION SOUND BOARD

TITLE
 280 RAM (BATTERY B/U) AND PROM

SIZE CODE NUMBER
 E 007
 81-18000-01

FEU
 A

DATE 8-11-87 SHEET 1 OF 10

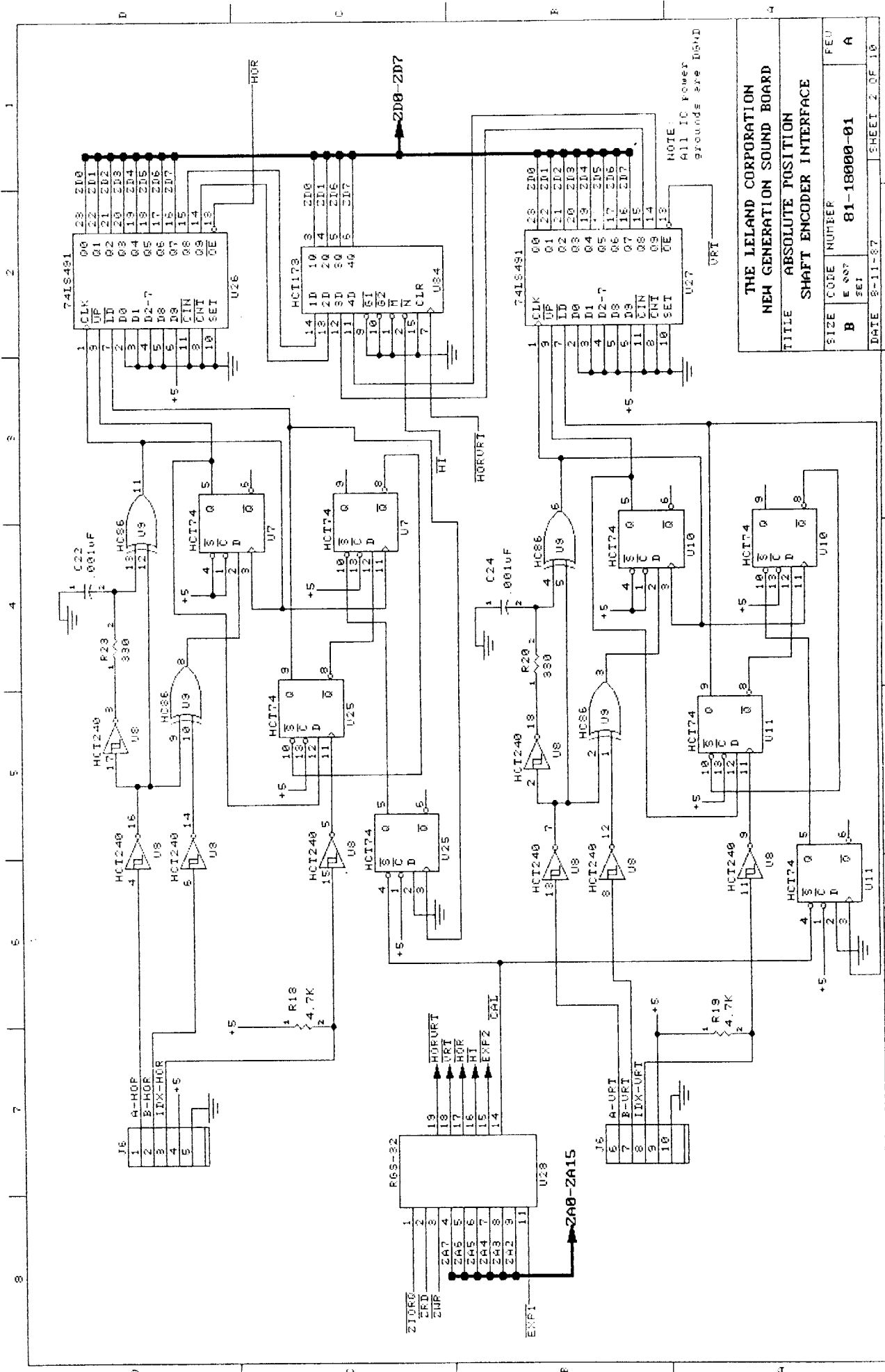

THE LELAND CORPORATION	
NEW GENERATION SOUND BOARD	
TITLE SHAFT ENCODER INTERFACE	
SIZE	FEU
B	A
CODE NUMBER	
81-18000-01	
DATE	SHEET
8-11-87	2 OF 10

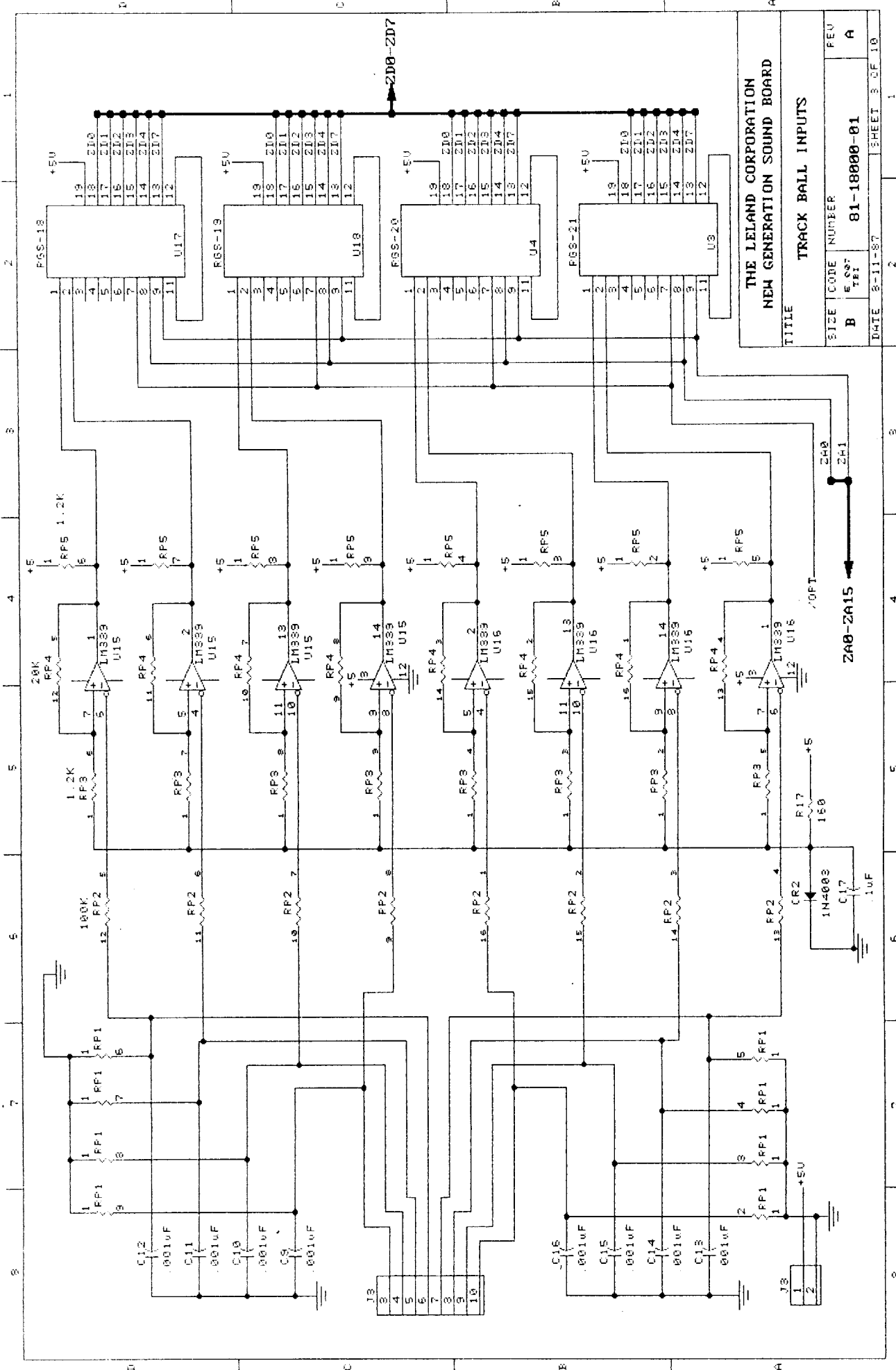

THE LELAND CORPORATION
 NEW GENERATION SOUND BOARD

TITLE		
SIZE	CODE	NUMBER
B	ESS?	81-18800-01
TRACK BALL INPUTS		REV A

DATE 8-11-87 SHEET 3 OF 10

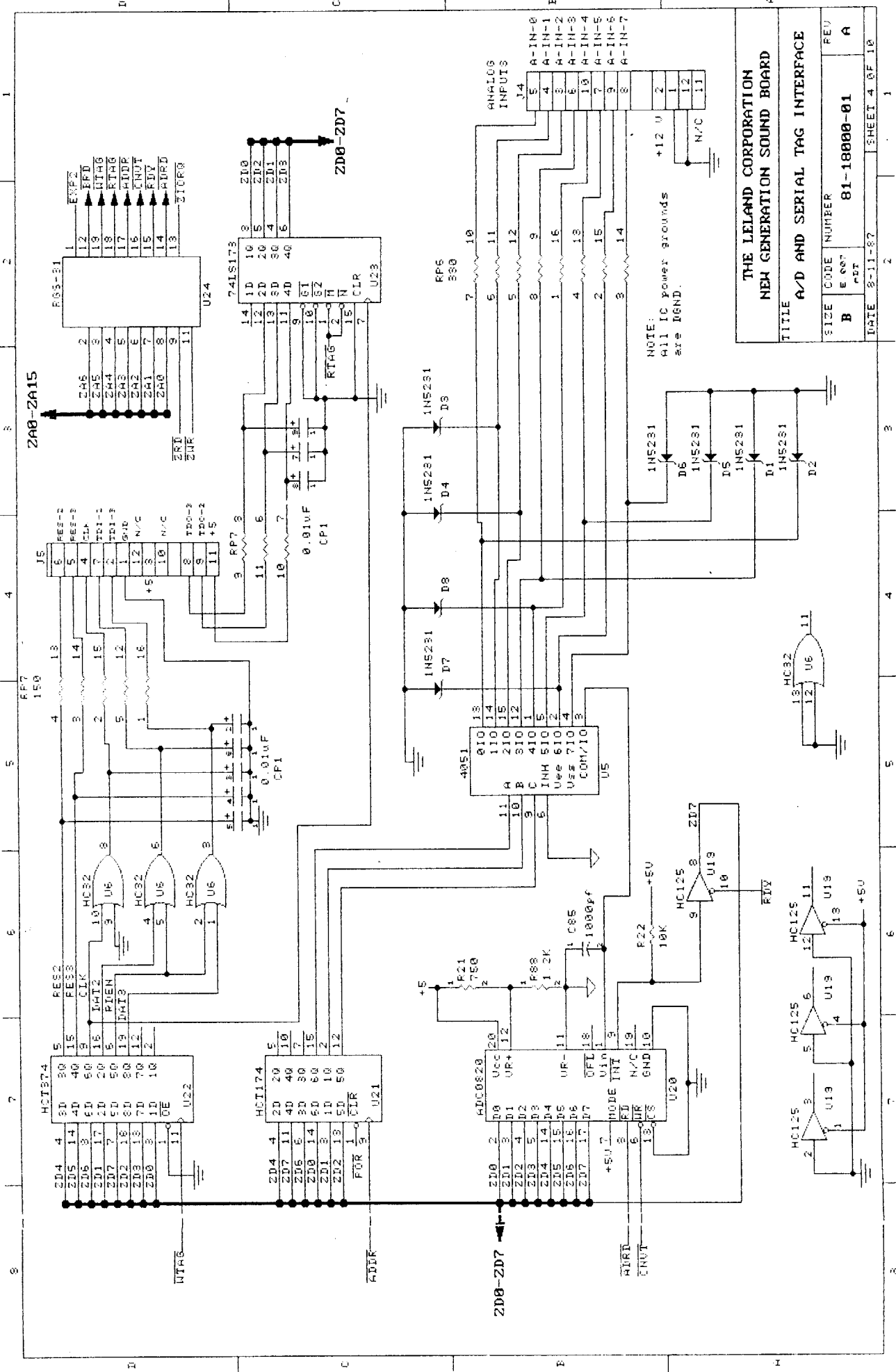

THE LELAND CORPORATION
NEW GENERATION SOUND BOARD

TITLE
A/D AND SERIAL TAG INTERFACE

SIZE	CODE	NUMBER	REV
B		81-18800-01	A

DATE 8-11-82 SHEET 4 OF 10

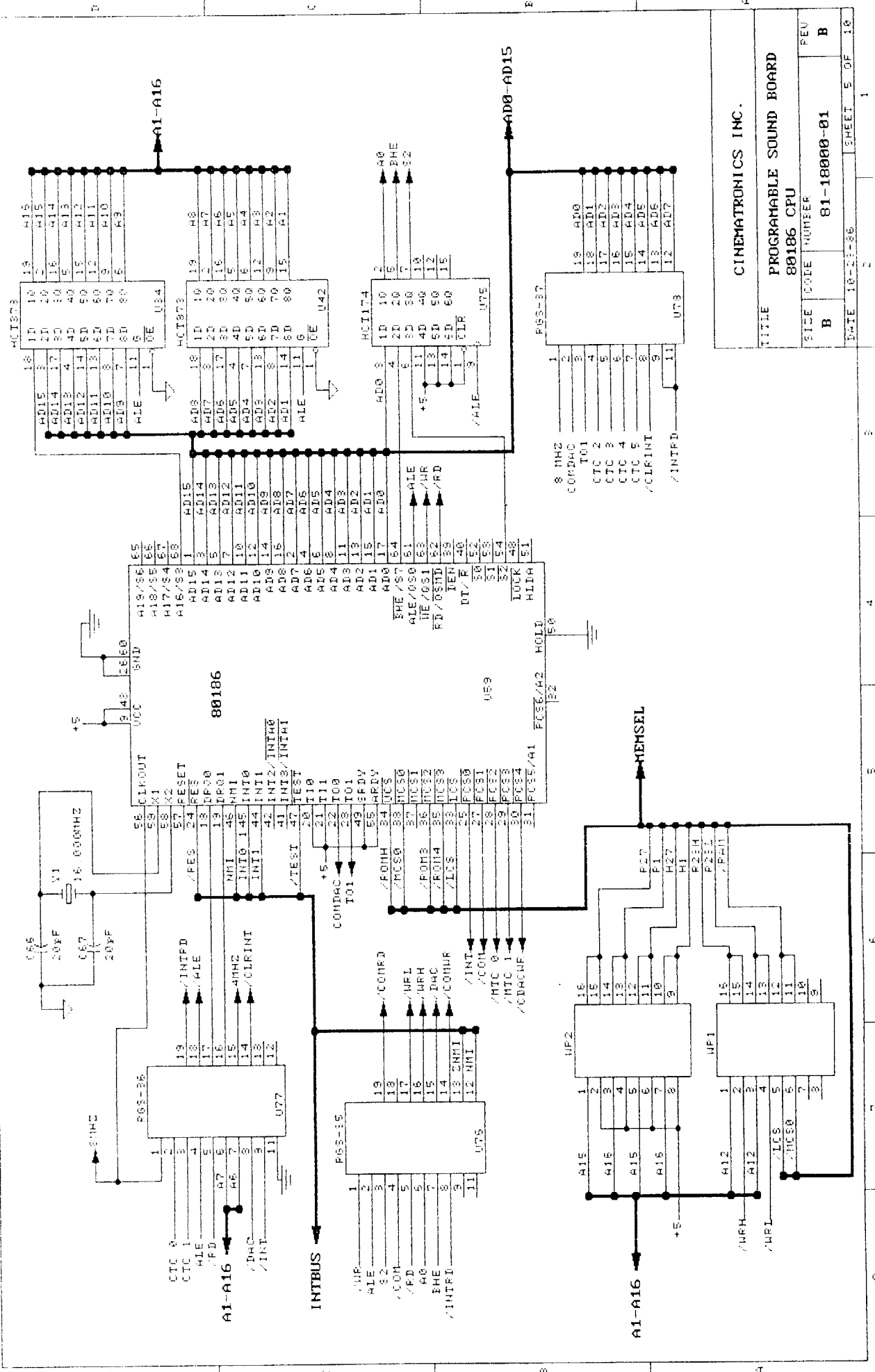

CINEMATRONICS INC.		
TITLE PROGRAMMABLE SOUND BOARD		
80186 CPU		
SIZE B	CODE NUMBER 81-18000-01	REV B
DATE 10-23-86	SHEET 5 OF 10	

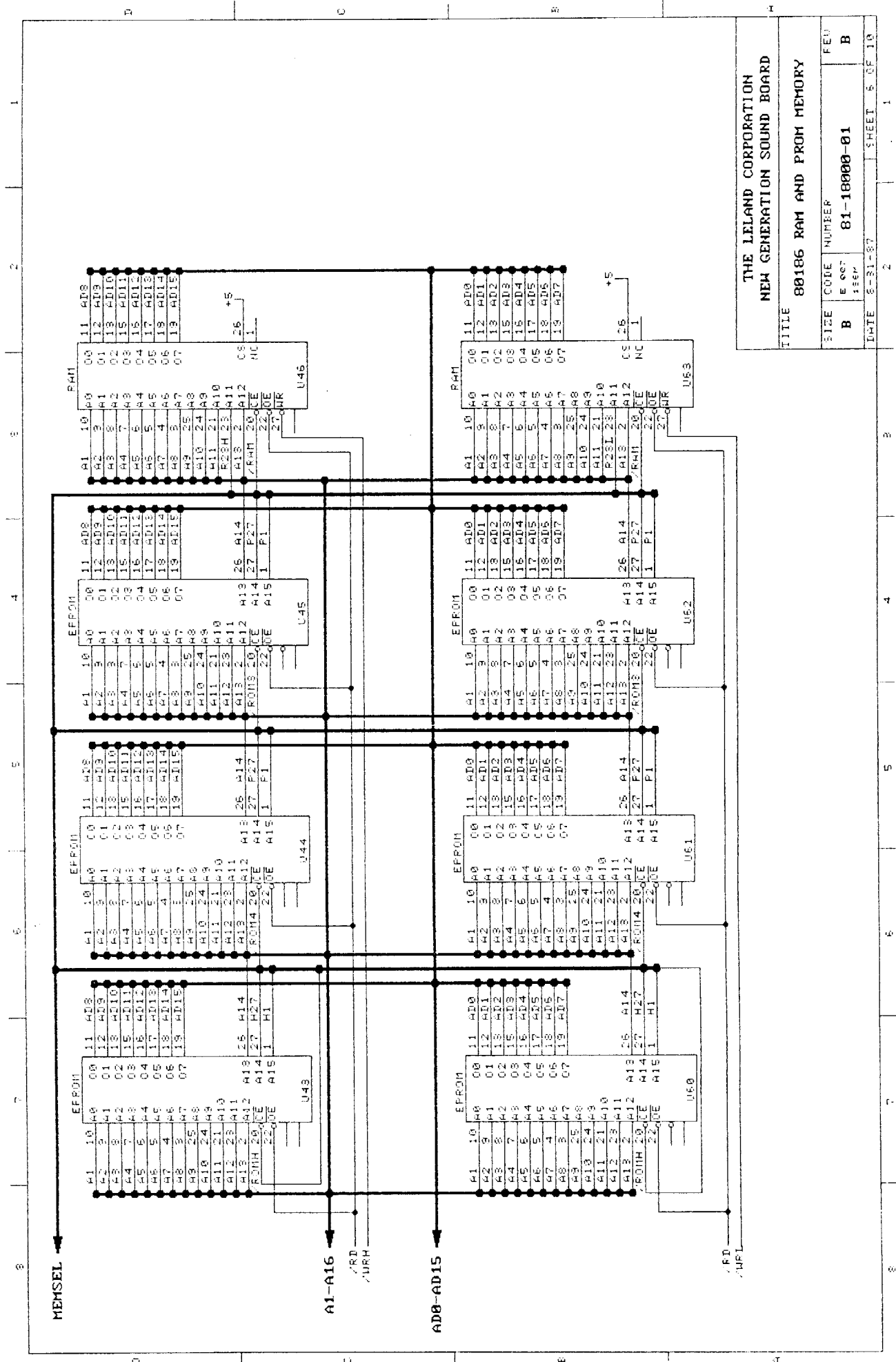

THE IRLAND CORPORATION NEW GENERATION SOUND BOARD		
TITLE 80186 RAM AND PROM MEMORY		
SIZE	CODE NUMBER	REV
B	81-10000-01	B
DATE	6-21-87	SHEET 6 OF 10

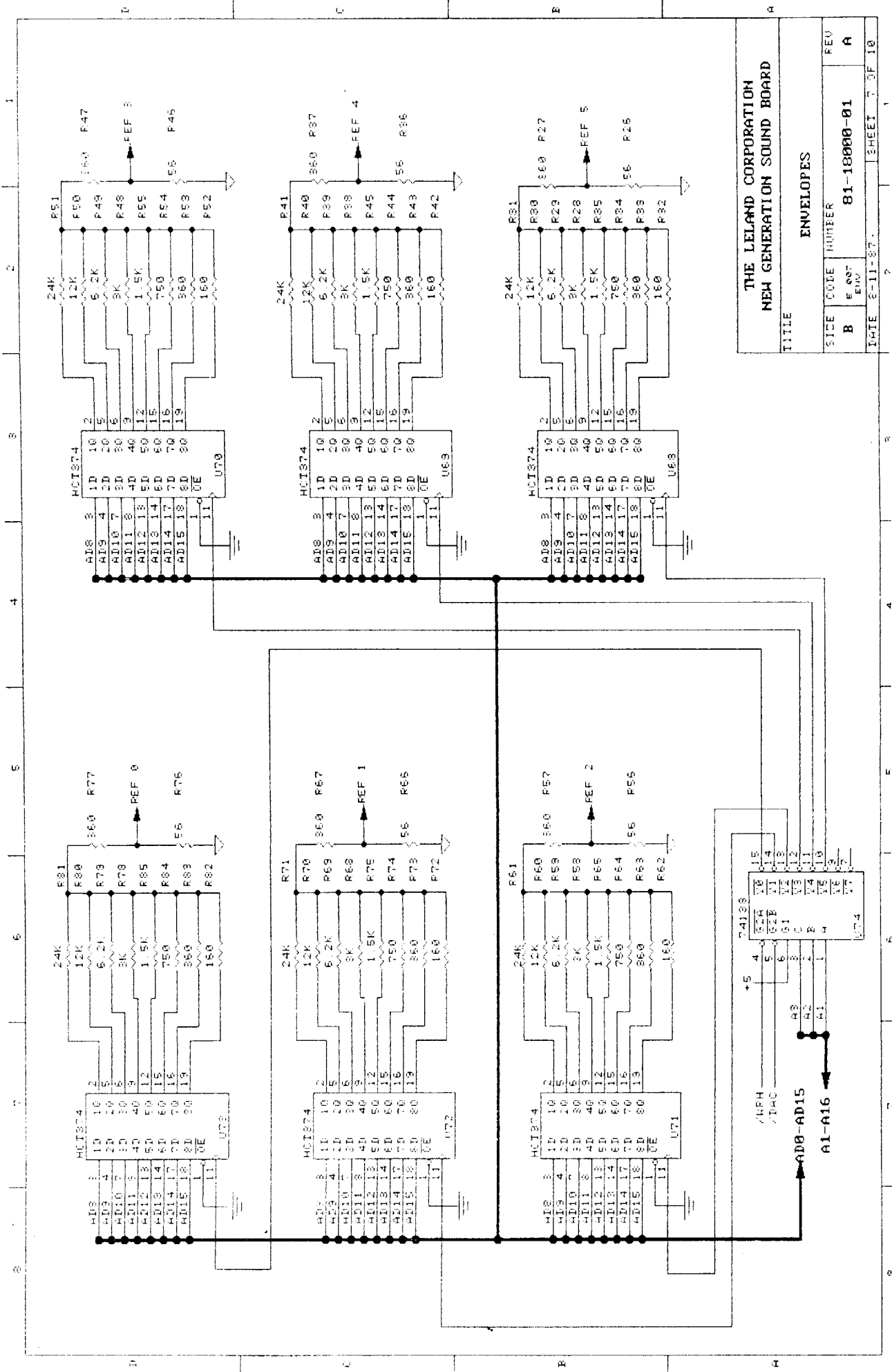

THE LELAND CORPORATION
 NEW GENERATION SOUND BOARD

TITLE

SIZE	CODE	NUMBER	REV
B	E 007	81-18000-01	A

DATE 8-11-87 SHEET 1 OF 10

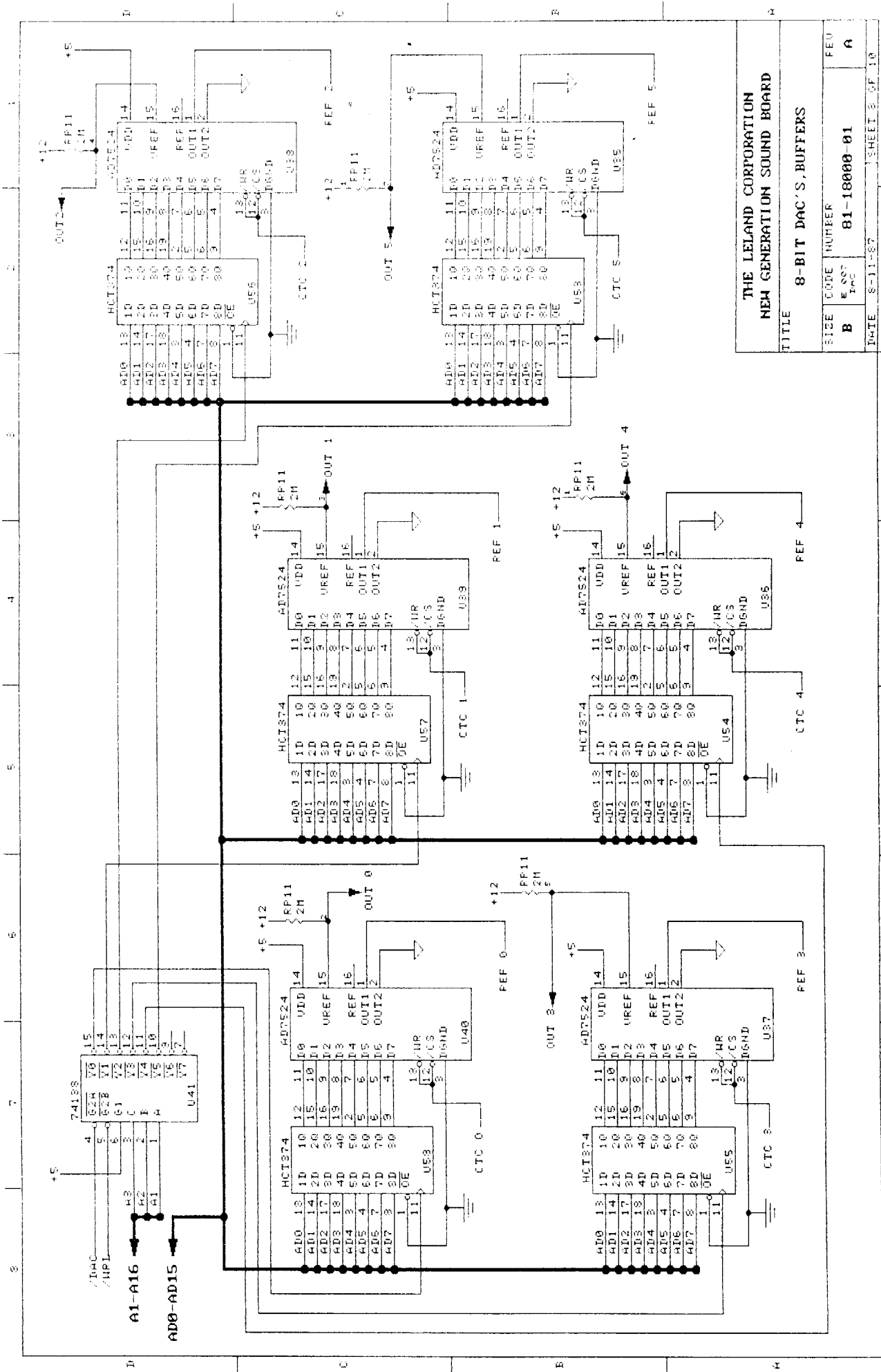

TITLE
THE LELAND CORPORATION
NEW GENERATION SOUND BOARD

SIZE	CODE	NUMBER	FEU
B	E	81-18000-01	A
DATE 8-11-87			SHEET 2 OF 10

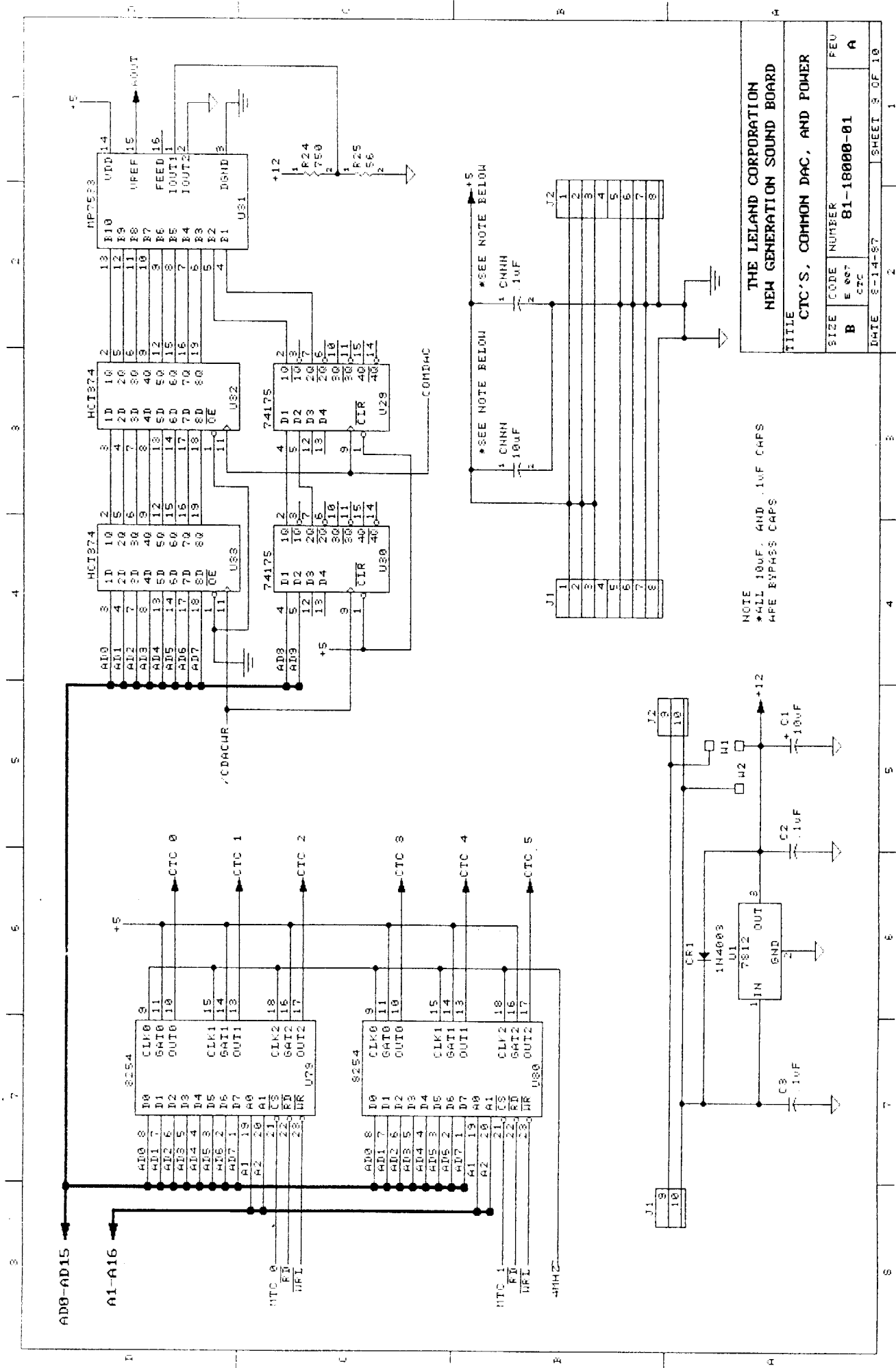

NOTE
*ALL 100F AND 1uF CAPS
ARE EXPRESS CAPS

*SEE NOTE BELOW
1 1CNH
2 10uF

*SEE NOTE BELOW
1 1CNH
2 1uF

J1
1
2
3
4
5
6
7
8

J2
1
2
3
4
5
6
7
8

THE LELAND CORPORATION
NEW GENERATION SOUND BOARD

SIZE CODE NUMBER FEU
B E 007 81-18000-01 A

DATE 8-14-87 SHEET 3 OF 10

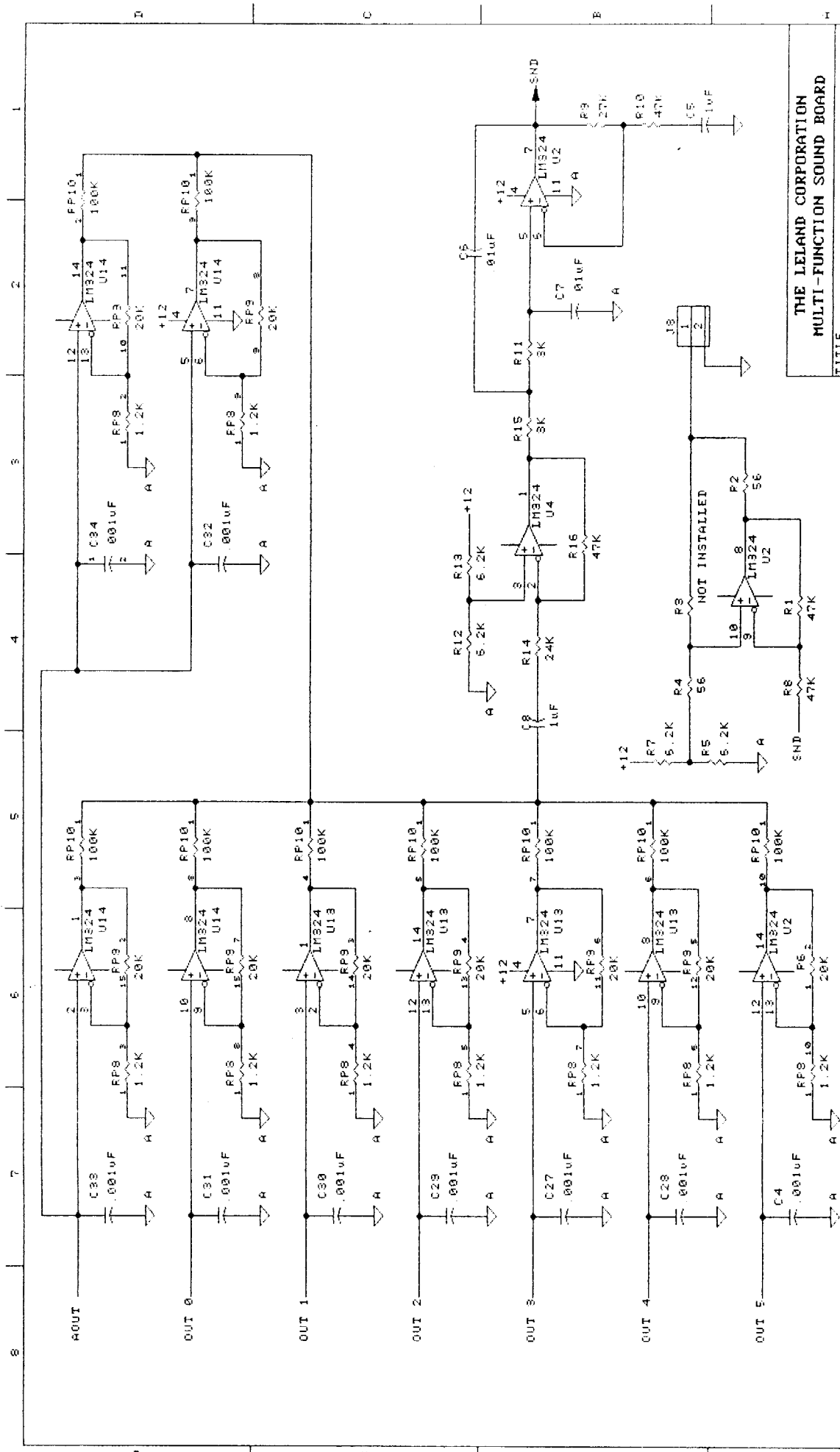

TITLE		
THE LELAND CORPORATION MULTI-FUNCTION SOUND BOARD		
SIZE	CODE	NUMBER
B	E 007	81-18000-01
DATE		8-11-87
SHEET		10 OF 10

PROBABILITY
1. ALL DIMENSIONS ARE PRELIMINARY
2. DIMENSIONS IN AREAS
NOT TO BE REPRODUCED OR
CONSIDERED AS PART OF THE
NOR REPRODUCED OR CONSIDERED AS
PART OF THE ORIGINAL DRAWING

P1-P6, KEY PIN: OMIT

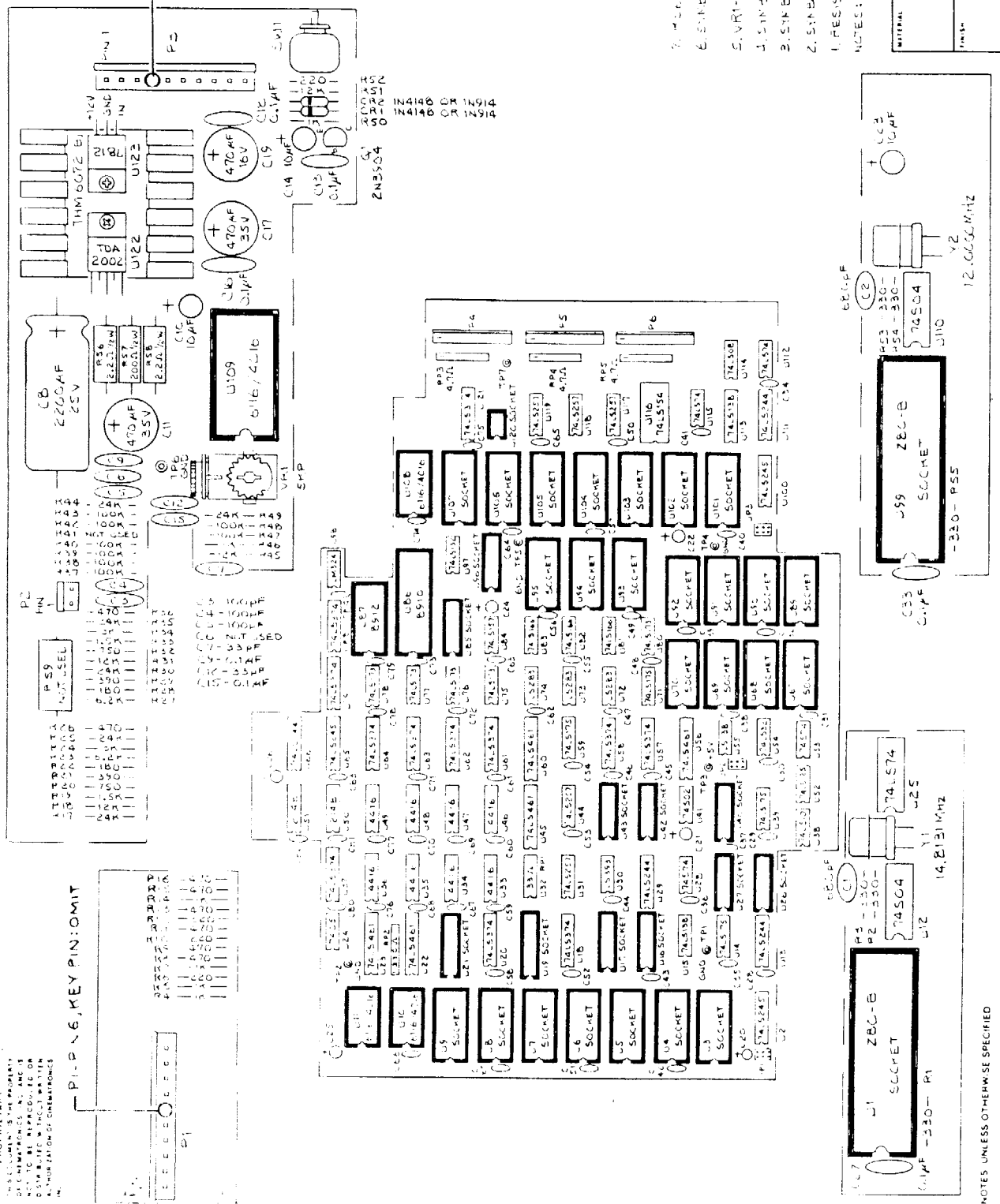

P3-P14 KEY PIN: OMIT

4	3000	4	605
5	220	5	400
6	220	6	400
7	220	7	400
8	220	8	400
9	220	9	400
10	220	10	400
11	220	11	400
12	220	12	400
13	220	13	400
14	220	14	400
15	220	15	400
16	220	16	400
17	220	17	400
18	220	18	400
19	220	19	400
20	220	20	400
21	220	21	400
22	220	22	400
23	220	23	400
24	220	24	400
25	220	25	400
26	220	26	400
27	220	27	400
28	220	28	400
29	220	29	400
30	220	30	400

1. RESISTOR VALUES ARE GIVEN IN OHMS UNLESS OTHERWISE SPECIFIED
2. SYMBOLS FOR CAPACITORS ARE: C1, C2, C3, C4, C5, C6, C7, C8, C9, C10, C11, C12, C13, C14
3. SYMBOLS FOR INDUCTORS ARE: L1, L2, L3, L4, L5, L6, L7, L8, L9, L10, L11, L12, L13, L14
4. SYMBOLS FOR TRANSISTORS ARE: T1, T2, T3, T4, T5, T6, T7, T8, T9, T10, T11, T12, T13, T14
5. SYMBOLS FOR DIODES ARE: D1, D2, D3, D4, D5, D6, D7, D8, D9, D10, D11, D12, D13, D14
6. SYMBOLS FOR INTEGRATED CIRCUITS ARE: U1, U2, U3, U4, U5, U6, U7, U8, U9, U10
7. SYMBOLS FOR CONNECTORS ARE: J1, J2, J3, J4, J5, J6
8. SYMBOLS FOR SWITCHES ARE: S1, S2, S3, S4, S5, S6, S7, S8, S9, S10, S11, S12, S13, S14

DATE	BY
10/26/87	
PROJECT	DWG TITLE
THE LELAND CORP.	CINEMAT MAIN LOGIC
DATE	BY
DATE	BY
DATE	BY
DATE	BY
DATE	BY

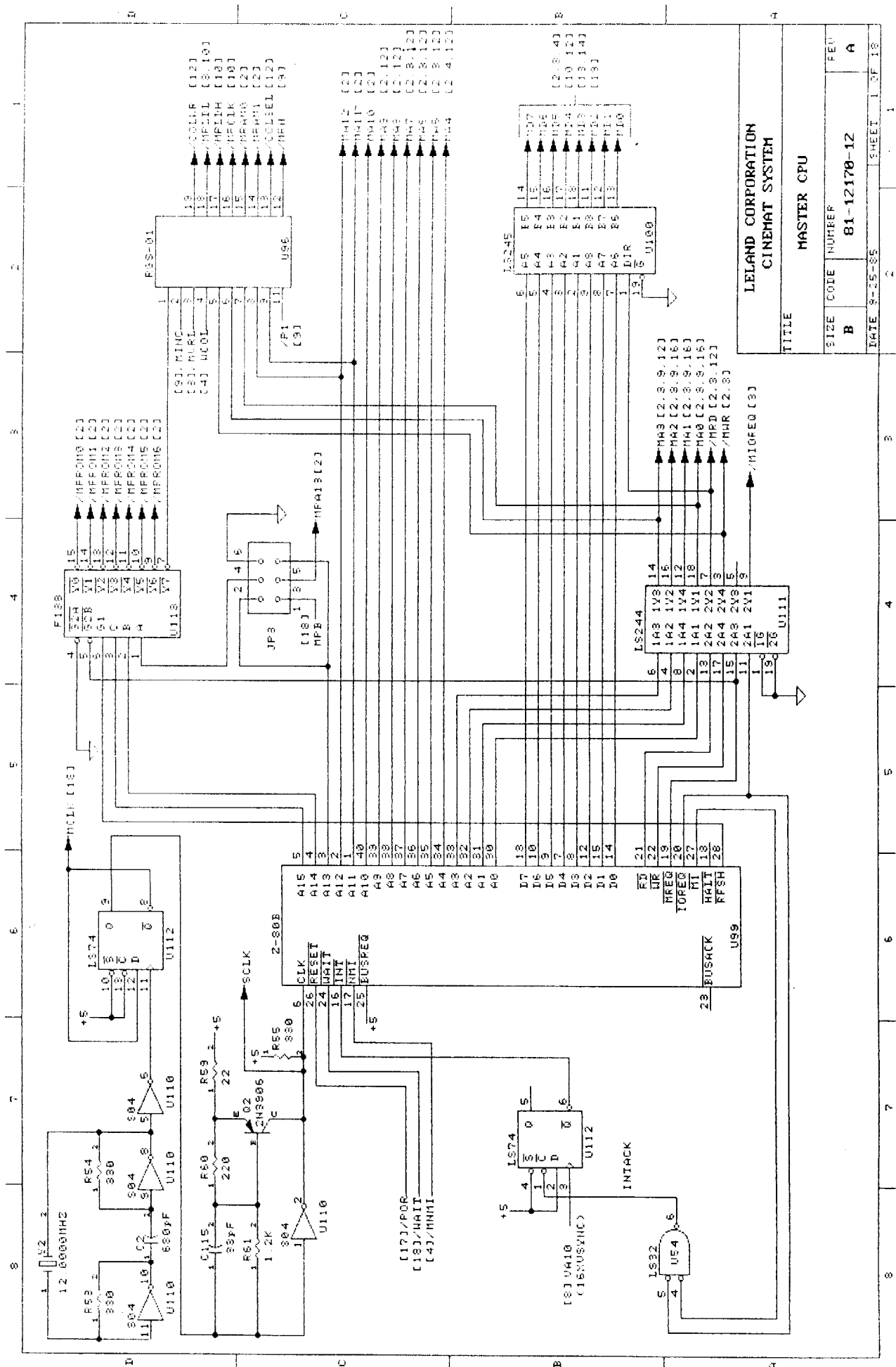

LELAND CORPORATION
CINEMAT SYSTEM

TITLE
MASTER CPU

SIZE CODE NUMBER
B 81-12170-12

DATE 9-25-88 SHEET 1 OF 13

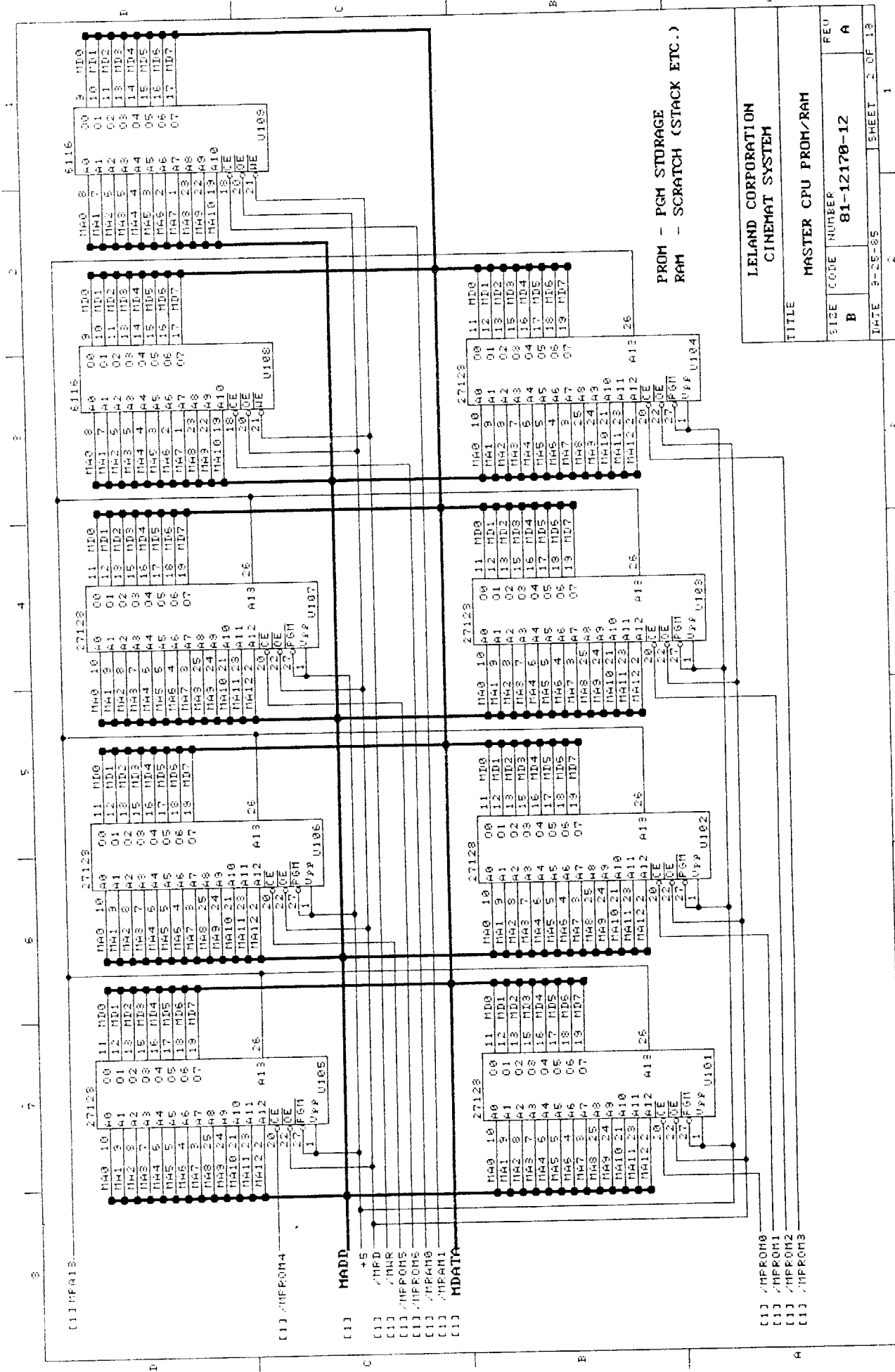

PROM - PGM STORAGE
RAM - SCRATCH (STACK ETC.)

LELAND CORPORATION
CINEMAT SYSTEM

TITLE	
SIZE	FEU
B	A
NUMBER	
81-12170-12	
DATE	SHEET
3-25-85	2 OF 13

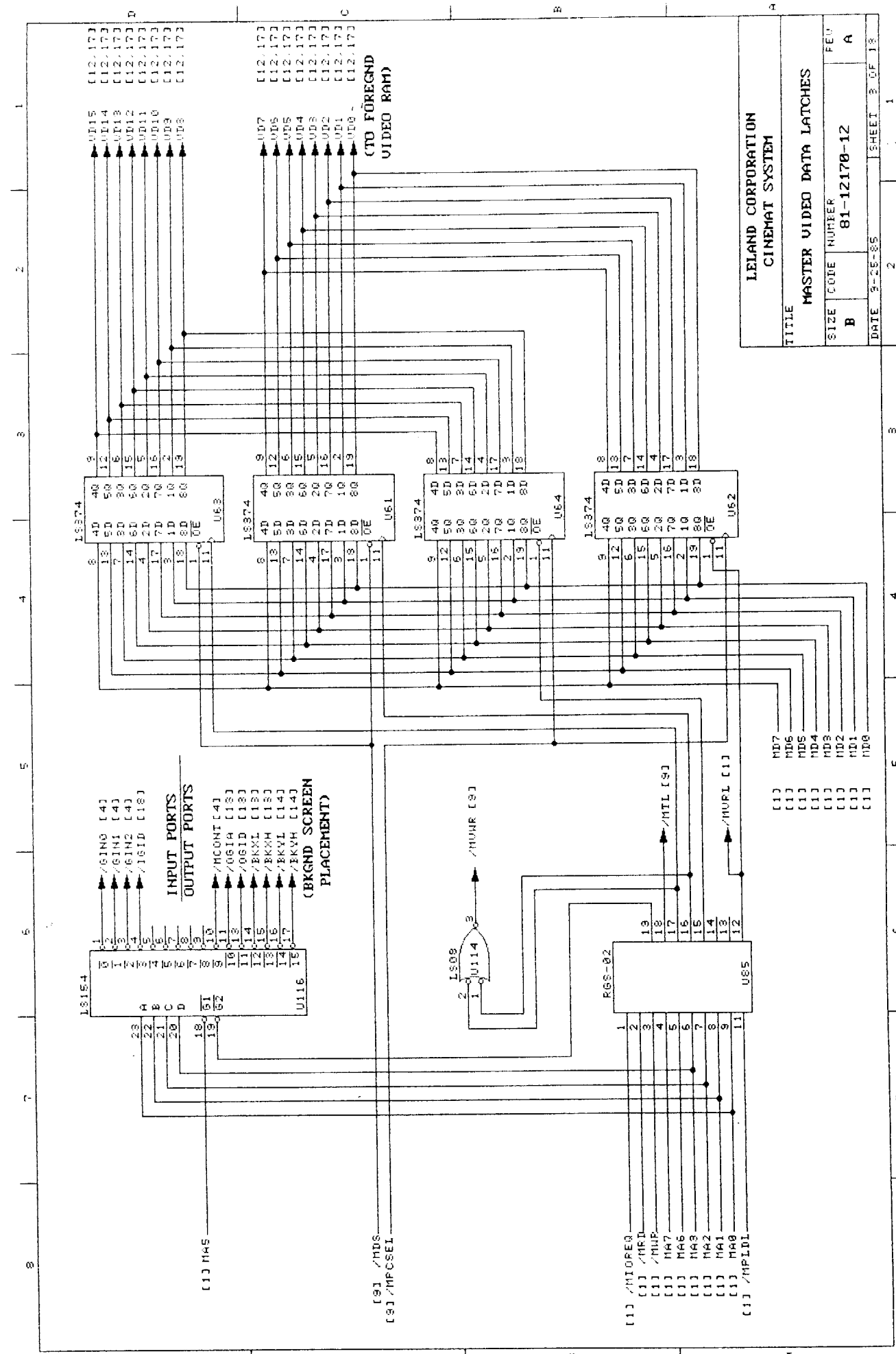

LELAND CORPORATION CINEMAT SYSTEM	
TITLE MASTER VIDEO DATA LATCHES	
SIZE B	NUMBER 81-12170-12
FEU A	
DATE 3-25-85	SHEET 3 OF 13

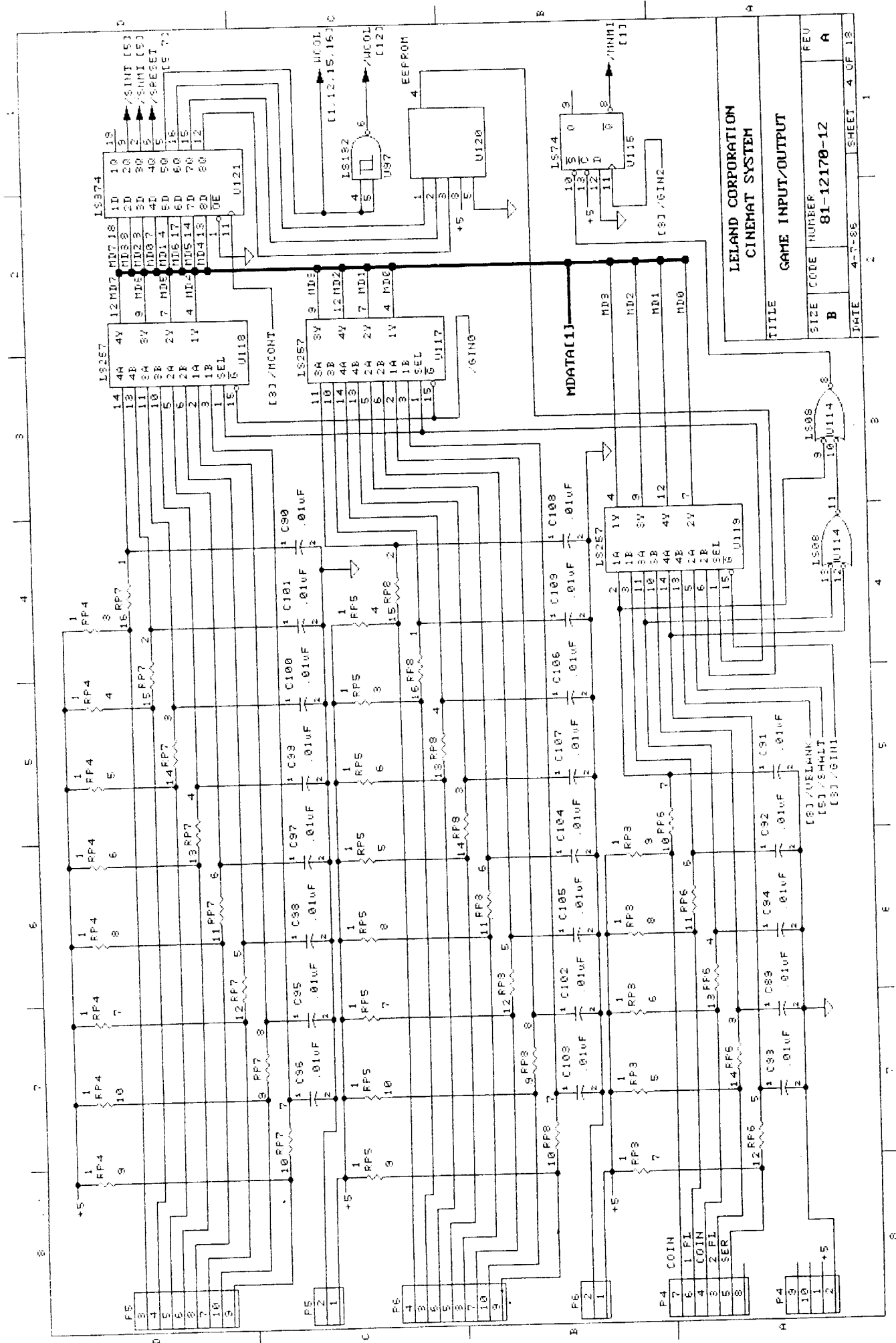

LELAND CORPORATION
CINEHAT SYSTEM

TITLE	GAME INPUT/OUTPUT		
SIZE	CODE NUMBER	FEU	A
B	81-12178-12		
DATE	4-7-85	SHEET	4 OF 13

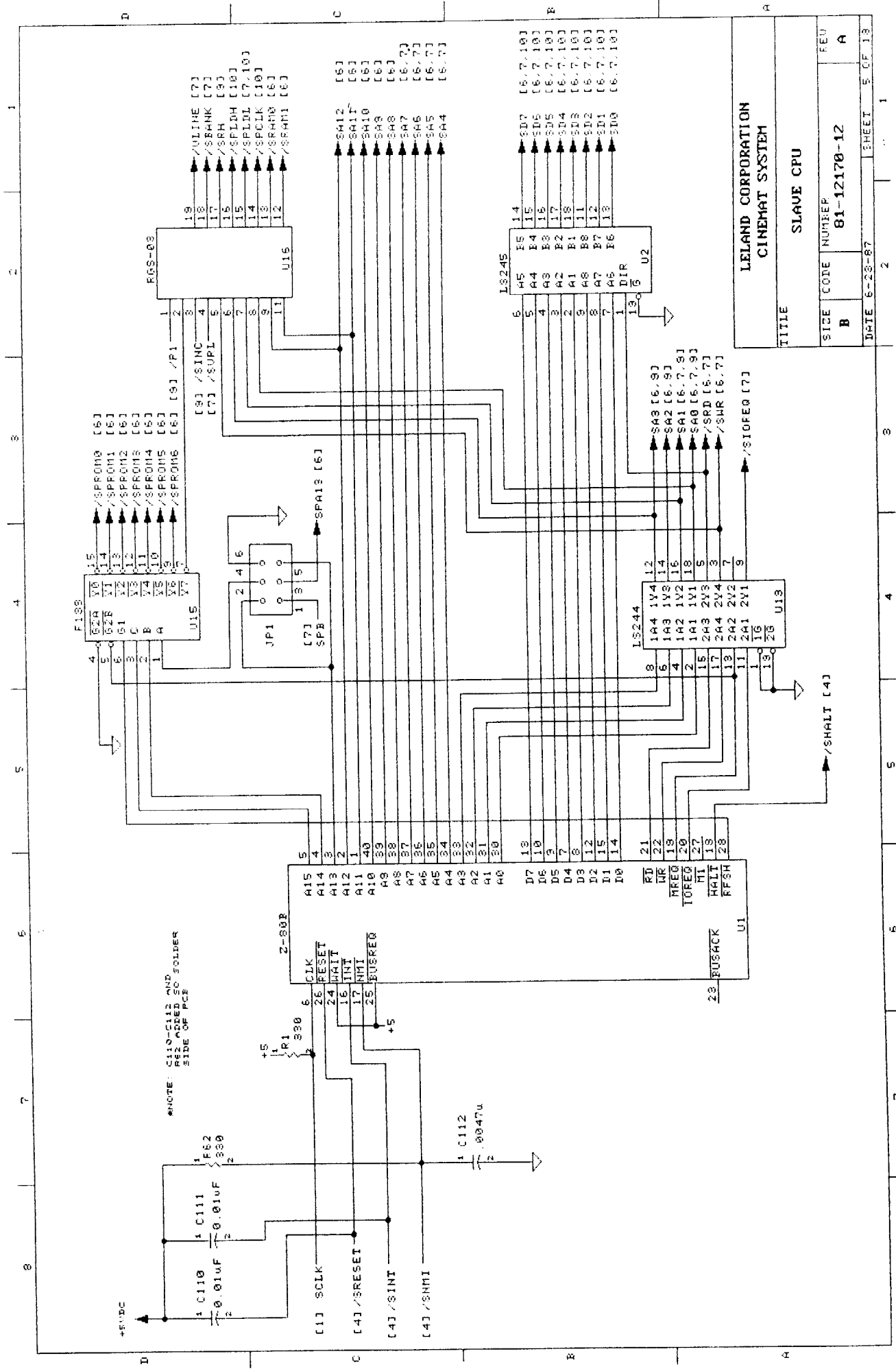

LELAND CORPORATION CINEMAT SYSTEM		
TITLE		
SIZE	CODE	FEU
B		A
NUMBER	81-12170-12	
DATE	6-23-87	SHEET 5 OF 13

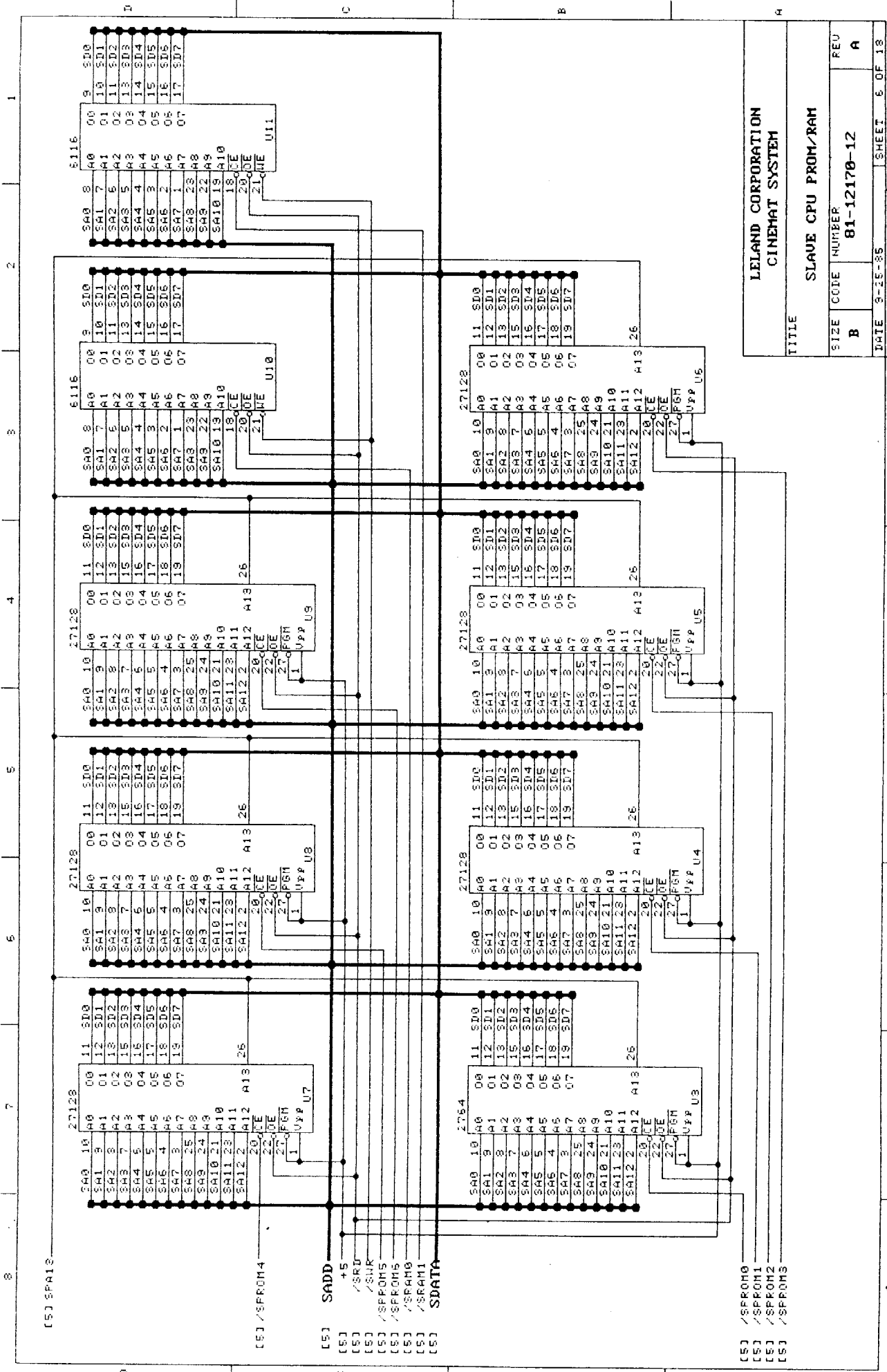

TITLE	
LELAND CORPORATION CINEMAT SYSTEM	
SIZE	FEU
B	A
CODE NUMBER	
81-12170-12	
DATE 3-25-85	SHEET 5 OF 18

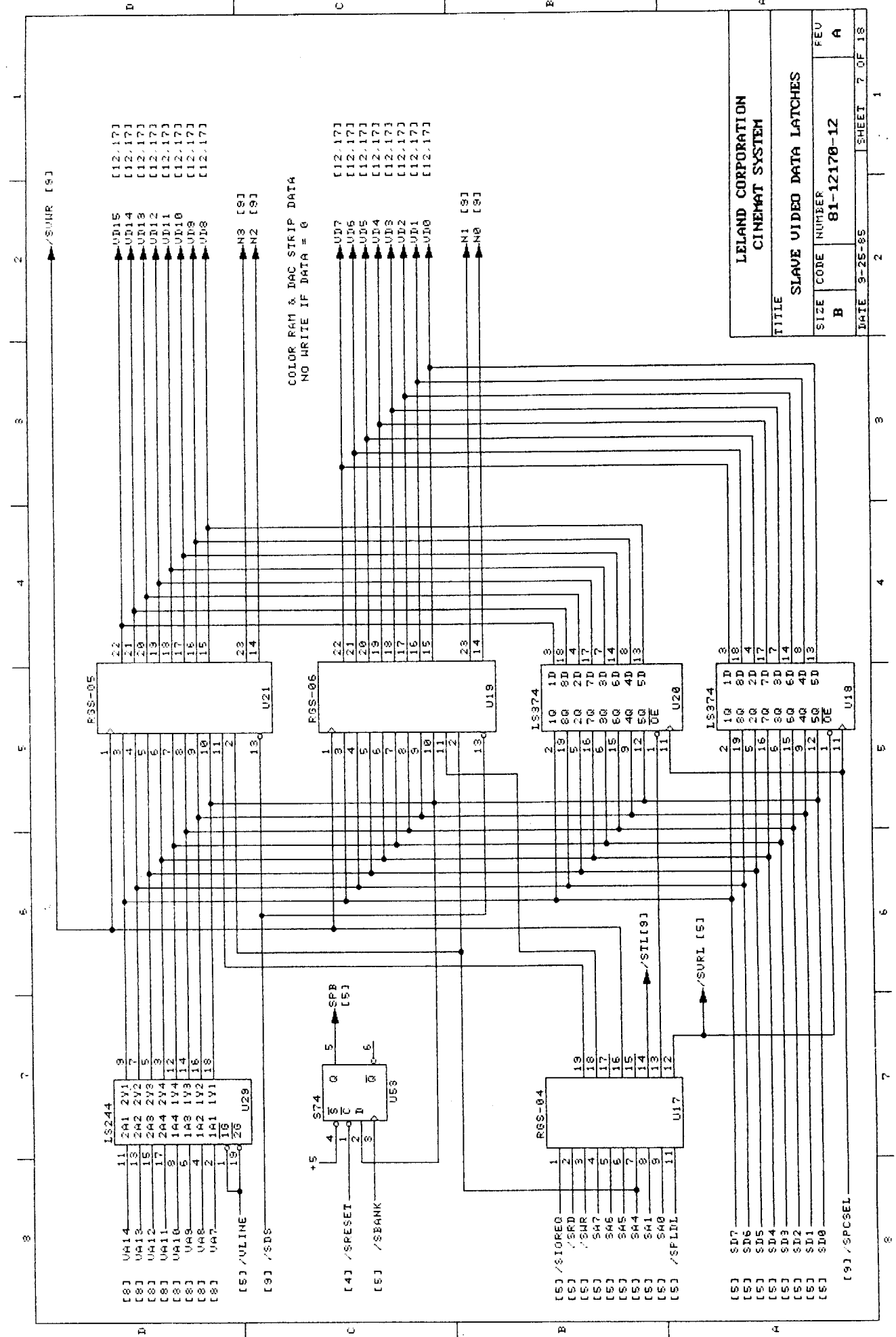

COLOR RAM & DAC STRIP DATA
NO WRITE IF DATA = 0

LELAND CORPORATION CINEMAT SYSTEM	
TITLE SLAVE VIDEO DATA LATCHES	
SIZE B	NUMBER 81-12178-12
DATE 9-25-85	SHEET 7 OF 18

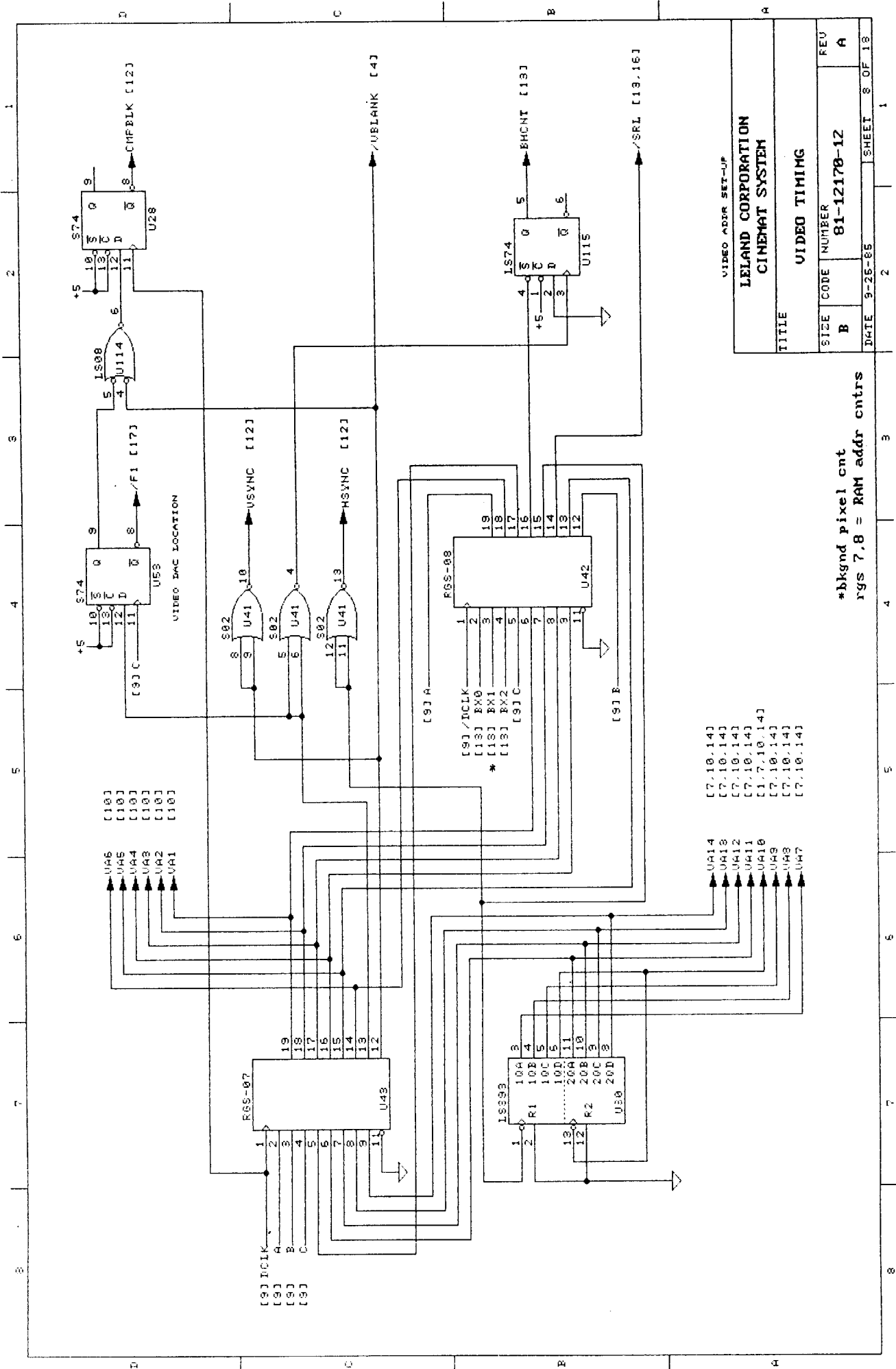

VIDEO ADDR SET-UP	
LELAND CORPORATION CINEMAT SYSTEM	
TITLE	
SIDE	REU
CODE	NUMBER
B	81-12178-12
DATE	SHEET
9-26-85	8 OF 13

*bkgrd pixel cnt
r/s 7.8 = RAM addr cnts

- [7,10,14]
- [7,10,14]
- [7,10,14]
- [7,10,14]
- [1,7,10,14]
- [7,10,14]
- [7,10,14]

- U414
- U418
- U412
- U411
- U416
- U48
- U48
- U47

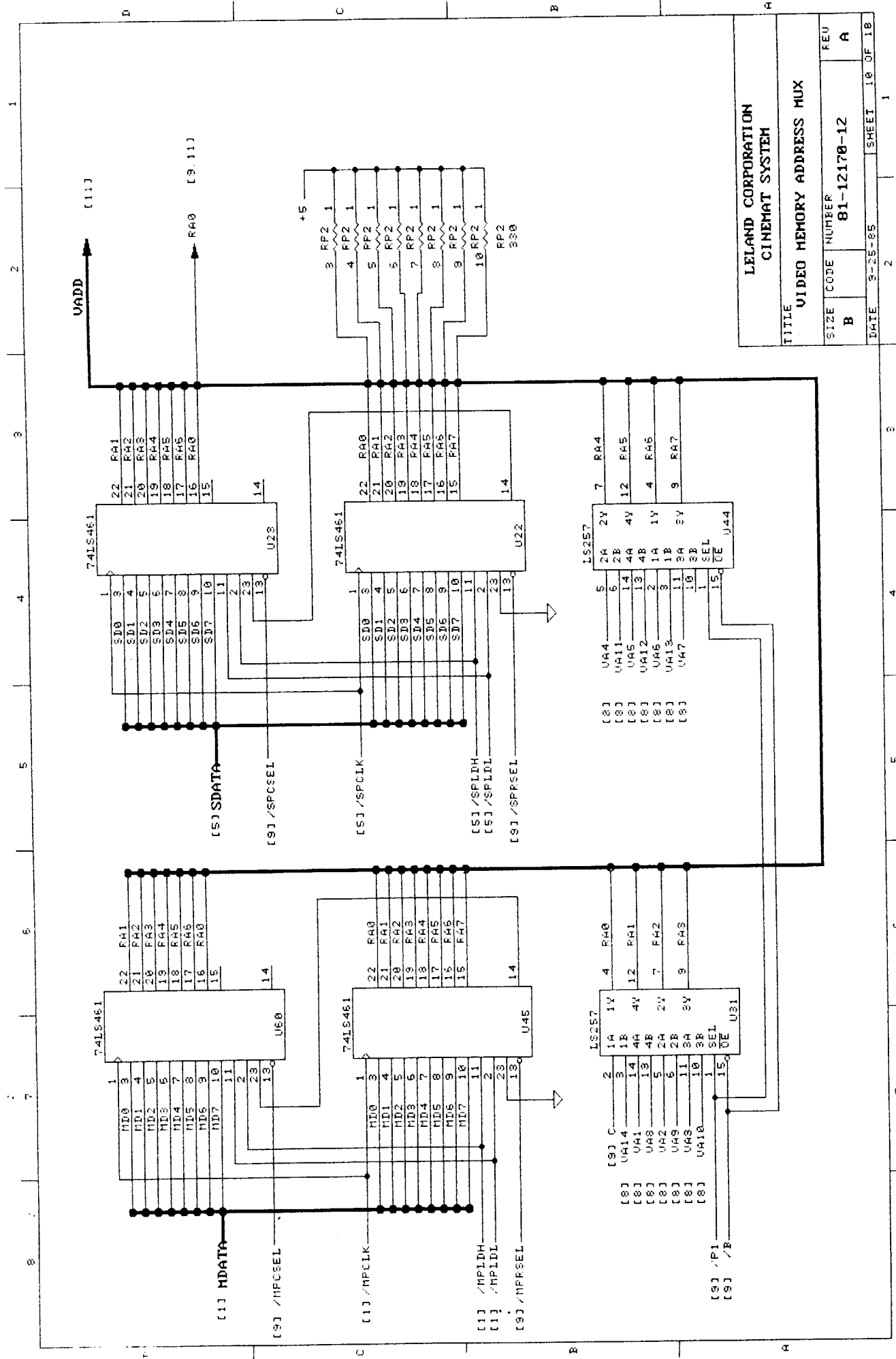

**LELAND CORPORATION
CINEMAT SYSTEM**

**TITLE
VIDEO MEMORY ADDRESS MUX**

SIZE	CODE	NUMBER	REV
B		81-12178-12	A
DATE 8-25-85			SHEET 10 OF 18

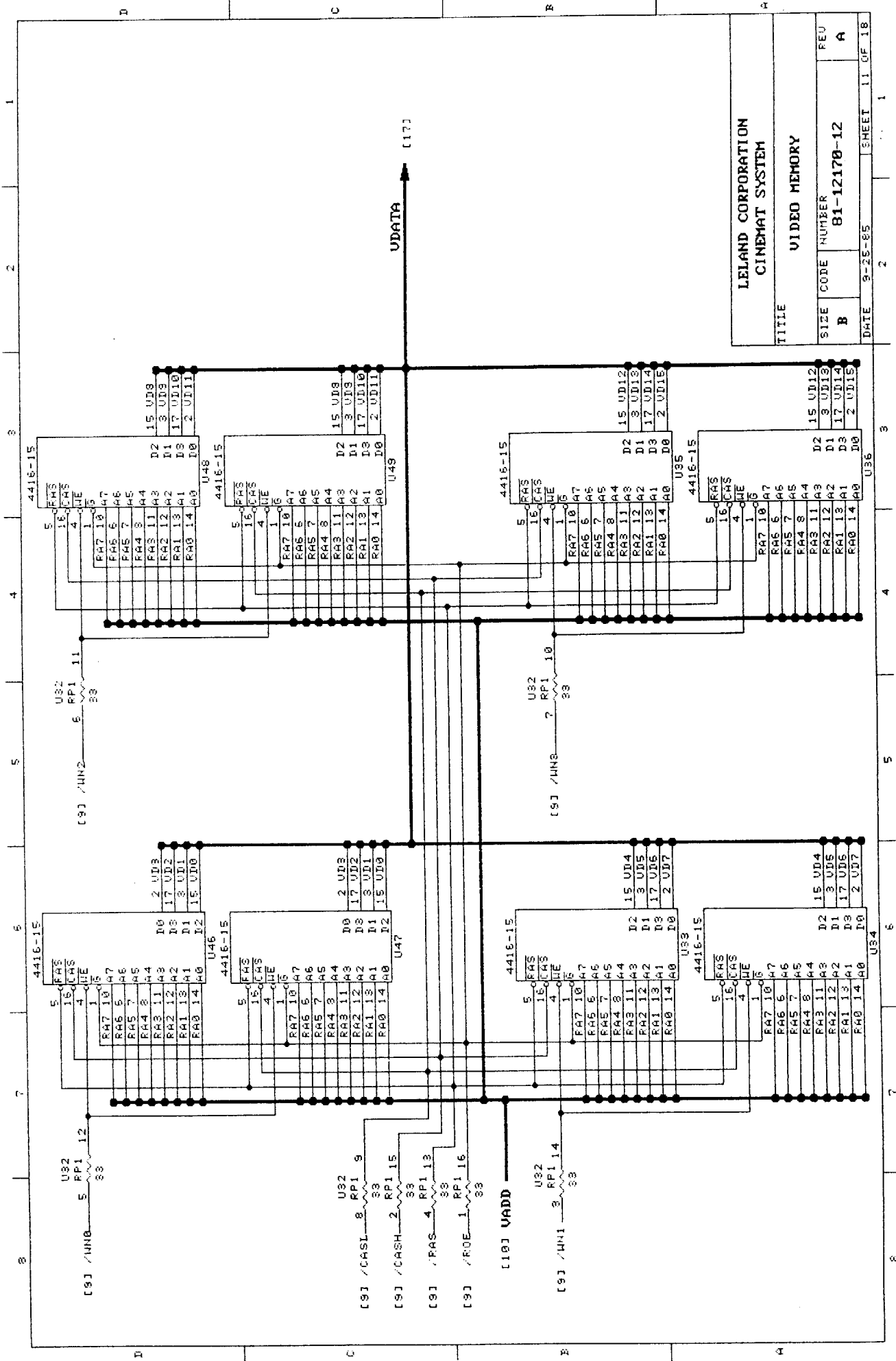

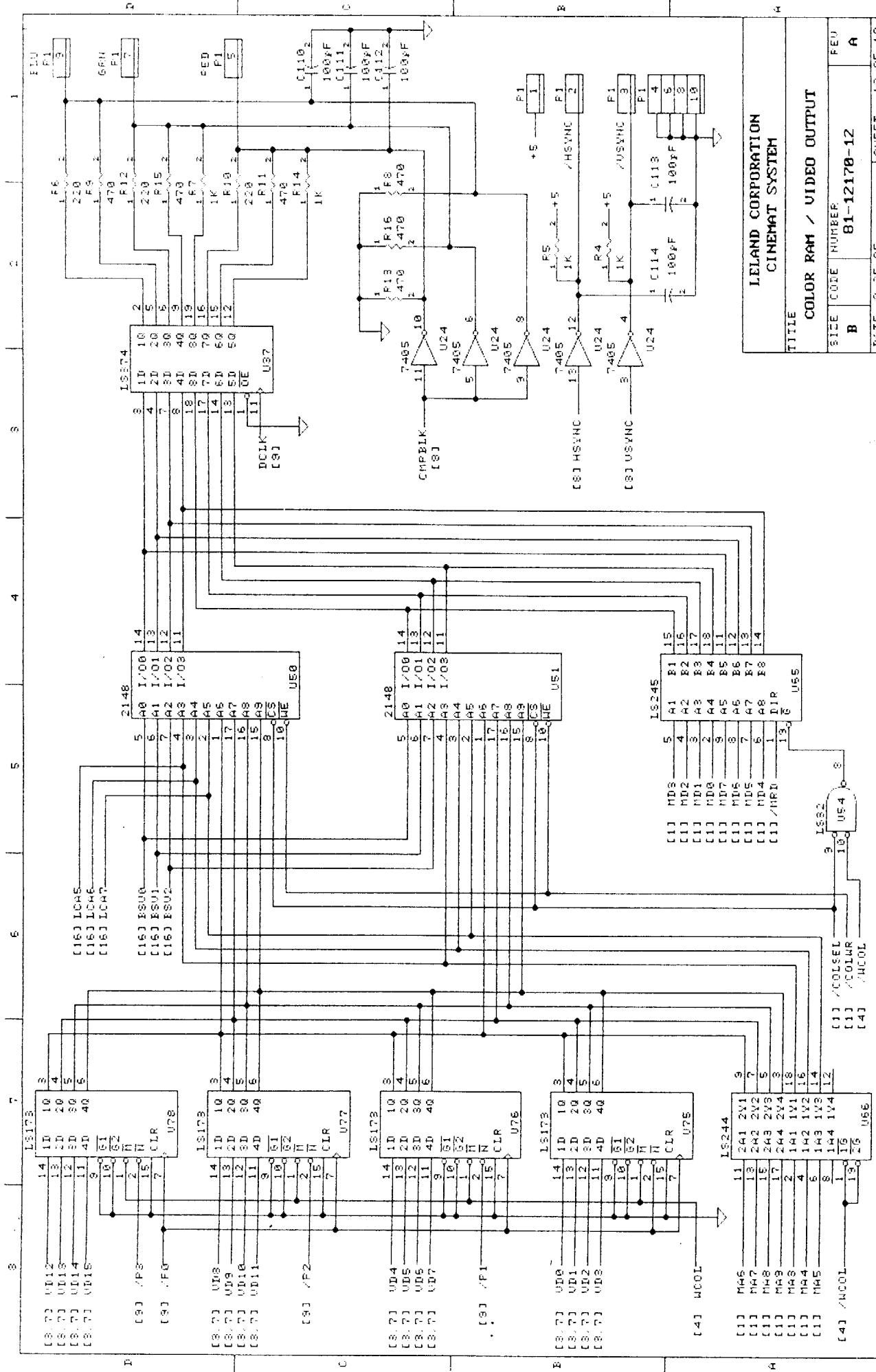

TITLE	
LELAND CORPORATION CINEMAT SYSTEM	
SIZE	FEU
CODE	A
NUMBER	
B	81-12170-12
DATE	SHEET 12 OF 18
3-25-85	2

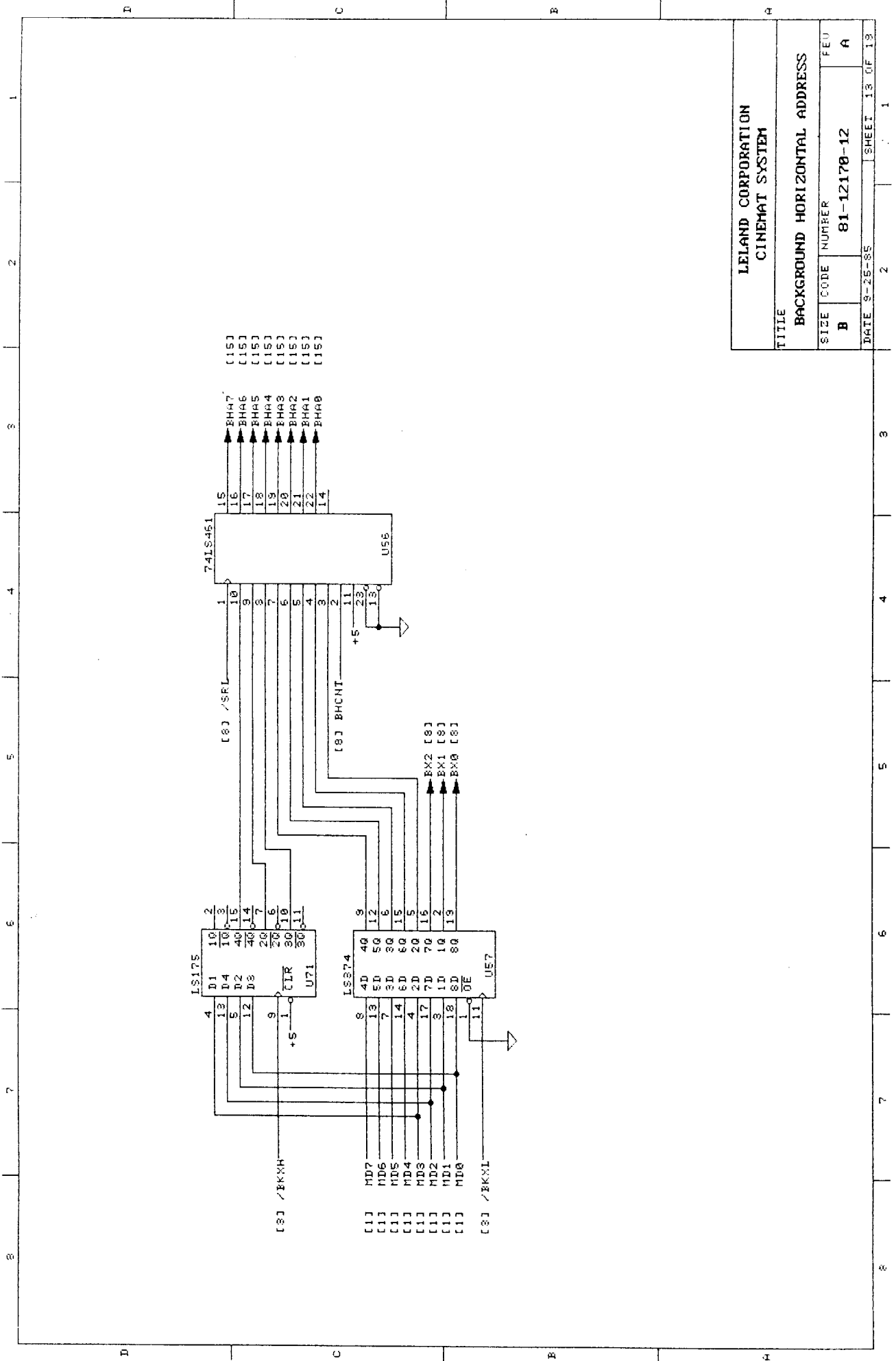

LELAND CORPORATION CINEMAT SYSTEM	
TITLE BACKGROUND HORIZONTAL ADDRESS	
SIZE B	CODE NUMBER 81-12170-12
DATE 9-25-55	FEU A
SHEET 13 OF 13	

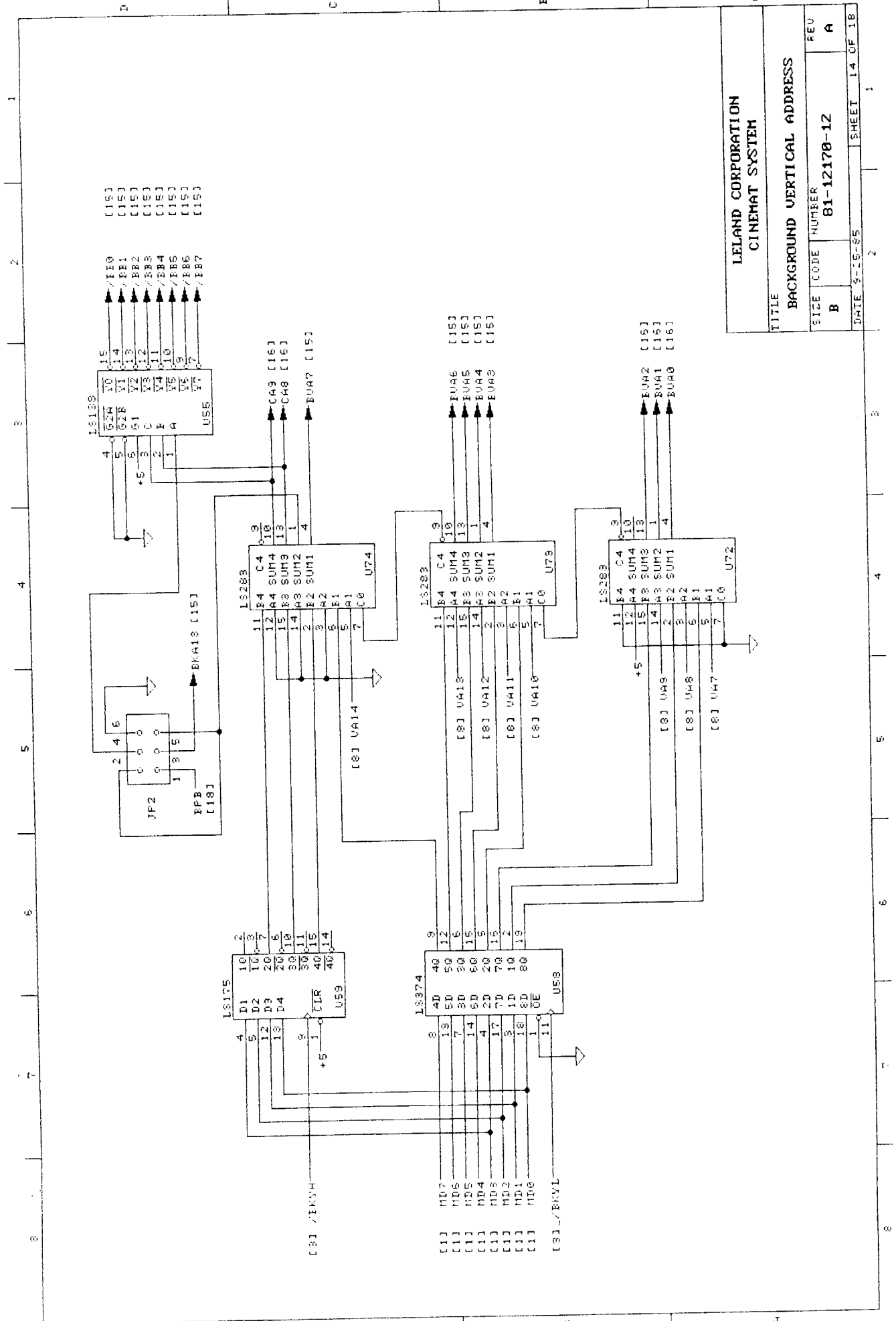

TITLE		LLELAND CORPORATION CINEMAT SYSTEM	
BACKGROUND VERTICAL ADDRESS			
SIZE	CODE	NUMBER	FEU
B		81-12170-12	A
DATE 5-15-55		SHEET 14 OF 18	

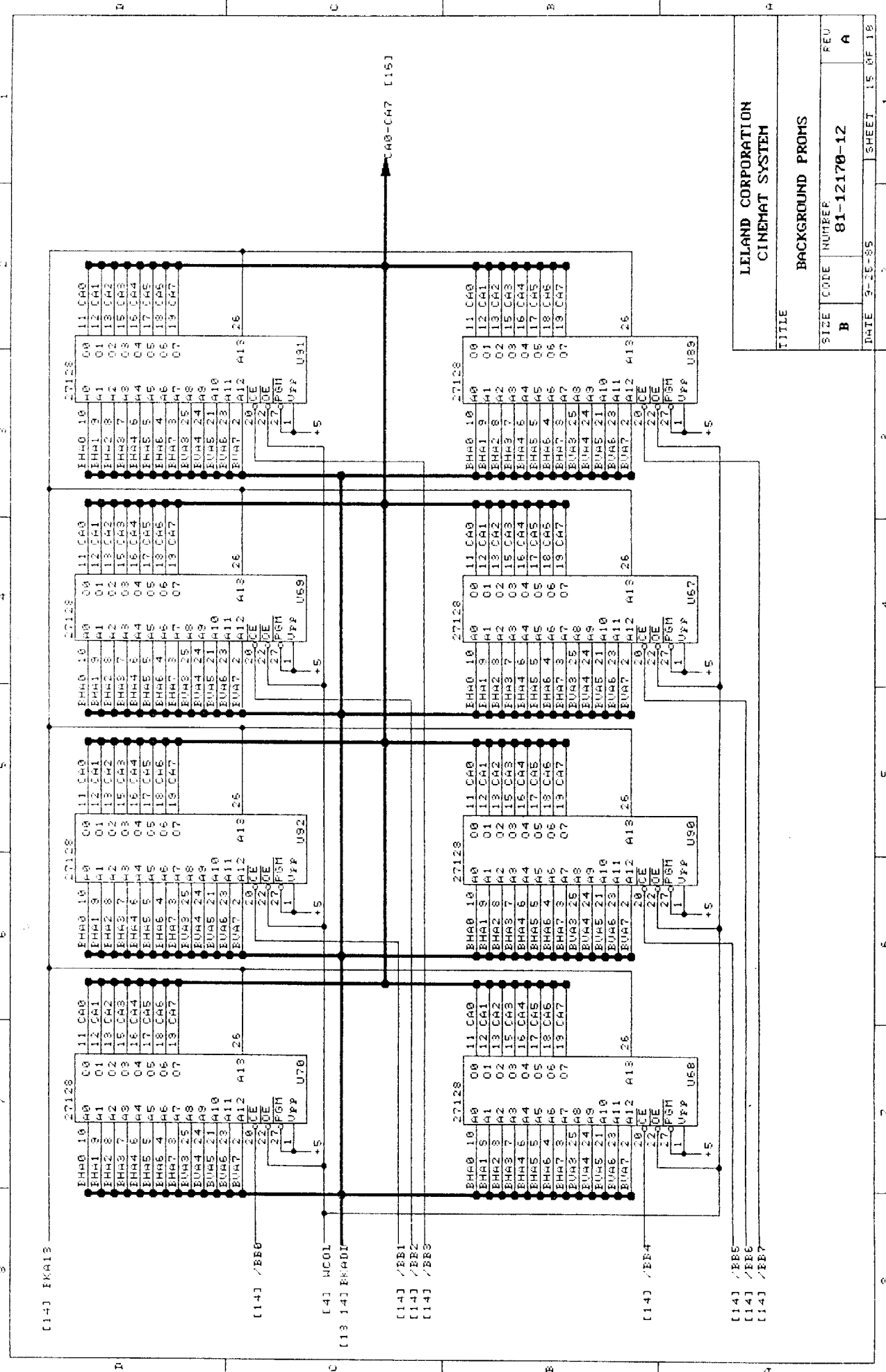

LELAND CORPORATION
CINEMAT SYSTEM

BACKGROUND PROMS

TITLE	SIZE	CODE	NUMBER	REV
	B		81-12170-12	A
DATE	9-25-85		SHEET	15 OF 18

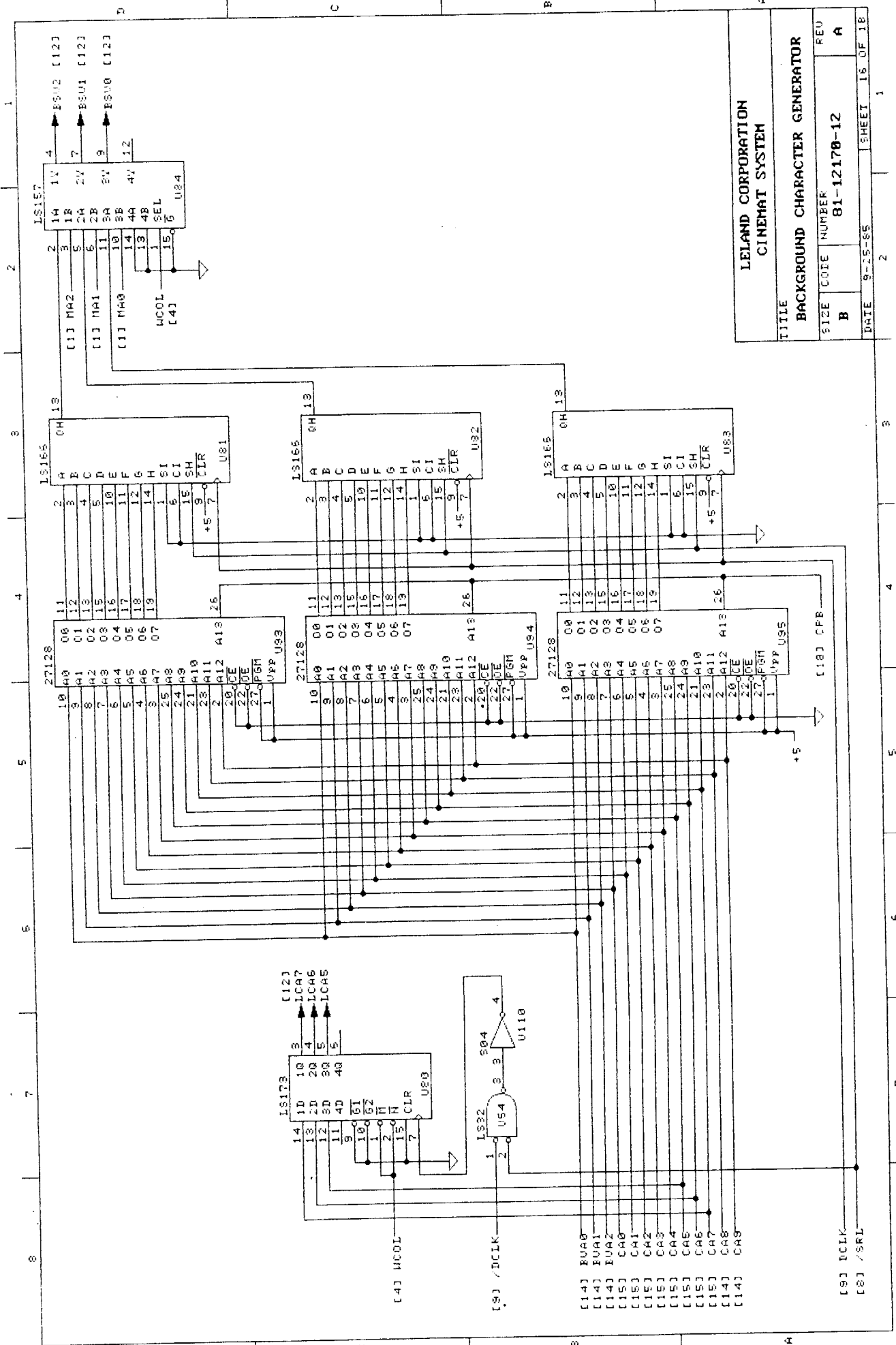

LELAND CORPORATION CINEMAT SYSTEM	
TITLE BACKGROUND CHARACTER GENERATOR	
SIZE B	CODE NUMBER 81-12170-12
DATE 9-25-55	SHEET 16 OF 18
	REV A

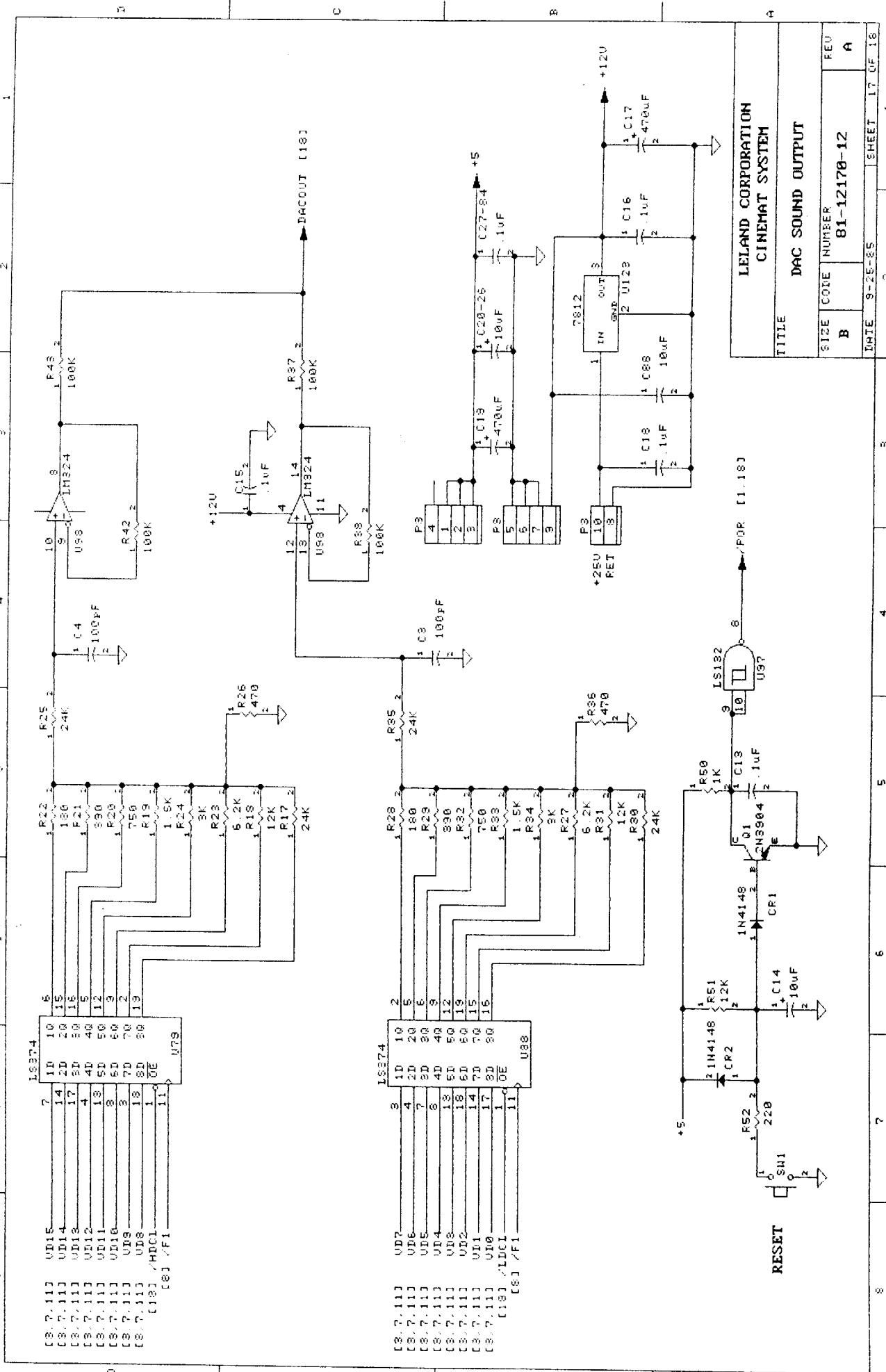

LS374

7	10
8	11
9	12
10	13
11	14
12	15
13	16
14	17
15	18
16	19
17	20
18	21
19	22
20	23
21	24
22	25
23	26
24	27
25	28
26	29
27	30
28	31
29	32
30	33
31	34
32	35
33	36
34	37
35	38
36	39
37	40
38	41
39	42
40	43
41	44
42	45
43	46
44	47
45	48
46	49
47	50
48	51
49	52
50	53
51	54
52	55
53	56
54	57
55	58
56	59
57	60
58	61
59	62
60	63
61	64
62	65
63	66
64	67
65	68
66	69
67	70
68	71
69	72
70	73
71	74
72	75
73	76
74	77
75	78
76	79
77	80
78	81
79	82
80	83
81	84
82	85
83	86
84	87
85	88
86	89
87	90
88	91
89	92
90	93
91	94
92	95
93	96
94	97
95	98
96	99
97	100
98	101
99	102
100	103
101	104
102	105
103	106
104	107
105	108
106	109
107	110
108	111
109	112
110	113
111	114
112	115
113	116
114	117
115	118
116	119
117	120
118	121
119	122
120	123
121	124
122	125
123	126
124	127
125	128
126	129
127	130
128	131
129	132
130	133
131	134
132	135
133	136
134	137
135	138
136	139
137	140
138	141
139	142
140	143
141	144
142	145
143	146
144	147
145	148
146	149
147	150
148	151
149	152
150	153
151	154
152	155
153	156
154	157
155	158
156	159
157	160
158	161
159	162
160	163
161	164
162	165
163	166
164	167
165	168
166	169
167	170
168	171
169	172
170	173
171	174
172	175
173	176
174	177
175	178
176	179
177	180
178	181
179	182
180	183
181	184
182	185
183	186
184	187
185	188
186	189
187	190
188	191
189	192
190	193
191	194
192	195
193	196
194	197
195	198
196	199
197	200

LS374

3	2
4	3
5	4
6	5
7	6
8	7
9	8
10	9
11	10
12	11
13	12
14	13
15	14
16	15
17	16
18	17
19	18
20	19
21	20
22	21
23	22
24	23
25	24
26	25
27	26
28	27
29	28
30	29
31	30
32	31
33	32
34	33
35	34
36	35
37	36
38	37
39	38
40	39
41	40
42	41
43	42
44	43
45	44
46	45
47	46
48	47
49	48
50	49
51	50
52	51
53	52
54	53
55	54
56	55
57	56
58	57
59	58
60	59
61	60
62	61
63	62
64	63
65	64
66	65
67	66
68	67
69	68
70	69
71	70
72	71
73	72
74	73
75	74
76	75
77	76
78	77
79	78
80	79
81	80
82	81
83	82
84	83
85	84
86	85
87	86
88	87
89	88
90	89
91	90
92	91
93	92
94	93
95	94
96	95
97	96
98	97
99	98
100	99
101	100
102	101
103	102
104	103
105	104
106	105
107	106
108	107
109	108
110	109
111	110
112	111
113	112
114	113
115	114
116	115
117	116
118	117
119	118
120	119
121	120
122	121
123	122
124	123
125	124
126	125
127	126
128	127
129	128
130	129
131	130
132	131
133	132
134	133
135	134
136	135
137	136
138	137
139	138
140	139
141	140
142	141
143	142
144	143
145	144
146	145
147	146
148	147
149	148
150	149
151	150
152	151
153	152
154	153
155	154
156	155
157	156
158	157
159	158
160	159
161	160
162	161
163	162
164	163
165	164
166	165
167	166
168	167
169	168
170	169
171	170
172	171
173	172
174	173
175	174
176	175
177	176
178	177
179	178
180	179
181	180
182	181
183	182
184	183
185	184
186	185
187	186
188	187
189	188
190	189
191	190
192	191
193	192
194	193
195	194
196	195
197	196
198	197
199	198
200	199

LELAND CORPORATION	
CINEMAT SYSTEM	
TITLE	
SIZE	REU
B	A
CODE	NUMBER
81-12170-12	
DATE	SHEET
9-25-85	17 OF 18

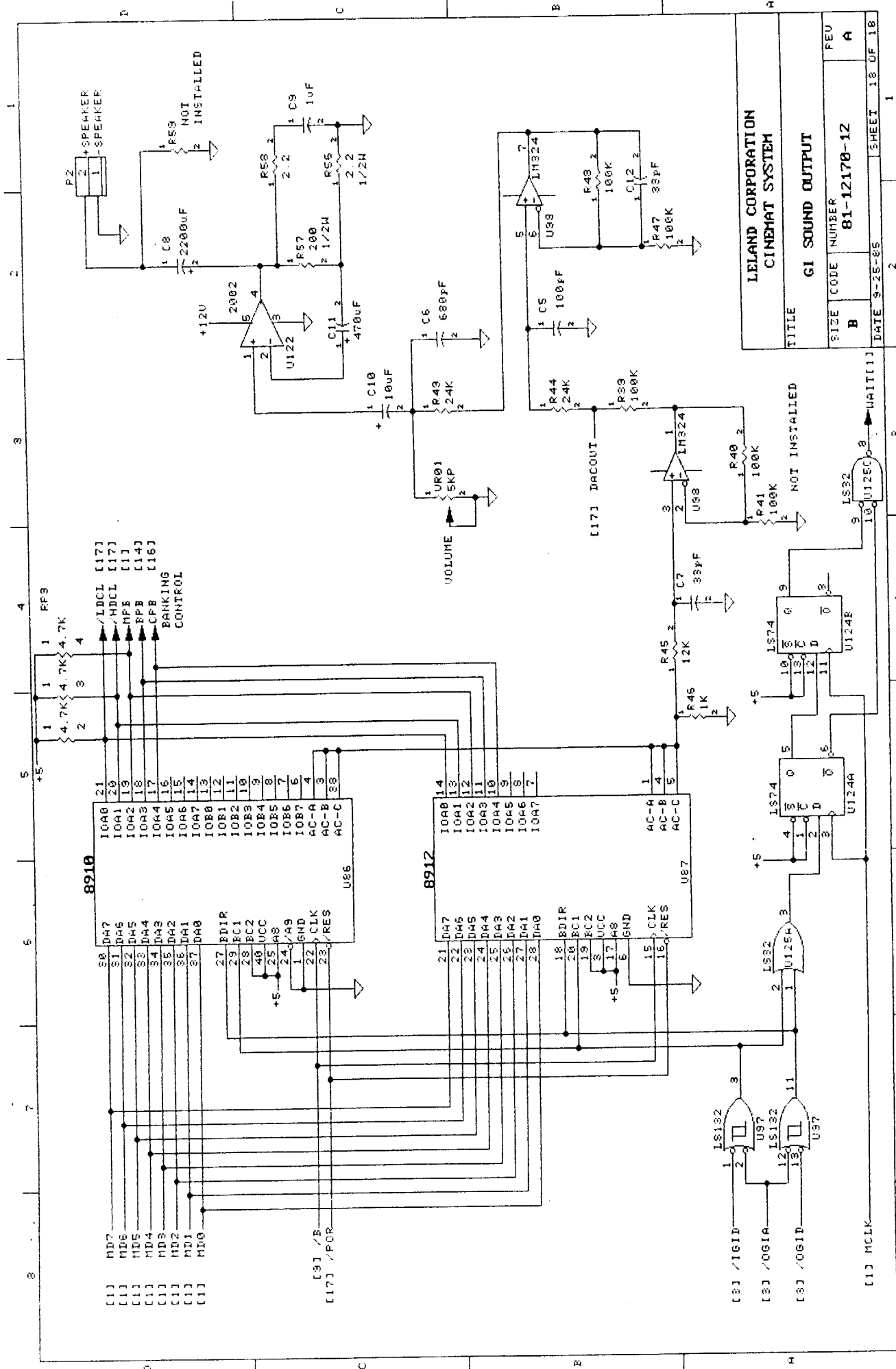

LELAND CORPORATION CINEMAT SYSTEM	
TITLE	
SIZE	FEU
NUMBER	A
81-12170-12	
DATE 9-25-85	SHEET 18 OF 18

ACTION CABINET WIRING DIAGRAM

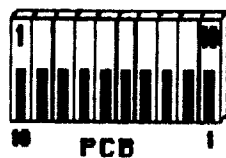
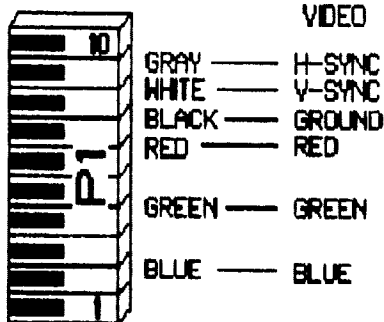
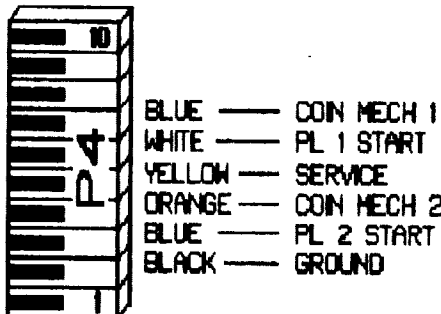
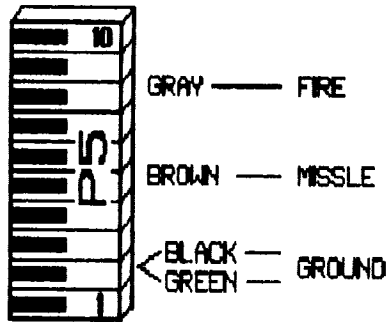
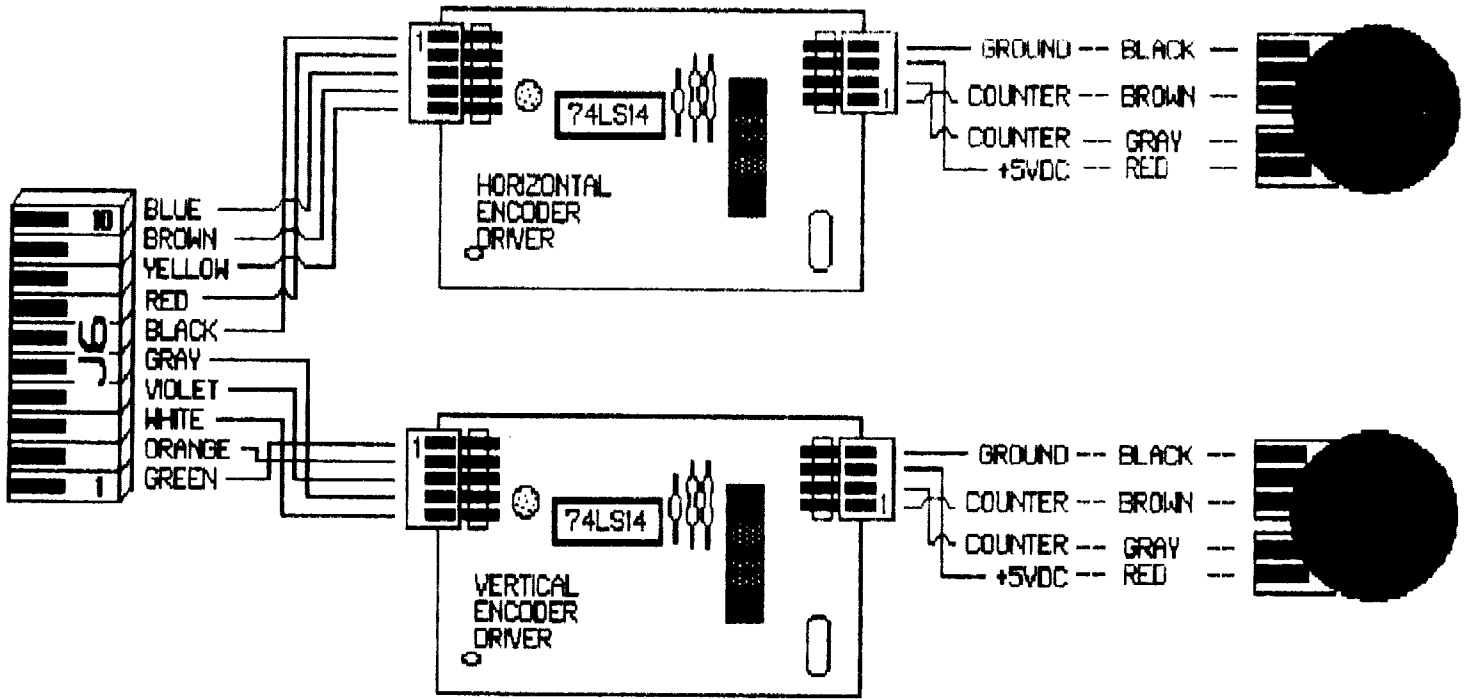

POWER

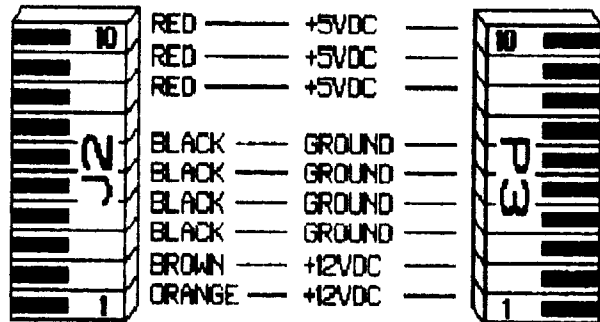
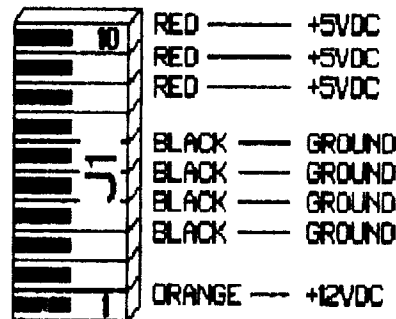

NOTE:

PCB PIN NUMBERS ARE OPPOSITE TO THE PIN NUMBERS MOLDED ON HARNESS CONNECTORS



1841 Friendship Dr., El Cajon, CA 92020-9981
619-562-7000 Telex - 4974293 Cintron Fax - 619-562-9468

LELAND PART # 72-11700-01

THE LELAND CORP. 1988 ALL RIGHTS RESERVED