

SEGA

MADE IN JAPAN

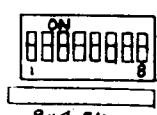

8x510Ω

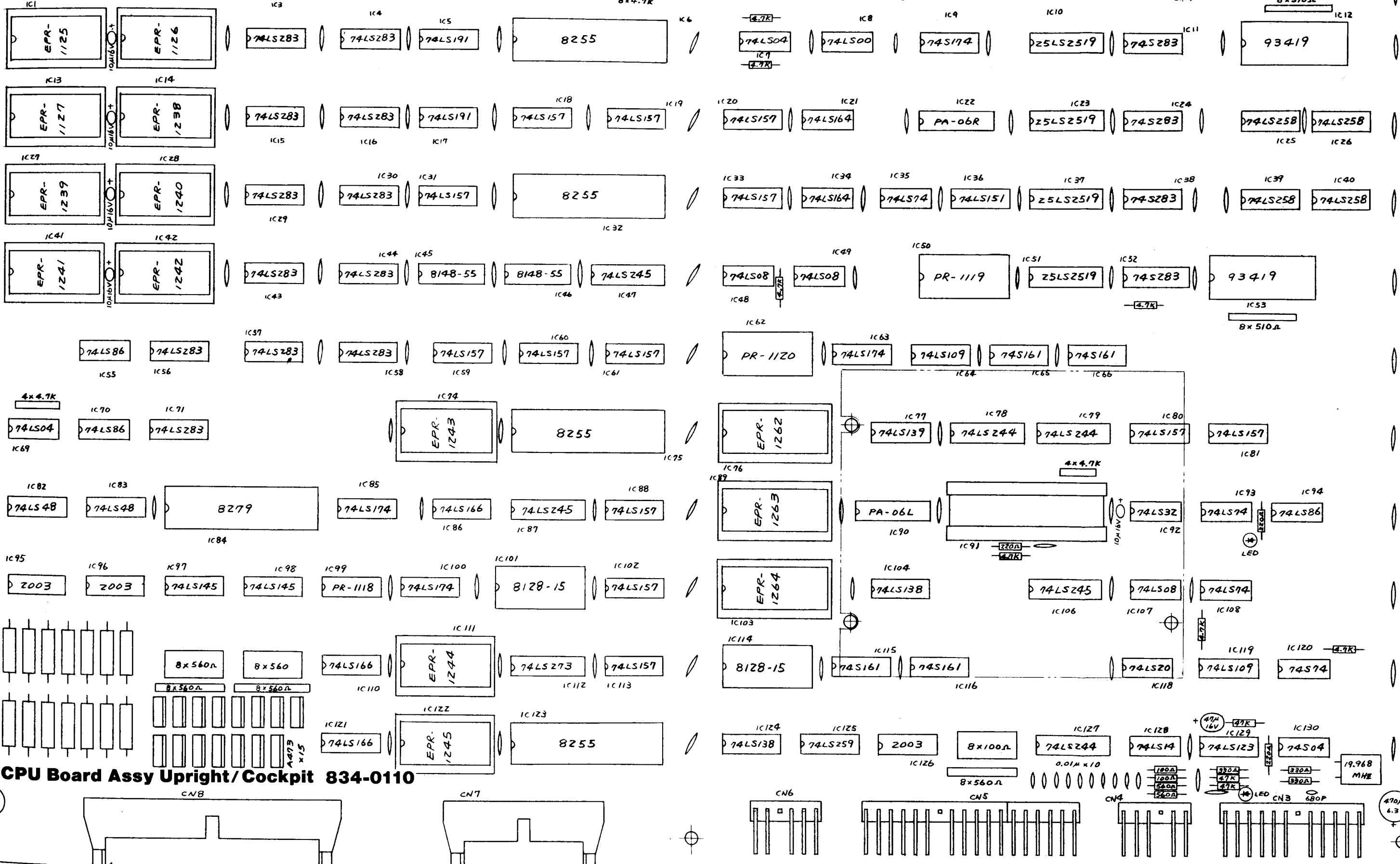

CPU Board Assy Upright/Cockpit 834-0110

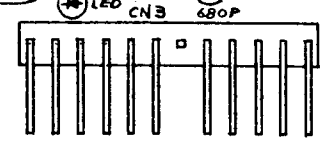
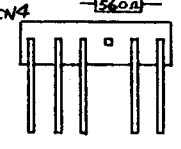
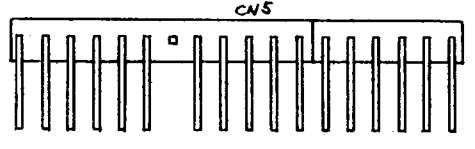
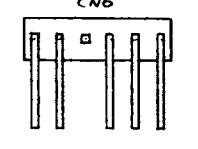
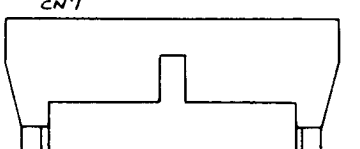
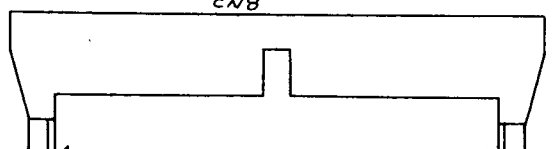





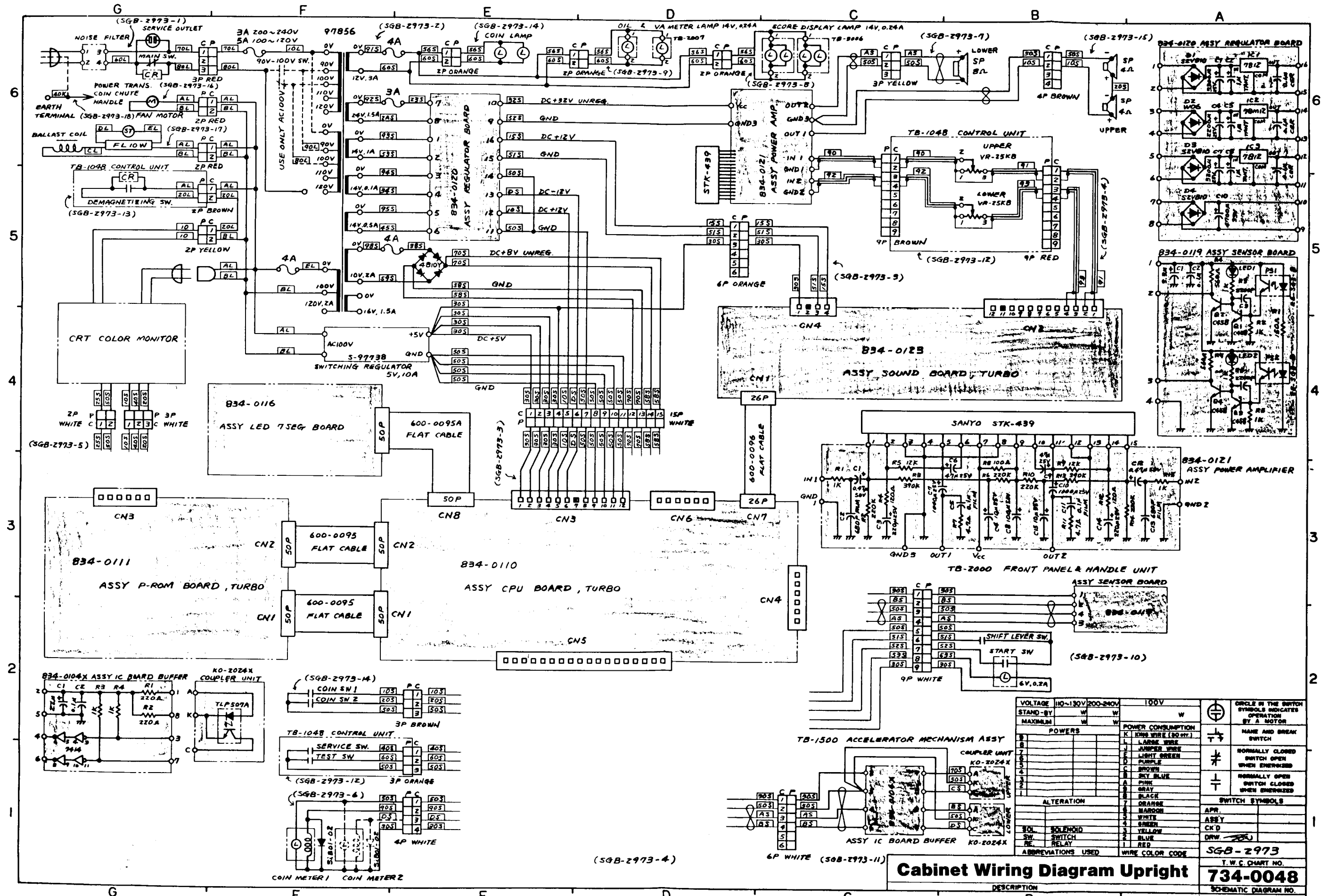

**Cabinet Wiring Diagram Upright**  
 T.W.C. CHART NO. **734-0048**  
 SCHEMATIC DIAGRAM NO.

VOLTAGE		110-130V 200-240V		100V		CIRCLE IN THE SWITCH SYMBOLS INDICATES OPERATION BY A MOTOR
STAND-BY	W	W	W	W	W	
MAXIMUM	W	W	W	W	W	NAME AND BREAK SWITCH
POWERS						
1						NORMALLY OPEN SWITCH CLOSED WHEN ENERGIZED
2						
3						SWITCH SYMBOLS
4						
5						APR.
6						
7						ASSY
8						
9						CK'D
10						
11						DRW.
12						
13						SGB-2973
14						
15						T.W.C. CHART NO.
16						
17						734-0048
18						
19						SCHEMATIC DIAGRAM NO.
20						

**Regulator Board  
834-0120**

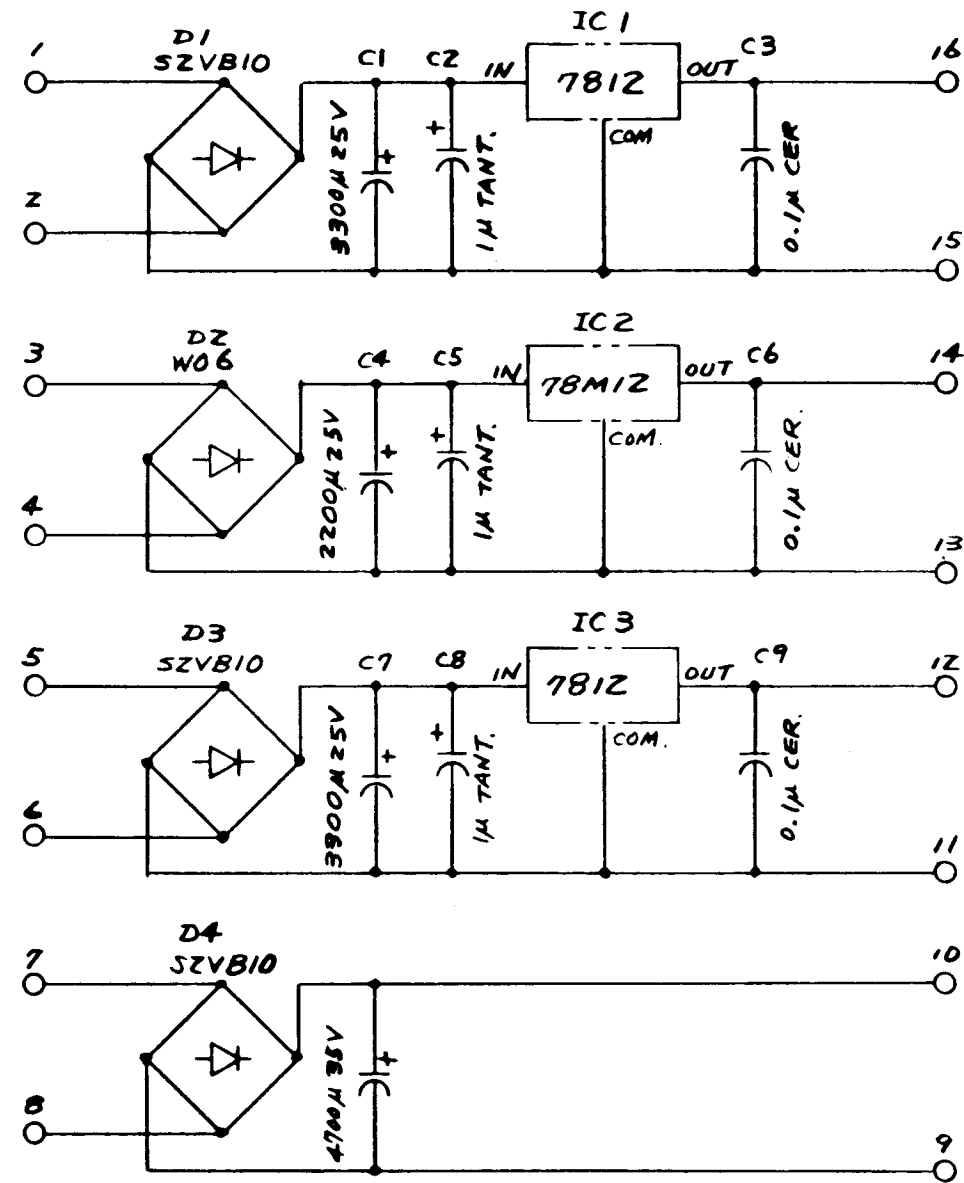

**LED 7-Segment Board  
834-0119**

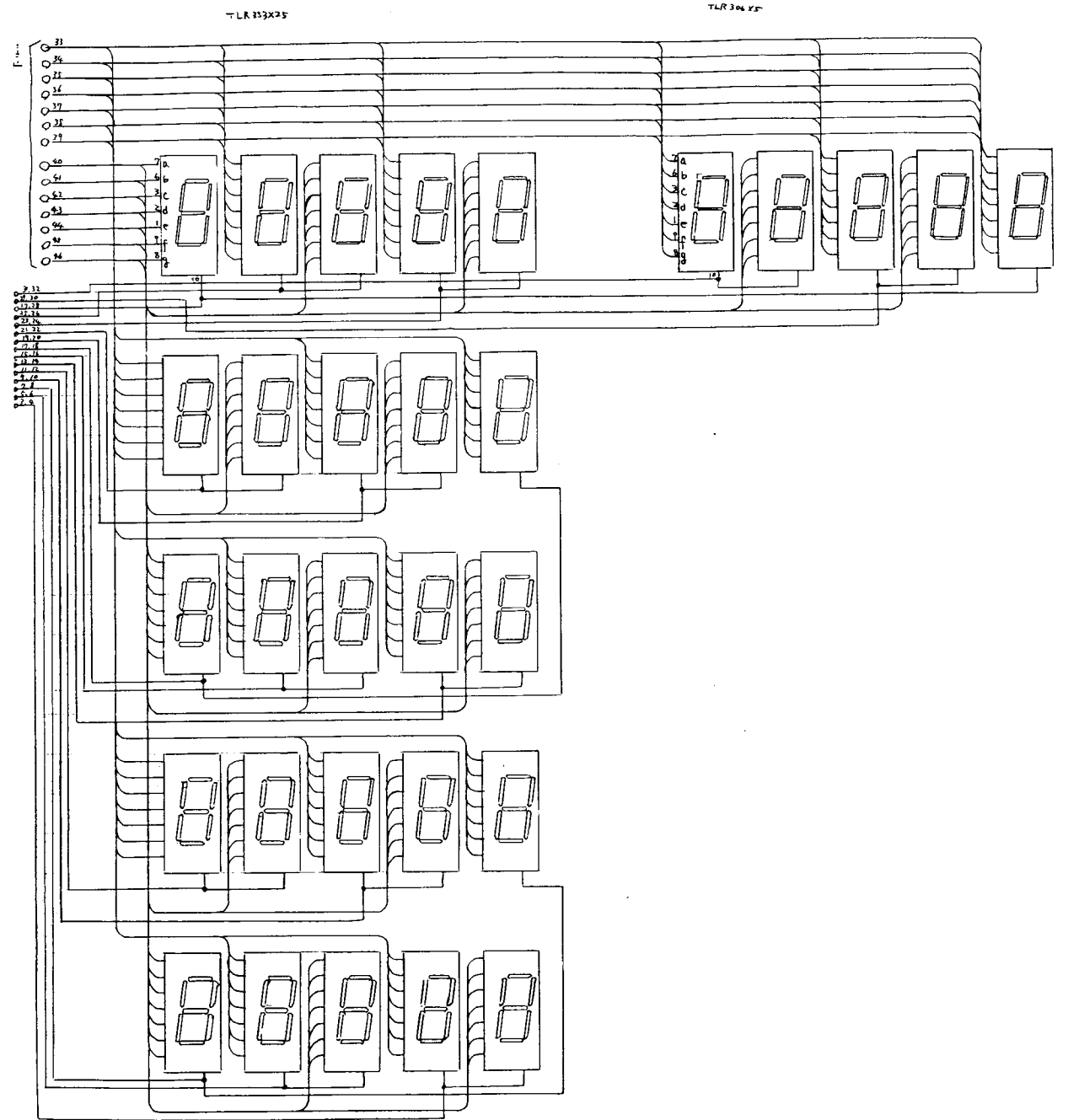

**Sound Board  
834-0123**

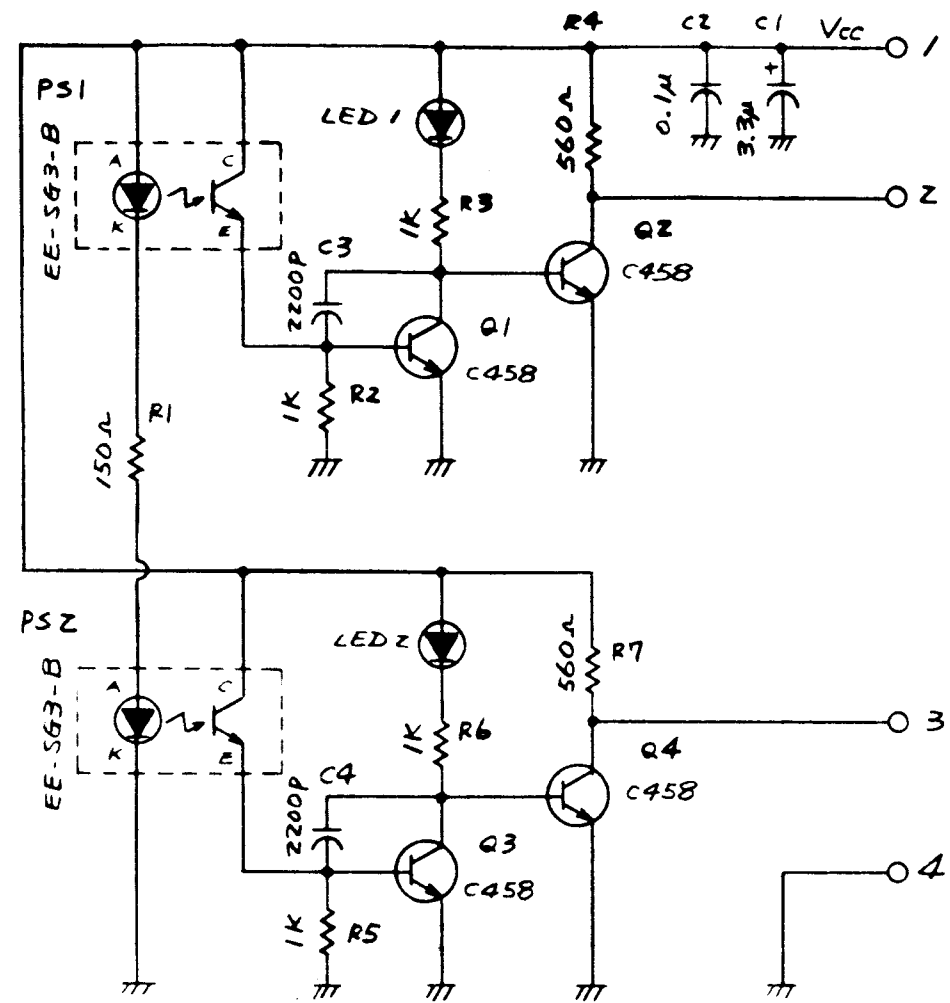

CN1  
TO MAIN BOARD

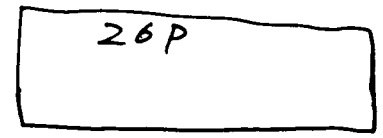
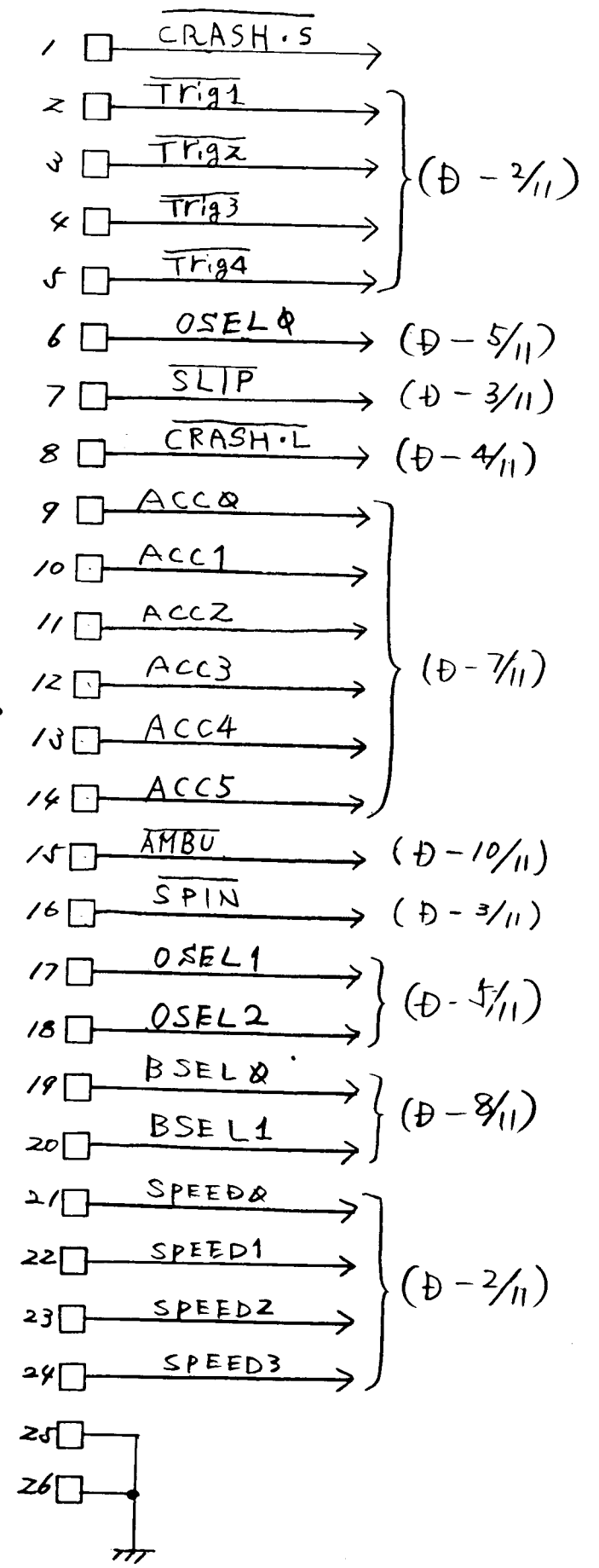

**Tacho Meter Board  
834-0117**

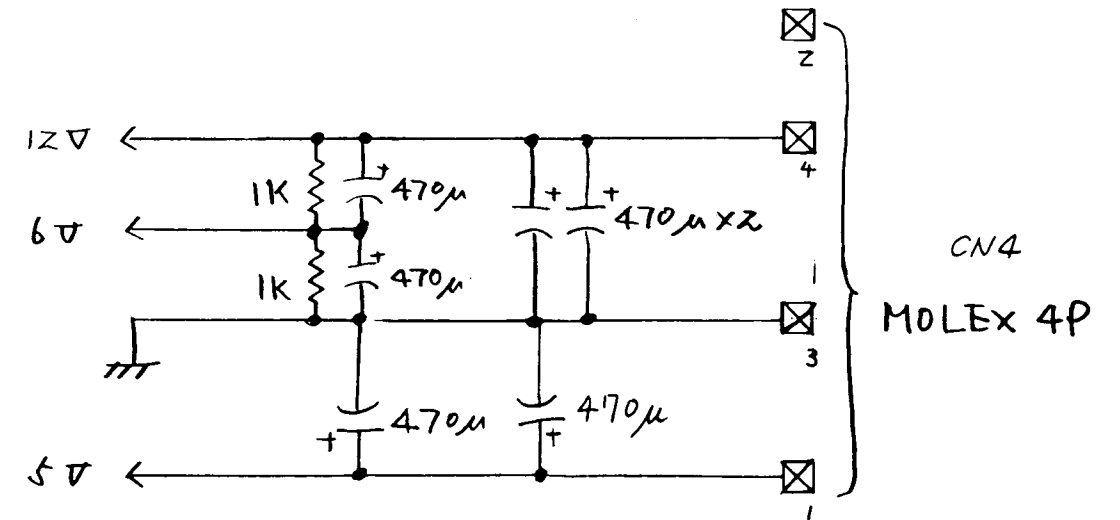
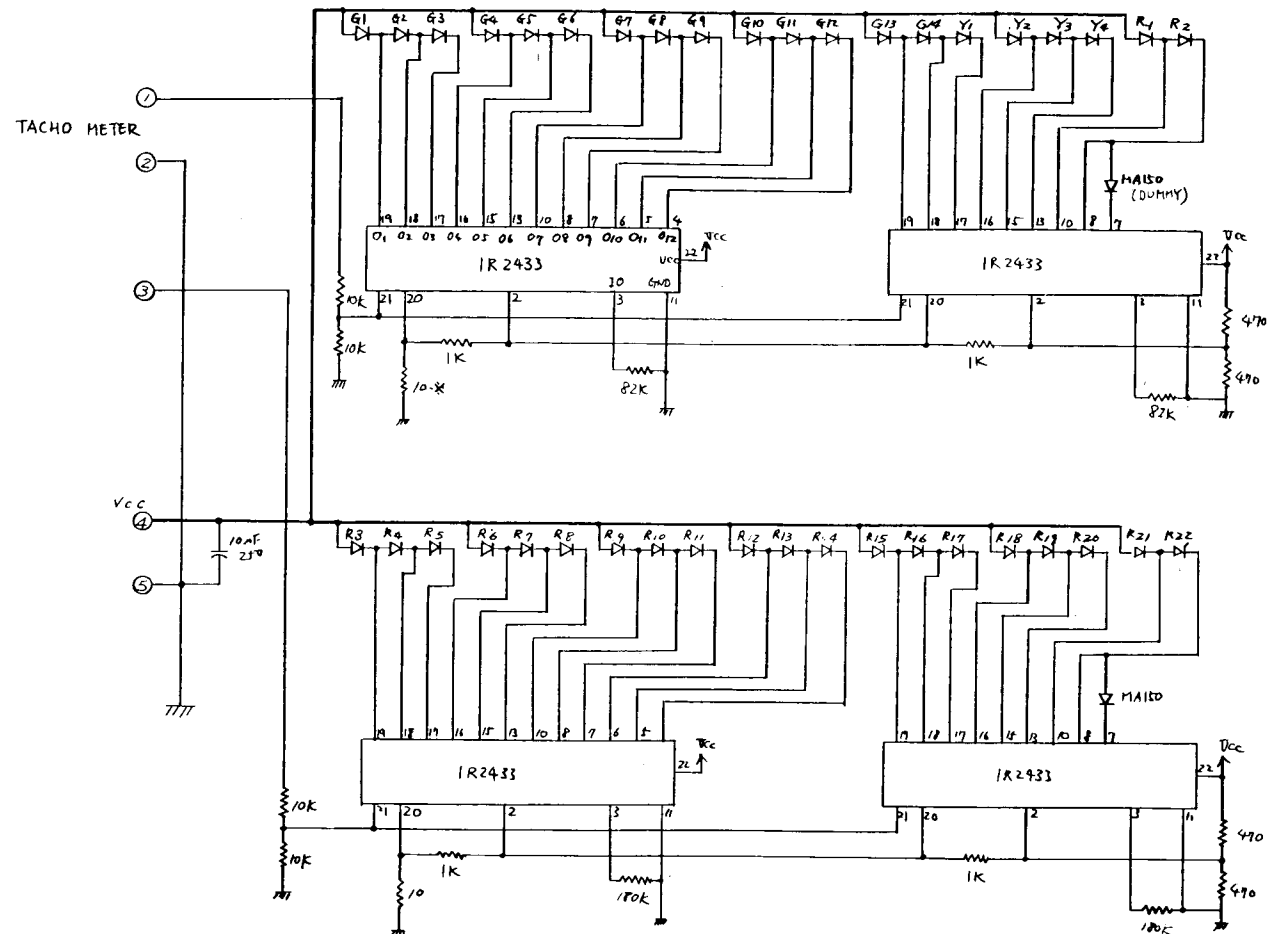

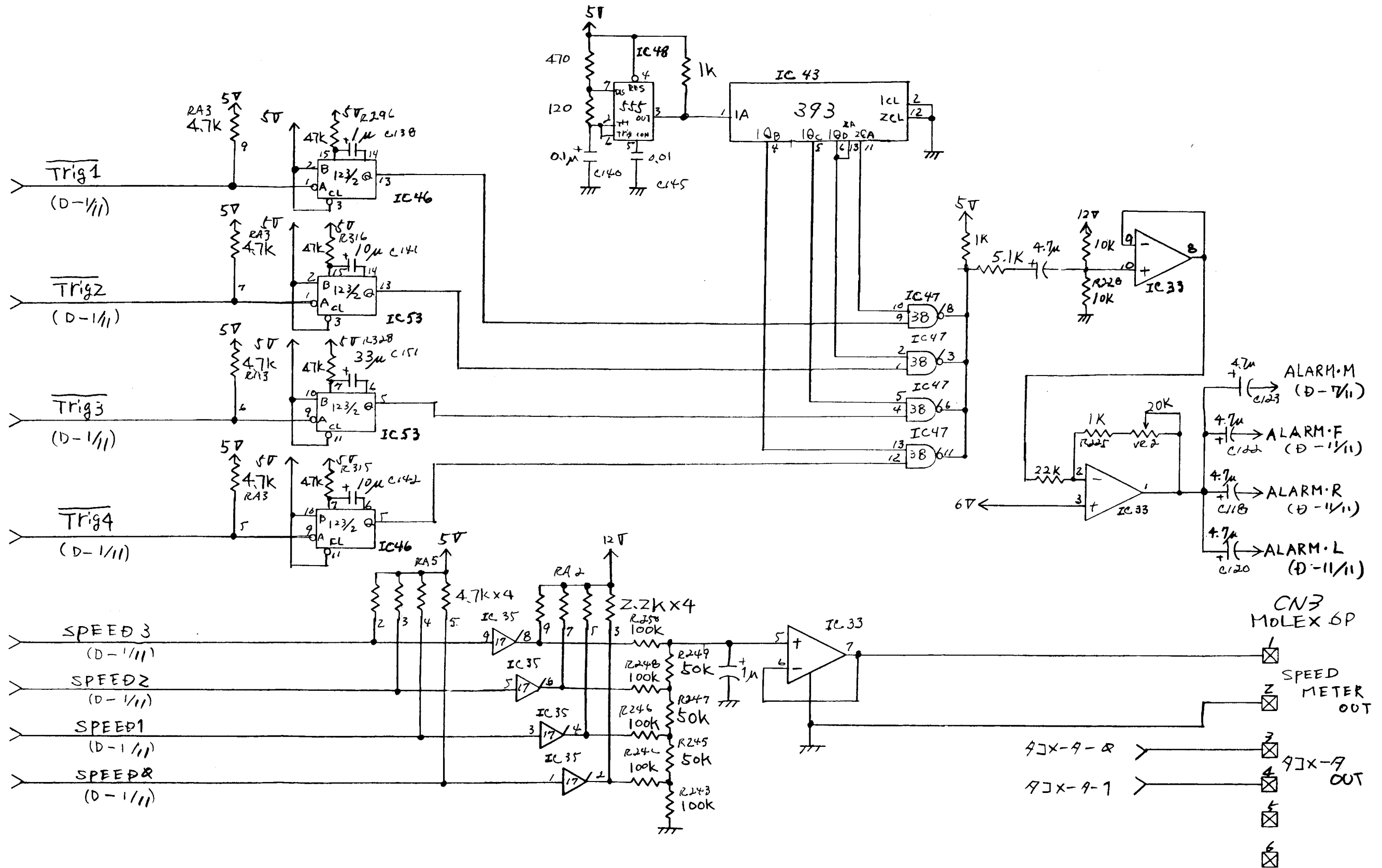

**Sound Board**  
**834-0123**  
**Turbo Sound Alarm D-2/11 126**



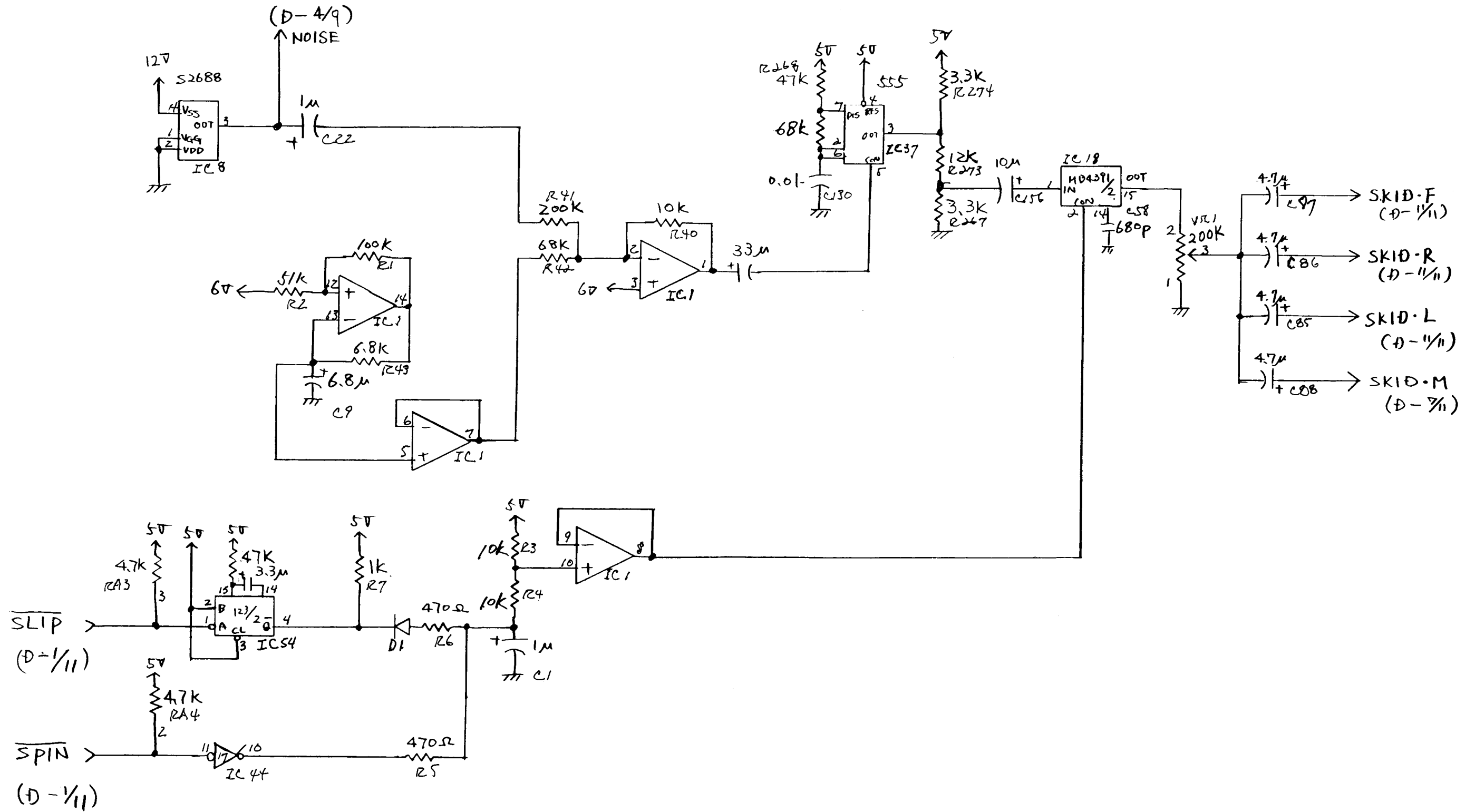

Sound Board  
834-0123

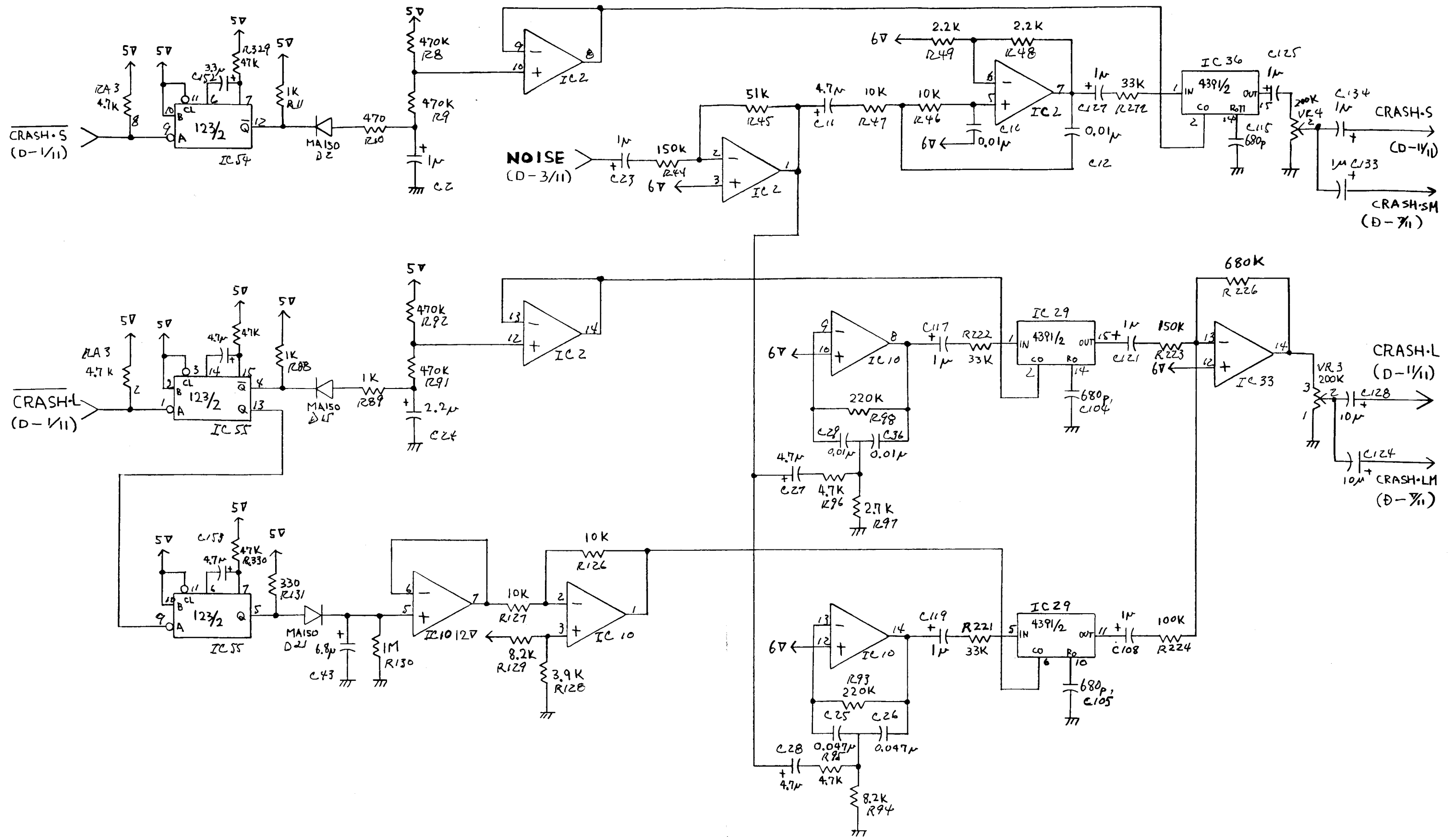

**Sound Board  
834-0123**



OTHER CAR OSC

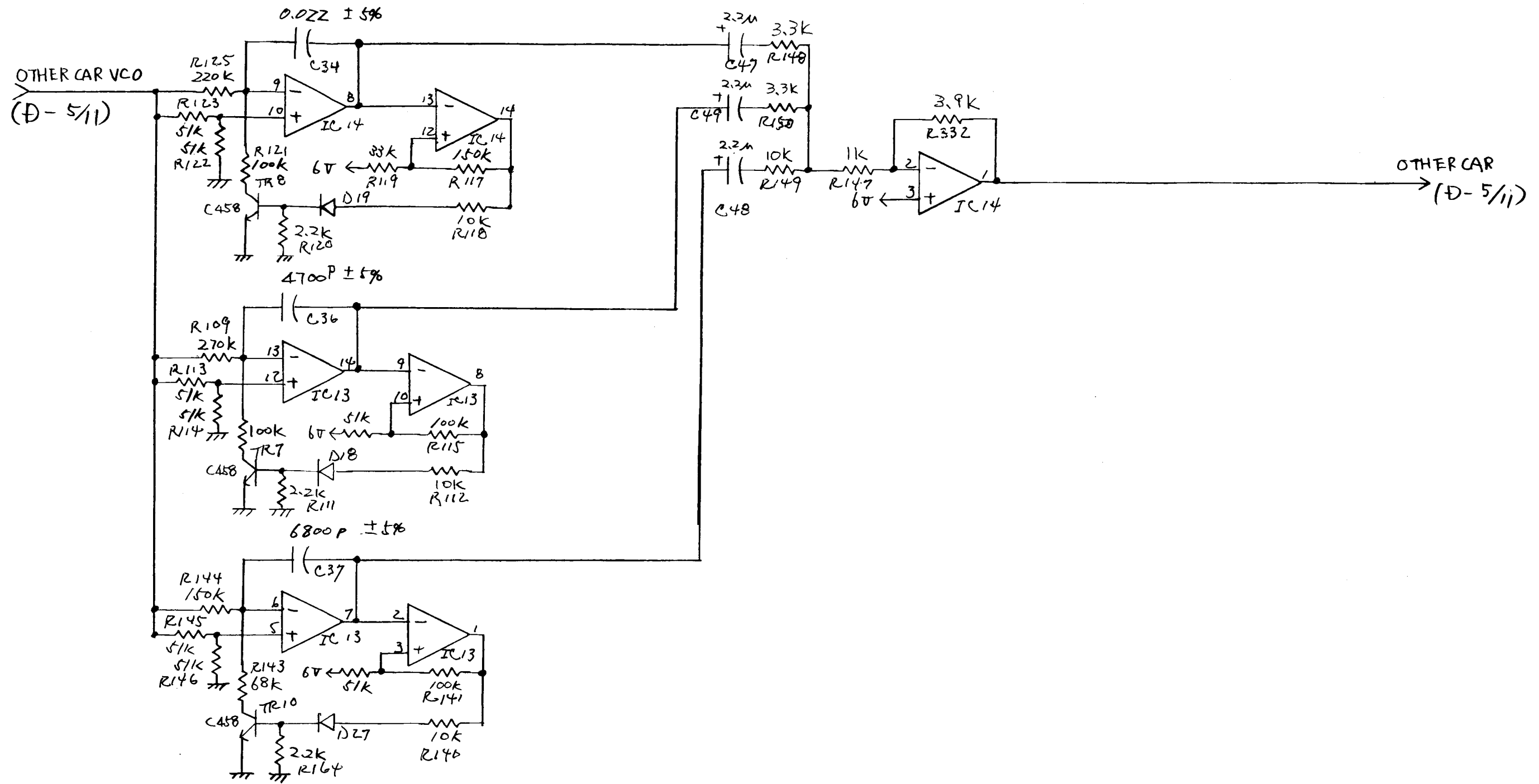

Sound Board  
834-0123

R: 100K x 12

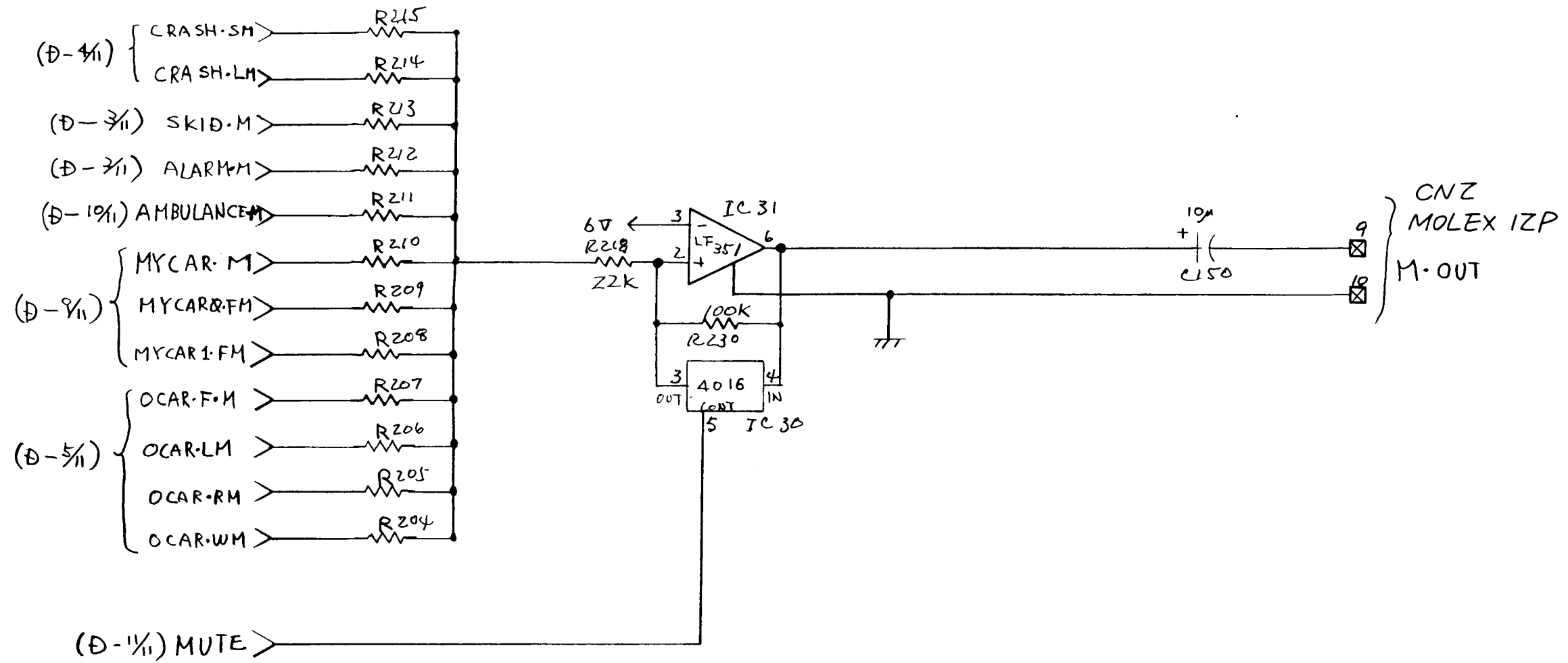

Sound Board  
834-0123

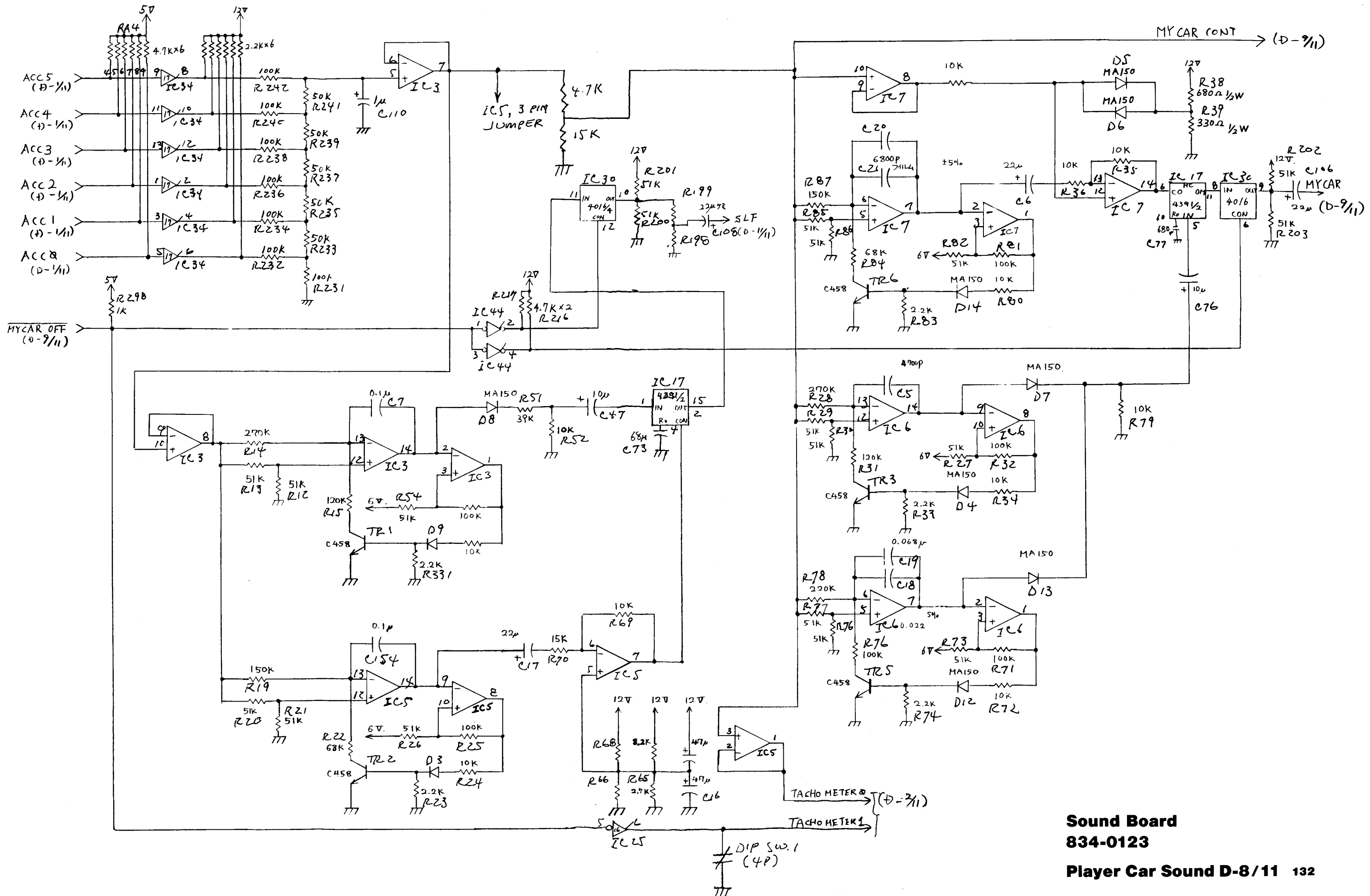

**Sound Board**  
**834-0123**  
**Player Car Sound D-8/11 132**







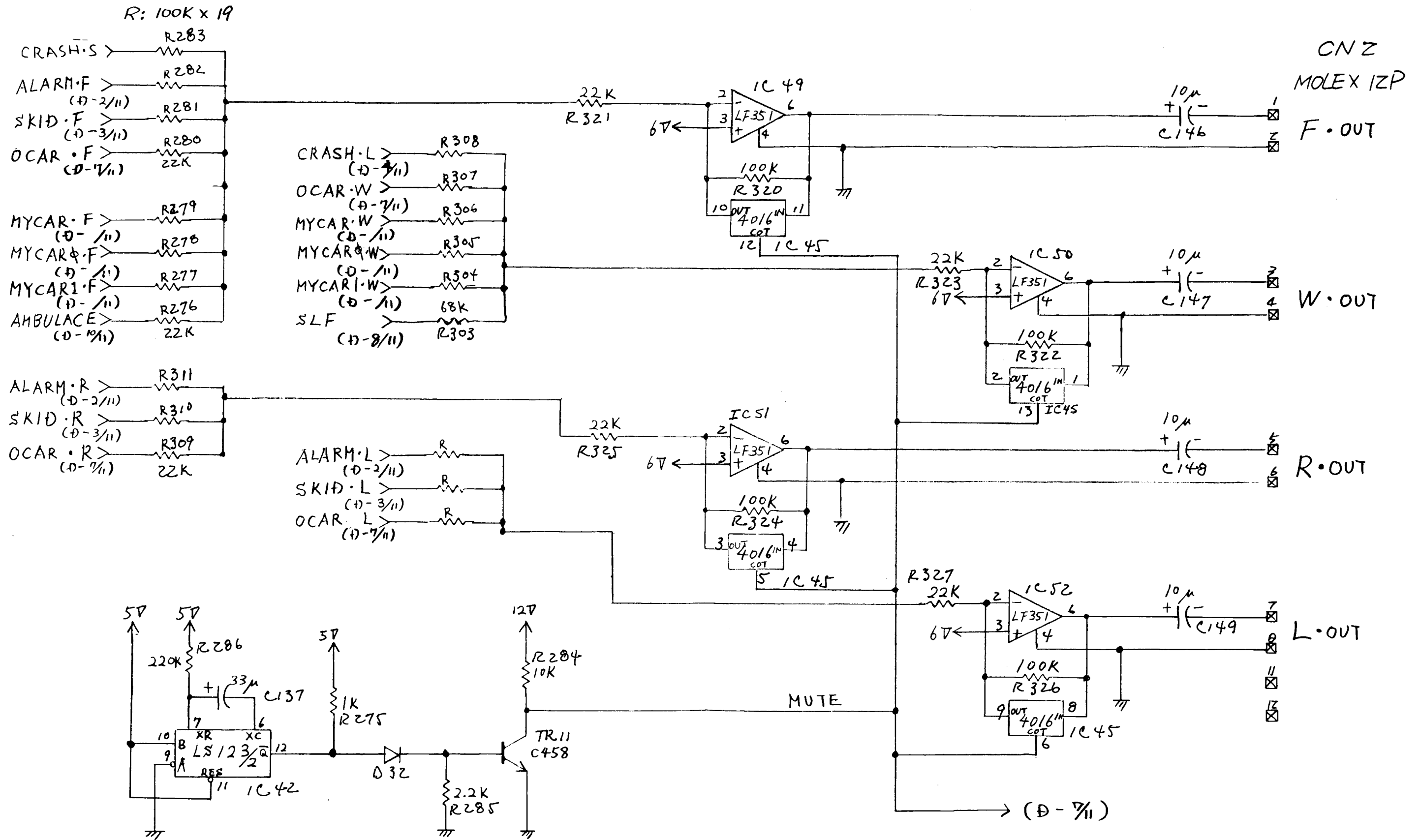

Sound Board  
834-0123

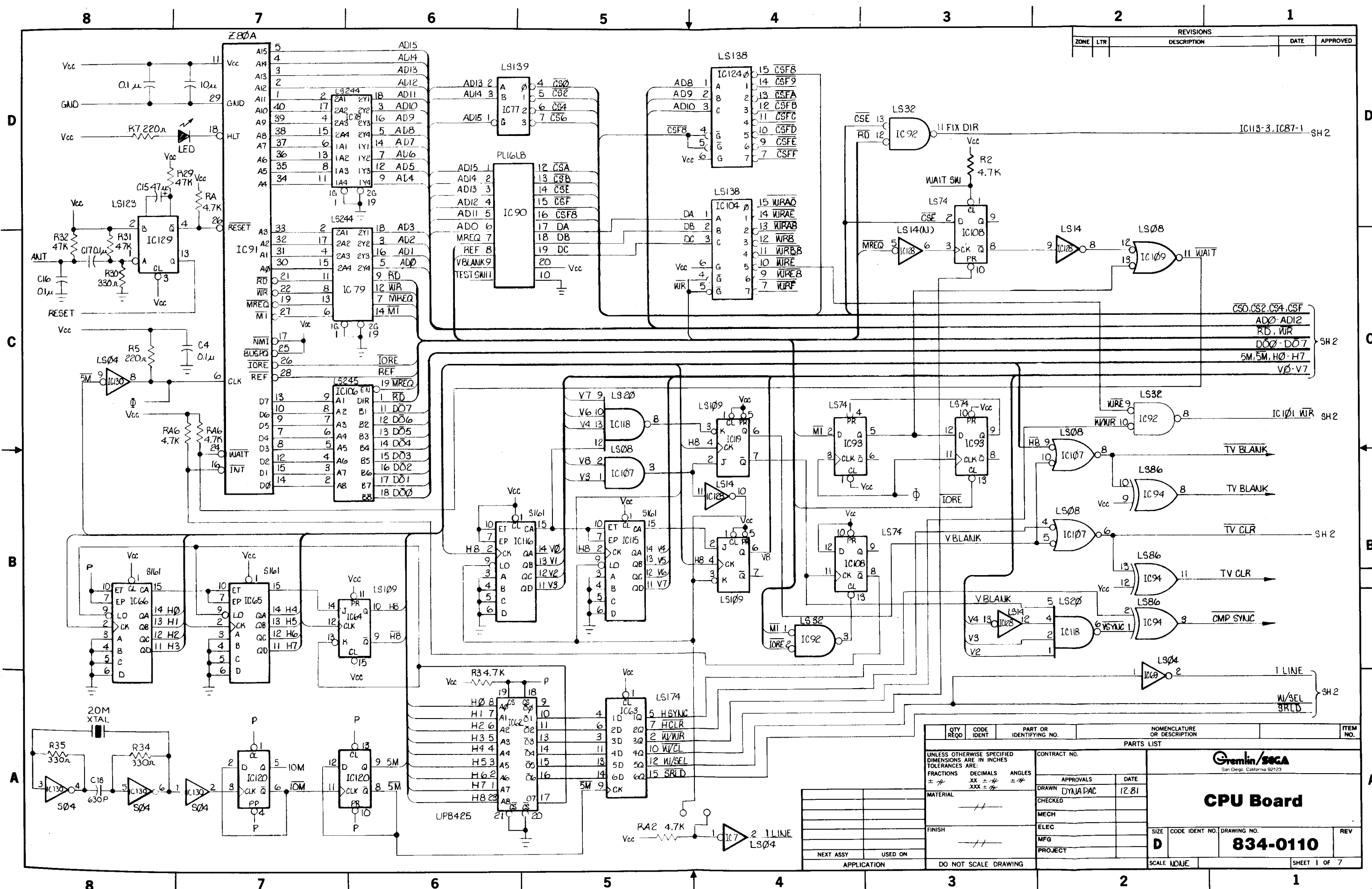

REVISIONS				
ZONE	LTR	DESCRIPTION	DATE	APPROVED

QTY REQD	CODE IDENT	PART OR IDENTIFYING NO.	NOMENCLATURE OR DESCRIPTION	ITEM NO.

PARTS LIST	
UNLESS OTHERWISE SPECIFIED DIMENSIONS ARE IN INCHES TOLERANCES ARE:	CONTRACT NO.
FRACTIONS DECIMALS ANGLES	APPROVALS DATE
± 1/16 ± .005 ± 1/2	DRAWN DYNA PAC 12.81
	CHECKED
	MECH
	ELEC
	MFG
	PROJECT

MATERIAL		FINISH	

NEXT ASSY USED ON		APPLICATION	

DO NOT SCALE DRAWING	
----------------------	--

SCALE	CODE IDENT NO. DRAWING NO.	REV

PARTS LIST		CONTRACT NO.	
UNLESS OTHERWISE SPECIFIED DIMENSIONS ARE IN INCHES TOLERANCES ARE:		APPROVALS DATE	
FRACTIONS DECIMALS ANGLES		DRAWN DYNA PAC 12.81	
± 1/16 ± .005 ± 1/2		CHECKED	
		MECH	
		ELEC	
		MFG	
		PROJECT	

  

CPU Board	
Gremlin/SGCA	
San Diego, California 92123	
SIZE	CODE IDENT NO. DRAWING NO.
D	834-0110
SCALE	1/4" = 1"
SHEET	1 OF 7

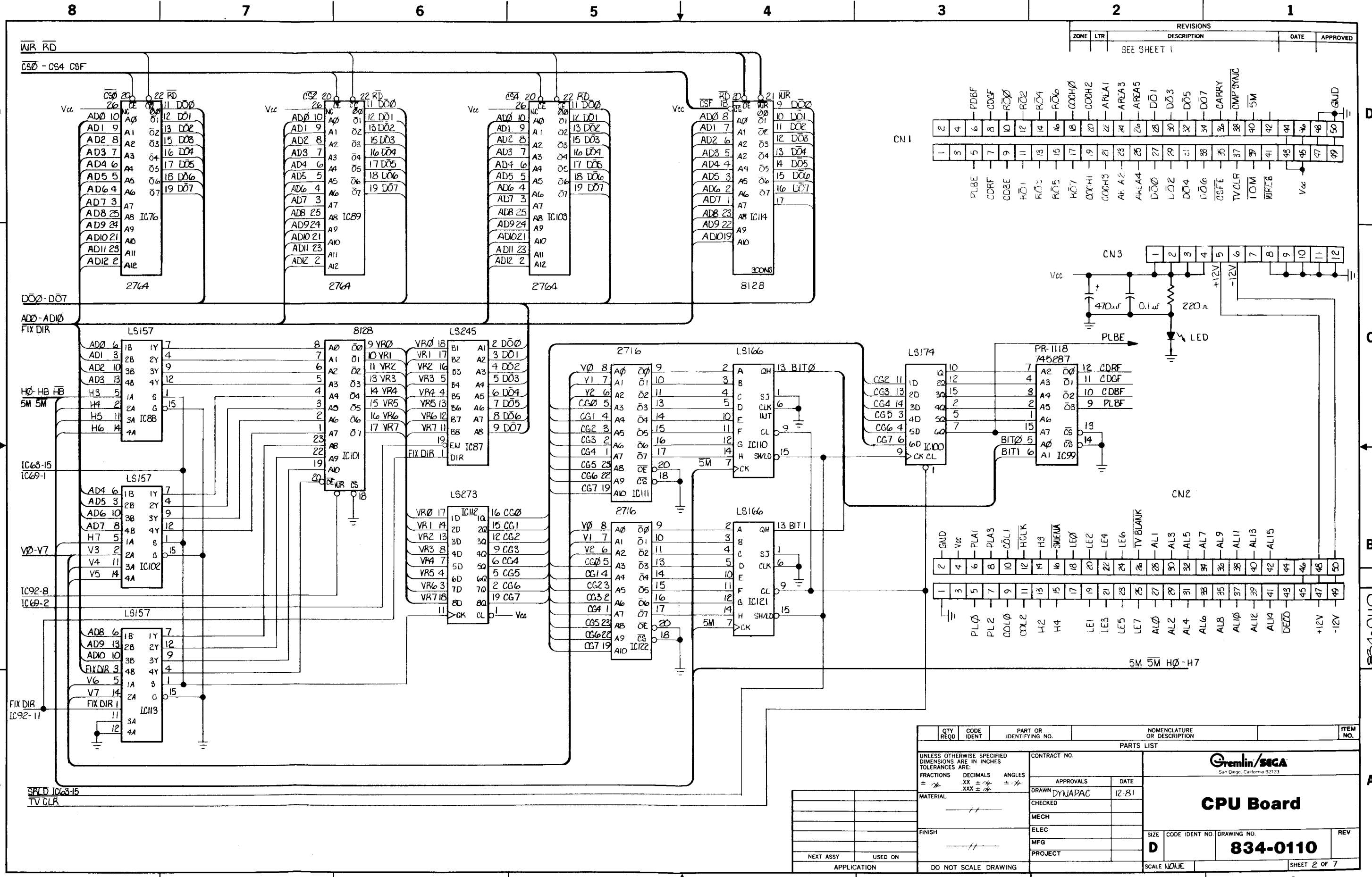

REVISIONS				DATE	APPROVED
ZONE	LTR	DESCRIPTION			
		SEE SHEET 1			

ZONE	LTR	DESCRIPTION	DATE	APPROVED
		SEE SHEET 1		

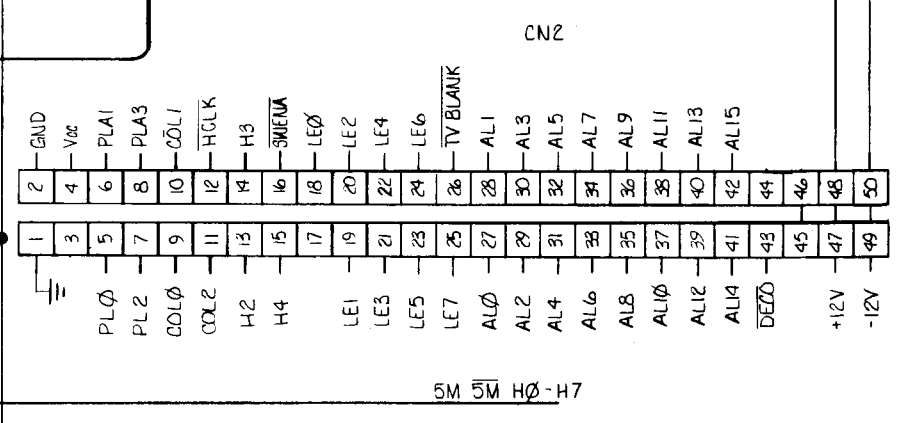
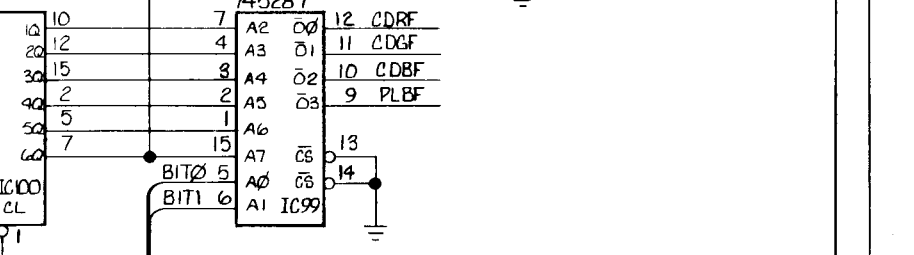
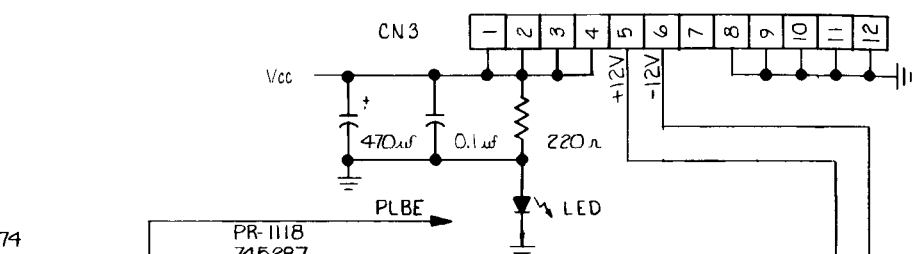

QTY REQD	CODE IDENT	PART OR IDENTIFYING NO.	NOMENCLATURE OR DESCRIPTION	ITEM NO.

UNLESS OTHERWISE SPECIFIED DIMENSIONS ARE IN INCHES TOLERANCES ARE:		CONTRACT NO.	
FRACTIONS	DECIMALS	ANGLES	
± .010	± .005	± .005	
MATERIAL		DRAWN DYNAPAC	
FINISH		CHECKED	
NEXT ASSY		MECH	
USED ON		ELEC	
APPLICATION		MFG	
DO NOT SCALE DRAWING		PROJECT	

APPROVALS		DATE
DRAWN DYNAPAC		12-81
<b>CPU Board</b>		
SIZE	CODE IDENT NO.	DRAWING NO.
D		<b>834-0110</b>
SCALE NONE		SHEET 2 OF 7

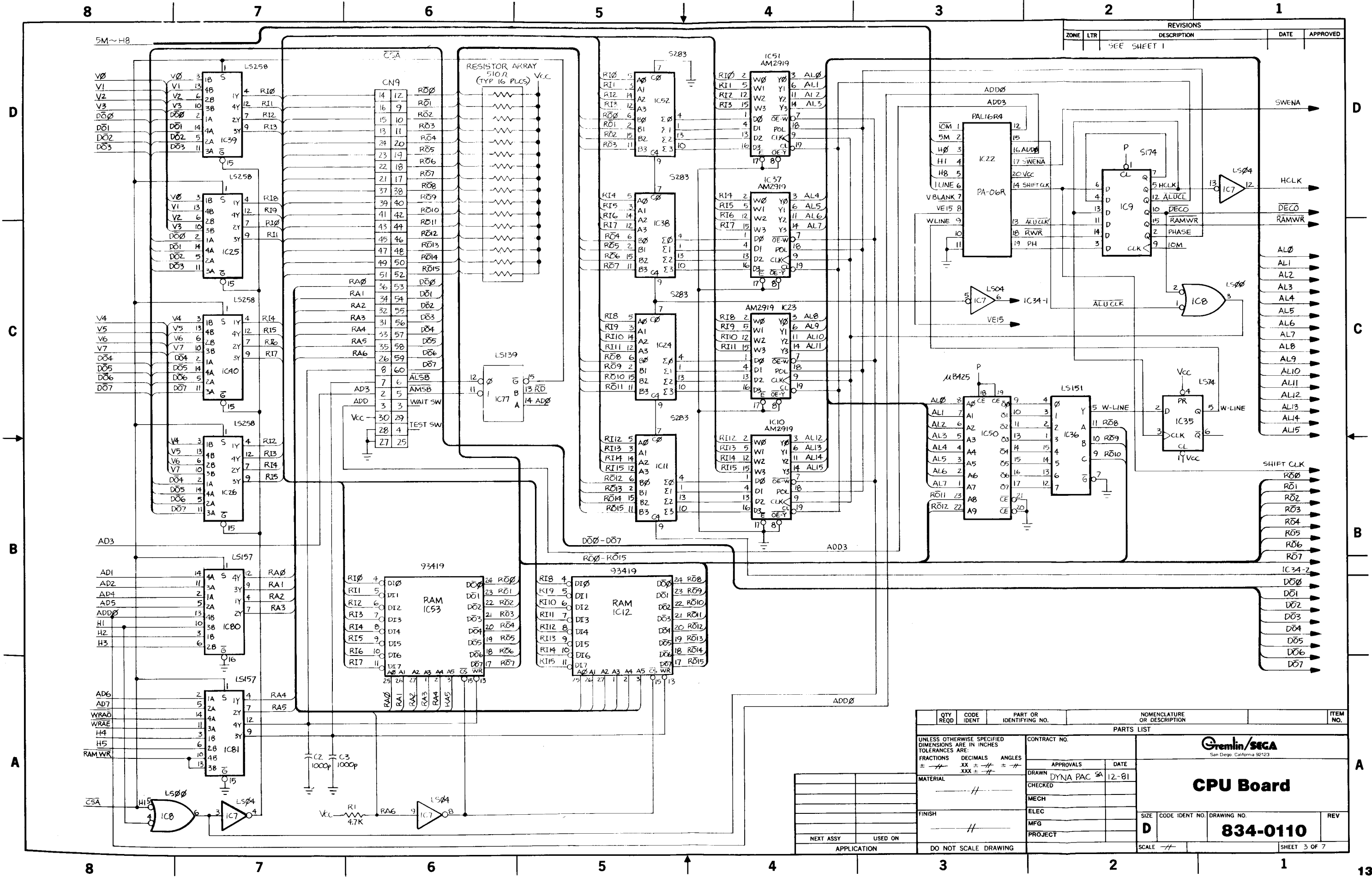

REVISIONS			
ZONE	LTR	DESCRIPTION	DATE
		SEE SHEET 1	

QTY REQD	CODE IDENT	PART OR IDENTIFYING NO.	NOMENCLATURE OR DESCRIPTION	ITEM NO.
PARTS LIST				
UNLESS OTHERWISE SPECIFIED DIMENSIONS ARE IN INCHES TOLERANCES ARE:		CONTRACT NO.		
FRACTIONS	DECIMALS	ANGLES	APPROVALS	DATE
± .XX ± .#	± .#	± #°	DRAWN	12-81
MATERIAL		MECH		
FINISH		ELEC		
NEXT ASSY		MFG		
USED ON		PROJECT		
APPLICATION		DO NOT SCALE DRAWING		

**Gremlin/SEGA**  
San Diego, California 92123

# CPU Board

SIZE **D** CODE IDENT NO. **834-0110** REV

SCALE **1/8"** SHEET 3 OF 7

REVISIONS			
ZONE	LTR	DESCRIPTION	DATE
		SEE SHEET 1	

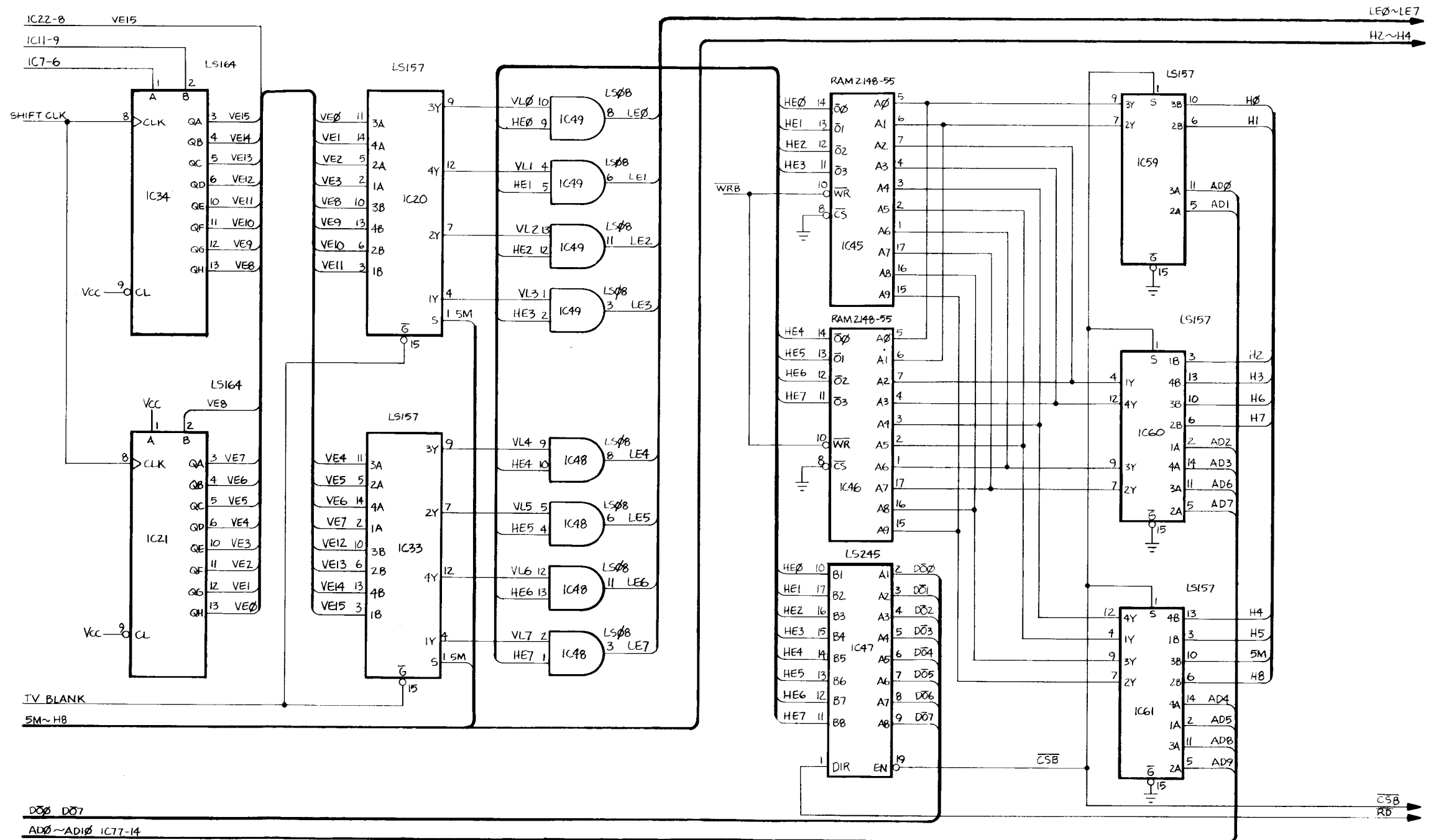

D00 D07  
AD0~AD10 IC77-14

QTY REQD	CODE IDENT	PART OR IDENTIFYING NO.	NOMENCLATURE OR DESCRIPTION	ITEM NO.
PARTS LIST				
UNLESS OTHERWISE SPECIFIED DIMENSIONS ARE IN INCHES TOLERANCES ARE:		CONTRACT NO.		
FRACTIONS ±	DECIMALS .XX ±	ANGLES ° ±	APPROVALS	
±	±	±	DATE	
MATERIAL		DRAWN DYNAPAC SA 12-81		
FINISH		CHECKED		
NEXT ASSY		MECH		
USED ON		ELEC		
APPLICATION		MFG		
DO NOT SCALE DRAWING		PROJECT		
		SIZE CODE IDENT NO. DRAWING NO.		REV
		D 834-0110		
		SCALE --/--		SHEET 4 OF 7



### CPU Board

834-0110

834-0110

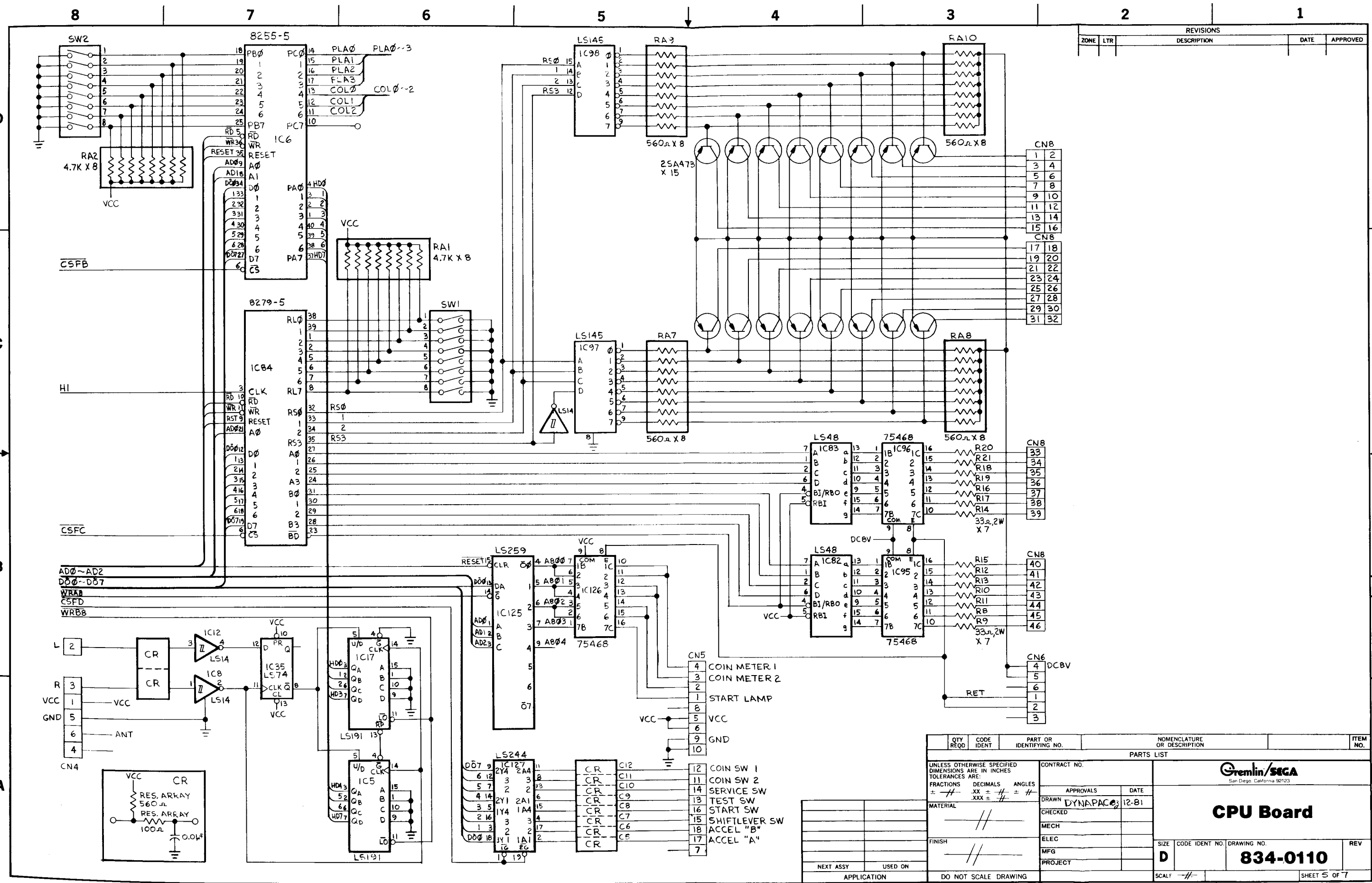

REVISIONS				
ZONE	LTR	DESCRIPTION	DATE	APPROVED

CN8	
1	2
3	4
5	6
7	8
9	10
11	12
13	14
15	16
CN8	
17	18
19	20
21	22
23	24
25	26
27	28
29	30
31	32

CN8	
33	34
35	36
37	38
39	39

CN8	
40	41
42	43
44	45
46	46

CN6	
4	DCBV
5	
6	
1	
2	
3	

QTY REQD	CODE IDENT	PART OR IDENTIFYING NO.	NOMENCLATURE OR DESCRIPTION	ITEM NO.
PARTS LIST				
UNLESS OTHERWISE SPECIFIED DIMENSIONS ARE IN INCHES TOLERANCES ARE:		CONTRACT NO.		
FRACTIONS	DECIMALS	ANGLES	APPROVALS	DATE
± #/16	± .XX	± #°	DYNAPAC	12-81
MATERIAL		FINISH		
NEXT ASSY		USED ON		APPLICATION
				DO NOT SCALE DRAWING

**Gremlin/SEGA**  
San Diego, California 92123

## CPU Board

SIZE: **D** CODE IDENT NO: **834-0110** REV:

SHEET 5 OF 7

8

7

6

5

4

3

2

1

ZONE		LTR		REVISIONS		DATE	APPROVED
				DESCRIPTION			

D

D

C

C

B

B

A

A

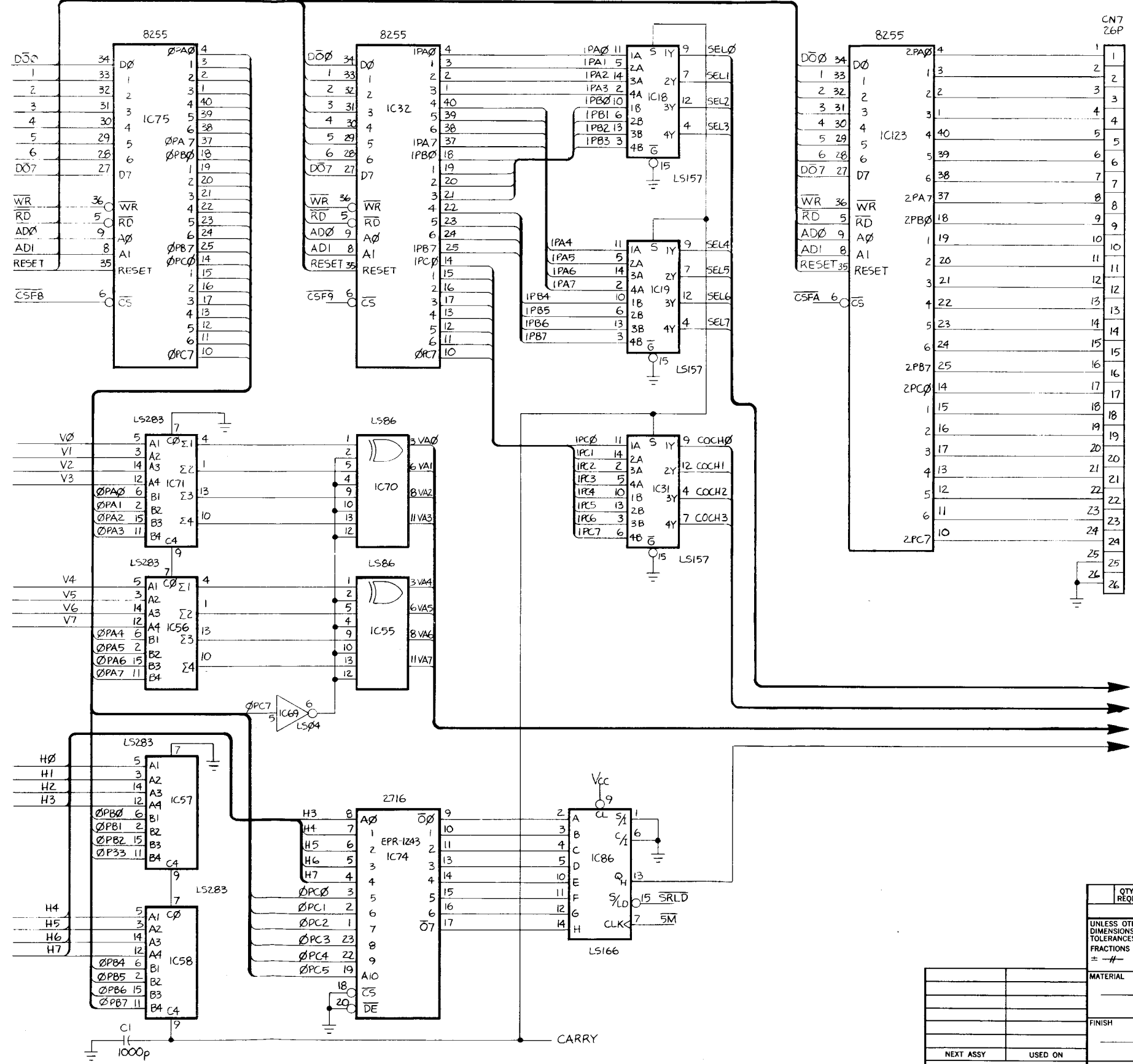

TO SHEET 7  
AREA 5

QTY REQD	CODE IDENT	PART OR IDENTIFYING NO.	NOMENCLATURE OR DESCRIPTION	ITEM NO.
PARTS LIST				
UNLESS OTHERWISE SPECIFIED DIMENSIONS ARE IN INCHES TOLERANCES ARE:				
FRACTIONS		DECIMALS	ANGLES	
± #		.XX ± #	± #	
		.XXX ± #	± #	
MATERIAL		CONTRACT NO.		
FINISH		APPROVALS		
NEXT ASSY		DATE		
USED ON		DRAWN DYNA PAC 12-81		
APPLICATION		MECH		
		ELEC		
		MFG		
		PROJECT		
		SIZE CODE IDENT NO. DRAWING NO. REV		
		D 834-0110		
		SCALE -- SHEET 6 OF 7		

8

7

6

5

4

3

2

1

141

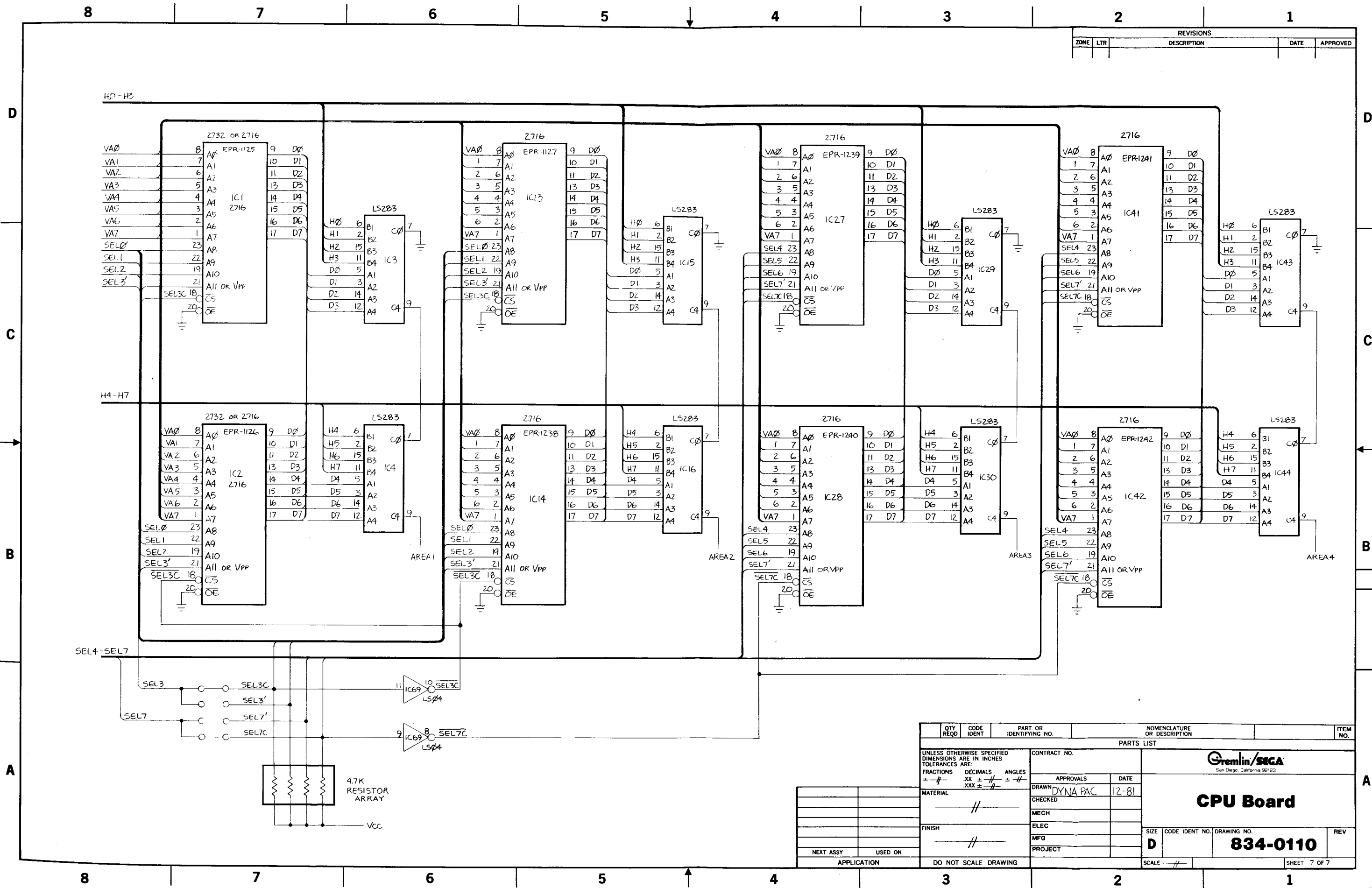

REVISIONS				
ZONE	LTR	DESCRIPTION	DATE	APPROVED

QTY REQD	CODE IDENT	PART OR IDENTIFYING NO.	NOMENCLATURE OR DESCRIPTION	ITEM NO.
PARTS LIST				
UNLESS OTHERWISE SPECIFIED DIMENSIONS ARE IN INCHES TOLERANCES ARE:		CONTRACT NO.		
FRACTIONS ± #	DECIMALS .XX ± #	ANGLES XXX ± #	APPROVALS	DATE
MATERIAL		DRAWN DYNA PAC 12-81		
FINISH		CHECKED		
NEXT ASSY		MECH		
USED ON		ELEC		
APPLICATION		MFG		
DO NOT SCALE DRAWING		PROJECT		
SCALE		SIZE CODE IDENT NO. DRAWING NO. REV		
		D 834-0110		
		SHEET 7 OF 7		



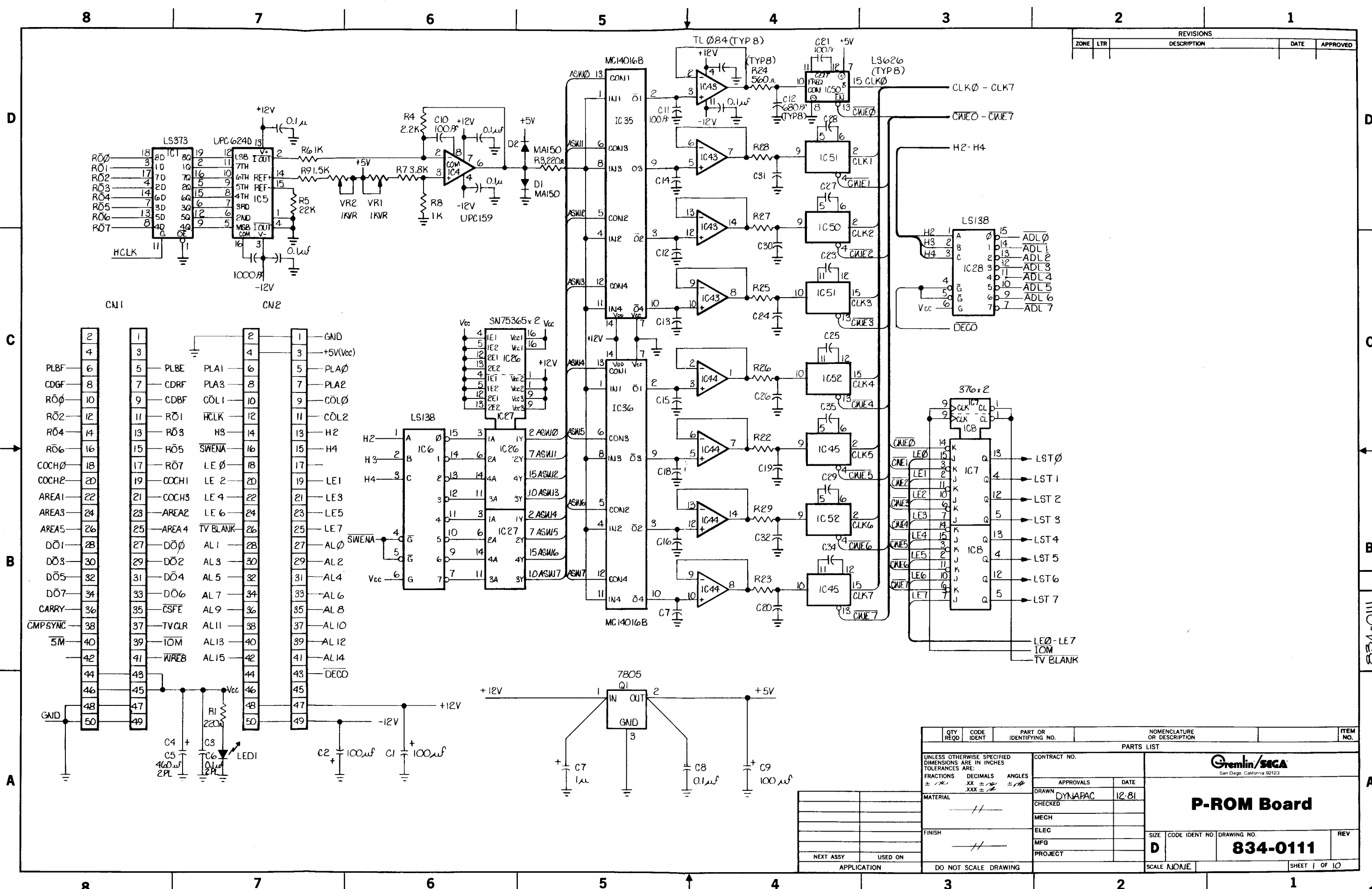

REVISIONS				
ZONE	LTR	DESCRIPTION	DATE	APPROVED

QTY REQD	CODE IDENT	PART OR IDENTIFYING NO.	NOMENCLATURE OR DESCRIPTION	ITEM NO.
PARTS LIST				
UNLESS OTHERWISE SPECIFIED DIMENSIONS ARE IN INCHES TOLERANCES ARE:		CONTRACT NO.		
FRACTIONS ± .001	DECIMALS .XX ± .005	ANGLES XXX ± .1°	APPROVALS	DATE
MATERIAL		DRAWN DYNAPAC 12-81		
FINISH		CHECKED		
NEXT ASSY		MECH		
USED ON		ELEC		
APPLICATION		MFG		
DO NOT SCALE DRAWING		PROJECT		
SCALE NONE		SIZE CODE IDENT NO. DRAWING NO. REV		
		D 834-0111		
		SHEET 1 OF 10		

834-0111



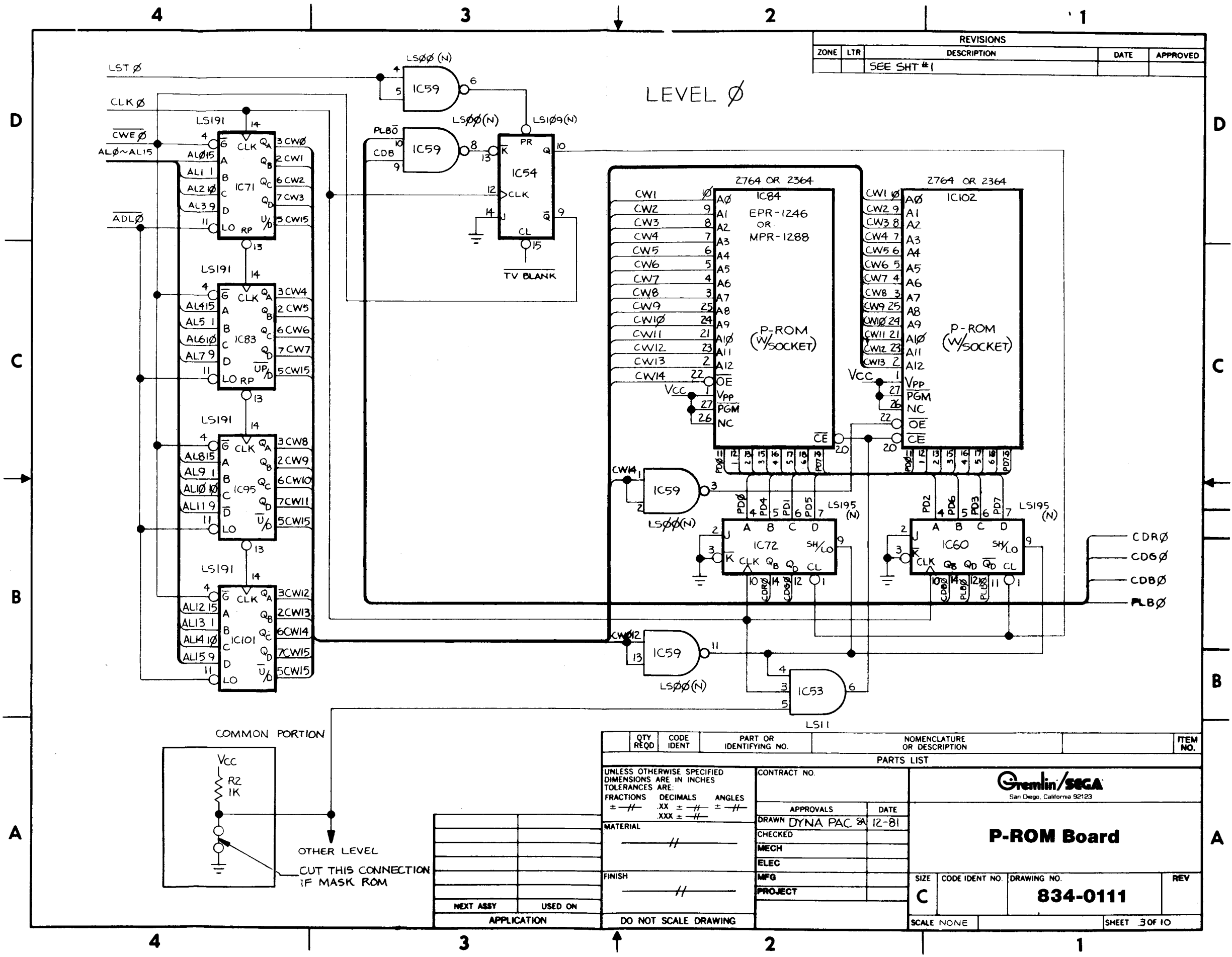

REVISIONS				
ZONE	LTR	DESCRIPTION	DATE	APPROVED
		SEE SHT #1		

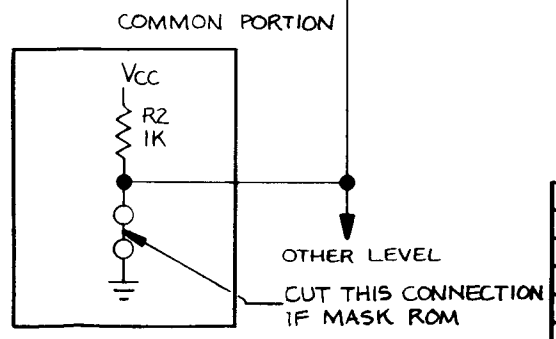

QTY REQD	CODE IDENT	PART OR IDENTIFYING NO.	NOMENCLATURE OR DESCRIPTION	ITEM NO.
PARTS LIST				
UNLESS OTHERWISE SPECIFIED DIMENSIONS ARE IN INCHES TOLERANCES ARE:		CONTRACT NO.		
FRACTIONS DECIMALS ANGLES		APPROVALS DATE		
± #/16 ± .## ± °/16		DRAWN DYNA PAC SA 12-81		
MATERIAL		CHECKED		
FINISH		MECH		
NEXT ASSY USED ON		ELEC		
APPLICATION		MFG PROJECT		
DO NOT SCALE DRAWING		SIZE CODE IDENT NO. DRAWING NO. REV		
		C 834-0111		
		SCALE NONE SHEET 3 OF 10		



### P-ROM Board



REVISIONS				
ZONE	LTR	DESCRIPTION	DATE	APPROVED
		SEE SHT #1		

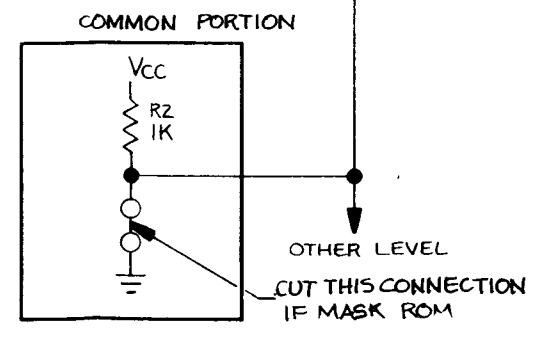
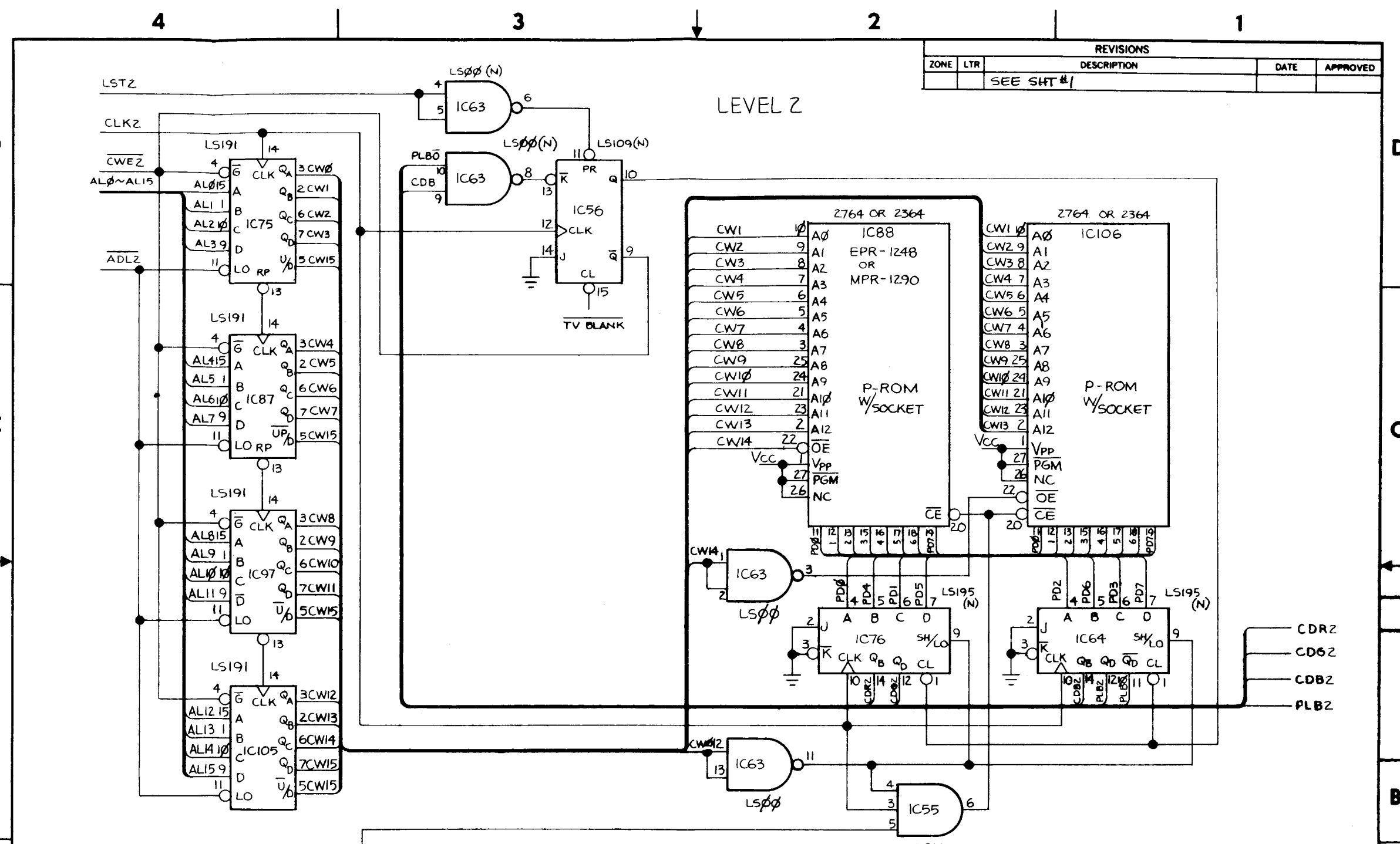

QTY REQD	CODE IDENT	PART OR IDENTIFYING NO.	NOMENCLATURE OR DESCRIPTION	ITEM NO.
PARTS LIST				
UNLESS OTHERWISE SPECIFIED DIMENSIONS ARE IN INCHES TOLERANCES ARE:		CONTRACT NO.		
FRACTIONS	DECIMALS	ANGLES	APPROVALS	
± #	.XX ± #	± #	DRAWN DYNA PAC SA	DATE 12-81
MATERIAL		MECH		
FINISH		ELEC		
NEXT ASSY		MFG		
USED ON		PROJECT		
APPLICATION		DO NOT SCALE DRAWING		

<b>Gremlin/SGCA</b> San Diego, California 92123	
<b>P-ROM Board</b>	
SIZE C	CODE IDENT NO. DRAWING NO. <b>834-0111</b>
SCALE NONE	SHEET 5 OF 10



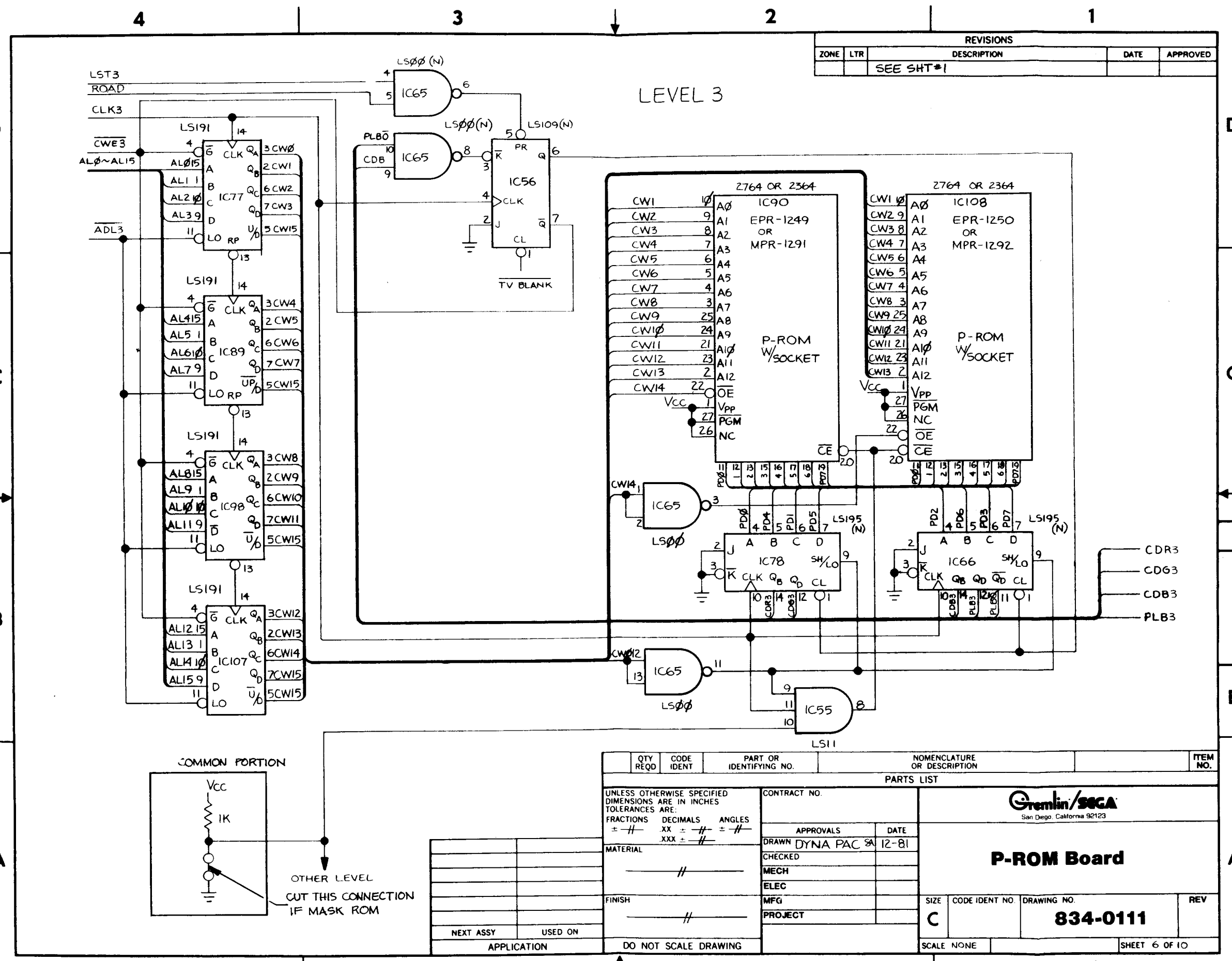

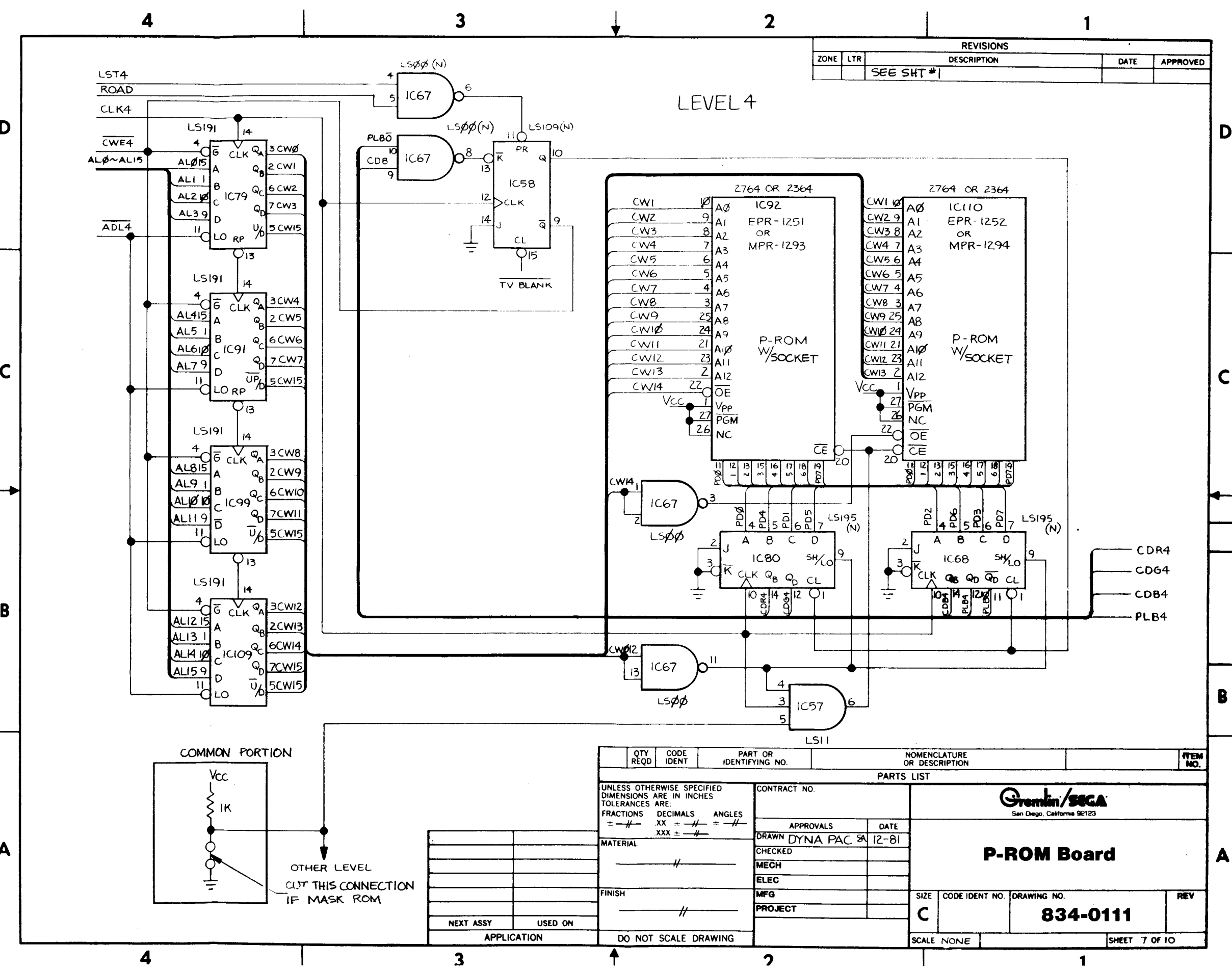
REVISIONS				
ZONE	LTR	DESCRIPTION	DATE	APPROVED
		SEE SHT #1		

QTY REQD	CODE IDENT	PART OR IDENTIFYING NO.	NOMENCLATURE OR DESCRIPTION	ITEM NO.
PARTS LIST				
UNLESS OTHERWISE SPECIFIED DIMENSIONS ARE IN INCHES TOLERANCES ARE:			CONTRACT NO.	
FRACTIONS	DECIMALS	ANGLES	APPROVALS	
± #/	.XX ± #/	± #°	DATE	
	.XXX ± #/		DRAWN DYNA PAC SA 12-81	
MATERIAL			CHECKED	
			MECH	
FINISH			ELEC	
			MFG	
NEXT ASSY	USED ON		PROJECT	
APPLICATION			SIZE	CODE IDENT NO.
DO NOT SCALE DRAWING			C	834-0111
			SCALE NONE	SHEET 7 OF 10

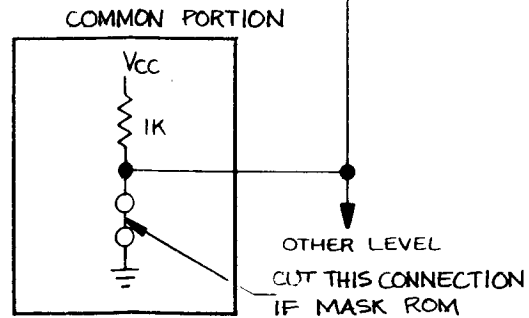





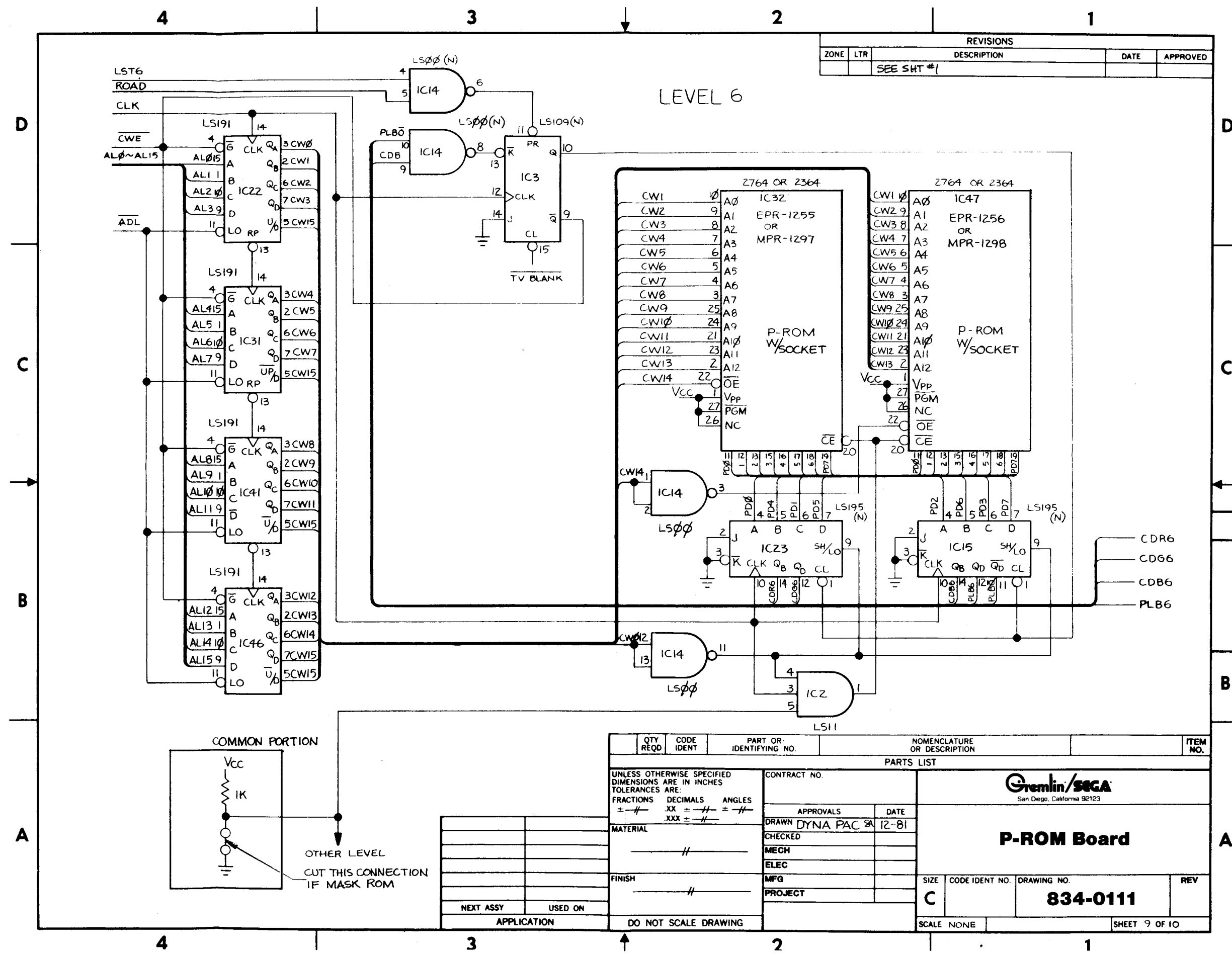

REVISIONS				
ZONE	LTR	DESCRIPTION	DATE	APPROVED
		SEE SHT #1		

LEVEL 6

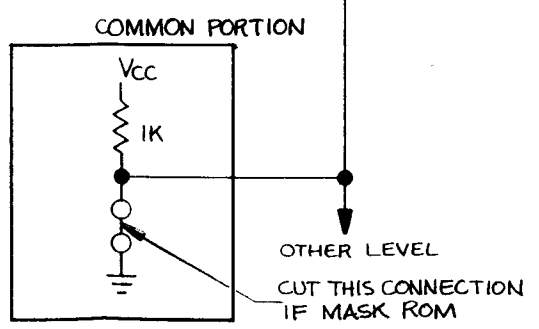
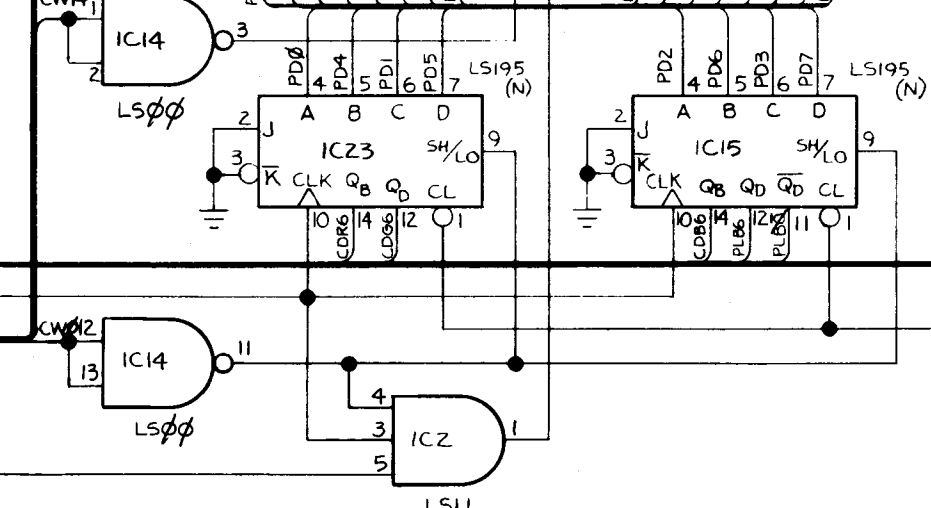
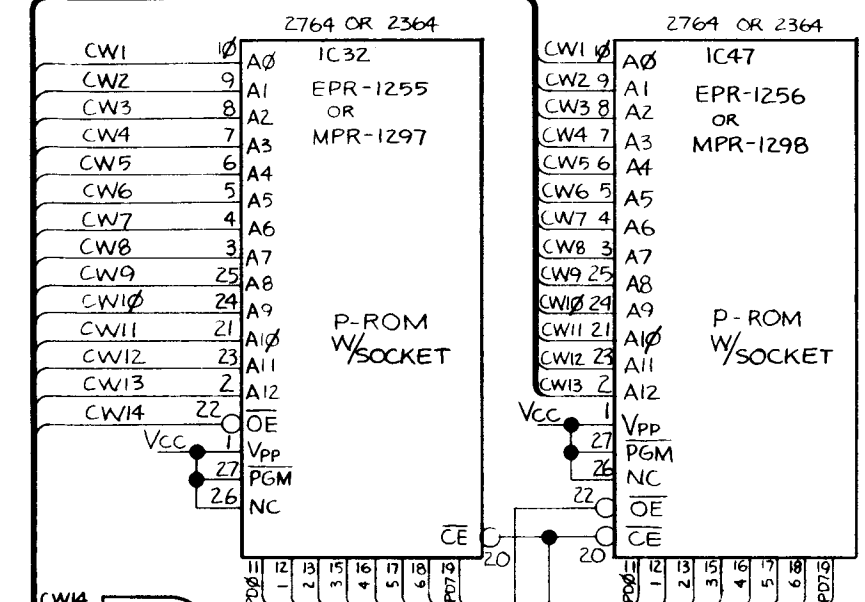

QTY REQD	CODE IDENT	PART OR IDENTIFYING NO.	NOMENCLATURE OR DESCRIPTION	ITEM NO.
PARTS LIST				
UNLESS OTHERWISE SPECIFIED DIMENSIONS ARE IN INCHES TOLERANCES ARE:		CONTRACT NO.		
FRACTIONS ± #/	DECIMALS .XX ± #/	ANGLES ° ± #/	APPROVALS	
MATERIAL			DATE	
FINISH			DRAWN DYNA PAC SA 12-81	
NEXT ASSY			CHECKED	
USED ON			MECH	
APPLICATION			ELEC	
DO NOT SCALE DRAWING			MFG	
			PROJECT	
SIZE C		CODE IDENT NO.	DRAWING NO.	REV
SCALE NONE		834-0111		
			SHEET 9 OF 10	

