



# SUPER SPACE ATTACK



ART NO.  
420-0272

MANUFACTURED BY

**Gremlin**<sup>®</sup>  
Industries, inc.

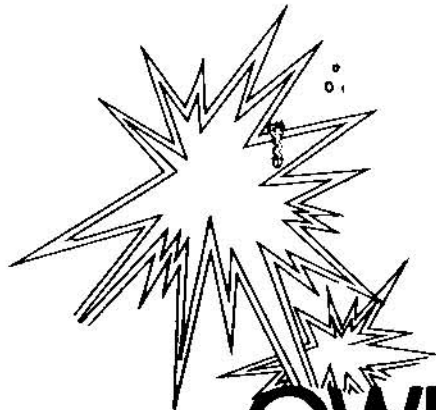

# OWNER'S MANUAL

SUPER SPACE ATTACK  
OPERATING INSTRUCTIONS  
AND  
SERVICE MANUAL

SUPER SPACE ATTACK OWNER'S MANUAL

Copyright © 1979 by Gremlin Industries, Inc. All Rights Reserved All the information contained herein is the exclusive proprietary property of GREMLIN INDUSTRIES, and is disclosed in confidence and may not be duplicated nor copied in whole or part nor be used for any purposes than that for which disclosed.

## TABLE OF CONTENTS

	PAGE
INTRODUCTION	1
IMPORTANT NOTE	2
REPACKAGING INSTRUCTIONS	3
GAME CONCEPT	4
OPTION SELECTION INSTRUCTIONS	6
MAINTENANCE PROCEDURES	7
TRANSFORMER VOLTAGE CONVERSION INSTRUCTIONS	Following Pages
SCHEMATICS	Following Pages

## INTRODUCTION

This is an electronic game that makes extensive use of digital integrated circuitry and television monitor circuitry. This manual assumes the maintenance technician possesses a general knowledge of solid state circuitry, microprocessor, TTL digital integrated circuitry and T.V. monitor concepts. Any individual NOT knowledgeable in these areas SHOULD NOT attempt repair of the electronic portion of this game. IT SHOULD BE NOTED THAT ANY ATTEMPT TO REPAIR THE GAME IN THE FIELD WITHOUT EXPRESS CONSENT OF THE FACTORY WILL IMMEDIATELY VOID THE WARRANTY!!!

### IMPORTANT NOTES:

- NEVER           replace any components with anything other than exact replacement parts. (See Parts List located on Service Schematics.
  
- NEVER           remove circuit boards/connections while power is on.
  
- DO NOT          replace the fuse with anything other than the proper value. A blown fuse indicates an overload condition within the game. Replacing the fuse with a higher value can cause severe damage to internal components if an overload occurs.
  
- ALWAYS          consult the manual before attempting repairs.
  
- CORRESPONDENCE   regarding this game should be addressed to:

GREMLIN INDUSTRIES, INC.  
8401 Aero Drive  
San Diego, California 92123  
(714) 277-8700

### IMPORTANT NOTE

An important service note is posted in this game and is repeated here for emphasis:

IF AT ANY TIME THE T. V. SCREEN SHOWS A MEANINGLESS DISPLAY  
OR THE GAME OTHERWISE MALFUNCTIONS, SIMPLY DROP A COIN INTO  
THE COIN MECHANISM. THIS SHOULD CORRECT THE PROBLEM. IF  
NOT, THE GAME REQUIRES SERVICE.

The circuitry in this game has been arranged so that the insertion of a quarter through the coin mechanism will reset the system. This clears up temporary problems caused by power line disturbances, static, etc.

#### SERVICE TECHNICIAN NOTE:

The system reset circuitry described above requires that the coin counter is attached to the system. If there is a coin counter problem and no replacement is available, the game will function properly if a 10K Ohm resistor is connected across the coin counter input pins to the video logic board.

## REPACKAGING INSTRUCTIONS

Should it be necessary to ship this game, follow the instructions below for game re-crating:

- A) If the original shipping bolts have been discarded (Ref.1), obtain four 5/16-18x1 3/4" hex head bolts with 5/16" flat washers. Carefully lay the game on its side and attach skid (Ref.2).
- B) Place game upright. Tape game keys to upper flange of operator's panel (Ref.3). Crate the game using appropriate shock-absorbent packing material (Ref.4). Include padding on all four corners of the game (Ref.5). After crating is completed, secure package with strapping (Ref.6).

NOTE: If the game is to be shipped to GREMLIN for service or repair, attach a tag identifying the distributor and indicate the service or repair to be made; include the full serial number of the game. GAME MUST BE SHIPPED PREPAID.

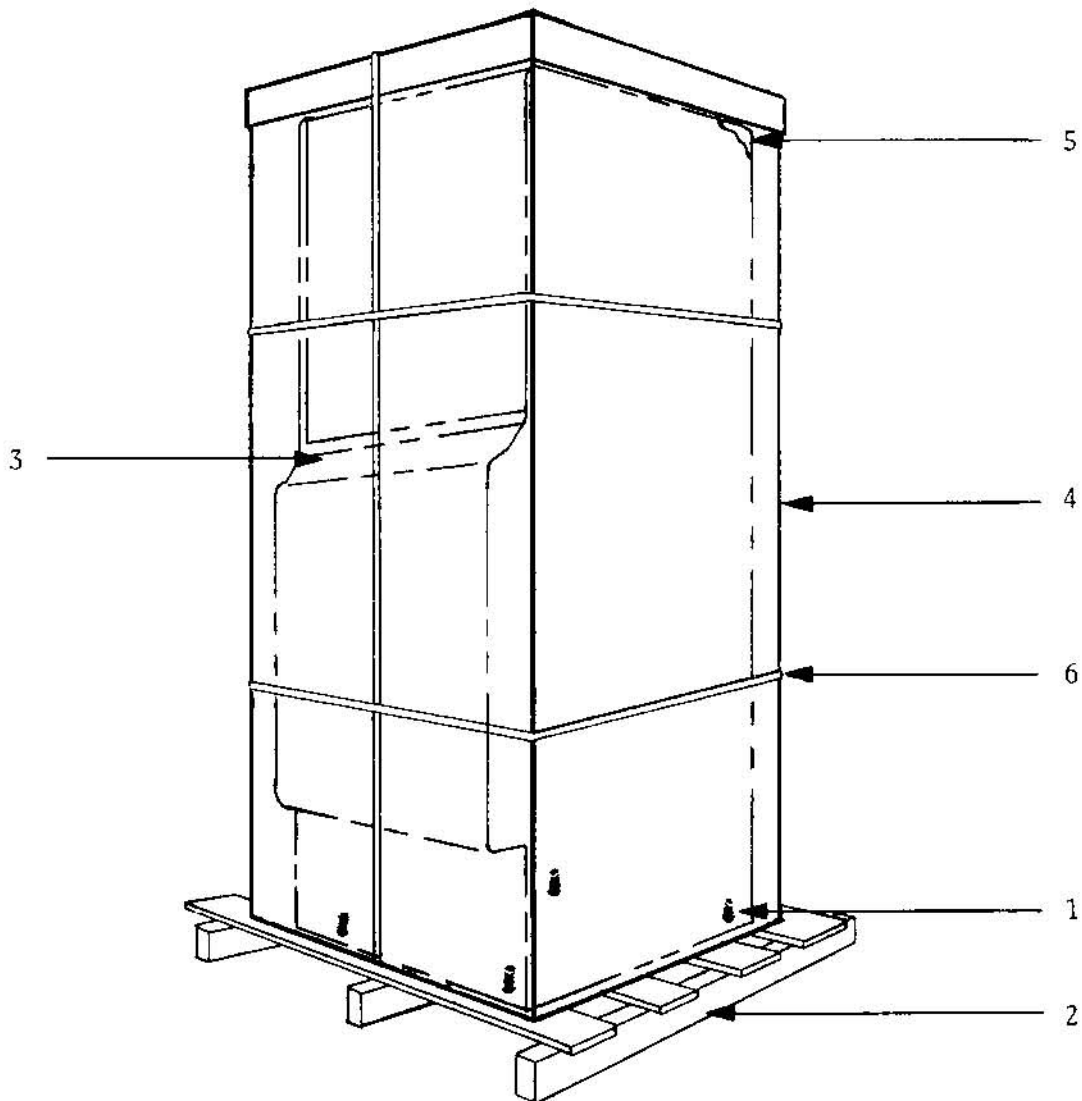

## SUPER SPACE ATTACK- GAME CONCEPT

SUPER SPACE ATTACK is a one or two player game, in which players defend their laser bases from the attacking space creatures. When the game begins, five rows of creatures line up on the screen. The lowest row begins firing at the player's laser base which the player moves left or right across the screen. The player positions his base and fires at the creatures above, scoring 100 points for any creature hit in the lower two rows, 200 points for a hit in the third and fourth rows, and 300 points for a hit in the highest row. As more creatures are hit, the rest begin to move faster toward the bottom of the screen. Also, the creatures' missiles are released at a faster rate.

To prevent his base from being hit, the player can move it under the cover offered by four force fields, just above the base. The first few laser bursts penetrate the force field, but do not pass through. Then, when a path is cut through the field, the laser fire can pass. Likewise, the creatures' projectiles destroy part of the force field, until a path is cut for them to pass. Toward the end of a game, the force fields are usually destroyed; the game then becomes even more challenging.

A small enemy UFO floats across the top of the screen during game play, to provide another target. When hit, the UFO explodes, scoring 1000, 1200, 1500, or 1800 points. This first UFO appears only during game play. A second one appears after each time the player clears the screen of creatures. This bonus UFO zig-zags from the top of the screen toward the bottom. If the player hits it, bonus points are awarded and the player gains an additional laser base.

When the player's laser base is destroyed the first time, a new one is added, and the action resumes. Each time all the creatures are destroyed and the screen resets, the five rows of creatures are arranged closer and closer to the player's base. The number of bases with which a player starts is operator adjustable. The game is shipped with the three laser base option selected; four, five, or six bases can be selected by internal jumpers. Also operator selectable is the number of points, 10,000 or 15,000, at which a free laser base is awarded. The game is shipped with the 10,000 point option enabled.

## SUPER SPACE ATTACK- GAME CONCEPT- cont'd

A final option is available to display, or not to display, on the screen the number of credits accepted. The maximum number of credits counted by the game is 99. This information is displayed in the bottom right corner of the screen. Instructions for selecting these options are included in this manual.

In the two player mode, the game action is the same as in the one player, except that the game allows players to take turns. The game then remembers where each player leaves off at the end of his turn. It also displays the three highest scores at the top of the screen for players to challenge.



## SELECTING OPTIONS FOR SUPER SPACE ATTACK

The following describes the procedure for selecting any of the game options.

1. Locate the Molex pin connector labelled P3 on the logic board.
2. To select any of the options, simply connect one or both jumper wires, as necessary, to the pin connector. See the chart, below:

<u>TO SELECT:</u>	<u>CONNECT JUMPER TO PIN #:</u>
3 laser bases at game start	no jumper (game shipped this way)
4 laser bases at game start	2
5 laser bases at game start	3
6 laser bases at game start	4
Extra base awarded when second UFO hit	no jumper (game shipped this way)
No base awarded	1
Bonus (extra base) at 10,000 points	no jumper (game shipped this way)
Bonus at 15,000 points	6
Display number of credits	no jumper (game shipped this way)
Do not display credits	9
(Ground	10)

## MAINTENANCE PROCEDURES- SPACE ATTACK

### I. POWER SUPPLY (refer to drawing #815-0020, sheet 4)

1. Remove output connectors from power supply.
2. Make these initial tests: (GND to BLACK lead on C18, 9000 mfd capacitor)
  - a) +9 V DC on POSITIVE terminal of C18
  - b) +17-19 V on C6 (4700 mfd. cap.)
  - c) -17-19 V on C5 (4700 mfd. cap.)
  - d) -12 V at pin 11 (adjustable by trim pot R42)
  - e) +12 V at pin 12 (adjustable by trim pot R8)
  - f) +5 V at pins 18-20 (adjustable by trim pot R9)
  - g) GND (ground, 0 V) at pins 14-16
  - h) 2-3 V AC at pin 13 (Don't forget to change meter scale to AC)
3. Check these voltages again with the logic board connected. If any are wrong, a loading problem exists in the logic board, most likely. Possible causes of a short on the logic board could be: U73, C21, C25, or C26.

### II. SOUND BOARD (refer to drawing #826-0002)

1. If no sounds are produced:
  - a) check connections between logic board (labelled "Sound Out") and sound board and between the sound board and power supply.
  - b) If these are good, check IC U16 on the logic board, pins 2,5,6,9,12, 15,16, and 19 for outputs when each sound is produced.
  - c) If the outputs are present, check the output of the sound board, pin 22. If the signals are present here (use an oscilloscope for best results) check the amplifier circuit on the power supply, specifically, U4, Q8 and Q9.

#### 2. If some sounds are produced, but not all:

- a) repeat steps a and b, above.
- b) If these prove OK, check the specific circuit for each sound:

SOUND TYPE	SOUND BOARD PIN #	CHECK THESE PARTS
Ship hit	Pin 2	U8, U9, U10
UFO hit	Pin 3	U17, U18, U19, Q9

MAINTENANCE PROCEDURES- cont'd.

Laser	Pin 4	U14, U4, U15, U16, Q5, U9, U10
UFO #1	Pin 6	U1,U2,U3,Q1,Q2
UFO #2	Pin 7	U11,U5,Q3,Q4,U6
Saucer	Pin 8	U24,U25,Q11,U20

III. LOGIC BOARD (refer to drawing #826-0004)

1. Game does not reset at power on: (see sheet 5)
  - a) Check connector pin 3 on logic board for 3V AC signal. Also, check Q10, Q11, U55, U54, and U71.
2. No video: (see sheet 5)
  - a) Check U48 (part #315-0042) for video signals. Also, check U41, Q6 and Q7 for the video signals.
3. Game does not coin on: (see sheet 5)
  - a) Check coin switch connections to the logic board; make sure the coin switch is wired correctly.
  - b) Check U12, pins 3 and 11 for a pulse each time the coin switch is activated. Also, check U11 and U13.
  - c) Check also for the 4 msec. pulses at pin 7 of U10. These pulses serve as timing for the video circuit. Also, pin 5, U11; pin 6, U13.
  - d) If a game is started only occasionally when a coin is deposited, the coin switch wire may need to be adjusted for a lighter, or heavier, tension.
  - e) If the coin counter does not activate, check U12, pin 3 for a pulse each time a coin is inserted; also, check Q1 and Q2. (see sheet 5)
4. No  $\emptyset$ 1 clock pulses to the microprocessor: (see sheet 4)
  - a) check for pulses at the crystal, Y1.
  - b) check for pulses at pin 6 of U68; at pin 6 of U49; and at pin 4 of U54.
5. No player control: (see sheet 5)
  - a) Make sure the player control connections from the switches to the logic board are intact. Ensure that each switch is connected.
  - b) If these are good, check for an output from U1 as you push each switch.
6. Random display on the screen:
  - a) If the screen shows what appears to be a meaningless display, and

MAINTENANCE PROCEDURES- cont'd.

it cannot be cleared by activating the coin switch, several different parts of the circuit should be considered:

One or more RAM's, U56 through U63 (sheet 5)

One of the programmed IC's, or EPROM's (sheet 6) Check their sockets first.

The reset circuit is not working. (see #1, above)

The microprocessor is bad. (sheet 4)

Data or address bus problem (e.g. U33 or U34, sheet 4, could be bad.)

## SPECIAL VOLTAGE CONVERSION INSTRUCTIONS

To operate this game on voltages of 100, 115, or 230 VAC, the following changes must be made in the power supplies of BOTH the game AND video monitor:

### 1. Game Power Supply

First determine which terminal configuration is used on your transformer. There are 3 different configurations, as shown below:

TO CONVERT TO 100 VAC refer to Figures 1, 2, & 3:

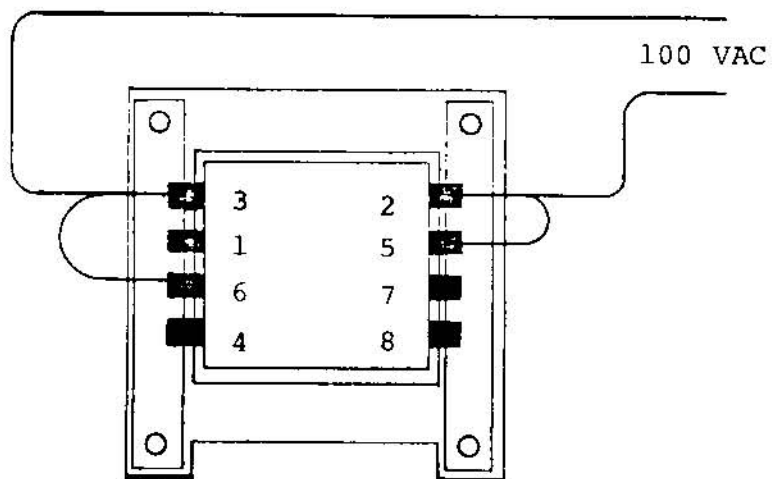

(Terminals 9, 10, & 11  
located on far side)

Fig. 1

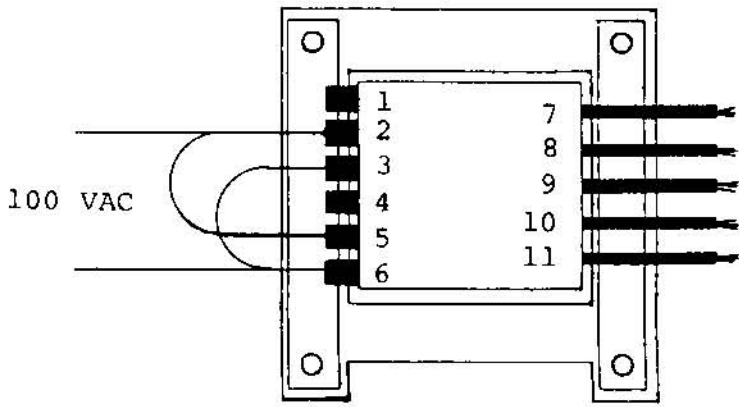

Fig. 2

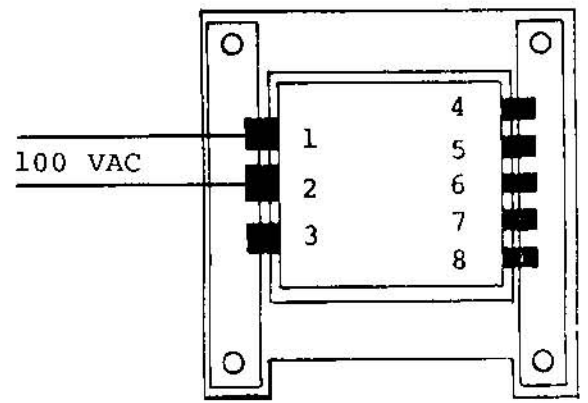
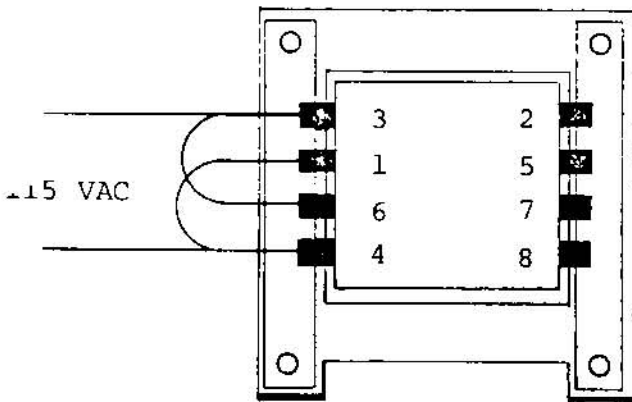

Fig. 3

TO CONVERT TO 115 VAC refer to Figures 4, 5, 6:



(Terminals 9, 10 & 11 located on far side)

Fig. 4

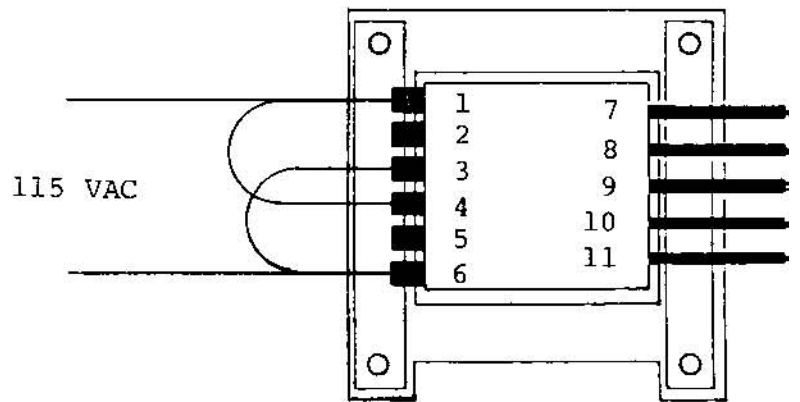

Fig. 5

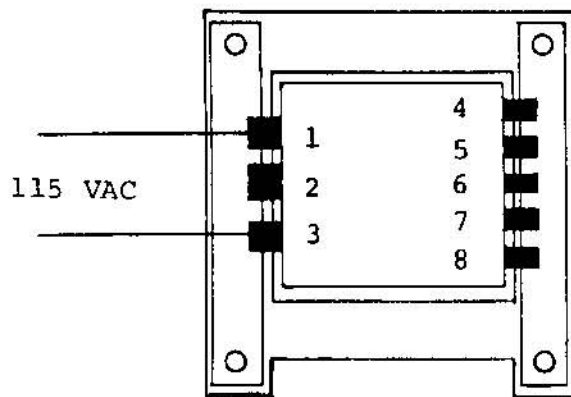
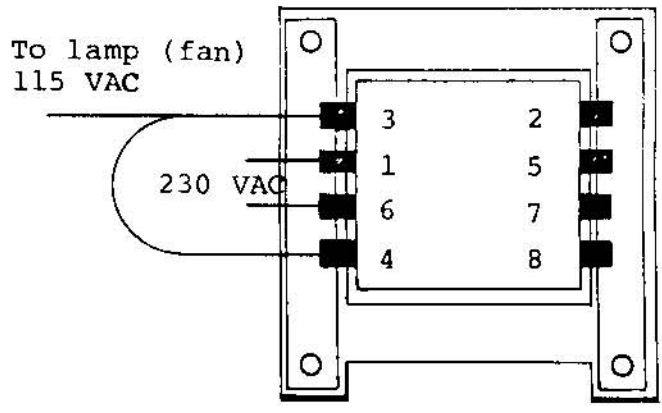
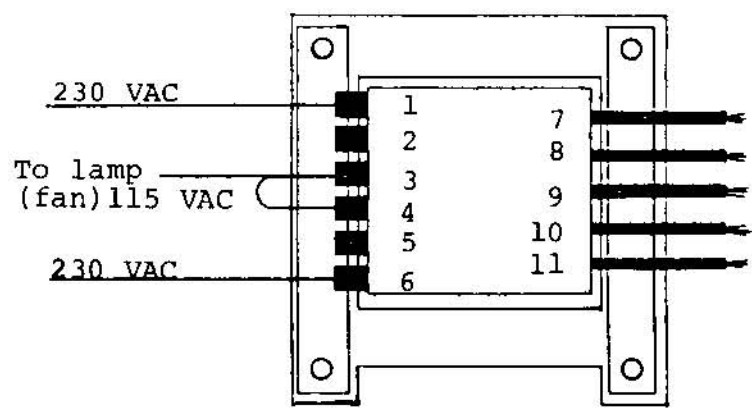

Fig. 6

TO CONVERT TO 230 VAC refer to Figures 7, 8, 9:



(Terminals 9, 10 & 11 located on far side)  
Fig. 7



NOTE: Terminals 3 & 4 must be connected if there is no lamp or fan.

Fig. 8

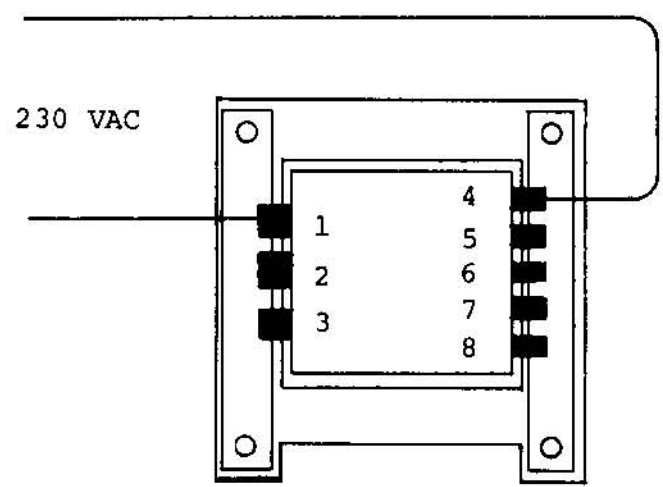

Fig. 9

## 2. Video Monitor Power Supply

In addition to the above changes, the transformer in the video monitor must also be converted to either 100, 115, or 230 VAC. This is done simply by removing the terminal cover in the back of the monitor chassis (located to the side of the power transformer, and labelled "VOLTAGE SELECTION TAPS"). Then, move the jumper wire to the proper voltage terminal.



Gromlin Industries, Inc. San Diego, California 92123		PARTS LIST		TITLE		826-0002		SH 2 OF 6		F REV	
ITEM NO	PART NO	QTY PER ASSY		DESCRIPTION	REF DES	DWG NO					
1	151-0001	10		CAP CER .05 $\mu$ f 50V	C3,13,15,21,28,34,41,43,45,52						
2	151-0012	12		CAP CER .1 $\mu$ f 50V	C2,14,20,27,33,38,39,40,44,51,56,50						
3	152-0001	2		CAP FILM .1 $\mu$ f 100V	C5,17						
4	152-0002	1		CAP FILM .22 $\mu$ f 100V	C4						
5	152-0011	2		CAP FILM .15 $\mu$ f 100V	C36,37						
6	152-0007	2		CAP FILM .001 $\mu$ f 250V	C30,31						
7	152-0010	2		CAP FILM .022 $\mu$ f 100V	C18,25						
8	152-0012	1		CAP FILM .047 $\mu$ f 200V	C42						
9	152-0017	1		CAP FILM .33 $\mu$ f 100V	C7						
10	152-0018	1		CAP FILM .01 $\mu$ f 250V	C55						
11	152-0020	1		CAP FILM .47 $\mu$ f 100V	C54						
12	153-0002	4		CAP TANT 1 $\mu$ f 25V	C6,26,32,49						
13	153-0003	1		CAP TANT 2.2 $\mu$ f 25V	C16						
14	153-0004	1		CAP TANT 4.7 $\mu$ f 25V	C9						
15	153-0006	3		CAP TANT 33 $\mu$ f 25V	C11,12,19						
16	170-0110	1		P.C. BOARD							
17	212-0021	1		CONN MALE 10 PIN							
18	212-0031	1		CONN MALE 12 PIN							
19	313-0004	10		IC LM741 EN	U2,3,5-7,9,10,15,16,18						

**Crescent Industries, Inc.**  
San Diego, California 92123

**PARTS LIST**

**TITLE**

Y-2 SOUND BOARD

826-0002  
DWG NO

SH 3  
OF 6

F  
REV

ITEM NO	PART NO	QTY PER ASSY		DESCRIPTION	REF DES
20	314-0001	9		IC TIMER LM 555	U1, 8, 11, 14, 17, 19, 20, 24, 25
21	315-0035	1		IC MM 5837	114
22	471-0102	10		RES 1K OHM 1/2W 5%	R 3, 5, 9, 12, 16, 30, 43, 49, 78, 77
23	471-0103	15		RES 10K OHM 1/2W 5%	R 6, 8, 13, 15, 21-25, 44-48, 75
24	471-0104	2		RES 100K OHM 1/2W 5%	R 20, 80
25	471-0153	1		RES 15K OHM 1/2W 5%	R 59
26	471-0154	3		RES 150K OHM 1/2W 5%	R 2, 42, 82
27	471-0183	6		RES 18K OHM 1/2W 5%	R 1, 19, 28, 41, 53, 72
28	471-0223	4		RES 22K OHM 1/2W 5%	R 27, 52, 60, 83
29	471-0225	1		RES 2.2M OHM 1/2W 5%	R 56
30	471-0272	1		RES 2.7K OHM 1/2W 5%	R 62
31	471-0473	2		RES 47K OHM 1/2W 5%	R 50, 58
32	471-0682	1		RES 6.8K OHM 1/2W 5%	K17
33	471-0683	4		RES 6.8K OHM 1/2W 5%	R 4, 63, 76, 54
34					
35	471-0823	1		RES 82K OHM 1/2W 5%	R 29
36	475-0008	5		POT (ARLEN) 50K OHM	R 16, 24, 51, 61, 81
37	481-0006	9		DIODE 1N914	D1-D9



Greenline Industries, Inc.  
San Diego, California 92122

PARTS LIST

TITLE  
ASSY BASIC W.C.B.D.

800-0031  
DWG NO

SH 2  
OF 5

A  
REV

ITEM NO	PART NO	QTY PER ASSY		DESCRIPTION	REF DES
1	151-0005	1		CAP CER 680 pf 50V	C39
2	151-0012	54		CAP CER .1 pf 50V	C3,5,7-11,13-17,22,25, C27-38,C40-67
3	152-0001	1		CAP FILM .1 pf 100V	C4
4	152-0017	1		CAP FILM .33 pf 100V	C24
5	153-0001	6		CAP TANT 10 pf 25V	C12,20,21,23,26,68
6	153-0002	1		CAP TANT 1 pf 25V	C19
7	170-0150	1		PCB C.V. LOGIC	
8	211-0004	6		CONN PIN TEST PT	TP1-TP4,GND
9	212-0004	2		CONN M 4 PIN	
10	212-0021	3		CONN M 10 PIN	
11	212-0031	1		CONN M 12 PIN	
12	213-0001	6		SKT 24 PIN DUAL INLN	XU22-XU27
13	213-0004	12		SKT 16 PIN DUAL INLN	XU33,XU34,XU56-XU63, XU65,XU66
14	213-0005	2		SKT 40 PIN DUAL INLN	XU48,XU53
15	213-0008	3		SKT 20 PIN DUAL INLN	XU1,XU16,XU19
16	230-0009	1		XTAL CLK 15.46848	Y1
17	313-0023	1		IC 320T-5.0	U73
18	314-0001	2		IC NE 555	U10,U55

Crescent Industries, Inc. San Diego, California 92123		PARTS LIST		TITLE ASSY BASIC V.I.C.B.D.		800-0031 DWG NO		SH 3 OF 5		A REV	
ITEM NO	PART NO	QTY PER ASSY		DESCRIPTION	REF DES						
19	314-0015	1		IC 7404	U54						
20	314-0018	3		IC 74LS00	U4, U12, U32						
21	314-0019	2		IC 74LS04	U35, U64						
22	314-0040	3		IC 74LS125	U13, U46, U47						
23	314-0046	1		IC 74LS04	U68						
24	314-0053	4		IC 74LS175	U49-U51, U67						
25	314-0055	2		IC 74LS244	U1, U19						
26	314-0058	5		IC 74LS08	U37-U39, U41, U71						
27	314-0059	1		IC 74LS10	U52						
28	314-0061	1		IC 74LS42	U40						
29	314-0062	2		IC 74LS74	U11, U72						
30	314-0078	1		IC 74LS02	U36						
31	314-0092	2		IC 8216	U33, U34						
32	315-0039	8		IC 4K RAM 12V	U56-U63						
33	315-0031	1		IC Z80 MK3880	U53						
34	315-0042	1		IC VID INTERFACE	U48						
35	314-0093	1		IC 74LS374	U16						
36	316-0042	1		IC PROM 32XB SEQ	U66						
37	316-0043	1		IC PROM 32XB CTL	U65						
38	390-0003	1		LED RED	D4						
39	471-0011	1		RES 10 OHM 1/2W 5%	R50						
40	471-0102	7		RES 1K OHM 1/2W 5%	R7-R11, R32, R37						
41	471-0103	1		RES 10K OHM 1/2W 5%	R6						

**Greenlin Industries, Inc.**  
San Diego, California 92123

**PARTS LIST**

**TITLE**  
ASSY BASIC V.I.C.B.D.

**DWG NO**  
800-0031

**SH 4 OF 5**  
**A REV**

ITEM NO	PART NO	QTY PER ASSY			DESCRIPTION	REF DES
42	471-0104	3			RES 100K OHM 1/2W 5%	R42-R44
43	471-0222	6			RES 2.2K OHM 1/2W 5%	R20-R25
44	471-0223	1			RES 22K OHM 1/2W 5%	R3
45	471-0331	6			RES 330 OHM 1/2W 5%	R30,R31,R33,R34,R45, R46
46	471-0471	1			RES 470 OHM 1/2W 5%	R49
47	471-0472	3			RES 4.7K OHM 1/2W 5%	R5, R47, R48
48	471-0750	1			RES 75 OHM 1/2W 5%	R41
49	475-0001	1			POT 10K PC MTV	R4
50	477-0002	2			RES PACK 15 X 2.2K	RPI, RP3
51	481-0006	3			DIODE 1N914/1N4148	D1, D2, D5
52	482-0006	1			XSTR 2N4403	Q6
53	482-0010	1			XSTR PE8050	Q2
54	482-0014	4			XSTR 2N4401	Q1, Q7, Q10, Q11
55	530-0006	1			HEAT SINK 295-1	

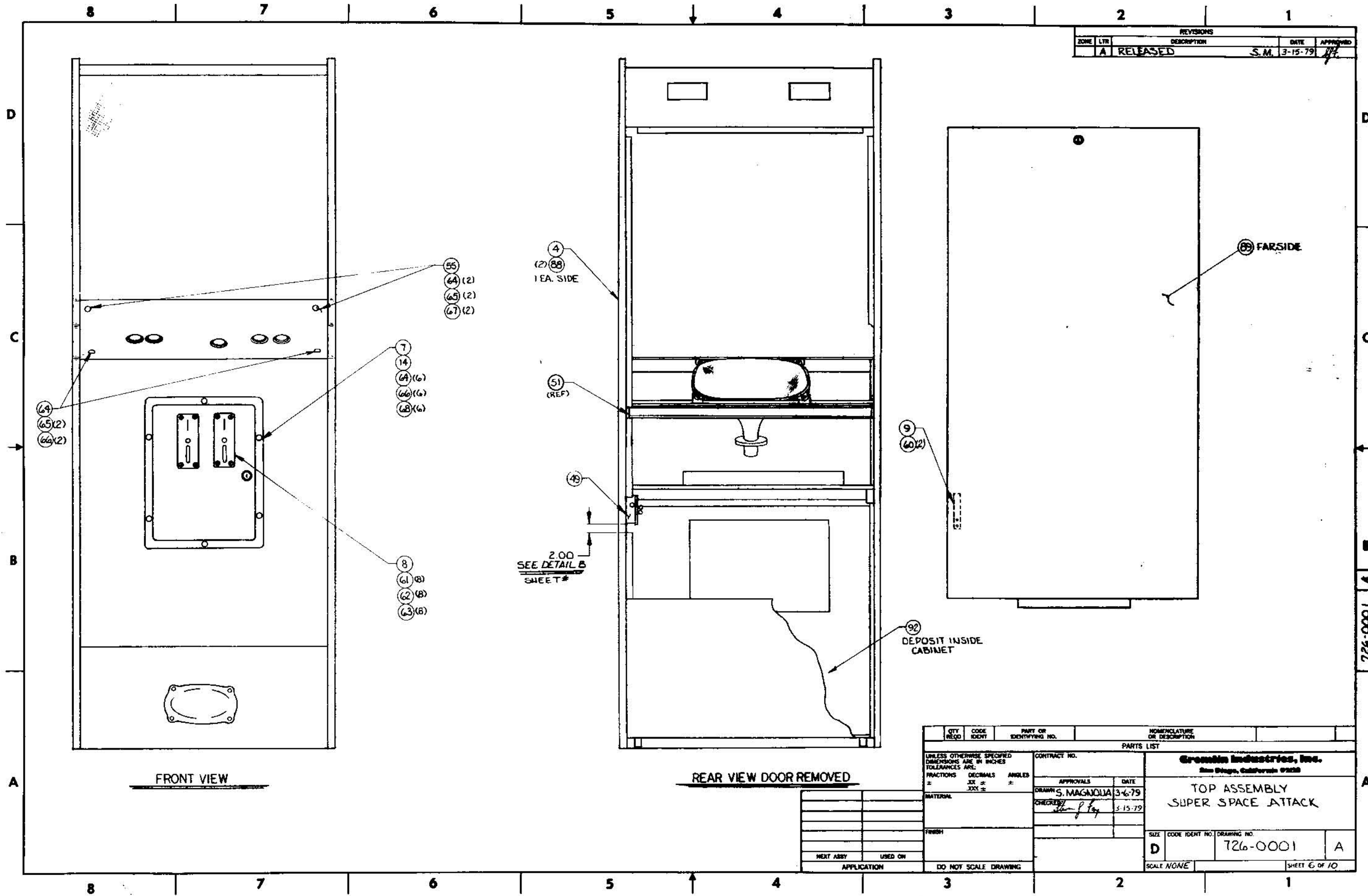

REVISIONS				
ZONE	LTR	DESCRIPTION	DATE	APPROVED
A	RELEASED		S.M. 3-15-79	[Signature]

FRONT VIEW

REAR VIEW DOOR REMOVED

QTY	CODE	PART OR IDENTIFYING NO.	NOMENCLATURE OR DESCRIPTION
PARTS LIST			
UNLESS OTHERWISE SPECIFIED DIMENSIONS ARE IN INCHES TOLERANCES ARE:		CONTRACT NO.	
FRACTIONS	DECIMALS	ANGLES	APPROVALS
±	.XX ±	±	DATE
MATERIAL	.XXX ±		DRAWN S. MAGNOLIA 3-6-79
			CHECKED [Signature] 3-15-79
FINISH			
NEXT ASSY	USED ON		
APPLICATION		DO NOT SCALE DRAWING	
		<b>Grosvenor Industries, Inc.</b> 2500 Elgin, California 92520 <b>TOP ASSEMBLY SUPER SPACE ATTACK</b>	
SIZE	CODE IDENT NO.	DRAWING NO.	
D		726-0001	A
SCALE	NONE		SHEET 6 OF 10

726-0001 A

REVISIONS				
ZONE	LTR	DESCRIPTION	DATE	APPROVED
A	RELEASED		S.M. 3-15-79	<i>[Signature]</i>

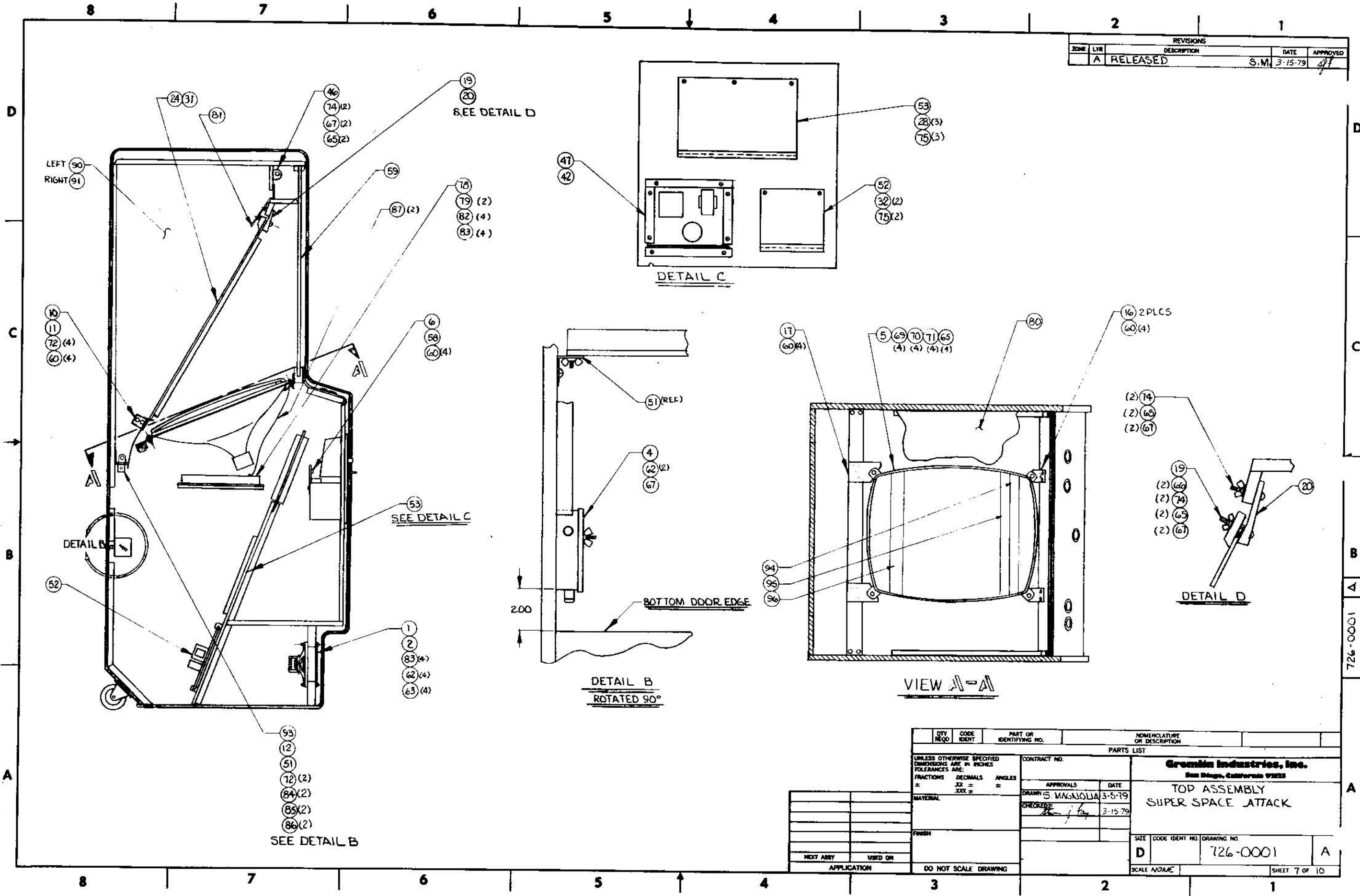

QTY REQD	CODE IDENT	PART OR IDENTIFYING NO.	NOMENCLATURE OR DESCRIPTION
PARTS LIST			
UNLESS OTHERWISE SPECIFIED DIMENSIONS ARE IN INCHES TOLERANCES ARE:		CONTRACT NO.	
FRACTIONS	DECIMALS	ANGLES	APPROVALS
±	.XX ±	±	DATE
±	.XXX ±	±	DRAWN S. MAGNOLIA 3-5-79
MATERIAL		CHECKED <i>[Signature]</i> 3-15-79	
FINISH		DATE	
NEXT ASSY		USED ON	
APPLICATION		DO NOT SCALE DRAWING	
<b>Granite Industries, Inc.</b> San Diego, California 92123			SIZE CODE IDENT NO. DRAWING NO. D 726-0001 A
SCALE N/A			SHEET 7 OF 10

726-0001



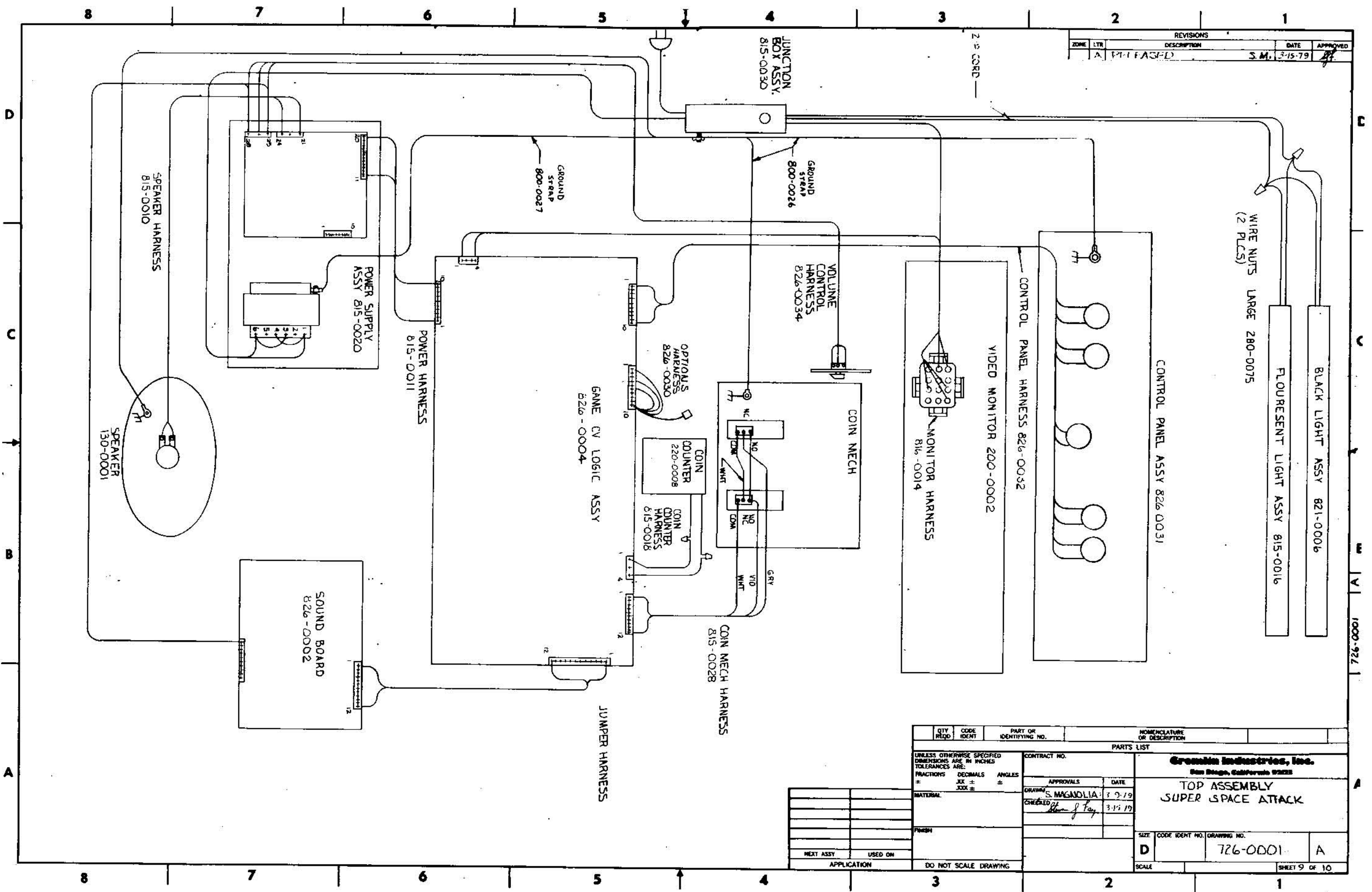

REVISIONS			
ZONE	LTR	DESCRIPTION	DATE
A		PHASED	S.M. 3-15-79

PARTS LIST		NOMENCLATURE OF DESCRIPTION	
UNLESS OTHERWISE SPECIFIED DIMENSIONS ARE IN INCHES TOLERANCES ARE:		CONTRACT NO.	
FRACTIONS	DECIMALS	ANGLES	APPROVALS
±	.XX ±	±	DATE
	.XXX ±		
MATERIAL		DRAWN S. MAGNOLIA 3-9-79	
FINISH		CHECKED <i>[Signature]</i> 3-15-79	
NEXT ASSY		USED ON	
APPLICATION		DO NOT SCALE DRAWING	
SCALE		SIZE CODE IDENT NO. DRAWING NO.	
		D 726-0001 A	
		SHEET 9 OF 10	

1000-921

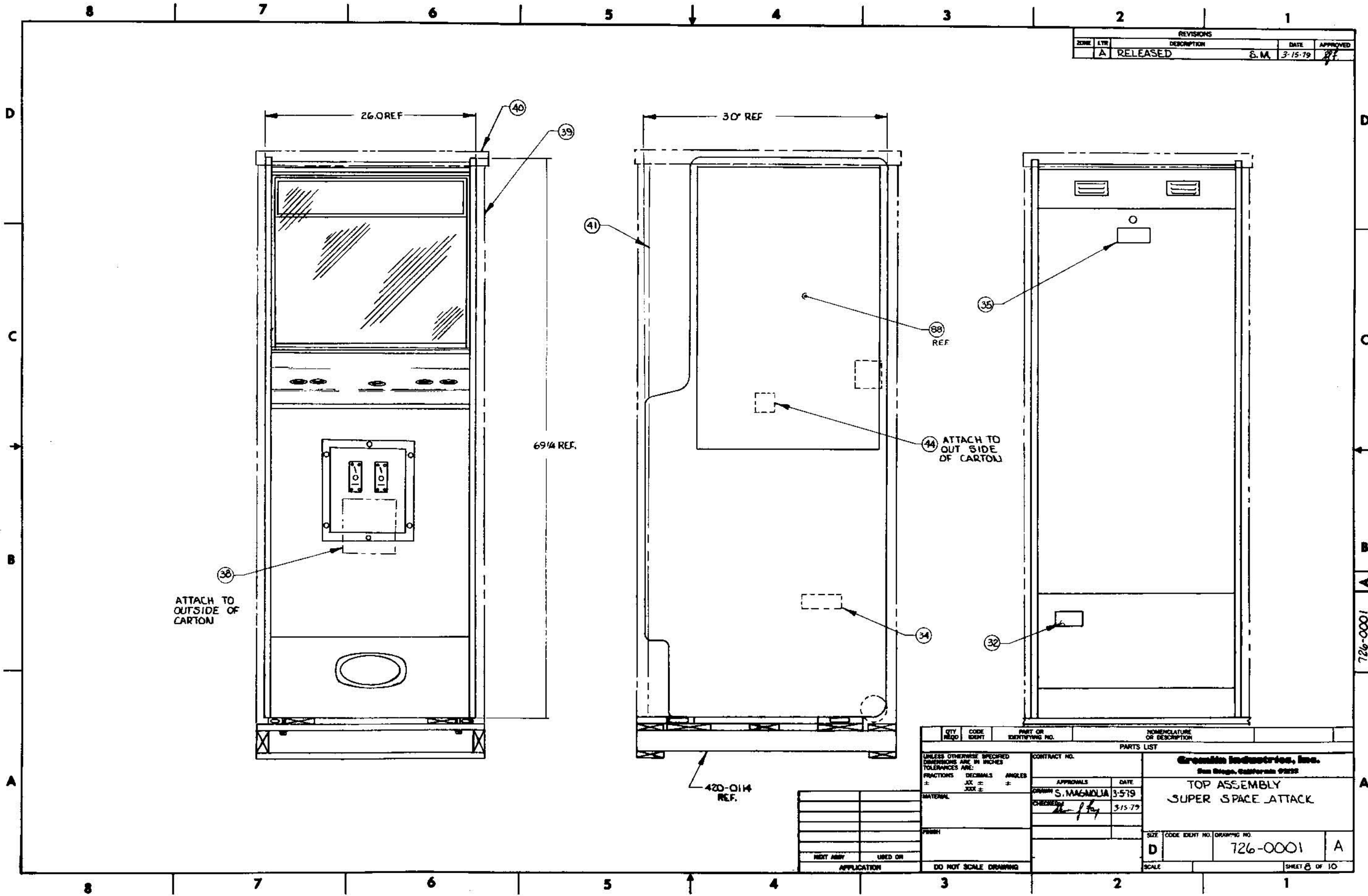

REVISIONS				
REV	BY	DESCRIPTION	DATE	APPROVED
A		RELEASED	S.M. 3-15-79	[Signature]

QTY REQD	CODE IDENT	PART OR IDENTIFYING NO.	NOMENCLATURE OR DESCRIPTION
PARTS LIST			
UNLESS OTHERWISE SPECIFIED DIMENSIONS ARE IN INCHES TOLERANCES ARE:		CONTRACT NO.	
FRACTIONS	DECIMALS	ANGLES	
±	.XX ±	±	
	.XXX ±		
MATERIAL		APPROVALS	
FINISH		DRAWN S. MAGNOLIA	DATE 3-5-79
NEXT ARMY USED ON		CHECKED [Signature]	DATE 3-15-79
APPLICATION		DO NOT SCALE DRAWING	
		<b>Green Industries, Inc.</b> San Diego, California 92122 <b>TOP ASSEMBLY SUPER SPACE ATTACK</b>	
SIZE	CODE IDENT NO.	DRAWING NO.	
D		726-0001	A
SCALE			SHEET 8 OF 10

726-0001

REVISIONS				
ZONE	LTR	DESCRIPTION	DATE	APPROVED
A	RELEASED		5.M. 2-19-79	<i>[Signature]</i>

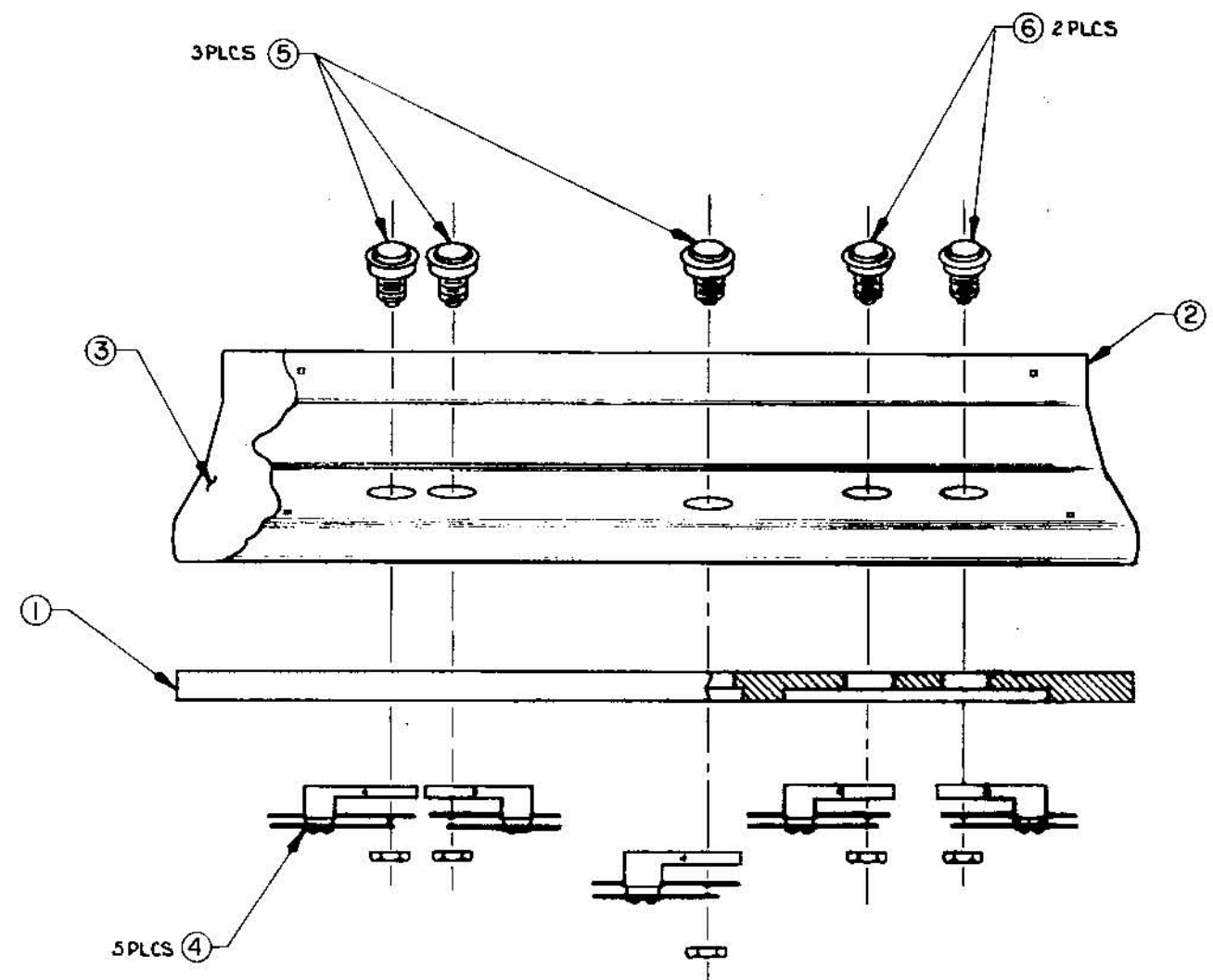

QTY REQD	CODE IDENT	PART OR IDENTIFYING NO.	NOMENCLATURE OR DESCRIPTION
PARTS LIST			
UNLESS OTHERWISE SPECIFIED DIMENSIONS ARE IN INCHES TOLERANCES ARE:		CONTRACT NO.	
FRACTIONS	DECIMALS	ANGLES	
* XX ±	XXX ±	±	
MATERIAL	FINISH	APPROVALS	DATE
		DRAWN S. MAGALIA	2-15-79
		CHECKED <i>[Signature]</i>	2-19-79
NEXT ASST USED ON APPLICATION			<b>Growth Industries, Inc.</b> San Diego, California 92108 <b>ASSEMBLY CONTROL PANEL (SPACE ATTACK)</b>
DO NOT SCALE DRAWING			SIZE CODE IDENT NO. DRAWING NO. D 826-0031 A
			SCALE 1/2 SHEET 3 OF 3

826-0031 A

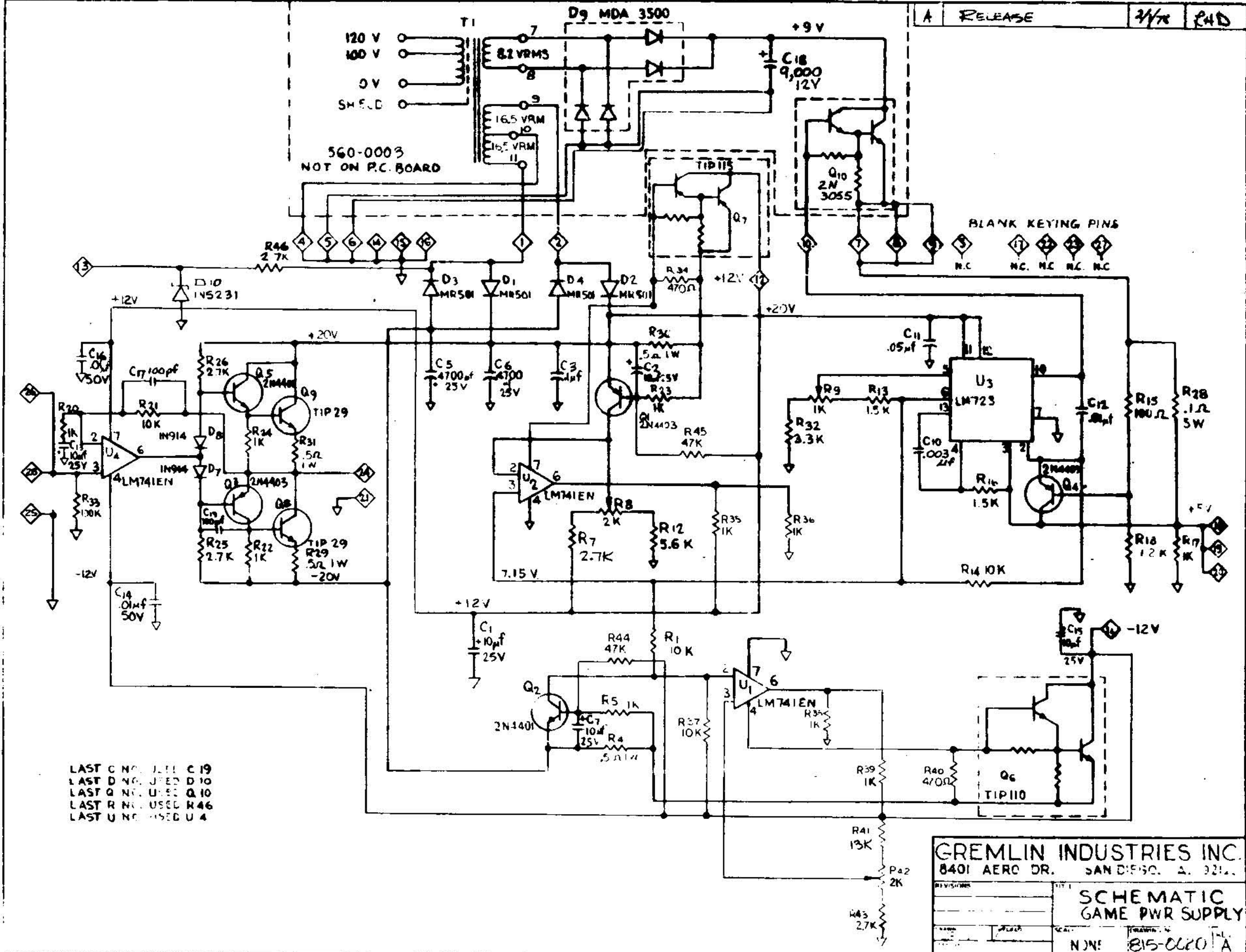

LAST C NO. USED C19  
 LAST D NO. USED D10  
 LAST Q NO. USED Q10  
 LAST R NO. USED R46  
 LAST U NO. USED U4

**GREMLIN INDUSTRIES INC.**  
 8401 AERO DR. SANDHURST, N. CAROLINA  
 REVISIONS: \_\_\_\_\_  
 DATE: \_\_\_\_\_  
 DRAWN BY: \_\_\_\_\_  
 CHECKED BY: \_\_\_\_\_  
 TITLE: **SCHEMATIC GAME PWR SUPPLY**  
 PART NO.: 815-0020/A

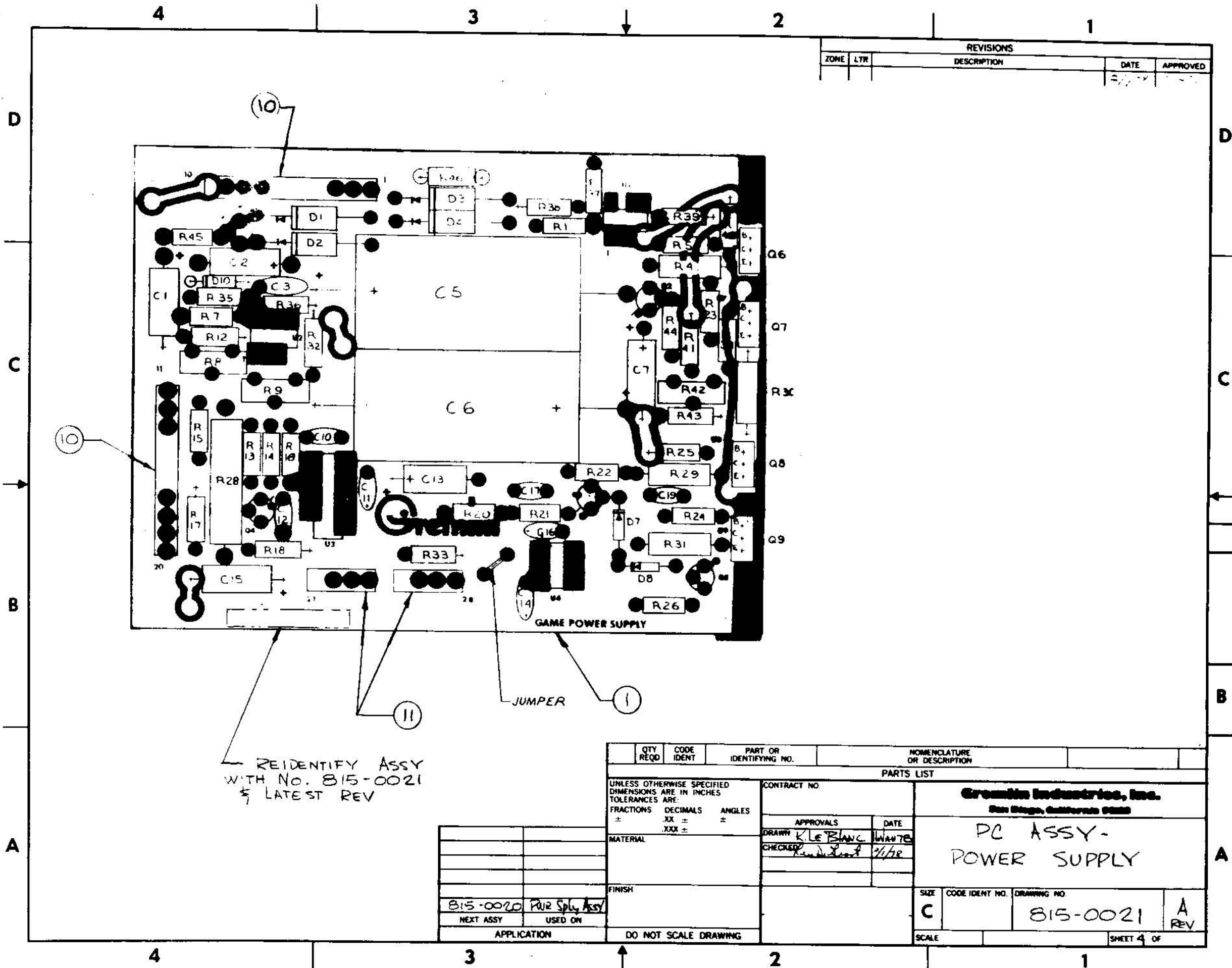

REVISIONS				
ZONE	LTR	DESCRIPTION	DATE	APPROVED

REIDENTIFY ASSY  
WITH No. 815-0021  
& LATEST REV

QTY REQD	CODE IDENT	PART OR IDENTIFYING NO.	NOMENCLATURE OR DESCRIPTION
PARTS LIST			
UNLESS OTHERWISE SPECIFIED DIMENSIONS ARE IN INCHES TOLERANCES ARE: FRACTIONS ±    DECIMALS .XX ±    ANGLES ° ±		CONTRACT NO.	
MATERIAL		APPROVALS DRAWN <i>KLEBLANC</i> DATE <i>1/14/78</i> CHECKED <i>...</i>	
FINISH		<b>Gromin Industries, Inc.</b> San Diego, California 92108	
APPLICATION		PC ASSY - POWER SUPPLY	
NEXT ASSY USED ON		SIZE <b>C</b>	CODE IDENT NO. <b>815-0021</b>
DO NOT SCALE DRAWING		DRAWING NO. <b>815-0021</b>	
		SHEET 4 OF	

815-0020	PC Power Sply Assy
----------	--------------------

REVISIONS				
REV	DATE	DESCRIPTION	BY	APP

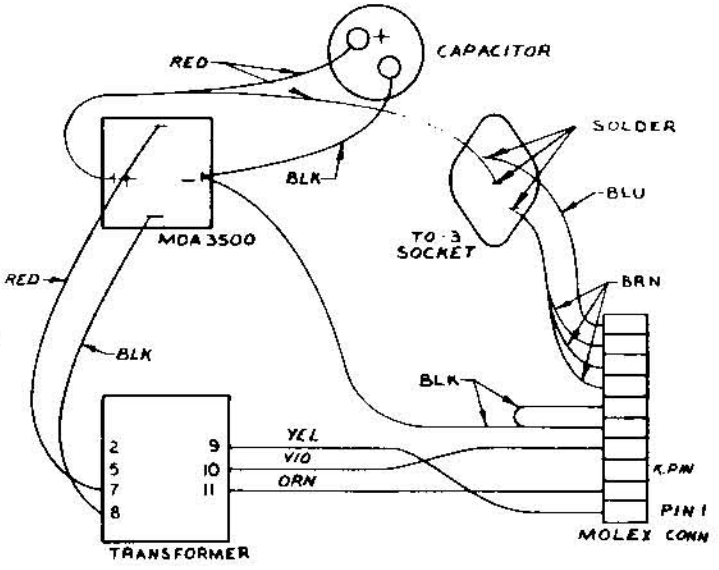
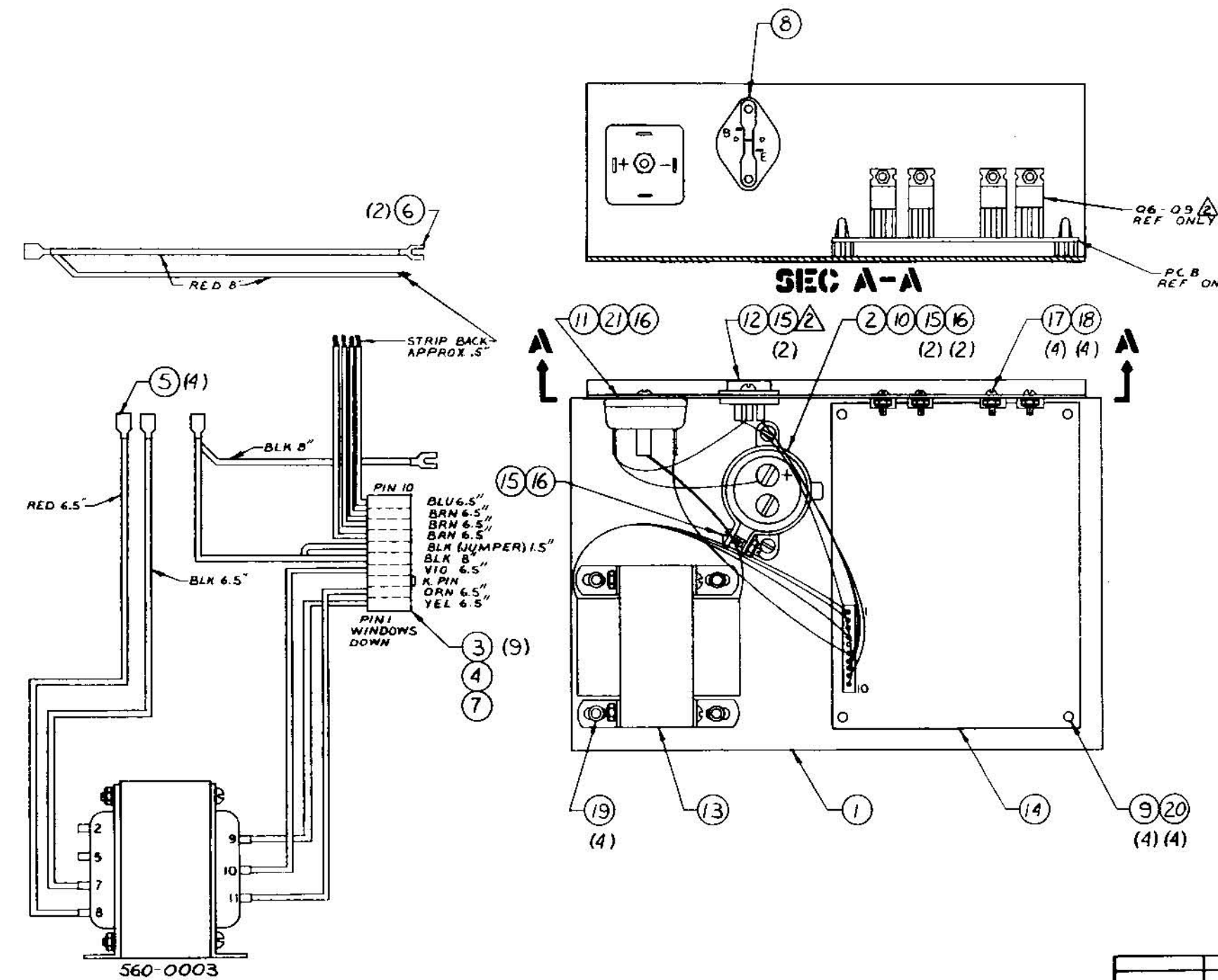

NOTES:   
 ▲ ALL POWER TRANSISTORS TO BE MOUNTED WITH HEAT SINKING PASTE & INSULATING HARDWARE   
 1 ALL WIRE TO BE AWG #22 GA   
 UNLESS OTHERWISE SPECIFIED

SEE DETACHED PARTS LIST 815-0020

QTY	REQD	CODE	PART OR IDENTIFYING NO.	NOMENCLATURE OR DESCRIPTION

UNLESS OTHERWISE SPECIFIED DIMENSIONS ARE IN INCHES TOLERANCES ARE:		CONTRACT NO.	
FRACTIONS	DIMENSIONS	APPROVALS	DATE
		PARTS LIST	
<b>Green Industries, Inc.</b> San Diego, California 92108			
<b>ASSY</b> <b>POWER SUPPLY</b>			
SIZE	CODE IDENT NO.	DRAWING NO.	REV
D		815-0020	A
SCALE FULL		SHEET 3 OF 4	

815-0020

REVISIONS				
ZONE	LTN	DESCRIPTION	DATE	APPROVED
C		REVISED & REDRAWN PER ECN 266	1-8-79	<i>[Signature]</i>
D		PER ECN 271	1-15-79	<i>[Signature]</i>
E		PER ECN 272	1-16-79	<i>[Signature]</i>
F		PER ECN 276	2-3-79	<i>[Signature]</i>

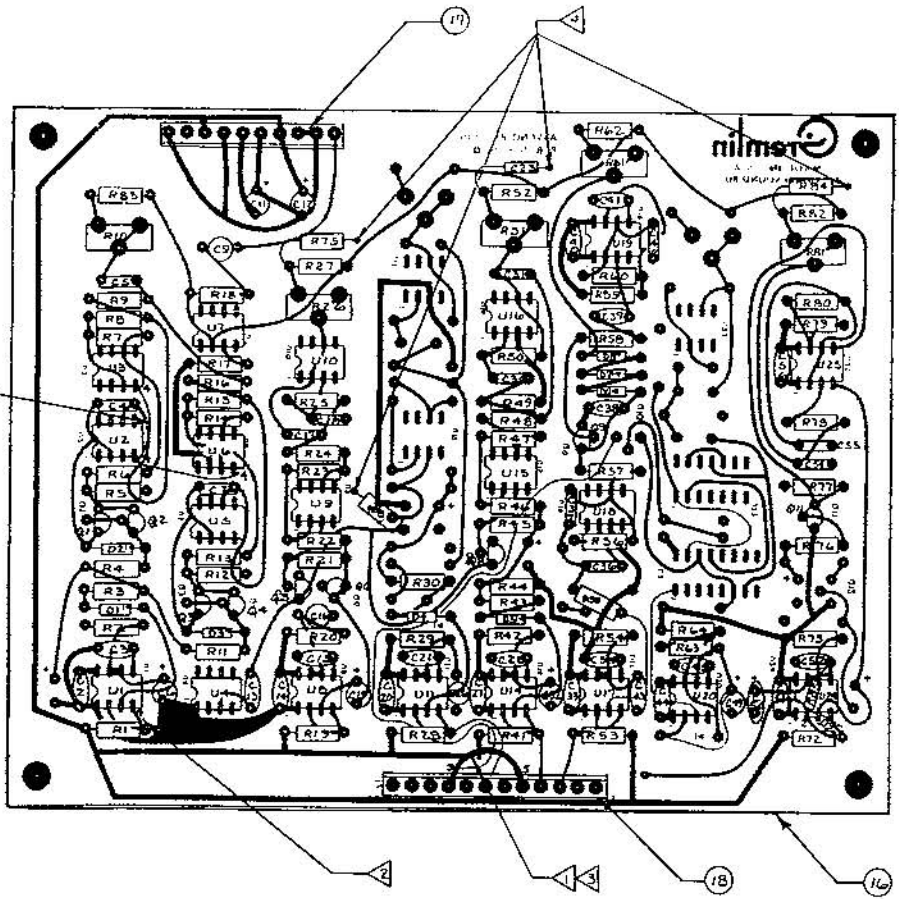

- ▽ SOLDER TO GND PLANE
- ▽ INSTALL ON BACK OF BOARD
- ▽ CUT CLAD FROM U1, PIN 4 TO H1
- ▽ JUMPER

NOTES:

SEE DETACHED PARTS LIST

QTY	CODE	PART OR IDENTIFYING NO.	NOMENCLATURE OR DESCRIPTION
PARTS LIST			
UNLESS OTHERWISE SPECIFIED DIMENSIONS ARE IN INCHES FRACTIONS ARE DECIMALS INCHES		CONTRACT NO.	<b>Growth Industries, Inc.</b> San Diego, California 92161
MATERIAL		APPROVALS	
FINISH		DATE	ASSEMBLY Y-2 SOUND BOARD
MEET ASBY USED ON		DATE	
726-0005	Y-2		REV F
726-0004	Y-2		
726-0003	Y-2		
APPLICATION		DO NOT SCALE DRAWING	REV F
		SCALE 2/1	SHEET 5 OF 6

826-0002-F

REVISIONS				
REV	DATE	DESCRIPTION	BY	APP
C	1-8-79	REVISED & REDRAWN PER ECN 266	WJB	
D	1-15-79	PER ECN 271	KB	
E	1-16-79	PER ECN 272	WJB	
F	1-31-79	PER ECN 276	KB	

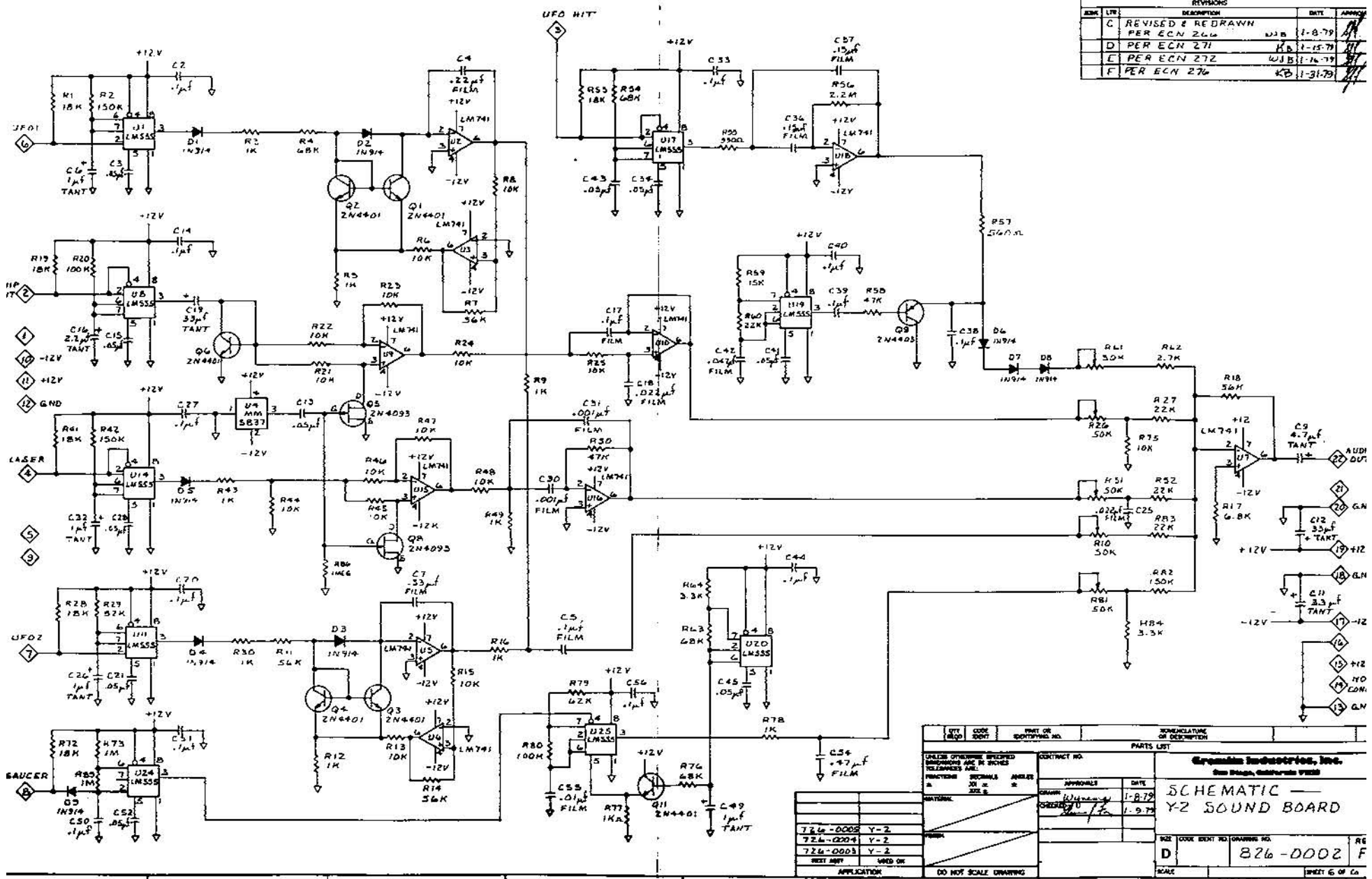

QTY	CODE	PART OR IDENTIFYING NO.	NOMENCLATURE OR DESCRIPTION
1	U1	LM741	OP AMP
1	U2	LM741	OP AMP
1	U3	LM741	OP AMP
1	U4	LM741	OP AMP
1	U5	LM741	OP AMP
1	U6	LM741	OP AMP
1	U7	LM7491	OP AMP
1	Q1	2N4401	TRANS
1	Q2	2N4401	TRANS
1	Q3	2N4401	TRANS
1	Q4	2N4401	TRANS
1	Q5	2N4401	TRANS
1	Q6	2N4401	TRANS
1	Q7	2N4401	TRANS
1	Q8	2N4401	TRANS
1	Q9	2N4401	TRANS
1	Q10	2N4401	TRANS
1	Q11	2N4401	TRANS
1	U8	LM741	OP AMP
1	U9	LM741	OP AMP
1	U10	LM741	OP AMP
1	U11	LM741	OP AMP
1	U12	LM741	OP AMP
1	U13	LM741	OP AMP
1	U14	LM741	OP AMP
1	U15	LM741	OP AMP
1	U16	LM741	OP AMP
1	U17	LM741	OP AMP
1	U18	LM741	OP AMP
1	U19	LM741	OP AMP
1	U20	LM741	OP AMP
1	U21	LM741	OP AMP
1	U22	LM741	OP AMP
1	U23	LM741	OP AMP
1	U24	LM741	OP AMP
1	U25	LM741	OP AMP
1	U26	LM741	OP AMP
1	U27	LM741	OP AMP
1	U28	LM741	OP AMP
1	U29	LM741	OP AMP
1	U30	LM741	OP AMP
1	U31	LM741	OP AMP
1	U32	LM741	OP AMP
1	U33	LM741	OP AMP
1	U34	LM741	OP AMP
1	U35	LM741	OP AMP
1	U36	LM741	OP AMP
1	U37	LM741	OP AMP
1	U38	LM741	OP AMP
1	U39	LM741	OP AMP
1	U40	LM741	OP AMP
1	U41	LM741	OP AMP
1	U42	LM741	OP AMP
1	U43	LM741	OP AMP
1	U44	LM741	OP AMP
1	U45	LM741	OP AMP
1	U46	LM741	OP AMP
1	U47	LM741	OP AMP
1	U48	LM741	OP AMP
1	U49	LM741	OP AMP
1	U50	LM741	OP AMP
1	U51	LM741	OP AMP
1	U52	LM741	OP AMP
1	U53	LM741	OP AMP
1	U54	LM741	OP AMP
1	U55	LM741	OP AMP
1	U56	LM741	OP AMP
1	U57	LM741	OP AMP
1	U58	LM741	OP AMP
1	U59	LM741	OP AMP
1	U60	LM741	OP AMP
1	U61	LM741	OP AMP
1	U62	LM741	OP AMP
1	U63	LM741	OP AMP
1	U64	LM741	OP AMP
1	U65	LM741	OP AMP
1	U66	LM741	OP AMP
1	U67	LM741	OP AMP
1	U68	LM741	OP AMP
1	U69	LM741	OP AMP
1	U70	LM741	OP AMP
1	U71	LM741	OP AMP
1	U72	LM741	OP AMP
1	U73	LM741	OP AMP
1	U74	LM741	OP AMP
1	U75	LM741	OP AMP
1	U76	LM741	OP AMP
1	U77	LM741	OP AMP
1	U78	LM741	OP AMP
1	U79	LM741	OP AMP
1	U80	LM741	OP AMP
1	U81	LM741	OP AMP
1	U82	LM741	OP AMP
1	U83	LM741	OP AMP
1	U84	LM741	OP AMP
1	U85	LM741	OP AMP
1	U86	LM741	OP AMP
1	U87	LM741	OP AMP
1	U88	LM741	OP AMP
1	U89	LM741	OP AMP
1	U90	LM741	OP AMP
1	U91	LM741	OP AMP
1	U92	LM741	OP AMP
1	U93	LM741	OP AMP
1	U94	LM741	OP AMP
1	U95	LM741	OP AMP
1	U96	LM741	OP AMP
1	U97	LM741	OP AMP
1	U98	LM741	OP AMP
1	U99	LM741	OP AMP
1	U100	LM741	OP AMP

**SCHEMATIC**  
**Y-2 SOUND BOARD**

826-0002 F



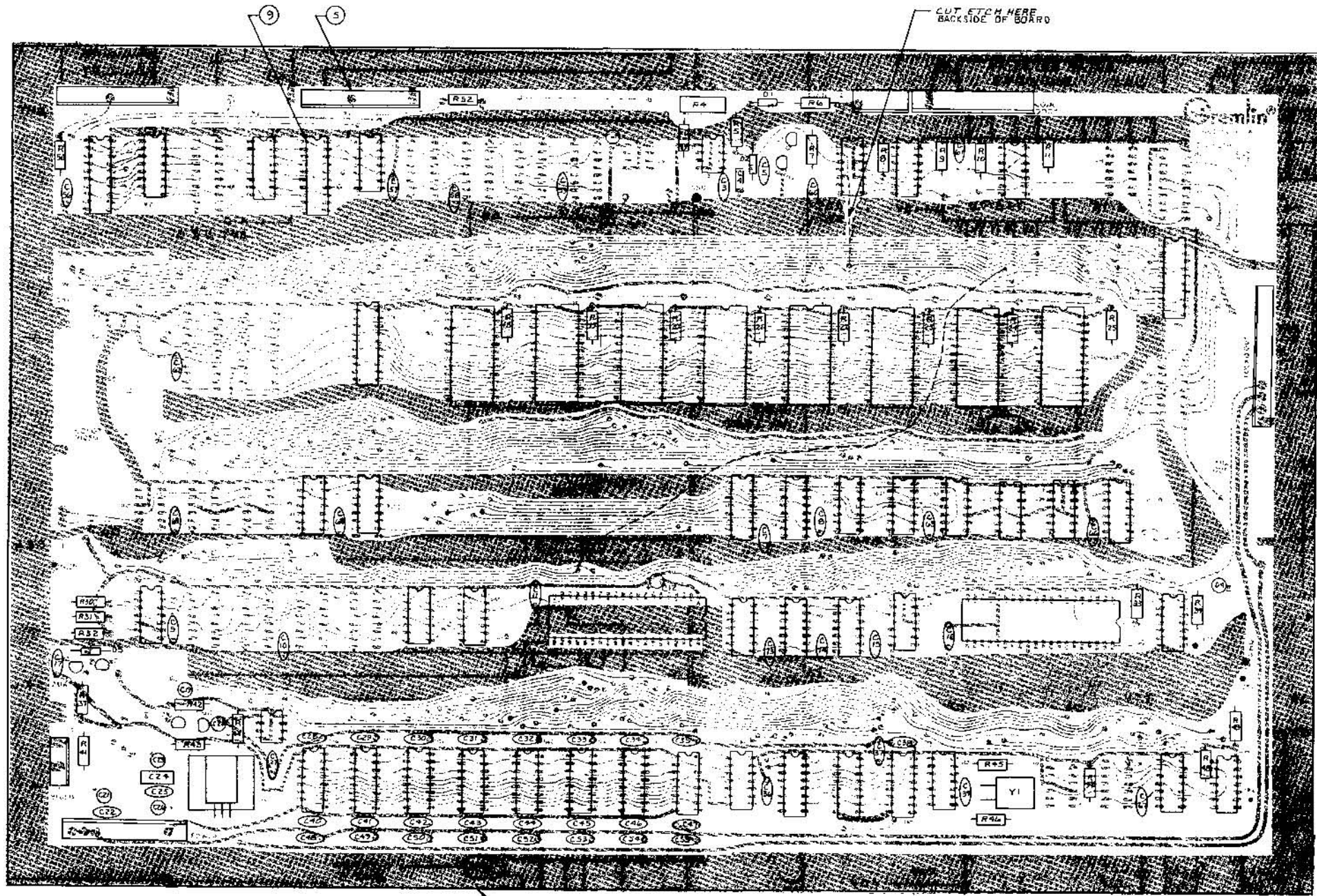

SEE DETACHED PARTS LIST

REV	DATE	DESCRIPTION
1	1-18-77	ASSEMBLY
2	1-18-77	SPACE ATTACK
3	1-18-77	C.V. LOGIC

726-0004	REV A
726-0004	REV A

3	2	1
---	---	---

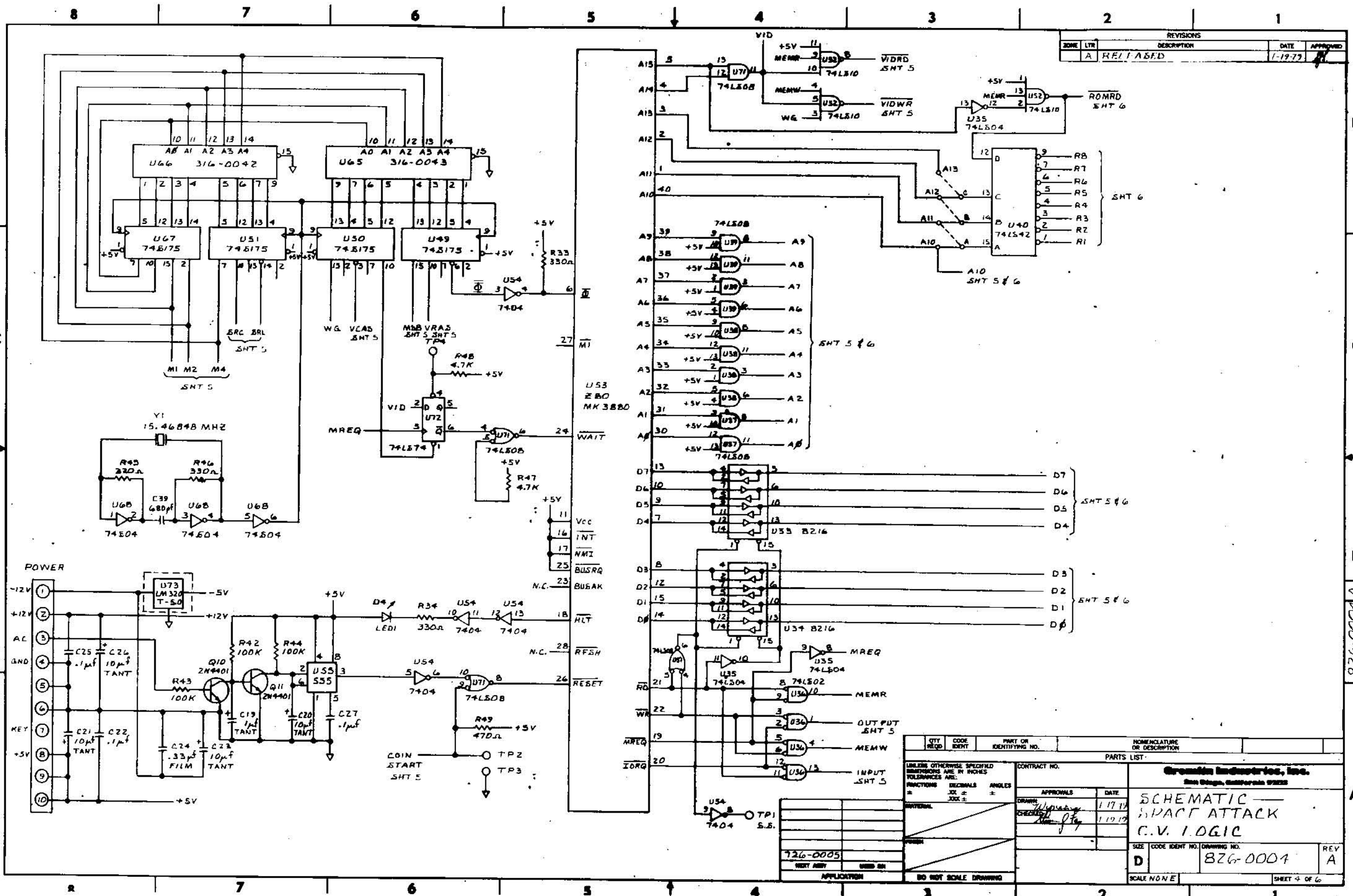

REVISIONS				
ZONE	LTR	DESCRIPTION	DATE	APPROVED
A	REL	ASFD	1-19-77	[Signature]

QTY	CODE	PART OR IDENTIFYING NO.	NOMENCLATURE OR DESCRIPTION
			U55 555
			U49 74LS175
			U52 74LS175
			U51 74LS175
			U50 74LS175
			U48 74LS175
			U68 74LS04
			U72 74LS174
			U40 74LS42
			U35 74LS04
			U33 74LS10
			U32 74LS10
			U31 74LS10
			U30 74LS10
			U29 74LS10
			U28 74LS10
			U27 74LS10
			U26 74LS10
			U25 74LS10
			U24 74LS10
			U23 74LS10
			U22 74LS10
			U21 74LS10
			U20 74LS10
			U19 74LS10
			U18 74LS10
			U17 74LS10
			U16 74LS10
			U15 74LS10
			U14 74LS10
			U13 74LS10
			U12 74LS10
			U11 74LS10
			U10 74LS10
			U9 74LS10
			U8 74LS10
			U7 74LS10
			U6 74LS10
			U5 74LS10
			U4 74LS10
			U3 74LS10
			U2 74LS10
			U1 74LS10

826-0004A

**Creskold Industries, Inc.**  
San Diego, California 92122

**SCHEMATIC — SPACE ATTACK**  
C.V. LOGIC

SIZE CODE IDENT NO. DRAWING NO. REV  
D 826-0004 A

726-0005	ISSUED BY
	APPLICATION

DO NOT SCALE DRAWING

SCALE NONE SHEET 4 OF 6

REVISIONS				
ZONE	LTR	DESCRIPTION	DATE	APPROVED
A		RELEASED	1-17-79	

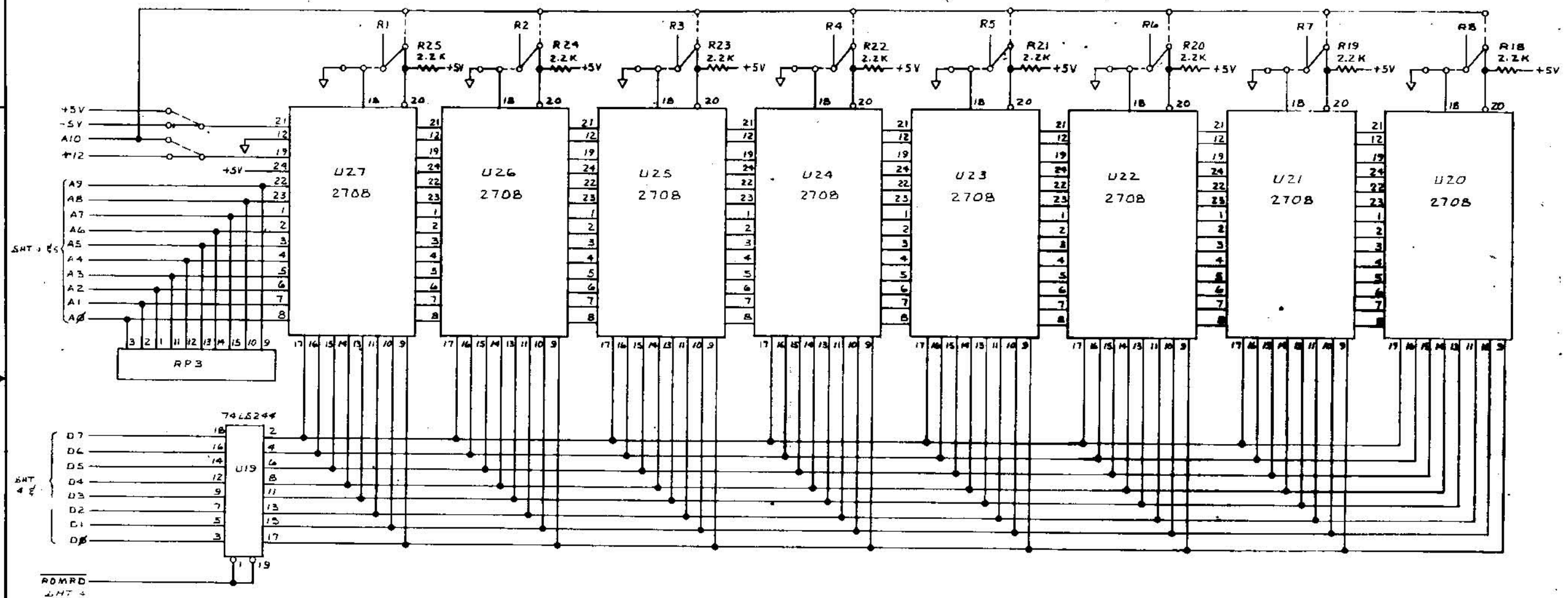

826-0004 A

QTY. REQD.	CODE IDENT.	PART OR IDENTIFYING NO.	NOMENCLATURE OR DESCRIPTION
PARTS LIST			<b>Granite Industries, Inc.</b> San Diego, California 92108
UNLESS OTHERWISE SPECIFIED DIMENSIONS ARE IN INCHES TOLERANCES ARE: FRACTIONS DECIMALS ANGLES		CONTRACT NO.	DATE
APPROVALS		DATE	DATE
DESIGNED BY		DATE	DATE
CHECKED BY		DATE	DATE
DRAWN BY		DATE	DATE
MATERIAL		DATE	DATE
FINISH		DATE	DATE
826-0005		826-0004	826-0004
USED ON		826-0004	826-0004
APPLICATION		826-0004	826-0004
DO NOT SCALE DRAWING		SCALE NONE	SHEET 6 OF 6

**SCHEMATIC —  
SPACE ATTACK  
C.V. LOGIC**

826-0004 A

REVISIONS				
ZONE	LTR	DESCRIPTION	DATE	APPROVED
1		RELEASE		

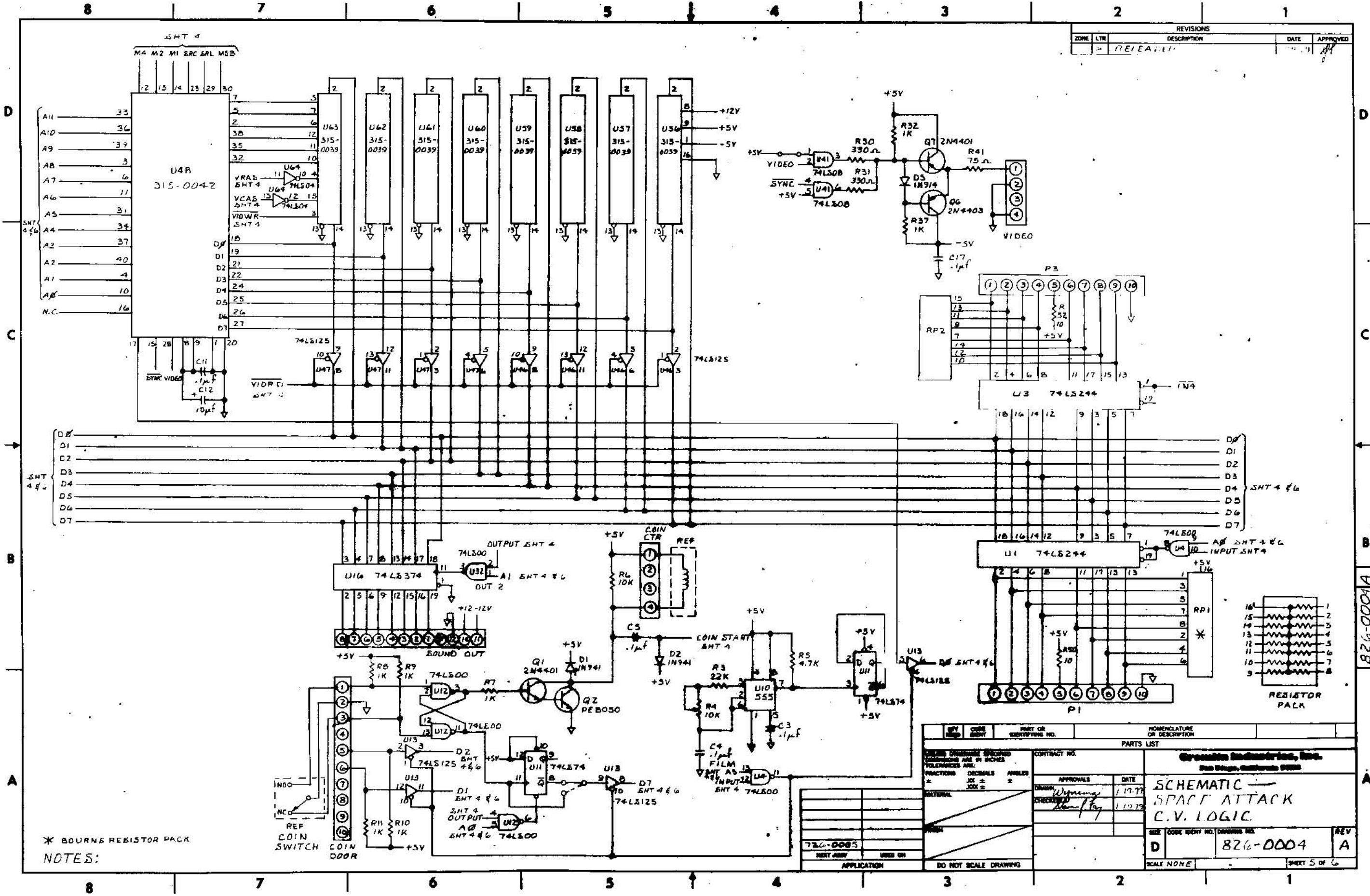

\* BOURNS RESISTOR PACK  
NOTES:

APPROVALS		DATE
DESIGNED	W. [Signature]	1/19/77
CHECKED	[Signature]	1/19/77

**SCHEMATIC  
SPACE ATTACK  
C.V. LOGIC**

SEE CODE IDENT. NO. DRAWING NO. **826-0004** REV **A**

SCALE NONE SHEET 5 OF 6