

SPY HUNTER

Parts and Operating Manual

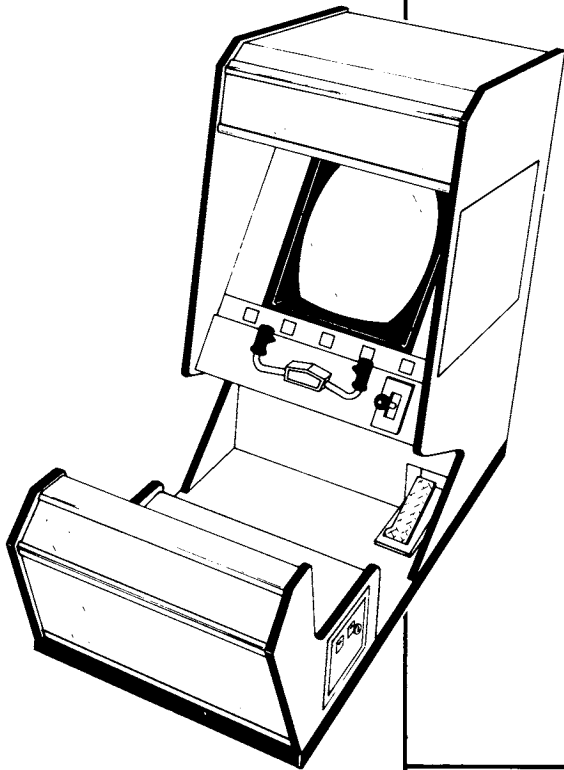

NO. 307
SIT DOWN

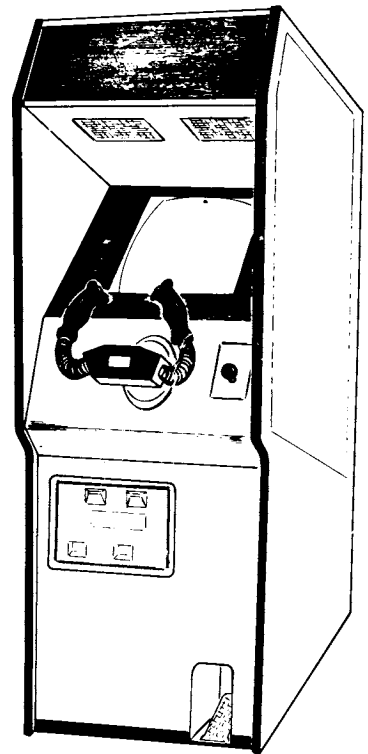

NO. A27
UPRIGHT

Bally

MIDWAY MFG. CO.

10601 W. Belmont Avenue
Franklin Park, Illinois 60131
U.S.A.



Phone: (312) 451-9200 Cable Address: MIDCO Telex No.: 72-1596

SPY HUNTER

TABLE OF CONTENTS

DESCRIPTION	PAGE
GAME OPERATION.....	1
SCORING POINT VALUES.....	2
OPTION SWITCH SETTINGS.....	3
 ILLUSTRATED PARTS BREAKDOWN	
SPY HUNTER SIT DOWN - FRONT.....	4
SPY HUNTER SIT DOWN - FRONT PARTS LIST.....	5-6
FLUORESCENT HEADER FIXTURE ASSY. & PARTS LIST.....	7
GEAR SHIFT ASSY. (UPRIGHT & SIT DOWN).....	8
GEAR SHIFT ASSY. (UPRIGHT & SIT DOWN) - PARTS LIST.....	9
ACCELERATOR PEDAL ASSEMBLY (SIT DOWN).....	10
ACCELERATOR PEDAL ASSEMBLY (SIT DOWN) - PARTS LIST.....	11
STEERING CONTROL ASSY. (UPRIGHT & SIT DOWN).....	12
STEERING CONTROL ASSY. (UPRIGHT & SIT DOWN) PARTS LIST.....	13
POWER CHASSIS ASSY. - 125VA, 115V.....	14
POWER CHASSIS ASSY. - 125VA, 115V - PARTS LIST.....	15
FRONT DOOR ASSY.....	16
FRONT DOOR ASSY - PARTS LIST.....	17
 SPY HUNTER <u>UPRIGHT NON-INTERCHANGEABLE</u> PARTS LISTS	
SPY HUNTER UPRIGHT - FRONT.....	1
SPY HUNTER UPRIGHT - FRONT PARTS LIST.....	2-3
ACCELERATOR PEDAL ASSEMBLY (UPRIGHT).....	4
ACCELERATOR PEDAL ASSEMBLY (UPRIGHT) - PARTS LIST.....	5
 SCHEMATICS & WIRING DIAGRAM	
WIRING DIAGRAM.....	1
VIDEO GENERATOR MCR III P.C. - COMPONENT LAYOUT.....	2
VIDEO GENERATOR MCR III P.C. - SCHEMATIC.....	3
SUPER SOUND I/O P.C. - COMPONENT LAYOUT.....	4
SUPER SOUND I/O P.C. - SCHEMATIC.....	5
CHEAP SQUEAK DELUXE - COMPONENT LAYOUT.....	6
CHEAP SQUEAK DELUXE - SCHEMATIC.....	7
SOUND I/O P.C. W/PANNING (SIT DOWN ONLY) - COMPONENT LAYOUT.....	8
SOUND I/O P.C. W/PANNING (SIT DOWN ONLY) - SCHEMATIC.....	9
LAMP DRIVER P.C. - COMPONENT LAYOUT.....	10
LAMP DRIVER P.C. - SCHEMATIC.....	11
ABSOLUTE POSITION P.C. - COMPONENT LAYOUT.....	12
ABSOLUTE POSITION P.C. - SCHEMATIC.....	13
CPU MCR III P.C. - COMPONENT LAYOUT.....	14
CPU MCR III P.C. - SCHEMATIC.....	15

SPY HUNTER

GAME OPERATION

ATTRACT MODE

1. The Attract mode starts:
 - Just after power has been turned on to the game. (Self-Test switch is in the "OFF" position.)
 - After a Self-Test has been completed and there are no more credits left in the games memory.
 - After a play has been finished, the score was not high enough to put the game into the High Score/Initial mode, and there are no more credits left in the games memory.
 - After the High Score/Initial mode when there are no more credits left in its memory.
 - No matter where the game is in the Attract mode sequence, it will immediately go to the Ready-To-Play mode display as soon as a game has been paid for.

READY-TO-PLAY MODE

1. The Ready-To-Play mode starts when enough coins have been accepted for a 1 player game.
2. The Ready-To-Play mode ends when the "WEAPONS VAN" push button is pressed (it also serves as a "START" button).

PLAY MODE

1. The Play mode begins when the "WEAPONS VAN" push button is pressed (it also serves as a "START" button).
2. The Play mode ends when all of your CARS have been eliminated. When this happens, "GAME OVER" is written across the monitor screen.

HIGH SCORE/INITIAL MODE:

If your score was high enough to become one of the ten best scores, the game will go into the High Score/Initial mode immediately after the "GAME OVER" display. If your score is not high enough to cause the game to go into the High Score/Initial mode, it will either go to the Attract mode (if there are no more credits left in its memory) or into the Ready-To-Play mode (if there are still credits left in its memory).

Follow the ON-SCREEN instructions to enter your initials next to your score in the league of the best ten players to date.

After the High Score/Initial mode, the game will either go to the Attract mode (if there are no more credits left in its memory) or into the Ready-To-Play mode (if there are still credits left in its memory).

SPY HUNTER

SCORING

DESCRIPTION	POINTS AWARDED	NOTES
BUMPER CAR	150 POINTS	ON THE ROAD
TIRE SLASHER	150 POINTS	ON THE ROAD
LIMO	500 POINTS	ON THE ROAD
SPEED BOAT	150 POINTS	IN THE WATER
TORPEDO BOAT	500 POINTS	IN THE WATER
HELICOPTER	700 POINTS	ROAD & WATER
STAYING ON ROAD	15 POINTS	FOR EACH 1/4 SCREEN TRAVELED
STAYING IN WATER	25 POINTS	FOR EACH 1/4 SCREEN TRAVELED

SPY HUNTER

OPTION SWITCH SETTINGS

////////////////////////////////////SWITCH NO. 1 - AT B 3 - LOCATED ON SOUND I/O P.C. BOARD////////////////////////////////////

DURING GAME PLAY:

SW#1	SW#2	SW#3	SW#4	SW#5	SW#6	SW#7	SW#8	SW#9	SW#10
NOT	NOT	NOT	NOT	NOT	NOT	NOT	NOT	NOT	NOT
USED	USED	USED	USED	USED	USED	USED	USED	USED	USED

FREEZE VIDEO
**NORMAL OPERATION

ON
OFF

////////////////////////////////////SWITCH NO. 3 - AT D 14 - LOCATED ON SOUND I/O P.C. BOARD////////////////////////////////////

**NORMAL OPERATION	SW#1	*SW#2	*SW#3	*SW#4
SOUND I/O DIAGNOSTIC MODE	OFF			
	ON			

**NORMAL OPERATION
RAM/ROM TEST
INDICATES TEST RESULTS VIA
YELLOW L E D ON SOUND I/O
BOARD:
FAST FLASH = BAD ROM
SLOW FLASH = BAD RAM

OFF
ON

**NORMAL OPERATION
OSCILLATOR TEST

OFF
ON

**NORMAL OPERATION
FILTER TEST

OFF
ON

*NO EFFECT IF SW#1 OF SWITCH NO. 3 IS IN THE "OFF" POSITION.
**FACTORY RECOMMENDED SETTINGS.

PART NO. M051-00307-A007

THE REMAINDER OF YOUR NEW GAME'S MOST COMMON OPTION SETTINGS ARE CONDUCTED DURING
THE MACHINE SETUP PORTION OF THE SELF-TEST MODE.

SPY HUNTER UPRIGHT PARTS LIST

THAT ARE NOT INTERCHANGEABLE
WITH THE SIT DOWN MODEL

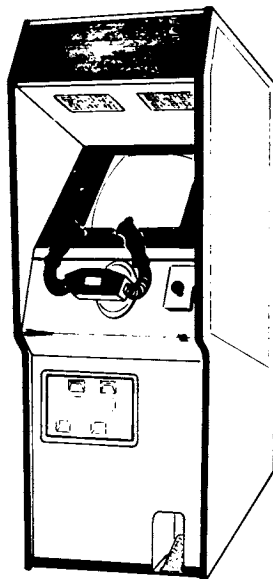

Bally

MIDWAY MFG. CO.

10601 W. Belmont Avenue
Franklin Park, Illinois 60131
U.S.A.



Phone: (312) 451-9200 Cable Address: MIDCO Telex No.: 72-1596

M051-00A27-A043

NO. 0A27 - SPY HUNTER UPRIGHT - FRONT

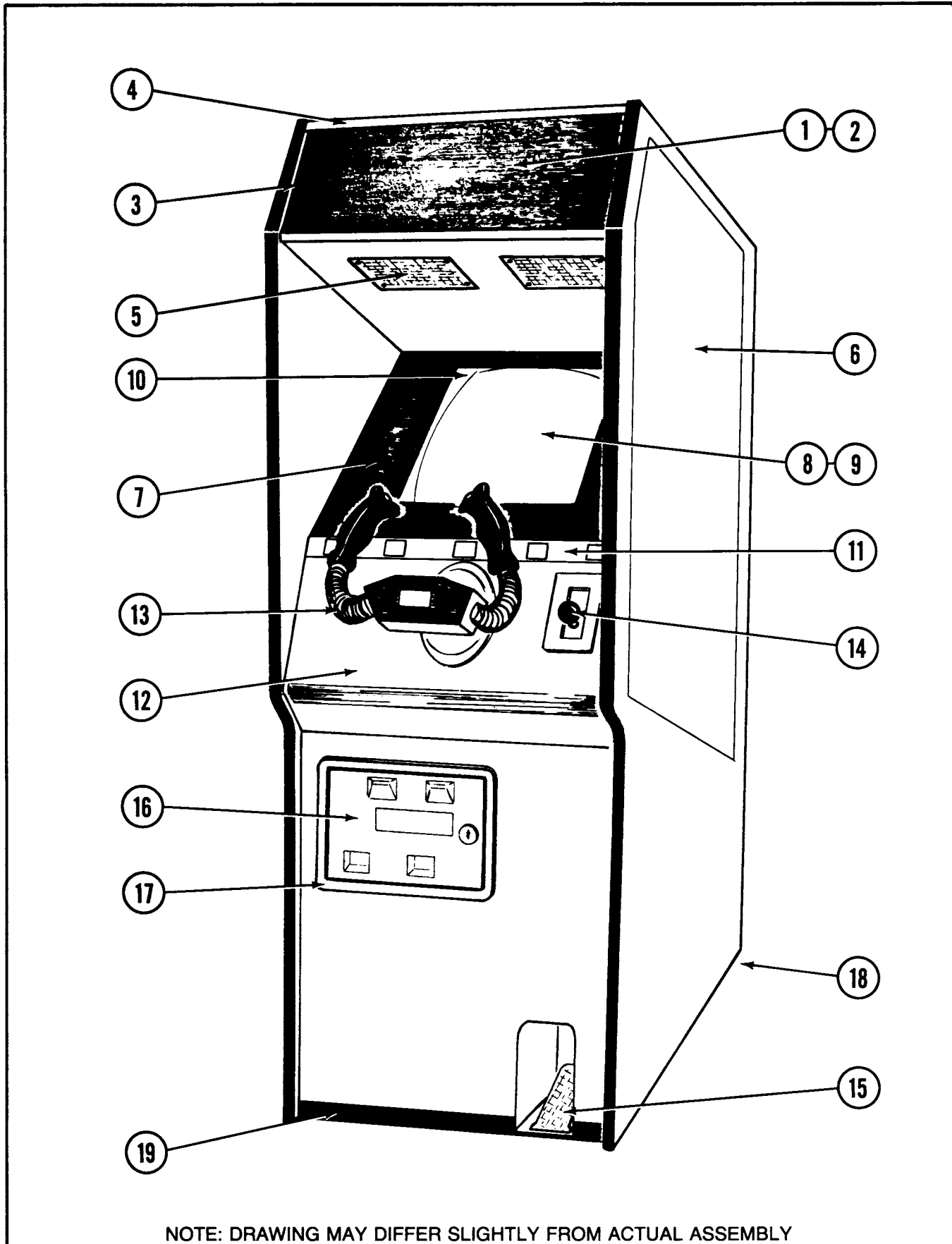

NOTE: DRAWING MAY DIFFER SLIGHTLY FROM ACTUAL ASSEMBLY

NO. 0A27 - SPY HUNTER UPRIGHT - FRONT PARTS LIST

ORDER BY PART NUMBER ONLY

ITEM	PART NO.	DESCRIPTION
1	0A27-00900-00XF	HEADER GLASS
2*	A595-00011-0000	HEADER LIGHT ASSY.
3	0537-00903-0052	GLASS CHANNEL - 8-1/2" LG (2 REQ'D)
4	0574-00903-0100	HEADER RETAINER BRKT. (2 REQ'D)
	0017-00101-0138	#8x5/8 TORX TAMPER PROOF SCREW (10 REQ'D)
	0017-00009-0522	LONG ARM KEY T-20 (FOR ABOVE SCREW)
5	0017-00003-0430	6"x9" SPEAKER - 4 OHM, 10W. (2 REQ'D)
	Q130-00002-0000	SPEAKER COVER (2 REQ'D)
	0017-00101-0127	#8-32x1-1/2" CARRIAGE BOLT (8 REQ'D)
	0017-00103-0061	#8-32 HEX NUT W/SEMS (8 REQ'D)
6	0A27-00903-0000	DECAL (2 REQ'D)
7	0A27-00901-00XF	MAIN VIEWING GLASS
8	Q200-00019-0000	19" COLOR VERTICAL MONITOR
	A353-00023-0000	VERTICAL MONITOR MTG. BRKT. ASSY. (2 REQ'D)
	0555-00901-0000	PLASTIC LOCATING PIN (4 REQ'D)
	0017-00101-0141	#8x11/16 UNSLOT HEX HD. M.S. (8 REQ'D)
9	0314-00902-0000	PLEXI-GLASS
	0508-00901-0000	PLEXI-GLASS MTG PLATE
	0017-00101-0017	#6x1/2 BLACK SLT. HEX HD. SCR. (4 REQ'D)
10	0307-00918-0000	T.V. BEZEL
	0508-00106-0000	BEZEL MTG. BRKT.
11	A307-00044-0000	LIGHT PANEL ASSY.
	0360-00935-0000	SMALL SHADOW BOX (5 REQ'D)
	0017-00003-0219	#194 WEDGE BASE LAMP -14V., .27A. (5 REQ'D)
	0017-00031-0030	WEDGE BASE LAMP SOCKET (5 REQ'D)
12	AA27-00014-0000	CONTROL PLATE & WELD STUDS ASSY.
	0307-00911-0000	DECORATIVE OVERLAY
	0307-00132-0100	CONTROL SHELF MTG. BRKT. - RIGHT
	0307-00132-0200	CONTROL SHELF MTG. BRKT. - LEFT
	0555-00901-0000	PLASTIC LOCATING PINS (4 REQ'D)
	0017-00009-0534	BASSICK CLAMP (2 REQ'D)
	0610-00132-00ZN	STRIKE (2 REQ'D)
	0017-00101-0141	#8x11/16 UNSLOT. HEX HD. SCREW (12 REQ'D)
	0307-00117-00XF	CONTROL SHELF HINGE
	A307-00005-0000	CONTROL SHELF CABLE ASSY.
13*	A307-00042-0000	CONTROL HANDLE ASSY.
14*	A307-00038-0000	GEAR SHIFT ASSY.
15	AA27-00018-0000	ACCELERATOR PEDAL ASSY.
	0A27-00105-00XF	ACCELERATOR BASE (FLOOR PLATE)
	0A27-00104-00XF	ACCELERATOR BOX COVER (WALL PLATE)
16	A982-00014-0000	COIN DOOR & CABLE ASSY. - U.S.A. 25¢
	A950-00004-0000	COIN BOX COVER
	A950-00006-0100	WIRE COIN BOX CRADLE ASSY.
	0950-00105-0000	COIN BOX COVER
	0950-00104-0000	COIN BOX HANDLE
	0950-00101-0000	COIN DEFLECTOR (2 REQ'D)
	0950-00900-0000	LARGE PLASTIC COIN BOX
	0950-00103-0000	COIN BOX DIVIDER - OPTIONAL

*SEE SIT DOWN CATALOG FOR ILLUSTRATED PARTS BREAK DOWN

NO. 0A27 - SPY HUNTER UPRIGHT - FRONT PARTS LIST

ORDER BY PART NUMBER ONLY

ITEM	PART NO.	DESCRIPTION
16	0017-00101-0142	1/4-20x1-3/8 BLACK RND. HD. BOLT (4 REQ'D)
	0017-00104-0014	7/8" DISH WASHER (4 REQ'D)
	0017-00103-0000	1/4-20 HEX NUT (4 REQ'D)
17	0090-00002-04BK	LARGE COIN DOOR FRAME
	0017-00101-0121	#6-32x5/16 PHIL. TRS. HD. SCR. (3 REQ'D)
18	0017-00102-0048	3/8-16x2" LEG LEVELERS (4 REQ'D)
	0017-00103-0026	3/8-16 LEG LEVELER HEX NUTS (4 REQ'D)
19	0A27-00108-00XF	BOTTOM TRIM PLATE
	0017-00101-0138	#8x5/8 TORX TAMPER PROOF SCREW (5 REQ'D)
	0017-00101-0179	#10-32x3/8 TORX PHIL. PAN HD. SCREW (2 REQ'D)
ADDITIONAL PARTS LIST		
	AA27-00012-0000	CARD RACK SUPPORT BRKT. ASSY.
	AA27-00007-0000	CARD RACK ASSY. W/BOARDS
	A084-90913-AA27	SOUND I/O P.C. BOARD ASSY.
	A307-00025-0000	SHIELD & BARRIER ASSY.
	0017-00101-0339	#6-32x3/8 PHIL. RND. SCREW (4 REQ'D)
	A084-91442-AA27	C.P.U. MCR-3 P.C. BRD. ASSY.
	A307-00026-0000	SHIELD ASSY. - INNER
	A084-91433-AA27	VIDEO GEN. MCR-3 P.C. BRD. ASSY.
	A307-00027-0000	SHIELD ASSY. - OUTER
	0017-00101-0153	#6-31x1" PHIL. RND. HD. SCREW (8 REQ'D)
	A088-00016-0000	INTERLOCK SWITCH & SPRING BRKT. ASSY.
	0303-00904-0000	INTERLOCK SWITCH COVER
	A945-00038-0000	ON-OFF SWITCH & PLATE ASSY.
	A307-00034-0000	MULTIFUNCTION SWITCH/BRKT. ASSY.
*	A945-00020-0000	POWER CHASSIS ASSY. -125VA., 115V
	A945-00019-0000	LINE CORD ASSY. -115V
	A084-91648-A000	DUAL POWER AMP W/MIXER ASSY.
	A307-00047-0000	ABSOLUTE POSITION BRD. W/SPACER ASSY.
	A307-00048-0000	LAMP DIVER P.C.B. W/ SPACER ASSY.
	A307-00049-0000	CHEAP SQUEAK & SPACER P.C. ASSY.
	A084-90412-D000	POWER SUPPLY -125VA
	0624-00902-0100	P.C. SUPPORT BRKT. - 12" LG. (2 REQ'D)
	0624-00902-0500	P.C. SUPPORT BRKT. - 6-1/2" LG. (2 REQ'D)
	0017-00101-0141	#8x11/16 UNSLOT HEX HD. SCREW (10 REQ'D)
	0017-00104-0037	#8 FLAT WASHER (10 REQ'D)
	0894-00916-0000	PLASTIC PULL & VENT (2 REQ'D)
	0017-00101-0141	#8x11/16 UNSLOT HEX HD. SCREW (8 REQ'D)
	A961-00007-0000	CASTER ASSY.
	0017-00005-0201	BACK DOOR LOCK & KEY
	0017-00009-0490	5-5/8" SQR. VENT GRILLE (4 REQ'D)

*SEE SIT DOWN CATALOG FOR ILLUSTRATED PARTS BREAK DOWN

NO. 0A27 - SPY HUNTER UPRIGHT - ACCELERATOR PEDAL ASSY.

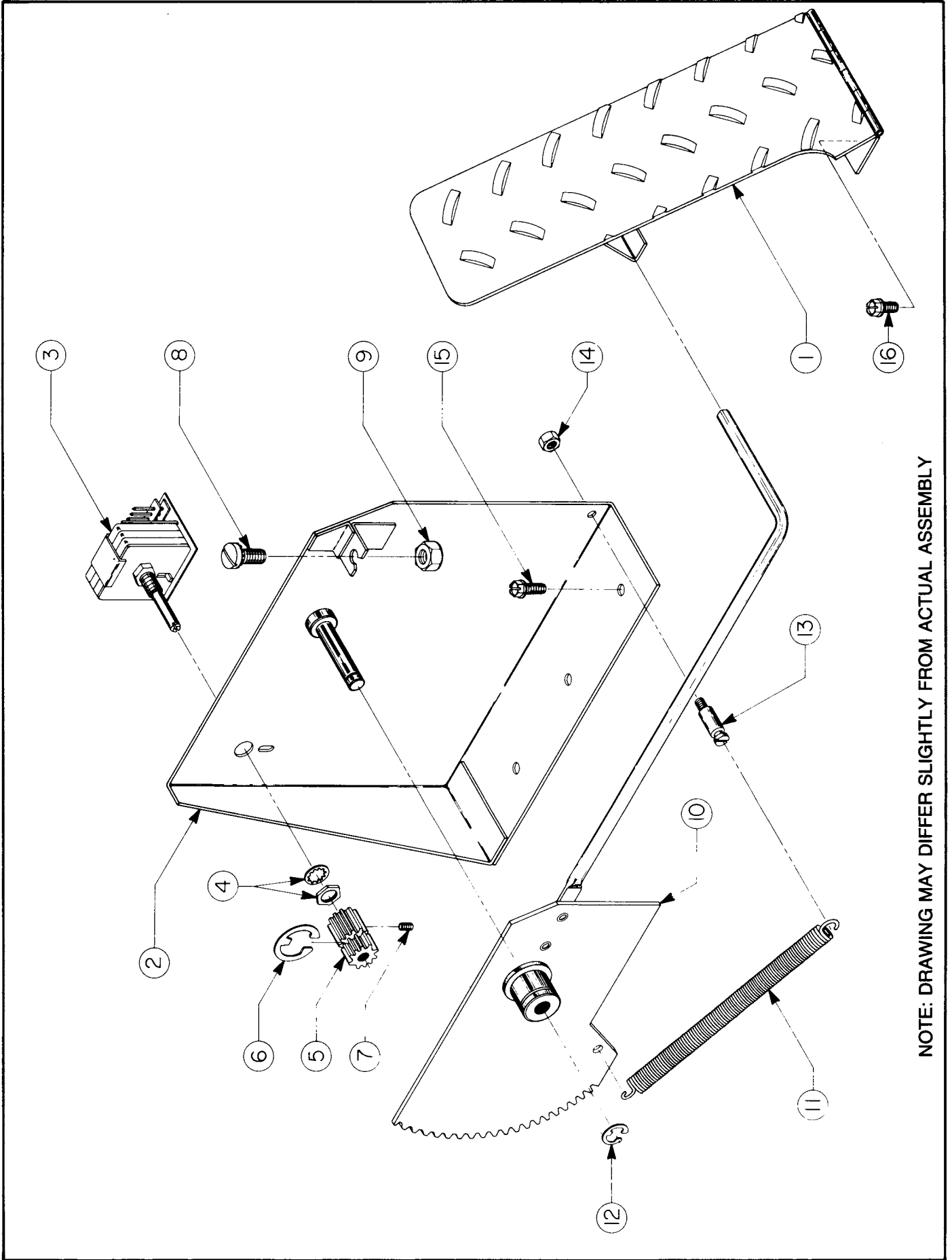

NOTE: DRAWING MAY DIFFER SLIGHTLY FROM ACTUAL ASSEMBLY

NO. 0A27 - SPY HUNTER UPRIGHT - ACCELERATOR PEDAL ASSY. - PARTS LIST

ORDER BY PART NUMBER ONLY

ITEM	PART NO.	DESCRIPTION
1	AA27-00019-0000	ACCELERATOR PEDAL & HINGE ASSY.
2	AA27-00015-0000	STUD & ACCEL. STOP BRKT. ASSY.
3	105E-00004-0002	POT
4		NOT USED
5	0A27-00701-00XF	GEAR - 16/32
	AA27-00017-0000	POT & GEAR ASSY. (ITEMS 3 & 5)
6	0017-00100-0031	5/16" E-RING
7		NOT USED
8	0017-00102-0002	1/4-20x1/2 SLT. HEX HD. M.S.
9	0653-00734-0000	STOP - POT LIMIT
10	AA27-00016-0000	ACCELERATOR LEVER & GEAR ASSY.
11	0010-00280-0000	ACCEL. PEDAL SPRING
12	0017-00100-0122	1/4" E-RING
13	0307-00703-00XF	PIVOT POST
14	0017-00103-0081	#10-32 HEX NUT W/SEMS
15 & 16	0017-00101-0598	#8-32x5/16 SLT.HEX HD. M.S. (11 REQ'D)
ADDITIONAL PARTS LIST		
	0A27-00105-00XF	ACCELERATOR BASE (FLOOR PLATE)
	0A27-00104-00XF	ACCELERATOR BOX COVER (WALL PLATE)
	0A27-00107-00XF	ACCELERATOR LEVER STOP PLATE
	0921-00700-0000	PLASTIC ACTUATOR (GEAR & LEVER ASSY. - SHAFT)

NO. 307 - SPY HUNTER SIT DOWN - FRONT

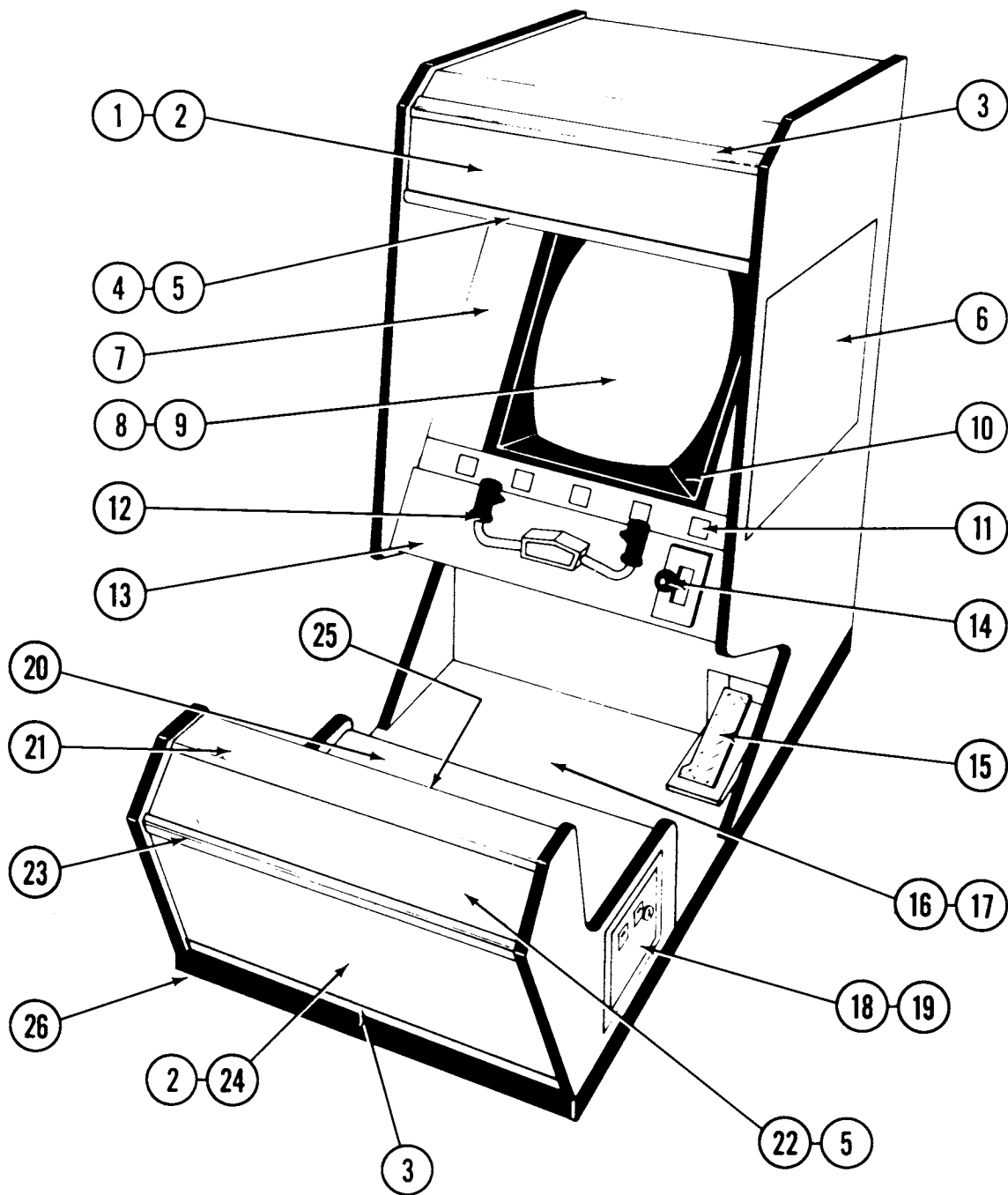

NOTE: DRAWING MAY DIFFER SLIGHTLY FROM ACTUAL ASSEMBLY

NO. 307 - SPY HUNTER SIT DOWN - FRONT PARTS LIST

ORDER BY PART NUMBER ONLY

ITEM	PART NO.	DESCRIPTION
1	0307-00902-00XF	HEADER GLASS - MAIN
2	A595-00011-0000	HEADER FLUORESCENT LIGHT ASSY. (3 REQ'D)
3	0336-00103-00XF	HEADER RETAINER BRKT. (2 REQ'D)
	0017-00101-0138	#8X5/8 TORX PAN HD. TAMPER PROOF SCREW (4 REQ'D)
4	A307-00014-00XF	FRONT SPEAKER GRILLE ASSY.
5	0017-00003-0430	6"X9" SPEAKER 4 OHM, 10W (4 REQ'D)
	0017-00101-0136	#8-32X1-1/4 CARRIAGE BOLT (24 REQ'D)
	0017-00103-0061	#8-32 HEX NUT W/SEMS (24 REQ'D)
6	0307-00913-0100	DECAL - RIGHT
	0307-00913-0200	DECAL - LEFT
7	0307-00905-00XF	MAIN VIEWING GLASS
8	0017-00003-0339	ELECTROHOME - 19" COLOR HORIZ MONITOR (OR)
	0017-00003-0439	WELLS-GARDNER - 19" COLOR HORIZ MONITOR (OR)
	0017-00003-0454	ZENITH - 19" COLOR HORIZ MONITOR
	0349-00101-0000	MONITOR SUPPORT RAIL (2 REQ'D)
	0555-00901-0000	PLASTIC LOCATING PIN (4 REQ'D)
	0017-00101-0141	#8X11/16 UNSLOT HEX HD M.S. (8 REQ'D)
9	0314-00902-0000	PLEXI - GLASS
	0508-00901-0000	PLEXI - GLASS MTG CLIPS (4 REQ'D)
	0017-00101-0017	#6X1/2 BLK SLT HEX HD SCR (4 REQ'D)
10	0307-00918-0000	T.V. BEZEL
11	A307-00044-0000	LIGHT PANEL ASSY.
	0360-00935-0000	SMALL SHADOW BOX (5 REQ'D)
	0017-00003-0219	#194 WEDGE BASE LAMP -14V., .27A. (5 REQ'D)
	0017-00031-0030	WEDGE BASE LAMP SOCKET (5 REQ'D)
12	A307-00018-0000	WELD STUD & CONTROL SHELF ASSY.
	0307-00911-0000	DECORATIVE OVERLAY
	0307-00132-0100	CONTROL SHELF MTG. BRKT. - RIGHT
	0307-00132-0200	CONTROL SHELF MTG. BRKT. - LEFT
	0555-00901-0000	PLASTIC LOCATING PINS (4 REQ'D)
	0017-00009-0534	BASSICK CLAMP (2 REQ'D)
	0610-00132-00ZN	STRIKE (2 REQ'D)
	0017-00101-0141	#8X11/16 UNSLOT HEX HD SCR (12 REQ'D)
	0307-00117-00XF	CONTROL SHELF HINGE
13	A307-00042-0000	CONTROL HANDLE ASSY.
14	A307-00038-0000	GEAR SHIFT ASSY.
15	A307-00033-0000	ACCELERATOR PEDAL ASSY.
16	0307-00116-0000	FLOOR
17	0307-00917-0000	DECORATIVE FLOOR OVERLAY
	0017-00101-0138	#8X5/8 TORX PAN HD. TAMPER PROOF SCR (8 REQ'D)
18	A982-00014-0004	50¢ DOUBLE COIN DOOR & CABLE ASSY.
	0017-00009-0477	MOLDED CASH BOX
	A894-00025-0000	CASH BOX COVER ASSY.
	A894-00024-0000	CASH BOX SIDE CHANNEL ASSY. - LONG
	0894-00121-0000	CASH BOX SIDE CHANNEL - LONG
19	0090-00002-04BK	LARGE COIN DOOR FRAME
	0017-00101-0121	#6-32X5/16 PHIL TRS HD SCR. (3 REQ'D)(MOUNTS COIN DOOR TO FRAME)
20	0307-00919-0000	SEAT ARRANGEMENT

NO. 307 - SPY HUNTER SIT DOWN - FRONT PARTS LIST

ORDER BY PART NUMBER ONLY

ITEM	PART NO	DESCRIPTION
21	0307-00121-00XF	SEAT COPING
22	0307-00903-00XF	REAR SEAT HEADER - INSTRUCTIONS
23	0307-00119-00XF	REAR HEADER BRKT. - MIDDLE
	0017-00101-0138	#8X5/8 TORX PAN HD TAMPER PROOF SCREW (13 REQ'D)
24	0307-00904-00XF	DISPLAY HEADER REAR - BOTTOM
25	A307-00015-00XF	REAR SPEAKER GRILLE ASSY. (NOT SEEN)
26	0017-00102-0048	3/8-16X2" LEG LEVELERS (8 REQ'D)
	0017-00103-0026	3/8-16 LEG LEVELERS HEX NUTS (8 REQ'D)
		ADDITIONAL PARTS LIST
	A307-00007-0000	CARD RACK W/BOARDS ASSY.
	A084-91657-A307	SOUND I/O P.C. BOARD ASSY.
	A307-00025-0000	SHIELD & BARRIER ASSY.
	0017-00101-0339	#6-32X3/8 PHIL RND. HD. SCREW (4 REQ'D)
	A084-91442-AA27	C.P.U. MCR-3 P.C. BOARD ASSY.
	A307-00026-0000	SHIELD ASSY. - INNER
	A084-91433-AA27	VIDEO GEN. MCR-3 P.C. BOARD ASSY.
	A307-00027-0000	SHIELD ASSY. - OUTER
	0017-00101-0153	#6-32X1" PHIL RND. HD. SCREW (8 REQ'D)
	A088-00016-0000	INTERLOCK SWITCH & SPRING BRKT. ASSY.
	0303-00904-0000	INTERLOCK SWITCH COVER
	A945-00038-0000	ON-OFF SWITCH & PLATE ASSY.
	A307-00034-0000	MULTIFUNCTION SWITCH/BRACKET ASSY.
	A945-00020-0000	POWER CHASSIS ASSY. - 125VA., 115V
	A945-00019-0000	LINE CORD ASSY. - 115V
	A084-91648-A000	DUAL POWER AMP W/MIXER ASSY. (2 REQ'D)
	A084-91649-C000	ABSOLUTE POSITION P.C. ASSY.
	A084-91673-B000	LAMP DRIVER P.C. BOARD ASSY.
	A084-91671-AA27	CHEAP SQUEAK P.C.B. ASSY.
	A084-90412-D000	POWER SUPPLY - 125VA
	0624-00902-0100	P.C. SUPPORT BRKT. - 12" LG (2 REQ'D)
	0624-00902-0200	P.C. SUPPORT BRKT. - 10" LG (2 REQ'D)
	0624-00902-0400	P.C. SUPPORT BRKT. - 4" LG (2 REQ'D)
	0624-00902-0500	P.C. SUPPORT BRKT. - 6-1/2" LG (2 REQ'D)
	0017-00104-0037	#8 FLAT WASHER (20 REQ'D)
	0017-00101-0141	#8X11/16 UNSLOT HEX HD. SCR. (20 REQ'D)
	A097-00009-0000	BACK DOOR LOCK ASSY.
	0618-00117-00XF	VENT GRILLE (4 REQ'D) - BACK DOOR

HEADER FLOURESCENT FIXTUTRE ASSY.

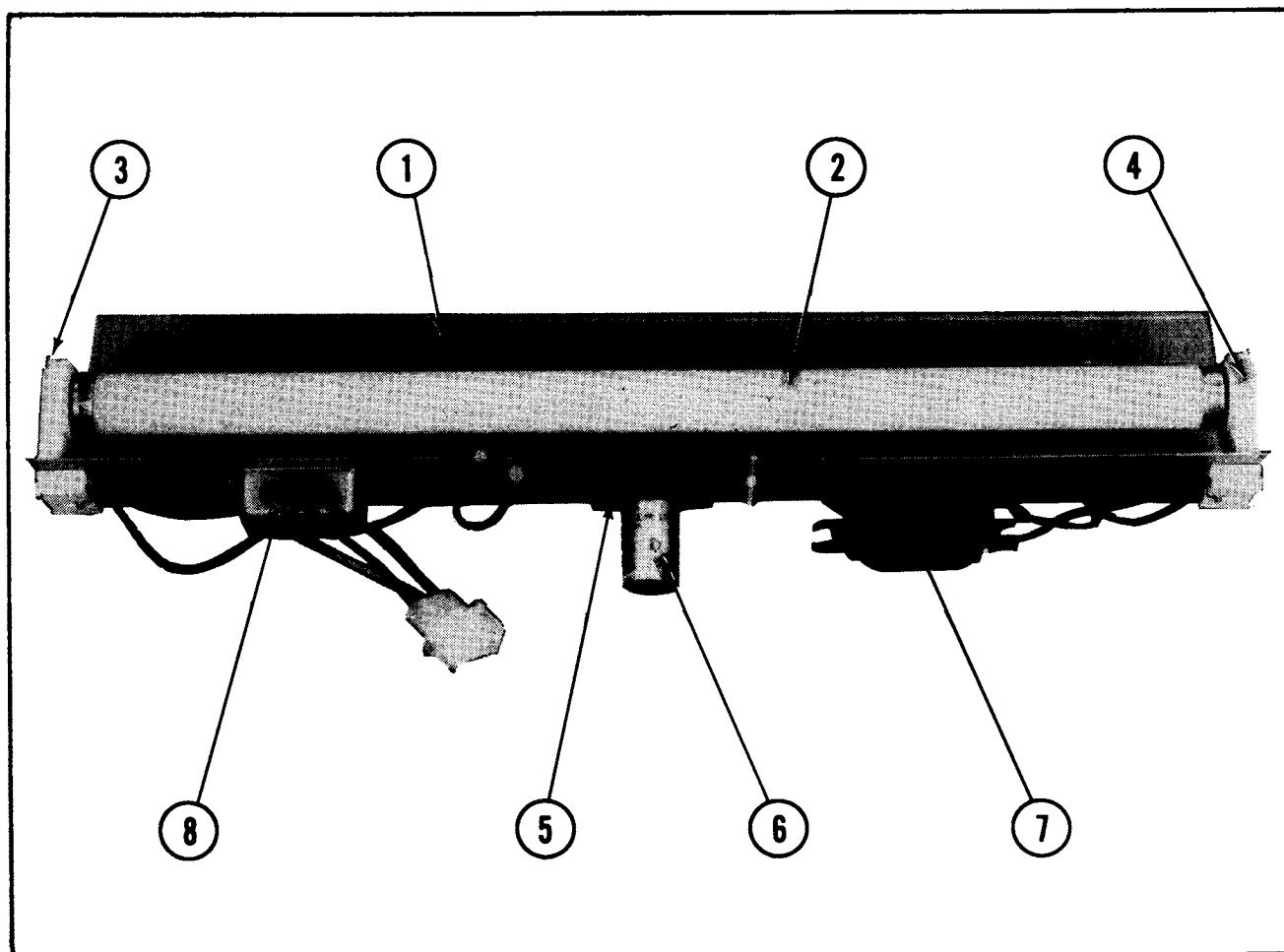

HEADER FLOURESCENT FIXTUTRE ASSY. - PARTS LIST

ORDER BY PART NUMBER ONLY

ITEM	PART NO.	DESCRIPTION
1	0595-00105-0000	FLUORESCENT BRKT.
2	0017-00003-0043	18" COOL WHITE FLUORESCENT LAMP
3	0017-00003-0445	LAMP LOCKS (2 REQ'D.)
4	0017-00031-0036	FLUORESCENT SOCKET (2 REQ'D.)
5	0017-00003-0412	FLUORESCENT STARTER HOLDER W/LEADS
	0017-00101-0573	#6-32 x 1/2 PHIL. RND. HD. M.S. (4 REQ'D.)
	0017-00104-0009	#6 EXT. WASHER (4 REQ'D.)
6	0017-00003-0019	FLUORESCENT STARTER
7	0017-00003-0026	BALLAST
	0017-00101-0598	#8-32 x 5/16 SLT. HEX HD. SCR. (4 REQ'D.)
8	A961-00042-0000	LINE FILTER ASSY.

SPY HUNTER - GEAR SHIFT ASSY.

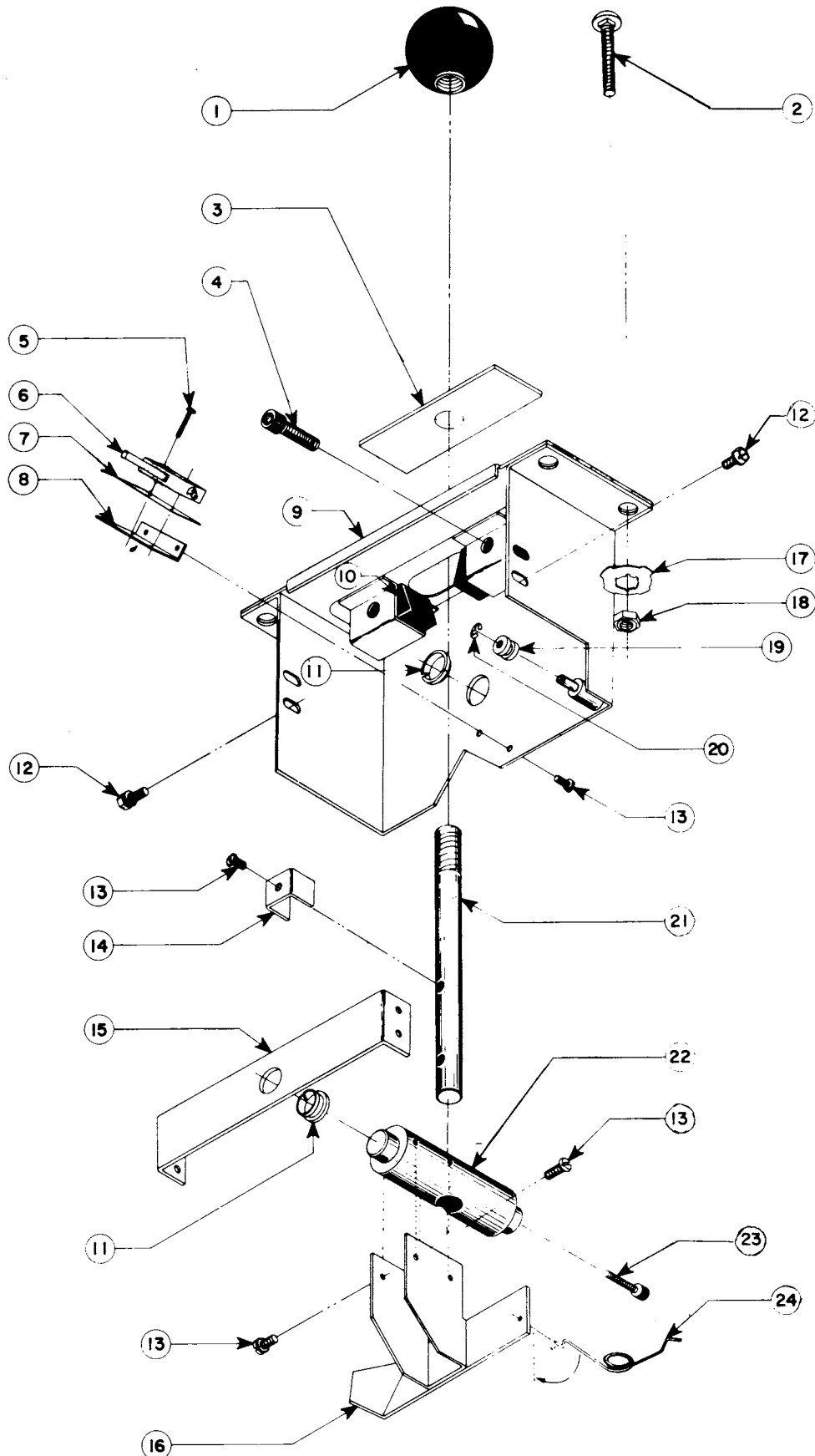

NOTE: DRAWING MAY DIFFER SLIGHTLY FROM ACTUAL ASSEMBLY

SPY HUNTER - GEAR SHIFT ASSY. - PARTS LIST

ORDER BY PART NUMBER ONLY

ITEM	PART NO.	DESCRIPTION
1	0017-00009-0561	BALL KNOB
2	0017-00102-0019	1/4-20X1-1/2 CARRIAGE BOLT (4 REQ'D)
3	0307-00912-0000	ROUND SLIDE
4	0017-00101-0668	#10-32X1" HEX SOCKET HD CAP SCREW (2 REQ'D)
5	0017-00101-0155	#4-40X9/16 PHIL PAN HD M.S. (2 REQ'D)
6	0017-00032-0006	CHERRY SWITCH
7	0307-00916-0000	SWITCH INSULATOR
8	0307-00133-0000	SWITCH MTG BRKT.
9	A307-00040-0000	CONTROL HOUSING/BEARING ASSY.
10	0941-00905-0000	BUMPERS (2 REQ'D)
11		NOT USED
12	0017-00101-0179	#10-32X3/8 PHIL PAN HD M.S. (4 REQ'D)
13	0017-00101-0593	#8-32X1/4 PAN HD M.S. W/SEMS (6 REQ'D)
14		NOT USED
15	A307-00041-0000	PLATE/BEARING ASSY.
16	A307-00036-0000	BRACKET & PLATE ASSY.
17	0017-00104-0014	PERIPHERY WASHER (4 REQ'D)
18	0017-00103-0018	1/4-20 HEX NUT (4 REQ'D)
19	0591-00702-0000	ROLLER SPRING
20	0017-00100-0015	5/32" E-RING
21	0307-00709-00XF	GEAR SHIFT ROD
22	0307-00702-00XF	PIVOT BUSHING
	A307-00039-0000	SHIFT & ROD ASSY. (ITEMS 21 & 22)
23		NOT USED
24	0010-00227-0000	TORSION SPRING

SPY HUNTER - ACCELERATOR PEDAL ASSY. SIT DOWN

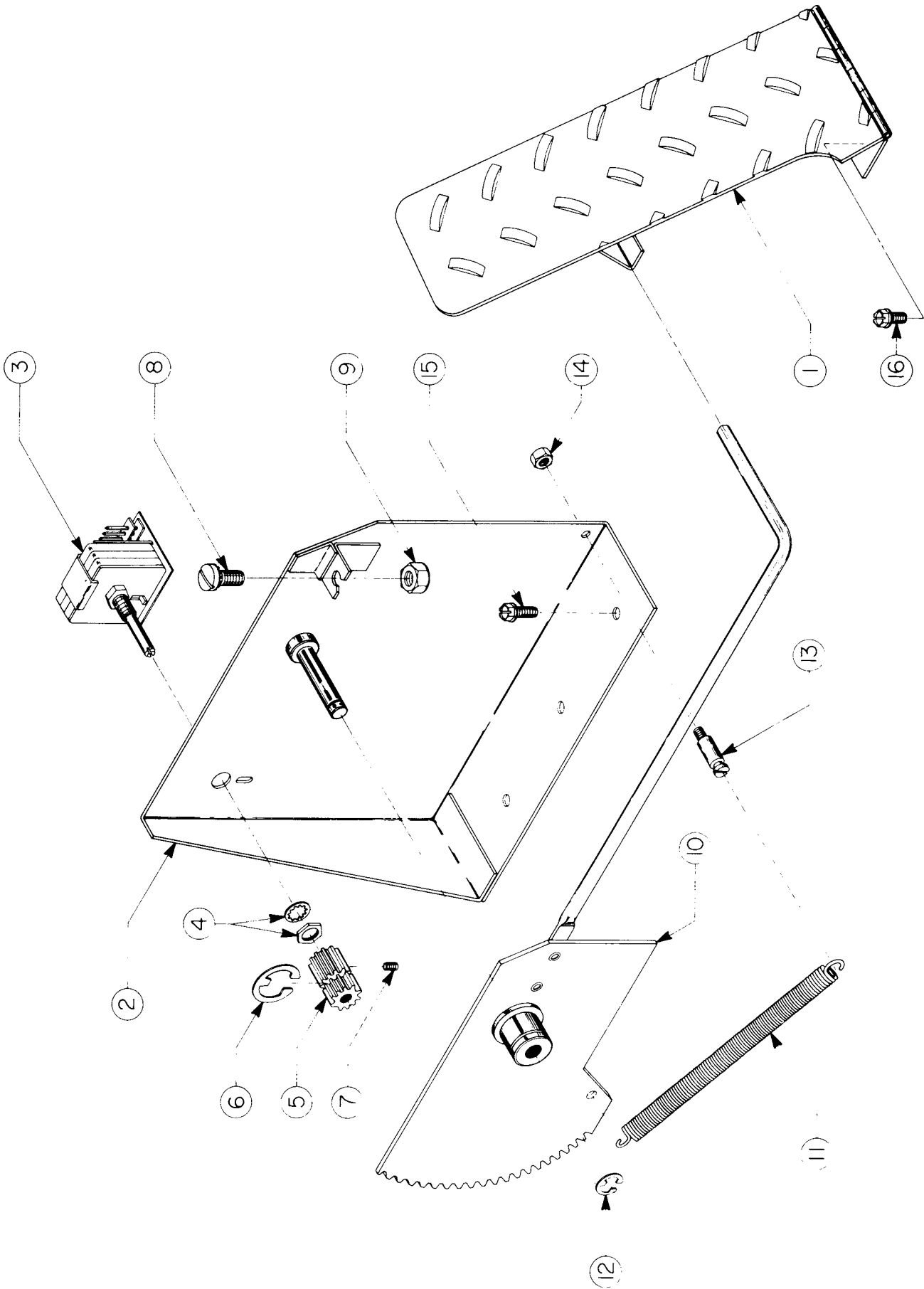

NOTE: DRAWING MAY DIFFER SLIGHTLY FROM ACTUAL ASSEMBLY

SPY HUNTER - ACCELERATOR PEDAL ASSY. SIT DOWN - PARTS LIST

ORDER BY PART NUMBER ONLY

ITEM	PART NO.	DESCRIPTION
1	A307-00016-00XF	ACCELERATOR PEDAL & HINGE ASSY.
2	A307-00017-0000	MOUNTING BRKT. ASSEMBLY
3	105E-00004-0002	POT
4		NOT USED
5	0307-00708-0000	GEAR
	A307-00032-0000	POT & GEAR ASSY. (ITEMS 3 & 5)
6		NOT USED
7		NOT USED
8	0017-00101-0785	1/4-20X1/4 SLT PAN HD EXT. M.S.
9	0653-00734-0000	STOP-POT LIMIT
10	A307-00024-0000	GEAR & LEVER ASSY.
11	0010-00228-0000	PEDAL SPRING
12	0017-00100-0122	E-RING
13	0307-00703-00XF	POST-PIVOT
14	0017-00103-0081	#10-32 HEX NUT W/SEMS
15	0017-00101-0769	#10X3/4 SLT HEX HD W/WASHER M.S. (3 REQ'D)
16	0017-00101-0598	#8-32X5/16 SLT HEX HD M.S. (2 REQ'D)
	0921-00700-0000	PLASTIC ACTUATOR - (GEAR & LEVER ASSY. SHAFT)
	0307-00125-00XF	ACCEL. PEDAL & CONTROL MTG. BRKT. - (FLOOR PLATE)
	0307-00124-00XF	PLATE COVER - (WALL PLATE)

SPY HUNTER - STEERING CONTROL ASSY.

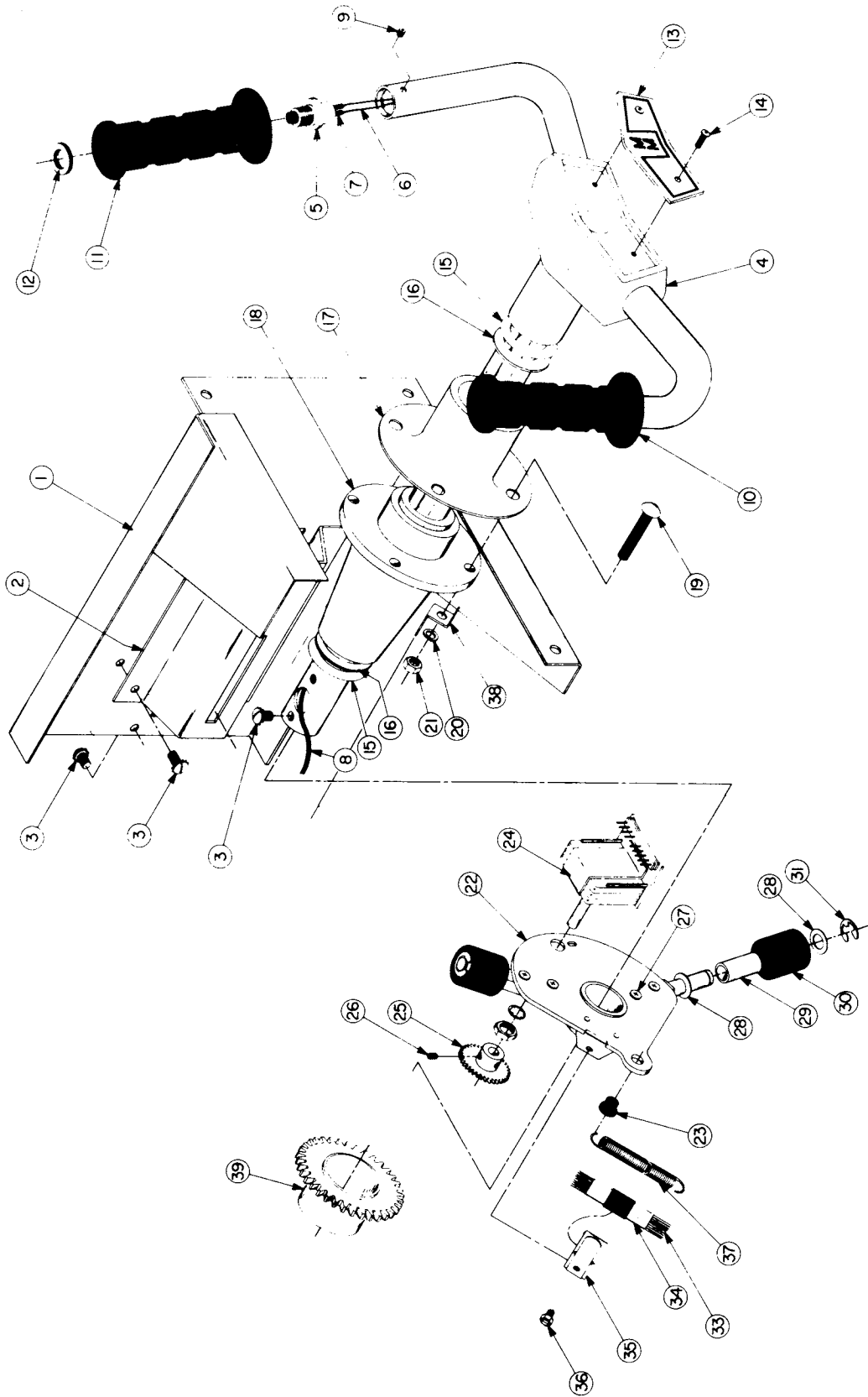

NOTE: DRAWING MAY DIFFER SLIGHTLY FROM ACTUAL ASSEMBLY

SPY HUNTER - STEERING CONTROL ASSY. - PARTS LIST

ORDER BY PART NUMBER ONLY

ITEM	PART NO.	DESCRIPTION
1	A307-00023-0000	BASE & BRACE ASSY.
2	0307-00114-0000	STOP BRKT.
3	0017-00101-0179	#10-32X3/8 PHIL PAN HD. S.M.S. (4 REQ'D)
4	A307-00028-0000	BASE, TUBE & HANDLE ASSY.
5	0017-00032-0130	PUSH BUTTON SWITCH (2 REQ'D)
	0017-00032-0132	MICRO SWITCH (2 REQ'D)
	0307-00909-0000	RED BUTTON (2 REQ'D)
	0307-00123-01XF	SWITCH MTG. BRKT. - RIGHT
	0307-00123-02XF	SWITCH MTG. BRKT. - LEFT
	0307-00908-0000	TRIGGER (2 REQ'D)
6-9		NOT USED
10	A307-00013-0200	GRIP ASSY. - LEFT
11	A307-00013-0100	GRIP ASSY. - RIGHT
12		NOT USED
13	0307-00100-00XF	STEERING WHEEL BASE PLATE
	0017-00032-0129	ILLUMINATED R.P.B. SWITCH
14	0017-00101-0149	#10-32X3/8 BUT. HD. M.S. (2 REQ'D)
	0307-00910-0000	7" BELLOW (MOUNTED ON HANDLE TUBE) (2 REQ'D)
15	0017-00041-0617	RING - NEOPRENE (2 REQ'D)
16	0645-00913-0000	WASHER - FRICTION (2 REQ'D)
17	0645-00905-0000	SHROUD
18	A645-00012-0000	PEDESTAL ASSY.
19	0017-00102-0019	1/4-20X1-1/2 CARRIAGE BOLT (4 REQ'D)
20	0017-00104-0005	1/4 - SPLIT LOCK WASHER (4 REQ'D)
21	0017-00103-0019	1/4-20 LOCK NUT (4 REQ'D)
22	A307-00022-0000	STOP PLATE ASSY.
23	0017-00042-0624	SNAP BUSHING - 3/16" (4 REQ'D)
24	105E-00004-0002	POT
25	0307-00708-0000	GEAR
	A307-00032-0000	POT & GEAR ASSY. (ITEMS 24-26)
26	0017-00007-0065	ROLL PIN
27	0017-00101-0658	#10-32X5/8 PHIL PAN HD. M.S. (4 REQ'D)
28	0017-00104-0032	FLAT WASHER (4 REQ'D)
29	0645-00906-0000	BEARING (2 REQ'D)
30	0307-00914-0000	RUBBER BUMPER (2 REQ'D)
31	0017-00100-0031	E-RING - 5/16" (2 REQ'D)
32-36		NOT USED
37	0010-00275-0379	EXTENSION SPRING (2 REQ'D)
38		NOT USED
39	0307-00705-0000	42 TOOTH GEAR
	0307-00113-0000	POT MTG. BRKT.
	A307-00046-0000	PLATE & BEARING ASSY.

— POWER CHASSIS ASSY. — 125VA., 115V.

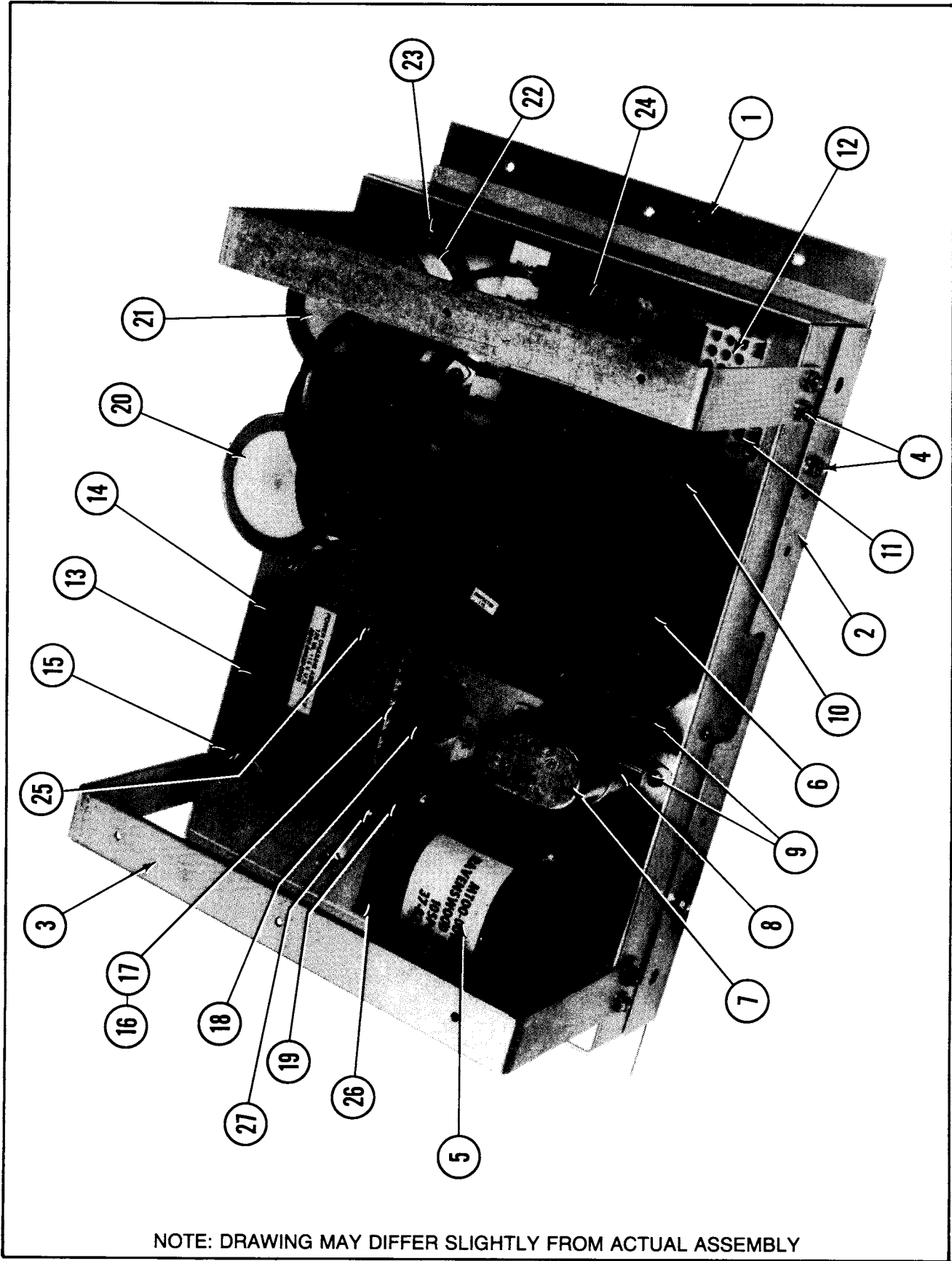

NOTE: DRAWING MAY DIFFER SLIGHTLY FROM ACTUAL ASSEMBLY

POWER CHASSIS ASSY.—125VA., 115V.—PARTS LIST

ORDER BY PART NUMBER ONLY

ITEM	PART NO.	DESCRIPTION
1	A945-00046-00XF	CHASSIS & PARTITION ASSY.
2	A945-00029-0100	MTG. PLATE & BARRIER ASSY.
3	0945-00107-01XF	STRAP (2 REQ'D.)
4	0017-00101-0123	#8 x 1/4 UNSLOT. HEX HD. SCR. (12 REQ'D.)
5	MT00-00101-A000	ISOLATION TRANSFORMER W/O SHIELD ASSY. — 115V., 50/60 HZ.
	0017-00103-0061	#8-32 HEX NUT W/SEMS (4 REQ'D.)
6	MT00-00099-A000	POWER TRANSFORMER ASSY. — 115V., 60 HZ.
	0017-00103-0084	#6-32 HEX NUT W/SEMS (4 REQ'D.)
7	0175-181T4-GXJK	CAPACITOR — 3.5 M.F., 440V.
8	0017-00009-0535	CLAMP
	0017-00101-0565	#6-32 x 7/16 SLT. PAN HD. SCR.
	0017-00103-0084	#6-32 HEX NUT W/SEMS
9	0017-00101-0067	#6 x 3/8 PHIL. PAN HD. SCR. (11 REQ'D.)
10	0945-00902-0000	SNAP BUSHING (3 REQ'D.)
11	0017-00021-0297	2 POSITION CONNECTOR
12	A945-00030-0100	CONNECTOR & CABLE ASSY. #1
13	A945-00030-0200	CONNECTOR & CABLE ASSY. #2
14	A945-00021-0000	CONVENIENCE OUTLET ASSY.
15	0017-00101-0573	#6-32 x 1/2 PHIL. RND. HD. SCR. (2 REQ'D.)
	0017-00103-0084	#6-32 HEX NUT W/SEMS (2 REQ'D.)
	A945-00025-0000	FILTER ASSEMBLY — 125V. — UNDER CHASSIS (NOT SEEN)
16	0017-00021-0510	TERMINAL STRIP
17	0017-00101-0140	#4-40 x 5/16 PHIL. PAN HD. SCR. (2 REQ'D.)
18	0017-00003-0263	SLO-BLO FUSE — 4A., 250V.
19	0017-00003-0005	FUSE — 2A., 250V.
	0017-00003-0444	QUICK CONN. FUSEHOLDER (2 REQ'D.) — FOR ABOVE FUSES
20	0945-00816-1902	CAPACITOR — 100,000 M.F.
21	0945-00816-1901	CAPACITOR — 55,000 M.F.
	0017-00104-0107	#10 FLAT WASHER (4 REQ'D.)
	0017-00103-0081	#10-32 HEX NUT W/SEMS (4 REQ'D.)
22	0017-00009-0422	CLAMP (2 REQ'D.)
	0017-00101-0758	#8-32 x 3/4 PHIL. RND. HD. SCREW (2 REQ'D.)
	0017-00103-0061	#8-32 HEX NUT W/SEMS (2 REQ'D.)
23	0017-00101-0067	#6 x 3/8 PHIL. PAN HD. SCR. (6 REQ'D.)
24	0945-00904-0000	5 POSITION FUSE HOLDER
	0017-00003-0263	SLO-BLO FUSE — 4A., 250V.
	0017-00003-0217	SLO-BLO FUSE — 2.5A., 250V. (2 REQ'D.)
	0017-00003-0007	SLO-BLO FUSE — 3A., 250V. (2 REQ'D.)
	0945-00903-0000	FUSE HOLDER BARRIER
	A945-00022-0000	HEATSINK & DIODE ASSY.
	0017-00101-0067	#6 x 3/8 PHIL. PAN HD. SCR. (2 REQ'D.)
25	0017-00101-0780	#6 x 1/2 PHIL. PAN HD. SCREW (2 REQ'D.)
	0017-00021-0629	5 POSITION TERMINAL STRIP — (UNDER CHASSIS)
	A945-00019-0000	LINE CORD ASSY. — 115V. (NOT SHOWN)
26	A945-00030-0500	CONNECTOR & CABLE ASSY.
27	0017-00101-0660	#10-32 x 3/4 PAN HD. SCREW
	0017-00104-0107	#10 FLAT WASHER
	0017-00103-0081	#10-32 HEX NUT W/SEMS

FRONT DOOR ASSEMBLY - U.S.A. 50¢

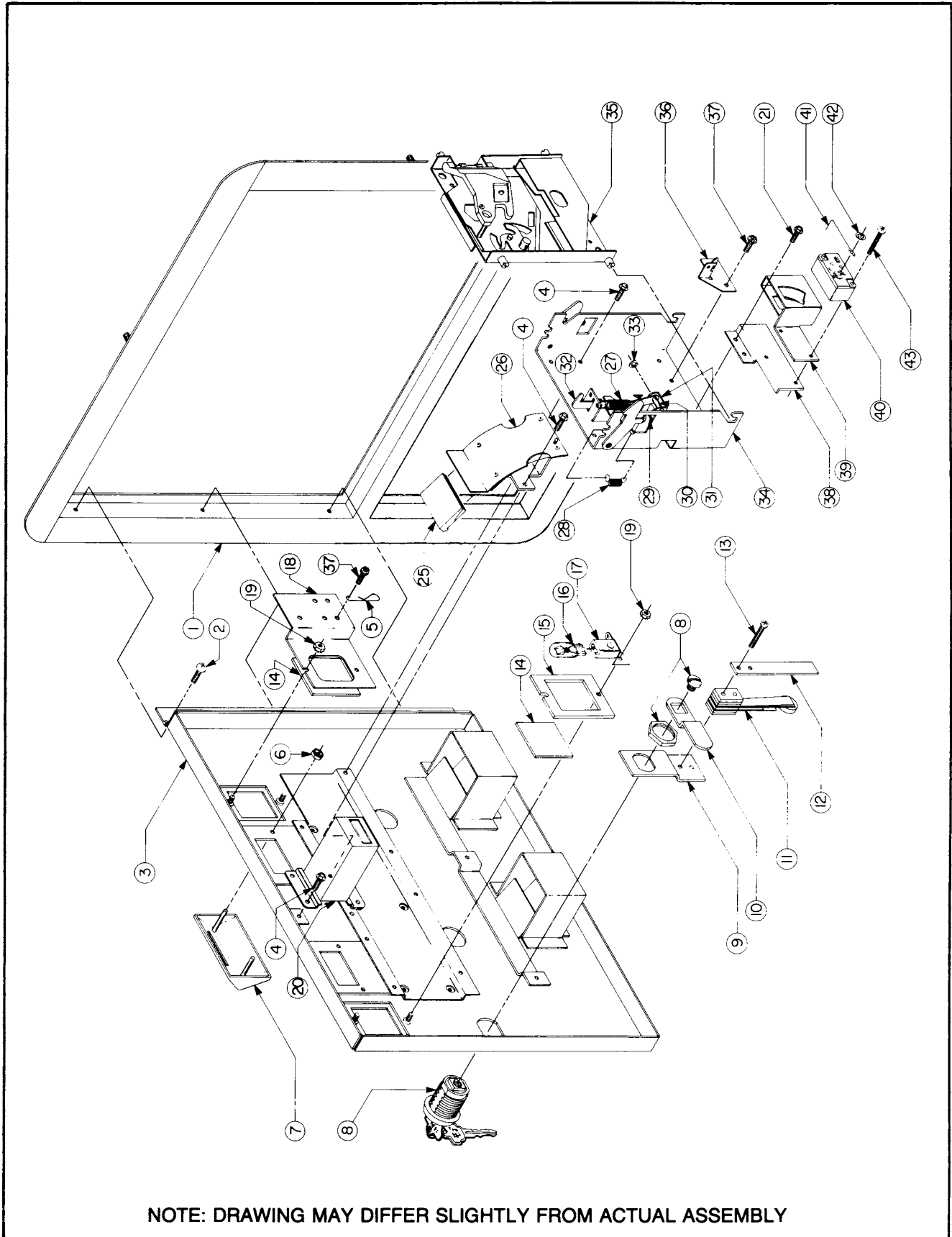

FRONT DOOR ASSEMBLY - U.S.A. 50¢ - PARTS LIST

ORDER BY PART NUMBER ONLY

ITEM	PART NO.	DESCRIPTION
1	A090-00603-00XF	DOUBLE ENTRY COIN DOOR FRAME
2	0017-00101-0121	#6-32x5/16 PHIL. TRS. HD. SCR. (3 REQ'D)
3	A090-00073-02BK	DOUBLE ENTRY COIN DOOR W/DRESS PLATE
4	0017-00101-0123	#8x1/4 UNSLOT HEX HD. SCREW (12 REQ'D)
5	0017-00007-0019	KEY HOOK
6	0017-00103-0059	PUSH NUT (4 REQ'D)
7	0090-00912-0000	COIN ENTRY PLATE - 25¢ (2 REQ'D)
8	A097-00005-0000	DOOR LOCK & KEY W/SCREW & NUT (OR)
	A097-00006-0000	DOOR LOCK & KEY W/SCREW & NUT
9	0090-00128-00XF	DOOR TILT SWITCH BRKT.
10	0017-00005-0041	DOOR CAM
11	A090-00095-0000	DOOR TILT SWITCH
12	0090-00126-03XF	SWITCH BACK-UP PLATE
13	0017-00101-0525	#5-40x9/16" PHIL. HD. M.S. (2 REQ'D)
	A090-00096-0000	DOOR TILT SWITCH & BRKT. ASSY. (ITEMS 9 & 11 THRU 13)
14	0090-00903-4800	PLEXI PLATE 2x25 CENT 1 PLAY (2 REQ'D)
15	0090-00143-00XF	COIN PLEX RETAINER
16	0017-00003-0219	12 VOLT LAMP - G.E. #194 (2 REQ'D)
17	0017-00031-0048	WEDGE SOCKET W/BRKT. (2 REQ'D)
18	A090-00100-0000	BRKT. ASSY.
19	0017-00103-0084	#6-32 HEX NUT W/SEMS (4 REQ'D)
20	A090-00089-0000	COIN METER W/DIODE
21	0017-00101-0124	#6x1/4 UNSLOT HEX HD. SCR. (4 REQ'D)
25	0090-00911-0000	INSULATOR (2 REQ'D)
26	A090-00112-0000	COIN CHUTE & INSULATOR ASSY. (2 REQ'D)
27	0010-00134-0000	SPRING
28	0010-00181-0000	SPRING
29	0017-00007-0083	1/8x1-5/8 ROLL PIN
30	0090-00129-00XF	PIVOT POST
31	0090-00167-00XF	PIVOT LEVER
32	0090-00182-00XF	REJECT LEVER
33	0017-00100-0018	E-RING
	A090-00088-0000	REJECT LEVER ASSY. (2 REQ'D) (ITEMS 30 THRU 33)
34	A090-00117-0000	COIN ACCEPTOR FRAME ASSY. (2 REQ'D)
35	0017-00005-0003	COIN ACCEPTOR W/STRING CUTTER (2 REQ'D) (OR)
	0017-00005-0211	COIN ACCEPTOR W/ANTI STRING DEVICE (2 REQ'D) (OR)
	0017-00005-0214	COIN ACCEPTOR W/STRING CUTTER (2 REQ'D)
36	A090-00064-0000	ANTI-PENNY DEVICE
37	0017-00101-0099	#6x1/4 SLT. HEX HD. M.S. (2 REQ'D)
38	0090-00162-00XF	COIN SWITCH MTG. BRKT.
39	0017-00005-0203	COIN SWITCH CHUTE
40	0017-00005-0195	COIN SWITCH
41	0010-00599-0000	COIN SWITCH WIRE
42	0017-00007-0015	PUSH-ON RING
	A090-00059-0400	COIN SWITCH & WIRE ASSY. (ITEMS 40 THRU 42)
43	0017-00101-0147	#4-40x3/4 PHIL. PAN HD. M.S. (2 REQ'D)
	A090-00077-0000	COIN GUIDE & SWITCH ASSY. (ITEMS 38 THRU 43)

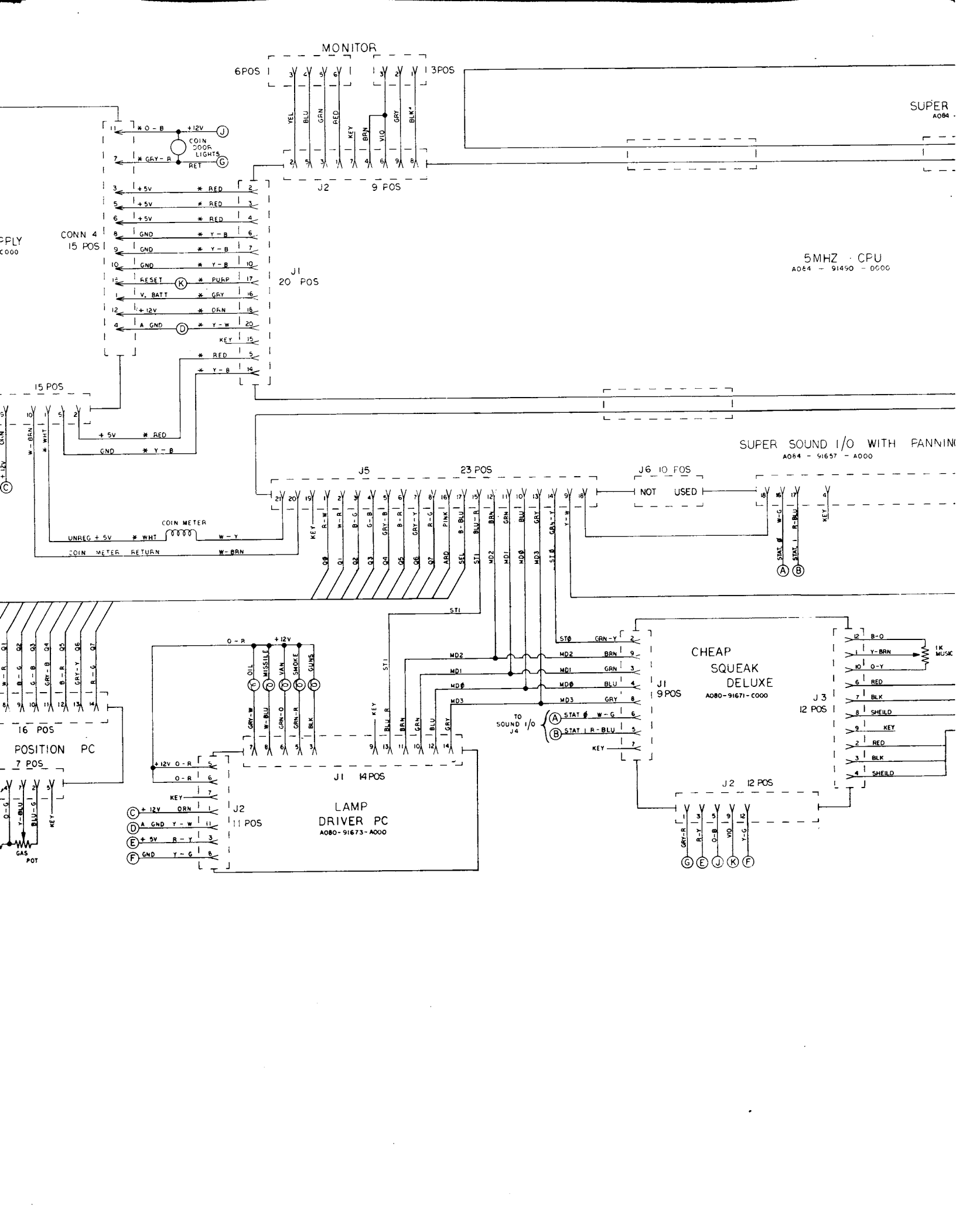

TING

USK POT

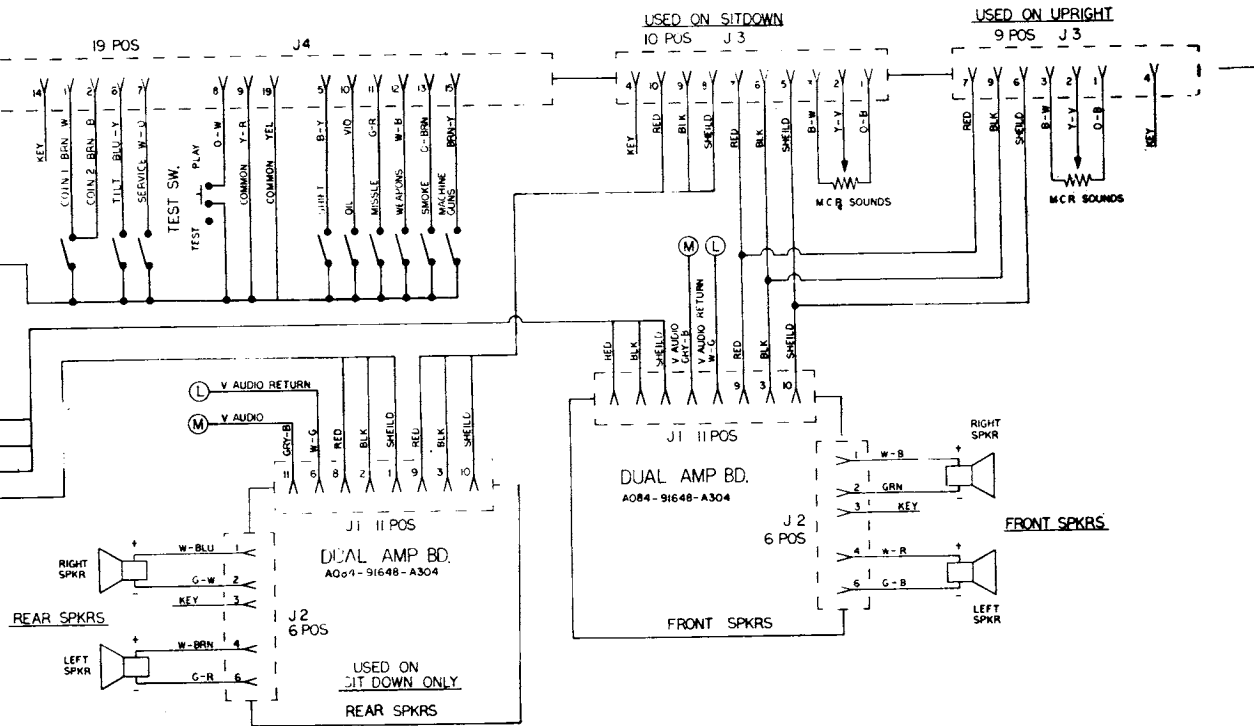

DESIGNATION LIST

<u>DESIGNATION NO.</u>	<u>DESCRIPTION</u>	<u>DESIGNATION NO.</u>	<u>DESCRIPTION</u>
C101-C104	CAP 100 PF AX CER	4C	74LS258
C105	CAP .01 MF AX CER	5C	74LS00
		6C	74LS04
CP1-CP3	.01 MF AX CER	7C	74LS74
CP4	10 MF 25V AX TANT	8C	74LS30
CP5-CP8	.01 MF AX CER	9C	74LS169
CP9	10 MF 25V AX TANT	10C	74LS169
CP10-CP18	.01 MF AX CER	11C	74LS169
CP19	10 MF 25V AX TANT	12C	74LS169
CP20-CP22	.01 MF AX CER	13C	74S133
CP23	10 MF 25V AX TANT		
CP24-CP31	.01 MF AX CER	1D	7420
CP32	10 MF 25V AX TANT	2D	93422
CP33-CP36	.01 MF AX CER	3D	93422
CP37	10 MF 25V AX TANT	4D	7420
CP38-CP43	.01 MF AX CER	5D	93422
CP44	10 MF 25V AX TANT	6D	93422
CP45-CP48	.01 MF AX CER	7D	93422
CP49	10 MF 25V AX TANT	8D	93422
CP50-CP56	.01 MF AX CER	9D	93422
CP57	10 MF 25V AX TANT	10D	93422
CP58,CP59	.01 MF AX CER	12D	STAT RAM
CP60	10 MF 25V AX TANT	13D	74LS245
CP61-CP67	.01 MF AX CER		
CP68	10 MF 25V AX TANT	1E	74LS74
CP69,CP70	.01 MF AX CER	2E	74LS74
CP71	10 MF 25V AX TANT	3E	74S157
CP72-CP76	.01 MF AX CER	4E	74S00
CP77,CP78	10 MF 25V AX TANT	5E	74LS32
CP79-CP81	.01 MF AX CER	6E	74LS174
CP82,CP83	100 MF AX ELECT	7E	74LS283
		8E	74LS175
		9E	74LS157
R101-R118	1K OHM 1/4W	10E	74LS157
R119,R120	560 OHM 1/4W	11E	74S161
R122,R124	1K OHM 1/4W	12E	74LS157
R125	100 OHM 1/4W	13E	74LS157
RM1	1K 6 PIN SIP	1F	74S74
RM2, RM3	1K 10 PIN SIP	2F	74S86
RM4, RM5	1K 9 PIN SIP	3F	74S08
RM6, RM7	82 OHM 8 PIN SIP	4F	74LS30
		5F	74LS30
1A	EPROM VG-A	6F	7420
2A	EPROM VG-B	7F	74LS283
3A	EPROM VG-C	8F	74LS174
4A	EPROM VG-D	9F	74LS10
5A	EPROM VG-E	10F	74LS157
6A	EPROM VG-F	11F	74S04
7A	EPROM VG-G	12F	74LS157
8A	EPROM VG-H	13F	74LS157
9A	74LS86		
10A	74LS86	1G	74LS32
12A	74LS273	2G	74LS273
13A	74S04	3G	74LS240
		12G	7420
1B	74LS194	13G	74LS74
2B	74LS194		
3B	74LS194	ICS 1A-8A	28 PIN IC SOCKET
4B	74LS194	ICS 2D, 3D, 5D-10D	22 PIN IC SOCKET
5B	74LS194	ICS 12D	24 PIN IC SOCKET
6B	74LS194		
7B	74LS194		
8B	74LS194		
9B	74LS161	J5-J7	KK 100 24 PIN RT ANGLE
10B	74LS174		
11B	74LS174		
12B	74S283	JW1, JW2	JUMPER WIRE
13B	74S283		
		BB1, BB2	BUSS BAR
1C	74LS258		
2C	74LS258		
3C	74LS258		

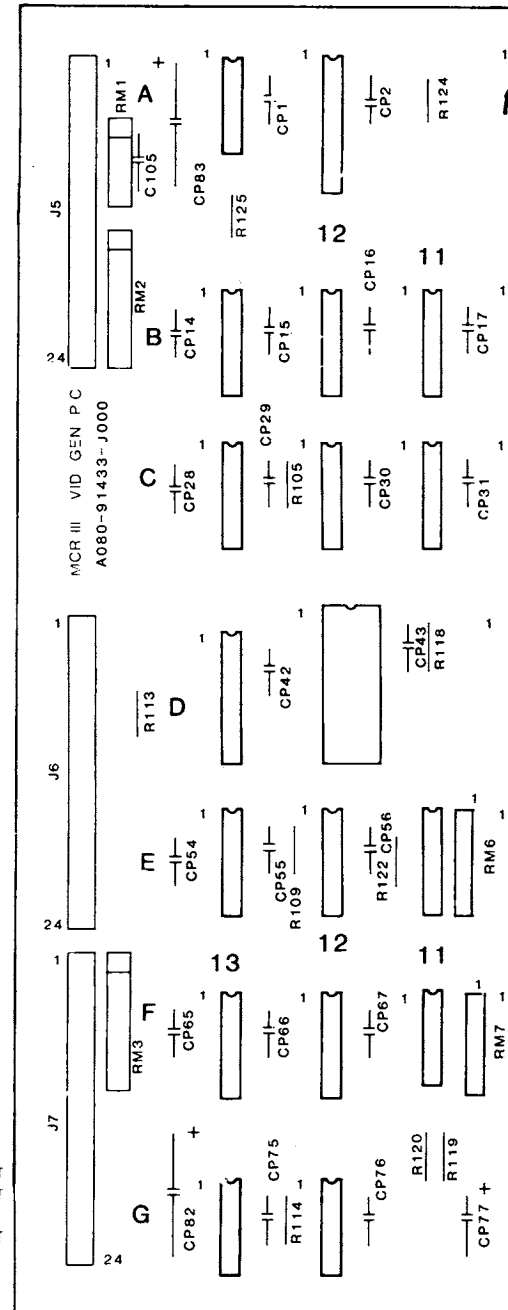

CROSS REFERENCE LIST

DESIGNATION NO.	PART NOS.	DESCRIPTION	QTY	DESIGNATION NO.	PART NOS.
CP1-CP3, CP5-CP8, CP10-CP18, CP20- CP22, CP24-CP31, CP33-CP36, CP38- CP43, CP45-CP48, CP50-CP56, CP58, CP59, CP61-CP67, CP69, CP70, CP72- CP76, CP79-CP81, C105	0986-00800-2500	STAT RAM 93422	1 8	12D 2D, 3D, 5D-10D	0304-00803-0034 0986-00803-1010
CP4, CP9, CP19, CP23, CP32, CP37, CP44, CP49, CP57, CP60, CP68, CP71, CP77, CP78	0986-00800-2400	22 PIN IC SOCKET	8	ICS 2D, 3D, 5D- 10D	0986-00804-0700
CP82, CP83 C101-C104	0986-00800-1800 0986-00800-1000	24 PIN IC SOCKET 28 PIN IC SOCKET	1 8	ICS 12D ICS 1A-8A	0986-00804-1600 0986-00804-0300
R125 R119, R120 R101-R118, R122, R124	100E-00005-0033 100E-00005-0054 100E-00005-0061	KK 100 24 PIN RT ANGLE	3	J5-J7	0986-00804-4700
RM6, RM7 RM1 RM4, RM5 RM2, RM3	102E-00004-0035 102E-00004-0009 102E-00004-0011 102E-00004-0013	JUMPER WIRE	2	JW1, JW2	0986-00805-0200
5C 4E 6C 13A, 11F 3F 9F 1D, 4D, 6F, 12G 8C, 4F, 5F 5E, 1G 7C, 1E, 2E, 13G 1F 9A, 10A 2F 13C 9E, 10E, 12E, 13E, 10F, 12F, 13F 3E 9B 11E 9C-12C 10B, 11B, 6E, 8F 8E 1B-8B 3G 13D 1C-4C 12A, 2G 7E, 7F 12B, 13B	0304-00803-0009 0304-00803-0045 0986-00803-1007 0986-00803-3100 0304-00803-0037 0304-00803-0008 0304-00803-0006 0304-00803-0016 0986-00803-0600 0986-00803-1005 0986-00803-1500 0986-00803-4200 0304-00803-0049 0304-00803-0002 0986-00803-2400 0304-00803-0044 0986-00803-1003 0304-00803-0038 0304-00803-0007 0986-00803-2900 0304-00803-0050 0986-00803-3000 0304-00803-0004 0986-00803-3800 0986-00803-3900 0304-00803-0039	BUSS BAR	2	BB1, BB2	0986-00804-0900
8A 7A 6A 5A 4A 3A 2A 1A	0A27-00803-0016 0A27-00803-0017 0A27-00803-0018 0A27-00803-0019 0A27-00803-0020 0A27-00803-0021 0A27-00803-0022 0A27-00803-0023				

REVISIONS	

PROJECT ENG: R.A. PLOUSSARD		USED ON SPY HUNTER		 FRANKLIN PK. ILL.	
DO NOT SCALE DWG		HEAT TREAT	SCALE FULL		
DIM. TOLERANCES UNLESS SPECIFIED	DRW. RLW	MAT'L.	MCR III VIDEO GEN. P.C. ASSEMBLY DWG. A080-91433-J000		PART NO.
DIM. ENTERED IN DRG. FRACTIONAL DECIMAL HOLE DIA TYPICAL	CHKD. DATE 10/31/83	FINISH			M051 - 00304 - J001

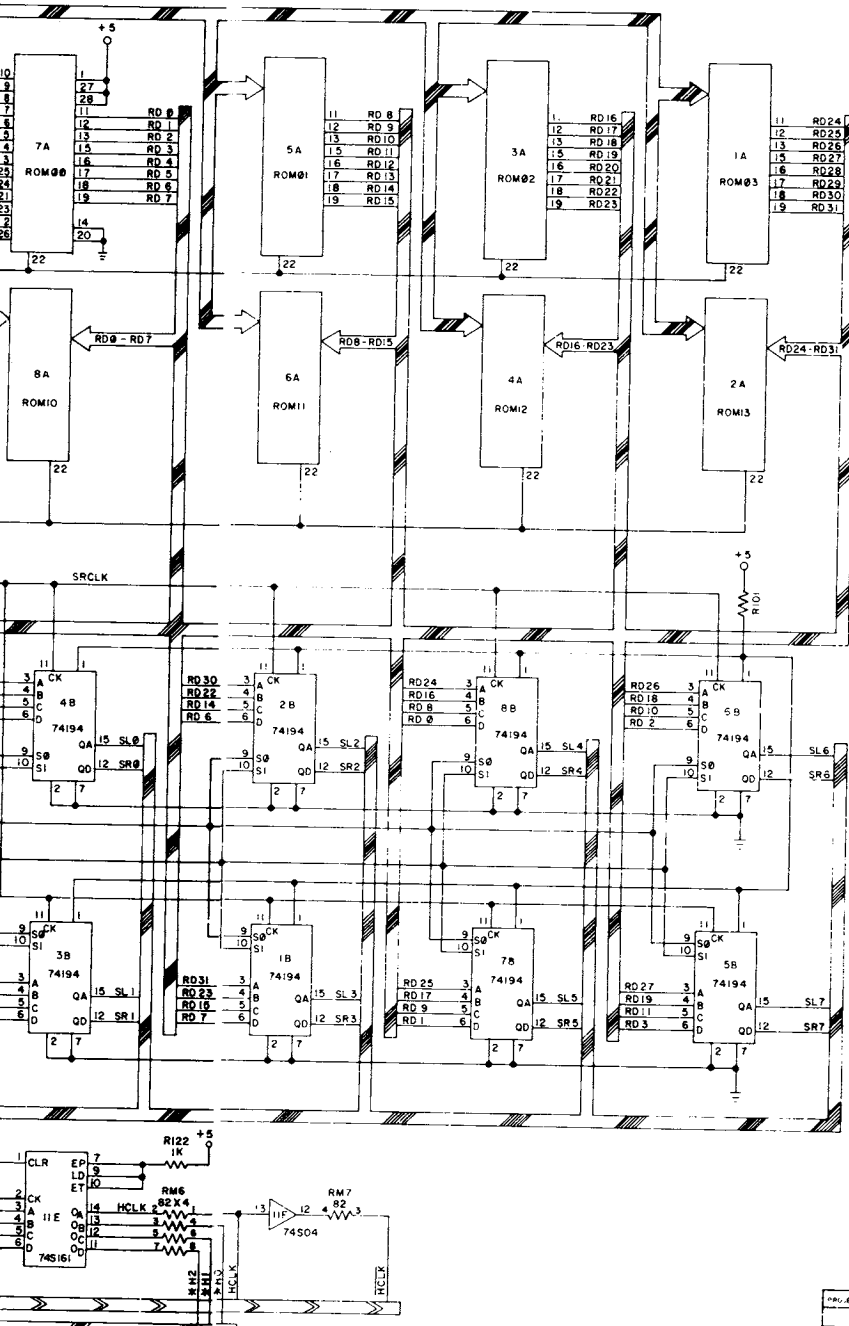

24 PIN RIBBON CABLE

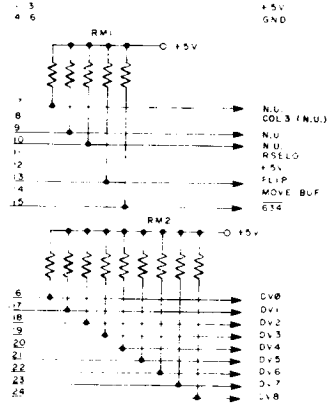

24 PIN RIBBON CABLE

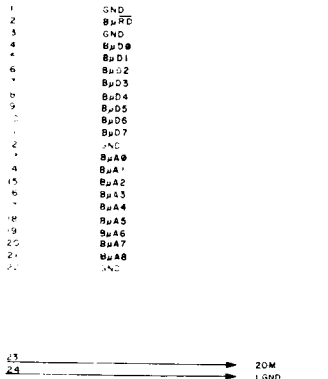

4 PIN RIBBON CABLE

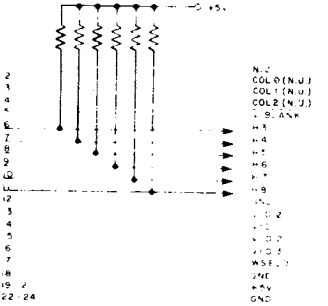

72 PIN TEST CONN (EDGE)

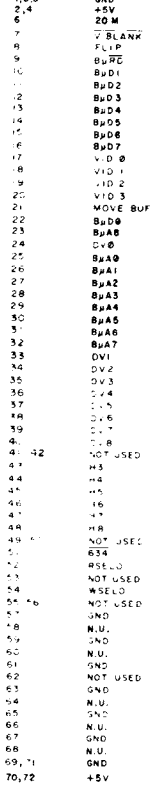

PROJECT ENG	R. A. PLOUSSARD	DESIGNED BY	USER ON	SPY HUNTER	REVISIONS
DATE	1-17-79	NO. REVISIONS	PER		
SCHEMATIC DWG			PART NO.		
V. DEO GEN III			M051 - 00304 - J002		
4082-91433-J000					

DESIGNATION LIST

<u>DESIGNATION NO.</u>	<u>DESCRIPTION</u>	<u>DESIGNATION NO.</u>	<u>DESCRIPTION</u>	<u>DESIGNATION NO.</u>	<u>DESCRIPTION</u>
C101-C103	10 MF 25V AX. TANT.	R152	1MEG. OHM 1/4W 5X CRBN.	D101-D103 D105-D107	1N4148 1N4148
C104-C127 C128,C129 C131	.1 MF 50V AX. CER. 47 PF 50V AX. CER. 10 MF 25V AX. TANT.	R153	1K OHM 1/4W 5X CRBN.	Q101-Q103 Q104	T1P110 2N4403
C134-C137 C138	1 MF 20V AX. TANT. 10 MF 25V AX. TANT.	R154	1MEG. OHM 1/4W 5X CRBN.	IC1A	7406
C139	.047 MF 100V MYLAR	R155,R156	10K OHM 1/4W 5X CRBN.	IC3A,4A	74LS273
C140	.01 MF 50V AX. CER.	R157,R158	1.2K OHM 1/4W 5X CRBN.	IC5A	74LS374
C142	100 PF 50V AX. CER.	R160,R161	330 OHM 1/4W 5X CRBN.	IC6A	1K X 8 RAM
C143	.1 MF 50V AX. CER.	R162	220 OHM 1/4W 5X CRBN.	IC7A	ROM/EPROM 0
C144	33 PF 50V AX. CER.	R163	1.2K OHM 1/4W 5X CRBN.	IC8A	ROM/EPROM 1
C145-C156	.0022 MF 100V 10X MYLAR	R164	22 OHM 1/4W 5X CRBN.	IC9A	ROM/EPROM 2
C157-C159 C161	1 MF 20V AX. TANT. 330 PF 50V AX. CER.	R165,R166	4.7K OHM 1/4W 5X CRBN.	IC10A	ROM/EPROM 3
C162-C164 C165	1 MF 20V AX. TANT. 330 PF 50V AX. CER.	R173-R178	5.6K OHM 1/4W 5X CRBN.	IC11A	74LS245
C166,C167	10 MF 25V AX. TANT.	R179	24K OHM 1/4W 5X CRBN.	IC12A	Z-80 CPU
C172	10 MF 25V AX. TANT.	R196	24K OHM 1/4W 5X CRBN.	IC13A	74LS08
C173	.01 MF 50V AX. CER.	R197-R202	5.6K OHM 1/4W 5X CRBN.	IC2B,4B,5B	74LS244
C501-C509	.1 MF 50V AX. CER.	R203-R208	33K OHM 1/4W 5X CRBN.	IC7B,8B	74LS138
CP1	470 MF 16V AX. ELECT.	R209-R211	13K OHM 1/4W 5X CRBN.	IC9B	74LS670
CP2-CP12	.01 MF 50V AX. CER.	R213	27K OHM 1/4W 5X CRBN.	IC10B	74LS32
CP13	470 MF 16V AX. ELECT.	R214-R219	33K OHM 1/4W 5X CRBN.	IC11B	74LS670
CP14-CP19	.01 MF 50V AX. CER.	R220-R222	13K OHM 1/4W 5X CRBN.	IC12B,13B	74LS138
CP20	10 MF 25V AX. TANT.	R225,R226	4.7K OHM 1/4W 5X CRBN.	IC14B	74LS174
CP21-CP27	.01 MF 50V AX. CER.	R227	1K OHM 1/4W 5X CRBN.	IC6C	7407
CP29-CP33	.01 MF 50V AX. CER.	R228	4.7K OHM 1/4W 5X CRBN.	IC10C	MC3403
CP34	10 MF 25V AX. TANT.	R231	300 OHM 1/4W 5X CRBN.	IC11C	74LS04
CP35-CP46	.01 MF 50V AX. CER.	R232	4.7K OHM 1/4W 5X CRBN.	IC12C	MC14024
CP47	470 MF 16V AX. ELECT.	R233	3K OHM 1/4W 5X CRBN.	IC13C	7427
CP48-CP51	.01 MF 50V AX. CER.	R234,R235	4.7K OHM 1/4W 5X CRBN.	IC14C	74LS367
CP52,CP53	10 MF 25V AX. TANT.	R239	100 OHM 1/4W 5X CRBN.	IC3D	LM3900
CP54	470 MF 16V AX. ELECT.	R301-R306	2.7K OHM 1/4W 5X CRBN.	IC6D	74LS02
CP202-CP204	10 MF 25V AX. TANT.	R401	1K OHM 1/4W 5X CRBN.	IC7D-9D	MC14016
R101-R107	4.7K OHM 1/4W 5X CRBN.	R402	4.7K OHM 1/4W 5X CRBN.	IC11D	74190
R108-R131	220 OHM 1/4W 5X CRBN.	R403,R404	33K OHM 1/4W 5X CRBN.	IC12D	PROMSB2A
R135	33K OHM 1/4W 5X CRBN.	R405-R407	4.7K OHM 1/4W 5X CRBN.	IC13D	74166
R138,R141	180K OHM 1/4W 5X CRBN.	R501-R509	220 OHM 1/4W 5X CRBN.	IC2E	74LS244
R142	100K OHM 1/4W 5X CRBN.	R510	2.7K OHM 1/4W 5X CRBN.	IC10E	MC3403
R144,R145	620K OHM 1/4W 5X CRBN.	RM1	4.7K OHM 10 PIN S.I.P.	IC11E	74161
R146	10K OHM 1/4W 5X CRBN.	RM2-RM5	2.7K OHM 10 PIN S.I.P.	IC12E	74126
R148	100K OHM 1/4W 5X CRBN.	RM7	4.7K OHM 8 PIN S.I.P.	IC2F	74LS244
R149,R150	620K OHM 1/4W 5X CRBN.	RM8	820 OHM 8 PIN S.I.P.	IC3F-5F	74LS191
R151	10K OHM 1/4W 5X CRBN.	RM9	1.8K OHM 10 PIN S.I.P.	IC6F,7F	AY-3-8910
		RM14	4.7K OHM 10 PIN S.I.P.	IC8F-10F	74LS191
				IC11F	7474
				IC12F	74S04
				ICS6A-ICS10A	24 PIN IC SOCKET
				ICS12A	40 PIN IC SOCKET
				ICS12D	16 PIN IC SOCKET
				ICS6F,7F	40 PIN IC SOCKET
				J1,J2	24 PIN KK100 RT. ANGLE
				J3	9 PIN KK100 RT. ANGLE OMIT 4
				J4	19 PIN KK100 RT. ANGLE OMIT 14
				J5	23 PIN KK100 RT. ANGLE OMIT 19
				J6	10 PIN KK100 RT. ANGLE OMIT 8
				JW1,JW2	JUMPER WIRE
				LED 3	YELLOW LED
				SW1	10 POSITION DIP
				SW3	8 POSITION DIP
				SW4	PUSHBUTTON S.W.
				XTAL 1	16 MHZ XTAL
				MHQ101-MHQ103	SNAP
				A080-90913-G000	SUPER SND. I/O BD.

CROSS REFERENCE LIST

<u>QTY</u>	<u>DESIGNATION NO.</u>	<u>PART NOS.</u>	<u>DESCRIPTION</u>	<u>QTY</u>	<u>DESIGNATION NO.</u>	<u>PART NOS.</u>
1	C144	0986-00800-0300	1N4148	6	D101-D103, D105-D107	0986-00801-0200
2	C128, C129	0986-00800-2800	2N4403	1	Q104	0986-00802-0500
1	C142	0986-00800-1000	T1P110	3	Q101-Q103	0986-00802-0400
2	C161, C165	0986-00800-1300	74LS02	1	IC 6D	0986-00803-7400
12	C145-C156	0986-00800-1200	74LS04	1	IC 11C	0986-00803-6900
1	C139	0986-00800-2600	74S04	1	IC 12F	0986-00803-6600
47	CP2-CP12, CP14-CP19, CP21-CP27, CP29-CP33, CP35-CP46, CP48-CP51, C140, C173	0986-00800-2000	7406	1	IC 1A	0986-00803-7600
34	C104-C127, C143, C501-C509	0986-00800-1100	7407	1	IC 6C	0986-00803-5900
8	C134, C137, C157-C159, C162-C164	0986-00800-1400	74LS08	1	IC 13A	0986-00803-7300
15	CP20, CP34, CP52, CP53, CP202-CP204, C101-C103, C131, C138, C166, C167, C172	0986-00800-0700	7427	1	IC 13C	0986-00803-7200
4	CP1, CP13, CP47, CP54	0986-00800-2700	74LS32	1	IC 10B	0986-00803-6100
1	R164	0062-063B3-1XXX	7474	1	IC 11F	0986-00803-6700
1	R239	0062-110B3-1XXX	74126	1	IC 12E	0986-00803-6800
34	R108-R131, R162, R501-R509	0062-133B3-1XXX	74LS138	4	IC7B, 8B, 12B, 13B	0986-00803-6500
1	R231	0062-141B3-1XXX	74161	1	IC 11E	0986-00803-5100
2	R160, R161	0062-144B3-1XXX	74166	1	IC 13D	0986-00803-5300
3	R153, R227, R401	0062-179B3-1XXX	74LS174	1	IC 14B	0986-00803-7500
3	R157, R158, R163	0062-183B3-1XXX	74190	1	IC 11D	0986-00803-9400
7	R301-R306, R510	0062-199B3-1XXX	74LS191	6	IC3F-5F, 8F-10F	0986-00803-5600
1	R233	0062-201B3-1XXX	74LS244	5	IC2B, 4B, 5B, 2E, 2F	0986-00803-4800
19	R101-R107, R165, R166, R225, R226, R228, R232, R234, R235, R402, R405-R407	0062-211B3-1XXX	74LS245	1	IC 11A	0986-00803-6400
12	R173-R178, R197-R202	0062-215B3-1XXX	74LS273	2	IC3A, 4A	0986-00803-4700
4	R146, R151, R155, R156	0062-227B3-1XXX	74LS367	1	IC 14C	0986-00803-7000
6	R209-R211, R220-R222	0062-233B3-1XXX	74LS374	1	IC 5A	0986-00803-4600
2	R179, R196	0062-245B3-1XXX	74LS670	2	IC9B, 11B	0986-00803-6300
2	R213, R224	0062-247B3-1XXX	AY-3-8910	2	IC6F, 7F	0986-00803-8500
15	R135, R203-R208, R214-R219, R403, R404	0062-251B3-1XXX	LM3900	1	IC 3D	0986-00803-4900
2	R142, R148	0062-275B3-1XXX	MC3403	2	IC10C, 10E	0986-00803-5000
2	R138, R141	0062-287B3-1XXX	MC14016	3	IC7D-9D	0986-00803-6200
4	R144, R145, R149, R150	0062-313B3-1XXX	MC14024	1	IC 12C	0986-00803-7100
2	R152, R154	0062-323B3-1XXX	PROMSB2-A	1	IC 12D	0986-00803-8200
1	RM8	0986-00805-0800	RAM 1K X 8	1	IC 6A	0986-00803-8000
1	RM9	0986-00805-0600	ROM/EPROM 0	1	IC 7A	0A27-00803-0024
4	RM2-RM5	0986-00805-0500	ROM/EPROM 1	1	IC 8A	0A27-00803-0025
1	RM7	0986-00805-0400	ROM/EPROM 2	1	IC 9A	NOT USED
2	RM1, RM14	0986-00805-0300	ROM/EPROM 3	1	IC 10A	NOT USED
			Z-80(3880)	1	IC 12A	0986-00803-5500
			16 PIN IC SOCKET	1	ICS 12D	0986-00804-1400
			24 PIN IC SOCKET	5	ICS6A-ICS10A	0986-00804-1600
			40 PIN IC SOCKET	3	ICS12A, ICS6F, ICS7F	0986-00804-1500
			9 PIN KK 100 RT. ANGLE OMIT 4	1	J3	3000-16366-0901
			10 PIN KK 100 RT. ANGLE OMIT 8	1	J6	3000-16366-1001
			19 PIN KK 100 RT. ANGLE OMIT 14	1	J4	3000-16366-1901
			23 PIN KK 100 RT. ANGLE OMIT 19	1	J5	3000-16366-2301
			24 PIN KK 100 RT. ANGLE	2	J1, J2	0986-00804-4700
			JUMPER WIRE	2	JW1, JW2	0986-00804-4000
			YELLOW LED	1	LED 3	0986-00804-2000
			8 POSITION DIP SW.	1	SW3	0986-00805-0900
			10 POSITION DIP SW.	1	SW1	0986-00805-1000
			PB SWITCH	1	SW4	0986-00804-1700
			16 MHZ XTAL W/3RD LEAD	1	XTAL 1	0986-00805-1100
			SNAPS	3	MHQ101-MHQ103	0017-00007-0134
			SUPER SND. I/O BD.	1		A080-90913-6000

PROJECT ENG: C. MEDNICK		USED ON SPY HUNTER UR		Bally / MIDWAY MFG. CO.	
DO NOT SCALE DWG		WEAT TREAT	SCALE FULL	FRANKLIN PK ILL	
DIM TOLERANCES UNLESS SPECIFIED		DRAWN: RLW	NO. REQ'D 1 PER		PART NO M051-00A27 - A011
DATE 11-01-83		SUPER SOUND I/O BD. ASSEMBLY DWG.			
		A084-90913-AA27			

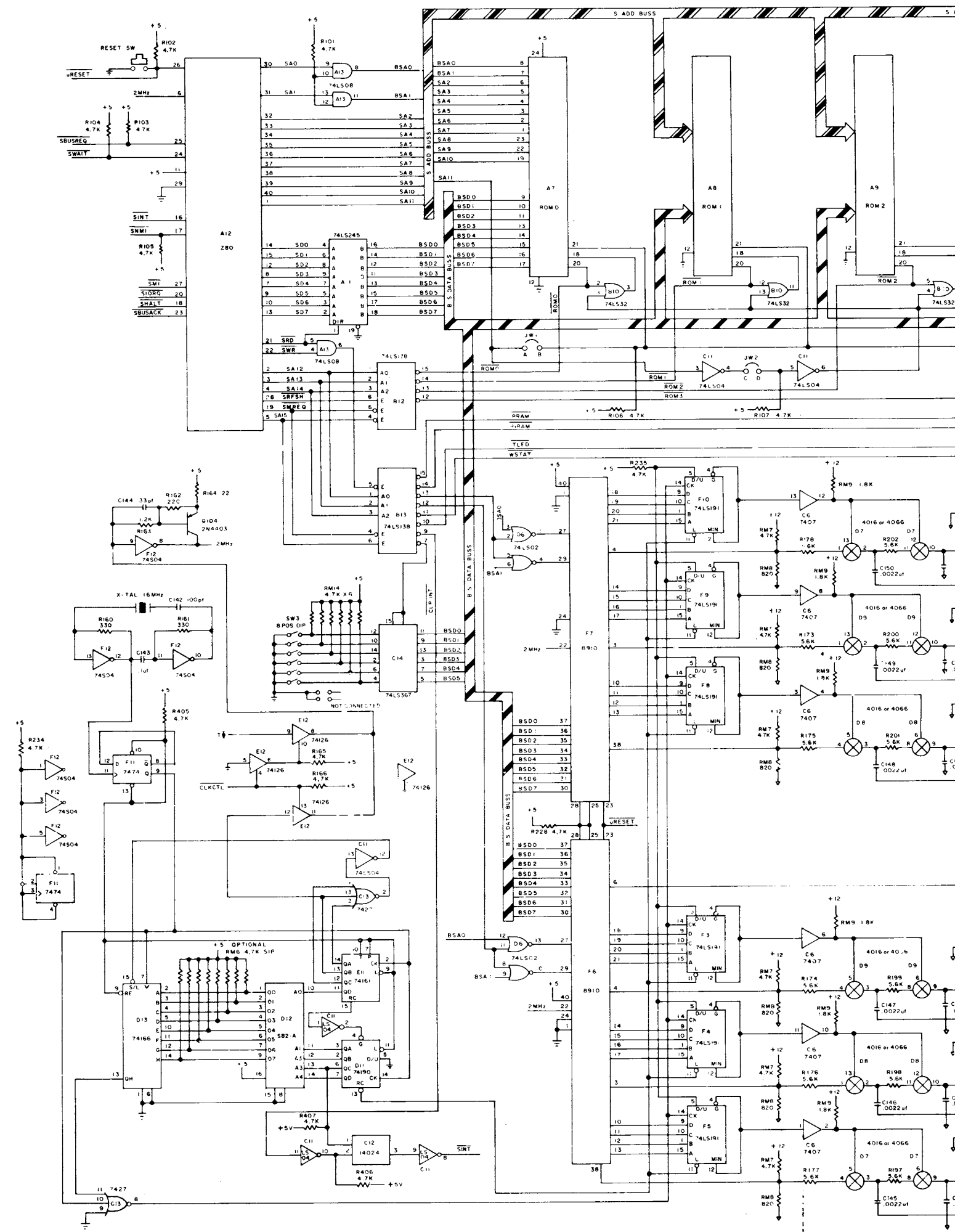

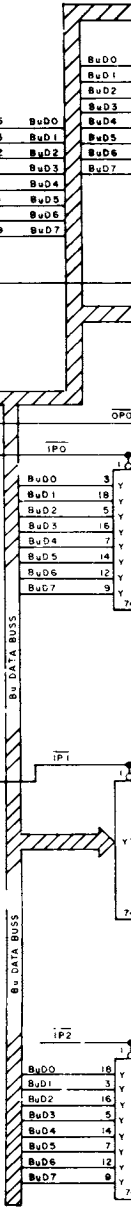
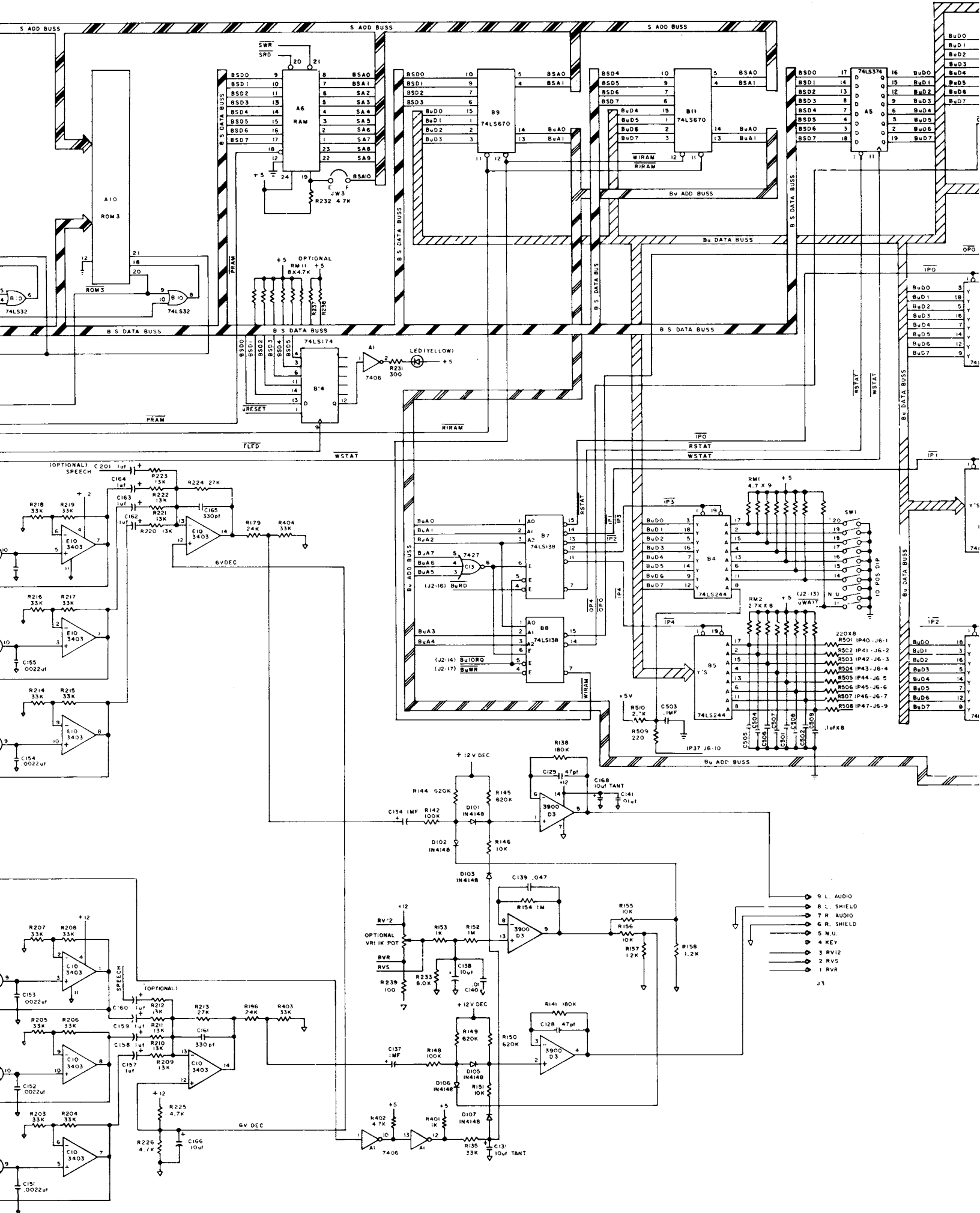

- 9 L. AUDIO
- 8 L. SHIELD
- 7 R. AUDIO
- 6 R. SHIELD
- 5 N.U.
- 4 KEY
- 3 RV12
- 2 RV5
- 1 RVR

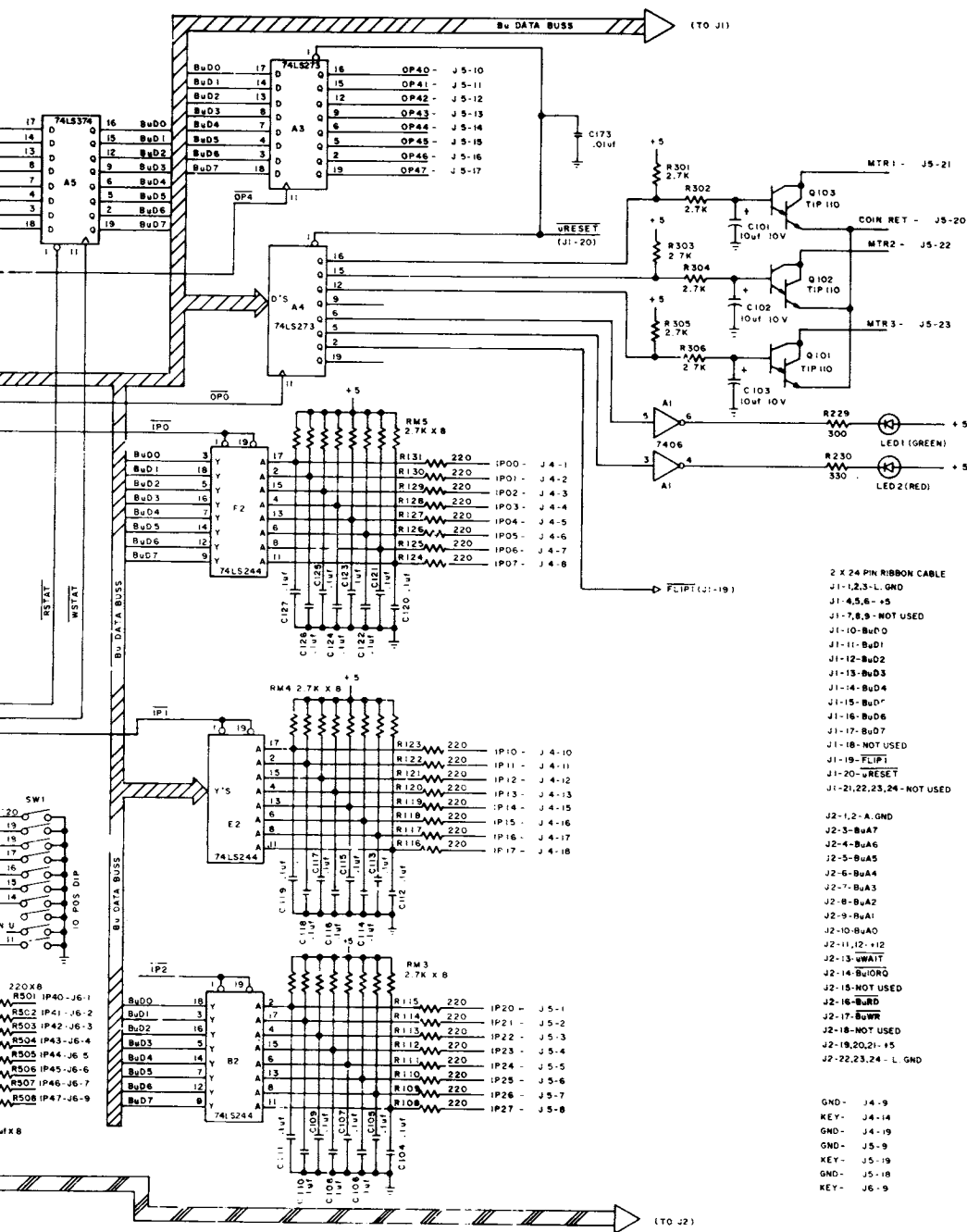

- 2 X 24 PIN RIBBON CABLE
- J1-1,2,3-L GND
 - J1-4,5,6-+5
 - J1-7,8,9-NOT USED
 - J1-10-BuD0
 - J1-11-BuD1
 - J1-12-BuD2
 - J1-13-BuD3
 - J1-14-BuD4
 - J1-15-BuD5
 - J1-16-BuD6
 - J1-17-BuD7
 - J1-18-NOT USED
 - J1-19-FLIPI
 - J1-20-WRESET
 - J1-21,22,23,24-NOT USED
- 72 PIN TEST CONN
- 1-L GND
 - 2-+5
 - 3-L GND
 - 4-+5
 - 5-+12
 - 6-A GND
 - 7-+12
 - 8-NCT USED
 - 9-BuD0
 - 10-BuD1
 - 11-BuD2
 - 12-BuD3
 - 13-BuD4
 - 14-BuD5
 - 15-BuD6
 - 16-BuD7
 - 17-SDO
 - 18-SDI
 - 19-SD2
 - 20-SD3
 - 21-SD4
 - 22-SD5
 - 23-SD6
 - 24-SD7
 - 25-BuA0
 - 26-BuA1
 - 27-BuA2
 - 28-BuA3
 - 29-BuA4
 - 30-BuA5
 - 31-BuA6
 - 32-BuA7
 - 33-SA0
 - 34-SA1
 - 35-SA2
 - 36-SA3
 - 37-SA4
 - 38-SA5
 - 39-SA6
 - 40-SA7
 - 41-SA8
 - 42-SA9
 - 43-SA10
 - 44-SA11
 - 45-SA12
 - 46-SA13
 - 47-SA14
 - 48-SA15
 - 49-SM1
 - 50-SM2
 - 51-SM3
 - 52-SBUSACK
 - 53-SWRD
 - 54-SWR
 - 55-WRESET
 - 56-TS
 - 57-CLKCTL
 - 58-SRD
 - 59-SWR
 - 60-SIORQ
 - 61-BuIORQ
 - 62-SMREQ
 - 63-SBUSREQ
 - 64-SRFSH
 - 65-L GND
 - 66-SWAIT
 - 67-L GND
 - 68-SWALY
 - 69-NOT USED
 - 70-+5
 - 71-L GND
 - 72-+5

- GND- 14-9
- KEY- 14-14
- GND- 14-19
- GND- 15-9
- KEY- 15-19
- GND- 15-18
- KEY- 16-9

W USED ON VERSION W/PANNING
 NOT USED ON VERSION W/PANNING

*W NOT USED ON VERSION W/PANNING
 USED ON VERSION W/PANNING

NOTE

ROM JUMPER OPTIONS	JW1	JW2
2732 COMPATABILITY	X	X
2732 COMPATABILITY	X	X

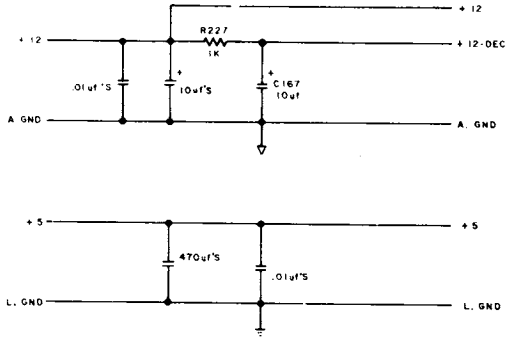

AUDIO SHIELD
 AUDIO SHIELD
 U
 Y
 /12
 /5
 /R

PROJECT ENG J. JARON		USED ON SPY HUNTER		REVISED	
DATE	REV	NO REVS	I PER	Bally / MIDWAY MFG. CO.	
09/08/83	1			FRANKLIN PA. U.S.A.	
SCHEMATIC DRAWING			PART NO		
SUPER SOUND I/O			M051-00986-G016		
A084-90913-G000					

DESIGNATION LIST

<u>DESIGNATION NO.</u>	<u>DESCRIPTION</u>	<u>DESIGNATION NO.</u>	<u>DESCRIPTION</u>
C1,C2	390 PF AX CER	R122	2.7K OHM 1/4W CRBN
C3-C5	100 PF AX CER	R123,R124	360 OHM 1/4W CRBN
C6,C7	820 PF AX CER	R125	180 OHM 1/4W CRBN
C8-C11	100 PF AX CER	R126	2.7K OHM 1/4W CRBN
C101,C102	390 PF AX CER	R127	560K OHM 1/4W CRBN
C103	1 MF RD TANT		
C104	.01 MF AX CER	D1-D4	1N5817
C105	47 MF AX ELECT		
C106	680 PF AX CER	Q1-Q3	2N5305
C107	.01 MF AX CER		
C108	1 MF RD TANT	U1	MC3340
C109	68 PF AX CER 10%	U2,U3	LM359
C110	.01 MF AX CER	U4	74S74
C111	150 PF AX CER 10%	U5	68000-8 CPU
C112	470 PF AX CER 10%	U6	2KX8 RAM
C113	270 PF AX CER 10%	U7	EPRUM
C114	1 MF RD TANT	U8	EPRUM
C115	5600 PF AX CER 10%	U9	6821 PIA
C116	.01 MF AX CER	U10	AD7533JN DAC
C117	1 MF RD TANT	U11	MC14584/40106
C118	270 PF AX CER	U12	74LS74
C119	10 MF RD TANT	U13	74LS04
C120	.01 MF AX CER	U14	74F32/74S32
C121	10 MF RD TANT	U15	CSD002RO PAL
C122	47 MF AX ELECT	U16	2KX8 RAM 250NS
		U17	EPRUM
		U18	EPRUM
CP1-CP13	.01MF AX CER	FB1,FB2	FERRITE BEAD
CP14,CP15	10 MF AX TANT	FB101,FB102	FERRITE BEAD
CP16	100 MF AX ELECT		
R1-R3	4.7K OHM 1/4W CRBN	ICS U5	64 PIN IC SOCKET
R4	10K OHM 1/4W CRBN	ICS U6	24 PIN IC SOCKET
R5	100K OHM 1/4W CRBN	ICS U7,U8	28 PIN IC SOCKET
R6-R9	4.7K OHM 1/4W CRBN	ICS U9	40 PIN IC SOCKET
R10	1K OHM 1/4W CRBN	ICS U10	16 PIN IC SOCKET
R11-R14	4.7K OHM 1/4W CRBN	ICS U15	8 PIN IC SOCKET
R15,R16	10K OHM 1/4W CRBN	ICS U15A	16 PIN IC SOCKET
R17,R18	100 OHM 1/4W CRBN	ICS U16	24 PIN IC SOCKET
R19-R21	10K OHM 1/4W CRBN	ICS U17,U18	28 PIN IC SOCKET
R22	100K OHM 1/4W CRBN		
R23	10K OHM 1/4W CRBN	J1	AUTO INSERT PINS TIN .025 SQ. PIN
R24	100K OHM 1/4W CRBN	J2	AUTO INSERT PINS TIN .045 SQ. PIN
R25	100 OHM 1/4W CRBN	J3	AUTO INSERT PINS TIN .025 SQ. PIN
R26	47K OHM 1/4W CRBN		
R101	24K OHM 1/4W CRBN	JW1-JW3	ZERO OHM RESISTOR
R102	160K OHM 1/4W CRBN		
R103	100 OHM 1/4W CRBN	LED 1	GREEN LED
R104	330K OHM 1/4W CRBN		
R105	24K OHM 1/4W CRBN	SW1	SWITCH PC MOUNT
R106	3.3K OHM 1/4W CRBN		
R107	24K OHM 1/4W CRBN	Y1	16 MHZ XSTAC OSC
R108	150K OHM 1/4W CRBN		
R109	82K OHM 1/4W CRBN	MH1-MH4	1/4" SPACER FOR #8 SCREW
R110	510K OHM 1/4W CRBN		
R111,R112	120K OHM 1/4W CRBN	PC BOARD	A080-91671-D000
R113	33K OHM 1/4W CRBN		
R114	330K OHM 1/4W CRBN		
R115	150K OHM 1/4W CRBN		
R116	33K OHM 1/4W CRBN		
R117	18K OHM 1/4W CRBN		
R118	100K OHM 1/4W CRBN		
R119	510K OHM 1/4W CRBN		
R120	47K OHM 1/4W CRBN		
R121	1K OHM 1/4W CRBN		

+ MHI

© 1983 HUNTLEY ENGINEERING CO.
ALL RIGHTS RESERVED
PAL NUMBER

3



+ MH3

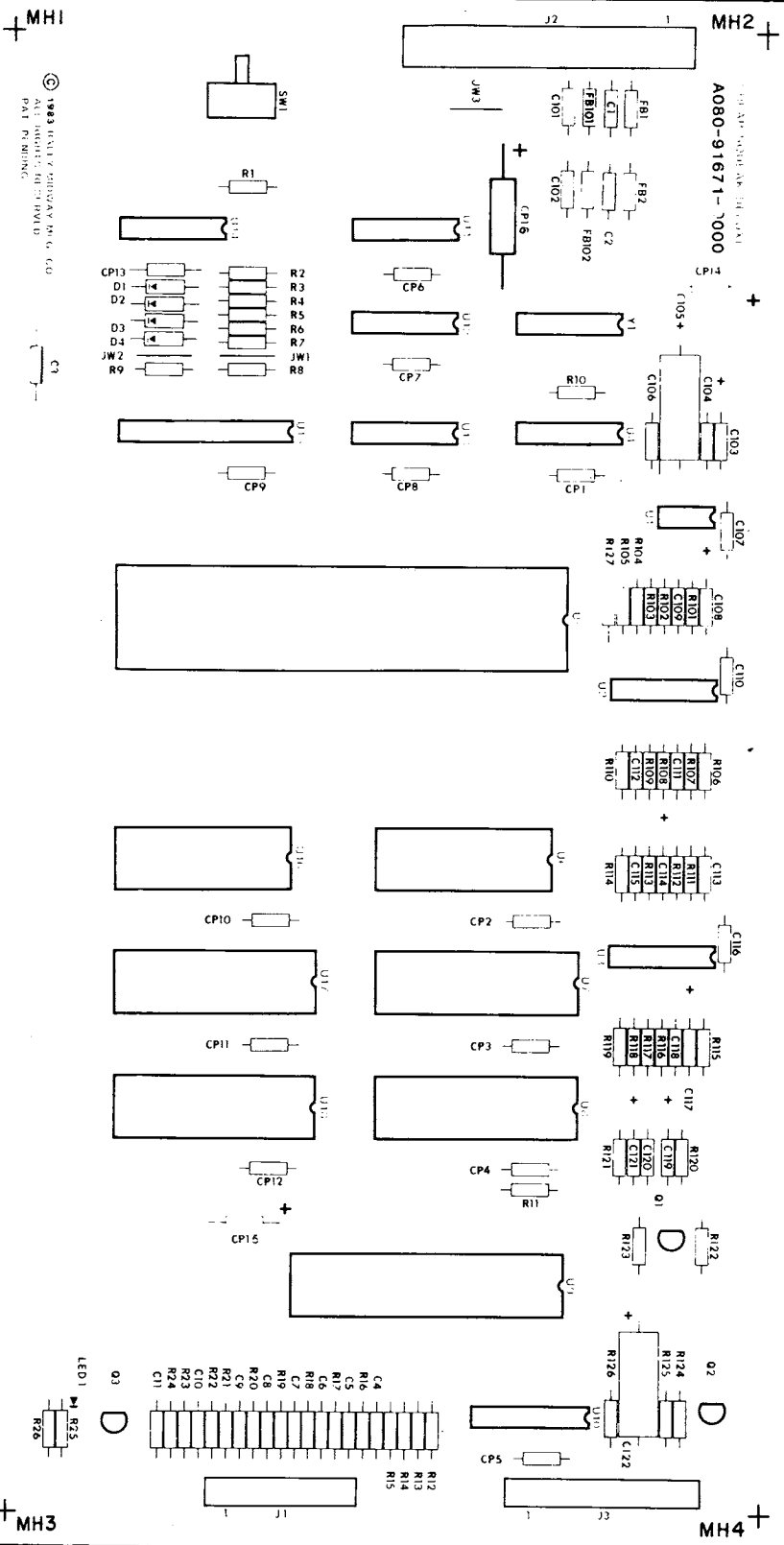

DESCRIPTION	QTY	DESIGNATION NO.
68 PF AX CER 10%	1	C109
100 PF AX CER	7	C3-C5, C8-C11
150 PF AX CER 10%	1	C111
270 PF AX CER 10%	2	C113, C118
390 PF AX CER	4	C1, C2, C101, C102
470 PF AX CER 10%	1	C112
580 PF AX CER	1	C106
820 PF AX CER	2	C6, C7
5600 PF AX CER 10%	1	C115
101 MF AX CER	18	C104, C107, C110, C116, C120, CP1-CP13
1 MF RD TANT	4	C103, C108, C114, C117
10 MF AX TANT	2	CP14, CP15
10 MF RD TANT	2	C119, C121
47 MF AX ELECT	2	C105, C122
100 MF AX ELECT	1	CP16
100 OHM 1/4W CRBN	4	R17, R18, R25, R135
130 OHM 1/4W CRBN	1	R125
360 OHM 1/4W CRBN	2	R123, R124
1K OHM 1/4W CRBN	2	R10, R121
2.7K OHM 1/4W CRBN	2	R122, R126
5.3K OHM 1/4W CRBN	1	R106
4.7K OHM 1/4W CRBN	11	R1-R3, R6-R9, R11-R14
10K OHM 1/4W CRBN	7	R4, R15, R16, R19-R21, R23
18K OHM 1/4W CRBN	1	R117
24K OHM 1/4W CRBN	3	R101, R105, R107
53K OHM 1/4W CRBN	2	R113, R116
47K OHM 1/4W CRBN	2	R26, R120
82K OHM 1/4W CRBN	1	R139
100K OHM 1/4W CRBN	4	R5, R22, R24, R118
120K OHM 1/4W CRBN	2	R111, R112
150K OHM 1/4W CRBN	2	R108, R115
160K OHM 1/4W CRBN	1	R132
330K OHM 1/4W CRBN	2	R104, R114
510K OHM 1/4W CRBN	2	R110, R119
560K OHM 1/4W CRBN	1	R127
1N5817	4	D1-D4
245305	5	Q1-Q3
74LS04	1	U13
74F32/74S32	1	U14
74LS74	1	U12
74S74	1	U4
14584/40106	1	U11
6821 PIA	1	U9
68000-8 CPU	1	U5
AD7533JN	1	U10

PROJECT

0

DESIGN

DATE

BY

REVISION

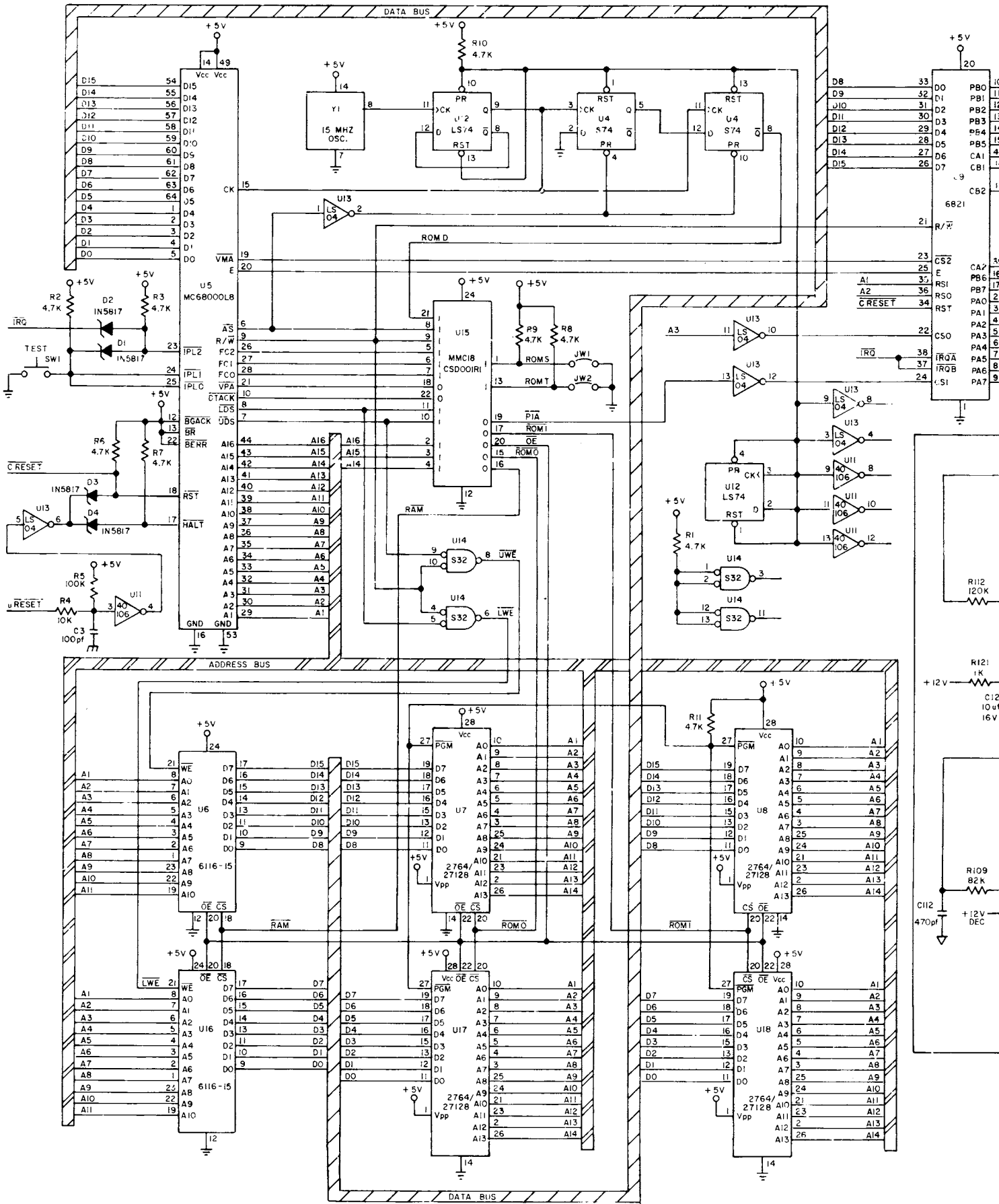

DESIGNATION LIST

<u>DESIGNATION NO.</u>	<u>DESCRIPTION</u>	<u>DESIGNATION NO.</u>	<u>DESCRIPTION</u>	<u>DESIGNATION NO.</u>	<u>DESCRIPTION</u>
C101-C103	10 MF 25V AX. TANT.	R173-R178	5.6K OHM 1/4W 5% CRBN.	IC14C	74LS367
C104-C127	.1 MF 50V AX. CER.	R179	24K OHM 1/4W 5% CRBN.	IC3D	LM3900
C128,C129	47 PF 50V AX. CER.	R180-R186	4.7K OHM 1/4W 5% CRBN.	IC5D	MC14051
C131	10 MF 25V AX. TANT.	R187,R188	24K OHM 1/4W 5% CRBN.	IC6D	74LS02
C134-C137	1 MF 20V AX. TANT.	R189-R195	4.7K OHM 1/4W 5% CRBN.	IC7D-9D	MC14016
C138	10 MF 25V AX. TANT.	R196	24K OHM 1/4W 5% CRBN.	IC11D	74190
C139	.047 MF 100V MYLAR	R197-R202	5.6K OHM 1/4W 5% CRBN.	IC12D	PROMSB2A
C140,C141	.01 MF 50V AX. CER.	R203-R208	33K OHM 1/4W 5% CRBN.	IC13D	74166
C142	100 PF 50V AX. CER.	R209-R211	13K OHM 1/4W 5% CRBN.	IC2E	74LS244
C143	.1 MF 50V AX. CER.	R213	27K OHM 1/4W 5% CRBN.	IC3E	MC14051
C144	33 PF 50V AX. CER.	R214-R219	33K OHM 1/4W 5% CRBN.	IC5E	7407
C145-C156	.0022 MF 100V 10% MYLAR	R220-R222	13K OHM 1/4W 5% CRBN.	IC10E	MC3403
C157-C155	1 MF 20V AX. TANT.	R224	27K OHM 1/4W 5% CRBN.	IC11E	74161
C161	330 PF 50V AX. CER.	R225,R226	4.7K OHM 1/4W 5% CRBN.	IC12E	74126
C162-C164	1 MF 20V AX. TANT.	R227	1K OHM 1/4W 5% CRBN.	IC2F	74LS244
C165	330 PF 50V AX. CER.	R228	4.7K OHM 1/4W 5% CRBN.	IC3F-5F	74LS191
C166-C168	10 MF 25V AX. TANT.	R231	300 OHM 1/4W 5% CRBN.	IC6F,7F	AY-3-8910
C172	10 MF 25V AX. TANT.	R232	4.7K OHM 1/4W 5% CRBN.	IC8F-10F	74LS191
C173	.01 MF 50V AX. CER.	R233	3K OHM 1/4W 5% CRBN.	IC11F	7474
CP1	470 MF 16V AX. ELECT.	R234,R235	4.7K OHM 1/4W 5% CRBN.	IC12F	74S04
CP2-CP12	.01 MF 50V AX. CER.	R239	100 OHM 1/4W 5% CRBN.	ICS6A-ICS10A	24 PIN IC SOCKE
CP13	470 MF 16V AX. ELECT.	R301-R306	2.7K OHM 1/4W 5% CRBN.	ICS12A	40 PIN IC SOCKE
CP14-CP33	.01 MF 50V AX. CER.	R401	1K OHM 1/4W 5% CRBN.	ICS12D	16 PIN IC SOCKE
CP34	10 MF 25V AX. TANT.	R402	4.7K OHM 1/4W 5% CRBN.	ICS6F,7F	40 PIN IC SOCKE
CP35-CP46	.01 MF 50V AX. CER.	R405-R407	4.7K OHM 1/4W 5% CRBN.	J1,J2	24 PIN KK100 R
CP47	470 MF 16V AX. ELECT.	RM1	4.7K OHM 10 PIN S.I.P.	J3	ANGLE
CP48-CP51	.01 MF 50V AX. CER.	RM3-RM5	2.7K OHM 10 PIN S.I.P.	J4	10PIN KK100 RT.
CP52,CP53	10 MF 25V AX. TANT.	RM7	4.7K OHM 8 PIN S.I.P.	J5	ANGLE OMIT 4
CP54	470 MF 16V AX. ELECT.	RM8	820 OHM 8 PIN S.I.P.	JW1,JW2	19 PIN KK100 R
CP201-CP204	10 MF 25V AX. TANT.	RM9	1.8K OHM 10 PIN S.I.P.	LED 3	ANGLE OMIT 14
R101-R107	4.7K OHM 1/4W 5% CRBN.	RM10	22K OHM 10 PIN S.I.P.	SW1	23 PIN KK100 R
R108-R131	220 OHM 1/4W 5% CRBN.	RM14	4.7K OHM 10 PIN S.I.P.	SW3	ANGLE OMIT 19
R135	33K OHM 1/4W 5% CRBN.	D101-D103	1N4148	SW4	JUMPER WIRE
R138,R141	180K OHM 1/4W 5% CRBN.	D105-D107	1N4148	XTAL 1	YELLOW LED
R142,R143	100K OHM 1/4W 5% CRBN.	Q101-Q103	T1P110	MHQ101-MHQ103	10 POSITION DIP
R144,R145	620K OHM 1/4W 5% CRBN.	Q104	2N4403	A080-91657-A000	8 POSITION DIP
R146	10K OHM 1/4W 5% CRBN.	IC1A	7406		PUSHBUTTON S.W.
R147,R148	100K OHM 1/4W 5% CRBN.	IC3A,4A	74LS273		16 MHZ XTAL
R149,R150	620K OHM 1/4W 5% CRBN.	IC5A	74LS374		SNAP
R151	10K OHM 1/4W 5% CRBN.	IC6A	1K X 8 RAM		SOUND I/O BD.
R152	1MEG. OHM 1/4W 5% CRBN.	IC7A	ROM/EPROM 0		
R153	1K OHM 1/4W 5% CRBN.	IC8A	ROM/EPROM 1		
R154	1MEG. OHM 1/4W 5% CRBN.	IC9A	ROM/EPROM 2		
R155,R156	10K OHM 1/4W 5% CRBN.	IC10A	ROM/EPROM 3		
R157,R158	1.2K OHM 1/4W 5% CRBN.	IC11A	74LS245		
R160,R161	330 OHM 1/4W 5% CRBN.	IC12A	Z-80 CPU		
R162	220 OHM 1/4W 5% CRBN.	IC13A	74LS08		
R163	1.2K OHM 1/4W 5% CRBN.	IC2B,4B	74LS244		
R164	22 OHM 1/4W 5% CRBN.	IC7B,8B	74LS138		
R165,R166	4.7K OHM 1/4W 5% CRBN.	IC9B	74LS670		
		IC10B	74LS32		
		IC11B	74LS670		
		IC12B,13B	74LS138		
		IC14B	74LS174		
		IC6C	7407		
		IC10C	MC3403		
		IC11C	74LS04		
		IC12C	MC14024		
		IC13C	7427		

PROJECT ENG: C. MEI	
DONOR: ALL BY	
DIM TOLERANCE	DRW.
DATE	DATE

DESCRIPTION

4LS367
M3900
C14051
4LS02
C14016
4190
ROMSB2A
4166
4LS244
C14051
407
C3403
4161
4126
4LS244
4LS191
-3-8910
4LS191
474
4S04

4 PIN IC SOCKET
D PIN IC SOCKET
5 PIN IC SOCKET
D PIN IC SOCKET

4 PIN KK100 RT.
ANGLE
4 PIN KK100 RT.
ANGLE OMIT 4
9 PIN KK100 RT.
ANGLE OMIT 14
5 PIN KK100 RT.
ANGLE OMIT 19

JUMPER WIRE

YELLOW LED

D POSITION DIP
D POSITION DIP
D SWITCH S.W.

4 MHZ XTAL

DIAP

SOUND I/O BD. W/PANNING

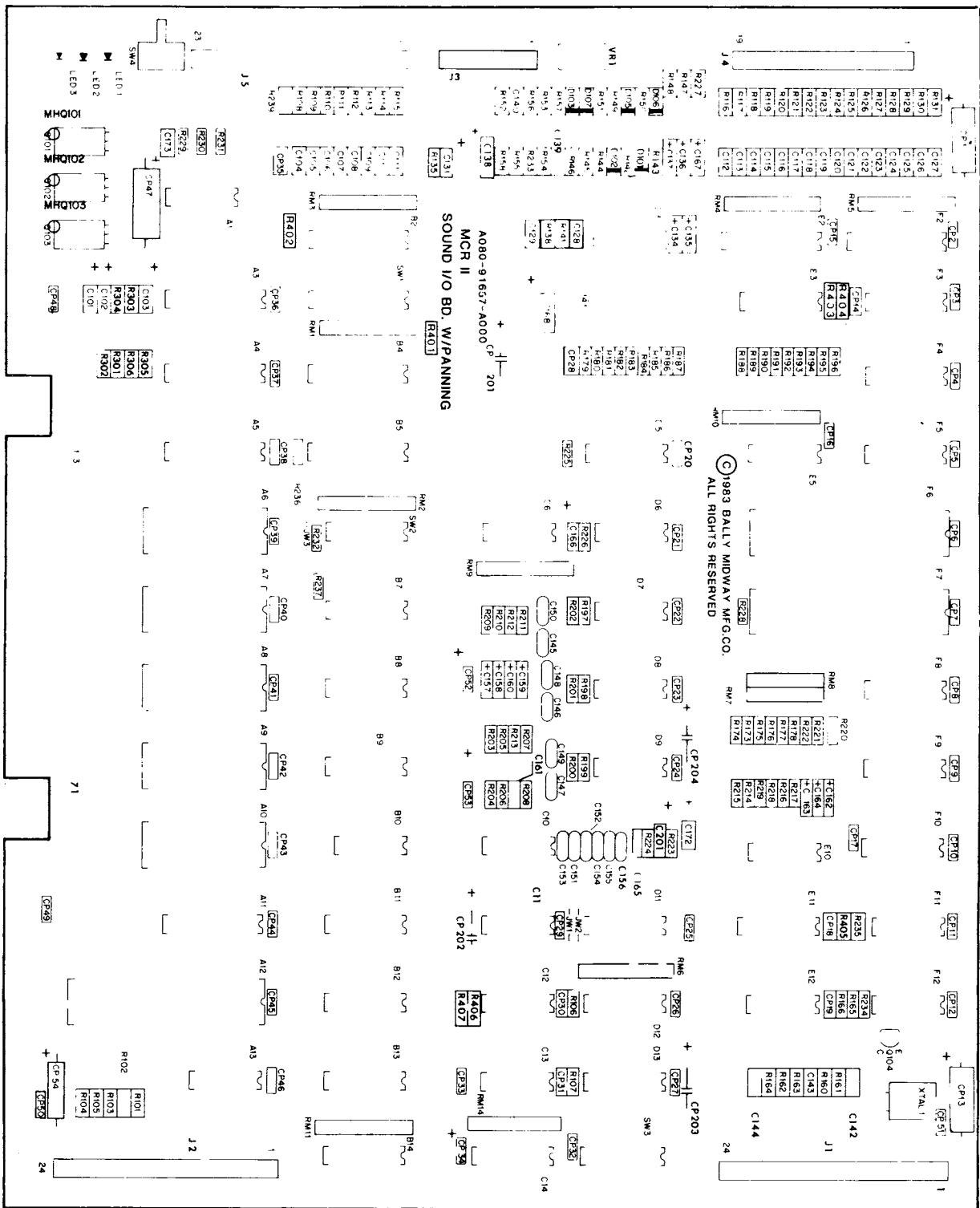

DESCRIPTION

33 PF 50V
CER.
47 PF 50V
CER.
100 PF 50
CER.
330 PF 50
CER.
.0022 MF
MYLAR
.047 MF 1
MYLAR
.01 MF 50
CER.

.1 MF 50V
1 MF 20V

10 MF 25V
TANT.

470 MF 16
ELECT.

22 OHM 1/
CRBN.

100 OHM 1
CRBN.

220 OHM 1
CRBN.

300 OHM 1
CRBN.

330 OHM 1
CRBN.

1K OHM 1/
CRBN.

1.2K OHM
CRBN.

2.7K OHM
CRBN.

3K OHM 1/
CRBN.

4.7K OHM
CRBN.

5.6K OHM
CRBN.

13K OHM 1
CRBN.

13K OHM 1
CRBN.

24K OHM 1
CRBN.

27K OHM 1
CRBN.

33K OHM 1
CRBN.

100K OHM
CRBN.

180K OHM
CRBN.

620K OHM
CRBN.

1 MEG. OH
5% CRBN.

820 OHM 8
S.I.P.

1.8K OHM
S.I.P.

2.7K OHM
S.I.P.

4.7K OHM
S.I.P.

4.7K OHM
S.I.P.

22K OHM 10
S.I.P.

1N4148

DESIGN ENG: C. MEDNICK		USED ON SPY HUNTER SD		Bally / MIDWAY MFG. CO. FRANKLIN PARK, ILL.	
DO NOT SCALE THIS DRAWING	NEAT TREAT	SCALE FULL	NO. REQ'D PER	PART NO	
DRW. R.L.W.	DATE 11/08/83	ASSEMBLY DWG. SOUND I/O BD. W/PANNING A084 - 91657 - A307		M051 - 00307 - A008	

CROSS REFERENCE LIST

DESCRIPTION	QTY	DESIGNATION NO.	PART NOS.	DESCRIPTION	QTY	DESIGNATION NO.	PART NOS.
3 PF 50V 5% AX. ER.	1	C144	0986-00800-0300	2N4403	1	Q104	0986-00802-0500
7 PF 50V AX. ER.	2	C128,C129	0986-00800-2800	T1P110	3	Q101-Q103	0986-00802-0400
00 PF 50V 5% AX. ER.	1	C142	0986-00800-1000	74LS02	1	IC 6D	0986-00803-7400
30 PF 50V AX. ER.	2	C161,C165	0986-00800-1300	74LS04	1	IC 11C	0986-00803-6900
0022 MF 100V 10% IYLAR	12	C145-C156	0986-00800-1200	74S04	1	IC 12F	0986-00803-6600
047 MF 100V IYLAR	1	C139	0986-00800-2600	740C	1	IC 1A	0986-00803-7600
01 MF 50V AX. ER.	50	CP2-CP12,CP14- CP33,CP35-CP46, CP48-CP51,C140, C141,C173	0986-00800-2000	7407	2	IC 5E,6C	0986-00803-5900
1 MF 50V AX. CER.	25	C104-C127,C143	0986-00800-1100	74LS08	1	IC 13A	0986-00803-7300
MF 20V AX. TANT.	10	C134-C137,C157- C159,C162-C164	0986-00800-1400	7427	1	IC 13C	0986-00803-7200
0 MF 25V AX. TANT.	16	CP34,CP52,CP53, CP201-CP204, C101-C103,C131, C138,C166-C168, C172	0986-00800-0700	74LS32	1	IC 10B	0986-00803-6100
70 MF 16V AX. ELECT.	4	CP1,CP13,CP47, CP54	0986-00800-2700	7474	1	IC 11F	0986-00803-6700
22 OHM 1/4W 5% CRBN.	1	R164	0062-063B3-1XXX	74126	4	IC 12E	0986-00803-6800
100 OHM 1/4W 5% CRBN.	1	R239	0062-110B3-1XXX	74LS138	1	IC 7B,8B,12B, 13B	0986-00803-6500
220 OHM 1/4W 5% CRBN.	25	R108-R131,R162	0062-133B3-1XXX	74161	1	IC 11E	0986-00803-5100
600 OHM 1/4W 5% CRBN.	1	R231	0062-141B3-1XXX	74166	1	IC 13D	0986-00803-5300
330 OHM 1/4W 5% CRBN.	2	R160,R161	0062-144B3-1XXX	74LS174	1	IC 14B	0986-00803-7500
1K OHM 1/4W 5% CRBN.	3	R153,R227,R401	0062-179B3-1XXX	74190	1	IC 11D	0986-00803-9400
1.2K OHM 1/4W 5% CRBN.	3	R157,R158,R163	0062-183B3-1XXX	74LS191	6	IC 3F-5F,8F- 10F	0986-00803-5600
2.7K OHM 1/4W 5% CRBN.	6	R301-R306	0062-199B3-1XXX	74LS244	4	IC 2B,4B,2E, 2F	0986-00803-4800
5K OHM 1/4W 5% CRBN.	1	R233	0062-201B3-1XXX	74LS245	1	IC 11A	0986-00803-6400
4.7K OHM 1/4W 5% CRBN.	33	R101-R107,R165, R166,R180-R186, R189-R195,R225, R226,R228,R232, R234,R235,R402, R405-R407	0062-211B3-1XXX	74LS273	2	IC 3A,4A	0986-00803-4700
5.6K OHM 1/4W 5% CRBN.	12	R173-R178,R197- R202	0062-215B3-1XXX	74LS367	1	IC 14C	0986-00803-7000
10K OHM 1/4W 5% CRBN.	4	R146,R151,R155, R156	0062-227B3-1XXX	74LS374	1	IC 5A	0986-00803-4600
13K OHM 1/4W 5% CRBN.	6	R209-R211,R220- R222	0062-233B3-1XXX	74LS670	2	IC 9B,11B	0986-00803-6300
24K OHM 1/4W 5% CRBN.	4	R179,R187,R188, R196	0062-245B3-1XXX	AY-3-8910	2	IC 6F,7F	0986-00803-8500
27K OHM 1/4W 5% CRBN.	2	R213,R224	0062-247B3-1XXX	LM3900	1	IC 3D	0986-00803-4900
33K OHM 1/4W 5% CRBN.	13	R135,R203-R208, R214-R219	0062-251B3-1XXX	MC3403	2	IC 10C,10E	0986-00803-5000
100K OHM 1/4W 5% CRBN.	4	R142,R143,R147, R148	0062-275B3-1XXX	MC14016	3	IC 7D-9D	0986-00803-6200
180K OHM 1/4W 5% CRBN.	2	R138,R141	0062-287B3-1XXX	MC14024	1	IC 12C	0986-00803-7100
220K OHM 1/4W 5% CRBN.	4	R144,R145,R149, R150	0062-313B3-1XXX	MC14051	2	IC 3E,5D	0986-00803-5400
1 MEG. OHM 1/4W 5% CRBN.	2	R152,R154	0062-323B3-1XXX	PROMSB2-A	1	IC 12D	0986-00803-8200
320 OHM 8 PIN S.I.P.	1	RM8	0986-00805-0800	RAM 1K X 8	1	IC 6A	0986-00803-8000
1.8K OHM 10 PIN S.I.P.	1	RM9	0986-00805-0600	ROM/EPROM 0	1	IC 7A	0307-00803-0006
2.7K OHM 10 PIN S.I.P.	3	RM3-RM5	0986-00805-0500	ROM/EPROM 1	1	IC 8A	0986-00803-0007
4.7K OHM 8 PIN S.I.P.	1	RM7	0986-00805-0400	ROM/EPROM 2	1	IC 9A	NOT USED
4.7K OHM 10 PIN S.I.P.	2	RM1,RM14	0986-00805-0300	ROM/EPROM 3	1	IC 10A	NOT USED
22K OHM 10 PIN S.I.P.	1	RM10	0986-00805-0700	Z-80(3880)	1	IC 12A	0986-00803-5500
MN4148	6	D101-D103,D105- D107	0986-00801-0200	16 PIN IC SOCKET	1	ICS 12D	0986-00804-1400
				24 PIN IC SOCKET	5	ICS 6A-ICS 10A	0986-00804-1600
				40 PIN IC SOCKET	3	ICS 12A,ICS 6F, ICS 7F	0986-00804-1500
				10 PIN KK 100 RT. ANGLE OMIT 4	1	J3	3000-16366-1002
				19 PIN KK 100 RT. ANGLE OMIT 14	1	J4	3000-16366-1901
				23 PIN KK 100 RT. ANGLE OMIT 19	1	J5	3000-16366-2301
				24 PIN KK 100 RT. ANGLE	2	J1,J2	0986-00804-4700
				JUMPER WIRE	2	JW1,JW2	0986-00804-4000
				YELLOW LED	1	LED 3	0986-00804-2000
				8 POSITION DIP SW.	1	SW3	0986-00805-0900
				10 POSITION DIP SW.	1	SW1	0986-00805-1000
				PB SWITCH	1	SW4	0986-00804-1700
				16 MHZ XTAL W/3RD LEAD	1	XTAL 1	0986-00805-1100
				SNAPS	3	MHQ101-MHQ103	0017-00007-0134
				SOUND I/O BD. W/PANNING	1		A080-91657-A000

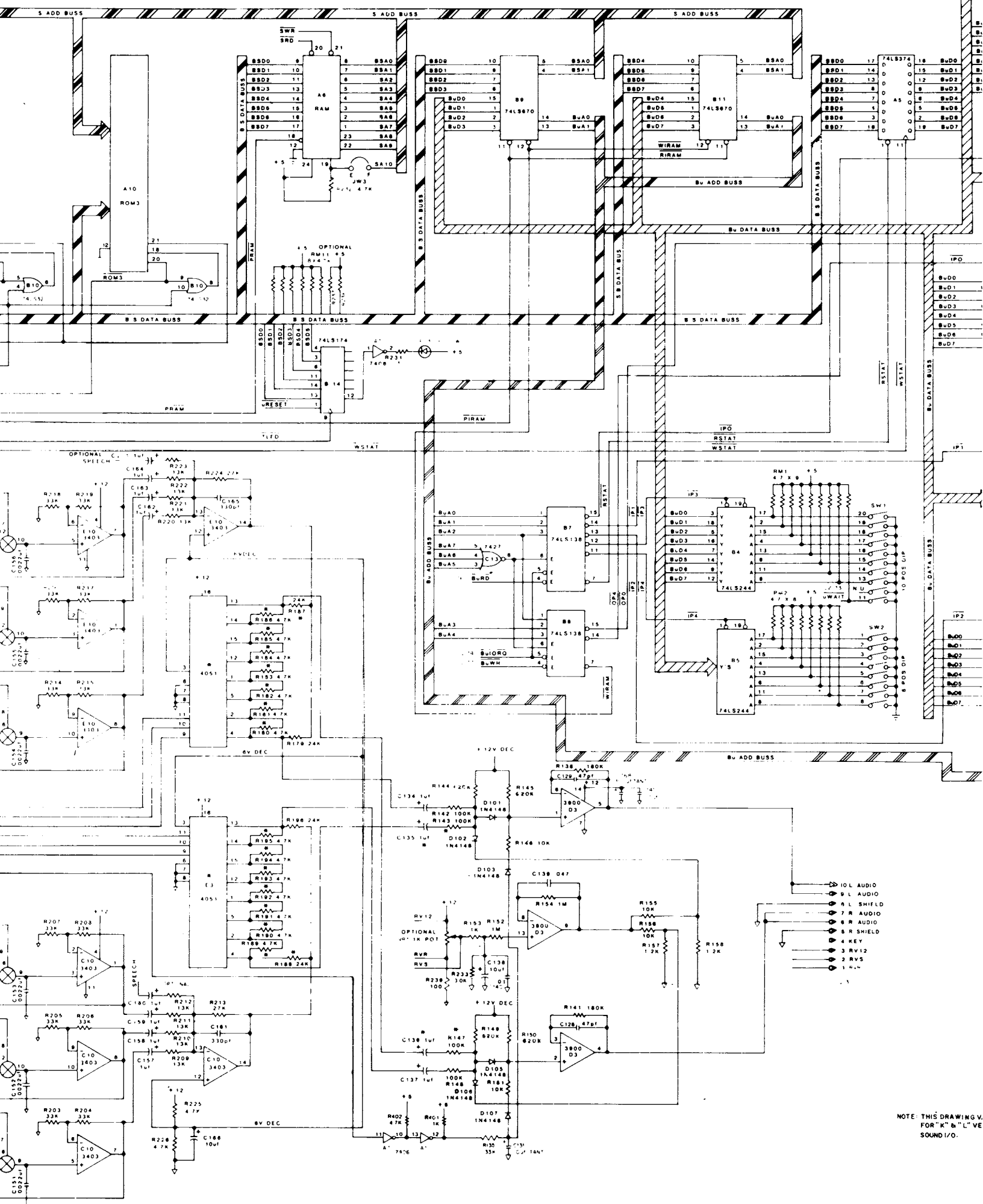

NOTE: THIS DRAWING V.
FOR "K" & "L" VE
SOUND I/O.

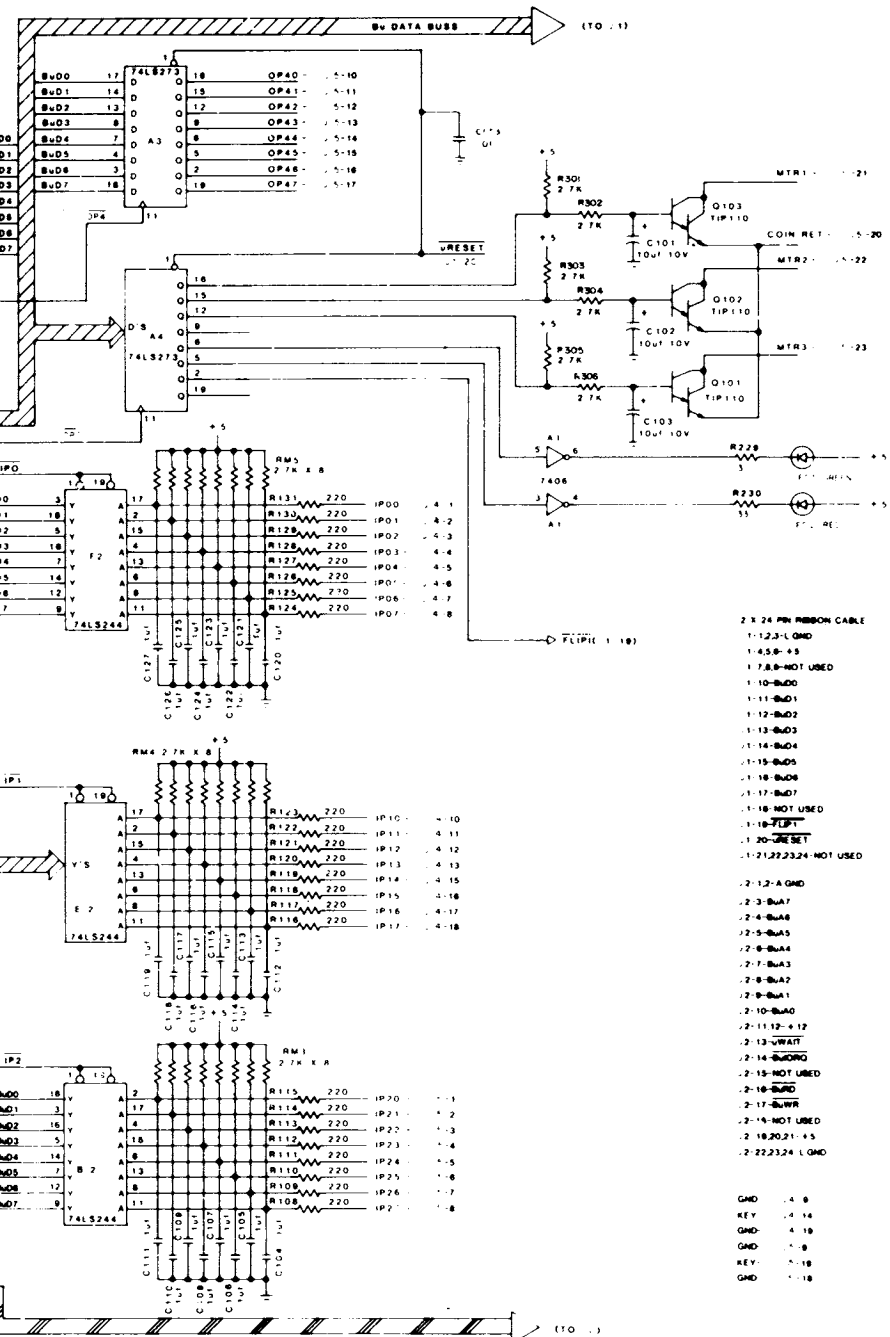

- 2 8 24 PIN RIBBON CABLE
- 1-12,3-L GND
 - 1-4,5-B +5
 - 1-7,8-NOT USED
 - 1-10-BU00
 - 1-11-BU01
 - 1-12-BU02
 - 1-13-BU03
 - 1-14-BU04
 - 1-15-BU05
 - 1-16-BU06
 - 1-17-BU07
 - 1-18-NOT USED
 - 1-19-F1P1
 - 1-20-VRESET
 - 1-21,22,23,24-NOT USED
 - 2-1,2-A GND
 - 2-3-BU07
 - 2-4-BU08
 - 2-5-BU09
 - 2-6-BU10
 - 2-7-BU11
 - 2-8-BU12
 - 2-9-BU13
 - 2-10-BU14
 - 2-11,12-BU15
 - 2-13-WAIT
 - 2-14-BU16
 - 2-15-NOT USED
 - 2-16-BU17
 - 2-17-BU18
 - 2-18-NOT USED
 - 2-19,20,21-BU19
 - 2-22,23,24-L GND
 - GND - 4, 6
 - KEY - 4, 14
 - GND - 4, 16
 - KEY - 4, 8
 - KEY - 4, 18
 - GND - 4, 18

- 72 PIN TEST CONN
- 1 - JNT
 - 2 +5
 - 3 - JNT
 - 4 +5
 - 5 +12
 - 6 - JNT
 - 7 +12
 - 8 - NOT USED
 - 9-BU00
 - 10-BU01
 - 11-BU02
 - 12-BU03
 - 13-BU04
 - 14-BU05
 - 15-BU06
 - 16-BU07
 - 17-S00
 - 18-S01
 - 19-S02
 - 20-S03
 - 21-S04
 - 22-S05
 - 23-S06
 - 24-S07
 - 25-BU08
 - 26-BU09
 - 27-BU10
 - 28-BU11
 - 29-BU12
 - 30-BU13
 - 31-BU14
 - 32-BU15
 - 33-SA0
 - 34-SA1
 - 35-SA2
 - 36-SA3
 - 37-SA4
 - 38-SA5
 - 39-SA6
 - 40-SA7
 - 41-SA8
 - 42-SA9
 - 43-SA10
 - 44-SA11
 - 45-SA12
 - 46-SA13
 - 47-SA14
 - 48-SA15
 - 49-SB0
 - 50-SB1
 - 51-SB2
 - 52-SB3BACK
 - 53-BU16
 - 54-BU17
 - 55-VRESET
 - 56-T8
 - 57-CLKCTL
 - 58-BRD
 - 59-SWR
 - 60-SORG
 - 61-BU18
 - 62-SB16
 - 63-SB16EO
 - 64-SB16H
 - 65-L GND
 - 66-SWAT
 - 67-L GND
 - 68-SHALT
 - 69-NOT USED
 - 70-BU19
 - 71-JNT
 - 72-BU19

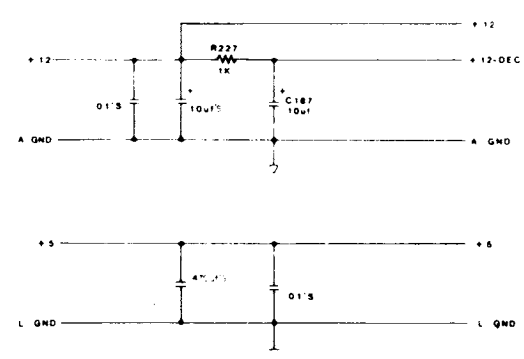

NOTE
 R W JUMPER OPTONS
 EPROM ROM
 2532 COMPATBLTY
 2732 COMPATBLTY

DRAWING VALID & "L" VERSION 1/0.

PROJ ENG CARY MEDNICK

DISCS OF TRON

MIDWAY MFG. CO.

FULL SCHEMATIC SOUND I/O W/ PANNING A084-91657-A000

MO51-00982-A035

08/11/83

DESIGNATION LIST

<u>DESIGNATION NO.</u>	<u>DESCRIPTION</u>
C1-C4	100 PF 50V AX CER
C5	.01 UF 50V AX CER
C6	100 PF 50V AX CER
C7	10 UF 16V AX ELECT
C8	4700 UF 25V AX ELECT
C9, C10	.01 UF 50V AX CER
R1	10K OHM 1/4W 5%
R2	100K OHM 1/4W 5%
R3	10K OHM 1/4W 5%
R4	100K OHM 1/4W 5%
R5	10K OHM 1/4W 5%
R6	100K OHM 1/4W 5%
R7	10K OHM 1/4W 5%
R8	100K OHM 1/4W 5%
R9	10K OHM 1/4W 5%
R10	100K OHM 1/4W 5%
R11-R18	100K OHM 1/4W 5%
R19	2.2 OHM 1W 5%
U1	4099
U2, U3	2068B
J1	.025 SQ PIN
J2	.045 SQ PIN
PCMH1-PCMH4	SPACER #8
P.C. BOARD	A080-91673-A000

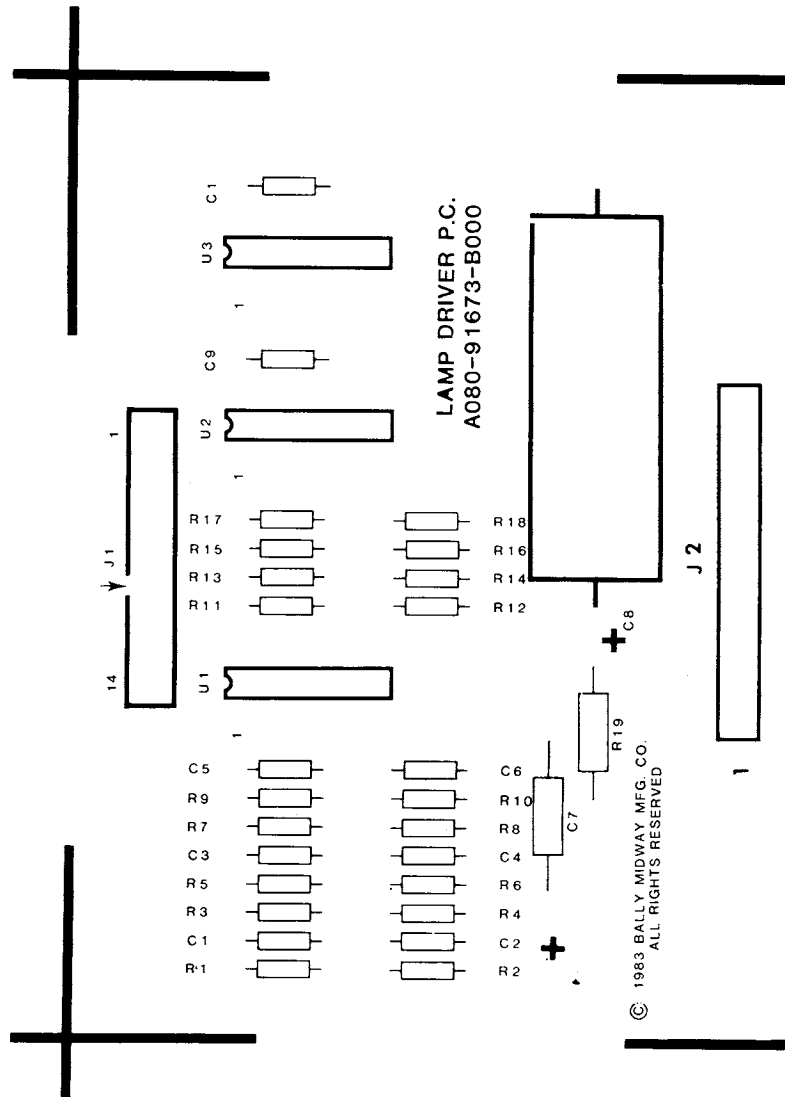

PROJECT ENG. J. BOYDSTON

DATE: 10/28/83

DRM

CKD.

DATE

10/28/83

CROSS REFERENCE LIST

<u>DESCRIPTION</u>	<u>QTY</u>	<u>DESIGNATION NO.</u>	<u>PART NOS.</u>
100 PF 50V AX CER	5	C1-C4,C6	0639-00800-0003
.01 UF 50V AX CER	3	C5,C9,C10	0628-00800-0100
10 MF 16V AX ELECT	1	C7	0628-00800-0300
4700 UF 25V AX ELECT	1	C8	0383-00800-0006
2.2 OHM 1W 5%	1	R19	100E-00007-0003
10K OHM 1/4W 5%	5	R1,R3,R5,R7,R9	100E-00005-0088
100K OHM 1/4W 5%	13	R2,R4,R6,R8,R10 R11-R18	100E-00005-0115
2068B	2	U2,U3	0307-00803-0003
4099	1	U1	0307-00803-0004
.025 SQ PIN	13	J1	0017-00033-0479
.045 SQ PIN	10	J2	0017-00033-0480
SPACER #8	4	PCMH1-PCMH4	0017-00042-0320
P.C. BOARD	1		A080-91673-A000

REVISIONS	

ON		USED ON		<i>Balt</i> / MIDWAY MFG. CO. FRANKLIN PK ILL
HEAT TREAT	SCALE	FULL	NO REQ'D I PER	
MAT'L	ASSEMBLY DWG		PART NO.	
FINISH	LAMP DRIVER P.C.		M051 - 00114 - B094	
8/33	A080-91673-B000			

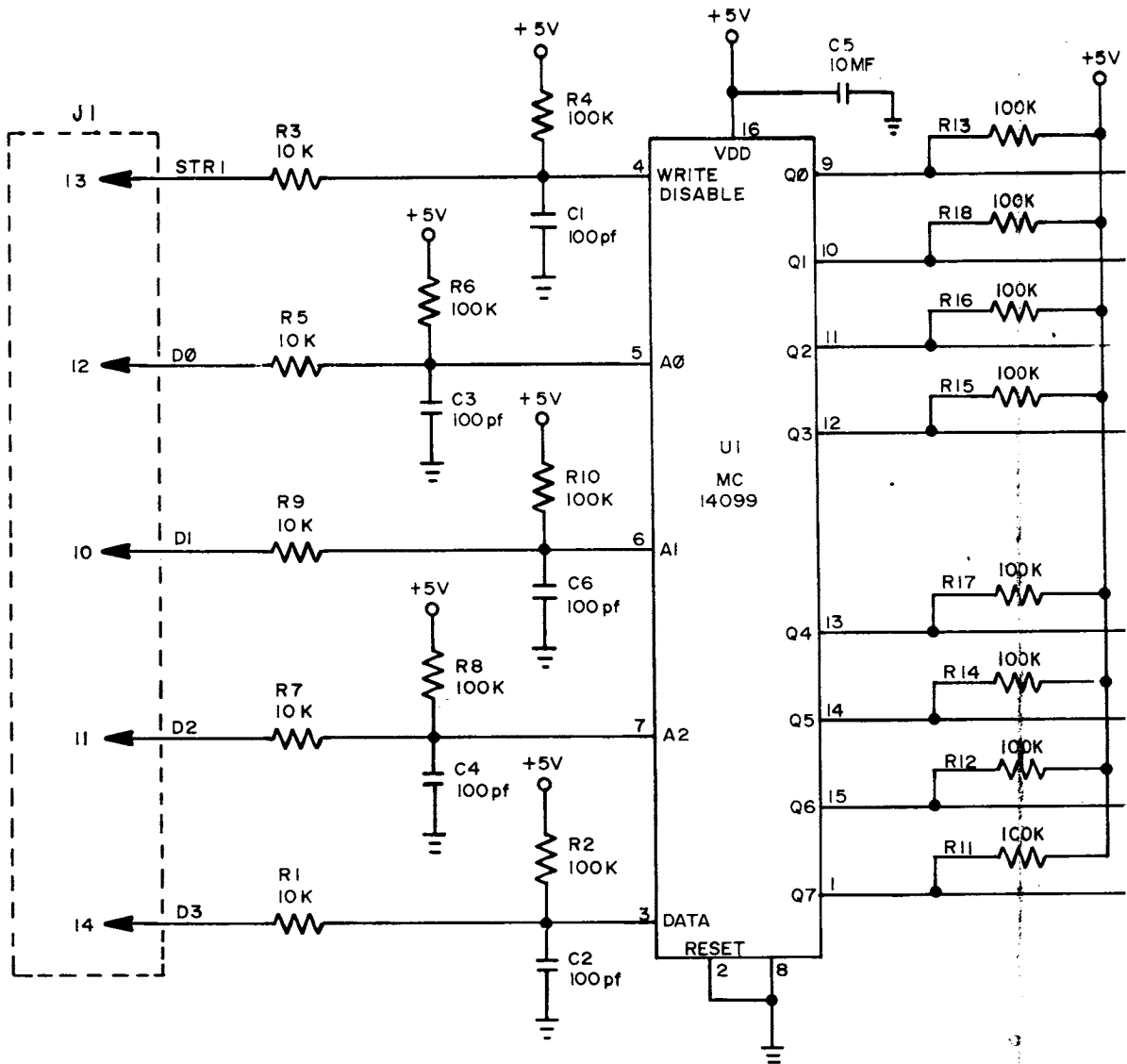

PROJECT ENG: J. BO	
DO NOT SCALE D.V.	
DIM TOLERANCES UNLESS SPECIFIED	DWG.
UNLESS OTHERWISE SPECIFIED	CAD.
FRACTIONAL	1/16
DECIMAL	0.005
HOLE DIA	+0.02 0.00

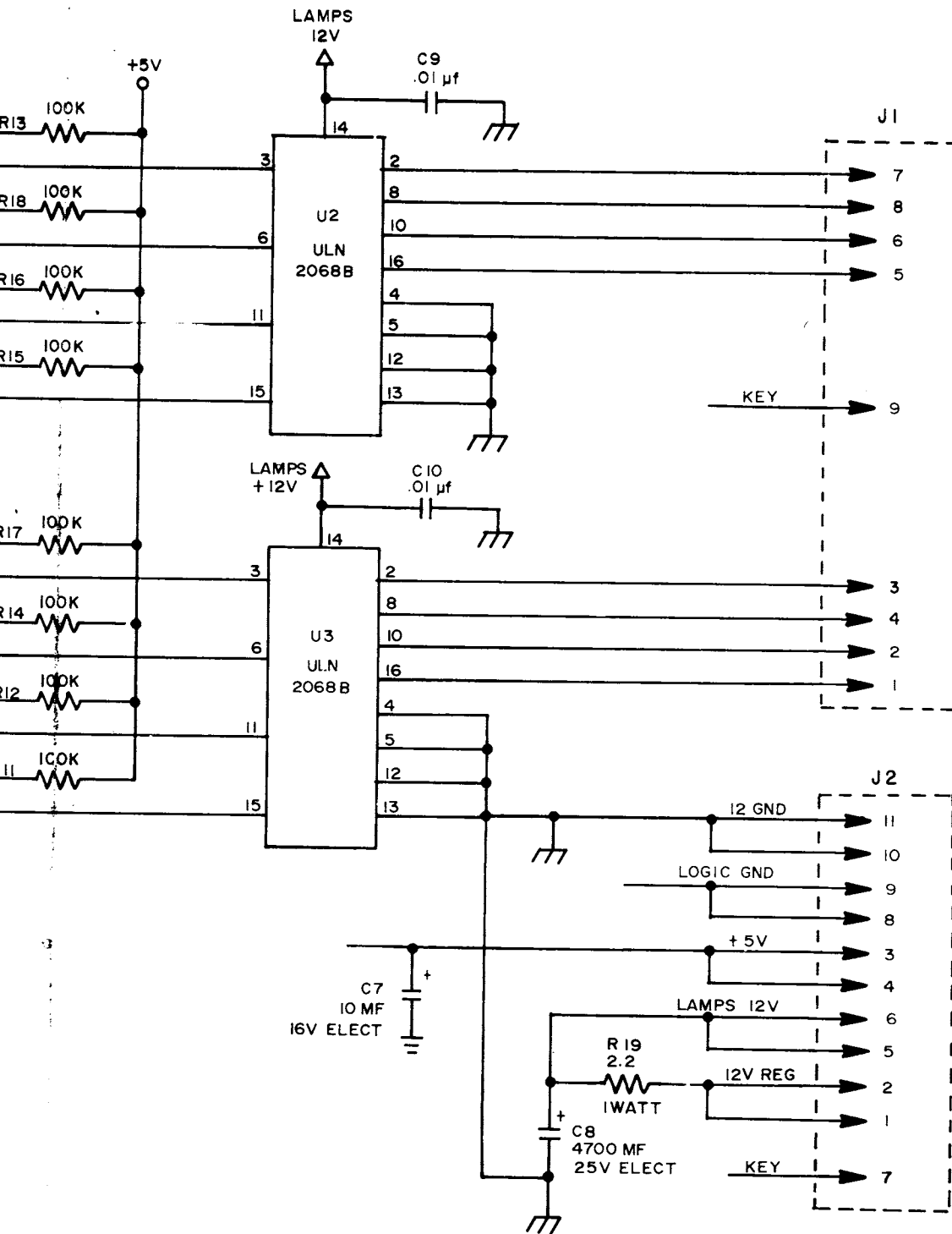

REVISIONS	

DESIGNER: J. BOYDSTON		USED ON		REVISIONS	
DO NOT SCALE DWG		SCALE: FULL		NO. REQ'D PER	
TOLERANCES UNLESS SPECIFIED		MATERIAL		FINISH	
DRAWN: J.B.D.		DATE: 10/27/83		PART NO. M051 - 00114 - B095	
SCHEMATIC DWG LAMP DRIVER P.C. A084 - 91673 - B000				MIDWAY MFG. CO. FRANKLIN PK. ILL.	

DESIGNATION LIST

<u>DESIGNATION NO.</u>	<u>DESCRIPTION</u>
C1, C2	0.1 MF 50V AX CER
C3	.01 MF 50V AX CER
C4	.1 MF 50V AX CER
C5	150 PF 50V AX CER
C6, C7	100 PF 50V AX CER
CP1	10 MF 16V AX
CP2-CP4	.01 MF 50V AX CER
R1, R2	1K OHM 1/4W 5%
R3	2K OHM 1/4W 5%
R4	10K OHM 1/4W 5%
R5	4.7K OHM 1/4W 5%
R6	100K OHM 1/4W 5%
R7	10K OHM 1/4W 5%
R8	100K OHM 1/4W 5%
R9	10K OHM 1/4W 5%
D1-D4	1N4148 DIODE
U1	74LS244
U2	ADC0804
U3	4066
J1	.025 SQ AUTO WIRE
J2	.025 SQ AUTO WIRE
JW1	JUMPER WIRE
PCMH1-PCMH4	SPACER #8
PC BOARD	A080-91649-C000

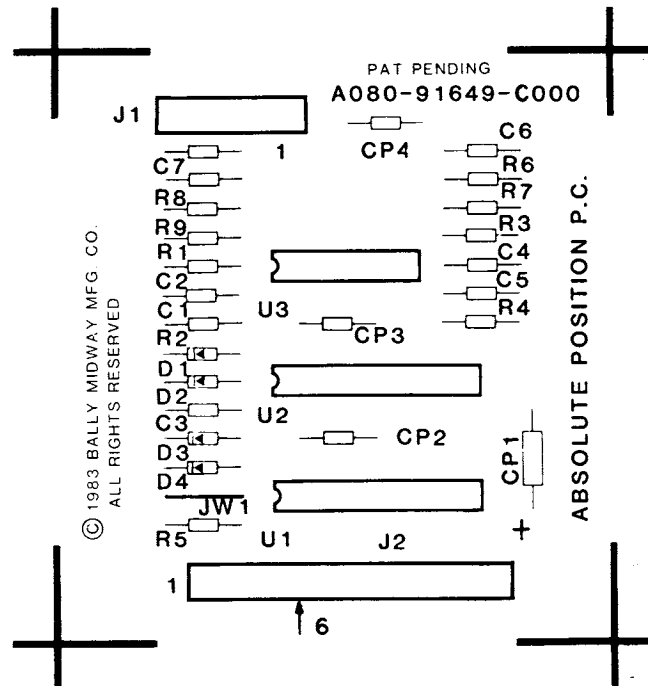

PROJECT ENG: J. BOYDSTON	
DO NOT SCALE DRAWING	
DRAWN BY: [Signature] CHECKED BY: [Signature]	DRN: [Signature]
DATE: 11/11/83	CKD: [Signature]

CROSS REFERENCE LIST

<u>DESCRIPTION</u>	<u>QTY</u>	<u>DESIGNATION NO.</u>	<u>PART NOS.</u>
100 PF 50V AX CER	2	C6, C7	0639-00800-0003
150 PF 50V AX CER	1	C5	0307-00800-0002
.01MF 50V AX CER	4	CP2-CP4, C3	0628-00800-0100
.1 MF 50V AX CER	3	C1, C2, C4	0307-00800-0001
10 MF 16V AX	1	CP1	0628-00800-0300
1K OHM 1/4W 5%	2	R1, R2	
2K OHM 1/4W 5%	1	R3	100E-00005-0061
4.7K OHM 1/4W 5%	1	R5	100E-00005-0068
10K OHM 1/4W 5%	3	R4, R7, R9	100E-00005-0079
100K OHM 1/4W 5%	2	R6, R8	100E-00005-0115
1N4148 DIODE	4	D1-D4	103E-00002-0005
4066	1	U3	0307-00803-0002
74LS244	1	U1	0639-00803-0003
ADC0804	1	U2	0307-00803-0001
.025 SQ AUTO WIRE	21	J1, J2	0017-00033-0479
JUMPER WIRE	1	JW1	0986-00805-0200
SPACER #8	4	PCMH1-PCMH4	0017-00042-0320
P.C. BOARD	1		A080-91649-C000

ABSOLUTE POSITION P.C.

REVISIONS	

	USED ON DISC OF TRON	<i>Bally</i> / MIDWAY MFG. CO. FRANKLIN PK IL
HEAT TREAT	SCALE FULL	NO. REQ'D I PER
MAY L	ASSEMBLY DWG	
FINISH	ABSOLUTE POSITION P.C.	
11/83	A090-91649-C000	
	PART NO. M051 - 00114 - C084	

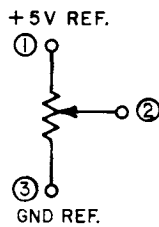
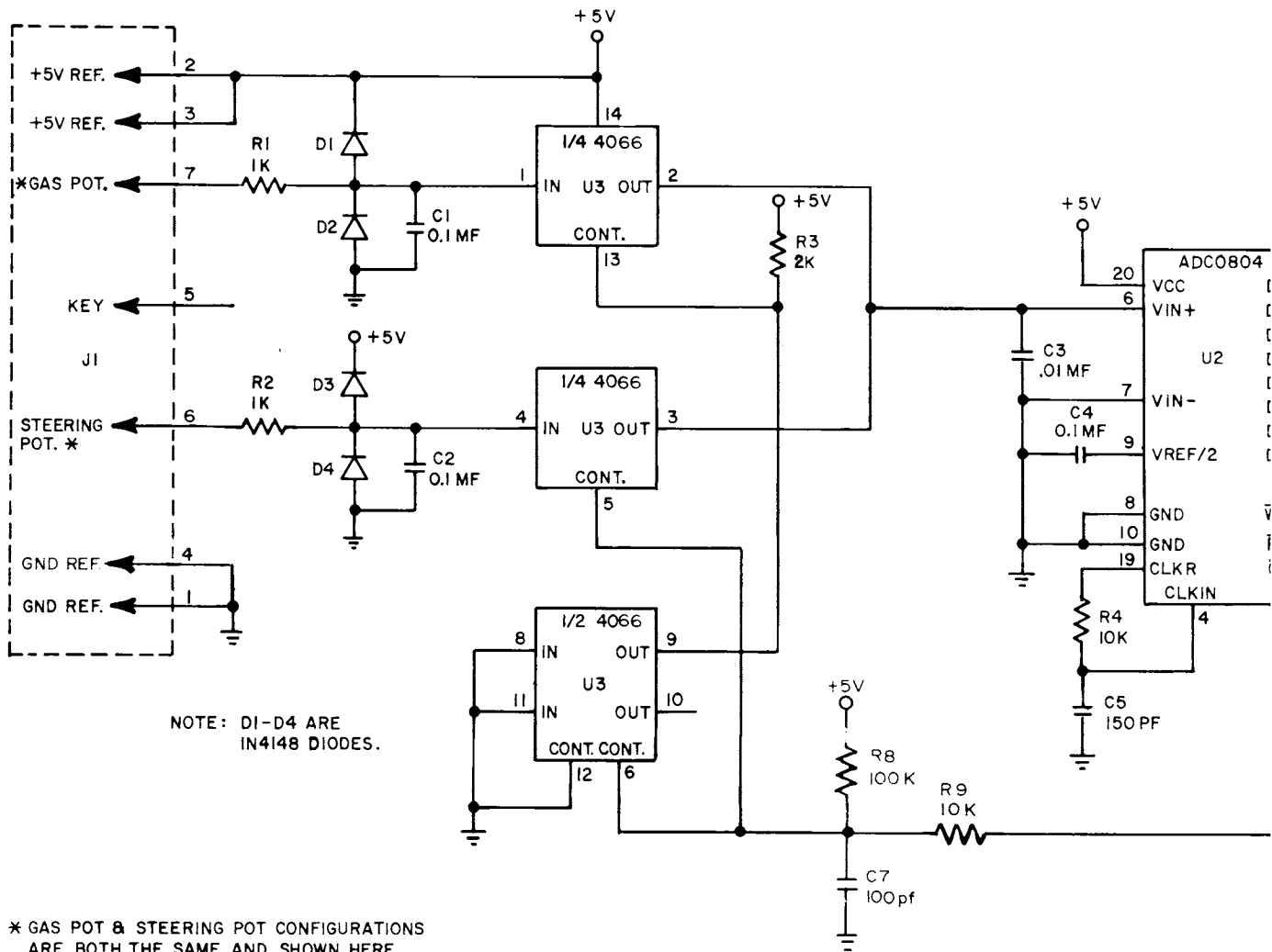

PROJECT ENG: J. BOYDSTON	
DO NOT SCALE DVS	
DIM TOLERANCES UNLESS SPECIFIED	DRW: RLW
IN: 10/27/77	CRD: RLW
REV: 1	DATE: 10/27/77

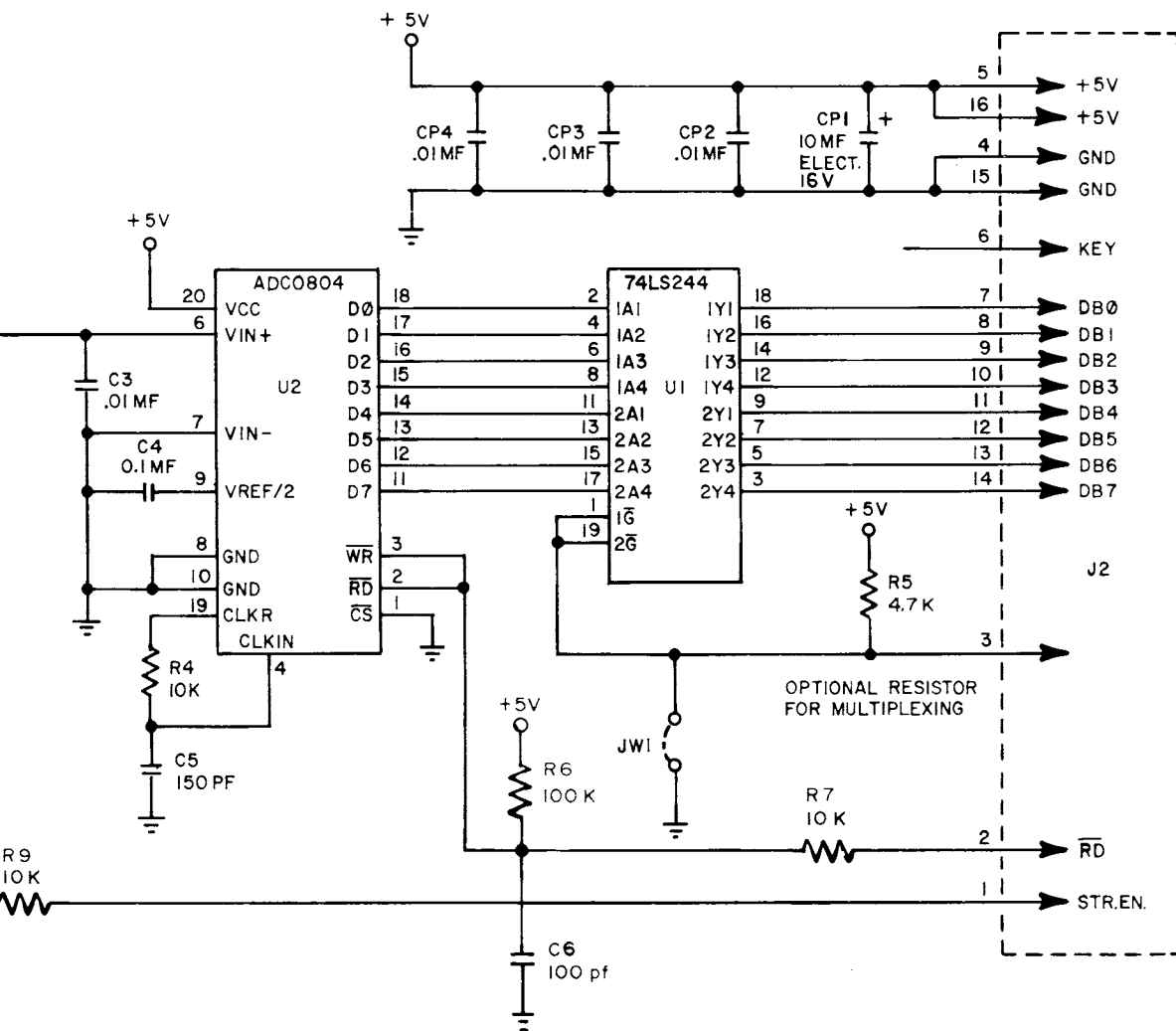

REVISIONS	

PROJECT ENG: J. BOYDSTON		USED ON		Bally / MIDWAY MFG. CO. FRANKLIN PK ILL
DO NOT SCALE DWG		HEAT TREAT	SCALE FULL	
DIM TOLERANCES UNLESS SPECIFIED		DRW. <i>RW</i>	MAT'L.	PART NO
DATE 10/27/83		CRD. <i>...</i>	FINISH	M051 - 00114 - C085
SCHEMATIC DWG. ABSOLUTE POSITION P.C. A084-91649-C000				