

**centuri** T.M.  
**,INC.**  
HIALEAH . FLORIDA . U . S . A

# ROUTE 16®

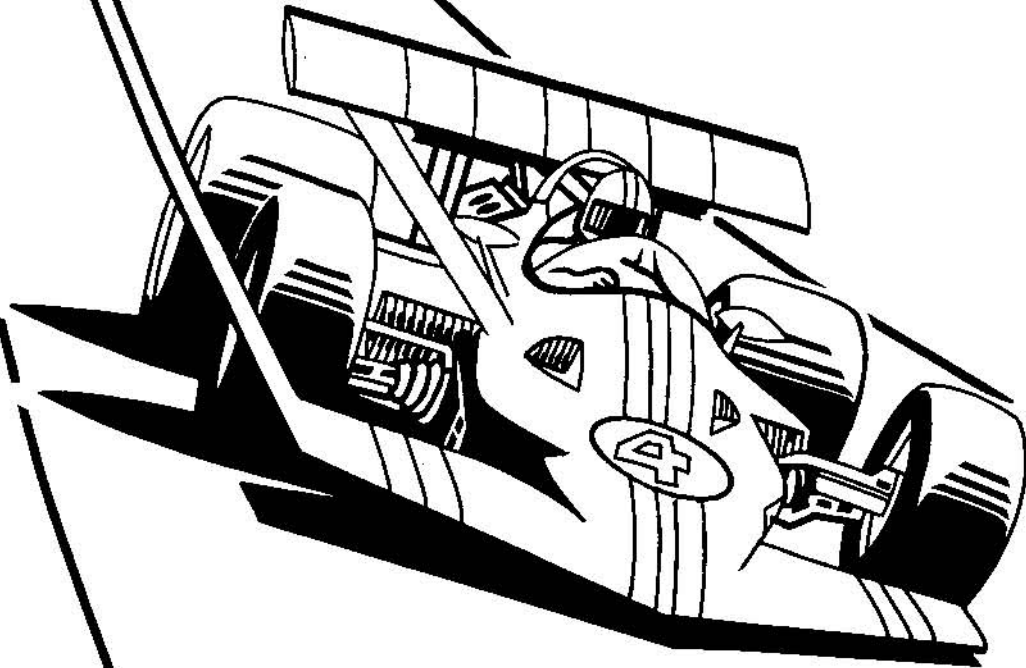

**SERVICE      MANUAL**

# ROUTE 16

CENTURI, INC.

245 W. 74TH PLACE

HIALEAH, FL. 33014

TEL. #(305) 558-5200

CUSTOMER SERVICE:

TEL. #(305) 558-5200 (IN FLORIDA)

TEL. #(800) 327-7710 (OUTSIDE FLORIDA)

TABLE OF CONTENTS

	<u>PAGE NO.</u>
<u>I. INTRODUCTION:</u>	
USER INFORMATION - F.C.C. ....	1
GAME DESCRIPTION (DIAGRAM) .....	2
GAME SUMMARY .....	3
<u>II. SPECIFICATIONS:</u>	
INSTALLATION .....	4
ELECTRICAL REQUIREMENTS .....	4
110/220 CONVERSION INSTRUCTIONS .....	5
<u>III. OPERATION:</u>	
GAME INSTRUCTIONS .....	6
GAME SCORING .....	6
OPERATOR OPTIONAL SWITCH SETTINGS .....	7
OPTIONAL SWITCH SETTINGS .....	7
ROUTINE MAINTENANCE & SERVICE .....	8
POWER SUPPLY .....	8
<u>IV. GENERAL:</u>	
ROM A6 PRINTED CIRCUIT BOARD PARTS LIST .....	9
C.P.U. PRINTED CIRCUIT BOARD PARTS LIST .....	10, 11
POWER SUPPLY PARTS LIST .....	12, 13
CONTROL DECK ASSEMBLY - EXPLODED VIEW .....	14
COIN DOOR ASSEMBLY - FIGURE 1 .....	15
COIN DOOR ASSEMBLY - FIGURE 2 .....	16
<u>V. DRAWINGS:</u>	
110/220 POWER INTERCONNECT DIAGRAM .....	(361-10-0900) ..17
C.P.U. HARNESS DIAGRAM .....	(366-12-0100) ..18
POWER SUPPLY SCHEMATIC .....	(363-17-0300) ..19
COIN DOOR WIRING DIAGRAM .....	(364-62-1000) ..20
CPU/LOGIC BOARD SCHEMATICS:	
SOUND BOARD (1 of 8) .....	(366-10-0400) ..21
S1 BOARD (2 of 8) .....	(366-10-0400) ..22
VRAM2 BOARD (3 of 8) .....	(366-10-0400) ..23
CPU-2 BOARD (4 of 8) .....	(366-10-0400) ..24
VRAM-1 BOARD (5 of 8) .....	(366-10-0400) ..25
CPU-1 BOARD (6 of 8) .....	(366-10-0400) ..26
DUAL PORT RAM (7 of 8) .....	(366-10-0400) ..27
IN/OUT BOARD (8 of 8) .....	(366-10-0400) ..28

USER INFORMATION - F.C.C.

WARNING:

This equipment generates, uses and can radiate radio frequency energy and if not installed and used in accordance with the instructions manual, may cause interference to radio communications. As temporarily permitted by regulation, it has not been tested for compliance pursuant to Subpart J of Part 15 of F.C.C. Rules, which are designed to provide reasonable protection against such interference. Operation of this equipment in a residential area is likely to cause interference in which case the user at his own expense will be required to take whatever measures may be required to correct the interference.

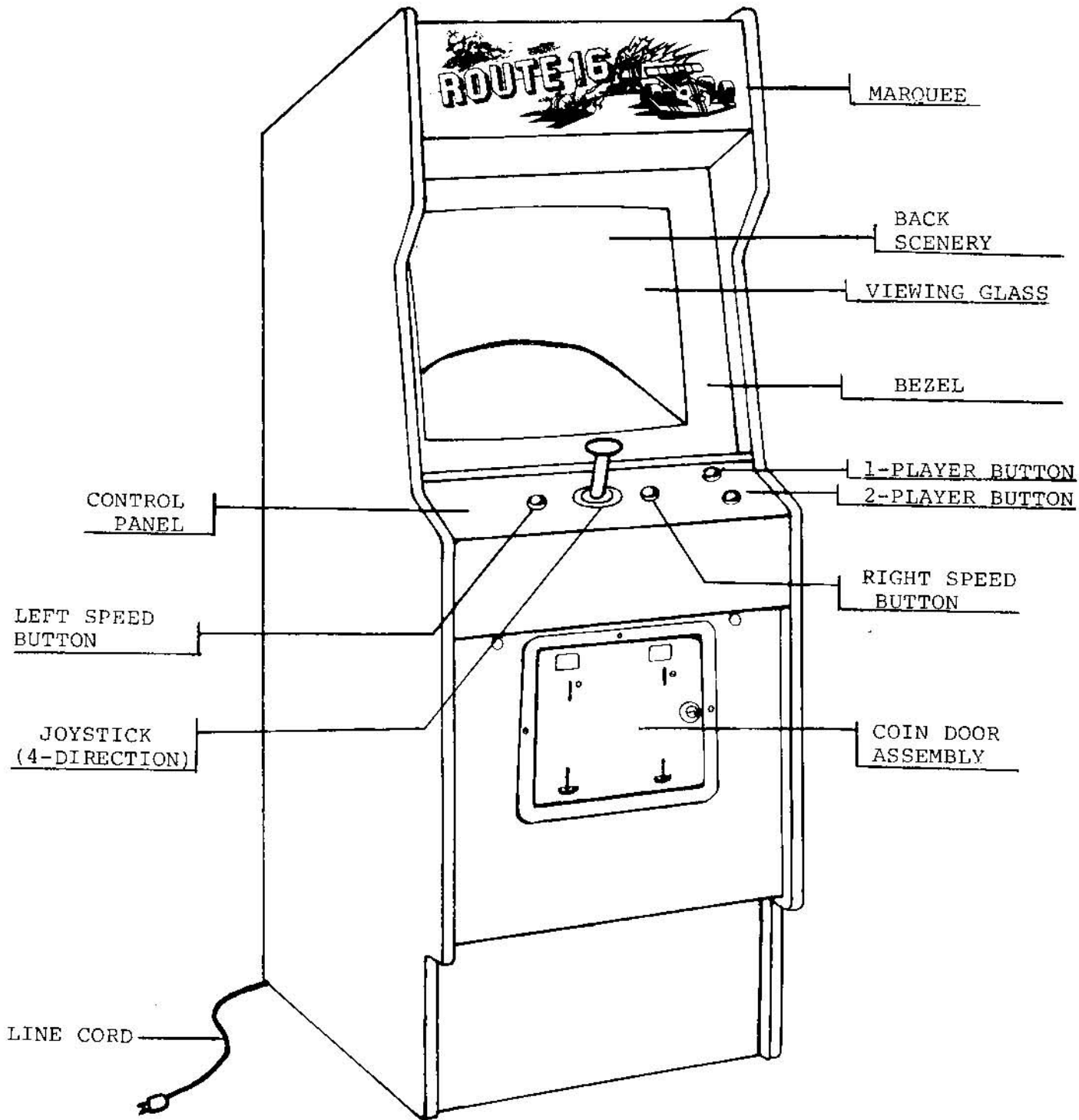

19" "ROUTE 16" VIDEO UPRIGHT

## ROUTE 16

### GAME SUMMARY

Route 16 is a challenging race car game, integrating special features to excite the beginner as well as the seasoned player. The vivid video screen is fascinating, and is complimented by exceptional audio during game play.

The red car is controlled by the joystick feature, and is pursued through 16 different routes (mazes) by three chase cars. The search mode reveals an overview of all 16 routes, and the search mode appears whenever the car exits a route. In the search mode, the player car becomes a red cube, and the chase cars become yellow cubes.

Whenever the player car exits one route, there is a one second delay for a total overview of the game.

Each route has dead-ends, zig-zags, and multiple entrances and exits.

Some routes have the dollar symbol (\$), and the player scores 200 points each time this symbol is cleared. The dollar symbols randomly change to oil slicks, and when encountered, the oil slicks slow down the player car.

The question mark symbol (?), is surrounded by check points (□), and will either reveal a bomb symbol or a bell mark after the player car clears the check point. The bell will add 800 points to the player's score when cleared. Player skill is tested here to avoid the bomb if it appears.

Some routes have a flag symbol, and when the player car clears the symbol, the pursuing cars become dollar symbols, and every effort should be made by the player to chase them down, and add extra points to his score.

One route has a flickering bonus car symbol. When the symbol appears, clear it and earn an additional player car.

One route has an additional game feature. When the player car enters the maze, it is pursued by an attacking monster. The player car cannot clear or collide with the monster, but must avoid it, or be destroyed.

The high-speed button is another feature of Route 16. When pushed, the player car is accelerated to escape the chase cars. Usage of the high-speed button reduces the player car's fuel. At the end of each round, bonus points are added to the player's score for remaining fuel.

After all the symbols are cleared, the round ends. In successive rounds, additional dollar symbols (\$), and additional enemy chase cars are added.

The game is over when all the player cars have crashed.

## INSTALLATION

Your game was shipped from the factory in ready-to-play condition. A brief inspection is suggested before the machine is removed from the carton. If there is damage to the shipping carton, contact the freight carrier for claim purposes. External damage could indicate possible damage to the cabinet and/or electronic components.

After the carton has been satisfactorily inspected, remove the machine from the shipping carton.

Examine the interior of the game for disconnected wires, cables or harnesses and make sure electronic devices are securely mounted in their sockets, etc. Record the game serial number, since it will be required for reference and servicing.

## ELECTRICAL REQUIREMENTS

Unless otherwise specified, this game is set to operate at 110 Volts A.C. See Figure (1) for 110/220 VAC conversion instructions.

Power Supply Chassis schematic information and parts list are included in this manual.

FIGURE (1)

110/220 VAC CONVERSION INSTRUCTIONS

1. This video arcade game has a harnessing configuration that allows the machine to be operated from either a 110 VAC or 220 VAC @ 50 or 60 Hz power source, with only minor changes. The only items requiring a change are the fuses and the jumper plug on the game power transformer.
  2. First, unplug the machine from the wall outlet to completely eliminate shock hazards.
  3. Next, remove the two fuses in the A.C. distribution bracket.
  4. Then, remove the jumper plug on the game power transformer located on the floor of the machine.
  5. Now, depending on what voltage you wish to run the game from, do the following:
    - 110 VAC: Replace the two fuses that go in the bracket with 3-AMP SLOW-BLOW types. Next, plug in the ORANGE jumper plug labeled 110 VAC. The machine can now be operated with an input voltage of 110 Volts AC.
    - 220 VAC: Replace the two fuses that go in the bracket with 1½ AMP SLOW-BLOW types. Next, plug in the RED jumper plug labeled 220 VAC. The machine can now be operated with an input voltage of 220 volts AC.
- NOTE: All games shipped from CENTURI, INC. are in the 110 VAC configuration.





















ROUTE 16 - GAME INSTRUCTIONS

1. INSERT COIN.
2. SELECT ONE-PLAYER OR TWO-PLAYER BUTTON.
3. JOYSTICK CONTROL MANUEVERS PLAYER CAR IN FOUR DIRECTIONS, ENABLING CAR TO TRAVEL THROUGH EACH "ROUTE" (MAZE), AND ENTER AND EXIT EACH "ROUTE".
4. HIGH SPEED BUTTON ACCELERATES PLAYER CAR, BUT DECREASES FUEL.
5. POINTS ARE SCORED BY CLEARING SYMBOLS ON EACH ROUTE.
6. BONUS POINTS ARE SCORED WHEN ALL SYMBOLS ARE CLEARED BEFORE FUEL IS DEPLETED. BONUS POINTS ARE ADDED AS TEN (10) TIMES FUEL BALANCE.
7. BONUS CAR IS ADDED WHEN PLAYER CAR CLEARS FLASHING CAR SYMBOL.
8. CLEARING FLAG MARK CHANGES ENEMY CARS TO DOLLARS (\$) POINTS.
9. MYSTERY MARK (? MARK) IS REVEALED AS A DOLLAR SYMBOL OR BOMB SYMBOL WHEN PLAYER CAR CROSSES CHECK POINTS SURROUNDING MYSTERY MARK.
10. GAME IS OVER WHEN ALL PLAYER CARS HAVE CRASHED.

GAME SCORING

POINT VALUES

	DOLLAR	FLAG	QUESTION MARK	BELL (\$)	BOMB	EXTRA CAR	OIL	ENEMY CAR	PLAYER CAR
ONE ROUTE VIEW:									
	200 points	500 points	? points	800 points	0	-	0	-	-
ALL ROUTES VIEW:									

## OPERATOR OPTIONAL SWITCH SETTINGS

The option switches are located on the CPU Board. The option switches and audio control can be reached through the back of the machine.

The following table will assist your adjustments:

### OPTIONAL SWITCH SETTINGS

Switch 1 controls the number of cars allotted each player per game. The switch settings should be as follows:

<u>SWITCH 1:</u>	<u>NUMBER OF CARS:</u>
OFF	3
ON	5

Switches 2 and 3 are not used.

Switches 4 and 5 control the game fees. These settings can be set for one coin (25¢) or two coins (50¢) per play as follows:

<u>SWITCH 4:</u>	<u>SWITCH 5:</u>	<u>COIN SETTING:</u>
OFF	OFF	One Coin (25¢) - One Play
ON	OFF	Two Coins(50¢) - One Play

Switch 6 is a preset factory adjustment, and should remain in the "ON" position for the video upright game.

Switch 7 is preset at the factory, and should be set in the "ON" position for the monitor picture adjustment.

Switch 8 allows the operator to regulate the availability of music in the attract mode. The following settings regulate this function:

<u>SWITCH 8:</u>	<u>ATTRACT MODE MUSIC:</u>
ON	Music Available
OFF	Music Not Available

## ROUTINE MAINTENANCE & SERVICE

Because of the solid state electronic circuitry, this machine should require very little maintenance and only occasional adjustments. However, it is necessary to take measures to insure this.

The volume control is located on the bottom side of the printed circuit board farthest from the side of the cabinet, and can be accessed through the rear door.

The video monitor has been properly adjusted before shipping. Occasionally minor adjustments are necessary, see monitor specifications and schematics for technical information. Adjustment controls for the monitor are located at the rear of the monitor.

This machine should be serviced only by a qualified technician.

Do not make any adjustments on this machine while the power is on.

For service information, contact:

CENTURI, INC.

Customer Service Department

#800-327-7710 (Outside the state of Florida)

#305-556-5888 (In Florida)

## POWER SUPPLY

The Computer Board in this game operates most efficiently and reliably when the power supply is set so that the voltage on the board is 5.0 Volts,  $\pm 0.1$  Volts. To check this, place a meter across 5 Volts and ground at the edge connector. If necessary, adjust the screwdriver control on the power supply so that the meter reads between 4.9 and 5.1 Volts.

PARTS LIST

<u>NO.</u>	<u>PART NUMBER:</u>	<u>DESCRIPTION:</u>	<u>USAGE:</u>
1	50010306	MB8841	1
2	50010264LS	74LS368	3
3	50010105LS	74LS32	1
4	50010139LS	74LS175	1
5	50040002	.1 mfd, 50 Volt Ceramic Disc Cap.	3
6	50040141	.001mfd, 50 V., Ceramic Disc Cap.	1
7	50040170	220PF, 50 V., Ceramic Disc Cap.	1
8	50060178	4.7mfd, 10 V. Tantalum Capacitor	1
9	50100014	1N914 Diode	1
10	50030063	10K, 1/4 W., 5% Resistor	1
11	50030147	6.8K Ohm, 1/4 W., 5% Resistor	1
12	50030006	4.7K Ohm, 1/4 W., 5% Resistor	1
13	50210222	Printed Circuit Board	1
14	50150297	Square Pin Straight Wafer, (Molex #22-03-2121)	2

PARTS LIST

<u>NO.</u>	<u>PART NUMBER:</u>	<u>DESCRIPTION:</u>	<u>USAGE:</u>
1	50010233	TMS 4116 I.C.	16
2	50010028LS	74LS153 I.C.	8
3	50010019LS	74LS74 I.C.	5
4	50010045LS	74LS157 I.C.	9
5	50010096LS	74LS08 I.C.	2
6	50010002LS	74LS00 I.C.	7
7	50010025LS	74LS95 I.C.	4
8	50010007LS	74LS10 I.C.	4
9	50010005LS	74LS04 I.C.	7
10	50010008LS	74LS20 I.C.	1
11	50010022LS	74LS86 I.C.	4
12	50010264LS	74LS368 I.C.	10
13	50010012LS	74LS30 I.C.	1
14	50010204LS	74LS393 I.C.	2
15	50010139LS	74LS175 I.C.	1
16	50010014LS	74LS42 I.C.	3
17	50010105LS	74LS32 I.C.	6
18	50010242	2114 (MPD 2114 - LC-3)	2
19	50010195LS	74LS367	10
20	50010305	MB7052	2
21	50010030LS	74LS174	3
22	50010004LS	74LS02	1
23	50010171	2716	10
24	50010187	Z-80 C.P.U.	2
25	50010307	7946 (Sound Chip AY-3-8910)	1
26	50130034	8-Position DIP Switch	1
27	50040002	.1mfd, 50 Volt, Ceramic Disc Cap.	20
28	50040066	470PF, 50 V., Ceramic Disc Cap	3
29	50040005	0.01mfd, 50 V., Ceramic Disc Cap.	1
30	50040168	30PF, 50 V., Ceramic Disc Cap.	1
31	50040141	0.001mfd, 50 V. Ceramic Disc Cap.	1
32	50030095	330 Ohm, 1/4 W., 5% Resistor	2
33	50030063	10K Ohm, 1/4 W., 5% Resistor	3
34	50030150	47K Ohm, 1/4 W., 5% Resistor	1
35	50040125	220 Ohm 1/4 W., 5% Resistor	2
36	50030310	560 Ohm, 1/4 W., 5% Resistor	1
37	50030091	56K Ohm, 1/4W., 5% Resistor	1
38	50030185	1.8K Ohm, 1/4 W., 5% Resistor	1
39	50030051	1K Ohm, 1/4 W., 5% Resistor	2
40	50030007	100K Ohm, 1/4 W., 5% Resistor	1
41	50360010	2.2K Ohm, 1/4 W., 9-Pin SIP Resistor	3
42	50070016	10MH <sub>z</sub> Crystal	1
43	50020065	TIP 120 NPN Darlington Transistor	1
44	50060176	0.47mfd, 16 V., Tantalum Cap.	1
45	50060177	100mfd, 16V., Radial Lytic Cap.	3
46	50060156	10mfd, 16V., Radial Lytic Cap.	1
47	50060139	47mfd, 16V., Radial Lytic Cap.	1

C.P.U. PRINTED CIRCUIT BOARD

#50330011

PARTS LIST

Page -2-

<u>NO.</u>	<u>PART NUMBER:</u>	<u>DESCRIPTION:</u>	<u>USAGE:</u>
48	50040169	.1mfd, 50 V. Mylar Capacitor	1
49	50150111	16-Pin I.C. Socket	4
50	50150061	24-Pin I.C. Socket	11
51	50150112	18-Pin I.C. Socket	2
52	50150060	40-Pin I.C. Socket	2
53	50010271	MB3713 Audio Amplifier	1
54	50100014	1N914	1
55	50080034	100K Potentiometer, CTS 375 V.	1
56	50210223	P.C.B. Route 16, C.P.U.-Logic	1
57	50175506	Jumper, 22GA, insulated Wire	36"

PARTS LIST

<u>SYMBOL:</u>	<u>DESCRIPTION:</u>	<u>USAGE:</u>
T1	Transformer, Single Phase, 24 VA	1
L1	Coil, 1.6 mH, 1.5A	1
L2, L4	Coil, SF-T8-50S-03	2
L3	Coil, SF-HP-2A-03	1
D1	Diode, V19G	1
D2	Diode, V06C	1
D3, D6	Diode, 1S1588	2
D4	Diode, S15S3	1
D5, D7	Diode, 5CH1M	2
D12, D13	Diode, F113B	2
D14	Diode, F113B	1
RF1	Diode, S4VB40 (Bridge Type)	1
Q1	Transistor, 2SC2504	1
Q2	Transistor, 2SD467 (B)	1
Q3	Transistor, 2SC460 (B)	1
Q4	Transistor, 2SA673 (B)	1
IC1	Integrated Circuit, RM723DC or HA17723G-02	1
PC1	Photo Coupler, PS2001	1
R1	Resistor, 2 Watt, 18 Ohm	1
R8, R9	Resistor, 2 Watt, 47K Ohm	2
R3, 1-4	Resistor, 2 Watt, 15 Ohm	4
R4	Resistor, 1 Watt, 56 Ohm	1
R12	Resistor, 1 Watt, 100 Ohm	1
R28	Resistor, 1 Watt, 470 Ohm	1
R7	Resistor, 1 Watt, 0.56 Ohm	1
R26	Resistor, 1 Watt, 0.82 Ohm	1
R23	Resistor, 1/4 Watt, 22 Ohm	1
R10	Resistor, 1/4 Watt, 33 Ohm	1
R27	Resistor, 1/4 Watt, 68 Ohm	1
R2	Resistor, 1/4 Watt, 330 - 470 Ohm	1
R22	Resistor, 1/4 Watt, 220 Ohm	1
R21	Resistor, 1/4 Watt, 270 Ohm	1
R6	Resistor, 1/4 Watt, 330 Ohm	1
R11	Resistor, 1/4 Watt, 68 Ohm	1
R20	Resistor, 1/4 Watt, 470 Ohm	1
R17	Resistor, 1/4 Watt, 680 Ohm	1
R19	Resistor, 1/4 Watt, 800 Ohm	1
R18	Resistor, 1/4 Watt, 1.2K Ohm	1
R5	Resistor, 1/4 Watt, 10K Ohm	1
R16	Resistor, 1/4 Watt, 220K Ohm	1
R29	Resistor, 3 Watt, 27 Ohm	1
R39	Resistor, 1/4 Watt, 4.7K Ohm	1
R38	Resistor, 1/4 Watt, 5.6K Ohm	1
R24	Resistor, 1/4 Watt, 330 Ohm	1
R25	Resistor, 1/4 Watt, 150 Ohm	1
RV1	Variable Resistor, RJ-6P501	1

POWER SUPPLY

#50350001

PARTS LIST

Page -2-

<u>SYMBOL:</u>	<u>DESCRIPTION:</u>	<u>USAGE:</u>
C1, C2	Capacitor, ECK-DAL102E	2
C3-1,-2	Capacitor, 160VSN100	2
C9, C10	Capacitor, SM10VB-2200	2
C11, C23	Capacitor, SM10VB-2200	2
C12,C13,C15	Capacitor, SL25VB-10	3
C27	Capacitor, SL25VB-10	1
C18,C19,C20	Capacitor, SM35VB-1000	3
C26	Capacitor, SM35VB-1000	1
C21,C22,C25	Capacitor, SM16VB-1000	3
C5	Capacitor, DMY21H472K	1
C6	Capacitor, DMY21H104K	1
C14,C16	Capacitor, DMY21H222K	2
C4	Capacitor, CM20XC511K5	1
C8	Capacitor, MDD22G473K	1
C5-2	Capacitor, DMY21H222K	1
1, F2	Enclosed Type Fuse, 3A	2



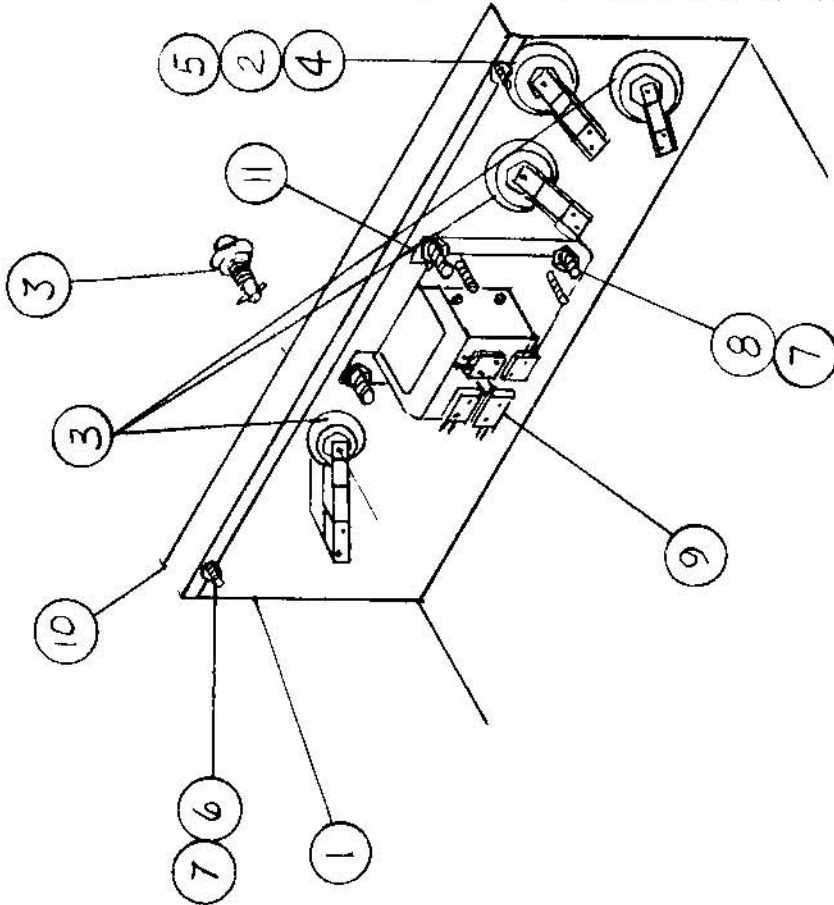

ITEM	QTY	PART NO	DESCRIPTION
11	2	366-03-0500	JOYSTICK MOUNTING BRKT
10	1	361-03-0600	DECK & GLASS ANGLE BRKT
9	1	50130058	JOYSTICK (4 POSITION) TAIL
8	4	10111006	#10-24 x 1/2 CARR. BOLT, BLK D.
7	6	10150007	KEPS NUT #10-24
6	2	10111004	#10-24 x 1/2 CARR. BOLT, BLK D.
5	4	50130050	PAL NUT
4	1	50130049	RED BUTTON ASSY
3	3	50130048	WHITE BUTTON ASSY
2	4	50130047	SWITCH & BRKT
1	1	366-01-0500	CONTROL PANEL & OVERLAY ASSY
			DESCRIPTION
BILL OF MATERIAL			

OC. APV'D		PROD. APV'D	QTY.	ASSEMBLY NO.
<b>centun</b> <sup>inc</sup> HIALEAH, FLORIDA 33014				
NAME		CONTROL DECK ASSY		
MATERIALS		HEAT TREAT. FINISH		
DWN. APP'D.	DATE	SCALE	PART NO.	REV.
AAN	4-6-81	3X	366-01-0800	

TOLERANCES	
Unless Otherwise Specified	
FRACTIONS	± 1/32
DECIMALS 2 PL	± .015
DECIMALS 3 PL	± .005
HOLES	+ .003
ANGLES	- .001
SHT. MET BENDS	± 1/2°

AF 17899A

# 2800 SERIES COIN DOOR EXPLODED VIEW

25¢ U.S. COIN

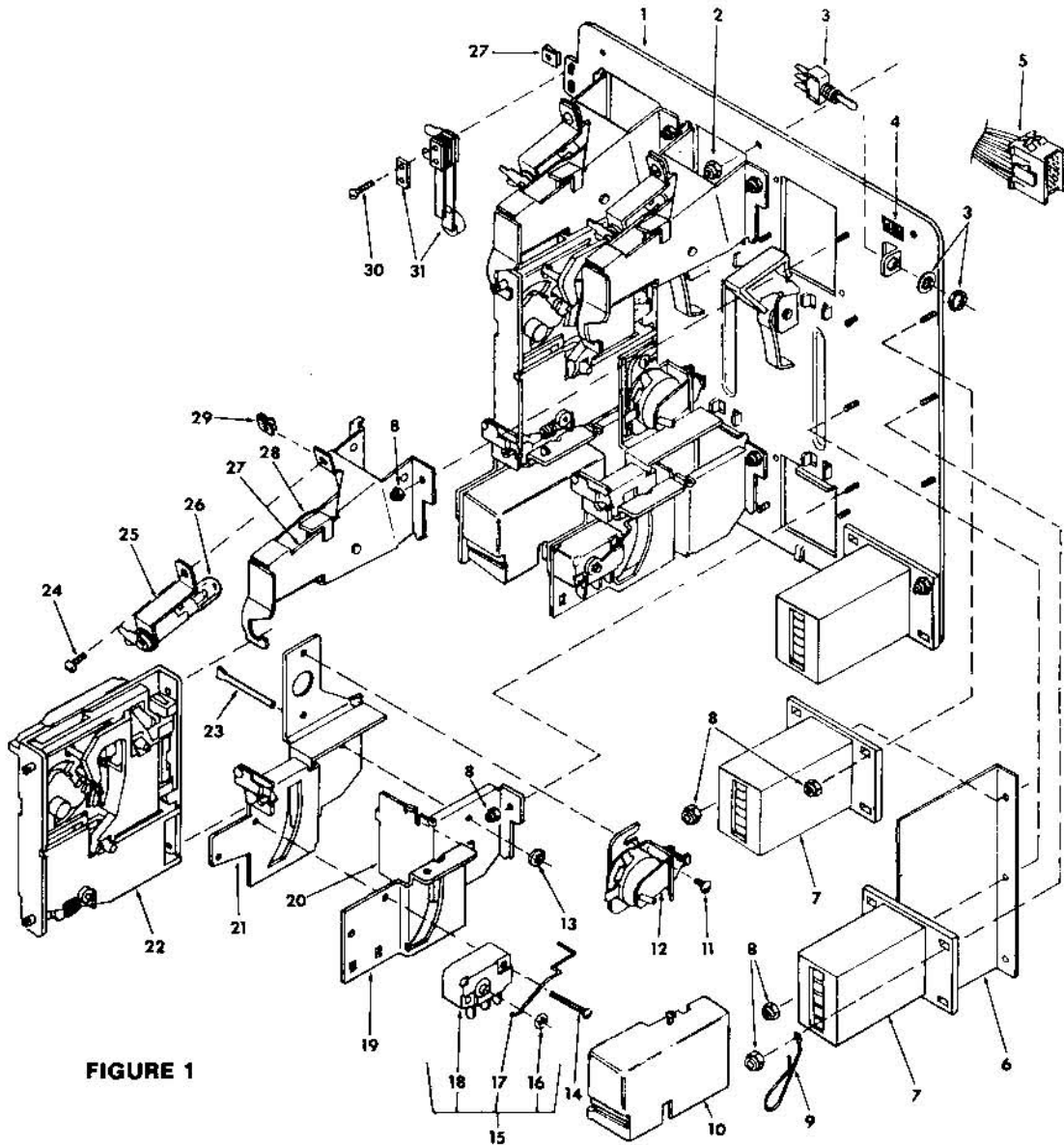
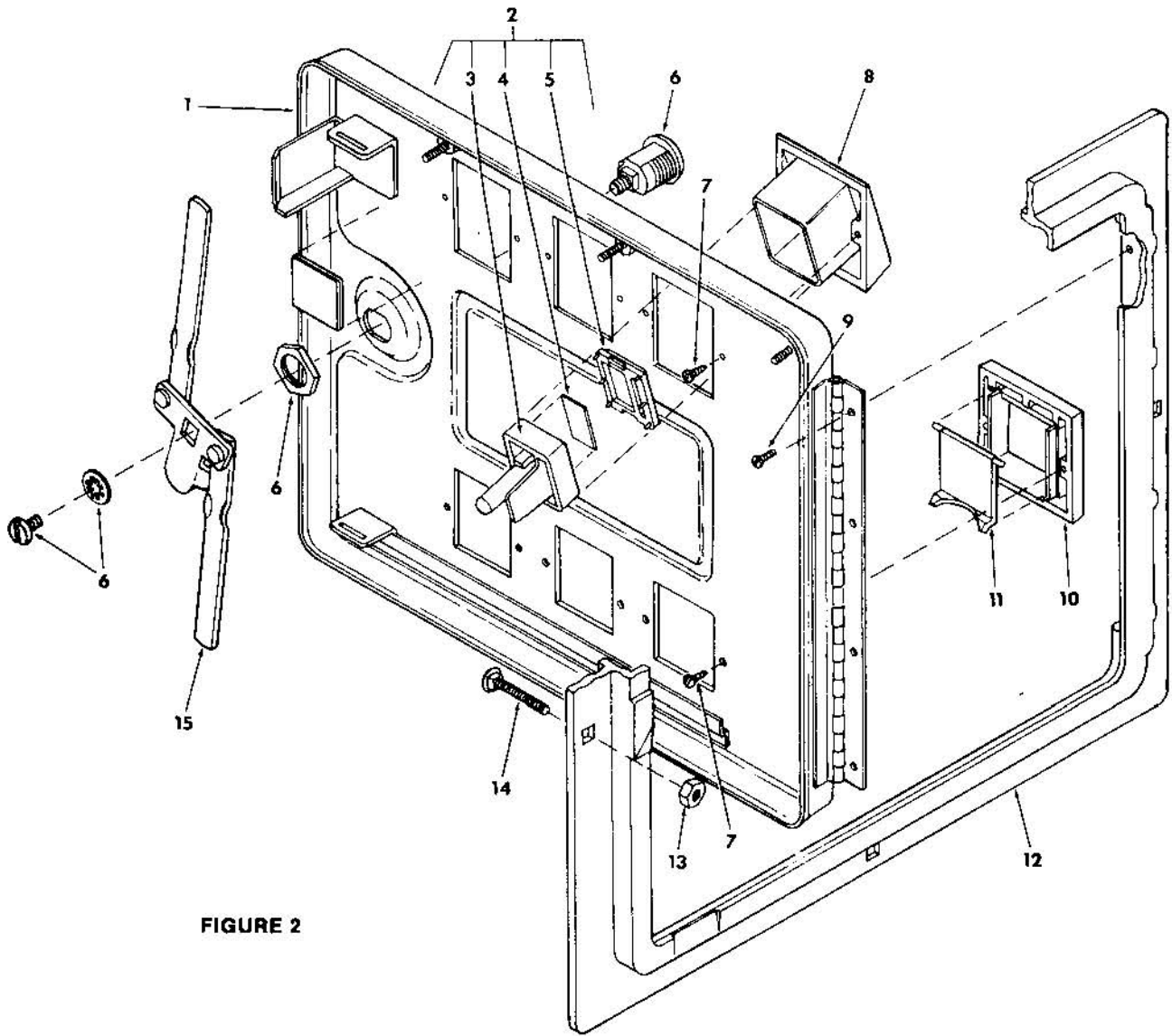

FIGURE 1

Index No.	Part No.	Description	Index No.	Part No.	Description
1	404429	Inner Panel With Levers Sub-Assembly	17	904710-1	Silver Switch Wire — for U.S. 25¢ Coin
2	400-8	Nut	18	904845	Switch
3	904782	Toggle Switch	19	904701	Coin Chute
4	904706	Test Switch Decal	20	904598	Coin Return Box
5		Custom Harness Assembly	21	404428	Switch and C.R.E.M. Coil Bracket Assembly
6	904822	Insulation	22	5301-10	25¢ Acceptor
7	404352	Coin Counter Assembly (6 Volt D.C.)	23	905115	Bar
8	400-4	Nut	24	110-4-6	Screw
9	904722	Wire Key Holder	25	904717	Miniature Bayonet-Base Lamp Socket
10	904762	Switch Cover	26	904716	#47 Lamp (6.3 Volt)
11	100-6-3	Screw	27	404418	Coin Inlet Chute Sub-Assembly
12	404354	C.R.E.M. Coil Assembly, 12 Volts D.C.	28	904594	Right Half of Coin Inlet Chute
13	904936	Keeper	29	904712	"U"-Type Fastener
14	100-4-12	Screw	30	116-4-8	Screw
15	404353	Coin Switch Assembly for U.S. 25¢ Coin	31	904704	Slam Switch Assembly
16	900651	Retainer			

**2800 SERIES COIN DOOR EXPLODED VIEW**  
**25¢ U.S. COIN**



**FIGURE 2**

<b>Index No.</b>	<b>Part No.</b>	<b>Description</b>	<b>Index No.</b>	<b>Part No.</b>	<b>Description</b>
1	404341	Coin Door Only (2 Coin)	7	345-4-5	Screw
	404341-1	Coin Door Only (3 Coin)	8	904588	Coin Button Housing
2	404348-1	Coin Return Button Assembly for U.S. 25¢ Coin	9	325-4-4	Screw
3	904591	Coin Return Button	10	904590	Coin Return Bezel
4	904703	U.S. 25¢ Price Decal	11	904599	Coin Return Cover
5	904589-2	Coin Return Button Cover for U.S. 25¢ Coin	12	904581	Coin Door Frame, 11-5/8" x 13-3/8" Mounts in a 10-3/8" x 12-3/16" Opening
6	904707-1	Lock Assembly	13	406-416	Hex Nut
			14	904734	Carriage Bolt
			15	404357	Locking Arm Assembly

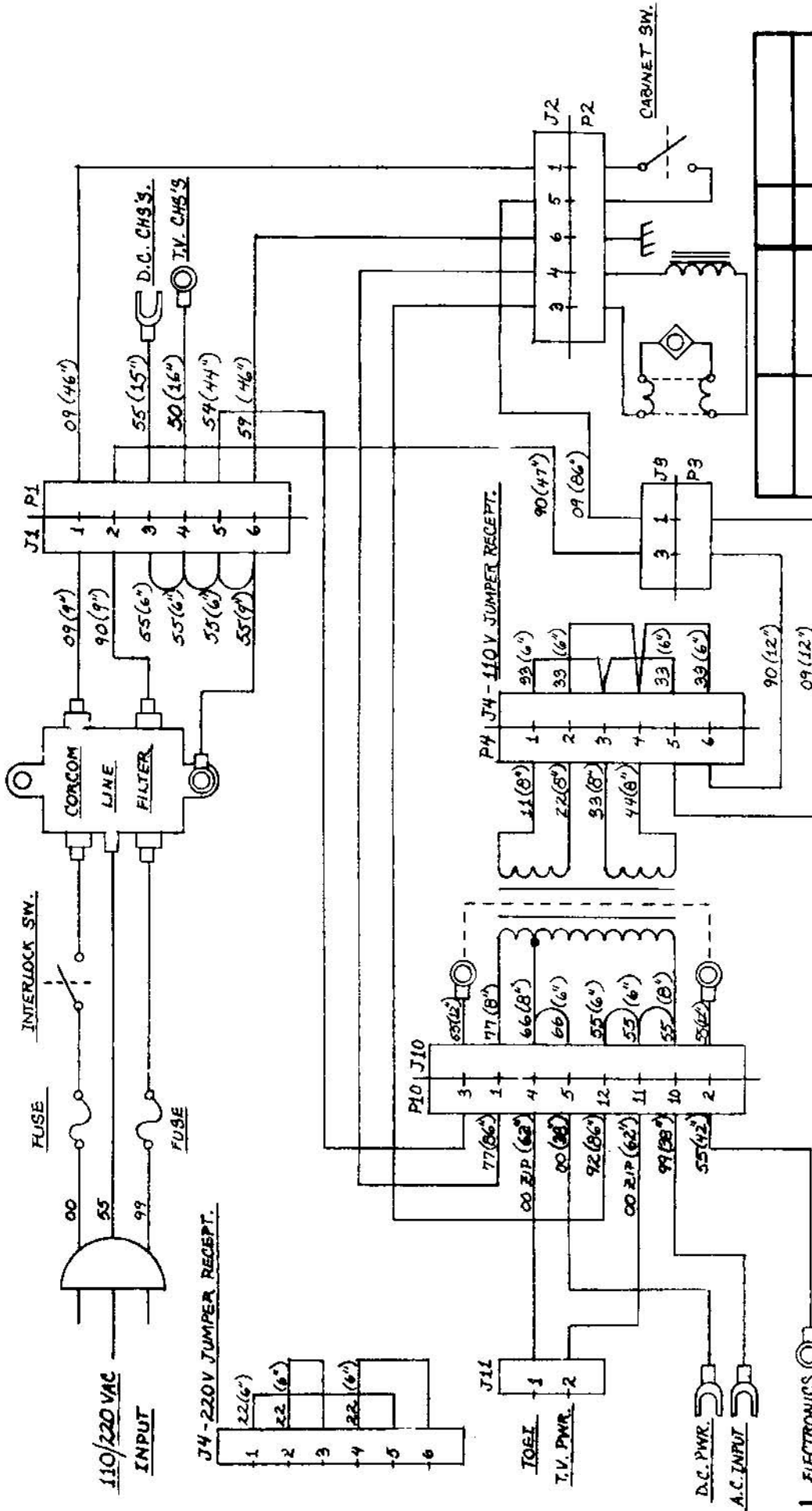

REV. LET.	BY	REVISION	DATE	SCALE	PART NO.	REV.
			1-14-81		361-10-0900	

ELECTRONICS CHASIS		CENTURY, INC.		ASSEMBLY ON	
QC. APVD	PROD. APVD	QTY.	HEAT TREAT.	FINISH	REV.

TOLERANCES		NAME	
Unless Otherwise Specified			
FRACTIONS	± 1/32	Century, Inc.	
DECIMALS 2 PL	± .018	HIALEAH, FLORIDA 33014	
DECIMALS 3 PL	± .006	19" : 110/220V POWER INTERCONNECT DIAG.	
HOLES	± .003		
ANGLES	± 1/2°		
SHT. MET BENDS	± 2°		

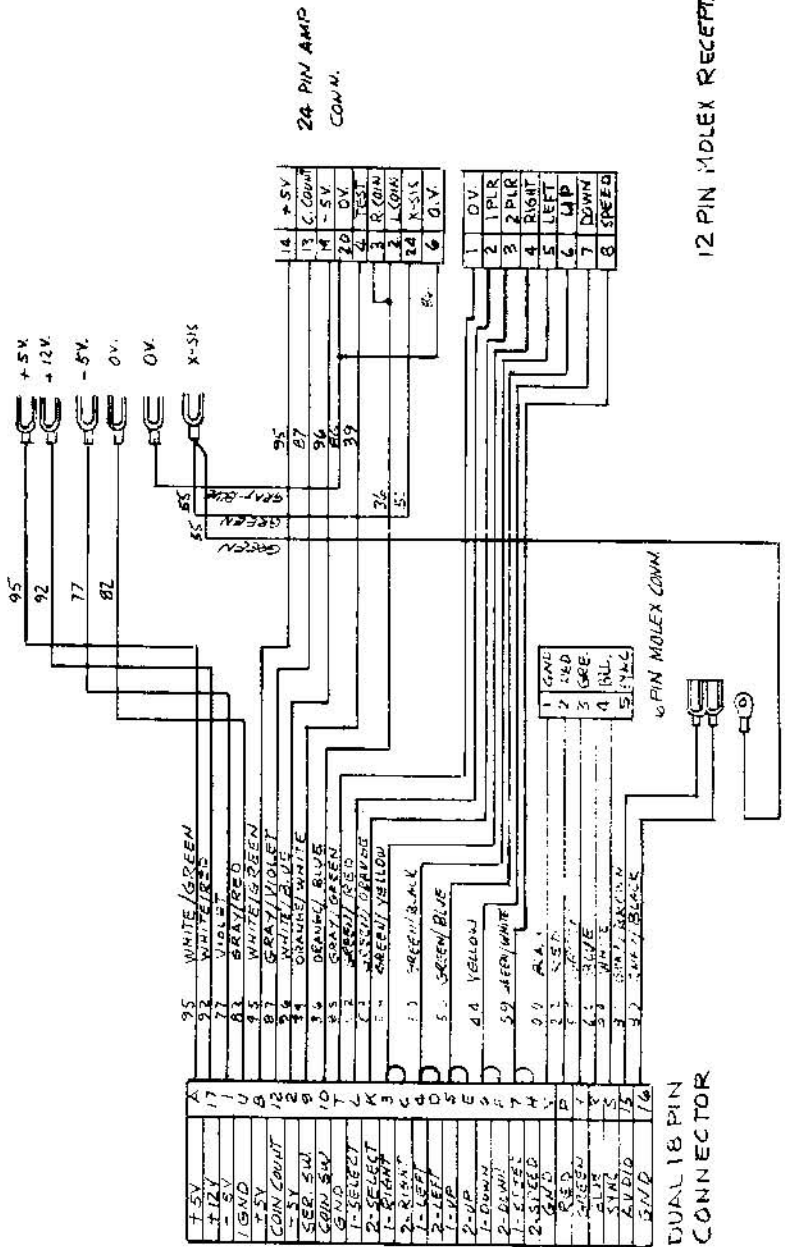

12 PIN MOLEX RECEPTACLE

REV. LET.	ECN NO.	REVISION	BY																				
<table border="1"> <tr> <th colspan="2">TOLERANCES</th> </tr> <tr> <td>Unless Otherwise Specified</td> <td></td> </tr> <tr> <td>FRACTIONS</td> <td>± 1/32</td> </tr> <tr> <td>DECIMALS 2 PL</td> <td>± .016</td> </tr> <tr> <td>DECIMALS 3 PL</td> <td>± .005</td> </tr> <tr> <td>HOLES</td> <td>± .003</td> </tr> <tr> <td>ANGLES</td> <td>± .001</td> </tr> <tr> <td>SHT. MET BENDS</td> <td>± 1/2°</td> </tr> <tr> <td></td> <td>± 2°</td> </tr> </table>				TOLERANCES		Unless Otherwise Specified		FRACTIONS	± 1/32	DECIMALS 2 PL	± .016	DECIMALS 3 PL	± .005	HOLES	± .003	ANGLES	± .001	SHT. MET BENDS	± 1/2°		± 2°		
TOLERANCES																							
Unless Otherwise Specified																							
FRACTIONS	± 1/32																						
DECIMALS 2 PL	± .016																						
DECIMALS 3 PL	± .005																						
HOLES	± .003																						
ANGLES	± .001																						
SHT. MET BENDS	± 1/2°																						
	± 2°																						
<table border="1"> <tr> <td>OC. APVD</td> <td>PROD. APVD</td> <td>QTY.</td> <td>ASSEMBLY NO.</td> </tr> <tr> <td></td> <td></td> <td></td> <td></td> </tr> </table>				OC. APVD	PROD. APVD	QTY.	ASSEMBLY NO.																
OC. APVD	PROD. APVD	QTY.	ASSEMBLY NO.																				
<table border="1"> <tr> <td colspan="2" style="text-align: center;"><b>centur</b></td> <td colspan="2" style="text-align: center;">HIALEAH, FLORIDA 33014</td> </tr> <tr> <td colspan="4" style="text-align: center;">NAME CPU HARNESS - ROUTE 16</td> </tr> <tr> <td colspan="4" style="text-align: center;">MATERIALS HEAT TREAT. FINISH</td> </tr> <tr> <td>APP'D</td> <td>DATE</td> <td>SCALE</td> <td>PART NO.</td> </tr> <tr> <td>AAW</td> <td>3-27-81</td> <td>366-12-0100</td> <td>REV.</td> </tr> </table>				<b>centur</b>		HIALEAH, FLORIDA 33014		NAME CPU HARNESS - ROUTE 16				MATERIALS HEAT TREAT. FINISH				APP'D	DATE	SCALE	PART NO.	AAW	3-27-81	366-12-0100	REV.
<b>centur</b>		HIALEAH, FLORIDA 33014																					
NAME CPU HARNESS - ROUTE 16																							
MATERIALS HEAT TREAT. FINISH																							
APP'D	DATE	SCALE	PART NO.																				
AAW	3-27-81	366-12-0100	REV.																				



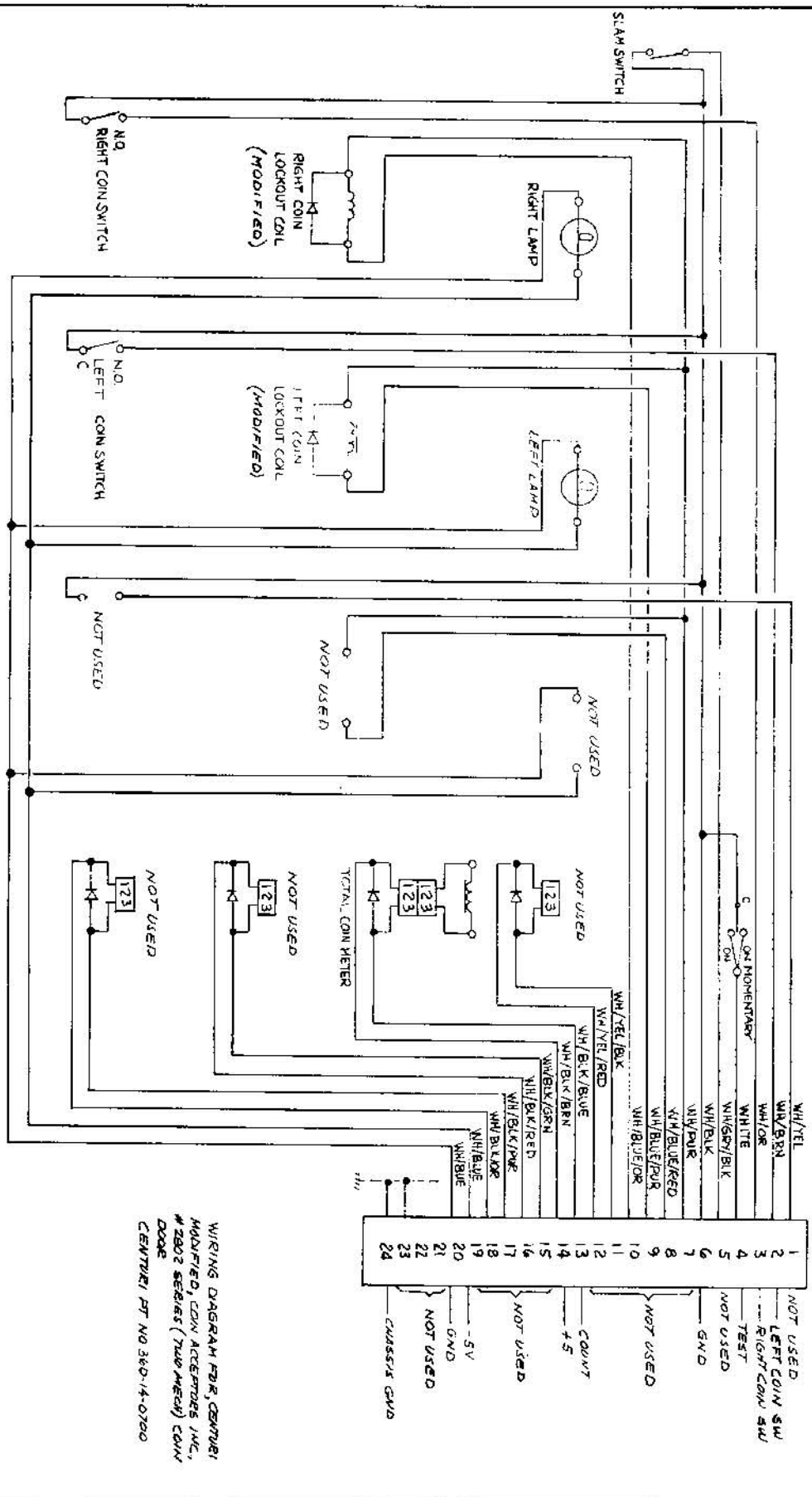

REVOLUTIONS		DISPOSITION OF EXISTING PARTS		G O APP	
REV LETTER	ITEM NO	ECN NO	DESCRIPTION	RE WORK	SCRAP

WIRING DIAGRAM FOR CENTURI  
 MODIFIED, COIN ACCEPTORS INC.,  
 #2802 SERIES (TWO MECH) COIN  
 DOOR  
 CENTURI PT NO 360-14-0700

TOLERANCES		CENTURI INC.	
FRACTIONS	DECIMALS	1780 W. 4th AVENUE	HALEAH, FLORIDA 33010
1/32	.03	COIN DOOR WIRING DIAGRAM	
1/16	.015	DATE	SCALE
1/8	.0075	1-72-0	324-6-21000
1/4	.00375	APP	REV
1/2	.001875		
1	.0009375		
2	.00046875		
3	.000234375		
4	.0001171875		
5	.00005859375		
6	.000029296875		
7	.0000146484375		
8	.00000732421875		
9	.000003662109375		
10	.0000018310546875		
11	.00000091552734375		
12	.000000457763671875		
13	.0000002288818359375		
14	.00000011444091796875		
15	.000000057220458984375		
16	.0000000286102294921875		
17	.00000001430511474609375		
18	.000000007152557373046875		
19	.0000000035762786865234375		
20	.00000000178813934326171875		
21	.000000000894069671630859375		
22	.0000000004470348358154296875		
23	.00000000022351741790771484375		
24	.000000000111758708953857421875		

AY-3-8912 1  
SN76477 1

74CS10 1  
74LS00 1  
MB37/3 1

R 100K 1/2W 1  
1K " 1(2)  
5K " 1  
10K " 3  
47K " 1  
230K " 1  
30K " 1

10K TRIMMER POT  
R1-R9  
(NOT SPECIFIED)  
C 18.47M $\mu$ W TANTALUM CAP. 3  
47M $\mu$ W 1  
100M $\mu$ W 3  
1  
C1-C5 MYLAR CAP  
(NOT SPECIFIED)  
C109B 1  
1000P MYLAR CAPACITOR 1

5/8 R C-5, R1-R9  
C1 1W(10-50E)  
C2 1000P(M)  
C3 27M(10-50E)  
C4 1M(10-50E)  
C5 0.022M(M)  
E: CHEMICAL CONDENSOR  
M: MYLAR CAP.  
R1 47K  
R2 33M  
R3 20K  
R4 47K  
R5 47K  
R6 75K  
R7 100K  
R8 2K  
R9 10K  
NOTE: AY-3-8912 BETWEEN PINS VSS-KC  
0.1MFD CERAMIC CAP 5/16" STALLED.

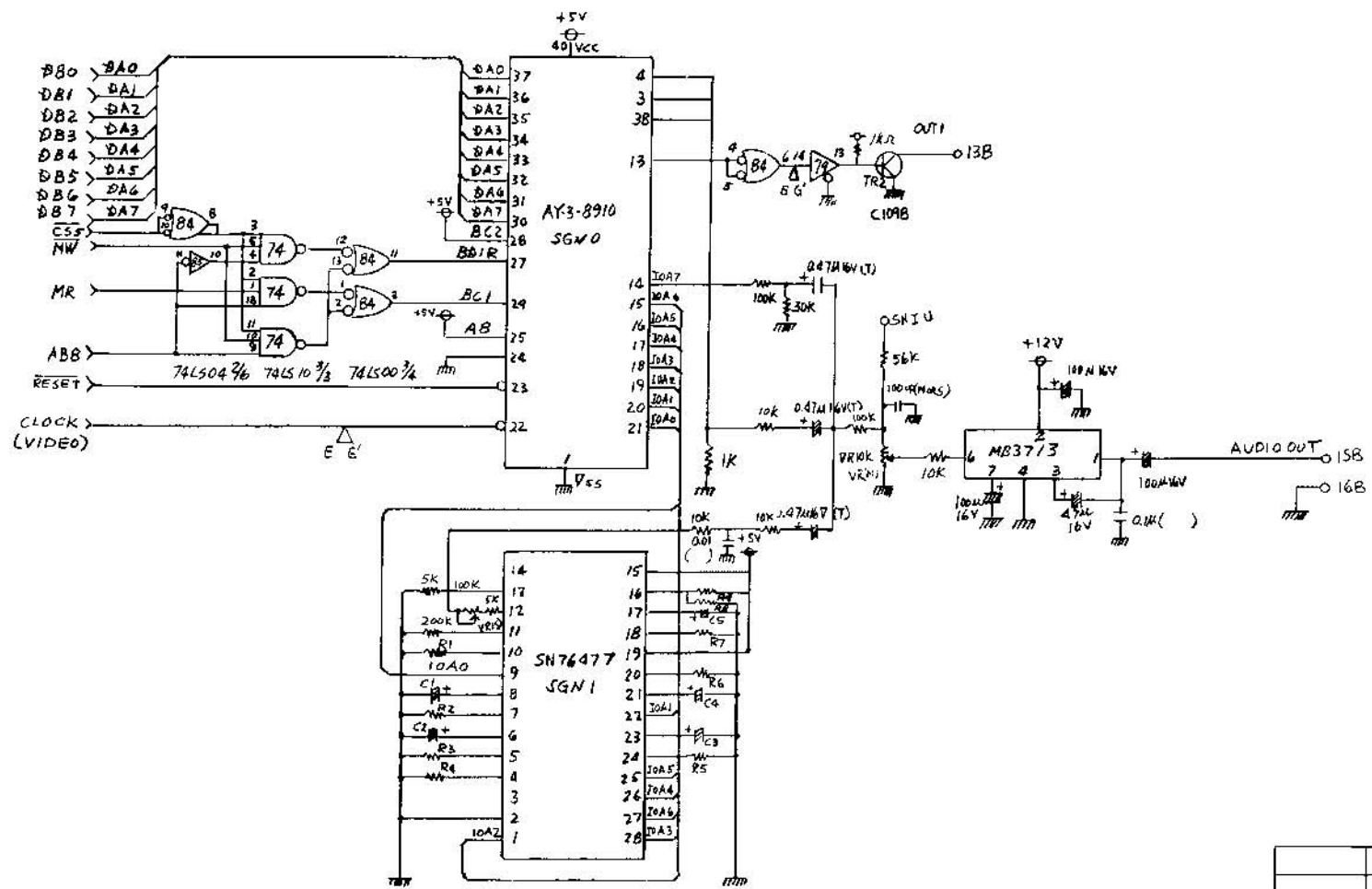

QC. AP'VD	PROD. AP'VD	QTY.	ASSEMBLY NO
-----------	-------------	------	-------------

				TOLERANCES		centron		HIALEAH, FLORIDA 33014	
				Unless Otherwise Specified		NAME			
				FRACTIONS	± 1/32	SOUND BOARD SCHEMATIC - ROUTE 16			
				DECIMALS 2 PL	± .016	MATERIALS			
				DECIMALS 3 PL	± .006	HEAT TREAT.			
				HOLES	± .003	FINISH			
				ANGLES	± 1/2°	DWN. APP'D. DATE SCALE PART NO. REV.			
				SHT. MET BENDS	± 2°	AAN APP'D. 3-27-81 366-10-D400			



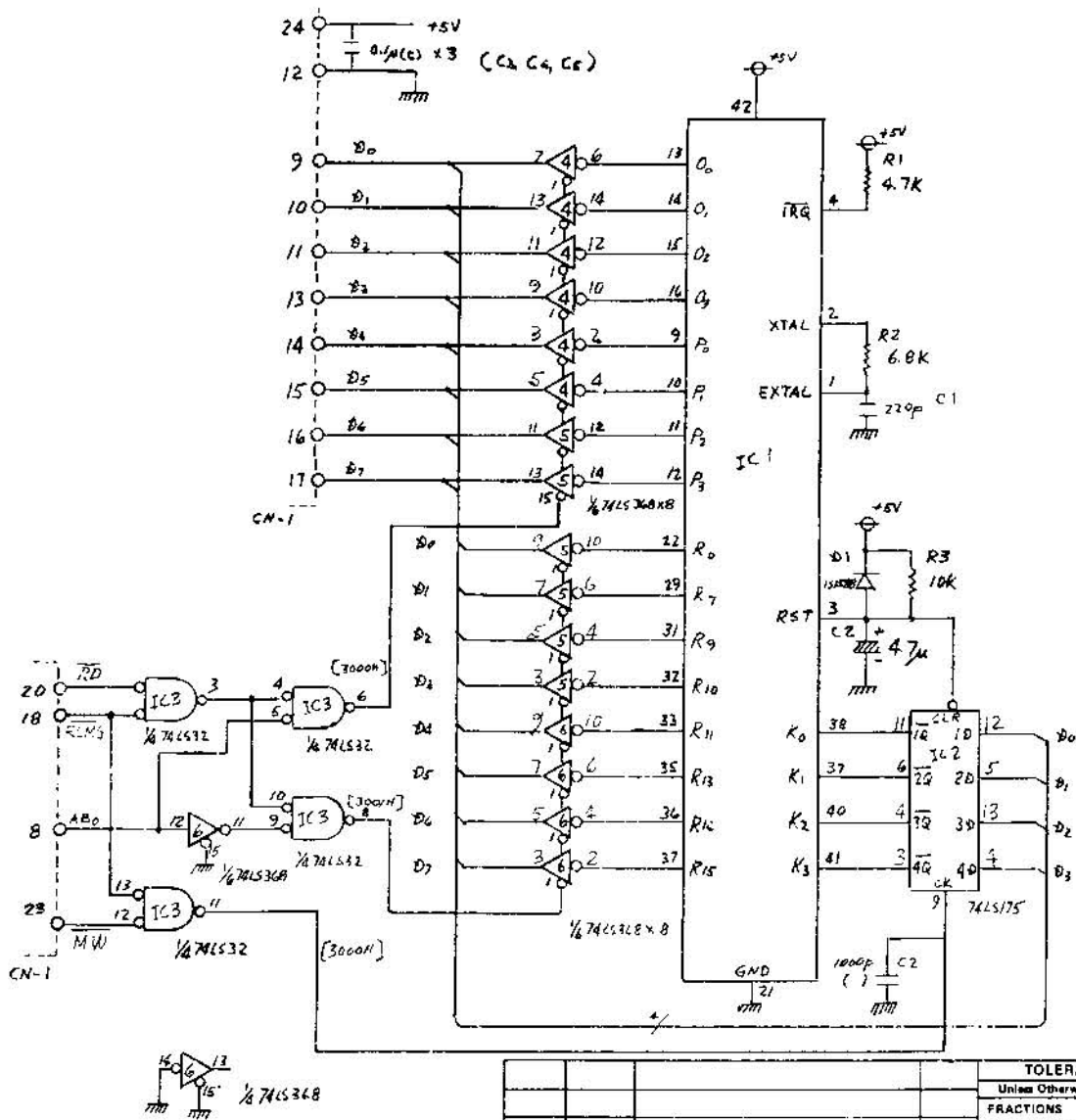

PART NO	NAME	QTY
IC1	42 PIN	1
IC2	74LS175	1
IC3	74LS32	1
IC4-6	74LS368	3
R1	47K	1
R2	7K	1
R3	10K	1
C1	270P(C) CERAMIC	1
C2	4.7 MFD TANTALUM POLYMER CAP. 15V50V	1
D1	1N4148	1
CN-1	3012-12	2

QC. AP'VD	PRDD. AP'VD	QTY.	ASSEMBLY NO

REV. LET.	ECN NO.	REVISION	BY

TOLERANCES	
Unless Otherwise Specified	
FRACTIONS	± 1/32
DECIMALS 2 PL	± 0.18
DECIMALS 3 PL	± .006
HOLES	± .003
ANGLES	± 1/2°
SHT MET BENDS	± 2°

**centon** HIALEAH, FLORIDA 33014

NAME: **S1 BOARD SCHEMATIC-ROUTE 16**

MAT'L'S. HEAT TREAT. FINISH

DWN: **AAN** APP'D. DATE: **3-26-81** SCALE: **≡** PART NO: **366-10-0400** REV.



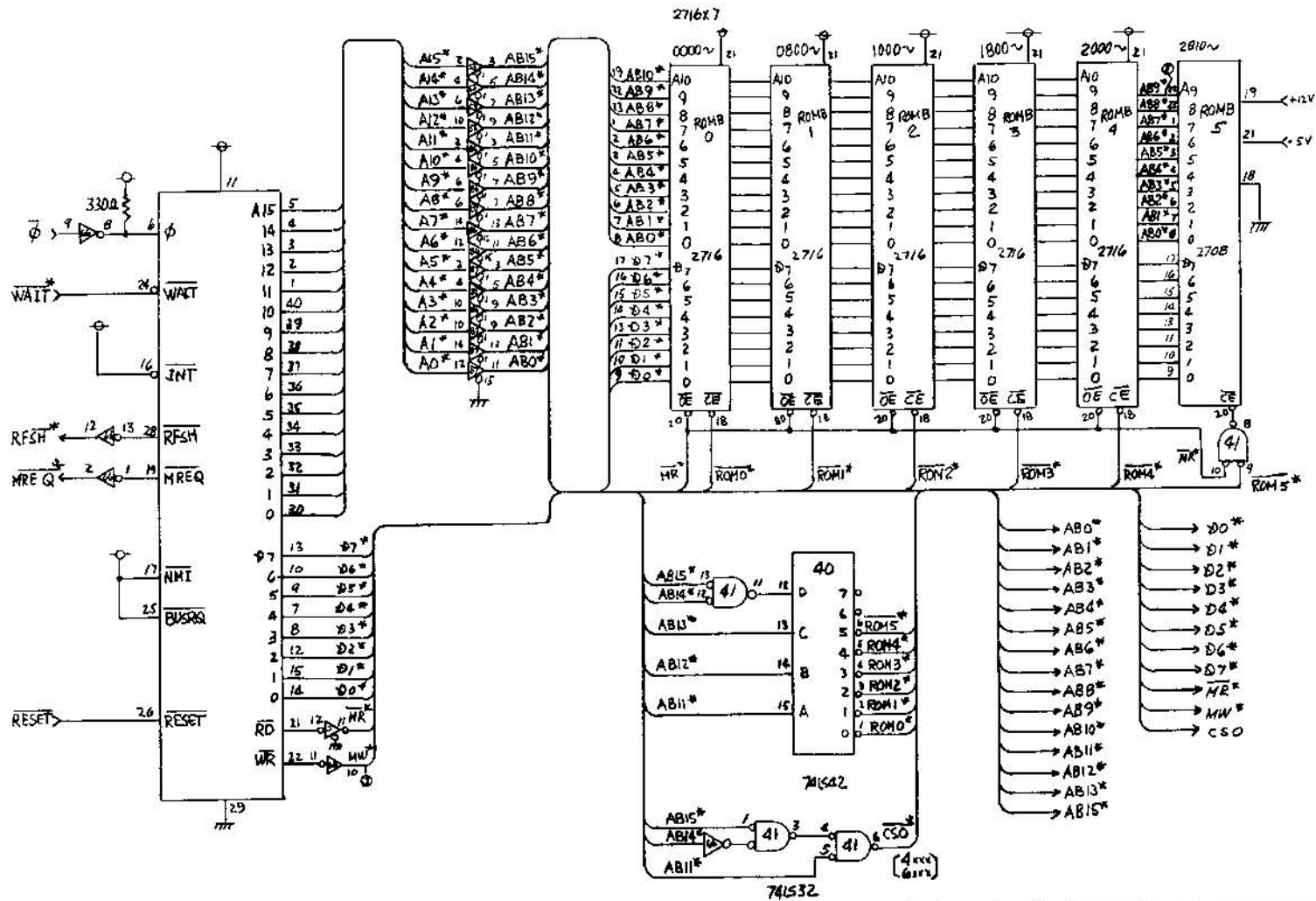

- 74LS42 1
- 74LS367 3
- 74LS32 1
- 74LS04 1
- 2716 [5]
- 2708 [1]
- 280 2

330Ω 1/4W 1

QC. AP'VD	PROD. AP'VD	QTY.	ASSEMBLY NO

TOLERANCES				centurion			
Unless Otherwise Specified				HIALEAH, FLORIDA 33014			
FRACTIONS	±	1/32	NAME	CPU-2 BOARD SCHEMATIC-ROUTE 16			
DECIMALS 2 PL	±	.016					
DECIMALS 3 PL	±	.006					
HOLE	±	.003	MAT'L'S.	HEAT TREAT.	FINISH		
ANGLES	±	1/2°	DWN	APP'D.	DATE	SCALE	PART NO.
SMT. MET BENDS	±	2°	AAN		3-25-81		366-10-0400