

QWAK

Operation and Maintenance Manual

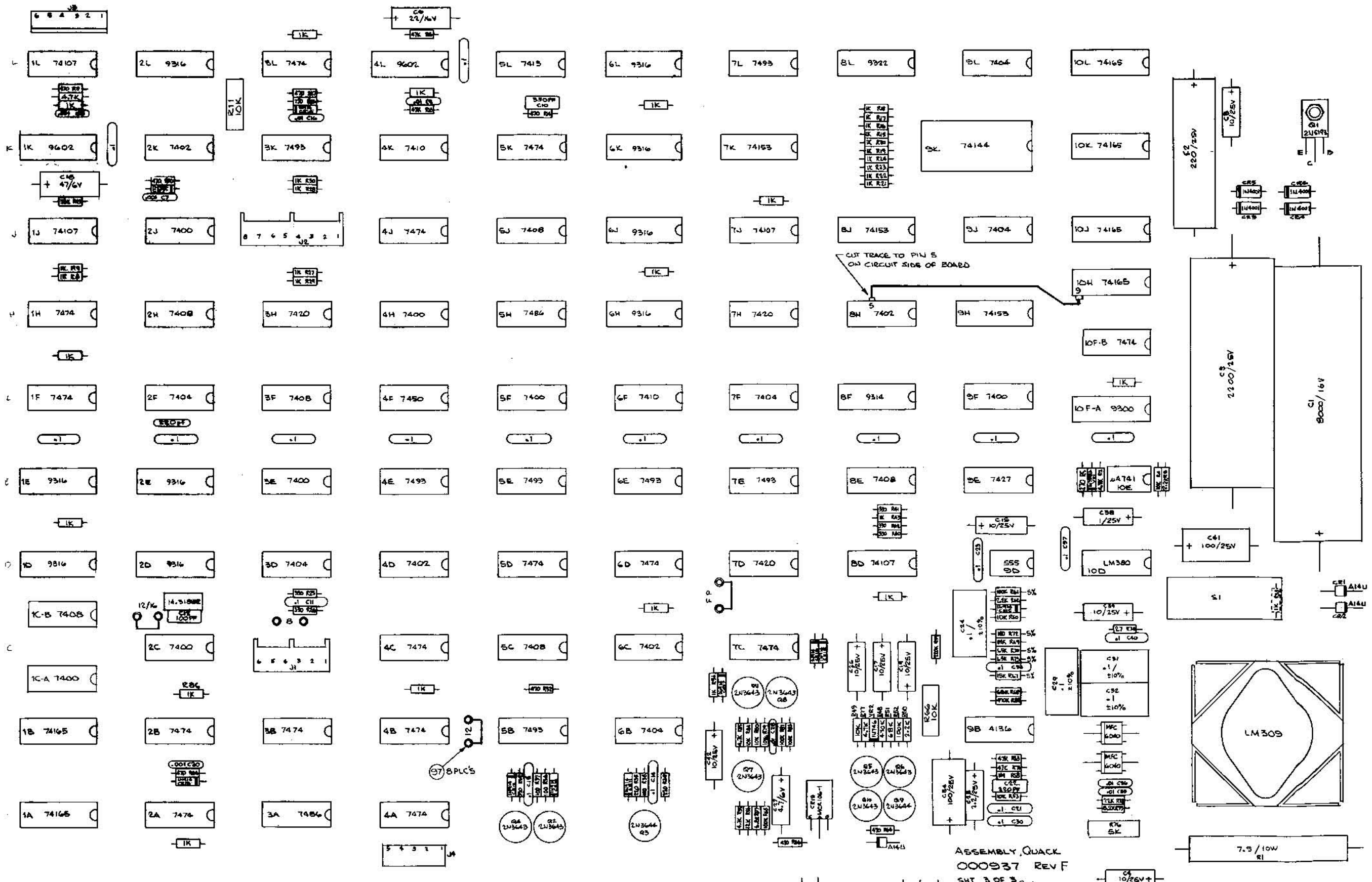



CUT TRACE TO PIN 5 ON CIRCUIT SIDE OF BOARD

ASSEMBLY QUACK
000937 REV F

F	REV PER BAW 565
E	REV PER BAW 565
D	REV PER BAW 565

SHT 3 OF 3
PDR BAW -
RFG BAW -

REV	DESCRIPTION	DATE	BY	CHKD
C	PRODUCTION RELEASE	8/15/74		
D	REVISED PER ECU	8/15/74		
E	REVISED PER ECU	8/15/74		
F	REVISED PER ECU	8/15/74		

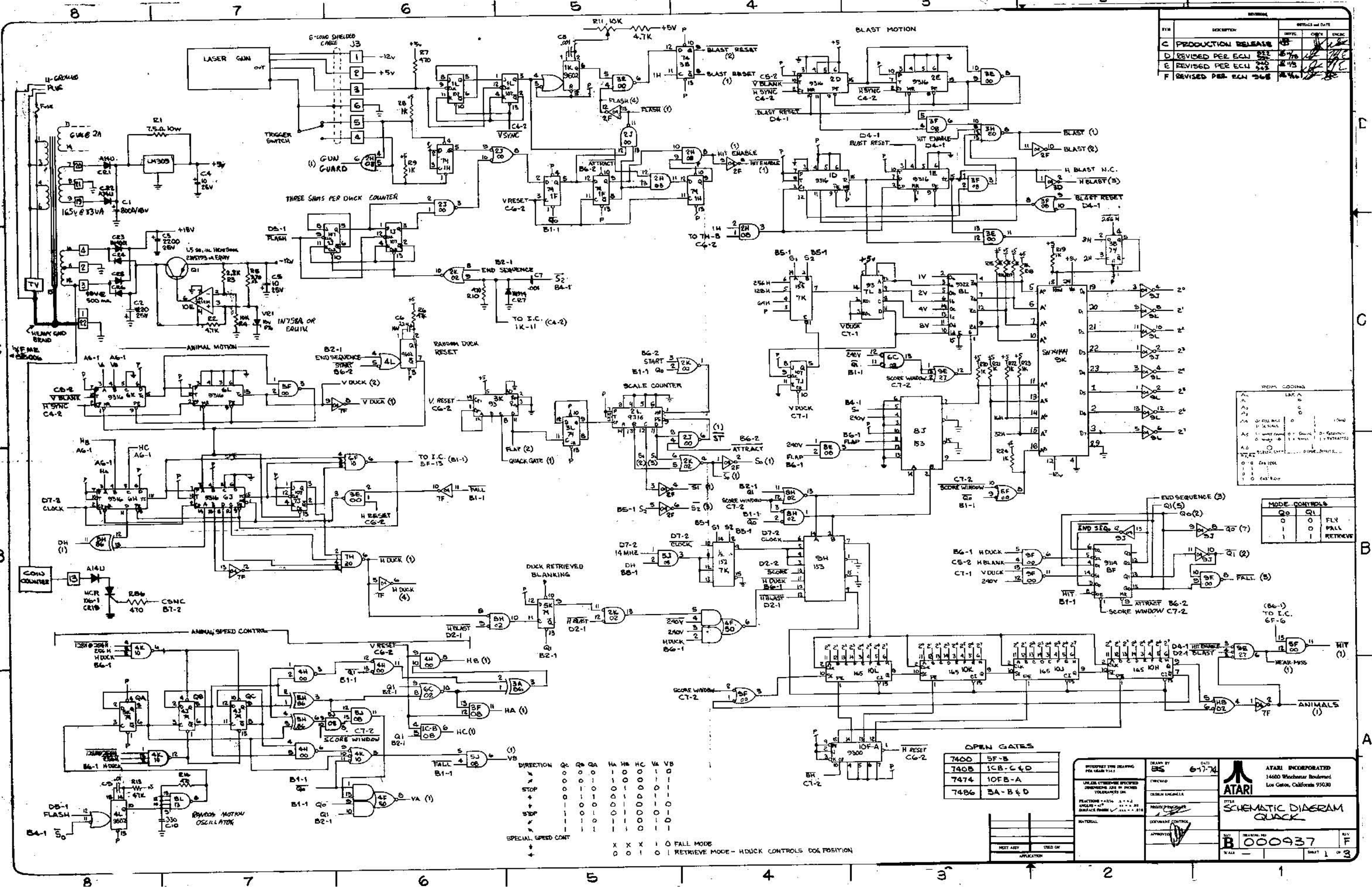

DEPT. CODING

A1	LAKE	0
A2	LAKE	0
A3	LAKE	0
A4	LAKE	0
A5	LAKE	0
A6	LAKE	0
A7	LAKE	0
A8	LAKE	0
A9	LAKE	0
A10	LAKE	0
A11	LAKE	0
A12	LAKE	0
A13	LAKE	0
A14	LAKE	0
A15	LAKE	0
A16	LAKE	0
A17	LAKE	0
A18	LAKE	0
A19	LAKE	0
A20	LAKE	0

MODE CONTROLS

Q0	Q1	FLY
0	0	0
1	0	FALL
1	1	RETRIEVE

OPEN GATES

7400	5F-B
7408	1CB-C & D
7474	10FB-A
7486	3A-B & D

DESIGN AND CHECK

DESIGNED BY	ES	DATE	6-17-74
CHECKED BY			
DESIGN ENGINEER			
PRODUCTION			
DOCUMENT CONTROL			
APPROVED			

ATARI INCORPORATED
14600 Woodchester Boulevard
Los Gatos, California 95030

ATARI

TITLE
**SCHEMATIC DIAGRAM
QUACK**

REVISION
B 000937

REV
F

PAGE
1 OF 3

SPECIAL SPEED CONT
 X X X 1 0 FALL MODE
 0 0 1 0 1 RETRIEVE MODE - H DUCK CONTROLS DOG POSITION

ITEM	DESCRIPTION	INITIALS AND DATE		
		DESIGN	CHECK	DATE

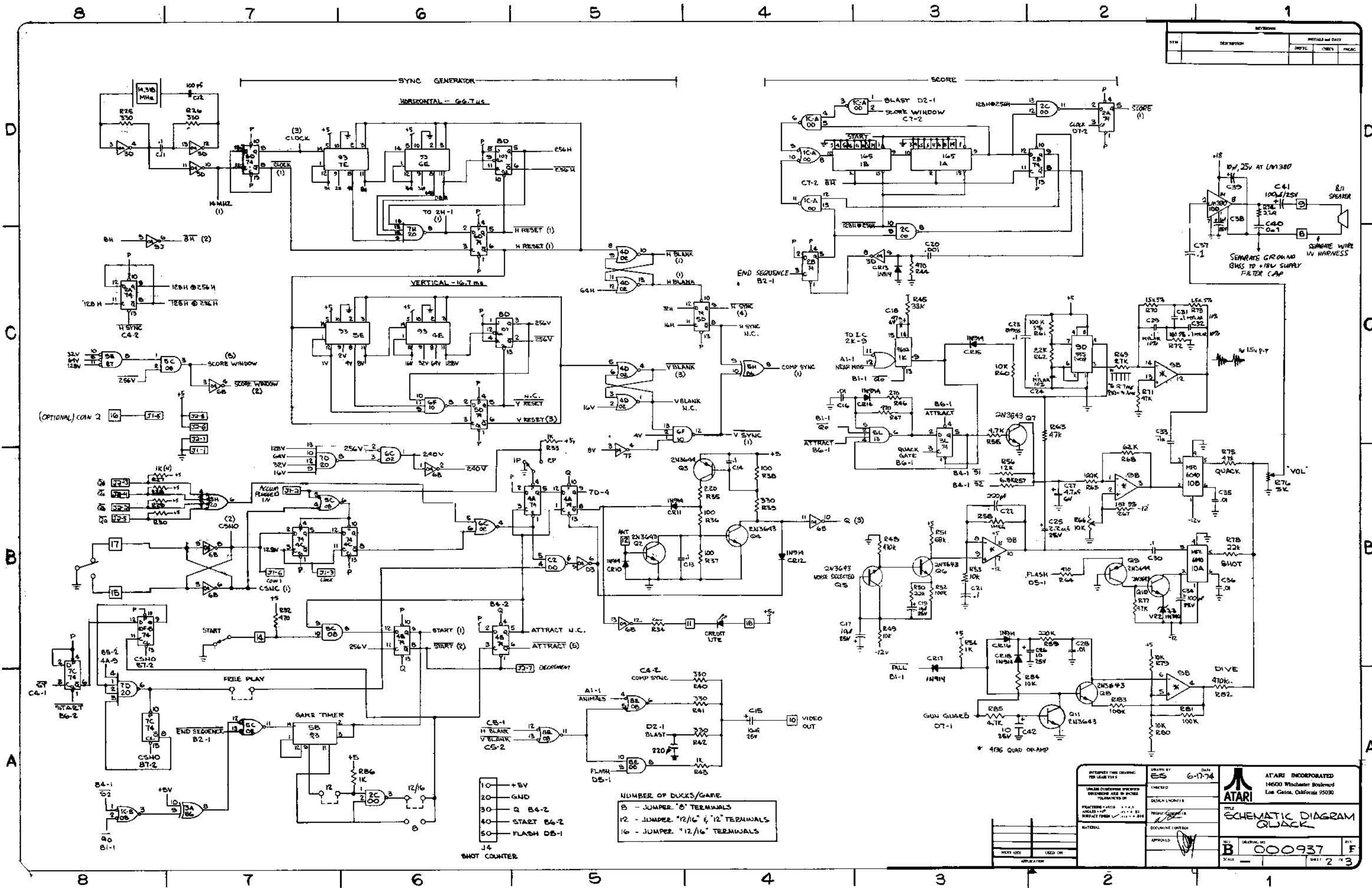

- NUMBER OF DUCKS/GAME
- B - JUMPER "B" TERMINALS
 - 12 - JUMPER "12/16" & "12" TERMINALS
 - 16 - JUMPER "12/16" TERMINALS
- J4
SHOT COUNTER
- 10 - +5V
 - 20 - GND
 - 30 - Q B4-2
 - 40 - START B6-2
 - 50 - FLASH D5-1

INTERPRET THIS DRAWING FOR LEAD 114 UNLESS OTHERWISE SPECIFIED DIMENSIONS ARE IN INCHES TOLERANCES IN PARENTHESES FINISHES: *AT14 - 1/16" UNLESS OTHERWISE SPECIFIED UNLESS OTHERWISE SPECIFIED SURFACE FINISH: *A14 - 1/16" UNLESS OTHERWISE SPECIFIED	DRAWN BY ES CHECKED BY DESIGN LENGTH BY PROJECT NUMBER BY DOCUMENT CONTROL APPROVED 	DATE 6-17-74 ATARI INCORPORATED 14500 Winchester Boulevard Los Gatos, California 95030 ATARI TITLE SCHEMATIC DIAGRAM QUACK SHEET NO. B DRAWING NO. 000937 REV. F SHEET 2 OF 3
--	--	---

8

7

6

5

4

3

2

1

SYM	DESCRIPTION	INITIALS and DATE		
		DWG	CHECK	ENGR
A	PROD REL	10-5-74	AG	
B	REV PER BEN BGG	10-10-74		
C	REV PER ECU BGG	10-17-74		

D

D

C

C

B

B

A

A

TO START SWITCH

TO CASH DOOR

TO SPEAKER

TO PC BOARD

TO TOP REX RETAINER

95V (16)
 110V (17)
 220V (18)

2 REQD (12)
 (3)
 (7)

2 REQD (10)
 (7)

(13)
 (7) 5 REQD

(2)
 (3)
 (7) 4 REQD

(11)
 (7) 2 REQD

(6)
 (14)
 (7) 2 REQD

(8)
 (9)
 (7)

(5)
 (7) 4 REQD

INTERPRET THIS DRAWING PER USAR 716.5 UNLESS OTHERWISE SPECIFIED DIMENSIONS ARE IN INCHES TOLERANCES ON: FRACTIONS ± .014 ANGLES ± .4° SURFACE FINISH ✓ ± .0005 A .016	DRAWN BY AG	DATE 10-1-74	 ATARI INCORPORATED 14600 Wilshire Boulevard Los Gatos, California 95030
	CHECKED DESIGN ENGINEER	PROJECT ENGINEER	
MATERIAL: SEE P. 001918	APPLICATION NEXT ASSY USED ON		TITLE ASSEMBLY, ELECTRONICS TRAY
SIZE D	DRAWING NO. A001978	REV C	SCALE SHEET 1 OF 1

DRAWING NO.
 A001978
 SHEET
 1
 REV
 C

8

7

6

5

4

3

2

1

8 7 6 5 4 3 2 1

REVISION				
SYM	DESCRIPTION	INITIALS and DATE		
		DRFTG	CHKD	ENGRG
A	PROD REL	10-27-74	<i>[Signature]</i>	<i>[Signature]</i>
B	REV PER ECU 93%	11-1-74	<i>[Signature]</i>	<i>[Signature]</i>

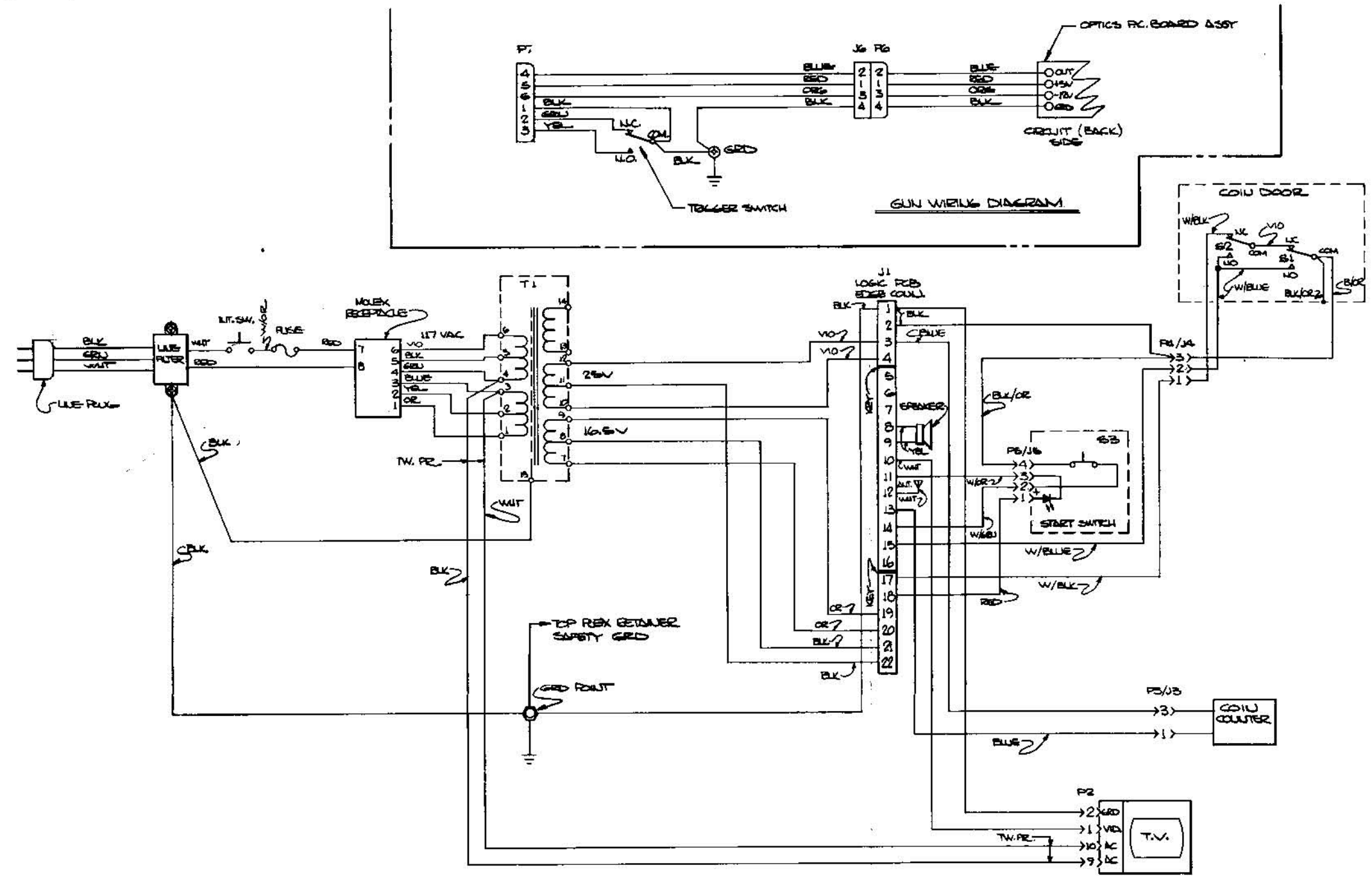

D
C
B
A

D
C
B
A

DRAWING NO. 002485
SHEET 1 OF 1

INTERPRET THIS DRAWING PER UGAS Y14.1 UNLESS OTHERWISE SPECIFIED DIMENSIONS ARE IN INCHES TOLERANCES ON: FRACTIONS = ±.015 ANGLES = ±.5° SURFACE FORM = SEE A. 810	DRAWN BY: <i>COOK</i> DATE: <i>10-27-74</i> CHECKED: DESIGN ENGINEER: PROJECT ENGINEER: DOCUMENT CONTROL:	ATARI INCORPORATED 14600 Winchester Boulevard Los Gatos, California 95030 TITLE: WIRING ENCLOSURE DIAG. "QWAK"
	MATERIAL: NEXT ASSY: <i>ADDISIA</i> USED ON: <i>ADDISIA</i> APPLICATION:	

8 7 6 5 4 3 2 1

8 7 6 5 4 3 2 1

SYM	DESCRIPTION	INITIALS and DATE		
		DRFTD	CHECK	ENGRD
D	FEED GUN REV 4 RECD PER ECN 928	11-19-74	[Signature]	[Signature]
E	REV PER ECN 963	11-26-74	[Signature]	[Signature]
F	REVISED PER ECN 977	12-10-74	[Signature]	[Signature]

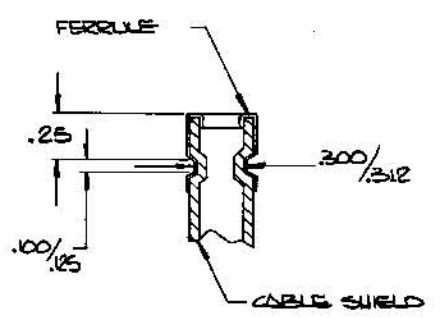

CRIMP FERRULES AS SHOWN
2 PLACES
DETAIL A

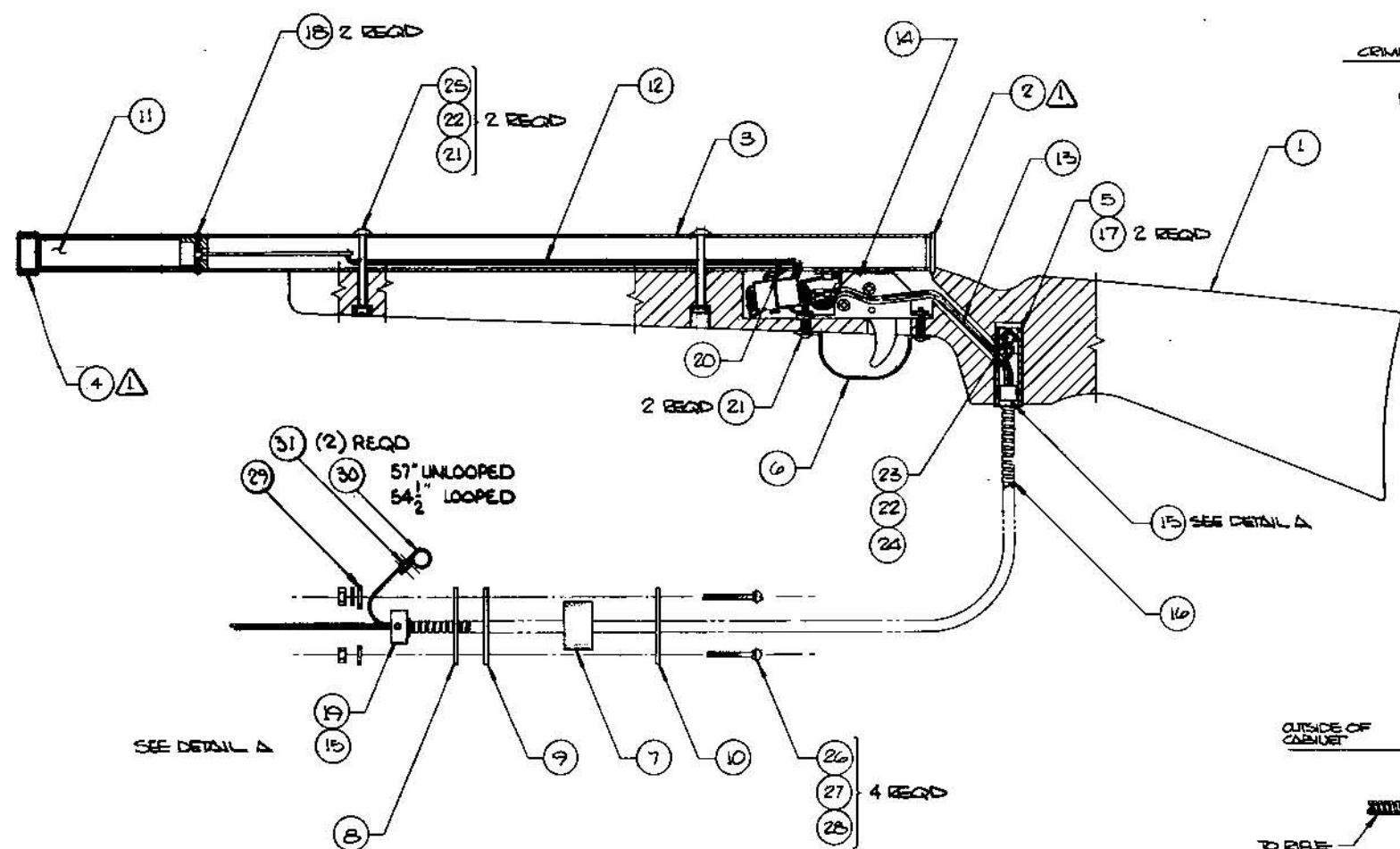

NOTES:
 ⚠ BARREL CAP (ITEM 2) & BUMPER (ITEM 4)
 SHALL BE SECURELY BONDED TO
 GUN BARREL (ITEM 3).

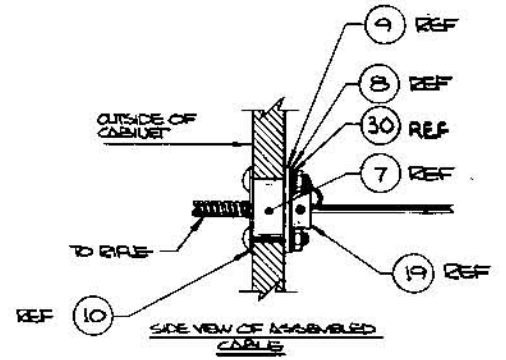

SEE DETAIL A

DRAWING NO. 10001840-1 SHEET 1 OF 1

INTERPRET THIS DRAWING PER ISIRI 1146	DRAWN BY: COOL DATE: 11-18-74	ATARI INCORPORATED 14600 Winchester Boulevard Los Gatos, California 95030
UNLESS OTHERWISE SPECIFIED DIMENSIONS ARE IN INCHES TOLERANCES ON:	CHECKED:	
FRACTIONS - 1/16 3/32 1/8 1/4 3/8 1/2 3/4 1 ANGLES - 45° 90° 135° SURFACE FINISH - 32 64 125 250 500 1000 2000	DESIGN ENGINEER:	PROJECT ENGINEER: DOCUMENT CONTROL:
MATERIAL: SEE PL 001840	APPROVED: [Signature]	SCALE: SHEET 1 OF 1

8 7 6 5 4 3 2 1



Job Title P.C. BOARD ASSEMBLY - QUACK Dwg. P/L 000937

Parts List Specification sheet 1 of 3

Drawn R. Milner
 Checked *[Signature]* 3 Mech. Eng.
 Proj. Eng. *[Signature]* Elec. Eng. *[Signature]* Rev. F

Rev.	Description	Apprv.	Rev.	Description	Apprv.
A	Release for Prod.	<i>[Signature]</i> 10-13-74			
B	Revise per ECN 814	<i>[Signature]</i> 9-27-74			
C	Rev. Per ECN 872 10-	<i>[Signature]</i> 6-74			
D	Rev per ECN 922&932	<i>[Signature]</i>			
E	Rev per ECN 940&943	<i>[Signature]</i>			
F	REV PER ECN 965	<i>[Signature]</i>			

Item	Part. No.	Qty.	Description
	A000937	Ref	Assembly Drawing
1	10101/10-0101	3	Resistor, Carbon, 10%, 1/4 Watt, 100 ohm
2	10102/10-0102	33	" " " " 1K ohm
3	10103/10-0103	7	" " " " 10K ohm
4	10105/10-0105	1	" " " " 1M ohm
5	10221/10-0221	2	" " " " 220 ohm
6	10222/10-0222	3	" " " " 2.2K ohm
7	10223/10-0223	1	" " " " 22K ohm
8	10224/10-0224	1	" " " " 220K ohm
9	10271/10-0271	2	" " " " 270 ohm
10	10123/10-0123	1	" " " " 12K ohm
11	10331/10-0331	6	" " " " 330 ohm
12	10333/10-0333	1	" " " " 33K ohm
13	10471/10-0471	8	" " " " 470 ohm
14	10472/10-0472	5	" " " " 4.7K ohm
15	10473/10-0473	4	" " " " 47K ohm
16	10474/10-0474	2	" " " " 470K ohm
17	10-0104	4	" " " " 100K ohm
18	10683/10-0683	2	" " " " 68K ohm
19	11104/10-5104	1	" " 5% " 100K ohm
20	11152/10-5152	2	" " " " 1.5K ohm
21	11153/10-5153	1	" " " " 15K ohm
22	11181/10-5181	1	" " " " 180 ohm
23	19-313103	2	Trimpot, 10K
24	11270/10-20P7	1	" 10% " 2.7 ohm
25	22502/19-311502	1	Trimpot, 5K
26	30101/28-101101	1	Capacitor, Dipped, Mica, 100 pf
27	30102/28-101221	2	" " " 220 pf
28	30331/28-101331	1	" " " 330 pf
29	34101/27-101104	21	" Ceramic, .1 uf
30	34102/27-101102	3	" " .001 uf
31	34104/27-101103	5	" " .01 uf
32	32101/21-101104	4	" Mylar, 10%, .1 uf
33	35102/24-250105	1	" Electrolytic, 1 uf, 25V
34	35103/24-250106	8	" " 10 uf, 25V
35	35222/24-250225	1	" " 2.2 uf, 25V
36	35472/24-060475	1	" " 4.7 uf, 6V
37	35473/24-060476	1	" " 47 uf, 6V
38	35509/24-160226	1	" " 22 uf, 16V

PARTS LIST SPECIFICATION

Dwg. P/L 000937

Title P.C. BOARD ASSY. - QUACK

sheet 2 of 3

Rev. F

Item	Part No.	Qty.	Description
39	37000/24-160808	1	Capacitor, Electrolytic, 8000 uf, 16V
40	37102/24-250227	1	" " 220 uf, 25V
41	37103/24-250107	2	" " 100 uf, 25V
42	37104/24-250228	1	" " 2200 uf, 25V
43	70000/34-2N3643	8	Transistor, 2N 3643
44	70001/34-2N3644	2	" 2N 3644
45	70004/34-2N5193	1	" 2N 5193
46	71000/31-1N914	10	Diode, 1N 914
47	71001/31-1N4001	4	Diode, 1N 4001
48	71006/31-A14F	3	Diode, 3A, A14F
49	71012/32-1N758	1	Diode, 1N 758, Zener, 10V
50	71013/32-1N746	1	Diode, 1N 746, Zener, 3.3V
51	60000/69-001	1	Switch, DPDT
52	72000/37-7400	7	Integrated Circuit, 7400
53	72001/37-7402	4	" " 7402
54	72002/37-7404	6	" " 7404
55	72003/37-7410	2	" " 7410
56	72004/37-7420	3	" " 7420
57	72006/37-7427	1	" " 7427
58	72009/37-7450	1	" " 7450
59	72010/37-7474	15	" " 7474
60	72012/37-7486	2	" " 7486
61	72014/37-7493	7	" " 7493
62	72015/37-74107	4	" " 74107
63	72016/37-74153	3	" " 74153
64	72017/37-9316	9	" " 9316
65	72018/37-555	1	" " 555
66	72025/37-9322	1	" " 9322
67	72026/37-9602	2	" " 9602
68	72027/37-7408	6	" " 7408
69	72033/37-74165	6	" " 74165
70	72036/37-9314	1	" " 9314
71	72042/37-MFC6040	2	" " MFC 6040
72	72050/37-7413	1	" " 7413
73	72051/37-ua741	1	" " ua 741
74	72048/37-LM380	1	" " LM 380
75	72052/37-RC4136D	1	" " RC 4136 D
76	72019/37-LM309	1	LM 309 K
77	72074/37-2530N	1	Custom ROM, 2530 N
78	75100/72-1610C	2	Screw, Pan Head, Phil., Stainless, #6-32 x 5/8" Lg.
79	75101/75-056	2	Washer, Lock, #6
80	75102/75-016C	2	Washer, Flat, #6
81	75103/75-916S	2	Nut, Hex, #6-32
82	75162/75-044	1	Washer, Split lock, #4
83	75163/75-014S	1	Washer, Flat, #4
84	75164/75-914S	1	Nut, Hex, #4-40
85	75188/75-1408S	1	Screw, Pan Head, Phil., Stainless, #4-40 x 1/2"
86	80086/79-42424	1	Socket, 24 Pin
87	81001/90-101	1	Crystal, 14.318180 mhz
88	83014/78-06001	1	Wakefield Heatsink
89	19112/19-609w7p5	1	Resistor, 10 Watt, Wirewound, 7.5 ohm
90	10682/10-0682	1	" Carbon, 10%, 1/4 Watt, 6.8K ohm

PARTS LIST SPECIFICATION

Dwg. P/L 000937

Title P.C. BOARD ASSY. - QUACK

sheet 3 of 3

Rev. F

Item	Part No.	Qty.	Description
91	10823/10-0823	1	Resistor, Carbon, 10%, 1/4 Watt, 82 K ohm
92	/10-0822	1	" " " " 8.2K ohm
93	71009/35-MCR106-1	1	MCR 106-1
94	/37-9300	1	Integrated Circuit, 9300
95	/79-58017	1	Polarized Wafer, Molex #09-60-1061
96	001873	1	Printed Circuit Board
97	79-20213	8	TERMINAL

QUACK



ASSEMBLY TITLE / Assembly Electronics Tray P/L 001978

PARTS LIST SPECIFICATION

Page 1 of 1

Drawn	
Checked	Mech. Eng.
Proj. Eng.	Elec. Eng
	REV. C

Rev.	Description	Date	Apprv.	Rev.	Description	Date	Apprv.
A	PROD REL	10/4/74	<i>[Signature]</i>				
B	Rev per ECN 862	10/10/74	<i>[Signature]</i>				
C	Rev per ECN 886	10/17/74	<i>[Signature]</i>				

Item	Part Number	Qty.	DESCRIPTION
1	A001994	1	Assembly, Harness
2	000622	1	Cover, Transformer
3	000871	1	Label
4	A001979	1	Assembly, Tray/Cleat
5	55006/000855	1	Transformer
6	80029/71-2121	2	AC Power Interlock Switch
7	75200/72-6602	22	Screw, SM, Pan Hd., Phil., #6 x 1/2 Lg.
8	80001/79-3201	1	Fuse Holder
9	80002/46-2011	1	Fuse, 1 amp, Slo-Blo
10	80004/47-1001	1	Counter
11	90-3001	1	Filter, Power Line
12	83015/54-041	1	Power Cord, 8'
13	78-25001	7	Cable Clamp
14	83097/000268	2	Bracket, Switch Mounting
15	A001920	1	Harness, Voltage Selection
16	*A001921-01	A/R	Shorting Block, 95V
17	*A001921-02	A/R	Shorting Block, 110V
18	*A001921-03	A/R	Shorting Block, 220V

* Install Shorting Block per Voltage Required



ASSEMBLY TITLE / ASSEMBLY, RIFLE QUACK P/LA001840

PARTS LIST SPECIFICATION Page 1 of 1

Drawn	
Checked	Mech. Eng.
Proj. Eng. <i>J</i>	Elec. Eng. <i>[Signature]</i>
	REV. F

Rev.	Description	Date	Apprv.	Rev.	Description	Date	Apprv.
D	PROD REL/ECN 958	11-19-74	<i>[Signature]</i>				
E	Rev per ECN 963	11-26-74	<i>[Signature]</i>				
F	Rev per ECN 977	12-10-74	<i>[Signature]</i>				

Item	Part Number	Qty.	DESCRIPTION
1	001847	1	Gun Stock
2	001843	1	Cap, Barrel
3	001846	1	Barrel, Gun
4	001841	1	Bumper
5	001853	1	Adapter, Cable
6	001848	1	Guard, Trigger
7	001941	1	Cable Support
8	001940	1	Clamp, Cable
9	001942	1	Mount, Shock
10	001939	1	Plate, Cable
11	A001852	1	Assembly, Optics
12	A002460	1	Assembly, Harness, Optics
13	A002458	1	Assembly, Harness, Gun
14	A001850	1	Assembly, Trigger
15	82-701	2	Ferrule
16	78-2000109L	54"	Cable, Stripwound
17	75-4103	2	Screw, Set, Cup Point, Allen, Stl, 10-24 x .19 LG.
18	73-1204	2	Screw, Drive, Rd Hd, .12 x .25 LG.
19	73-660707	1	Collar Set
20	75-6806	1	Screw, Sm, Pan Hd, #8 x .38 LG.
21	82-8812	4	Screw, Button Hd, #8-32 x .75 LG.
22	75-020S	3	Washer, Flat, Narrow Pattern, #10
23	82-302	1	Post, 1 1/4" LG.
24	82-8806	1	Screw, Button Hd Socket Cap #8-32 x .38 LG.
25	82-301	1	Post, 2" LG.
26	75-045	4	Washer, Stl, Lock # 1/4
27	75-9155	4	Nut, Stl, Hex # 1/4-20
28	75-5524N	4	Bolt, Stl, Carriage, 1/4-20x1-1/2 lg.
29	75-025S	1	Washer, Flat (1/4)
30	85-101	57"	Cable, Aircraft (unlooped) (500 lbs test)
31	78-23111	2	Sleeve, Air Cord