

Q*bert^{T.M.}

Instruction Manual

Gottlieb
AMUSEMENT GAMES

165 W. Lake Street Northlake, IL 60164
(312) 562-7400 Telex 72-8463

A Columbia Pictures Industries Company 

Q*BERT (GAME GV-103A) INSTRUCTION MANUAL

TABLE OF CONTENTS

SEC.		PAGE
I.	INSTALLATION	1
II.	INITIALIZATION	3
III.	GAME OPERATION	3
IV.	GAME PLAY AND SCORING	4
V.	SOUND/SPEECH	6
VI.	GAME ADJUSTMENTS/OPTIONS	6
VII.	BOOKKEEPING AND SELF TEST	7
VIII.	GENERAL INFORMATION	9
IX.	THEORY OF OPERATION	11
X.	WIRING AND SCHEMATIC DIAGRAMS	12
XI.	PARTS INFORMATION	33

WARNING: This equipment generates, uses, and can radiate radio frequency energy and if not installed and used in accordance with the instructions manual, may cause interference to radio communications. It has been tested and found to comply with the limits for a Class A computing device pursuant to Subpart J of Part 15 of FCC Rules, which are designed to provide reasonable protection against such interference when operated in a commercial environment. Operation of this equipment in a residential area is likely to cause interference in which case the user at his own expense will be required to take whatever measures may be required to correct the interference."

NOTICE

WARRANTY INFORMATION IS LOCATED ON THE INSIDE BACK COVER.

FOR SERVICE, CALL TOLL FREE: 1-800-323-9121; (ILLINOIS) 1-800-942-1620

I. INSTALLATION

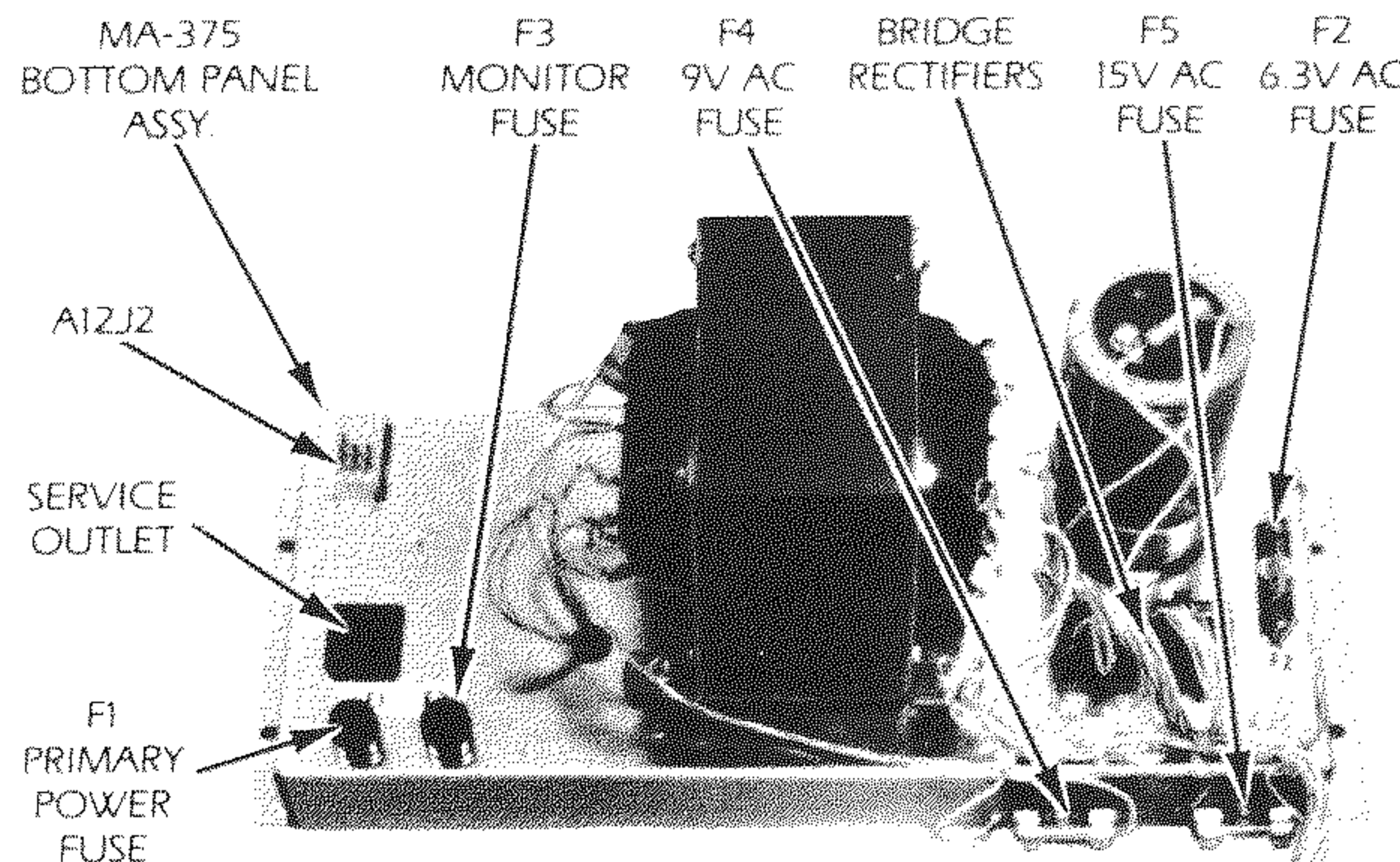
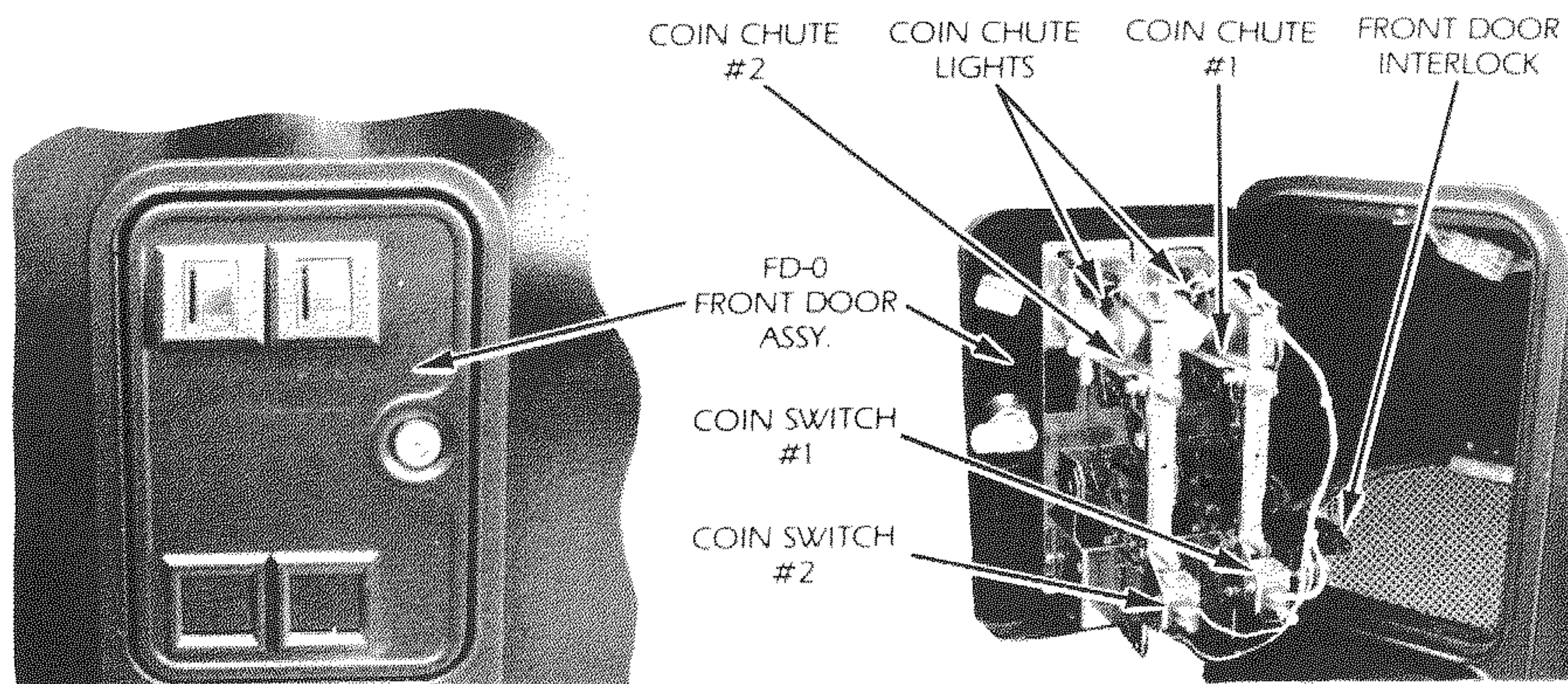
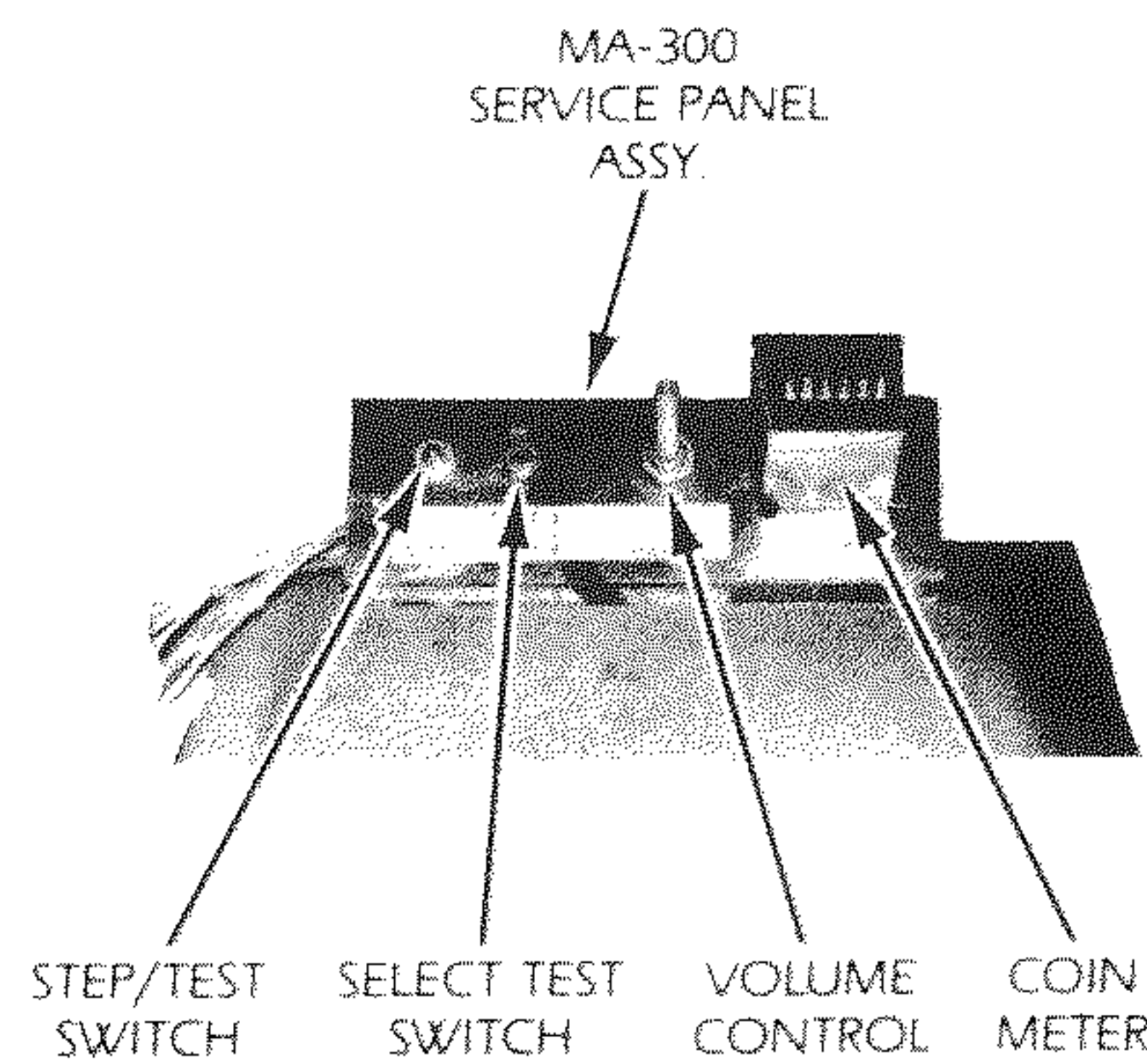
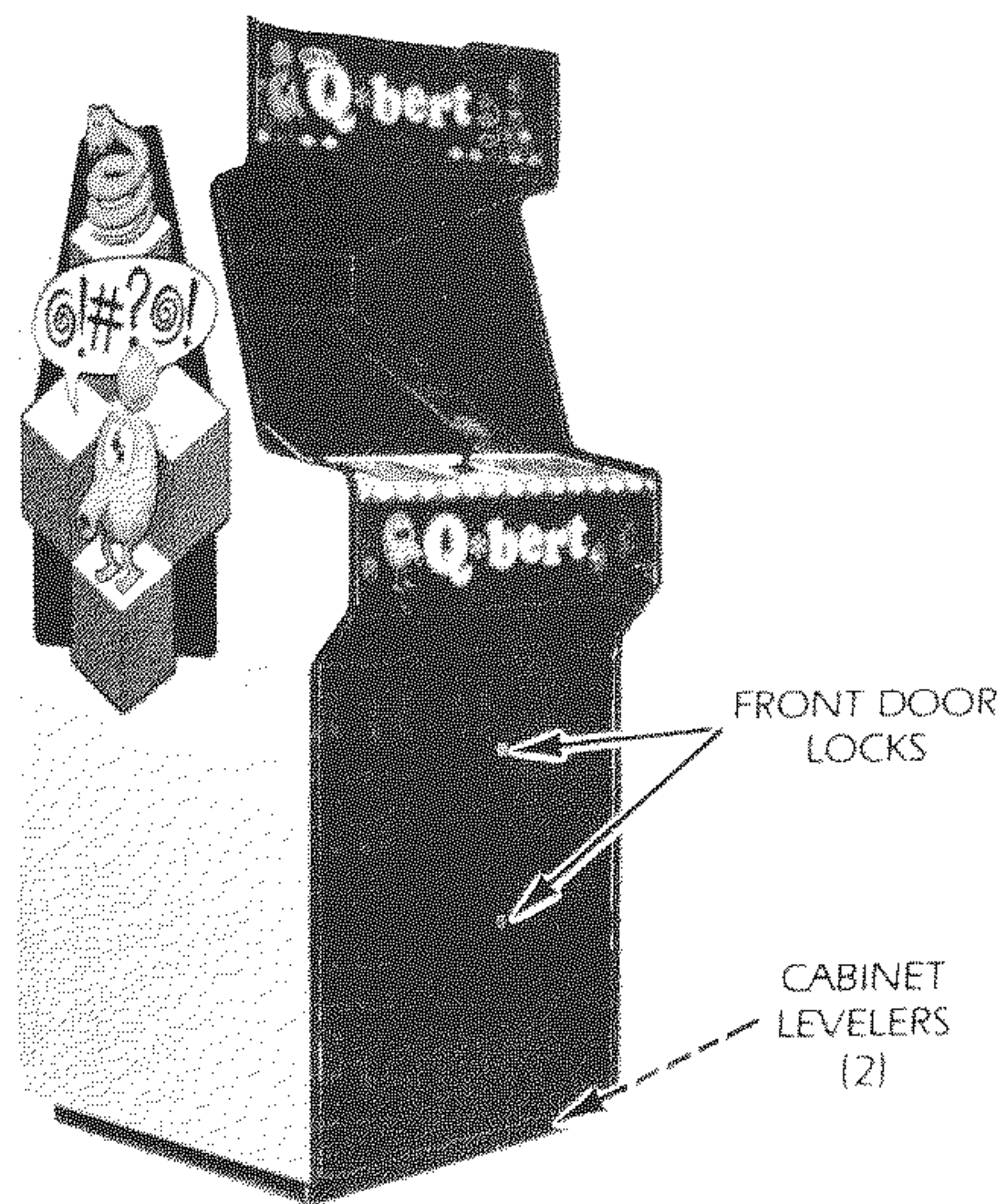
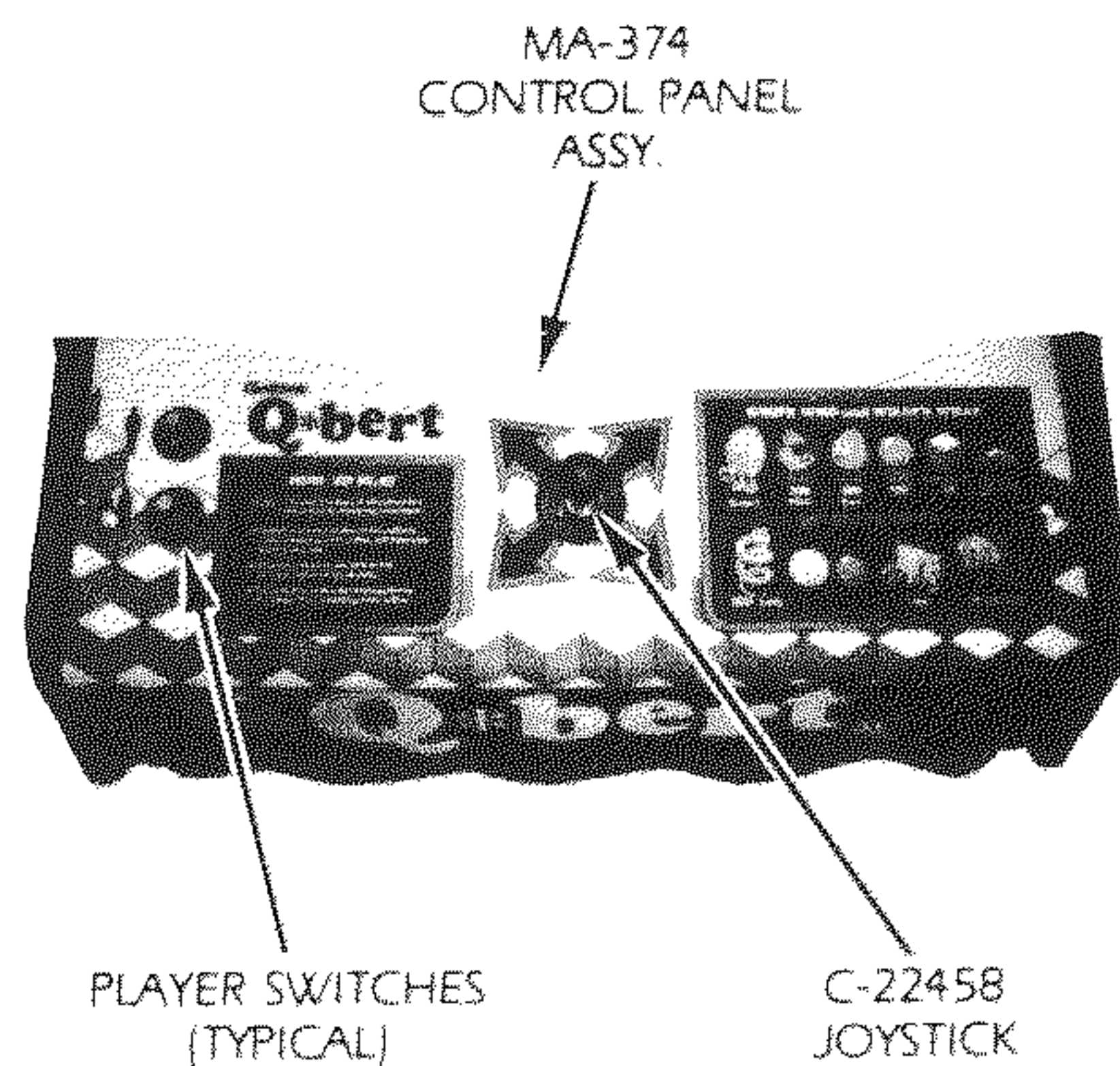
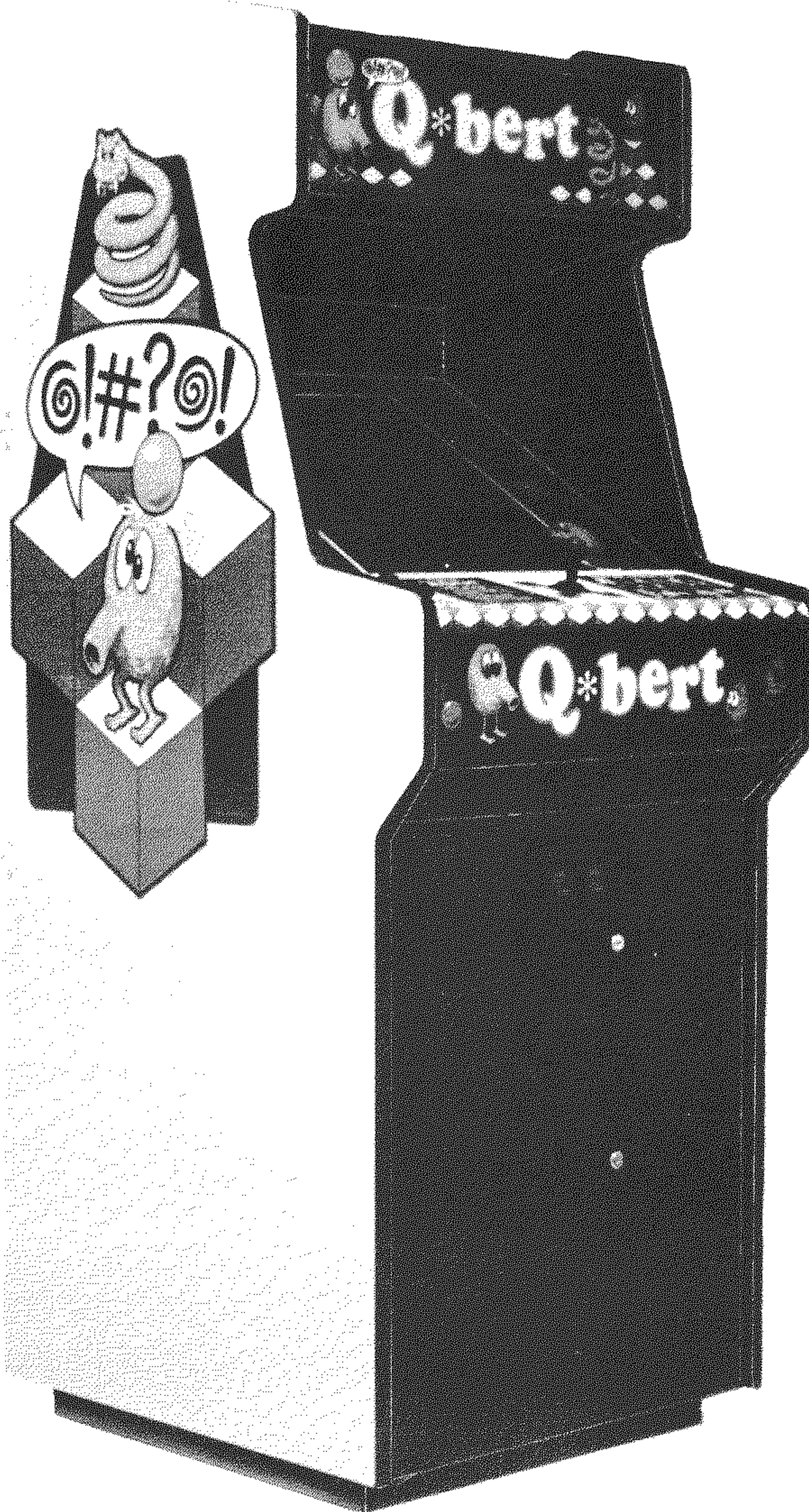
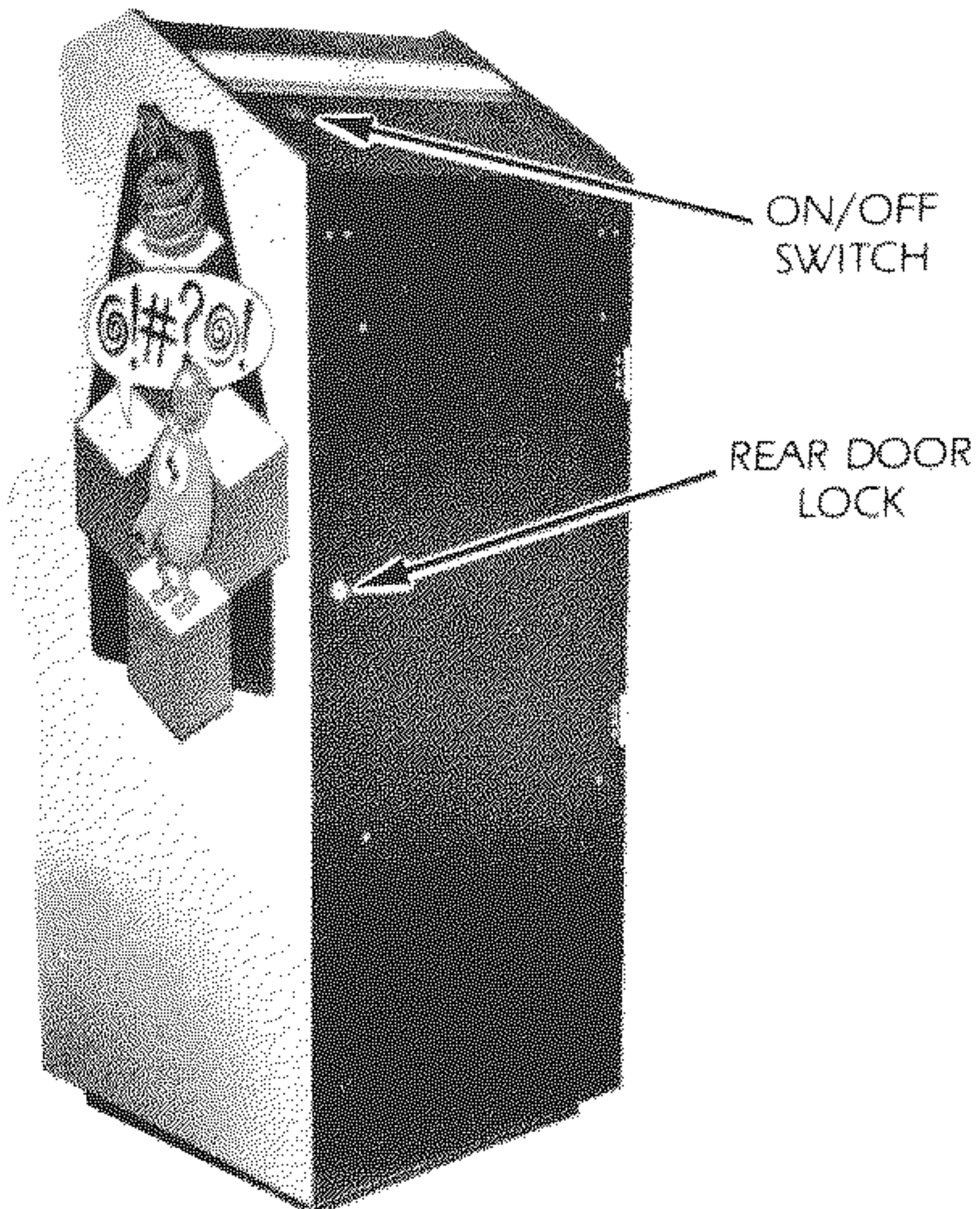
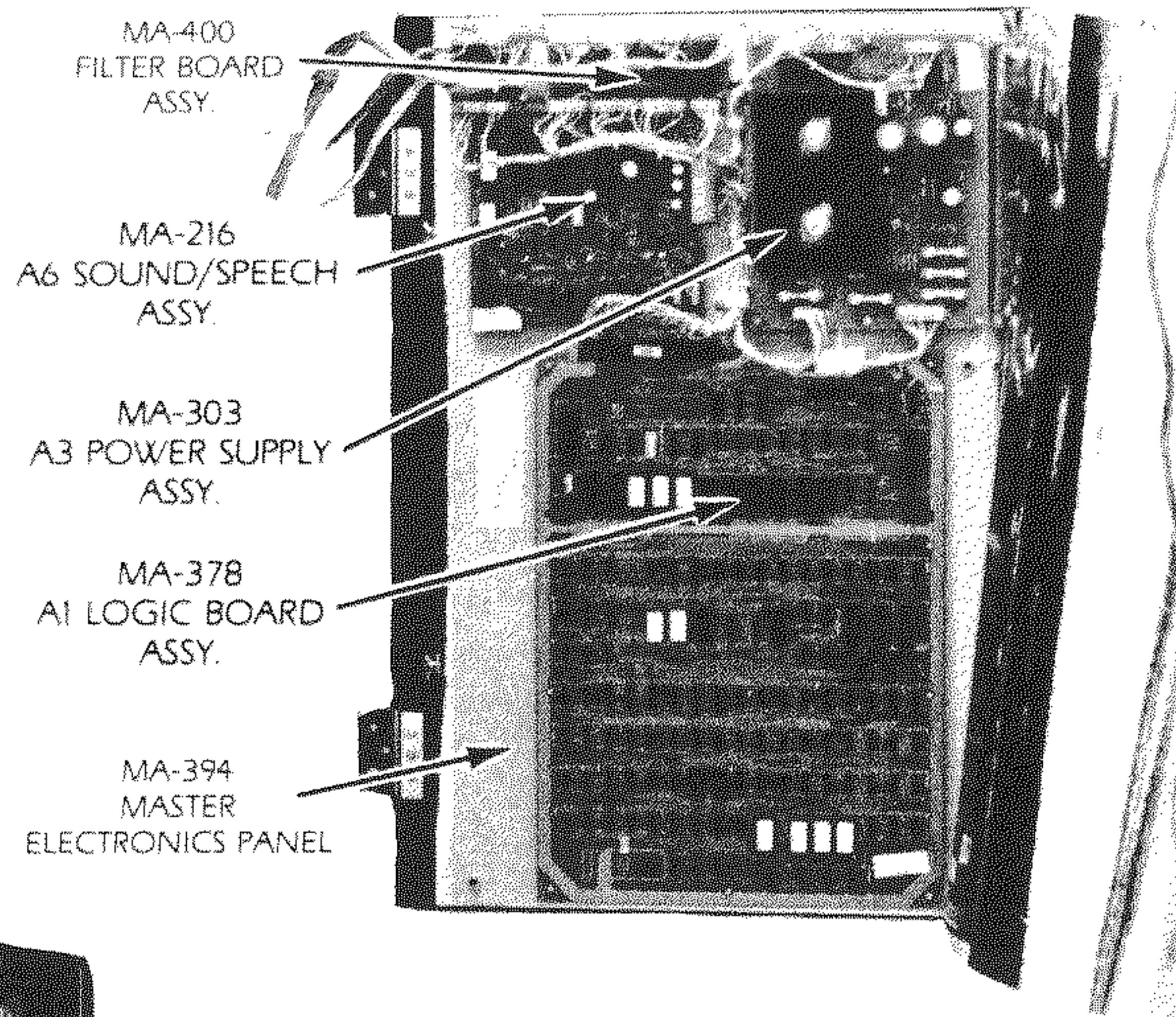
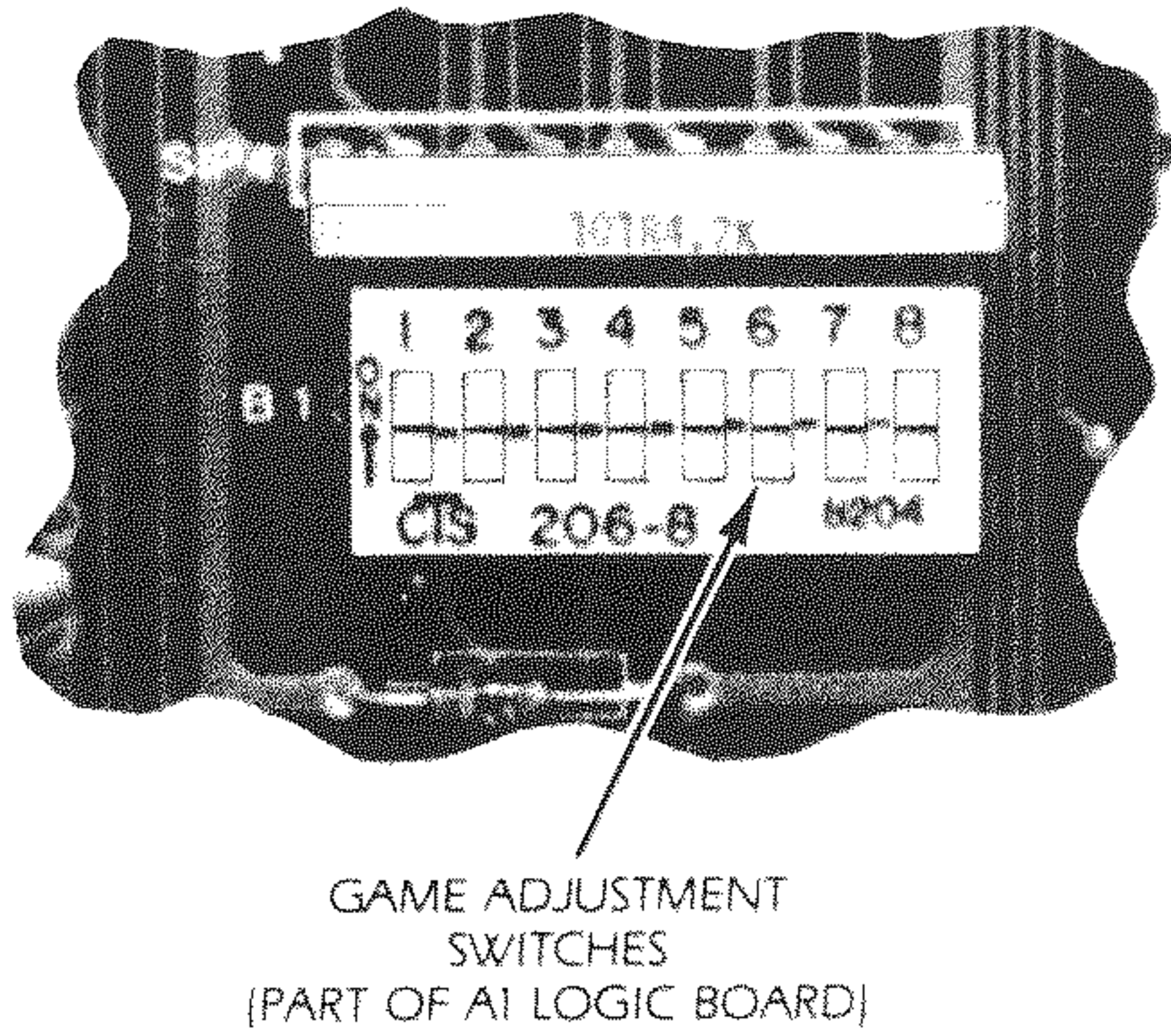
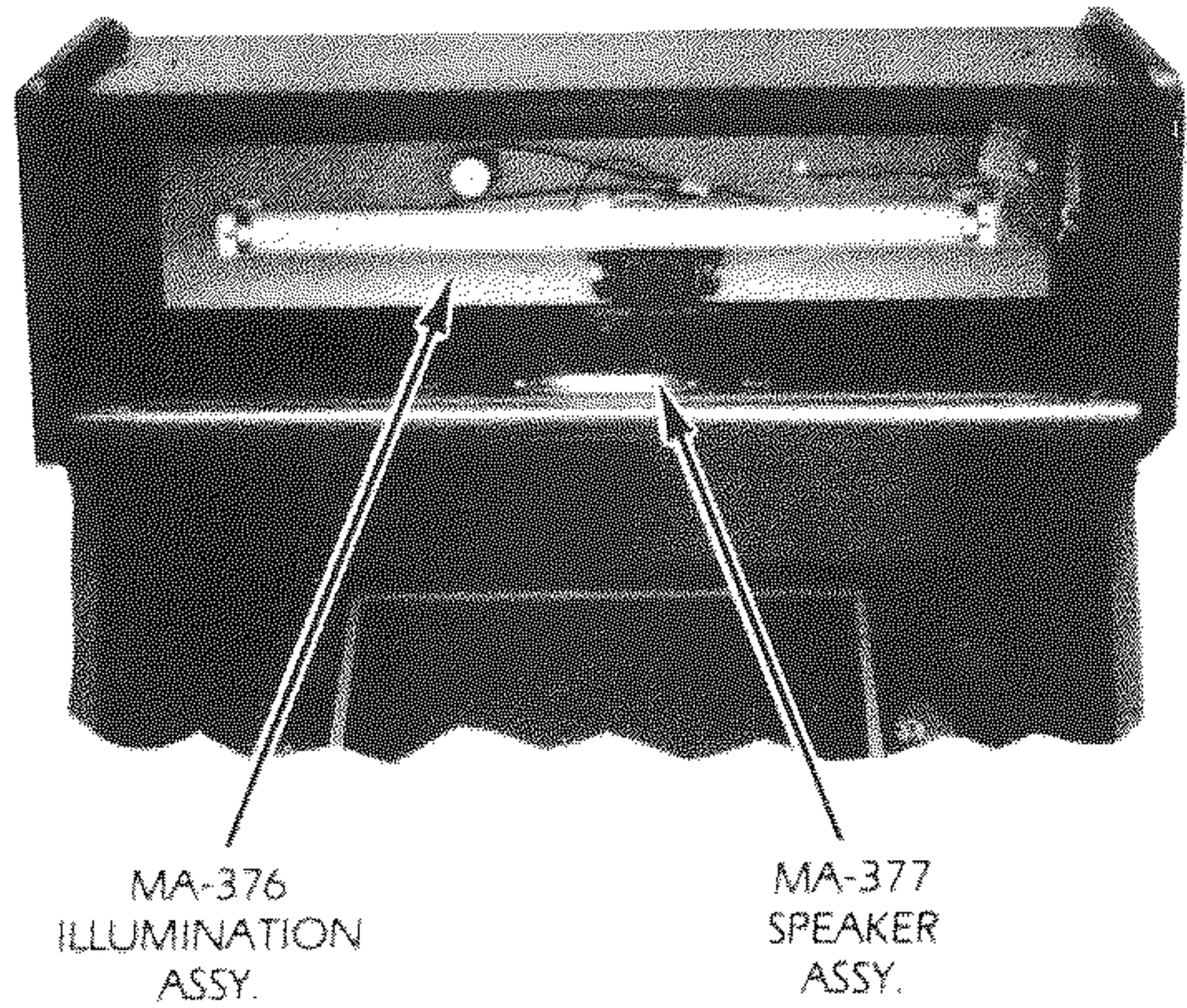

I. INSTALLATION

A. SET—UP

1. Carefully inspect the exterior of the game for any damage which might have occurred during shipment.
2. Unlock and open the rear cabinet door.
3. Check that all plug in connectors are seated firmly. The connectors are keyed so they will only go in one way.
4. Remove the binding strap from the line cord, and install the line cord plate in the groove provided (see photo).
5. Cabinet levelers (2) are stored within the cash box for shipping purposes. Install and adjust as necessary.

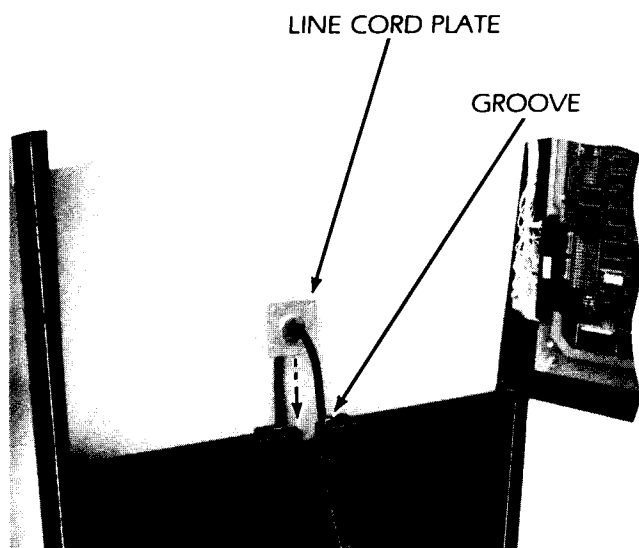

B. CHECK-OUT

1. Check that all cables are free of moving parts.
2. Check for any loose wires.
3. Check for loose solder or foreign matter on switches and power supply assemblies.
4. Be certain all fuses are seated firmly.
5. Be sure transformer wiring corresponds to the supply voltage.
6. Refer to section VI to make all the necessary game adjustments.
7. Reassemble the game.
8. Plug the line cord into a properly grounded 3-wire receptacle ONLY!!

C. CONTROL PANEL REMOVAL

1. Unplug the game.
2. Unlock and open the coin chute door.
3. Reach in through the coin chute door and remove the wing nut and flat washer from each of the two carriage bolts which secure the control panel to the game. Remove the carriage bolts.
4. Pull the control panel back, grasp it at the front edge as far back as it will go (approximately 1/4").
5. Raise the front of the control panel approximately one inch above its supports and lift the entire assembly high enough to disconnect plug A9J2/A9P2.
6. Remove the entire control panel assembly from the game.
7. The Joystick and leaf-switches are now accessible for removal or cleaning.

D. MONITOR REMOVAL

1. Unplug the game.
2. Perform the control panel assembly removal procedure (Section C).
3. Remove the outside shield, glass and monitor mask and put them aside in a secure place.
4. Unlock and open the rear cabinet door.
5. NOTE: The color monitor contains HIGH VOLTAGES delivering LETHAL quantities of energy. Do not attempt to service the monitor until you have shorted the anode plug on the picture tube to ground.
6. Disconnect the video plug A17J1, the monitor power supply plug A12J3/A12P3 and the ground wire from the monitor chassis.
7. From the rear of the game, remove the one nut and one washer from each of the four carriage bolts used to secure the monitor to the platform.
8. Remove the monitor from the rear of the game, being careful to clear all cables from the CRT neck.
9. For reassembly, reverse the above procedure.

II. INITIALIZATION, III. GAME OPERATION

II. INITIALIZATION

TURN GAME ON

Immediately, the coin chute lamps and the speaker marquee lamp will turn on.

AFTER A TEN SECOND DELAY

- A. The attract mode appears on the screen.

- B. The playing field cycles through the follow

1. High Game to Date screen
2. Instruction Set
3. Game Play Cycle

III. GAME OPERATION

A. GAME START

1. Insert coins into coin chute.
 - a. Coin chute tune is played.
 - b. Total credits are displayed on screen.
2. Press one or two player button to start game.
 - a. Demonstration scene displayed on screen.
 - b. Total Credits are decreased by one.
 - c. Game initializes.

B. FIRST PLAYER

1. The first player's score displays a zero.
2. The other player's display will be blank.

C. SECOND PLAYER

1. Additional player is indicated by the words "PLAYER 2" and a zero in the second player's display.

D. "Q*BERTS"/EXTRA "Q*BERTS"

1. Each player will begin with three "Q*Bert" lives. (Dependent on Option/Parameter settings.)
2. Extra "Q*Berts" are earned by achieving certain score levels. (Dependent on Option/Parameter settings.)

IV. GAME PLAY AND SCORING

HOW TO PLAY

The object of the "Q*Bert" game is to change the color of the top of the cubes to the designated color by hopping onto them. When all the cubes in the pyramid have been changed to the designated color, the screen will advance to the next Round, with "Q*Bert" starting back on the top cube. At the beginning of each Level, there will be a short demonstration cycle with the "Q*Bert" character hopping around four cubes to explain to the player the play action of each Level. Each Level consists of four Rounds.

The game play starts with the player-controlled "Q*Bert" character appearing at the top of the pyramid. The joystick will move "Q*Bert" from cube to cube by hopping in any of four diagonal directions. "Q*Bert" can move anywhere on the pyramid, but jumping off will kill him. Hopping on the rotating disk will take "Q*Bert" back to the top of the pyramid. In the first two Rounds "Q*Bert" will have to avoid touching the red and purple balls. These deadly objects drop randomly onto the second-from-the-top level and bounce downwards. The red balls will fall off the bottom but the purple ball will stop at the bottom and hatch into "Coily", the snake which chases "Q*Bert". To destroy the snake, lure him to the edge, then jump unto a disk. The disk will take "Q*Bert" back to the top and "Coily" will fall off, awarding 500 points.

Starting at the third Round, other characters come into play. The green characters or objects are safe to hop onto and will award points. All other objects are deadly to touch. In the third Round the red balls will stop falling, but two purple characters, "Ugg" and "Wrong-Way", will appear at the lower portion of the pyramid and travel sideways and upwards. They will not chase "Q*Bert" but will move randomly to get in "Q*Bert's" way. In the third Round and every Round after, based on an internal timer, a green ball will appear and bounce down from the top of the pyramid. Hopping "Q*Bert" onto the green

ball will award 100 points, and freeze all the characters on the screen for a few seconds, but "Q*Bert" will still be able to move to complete the color changes.

During the third Round of play, two green characters, "Slick" and "Sam", will appear, based on the internal timer. They will drop onto the second level from the top and hop randomly downwards. If they hop onto a cube that "Q*Bert" has already changed the color of, the cube will change to a different color, to thwart "Q*Bert". Hopping "Q*Bert" onto "Slick" or "Sam" will stop them and award 300 points.

Throughout the remaining Rounds, all the characters and objects will appear in random combinations with increasing speed.

To add variety to the game, the disks will change positions every Round, and in the higher Levels the number of disks will change. (See Round Progression Chart.)

During Level Two, the play action will increase in difficulty from changing the cubes to one color, to changing the color of the cubes twice. This means that each cube would have to be hopped on twice to change the pyramid to the designated color, completing the Round.

Starting at Level Three and for all remaining Rounds, and Levels, the play action will become more difficult. The object remains to change the cubes to the designated color, but if "Q*Bert" hops on any cube, that cube will change color. So even if the cube has been changed to the designated color, it will change again.

There are also Bonus points awarded at the end of each Round for successfully completing the Round. The Bonus for the completion of the First Round is 1,000 points. This Bonus will progressively increase each Round by 250 points to a maximum of 5,000 points at Level Five.

CONTROL PANEL INSTRUCTIONS

Goal: Change the tops of all cubes to a new color by hopping onto them.

- Joystick moves "Q*Bert" from cube to cube. Hopping onto a disk will take you back to the top.

- All green objects are safe to hit. All other objects are deadly.
- Destroy the snake by leading him to the edge, then jumping on a disk.
- Stay on pyramid! Only jump off to use a disk.

IV. GAME PLAY AND SCORING

ROUND PROGRESSIONS

The following chart lists round progressions for "Q*Bert".

Commencing with Level V all characters will appear in each subsequent round. The number of disks and the Round Completion Bonus will remain the same value for the rest of the game. The characters and play action will gain more speed with each increased level of play.

	ROUND	DISKS	CHARACTERS ON SCREEN	ROUND COMPLETION BONUS
LEVEL I	1	2	Red Balls, Coily	1000
	2	2	Red Balls, Coily	1250
	3	2	Coily, Green Ball, Ugg/Wrong way, Slick/Sam	1500
	4	2	Red Balls, Coily, Green Ball, Slick/Sam	1750
LEVEL II	1	3	Coily, Green Ball, Ugg/Wrong Way, Slick/Sam	2000
	2	3	Coily, Green Ball, Ugg/Wrong Way, Slick/Sam	2250
	3	2	Red Balls, Coily, Green Ball, Slick/Sam	2500
	4	2	Red Balls, Coily, Green Ball, Ugg/Wrong Way, Slick/Sam	2750
LEVEL III	1	4	Red Balls, Coily, Green Ball, Slick/Sam	3000
	2	4	Coily, Green Ball, Ugg/Wrong Way, Slick/Sam	3250
	3	3	Red Balls, Coily, Green Ball, Ugg/Wrong Way, Slick/Sam	3500
	4	3	Red Balls, Coily, Green Ball, Ugg/Wrong Way, Slick/Sam	3750
LEVEL IV	1	6	Red Balls, Coily, Green Ball, Slick/Sam	4000
	2	6	Red Balls, Coily, Green Ball, Ugg/Wrong Way, Slick/Sam	4250
	3	5	Red Balls, Coily, Green Ball, Slick/Sam	4500
	4	4	Red Balls, Coily, Green Ball, Ugg/Wrong Way, Slick/Sam	4750
LEVEL V	1	7	In Level V all characters will appear in each Round	4750
	2	6		5000
	3	6		5000
	4	5		5000
LEVEL VI THRU LEVEL IX	1	5	All characters will appear in each Round in Level VI thru Level IX	5000
	2	5		5000
	3	5		5000
	4	5		5000

SCORING

- Luring "Coily" off the edge
Scores 500 points and clears pyramid of characters
- Hopping onto "Slick" or "Sam"
Scores 300 points
- Hopping onto Green Ball
Scores 100 points and freezes characters but not "Q*Bert"
- Changing cubes to designated color
Scores 25 points
- Changing cubes to intermediate color (in Level II or Up)
Scores 15 points
- Unused disks
Scores 50 points
- Round Completion Bonus
See Round Progression Chart

WHO'S WHO and WHAT'S WHAT

Q*Bert

300 Slick

300 Sam

100

25

Hopping on takes Q*Bert back to the top

DEADLY TO TOUCH!

500 Coily





Ugg

Wrong-way

V. SOUND/SPEECH, VI. GAME ADJUSTMENTS / OPTIONS

V. SOUND/SPEECH

ATTRACT MODE

SPEECH

"HELLO, I'M TURNED ON"

OCCURENCE

When game is powered up.

GAME MODE

SPEECH

(Garbled Nonsense Speech)

"BYE, BYE"

OCCURENCE

When "Q*Bert" is killed.

When the characters "Slick/Sam" and "Ugg/Wrong Way" are present.

When player has finished entering his initials on high score table.

VI. GAME ADJUSTMENTS/OPTIONS

A. CONTROL BOARD SWITCH ADJUSTMENTS

SWITCH 1 _____ **DEMONSTRATION MODE***
ON INFINITE LIVES
OFF NORMAL PLAY

SWITCH 2 _____ **ATTRACT PLAY**
ON NO SOUND
OFF SOUND

SWITCH 3 _____ **NORMAL/FREE**
ON FREE PLAY
OFF NORMAL GAME

SWITCH 4 _____ **GAME MODE**
ON COCKTAIL
OFF UPRIGHT

SWITCH 5 _____ **NOT USED**

SWITCH 6 _____ **KICKER**
ON KICKER ON
OFF KICKER OFF

SWITCH 7 _____ **NOT USED**

SWITCH 8 _____ **NOT USED**

*IN DEMONSTRATION MODE THE PLAYER WILL HAVE INFINITE LIVES AND CAN PROGRESS THROUGH THE ROUNDS BY HITTING EITHER START BUTTON.

B. SOUND ADJUSTMENTS

The audio output is controlled by the potentiometer mounted on the service panel assembly (located inside the coin mechanism door).

Turning the potentiometer counter-clockwise will decrease the volume. Turning it clockwise will increase the volume.

IMPORTANT: Each of the potentiometers installed on the Sound/Speech board have been factory adjusted. The potentiometer settings should never be changed when performing the recommended calibration procedure.

C. MONITOR ADJUSTMENTS

Normally, few if any adjustments are required for proper monitor operation. However, after any major repairs to the monitor chassis refer to the attached monitor manual.

VII. BOOKKEEPING AND SELF TEST

BOOKKEEPING

The battery back-up bookkeeping functions of Q*Bert (GV-103) are contained in Self Test steps 3 and 4. These are in addition to the electro-mechanical coin counter located inside the front door panel. Every time a coin is inserted into a coin slot, the counter is energized, incrementing the count.

SELF TEST

The self-test consists of six functions which may be used to identify problems in the video system and to change program parameters.

The self-test mode is entered by setting the self-test toggle switch located inside the cash door to "TEST". A selection of available tests is displayed on the monitor. To return to the GAME mode at any time, the operator needs only to set the toggle switch back to "GAME".

Selection of tests is done with the push button switch labeled "SELECT". Upon entering the test mode, a flashing arrow points to the first test selection. Momentarily depressing the "SELECT" button will advance through each selection one by one.

When the arrow is pointing to the desired test, the operator may begin that test by pressing the "SELECT" button and holding it down until the test appears on the screen.

Once a test has been selected, the operator can return to the selection list by holding down the select switch until it re-appears. The eight tests are as follows:

1. MONITOR ADJUSTMENT

Four patterns can be displayed on the screen for adjusting monitor color, brightness, contrast and convergence. The patterns are: Color bars, a cross-hatch, a gray scale, and a dot pattern. By momentarily pressing the select switch, the operator may cycle through the four patterns.

2. DIP SWITCHES

A functional description of the eight Dip Switches located on the Logic Board Assy. is displayed. Changing any switch will cause an immediate update of the description displayed on the screen.

3. DISTRIBUTIONS

Selecting this test will first display a distribution option. The distributions can be reset to zero by pressing either start button, and then pressing the SELECT button momentarily. Following the latter, a cleared distribution screen will be displayed; or the distribution screen can be viewed without clearing it by pressing the SELECT button momentarily when in this test mode. The distribution screen will show three categories of counts — 1) Level/Round; 2) Time; 3) Score. These categories, used with the coin meter count, can be used to derive the game percentages and averages.

The categories are presented in three vertical pairs of columns displaying the level of category and the number of players to attain that level. The left category is a list of the Levels and Rounds up to Level 3, Round 4. Next to each Level/Round is the number of players to reach that Level/Round. The middle two columns are a list of game durations in 45 second increments and the number of players to last that long next to it. The right two columns are a category of players scores in increments of 3000 points and the number of players to attain that score level.

At the bottom of each category will be displayed the number of players to go beyond the defined levels. The number of players in each category level are independent of the other categories, so each player will be listed once each for Level, Time and Score. The number of players in each category level are given in 4 digit values only, so the distribution table should be reset every two weeks or so to insure that meaningful information will be contained in it.

4. OPTIONS/PARAMETERS

This test will allow the operator to view and change all game options on one screen. During this test the screen will display seven operator adjustable options. Pressing the "SELECT" button momentarily will advance the arrow to the next option desired. When the arrow is pointing to the appropriate option, the

VII. BOOKKEEPING AND SELF TEST

operator can then adjust that option by pressing either of the control panel start buttons, to select the desired value for each option.

- A. Reset High Score Table — Pressing either start button will reset all 23 high scores to random values and initials starting at 3000 points for No. 1.
- B. Factory Preset — Using this option will reset all the following options to the factory recommended levels: 1 Coin/1 Credit, 3 Lives, Normal Difficulty, 1st Extra Life at 8000 Points, Each additional life at each subsequent 14000 Points.
- C. Coin/Credit Combinations — Pressing either Start button will cycle thru three coin combinations:
 - 1) 1 coin = 1 play
 - 2) 1 coin = 2 play
 - 3) 2 coin = 1 play
- D. Lives Per Game — Pressing either Start button will cycle thru three choices; 3 Lives Per Game, 4 Lives Per Game, 5 Lives Per Game.
- E. Difficulty — Two choices may be selected with either Start button; Normal or Hard.
- F. 1st Extra Life — There are six choices, from 6000 Points to 11000 Points, that will be displayed by pressing either Start button. Any value can be chosen to award the first extra life by stopping on that choice and then selecting the next option.
- G. Each Additional Life — There are six choices, from 12000 Points to 17000 Points, that will cycle thru by pressing either Start button. Any value can be selected to award additional lives at each subsequent Point level chosen.

5. MEMORY

For each RAM memory chip; a green check (✓) or red (x) appears signaling that the chip is good or bad respectively.

For each ROM memory chip, a check sum is displayed. If you have a suspect ROM, refer to your distributor for the correct check sum number.

6. SWITCHES

A colored square is displayed for each player button. Pressing a button causes the appropriate square to change color. For each coin mechanism, a digit is displayed (initially 0). Inserting a coin into a coin chute will increment the appropriate value without affecting the coin meter.

7. SOUND TEST

After selecting this test a count will appear on the screen representing the various sounds that are produced by the Q*Bert game. There will be 36 different sounds produced and the screen count will stop at 41. Pressing either Start button will suppress all sound output and speed up the count so a particular sound can be sought out and checked.

Note: The count on the screen represents the binary signal code that will be sent to the A6 Sound/Speech board through the six sound input lines on the A6J1 connector. When executing the Sound Test sequence, there will be no sounds produced on counts 16, 29, 30, 31 and 32. There are no sounds assigned to these numbers.

8. OBJECT PRIORITY

Visual inspection must be used to determine the priority of two or more objects occupying the same area of the screen; that is, which objects appear to be in front of others and which are behind.

A total of 62 identical objects are placed on the screen in 4 rows. Each object overlaps another such that the first object appears to be in front, and succeeding objects appear to be placed behind all previous ones. When this display is completed, the procedure is repeated such that each new object appears to be in front of all the previous ones.

VIII. GENERAL INFORMATION

A. PRINTED CIRCUIT BOARDS ARE DESIGNATED AS FOLLOWS:

- A1 Logic Board Assy.
- A3 Power Supply Assy.
- A6 Sound/Speech Assy.
- A8 Filter Board

B. WIRE COLORS ARE SHOWN AS NUMBERS:

0 Black	5 Green
1 Brown	6 Blue
2 Red	7 Purple
3 Orange	8 Slate
4 Yellow	9 White

For example, 688 is a BLUE- SLATE-SLATE striped wire.

C. FUSES

BOTTOM PANEL

F1	Primary Power		4 Amp SLO-BLO
F2	6.3 VAC		3 Amp SLO-BLO
F3	Monitor		2 Amp SLO-BLO
F4	9 VAC		10 Amp SLO-BLO
F5	15 VAC		1 Amp SLO-BLO
F6	Knocker	+30VDC	1 Amp SLO-BLO

POWER SUPPLY ASSY. (A3)

F11	+5VDC Source		5 Amp SLO-BLO
F21	Sound/Speech Assy.	+30VDC	1½ Amp SLO-BLO
F31	Sound/Speech Assy.	+12VDC	¼ Amp SLO-BLO
F32	Sound/Speech Assy.	-12VDC	¼ Amp SLO-BLO
F41	Coin Meter	+20VDC	1 Amp SLO-BLO

VIII. GENERAL INFORMATION

POWER SUPPLY SPECIFICATIONS

LOCATION	VOLTAGE	PROTECTION
Logic Board Assy.	+5VDC	Voltage adjustable. 6Amps over-voltage protection and fused for over-current protection.
Sound/Speech Board	+30VDC	1.5Amps fused for over-current protection. The reference for this circuit is a 1N5363 + 30VDC Zener controlling the base of an emitter follower pass transistor.
Sound/Speech Board	+12VDC -12VDC	100 milliamps fused for over-current protection. The plus and minus 12 volts supplies are the 7812 and 7912 IC regulators respectively.
Coin Meter	+20VDC	Full wave rectified unfiltered voltage, fused for over-current protection.
Coin Chute Lights	+4.5VDC	Full wave rectified unfiltered voltage, fused for over-current protection.
Monitor and Marquee	100VAC or 115VAC, 60HZ	Isolated, fused AC voltage.

IX. THEORY OF OPERATION

INTRODUCTION

The character based graphics system designated GG-III has two main subdivisions. The first subdivision is the Central Processor Unit (CPU) which has three partitions:

- a. Microprocessors
- b. Memory
- c. Input and Output ports (I/O)

The Intel 8088 microprocessor is used and 32K bytes of memory is reserved for programming space and has 5 input ports and 5 output ports. The second subdivision is the video state machine which generates and controls the video signal to the monitor. The state machine has three partitions:

- a. System Clock (CLK)
- b. Foreground generator (FGND)
- c. Background generator (BGND)

The system clock is driven by a 20MHZ crystal, divided down for a 5MHZ dot clock.

All inputs and outputs including the video control and general purpose I/O are memory-mapped, (i.e. everything within the system can be addressed in a single segment of 64K addresses as memory).

The video control unit is divided into an "object-oriented" foreground driver and "character-oriented" background driver. The screen resolution is 256 pixels horizontally, and 240 lines vertically for both foreground and background. The CPU communicates with the foreground driver and background driver by writing data into the

designated memory areas in a certain format. The foreground is designed to display moving objects on the screen with a minimum overhead to the processor. The game programs will only have to specify the vertical and horizontal position and the object select number to the foreground driver. The background video supplements the foreground with relatively static figures on the screen. The CPU specifies all the character positions on the screen with desired "character" patterns.

A 5MHZ system clock drives a 9 bit horizontal dot counter and an 8 bit vertical line counter. The horizontal counter counts from 0 to 255 during active scan line and 256 to 317 during horizontal blanking time. When the horizontal counter reaches 317, the horizontal counter resets to 0. At the beginning of the horizontal blanking time (horizontal counter = 256) it increments the vertical counter. The vertical counter counts from 0 to 239 during active vertical scan time and 240 to 255 during vertical blanking time.

The battery backup system supports two battery RAM's that store all of the bookkeeping functions. The battery is maintained at a +3.6V reference by a trickle charge supplied on the logic board regulated by a current limiting resistor. If the AC power to the game is interrupted, the battery allows the RAM's to store the data contained in the Distributors table and the Options/Parameters screen.

X. WIRING AND SCHEMATIC DIAGRAMS, PARTS LISTS

TABLE OF CONTENTS

	PAGE
LOGIC BOARD ASSY. (A1)	
COMPONENT LOCATION AND PARTS LIST	13
SCHEMATIC DIAGRAM (SHEET 1 OF 3)	16
SCHEMATIC DIAGRAM (SHEET 2 OF 3)	18
SCHEMATIC DIAGRAM (SHEET 3 OF 3)	21
POWER SUPPLY ASSY. (A3)	
COMPONENT LOCATION AND PARTS LIST	24
SCHEMATIC DIAGRAM	25
SOUND/SPEECH ASSY. (A6)	
COMPONENT LOCATION AND PARTS LIST	27
SCHEMATIC DIAGRAM	28
PRIMARY POWER/FILTER BOARD/ INTERCONNECTION DIAGRAM	30

**LOGIC BOARD ASSY. (A1),
PARTS LIST**

**MISCELLANEOUS ELECTRONIC
COMPONENTS**

REFERENCE	DESCRIPTION	PART NO.
Bat 1	Battery, 3.6V	XO-458
C1-C16	Capacitor, 0.1 UF 50V AX. CR. +80%-20%	XO-230
C25	Capacitor, 100 UF, 25V EL-AX	XO-212
C26	Capacitor, 0.1 UF, 50V AX. CR. +80%-20%	XO-230
C27	Capacitor, 100 UF, 25V EL-AX	XO-212
C31-34	Capacitor, 0.1 UF, 50V AX. CR. +80%-20%	XO-230
C51	Capacitor, 100 PF, 100V CMD 5%	XO-198
C52	Capacitor, 0.1 UF, 100V CMD 5%	XO-196
ALL UNMARKED CAPACITORS	.01 UF, 50V AX. CR. +80%-20%	XO-229
D2	Diode, 1N4454	XO-275
D4	Diode, 1N4733A	XO-274
D81	Diode, 1N4148	XO-261
O1-O4	Transistor, 2N6044	XO-120
O81-O87	Transistor, MPSA70	XO-309
R1-R16	Resistor, 470 OHM, 5% 1/4W	XO-35
R37, R38	Resistor, 330 OHM, 5% 1/4W	XO-34
R39	Resistor, 130 OHM, 5% 1/4W	XO-172
R40	Resistor, 270 OHM, 5% 1/4W	XO-68
R41, R42	Resistor, 510 OHM, 5% 1/4W	XO-25
R43	Resistor, 130 OHM, 5% 1/4W	XO-172
R44, R45	Resistor, 1K OHM, 5% 1/4W	XO-5
R51, R52	Resistor, 330 OHM, 5% 1/4W	XO-34
R53, R54, R56	Resistor, 1K OHM, 5% 1/4W	XO-5
R57, R58	Resistor, 560 OHM, 5% 1/4W	XO-36
R59-R61	Resistor, 1K OHM, 5% 1/4W	XO-5
R63, R64	Resistor, 1K OHM, 5% 1/4W	XO-5
R70	Resistor, 1K OHM, 5% 1/4W	XO-5
R73, R74	Resistor, 1K OHM, 5% 1/4W	XO-5
R76-R80	Resistor, 1K OHM, 5% 1/4W	XO-5
R81	Resistor, 820 OHM, 5% 1/4W	XO-174
R82	Resistor, 100 OHM, 5% 1/4W	XO-28
R83, R84	Resistor, 15 OHM, 5% 1/4W	XO-171
R85	Resistor, 180 OHM, 5% 1/4W	XO-24
R86, R87	Resistor, 15 OHM, 5% 1/4W	XO-171
R88	Resistor, 180 OHM, 5% 1/4W	XO-24
R89, R90	Resistor, 15 OHM, 5% 1/4W	XO-171
R91	Resistor, 180 OHM, 5% 1/4W	XO-24
R92	Resistor, 1K OHM, 5% 1/4W	XO-5
R93	Resistor, 2K OHM, 5% 1/4W	XO-14
R94	Resistor, 1K OHM, 5% 1/4W	XO-5
R95	Resistor, 470 OHM, 5% 1/4W	XO-35
R96	Resistor, 240 OHM, 5% 1/4W	XO-173
R97	Resistor, 2K OHM, 5% 1/4W	XO-14
R98	Resistor, 1K OHM, 5% 1/4W	XO-5
R99	Resistor, 470 OHM, 5% 1/4W	XO-35
R100	Resistor, 240 OHM, 5% 1/4W	XO-173
R101	Resistor, 2K OHM, 5% 1/4W	XO-14
R102	Resistor, 1K OHM, 5% 1/4W	XO-5
R103	Resistor, 470 OHM, 5% 1/4W	XO-35
R104	Resistor, 240 OHM, 5% 1/4W	XO-173
SIP 1, SIP 2, SIP 4	Resistor, Dip, 4 7K, 9 Pin	XO-492
SIP 71, SIP 72,	Resistor, Dip, 1K, 9 Pin	XO-493
SIP 73		
X-TAL 1	Crystal, 15 MHZ	XO-482
XTAL 51	Crystal, 20 MHZ	XO-494
	Dip Switch	XO-505
	20 Pin Dip Socket	XO-491
	22 Pin Dip Socket	XO-467
	24 Pin Dip Socket	XO-529
	28 Pin Dip Socket	XO-536
	40 Pin Dip Socket	XO-530

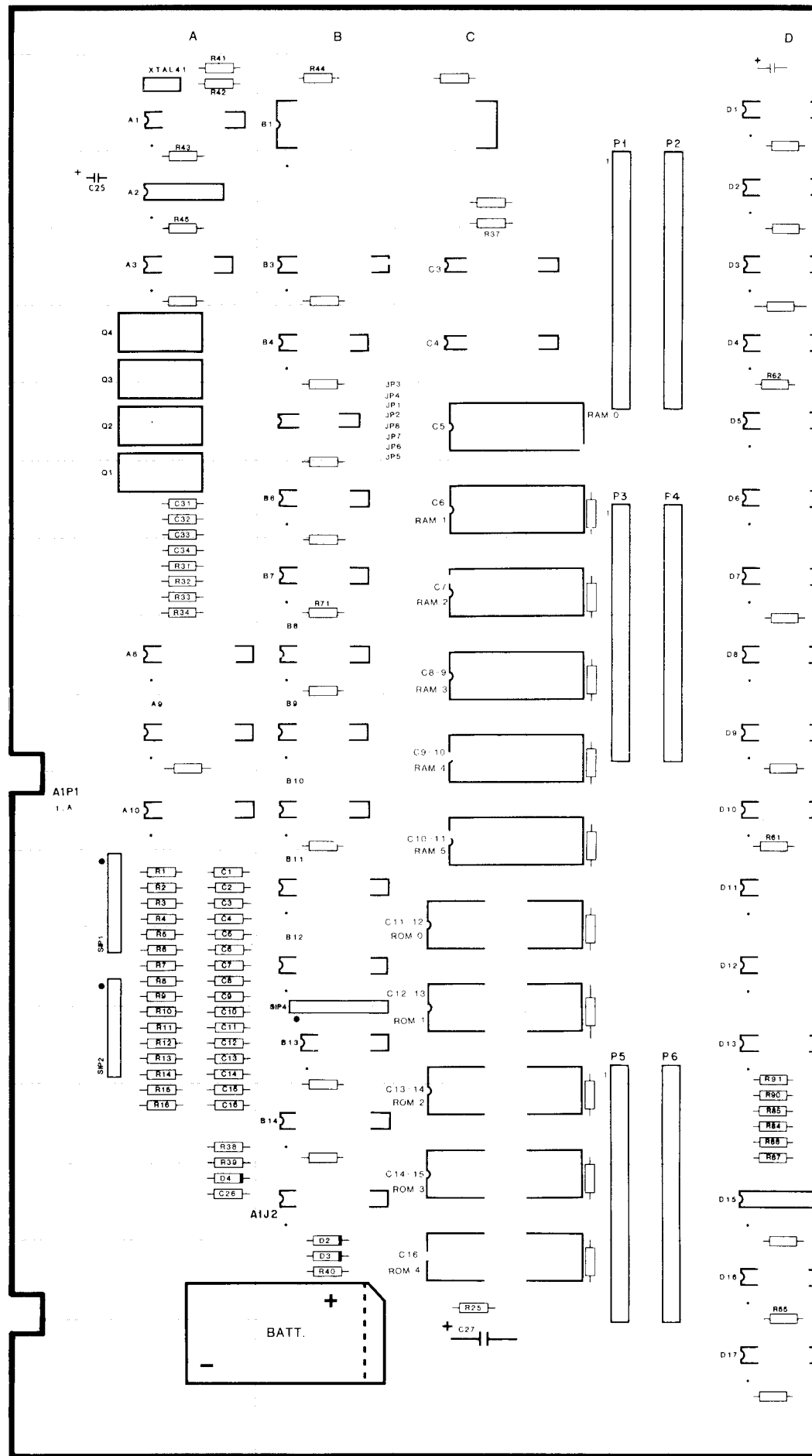

AUTOMATIC DIAGRAMS, PARTS LISTS

BOARD ASSY. (A1), COMPONENT LOCATION

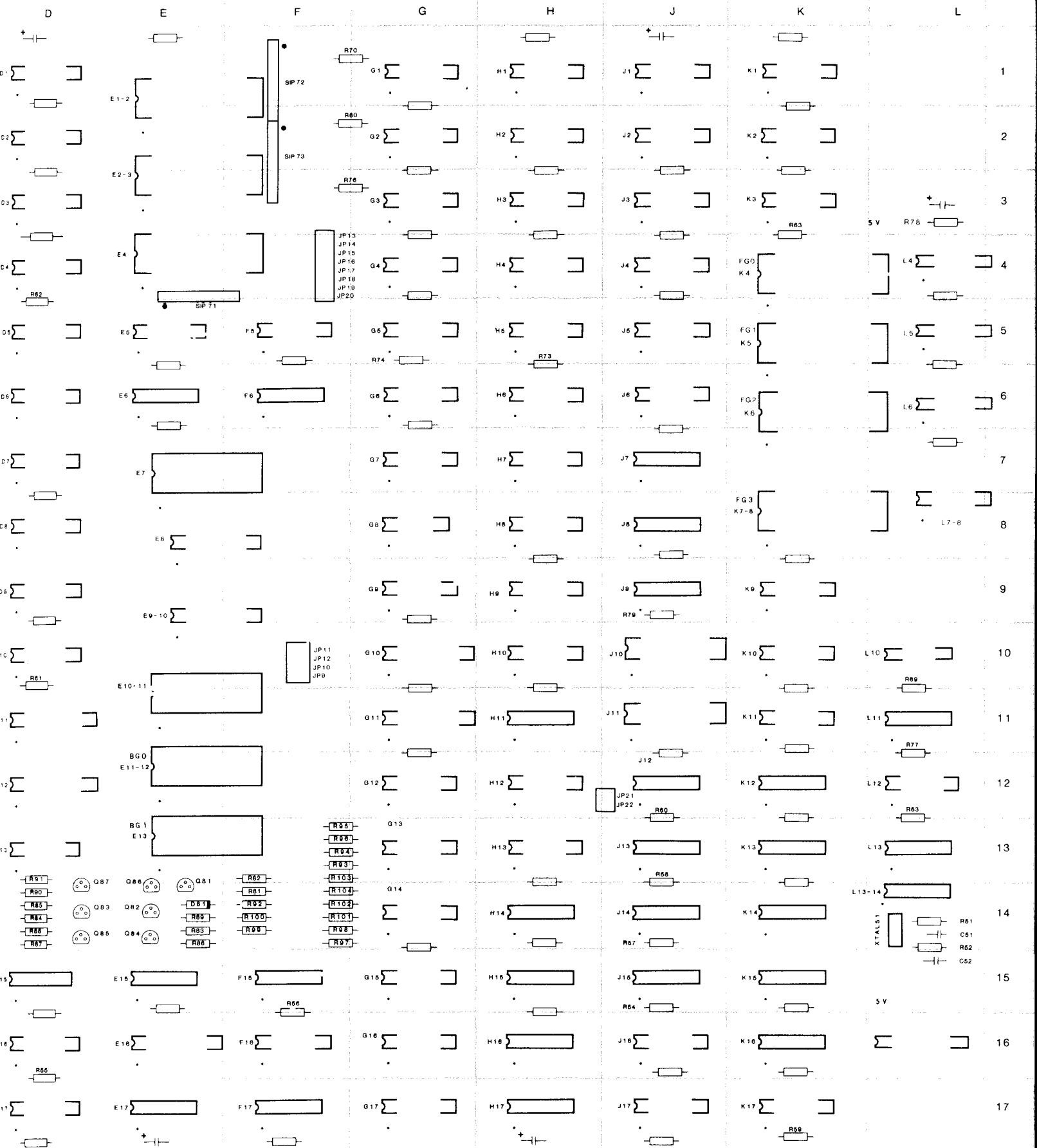

LOGIC BOARD ASSY. (A1), PARTS LIST (CONT.)

INTEGRATED CIRCUITS

REFERENCE	DESCRIPTION	PART NO.	REFERENCE	DESCRIPTION	PART NO.
A1	Logic Board Assy.	MA-378	G7	74LS157 Quad 2-input multiplexer	XO-114
A2	8284 CLK Driver	XO-478	G8	74LS74 Dual D-type flip flop	XO-434
A3	74LS02 Quad 2-input "NOR" gate	XO-428	G9	74LS157 Quad 2-input multiplexer	XO-124
A8, A9, A10	74161 Synchronous 4-bit counter	XO-192	G10	74LS245 Octal bus transceiver	XO-79
B1	74LS377 Octal "D" Flip Flop	XO-97	G11	74LS374 Octal D-type flip flop	XO-96
B3	8088 CPU	XO-490	G12	74LS157 Quad 2-input multiplexer	XO-390
B4	74LS373 Octal D-type flip flop	XO-445	G13, G14, G15	7489 64-bit RAM	XO-88
B5	74LS367 Hex 3-state buffer	XO-444	G16, G17	74LS174 Hex D flip flop	XO-442
B6	74LS08 Quad 2-input "AND" gate	XO-86	H1, H2, H3, H4	74LS189 64-bit RAM	XO-89
B7	74HC138 Decoder/demultiplexer	XO-190	H5, H6,	74LS161 Synchronous presettable binary counter	XO-488
B8, B9, B10	74LS139 Dual 1 of 4 decoder	XO-419	H7, H8, H9, H10	74LS157 Quad 2-input multiplexer	XO-390
B11, B12, B14	74LS138 1 of 8 decoder	XO-437	H11	74LS260 Dual 5-input "NOR" gate	XO-93
C3	74LS240 Octal Buffer/line driver	XO-91	H12	74LS298 Quad 2-port register	XO-118
C4	74LS373 Octal D-type flip flop	XO-445	H13	74LS157 Quad 2-input multiplexer	XO-390
C5	74LS245 Octal Bus transceiver	XO-79	H14	74LS00 Quad 2-input "NAND" gate	XO-427
C6	RAM 1 6116LP-4	XO-191	H15	74LS30 8 input "NAND" gate	XO-432
C7	RAM 2 2128-2	XO-195	H16, H17	74LS86 Dual 2-input exclusive "OR" gate	XO-435
C8-9	RAM 3 2128-2	XO-195	J1, J2, J3,	74LS189 64-bit RAM	XO-89
C11-12	ROM 1 2764 8K x 8 EPROM	XO-489	J4, J5, J6	74LS04 Hex inverter	XO-418
C12-13	ROM 2 2764 8K x 8 EPROM	XO-489	J7	74LS32 Quad 2-input "OR" gate	XO-433
C13-14	ROM 2 2764 8K x 8 EPROM	XO-489	J8	7408 Quad 2-input "AND" gate	XO-404
D1	74LS139 Dual 1 of 4 Decoder	XO-419	J9	93422 256 x 2 bipolar RAM	XO-100
D2, D3, D4, D5, D6, D7, D8, D9, D10	74157 Quad 2-input multiplexer	XO-114	J10, J11	74LS02 Quad 2-input "NOR" gate	XO-428
D11	74LS374 Octal D-type flip flop	XO-96	J12	74LS74 Dual D-type flip flop	XO-434
D12	74LS244 Octal buffer/line driver	XO-117	J13	7407 Hex buffer/driver	XO-384
D13	74LS157 Quad 2-input multiplexer	XO-390	J14	74LS30 8 input "NAND" gate	XO-432
D15	74LS86 Quad 2-input exclusive "OR" gate	XO-435	J15	74LS161 Synchronous presettable binary counter	XO-488
D16	74LS283 4-bit binary full adder	XO-95	J16, J17	74LS379 Quad D-type flip flop	XO-98
D17	74LS161 Synchronous presettable binary counter	XO-488	K1, K2, K3	FG0 2764-3 8K x 8 EPROM	XO-489
E1-2, E2-3, E4	93419 64 x 9 bipolar RAM	XO-99	K4	FG1 2764-3 8K x 8 EPROM	XO-489
E5	74LS283 4-bit binary full adder	XO-95	K5	FG2 2764-3 8K x 8 EPROM	XO-489
E6	74LS30 8-input "NAND" gate	XO-432	K6	FG3 2764-3 8K x 8 EPROM	XO-489
E7	4801 1K x 8 RAM	XO-193	K7-8	74LS157 Quad 2-input multiplexer	XO-390
E8, E9-10	74LS245 Octal Bus Transceiver	XO-79	K9, K10, K11	74LS260 Dual 5-input "NOR" gate	XO-93
E10-11	4801 1K x 8 RAM	XO-193	K12	74LS32 Quad 2-input "OR" gate	XO-433
E11-12	2732A (BGJ) 4K x 8 EPROM	XO-485	K13	74LS08 Quad 2-input "AND" gate	XO-86
E13	2732A (BGI) 4K x 8 EPROM	XO-485	K14	74LS04 Hex inverter	XO-400
E15	74LS86 Quad 2-input exclusive "OR" gate	XO-435	K15	74LS20 Dual 4-input "NAND" gate	XO-430
E16	74LS273 8-bit register	XO-94	K16	74LS161 Synchronous presettable binary counter	XO-488
E17	74LS20 Dual 4-input "NAND" gate	XO-430	K17	74LS166 8-bit shift register	XO-391
F5	74LS283 4-bit binary full adder	XO-95	L4, L5, L6, L7	74LS74 Dual flip flop	XO-434
F6	74LS32 Quad 2-input "OR" gate	XO-433	L10	74LS74 Dual flip flop	XO-434
F15	74LS04 Hex inverter	XO-418	L11	74LS20 Dual 4-input "NAND" gate	XO-430
F16	74LS161 Synchronous presettable binary counter	XO-488	L12	74LS161 Synchronous presettable binary counter	XO-440
F17	74LS86 Quad 2-input exclusive "OR" gate	XO-435	L13	74S74 Dual D-type pos. edge trig. flip flop (T. I. only)	XO-87
G1, G2, G3, G4, G5	74LS157 Quad 2-input multiplexer	XO-390	L13-14	74S04 Hex inverter	XO-400
G6	74LS161 Synchronous presettable binary counter	XO-440			

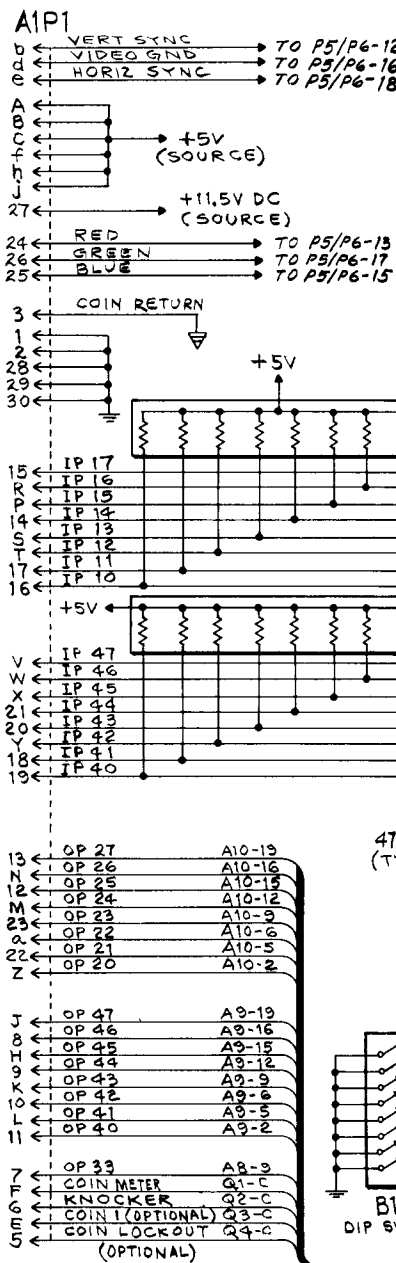
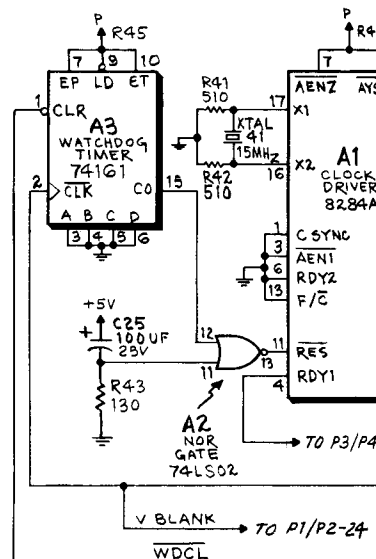

X. WIRING AND SCHEMATIC DIAGRAMS, PARTS LISTS

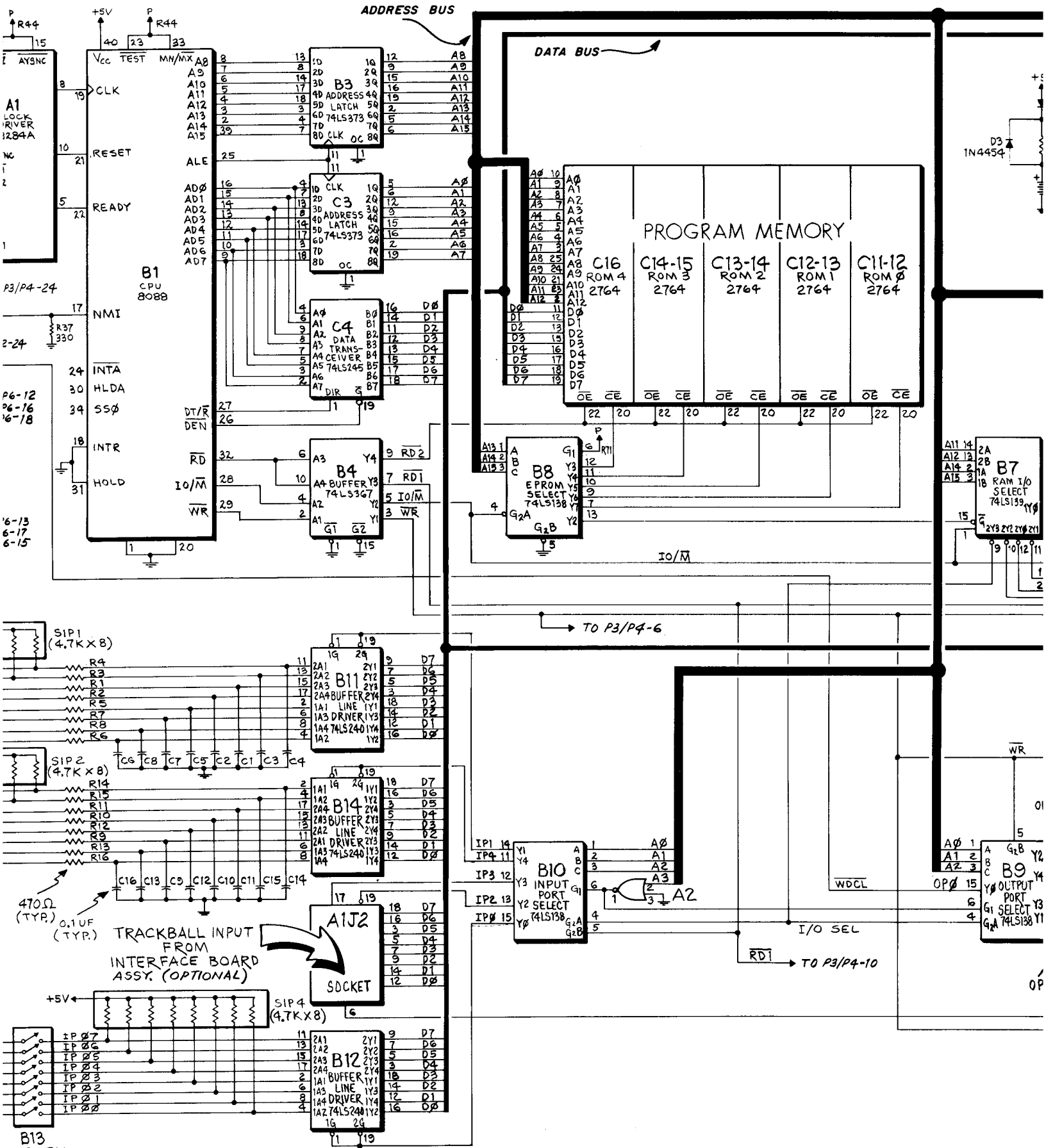

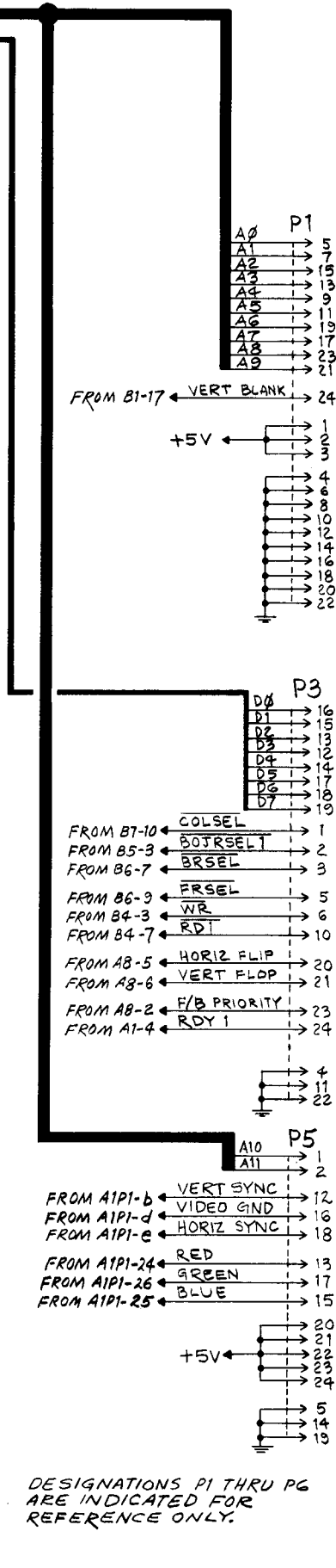
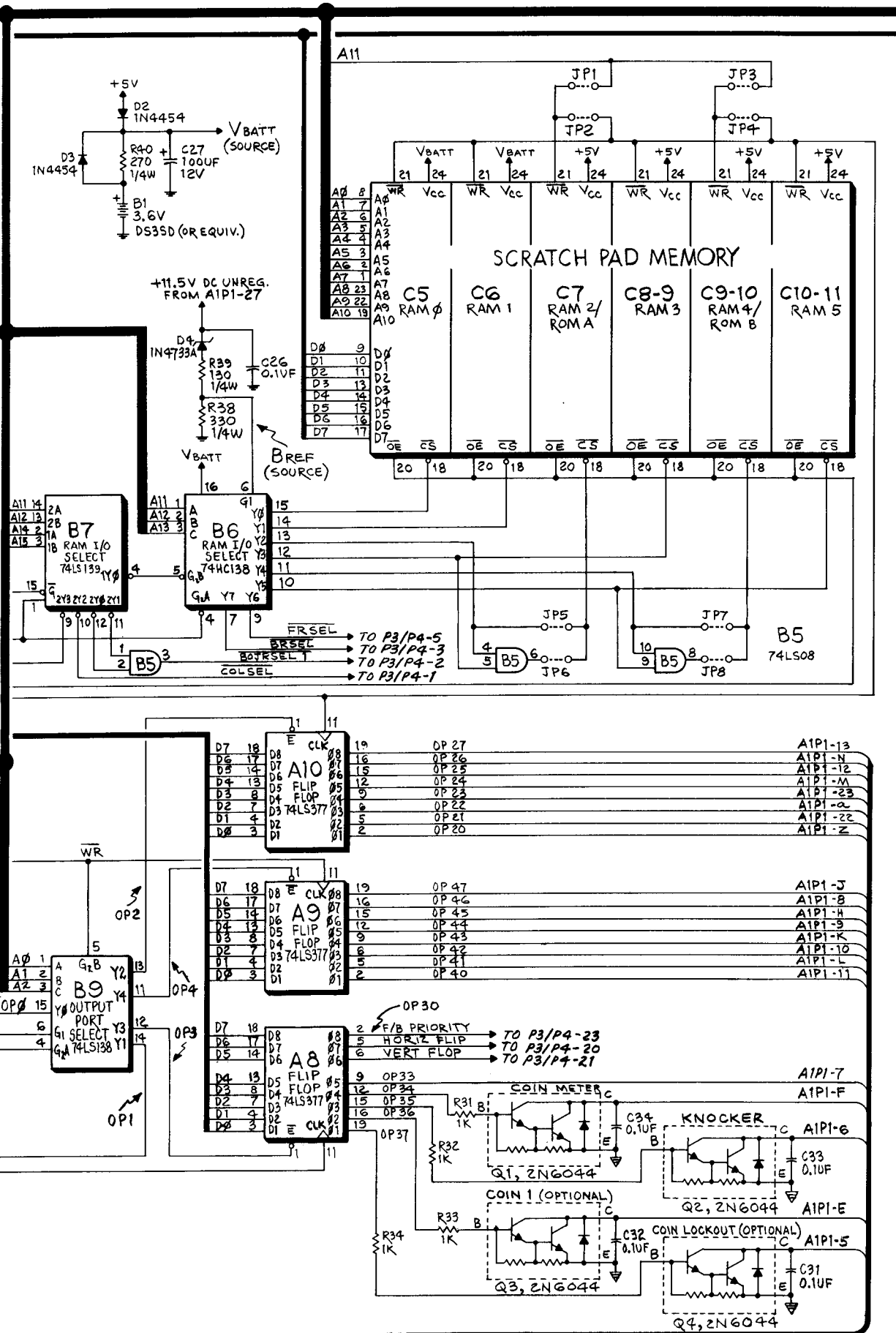

LOGIC BOARD ASSY. (A1), SCHEMATIC DIAGRAM, SHEET 1 OF 3

X. WIRING AND SCHEMATIC DIAGRAMS, PARTS LISTS

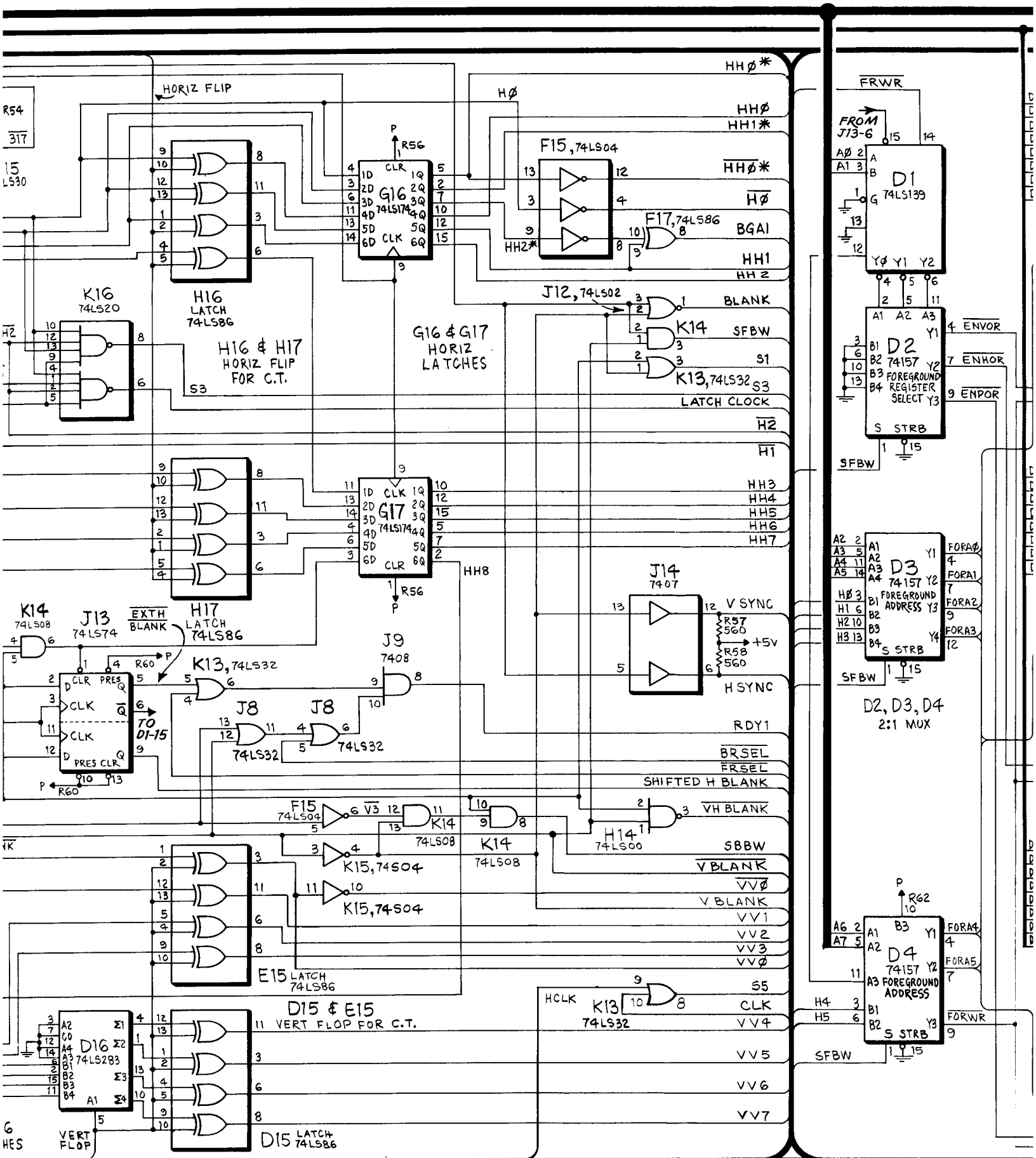

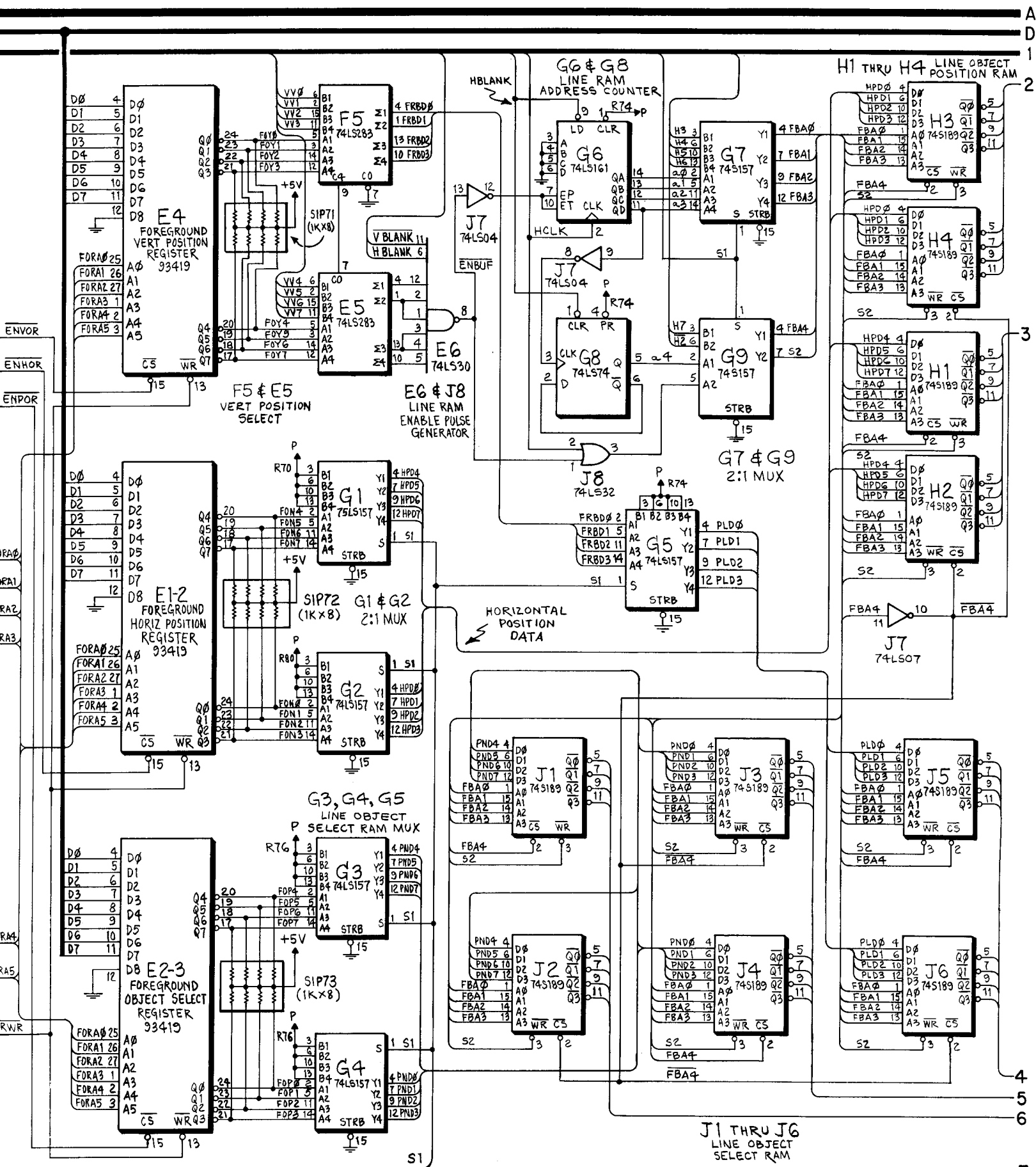

LOGIC BOARD ASSY. (A1), SCHEMATIC DIAGRAM, SHEET 2 OF 3

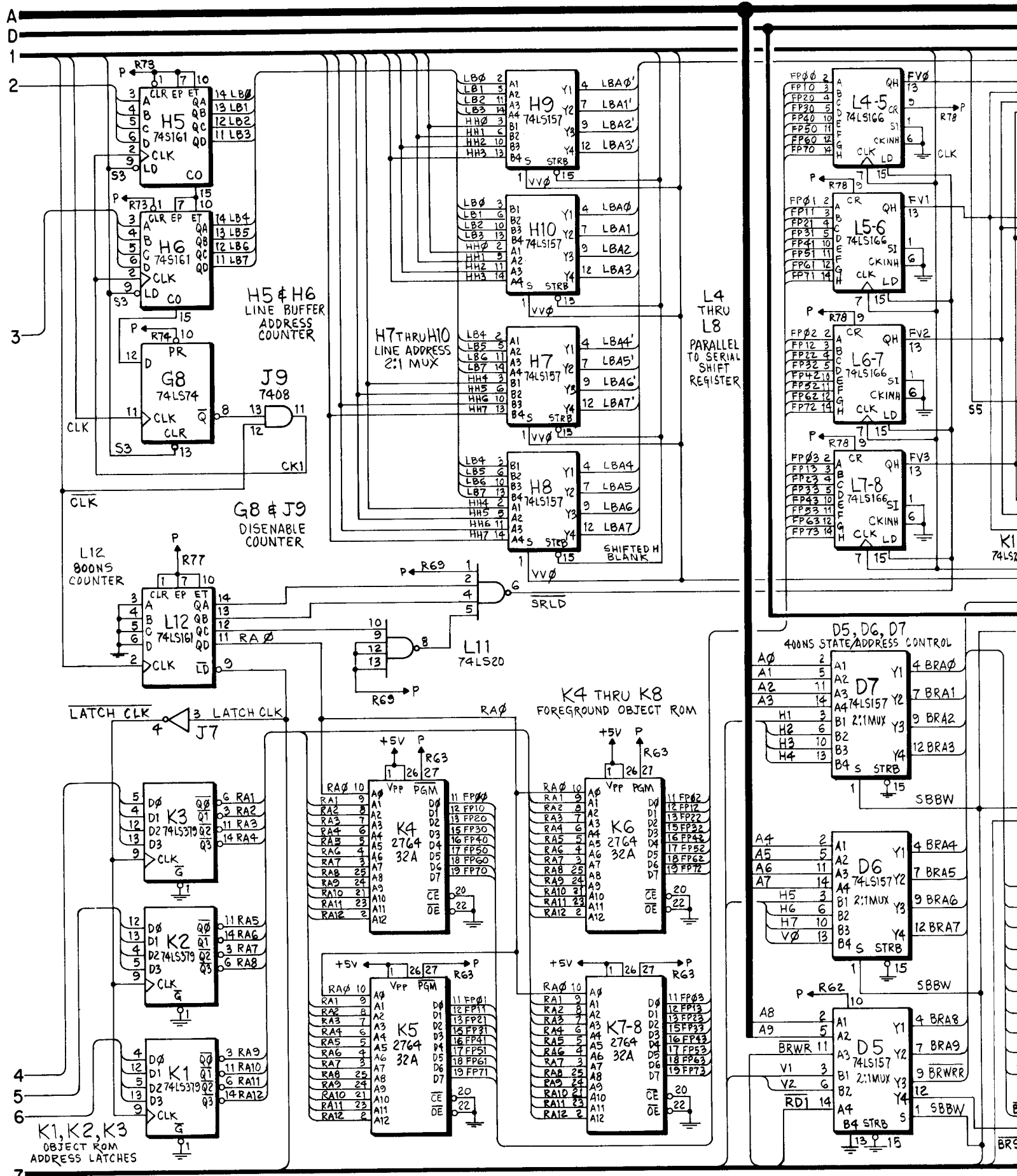

A
D
1
2
3
4
5
6
7

X. WIRING AND SCHEMATIC DIAGRAMS, PARTS LISTS

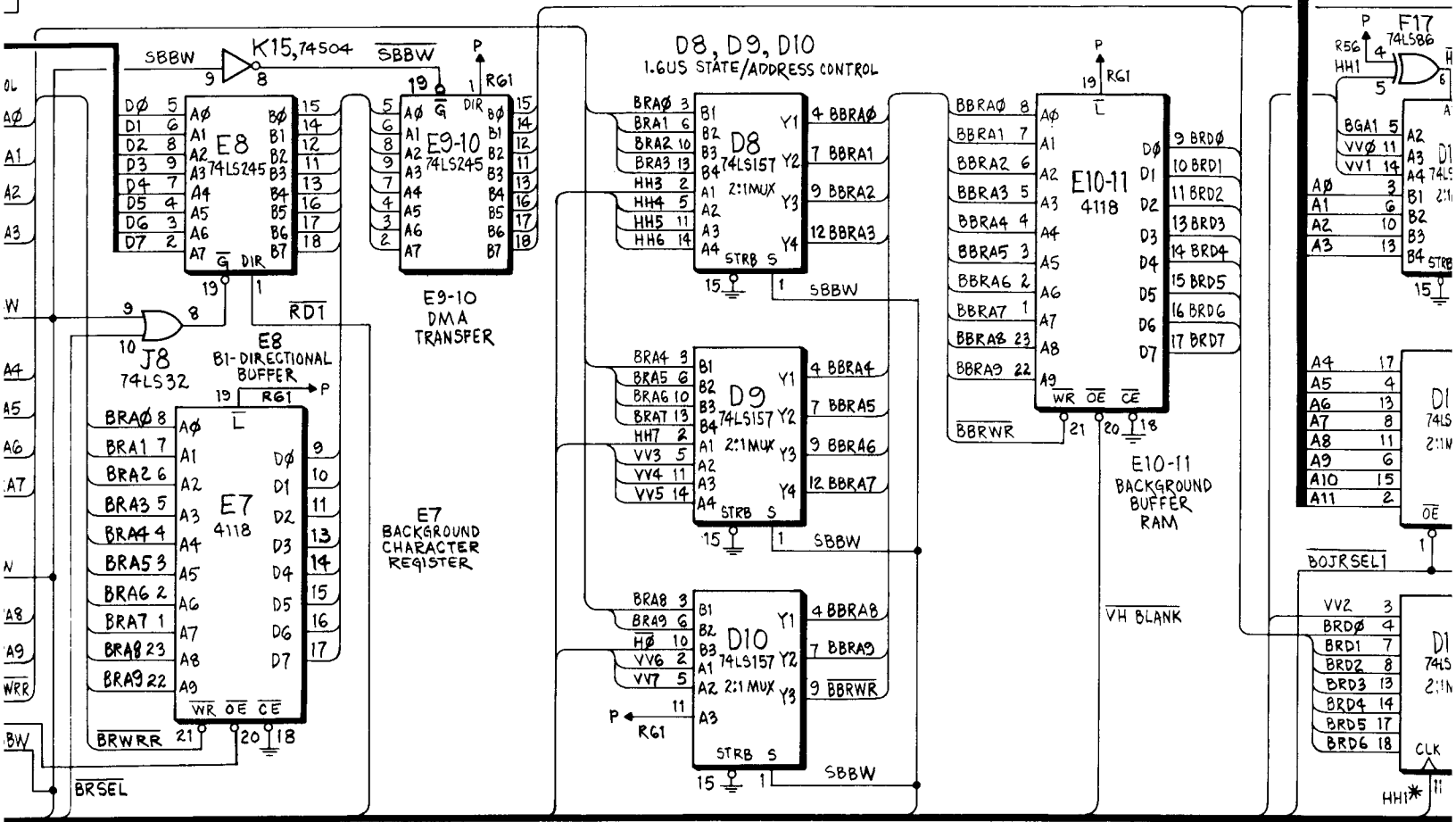
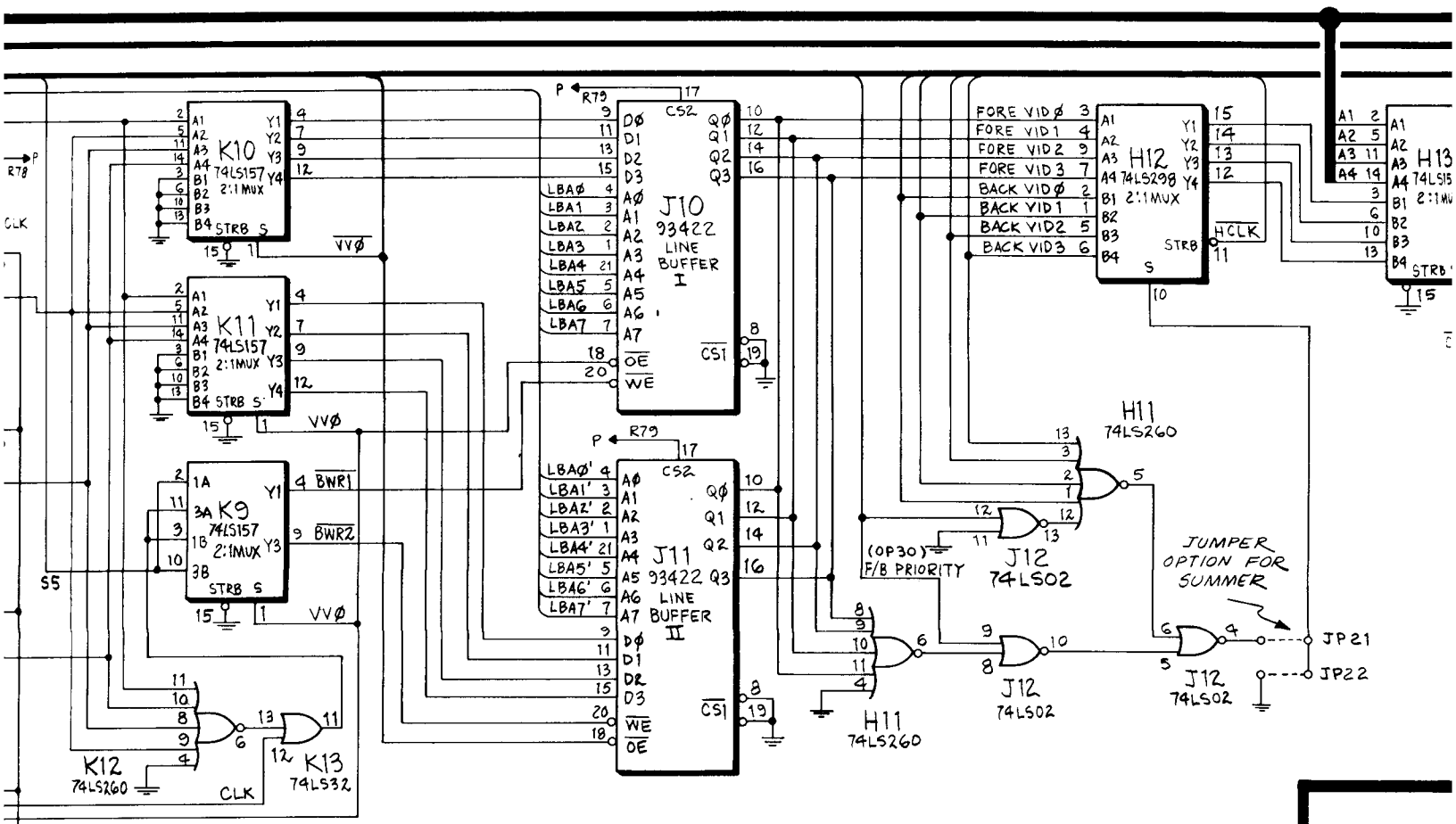

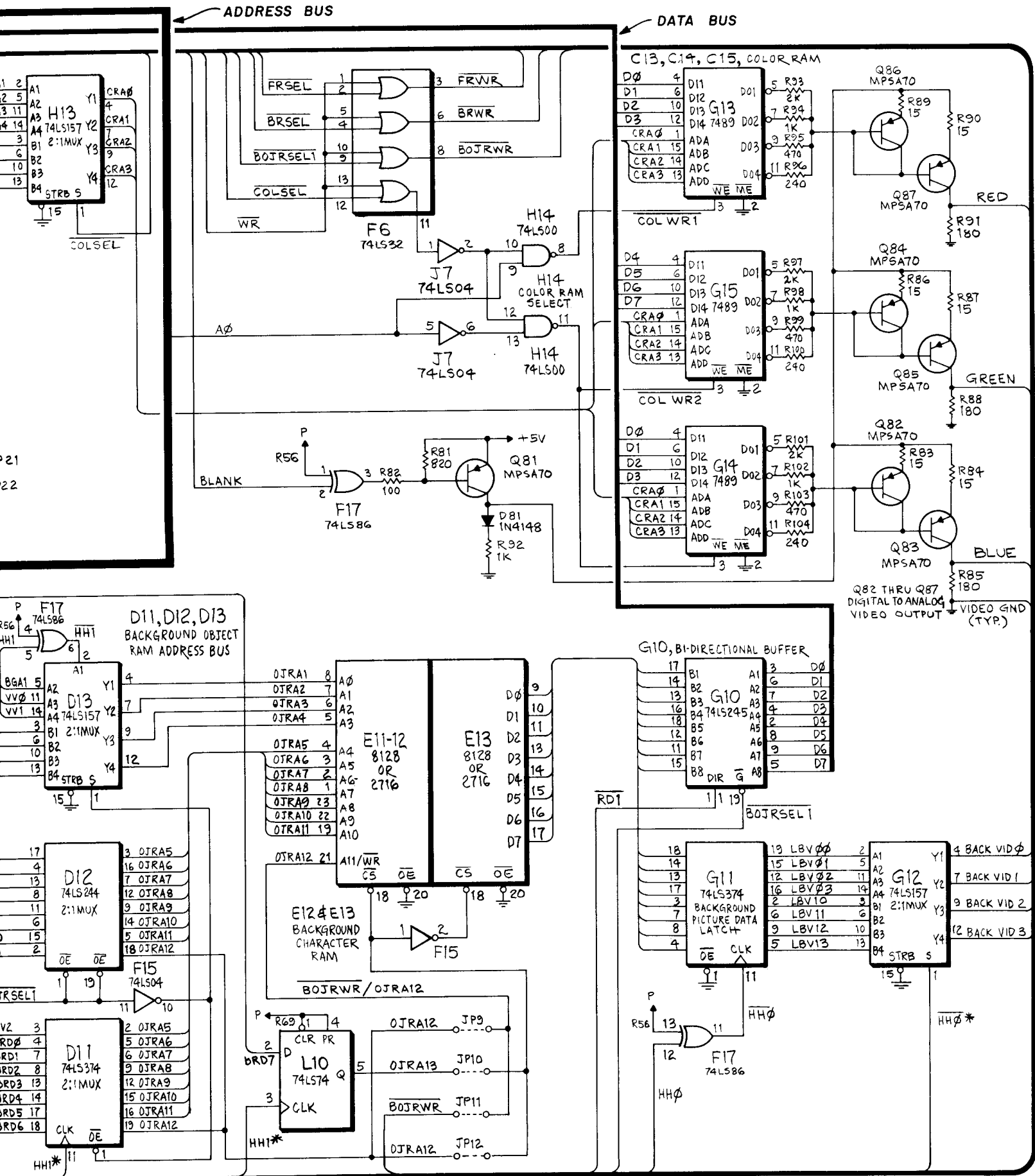

LOGIC BOARD ASSY. (A1), SCHEMATIC DIAGRAM, SHEET 3 OF 3

X. WIRING AND SCHEMATIC DIAGRAMS, PARTS LISTS

POWER SUPPLY ASSY. (A3), COMPONENT LOCATION

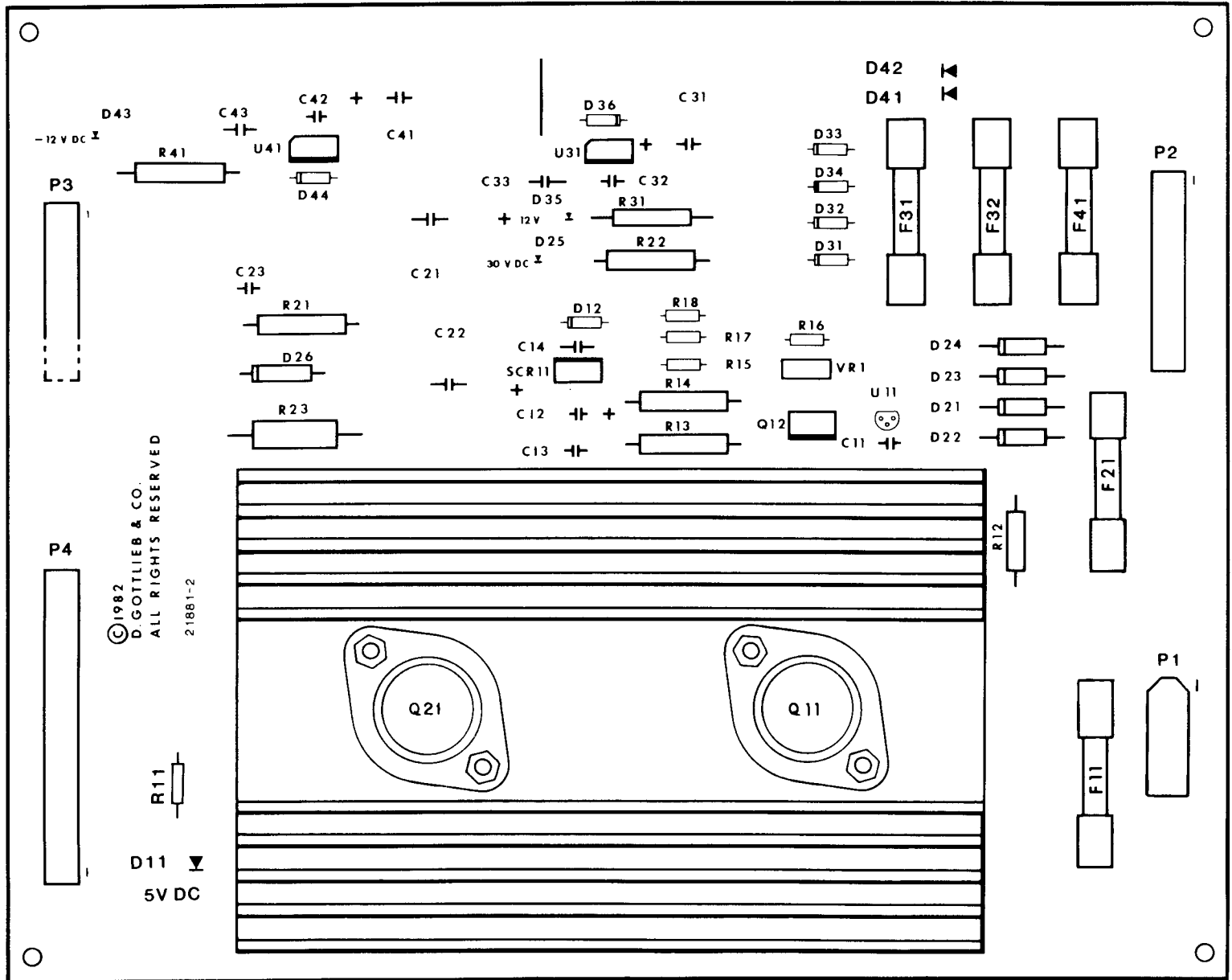

POWER SUPPLY ASSY. (A3), PARTS LIST

REFERENCE	DESCRIPTION	PART NO.	REFERENCE	DESCRIPTION	PART NO.
	Power Supply Assy.	MA-430	P2	Connector, 10 PIN	XO-531
C11, C32, C42	Capacitor, .01 mfd., 50V	XO-229	P3	Connector, 7 PIN	XO-526
C12	Capacitor, 100UF, 16V	XO-235	P4	Connector, 16 PIN	XO-372
C13, C23	Capacitor, 0.1UF, 100V	XO-234	Q11	Transistor, PNP, 2N5879	XO-323
C14, C33, C43	Capacitor, 0.2UF, 16V	XO-205	Q12	Transistor, NPN, TIP31B	XO-641
C21, C22	Capacitor, 2200UF, 75V	XO-132	Q21	Transistor, NPN, 2N3055	XO-301
C31, C41	Capacitor, 470UF, 35V	XO-284	R11	Resistor, 470 OHM, 5% 1/2W	XO-55
D11, D25	Diode, Light Emitting MV-5752	XO-270	R12	Resistor, 100 OHM, 5% 1W	XO-137
D35, D43	Diode, Zener, 5.6V, 5%, 1W, 1N4734A	XO-255	R13, R14	Resistor, 12 OHM, 5% 2W	XO-138
D12	Diode, Zener, 30V, 5%, 5W, 1N5363B	XO-273	R15	Resistor, 200 OHM, 5% 1/4W	XO-143
D21-D24	Diode, 1N5401	XO-263	R16	Resistor, 180 OHM, 5% 1/4W	XO-24
D26	Diode, Zener, 30V, 5%, 5W, 1N5363B	XO-273	R17	Resistor, 100 OHM, 5% 1/4W	XO-28
D31-D34, D36	Diode, 1N4004	XO-254	R18	Resistor, 20 OHM, 5% 1/4W	XO-29
D41, D42, D44	Diode, 1N4004	XO-254	R21, R22	Resistor, 1.8KOHM, 5% 2W	XO-135
F11	Fuse, 6 1/4 AMP SLO-BLO	EL-8	R23	Resistor, 200 OHM, 5% 5W	XO-133
F21	Fuse, 2 AMP SLO-BLO	EL-7	R31, R41	Resistor, 750 OHM, 5% 1W	XO-136
F31, F32	Fuse, 1/4 AMP SLO-BLO	EL-5	SCR11	Silicon Controlled Rectifier	XO-131
F41	Fuse, 1 AMP SLO-BLO	EL-6	U11	Diode, Programmable Zener TL431	XO-272
P1	Connector, 4 PIN	PS-87	U31	Voltage Regulator +12V, LM 340T	XO-473
			U41	Voltage Regulator -12V, LM 320	XO-130
			VR1	Potentiometer, 100 OHM	XO-134

X. WIRING AND SCHEMATIC DIAGR

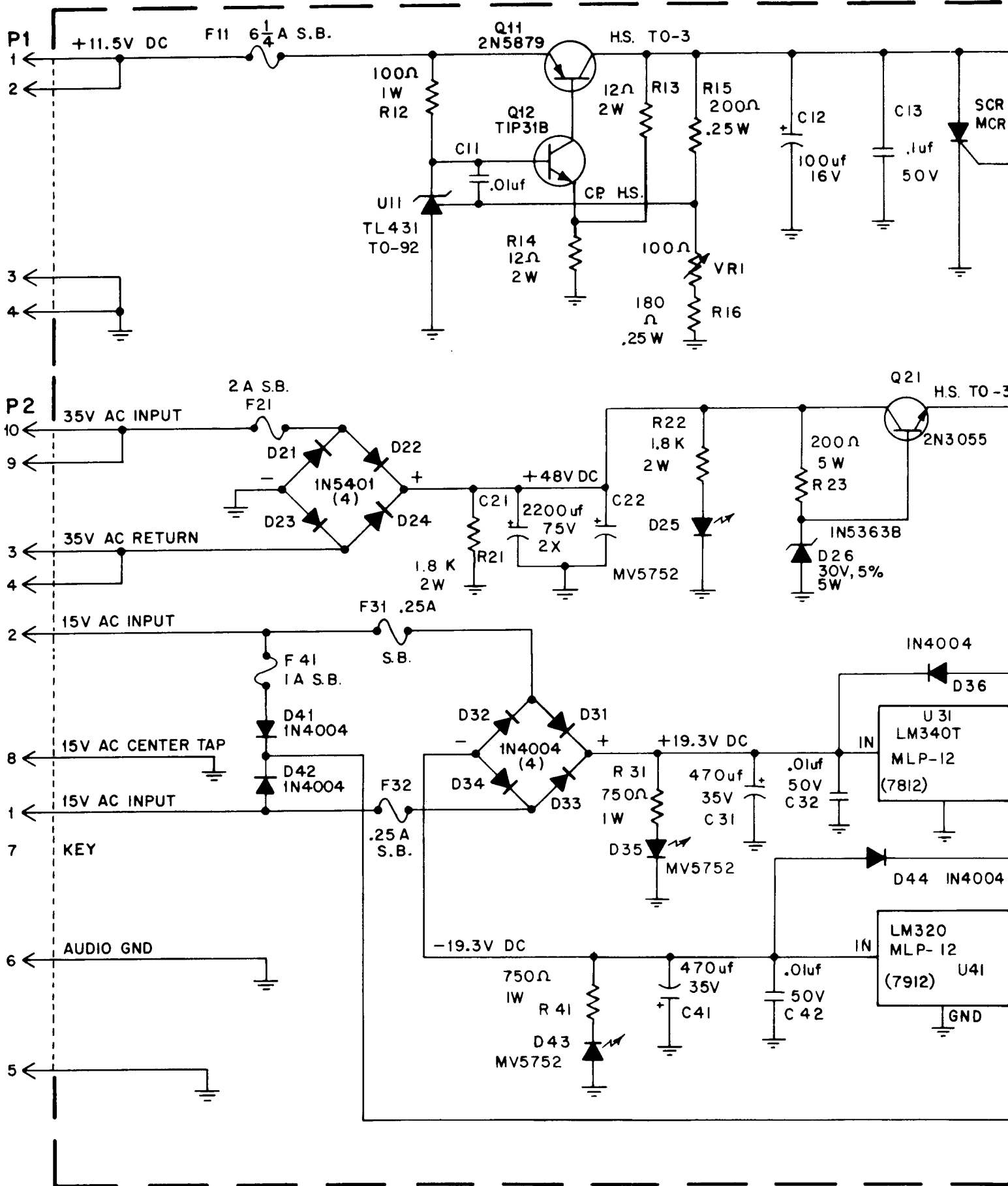

SCHEMATIC DIAGRAMS, PARTS LISTS

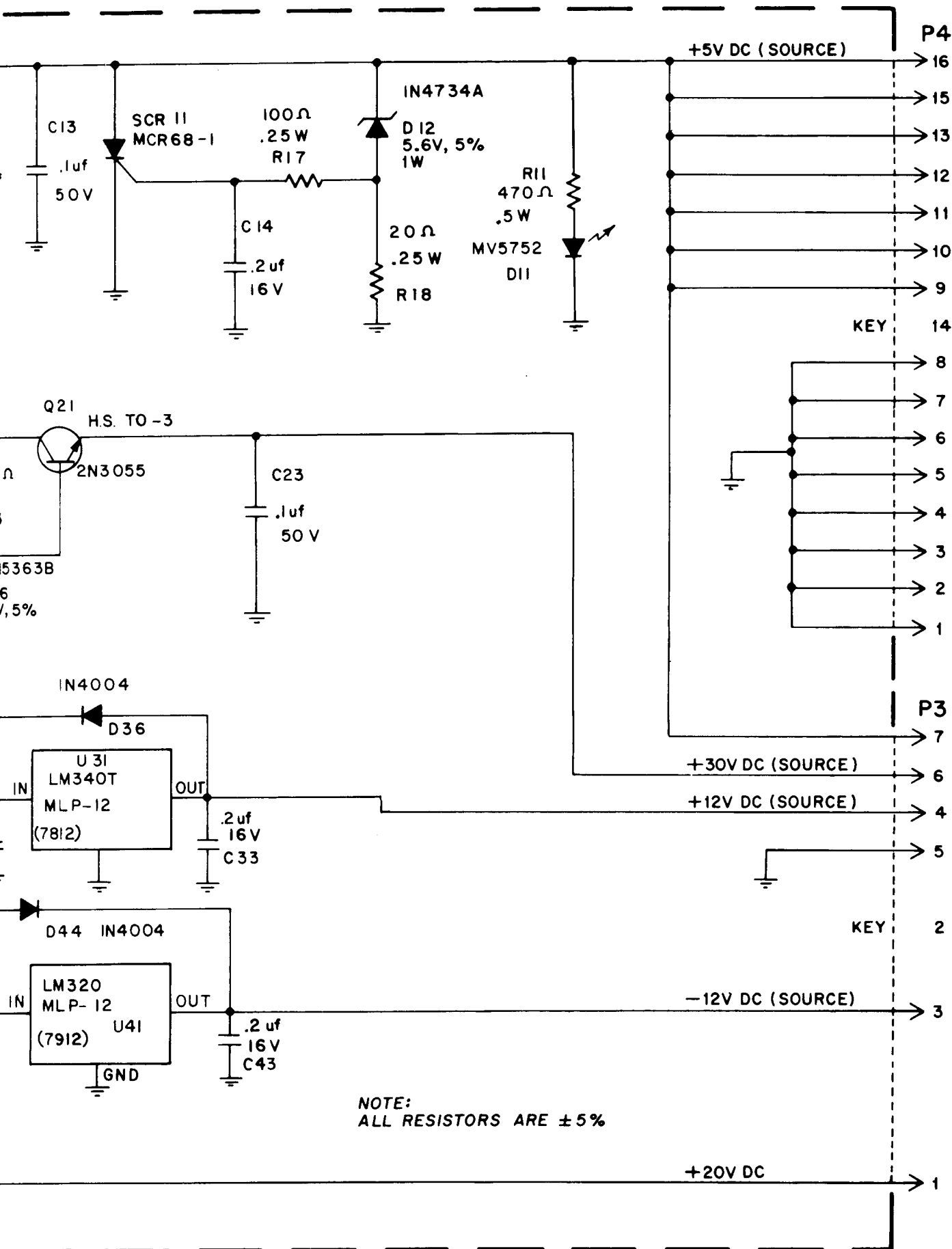

POWER SUPPLY ASSY. (A3), SCHEMATIC DIAGRAM

X. WIRING AND SCHEMATIC DIAGRAMS, PARTS LISTS

SOUND/SPEECH ASSY. (A6), COMPONENT LOCATION

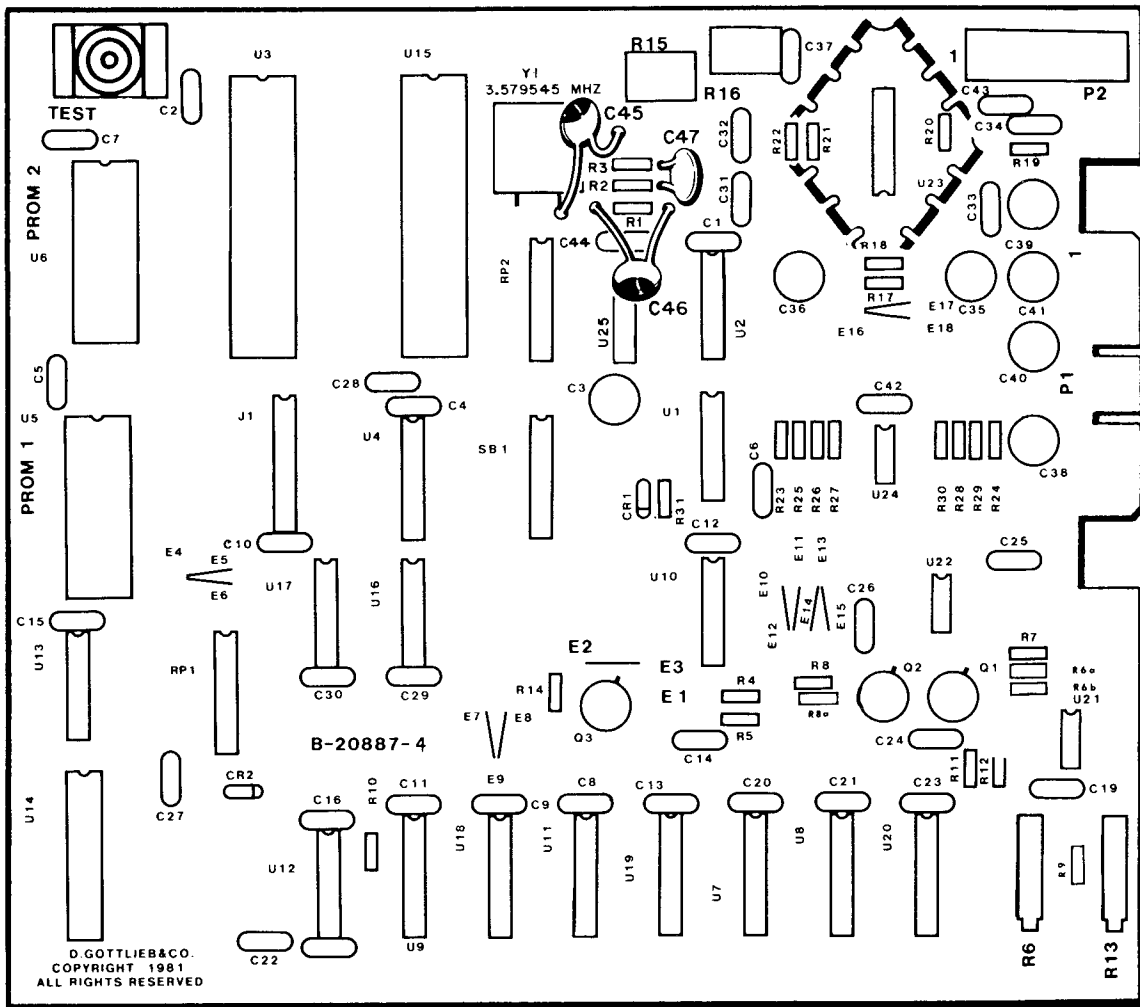

SOUND/SPEECH ASSY. (A6), PARTS LIST

REFERENCE	DESCRIPTION	PART NUMBER	REFERENCE	DESCRIPTION	PART NUMBER
	Sound/Speech Assembly	MA-216	R 15, R 16	Potentiometer, 10K ohm	XO-109
C1, C2	Capacitor, 0.1UF, 25V	XO-248	R 18, R 21	Resistor, 100K ohm, 5%, 1/4W	XO-45
C4, C13			R22	Resistor, 2K ohm, 5%, 1/4W	XO-14
C15, C16, C19			R31	Resistor, 68K ohm, 5%, 1/4W	XO-189
C20, C21, C23			RP1, RP2	Resistor, Dip	XO-168
C25, C26			SB1	Switch, Dip	XO-505
C28-C30, C33			SW1	Switch, Momentary Pushbutton	XO-515
C42, C44			U1	IC, 7414	XO-397
C31-C32	Capacitor, .047UF, 25V	XO-222	U2	IC, SN74LS74N	XO-434
C37	Capacitor, 4.7UF, 35V	XO-291	U3	CPU, R6502-13	XO-360
C3, C38-C41	Capacitor, 47UF, 50V	XO-210	U4	IC, SN74LS138N	XO-437
C14, C24	Capacitor, 100PF	XO-223	U5, U6	EPROM, 2716	PR-53
C22	Capacitor, 300PF	XO-283	U7-U9, U11, U18	IC, SN74LS75	XO-394
C27	Capacitor, 1UF, 50V	XO-217	U10	IC, SN74LS02N	XO-428
C36	Capacitor, 470UF, 35V	XO-284	U12	IC, SN7407N	XO-384
C45, C46	Capacitor, 33PF	XO-277	U13	IC, Inverter, SN74LS05N	XO-411
C47	Capacitor, .01 UF, 100V	XO-202	U14	Voice Chip, SC01	XO468
CR1	Diode, 1N4148	XO-261	U15	RRIOT, R6532-18	XO-361
CR2	Diode, Zener, 1N5225B	XO-269	U16	IC, SN74LS04N	XO-418
Q1, Q3	Transistor, NPN, 2N2222A	XO-320	U17	IC, SN74LS30N	XO-432
Q2	Transistor, PNP, 2N2907A	XO-321	U19, 20	Converter, PMI, 1408A-6P	XO-416
R1, R4, R5	Resistor, 5.6K ohm, 5%, 1/4W	XO-19	U21, U22	IC, LM741CP	XO-393
R11, R12			U23	IC, LM379S	XO-395
R2, R3	Resistor, 2K ohm, 5%, 1/4W	XO-14	U24	IC, Dual Comparitor, LM193	XO-396
R6, R13	Potentiometer, 10K	XO-108	U25	Inverter, 7404	XO-402
R6A, R7, R23-R30	Resistor, 10K ohm, 5%, 1/4W	XO-18	Y1	Crystal, 3.579545MHZ	XO-456
R8, R8A, R14	Resistor, 1K ohm, 5%, 1/4W	XO-5		Socket 22 Pin Dip	XO-467
R6B	Resistor, 1.8K ohm, 5%, 1/4W	XO-37		Socket 24 Pin (2)	XO-529
R9	Resistor, 2.2K ohm, 5%, 1/4W	XO-27		Socket 40 Pin (2)	XO-530
R10	Resistor, 1.5K ohm, 5%, 1/4W	XO-20			

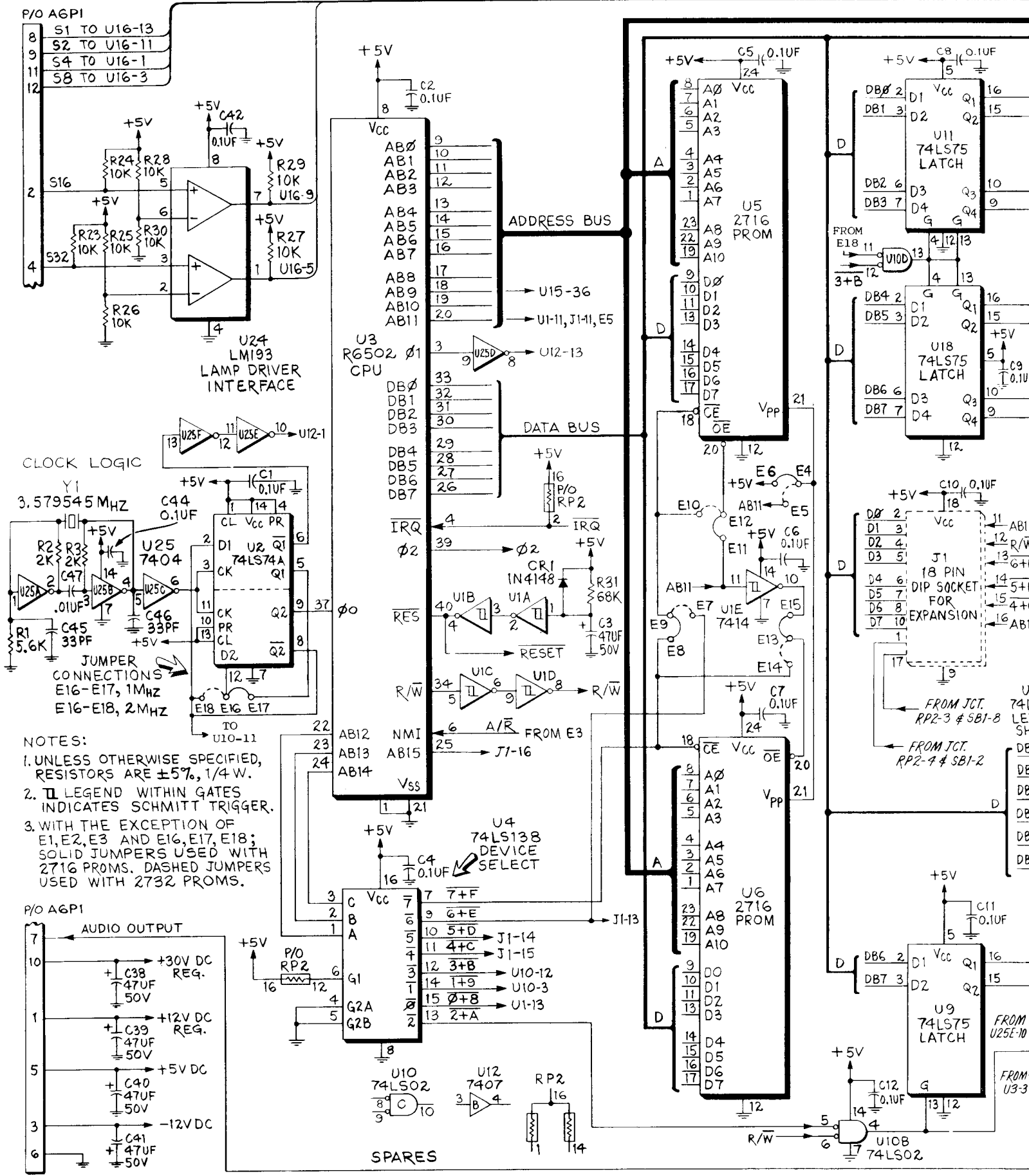

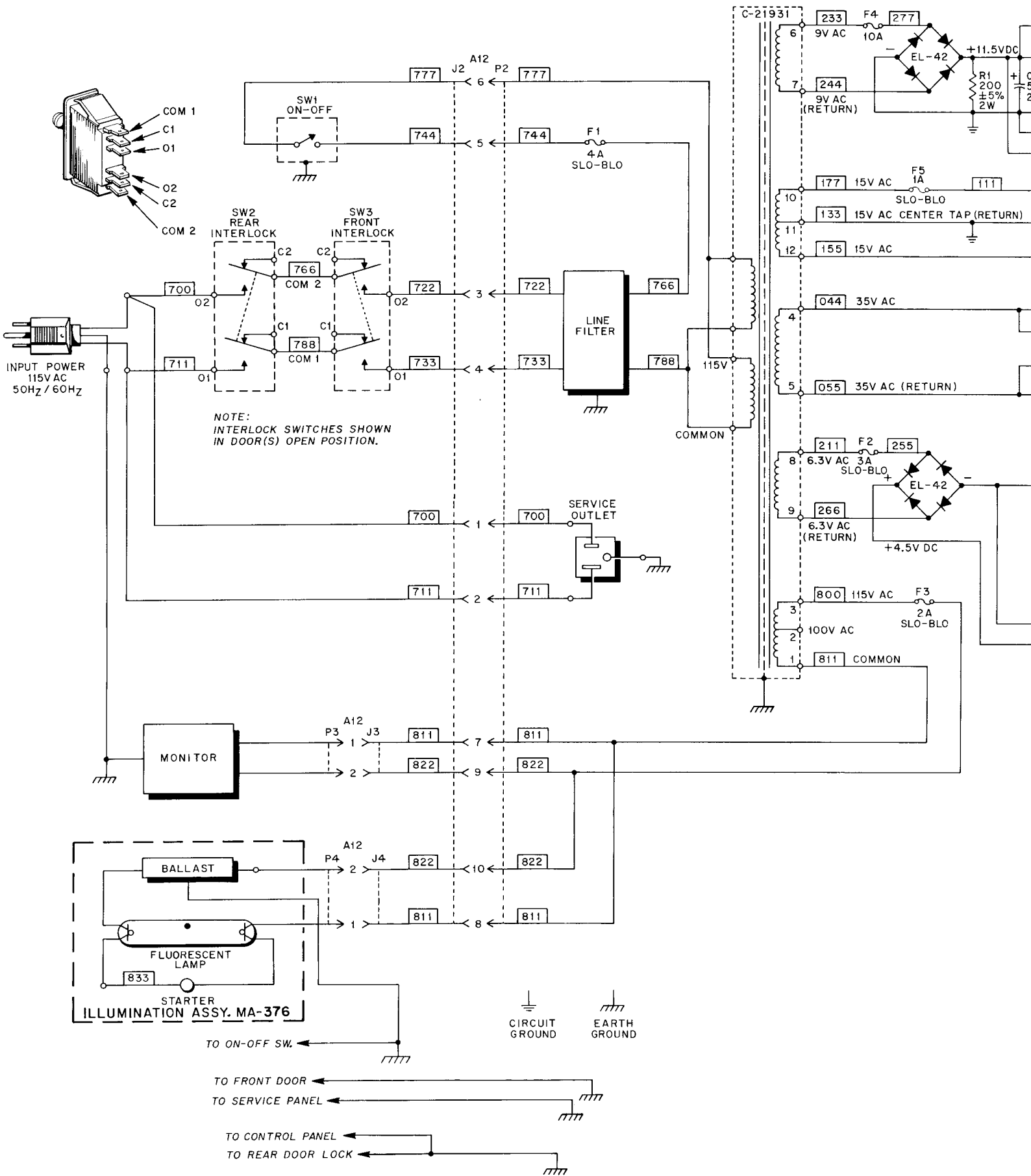

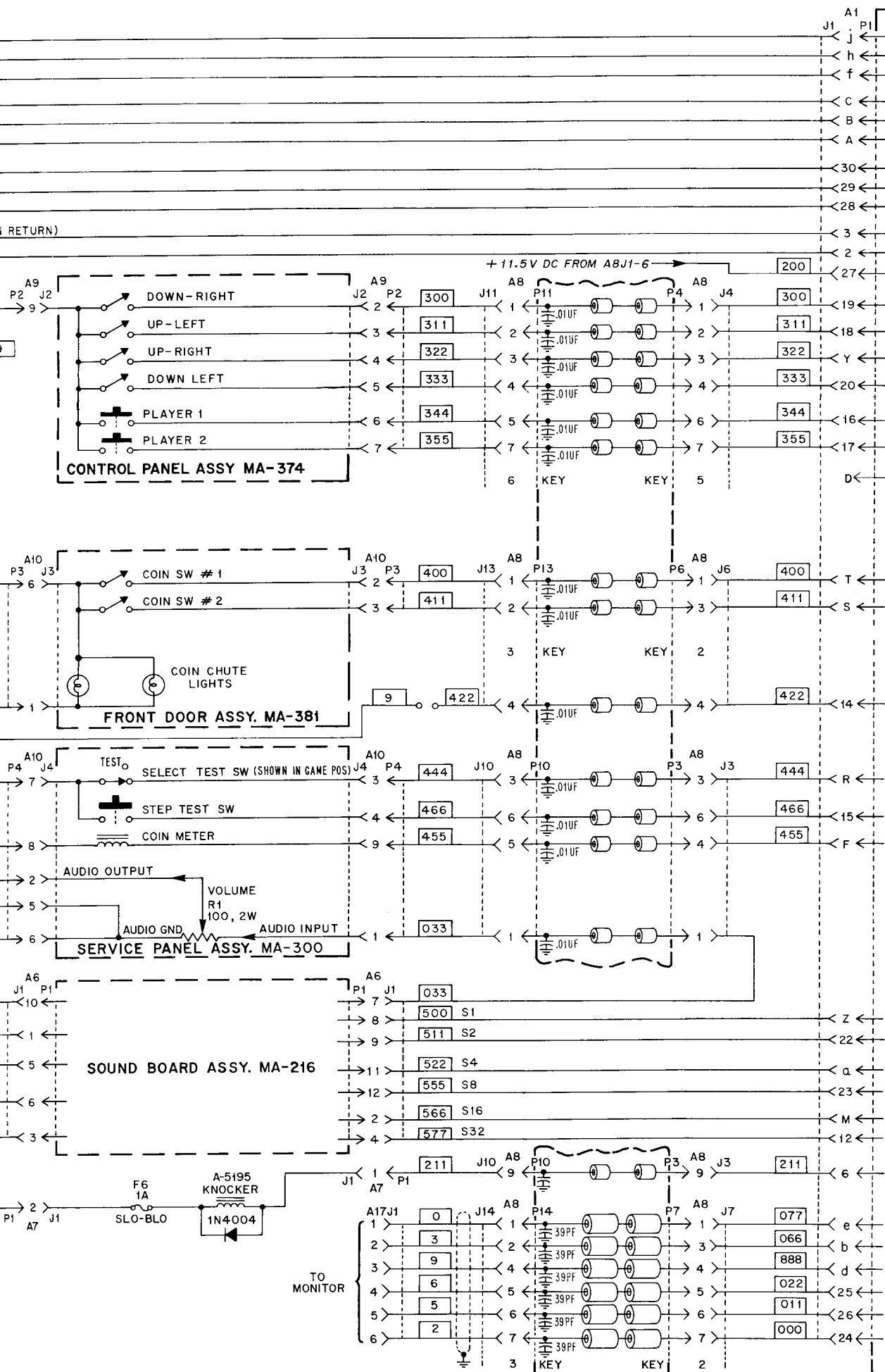

(VIDEO)
 MAIN LOGIC BOARD ASSY.
 MA-378

PRIMARY POWER/FILTER BOARD/INTERCONNECTION DIAGRAM

XI. PARTS INFORMATION

TABLE OF CONTENTS

	PAGE
SPEAKER/MARQUEE ASSY.	34
ILLUMINATION ASSY.	34
CONTROL PANEL ASSY.	35
SERVICE PANEL ASSY.	36
BOTTOM PANEL ASSY.	37
CABINET PARTS	38
CABINET PARTS	39

XI. PARTS INFORMATION

SPEAKER/MARQUEE ASSY. AND ILLUMINATION ASSY.

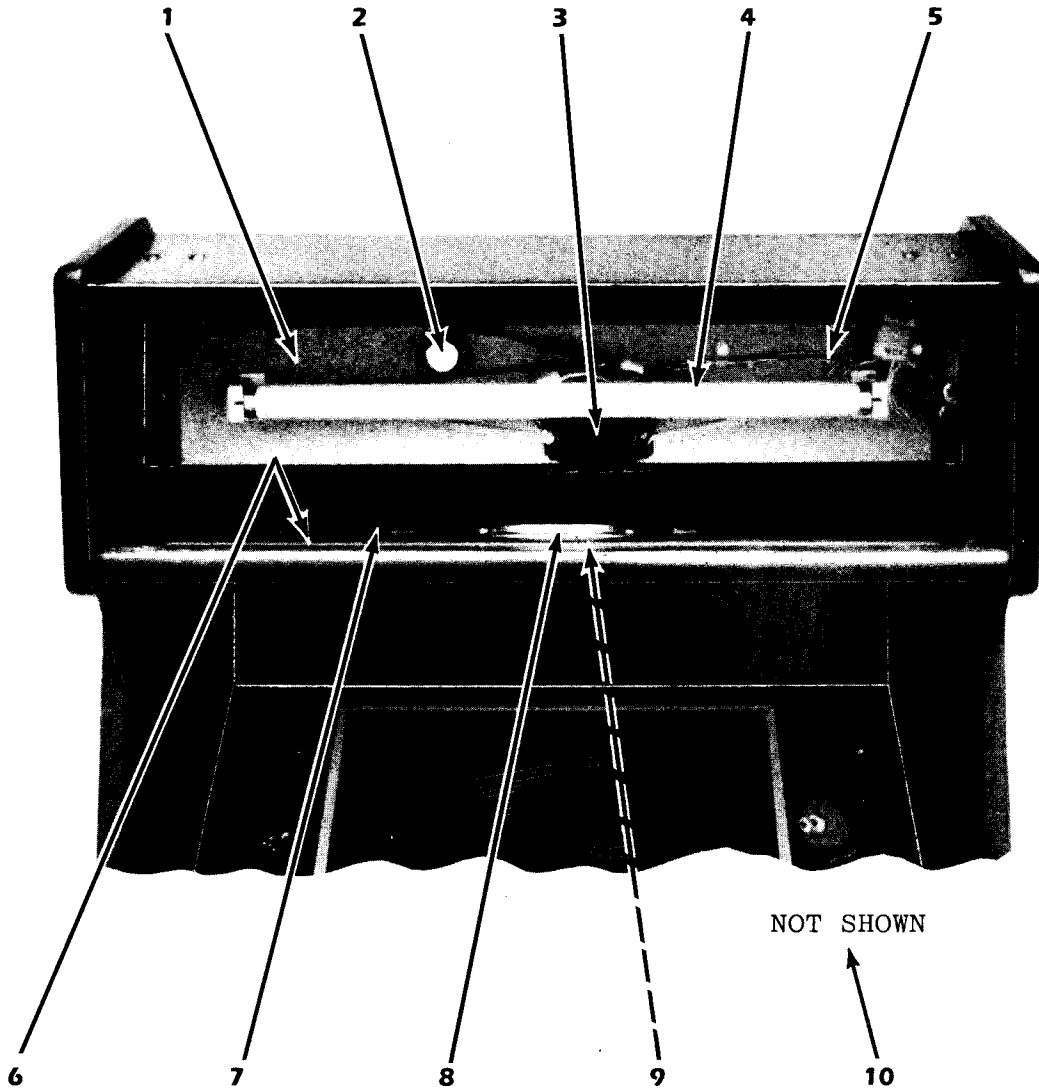

ITEM	DESCRIPTION	PART NO.
1.	Illumination Assy.	MA-376
2.	Starter	EL-69
3.	Ballast (60 HZ)	EL-70
4.	Lamp, Fluorescent	LA-4
5.	Cable Assy.	MA-364
6.	Speaker Assy.	MA-377
7.	Cable Assy.	MA-318
8.	Speaker	EL-83
9.	Speaker Grill	B-20931
10.	Marquee, Lexan (Screen)	DE-3

XI. PARTS INFORMATION

CONTROL PANEL ASSY.

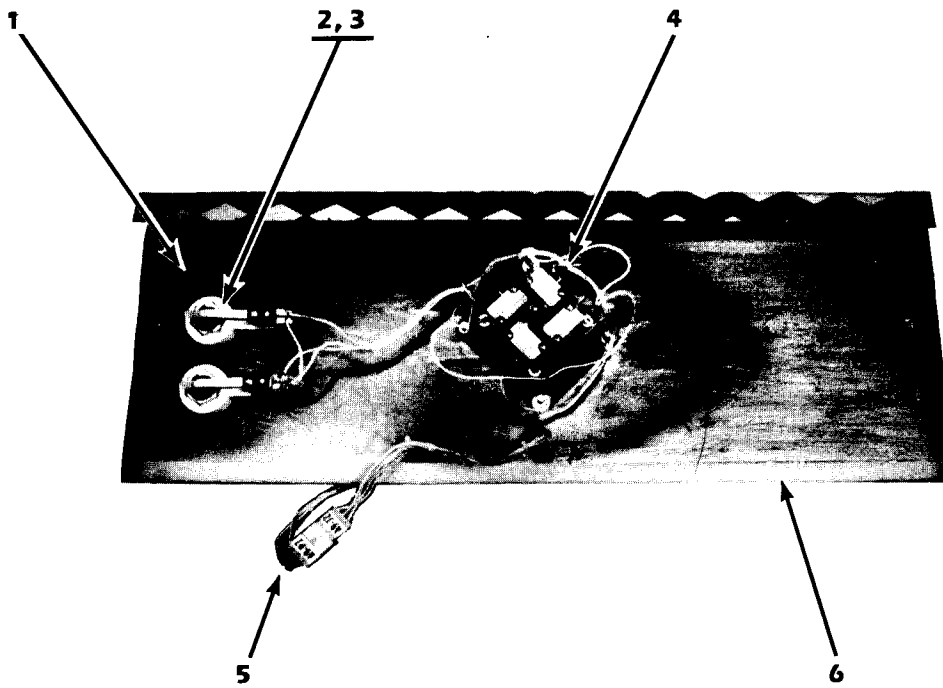

ITEM	DESCRIPTION	PART NO.
1.	Control Panel Assy.	MA-374
2.	Short Button (2)	A-21970
3.	Button Holder and Switch (2)	A-21971
4.	Joystick	C-22458
5.	Cable Assy.	MA-382
6.	Lexan Overlay	DE-1

XI. PARTS INFORMATION

SERVICE PANEL ASSY.

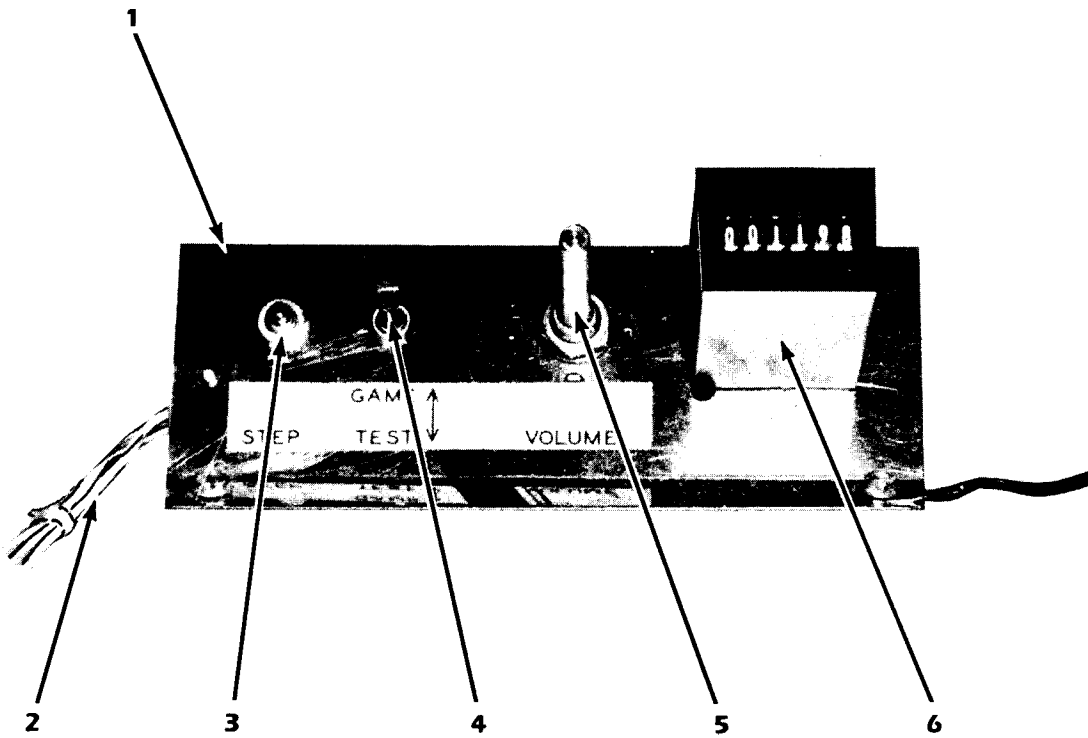

ITEM	DESCRIPTION	PART NO.
1.	Service Panel Assy.	MA-300
2.	Cable Assy.	MA-316
3.	Switch (Push Button)	EL-57
4.	Switch (Toggle)	EL-85
5.	Volume Control	XO-104
6.	Coin Meter	EL-84

XI. PARTS INFORMATION

BOTTOM PANEL ASSY.

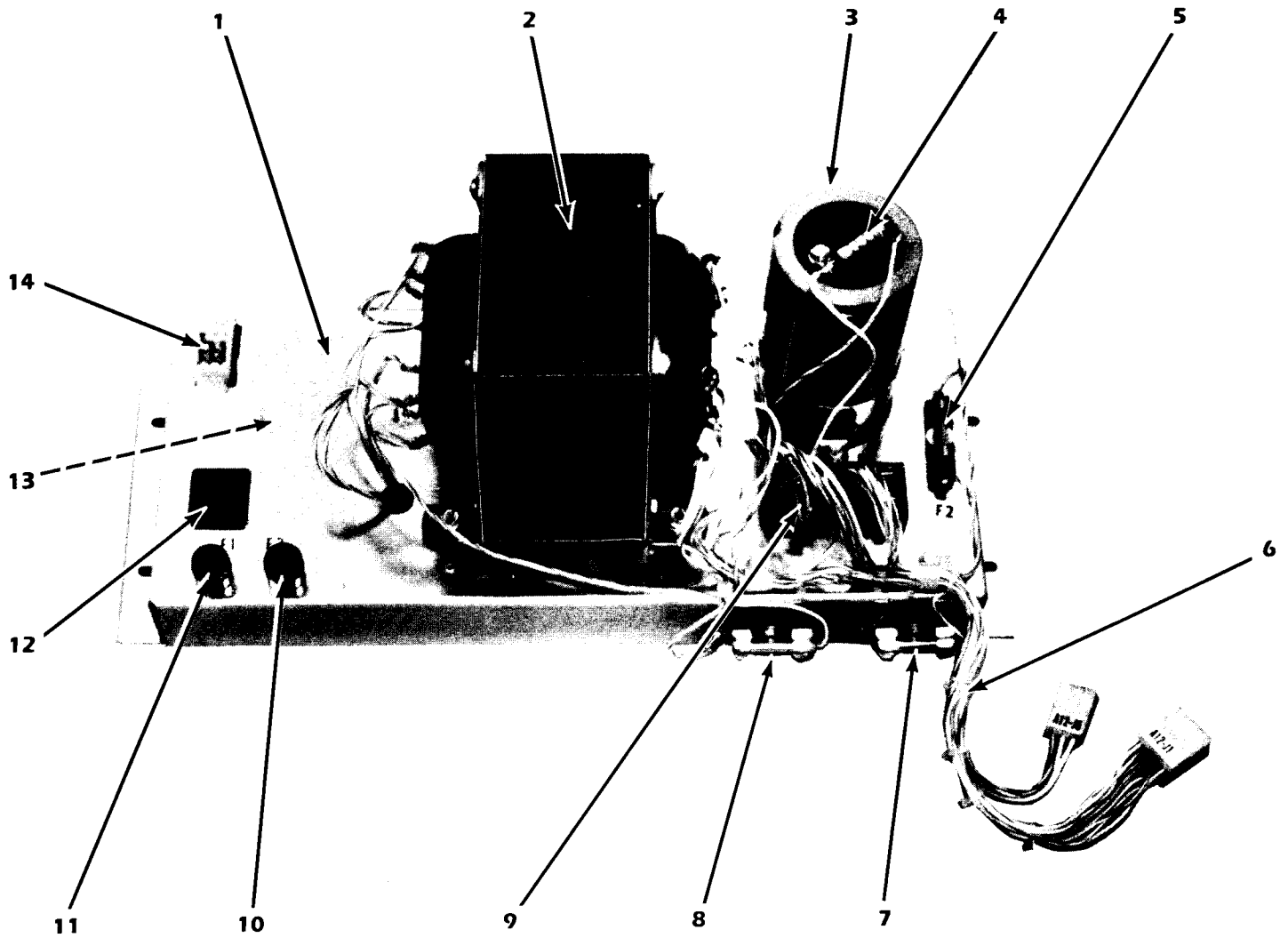

ITEM	DESCRIPTION	PART NO.
1.	Bottom Panel Assy.	MA-375
2.	Transformer	C-21931
3.	Capacitor, 50, 000UF, 25V	XO-141
4.	Resistor, 200 OHM, 5%, 2W	XO-142
5.	Fuse, 3 AMP, SLO-BLO	EL-9
6.	Cable Assy. (Secondary)	MA-314
7.	Fuse, 1 AMP, SLO-BLO	EL-6
8.	Fuse, 10 AMP	EL-23
9.	Bridge Rectifier (2)	EL-42
10.	Fuse, 2 AMP, SLO-BLO	EL-7
11.	Fuse, 4 AMP, SLO-BLO	EL-33
12.	Service Outlet	A-18133
13.	Line Filter	EL-50
14.	Cable Assy. (Primary)	MA-363

XI. PARTS INFORMATION

CABINET PARTS

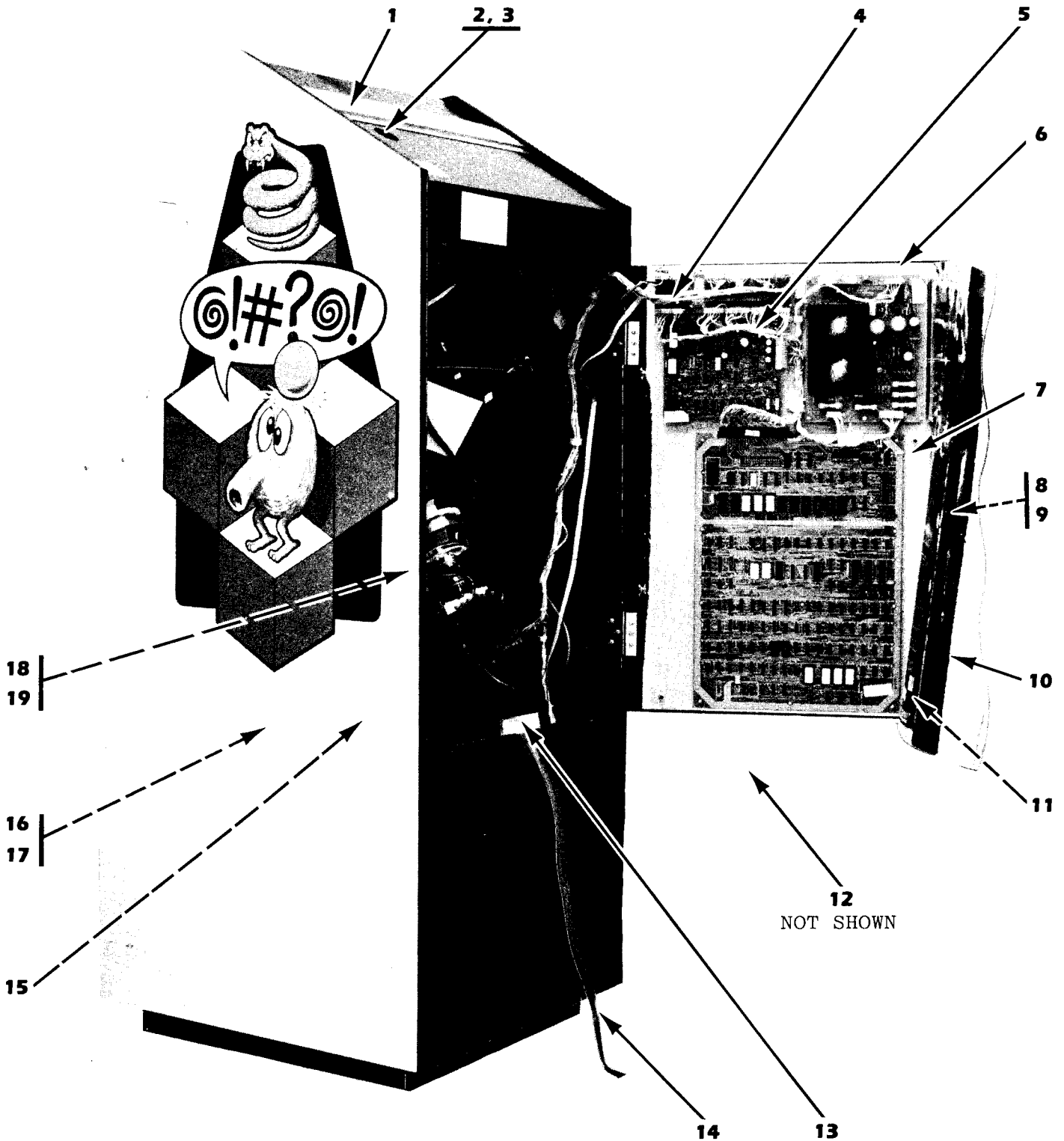

ITEM	DESCRIPTION	PART NO.
1.	Vent Channel (1)	D-21754
2.	On-Off Switch	EL-56
3.	Switch Plate	A-22396
4.	Cable Assy. Master Electronics	MA-397
5.	Interconnect Cable	MA-398
6.	Back Door	D-21896
7.	Master Electronic Board	MA-394
8.	Rear Door Lock	MH-0
9.	Anchor Plate, Lock	MH-1
10.	Shield, Top	C-22632

ITEM	DESCRIPTION	PART NO.
11.	Shield, Bottom	C-22633
12.	Clip Bracket, Shield	B-22631
13.	Line Cord	B-15357
14.	Cover Plate, Line Cord	A-21955
15.	Cable Assy. High Voltage	MA-360
16.	Knocker Assy.	MA-384
17.	Fuse, 1 AMP, SLO-BLO	EL-6
18.	Interlock Switch	EL-66
19.	Cover, Interlock Switch	A-21888

XI. PARTS INFORMATION

CABINET PARTS

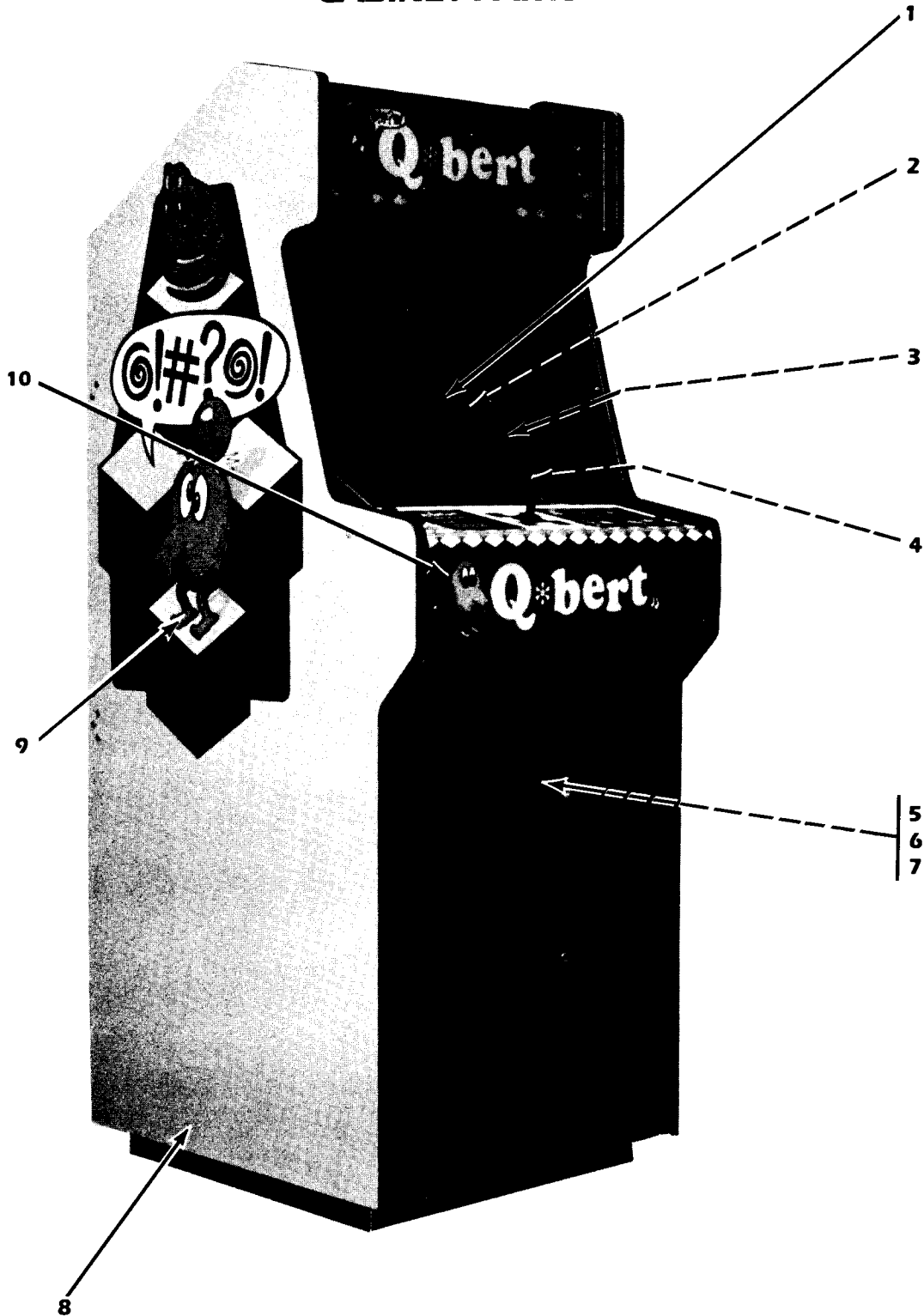

ITEM	DESCRIPTION	PART NO.	ITEM	DESCRIPTION	PART NO.
1.	Top Glass (Screened)	SG-1	7.	Cover, Interlock Switch	A-21888
2.	Monitor Filter Glass	D-22465	8.	3" Leg Adjuster (2)	MH-21
3.	Monitor Mask	D-22463	9.	Decal (Right)	DE-4
4.	Monitor	C-22462		Decal (Left)	DE-4
5.	Cable Assy., Front Door	MA-365	10.	Lexan Overlay (Screen)	DE-2
6.	Interlock Switch	EL-66			

SERVICE NOTES

LIMITED WARRANTY

D. Gottlieb & Co. warrants to the initial purchaser of the D. Gottlieb & Co. machine that the items listed in the following schedule as installed and used in the original D. Gottlieb & Co. machine will for the applicable period set forth in the schedule, computed from the initial date of purchase from an authorized D. Gottlieb & Co. distributor, be free of defects in materials and workmanship:

SCHEDULE

GAME	ITEM	WARRANTY PERIOD
Pinball	All Electronic	90 days
	Printed circuit boards	
Pinball-Video	All Electronic	90 days
	Printed Circuit Boards	
	Card Cage	90 days
	Television Monitor	30 days
Video	All Electronic	90 days
	Printed Circuit Boards	
	Television Monitor	30 days

This Limited Warranty does not apply to any parts damaged in the course of handling or assembling by the customer or damage due to other than normal use or use in violation of instructions or reasonable practices, or further damaged in return shipment. This Limited Warranty is made only to the original customer, and is and shall be in lieu of all other warranties expressed or implied, and of all other obligations or liabilities on the part of D. Gottlieb & Co. and in no event shall D. Gottlieb & Co. be liable for any anticipated profits, consequential damages, loss of time, or other losses incurred by the customer in connection with the purchase or operation of D. Gottlieb & Co. machines or components thereof.

The registration card with each D. Gottlieb & Co. factory-wired machine must be filled in and returned to D. Gottlieb & Co. within ten days after date of purchase for this Limited Warranty to be effective. This Limited Warranty applies only to machines so registered.

THIS LIMITED WARRANTY IS IN LIEU OF ANY OTHER EXPRESS OR IMPLIED WARRANTIES, INCLUDING ANY IMPLIED WARRANTY OF MERCHANTABILITY OR FITNESS, AND OF ANY OTHER OBLIGATION ON THE PART OF THE SELLER AND D. GOTTLIEB & CO.

 **Gottlieb**
AMUSEMENT GAMES

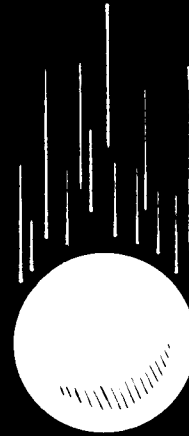
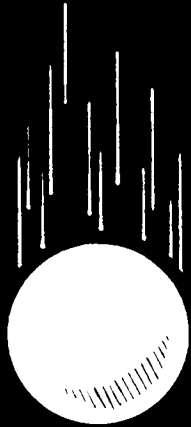
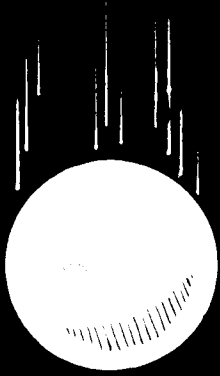

Gottlieb AMUSEMENT GAMES

165 W. Lake Street Northlake, IL 60164
(312) 562-7400 Telex 72-8463

A Columbia Pictures Industries Company

