

P U C K M A N  
DIL SWITCH SETTINGS

SW	ON	OFF
1	1 coin, 1 credit	2 coin, 1 credit
2	1 coin, 3 credit	1 coin, 5 credit
3	Bonus 20k	Bonus 15k
4	Hard Game	Easy Game
5	5 Puck	3 Puck
6	Table Game	Upright Game

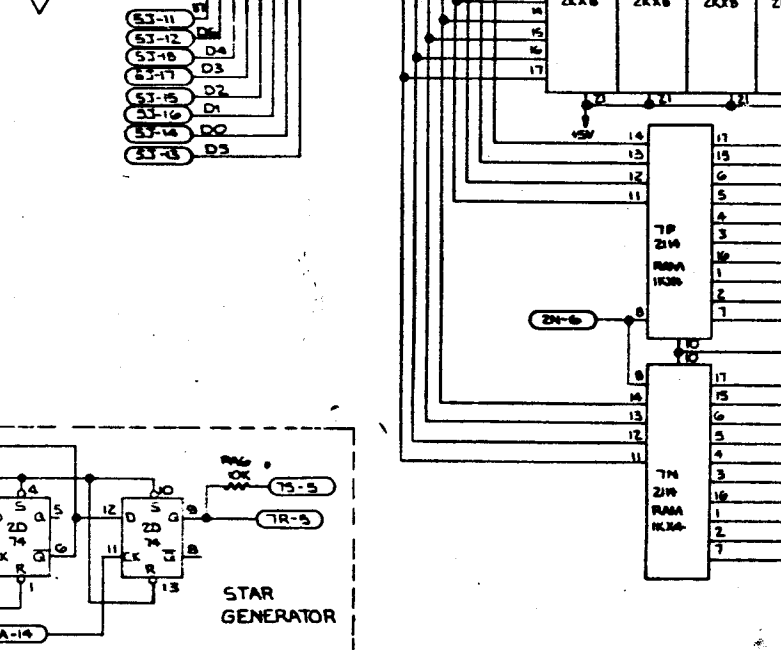

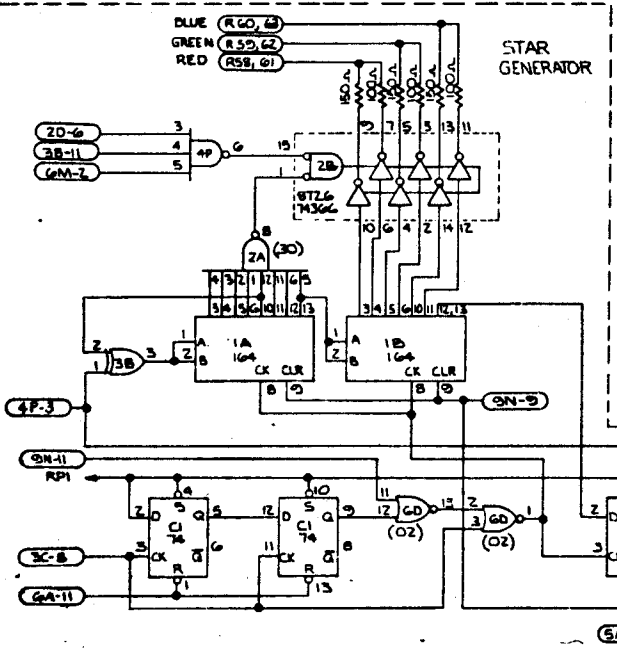
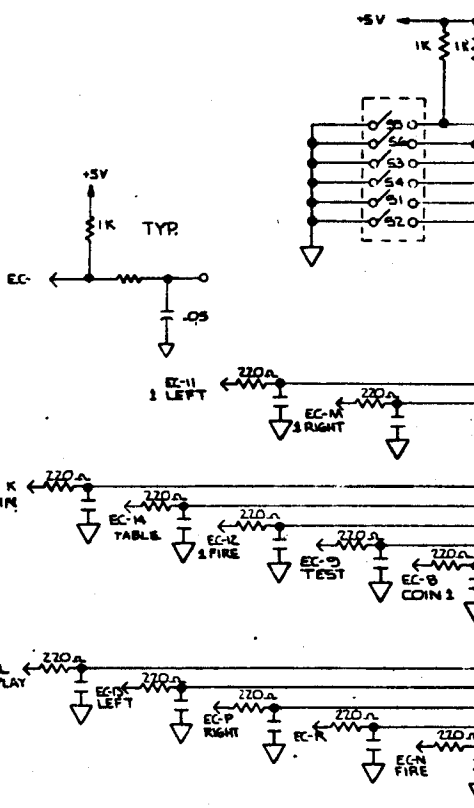
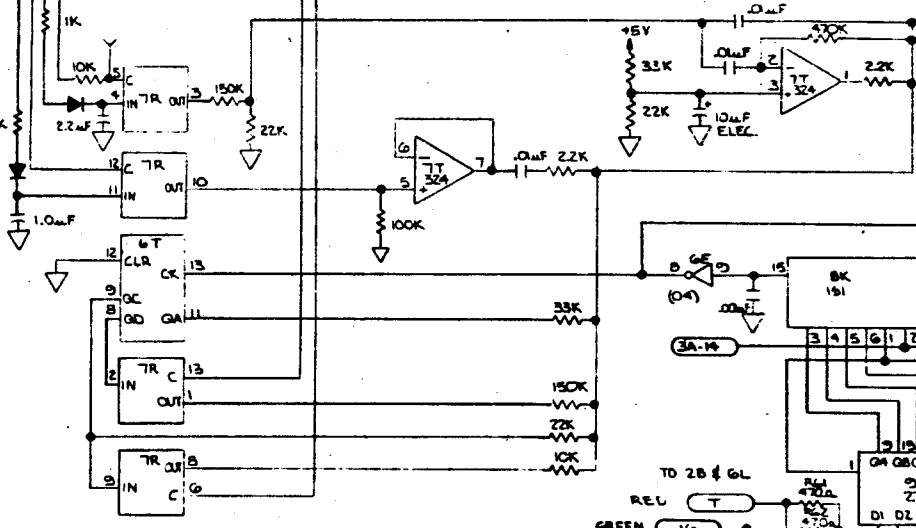
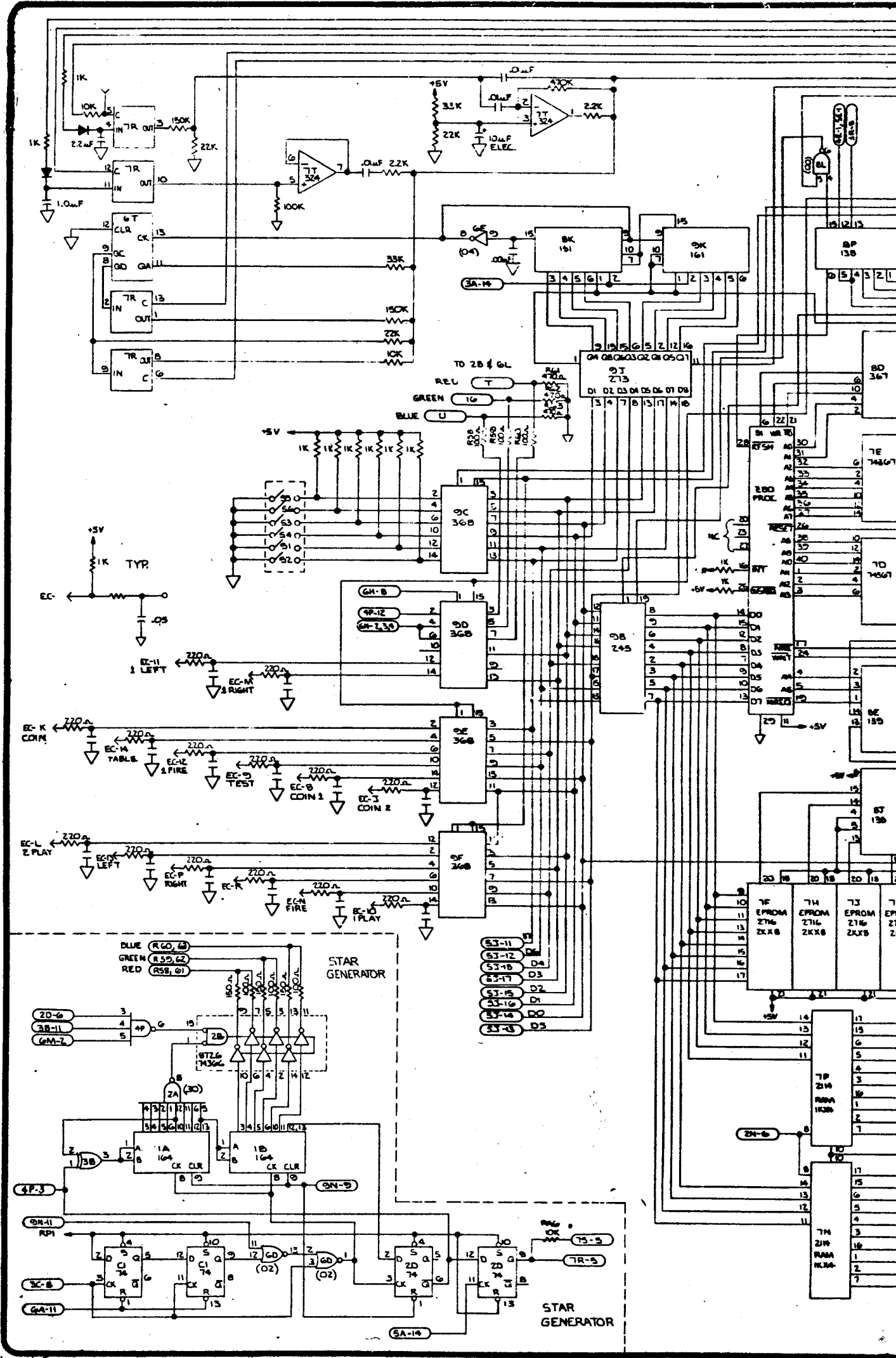
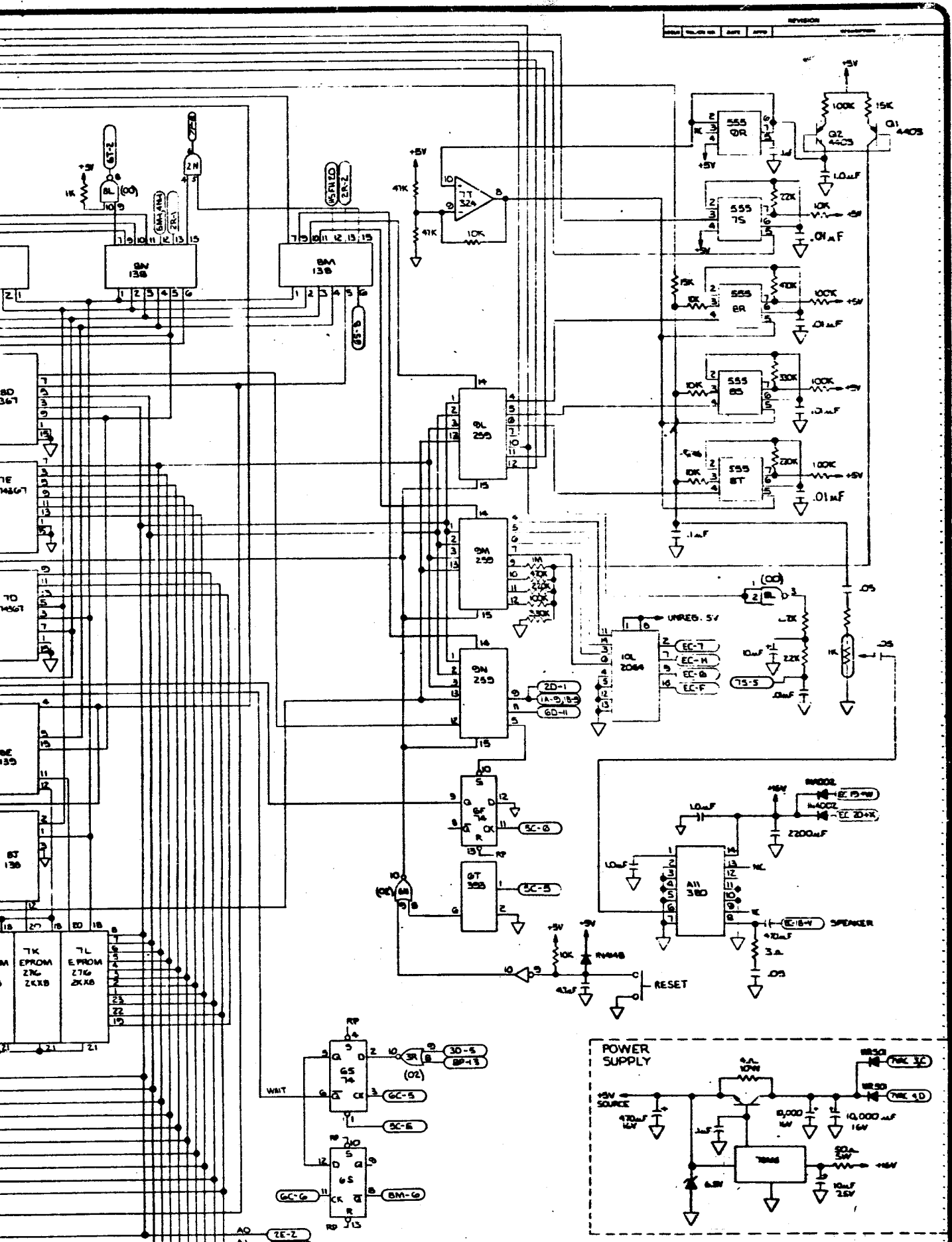

REV	DATE	BY	APP

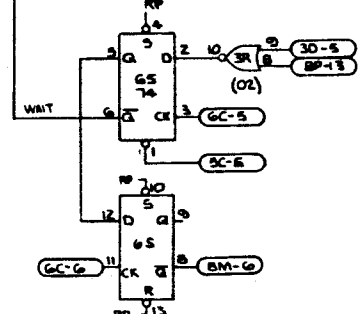
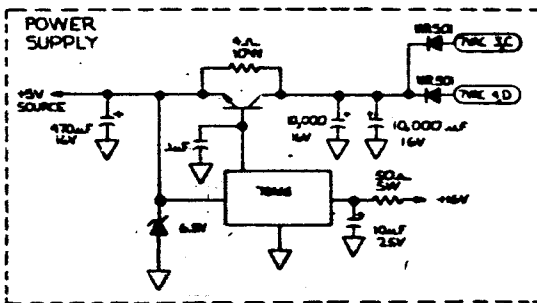
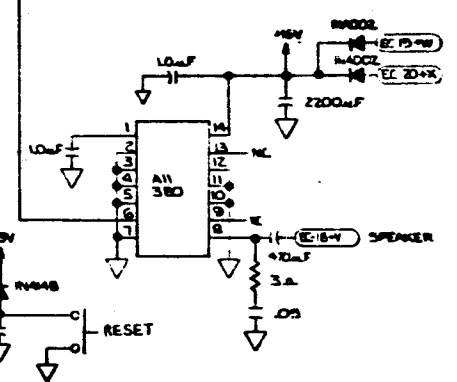

- A0 7E-2
- A1 3E-5
- A2 7E-11
- A3 3E-14
- A4 3E-2
- A5 7E-14
- A6 7E-2
- A7 2F-5
- AB 2F-14
- A9 2F-11

UNLESS OTHERWISE SPECIFIED DIMENSIONS IN INCHES METRIC DIMENSIONS IN PARENTHESES REMOVE ALL BURRS AND SHARP EDGES TOLERANCES: 1 PLACE DEC = ± 2 PLACE DEC = ± 3 PLACE DEC = ± HOLE ± ANGLES ± SCALE: DO NOT SCALE DRAWING	TITLE BLOCK PROJECT: 1005 DATE: 2-25-88 DRAWN BY: [Signature] CHECKED BY: [Signature] APPROVED BY: [Signature]	G.W. 1005
--	---	-----------

SYNC GENERATOR

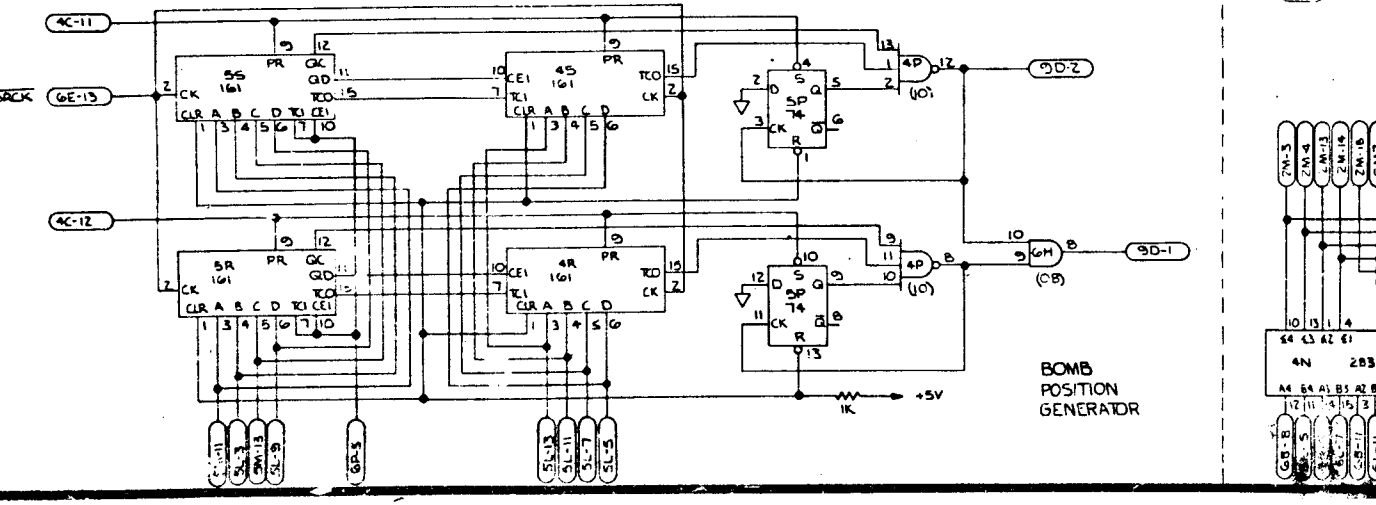
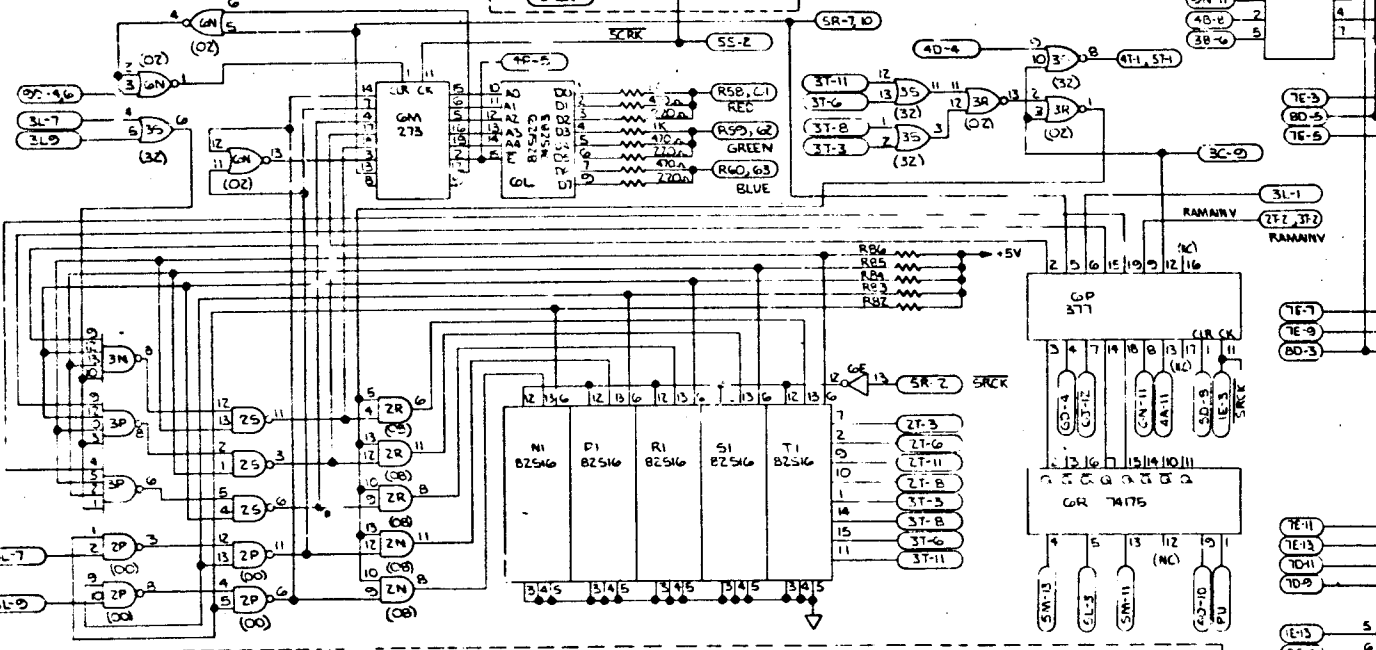
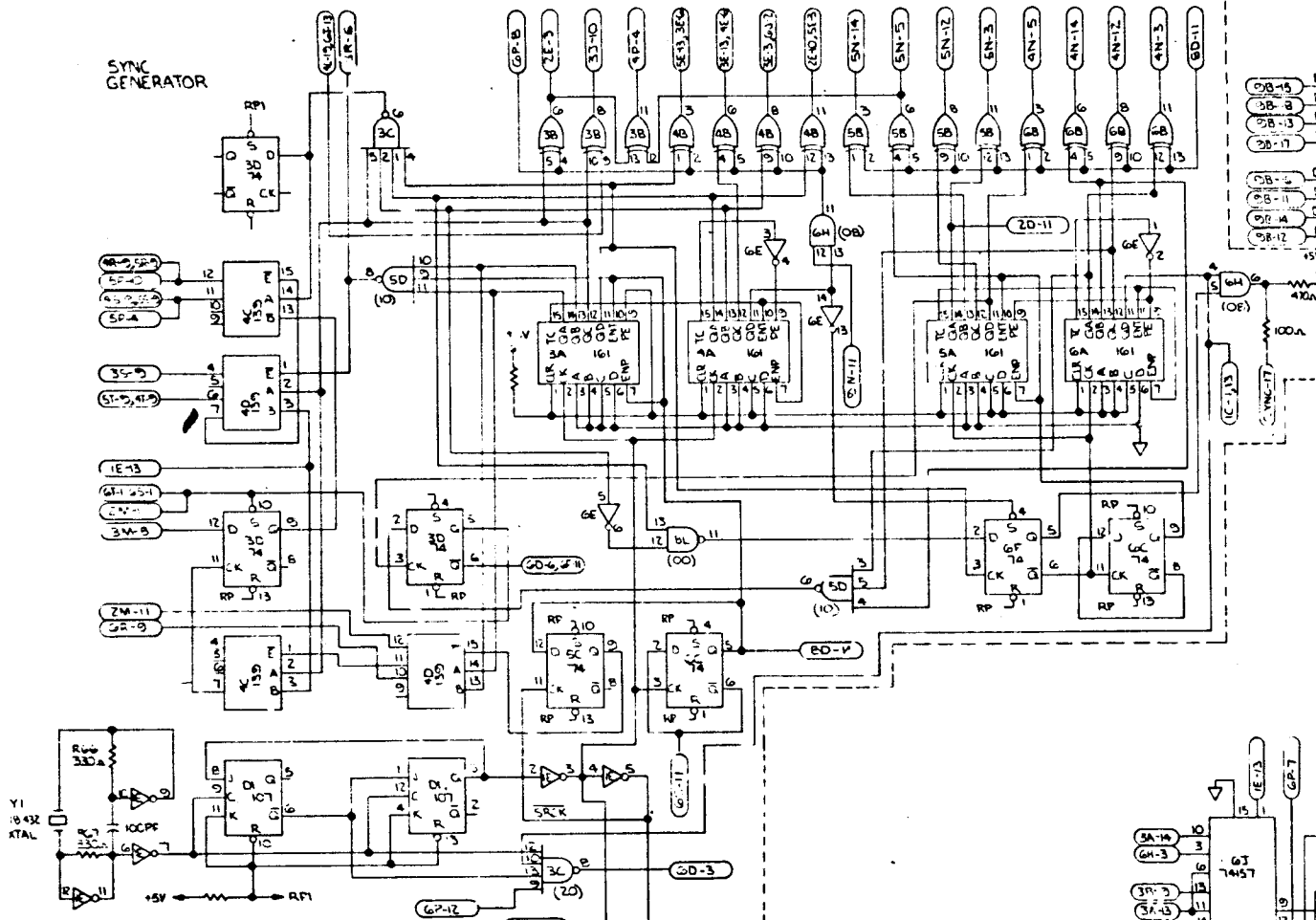

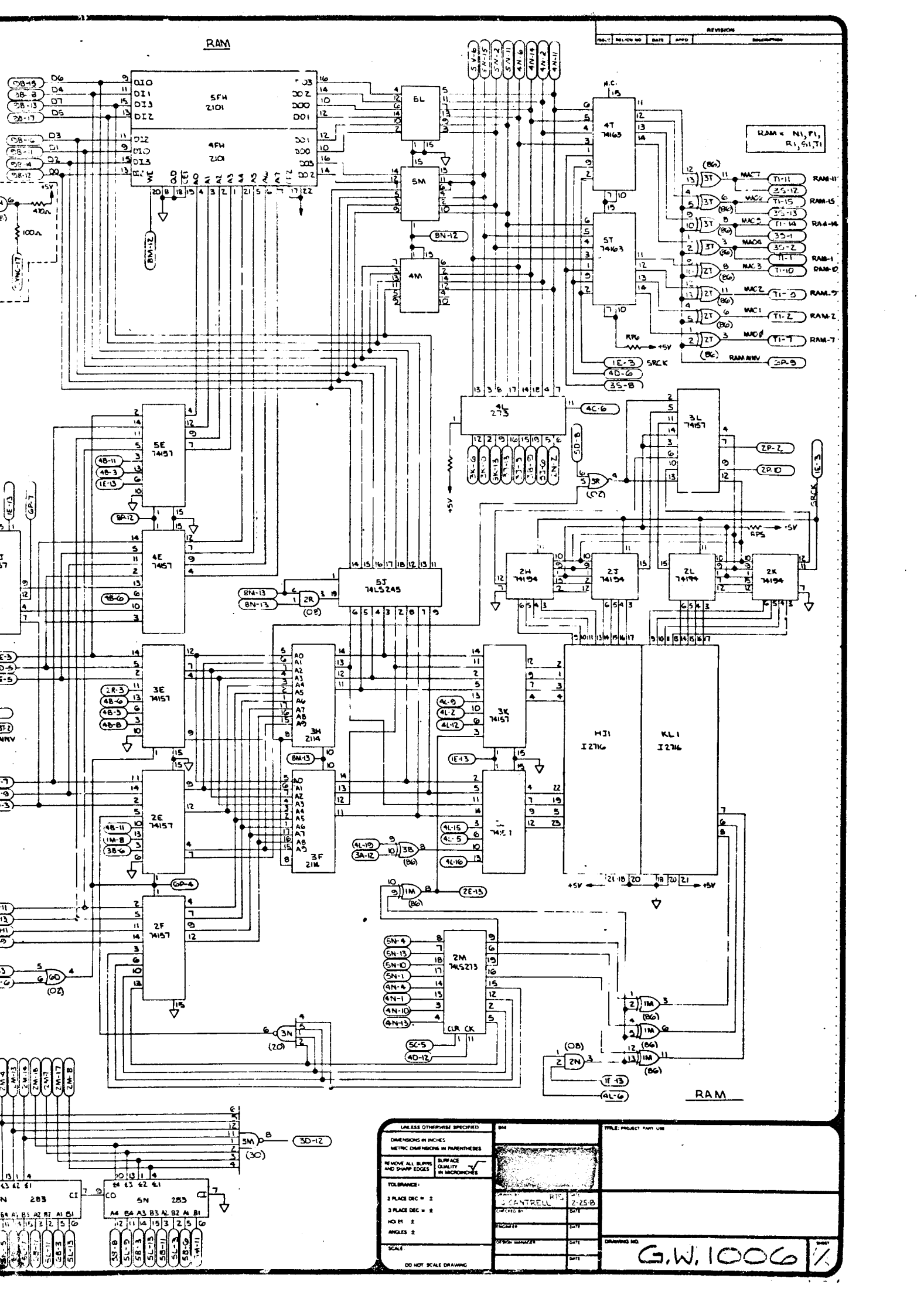

RAM

REV.	DATE	APPROV.	DESCRIPTION

RAM = N1, P1, R1, G1, T1

RAM

UNLESS OTHERWISE SPECIFIED		TITLE: PROJECT PART LOW	
DIMENSIONS IN INCHES METRIC DIMENSIONS IN PARENTHESES		SURFACE QUALITY REMOVE ALL BURRS AND SHARP EDGES	
TOLERANCE: 2 PLACE DEC = ± 3 PLACE DEC = ±		CHECKED BY: J. CANTRELL DATE: 7-25-68	
NO. OF: 2 ANGLES: 2		DRAWING NO. G.W. 1006	
SCALE: DO NOT SCALE DRAWING		DATE:	